

UNIV OF
TORONTO
LIBRARY

1115

Section L_3
no 688



P
Mech. Dep.
M. M. Dep.

Tech Collier Engineer
" " " "

Mines *and* Minerals

VOLUME XXXII

August, 1911, to July, 1912

124889
11/11/12

SCRANTON, PA.
INTERNATIONAL TEXTBOOK CO.
1912

COPYRIGHT, 1912, BY INTERNATIONAL TEXTBOOK CO.
ALL RIGHTS RESERVED

Digitized by the Internet Archive
in 2008 with funding from
Microsoft Corporation

<http://www.archive.org/details/collieryengineer32londuoft>

INDEX

INDEX A—Authors, Subjects, and Titles of Articles

(Separate Indexes of "Book Reviews," "Personals and Obituaries," "Catalogs Received," and "Trade Notices" follow "Index A")

	Page		Page		Page
A CCIDENTS, APPLIANCES FOR PRE-VENTING	74	Antiseptic Treatment of Mine Timbers.....	706	Bettel, William, Colorimetric Estimation of Gold	126
Accidents, Chinese Laws Concerning Mine..	618	Antitrust Laws and the Coal Industry.....	644	Big Blast at Steins, N. Mex.....	539
Accidents During Second Ten Days of Month	535	Apparatus for Detecting Marsh Gas.....	702	Binder, O., Mechanical Sampling of Ores....	735
Accidents in Ohio, 1911.....	400	Appliances for Preventing Accidents.....	74	Bismuth Alloy.....	745
Accidents, To Decrease Anthracite Mine....	636	Appointment of H. M. Inspectors.....	220	Bituminous Coal Output in United States, 1911	400
Account, Profit, and Loss.....	83	Appointment of Ohio Mine Inspectors.....	18	Bituminous Coal Seam, Working Vertical....	703
Accumulations of Gas, Relieving.....	409	Appropriations for Bureau of Mines, Recommended	455	Bituminous Mining Law of Pennsylvania, 1911	527, 646
Advance in Air Compression (Rogler-Hoerbiger Valve).....	339	Aqueduct, Bonus System on Los Angeles....	679	Black Oak Mine, California.....	41
Affelder, Wm. L., Air-Compressor Explosion	651	Arbitration in the Southwest.....	221	Blackwell Colliery, Coal Dust and Zone Systems	23
Africa, Gold Dredging.....	60	Arenberg Mine, Shaft Bottom at.....	413	Blair, J. I., Settling Chamber for Smelter Fume	125
Agitation of Slime Pulp, Air-Lift.....	239	Argall, Philip Henry, Milling at Stratton's Independence	319	Blakeley, A. G., Calorific Value of Anthracite	72
Agitator, Parral Tank as a Slime.....	305	Arkansas, Coal Mining in.....9, 66,	205	Blast at Steins, N. Mex., Big.....	539
Air Compression, Advance in (Rogler-Hoerbiger Valve).....	339	Arkansas, Miners in.....	80	Blast-Furnace Smelting with Oil.....	249
Air Compressor, Care of.....	595	Asbestos in Russia.....	618	Blast Roasting of Galena.....	607
Air-Compressor Explosion.....	651	Asbestos Insulation.....	628	Blast, Sixteen Tons of High Explosive in a Block Caving and Substopping.....	437
Air-Compressor Lubrication.....	664	Ashes at Mine Boiler Plants, Disposal of... 93	648	Blumenstein, W. H., Kanite Explosives.....	674
Air Humidifier, An Effective.....	531	Ashes for Mine Roads, Boiler.....	648	Boddington, H. D., Mineral District of Rayon	605
Air, Humidifying Mine.....	535	Ashley, George H., Bauxite Mining in Tennessee, 419—Coker Creek Gold Field.....	547	Boiler Ashes for Mine Roads.....	648
Air-Lift Agitation of Slime Pulp.....	239	Ashworth, James, Coal Dust, 218—Coal-Dust Explosions, 159—Humidifying Mine Air... 391	659	Boiler Coal Elevator, Navajo Mine.....	640
Alabama, Coal Washing at Lahausage.....	391	Assayers, Pulverizer for.....	560	Boiler House, A Standard.....	255
Alaska, Decision on the Cunningham Claims Alaskan Gold.....	40	Assay, Iodide Method of Copper.....	684	Boiler Plants, Disposal of Ashes at Mine.. 93	583
Alkalinity in Lime, Estimating.....	368	Assay of Gold Solution, Electrolytic.....	496	Boiler Water.....	583
Allard, A. F., Universal Mine Plant and Shafts	131	Assessment Work, Enforced Annual.....	624	Bolus, G. H., Overhead Electrical Practice in Mines	284
Alloys, Brass and Bronze.....	670	Asphalt, Pitch Lake, Trinidad.....	300	Bonus System on Los Angeles Aqueduct.... 679	276
Allowable Error in Closing Survey.....	401	Atlantic City Mining District, Wyoming... 472	300	Bordeu—Roumania's Newest Oil Field.....	276
Alquife Plant, Spanish Iron-Ore Treatment Plant	237	Atmospheres That Extinguish Flames.....	650	Bore Holes for Relieving Accumulations of Gas	409
Aluminum and Bauxite Production.....	503	Auric-Hydroxide	687	Borneo, Petroleum in.....	95
Amalgamation, Chilian Mills and.....	108	Australia, Irrigation With Artesian Waters.. 266	374	Boss Amalgamation Process.....	667
Amalgamation Process, Boss.....	667	Australia, New Firedamp Detector.....	266	Bottom Creek Mine Explosion.....	332
Amendments to Mineral Laws, Necessary.... 606	606	Australia, Radium Minerals in.....	179	Brackenbury, Cyril, Unwatering Tresavean Mine	566, 616
American Fuel Co., Colorado Lignite Strike Situation	595	Australia, The Occurrence of Tin.....	746	Brady, F., Carbondale Mine Fire, 340—Gasoline From Oil Well Gas, 49—Vanadium, Its Properties and Metallurgy.....	106
American Gem Mines and Mining.....	103	Australia, Weathering of Coal Seams.....	273	Brass and Bronze Alloys.....	670
American Institute of Mining Engineers, California Meeting, 1911.....	294	Austria, Quicksilver Works in.....	427	Brazilian Carbons.....	732
American Institute of Mining Engineers, February, 1912, Meeting.....	471, 519	Automatic Drainage.....	408	Brazil Offers Prospectors, What.....	235
American Mining Congress.....	258	Automatic Switch for Shaft Bottoms.....	408	Breaker, The Buck Mountain Coal.....	637
American Mining Congress and Colorado Scientific Society.....	260	B. & K. COAL JIG, THE.....	209	Breathing Apparatus, Artificial.....	661
American Mining Congress Meeting, Postponement of.....	129	Bahney, Prof. Luther W., Estimating Alkalinity in Lime.....	368	Breckenridge Placers, Geology of the.....	430
American Mining Congress, Revision of Mineral Land Laws.....	260	Baird, Dugald, Wire Rope as Applied to Mining	404	Briceville, Tenn., Coal Mine Disaster.....	322
Amherst, Quebec, Graphite Deposits.....	573	Balance Rest, Concrete.....	623	Briceville, Tenn., Cross Mountain Mine Explosion	393
Annabelle Mines, Modern Steel Tipple at.. 146	146	Bannister, C. O., Blast Roasting of Galena.. 62	62	Briquets, Nomenclature for Coal.....	577
Annual First-Aid Contests.....	146	Barbour, Percy E., Ely Mining District.. 33	416	British Rescue and Aid Act.....	516
Anode Residues—Correction.....	636	Barnes, J. J., Hoisting by Electricity.....	416	British Rescue and Aid Order.....	21
Anode Residues, Treating Copper.....	622	Bartlett, C. O., Workmen's Liability Insurance	412	Broken Hill, Australia, Refining Base Bul lion	423
Another "Chicken Bill" Yarn.....	248	Barytes an Important Mineral.....	252	Broken Hill Ores, Treatment of.....227, 315,	381
Anthracite, Calorific Value of.....	72	Bauxite and Aluminum Production.....	503	Brown Hematite Mining in Virginia.....	553
Anthracite Mine Accidents, To Decrease.... 636	636	Bauxite Mining in Tennessee.....	419	Bruceton, Pa., Explosion.....	596
Anthracite Mine Law.....	575	Bauxite Production in 1909.....	369	Bryden, C. L., Glück Auf.....	517
Anthracite Mine Laws, Commission to Revise	400	Baydon, H. C., Chilian Mills and Amalgamation, 108—Notes on Chilian Mills in Russia	177	Bucherer, L., Hydraulic Filling in European Mines	641, 715
Anthracite Mining Statistics, 1909.....	351	Beard, J. T., Rolling Friction.....	90	Buck Mountain Coal Breaker.....	637
Anthracite Output, 1911.....	400	Bell, R. M., Mines in Pioche, Nevada District, 243—Pioche, Nevada District.....	163		
Anthracite Record Broken (First Six Months 1911).....	8	Belt Screens	685		
		Benjamin, E., Position of Stoppings to Withstand Explosions.....	703		
		Berwind-White vs. Farmers.....	27		

	Page		Page		Page
Buckner No. 2 Mine of the United Coal Co.	272	China, Minerals in	572	Cochrane, Ontario, Chimney Gold	40
Buffum, F. D., Tests for Oil Wanted	535	China, Mining Regulations in	304	Coghill, Will H., An Outline of Mining	34
Bullion, Reining of Base	433	Chinese Coal for the United States	537	Cokedale, Swinging Rock Dump at	48
Bully for the Old Five-Gallon Oil Can	734	Chinese Laws Concerning Mine Accidents	618	Coke for Foundry Purposes	458
Bunson Coal Co., Universal Mine	131	Chino Copper Co.	668	Coke Making in Italy	408
Burchell, George B., Grades for Rope Hauls	401	Chino Copper Mine	633	Coke Ovens in America, By-Product	530
Burette Stand, A Convenient	692	Chlorination and Cyanide Process, Cost	562	Coke Oven Practice, Improved	720
Burgess, Wm. T., M-Curtain Mine Disaster	703	Chocks for Chain Hauls	73	Coke Ovens, Waste-Heat (Stag Cañon Fuel Co.)	142
Burkhard, E. D., First-Aid Work and First-Aid Contests	334	Christensen, Charles C., A Twentieth Century Cyanide Plant, 35—Copper Smelting Furnaces	186	Coke Production in the United States, 1911	400
Burrell, G. A., Apparatus for Detecting Marsh Gas, 70—Atmospheres That Extinguish Flames, 65—Mine Gas Investigations	532	Chute Hook at Radiant Mine	41	Coker Creek Gold Field	547
Burr, Floyd L., Square-Set Mining at Vulcan Mines	613	Chutes in Gaseous Mines, Ventilating Blind Chute, Waterfall	20	Colburn Mill, Tailing Disposal Device at	748
Burroughs, Wilbur G., Dry Placer Mining Methods	486	Cinderella Consolidated Gold Mining Co., Electric Sinking Hoists	624	College of Mines, University of Washington, Short Session	324
Burt Revolving Filter, The	234	Cirkel, Fritz, Amherst, Quebec, Graphite Deposits	573	Colorado Fuel & Iron Co., Rockvale New Air Slope, 653—Dropping-In Arrangement	271
Butler, J. E., Coal Developments at Stearns By-Product Coke Ovens in America	530	Civil Service Examinations	465	Colorado Iron Works Co., Blast-Furnace Smelting With Oil	249
CALAFATITA	681	Clara Consolidated Gold & Copper Mining Co., Arizona	41	Colorado Lignite Strike Situation	595
Calcium Chloride as a Dust Preventative	73	Clarke, William, Early Shot Firers	159	Colorado School of Mines	323
Calculations in Ore Concentrations	188	Clark, H. H., Electrical Symbols for Mine Maps	473	Colorado Scientific Society	323
California Dredging Costs, Reducing	678	Clemens, A. B., Rolling Friction	90	Colorado Scientific Society and American Mining Congress	260
California, High Grade Mining District	681	Cleveland-Cliffs Iron Co., Surveying and Sampling Drill Holes	167	Colorades Coal Production, 1911	400
California Natural Gas Law	612	Clinkering of Coal	526	Colorado, The Puritan Mine	140
Callow Screen	685	Clock Face Colliery	270	Colorimetric Estimation of Gold	126
Calorific Value of Anthracite	72	Cloth Pinions for Electric Motors	570	Colliery Gas Engine Plants	337
Calumet and Arizona, Hoisting at	485	Coal, Clinkering of	526	Combating Miners' Diseases	653
Calumet and Hecla Consolidation, The	129	Coal Combustion Recorders	96	Combustion Recorders, Coal	96
Cameron, J. M., Cranberry Iron Ore Mine	42	Coal, Conservation of	258	Comments on the San Bois, Okla., Disaster	576
Cameron, James, General Haulage of Coal	200	Coal Cutter, Jeffrey-O'Toole	466	Commission to Revise Anthracite Mine Laws	460
Cameron Mine, Dropping-In Arrangement	271	Coaldale Head-House	67	Common Features of Silver Districts	296
Cameron Mine, Rock Dump	158	Coal Developments at Stearns, Ky	481	Como No. 5 Mine	66
Canada, Placer Mining in Quebec	422	Coal Dust	401	Compass Needle, Variations of the	750
Canadian Blast Furnace	40	Coal Dust and Zone Systems	23	Compensation for Mine Workers	267
Canadian Mining Institute, December, 1911, Meeting	447	Coal Dust (Ashworth)	85	Composition of Mine Gases	532
Canadian Mining Institute, March, 1912, Meeting	460	Coal-Dust Explosions and Air	350	Compressor Explosion, Air	651
Cananea Consolidated Copper Co.	40	Coal-Dust Explosions, History of	707	Compressor Lubrication, Air	664
Candles in the Transvaal, Use of	742	Coal-Dust Explosions	78	Concentrating Table, Diagonal Plane	44
Canvas Table	731	Coal Field of West Virginia, Smokeless	467	Concentration, Rotary Tray	428
Capacity of Siphon	535	Coal Fields, Dawson-Mackenzie	257	Concentrations, Calculations in Ore	188
Carbondale Mine Fire	340	Coal Fields, Weathering	257	Concrete Balance Rest	623
Carbons, Brazilian	732	Coal for Spain	14	Concrete Construction, Oscillating Screens and	159
Car Door Latch, Mine	648	Coal for United States, Chinese	537	Conditions in the Katanga	731
Careless Blasting, Bisbee, Ariz.	40	Coal Geology of West Virginia	12	Conduct of First-Aid Contests	266
Carmichael-Bradford Process	315	Coal Industry of Nova Scotia	69	Conner, Eli T., Wanted—Coal Mine Managers	526
Carnegie, J. E., Occurrence of Tin	746	Coal in Honduras, Oil and	77	Connor, C. R., Relieving Accumulations of Gas	409
Car Spotter	350	Coal in Iowa, Cost of Mining	216	Considerations Before Opening Mines	682
Cartledge, Oscar, Mine No. 3, Saline County Coal Co., 757—Track Arrangement for Shaft Bottoms	336	Coal in Storage, Deterioration of	475	Conservation of Coal	258
Car, Victor-American Fuel Co.'s Instruction	348	Coal Land Legislation, Western	277	Conservation of Minerals	152
Cascade Coal & Coke Co., Disaster at Sykesville	2	Coal Land Statistics, 1909	351	Consolidated Coal Washery at Saginaw, Mich.	468
Caspian Mine, Top Slicing at the	733	Coal Measures, Lookout Mountain	654	Consolidation Coal Company, Explosions From Natural Gas	15
Cast-Iron Water-Jacket	55	Coal Mine Management, Scientific	459	Consolidation Gil Co., Method of Testing Miners' Oil	82
Castle Gate Tipple, Safety Blocks at	141	Coal Mine Shaft Pillars	348	Construction and Application of Curves	521
Catlett, Charles, Phosphorus in Coking Coal Caving and Substopping, Block	674	Coal Mining in Arkansas	9, 66	Convenient Burette Stand	692
Cement Injection, Shaft Sinking by	502	Coal Mining in Michigan	148	Converter, Oil Fired	565
Centrifugal Mine Ventilators	223	Coal Mining Institute of America	28	Converting Basic Slag Into Fertilizer	36
Cerium Tin Alloys	632	Coal Mining Institute of America, December, 1911, Meeting	324	Conway, P. J., Position of Stoppings to Withstand Explosions	659
Chain Hauls, Chocks for	73	Coal Mining Machinery, Ore and	454	Cooperative Drainage	436
Chance, E. M., Calorific Value of Anthracite	72	Coal Mining Notes	27, 80, 288, 351, 399, 522	Copper Anode Residues, Treating	622
Chanit Mine Explosion	576	Coal Mining Problems, Ore and	513	Copper Assay, Iodide Method of	684
Chart Mine, Okla., Mine Explosion	587	Coal, Phosphorus in Coking	263	Copper Combines and Mergers	612
Change House for Coal Miners	647	Coal, Plan to Get More Large	158	Copper Mining Notes	118
Charley Coal Mine Proprietary, Ltd.	273	Coal Production, Colorado, 1911	400	Copper Ores in Nova Scotia	112
Chart, Mining Costs	518	Coal Production in Japan	88	Copper Production, United States	610
Chase, Frederick M.	714	Coal Production, Michigan, 1911	469	Copper Smelting Furnaces	186
Chase, Thornton, Iodide Method of Copper Assay	684	Coal Production, Tennessee	18	Cornwall, Pa., Magnetite Deposits	99
Chauvort, Regis, Fundamentals in Technical Education, 554, 629, 688—Tin Deposits of El Paso County, Texas	111	Coal, Purchasing Locomotive Fuel	398	Cornwall, Unwearing Tresavean Mine	566, 616
Cherry Creek, Gold Discovery, Denver	241	Coal Sampler, Mechanical Laboratory	139	Correction, Anode Residues	636
"Chicken Bill" Yaan, Another	248	Coal Seams, The Weathering of	273	Correction, Rubbing Surface of Airway	594
Chilian Mills and Amalgamation	108	Coal Seam, Working Vertical Bituminous	703	Correction, Standardization in Coal Washing	535
Chilian Mills in Russia, Notes on	177	Coal, Spontaneous Combustion of	414	Correspondence, Accidents During Second Ten Days of Month, 535—Allowable Error in Closing Survey, 401, 472—Arbitration in the Southwest, 221—Capacity of Siphon, 535—Car Spotter, 350—Coal Dust, 401—Coal-Dust Explosions, 159—Coal-Dust Explosions and Air, 350—Coal Washing, 536, 660—Conduct of First-Aid Contests, 266—Correction, Paul	61
		Coal Strata, Kenova-Quadrangle	522		
		Coal Washery at Saginaw, Mich., Consolidated	468		
		Coal Washing	536, 660		
		Coal Washing at Lahausage	391		
		Coal Washing, Standardization, Correction	535		
		Coal Washing, Standardization in	461		
		Colaba, Ontario, Silver Shipments, 1911	436		
		Colaba Silver Veins	61		
		Colaba's Past and Future	729		

Page	Page	Page
<p>Sterling, 90—Correction, George R. Delamater, 535—Difficulties in Sampling Free Milling Gold Ore, 659—Double Explosions From Powder, 90—Early Shot Firers, 159—Filter Presses, 33—Geometry, 221—Grade for Rope Hauls, 266, 401, 472—Humidifying Mine Air, 535, 659—Influence of Roof on Position of Timbers, 703—Iron Ore in Fulton County, Pa., 594—Legal Interpretations of Technical Terms, 535—McCurtain Mine Disaster, 703—Method of Shaft Plumbing, 594—Method of Working a Vertical Bituminous Coal Seam, 594—Oscillating Screens and Concrete Construction, 159—Panel System of Longwall, 472—Position of Stoppings to Withstand Explosions, 535, 659, 703—Rolling Friction, 33, 90—Rubbing Surface of Airway, Correction, 594—Siphons, 350, 401—Specifications for Oil, 594—Tests for Oil Wanted, 535—Watering Mines, 222—Watering Dust and Employment of Shot Firers, 221—Watering Dust in Utah, 159—Working Vertical Bituminous Coal Seams</p> <p>Cosgrove, J. F., Rolling Friction..... 33 Cost Chart, Mining..... 518 Cost of Milling in Leadville..... 619 Cost of Mining Coal in Iowa..... 216 Cost Per Foot of Driving Drifts, Goldfield, Nev. 738 Costs at Le Roi No. 2 Mines..... 628 Costs, Reducing California Dredging..... 678 Coventry, Tom, Weathering of Coal Seams Cover Picture, Our..... 2, 66, 209 Cowan, John L., American Gem Mines and Mining, 103—Himalaya Tourmaline Mine.. 181 Cox, J. R., Efficiency of Fine Screening Devices 685 Cranberry Iron Ore Mine..... 42 Crawford, Wm. B., Tentative Plan of Shaft Bottom 208 Crichton, C., Electrolytic Assay of Gold Solutions 496 Cripple Creek, Milling at Stratton's Independence 319 Cripple Creek, Portland Mine and Mills... 562 Cross Mountain, Briceville, Tenn., Coal Mine Disaster..... 322 Cross Mountain Mine Explosion..... 393 Crusher Rolls, The Edison..... 299 Crushing Coal for Boiler Use..... 349 Crystal Falls, Time Keeping at..... 241 Culm Flushing in Germany..... 538 Culm Flushing (Origination)..... 321, 385 Cunningham Claims..... 1 Cunningham, John C., Exhaust Steam Turbines at Mines..... 370 Cunningham, W. H., Relieving Accumulations of Gas..... 409 Curtis, F., Laboratory Sizing Tests..... 125 Curves, Construction and Application of..... 521 Curves, Rope Sheave for..... 207 Curves, Showing Mining Costs..... 518 Cutting and Bending Glass Tubes..... 429 Cyanide and Chlorination Process, Cost..... 562 Cyanide Ore, Laboratory Test on..... 666 Cyanide Plant, A Twentieth Century..... 35 Cyanide Solutions, Colorimetric Estimation of Gold..... 126</p> <p>DALRYMPLE, JAMES, HUMIDIFYING MINE AIR..... 535 Danford, Mark O., Victor Electric Safety Lamp 79 Darrow-Hambric Table..... 428 Dawson-Mackenzie Coal Fields..... 257 Dawson-Mackenzie Coal Field, Weathering of Coal Seams..... 273 Dawson, N. Mex., Waste-Heat Coke Ovens.. 142 Dawson, Thomas W., Swimming Pools for Mining Towns..... 276 Dean, Samuel, Coal Dust, 401—First-Aid Work and First-Aid Contests, 334—Humidifying Mine Air..... 659 Death Due to Detonating Caps..... 27 Decision on the Cunningham Claims..... 1 Deep Coal Mine Shafts..... 598</p>	<p>Delagua Mine, Colorado, Tipple at..... 456 Delamater, George R., Coal Washing, 660—Correction, 535—Standardization in Coal Washing 461 D., L. & W., Antiseptic Treatment of Mine Timbers, 706—First-Aid Contest, August, 1911, 146—Mines, Electricity in, 657—Woodward No. 3 Shaft..... 697 Dennington, A. R., Construction and Application of Curves..... 521 Denver, Colo., Cherry Creek Gold Discovery Descriptive Mineralogy of Mica..... 241 Deserved Promotion..... 625 Deterioration of Coal in Storage..... 714 Diagonal Plane Concentrating Table..... 475 Diagram, Mine Management..... 44 Diagrams, Construction and Application of Curves 411 Diagrams, Mining Cost Chart..... 521 Diamond Mine, The Voorspoed..... 518 Diamonds, Brazilian Carbons..... 246 Difficulties in Sampling Free Milling Gold Ore 732 Disaster at Sykesville, Pa..... 84 Disasters, Lessons From Recent Mine..... 524 Disasters, Lessons to be Learned From..... 81 Diseases, Combatting Miners'..... 653 Disposal of Ashes at Mine Boiler Plants... 93 Dixon, Charlton, Brown Hematite Mining in Virginia, 553—Limonite Prospecting and Mining 483 Dodson Colliery, Steel Mine Timbers in..... 215 Dome Mill..... 633 Dome Mine, Porcupine, Ontario..... 635 Double Explosions From Powder..... 90 Drainage, Automatic..... 531 Drainage, Cooperative..... 436 Drainage Tunnel, Panther Creek..... 599 Dredging Costs, Reducing California..... 678 Dredging Up To Date, Gold..... 725 Drifts, Goldfield, Nev., Cost Per Foot of Driving 738 Drill Holes, Surveying and Sampling..... 167 Drinker, Dr. Henry S., Conservation of Minerals 152 Driving the Loetschberg Tunnel..... 37 Dropping-In Arrangement..... 271 Dry-Placer Mining Methods..... 486 Drying Furnaces, Mechanical..... 561 Drying Iron Ore..... 734 Dump at Cokedale, Swing Rock..... 48 Dump, Cameron Mine, Rock..... 158 Duncan, J. C., Three Rails for Motor Gathering 701 DuPont Powder Co., Big Blast at Steins, N. Mex. 539 Durable Shaking Screen..... 676 Duralumin 185 Durham, Edward B., Electrolytic Refining.. 361 Dust and Zone Systems, Coal..... 23, 85 Dust, Coal..... 401 Dust, Coal (Ashworth)..... 218 Dust Explosions, History of Coal..... 707 Dust Preventative, Calcium Chloride as..... 73 Dust, Watering Coal..... 66</p> <p>EARLY SHOT FIRERS 159 Early Watering of Mines and Employment of Shot Firers..... 159 Economical Fire-Room Methods..... 94 Economy in the Use of Steam..... 470 Edison Crusher Rolls..... 299 Editorial 693 1, 65, 129, 193, 257, 321, 385, 449, 513, 575, 633, 693 Education, Fundamentals in Technical, 550, 629, 688 Effect of the Mexican Revolution on Mining 695 Effective Mine Air Humidifier..... 531 Efficiency of Fine Screening Devices..... 685 Election of State Mine Inspectors, The..... 130 Electric Lights for Mines, Portable..... 322 Electric Machinery for Mining..... 66 Electric Mine Lamps..... 65 Electric Mine Lamps (Hirsch)..... 91 Electric Power Plant, Santa Rosa Mining Co., Mexico..... 41</p>	<p>Electric Power on a Steam Hoist, Using.... 721 Electric Safety Lamp, Victor..... 79 Electric Sinking Hoists, Shaft Sinking by.. 624 Electrical Equipment, An English Colliery 270 Electrical Practice in Mines, Overhead..... 284 Electrical Symbols for Mine Maps..... 473 Electricity, Hoisting by..... 416 Electricity in the D., L. & W. Mines..... 637 Electrochemical Society, Twentieth Meeting 254 Electrolytic Assay of Gold Solutions..... 496 Electrolytic Refining..... 361 Elmore Flotation Process..... 124 El Paso Shaft, Cripple Creek, Colo..... 488 Ely Mining District, Nevada..... 62 Empire Mine and Mill, Grass Valley, Cal... 113 Employers' Liability, Compensation for Mine Workers 267 Employes' Aid Fund, Homestake..... 555 Enforced Annual Assessment Work..... 624 Enforced Development of Mining Claims... 246 Enforcement of Mine Laws..... 27 Engineering Society News..... 519 English Colliery Electrical Equipment..... 270 England, First Mining School in..... 414 England, Mine Inspectors' Qualifications in 193 Equipment of Poverty Gulch Mine..... 53 Error in Closing Survey, Allowable..... 401, 472 Estimating Alkalinity in Lime..... 368 Evans, A. W., Lookout Mountain Coal Measures 654 Examinations: Australia, New South Wales, First-Class Certificate, 1911 662 Illinois, Mine Managers and Mine Examiners, Springfield, 1910, 289—Mine Managers, Mine Examiners, and Hoisting Engineers, 1910..... 162, 225 Indiana, Mine Foremen's and Fire Bosses', Terre Haute, 1911..... 353, 417 Pennsylvania, Anthracite Mine Inspectors', Seranton, May, 1911, 31, 97—Bituminous Second Grade Foremen, 1911, 543—Mine Foremen Anthracite, Pottsville, April, 1912 602 Tennessee, Mine Foremen, 1911..... 477 Utah, Mine Foremen's, February, 1911, 161—Mine Foremen's, October, 1911, 722—Mine Foremen's, Carbon County, February, 1911 97 Exhaust Steam Turbines at Mines..... 370 Explosion, Air Compressor..... 651 Explosion, Bottom Creek Mine..... 332 Explosion, Brucecon, Pa..... 596 Explosion, Briceville, Tenn..... 322 Explosion, Chant Mine, Okla..... 587 Explosion, Comments on the San Bois, Okla. 576 Explosion, Cross Mountain Mine, Briceville 393 Explosion, First-Aid Saves Life..... 519 Explosion, Jed, W. Va..... 576, 579 Explosion, Radley Mines, Kansas..... 400 Explosion, Sykesville, Pa..... 84 Explosions, Coal-Dust..... 78, 159 Explosions, History of Coal-Dust..... 707 Explosions From Natural Gas Well, Mine.. 2, 15 Explosions From Powder, Double..... 90 Explosions, Positions of Stoppings to Withstand 659, 703 Explosives in 1909, Manufacture of..... 482 Explosives Used in English Mines, 1910..... 400 Extinguishing the Majestic Mine Fire..... 342</p> <p>FAN, VOLUMETRIC CAPACITY OF..... 475 Fans, Centrifugal Mine..... 223 Filling in European Mines, Hydraulic.... 641, 715 Filter Presses..... 33 Filter, The Burt Revolving..... 234 Firedamp Detector, New..... 266 Fire-Fighting Car, Lehigh Valley..... 71 Fire, Extinguishing the Majestic Mine..... 342 Fire, The Carbondale Mine..... 340 Fire, The Giroux Mine..... 435 Fire-Room Methods, Economical..... 94 Fires in Metal Mines..... 253 Fires, Lessons to be Learned From Mine... 19 Fires, Porcupine Forest..... 123 Fires, Stock Pile..... 217</p>

	Page		Page		Page
First-Aid Contest, Inter-Company, Anthracite	204	Geologic Structure of Silver Districts	358	Henrietta Mine, Reopening the	40
First-Aid Contest, Susquehanna Coal Co.	202	Geological Mapping, Topographical and	312	High Grade Mining District	681
First-Aid Contests, Annual	146	Geology of the Breckenridge Placers	430	Hillside Coal & Iron Co., First-Aid Contest, September, 1911	146
First-Aid Contests, Conduct of	266	Geology of West Virginia, Coal	12	Himalaya Tourmaline Mine	181
First-Aid Contests East and West	201	Geology, Progress in Kentucky	649	Historic Mine, An	66
First-Aid Contests, Rocky Mountain District	294	Geometry	221	History of Coal-Dust Explosions	707
First-Aid Field Day, National (Pittsburg)	61, 147, 257,	Germany, Flushing Appliances in	538	History of Kansas Oil Development	384
	282	Gilbons, G. G., Efficiency of Fine Screening Devices	685	History of the First-Aid Movement	324
First-Aid in Japan	71	Giesecke Tube Mill	102	History of the Safety Lamp	721
First-Aid Movement, History of the	324	Gill, Augustus H., Coal Combustion Records	96	Hoisting Arrangements, Some Kalgoorlie	572
First-Aid Saves Life	519	Gironx Mine Fire	435	Hoisting at Calumet and Arizona	485
First-Aid Work and First-Aid Contests	334	Gironx Mines, Unwatering	429	Hoisting by Electricity	416
First Mining School in England	414	Glass Tubes, Cutting and Bending	429	Hoists at Ray, Ariz., The New Electric	250
Fluxure Veins, Leadville, Colo.	549	Glen Lyon's First-Aid Victory	202	Hoist, Using Electric Power on a Steam	721
Flames, Atmospheres That Extinguish	650	Gluck Auf	491	Holding Leases Without Operating	748
"Flint and Steel," Modern	440	Goats on Coal Lands	154	Hollinger Mine Report, The	498
Flotation Process, The Elmore	124	Gold and Silver Output, 1911	506	Hollinger Report	633
Flotation Process, Treatment of Broken Hill Ores	227	Gold, Colorimetric Estimation of	126	Holmes, Joseph A., Lessons From Recent Mine Disasters	524
Flushing Appliances in Germany	538	Gold Dredging in Foreign Countries	60	Holt, Theo. P., Metallurgy of Mercur Gold Ores	355
Flushing, Hydraulic Filling in European Mines	641,	Gold Dredging Up To Date	725	Home-Made Mining Plant, Remarkable	421
Flushing or Silting Mine Workings (Origination)	321,	Gold Field, Coker Creek	715	Homestake Employes' Aid Fund	555
Following the Ore in Joplin Mines	556	Golden Gate Mill	385	Homestake Mine, President Taft in	369
Forest of Dean Mine	184	Golden Rod Coal Mine Ruling	704	Honduras, Oil and Coal in	77
Forestry to Mining, Relation of	120,	Goldfield, Nev., Cost Per Foot of Driving Drifts	738	Hook-Worm	633
Foreword	1	Goldfield, Nev., Cyanide Mill	610	Horsepower of an Engine	700
Frailey, Irvin, Kenova-Quadrangle Coal Strata	522	Golding, C. E., Miami Concentrating Mill	545	Hoskin, Arthur J., Considerations Before Opening Mines	682
Freezing Process, Shaft Sinking by the Poetsch Method	245	Gold Mining in Siberian District	687	Hoskin, A. J., Topographical and Geological Mapping	312
Freiberg, Passing of Mining at	626	Gold Mining Progress in South Dakota	298	Humidifier, An Effective Mine Air	531
Frick Coke Co., H. C., Appliances for Preventing Accidents, 74—Rational Sociology at Mines, 193—Safety the First Consideration, 5—Safety Through Systematic Timbering, 195—Swimming Pools for Mining Town, 276—Underground Safety Appliances	155	Gold Mining, Revival of	65	Humidifying Mine Air	535, 659
Frauds, The Post Office After Mine	64	Gold Ore, Difficulties in Sampling Free Milling	659	Huntington-Heberlein Process	315
Friction, Rolling	33,	Gold Production, 1910	488	Hydraulic Filling in European Mines	641, 715
Fuel, Purchasing Locomotive	398	Gold Solutions, Electrolytic Assay of	496	Hydrauliclicking With Waste Water	118
Fuller, John T., Grade for Rope Hauls, 472—Timbering a Small Shaft	743	Goodale, Stephen L., Appliances for Preventing Accidents, 74—Safety the First Consideration, 5—Safety Through Systematic Timbering, 195—Underground Safety Appliances	273	Hydraulic Placer Mining, Notes on	507
Fullers' Earth in Texas	379	Goodney, S. J., Shaft Raising in Hard Rock	495		
Fulton County, Pa., Iron Ore in	594	Grades for Rope Hauls	266, 401,	IDAHO METAL OUTPUT, 1911	563
Fume, Settling Chamber for Smelter	125	Graphite Deposits, Amherst, Quebec	90	Illinois, Buckner No. 2 Mine	272
Fundamentals in Technical Education	550, 629, 688	Grass Valley, Cal., Empire Mine and Mill	113	Illinois, Longwall Mining in (Spring Valley)	451
Furnaces, Copper Smelting	186	Gray Creek Mine, Haulage System at	264	Illinois, Mine No. 3, Saline County Coal Co.	387
Furnaces, Mechanical Drying	561	Green River, Utah, Oil Field	41	Improved Coke Oven Practice	570
GAHL, RUDOLPH, CALCULATIONS IN ORE CONCENTRATION	188	Griffith, William, Method of Mining Coal, 402—Method of Supporting Mine Roofs	273	Independence Mill, Stratton's	570
Galena, Blast Roasting of	607	Grub Stake, A 10,000 Dollar	40	Influence of Roof on Position of Timbers	703
Galloway, A. A., Using Electric Power on a Steam Hoist	721	Gypsum in Nova Scotia	64	Inkstand, Making a Cardboard	538
Garnet Veins on Labrador Coast	357	HAAS, FRANK, WEST VIRGINIA MINING INSTITUTE (JUNE, 1911, MEETING)	29	Inspection in Missouri, Ore Mine	173
Gas, Apparatus for Detecting Marsh	702	Hackett Mining Co., Treating Low-Grade Zinc Ore	115	Inspectors, Appointment of H. M.	220
Gas Consumer, Furnace	584	Hale, T., Coal Production in Japan	88	Inspectors, Appointment of Ohio Mine	18
Gas Engine Plants, Colliery	337	Hale, Henry, Reviving Suffocated Miners	661	Inspectors, Election of State Mine	130
Gas Investigations, Mine	532	Haley, Justice to Inspector	694	Inspectors' Examination (See Examination Questions)	31
Gas Law, California Natural	612	Hampton Water Hoist	658	Inspectors' Qualifications in England, Mine	193
Gas, Liquefied Products From Natural	583	Handley, H. L., Grades for Rope Hauls	266	Inspectors, Selection of State Mine	634
Gas, Making Gasoline From Oil Well	49	Hanratty, Pete, Early Watering of Mines and Employment of Spot Firers	159	Institute Meetings	217
Gas, Production of Natural	294	Harger, H. S., Voorspoed Diamond Mine	247	Instruction Car, Victor-American Fuel Co.'s	348
Gas Pump, The Smith	705	Harrison, George, Golden Rod Coal Mine Ruling, 704—Legality of Changed Mine Openings	701	Insurance, Workmen's Liability	412
Gas, Relieving Accumulations of	409	Hartford Mine Fire	40	Inter-Company First-Aid Contest	204
Gas Well, Mine Explosions From Natural	15	Haulage, Dropping-In Arrangement	271	Internal Combustion Engines in Mines	8
Gases From Boilers, Analyses of	94	Haulage of Coal, General	200	International Smelter at Tooele, Utah	56
Gasoline Engines in Mines in Europe	8	Haulage, Gasoline Industrial Locomotives	737	Iodide Method of Copper Assay	684
Gasoline From Oil Well Gas, Making	49	Haulage, Practical Coal	650	Iowa, Cost of Mining Coal in	216
Gasoline Industrial Locomotives	737	Haulage System at Gray Creek Mine	264	Iron Bearing Materials, Sintering Fine	559
Gasoline Mine Locomotives, Testing	341	Haulage, Three Rails for Motor	701	Iron Mines, The Cornwall, Pa.	99
Gate for Top of Coal Mine Shaft	598	Hauls, Grade for Rope	401, 472	Iron in Australia	482
Gate, Shaft, Strong Mine, Victor, Colo.	233	Hazard Mfg. Co.	222	Iron Ore in Fulton County, Pa.	594
Gathering, Three Rails for Motor	701	Health Commission, Queensland Miners'	441	Iron Ore in 1911	448
Gayley, James, Sintering Fine Iron Bearing Materials	559	Heap Poasting of Slimes	317	Iron Ore Mine, The Cranberry	42
Gem Mines and Mining, American	103, 181	Heilwood, Pa., Penn-Mary Coal Co.	261	Iron Ore, Removing Moisture From	734
General Haulage of Coal	260	Helmswood, The Model Mining Town	210	Iron-Ore Treatment Plant, Spanish	237
General Ore Mining Notes	121, 182	Helmet in High Temperatures, Use of Oxygen	335	Iron Sprag at Radiant Mine	18
Genesis of Silver Deposits	504	Hematite Mining in Virginia, Brown	553	Irrigation with Artesian Waters in Australia	374
		Henderson, Charles W., Mining in Poverty Gulch Mine	53, 116	Italy, Coke Making in	408
				It Is To Laugh	501
				JACKA, J. S., STANDARD BOILER HOUSE	255
				Japan, Coal Production in	88
				Jarman, Arthur, Mining Ore at Talisman Mine	443
				Jed, W. Va., Mine Explosion	576, 579
				Jeffrey Mfg. Co., Crushing Coal for Boiler Use	349
				Jeffrey-O'Toole Coal Cutter	466
				Jennings, J. T., Electric Mine Lamps	91

	Page		Page
Jet Making in England.....	269	Leisenring No. 1, Swimming Pools for	276
Jig, B. & K. Coal.....	209	Mining Towns.....	628
Jones, John H., Compensation for Mine	267	Le Roi No. 2 Mines, Cost at.....	19
Workers.....		Lessons to Be Learned From Mine Fires...	524
Johnson, R. G., Shafts for American Coal	344	Lessons From Recent Mine Disasters.....	81
Mines.....		Liability, Employers, Compensation for Mine	267
Johnson, W. L. A., Arbitration in the South-	221	Workers.....	412
west.....		Liability Insurance, Workmen's.....	368
Joplin District, 1911.....	447	Lime, Estimating Alkalinity in.....	483
Joplin Mines, Following the Ore in.....	556	Limonite Prospecting and Mining (Virginia)	666
Joplin Zinc Notes.....	187	Linderfelt & Stewart, Laboratory Test on	705
Justice to Inspector Haley.....	694	Cyanide Ore.....	737
KALGOORLIE HOISTING ARRANGE-		Liquefied Products from Natural Gas.....	507
MENTS, SOME.....	572	Lloyd, W. Bert, The Smith Gas Pump.....	451
Kanawha Chemical Fire Engine Mfg. Co....	222	Locomotives, Gasoline Industrial.....	472
Kanite Explosives.....	11	Locomotives, Internal Combustion Engines	654
Kansas Oil Development, History of.....	384	in Mines in Europe.....	699
Kansas, Zinc-Lead Production of, 1911....	433	Locomotives, Testing Gasoline Mine.....	679
Kapp-Kunze Process.....	317	Loetschberg Tunnel, Driving the.....	54
Katanga, Conditions in.....	731	Loggin, N. A., Notes on Hydraulic Placer	530
Kenova-Quadrangle Coal Strata.....	522	Mining.....	467
Kentucky College of Mines and Metallurgy..	27	Longwall Mining in Illinois (Spring Valley)	341
Kentucky Geology, Progress in.....	649	Longwall, Panel System of.....	37
Ketchikan District, Alaska, Progress in....	41	Lookout Mountain Coal Measures.....	507
Kickback, Heaton Mine, Gibson, N. Mex....	454	Loomis Shaft.....	451
Knabenshue, S. S., Chinese Coal for United	537	Los Angeles Aqueduct, Bonus System on....	472
States.....		Low, F. R., Economical Fire-Room Methods	654
Krebs, C. E., Panel System of Longwall	70	Low Moor Mines.....	699
Mining.....		Lubricant for Air Compressors.....	593
Krom, S. Arthur, Diagonal Plane Concentr-	44	Lubrication, Air Compressor.....	737
ating Table.....		Lubrication, Oils for.....	664
LABORATORY SIZING TESTS.....	125	Lucas, F. E., By-Product Coke Ovens in	26
Laboratory Test on Cyanide Ore.....	666	America.....	530
Labrador Coast, Garnet Veins on.....	357	Ludlow, Edwin, Mine Management Diagram,	467
Lackawanna Chemical Society, Officers.....	520	411—Smokeless Coal Field of West Virginia	527, 646
Lake of the Woods Mining District.....	665	MACDONALD, BERNARD, PARRAL	305
Lake Superior Copper Notes.....	497	TANK AS A SLIME AGITATOR.....	102
Lake Superior Mining Institute.....	27	Mackie, R. G., Giesecke Tube Mill.....	227
Lake Superior Mining Institute Meeting,	191	Magnetic Concentration, Treatment of Bro-	46
August, 1911.....		ken Hill Ores.....	731
Lakes, Arthur, Geology of Breckenridge	725	Magnetic Separation of Ores (Joplin, Mo.)..	342
Placers, 430—Gold Dredging Up To Date..	185	Magnetic Separators.....	538
Lakes, Harold, An Ore Mine Tromp.....	721	Magnetite Deposits, The Cornwall, Pa.....	49
Lamp, History of the Safety.....	65	Mail, Reply Postage on Foreign.....	374
Lamps, Electric Mine.....	91	Majestic Mine Fire, Extinguishing.....	411
Lamps, Electric Mine (Hirsch).....	536	Making a Cardboard Inkstand.....	526
Langerfeld, Arthur, Coal Washing.....	391	Making Gasoline From Oil Well Gas.....	107
Lahausage, Coal Washing at.....	471	Malay States, Tin Mining in the Federated	33
Larry, Penn-Mary Rock.....	239	Management Diagram, Mine.....	482
Laschinger, E. J., Air-Lift Agitation of	648	Managers, Wanted—Coal Mine.....	623
Slime Pulp.....	516	Manganese in Iron and Steel.....	619
Latch, Mine Car Door.....	612	Manganese in South Africa.....	312
Law, British, Rescue and Aid.....	704	Manganese in South Africa.....	473
Law, California Natural Gas.....	701	Manufacture of Explosives in 1909.....	127
Law, Golden Rod Coal Mine Ruling.....	450	Manufacture of Oxygen.....	492
Law, Legality of Changed Mine Openings,	527, 575	Map of United States, Topographic.....	703
Ohio.....		Mapping, Topographical and Geological....	209
Law, New Russian Mine.....	694	Maps, Electrical Symbols for Mine.....	460, 604
Law of Pennsylvania, 1911 Bituminous	644	Marcasite, Notes on Pyrite and.....	675
Mining.....		Martin, Al. H., Empire Mine and Mill, Grass	438
Law, The Anthracite Mine.....	694	Valley, Cal., 113—Reducing California	492
Law, The Oklahoma Mine.....	644	Dredging Costs, 678—Rotary Tray Concen-	703
Laws and the Coal Industry, Antitrust.....	267	tration.....	304
Laws, Compensation for Mine Workers.....	618	Marvin, N. R., The B. & K. Coal Jig.....	438
Laws Concerning Mine Accidents, Chinese..	606	Matteson, W. G., Common Features of Sil-	492
Laws, Mining Regulations in China.....	260	ver Districts, 296—Genesis of Silver	492
Laws, Necessary Amendments to Mineral..	180	posits, 504—Geologic Structure of Silver	492
Laws, Revision of Mineral Land.....	120, 180	Districts, 358—Minerals Common to Silver	492
Lawson, J. F., Relation of Forestry to	491	Deposits.....	492
Mining.....		McClave, James M., Milling the Tam	492
Lead, Breaking Hot Bars.....	549	O'Shanter Ore.....	492
Leadville, Cost of Milling in.....	748	McCurtain Mine Disaster.....	492
Leads Without Operating, Holding.....	146	McCurtain, Okla., Mine Explosion at.....	492
Lehigh & Wilkes-Barre Coal Co., First-Aid	599	McEachern, Wm. A., Top Slicing at the Cas-	492
Contest, 1911.....		pien Mine.....	492
Lehigh Coal & Navigation Co., Coaldale	71	McMurtry-Rogers Process.....	492
Head-House, 67—New President, 714—Pan-	535	McNatt, J. Q., Automatic Switch for Shaft	492
ther Creek Drainage Tunnel.....		Bottoms, 408—Chute Hook at Radiant Mine,	492
Lehigh Valley Coal Co., Buck Mountain	701	41—Geometry, 221—Iron Sprag at Radiant	492
Breaker, 637—Fire-Fighting Car.....	277	Mine.....	492
Legal Interpretations of Technical Terms..	277	Mee, George H., What Brazil Offers Pros-	492
Legality of Changed Mine Openings.....	277	pectors.....	492
Legislation, Western Coal Land.....	277	Mechanical Drying Furnaces.....	492
		Mechanical Laboratory Sampler.....	492
		Mechanical Sampling of Ores.....	492
		Mercur Gold Ores, Metallurgy of.....	492
		Metallurgy of Mercur Gold Ores.....	492
		Metal Mine Fire.....	492
		Metals, Brass and Bronze Alloys.....	492
		Method of Mining Coal.....	492
		Method of Shaft Plumbing.....	492
		Method of Smelting With Oil.....	492
		Method of Supporting Mine Roofs.....	492
		Method of Testing Miners' Oil.....	492
		Method of Working a Vertical Bituminous	492
		Coal Seam.....	492
		Mexican Revolution on Mining, Effect of the	492
		Mexico, Mineral District of Rayon.....	492
		Miami Concentrating Mill.....	492
		Miami, Okla., Mining Camp.....	492
		Mica, Descriptive Mineralogy of.....	492
		Michigan, Coal Mining in.....	492
		Michigan Coal Production, 1911.....	492
		Michigan Mine Valuations.....	492
		Mill, Goldfield, Nev., Cyanide.....	492
		Mill, Miami Concentrating.....	492
		Milling at Stratton's Independence.....	492
		Milling in Leadville, Cost of.....	492
		Milling the Tam O'Shanter Ore.....	492
		Milwaukee Locomotive Mfg. Co.....	492
		Mine Car Door Latch.....	492
		Mine Explosion at McCurtain, Okla.....	492
		Mine Explosions From Natural Gas Well....	492
		Mine Fires, Lessons to Be Learned From... 19	492
		Mine Gas Investigations.....	492
		Mine Inspectors' Annual Meeting, June, 1911 30	492
		Mine Inspectors, Election of State.....	492
		Mine Inspectors, Selection of State.....	492
		Mine Inspectors' Qualifications in England.. 193	492
		Mine Law, Pennsylvania Bituminous 1911	492
		Mine Law, The Anthracite.....	492
		Mine Management Diagram.....	492
		Mine No. 3, Saline County Coal Co.....	492
		Mine Officials of the Future.....	492
		Mineral District of Rayon.....	492
		Mineral Land Laws, Revision of.....	492
		Mineralogy of Mica, Descriptive.....	492
		Mineral Output of the World.....	492
		Minerals Common to Silver Deposits.....	492
		Minerals in China.....	492
		Mineral Spring Breaker, Our Cover Picture 2	492
		Minerals, Conservation of.....	492
		Miners' Diseases, Combatting.....	492
		Miners' Health Commission, Queensland.... 441	492
		Miners in Arkansas.....	492
		Mine Rules and Mine Laws.....	492
		Mines in Pioche, Nevada, District.....	492
		Mine Stable Management.....	492
		Mine Survey Notes.....	492
		Mine Valuations, Michigan.....	492
		Mining a Business Investment.....	492
		Mining and Engineering World Purchases	492
		Pacific Miner.....	492
		Mining and Metallurgical Society of America 542	492
		Mining Claims, Enforced Development of.. 246	492
		Mining Coal, Method of.....	492
		Mining Cost Chart.....	492
		Mining Educational Institutes.....	492
		Mining in Poverty Gulch Mine.....	492
		Mining Institute Banquet, Wilkes-Barre... 541	492
		Mining in Tintic District, Utah.....	492
		Mining in Uruguay.....	492
		Mining Machinery, Ore and Coal.....	492
		Mining Ore at the Talisman Mine, New Zea-	492
		land.....	492
		Mining, Outline of.....	492
		Mining, Panel System of Longwall.....	492
		Mining Regulations in China.....	492
		Mining, Relation of Forestry to.....	492
		Mining Societies.....	492
		Mining Society and Educational Notes.....	492
		Mining Society, University of Illinois.....	492
		Mint, Electrolytic Refining, San Francisco.. 361	492
		Missouri, Ore Mine Inspection in.....	492
		Missouri, Zinc-Lead Production of 1911.... 433	492
		Missouri, Zinc Mining in.....	492
		Model, Stope.....	492
		Modern "Flint and Steel".....	492
		Modern Steel Tipple at Annabelle Mines... 325	492
		Moistener, An Effective Mine Air.....	492
		Montana Smelters.....	492

	Page		Page
Montezuma, Tam O'Shanter.....	492	Oklahoma, Petroleum in.....	291
Moistening Mine Air.....	535, 659	Oklahoma, Zinc-Lead Production of, 1911.....	433
Moore, A. J., Proposed Modification of the Square Set.....	302	Opening Mines, Considerations Before.....	682
Motor Car For Mine Rescue Work.....	517	Ore and Coal Mining Machinery.....	454
Mules, Mine Stable Management.....	534	Ore and Coal Mining Problems.....	513
NANTICOKE POWER HOUSE.....	658, 700	Ore Concentrations, Calculations in.....	188
National First-Aid Field Day (Pittsburg).....	61, 147	Ore Mine Inspection in Missouri.....	173
National First-Aid Meet, Pittsburg.....	257, 282	Ore Mine Tromp, An.....	185
National Fuel Co., Self-Oiling Tail-Rope Roller.....	281	Ore Mining Notes.....	40, 121, 182, 309, 378, 433, 501, 563, 729
National Mine Safety Demonstration.....	69	Oscillating Screens and Concrete Construction.....	159
Natural Salt Deposit.....	238	O'Toole Coal Cutter, Jeffrey.....	466
Navajo Mine, Boiler Coal Elevator.....	640	Oxygen Breathing Apparatus.....	661
Navajo Mine, New Mexico, Switch at.....	664	Oxygen Helmet in High Temperatures, Use of.....	335
Necessary Amendments to Mineral Laws.....	606	Oxygen, Manufacture of.....	623
Nevada Consolidated Copper Co.....	729	Oxygen Stretcher.....	406
Nevada, Pioche District.....	163	Overcasts With Light Walls.....	515
Nevada, Zinc Mines of Southern.....	671	Overhead Electrical Practice in Mines.....	284
New Brunswick, Shale-Oil Enterprise in.....	472	Overproduction in Mine Shares.....	449
New Electric Hoists at Ray, Ariz.....	250	Ovitz, F. K., Deterioration of Coal in Storage.....	475
New Firedamp Detector.....	266	Our Cover Picture.....	2, 66, 209, 636
Newfoundland, Slate and Marble in.....	367	Outline of Mining.....	34
"New Metallurgy," The.....	739	PALMER, LEROY A., INTERNATIONAL SMELTER AT TOOELE, UTAH, 56—MINING IN TINTIC DISTRICT, UTAH.....	375
New Mexico, Chino Copper Co.....	668	Panel System of Longwall Mining.....	70, 599
New President of the Lehigh Coal & Navigation Co.....	714	Panther Creek Drainage Tunnel.....	599
New Russian Mine Law.....	450	Parral Tank as a Slime Agitator.....	305
New Zealand, Gold Dredging, 60—Mineral Oil, 465—Mining Ore at Talisman Mine, 443—Prevention of Miners' Phthisis.....	745	Parting Tray.....	670
Nicholl, John S., Mechanical Drying Furnaces, 561—Removing Moisture From Iron Ore.....	734	Passing of Mining at Freiberg.....	626
Nickel-Zinc Alloys.....	555	Pacific Miner Purchased by Mining and Engineering World.....	259
1911 Bituminous Mining Law of Pennsylvania.....	527, 646	Penn-Mary Coal Co. Plant.....	261
Nogales District, Mexico.....	422	Penn-Mary, Heilwood, The Model Mining Town.....	210
Nomenclature for Coal Briquets.....	577	Penn-Mary Rock Larry.....	471
North Carolina, Mineral Production of, 1910.....	379	Pennsylvania Anthracite Statistics, 1909.....	351
Norwegian Mineral Production.....	244	Pennsylvania, 1911 Bituminous Mining Law.....	527, 646
Not Much But Some.....	577	Pennsylvania Coal Co., First-Aid Contest, September, 1911.....	146
Notes, See Coal Mining Notes, Ore Mining Notes, Zinc and Lead Notes.....	213	Perkins, Frank C., Colliery Gas Engine Plants, 337—Gasoline Industrial Locomotives, 737—Motor Car For Mine Rescue Work, 517—Oil-Fired Converter, 565—Remarkable Home-Made Mining Plant, 421—Sixteen Tons of High Explosive in a Blast, 437—Tesorero Mine Tramway, 571—Wooden-Stave Water Pipe.....	620
Notes, Mine Survey.....	177	Pern Mineral Industry.....	369
Notes on Chilean Mills in Russia.....	507	Peru, Silver Mining in.....	360
Notes on Hydraulic Placer Mining.....	127	Perversity of Miners.....	497
Notes on Pyrite and Marcasite.....	69	Petrolia, Henrietta, and Electra Oil Fields.....	623
Nova Scotia, Coal Industry of.....	112	Petroleum in Borneo.....	95
Nova Scotia, Copper Ores in.....	52	Petroleum in Oklahoma.....	291
Nova Scotia Oil Fields.....	40	Petroleum in South Africa.....	399
Nye County, Nevada, Silver Mine.....	746	Petroleum Wells of Ontario, 1910.....	141
OCCURRENCE OF TIN, THE.....	400	Philadelphia & Reading Coal and Iron Co., Chocks for Chain Hauls.....	73
Ohio Accidents in 1911.....	400	Philadelphia & Reading First-Aid Contest, September, 1911.....	146
Ohio Brass Co., Overhead Electrical Practice in Mines.....	284	Phonolith as a Fertilizer.....	574
Ohio, Golden Rod Coal Mine Ruling.....	704	Phosphate Rocks, Tennessee.....	621
Ohio, Legality of Changed Mine Openings.....	701	Phosphorus in Coking Coal.....	263
Ohio Mine Inspectors, Appointment of.....	18	Phthisis, Prevention of Miners'.....	745
Oil and Coal in Honduras.....	77	Pillars, Coal Mine Shaft.....	214
Oil, Blast-Furnace Smelting With.....	249	Pinions for Electric Motors, Cloth.....	570
Oil Can, Bully for the Old Five-Gallon.....	343	Pioche, Nevada, District, Mines in.....	163, 620
Oil Development, History of Kansas.....	384	Pipe, Wooden-Stave Water.....	620
Oil in Trinidad.....	256	Pittsburg-Buffalo Inspection Committee.....	27
Oil Field, Roumania's Newest.....	276	Pittsburg Coal Operators' Association, First-Aid Contest, September, 1911.....	146
Oil Fields of Chile.....	684	Pittsburg Mine of California.....	41
Oil Fields, Nova Scotia.....	52	Pittsburg, The National First-Aid Meet.....	257, 282
Oil Fields, Petrolia, Henrietta and Electra.....	623	Pittsburg, National Mine Safety Demonstration.....	69
Oil Fired Converter.....	565	Placer Mining Methods, Dry.....	486
Oil, Method of Smelting With.....	165	Placer Mining in Quebec, Canada (Beauceville).....	422
Oil, Method of Testing Miners'.....	82	Placer Mining, Notes on Hydraulic.....	507
Oil, New Zealand Mineral.....	465	Plan to Get More Large Coal.....	158
Oil, Petroleum in Oklahoma.....	291	Platinum Production, Russian.....	291
Oil Process, Treatment of Broken Hill Ores.....	26	Plumb, C. H., Miami, Okla., Mining Camp.....	627
Oils for Lubrication.....	594	Plumbing, Method of Shaft.....	594
Oil Specifications for.....	535	Pocahontas Coal and Coke Shipments.....	592
Oil Tests Wanted.....	49	Poetsch Method, Shaft Sinking by.....	245
Oil Well Gas, Making Gasoline From.....	576	Poole, W., Refining Base Bullion, 423—Treating Zinc Crusts and Drosses, 498—Treatment of Broken Hill Ores.....	227, 315, 381
Oklahoma Disaster, Comments on the San Bois.....	587	Porcupine Forest Fires.....	123
Oklahoma, Mine Explosion at McCurtain.....	694	Porcupine, Overproduction in Mine Shares.....	449
Oklahoma Mine Law, The.....	627	Portable Electric Lights for Mines.....	322
Oklahoma Mining Camp, Miami.....	627	Portable Electric Safety Light Co.....	222
		Portland Mine and Mills.....	562
		Port Pirie Smelting Works, Treatment of Broken Hill Ores.....	381
		Porter, Horace C., Deterioration of Coal in Storage.....	475
		Porter, J. B., Efficiency of Fine Screening Devices.....	685
		Position of Stoppings to Withstand Explosions.....	535, 659, 703
		Postage on Foreign Mail, Reply.....	731
		Post Office After Mine Frauds.....	64
		Postponement of American Mining Congress Meeting.....	129
		Poverty Gulch Mine, Equipment of the.....	53
		Poverty Gulch Mine, Mining in.....	116
		Power to Drive a Fan.....	265
		Powder Strike.....	27
		Practical Coal Haulage.....	650
		President Taft in the Homestake Mine.....	369
		Prevention of Miners' Phthisis.....	745
		Prevention of Smoke by Combustion.....	584
		Process Fakes and Business Men.....	128
		Production of Natural Gas.....	294
		Profit and Loss Account.....	83
		Progress in Kentucky Geology.....	649
		Proposed Modification of the Square Set.....	302
		Pulmotor.....	661
		Pulp, Air-Lift Agitation of Slime.....	239
		Pulverizer for Assayers.....	560
		Pump and Siphon Combined.....	531
		Pumps, Turbine Mine.....	287
		Purchasing Locomotive Fuel.....	398
		Puritan Mine, The.....	140
		Pyrite and Marcasite, Notes on.....	127
		QUEENSLAND MINERS' HEALTH COMMISSION.....	441
		Quicksilver Works in Austria.....	427
		Quick Tape Repair Bands.....	416
		Quinckel, R. D., Purchasing Locomotive Fuel.....	398
		RADIANT MINE, CHUTE HOOK AT.....	41
		Radium in Australia.....	558
		Radium Minerals in Australia.....	179
		Radley Coal Mines Explosion.....	400
		Raising in Hard Rock, Shaft.....	495
		Raising Rope to Knuckle, Spiral for.....	542
		Ralston, Oliver C., Cost of Milling in Leadville, 619—Leadville, Colo., Fissure Veins.....	549
		Rand Proprietary Mines, "New Metallurgy".....	739
		Randolph, Beverley S., Mine Stable Management.....	534
		Rational Sociology at Mines.....	193
		Ray, Ariz., New Electric Hoists at.....	250
		Rayon, Mineral District of.....	605
		Recommended Appropriations for Bureau of Mines.....	455
		Reddie, Roy, Durable Shaking Screen.....	676
		Reducing California Dredging Costs.....	678
		Reeder, E. C., Cast-Iron Water-Jacket.....	55
		Reef, A. J., Rope Sheave for Curves, 207—Tipple at Delagua Mine, Colorado.....	456
		Refining at Broken Hill, Australia.....	498
		Refining Base Bullion.....	423
		Refining, Electrolytic.....	361
		Relation of Forestry to Mining.....	120, 180
		Relieving Accumulations of Gas.....	409
		Remarkable Home-Made Mining Plant.....	421
		Remarkable Wire Rope.....	105
		Removal of Western Office.....	129
		Removing Moisture From Iron Ore.....	734
		Repair Bands, Quick Tape.....	416
		Repairing a Spur Wheel.....	615
		Repairing Broken Steel Tapes.....	278
		Reply Postage on Foreign Mails.....	731

INDEX

ix

	Page		Page
Report of Broken Hill South Silver Mining Co.	426	Scientific Coal Mining.....	162
Rescue and Aid Act, British.....	516	Screen, A Durable Shaking.....	676
Rescue and Aid Order, British.....	21	Screening Devices, Efficiency of Fine.....	685
Rescue Work, Motor Car for Mine.....	517	Selection of State Mine Inspectors.....	634
Respiration Apparatus, Artificial.....	661	Self-Appointed Fiduciaries of Mining.....	514
Revision of Mineral Land Laws.....	260	Self-Oiling Tail-Rope Roller.....	281
Revival of Gold Mining.....	65	Separators, Magnetic.....	749
Revolving Suffocated Miners.....	661	Settling Chamber for Smelter Fume.....	125
Revolution on Mining, Effect of Mexican.....	695	Shaft Bottom at Arenberg Mine.....	413
Reynolds, Sim and W. H., Scientific Coal Mine Management.....	459	Shaft Bottom, Tentative Plan of.....	208
Rhode Island Coal Co.....	11	Shaft Bottoms, Automatic Switch for.....	408
Rice, George Graham, Not Much But Some..	577	Shaft Bottoms, Track Arrangement for.....	336
Rice, George S., Bruceton, Pa., Explosion, 596—Watering Dust, 66—Watering Mines...	222	Shaft, Gate for Top of Coal Mine.....	598
Richards, Wm. J., Lake of the Woods Mining District	665	Shaft Gate, Strong Mine, Victor, Colo.....	233
Ricketts, A. H., Legal Interpretations of Technical Terms, 535 — Self-Appointed Fiduciaries of Mining.....	514	Shaft Pillars, Coal Mine.....	214
Roads, Boiler Ashes for Mine.....	648	Shaft Plumbing, Method of.....	594
Roasting of Galena, The Blast.....	607	Shaft Raising in Hard Rock.....	495
Roberts, Fred C., Block Caving and Substopping	674	Shaft Sinking by Cement Injection.....	502
Robison Mine, Supports of Feed Wires.....	166	Shaft Sinking by Electric Sinking Hoists..	624
Robinson, Neil, Profit and Loss Account.....	83	Shaft Sinking by the Poetsch Method.....	245
Rock Dump at Cokedale, Swinging.....	48	Shaft, Timbering a Small.....	743
Rock Dump, Cameron Mine.....	158	Shafts, Deep Coal Mine.....	598
Rockvale New Air Slope.....	653	Shafts for American Coal Mines.....	344
Rocky Mountain District, First-Aid Contests (1911)	201	Shale-Oil Enterprise in New Brunswick....	472
Roebling's Sons Co., Remarkable Wire Rope Rogler-Hoerbiger Valve, Advance in Air Compression, 339—Manufacturers of.....	458	Shares, Overproduction in Mine.....	449
Roller, Self-Oiling Tail-Rope.....	281	Sheave for Curves, Rope.....	207
Rolling Friction.....	33, 90	Sheffels, Bernard H., Not Much But Some..	577
Rolls, The Edison Crusher.....	299	Shot Firers, Early.....	159
Roof on Position of Timbers, Influence of..	703	Shot Firers, Watering Dust and Employment of.....	221
Roofs, Method of Supporting Mine.....	279	Shot Firers, Watering of Mines and Employment of.....	159
Rope as Applied to Mining, Wire.....	404	Shrager, A. L., Shaft Sinking by Cement Injection	502
Rope Hauls, Grade for.....	401, 472	Siberia, Gold Mining in.....	687
Rope Sheave for Curves.....	207	Silting in European Mines.....	715
Rope to Knuckle, Spiral for Raising.....	542	Silting Mine Workings, Flushing or (Origination)	321, 385
Rotary Tray Concentration.....	428	Silver and Gold Output, 1911.....	506
Roumania's Newest Oil Field.....	276	Silver Deposits, Genesis of.....	504
Rowland, R. H., Economy in the Use of Steam	470	Silver Deposits, Minerals Common to.....	438
Rubbing Surface of Airway, Correction.....	594	Silver Districts, Common Features of.....	296
Russia, Chilian Mills and Amalgamation.....	108	Silver Districts, Geological Structure of.....	358
Russia, Notes on Chilian Mills in.....	177	Silver Mining in Peru.....	360
Russian Mine Law, New.....	450	Silver Veins, Cobalt.....	61
Russian Platinum Production.....	632	Simcock, E. O., Coal Dust and Zone Systems	23, 85
SAFETY APPLIANCES, UNDERGROUND	155	Simmons, Jesse, Gold Mining Progress in South Dakota, 298—Homestake Employees' Aid Fund	555
Safety Blocks at Castle Gate Tipple.....	141	Sinking by Electric Sinking Hoists, Shaft..	624
Safety Chocks for Chain Hauls.....	73	Sintering Fine Iron Bearing Materials.....	559
Safety Demonstration, National Mine.....	69	Sintering Processes, Treatment of Broken Hill Ores	315
Safety Lamp, History of the.....	721	Siphon	350
Safety the First Consideration (H. C. Frick Coke Co.).....	5	Siphon and Pump Combined.....	431
Safety Through Systematic Timbering.....	195	Siphon, Capacity of.....	535
Saginaw Valley Mines, Michigan.....	148	Siphons	401
Saline County Coal Co., Mine No. 3.....	387	Sixteen Tons of High Explosive in a Blast Size of Motor to Drive Fan.....	660
Salt Deposit, Natural.....	238	Sizing Tests, Laboratory.....	125
Sampler, Mechanical Laboratory.....	139	Slag Into Fertilizer, Converting Basic.....	36
Sampling Drill Holes, Surveying and.....	167	Slate and Marble in Newfoundland.....	367
Sampling Free Milling Gold Ore, Difficulties in	659	Slicing at the Caspian Mine, Top.....	733
Sampling of Ores, Mechanical.....	735	Slime Pulp, Air-Lift Agitation of.....	239
San Bois Mine Explosion.....	587	Smelter Fume, Settling Chamber for.....	125
San Bois, Okla., Disaster, Comments on.....	576	Smelting Furnaces, Copper.....	186
Sanderson, H. H., The Giroux Mine Fire, 435—Use of Oxygen Helmet in High Temperatures	335	Smelting With Oil, Blast-Furnace.....	249
Sapphire Mines, American.....	103	Smelting With Oil, Method of.....	165
Saunders, W. L., Driving the Loetschberg Tunnel	37	Smith, Carson W., Mining Cost Chart.....	705
Savelberg Process.....	315	Smith Gas Pump.....	705
Sayre, Edward A., Cost of Mining Coal in Iowa	216	Smith, George Otis, Western Coal Land Legislation	277
Schofield, Wm. McN., Allowable Error in Closing Survey.....	472	Smith, J. A., Repairing Broken Steel Tapes..	278
Scholz, Carl, Panel System of Longwall.....	472	Smit, J. K., Brazilian Carbons.....	732
School in England, First Mining.....	414	Smoke by Combustion, Prevention of.....	584
Scientific Coal Mine Management.....	459	Smokeless Coal Fields of West Virginia....	467
		Snake Bite.....	41
		Soapstone, Uses of.....	41
		Society and Educational Notes, Mining.....	675
		Society Meetings.....	93
		Societies, Mining.....	605
		Sociology at Mines, Rational.....	193
		South Dakota, Gold Mining Progress in.....	298
		Spaerocobaltite	176
		Spahr, Jacob, Swinging Rock Dump.....	48
		Spain, Coal for.....	14
		Spain, Mining Industry of.....	90
		Spain, Tesorero Mine Tramway.....	571
		Spanish Iron-Ore Treatment Plant.....	237
		Specific Gravity Flask, The.....	489
		Specifications for Oil.....	594
		Spicer, H. N., Some Kalgoolie Hoisting Arrangements	572
		Spiral for Raising Rope to Knuckle.....	542
		Spontaneous Combustion of Coal.....	414
		Sprag at Radiant Mine, Iron.....	18
		Spring Valley Coal Co., Longwall Mining in Illinois	451
		Spur Wheel, Repairing a.....	615
		Square-Set Mining at Vulcan Mines.....	613
		Square Set, Proposed Modification of.....	302
		Stable Management, Mine.....	534
		Stadler, H., The "New Metallurgy," 739—The Specific Gravity Flask.....	489
		Stag Cañon Fuel Co., Waste-Heat Coke Ovens	142
		Standard Boiler House, A.....	255
		Standardization in Coal Washing.....	461, 536
		Standardization in Coal Washing, Correction	535
		Steam, An Effective Mine Air Humidifier..	531
		Steam, Economy in the Use of.....	470
		Steam Turbines at Mines, Exhaust.....	370
		Steamboat Camp, British Columbia.....	41
		Stearns, Ky., Coal Developments at.....	481
		Steel, A. A., Change House for Coal Miners, 647—Coal Mining in Arkansas, 9, 205—Gate for Top of Coal Mine Shaft, 598—Mine Explosion at McCurtain, Okla., 587—Overcasts With Light Walls, 515—Spiral for Raising Rope to Knuckle.....	542
		Steel Tapes, Repairing Broken.....	278
		Steel Mine Timbers in the Dodson Colliery	215
		Steins, N. Mex., Big Blast at.....	539
		Sterling, Paul, Correction, 90—Waterfall Chute	20
		Sterrett, Douglas B., Descriptive Mineralogy of Mica.....	625
		Stine Co., J. C., Centrifugal Mine Ventilators	223
		Stock Pile Fires.....	217
		Stone, J. C., Conduct of First-Aid Contests..	266
		Stope Model.....	491
		Stoppings to Withstand Explosions, Position of.....	535, 659, 703
		Storage, Deterioration of Coal in.....	475
		Story of a May Day.....	697
		Strata, Kenova-Quadrangle Coal.....	522
		Stratton's Independence, Milling at.....	319
		Stratton's Independence Mill.....	570
		Strike Situation, Colorado Lignite.....	595
		Strong Mine, Victor, Colo., Shaft Gate.....	233
		Students Societies Affiliated.....	520
		Substopping, Block Caving and.....	674
		Suits, The Two-Million-Dollar Trespass....	92
		Sultana Mine.....	665
		Supporting Mine Roofs, Method of.....	279
		Supports for Feed Wires.....	166
		Survey, Allowable Error in Closing.....	401, 472
		Survey Notes, Mine.....	213
		Surveying and Sampling Drill Holes.....	167
		Swimming Pools for Mining Towns.....	276
		Swinging Rock Dump at Cokedale.....	48
		Switch at Navajo Mine, New Mexico.....	664
		Switch for Shaft Bottoms, Automatic.....	408
		Sykesville, Pa., Disaster At.....	2, 84
		Symbols for Mine Maps, Electrical.....	473
		Systematic Tunnel Driving (Loetschberg)...	105
		TABLE, CANVAS	731
		Tale Imports, 1910.....	606
		Tale Industry, 1910.....	547
		Taft in the Homestake Mine, President.....	369
		Taggart, O. R., Atlantic City Mining District	730
		Tailing Disposal Device at Colburn Mill....	748
		Talisman Mine, N. Z., Mining Ore at.....	443
		Talk-O'-th'-Hill Colliery Coal Dust and Zone Systems	24
		Tam O'Shanter Ore, Milling the.....	492
		Tape Repair Bands, Quick.....	416
		Tapes, Repairing Broken Steel.....	278

	Page		Page		Page
Tarleton, C. H., Mine Explosions From Natural Gas Well.....	15	United Coal Co., Buckner No. 2 Mine.....	272	White, E. E., Surveying and Sampling Drill Holes	167
Taylor, S. A., Coal Mining Institute of America.....	28	United States Copper Production.....	610	Whiteside, F. W., Haulage System at Gray Creek Mine.....	264
Technical Education.....	514	United States Geological Survey, Topographic Map of United States.....	619	Wilkes-Barre Mining Institute Banquet.....	541
Technical Education, Fundamentals in, 550,	629, 688	Universal Mine Plant and Shafts.....	131	Willey, Day Allen, Coal Washing at Lahausage	391
Technical Terms, Legal Interpretations of.....	535	University of Illinois School of Mines.....	27	Williams, R. Y., Extinguishing the Majestic Mine Fire.....	342
Tennessee, Bauxite Mining in.....	419	Unwatering Tresavean Mine.....	566, 616	Wilson, E. B., Forest of Dean Mine, 184—History of Coal-Dust Explosions, 707—Notes on Pyrite and Marcasite, 127—Penn-Mary Coal Co. Plant.....	261
Tennessee Coal Production.....	18	Uruguay, Mining in.....	320	Wilson, Herbert, Fires in Metal Mines.....	253
Tennessee, Coker Creek Gold Field.....	547	Use of Candles in the Transvaal.....	742	Wire Rope as Applied to Mining.....	404
Tennessee, Lookout Mountain Coal Measures	654	Use of Oxygen Helmet in High Temperatures	335	Wire Rope, A Remarkable.....	105
Tennessee Phosphate Rock.....	621	Using Electric Power on a Steam Hoist.....	721	Wires, Supports for Feed.....	166
Tentative Plan of Shaft Bottom.....	208	Utah, Watering Dust in.....	159	Wittich, Lucius L., Following the Ore in Joplin Mines, 556—History of Kansas Oil Development, 384 —Hydraulicking With Waste Water, 118—Joplin District, 1911, 447 —Magnetic Separation of Ores, 46—Ore Mine Inspection in Missouri, 173—Petroleum in Oklahoma, 291—Treating Low-Grade Zinc Ore.....	115
Tesorero Mine Aerial Tramway.....	571	Utilizing Water in Mines.....	683	Woman Mine Worker, A.....	204
Test on Cyanide Ore, Laboratory.....	666	VALUATIONS, MICHIGAN MINE.....	130	Wooen-Stave Water Pipe.....	620
Tester, The Smith Gas Pump.....	705	Vanadium, Its Properties and Metallurgy	106	Woodson, C. C., Watering Dust and Employment of Shot Firers.....	221
Testing Gasoline Mine Locomotives.....	341	Variations of the Compass Needle.....	750	Woodson, E. F., Method of Shaft Plumbing..	594
Testing Miner's Oil, Method of.....	82	Veins, Leadville, Colo., Fissure.....	549	Woodward No. 3 Shaft.....	697
Tests for Oil Wanted.....	535	Ventilating Blind Chutes in Gaseous Mines	403	Woodworth, R. B., Steel Mine Timbers in Dodson Colliery.....	215
Tests, Laboratory Sizing.....	125	Ventilating Equipment, Efficiency of.....	460	Working Vertical Bituminous Coal Seam.....	703
Texas Oil Fields.....	623	Verner, John, Coal-Dust Explosions, 78—Lessons to Be Learned From Mine Fires, 19—Lessons to Be Learned From Recent Disasters	81	Workmen's Liability Insurance.....	412
Texas, Tin Deposits of El Paso County.....	111	Vertical Bituminous Coal Seam, Method of Working	594	World-Wide' Figures.....	123
Thompson, A. E., Practical Coal Haulage.....	650	Victor American Fuel Co., General Haulage of Coal, 200—Haulage System at Gray Creek Mine, 264—Instruction Car, 348—Iron Sprag at Radiant Mine.....	18	Wyoming, Atlantic City Mining District.....	730
Three Rails for Motor Gathering.....	701	Victor Electric Safety Lamp.....	79		
Tierney, Lawrence E., Effective Mine Air Humidifier	531	Virginia, Brown Hematite Mining in.....	553	YELLOW PINE DISTRICT, Zinc Mines of Southern Nevada.....	671
Timbering a Small Shaft.....	743	Vivian, James D., Time Keeping at Crystal Falls	241	Young, C. M., Coal-Dust Explosions and Air	350
Timbering, Proposed Modification of the Square Set	302	Voorspoed Diamond Mine, The.....	247		
Timbering, Safety Through Systematic.....	195	Vulcan Mines, Square-Set Mining at.....	613	ZINC CRUSTS AND DROSSES, TREATING	498
Timbers, Antiseptic Treatment of Mine.....	706	WANTED—COAL MINE MANAGERS.....	526	Zinc and Lead Notes.....	300
Timbers in Dodson Colliery, Steel.....	215	Ward, C. E., Oils for Lubrication.....	26	Zinc-Lead Production of Missouri, Kansas, and Oklahoma, 1911.....	433
Timbers, Influence of Roof on Position of...	703	Warriner, Samuel D.....	714	Zinc Mines, Joplin.....	556
Time Keeping at Crystal Falls.....	241	Washery at Saginaw, Mich., Consolidated Coal	468	Zinc Mines of Southern Nevada.....	671
Tin Alloys, Cerium.....	632	Wash House for Coal Miners.....	299	Zinc Mining in Missouri.....	386
Tin Mining in Federated Malay States....	374	Washing, Coal.....	660	Zinc Notes, Joplin.....	187
Tin, Occurrence of.....	746	Washing at Lahausage, Coal.....	391	Zinc Ores, Magnetic Separation.....	46
Tin Plate in Trade of the United States, 1911	96	Waste-Heat Coke Ovens (Stag Cañon Fuel Co.)	142	Zinc Ore, Treating Low-Grade.....	115
Tin Production of Bolivia, 1911.....	421	Waste Water, Hydraulicking With.....	118	Zone Systems, Coal Dust and.....	23, 85
Tintic District, Utah, Mining in the.....	375	Water Gauge Formula.....	18	Zulch, W. G., El Paso Shaft, Cripple Creek, Colo., 488—Stope Model, 491—Tailing Disposal Device at Colburn Mill.....	748
Tipple at Delagua Mine, Colorado.....	456	Water Gauge of Fan, Formula.....	87		
Tobin Mine, Block Caving and Substopping...	674	Water Gauge of Mine.....	536	Index B—Book Review	
To Decrease Anthracite Mine Accidents.....	636	Water Gauge, To Calculate.....	703	ANNALES DES MINES DE BELGIQUE, 1911	4
Tomkins Cove, The Edison Crusher Rolls..	299	Water Jacket, A Cast-Iron.....	55	Annual Report of Smithsonian Institution, 1910	480
Tooele, Utah, International Smelter at.....	56	Waterfall Chute	20	Applied Methods of Scientific Management..	586
Topographic Map of the United States.....	619	Watering Coal Dust.....	66	Appraisal of Mining Properties of Michigan	677
Topographical and Geological Mapping.....	312	Watering Dust and Employment of Shot Firers	221	Autobiography of John Fritz.....	479
Top Slicing at the Caspian Mine.....	733	Watering Dust in Utah.....	159		
Tourmaline Mine, American.....	103	Watering of Mines and Employment of Shot Firers, Early.....	159	BRITISH COLUMBIA, REPORT OF MINISTER OF MINES, 1910.....	144
Tourmaline Mine, Himalaya.....	181	Watering Mines.....	222	Building Stones and Clays.....	677
Track Arrangement for Shaft Bottoms.....	336	Water-Jacket, A Cast-Iron.....	55	Bureau of Labor Statistics, Springfield, Ill...	586
Traer, Glenn W., Antitrust Laws and the Coal Industry.....	644	Watson, Joseph, The Puritan Mine, 140—Como Mine No. 5.....	89	Bureau of Mines, Washington, Publications	3, 281, 541, 586, 677
Tramway, Tesorero Mine, Aerial.....	571	Watts, A. C., Watering Dust in Utah.....	159	Bureau of Science, Manila, Mineral Resources of the Philippine Islands, 1910, 4,	160, 677
Tray, Parting.....	670	Weathering of Coal Seams, The.....	257, 273	Business Correspondence Library.....	586
Treating Copper Anode Residues.....	622	Weldin, William Archie, Modern Steel Tipple at Annabelle Mines, 325—Quick Tape Repair Bands.....	416	Business Prospects Year Book for 1912.....	480
Treating Low-Grade Zinc Ore.....	115	Well, Mine Explosions From Natural Gas..	15		
Treating Zinc Crusts and Drosses.....	498	Wentworth, A. R., Capacity of Siphon.....	535	CALIFORNIA STATE MINING BUREAU, COUNTY MAPS AND MINING LAWS OF CALIFORNIA.....	160
Treatment of Broken Hill Ores...227, 315, 381,	498	Western Coal Land Legislation.....	277	Canada Department of Mines, Bulletin No. 5	160
Tresavean Mine, Unwatering.....	566, 616	Westinghouse Electric & Mfg. Co., 222—Machinery for Mining.....	66	Connecticut Geological and Natural Survey..	144
Trinidad, Oil in.....	256	West Virginia, Coal Geology of.....	12	Copper Handbook, 1910.....	352
Trinidad, Pitch Lake.....	300	West Virginia Coal Mining Institute.....	323, 460		
Tromp, An Ore Mine.....	185	West Virginia Disaster, The Jed.....	579		
Truesdale Breaker.....	657	West Virginia Mine Explosion, The Jed....	579		
Truesdale Shaft.....	698	West Virginia Mining Institute.....	29		
Tube Mill, The Giesecke.....	102	West Virginia, Production of Natural Gas...	294		
Tubes, Cutting and Bending Glass.....	429	West Virginia, Smokeless Coal Field of...	467		
Tucker, William, Rubbing Surface of Airway, Correction.....	594	Wethers, George J., Coal Washing.....	536		
Tungsten	48	What Brazil Offers Prospectors.....	235		
Tungsten Mining, Kern County, Cal.....	41	Wheel, Repairing a Spur.....	615		
Tunnel Driving, Systematic (Loetschberg)...37,	105				
Tunnel, Panther Creek Drainage.....	599				
Tupper, C. A., Ore and Coal Mining Machinery	454				
Turbine Mine Pumps.....	287				
Turbines at Mines, Exhaust Steam.....	370				
Turquoise Mine, American.....	103				
Two-Million-Dollar Trespass Suits.....	92				
Twentieth Century Cyanide Plant.....	35				
ULMER & CO., J. C., QUICK TAPE REPAIR BANDS.....	416				
Underground Safety Appliances.....	155				

D EPARTMENT OF AGRICULTURE PUBLICATIONS.....	Page 586
Department of Colonization, Mines and Fisheries, Quebec, Canada, Mineral Production.....	281, 540, 586
Department of Commerce and Labor Publications.....	281, 540, 677
Department of Lands, Forests and Mines, Ontario, Canada, Mining Accidents, 1911.....	586
Department of Mines, Geological Survey, New South Wales, 1910.....	281
Department of Mines, Ottawa, Canada.....	541
Department of Mines, Ottawa, Canada, Mineral Production, 1911.....	586
Design of Mine Structures.....	718
Dredges and Dredging.....	540
E LECTRICAL MINING INSTALLATIONS.....	352
G EOLGY OF MINERAL RESOURCES FREMONT COUNTY, WYOMING.....	541
Geological Survey of Alabama, Bulletin 10, Fayette Gas Field, Bulletin II, Roads and Road Materials.....	281
Geological Survey of New Jersey, Iron Mines and Mining in New Jersey.....	160
Geological Survey of Georgia.....	540
Geological Survey of Tennessee, Vols. 1, 2, 3, and 4, Resources of Tennessee.....	281
Good Engineering Literature.....	3
H EATON'S ANNUAL FOR 1912.....	479
I LLINOIS BUREAU OF LABOR STATISTICS, COAL REPORT, 1910.....	160
Inflammation of Gas Through Filaments of Electric Lamps.....	4
Interstate Commerce Commission Report, 1910 Iron Mines and Mining in New Jersey, Vol. 7, State Geological Report.....	677
L ABORATORY MANUAL FOR TESTING MATERIALS OF CONSTRUCTION.....	718
M ANUAL OF FIRE ASSAYING.....	677
Mechanical World's Pocketbook, 1912.....	352
Metallurgy of Tin.....	280
Michigan Geological Survey.....	540, 677
Mine Accidents and Their Prevention.....	480
Mineralogy.....	480
Mineral Industry, Vol. 19.....	224
Miners' Circular No. 5, Federal Bureau of Mines.....	352
Mining Law for the Prospector, Miner, and Engineer (MacFarren).....	224
Mining Laws of Alabama.....	4
Mining Laws of Wyoming.....	4
Mining Without Timber.....	410
Modern Assaying.....	480
Modern Practice in Fuel Contracts.....	410
N EW ZEALAND DEPARTMENT OF MINES, GEOLOGICAL SURVEY.....	677
North Carolina Geological Survey, Bulletins 20 and 23.....	586
North Carolina Geological Survey, Forest Fires and Their Prevention.....	281
Noticia dos Estudos E. Obras Contra os Efeitos da Secca.....	4
O BSERVATIONS ON THE WEST OF ENGLAND MINING REGION.....	586
Ohio Geological Survey, Bulletin No. 13.....	160
Oil Fields, Lambton County, Ontario.....	89
Oklahoma Geological Survey, Bulletin No. 8.....	540
Oregon Agricultural College.....	281
P APERS AND REPORTS RELATING TO MINERALS AND MINING IN NEW ZEALAND.....	677
Pennsylvania, Report of Department of Mines, Part II, Bituminous, 1910.....	160
Porcupine Series, Volume 1.....	4
Practical Geology and Mineralogy.....	280
Practice of Copper Smelting, The (Peters).....	224
Principles of Scientific Management.....	3

Q UELQUES MOTS SUR LE DEVELOPEMENT RECENT DU PROCEDE DE CREUSEMENT DES Puits PAR CONGELATION ET SUR LA SECURITE DANS LE FONCAGE DES Puits.....	Page 4
R ELATION BETWEEN TENSILE STRENGTH AND TRANSVERSE STRENGTH OF RAW CLAYS.....	4
Ricketts on Mines.....	411
Rock Minerals (Iddings).....	224
Report of Board of Directors of City Trusts, Philadelphia, 1910.....	4
Report of Bureau of Mines, Toronto, Canada, 1911.....	281
Report of Department of Geology and Natural Resources, Indiana, 1910.....	160
Report of Department of Public Works, Alberta, Canada, 1910.....	540
Report of Illinois State Mining Board, 1911.....	540
Report of Inspector of Coal Mines, Montana, 1909-10.....	4
Report of Inspector of Mines, Oklahoma, 1908-10.....	281
Report of Iron and Steel Institute, 1911.....	540
Report of Librarian of Congress, 1911.....	541
Report of Mine Inspector, New Mexico, 1910.....	4
Report of Mineral Resources and Production, Canada, 1909.....	82
Report of Mining Department of Tennessee, 1910.....	541
Report of Royal Commission, Iron and Steel Industry, New South Wales.....	677
Report of Secretary of Internal Affairs, Pennsylvania, 1910.....	540
Report of State Mine Inspector of South Dakota, 1911.....	540
Report of State Mine Inspectors of Wyoming, 1911.....	677
Report of Topographic Survey Commission, Pennsylvania, 1908-10.....	281
Report of Water Supply Commission of Pennsylvania, 1909.....	541
Report on Wirt, Roane, and Calhoun Counties, W. Va.....	352
Resources of Tennessee.....	352
S EARCHLIGHTS ON SOME AMERICAN INDUSTRIES.....	352
Shape Book, Carnegie Steel Co.....	280
South Wales Coal Annual, 1912.....	540
Stamp Milling.....	479
Study of the Blast Furnace (Harbison-Walker Refractories Co.).....	82
Subways and Tunnels of New York.....	719
T ECHNICAL ANALYSIS OF BRASS.....	280
Tennessee Geological Survey, Resources of Tennessee.....	4, 586
Textbook of Cyanide Practice.....	718
Types of Ore Deposits.....	480
U NITED STATES DEPARTMENT OF AGRICULTURE PUBLICATIONS.....	281, 540, 719
United States Geological Survey Publications.....	3, 160, 224, 280, 540, 677, 719
University of Illinois, Bulletin 53.....	586
University of Illinois, Tests of Suction Gas Producer.....	541
V ENTILATION OF MINES (RED-MAYNE).....	411
Verslag Van de Algemene Bestuurder Van Spoorwegen en Havens, 1910.....	541
Virginia Geological Survey.....	281, 586
W ALLS, BINS, AND GRAIN ELEVATORS.....	411
Washington Geological Survey.....	160, 540, 677
West Virginia Geological Survey.....	586
Wisconsin Geological and Natural History Survey, Bulletin 21.....	160
Z ONE SYSTEMS, COAL DUST AND.....	85

Index C—Personals and Obituaries	Page
A BELL, JOHN T.....	192
Adams, James M.....	323
Affelder, W. L.....	407, 494
Albert, Theodore (Obit.).....	719
Allen, M. C.....	577
American Institute of Mining Engineers, New Members.....	578
American Mining Congress, Delegates, Chicago, 1911.....	192
American Mining Congress, Spokane, Officers	696
Anderson, George G.....	408
Argall, Philip and P. H.....	259
Armstrong, L. K.....	696
Armstrong, Wm. H.....	219
Arnott, John.....	219
Atkinson, John Bond (Obit.).....	222
Aubury, Lewis E.....	323
B ACK, THOMAS.....	259
Ball, Will.....	696
Ball, Max W.....	494
Barbour, Percy E.....	119, 192
Barnard, Augustus P.....	407
Barnett, Walter W.....	578
Bauder, W. R.....	4
Baumgartner, M.....	192
Bendit, Louis.....	192
Benner, Raymond C.....	259
Berry, John W.....	541
Berry, Jr., Joseph T.....	219
Bignell, L. G. E.....	656
Blair, B. K.....	407
Blackburn, Ward.....	696
Blackburn, W. H.....	407
Blacker, George.....	407
Blackinton, George W.....	656
Blatchley, W. H.....	494
Bodfish, F. V.....	656
Booth, Charles.....	494
Booth, J. Virgil.....	494
Bowen, George W.....	260
Boyle, P. M.....	4
Brackenbury, Cyril.....	656
Brady, Harry S.....	260
Briggs, W. M.....	259
Brinsmade, R. B.....	119, 192, 494
Brooks, Alfred H.....	260
Brown, A. H.....	407
Brown, Norton H.....	578
Brown, Ralph D.....	192
Brush, George Jarvis (Obit.).....	520
Buckley, E. R.....	191, 259, (Obit.) 465
Burch, H. Kenyon.....	541
Burgess, J. A.....	219
Burris, A. L.....	696
Butters, Charles.....	494
Butler, Prof. G. M.....	656
C ALDWELL, JAMES N.....	696
Calloway, A. W.....	696
Cannon, Prof. George L.....	408
Carpenter, B. C.....	408
Carter, T. Lane.....	494
Cartlidge, Oscar.....	259
Carstarphen, F. C.....	656
Channing, J. Parke.....	4
Charlton, W. H.....	408
Chase, F. M.....	219
Chauvenet, Dr. Regis.....	696
Christ, H. K.....	407
Cirkel, Fritz.....	259
Clark, C. H.....	4
Clausen, S. J.....	577
Colby, Albert Ladd.....	407
Cole, A. A.....	494
Collbran, J. C.....	696
Collins, C. P.....	656
Collins, Edgar A.....	696
Collins, George E.....	408, 494
Colorado Scientific Society.....	408
Comstock, Theodore B.....	191
Conner, Eli T.....	696
Cooper, J. H.....	494

	Page		Page		Page
Corey, Wm. E.	578	Harvey, Thomas C.	192	Meller, H. B.	220
Corts, W. C.	407	Hawkins, E. N.	408	Merrill, Charles W.	494, 578
Coryell, John G.	323	Hawley, H. S.	407	Meyer, Edgar J. (Obit.)	652
Cottrell, F. G.	219	Hayes, Willard	260	Miller, D. G.	578
Cox, A. D.	656	Heffner, H. J.	696	Morgan, Thomas	259
Coxe, Edward H.	656	Henderson, C. W.	656	Moore, Charles J.	578
Crane, W. R.	696	Henderson, E. B.	323	Moore, L. D.	578
Crees, Henry W.	696	Henderson, Fred B.	323	Mudd, Seely W.	191
Cregan, John	407	Henderson, R. M.	407	Murray, W. J.	191, 219
Crocker, F. R.	259	Henderson, W. H.	323		
		Henrotin, Chas. H.	494	NEWBERRY, A. W.	656
DALZELL, JOHN	191	Henry, Eugene	323	Newton, Charles W.	4
Danford, Mark O.	259	Hermann, Edward L.	119	Nicholl, John S.	323
Davis, Robert C.	696	Herrres, Jr., Otto	577	Nickerson, W. G.	696
Davis, Walter W.	323	Hills, V. G.	656	Nelan, J. A.	192
Dawley, C. A.	696	Himes, J. E.	191	Noros, Joseph B.	4
DeCamp, Val.	577	Hodgson, Captain Joseph	696		
Delamater, George R.	219,	Hopewell, Col. W. S.	407	OBERN, D. W.	259
Delaney, Eugene A.	119	Hogue, O. D.	260	O'Brien, T. H.	119
Delegates, American Mining Congress, Octo- ber, 1911	192	Hoskin, A. J.	259	Of, Charles	408
Dinsmoor, W. P. J.	408,	Humphrey, J. H.	696	Osborne, Francis M. (Obit.)	18
D'Inwilliers, Edward V.	119	Humphreys, Dr. Alex. C.	323	Owens, C. C.	541
Dorr, J. V. N.	219	Huntton, Louis D.	192,		
Douglas, James	4	Huston, W. J.	260	PALMER, C. H.	407
Dowler, H. P.	323			Palmer, Leroy A.	192, 260
Dowling, Walford R.	541	INGALLS, WALTER R.	4,	Palmer, Richard (Obit.)	520
Downs, C. R.	656	Institution of Mining and Metallurgy	541	Parks, Prof. H. M.	541
Drake, Francis	578			Parmelee, H. C.	408, 696
Drury, W. M.	494	JAGER, O. E.	219	Parrish, J. C.	407
Dudley, Boyd	323	Jennings, W. P.	4	Pate, W. S.	407
Dudley, Jr., Boyd	119	Jessup, A. B.	656	Patten Coal Mining Co.	323
Duncan, W. E.	323	Jones, Charles Colcock	191	Payne, Dr. Henry M.	696
		Jones, Fred	578	Peabody, Francis S.	541
		Jones, William E.	407	Phillips, W. B.	323, 407
EASILY, CLAUDE	656	Johnson, J. J.	323	Phillips, S. J.	4
East, Jr., J. H.	494	Julian, H. Forbes (Obit.)	652	Pott, John N.	259
Ebbley, Norman	323			Potts, Frederic A.	192
Elliott, A. H.	656	KELLY, WM.	656	Poore, George	494
Elliott, W. R.	407	Kelso, D. C.	578	Price, E. P.	323
Engle, Frederick	696	Kemp, W. H.	4	Prytherch, H. O.	4
Evans, George Watkin	192, 219, 578,	Kilgour, Hamilton	494	Purdue, A. H.	577
Evans, John	407	Klockman, A.	4		
Everest, H. A.	578	Klodt, B. G.	260	QUINN, ROBERT A.	541
		Koon, Sidney G.	323		
FERNEKORN, F. E.	260	Kornuff, C. M.	656	RABB, JR., EDWARD M.	4
Finch, John A.	4	Kurtz, T. M.	323	Rambo, Wm. C. J.	656
Finlay, James R.	4, 119,			Ramsey, Charles S.	578
Finlayson, A. M.	541	LAKES, ARTIUR	494	Raymon, R. M.	494
Finley, Walter H.	4	Lakes, Jr., Arthur	219	Repath, Chas. H.	541
Fisher, Norman	494	Lathrop, William Arthur (Obit.)	585	Redpath & McGregor	578
Fitzgerald, James	696	Laughlin, S. W.	656	Reese, Jack	191
Fitzgerald, K. M.	323	Lawrence, B. B.	656	Rice, George S.	119
Fohs, F. Julius	494	Lawrence, Willis	696	Richards, John W.	408
Foster, R. Rodric	494	Leckie, William	656	Ricketts, Dr. L. D.	119
Fraenkel, Dr. Walter	323	Leyshon, T. A.	323	Riddle, Miss Rebecca	260
Fuller, Charles A.	192	Lewishon, Julius A.	696	Riker, C. M.	407
		Lindgren, Waldemar	219, 260,	Riter, George W.	259
GABLE, A. S.	577	Lincoln, F. C.	259	Robbins, Francis L. (Obit.)	151
Gates, William	541	Little, Arthur D.	494	Roberts, J. C.	192, 219
Gayton, S. R.	656	Livermore, Robert	494	Roberts, Major Jacob (Obit.)	652
Goodale, Stephen L.	119	Lloyd, W. Bert	191	Robertson, Wm. Fleet	219
Goodell, A. E.	259	Lobdell, Horace R.	119	Robertson, W. H.	407
Goodenough, G. A.	219	Loomis, W. H.	407	Robinson, Neil	696
Godwill, Philip	119	Ludlow, Edwin	494	Roesler, H. A.	119
Grady, W. H.	4			Rollestone, A. A.	696
Graham, James W.	408	McALLISTER, ROBERT	191,	Ropes & McIntire	259
Grant, James Benton (Obit.)	276	McAuliffe, Eugene	191	Rossbottom, Frank	259
Greenway, John C.	656	McCallum, Jean	578	Rossman, W. F.	407
Groves, Arthur	260	McCarthy, James F.	323		
Guess, George A.	494	McClaine, A. F.	323	SACKETT, BLAIR	696
Guggenheim, Benjamin (Obit.)	652	McDermott, Walter	541	Sanderson, H. H.	192, 219
Guterman, Franklin B.	192,	McDonald, James B.	696	Saunders, W. L.	656
		McGregor, A. G.	407	Schaeffer, T. X.	541
		McKinley, Jr., Edward S.	407	Schmidt, Sidney S.	192
HADESTY, GEORGE B.	119	McKnight Coal Co.	323	Schneider, Prof. G. W.	259, 323
Haff, E. L.	656	Mackie, R. G.	4	Sharp, J. R.	541
Hager, John F.	323	Maguire, John (Obit.)	520	Shelly, John F.	656
Halberstadt, Baird	4,	Manley, Bernard P.	407	Shields, Dr. M. J.	219
Haldane, Wm. G.	578	Marple, E. W. (Obit.)	18	Shillingford, Henry T.	407
Hall, W. J.	119	Marshall, A. A.	656	Shnck, J. J.	578
Hallett, A. F.	578	Marshall, E. M.	323	Shunway, E. E.	656
Hammond, John Hays	4	Martin, John C.	191	Simpson, R. H.	191
Hammond, Lyman P.	578	Mathewson, E. P.	541,	Sjostedt, Ernst A. (Obit.)	652
Haney, Marshall	408	May, Capt. W. A.	408	Smith, Sumner S.	4, 192, 219,
Hansen, G. T.	4	Meier, Col. E. D.	323	Smith, W. Gus	494
Harper, L. J.	407	Mein, W. W.	407	Snedaker, James A. (Obit.)	465
Harris, A. M.	656				

	Page		Page		Page	
Snellus, M.....	192	Ruckeye Engine Co.....	533	O HIO BRASS CO.....	52, 126	
Snyder, Jr., Baird.....	408	Buffalo Forge Co.....	222, 380	Oliver Continuous Filter Co.....	52	
Sowards, James.....	323	C ANTON FOUNDRY & MACHINE CO... 578			P ENNSYLVANIA CRUSHER CO..... 380	
Spicer, H. N.....	192, 259	Carnegie Steel Co.....	126, 311, 742	Power and Mining Machinery Co.....	126	
Spurr, J. E.....	696	Chain Belt Co.....	52	R OBERTS & SCHAEFER CO..... 222, 311		
Stevens, Horace J. (Obit.).....	653	Chalmers & Williams.....	222	Robbins Conveying Belt Co.....	311, 407, 533	
Stewart, W. B.....	323	Chicago Pneumatic Tool Co.....	311, 406, 533, 578, 742	Rockwell Co., W. S.....	578	
Storms, W. H.....	323	Clinton Wire Cloth Co.....	151	Roebbling's Sons Co., John A.....	407, 533, 742	
Storrs, A. H.....	656	Crocker-Wheeler Co.....	222	Roessler & Hasslacher Chemical Co.....	407	
Strohl, George F.....	577	Cross Engineering Co.....	533	S CHAEFFER & BUDENBERG MFG. CO..		
Summer, Charles.....	407	D AVENPORT LOCOMOTIVE WORKS.... 652			Seneca Camera Mfg. Co.....	52
Sutton, Wm. S.....	494	Davis & Son (Derby) Ltd., John.....	151	Servus Rescue Equipment Co.....	222, 126	
T ALMADGE, JAMES E..... 259						
Taylor, E. B.....	260	Deane Steam Pump Co.....	406, 652, 742	Shear-Klean Grate Co.....	742	
Taylor, V. M.....	323	De Laval Steam Turbine Co.....	222, 578	Smit & Zonen, J. K.....	222	
Taylor, William Washington.....	260, (Obit.) 465	De La Vergne Machine Co.....	222	Simons & Co., G. L.....	52	
Thane, B. L.....	323	Denver Engineering Works Co.....	578	Streeter-Amet Weighing & Recording Co.....	380	
Thomas, Kirby.....	494	Dupont de Nemours Powder Co., E. I., 222, 578	507, 742	Stromberg-Carlson Tel. Mfg. Co.....	52, 533, 742	
Tobey, Chas. H.....	407	E ASTERN MFG. CO..... 52			Sturtevant Mill Co.....	52, 578, 742
Tollman, Jr., C. F.....	696	Electric Service Supplies Co.....	380	Sullivan Machinery Co.....	52, 126, 652	
Townsend, Morgan T.....	192, 407	Electric Weighing Co.....	407	Sylvester Co.....	742	
Tracy, W. T.....	323	F ERRO MACHINE & FOUNDRY CO..... 506			T AYLOR IRON & STEEL CO. 380, 742	
Traer, G. W.....	541	Furnace Gas Consumer Co.....	652	Toledo Pipe Threading Machine Co.....	652	
Turner, H. W.....	494	G ARDNER CRUSHER CO..... 52, 151			Trenton Iron Co.....	126, 380
Turner, J. K.....	656	Gardner Governor Co.....	151, 578	Trill Indicator Co.....	742	
Turner, James M. (Obit.).....	719	General Electric Co.....	52, 126, 151, 222, 311, 380, 407, 506, 533, 578, 652, 742	U EHLING INSTRUMENT CO..... 652		
Turner, N. P.....	578	General Fire Extinguisher Co.....	506	Union Iron Works Co.....	506	
Turman, B. D.....	323	Goulds Mfg. Co.....	52, 126, 151, 380, 533, 406, 652, 742	V ULCANITE PORTLAND CEMENT CO..		
Tyrell, J. B.....	192, 408, 656	H ARBISON-WALKER REFRACTORIES CO. 533			Wagner Electric Mfg. Co.....	742
V ALLAT, BENJAMIN W..... 259						
Vandergrift, J. B.....	408	Hardy Patent Pick Co., Ltd.....	652	Watt Mining Car Wheel Co.....	222, 407	
Van Winkle, Charles T.....	192	Harris Air Pump Co.....	151	Weber Subterranean Pump Co.....	151	
Vivian, Col. G. G.....	656	Hayton Pump Co.....	151	Western Machinery & Mfg. Co.....	52	
W ANJAKOW, Dr. W..... 323						
Warfel, C. Guy.....	494	Hazard Mfg. Co.....	52, 742	Westinghouse Electric & Mfg. Co.....	222	
Warwick, A. W.....	192	Hendrie & Bolthoff Mfg. & Supply Co., 222, 533	533	Wheeler Condenser & Engineering Co., 222, 311	742	
Weed & Probert.....	656	Hess Flume Co.....	380	Williams, F. M.....	742	
Wellman, S. T.....	494	Homestead Valve Co.....	52	Williamsport Wire Rope Co.....	52	
Weston, William.....	259	Hooven, Owens, Rentschler Co.....	652	Wirt Electric Specialty Co.....	652	
Wetherill, William C. (Obit.).....	466	Howells Mining Drill Co.....	506	Worthington, Henry R.....	52	
White, H. C.....	192	Hoynes Safety Powder Co.....	578	Wyckoff, A.....	533	
White, Rush J.....	119	Hughson Steam Specialty Co.....	222	Y ORK BRIDGE CO..... 407		
Whitehurst, J. W.....	577	Hull Mfg. Co.....	52	Z IERMORE REGULATOR CO..... 506		
Wick, George D. (Obit.).....	652	Hyatt Roller Bearing Co.....	652, 742	I NGERSOLL-RAND CO..... 311, 380, 407, 506, 533, 578, 652, 742		
Wiley, W. H.....	191	J EFFREY MFG. CO 311, 380			A CKROYD & BEST, LTD 22	
Wilson, Eugene B.....	541	Jenkins Bros.....	652	Allis-Chalmers Co.....	22	
Wilson, E. H.....	259	Johns-Manville Co., H. W.....	380	American Blower Co.....	22, 110, 276, 692	
Wilson, Francis Church.....	192	Johnson, J. M. & O. R.....	380	American Mining Congress, Exhibits at.....	275	
Wilson, Philip D.....	494	Johnson & Johnson.....	380	American Rubberfelt Co.....	275, 593	
Wise, W. B.....	407	K EELER CO., E..... 52			American Safety Lamp & Mine Supply Co... 276	
Wolcott, E. L.....	260	Keystone Driller Co.....	506, 578	Austin Separator Co.....	593	
Wolf, Alfred G.....	577	Koppers, H.....	578	B ARTLETT & SNOW CO., C. O..... 529		
Woodward, H. W.....	4	Kueffel & Esser Co.....	380	C ARD IRON WORKS CO., C. S., RE-MOVAL 22		
Y ORK COAL & COKE CO..... 323						
Young, Horace G.....	407	L AGONDA MFG. CO..... 742			Carnegie Steel Co.....	110
Young, R. J.....	407	Lea Equipment Co.....	533	Chicago Pneumatic Tool Co.....	110, 275	
Z ABRISKIE, CHARLES..... 696						
Zern, E. N.....	219	Linde Air Products Co.....	52	Christy Box-Car Loader Co.....	22	
I NDICES						
Index D—Catalogs Received						
A CKROYD & BEST, LTD..... 52						
Aldrich Pump Department.....	52, 406, 407	Link-Belt Co.....	742	D AVIS & SON (DERBY) LTD., JOHN 529, 593		
Allis-Chalmers Co.....	151, 222, 311, 380, 406, 506, 533, 742	Litchfield Foundry & Machine Co.....	222	DeLaval Steam Turbine Co.....	212	
American Blower Co.....	126, 406, 742	Luitwieler Pumping Engine Co.....	52	Dixon Crucible Co., Joseph.....	529	
American Concentrator Co.....	533	Lunkenheimer Co.....	742	E LECTRIC SERVICE SUPPLIES CO..... 338		
American Moistening Co.....	222	M CKIERNAN-TERRY DRILL CO..... 52, 151, 222, 533, 742			G ANDY BELTING CO..... 145	
American Pulverizer Co.....	52	Mansfield & Co., W.....	222	Gardner Governor Co.....	592	
American Spiral Pipe Works.....	151	Mesta Machine Co.....	222, 52	General Electric Co.....	145, 692	
Amsler, Walter O.....	533	Monarch Engineering & Mfg. Co.....	52	Goodman Mfg. Co.....	110	
Atlas Engine Works.....	151, 506	Myers-Whaley Co.....	652	N ATIONAL ELECTRIC LAMP ASSOCIATION 311, 533, 578, 652		
B ABCOCK & WILCOX CO..... 52						
Baldwin Locomotive Works.....	52, 406, 407	Newhall Engineering Co., George M.....	151	Nicholson & Co., W. H.....	533	
Barco Brass & Joint Co.....	533	Niles-Bement Pond Co.....	151	O HLER & SONS CO..... 52, 126, 506		
Bartlett & Snow Co., C. O.....	311	P ENNSYLVANIA CRUSHER CO..... 380			Power and Mining Machinery Co.....	126
Best Mfg. Co.....	506	R OBERTS & SCHAEFER CO..... 222, 311			Robbins Conveying Belt Co.....	311, 407, 533
Bristol Co., The.....	126, 506	C HAIN BELT CO..... 52			Rockwell Co., W. S.....	578
Browning Engineering Co.....	126	C HALMERS & WILLIAMS..... 222			Roebbling's Sons Co., John A.....	407, 533, 742
Bowser & Co., S. F.....	652	C HICAGO PNEUMATIC TOOL CO..... 311, 406, 533, 578, 742			Roessler & Hasslacher Chemical Co.....	407
B ARTLETT & SNOW CO., C. O..... 311						
B EST MFG. CO..... 506						
B RISTOL CO., THE..... 126, 506						
B ROWNING ENGINEERING CO..... 126						
B OWSER & CO., S. F..... 652						
B UCKEYE ENGINE CO..... 533						
B UFFALO FORGE CO..... 222, 380						
C ANTON FOUNDRY & MACHINE CO... 578						
Carnegie Steel Co..... 126, 311, 742						
Chain Belt Co..... 52						
Chalmers & Williams..... 222						
Chicago Pneumatic Tool Co..... 311, 406, 533, 578, 742						
Clinton Wire Cloth Co..... 151						
Crocker-Wheeler Co..... 222						
Cross Engineering Co..... 533						
D AVENPORT LOCOMOTIVE WORKS.... 652						
Davis & Son (Derby) Ltd., John..... 151						
Deane Steam Pump Co..... 406, 652, 742						
De Laval Steam Turbine Co..... 222, 578						
De La Vergne Machine Co..... 222						
Denver Engineering Works Co..... 578						
Dupont de Nemours Powder Co., E. I., 222, 578						
E ASTERN MFG. CO..... 52						
Electric Service Supplies Co..... 380						
Electric Weighing Co..... 407						
F ERRO MACHINE & FOUNDRY CO..... 506						
Furnace Gas Consumer Co..... 652						
G ARDNER CRUSHER CO..... 52, 151						
Gardner Governor Co..... 151, 578						
General Electric Co..... 52, 126, 151, 222, 311, 380, 407, 506, 533, 578, 652, 742						
General Fire Extinguisher Co..... 506						
Goulds Mfg. Co..... 52, 126, 151, 380, 533, 406, 652, 742						
H ARBISON-WALKER REFRACTORIES CO. 533						
Hardy Patent Pick Co., Ltd..... 652						
Harris Air Pump Co..... 151						
Hayton Pump Co..... 151						
Hazard Mfg. Co..... 52, 742						
Hendrie & Bolthoff Mfg. & Supply Co., 222, 533						
Hess Flume Co..... 380						
Homestead Valve Co..... 52						
Hooven, Owens, Rentschler Co..... 652						
Howells Mining Drill Co..... 506						
Hoynes Safety Powder Co..... 578						
Hughson Steam Specialty Co..... 222						
Hull Mfg. Co..... 52						
Hyatt Roller Bearing Co..... 652, 742						
I NGERSOLL-RAND CO..... 311, 380, 407, 506, 533, 578, 652, 742						
Industrial Instrument Co..... 506, 578, 652						
J EFFREY MFG. CO 311, 380						
Jenkins Bros..... 652						
Johns-Manville Co., H. W..... 380						
Johnson, J. M. & O. R..... 380						
Johnson & Johnson..... 380						
K EELER CO., E..... 52						
Keystone Driller Co..... 506, 578						
Koppers, H..... 578						
Kueffel & Esser Co..... 380						
L AGONDA MFG. CO..... 742						
Lea Equipment Co..... 533						
Linde Air Products Co..... 52						
Link-Belt Co..... 742						
Litchfield Foundry & Machine Co..... 222						
Luitwieler Pumping Engine Co..... 52						
Lunkenheimer Co..... 742						
M CKIERNAN-TERRY DRILL CO..... 52, 151, 222, 533, 742						
Mansfield & Co., W..... 222						
Mesta Machine Co..... 222, 52						
Monarch Engineering & Mfg. Co..... 52						
Myers-Whaley Co..... 652						
N ATIONAL ELECTRIC LAMP ASSOCIATION 311, 533, 578, 652						
Newhall Engineering Co., George M..... 151						
Nicholson & Co., W. H..... 533						
Niles-Bement Pond Co..... 151						
O HIO BRASS CO..... 52, 126						
Oliver Continuous Filter Co..... 52						
P ENNSYLVANIA CRUSHER CO..... 380						
Power and Mining Machinery Co..... 126						
R OBERTS & SCHAEFER CO..... 222, 311						
Robbins Conveying Belt Co..... 311, 407, 533						
Rockwell Co., W. S..... 578						
Roebbling's Sons Co., John A..... 407, 533, 742						
Roessler & Hasslacher Chemical Co..... 407						
S CHAEFFER & BUDENBERG MFG. CO..						
Seneca Camera Mfg. Co..... 407, 506						
Seneca Camera Mfg. Co..... 52						
Servus Rescue Equipment Co..... 222, 126						
Shear-Klean Grate Co..... 742						
Smit & Zonen, J. K..... 222						
Simons & Co., G. L..... 52						
Streeter-Amet Weighing & Recording Co..... 380						
Stromberg-Carlson Tel. Mfg. Co..... 52, 533, 742						
Sturtevant Mill Co..... 52, 578, 742						
Sullivan Machinery Co..... 52, 126, 652						
Sylvester Co..... 742						
T AYLOR IRON & STEEL CO. 380, 742						
Toledo Pipe Threading Machine Co..... 652						
Trenton Iron Co..... 126, 380						
Trill Indicator Co..... 742						
U EHLING INSTRUMENT CO..... 652						
Union Iron Works Co..... 506						
V ULCANITE PORTLAND CEMENT CO..						
Wagner Electric Mfg. Co..... 742						
Watt Mining Car Wheel Co..... 222, 407						
Weber Subterranean Pump Co..... 151						
Western Machinery & Mfg. Co..... 52						
Westinghouse Electric & Mfg. Co..... 222						
Wheeler Condenser & Engineering Co., 222, 311						
Williams, F. M..... 742						
Williamsport Wire Rope Co..... 52						
Wirt Electric Specialty Co..... 652						
Worthington, Henry R..... 52						
Wyckoff, A..... 533						
Y ORK BRIDGE CO..... 407						
Z IERMORE REGULATOR CO..... 506						

INDEX

	Page		Page		Page
Goulds Mfg. Co.	110, 212, 458	Mining Safety Device Co.	145	S AMSON MFG. CO.	592
Green Fuel Economizer Co.	276	Missawaka Woolen Mfg. Co.	211	Schaeffer & Budenberg Mfg. Co.	458
H ARRIS AIR PUMP CO.	734	Mulecrooy Co.	22	Scranton Acetylene Lamp Co.	529
Hazard Mfg. Co.	22, 212	Murray Specialty Mfg. Co.	593	Servus Rescue Equipment Co.	724
Hockensmith Wheel & Mine Car Co.	213	N ICHOLSON CO., W. H.	338	South African Mining Journal	212
Hyatt Roller Bearing Co.	338, 692, 734	338	Standard Wood Pipe Co.	724
I NGERSOLL-RAND CO.	392	O HIO BRASS CO.	22, 593	Stine Co., J. C.	392
.....	392	Oklahoma State School of Mines Laboratory	22	Stope Drill Contest	212
J EFFREY MFG. CO.	145, 275, 338	Ottumwa Iron Works	392	Sullivan Machinery Co.	110
Johns-Manville Co., H. W.	110, 212, 458, 692	P ENNSYLVANIA STORAGE BATTERY CO.	528, 593	T RENTON IRON CO.	338, 392
Johnson & Johnson	212, 275	528, 593	Taylor Iron & Steel Co.	593
L INK-BELT CO.	458	Pilley Electric Lamp	145	U NION IRON WORKS CO.	22
Litchfield Foundry & Machine Co.	392	Porter Co., H. K.	338	22
Lord Co., George W.	529	R ICKARD & SLOAN	593	W ATT MINING CAR WHEEL CO.	458, 529
Lunkenheimer Co.	145, 392, 528, 529, 734	Ricketts & Banks	692	Way's Pocket Smelter Co.	212, 338, 593
Ludlow-Saylor Wire Co.	392	Ridgway Dynamo & Engine Co.	392	Western Electric Co.	110, 145, 392
M CKIERNAN-TERRY DRILL CO.	145, 212	Risdon Iron Works	22	Whitcomb Co., George D.	392
Maple City Mfg. Co.	212	Roberts & Schaefer Co.	22, 212, 275, 592, 692	Williams & Co., J. H.	692
Metallie Flexible Tubing Co.	22	Robinson, J. R.	211	Winslow Government Standard Scale Works	110
Milwaukee Locomotive Mfg. Co.	276	Rogler-Hoerbiger Valve	458	Wright Mfg. Co.	593

Mines *and* Minerals

Vol. XXXII—No. 1.

SCRANTON, PA.—AUGUST, 1911—DENVER, COLO.

Price, 25 Cents

PUBLISHED MONTHLY AT SCRANTON, PA.

ESTABLISHED 1881

WESTERN EDITORIAL OFFICE: 728 Equitable Building, Denver, Colo.
CHICAGO OFFICE: 1006 Michigan Ave.

Entered at the Post Office at Scranton, Pa., as second-class matter.

Address all business communications to MINES AND MINERALS, Scranton, Pa.
CABLE ADDRESS, "RETSOP, SCRANTON"

LONDON OFFICE: INTERNATIONAL BUILDINGS, KINGSWAY, LONDON, W. C.
SOUTH AFRICAN OFFICE: MANSION HOUSE CHAMBERS, ADDERLEY STREET, CAPE TOWN.

NEW ZEALAND OFFICE: 63 DIXON STREET, WELLINGTON.
AUSTRALIAN OFFICE: 83 PITT STREET, SIDNEY.

SUBSCRIPTION RATES

Single Copies.....	25 cents
Yearly Subscriptions, including postage:	
To United States, Mexico, Cuba, Porto Rico, Hawaii, and Philippines.	\$2.00
To Canada.....	2.50
To all other countries.....	3.00

The date after your name on the wrapper is that of the month to which your subscription has been paid. If you do not want to continue your subscription after that time, kindly notify us.

Notice to discontinue or change of address should be sent to the Scranton office.

When notifying us of a change of address always give your FORMER as well as your present.

Foreword

WITH this issue, No. 1 of Vol. XXXII, we inaugurate some improvements in MINES AND MINERALS, which have been in contemplation for some time. The principal changes are in appearance and the more convenient arrangement of the text. Plans have been made to ensure during the coming year the publication of mining literature that will be of even greater interest and value to our readers than the excellent material furnished in the past.

As will be noticed, the journal is divided into two sections of 30 pages each, one being devoted to the mining and preparation of coal and the other to ore mining and metallurgy.

As there is no monopoly of brains and skill in either the coal mining, ore mining, or metallurgical branches of the industry, a mining journal to be of real value must furnish accurate and well illustrated articles depicting the best methods evolved in each, so that its readers may not only learn what their colleagues in their special branches of industry are doing to reduce cost, increase production, or enhance safety, but they may also learn what new labor-saving and safety devices have been worked out by the able men in the other branches.

The editorial policy, as in the past, will be for the best interests of the mining industry regardless of what faction or party it hits. It will always remain a mining journal for mining men.

采采

The Decision on the Cunningham Claims

IN our issue of June, 1910, we treated at length in an editorial on the status of the Cunningham, Alaska coal land claims, and we have seen no reason to modify the views then expressed.

The decision of Commissioner Dennett of the General Land Office, approved by Secretary Fisher declaring the claims illegal may have the preponderance of law in its favor, but law is not always justice nor is it always practicable.

The Cunningham claimants were reputable men who invested their money in the Alaska coal lands and in an open and above-board manner endeavored to secure patents from the Government on lines that were generally followed, and in as close conformity to the then existing laws as possible. A merely tentative proposal made by a few of the claimants to a representative of the Guggenheims, not binding on either party, and in fact not really authorized by the majority of the claimants, and not given much consideration by the Guggenheims, was used to influence public opinion against the

TABLE OF CONTENTS

EDITORIAL—	
Foreword—Decision on the Cunningham Claims—The Disaster at Sykesville, Pa.....	1
OUR COVER PICTURE.....	2
BOOK REVIEW.....	3
PERSONALS.....	4
COAL MINING AND PREPARATION	
"SAFETY THE FIRST CONSIDERATION," by Stephen L. Goodale.....	5
INTERNAL COMBUSTION ENGINES IN MINES.....	8
COAL MINING IN ARKANSAS, by A. A. Steel.....	9
COAL GEOLOGY OF WEST VIRGINIA.....	12
MINE EXPLOSIONS FROM NATURAL GAS WELL, by C. H. Tarleton.....	15
TENNESSEE COAL PRODUCTION.....	18
APPOINTMENT OF OHIO MINE INSPECTORS.....	18
OBITUARY—	
Francis M. Osborne—E. W. Marple.....	18
IRON SPRAG AT RADIANT MINE.....	19
LESSONS TO BE LEARNED FROM MINE FIRES, by John Verner.....	20
THE WATERFALL CHUTE, by Paul Sterling.....	21
BRITISH RESCUE AND AID ORDER.....	21
TRADE NOTICES.....	22
COAL DUST AND ZONE SYSTEMS, by E. O. Simock.....	23
OILS FOR LUBRICATION, by C. E. Ward.....	26
COAL MINING NOTES.....	27
COAL MINING INSTITUTE OF AMERICA.....	28
WEST VIRGINIA MINING INSTITUTE.....	27
MINE INSPECTORS' ANNUAL MEETING.....	30
EXAMINATION QUESTIONS—	
Pennsylvania Anthracite Mine Inspectors, Scranton, May, 1911.....	31
CORRESPONDENCE—	
Rolling Friction—Filter Presses.....	33
AN OUTLINE OF MINING, by Will H. Coghill.....	34
ORE MINING AND METALLURGY	
A TWENTIETH CENTURY CYANIDE PLANT, by Chas. E. Christensen.....	35
DRIVING THE LOETSCHBERG TUNNEL, by W. L. Saunders.....	37
ORE MINING NOTES.....	40
THE CRANBERRY IRON ORE MINE, by J. N. Cameron.....	42
DIAGONAL-PLANE CONCENTRATING TABLE, by S. Arthur Krom.....	44
THE MAGNETIC SEPARATION OF ORES, by Lucius L. Wittich.....	46
SWINGING ROCK DUMP AT COKEDALE.....	48
MAKING GASOLINE FROM OIL WELL GAS, by F. W. Brady.....	49
CATALOGS RECEIVED.....	52
EQUIPMENT OF THE POVERTY GULCH MINE, by Chas. W. Henderson.....	53
A CAST-IRON WATER JACKET, by E. C. Reeder.....	55
INTERNATIONAL SMELTER AT TOOELE, UTAH, by Leroy A. Palmer.....	56
SOCIETY MEETINGS.....	59
GOLD DREDGING IN FOREIGN COUNTRIES.....	60
COBALT SILVER VEINS.....	61
NATIONAL FIRST-AID FIELD DAY.....	61
THE ELY MINING DISTRICT, NEVADA, by Percy E. Barbour.....	62
THE POST OFFICE AFTER MINE FRAUDS.....	64
SQUIBS—	
Anthracite Record Broken, 8—Kanite Explosives, 11—Coal for Spain, 14—Water Gauge, 18—Lake Superior Mining Institute, 27—Kentucky College of Mines and Metallurgy, 27—Manganese in South Africa, 33—Converting Basic Slag Into Fertilizer, 36—Chute Hook at Radiant Mine, 41—Tungsten, 48—Nova Scotia Oil Fields, 52—Gypsum in Nova Scotia.....	64

claimants. Even if the tentative proposal mentioned had been an actual one on the part of all the claimants, and it had been accepted by the Guggenheims, it would not have resulted in a monopolistic ownership of the Alaska coal lands, as the total acreage involved constituted but a small proportion of the whole. Besides, the Guggenheim interests, while powerful from the standpoint of business accomplishment, were unjustly and unfairly held up as enemies of the people and therefore enemies of the government.

That the claimants joined in the expense of driving a tunnel to determine the mineral value of the land in question was a rational and logical act on the part of men, the most of whom were more or less familiar with mining practice. That they might also later combine their holdings in a partnership in the shape of a corporation would also have been a rational act. Every man familiar with coal mining knows that in many cases a single holding of 160 acres of coal land cannot be profitably worked, but that 5,000 acres can be so developed and worked, through the medium of large plants and the use of appliances and methods that would be prohibitory in smaller areas, and that the coal could not only be profitably worked, but a larger percentage of the coal in the seams could be taken and marketed. This, making the largest percentage of the coal in the ground available for use, to the practical mining man means true conservation. Coal wasted by improper or crude mining methods is just as much wasted as if it was deliberately set on fire and burned without its destruction having served any useful purpose.

If the letter of the law when strictly interpreted and applied prevents any citizen or group of citizens from acquiring sufficient acreage of Government lands, for legitimate mining of coal, to warrant the profitable investment of sufficient capital to conduct mining operations in the safest and most economic manner, the law cannot be too quickly changed; or else some legislation should be quickly enacted whereby sufficiently large acreages of coal land may be leased on reasonable terms to individuals or corporations so as to warrant the expenditure of the required capital to develop and work them. Otherwise, the coal lands of Alaska will lie dormant for many years and the navy department and the citizens of the Pacific Slope will continue to use inferior fuel or pay exceedingly high prices for coal mined in foreign fields or east of the Rockies. Secretary Fisher himself, in commenting on this matter said: "I do not believe the present laws applicable to coal lands in Alaska are wise or practical laws."

柔 柔

JUDGING from C. H. Tarleton's paper on "Mine Explosions From Natural Gas Well," printed in another column, simply leaving a square coal pillar about a gas-well hole will not always prevent natural gas finding its way into coal mines. In one case the well was 2,300 feet distant from where the explosion

occurred. In order to prevent the flow of gas into the mines, recourse was had to "bleeding," and it may be probable that this will be found the only sure remedy in other cases; at any rate there is abundant evidence that once the gas sands are penetrated, gas under pressure will follow joints and cracks in strata a long distance.

柔 柔

The Disaster at Sykesville, Pa.

THE press dispatches announce that 21 men were killed at the Cascade Coal and Coke Co.'s mine, at Sykesville, near Dubois, Pa., on Saturday evening, the 15th ult. The early reports state that a comparatively light explosion of gas had evidently occurred, as none of the bodies were mutilated and but few showed burns. The supposition is that the after-damp, or carbon monoxide, was the cause of the death of the men. The mine was known as a non-gaseous mine, and the fire boss claims that he examined the heading where the explosion occurred an hour before and found no trace of gas.

The term non-gaseous mine is in our opinion directly responsible for numerous fatalities in coal mines, as it gives the employes a false sense of safety and is apt to result in more or less carelessness on the part of the workingmen and subordinate officials. This statement as to carelessness is made in a general way, and may not be applicable in this case, as due care may have been exercised. In our next issue, we will give a statement of the actual causes leading up to the accident as developed by the official inquiry which will be made by competent mining men. Until the results of such inquiry are known it is useless to conjecture, and frequently mischievous as well.

柔 柔

Our Cover Picture

The Lehigh Valley Coal Co.'s Mineral Spring breaker, at Parsons, near Wilkes-Barre, Pa., shown on our front cover is remarkable in the fact that practically all improved methods and appliances in the economical handling and preparation of anthracite coal have been embodied in its construction. Its capacity is 1,500 tons per day, and but 32 men are employed in and about the breaker, as against 72 employed in the old breaker which it replaced. In addition, the new breaker prepares and cleans the coal in a more efficient manner with very much less loss from breakage. All the machinery, chutes, jigs, screens, and conveyers are so arranged as to automatically handle the coal, and each part is so designed as to supply the coal in various stages of preparation to the succeeding stage or final bin, in carefully calculated quantities, and with practically no breakage other than that caused by the rolls. The various bins are arranged so that the lips of the chutes deliver the prepared coal on a belt conveyer, which in turn delivers it to the railroad cars. The delivery of the various sizes to the loading belt is accomplished by one man who controls the flow from any desired bin, by a series of levers. As will be seen in the illustration, the breaker structure is very substantial and compact. Its interior arrangement, as to light, ventilation, and roomy safe passageways and steps, is a model one. While most of the improvements used in this breaker have been in use for some

time in other breakers, this is the first instance in which all have been used in one breaker. The entire plant was designed by Mr. Paul Sterling, Mechanical Engineer of the Lehigh Valley Coal Co., assisted by suggestions from Mr. A. B. Jessup, Chief Mining Engineer, under the personal supervision of Mr. S. D. Warriner, Vice-President and General Manager.

來 來

Book Review

"GOOD ENGINEERING LITERATURE" is the title of a book by Harwood Frost, formerly editor of the *Engineering Digest*, sales agent, Chicago Book Co., 226 South La Salle Street, Chicago, Ill. The subject of this book is one of growing importance to both the practicing engineer and the student of engineering, and the author has endeavored to bring together information that may serve as a guide for technical men who may have aspirations toward literary success. The book contains 420 pages, is cloth bound, and is 5 in. x 7½ in. The price has been kept at the low figure of \$1 in order that its purchase may be no hardship to the beginner of professional life. Every engineer is sooner or later called upon to do some form of literary work, such as the preparation of reports, specifications, and contracts; the writing of descriptive papers for technical societies and periodicals, the discussion of engineering problems with committees, boards of directors, and public gatherings composed of men with little or no technical knowledge. In the course of some professional duties as well as in ordinary correspondence and conversation the engineer will find that the ability to speak and write clearly and forcibly, to express his thoughts and understandings, and to describe his works so that others will understand him, will prove one of the most valuable items in his mental equipment.

The book is divided into 22 chapters and is furnished with an index. Chapter I is on Literary Expression; Chapter II is on Rhetoric and Grammar; Chapter III deals with Orthography and Punctuation; Chapter IV treats on Words and Phrases; Chapter V has Inspiration and Motive in Literary Work as a subject; Chapter VI shows the essentials to success in literature; Chapter VII tells what to write about; Chapter VIII advises on the collection and arrangement of material; Chapter IX is on Exercising the Memory; Chapter X explains the preparation of manuscript; Chapter XI covers the field and policy of technical journals; Chapter XII shows how to write up articles; Chapter XIII is on the rights of an author in his works; Chapter XIV, Copyright; Chapter XV, Relations Between Author and Publisher; Chapter XVI, The Law of Libel; Chapter XVII, Preparation of Illustrations for Reproduction; Chapter XVIII, The Making of a Book; Chapter XIX, Indexing and Filing; Chapter XX, Literary Criticism; Chapter XXI, The Engineer's Library; Chapter XXII, List of Technical Indexes Appearing Serially.

This book will be found good reading, as it contains much information which men are apt to forget after finishing their school days. Very few men are able to dictate a letter satisfactorily, and it is believed that by reviews and writings of this kind, that important branch of business will be strengthened.

THE PRINCIPLES OF SCIENTIFIC MANAGEMENT, by Frederick Winslow Taylor. Published by Harper & Bros., New York and London. It contains 144 pages octavo cloth; price \$1.50 net. The search for better and more competent men, from the presidents of our great companies down to household servants, was never more vigorous than it is now, and more than ever before is the demand for competent men in excess of the supply. What we are looking for, however, is the ready-made competent man, the man whom some one else has trained. "It is only when we fully realize that our duty as well as our opportunity lies in systematically cooperating to train and make this kind of man instead of hunting for a man whom some one else has trained, that we shall be on the road to

national efficiency." In the past the man has been first, in the future the system must be first. This in no sense, however, implies that great men are not needed. On the contrary, the first object of any good system must be that of developing first-class men, and under systematic management the best man rises to the top more certainly and more rapidly than ever before.

Mr. Taylor has written his book, first, to point out through a series of simple illustrations the great loss which the whole country is suffering through inefficiency in almost all of our daily acts. Second, to try to convince the reader that the remedy for this inefficiency lies in systematic management rather than in searching for some unusual or extraordinary man. Third, to prove that the best management is a true science, resting upon clearly defined laws, rules, and principles as a foundation.

The book is divided into two chapters, the first one being Fundamentals of Scientific Management, and the second one being on the Principles of Scientific Management. The whole book is of interest and appeals to employers.

BUREAU OF MINES, Washington, D. C., Bulletin No. 7, Essential Factors in the Formation of Producer Gas, by J. K. Clement, L. H. Adams, and C. N. Haskins. On page 19 of this bulletin is a discussion of Physical-Chemical Principles, on Application of the Laws of Chemical Equilibrium and Reaction Kinetics. Prof. C. N. Haskins, one of the authors, evidently imagines that a bulletin of the Bureau of Mines is primarily intended for the exhibition of his knowledge of higher mathematics. After wading through several pages of matter that to the average mining man looks as intelligible as a series of Chinese laundry tickets, we find in the summary the following useful information: To obtain a higher percentage of CO, the producer fuel bed should have a temperature of 1,300° C. or over; and that increasing the depth of the hot portion of the bed will increase the percentage of CO generated and consequently the capacity of the producer, at first rapidly and then more and more slowly. Also, to minimize the production of CO in the boiler furnace the fuel bed should be thin. Increasing the velocity of the gas will tend to decrease rather than increase the percentage of CO formed; both of which conclusions are evident to most men without the use of Calculus.

BOOKS RECEIVED

UNITED STATES GEOLOGICAL SURVEY PUBLICATIONS, Washington, D. C. Bulletin No. 438, Geology and Mineral Resources of the St. Louis Quadrangle, Missouri-Illinois, by N. M. Fennerman; Bulletin No. 453, Results of Spirit Leveling in Minnesota, 1897 to 1910, Inclusive, by R. B. Marshall, Chief Geographer; Bulletin No. 460, Results of Spirit Leveling in Iowa, 1896 to 1909, Inclusive, by R. B. Marshall; Bulletin No. 461, Results of Spirit Leveling in Michigan and Wisconsin, 1897 to 1909, Inclusive, by R. B. Marshall; Bulletin 470-E, Advance Chapter From Contributions to Economic Geology, 1910, Rare Metals, by F. L. Hess; Bulletin No. 470-I, Advance Chapter From Contributions to Economic Geology for 1910, Mineral Paints, by B. L. Miller; Bulletin No. 470-J, Advance Chapter From Contributions to Economic Geology for 1910, Sulphur and Pyrite, by R. W. Richards and J. H. Bridges; Bulletin No. 470-K, Advance Chapter From Contributions to Economic Geology, for 1910, Miscellaneous Non-metallic Products, by J. S. Diller, Charles Butts, A. N. Winchell, N. H. Darton, and E. F. Burchard; The Production of Fuller's Earth in 1910, by Jefferson Middleton; The Production of Quartz and Feldspar in 1910, by Edson S. Bastin; Gold, Silver, Copper, Lead, and Zinc in the Western States and Territories in 1909, by A. H. Brooks, C. N. Gerry, V. C. Heikes, C. W. Henderson, H. D. McCaskey, Chester Naramore, and C. G. Yale; Summary of the Mineral Production of the United States in 1909, by W. T. Thom; Statistics of the Clay-Working Industries in the United States in 1909, by Jefferson Middleton; The Stone Industry and the

Manufacture of Lime in 1909, by Ernest L. Burchard; The Production of Abrasive Materials in 1909, by W. C. Phalen.

FORTY-FIRST ANNUAL REPORT OF THE BOARD OF DIRECTORS OF CITY TRUSTS OF THE CITY OF PHILADELPHIA FOR THE YEAR 1910. Frank M. Highley, Secretary, Stephen Girard Building, 21 S. 12th Street, Philadelphia, Pa. This has to deal with the management of the Girard estate and some invested capital derived from that estate. In the year 1910 the cash receipts from the estate amounted to \$1,940,815.11 gross, and \$1,342,920.75 net.

NOTICIA DOS ESTUDOS E OBRAS CONTRA OS EFEITOS DA SECCA, by Antonio Olyntho dos Santos Pires, Rio de Janeiro, Brazil. This book is a government publication relative to water supply in various states of Brazil. It is handsomely illustrated.

ANNALES DES MINES DE BELGIQUE for the year 1911, Volume 14. Published by the Bureau of Mines, Brussels, Belgium. The leading article is by Joseph Libert, Inspector General of Mines in the Province of Liege, on the Hygiene of Mines. It also contains a very interesting document giving the list of explosives permitted by the chief engineer and submitted to the Minister of Industrial Affairs, Arn. Hubert. This report gives the materials making up explosives.

INFLAMMATION OF GAS THROUGH THE FILAMENTS OF ELECTRIC LAMPS, by Emanuel Lemaire. Extracted from the Annales des Mines of Belgium, Volume 16. Published by L. Narcisse, Brussels, Belgium.

QUELQUES MOTS SUR LE DEVELOPPEMENT RECENT DU PROCEDE DE CREUSEMENT DES PUIITS PAR CONGELATION ET SUR LA SECURITE DANS LE FONCAGE DES PUIITS, by Ad. Breyre. Published by L. Narcisse, Brussels, Belgium.

BUREAU OF SCIENCE, Manila, P. I. The Philippine Journal of Science, Physical and Chemical Properties of Portland Cement, Volume 5, No. 6; Eighth Annual Report of the Bureau of Science, by Richard P. Strong; Ninth Annual Report of the Director of the Bureau of Science, by Paul C. Freer.

MINING LAWS OF THE STATE OF ALABAMA, Secretary of State, Montgomery, Ala.

BIENNIAL REPORT OF THE INSPECTOR OF COAL MINES OF THE STATE OF MONTANA, for the years 1909-10, Joseph B. McDermott, Inspector, Helena, Mont.

TENNESSEE STATE GEOLOGICAL SURVEY, George H. Ashley, State Geologist, Nashville, Tenn., Bulletin No. 13, A Brief Summary of the Resources of Tennessee for the homeseeker, investor, business man, farmer, and others. This bulletin shows Tennessee resources by means of pictures and short articles.

REPORT OF THE MINE INSPECTOR FOR THE TERRITORY OF NEW MEXICO TO THE SECRETARY OF THE INTERIOR, for the fiscal year ended June 30, 1910. This may be had by application to the Secretary of the Interior, Washington, D. C.

THE RELATION BETWEEN THE TENSILE STRENGTH AND TRANSVERSE STRENGTH OF RAW CLAYS, by H. Ries and S. W. Allen, Ithaca, N. Y. This is a reprint from the Transactions of the American Ceramic Society.

BULLETIN No. 1, Mineral Resources of Wyoming, Mining Laws of the State and of the United States, by C. E. Jamison, State Geologist, Cheyenne, Wyo.

VOLUME I, PORCUPINE SERIES. The publishers of the *Canadian Mining Journal*, Toronto, Ontario, in view of the fact that the demand for back numbers containing articles on Porcupine cannot be met, are bringing out a book embodying descriptive, geological, and general data relating to Porcupine. This book will also include 13 township maps with all claims recorded up to April 11 and the latest Departmental geological map. The contents are: Introduction; Discovery of Porcupine; five illustrated articles on the district; claim maps of Godfrey, Mount Joy, Tisdale, Whitney, Cody, Ogden, Deloro, Shaw, Carman, Price, Adams, Eldorado, and Langmuir; latest departmental geological map; directory of companies; map of Keekeek District, with article. The price is \$2 per volume.

Personals

G. T. Hansen, who has been connected with the Allis-Chalmers Co. for several years in the capacity of metallurgical engineer and has had a varied experience in the mining fields of this country and in Mexico, has been appointed manager of the Salt Lake City office of the Allis-Chalmers Co.

Walter H. Finley, who for the past five years has been in charge of the active management of the Sterling Coal and Coke Co., of Middlesborough, Ky., has accepted the position of general manager of the Campbell Coal Mining Co., operating mines at Westbourne, Jackson, and Eagan, Tenn., and Coalmont, Ky. He will have his headquarters at Westbourne, Tenn.

W. H. Grady has resigned the position of superintendent of the Seaboard Coal and Coke Co., of Coal City, Ala., to become chief engineer of coal mines of the Tennessee Coal, Iron, and Railroad Co., Birmingham, Ala. His office will be at Rooms 1348-9, Brown-Marx Building, Birmingham, Ala.

Joseph B. Noros, formerly with the Scranton Electric Construction Co., has opened a branch office for the business of the Jeffrey Mfg. Co. at 225-226 Miller Building, 420 Spruce Street, Scranton, Pa.

W. R. Bauder, of Negaunee, Mich., has been appointed general superintendent of the Exploration Syndicate of Ontario, Ltd., Wilbur, Ont.

Baird Halberstadt, F. G. S., of Pottsville, Pa., was the geological expert who established the identity of the B bed of the Lower Productive Coal Measures in the three suits instituted by farmers against Berwind-White Coal Co.

R. G. Mackie, resident engineer of the Geldenhuis Deep, Ltd., Transvaal, S. A., furnishes an interesting account of a new tube mill intended to replace the stamp mill.

John A. Finch, of Spokane, Wash., has been inspecting the zinc-lead properties of his firm at Silverton, B. C.

A. Klockman, President of the Idaho-Continental Mining Co., has returned to Spokane, Wash., after inspecting the company's property in the Kootenai district.

H. W. Woodward, of Lynn, Mass., has secured a 10-year lease on the upper tunnel of the Moonlight property in the Cœur d'Alenes.

Dr. T. X. Schaeffer, Professor of Geology at the University of Vienna, who was invited by the Carnegie Institute to witness the unearthing of the antediluvian monsters in Utah, announces that he will return early in August to make a careful study of the Cœur d'Alene district, also visiting other camps in the inland empire.

W. R. Ingalls, J. Parke Channing, Doctor James Douglas, J. R. Finlay, and John Hays Hammond, have been appointed consulting engineers for the United States Bureau of Mines.

Edward M. Rabb, Jr. has returned to Denver after a six weeks sojourn in the Southwest.

Rescue car No. 5 of the United States Bureau of Mines is in charge of Sumner S. Smith, mining engineer, with headquarters at Rock Springs, Wyoming.

Charles W. Newton, Superintendent of Butte Ballaklava Copper Co., Butte, Mont., has been visiting Detroit and Duluth on business.

W. H. Kemp, who has been in charge of the advertising of The Goulds Mfg. Co. for the past five years, has tendered his resignation. He will be succeeded by C. H. Clark, who will be in charge and give his attention to all matters relating to the advertising of the company.

W. P. Jennings, of Pittston, former district superintendent of the Pennsylvania Coal Co., has been appointed mine inspector for the 8th Anthracite district to succeed P. M. Boyle, recently deceased.

S. J. Phillips has been appointed acting inspector of the 4th Anthracite district to take the place of H. O. Prytherch during the latter's absence.

COAL MINING AND PREPARATION

"Safety the First Consideration"

Methods Employed by the H. C. Frick Coke Co. for the Prevention of Accidents to Employees

By Stephen L. Goodale*

Since about the 1st of January this legend has appeared on all letterheads, circulars of instruction to officers at the mines, blank forms to be filled out at the mines, and generally on all stationery of the H. C. Frick Coke Co. Up to the present time it has been mostly added in red ink with a rubber stamp, but whenever a new supply of stationery is needed the words are printed in red conspicuously as a part of the form.

For some years this company has conducted, under the able leadership and constant insistence of Mr. Thomas Lynch, president of the company, a strenuous campaign to make the mining of coal and other work about their properties as safe as possible. Four men were sent abroad to study what had been done in Europe and to get all assistance possible from countries which had been reported to have small numbers of accidents. This campaign is still in the course of development, but a very great deal has been already accomplished, and many improvements of the most vital importance have already been made. We can, therefore, describe now only the present state of development of a department that is showing the rapid growth of a healthy infant; but there is now so much to write about, and the subject of safety in the mine is of such great importance, that it cannot receive too much attention from mining men and others who can assist.

The keynote of all this work is *prevention* of accidents. The means employed are firstly educational, and secondly a number of actual safety appliances and methods of work.

"Safety First" demanded above all a campaign of mutual education. "First we had to educate the steel corporation to the necessity of such work, then they had to educate us how to carry on the work, and now we have to educate our foremen and bosses and miners to carry out the regulations made and how to use the safety appliances provided," as one superintendent put the case—mutual education—a cooperative system among the leaders. That the company has been thor-

oughly convinced of the great need is proven by the money it has spent and is spending to make its mines and mining and surface works safe places to labor. A live interest and even keen rivalry exists among the superintendents and others at the different mines in furthering the movement for safety first. It took a good while to convince these men that the company was really in earnest, and that the movement was something more than a spasmodic interest, or a temporary spurt for appearances only; but, as one device after another was introduced for safety, and appropriations were made again and again for this purpose, the foremen and superintendents have not only

been convinced of the good intentions of the management but have become very zealous assistants in the same cause themselves. These men are studying the problem of safety, both in their everyday work from the practical side and also to make it more effective from the theoretical side as well. Evening meetings and periodical conferences for study and discussion of mine and safety problems are so numerous for many of them that one is reminded of the engineer who said that to keep up with the procession in electrical engineering he had to work all day and study all night.

Of great value in this educational scheme are the signs which are posted everywhere about the properties. The miner who is seeking employment, or as they express it, "trying to catchee a job," is first confronted with the sign in big letters:

"To men seeking employment: Unless you are willing to be careful to avoid injury to yourself and fellow workmen do not ask for employment. We do not want careless men in our employ."

The sign, "Safety First," printed in five languages, is hung or to be hung in the

superintendent's office, shop, boiler room, inside and outside engine room, power buildings, mine pump rooms, and all other machinery rooms, at the mine entrance—whether slope or shaft—at the shaft bottom, and everywhere around the plant where they will intrude themselves on the attention of the employees and the public. In addition, a "Safety First" illuminated sign is to be hung at each mine at a point where it will prove most conspicuous to men entering or leaving the mine, probably in the manway. "The sign will be double glass, showing the legend in two directions; it will be illuminated by electric lamps. It is also desired to place an additional illuminated sign on the surface near the entrance to the mine."

WARNING!

EMPLOYEES WORKING AROUND
ENGINES, MOVING OR REVOLVING
MACHINERY, SHAFTING, ETC.,
ARE WARNED OF THE

DANGER

AND ARE PROHIBITED FROM
WEARING TORN CLOTHING,
LOOSE OR UNBUTTONED JACKETS,
BLOUSES, SHIRTS, LONG NECKTIES
AND LOOSE SLEEVES. ALWAYS
WEAR THE OVER-ALL JACKETS
TUCKED IN THE TROUSERS
OR UNDER THE OVER-ALL BIB.
NEVER FORGET TO EXAMINE
YOUR CLOTHING BEFORE
COMMENCING WORK.

H. C. F. C. Co.

Fig. 1

*Professor of Mining University of Pittsburg.

The rules and regulations of the company, printed in five to seven different languages and comprising 28 articles, are conspicuously posted at all the mines in several places, and no one can be ignorant thereof who is employed at these mines. They are posted at such places as the lamp house, and the waiting rooms, at top and bottom of the shafts, etc., where they are not only conspicuous, but the men also have the best opportunity in the ordinary course of events to peruse them. These are given herewith in full:

RULES AND REGULATIONS OF THE H. C. FRICK COKE CO.

1. Strict compliance with the Mining Laws of the State of Pennsylvania shall be the first duty of each and every employe, at all times and under all circumstances; and SAFETY must be the first consideration of superintendents, mine foremen, and all others exercising authority or charged with the direction of operations in every department; quality of product second; and, cost of production third.

2. Mines generating explosive gas must have, at the intake, not less than 500 cubic feet of air per minute per person employed in the mine, and so distributed that there will be sufficient volume in circulation in and around working places to give not less than 300 cubic feet per minute, per person employed in each "split." No mine shall have less than 300 cubic feet of air per minute, per person employed, at the intake, with sufficient volume in and around working places to give, at least, 150 cubic feet per minute, per person employed in each "split."

3. Dangerous accumulations of explosive gas must not be permitted in "gobs" or other parts of the mines; if the same cannot be removed with the air-current, release it by means of bore holes from the surface.

4. In all mines where blasting of coal is permitted, all shot firing must be done with the consent, in the presence and under the supervision of the mine foreman, fire boss, or other competent person designated by the mine foreman; and the person designated by the mine foreman to supervise the blasting, or some other person designated by the mine foreman, must visit all the places where shots have been fired as soon as practicable after shots have been fired, to see that the roof is safe and that there is no fire or other danger.

5. Provide and maintain a system of pipes, and a supply of water with sufficient head, and all other necessary appliances, to thoroughly dampen the floor, sides, and roof of all places, in dry mines, where dust is a menace to safety; have the water head sufficiently strong to wash the dust from the roof and sides of these places, if need be, to make them safe, and have regular stated intervals for such watering or washing.

6. Employ steady, reliable, sober men only, in the capacity of mine foreman, fire boss, master mechanic, hoisting engineer, boiler and fan tenders, and stable boss; and the use of intoxicating liquors by any employe while on duty is absolutely forbidden.

7. Air-shafts must be kept open and free, at all times, from ice or other obstructions, and superintendents shall personally examine the air-shafts and stairways therein, and travel

either up or down same at least once in each 2 weeks; he shall also see that the cages and safety catches are tested at least once in each 2 weeks, and that the hoisting ropes on cages used for lowering and hoisting men in and out of the mines are taken off as soon as they show any defect or weakness, from wear or other cause, but in no case shall ropes on such cages be kept in service longer than 2 years, even though apparently safe and in good condition.

8. Oils or explosives must not be stored in the mine, and no person shall be allowed to take more than 1 day's supply of oil or explosives into the mine at one time.

9. The best and safest oils that can be procured must be used for illuminating purposes in the mines and mine buildings above ground; and the best and safest explosives that can be procured must be used for blasting in the mines.

10. Engine rooms, pump rooms, power houses, boiler houses, and stables, both in the mine and above ground, must be well ventilated and kept neat and clean at all times. Provide cans in all these buildings for storing oils, oily waste, grease, etc. The use of open lights in any of these buildings,

either under or above ground, is strictly prohibited. Hay and straw must be taken into the mines in bales—not loose.

11. All electric wiring, whether used for lighting or power, must be carefully installed in the most approved manner, and thoroughly examined by some competent person at least twice a year.

12. A system for checking men in and out must be maintained at all mines, which will show how many men, and who are in the mines at all times.

13. Fire hose of ample size and length must be maintained near the mine buildings, or some other convenient place at each plant; a sufficient number of ladders of proper length must be kept on the dwelling houses and mine buildings; barrels filled with water and salt, and fire buckets must be maintained on trestles, in tipples, engine and boiler houses,

and other buildings where fire is likely to occur—all for use in case of fire only.

14. The use of safety lamps and open lights must not be permitted in the same mine, except only upon the joint recommendation, in writing, of the mine foreman and the company's mine inspectors. Lights must be carried on the front and rear of all trains of cars "or trips" (including trips on slopes) controlled by motors, steam engines, or other mechanical means.

15. Finger boards must be maintained in all mines, which will plainly indicate to persons employed therein, the way out of the mine.

16. Each and every mine must be visited and thoroughly inspected by the company's mine inspector at least once in every sixty (60) days, who shall report condition of same, in writing, to the general superintendent.

17. The superintendent, mine foreman, fire boss, yard boss, master mechanic, hoisting engineer, stable boss, boss driver, boss roadman, and such other employes at each plant as the superintendent or mine foreman may designate, shall meet at least once every week, at the time and place designated by the superintendent, to exchange views, discuss the mine conditions

**PLACE NO MORE LOAD THAN
9,000 LBS.
ON THIS CAGE.**

**HANG NO MORE LOAD THAN
15,000 LBS.
ON THE FREE ROPE.**

**IN EACH CASE, HOIST SLOWLY
AND WITHOUT JERK.**

$\frac{13}{8}$ ROPE

FIG. 2

and operations generally, and especially matters pertaining to the protection of the lives and health of the employes, and the care and safety of the property.

18. Mines in which safety lamps are used must be thoroughly examined by fire boss, or other competent person, on Sundays, holidays, and lay-off days, and all mines which have been idle for two or more consecutive days must be thoroughly examined by some competent person the day before operations are resumed.

19. No one will be permitted to interfere with the religious or political opinions of the workmen, and no superintendent, foreman, boss, or clerk will be allowed to solicit money or make collections from the workmen for any church, society, or association.

20. Any employe wishing to be absent from duty must, before going, apply to and receive permission from his immediate superior.

21. Superintendents and foremen shall see that the "turns" are fairly distributed among the workmen on contract or piece work, and that no more men are employed than are absolutely necessary to perform the required amount of work well and at the proper time.

22. All employes are requested to exercise care and economy in the use of materials and supplies, and any employe who through carelessness or malice wastes materials or destroys the property of this company, or is found stealing or carrying away the property of this company, will be discharged.

23. Any workman offering money, liquor, or valuables of any kind to a foreman, boss, or clerk will be subject to discharge, and any foreman, boss, or clerk accepting money, liquor or valuables of any kind from workmen will be summarily dismissed.

24. Superintendents must pay strict attention to the rights and privileges of all employes; hear and give prompt attention to any reasonable complaint or claim for redress made by any employe, and not allow any discrimination on account of nationality or creed.

25. Every salaried employe of this company is expected to devote his entire service to the work and interests of his employer, and while no restriction is sought to be placed upon employes in the matter of making investments, no salaried employe shall take active part in conducting the business in which an investment is made; nor will such employe be permitted to influence any other employe of this company to buy or in any way assist in the sale of the products of said business.

26. It shall be the duty of superintendents, foremen, bosses, and clerks to strictly comply with and rigidly enforce the above rules.

27. These rules are intended to supplement, not to supplant in any manner or form, any of the requirements or provisions of the mining laws of the state of Pennsylvania, and printed copies of same in the English language, and other languages used by the workmen, must be kept posted in conspicuous places, at all mines, and the attention of all persons must be called to same, when hired, as well as to the printed special and general rules furnished by the State Mine Inspectors.

28. It shall be the duty of all employes to report any violation of the mining laws, or of these rules, to the superintendent of the plant where the offense is committed, and it shall be the duty of the superintendent to immediately report any violation of the mining laws, which may come to his notice, to the State Mine Inspector of the district and to the general superintendent; also, to report any violation of these rules to the general superintendent.

W. H. CLINGERMAN,
General Superintendent

Approved: THOS. LYNCH,
President

The sign, Fig. 1, here reproduced in miniature, warning employes of the danger of torn clothing, is one which might well be posted in all machine shops and places where rapidly moving machinery is in use.

In addition, a small sign is used, directing that all machines considered dangerous to oil or wipe while running should be stopped to oil, wipe, or repair. The former sign is to be posted "in all power buildings, such as compressor, or electric stations, not less than two signs, one at each end of the room; in all shop buildings, at least two signs, one at each end of the room." The signs are to be placed also in any additional places which seem to require them. The latter sign is to be applied most conspicuously to all machinery such as "hoisting engines and haulage engines (each side), to electric generators, to high-speed steam engines, to electric motors, to electric pumps, etc. It is not considered necessary to apply them to such slow-moving machinery as direct-acting steam or air-driven pumps." These two signs are made of sheet metal with white letters on a background of blue enamel.

The sign shown in Fig. 2 is placed as a framed placard under glass on the head frame at the ground landing, as instruction to the operatives for any weights that may have to be handled. This would apply to machinery parts, pumps, compressors, etc., or other unusual loads which are handled into the mine. There are many places where this idea might well be copied, such, for instance, as the cranes in industrial works.

A number of other signs will be mentioned in connection with appliances to which they especially refer. It may be well

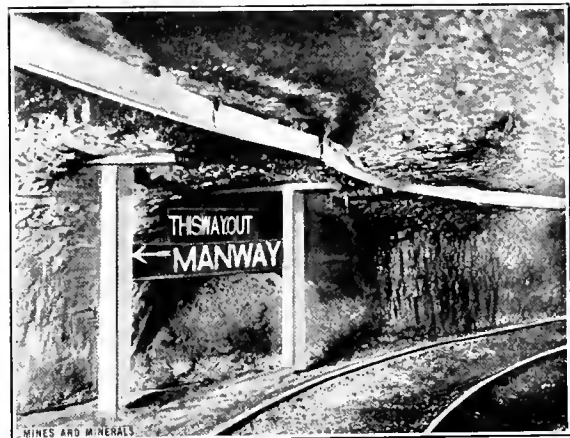

FIG. 3

to add here perhaps a mention of the guide or directional signs such as illustrated in Fig. 3.

These guide signs are placed at a sufficient number of points underground so that even a stranger in the mines could probably find his way out with no great difficulty. Besides this particular sign, dangerous workings are so marked to avoid men going into such dangerous places unnecessarily. The danger signs are white letters on a red background; the directional signs white letters on a black background.

But signs don't do much good unless they are read, understood, heeded, and obeyed. To make them read, they are put up in many prominent places; for understanding, they are translated into from four to six European languages, according to the nationality of the workers, who do not "versthey too much" English. As for attending to these instructions, and obedience on the part of the men, that is where the difficulty comes in. Many a man will take chances of danger to save himself a little inconvenience if he thinks the danger small, or he may even take Hamlet's view "There's such divinity doth hedge a king." You can post a large sign on the main haulage way that no one is allowed to walk there, and in spite of the notice men—and especially those who ought to know better—will often walk that way if they can thereby save a longer walk. If such a man is killed in that kind of place, whom can you punish? He had a right to go by the manway,

and was on the haulageway against strict orders. Every breach of discipline must be punished by appropriate means if this kind of thing is to be ended. The man who will not obey the regulations of the coal mines is just as much a menace to the lives of those in the mines as would be the railroad locomotive engineer who disobeyed his orders.

It is not ordinarily the ignorant immigrant fresh from steerage who takes these risks—he is warned by the signs in his native language, and by his older compatriots, and he obeys—he is too much afraid not to obey. Mr. Lynch states that in his own experience he has not known of any casualties to such men who have been less than 2 years in the mines. It is men who know of the dangers, but think—and have not made sure—they have provided for them, and who often go into places to which their duties do not call them; 66 per cent. of all the fatalities last year were to intelligent men who had had long experience in mining.

Perhaps the most important item in securing obedience to the rules and regulations is having the superintendents and foremen personally and vitally interested. And in this safety work Mr. Lynch, the moving spirit for safety, has certainly enlisted the active cooperation of his employes from superintendent down to the actual diggers of coal, the "mule-skinners," or even, we may also say, the unemployed miner who is trying to get employment. The willingness, interest, obedience, and cooperation of the employes, which is very marked at all the mines, is, therefore, even a more important factor than the numerous signs and notices of rules and regulations required to make "safety the first consideration."

The end sought in all this work is prevention of accidents. The oxygen helmets, the hospitals, the first-aid training, and all such, are at best but a makeshift. They are like locking the door of the stable after the horse is stolen; but it is rather the constructive making the mines safe, making accidents impossible, toward which Mr. Lynch's efforts are directed. The company has, indeed, three rescue training stations, and has spent much money in training men. It has also hospitals at the various mines, but these are all thought of as of very secondary importance as compared to the prevention of accidents.

柔 柔

Internal-Combustion Engines in Mines

In the Consular and Trade Report of June 28, 1911, is found the following on internal combustion engines in Europe.

The chief inspector of mines of the British home office in an interview stated it to be his belief that there were no gasoline motors used in coal mines in England, though there might be some few exceptions of which he did not know. An Austrian engineering company, which has a branch in England, manufactures a gasoline motor locomotive for special use in mines. While it has succeeded in placing its engine in mines on the Continent, the London manager advises that he has not yet so succeeded in England. The danger from the use of such engines in mines is deemed to be so great that they have not yet found a foothold in England.

Gasoline, benzine, and benzole locomotives are used in the mines of Germany. The motors are usually low speed and are operated principally as locomotives for the transportation of freight and passengers. Stationary motors, however, are sometimes used for driving compressors, blowers, ventilators, etc.

The exact number of explosion motors which are used in the German mines is not known, but one of the largest motor-manufacturing companies of Germany estimates that about 1,000 are being operated at the present time. From information obtained from reliable sources, the use of liquid-fuel motors in the mines of Germany has not increased during the past 2 years, except in Lower Silesia.

Gasoline motors are widely used in Austria for stationary and mine engines. There is one maker of mine locomotives.

Coal-mining companies in Austria very generally use explosion motor locomotives. The use thereof in mines is under rigorous inspection and control. The explosion locomotives used in mines are, as a rule, supplied by German manufacturers, though they are beginning to be built in Austria.

As a general rule the extensive subdivision of mining properties and the irregularity of the Belgian coal measures render Belgian coal mines ill adapted for the installation of locomotive transport for subterranean work.

During the last 2 years, however, 12 colliery companies have obtained permission to introduce benzine locomotives into their mines as an experiment. The introduction of these engines is too recent to admit of a definite decision being given as to their use. It is sufficient to mention that many companies, after having introduced these experimental locomotives in one of their mines, have later sought permission to introduce them into other mines. The use of these locomotives is never authorized in mines of the third class, where firedamp is liable to escape suddenly; many, however, are working in mines of the first and second class, where firedamp is present, but they are used exclusively in the principal air galleries. These locomotives have never yet caused any explosion or other accident. The conditions under which permission is accorded for their use are very stringent. It is also to be noted that these permits are only granted temporarily, and on condition that they may be revoked at any time if the inspector of mines considers the use of locomotives undesirable.

Motor locomotives were used for the first time in the Netherlands coal mines in the year 1907, benzine being the only fuel. Since then the number of motor locomotives in use has increased considerably, but the type of benzine locomotives has been adhered to. At present, out of the six mines working, transport in the main galleries in four of them is almost exclusively carried on by means of benzine locomotives. At present in the four Netherlands mines in question there are the following engines: one of 16 horsepower, seven of 12 horsepower, five of 10 horsepower, three of 8 horsepower. The managers of the mines are entirely satisfied with the results of the use of benzine locomotives for transport, and are of the opinion that a considerable saving has been effected thereby. The number of locomotives is therefore shortly to be increased. The number of mining cars containing 500 kilos (1,102 pounds) that these locomotives can draw depends upon the gradients existing in the main galleries; but it amounts in the case of locomotives of 12 horsepower, in a mine where the gradient is small, to 66 cars.

From the point of view of safety of transport with benzine locomotives it must be stated that the section of the galleries in which such traffic takes place should allow sufficient free space. It has sometimes occurred, owing to a car becoming derailed and thus knocking over a wooden prop, that considerable falls, and consequently serious accidents have happened. In cases where it is difficult to increase the section of the galleries, this danger has been successfully avoided by placing iron plates on the wooden props, so that the wagons when derailed glide off them but do not knock them over. Finally, it is important that in the places where benzine locomotives are used, there should be sufficient ventilation, as otherwise combustion products which are dangerous to health may accumulate.

柔 柔

Anthracite Record Broken

The first six months of 1911 exceeds in point of production all previous outputs of coal in the anthracite region. The total number of tons was 35,309,583. The highest previous tonnage was for the six months ending June, 1907, and was 32,884,595 tons. The Lehigh Valley produced 19.55 per cent.; the Reading, 18.27 per cent.; the Lackawanna, 14.59 per cent.; New Jersey Central, 14.10 per cent.; Delaware and Hudson, 9.72 per cent.; the Erie, 12.60 per cent. of the total in 1911. The apparent consumption of anthracite for the first six months is 35,289,000 tons.

Coal Mining in Arkansas

Method Used in Stripping Shallow Seams and in Mining Thin Seams With Partings

By A. A. Steel, B. S.*

In Arkansas, if the parting of a coal seam is hard and over 16 inches thick, and also if the top or bottom bench of coal is thin or impure, only the thicker or better part of the seam is mined, and one or more of the benches is left. It will be nearly impossible to mine this coal after the mines have fallen in, and it may be considered as permanently lost.

As yet, it is unprofitable to extensively mine both benches of a seam containing a parting unless there are 3.5 feet of bituminous coal or 2.5 feet of semianthracite coal. In this case, the parting must generally be not more than 2 or 3 inches thick. At Russellville, however, one seam is mined that aggregates only 24 to 30 inches of coal and is divided by 16 inches of waste; but this coal is very valuable, the parting is soft, and most of the other conditions favorable.

Clean beds of coal are mined rather extensively even where only 20 to 24 inches thick, provided other conditions are favorable; but usually the minimum thickness for profitable mining is from 28 to 32 inches. As yet no coal has been mined at a depth of more than 480 feet below the surface. The roof is usually good with the exception of a few inches of "draw slate" or a few inches of soft earthy material called "black jack" or "rashing." The floor is generally good. The combined thickness of the coal, its partings and the draw slate over it, determine the height of the place in which most of the miners have to work. Where only one bench of coal is worked, or the seam is clean, this height ranges from 2 feet 10 inches to 4 feet 6 inches, except in rather extreme cases. The least height in the double-bench seams is about 3 feet in some of the semianthracite mines near Clarksville, where the parting is 3 inches thick. The height of the working places is seldom over 8 feet, which is common in the soft-coal districts, where the parting may be as much as 12 or 14 inches thick. In a few places where the partings are soft and easily handled and near the middle of the seam, three benches of a coal seam are worked together. Such seams have from 4 to 6 feet of coal and 12 to 14 inches of waste. In some places where the coal outcrops and the coal bed is fairly flat so that the cover does not soon get too thick, open-cut mining is practiced as in Fig. 1.

The cover is loosened with plows and removed with scrapers, and as the coal goes deeper under cover and becomes covered with shale, it is first shaken up by blasting before it is plowed. Churn drills having 2-inch bits are used to make a row of holes about 6 feet deep, 12 feet apart, and about 8 feet back from the face. In order to chamber the holes for a large charge of black powder (25 pounds) each hole is sprung by discharging a single stick of dynamite in the bottom of it. This pulverizes the shale near the bottom and throws the dust out through the top of the hole. After the powder is poured into the chamber

thus formed, and the fuse inserted, the hole is tamped with earth. Under ordinary conditions, it pays to strip the coal until the shale cover becomes four times as thick as the coal, that is, 1 foot of coal will stand the removal of 4 feet of shale.

If the seam is inclined and the railroad tracks can be conveniently brought to the outcrop, a slope excavation from 8 to 14 feet wide is driven on the dip of the seam from the surface. If the coal bed is thin, some of the slate roof is shot down or "brushed" to make headroom, but even then the height is seldom more than 5 feet, and the miners must generally stoop while walking in the slope. Fig. 2 shows the brushing in an entry. At intervals of about 300 feet "entries" or passageways are driven right and left from the slope in such a direction they are nearly level. If the coal is low, the roof is taken down or "brushed" until there is a height of 4 feet 6 inches above the rails laid in them, so that a mule 14 hands, or 4 feet 8 inches high, can walk between the ties and not strike the roof.* After the entries have gone a short distance from the slope, rooms are turned every 36 feet along the upper side of the entry. The "room necks" or beginning of the rooms are 8 feet wide for a distance of 12 feet and they are then widened to 24 or 30 feet, or whatever has been decided shall be the width of the room. This leaves a pillar of coal from 6 to 12 feet between the rooms as a support for the roof. The rooms are seldom

more than 250 feet from the entry to the extreme end or face. There is a switch in the entry track at the neck of each room, as shown in Fig. 3, in order that the mine cars may be pushed to the face of the room where the miner can load one at a time. The miner lays the track in his room as it needs extending, using wooden or light iron rails for the purpose.

In the entries the cars from the rooms are made into trips, generally of three large cars or five small ones. A single mule hauls these trips down the



FIG. 1. STRIP PIT NEAR HUNTINGTON, ARK.

gentle grade to the beginning of the entry where there is a wide place with a short length of double track. This is called the parting. Here the driver leaves the loaded cars on the main track and takes the same number of empty cars from the side track and goes back through the entry to the rooms. If the coal is high enough, he takes the cars one at a time to the face of the rooms with the mule. If the coal is low the miner helps the driver to push the empty car up the room while the mule waits, as the roadway in the room is seldom brushed to a height sufficient to admit a mule. At the entry partings the loaded cars are coupled into rope trips by the drivers. When there are enough cars for the trip the driver waves his light to the rope rider who rides up and down the slope with a train of cars. He lets a train of empty cars down into the parting, fastens the rope to the loaded trip, and signals by electric bell to the hoisting engineer, who winds up the rope and so pulls the loaded cars out into the entry and up the slope.

To get rid of the little gas that is always present and to furnish pure air for the men and mules, a strong current of air must be passed through the mine. For this purpose slope air-courses are driven usually on both sides of the main slope. They are just like the main slope except that they are sometimes wider and are rarely brushed. At the mouth of these

* This is not high enough or the mule is too high; besides, there should not be holes between the ties.

* Fayetteville, Ark.

air-courses is placed a large steam-driven fan. The fan draws a strong current of fresh air down the slope which circulates through the mine and passes up the air-courses. The current from the air-course opposite the fan is carried over the slope in a passage blasted out of the rock above and separated by a tight wooden tunnel through which the cars pass. This is called an overcast.

From the face of each entry the gases and impure air are drawn out to the slope air-courses by another passage just like the entry except that it is seldom brushed. This is along the lower side of the entry opposite the rooms, and a chain pillar usually 12 feet wide is left between them. In Arkansas this passage is generally called the "back entry" and sometimes the "smoke room" or simply "air-course." As the entries are driven forward they are connected at intervals of 30 or 40 feet by cross-cuts or breakthroughs. All but the last of these are carefully closed, generally by tight board stoppings. As soon as a room is widened out it is connected to the adjoining room by a cross-cut through the pillar and the air-current is made to

Fig. 4 shows such a door. The white patches on it are due to a fungus which rapidly destroys mine timbers. After the first room is holed through, the door is usually placed at the inner end of the parting; and to save delay in hauling, a boy is hired to open and close it for the driver. Fortunately, the law requires that these trappers be over 14 years old, and, of course, the work is very light. The trappers all want to be drivers when they are 16, so they often help the driver.

As soon as the first room beyond the parting is holed through, the slope air-course is no longer needed for coursing ventilation, and the stoppings at the entry chain pillars can be removed to give an unobstructed passage up to the first entry. It is therefore used as a traveling way, or manway, by the miners, who thus avoid injury from the rapidly moving trips of cars in the slope. It can also be used as an exit when the main slope is blocked, provided the stoppings at the first entry and the fan house are fitted with small doors.

Whenever the face of a room or entry cuts so far beyond the last cross-cut that a pocket of gas collects in it, the air-current



FIG. 2 BEGINNING AN ENTRY IN LOW COAL (By courtesy *The American Lumberman*)

pass through this breakthrough by hanging a curtain of two overlapping strips of canvas across the entry. A mule can pull the cars through this without delay, and even though a little air may blow through it, enough will go to the room face to keep the gas from collecting there. While the slope air-course is being extended, the air current passes down the main slope to the last cross-cut, and through this to the slope air-course and up to the course of the lowest entry. This method is termed coursing. Ordinarily, if a mine is ventilated by coursing, the entire current required for one side of the mine passes down the main slope to the last entry air-course, which it follows to the last entry cross-cut. It returns by the entry to the inside curtain which throws the air into the rooms. The current then passes from breakthrough to breakthrough through the rooms back to the slope air-course, which takes it to the air-course of the entry above. Through this entry the same air is circulated as in the first entry. It then passes out to the air-course again and so on through all the entries in succession.

By coursing, no overcasts are required except the one over the main slope, but there must be a tight door at each end.

is carried in by a temporary partition reaching from beyond the last cross-cut as far in as necessary. These partitions are called brattices, and are generally made by stretching strips of canvas or brattice cloth along a row of wooden posts wedged against the roof. The cloth is very seldom tight against the roof, so that a good deal of the air leaks through and goes straight across the room. As the brattices are also generally disarranged by blasting, it is customary to make breakthroughs closer and not use brattices, except in cases where another cross-cut cannot be made because the miner in an adjacent room has not driven his room far enough ahead. The brattices are put in by the fire bosses and their helpers, who are the only persons allowed to go into a gassy room. The helpers are called "brattice men." When the entries are just starting and before the partings are complete, they are always ventilated by coursing with curtains in place of doors. Ventilation by coursing has the advantage that when the rooms are holed through from one entry to the air-course above, the fire boss and the mine foreman can pass from entry to entry without each time going out the slope air-course which is often far from the nearest of the rooms in which the miners are working. As it does no harm to continue the

rooms until they cut the air-courses above, no surveying is needed to prevent this. In a small mine a surveyor will not be necessary, a manway is more easily provided; no expensive overcasts are required, and there are no regulators to be adjusted. It is therefore easier to keep the places clear of gas by brattices, and the lamp smoke is more promptly blown out of a room. For this reason many of the miners think ventilation by coursing is better than by splitting. The coursing system, however, has



FIG. 3. SIDE OF ROOM NECK, SHOWING PROPS

the disadvantage of requiring many doors with trappers to see that they are kept closed, and the wages of a trapper for three or four months will equal the cost of an overcast. By coursing, all of the air-current has to go through the entire mine. It therefore travels much farther than if divided into splits each passing through only one entry. Also, if the same amount of fresh air is forced through a single passage instead of several combined, its velocity must be several times greater. Therefore the resistance of the air is much greater, so more power is needed to drive it, and the pressure is greater, which increases the loss by leakage through the stoppings. With straight overcast ventilation there are no unlocked doors to be left open. With coursing, on the other hand, there is danger that all the air will be cut off from the entries below if any door is left open, unless pairs of doors are used, which is not done in Arkansas.

The great disadvantage of coursing lies in the fact that the air supplied to the last entry has previously passed through all other parts of the mine, so the miners working there get the lamp smoke and impurities from all the other miners. Then if the amount of gas in the mines suddenly increases there may be enough to cause an explosion by the time the air-current reaches the light of the last miner. In case such an explosion does occur it may travel through the entire mine and not merely through the gassy split. It is for this reason that the Arkansas law requires that there be a separate split of air for each party of miners.

來 來

Sixty-five citizens of Newport recently visited Portsmouth, R. I., where they inspected the machinery, breaker, and briquet plant, of the Rhode Island Coal Co. Superintendent Johnson said that the present output was from 200 to 300 tons a day, but he expected by the use of mechanical pickers and different arrangements underground to increase this 1,500 tons a day. He also stated that he expects before fall to bring the coal into the Newport market.

Kanite Explosives

According to Charles P. Peistle, chemist of the Bureau of Safe Transportation of Explosives and Other Dangerous Articles, kanite C is in the form of a finely divided dry powder of buff color. The powder is packed in paraffined paper cartridges $1\frac{1}{2}$ in. \times 8 in., and the material examined contained organic matter so modified by oxidation, vulcanizing, or similar treatment as to be insoluble in the ordinary solvents.

The explosive was not ignited or exploded by shooting into it with a 30-caliber military rifle, but was completely detonated by a double-strength electric cap. The temperature of ignition was found to be 205° C. and the powder burned slowly and quietly when placed on a hot wood fire. It is not readily ignited, is classed as a high explosive, and is considered safe for transportation.

According to the same authority, kanite A and B ignites at 210° C. The ease of detonation was tested by placing cartridges on sand, end to end. With kanite A detonation extended from one cartridge to the next when 1 inch space intervened, but not at 2 inches. With kanite B detonation communicated $\frac{1}{2}$ inch, but not 1 inch. Neither explosive ignites or explodes on shooting into it with a 30-caliber military rifle. Both are detonated with a double-strength electric exploder. Both explosives ignite with difficulty and burn slowly and quietly when placed on a hot wood fire. These explosives are considered safe for transportation.

Kanite A is said to have passed the highest test made by the Bureau of Mines Pittsburg Testing Station for establishing permissible explosives, and to be fumeless, flameless, and smokeless, safe to handle, and not to freeze or deteriorate. It contains no nitroglycerine, chlorate of potash, gun cotton, or acids. It is insensible to concussion, friction, or ignition.

One of the advantage claimed by the manufacturer of kanite is that when dynamite is used quite a little time must



FIG. 4. MINE DOOR

elapse before the fumes clear away, and this time, taken on the total blasts fired daily, amounts to considerable in lost labor. As there are said to be no poisonous fumes with kanite explosives, the men could return to work immediately and thus the time that is usually lost while waiting for the smoke to be dispersed, often under some circumstances amounting to from 25 to 30 per cent. of the working time, would be saved.

Coal Geology of West Virginia

An Attempt to Correlate the Different Coal Beds With Those of Pennsylvania

The Carboniferous period, known geologically as the age of acrogens and amphibians, belongs in the Paleozoic or ancient life era. So far as the coal beds are concerned this period is best developed in what is termed the Eastern or Appalachian coal district. That includes Pennsylvania, West Virginia, Eastern Tennessee, Kentucky, Ohio, and Alabama.

Below the Carboniferous is the Devonian period of the Paleozoic era, known also as the age of fishes, while above is the Triassic period of the Mesozoic, or middle life, era.

For convenience, geologists have divided the Carboniferous period into three rock systems known as the Subcarboniferous, Coal Measures, and Permian.

The Subcarboniferous system includes all rocks from the Devonian to the Pottsville conglomerate, which in the anthracite fields are Mauch Chunk red shales, and in the bituminous fields the Subcarboniferous or Mississippian limestones.

The Coal Measures are divided from the Subcarboniferous upwards into Pottsville, Lower Productive, Lower Barren, Upper Productive, and Upper Barren or Permian series.

It is usual in descriptive geology to work from the oldest rocks upward, in this case from the Pottsville series which more aptly could, from structural reasons and from the methods adopted by geologists, be called Millstone-grit series outside of the anthracite fields of Pennsylvania. The Pottsville series, which is also known as Rogers No. XII, is divided into three members, upper, middle, and lower.

There seems to be no way of correlating the so-called Pottsville series of West Virginia with those of Pennsylvania, on account of the difference in the composition of the coals and the thickness of the strata. In Pennsylvania there is an approximate correlation, but not absolute, owing to the conditions mentioned varying in different parts of the state. In eastern Pennsylvania the Mauch Chunk red shale is the Subcarboniferous and is topped by a coarse water-rounded pebble rock called Pottsville conglomerate. To the west the Mauch Chunk red shale is replaced by the Subcarboniferous limestone, known also as Mississippian, and above this, corresponding to Pottsville conglomerate, is a hard gray coarse sandstone, known as "Millstone grit."

The Pottsville series, which is known as Rogers XII in Pennsylvania, where it has been thoroughly studied, is divided as follows:

- Homewood sandstone.
- Mt. Savage fireclay.
- Mt. Savage coal.
- Lower Mercer coal.
- Upper Connoquenessing sandstone.
- Quakertown coal.
- Lower Connoquenessing sandstone.
- Sharon coal.
- Sharon conglomerate.

The coal seams, like other geological formations, are named from localities where they are typically developed, consequently in new locations they receive local names at first, which are afterwards changed to the oldest geological name applied to it in print. The local name is not changed, however, until the correlation has been definitely established. It is for this reason, and in order to avoid geological confusion and economic complications, that the West Virginia Geological Surveyors are apparently moving slowly in their correlation, while as a matter of fact they are concentrating data yearly that must soon establish the exact positions of the coal beds relative to those of Pennsylvania. The coal beds assigned to the Pottsville series in West Virginia are:

- Pocahontas 1, 2, 3, 4, 5, 6, 7, 8, 9.
- Fire Creek or Quinnimont.
- Beckley.
- War Creek.
- Welsh Coal.
- Sewell or Nuttall.
- Jaeger, Hughes Ferry Coals.

The Pocahontas beds, Nos. 3 and 4, of McDowell County, and the Sewell bed, of the New River series, are the most important coal beds.

Average analyses of these coals are as follows:

	Pocahontas		Sewell	
	Coal	Coke	Coal	Coke
Moisture.....	.2300	.0900	.690	.0140
Volatile matter.....	17.4300	.9800	23.950	1.0600
Fixed carbon.....	77.7100	90.9900	72.040	91.2600
Ash.....	4.6300	7.9400	3.320	7.5400
Sulphur.....	.6200	.5800	.740	.7500
Phosphorus.....	.0057	.0061	.008	.0095

One of the earliest coals to be mined in the New River district was the Quinnimont seam. It is not yet known definitely which of the Pocahontas coal beds the Quinnimont seam represents, because the country between New and Tug rivers has not been developed sufficiently for geologists to trace the connection. Stuart M. Buck stated some years ago that he believed the Quinnimont and No. 3 Pocahontas beds to be the same.

An average analysis of the Quinnimont coal and coke is as follows:

	Coal	Coke
Moisture.....	.600	.130
Volatile matter.....	19.930	.980
Fixed carbon.....	75.200	91.710
Ash.....	4.270	7.180
Sulphur.....	.670	.640
Phosphorus.....	.035	.062

The Lower Productive coal measures are known in Pennsylvania as Rogers XIII or Allegheny River series; above the Nuttall sandstone, which forms great cliffs along New River. From Kanawha Falls to Sewell, there is a series of rocks which contain coal beds and have been assumed in a general way to represent Rogers XIII, but at the present time are termed the Kanawha series. The West Virginia Geological Survey, Vol. IIA, has divided the coals of this series into a higher and lower group. The lower group are softer than the higher group, and are higher in volatile matter than the New River coals, thus making them excellent gas, coking, and general fuel coals. The most important coal bed of the Kanawha series is the "No. 2 Gas," which is considered a split from the Campbell's Creek bed, according to I. C. White, state geologist. An average composition of the coal is given in the following analysis:

Moisture, 1.18; volatile matter, 33.52; fixed carbon, 59.78; ash, 5.52; sulphur, 1.29; phosphorus, .01.

Seventy-two-hour coke, made from No. 2 Gas coal, gave the following analysis:

Moisture, .19; volatile matter, 1.35; fixed carbon, 87.21; ash, 11.25; sulphur, .96; and phosphorus, .023.

In the following table the Allegheny series as they occur in Pennsylvania are given in the first column; the second and third columns are the writer's attempt at correlation. One difficulty in connection with the correlation of the lower productive coal beds in the Kanawha district is that the beds seem to split or divide, thus intercalating coal beds not known in other coal fields, even in the same state. This makes it fairly certain that some beds commercially valuable in one county are not so in another, owing to the thinning and thickening process undergone.

Allegheny Series	Tug River	Kanawha Series
Upper Freeport coal.....	{ Stockton Lewiston	Stockton-Lewiston-Belmont
Upper Freeport limestone..		
Bolivar fireclay.....		
Upper Freeport sandstone..	Buffalo Creek	Coalburg
Lower Freeport coal.....		
Lower Freeport limestone..		
Lower Freeport sandstone..	Thacker Alma	Winefrede Cedar Grove
Upper Kittanning coal.....		
Middle Kittanning coal.....	Warfield	{ Campbell's Creek, or No. 2 Gas, or Peerless upper divi- sion of Campbell's Creek
Lower Kittanning coal.....		
Lower Kittanning clay.....		
Lower Kittanning sandstone		
Vanport limestone.....	War Eagle	Eagle { Lower War Eagle + 660 above Sewell
Clarion sandstone.....		
Clarion coal.....		
Clarion clay.....		

The Middle Coal Measures.—These measures, while composed of the same kinds of sandstone, shale, and clay slates, as the Kanawha coal series, contain few workable coal beds and have been termed the "Barren Coal Measures," "Rogers XII," and "Conemaugh series." The important coals in this rock series are Bakerstown and Elk Lick beds, although the Brush Creek bed below the Bakerstown, and the Harlem coal bed above, have a wide distribution and in places reach a thickness where they are workable.

The Bakerstown coal is mined in Mineral County, in the North Potomac basin, and has received attention in Preston County for local consumption. It extends southwestward through Barbour, Randolph, Upshur, Lewis, and Braxton counties. The following analysis of the coal in Mineral and Preston counties show it to be high in sulphur and quite different in calorific value.

	Mineral County	Preston County
Moisture.....	.70	.8900
Volatile matter.....	15.05	29.0100
Fixed carbon.....	73.83	63.0300
Ash.....	10.42	7.0700
Sulphur.....	2.23	2.4600
Phosphorus.....	.10	.0095
B. T. U. calculated.....	13,698	15,050

The great difference in volatile matter and ash would indicate that the coal came from different places if not different beds.

Immediately below the Ames limestone is the Harlem or Crinoidal coal bed. It is at its best (2½ feet) in Preston, Harrison, and Wirt counties, where it is mined to some extent for local use. This coal is generally high in ash as the following analysis shows:

Moisture, .80; volatile matter, 27.78; fixed carbon, 54.54; ash, 16.88. There is 1.77 per cent. sulphur and .005 per cent. phosphorus.

The Elk Lick coal bed is found from 50 to 75 feet above the Harlem coal and is named from a locality in Somerset County, Pa., where it was long ago opened. It is generally present in Preston, Barbour, Upshire, Lewis, and as far south as Lincoln and Wayne counties. Elk Lick coal is mined in a commercial way to some extent, and while high in ash and sulphur, breaks into hard blocks that women use for bombarding "hawgs" and for other domestic purposes. An analysis of the coal from Lewis County is as follows: Moisture, 1.10; volatile matter, 37.40; fixed carbon, 46.46; ash, 15.04; sulphur, 2.49; phosphorus, .106.

The Little Clarksburg coal bed is about 100 feet above the Elk Lick coal. In the Fourth Potomac basin of Maryland and West Virginia it contains many impurities so it has been named the "Dirty 9-Foot." A section of this coal in the George's Creek basin 1 mile northwest of Franklin is: Coal, 2 inches; shale, 1 inch; coal, 10 inches; shale, 2 feet 3 inches; coal, 2 feet 9 inches. Total 6 feet 1 inch.

About 65 feet above the Little Clarksburg is the Little Pittsburg coal seam. Neither of these beds is worked at present in West Virginia, and as an analysis would approximate 50 per cent. ash unless the coal was cleaned, none have been reported.

The thickness of the Conemaugh series varies from 495 to 595 feet between the Upper Freeport of the Allegheny series and the Pittsburg bed of the Monongahela series. Sedimentary rocks are found about 35 feet below the Ames limestone, termed Pittsburg red shale. These red beds of the Conemaugh, I. C. White says, were deposited as red muds, and are not the oxidized rocks found in places in the coal measures. No other red beds are to be found in the coal measures, in fact where red shales of the Mauch Chunk formation, or red shales of the Permian formation are found, coal is wanting. Le Conte states in his geology that when iron ore is diffused as a coloring matter in earths there has been no organic matter to leach and accumulate it as an ore deposit. A section of the Lower Barren measures with the nomenclature of Pennsylvania, Maryland, and West Virginia with the approximate distance between the beds in feet follows:

Lower Pittsburg sandstone, Pennsylvania and West Virginia, below the Pittsburg bed and about the Upper Freeport bed.

Pittsburg limestone, Pennsylvania.

Little Pittsburg coal, 80 feet below the Pittsburg bed and 515 feet above the Upper Freeport.

Connellsville sandstone, Pennsylvania.

Little Clarksburg coal, Pennsylvania and West Virginia; Franklin and Dirty 9-Foot, Maryland; 150 feet below the Pittsburg bed and 445 feet above the Upper Freeport.

Clarksburg limestone, Pennsylvania and West Virginia.

Morgantown sandstone, West Virginia.

Elk Lick, Crinoidal or Barton, Pennsylvania and West Virginia; 250 feet below the Pittsburg bed and 345 above the Upper Freeport.

Elk Lick limestone, Pennsylvania.

Birmingham shale, Pennsylvania.

Ames limestone, Pennsylvania and West Virginia; about midway of the Lower Barren measures, 292 feet between Pittsburg and Freeport coal beds, and about 100 feet above the Pittsburg red shale.

Harlem coal, West Virginia and Pennsylvania; not generally more than fireclay, 280 feet above the Freeport and next above the Pittsburg red shale. Not recognized in Maryland although the Maynadier slate seam is in its horizon.

Pittsburg red shale, Pennsylvania, West Virginia, and Maryland; about 100 feet below the Ames limestone and about 192 feet above the Upper Freeport.

Saltsburg sandstone, Pennsylvania.

Barkerstown coal, West Virginia and Pennsylvania; synonymous with "Three or Four Foot," "Honeycomb," and Barton of Maryland. About 180 feet above the Upper Freeport coal.

Pine Creek limestone.

Buffalo sandstone, about 8 feet below Barkerstown coal and from 80 to 98 feet thick.

Brush Creek limestone.

Brush Creek coal, about 67 feet above the Upper Freeport and the lowest coal bed in the Barren measures.

Upper Mahoning sandstone.

Mahoning coal, Pennsylvania. Not recognized in Maryland and West Virginia.

Lower Mahoning sandstone.

The Upper Productive Coal Measures.—These measures, known as Rogers XV and Monongahela River series, have as the lowest member the celebrated Pittsburg coal. West Virginia, is supposed to possess an area of 1,100,000 acres of this valuable coal, averaging more than 8 feet in thickness. Pittsburg coal has a specific gravity of about 1.275, thus making an acre of coal 1 inch thick weigh 144 tons, or 1 foot thick weigh 1,728 tons. An average of 95 analyses of this coal in West Virginia is as

follows: Moisture, 89; volatile matter, 38.52; fixed carbon, 53.55; ash, 7.04; sulphur, 2.18; phosphorus, .012.

This Pittsburg coal is much higher in sulphur than the same bed in Maryland and Pennsylvania.*

At approximately 40 feet above the Pittsburg coal is the Redstone coal, which appears to have a wide distribution in Lewis and Gilmour counties. The Redstone coal so closely approximates the composition of the Pittsburg bed, it has sometimes been taken for it. From 60 to 80 feet above the Redstone coal is the Sewickley coal bed. This coal is separated by thin partings of mother coal or mineral charcoal into two benches. For domestic use it is preferred to Pittsburg coal, because even although it is higher in sulphur the ash is less fusible and produces less clinkers. The coal covers a wide area in West Virginia, as it is found in Monongalia, Marion, Mineral, Ohio, Brooke, Hancock, Marshall, and Wetzel counties.

About 180 feet above the Sewickley coal is the Uniontown coal bed, which is mined for local use by farmers in Gilmer, Lewis, Calhoun, and Roane counties.

The Waynesburg coal bed is at the top of the Upper Productive series at about 330 feet above the Pittsburg bed. This coal has economic value in Marshall, Monongalia, Ohio, and Wetzel counties. An average analysis of the coal is as follows: Moisture, 2.10; volatile matter, 32.4; fixed carbon, 51.24; ash, 14.26; sulphur, 2.7.

The Waynesburg coal varies considerably in composition and thickness according to the locality from which it comes. It is also separated by a band of fireclay, therefore taken as a mining proposition at the present time it belongs to the coals suited to conservation.

The following is a section of the Upper Productive coal measures:

Waynesburg coal, thickness from 6½ to 9½ feet with fireclay parting. Known in Pennsylvania, Maryland, and West Virginia by same name, 330 feet above Pittsburg bed.

Little Waynesburg coal 6 inches to 12 inches.

Waynesburg limestone.

Gilboy sandstone.

Uniontown sandstone.

Uniontown coal, 3 feet to 4 feet 6 inches; 180 feet above Pittsburg bed, Pennsylvania and West Virginia.

Uniontown limestone.

Fulton green shale.

Benwood limestone.

Sewickley sandstone.

Upper Sewickley coal, 2 foot 8 inches, Pennsylvania and West Virginia; known as Tyson and Gas in George's Creek, Maryland, 110 feet above Pittsburg bed.

Lower Sewickley coal, 3 feet 4 inches, Pennsylvania and West Virginia; known as Tyson and Gas in George's Creek, Maryland, 110 feet above Pittsburg bed.

Sewickley limestone.

Redstone coal, about 5 feet thick; name the same in Pennsylvania, Maryland, and West Virginia, about 40 feet above the Pittsburg bed.

Upper Pittsburg sandstone.

Pittsburg coal, 8 feet 8 inches, West Virginia and Pennsylvania; synonymous with Big Vein of 14-foot bed; Elk Garden bed, Maryland.

The Upper Barren, Permian, Rogers XVI, or Dunkard Creek series, of Pennsylvania, contain but one coal bed of moment, and that is the Washington. This varies from 13.13 per cent. to 25.6 per cent. in ash, from 1.64 to 9.75 in sulphur, and is not much in demand. The remaining coal beds in the Dunkard Creek series vary from 12 to 18 inches in thickness and are therefore adapted to conservation. According to the names first adopted by Professor Lesley, of the Pennsylvania Second Geological Survey, the Washington County group, from the Waynesburg coal bed to the Jollytown coal bed, was numbered

XVI, and the Green County group, from the Jollytown to the Proctor sandstone, was numbered XVII. The total thickness of the Barren measures XVI and XVII is about 1,200 feet. A vertical section of Rogers XVI taken by I. C. White in Greene County, Pa., is appended.

DUNKARD CREEK, GREENE COUNTY, PA. No. XVI ROGERS

	Feet	Inches	Feet	Inches
1. Concealed from top of Shough's knob.....	165			
2. Sandstone, massive, Gilmore.....	40			
3. Shales, with limestone at base.....	15			
4. Sandstone and shales and concealed.....	100			
5. Shale, red.....	2		480	
6. Shales, gray.....	20			
7. Shale, marly.....	2			
8. Sandstone and shale.....	35			
9. Shale, red.....	3			
10. Sandstone and shale.....	50			
11. Red shale.....	3			
12. Shales and sandstone, Nineveh.....	25			
13. Shales.....	20			
14. Coal, Nineveh.....	1	6		
15. Shales.....	25			
16. Limestone (No. X), Nineveh.....	7			
17. Shales, sandstone and concealed.....	100			
18. Sandstone, massive, Fish Creek.....	20			
19. Shales with fossil plants.....	10			
20. Coal, Dunkard { Slate 0' 1" } { Coal 0' 1" } { Coal 0' 6" }	1		223	
21. Limestone.....	1			
22. Sandstone.....	10			
23. Shales.....	17			
24. Limestone, Jollytown.....	1	6		
25. Shales and sandstone.....	25			
26. Coal, Jollytown.....	1	1		
27. Calcareous shale, fossiliferous, fish teeth.....		6		
28. Limestone, Upper Washington.....	4			
29. Shales and sandstone.....	115			
30. Limestone, Middle Washington.....	3			
31. Shales.....	40			
32. Sandstone.....	35			
33. Shale.....	5		276	8
34. Coal, Washington "A" { Coal, impure 1' 2" } { Fireclay 2' 6" } { Coal 0' 6" }	4	2		
35. Shales and sandstones.....	60			
36. Limestone, Lower Washington.....	5			
37. Shales.....	5			
38. Coal, Washington, slaty.....	5			
39. Shales and sandstones, including a coal bed near center.....	110			
40. Coal, Waynesburg, "A".....	2	6	182	6
41. Shales.....	10			
42. Sandstone, Waynesburg.....	50			
43. Shales, with fossil plants (Cassville).....	5			
44. Waynesburg coal.....				
Total.....			1,162	3

栗 栗

Coal for Spain

A company was in process of formation in the United States some months ago, says U. S. Consular Report, for exporting American coal to Spain, France, and Italy, the idea being that it could undersell English coal in these markets provided the fleet of ships, which it was proposed to build for this purpose, could be assured of return cargos. Agents were sent to Spain for the purpose of ascertaining the possibility of making contracts with the iron miners of the country to supply a sufficient quantity of iron ore for return freight to the United States, and it was understood that the ore could be furnished in any quantity, but up to the present it is not known if the company in question has taken any steps to put its enterprise in operation.

The consumption of coal in Spain in 1908 amounted to 6,336,921 tons, of which 4,118,276 tons were Spanish coal and 2,218,645 tons imported. The amount of pit coal used for coking purposes in 1908 was 644,727 tons, from which 477,059 tons of coke were produced.

Prices of Cardiff steam coal in cargoes, c. i. f. Barcelona, are as follows per ton: Large, \$5.71; small, \$3.54. The price of Asturian coal, f. o. b. Barcelona, is as follows per ton: Large, \$6.56; middle-sized, \$6.17; siftings, mixed with crushed coal, \$4.82.

* See West Virginia Bulletin Two, 1911, Levels' Coal Analyses, page 327.

Mine Explosions From Natural Gas Well

Description of Two Explosions that Were Caused by Gas Escaping From a Well into Mines

*Bu C. H. Tarleton**

On December 19, 1910, the officials of the Consolidation Coal Co. were called upon to face a disaster resulting from a gas well, and, as is usually the case, the trouble came from an unexpected source. About 6:50 A. M., an explosion occurred in Consolidation No. 47 mine, which caused the death of three men, and completely wrecked one section of the mine. On the same date, about 4:50 A. M., Consolidation No. 49 mine was badly wrecked and set on fire by an explosion, but fortunately no lives were lost. Eventually both explosions were found to have been caused by natural gas escaping into the mines through the pavement or bottom, from a gas well located over and drilled through a pillar of coal in mine No. 47.

Mine No. 47 is located about 8 miles south of Fairmont, W. Va. The opening to mine No. 49 is about 1 mile by railroad from No. 47, but the workings are adjacent to each other. Both mines are drift openings and are operating the Pittsburg seam. Mine No. 47 was opened in 1899, and previous to December 19, 1910, there had never been a trace of explosive gas detected in it. Mine No. 49 commenced operation in 1897, and with the exception of some slight traces in clay veins in the farthest advanced workings, no explosive gas had ever been detected in it. In the last year or two, numerous oil and gas wells have been drilled through or near the mine workings.

These wells were always located so they would pass through solid coal and where it would be possible to leave a block of coal of what would be considered ample dimensions to protect the mine and the well. It was generally thought that there would be no particular danger from these wells until the time arrived for extracting the coal around them. For this reason no one was expecting the occurrence on the morning of December 19.

On the date mentioned, the miners at mine No. 47 started to their work as usual. Some of them had already reached their places, while others were on the main heading, when an explosion occurred that threw them down and rolled them quite a distance along the heading, but aside from being slightly bruised and badly scared, those on the main heading were uninjured, and were able to make their way to the outside. The fan was running as a blower, but was immediately reversed and a rescue party organized and started in the mine. It was soon discovered that the explosion had occurred on the first south face, and had not extended beyond this immediate section. The men beyond this section were able to leave the mine through an opening on the No. 3 south face and through an opening to mine No. 36, thus avoiding the afterdamp.

While the necessary arrangements were being made to restore the ventilation on first south face, a census was taken and all men accounted for, except five. By this time the rescue party was able to advance and explore the first south face. A body was found at the neck of No. 2 room, second butt, and two more at the junction of the third butt. All were badly burned and a statement of one of the doctors who made a post-mortem examination of one of them was to the effect that death was caused by inhalation of flame. After the exploration of the second and third butts, and the discovery of the three bodies, it was thought that the other two were on first butt. This heading was longer than the others and the men were supposed to be a considerable distance from the bottom; it seemed a certainty that they would be dead. For this reason and from the fact that there had been considerable gas and some smoldering fire on the other headings, it was not

thought advisable to act hastily in restoring the ventilation on this heading. The company's oxygen apparatus had been sent for, and was expected any minute. With its arrival, it was the intention to explore the heading before any air was permitted to enter. While these arrangements were being made, a very happy incident occurred which, however, illustrates one of the great dangers to which a rescue party is subjected while exploring a mine. A start had not yet been made to enter the heading when two lights were noticed near the top. It was quickly ascertained that the lights were on the heads of the two men that were being sought and that the men were coming out. A stopping had been blown from a cross-cut through the barrier pillar, enabling them to pass to the main heading, thus unconsciously avoiding the gas, preventing a second explosion that probably would have killed all present. These men, who were foreigners, stated that when the explosion occurred, they supposed it was a heavy shot in the adjoining room. When the afterdamp reached them, they left their working place and passed up the heading to where there was a door that had not been wrecked. Finding the air fresh on the other side of this door, they remained there until they got tired waiting for the driver, when they started out to find why he did not come.

When an entrance was gained to the first south face section, large bodies of standing gas were encountered at second and third left butts, and on the sixth right butt. This gas was being liberated through the pavement and could be heard boiling and seething through the water for a long distance, a near approach made it possible to detect the gas with the lamp. Later on it was found that these blowers occurred in almost a straight line from a gas well located in the barrier pillar between first south face heading and room No. 1 off second left butt, the line extending in a southwesterly direction, parallel to the contour lines of the Pittsburg coal seam, to a point in mine No. 49 about 2,300 feet distant from the well. On account of the very pronounced odor of the gas, it was surmised that it was coming from a gas well, and the well mentioned above, being the nearest one to the affected area, was naturally suspected as being responsible. As soon as the necessary arrangements could be made, or about 9 P. M., on December 19, the valves on this well were opened, and immediately thereafter the gas blowers in both mines began to recede.

The explosion in mine No. 47 was evidently caused by the miners on first south face coming into contact with the gas with their open lights. It could not be definitely determined which one of the men fired the gas, but in all probability it was one of those found at the entrance to third left butt. These men had passed the point where the gas was being liberated and, it seemed, had been in the act of shifting their car to their working place, where there undoubtedly was a body of standing gas. The explosion in this mine was not violent, and from the indications, extended but a short distance from the point of origin, due in all probability to the fact that there was not sufficient air at that point to dilute the entire amount of gas to an explosive mixture. This belief is substantiated to some extent by the fact that a large amount of standing gas was found in that section of the mine by the first men reaching the scene soon after the explosion.

It has been proved that the circulation of large volumes of air through a mine in cold weather will carry out the moisture, thus creating a dangerous condition from dust. For this reason, and mine No. 47 being a non-gaseous mine, the fan was run only when the mine was in operation. Although the fan had been idle for a period of 36 hours, and to within about 1 hour previous to the accident, it is not thought that this fact had any immediate significance in connection with the explosion. From calculations, it was estimated that the time necessary for air entering at the fan to travel the entire distance of the split which passed the affected area and return to the outside, was about 38 minutes. Assuming that these calculations were approximately correct, the air, after the fan was started on the

* Superintendent of Mining, West Virginia Division, The Consolidation Coal Co., Fairmont, W. Va. Paper read before West Virginia Mining Institute.

morning of December 19, would have had almost enough time to make two complete circuits around the split, in which event it is reasonable to assume that it had sufficient time to carry away any gas directly in its path. No provision had been made, however, for circulating the full volume of air to the working faces, it not being required or considered necessary in a non-gaseous mine, consequently the air-current would not have removed any gas that might have collected in tight ends or places where the ventilation was light. With the gas blowers in this mine located in just such places as described, one of them being in a tight end, and several others in places where the ventilation would be light, without special arrangement being employed to conduct the air into them, it is not unreasonable to believe that conditions would have been practically the same had the fan been running continuously.

The above statement can be strengthened somewhat by the following: It has already been said that the fan was operating as a blower; as a result, the miners entering the mine traveled against the air, even as far as the end of first south face, where the explosion occurred. The two men, found at the entrance to third left butt, who have been mentioned as probably firing the gas, passed by some of the heaviest blowers in the mine to a point 100 feet or more beyond where they were found, in the direct path of the current of air supplying this section of the mine. The inference to be drawn from this fact, is that the gas directly in the path of the air-current was being swept away, and that the amount was not sufficient to render the air-current explosive; but as soon as the men left the main volume of air, and reached a point where the ventilation was lighter, they came in contact with an explosive mixture which was fired from their open lights. This being true, it is reasonable to assume that the same conditions could have existed, as has been stated, with the fan running continuously.

The explosion in mine No. 49 was set off by the night pumper, who was the only man in the mine at the time. He was not seriously injured. According to reliable information, he entered the mine on the evening of December 18, and sometime near 8 P. M., came in contact with some gas blowers in rooms Nos. 10 and 11, on third right butt off main south face, the blowers being ignited from his open light. After considerable trouble, he was able to extinguish the flames with his coat, after which he continued at his work, not thinking it important to report the matter to the officials at once, but deciding to wait until morning; this, of course, was a bad mistake and one that might have caused a more serious disaster, but was due to his lack of previous experience with gas in that mine. He attended the pumps in the same section of the mine until nearly 5 o'clock in the morning of the 19th, at which time he started into third face heading to throw an electric switch which was located a short distance from the main heading and beyond an overcast at the intersection of first butt off third face. When directly under the overcast, and before he had reached the switch, he came in contact with a body of gas that must have extended throughout that section. The gas was ignited from his open light, causing an explosion with apparently little violence at the point of ignition, but from indications, accumulating tremendous force farther in the mine. The gas evidently burned rather than exploded for some distance, when the flames probably encountered a mixture of gas and air more nearly the correct proportion, where a violent explosion took place.

On account of there being little force at the initial point of the explosion, the pumper was not seriously injured, beyond being slightly burned, and about the only other damage done at that point was a partial wrecking of the overcast; the latter no doubt saved the pumper's life, since the damaging of the overcast caused a short-circuit of the air at that point, the ventilating system from there to the pit mouth and fan having been little disturbed. This allowed a supply of fresh air to reach him, which of course kept the gases away. As soon as the afterdamp was cleared sufficiently from the main heading,

parties from the outside entered the mine, found the pumper, and took him out.

The fan at mine No. 49 as at No. 47, was operating as a blower. The only difference in connection with the operation of the two fans was that with the exception of about five hours on the 17th, the fan at No. 49 had been running continuously. This was thought to be another good reason for assuming that the explosion at mine No. 47 would have happened just the same if the fan there had been running continuously. The fan at mine No. 49 was reversed before any extensive exploration was arranged for. When arrangements were completed, a party of mine officials and others, properly equipped with the necessary tools and material for restoring the ventilation, entered the mine. When they had made their way into the third face, gas blowers were found coming through the pavement in several different places, and a fierce fire was burning in room No. 5 on first left butt. It was the general opinion that some of the gas blowers were fired by the flames and continued to burn, thus firing the coal.

The fire in room No. 5 extended from the first to the second cross-cuts and was burning fiercely when it was first reached. It was soon realized that it would be useless to undertake to fight this fire with the means at hand. Work was commenced at once to seal it off and prevent it spreading to other sections of the mine. To do this necessitated the building of eight stoppings. Work was commenced at the first cross-cut on the intake of the air, and continued without any serious trouble around until the last one was reached, which of course was the most difficult one to close. The stoppings were first built with canvas, quickly reinforced with wood and plaster, and at the same time a force of men was started to build substantial concrete stoppings against the wood. By this means the fire was confined to four rooms on the heading mentioned, the rooms being Nos. 5, 6, 7, and 8.

In sealing off the fire, it was necessary to enclose with it at least one large gas blower, and in all probability there were several others within the enclosed area. At first it appeared that it would be dangerous to enclose this gas with the fire, but since there were no effective means at hand with which to fight it, and nothing being known of conditions beyond to where it was rapidly spreading, there was no choice but to take chances and seal it off as quickly as possible. Immediately after sealing off the fire, it began to die and become quiet. The action within the enclosed area was noted by means of a piece of 2-inch pipe inserted in one of the stoppings on the end of which pipe was a valve to permit its being opened and closed.

From the initial point described, the explosion seemed to travel in a general course toward and to an air-shaft located along the main face heading, about 300 feet beyond on third left butt. The greatest damage to the mine was done on second left butt off third face, and third and fourth right butts off the main heading. All of the places mentioned were in the direct path of the explosion from its point of origin to the air shaft. Nearly all stoppings and overcasts along the main heading were of brick or concrete construction, and were all destroyed in the section covered by the explosion. Electric wires were twisted and coiled into nearly every conceivable shape, mine cars were wrecked, some of them being blown from their positions in the rooms up on to high piles of coal and roof falls, but little damage was done to any of the mine beyond the fourth left butt and the air-shaft. Had it not been for this air-shaft and the excellent condition of the mine relative to humidity, the dust being well saturated, the explosion would no doubt have traversed the entire main heading to the back end of the mine, and the rebound or backlash from that point would have continued in all probability to the pit mouth, branching out on its way into the headings to the right and left, and wrecking the entire mine.

In both mines careful attention had been given to the prevention of accumulation of dust. This was accomplished by

the introduction of moisture in the mine air by means of steam, and in addition to that, the careful and systematic spraying with water of any part of the mine showing the least tendency to become dry. Had it not been for the good conditions resulting from such precautions, or had the mines not been wet or damp, it is believed the statement will not admit of doubt that the explosion of gas would have been propagated and reinforced by dust, with the result that both mines would have been completely wrecked as well as the mines connected with them.

It was said in the beginning that the cause of the explosions described was a gas well located over and drilled through a barrier pillar in mine No. 47. The reasons for that conclusion are briefly as follows: First, both of the explosions were undoubtedly caused by gas; second, previous to December 19, 1910, no explosive gas had ever been detected in mine No. 47, even by chemical analysis of the air, during its entire history, and with the exception of the blower reported to have been ignited by the pumper on December 18, only a slight trace was ever detected in mine No. 49, this being liberated from clay veins at the face of the main heading, which is in a different section of the mine from where the explosion occurred, and which was not affected by it; third, the gas discovered had an odor resembling gasoline, benzine, or naphtha, which odor is not peculiar to marsh gas or methane as commonly met with in coal mines, but which odor is present in the case of gas produced from a gas well; fourth, samples of gas from the well, and also samples from the blowers in both mines, were analyzed, the analyses of the different samples having an uniformity and bearing a close relation to each other; also the analyses of the samples taken from the blowers in the mines showed them to contain a percentage of ethane, a gas which is rarely, if ever found in coal mines from natural causes; fifth, after the well had been opened up, and given free vent to the outside, the gas blowers in both mines began to diminish until the greater number of them entirely disappeared.

The analyses of the samples mentioned are as follows:

ANALYSES BY WEST VIRGINIA GEOLOGICAL SURVEY

	From Sturm Well Dec. 23, 1910 Per Cent.	From Mine No. 49 Dec. 29, 1910 Per Cent.	From Mine No. 49 Dec. 22, 1910 Per Cent.
Carbon dioxide.....		.35	.70
Oxygen.....		.70	5.90
Methane.....	86.90	88.60	68.40
Ethane.....	12.70	7.30	2.76
Nitrogen.....	.40	3.05	22.24

ANALYSES BY PITTSBURG TESTING LABORATORY

	From Sturm Well March 15, 1911 Per Cent.	From Mine No. 47 March 15, 1911 Per Cent.	From Mine No. 49 March 15, 1911 Per Cent.
Carbon dioxide.....	.30	5.70	1.60
Oxygen.....	.20	.90	1.10
Illuminants.....	.20	.10	.10
Methane.....	86.05	78.84	74.97
Ethane.....	12.35	9.00	12.07
Nitrogen.....	.90	9.46	10.16

The manner in which the well was closed, it is believed, was responsible for the gas escaping into the two mines. At its completion, 2-inch tubing, Fig. 1, was inserted in the well with a wall packer *g* placed above the Bayard sand; another packer *e* was also placed around and near the bottom of the 5 $\frac{3}{16}$ -inch casing *f* above the 50-foot sand. A Braden head *b* was used on the well, which was attached to the 8 $\frac{1}{4}$ -inch or outside string of casing, thus closing off any vent to the outside, and making impossible the escape of any leakage of gas outside of the inner strings of casing. Fig. 1 shows about the manner in which the well was closed. Should anything have happened to the packer on the 2-inch tubing, or to the tubing itself, causing it to give

way or leak, the gas would have escaped up around the outside of this tubing to the top of the hole or to the Braden head, when it would pass over the top of the 5 $\frac{3}{16}$ -inch and 6 $\frac{1}{2}$ -inch casing *d* and down along the inside of the 8 $\frac{1}{4}$ -inch or outside casing, to the bottom of the same, below which point the entire pressure of the well would be directed against the bare walls of the hole, and where there undoubtedly was an opening or crevice of some kind that allowed the gas to escape into the mines. On February 8, 1911, the 2-inch tubing and the packer were removed from the well. No defects were found in the tubing, but the packer was entirely stripped of its rubber. As to whether the rubber was taken off in pulling the packer from the hole or not could not be determined.

An injury to either the packer or tubing might result from any one of many possible causes. It might be due to the natural and constant rock pressure of the well, or to the settling of the block of coal around the well. Such settling could be caused by the disintegration of the fireclay beneath the coal on account of open entries and rooms surrounding the block, thus permitting the action of the air and water on the fireclay strata mentioned. It is not impossible or improbable that the mining of pillars in proximity to the block of coal would cause a settling or a disturbance of the same, although the block itself, which was 380 ft. x 135 ft. in dimension, had not been touched since the well was drilled, which was March and April, 1910. The covering over the coal at this point is 176 feet, with a strong sand rock immediately above the roof slate. On account of this heavy sand rock, roof breaks are sometimes difficult to make and the effects from mining may be seen a considerable distance away from where any coal is being removed.

In this connection, it may be stated that a fresh break occurred in the surface near the well, at or near the time of the explosion. The break was over territory where the pillars had been drawn for some time, indicating that the strata over the coal were probably throwing an extra amount of weight on that particular block of coal before the break occurred.

After the explosions, all of the 2-inch tubing and the 5-inch casing was pulled from the well and inspected. The well was then recased in the same manner as described above, new packers being used, but the Braden head was placed on the 5-inch casing, leaving an open vent for all gas that might escape around the 5-inch casing between the 5-inch packer and the

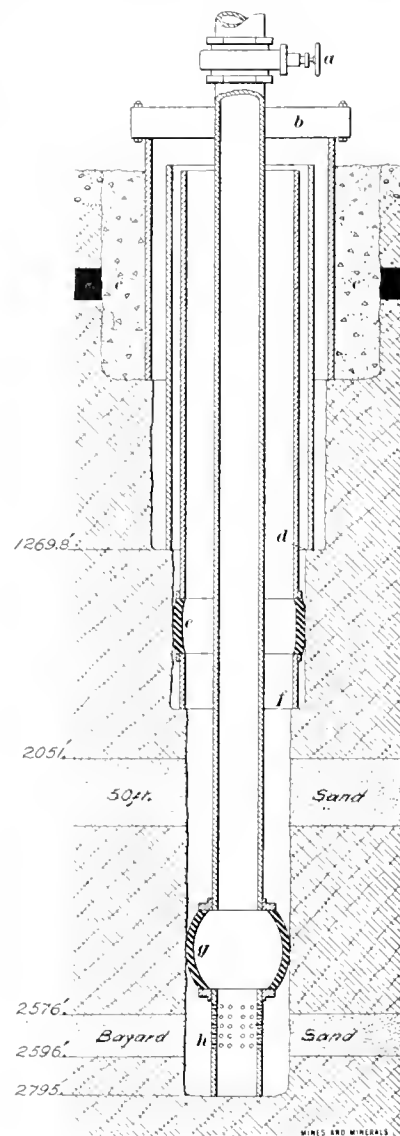

FIG. 1

top of the hole. The valves on both the 2-inch tubing and the 5-inch casing were closed on March 21, 1911, but no perceptible increase was found in the blowers inside the mines.

The writer has attempted to give the principal facts in connection with the explosions described, and sufficient evidence to prove beyond any reasonable doubt that the cause was the gas well mentioned. If this paper tends to impress more forcibly upon mine operators, managers, and engineers the importance of accurate location of all oil and gas wells, of protecting them by the best methods to be devised, and of employing the proper method in closing such wells, he will feel that he has contributed, at least in a small way, something toward the welfare of the men who toil underground.

采 采

Tennessee Coal Production

The following table shows coal product and values of Tennessee coal mines in 1910 by counties, also disposition of product and average value per ton obtained:

Coal product and values, disposition of product, and average value per ton obtained in 1910.

County	Coal Product (Short Tons)					Coal Values	
	Loaded for Shipment	Used for Fuel and Steam	Sold Local Trade and Employes	Coked	Total Product	Total Value	Average Value Per Ton
Anderson.....	783,630	13,889	4,555		802,074	\$ 834,149	\$1.04
Bledsoe.....	27,500	200	300		28,000	30,800	1.10
Campbell.....	1,655,257	33,015	19,397	8,896	1,716,565	2,016,181	1.17
Claiborne.....	1,592,499	18,385	2,532		1,523,614	1,527,729	1.00
Cumberland.....	48,643	1,135	202		49,980	56,375	1.13
Fentress.....	96,114	2,734	189		99,037	106,857	1.09
Grundy.....	320,868	1,571	1,776	32,995	357,210	393,212	1.10
Hamilton.....	193,853	7,707	7,706	68,853	278,119	320,975	1.15
Marion.....	492,156	9,663	4,797	41,300	547,916	692,421	1.26
Morgan.....	385,216	11,218	2,627	105,985*	505,046*	482,180	.96
Overton.....	77,156	914	265		78,335	77,791	1.00
Rhea.....		3,811	9,120	153,965	148,896	208,976	1.40
Roane.....	5,481	10,654	3,000	175,264	194,399	234,035	1.20
Scott.....	128,020	2,200	2,457		132,677	158,986	1.20
Sequatchie.....	35,134	2,133	852	46,067	84,186	93,445	1.11
White.....	344,965	15,428	2,439		362,832	392,728	1.08
Total.....	6,096,492	134,657	62,214	615,325	6,908,688	\$7,626,840	\$1.10

* The product of the State operations of Brushy Mountain mines, at Petros, amounted to 333,693 short tons, valued at \$307,564 or 96 cents per ton. The product of Morgan County excluding the operation of the State mines amounted to 171,407 short tons, valued at \$174,616 or \$1.02 per ton.

Appointment of Ohio Mine Inspectors

Since first elected governor, the attitude of Governor Harmon toward the mining interests of the state and his determination to make the Mining Department non-partisan and free the inspectors from any undue political influence, has given the very strongest evidence of his broadmindedness, as well as his keen interest in seeing that the best possible service is secured from state appointees whose duty it is to see that the lives and property of its citizens are properly cared for by a judicious application and enforcement of its laws.

In accordance with the law and with the approval of Governor Harmon, George Harrison, chief inspector of mines, made the following appointments in the Department of Mines:

Second District.—Composed of the counties of Hocking, Meigs, and a portion of Athens and Gallia, Edward Kennedy, Carbon Hill, Hocking County, Ohio, for a term commencing July 1, 1911, and ending June 30, 1914.

Third District.—Composed of the county of Athens, John L. McDonald, Glouster, Athens County, Ohio, for a term commencing July 1, 1911, and ending June 30, 1914.

Sixth District.—Composed of the counties of Coshocton and Tuscarawas, Alex Smith, New Philadelphia, Tuscarawas County, Ohio, for a term of three years, commencing July 1, 1911, and ending June 30, 1914.

Seventh District.—Composed of the counties of Holmes,

Medina, Ottawa, Portage, Stark, Summit, Trumbull, and Wayne, W. H. Miller, Massillon, Stark County, Ohio, for a term commencing July 1, 1911, and ending June 30, 1914.

Eighth District.—Composed of a portion of both Belmont and Jefferson counties, Lot Jenkins, Martins Ferry, Belmont County, Ohio, for a term commencing July 1, 1911, and ending June 30, 1914.

采 采

Obituary

FRANCIS M. OSBORNE

Mr. Francis M. Osborne, of Cleveland, Ohio, one of the leading coal-mine operators in the Middle West, and prominent in a wide range of business ventures, died on the 16th ult., at a Toledo, Ohio, hospital, where he had been taken after having collapsed on a Lake Shore train while en route from Cleveland to Chicago.

E. W. MARPLE

E. W. Marple, who has been paymaster of the Lehigh and Wilkes-Barre Coal Co. practically since its organization, died in Wilkes-Barre, July 9. Mr. Marple was a veteran of the Civil War and took an active interest in local affairs.

Iron Sprag at Radiant Mine

An effective sprag used on the tippel at the Radiant mine of the Victor American Fuel Co., near Florence, Colo., is shown in the accompanying sketch. The dimensions may be altered to suit the ideas of the maker. It is made of ordinary round iron, the diameter of which will naturally depend upon the size of the car and its consequent loaded weight. Aside from the fact that these sprags never wear out, they possess a great advantage in the ease with which they may be released. This latter is an important point where cars are being spragged into a dump. When properly used the wear upon the car appears to be little, if any, more than with wooden sprags. J. Q. McNatt is the originator of this sprag.

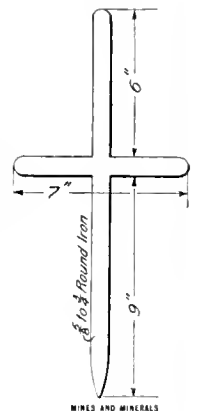

采 采

The water gauge or pressure produced by a fan varies directly as the square of the speed. If a fan is running 80 revolutions per minute and produces 1-inch water gauge, what pressure will it produce at 160 revolutions per minute? Stating the proportion thus: (80)²: (160)²: : 1 inch : x, we have x = 4-inch water gauge.

Lessons To Be Learned From Mine Fires

The Important Influence of Powerful Ventilating Currents in Spreading Fires in Mines

At a recent session of the Mine Inspectors' Institute, the following paper was read by John Verner, Mine Inspector, of Chariton, Iowa:

The value of a lesson of a mine disaster to be of practical use as a guide for devising means of prevention of a possible occurrence of similar nature does not depend on painting the calamity in vivid colors or in giving in harrowing detail all the suffering and horrors caused by it or in heaping blame, deserved or otherwise, on state and mine officials, but rather on a careful, fair, and full inquiry by competent men, including miners, into all the causes of the disaster, and a well-considered presentation of the influence of each.

After the Cherry fire nearly all these things were done, but there was evidently one mistake made that, in my judgment, impaired the future value of the disaster's lesson materially. While the presence of the torch with its burning drops of oil falling on the hay was given a prominent place as the main cause of the fire and was denounced as a great menace and blunder, although the use of such torches at shaft bottoms was fairly general in the mines of this country, the fact that the great draft playing on the incipient blaze was really the most powerful and determining cause in this great disaster was almost entirely ignored. Had this feature of the Cherry lesson, showing the influence of a great draft passing through the shafts and entries as through a large blowpipe, forcing the rapid development of a small initial flame and producing the most intense concentration of heat, been given the prominence and emphasis it deserved, so its import could have been correctly appreciated and understood by mine managers and mine employes, it is probable that, had the knowledge so gained been put to proper use in the Delagua and Pancoast mines, the great loss of life in them would not have occurred. Miners and men in charge of mines generally see only the beneficial effects of a strong air-current sweeping through the underground passages and workings, and they do not realize as they should, that while ordinarily a large air volume is highly desirable and necessary as a health and safety promoting agency, in conjunction with even a very insignificant blaze, it becomes the most potential force in the destruction of life.

The Delagua mine fire, that first killed 33 men by smoke and then caused a dust explosion killing 46 more, was evidently started by a piece of smoldering lamp cotton or by burning tobacco thrown away by one of the number of drivers who had been eating their dinner in the return end of a cross-cut closed by an unused door. A large volume of air was passing along the intake and its pressure on the door was considerable, with the result that jets of air were driven with great force through the cracks under and around the door from the intake into the return and the smoldering fire. Under the forceful impinging of the air the fire gained rapidly, and as soon as it had partially destroyed the door the air was short-circuited, the cross-cut and vicinity became a roaring furnace, the air rushing into it with such great force as to violently stir up the coal dust and carry it to the fire in such quantities as to cause the subsequent explosion. This disaster would not have occurred if the driver, who passed the cross-cut after the men had left it and who noticed some smoke there, had stopped and put out the yet insignificant fire. No doubt this driver had read or heard all about the sensational features of the Cherry calamity, but his reprehensible and culpable neglect to investigate and promptly extinguish the fire showed that he knew nothing of the instructive features of the Cherry lesson. It is possibly unjust to condemn this man too severely, and a large share of

the moral responsibility for the accident must be assumed by the mine management, if it can be shown that the management, with a great lesson before it, neglected to profit by it and failed to make such preventive plans and arrangements as the lesson may suggest.

The fire in the Price-Pancoast colliery started in an underground engine room while the engineer was temporarily absent, and its exact cause has not been established. A brisk air-current was passing through the engine room. The management of the mine evidently recognized the possible danger from fire, for pipe lines were laid to different parts of the workings to provide a ready water supply in case of need and a tap was placed in the engine room. The arrangement, however, while commendable in a general way, proved not as effective for checking the fire as it should have been. A tap with hose attached located at the center or on the return end of a mine stable where the air flow is always in the same direction, with the air entering at one end and going out at the other, would be useless in fighting a fire that had started near the intake of the stable, and so it was a mistake to locate the tap in the interior of the engine room in the Pancoast mine where it could not be reached when most needed, on account of the fire and smoke. The logical location for the tap, if intended for available fire protection of the engine room, would have been at its intake opening near the sheave wheel. From the report I have regarding the fire, it appears that in this case, as in the Cherry and Delagua cases, the combustible material present and burned was only a factor of secondary importance, and that the most powerful and dangerous factor in spreading the fire so quickly was the strong draft passing through the engine room. The danger of this draft could have been greatly decreased by the erection of a door in the cross-heading (the air outlet) connecting the engine room with the turn out. The engineer, whenever required to leave the room for a few minutes, could then have closed this door and there would have been no excessive draft available to start a dangerous conflagration during his short absence, and, if on his return he found the engine room on fire, the tap at its entrance would have provided a ready water supply for instant and effective use.

The recent legislation in Illinois and Pennsylvania covering the fireproofing of shaft bottoms, underground stables, engine rooms, etc., is commendable, but at best it can only affect very small parts of any mine, parts, too, that by reason of location and through the advantage of having almost constant supervision, already have a greater measure of protection against fire than the less frequented interior mine workings and passages. The use of more or less timber and wood in mines cannot practically be dispensed with, and an air-current of high velocity must often traverse some parts of the mine in order to render other parts healthful and safe, and under such conditions there will still be danger that specific legislation like the above cannot be depended on to remove. Coal mines, the natural storage places of a vast fuel supply, cannot be made fireproof, but that does not mean, notwithstanding the occurrence of three disastrous mine fires in less than 2 years, that they are fire-traps, for I believe I am justified in saying that there is less danger to life from fire in the ordinary mine having fair care, than in many factory buildings and manufacturing establishments on the surface that have been examined and pronounced reasonably safe.

The most impressive and valuable feature of the combined lesson of the three mine fires is the fact brought out that forethought, preparedness, and timely action on the part of man constitute the best and most reliable safeguard against the occurrence of disastrous mine fires in the future, and the lesson also shows plainly the necessity and advantage of instruction and training of the mine worker to make him a dependable factor, and to accomplish this I suggest the enactment of a general law that, in addition to requiring the providing of certain safeguards of known merit, will direct that mandatory frequent

instruction be given the mine employes regarding the causes of mine fires, their danger, their prevention, the manner of dealing with them promptly and effectively, and the arrangement for notification and withdrawal of the mine workers in case of danger.

乘 乘

The Waterfall Chute

By Paul Sterling*

INTRODUCTION.—Among the various conveniences which have been introduced in the preparation of anthracite in recent years is the vertical step chute, known locally as the waterfall chute, or vertical telegraph. Paul Stirling, M. E., has described it so well under the heading "Chutes,"* and has interjected so much other good material on chutes, that it is reprinted from his paper on the "Preparation of Anthracite." The valuable features in connection with this kind of chute are the almost entire elimination of breakage, the saving in floor space, and decrease in complications that frequently necessitate the changing of machinery from place to place to make conditions that will aid chutes in carrying coal properly.—EDITOR.

Coal chutes are used to convey material from a higher to a lower point by gravity. If badly constructed, they cause a loss by degradation of size, which exceeds the combined losses

and of a pitch which will just allow the coal to start running after it has been stopped or held back. The corners or turns are banked or raised so that pieces will slide around without striking the sides and without drop. When the chute makes a 180-degree turn, a back switch is recommended, so that the coal may be brought practically to rest and the velocity reduced before starting down the pitch again. The following table gives the size of coal, the pitch in inches per foot of a chute for that size, and the width of the chute usually adopted. The lining of the chute is sheet steel for all sizes below broken. The lump, steamboat, and broken will slide on smooth cast-iron plates, inclined on the pitches shown.

PITCH AND WIDTH OF ANTHRACITE CHUTES

	Pitch	Width
	Inches Per Foot	Inches
Lump.....	2.25 to 2.5	36
Steamboat.....	2.25 to 2.5	36
Broken.....	2.5 to 3	30
Egg.....	2.625 to 3.25	24
Stove.....	2.75 to 3.5	24
Nut.....	3 to 4	18
Pea.....	4 to 5	12
Buckwheat.....	4.5 to 6	12
Rice.....	5.5 to 6.5	12
Barley.....	7 to 8	12
Dirt.....	8 and over	12

After steel-lined chutes have been installed in a breaker, it is sometimes found that the coal blocks at certain places by reason of lack of pitch. When it is not practical to change the pitch of the chutes, the steel lining may be replaced with bronze, or sometimes with glass, on which the coal will run at a much lower pitch. A test made in a bronze-lined chute 18 inches wide showed that, for the passage of 2 tons per minute the following pitches were required: For egg, 2.75 inches; for nut, 3.75 inches; and for barley, 4.2 inches.

The vertical telegraph consists of a wooden box-shaped pipe, shown in Figs. 1 and 2, with openings on two sides, and a series of shelves inside. The telegraph shown in Fig. 1 is used for lowering coal alone, and for that reason has shelves inclined toward the center. Each shelf is covered with a steel plate so arranged that the opening inside between shelves may be contracted or enlarged by adjustment of the plate. The openings on the side permit of observation and if so desired the breaker boss can examine the quality of coal passing through the chute, which in this case is open at both ends.

The second type of vertical telegraph shown in Fig. 2 has the same outside construction, but has shelves at right angles to each other and larger openings on two sides. This arrangement of shelves and openings permits the use of this telegraph for filling coal pockets, since as the apex of the coal in a pocket increases it blocks one lower hole in the side and causes the flow of coal to take place from the next higher hole in the chute. The coal forming on these shelves forms a slope down which the following pieces of coal roll with the smoothness of water. Tests show that when anthracite rolls down on a pile of similar coal, the velocity is uniform and the breakage practically nil; and this telegraph was designed upon that principle. The shelves are so spaced that a line tangent to the angle of repose of the coal on any shelf will be tangent to the back of the opposite shelf, so that the coal will roll down the telegraph until the filling of the pocket blocks the bottom opening, when the coal will roll down on the tangent line and discharge through a side opening.

Tests of this style of telegraph show very little loss—generally under 1 per cent. when properly constructed. They are used for all sizes up to and including egg coal. They may be of any height. The writer has designed one of large capacity (300 tons per hour) 65 feet high. The capacity for a 24-inch square telegraph is about 150 tons per hour; for a 48-inch square, about 300 tons per hour. The capacity is directly proportional to the width.

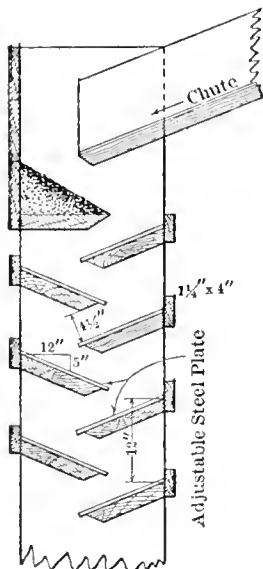

FIG. 1

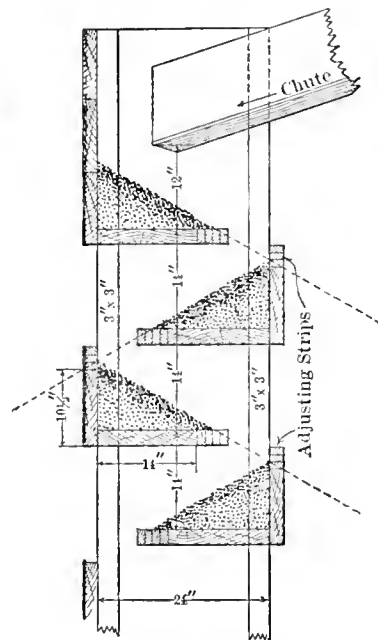

FIG. 2

from all other sources. The quality of coal varying, the pitch on which it will slide must be changed to suit local conditions. Clean coal will run on less pitch than the mud-screen mixture of coal and slate of the same size; hence, each particular chute must be built to accommodate the coal which it is to handle. The breakage of coal in gravity chutes may be attributed to the following sources: irregularities in the bottom of the chute; the striking of one piece of coal against another; drops at any point, especially at right-angle turns; and the blow which the coal receives at such turns when it runs against the side of the chute, or when one piece of coal strikes another. An ideal chute should eliminate the above features, thus reducing the breakage and increasing the mine-car yield.

Chutes may be divided into two classes, inclined chutes, and vertical telegraphs. The former are used to convey coal from a higher to a lower point not directly beneath the starting point, and the latter are used to lower coal vertically.

A proper chute is generally rectangular in cross-section,

* Mechanical Engineer Lehigh & Wilkes-Barre Coal Co., Wilkes-Barre, Pa.

British Rescue and Aid Order

Text of Proposed Order Concerning the Establishment of Rescue Stations at British Mines

A draft of an order which the Secretary of State of Great Britain is proposing to make under the Mine Accidents (Rescue and Aid) Act, 1910, is as follows: The draft order gives effect, with some drafting alterations, to the unanimous recommendations of a departmental committee (including representatives of mine owners and miners) which was appointed to frame proposals for an order under that act, and whose report was recently presented to Parliament (Cd. 5550). In accordance with the requirement of the act, the order is issued in the first instance as a draft. If within 40 days from this date a general objection is made to the order, that is, an objection made either by or on behalf of owners of mines employing not less than one-third of the total number of men employed at the mines affected by the order, or by or on behalf of not less than one-third of the total number of men so employed, the objection will, under the statute, be referred to a referee agreed upon by the Secretary of State and the objectors, or, in default of agreement, appointed by the Lord Chief Justice of England.

In pursuance of Section 2 of the act, the Secretary of State gives the following notice:

That he proposes to make an order requiring provision to be made at all mines to which the Coal Mines Regulation Act applies and in which coal is worked, in regard to the supply and maintenance of appliances for use in rescue work, and the formation and training of rescue brigades, in accordance with the enclosed draft, copies of which may be obtained on application to the Home Office; and that any objection with respect to the draft order by or on behalf of any person affected thereby must be sent to the Secretary of State within 40 days from this date. Every such objection must be in writing, and must state:

- (a) The specific grounds of objection; and
- (b) The omissions, additions, or modifications asked for.

In pursuance of Section 1 of the Mines Accidents (Rescue and Aid) Act, 1910, I hereby make the following order:

1. This order shall apply to all mines in which coal is worked; provided, however, that the Secretary of State may, if he thinks fit, exempt from the order any mine at which the total number of underground employes is less than 100 if the mine is so situated that in the opinion of the Secretary of State the organization of a central rescue station from which it could be served is impracticable.

2. No person, unless authorized by the manager or official appointed by the manager for the purpose, or, in the absence of the manager or such official, by the principal official present at the surface, shall be allowed to enter a mine after an explosion of firedamp or coal dust, or after the occurrence of a fire, for the purpose of engaging in rescue work.

3. (a) There shall be organized and maintained at every mine, as soon as is reasonably practicable, competent rescue brigades on the following scale:

Where the number of underground employes is less than 250, one brigade.

Where the number of underground employes is more than 250 and less than 500, two brigades.

Where the number of underground employes is more than 500 and less than 800, three brigades.

Where the number of underground employes is more than 800, four brigades.

But the owner, agent, or manager of a mine, at which the total number of underground employes is less than 100, shall be deemed to have complied with this provision if he has acquired the privilege of calling for a brigade from a central rescue station.

(b) A rescue brigade shall consist of not less than five persons employed at the mine, carefully selected on account

of their knowledge of underground work, coolness and powers of endurance, and certified to be medically fit, a majority of whom shall be trained in first aid and shall hold a certificate of the St. John's Ambulance Association, or of the St. Andrew's Association.

(c) There shall be selected from the ranks of each rescue brigade one person or leader who shall act as captain of the brigade.

(d) A brigade shall not be deemed competent unless (1) it undergoes a course of training approved by the Secretary of State; (2) after the preliminary course of training it undergoes in every quarter at least 1 day's practice at the mine with breathing apparatus; (3) the members of the brigade shall have received instruction in the reading of mine plans, in the use and construction of breathing apparatus, in the properties and detection of poisonous or inflammable gases, and in the various appliances used in connection with mine rescue and recovery work.

(e) Arrangements shall be made at every mine for summoning members of rescue brigades immediately when their services are required.

(4) If it can be clearly proved that the necessary number of persons employed underground at a mine will not consent to form a brigade or brigades, or having offered their services fail to be trained or maintain their training, the owner, agent, or manager of the mine shall not be liable to any penalty, provided first, that he has endeavored to the best of his ability to constitute the requisite brigade or brigades, and has afforded every opportunity to the persons employed at the mine to undergo the necessary training; and secondly, that he has made a bona fide attempt to arrange for the supply from a central rescue station of such rescue brigades as he is unable to provide at his mine.

5. (a) There shall be provided and maintained at every mine sets of portable breathing apparatus in the proportion of two sets to each brigade required by Section 3 (a). The apparatus must be capable of enabling the wearer to remain for a least 1 hour in an irrespirable atmosphere, and must be kept ready for immediate use. The apparatus must be housed in suitable receptacles in a dry and cool room.

The owner, agent, or manager of a mine shall be deemed to have complied with this requirement if he has acquired the privilege of calling for such of these appliances as he may not possess from a central rescue station, always provided that the central rescue station is situated not more than 10 miles by road from the mine and is in telephonic communication with the mine.

If it can be shown that it is not possible, at the date of this order, to procure the aforesaid breathing appliances, owing to lack of supply, the owner, agent, or manager shall be deemed to have complied with this order, if he procures such appliances as soon as is reasonably practicable.

(b) There shall be kept at every mine tracings of the workings of the mine up to a date not more than 3 months previously, showing the ventilation and all doors, stoppings, and air crossing and regulators, and distinguishing the intake air by a different color from the return air, which tracings shall be in a suitable form for use by the brigades.

(c) There shall also be provided and maintained at every mine which maintains a rescue brigade or brigades:

1. Two or more small birds or mice for testing for carbon monoxide.

2. Two electric hand lamps for each brigade, ready for immediate use and capable of giving light for at least 4 hours.

3. One oxygen reviving apparatus.

4. A safety lamp for each member of the rescue brigade for testing for firedamp.

5. An ambulance box provided by the St. John's Ambulance Association, or similar box, together with antiseptic solution and fresh drinking water.

6. There shall be kept and maintained in every central rescue station not less than 15 complete sets of breathing apparatus, with means of supplying sufficient oxygen or liquid air to enable such apparatus to be constantly used for 2 days, and of charging such apparatus; and 20 electric hand lamps; four oxygen reviving apparatus; an ambulance box or boxes, provided by the St. John's Ambulance Association, or similar boxes, together with antiseptic solution and fresh drinking water; cages of birds and mice; a motor car shall be kept in constant readiness.

7. Every central rescue station shall be placed under the immediate control of a competent person conversant with the use of the appliances.

8. There shall be adopted at every mine such rules for the conduct and guidance of persons employed in rescue work in or about the mine as may appear best calculated for the carrying out of rescue operations, and the rescue brigade or brigades, if any, maintained at the mine shall be thoroughly instructed in such rules.

9. "Central rescue station" means a station established to serve several collieries.

レ 来

Trade Notices

The Union Iron Works Co., of San Francisco, Cal., has purchased the business and good will of the Risdon Iron Works. They will continue to manufacture the line of dredging, mining, milling, and power machinery for which the Risdon Iron Works was well known and will give especial attention to the manufacture of water-tube boilers, hydraulic machinery, gold dredges, oil-well drilling tools, etc. The Union Iron Works is prepared to furnish spare parts and repairs for all Risdon machinery in service and is equipped for handling any kind of heavy machinery work.

An Electric Forge Blower.—The Sirocco electric forge blower is made in three sizes, the largest one being capable of caring for five fires. Because of the high mechanical efficiency of the new Sirocco turbine type wheel the electric current consumption for the smaller size, suitable for single light fire, is less than half the current consumed by an ordinary electric lamp. The larger sizes are relatively of equal efficiency. There are no belts or pulleys, and the Sirocco patented wheel being set-screwed to the motor shaft, there are only two bearings on the entire machine. They have high mechanical efficiency, hence small current consumption, are quiet running, and give a large volume of air at ample pressure to overcome resistance of tuyere and fire, and are smooth in operation, due to extremely small diameter of runner. They are manufactured by the American Blower Co., of Detroit, Mich.

Coal Washing Plants.—The Roberts & Schaefer Co., engineers and contractors, of Chicago, have closed a contract with the Nicola Valley Coal and Coke Co., of Vancouver, B. C., for the designing and building, complete in operation, of a 500-ton Stewart coal-washing plant for installation at their mine at Merritt, B. C., at an approximate contract price of \$40,000. They will also install a large coal-washing plant at Rathburn, Tenn., for the newly reorganized Durham Coal and Iron Co. The approximate contract price will be \$75,000.

The Oklahoma State School of Mines Laboratory.—The contract for the equipment for the new Oklahoma State School of Mines, to be located at Wilberton, has been awarded to the Allis-Chalmers Co. The plant covers a complete equipment for an ore-dressing laboratory consisting of Blake, Dodge, and Gates type of crushers, a Bridgman automatic sampler and sample grinder, a tube mill, steam drying pans and ore-bin fixtures, three elevators and a set of three screens with feeders, a feeder and two sets of rolls; a concentration section consisting of five-compartment, three-compartment, and two-compartment jig, two-spigot Richards hindered settling classifier, a Callow

pulp-thickening tank, two small size concentrating tables and a Frue vanner, together with necessary pumps; a gravity stamp section consisting of feeder and gate, five 500-pound stamps, copper table, amalgam trap, and pumps; 3½-foot Huntington mill with feeder and gate, copper table and amalgam trap; 30-inch amalgamating pan, dewatering cone, clean-up pans, pumps, etc.; a chlorination plant consisting of precipitating, storage, and settling tanks, lead-lined chlorination barrel and fixtures; a cyanide plant consisting of solution tanks, leaching tanks (one with mechanical agitator), gold tanks, sump tanks, filter boxes, pump and fixtures; a magnetic separating plant consisting of Dings magnetic separator and detail equipment. The total cost of this plant erected will be approximately \$25,000 and will represent one of the most complete laboratory equipments in that section of the country.

Safety Lamps and Apparatus.—To operate successfully a large mine entirely by locked safety lamps requires system, care, and a considerable labor. In England, many mines are so operated, and such attention has been given there to the equipment of them with dependable safety lamps and machinery for cleaning, filling, locking, and relighting with special relighters or in safety stations underground. A catalog recently issued by Ackroyd & Best, Ltd., Morley, near Leeds, England, describes different styles of safety lamps, with magnetic and other unlocking apparatus, Hailwood's underground relighters, lamp racks, and oil tanks, as well as lamp cabins equipped complete with lamps and labor-saving machinery suited to the care of the lamp equipments of the largest mines. Messrs. Ackroyd & Best have an American office at No. 2 Arrott Power Building, Barker Place, Pittsburg, Pa.

The Metallic Flexible Tubing Co. announce that all their patent rights, stock, machinery and fixtures are transferred to Mulconroy Co., Inc., 722 Arch Street, Philadelphia, manufacturers of flexible metallic hose and tubing. The name and registered brands will be continued. The Mulconroy Company has improved and additional machinery to manufacture all kinds of flexible metallic hose and hose coverings, and a centrally located factory.

Christy Box-Car Loaders.—A number of mining companies have recently installed Christy box-car loaders at their mines. Among these are the Lilly Coal Co., of Altoona, Pa., for their Lilly mine. The Consolidated Fuel Co. have purchased two improved loaders for their Hiawatha, Utah, mine. These two will load two grades of coal simultaneously on different tracks. The St. Louis and O'Fallon Coal Co., of East St. Louis, have installed a semiportable loader at their No. 2 mine. An order has also been received for a large portable dock loader to be used on the new dock at Manitowoc, Wis. This dock is operated by the C. Reiss Coal Co., of Sheboygan, and this is the second Christy loader used by that company.

Steam and Air Specialties.—A catalog describing gauges, cocks, water gauges, pressure regulating valves, and other steam specialties has been issued by the Ohio Brass Co., Mansfield, Ohio. It is sent free on request.

Copper Wire, for trolley lines and the transmission of electrical currents, manufactured by the Hazard Mfg. Co., of Wilkes-Barre, Pa., has won a high reputation on account of trueness to gauge and its high conductivity. Unless otherwise specified it is thoroughly annealed. When insulated wires and cables are desired for any purpose, and especially for mine use, the insulation is such as to maintain the high standard of excellence which has won for Hazard products an enviable reputation.

Removal.—The C. S. Card Iron Works Co., of Denver, have moved to their new shops on Alcott Street, where they now have a most complete and modern works devoted exclusively to the manufacture of coal-mine equipment. The shops include foundry, forge, sheet iron, machine, and car shops, all provided with cranes and industrial railways for the economical handling of material. These improvements enable them to take care of all requirements promptly and in a careful manner.

Coal Dust and Zone Systems

A Criticism of the Report of the Commission on British Coal Dust Experiments

By E. O. Simock

In the Transactions of the Institution of Mining Engineers, E. O. Simock publishes a paper on the "Prevention of Coal Dust by the Zone Systems," of which the following is an abstract:

Among the means of staying the inflammable propagation set up during a coal-dust explosion, zone systems are now taking a prominent place; and these remarks question whether there are sufficient facts available to enable a sound opinion to be expressed as to their practical utility.

The precise conditions and requirements for inflammable propagation are not exactly known, but an hypothesis may be deduced from the observations of many careful investigators who, during recent years, have given much attention to the subject.

Most of the theories advanced assume an instantaneous action throughout the mine, but this is untenable, for there is absolutely no evidence that natural coal dust *per se* is explosive. It must be mixed with an oxygen derivative, and in this case, the oxygen derived from the atmosphere. That the dust must be mixed intimately with the atmosphere after the explosion has commenced is shown by the fact that during normal working conditions there is insufficient dust floating in the air to support this inflammable propagation, and the theory of the pioneering action of the air stirring up the dust, gives a good general explanation as to the second essential to the continuous action.

The first essentials are the reactionary materials, in this case there must be a large amount of intimately mixed fine coal dust in suspension in the air. This intimate mixing of air and coal dust must be part of the general phenomenon pertaining to this propagation of combustion. Under these circumstances, it may be taken as an axiom that, after the initiation, the flame or heat does not advance first, but follows the stirring up action. But there would be no pioneer air movement without a difference of pressure being set up and maintained by the heat generated during the reaction. These two actions are mutually dependent and the cessation of one will stop the other.

The question is, will zones, wet or dry, dustless or treated with inert dust, stop the pioneering air wave; or, alternatively; will they stop the reaction of combustion?

Mr. Hodges champions the dry, dustless zone; Mr. Henshaw argues the case for the wet zone, and strongly supports the opinion as to the action of inert dust. Both have made extensive observations of the after results of explosions, and base their arguments upon what they have respectively observed.

In the instance given by Mr. Hodges† of a dustless zone stopping the propagation of the Blackwell explosion on October 11, 1895, the evidence upon which this assumption is based requires careful reconsideration, for the conclusion does not seem to be warranted. The fact of there being no dust in this length of roadway may have conduced to the prevention of propagation in that particular direction; but if other factors had not been present, it is doubtful whether this alone would have prevented the explosion from extending beyond the downcast shaft.

The incident under review occurred in a road in Blackwell colliery of which Fig. 1 is an approximate plan. The arched road is not in line with the road whence the explosion traveled, and the deviation commenced at a place that formed the junction of four roads. Owing to this bend in the road, the force would largely expend itself in attempting to maintain a straight line. There would be a rebound, and this rebounding wave would materially conduce to the stoppage of the explosion

in that direction. Coupling this with the fact that there were two other roads open for the explosive force or wave to take, the assumed value of the dustless arch is considerably weakened.

What effect a rebounding action has in stopping an explosion is well shown by what occurred in the breakthrough connecting the intake with the main return. In this breakthrough three doors were blown down, but the propagating wave traveled no farther in that direction. This was attributed to the non-inflammable nature of the dust; but it has been shown that dust containing 80 per cent. of inert material will support propagation, so that this conclusion cannot, without further evidence, be sustained.* The force required to break down these doors would have to be transmitted through the air. This compressed air would receive a check when it came in contact with the doors, and this would cause a backward moving wave which would be strong enough to stop or "blow out" the inflammable wave.

Corroboration of this action is found in the Denny explosion,† where the propagating wave was stopped by the rebound set up at a door. Further confirmation is shown in the case of the Talk-o'-th'-Hill colliery explosion of May 27, 1901. At a point *a*, Fig. 2, close to where a sample of dust was taken, there was a pair of doors, and at or about this point the propagation ceased. In this case the rebounding action may have been enhanced by the fact that the workings, which are pillar-and-stall, did not extend very far beyond this point, which would materially help quick compression.

That this rebounding action is a great deterrent of propagation can be gathered from the fact that the lives of men working

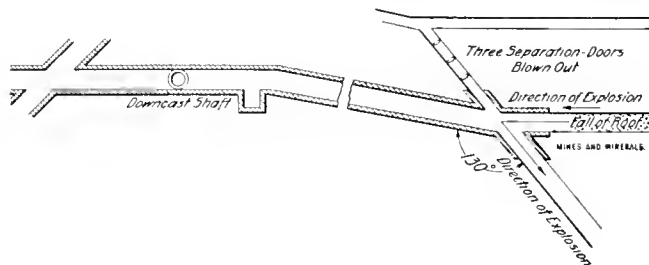

FIG. 1. PART OF WORKINGS AT BLACKWELL COLLIERY

at the face in blind headings have been saved, although the explosive wave had entered the heading; but had been unable to reach the face; owing to the backward action of the compressed air.‡

Applying this fact to the various actions which occurred in the case of the Blackwell explosion at the junction of roads, as illustrated in Fig. 1, it will be seen that what happened can be reasonably explained without reference to the dustless condition of the arched length of road. A rebounding action would be set up both at the commencement of the bend in the arched road and at the doors in the breakthrough at the moment of impact, and this rebound, plus the remaining energy in the explosive wave, would find a vent by passing into the southwest road. The southwest road is about the natural line that a force would take as the result of the three mentioned; so that to this dustless arch is given credit which does not belong to it.

A. M. Henshaw's opinion§ is that 100 yards of wet roadway will stop an explosion, and in his opinion, explosions have been stopped by wet roadways of less length. On the other hand, W. W. Hood, in his evidence,|| states that at Clydach Vale colliery the explosion on March 10, 1905, traveled along 700 yards of well-watered, closely timbered roadway, and that

* See discussion later.
 † Report of the Royal Commission on Mines, 1908 [Cd. 3,873], Vol. II, page 228.

‡ Editor's Note.—See "Primero Explosion," MINES AND MINERALS, March, 1910; "Delagua Explosion," *Ibid.*, 1911.

§ Report of the Royal Commission on Mines, 1908 [Cd. 3,873], Vol. II, page 14.

|| *Ibid.*, page 100.

† Report of the Royal Commission on Mines, 1908 [Cd. 3,873], Vol. II, page 62.

10 days after the explosion the timber in this road was still found to be wet. It has been contended that along this length of roadway the explosion was fed by gas and dust, blown from over the timber. Such an argument lacks corroboration, for there seems to be no record of gas having been found above this timber, either before or after the explosion. Then, as regards dust, if there were any present, the fact that it was not in the path of the current would tend to preserve it from disturbances by the pioneer air wave, and if disturbed by the disruptive effect of the main reaction, it would then only serve as a palliative. W. Armstrong, the manager of Wingate Grange colliery at the time of the explosion on October 14, 1906, records in his evidence* that the explosion, which was one of dust initiated by explosives, traveled over 200 yards on a damp and dustless roadway.

If a wet, well-timbered length of road of these proportions will not stop an explosion, it is doubtful whether an arched zone—wet or dry—will be more effective, for, in this case, there would be less resistance to the dust-laden air, as the smooth cemented sides and roof will help the dust traveling in the

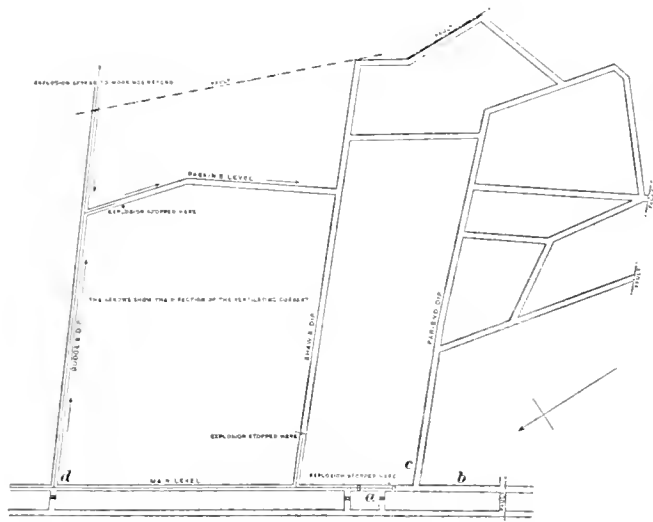

FIG. 2. PART OF WORKINGS OF TALK-O'-TH'-HILL COLLIERY

pioneering air-current to pass quickly along the zone, thereby setting up conditions favorable to the propagation of combustion in the zone itself.

The system of zones, advocated by A. M. Henshaw in his evidence before the Royal Commission, is the best system promulgated, but, having regard to the possible long intervals between the zones, it is doubtful whether such a system would have a great deterrent effect. The distance between the zones is about 400 yards; and, presuming this length to be dry and dusty, it is probable that the pioneering action will be so developed that its velocity will be sufficient to force a mixture of air and dry dust into and through these zones.

In the Blackwell case the explosion traveled about 400 yards before reaching an arched dust-free zone, where two other roadways met. Consequently, owing to the largely increased sectional area which the initial pressure had to cover, the pressure per unit of area would drop, and as a result, notwithstanding this drop there was sufficient power and heat left to take the propagating action round the very sharp bend into the southwest road beyond the arching therein, and to start the dust-and-air reaction there. If there had been no great variation in the area, and only the one road for the explosion to take, there is no reason to suppose that the pioneering action was not carrying forward sufficient dust to allow the explosion to travel to the shaft or beyond.

The disaster at the Marianna Mine of the Pittsburg-Buffalo

* Report of Royal Commission on Mines, 1908 [Cd. 3,873]. Vol. II, p. 100.

Coal Co., Washington County, Pa., on November 28, 1908, showed what occurs during an explosion when the roads are of equal section and there are no other differentiating circumstances. This colliery was only being developed, and all the roads were in the fast coal, so that a large accumulation of dust is improbable. An efficient water supply was laid throughout the mine, and all conceivable precautions were taken. The mine inspector had completed a careful inspection of the mine but half an hour prior to the explosion, and was satisfied with all that he saw. Yet, notwithstanding the wet roads and no noticeable evidence of a dangerous accumulation of dust, the mine was devastated. Had there been a stoppage of the explosion following on a drop in pressure, owing to a sudden enlargement of the sectional area, it is presumed that the water treatment to which these roads had been subjected, would have received the credit; but, as a matter of fact, the roadway from face to shaft was practically one wet zone, which failed to stop the inflammable propagation. Therefore, in the writer's opinion, further evidence of the practical value of wet zones is required before such methods are adopted.*

There remains the hypothesis as to the stone-dust or inert-material zones, which are now being advocated as a result of the coal dust experiments at various stations. Zones of this description were suggested by Conrad Gautsch, of Munich, in 1896. He later took out letters patent in this and several other countries for such zones, proposing to use boracic acid as a deadening substance, but he did not confine himself to the use of any one substance. The present exponents of this hypothesis base its claim upon observations after explosions, where such explosions have apparently been stopped, owing to the augmented dirt or ash contents of the coal dust. Although the experiments at some of these experimental stations seem to show† conclusively the hypothesis to be an actual fact, yet, when the evidence is carefully examined, it will be seen that there is little upon which a claim for practical utility can be based. The advocates of the theory have a fair number of disciples. Several have expressed the opinion that inert material, in lieu of water, would be efficacious, and such opinions have been expressed and recorded by others many years ago, but simple assertions without evidence in support on such a question are not convincing arguments.

It is almost a universal opinion that the distillation and combustion of the volatile matter of the coal dust is the cause of propagation. The merits or demerits of this opinion the writer does not wish to enter upon, but it is mentioned here to show that the inert-dust theory and this theory are at variance.

Assuming that the volatile matter is the cause of propagation, then, if the dust with the least percentage of volatile matter that has allowed propagation to proceed is taken as a standard of comparison, it will be seen that there must be a reconsideration of one theory or the other. Taking the dust of the Albion colliery, which was the cause of one of the most disastrous mine explosions in this country, and comparing the percentage of volatiles with any of the percentages of volatiles given in the two sets of analyses, it will be found that, with two exceptions, their volatiles are much higher. The volatiles in the dust of the Albion colliery were only 14.1 per cent., yet in the case of the Courrieres explosion a dust containing 22.25 per cent. of volatiles is said to have arrested the explosion; and in the case of the Talk-o'-th'-Hill explosion, the dust at *b*, Fig. 2, containing 21.37 per cent. of volatiles is said to have stopped it. There seems to be something anomalous here, and either one or the other theory is wrong, or possibly both. The two exceptions mentioned are in the list of the Talk-o'-th'-Hill dust analyses, and are as follows:

*EDITOR'S NOTE.—See United States Bulletin 425, also Record of First Series British Coal Dust Experiments.

† See "Shale Dust and Coal Dust Tests at Broxburn," by Robert McLaren and William Clark, Tran. Inst. M. E., 1909, Vol. XXXVIII, page 362.

No. 3. Coked dust, 8 feet level, from the flanges of a girder in the roof, outby side: Carbon, 36.05; volatiles, 9; ash, 54.95.

No. 4. Coked dust from the same girder, inby side: Carbon, 24.90; volatiles, 13.95; ash, 61.15.

The coked condition of the dust is taken as evidence that the inflammable wave passed that way, and had this condition not been in evidence, presumably it would have been assumed that the action had ceased there, owing to the dirt contents of the dust. Prof. W. Galloway, however, mentions a case, in his lectures on mining,* in which the inflammable wave passed along a road without leaving any evidence of its passage in the shape of coked dust, and he attributes this want of coherence to the shale dust and other impurities present. The writer believes that somewhat similar observations were made at West Stanley colliery. In some experiments with dust which would coke in mass, the writer observed that if it were traveling at a fair velocity, it did not cohere, although it was subject to temperatures ranging from 390° to 1,650° F. (200° to 900° C.). This dust was not impure, but it was rather dry, and it may be that the difference of moisture contents and the fact of its not being quiescent will account for the difference in coking ability. Impurities, of course, unless fluxible, will largely prevent coking or coherence. The presence and condition of the dust on the girder is negative evidence, both of high velocity and of high temperature, and direct evidence that it contained moisture.

A covering note to the table of analyses of the Talk-o'-th'-Hill dust says:

"The figures show that roads which contained dust with ash up to 31.75 per cent. were traversed by flame. The explosion was stopped where the dust contained 44.73 per cent. of ash, as at *b* Fig. 2, and possibly by 39 per cent. of ash, as at *c*."†

The two last-named dusts, however, contained respectively 21.37 and 24.15 per cent. of volatiles, as compared with 14.1 per cent. of volatiles contained in the dust of the Albion colliery, which allowed propagation to proceed. It is also interesting to compare the ash contents of samples taken at *b* and *c* with those of Nos. 3 and 4. It is impossible to reconcile the apparent fact that in one case 39 per cent. of ash stopped combustion, and in another, combustion proceeded with over 60 per cent. of ash.

By a reference to Fig. 2 it will be seen that the explosion stopped some distance outby from the place where sample *b* was taken—at a point where there was a pair of doors. Beyond this point inby, the workings were of small extent, and practically a cul-de-sac. These facts, combined with that of the resistance set up at the doors, would be sufficient to explain why the explosion ceased at that point, although the dust contained sufficient volatiles to allow propagation. They do not, however, explain why the explosion did not travel far up Shaw's Dip, which was on the outby side of the doors. It will be seen that Shaw's Dip represents one side of a rhomboid, the four sides of which are the main level, Bodge's Dip, Paskin's Level, and Shaw's Dip. The explosion stopped a short distance along Paskin's Level. The explosion entered at the junction *d* and the propagating action continued along the main level and started up Shaw's Dip, in addition to continuing along the main level to the doors near *a* which stopped in that direction. The wave going up Bodge's Dip divided at the junction with Paskin's Level, the one part continuing up the dip and spreading to workings beyond, and the other entering the level and stopping at about the same distance in the level as in Shaw's Dip. These two points are about equidistant from where the pioneering action entered the rhomboid, and the two wave forces, which would be of about equal magnitude, were opposed to each other. Therefore, the axiom, that when two forces of equal magnitude are opposed they will neutralize each other,

is well illustrated, for the explosion ceased in both directions. Of the four routes taken by the explosion in this part of the mine, in three it met with opposition sufficient to stop the action; but in the fourth route, meeting with no check, it spread to the workings beyond. There is nothing therefore in the observations in connection with the Talk-o'-th'-Hill explosion which will substantiate the inert-dust hypothesis.

W. E. Garforth based the inert-dust theory upon observations after the Altofts colliery explosion, which occurred in 1886. He does not record any dust analyses, but assumes that, as the explosion did not in any case reach the coal face, it must of necessity have ceased through the non-inflammable nature of dust. A glance at any of the published plans of the workings of the Altofts colliery affected by the explosion will show that the coal face is practically the circumference of a circle, connected to the shafts inside that circle by radial roads. The explosion passed up these roads toward the face or circumference, and, as there was no outlet, each line of force tended to meet and oppose the others. Thus, each force traveled onward inby until met by an equal, or stronger, opposing force, and so was stopped.

Here, then, are similar explanations—without reference to lengths of roadway containing inert dust—of the stoppage of the two types of explosions upon which the modern theory of the inert-dust remedy is based, and any argument showing that these explanations are incidental and the similarity coincidental will be awaited with interest.

It has been remarked that the theory of the propagation of combustion due to distillation of the volatiles contained in the coal dust, or the theory of inert material, or both, are anomalous. It has also been observed, from a comparison of coal dust responsible for an explosion with dust collected after an explosion, that the first contained less volatiles than remained in the second.

This evidence seems to point to the carbon constituent of the coal as being the principal cause of the propagation of combustion. Assuming the truth of this, if it could be shown that a mixture of inert material, carbonaceous matter, and free oxygen or air would not burn, or allow the propagation of combustion to proceed, then it might be said that zone systems, based upon this inert-material theory, have a substantially practical basis. There are, however, many every-day examples which are evidence to the contrary, and one of these may serve to demonstrate the futility of the application of inert material.

In the North Staffordshire and other mining districts, there are heaps of burning pit debris. It is doubtful whether any of these contain more than 10 per cent. of inflammable material—in the writer's opinion, 5 per cent. would be more accurate—yet combustion proceeds. The difference between the inflammable material in the heap and that found on the roadways of a mine is one of degree of fineness only. Therefore if such material be reduced to the requisite fineness, and floated in the air in sufficient quantities, it is doubtful whether it can be proved that this would not burn with sufficient rapidity in a semi-enclosed place, such as a mine roadway, to produce explosive violence.

The recorded experiments of Captain Desborough,* showing that dusts containing 80 per cent. of inert material are capable of supporting the propagation of combustion, even in a tube of small diameter, must be taken into consideration; and this fact, taken in conjunction with the practical impossibility of totally eliminating coal dust from any given length of haulage road, makes it evident that any zone system so far suggested is unreliable.

The discussion on this important paper which brings out some interesting points will be printed in an early issue of MINES AND MINERALS.

* 1909, Subject 7, "Colliery Explosions, Firedamp, and Coal Dust," page 24.

† Report of the Royal Commission on Mines, 1908 [Cd. 3,573], Appendix I, page 295.

* Second Report of the Royal Commission on Mines, 1909 [Cd. 4,820], Appendix III, page 247.

Oils for Lubrication

The Action of An Oil in Preventing Friction. Qualities Necessary and Methods of Testing

By C. E. Ward*

All are aware that the metal bearing can absorb a great amount of frictional heat but cannot free itself of it as fast as generated; therefore, a lubricant with a fire test far above the normal temperature of the bearing is applied so it can absorb and carry away the frictional heat, and thus keep the bearing in normal conditions.

If the oil or lubricant be of low fire-test the result is a hot journal. A high fire-test oil does not mean a cylinder oil of 600° F. to 650° F., as this class of lubricant on a rapidly moving journal would cause as much trouble as a low fire-test lubricant, for, it being heavy and viscous, it could not readily flow over the rapidly moving parts, and if a square inch of the surface, or even a very much smaller area were not covered, friction would immediately increase the temperature of the bearing, and if not carefully attended to would result in a hot bearing.

Have any of you given it a thought while you were riding in a railroad train that you were riding on oil? As a simple illustration of how friction and how lubrication act, rub the hands while in a dry state rapidly together, and feel the heat generated; next soap them or drop some oil on them and one hand will glide over the other and become cool almost immediately, thus overcoming the friction. If water should be applied the hands would become cool, but would not move on each other readily. Should any pressure be applied they grit on each other, showing conclusively that while water is an excellent cooler it is not a lubricant.



FIG. 1. BAUMÉ HYDROMETER

As everything depends upon the successful turning of the wheels around a mine, mill, railroad, steamboat, and in fact every mechanical device, it is necessary to overcome friction with the proper lubricant or operation would be at a standstill.

The greatest expense around coal mines is the lubrication of the mine cars, still this lubrication is often left to boys, who think all they have to do is squirt the oil at the wheel on the sides of cars and use it up as fast as possible or the boss won't think they are doing their work. Evidence of this is seen along the track where oiling is done; four or five times more oil is used than is necessary to run the cars successfully if the oil is properly applied.

The wheels used are also factors in poor lubrication. The method of carrying the oil in a receptacle between the spokes is objectionable in my opinion, for when a wheel revolves at the rate of 2 miles per hour with a thin limpid oil the centrifugal motion throws the oil away from the axle, and while the wheel is in motion it gets no lubricant. If some one would get up a practical wheel that could be lubricated with grease in the winter months as well as summer, and a device that would feed the grease gradually to a journal without generating any heat to liquify it, it would solve the question of the greatest expense of lubrication around the coal mines. The cost of pit-car oil to one company is as high as 1½ mills per ton, while all other lubricants average ¼ of a mill per ton of coal mined.

Very often oil is condemned unjustly, not that the oil company is infallible, but in many cases good oil is condemned. For example, take wheels with 2-inch axles under a car which weighs loaded 4,000 pounds. Each axle sustains a weight of 1,000 pounds on an area on its under side of ½ in. × 6 in. long, or, carrying on ¼ of a square inch 1,000 pounds. The best

authorities state that oil will not pass between two surfaces under pressure of more than 800 pounds per square inch, unless forced there. Many operators have increased the capacity of the car bodies, never giving the axle or the weight of the wheel any thought; as a sequence, the axles are flattened on the under side owing to the excessive weight and the two metals coming in contact tear particles from each other, thus reaming out the wheel and further injuring the axle. Then a new wheel is put on the flat axle and in a very short time this wheel is reamed out and the oil is blamed. Bent axles are placed frequently under heavy loads, and a bent axle will ream out a wheel in a very short time, and the oil is the cause again to the uninitiated. In many cases where the oil is unsatisfactory, it will be found due to some mechanical defect when one sifts the complaint down. There are cases where the oil is at fault, but in every instance thus far that has come under my observation, where the oil was at fault a mistake was either made in the shipment or it was improperly used. In several instances where they were having trouble lubricating the cylinders of a hoisting engine, investigation showed that pit-car oil was being used, and this, being low in fire test and having no admixture of animal or vegetable oils, did not emulsify and coat the walls as would a properly compounded oil.

To ascertain whether an oil is suitable for the purpose it is to be put to it is subjected to tests.

Viscosity is the degree of fluidity of an oil or the ability to adhere to: viscos; sticky. By comparing the viscosity of one oil with another which has been giving good results in practice, a test is made with a viscosimeter, a number of which are on the market; but as one cannot always have these instruments in the engine room, a simple method to test the viscosity of one oil with another; i. e. (this will only apply to engine oils), is to take a medium piece of glass, place on an incline, then place a drop of each kind of oil side by side on the glass at top. The oil that reaches the bottom first is the less viscous.

Viscosity is the first thing to be considered, as the most fluid oil that will do the work and stay in place is the best engine oil. The viscosity is generally taken at 70° F. to 100° F., which compares with the temperature of the average bearing, while the cylinder oils are tested at 212° F., or boiling point of water.

The writer, in testing cylinder oils, heats the oil to 338° F., which is the temperature of the steam at 100 pounds pressure. In making a number of tests it was found that cylinder oils from a petroleum with an asphalt base will stand up in viscosity with the best of Pennsylvania cylinder oil at 212° F., but go all to pieces at 338° F., hence the reason of testing at 338° F., or the temperature at which it is used.

The standard of specific gravity is water and the specific gravity of oil is the weight of the oil compared with water. It is readily obtained by the use of the Baumé hydrometer, Fig. 1. The temperature is taken at the time, in case it is not 60° F., and for every 10° F. subtract 1° B. from the hydrometer, if it be above, and add 1° B. for every 10° F., below 60° F.

The formula for ascertaining the specific gravity is $\frac{140}{130 + B^\circ}$.

The hydrometer is first placed in water and sinks say to 10; it is next placed in the oil to be tested and sinks to 30; then by use of the formula $\frac{140}{130 + 20} = .933$, as the specific gravity.

The flash test of an oil is the temperature to which the oil is heated to give off vapors, which, when mixed with air, produce an explosive mixture. The flash point of an oil is considered important, as an oil with low flash point, in mills, especially the cotton mills, that would give off gaseous vapors at low temperatures would be dangerous.

The fire test of an oil is obtained by continuing to run the temperature of the oil up after the flash test, until the vapors that are given off will ignite and burn continuously. The size of the cup, the quantity of oil, and the size of the test flame are noted in this test.

* Oil Inspector, Pittsburg Coal Co. Paper read before Coal Mining Institute of America.

The cold test of an oil is the temperature at which the oil will just flow.

Compounded oils are used to a great extent, in fact it is difficult to get an oil that is not compounded. It is the writer's opinion if an oil is properly compounded with petroleum products of proper physical test, good results will be obtained; but, if it be compounded with semidrying oils, such as corn oil, rape seed, castor oil, or any of the blown oils (the latter is sometimes used to increase the viscosity of lubricating oil), the results will not be as satisfactory.

It is also the opinion of a number that a mistake is made in using a light-colored oil; for to obtain this oil it is treated with sulphuric acid, and the acid is neutralized with caustic soda. In a number of cases when a well-known oil, treated as described, came in contact with the water from cylinders, it became milky and emulsified and made the oiling system inoperative by clogging. One point should always be kept in mind, that is, one does not lubricate with color.

It has been found that the best universal results are obtained by using a non-treated engine oil having the proper physical test that has been filtered once through bone charcoal to eliminate any burnt carbon or suspended matter. It has never turned milky or emulsified, although this class of oil has been in service for 6 years undergoing all kinds of conditions. The compounder is the same in relation to mechanical movements as the doctor is to his patient in prescribing for the different ailments and troubles to be overcome. Compounding is a science.

In a paper of this kind one cannot lay down with any degree of accuracy the grade of oil one should use or how it should be used any more than one could tell you how you should raise your children. Personally, I believe the only practical method of reducing the cost of oil and keeping it down to the minimum is to have one conversant with oils and lubrication in general to pass all requisitions, to visit mines, and keep in touch and familiarize himself with all the machinery and their requirements.

來 來

Coal Mining Notes

Berwind-White vs. Farmers—Trespass.—A rather serious or what might, because of prejudice, have become a serious case, was brought by a number of farmers against the Berwind-White Coal Mining Co. for trespass, and over \$2,000,000 damages were demanded.

The problem involved the identity of the coal bed being mined by the defendant company. The integrity of nomenclature of the Lower Productive Coal Measures was attacked, it being claimed that bed *C* and not the *B*, or Lower Kittanning, was being mined upon the land of the plaintiff. The case was not merely of a local nature but was most decidedly general, as an attempt was made to discredit the nomenclature of the entire first bituminous basin of Pennsylvania. The case involved a search of the records for 70 odd years, an examination of sections and the bed itself over an area of upwards of 100 miles. By the aid of geologists it was possible to establish the identity of the bed beyond question and the farmers' attorney requested Judge Kooser to instruct the jury to render a verdict for the Berwind-White Co.

Death Due to Detonating Caps.—In an explosion of detonating caps and dynamite at North Mahanoy mine of the Philadelphia and Reading Coal and Iron Co., one man was killed outright and three injured, one having his eyes blown out and his hands blown off. The men were carrying explosives into the mine. Had the advice on handling powder and caps so frequently given in MINES AND MINERALS been observed this accident would not have occurred.

Powder Strike.—Because they were prohibited from using black powder by State Mine Inspector Williams, of Johnstown, the 230 employees of the No. 2 plant of the Argyle Coal Co., at

South Fork, Pa., quit work. The inspector, on a visit, discovered an unusual quantity of gas in the mine, and as a precautionary measure, ordered the black powder cut out. The men objected, alleging, the permissible explosive recommended by the inspector was not as effective as black powder and their earnings would be proportionately reduced. They were out three days, when permission was given them to resume the use of the powder. Some years ago a somewhat similar strike occurred in Nova Scotia that was not so readily settled.

Enforcement of Mine Laws.—The superintendent of the Price Hill Colliery Co.'s mine on New River has been found guilty of permitting men to enter the mine before an examination had been made of the mine for dangerous gases. No accident followed, but the superintendent, who stands high among the officials of the New River Co. and subsidiaries, was assessed a fine of \$50, the commission issued him by the state department was revoked and his removal as superintendent demanded. In the circular letter being sent out, the district inspectors are ordered to prefer charges against mine officials for every violation of the law. "If mine officials persist in violating the law we will have some of them in the penitentiary," said Chief Laing in an interview at Charleston recently.

Pittsburg-Buffalo Inspection Committee.—An investigating committee composed of A. C. Besson, chief engineer; W. J. Holsing, general superintendent; and Sim Reynolds, so well known to the readers of MINES AND MINERALS, has been appointed by the Pittsburg-Buffalo Co. to visit the different mines of the company at stated intervals and make a thorough inspection with the view of improvements along the line of safety and economy. Report of this inspection is to be made in detail to the general manager of the company and instructions issued to the management of each mine in accordance with the recommendations of the investigating committee.

University of Illinois School of Mines.—The University of Illinois will receive for its support for two years, following July 1, the sum of \$3,500,000. One-half million dollars is for buildings. The College of Engineering obtains \$192,000 for maintenance and for a building \$200,000. The Department of Mining Engineering, in addition to this, has an appropriation of \$35,000 for maintenance and \$25,000 for equipment. The legislature in providing for the future support of the University has authorized a 1-mill tax upon the assessed value of the state. This it is expected will furnish over \$2,000,000 per annum to the university.

來 來

Lake Superior Mining Institute

A. J. Yungbluth, secretary of the Lake Superior Mining Institute, states that the local committee on the Menominee Range have selected Tuesday, Wednesday, and Thursday, August 22, 23, and 24, as the dates for holding the sixteenth annual meeting, and the council has voted in favor of the same. Arrangements are now under way for the entertainment of the members and further circulars will be issued containing the itinerary of the trip together with list of papers to be read, also any excursion features which may be decided upon.

來 來

Kentucky College of Mines and Metallurgy

The board of trustees of the State University of Kentucky has changed the name of the School of Mining Engineering to that of the College of Mines and Metallurgy, which composes the School of Mining Engineering, the School of Metallurgy, and the School of Extension. The School of Mining Engineering will offer three courses as follows: A four-year course leading to the degree of mining engineer, a two-year course leading to a certificate of proficiency in the work covered, and a 10-week course for practical miners. The School of Metallurgy will offer a four-year course leading to the degree of Metallurgical Engineer. The School of Extension will take instruction to the miners in the field, lectures being given at various points in the state.

Coal Mining Institute of America

*Presidential Address of S. A. Taylor**

"How Can the Bituminous Coal Industry be Placed on a More Stable Basis?" was the subject which President S. A. Taylor, of the Coal Mining Institute of America, took for his address at a recent meeting of the Institute at Indiana, Pa., of which the following is an abstract:

He assumed that the bituminous coal industry was in an unsatisfactory state and that there was something radically wrong with the business. If there was any doubt about this, he said all that was necessary was to consult the operators on one hand and the miners on the other. In discussing the elements that entered into the cost of coal to the consumer he stated that in the home market where there was plenty of coal, in some sections of the East there was also plenty of wood, gas, and oil, which competed with coal. All that the operator desired was that the price of coal should be fair to the consumer, fair to the operator, and fair to the mine labor, but this could not be accomplished easily under existing conditions, as the location of coal and the cost of transportation vary according to the locality of the consumer and whether there is competition at his place.

Continuing, he said: There are a number of things which enter into the cost of production of coal and these either add or subtract from its price to the consumer. A strike in some district of the country may induce people to enter the coal business in the district from which coal must come to supply that suspended temporarily by the strike. In a number of places coal mines can be opened and worked cheaply by people with small means, and after they are once started it seems compulsory for them to continue so long as they can keep business going. This results often in unfair treatment to their men and customers. With such conditions there can be little or no control of the output of the mines.

There is another factor which recently has become quite an item of cost to the consumer, that is, the requirements of some of the specifications that coal should be purchased only on the basis of heat units and compelling forfeits to be paid by the producer if the coal he ships falls below the heat units guaranteed. The United States Government is one of the large consumers that purchase coal on this basis, and is therefore placing a premium on the waste of coal in the mines from which they purchase, for the reason that only the highest grade of coal can meet the requirements of the specifications, and for this loss and extra cost of production the operator must be paid if he in turn can pay the miners and others employed in connection with the production of coal. This is levying a toll upon the future population of our country which cannot be abolished until the national government shall act in a fair and intelligent manner in the matter. This may seem at first thought an unwarranted interference on the part of the government, but as I will attempt to show, I believe that not only would it be well for the coal industry to have the government so interfere but it is a duty the government owes to the industry as well as posterity to so interfere.

The coal operator holds a position as middleman between the consumer on one hand and the mine laborer on the other. The consumer demands low prices, while the mine laborer demands high wages. In addition to being ground between two millstones, the operator is usually the recipient of unjust newspaper criticisms. The press has much to do with the opinion in which the public holds the coal operator. He is called "coal baron" and other terms that deride and tend to belittle him before the public. Without any knowledge of facts and without any truthfulness, sensational writers state that the operators make a great amount of money out of their property at the sacrifice of everything that is manly, including the killing of their employes and charging the consumer exorbitant rates for coal.

*Pittsburg, Pa.

The operators are not in a position to contradict this, for what they would say would not be believed, and any statements which they might make could not be put in such vigorous language. Recently a number of yellow journals published articles in connection with the coal-mining industries that are gross fabrications and misstatements of facts. The general reading public, however, absorbs its impressions from the columns of these journals, and they tend to create a feeling of animosity against those who have probably much more than their share of the burden to bear.

The operator is often forced to sell his coal at prices that mean no profit to him. When this occurs it is only a question of time until some person suffers. The operator in dealing with the labor around the mine is oftentimes forced by reason of circumstances, public opinion, or other considerations beyond his control, to pay wages which are not warranted by the price received for his coal.

Another matter which is a serious one to the operator is the position which our government is advocating and which posterity also demands, namely, the conservation of fuel. As conditions exist today, taking for example the Pittsburg district, from 40 per cent. to 60 per cent. of the Pittsburg seam of coal, including as the seam, roof coal and all, is lost in mining, for the reason that the operator could not sell his coal for a price that would be equal to that of the cost of production, and yet the demand is upon him just the same to mine this coal, in order to protect the fuel supply for future generations. Under existing methods of operation, a greater percentage of the recovery of coal cannot be expected or accomplished. It therefore becomes a matter of importance that the government should in some way assist in solving this problem and not place the entire blame and burden on the operator.

A serious problem that confronts the operator is that if he should attempt to join with a fellow operator and form a combination by which the industry could be put on an equitable basis relative to coal production, wages paid, and the price to consumer, he would be haled into court as attempting a combination in restraint of trade. There is no part of the business of producing coal that receives more publicity than the conditions which surround the mine laborer at the mines. There is one condition, however, in which the mine workers have an advantage over the operator, or the consumer, namely, that they are permitted to combine in the form of labor unions and demand a great many favors that the individual worker could not secure. I will not undertake to defend the position that this combination has always been used to the advantage of the worker, but I do say that the fact that they are able to combine in forming unions without any governmental interference is growing stronger in their favor in making and securing demands, which others not being permitted to so combine are not in a position to withstand, but I am of the opinion that if some such combinations were permitted to exist among the operators and the consumers as well, with the additional condition that the government shall be a party to all of these combinations, that the entire industry would then be placed on a much better basis.

I think there are several positions which the government can consistently and with good effect take. I believe the government should take a position in connection with the industry somewhat analogous to the German government in connection with their coal industry. I believe that the government should go further to the extent that they should also permit or demand that the price at which coal should be sold should also be fair and equitable. This can be done by having a commission something similar to the Interstate Commission to review all conditions and controversies and have power to regulate the same through their decision, taking into consideration the cost of production in the various districts and permitting the fixing of a price above this cost that will guarantee to the capital invested a fair return, or they could permit combinations of the operators in the various districts, also a com-

bination of all large consumers who could meet together and take into consideration all the conditions necessary to carry out the requirements made by the government and then fixing their price accordingly. Also granting the commission above mentioned the right to review these prices and if they should be considered exorbitant, or in any way unfair, to have power to reduce them to such an amount as to render them fair and equitable to all concerned.

In conclusion I believe that before the coal industry can be placed on a permanent and equitable basis the present methods of handling the business must be revised. All parties interested therein must deal with this matter in a fair and business-like manner.

采 采

West Virginia Mining Institute

The following is the address of President Frank Haas, delivered before the summer Meeting of the West Virginia Coal Mining Institute, at White Sulphur Springs, West Virginia, June 19 and 20, 1911.

FELLOW MEMBERS:—Were one to chronicle the events of the past half year in the coal industry of West Virginia, he would put forth as the predominating feature the demoralized condition of the coal trade. The severity and continued period of this depression has been remarked by some of our older operators to be the worst they have experienced. The causes of any of these commercial depressions are evidently so entangled in multitudinous conditions that our wisest economists have not yet been able to dissect them.

The present controversy in our National Congress over Canadian reciprocity can have but little effect, and that indirectly, on the West Virginia coal industry. One of our Senators has offered an amendment to the reciprocity bill, the effect of which will be to place Canadian soft coal on the free list whenever the President shall have sufficient evidence that the Canadian duty on American coal is removed. It would be an interesting subject indeed to investigate, free from all political features and localism whether as a whole, this country would be benefited by free coal with Canada. True, some districts would be materially benefited, while some others might suffer. It is stated that statistics show that American coal is imported into Canada largely in excess of Canadian coal imported into this country, the proportion being about 17 to 3. We trust, whatever the legislation, that the most good will come to the greatest number of people.

The recent decision of the Supreme Court on the famous trust cases, particularly that of the Standard Oil Co., and others pending almost as important, seem to have had a reassuring effect on the larger industrial interests of the country. We are told that business conducted with no unreasonable restraint of trade is legitimate, whatever that may mean. The layman can be forgiven, however, if he does not understand a subject or decision about which our wisest counsel cannot agree. The country at large has faith in our courts and we trust that their action will relieve the apparent strain to which this matter has subjected the business interests of the country.

A question of particular interest to West Virginia coal operators, is now in hearing before the Interstate Commerce Commission. This is the demand from the so-called Pittsburg operators for a reduction of freight rates from the Pittsburg district to the lakes. The point really at issue is a further differential against West Virginia coals. The argument is advanced that the cost of operation in the Pittsburg region is greater than that of the West Virginia fields, that their coals cannot be sold in competitive regions at a profit for this reason. I believe that a careful analysis would reveal that their excess of cost is due, not to natural conditions, labor, or materials, but to high fixed charges which they carry on their coal lands. The coal-land speculators of the Pittsburg field have boasted

that the value of coal lands has risen from \$50 an acre to as high as \$3,000 per acre. Evidently some one is confused as to the relative definition as to value and price. Would it be unreasonable to suppose that such profit to which the Pittsburg region operators are justly entitled has been long anticipated and discounted by these speculators in coal lands and has long since been carefully tucked away in their pockets? Should the Interstate Commerce Commission be convinced that a readjustment of freight rates is reasonable or just, the first indication of prosperity for Pittsburg operators will be the glad news that Pittsburg coal lands have again increased in value.

Coal dust is still in the lead of subjects of technical discussion not only in this country but in nearly all foreign countries in which coal mining is an important industry. Some time ago the question of permissible explosives was considered of greatest importance, but for some reason the interest in this has begun to lag. The theory then was that the most important feature in the prevention of coal-dust explosions was to prevent an initial explosion. I should be sorry, indeed, to learn that this is no longer considered as the most important feature. We, and I mean Americans, especially, have yet much to learn about permissible explosives, and, among many others, I am not yet moved to the spirit of implicit faith in the permissible explosives now offered us commercially. The trend of endeavor now seems to be to prevent the propagation of an explosion if once started. Watering, once so universally urged, has apparently been temporarily abandoned and in its place stone dust is highly recommended. It must be borne in mind that most of these rapidly succeeding conclusions emanate mostly from foreign countries, and it is highly essential that we keep before us the relative conditions under which coal is mined in the various countries. For instance, in most European countries the main haulways are in rock tunnels, while ours are in coal, and they do not have the loose end-gate mine cars which are used almost exclusively in this country.

Belgium still pins its faith to permissible explosives and allows no watering; Germany is extravagant in its watering systems, while England and France tend toward the stone dust as a preventative of propagation. Where there is still such a lack of agreement as to the proper remedy I would advise you to keep your mines wet, when you have to shoot, shoot with care, and do not fail to practice eternal vigilance, the lack of which has caused more disasters than all others.

It is gratifying to note that our National Bureau of Mines is still working with the enthusiasm that characterized its beginning. It has had several opportunities within the past year to lend itself to practical rescue work. It is reported that the experimental mine at Bruceton will soon be ready for practical experiments. I do not hesitate to state that this method of taking an actual mine for experimental purposes will prove a great success, not only for verifying some of the conclusions which have been tentatively reached with less accurate methods, but also in the discovery of new things which nothing but the actual combinations of conditions as found in a coal mine can illustrate.

Only a few days ago my attention was called to the fact that a mine explosion had occurred in a mine near Clarksburg, in which there was no open light and the shot which was set off, and coincident in time with the explosion, was discharged by battery from the outside, and the powder used was one of the permissible type passed by the Pittsburg Testing Station. True, the mine contained firedamp, which was well known at the time, but every known precaution had been taken to avoid accident. One man evidently had faith and stood partly in front of the mine opening and was badly burned and had his face shot full of coal. Another incident not quite so recent has come to my notice, where a permissible powder set the mine on fire, possibly in the presence of a small gas feeder.

It is such cases as these that need special investigation, to

find out just what the peculiar conditions were which made them possible. In the first case mentioned the mine was small and no one was in it when the explosion occurred. In the latter case men were present and extinguished the flame before it had time to spread.

West Virginia had but one dust explosion to record during the past year. The unfortunate accident at the Ott mine, on April 24, which cost the lives of some 23 men, was caused, in the opinion of our Chief Mine Inspector, by a shot fired in the solid and that the explosion was propagated through the mine by the presence of dry dust. Whether black powder or Monobel was used was not definitely determined, but Mr. Laing is of the opinion that it was black powder. The fact that there was a battery and wire leading from this shot would indicate a rather unusual method of shot firing if black powder was used.

The former meetings of the institute have been held in the vicinity of the various coal fields in West Virginia, and the change to the White Sulphur Springs was an innovation greatly appreciated by the members. During the business sessions it rained, while during the social sessions the sun shone and then each member sought diversion in his favorite pastime. The meeting was well attended, quite a number bringing their wives and daughters, which added to the gayety. The papers read were discussed intelligently, although it is to be regretted that they could not have been mailed to the members two weeks previous to the meeting. Among those present, the following were recognized: T. H. Huddy, Boomer; A. J. Sting, Guy A. Willey, F. H. Palmer, Chas. Connor, C. L. Hibner, W. H. Daffern, A. B. Cherry, W. L. Alston, C. E. Krebs, I. D. Shaw, A. F. Beck, C. K. West, A. W. Pruitt, J. S. Cunningham, Jas. Martin, of Charleston; D. Howard, Frank E. Parsons, of Clarkesburg; W. B. Crawford, Coalwood; L. W. Snyder, C. Ewart James, Carbon; L. Blankinsopp, Branchland; D. M. Petersen, W. J. Jinks, W. T. Williams, A. Mitchell, Wm. Nicholson, Bluefield; Thos. Pethoski, Eccles; Morris Watts, Eckman; A. E. Reppert, H. W. Hesse, Frostburg; F. Haas, J. C. Evans, R. E. Rightmire, John Thompson, C. H. Tarleton, Fairmont; F. G. Wood, Sullivan; Charlton Dixon, Low Moor, Va.; F. C. Brown, J. J. Echols, Lewisburg; Ernest Chilton, Raleigh; C. M. Fenton, Marting, W. Va.; F. K. Holmsted, Quinimont; R. D. Leach, Hotcove; Louis Nahodil, W. E. Smith, E. W. Riley, John McMillan, Layland; G. H. Balen, Ethel; E. P. Connell, G. B. Lee, J. W. Herron, P. A. Grady, Jas. Clark, D. R. Phillips, J. C. Miller, W. M. Shaul, Huntington; R. S. Ord, Maybeury; J. C. White, Morgantown; M. Hanford, Powellton; Wm. Laing, D. B. Evendall, McCalpin; E. B. Day, R. G. Johnson, W. L. Walker, Ed. Kerchner, G. W. Mingus, Creighton Dilworth, D. Hunter, Jr., H. C. Owen, W. B. Spellmire, B. G. Fernald, G. R. Wood, F. C. Albrecht, W. A. Thomas, J. W. Paul, Clarence Hall, Pittsburg, Pa.; H. W. Black, J. A. Lay, Thurmond; J. C. C. Mayo, Paintsville, Ky.; G. L. Hart, W. W. Coy, Roanoke, Va.; E. W. Parker, Washington, D. C.; F. W. Parsons, New York City; E. B. Wilson, Scranton, Pa.

來 來

Mine Inspectors' Annual Meeting

The following is the address of Geo. Harrison, President of the Mine Inspectors' Institute of the United States of America, at their Third Annual Meeting, held at Charleston, W. Va., June 13, 1911.

FELLOW MEMBERS:—Since our last gathering the usual number of lives have been sacrificed in the mines of this country, and, in consequence, the customary number of wives, children, and dependents have been called on to mourn the untimely end of their breadwinners.

A year ago we prided ourselves on the establishment of a Federal Bureau of Mines, and the enactment of more adequate

mining laws in various mining states, and many of us were buoyant with hope that the fatalities in mines would be materially reduced in consequence of added safeguards.

The number of lives lost from gas and dust explosions and other causes classed as mine calamities may not have been so great, but the number of individual fatalities seems to have more than kept pace with the ever increasing production of coal, and we are still confronted with the unsolved and important problem of how to accomplish the prime object which prompted the establishment of our Institute.

A careful investigation of the causes leading to fatalities in the mines in Ohio shows that over 80 per cent. of all fatalities are avoidable, and would not occur if employes and the management of mines were more obedient to the requirements of laws and more disposed to a strict performance of duty. Lack of discipline is, to a great extent, the secret of the high death rate in our mines, compared with that of older mining countries where greater responsibility is imposed on the management of mines, and where inside foremen have sufficient help to insure not less than two visits each day to every miner under his jurisdiction. During these visits time is taken to see that working places are properly timbered, dangerous roof secured at the proper time, and miners not permitted to work under it. The orders of the mine foreman or superintendent, in regard to the safety of working places and general security, are as binding as statutory law, and quick punishment for violations always follows. There is no disposition to aid each other in dangerous violation of law and orders given by the management, and, in consequence, prompt prosecution of offenders has a very beneficial effect in the way of lessening the number of fatalities.

One of the objects of our institute was to exercise our influence to make the Mining Departments in the various mining states institutions of efficiency, relieving the inspectors of any political obligation that would embarrass them in the enforcement of laws and protection of life and property in the mines. Judging from the many changes of mine inspectors that have recently taken place in a number of State Mining Departments, there has not been much progress made in eliminating politics. The State Mining Department, the miners and mine operators, of Ohio are all deeply indebted to Governor Harmon for his insistence that where so many lives are at stake political influence must have no consideration in the ability and faithful performance of duties of inspectors.

I call attention to the fact that we are not deriving the benefit that most of us expected, in an educational way, from our annual meetings. Much of our time is consumed in ways other than in discussions of important subjects pertaining to every-day occurrences in mines, which unnecessarily fill our cemeteries and graveyards and leave women and children helpless and dependent upon others.

It is true that many intelligent and well-prepared papers on subjects of first importance are either hurriedly read to the institute or submitted to the secretary without reading, and we have no opportunity even to read them until another shower of annual subjects crowds them out of our memory; the greatest benefits to be derived from these papers read at our meetings is the logical, practical discussion of their merits and demerits; a frank, free but friendly criticism of their strong and weak points that will not only benefit our own membership, but that we can support and maintain against all illogical opposition.

In conclusion I desire to say to the practical mine inspectors, especially those who are still on the sunny side of life, "Don't think you know it all, learn all you can about mining matters, but let me implore you, remember that upon you and those connected with the management of mines under your jurisdiction and the judicial but rigid manner in which you enforce the law, depend the lives and health of those underground."

Answers to Examination Questions

Selected Questions of the Pennsylvania Anthracite Mine Inspectors' Examination, at Scranton, Pa., May 25, 26, 1911

Bu J. T. Beard

NOTE.—The following questions, selected from the examination, are here numbered consecutively.

QUES. 1.—What principle or rule should be followed in interpreting or construing the law in reference to mining?

ANS.—All law should be interpreted or construed in harmony with itself, and in accordance with the plain and evident intention of the statute whether expressed or implied. In case of ambiguity or reasonable doubt, the matter should be referred to the attorney-general for his interpretation, as the legal advisor of the state.

QUES. 2.—What are the duties of the mine inspector?

ANS.—It is the duty of the mine inspector to enter and carefully inspect, as often as required, each working mine in his district, and see that it is being operated in compliance with the law, and that all machinery and appliances in use are safe, and the airways, roads, passageways, and working places maintained in a safe and healthful condition with respect to ventilation, drainage, timbering, mining of coal, etc. It is his duty to make any inquiry that is designed to acquaint him with the true condition of the mine and its entire equipment, with respect to the health and safety of all persons employed in or about such mine. The inspector must keep a correct record of all visits made to the mines in his district, showing the condition of the mine, quantity of air in circulation, dangers found, changes suggested, etc. He must carefully investigate all fatal mine accidents, and attend inquests, examine witnesses, and record the facts as he finds them.

QUES. 3.—What are the duties of workmen in general employed in and about mines, in relation to any threatened danger?

ANS.—Any person, immediately on discovering any threatened danger in or about a mine, should promptly give the alarm and notify the mine officials.

QUES. 4.—How are the coal mines of Wayne, Susquehanna, and Sullivan counties rated, in respect to their being fiery mines or not?

ANS.—They are generally non-gaseous mines.

QUES. 5.—What are the principal dangers to which mine employes are exposed in these counties?

ANS.—Falls of roof and coal, movement of cars, machinery in breakers, explosion of powder, contact with live wires, mine fires, mules, etc.

QUES. 6.—Name the different systems of mining coal.

ANS.—Stripping or open-cut mining, room-and-pillar system, panel system, buggy system, single and double chutes, rock chutes, cross-tunnels, and long-wall system.

QUES. 7.—What is the greatest number of veins of coal in any locality in Wayne, Susquehanna, and Sullivan counties?

ANS.—The greatest number in the counties named probably occurs at Forest City, Susquehanna County, where borings by the Hillside Coal and Iron Co. showed a total of 12 coal seams, only five of which, however, were of workable thickness, varying from 2 feet 2 inches to 5 feet 2 inches thick.

QUES. 8.—After the headings have been driven beyond the shaft pillars, what method should be adopted to work the coal?

ANS.—This will depend wholly upon conditions. A large output and available funds, or a gaseous seam, may make advisable the employment of the triple-entry system. The character of roof, floor, and coal, thickness and depth of seam, and quantity of waste material to be handled will generally determine the size of entries and the width of chambers and pillars.

QUES. 9.—What gases are found in coal mines?

ANS.—The common mine gases are marsh gas, or methane (CH_4), carbon dioxide (CO_2), carbon monoxide (CO), hydrogen sulphide (H_2S), and olefiant gas (C_2H_4).

QUES. 10.—What quantity of pure air is required in coal mines for men, mules, lamps, and the deflagration of powder?

ANS.—A sufficient quantity to make all working places and passageways safe and healthful for men to work in them. This, however, will vary widely in different mines, depending on the quantity and kind of gas generated, the thickness of the seam as determining the size of openings; quantity and kind of powder burned, quality of oil used in lamps, and other like conditions affecting the mine atmosphere. It is common practice to allow 200 cubic feet of air per minute per man in all mines in the anthracite regions of Pennsylvania. A mule generally requires from five to six times the quantity of air allowed for a man.

QUES. 11.—(a) What is the maximum velocity of air allowed by law, in mines generating large quantities of explosive gas? (b) What is the reason for this maximum being so fixed?

ANS.—(a) The anthracite mine law forbids a greater velocity of the air-current than 450 feet per minute. (b) The reason for this limitation is that the unbonneted Clanny lamp, so much used in these mines, is unsafe in a current velocity exceeding 480 feet per minute.

QUES. 12.—What are the symbols and specific gravities of hydrogen, nitrogen, oxygen, and carbon?

ANS.—Hydrogen, symbol H , specific gravity referred to air of the same temperature and pressure, .06926; nitrogen N , .9713; oxygen O , 1.1056; carbon C . Carbon occurs in a number of allotropic forms, as diamond, graphite, coal, charcoal, lamp black, etc., all of which have different specific gravities, varying from 3.5 to .24. By experiments on the burning of diamonds in oxygen the combining weight of carbon, or its density referred to hydrogen as unity, has been determined as 12.

QUES. 13.—What is the symbol and specific gravity of carbonic acid gas, and how may its density be calculated?

ANS.—Carbonic acid gas (carbon dioxide), symbol CO_2 ; specific gravity, referred to air of same temperature and pressure, 1.529. The density of any gas referred to hydrogen as unity is always one-half its molecular weight. For carbon dioxide (CO_2), the molecular weight is $C=12$, $O=16$; hence, $CO_2=12+2\times 16=44$. The density of this gas is therefore $44\div 2=22$.

QUES. 14.—What is the symbol, combining weight, and density of light carbureted hydrogen gas?

ANS.—Light carbureted hydrogen (methane or marsh gas), symbol CH_4 . The molecular weight is, $C=12$, $H=1$; hence, $CH_4=12+4\times 1=16$. The density of this gas is then $16\div 2=8$. We cannot speak of the combining weight of a compound, but only of elements. The molecular weight of any compound is always equal to the sum of the combining weights of its constituent atoms.

QUES. 15.—What is the symbol, combining weight, and density of carbonic oxide gas?

ANS.—Carbonic oxide (carbon monoxide), CO ; molecular weight, $C=12$, $O=16$; hence, $CO=12+16=28$. The density of this gas is therefore $28\div 2=14$.

QUES. 16.—What can you say of the affinities of oxygen and nitrogen, respectively, for other elements or matter in nature?

ANS.—Oxygen has a very strong affinity for most of the known elements, combining with them at all temperatures to form oxides; while nitrogen, on the other hand, is exceedingly inert, combining directly with but few of the elements.

QUES. 17.—(a) What proportion of air mixed with marsh gas (CH_4) will render the mixture explosive? (b) Describe the effect of mixing air with gas in different proportions.

ANS.—(a) When air is mixed with marsh gas the mixture first becomes explosive when the proportion of gas and air is

in the ratio of 1 to 5. (6) The effect of adding air to marsh gas is as follows: The mixture first becomes inflammable when the proportion is one volume of gas to 2.39 volumes of air. At first the mixture burns quietly, but as more air is added the gas snaps and crackles and finally reaches the explosive point when the proportion is one volume of gas to five volumes of air. As more air still is added the violence of the explosion increases and reaches a maximum when the proportion is one volume of gas to 9.57 volumes of air. The further addition of air beyond this point diminishes the violence of the explosion, which ceases altogether when the proportion is one volume of gas to 13 volumes of air. The mixture, however, is still inflammable and remains so till the proportion reaches one volume of gas to 17 volumes of air, when the flame dies out.

QUES. 18.—What is the least percentage of gas in a fire-damp mixture that will explode?

ANS.—The proportion of gas and air at this point is 1:13. The percentage of gas in this mixture is $\frac{1}{1+13} \times 100 = 7.14$ per cent.

QUES. 19.—What is the percentage of gas in a firedamp mixture at its most explosive point?

ANS.—The proportion of gas and air is then 1:9.57; and the percentage of gas is $\frac{1}{1+9.57} \times 100 = 9.46$ per cent.

QUES. 20.—What is the percentage of gas in a firedamp mixture, at the point where the addition of more air renders the mixture inexplorable?

ANS.—The proportion of gas and air is then 1:13; and the percentage of gas 7.14 per cent., as given in reply to Ques. 18.

QUES. 21.—What are the mixtures of air and gases immediately before and immediately after an explosion called?

ANS.—The mixture of air and gases before explosion is very variable in composition; it is called firedamp. The mixture of gases remaining after an explosion has taken place is likewise very variable; it is called afterdamp.

QUES. 22.—In case of explosion how would you proceed to rescue any workmen who might still be alive in the mine?

ANS.—Everything would depend on the extent and violence of the explosion, and the damage done to the ventilating and hoisting machinery and the mine openings. Necessary repairs must be made as quickly as possible in order to reestablish a reliable ventilating current. While this is being done volunteers must be chosen of the most experienced men, and these must be equipped with lamps and tools. The mine must be entered by following the intake current. Only safety lamps must be used, and the condition of the mine air must be constantly observed by examining the flame of the lamps, and by noting the effect produced on caged mice and birds, which should be kept on hand at all mines ready for such use. Air-stoppings and doors must be repaired and temporary brattices built sufficient to conduct the air forward and enable the rescuers to proceed.

QUES. 23.—What process should be adopted for the resuscitation of persons suffering from asphyxia or the effects of afterdamp?

ANS.—Asphyxia describes the condition that results from a cessation of respiration by which air is taken into and again expelled from the lungs. This may be caused by an obstruction of the windpipe, or the inhaling of some gas that will not support life and which, by filling the lungs, excludes the necessary oxygen on which life depends. In addition to such suffocating gases as carbon dioxide and nitrogen, mine afterdamp may contain poisonous gases, carbon monoxide being most frequent. To overcome these effects, remove the person promptly to an atmosphere of good air; loosen any tight clothing, and proceed to produce artificial respiration as follows: Place patient on his back with a bundle of clothes under his shoulders to ele-

vate and expand the chest. Kneel at the patient's head and bending forward grasp his forearms firmly below the elbows, and draw them outward and upward as far as they will go above the head; hold them there for a second, giving time for the lungs to expand and draw in some air under this action; then bring them down and press the arms against the sides and chest in such a manner as to compress the lungs and drive out the air inhaled. Hold them in this position for a second; and continue to repeat this operation for an hour, or until the patient begins to breathe. The rate of inhalation and exhalation should be about 15 times a minute. In the meantime keep patient warm with blanket; apply ammonia to handkerchief and hold under his nose. When breathing is restored rub the limbs toward the heart to assist the flow of venous blood back thereto. Give rest and keep warm with hot-water bottles, and allow plenty of fresh air by open windows after patient has been put to bed.

QUES. 24.—Name the instruments used in connection with the working of coal mines.

ANS.—Anemometer, water gauge, barometer, thermometer, hygrometer, safety lamp and indicator for measuring gas, miners' compass, and measuring tape.

QUES. 25.—How many kinds of thermometer scales are there, and which of these is commonly used in this country?

ANS.—Three, the Fahrenheit, Centigrade, and Reaumur. The Fahrenheit scale is in common use here.

QUES. 26.—Describe the Fahrenheit thermometer.

ANS.—The thermometer is a glass tube with capillary bore, closed at one end, and having at the other end a glass bulb filled with mercury. Any rise or fall of temperature causes an expansion or contraction of the mercury, which rises and falls in the tube in a corresponding manner. A graduated scale attached to the tube measures the height of the mercury, and is calibrated to mark the temperature in degrees. All thermometer scales are calibrated by reference to two fixed points, namely, the temperature of melting ice and that of boiling water, at sea level. In the Fahrenheit scale the temperature of melting ice is marked 32 degrees, while that of boiling water, at sea level, is 212 degrees; giving, therefore, 180 degrees between these two points in this scale.

QUES. 27.—Describe the Centigrade thermometer and its graduation.

ANS.—The general description of the thermometer is the same as that given in answer to Ques. 26; but in the Centigrade scale the temperature of melting ice is marked 0 degrees, while that of boiling water is 100 degrees; thus giving 100 degrees between the same two fixed points in the Centigrade scale.

QUES. 28.—Describe the graduation of the Reaumur thermometer.

ANS.—In the Reaumur scale the temperature of melting ice is marked 0 degrees, as in the Centigrade; but the temperature of boiling water is made 80 degrees, thus giving only 80 degrees between these fixed points in this scale.

QUES. 29.—What are the readings on the Centigrade and the Reaumur thermometers corresponding to 100 degrees on the Fahrenheit scale?

ANS.—Centigrade = $\frac{5}{9} (100 - 32) = 37\frac{1}{9}^{\circ}$.

Reaumur = $\frac{4}{9} (100 - 32) = 30\frac{2}{9}^{\circ}$.

QUES. 30.—What is the atmosphere and what are its principal ingredients?

ANS.—The atmosphere is the aerial envelope that surrounds the earth. Its chief ingredients are oxygen and nitrogen, with small quantities of carbon dioxide, ammonia, argon, and water vapor.

QUES. 31.—Is the composition of the air always the same on the surface and in the mines?

ANS.—The composition of free air, on the surface, is practically always the same. Mine air generally contains a trifle less oxygen and somewhat more carbon dioxide than atmospheric air, besides often other mine gases in varying quantities.

✻

Correspondence

✻

Rolling Friction

Editor Mines and Minerals:

SIR:—In the June number W. C. A. says: "Some people maintain that the resistance due to rolling friction of mine cars is greater in summer than in winter." In a catalog of a large concern is this sentence: "The resistance is greater in winter." Your correspondent asked which statement is correct and the reasons.

Both statements are correct if the term "rolling friction" is used in its proper sense. The first statement refers then to rolling friction, while the second refers to the combined friction of the entire locomotive.

Rolling friction is the resistance that a rolling body meets from the surface on which it rolls, as, for instance, the resistance offered a car wheel that is rolling on a rail. The rolling frictional resistance offered to the movement of a car along a track is greater in summer than in winter, but not directly on account of the difference in temperature. In the winter the ground is frozen and the rail, consequently, is held more rigid. In summer there is a greater movement of the ties, and consequently to the rails, as the car moves over them. This all tends to increase the force necessary to keep the car moving along the rail, and is applicable to surface roads in cold countries. On the other hand, the temperature of a mine does not vary greatly in winter and summer, so the effect would not be very marked so far as rolling friction is concerned.

It is possible, however, that your correspondent referred to the journal friction, which is a sliding friction and is dependent on the lubricant used. If the query refers to the resistance due to the journal turning in the box, that is a different matter and will come under journal friction.

The second statement that "the resistance is greater in winter" refers to journal friction and is true until the bearings become heated up to the normal working temperature. If the car has been standing in cold weather long enough for the journals to cool to the weather temperature, the frictional resistance offered to the movement of the car will be increased. The car will move stiffly and it will be harder to get up to speed. Once a trip of such cars has been running sufficiently long to heat all the bearings to the normal, the bearing friction will reduce to about normal. However, bearings that do not have sufficient movement to cause them to heat up to summer temperature will exert considerably more friction in winter than in summer.

To compensate this it is usual to lubricate with oils suitable for summer and winter, known as summer and winter oils. Such oils have the same viscosity; that is, the same power for adjacent layers to adhere together, but vary in their "body." It is the body of the oil that regulates the thickness of the layer intervening between the journal and its bearings, and the body of an oil changes with the temperature, becoming thickened with cold and thinned with heat.

The object of using a lubricant on a journal is to reduce the amount of friction by floating the journal bearing on a film of the lubricant interposed between it and the journal. The function of the lubricant is to prevent the bearing from coming into metallic contact with the journal. If the oil has not sufficient viscosity, it will be squeezed out, and therefore cannot keep the surfaces of the journal and the box apart. This will greatly increase the journal friction. If the lubricant has not sufficient body, the film of lubricant interposed between the journal and the bearing will be so thin that the journal will not be completely separated from the bearing at all points. The friction in this case will be due partly to fluid friction and partly to metallic friction, due to the metal of the journal coming into contact with that of the bearing at points.

The journal has a certain normal working temperature in the winter, and the body of the oil must be sufficient to give a film of oil of a thickness that will completely separate the journal and its bearing. The normal temperature of a journal in the summer time is higher than in the winter, but if the lubricant has the proper body it will give the same thickness of film in the summer as in the winter; however, the tendency in the summer is for the increase in temperature to reduce the body of the lubricant, and, therefore, the thickness of the film that it will interpose between the journal and its bearing. The tendency in the winter due to the temperature lowering is to increase the body, and, therefore, the thickness of the film.

Any mistake made in the quality of the oil will show up worse in the summer than in the winter, because the increased temperature tends to magnify the trouble. From this it will be seen that the journal friction in summer is very apt to be more and to cause greater trouble than in winter if the proper oil is not used. It is possible that your correspondent meant this when he referred to rolling friction.

J. F. COSGROVE

Filter Presses

Editor Mines and Minerals:

SIR:—My attention has just been called to Mr. Broadwater's communication in your June issue, in which he rather takes to heart my reference to filter-press practice in my article in your May issue, and, I think, almost misses my point.

Mr. Broadwater is in the filter-press business and naturally is sensitive on the subject, but the fact remains that the use of the vacuum filter has so far outstripped the filter press for recovering the pregnant solution from the cyanided slime that filter pressing is now hardly a competitor of the vacuum type of filter.

We admit the excellent work of the Homestake filter-press plant, the remarkably low costs, and the unusually high efficiency of operation, but the Homestake is really no criterion, because it, next to the Alaska-Treadwell, is the lowest grade gold ore in the world to be treated profitably, and is an unusual case.

Mr. Broadwater advises me to go to Blair to see the Silver Peak mill, where three filter presses treat 480 tons per day. I have seen the mill. Just over the Montezuma range from Silver Peak are Goldfield and Tonopah, where the Goldfield Consolidated, Goldfield Florence, Tonopah Extension, Montana-Tonopah, and Belmont are all using vacuum filters with a combined capacity of about 2,500 tons per day.

To quote from his communication: "If anything further were needed to show that Mr. Barbour's statement is misleading, it will be found in the following list of orders for filter presses placed with this company in the last year." Now the fact that the orders for filter presses in the past year have a total capacity of 2,100 tons per day seems to me to prove the correctness of my statements. The total capacity of vacuum filters ordered during the past year would make this 2,100 tons look small and insipid.

I have before me a letter from Mr. G. C. Patterson, vice-president of the Butters Patent Vacuum Filter Co., in which he states that in a little over a year he, himself, has sold nine filter plants with a total of 1,946 leaves, and a total capacity of about 6,000 tons per day. The various other vacuum-filter companies are busy adding to these figures. The more we go into the matter the narrower looks the filter press field and the broader looks the vacuum filter field. Therefore, I cannot admit that my statement was misleading.

PERCY E. BARBOUR,

Tecoma, Nev.

Mining and Metallurgical Engineer

✻ ✻

Manganese ore is being mined in South Africa, near Cape Town, and several hundred thousand tons have been shipped to Antwerp. Most of the ore is higher in phosphorus than is used in the United States.

An Outline of Mining

Suggestions for the Arrangement of a Course Covering Mining Appliances and Mining

By Will H. Coghill*

The accompanying outline is intended to cover the subject of mining appliances and mining. It is submitted for publi-

cation with the thought that it may be of some assistance to the young instructor who has to arrange lecture courses in mining and aid the young mining engineer who wishes to institute a card indexing system on a small scale and capable of development. The outline is the result of an investigation of the subjects treated in all the available textbooks on mining, bulletins of the United States Geological Survey, and Bureau of Mines, and articles in the mining journals and machinery catalogs.

OUTLINE OF MINING

- | | | |
|---|--|---|
| <p>A. Hoisting.</p> <ol style="list-style-type: none"> 1. Hoists. <ol style="list-style-type: none"> (a) Man power. <ul style="list-style-type: none"> Windlass. Crab or hand winch. (b) Horsepower. <ul style="list-style-type: none"> Whip. Whim. (c) Steam power (air, electric). <ul style="list-style-type: none"> Geared. Friction. Spur and pinion. First motion. Single rope. Counter balanced. Reels. Drums. <ul style="list-style-type: none"> Conical. Cylindrical. Koepe and Whiting systems. (d) Pneumatic hoisting. (e) Man engine. 2. Ropes. <ol style="list-style-type: none"> (a) Vegetable fiber. (b) Steel. <ul style="list-style-type: none"> Parallel wires. Twisted wires. Round (cylindrical and conical). Ordinary lay. "Lang" lay. Flat. 3. Sheaves. 4. Carriers. <ol style="list-style-type: none"> (a) Bucket or tub. (b) Skip. <ul style="list-style-type: none"> Inclined. Vertical. (c) Cage. 5. Head-frame. <p>B. Haulage.</p> <ol style="list-style-type: none"> 1. Hand trucking. <ol style="list-style-type: none"> (a) On track. (b) Mono-rail. 2. Animal power. 3. Motors. <ol style="list-style-type: none"> (a) Stationary. <ul style="list-style-type: none"> Inclined plane. Endless-rope system. Tail-rope system. (b) Traction. <ul style="list-style-type: none"> Air. Single expansion. Two-stage. Electric. 4. Aerial tramway. <ol style="list-style-type: none"> (a) Single rope system. (b) Two-rope system. <p>C. Drainage.</p> <ol style="list-style-type: none"> 1. Motive power at surface. <ol style="list-style-type: none"> (a) Air lift. (b) Lift pump. <ul style="list-style-type: none"> Cook steam head. Balance bob. (c) Force or Cornish pump. (d) Bailing tanks. (e) Pulsometer. (f) Hydraulic ram. 2. Motive power underground. <ol style="list-style-type: none"> (a) Reciprocating pump. <ul style="list-style-type: none"> Piston or inside packed pump. Plunger or outside packed pump. (b) Rotary pumps. (c) Centrifugal pumps. <p>D. Ventilation.</p> <ol style="list-style-type: none"> 1. Mine gases. 2. Breathing apparatus. <ol style="list-style-type: none"> (a) Stationary type. (b) Portable type. <ul style="list-style-type: none"> Oxygen-regenerative apparatus. Solid regenerators. Helmet type. <ul style="list-style-type: none"> Draeger. Fleuss-Siebe-Gorman. Wer. Mouthpiece type. <ul style="list-style-type: none"> Westphalia. Liquid regenerator. Tissot apparatus. Aerolith (liquid air). Pneumatogen. | <ol style="list-style-type: none"> 3. Ventilating Systems. <ol style="list-style-type: none"> (a) Natural. (b) Artificial. <ul style="list-style-type: none"> Furnace. Fans. Blowers. Turbo blowers. E. Illumination. <ol style="list-style-type: none"> 1. Stationary illuminators. <ol style="list-style-type: none"> (a) Reflected daylight. (b) Electric. (c) Gas. 2. Portable illuminators. <ol style="list-style-type: none"> (a) Candles. (b) Torches. (c) Lamps. <ul style="list-style-type: none"> Electric. Safety. Acetylene. F. Preservation of mine timbers. <ol style="list-style-type: none"> 1. Brush treatment. <ol style="list-style-type: none"> (a) Creosote. (b) Carbolineum. 2. Open-tank treatment. <ol style="list-style-type: none"> (a) Creosote. (b) Zinc chloride. (c) Sodium and magnesium chloride. 3. Closed-cylinder treatment. <ol style="list-style-type: none"> (a) Creosote. (b) Zinc chloride. G. Boiler water and treatment. <ol style="list-style-type: none"> 1. Precipitation in boiler. <ol style="list-style-type: none"> (a) Aluminum plates. (b) Chemicals. 2. Purification by softening. <ol style="list-style-type: none"> (a) Continuous treating and filtering. (b) Intermittent treating and settling. H. Acquiring mining land. <ol style="list-style-type: none"> 1. Government subdivision. 2. Lode claim. 3. Placer claim. 4. Tunnel site. 5. Mill site. I. Exploration. <ol style="list-style-type: none"> 1. Trenching. 2. Test pit. 3. Dipping needle. 4. Magnetometer. 5. Swedish mining compass. 6. Boring. <ol style="list-style-type: none"> (a) Percussion. <ul style="list-style-type: none"> Churn drill. Percussion core drill. (b) Hydraulic. <ul style="list-style-type: none"> Hydraulic rotary drill. Jetting method. (c) Abrasive core drill. <ul style="list-style-type: none"> Diamond drill. Calyx drill. Chilled shot. 7. Surveying bore holes. J. Exploitation. <ol style="list-style-type: none"> 1. Open work. <ol style="list-style-type: none"> (a) Placer mining. (b) Excavating by water. <ul style="list-style-type: none"> Water as solvent. Salt mining. Sulphur mining. Water as loosener—hydraulic mining. (c) Excavation under water. <ul style="list-style-type: none"> Suction dredge. Bucket. Dipper. (d) Open-cut mining. <ul style="list-style-type: none"> Hand work. Scraper. Steam shovel. Milling method. 2. Underground work. <ol style="list-style-type: none"> (a) Tunneling. (b) Shaft sinking. <ul style="list-style-type: none"> Vertical. Boring. Drilling and blasting. Freezing. Drop-shaft. Inclined. | <ol style="list-style-type: none"> (c) Coal mining. <ul style="list-style-type: none"> Longwall. Retreating. Advancing. Pillar-and-room. (d) Metal mining. <ul style="list-style-type: none"> In thin veins. Underhand stoping. Overhand stoping. In thick veins and masses. Pillar-and-room. Square-set. Filling system. Caving system. <p>K. Breaking ground.</p> <ol style="list-style-type: none"> 1. Air compressors. <ol style="list-style-type: none"> (a) Hydraulic. (b) Mechanical. <ul style="list-style-type: none"> Reciprocating. <ul style="list-style-type: none"> Straight line. <ul style="list-style-type: none"> Simple steam, single-stage air. Simple steam, compound air. Compound steam, compound air. Duplex type. <ul style="list-style-type: none"> Belt driven. Duplex air. Compound air. Direct driven. <ul style="list-style-type: none"> Duplex steam, duplex air. Duplex steam, compound air. Compound steam, compound air. Rotary. <ul style="list-style-type: none"> Turbocompressor. 2. Drills. <ol style="list-style-type: none"> (a) Coal mining. <ul style="list-style-type: none"> Hand work. Pick machine. Endless chain cutters. Breast machine. Longwall machine. (b) Metal mining. <ul style="list-style-type: none"> Hand drilling. <ul style="list-style-type: none"> Single handed. Double handed. Machine drilling. <ul style="list-style-type: none"> Steam drills. Air drills. <ul style="list-style-type: none"> Piston type. Hammer type. Electric drills. Electric-air drills. Hydraulic rock drills. Drill sharpeners. Rock drill bits. 3. Blasting. <ol style="list-style-type: none"> (a) Charging holes. <ul style="list-style-type: none"> Prolonged pressure. Lime. Plug and feather. Hydraulic cartridge. Sudden pressure. Low explosives. <ul style="list-style-type: none"> Gunpowder. Black blasting powder. High explosives. <ul style="list-style-type: none"> Without dope. <ul style="list-style-type: none"> Nitrocellulose or gun cotton. Nitrostarch. Nitroglycerine. Picric acid. Fulminate of mercury. Explosive gelatin. With dope. <ul style="list-style-type: none"> Inactive dope. Active dope. Dynamite. Gelatin dynamite. (b) Firing holes. <ul style="list-style-type: none"> Squibs. Fuse. <ul style="list-style-type: none"> Tape fuse. Electric fuse. Instantaneous. Delay-action. Detonators. |
|---|--|---|

* Northwestern University, Evanston, Ill.

ORE MINING AND METALLURGY

A Twentieth Century Cyanide Plant

Process and Machinery for Treatment of 400 Tons of Silver-Bearing Ores in 24 Hours

By Chas. E. Christensen, M. E.

In discussing a modern cyanide plant it is assumed that the ore carries silver and that the pulp requires about 36 hours to be leached from silver. It will further be assumed that electric current can be secured, transformed to the proper voltage, and distributed from the main switchboard to the motors, which will be so arranged as to give unit drives to the different sections of the plant. A separate crushing plant of double the capacity required will be installed so that it need run during the daytime only. The cyanide plant is assumed to treat about 400 tons of ore per day of 24 hours.

The process and the machinery required would then be as follows: The ore is taken from the mine in steel cars and dumped into large ore bins in the crusher building. From here the ore is drawn through an ore-bin gate into a large Gates breaker set to crush all the ore to pass a 3-inch ring. The product is discharged to two continuous bucket elevators which elevate and deliver the ore into two large iron-frame revolving screens having 2-inch perforations. These revolving screens have no shafts, spiders, or any other obstruction to wear out or impede the free passage of the material to the discharge openings. They run on rollers and are driven through a bevel wheel attached to the periphery of the discharge end of the screen. This meshes with a bevel gear on a counter shaft. The product passing through the 2-inch perforations is delivered directly to two belt conveyers and conveyed to the mill building. The rejections from the screens, or material which will not pass the 2-inch perforations, is spouted into two smaller Gates breakers. These breakers reduce the rejections to 1½-inch size and finer, and discharge the product to the same conveyers that receive the material from the screens. These conveyers have carrying belts 14 inches wide and, if necessary, could be designed to travel up an incline of about 20 feet per 100 feet of length.

At the entrance to the mill building these belt conveyers discharge the ore to two other conveyers of the same type and size, but operating in a horizontal plane right and left. These conveyers are provided with automatic trippers or distributors which travel the whole length of the ore bins and

deliver the ore automatically into the bins which are located behind the stamp batteries.

At the point where the crusher building conveyers discharge into the mill building conveyers, a Cole automatic sampling device is placed to take samples of the crushed ore. The arrangement of this ingenious sampler is such that a sample scoop is made to pass through the ore stream and take a sample across the full width of the belt during its passage. By properly adjusting the driving mechanism the frequency of sampling can be regulated.

The crushed ore is drawn from the battery bins into automatic feeders, Fig. 2, which are of the suspended or hanging type arranged to be moved back from the mortars when necessary, thus giving a large working space for making repairs. There is one ore-bin gate for each five-stamp battery. Forty stamps are needed, each weighing 1,050 pounds. They are arranged in eight batteries of five stamps each, driven by belts with tighteners from the line shaft. The batteries are made

right and left hand and set in three-post frames. The mortars, one for each five stamps, are of the Allis-Chalmers narrow, rapid-crushing, quick-discharge type, provided with four-mesh screens. The principal battery parts are made of steel to insure maximum wearing life. The pulp from each five-stamp battery is delivered to a cone classifier, which makes two products. The spigot or coarse product of each is spouted to a concentrating table and the overflow from each

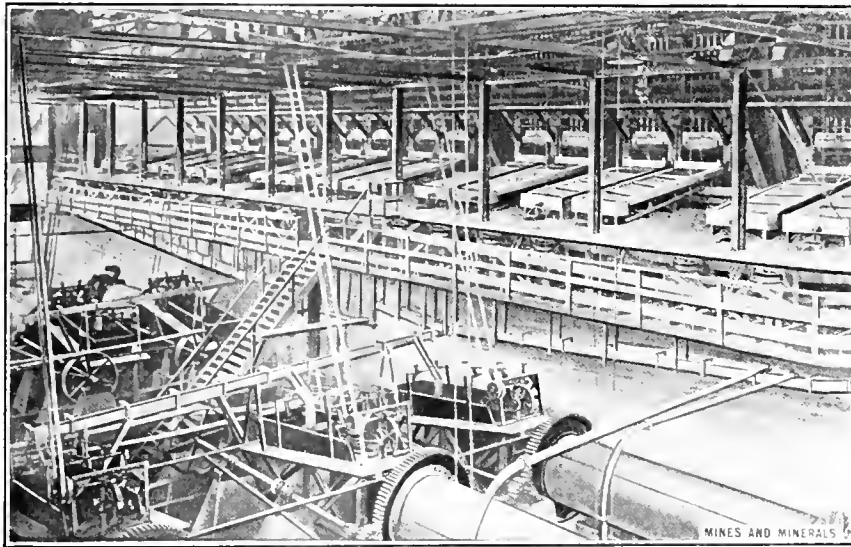

FIG. 1. BATTERY AND TUBE-MILL FLOOR OF CONCENTRATING MILL

cone is delivered to a classifier. The tailings from the eight table concentrators are also elevated to the classifiers by belt and bucket elevators one for each five stamps.

On the classifiers the sand and the slime are mechanically separated. The classifiers separate that part of the pulp crushed to 150-mesh size and it is then delivered to the thickening cones for concentration on vanners.

The coarse sand product from the classifiers is discharged into four trunnion-style, wet-grinding, spur-gear driven tube mills. These mills may be arranged with silix flint brick linings, 4 inches thick, or with El Oro linings. The initial charge of pebble stones for each mill is 10 tons.

The sand is ground to 150 mesh or finer in these mills, each discharging its product into a classifying cone for the purpose of separating from the product any sand which may have passed through the mills without being ground fine enough, and this sand is returned to the classifiers to be fed again to the tube mills. The finished product is delivered to spiral sand pumps by which it is elevated to four large pulp thickening or settling cones, where any excess of water is removed and forwarded to the cyanide plant. The thickened pulp from the

bottom discharge is conveyed to Frue vanners. This type of concentrator has an endless rubber belt with turned up flanges on the edges so as to form a plane inclined rubber surface. The belt travels up the incline and around a lower drum, which dips into a water tank in which the mineral is washed off and collected. In addition to the travel the belt receives a side shake from a crank-shaft along one side, the shake being at

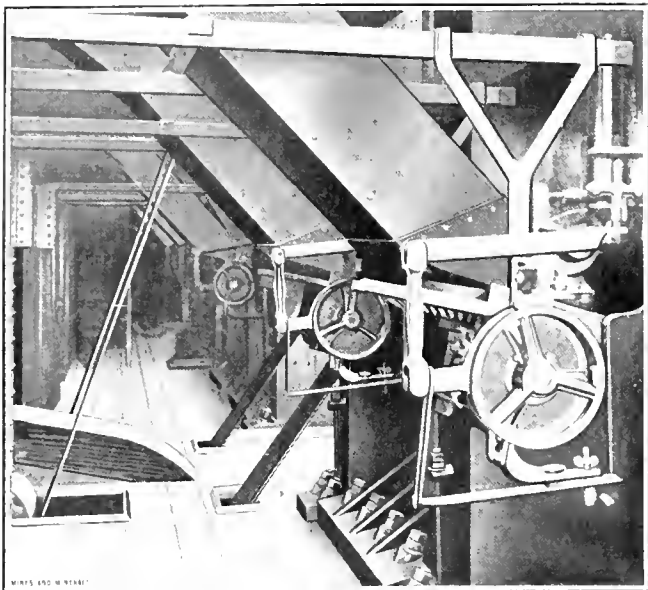

FIG. 2. AUTOMATIC FEEDERS

right angles to the travel of the belt. The pulp is fed on the belt about 3 feet from the head and flows down the incline subjected to the steady shaking motion which deposits the mineral on the belt. At the head of the belt is placed a row of water jets which wash back the lighter sand, allowing only the heavy mineral to pass and become deposited in the water tank below as already mentioned. The concentrated product is collected and dried, after which it is shipped to the smelters.

The tailings from the vanner and the overflow from the settling cones are delivered to any one of six dewatering tanks in the cyanide plant. These tanks are provided with filters through which the water is drawn off and from which it flows to a final settling box to collect any slime carried in suspension. It is then delivered to two sump tanks to be pumped back to the mill and used over again.

The thickened and dewatered pulp from the settling tanks is drawn off from the bottom discharge through a pipe line connected to the suction of a centrifugal pump. This pipe line is arranged so that the contents of any tank can be drawn off. A cyanide solution pipe is connected to each tank to introduce solution if desired. The pulp is discharged by the pump into the agitator tanks, which are of the tall, cylindrical, conical-bottom type of 100 tons capacity each, and designed for rapid extraction of gold and silver by means of air agitation in a weak solution containing a small percentage of cyanide.

It was assumed that silver was the predominating metal in the ore that required about 36 hours to be brought into solution. After the required agitation the pulp is drawn from the agitator tanks by two centrifugal pumps and delivered into the pulp storage tanks, where it is kept in gentle agitation and prevented from settling by a stirring gear. From the storage tanks the slime is drawn into the filter tanks as required.

For removing the solution from the pulp the vacuum filter system is used. A charge of pulp is delivered to the filter box, and, after removing the solution by a vacuum applied to the filter leaves and following it up with the necessary washings,

it is finally discharged through the bottom of the tanks and is sluiced out. The solution is collected in a small storage tank and from there is pumped through a clarifying filter press into any one of the six precipitation tanks.

By means of zinc dust introduced in the form of an emulsion and with agitation by compressed air, precipitation is effected. The contents of the precipitation tanks are pumped to the refining plant and the precipitates are collected in the filter presses through which the material passes. The solution is delivered to the storage tanks for restandardizing before using again. The precipitates are dried and shipped to the refineries for reduction to bullion. The loss of cyanide of potassium is about $4\frac{1}{2}$ pounds per ton of ore treated.

All elevators and pumps for handling water solution and slime for such a plant as described should be installed in duplicate to insure against stopping the plant in case of a break-down.

In a cyanide plant for treating gold ores the number of tanks and agitators will be reduced according to the time required for bringing the gold into solution, and loss of cyanide of potassium in pounds per ton of ore treated will be proportionally lower.

The cyanide process is developing rapidly and in some of the most modern cyanide mills, both amalgamation and concentration are eliminated, except in cases where the ore contains material that is detrimental to the action of cyanide, or where the ore contains sufficient lead to warrant the additional expense of concentration. The general tendency of up-to-date metallurgists is to simplify the mill as much as possible.

Mention should be made of the modern practice of crushing in a weak cyanide solution and not using water at all. This practice is adopted even where concentration is necessary. The reason for crushing and concentrating in cyanide solution is that it prevents dilution of the cyanide solution by the water in the tailings where water is used for crushing, and also hastens the process by immediately acting on the gold or silver.

來 來

Converting Basic Slag Into Fertilizer

According to a United States Consular Report a new industry for Sydney, Nova Scotia, is a plant for converting basic slag, at present a waste product of the local steel works, into a fertilizer. The Dominion Iron and Steel Co. has con-

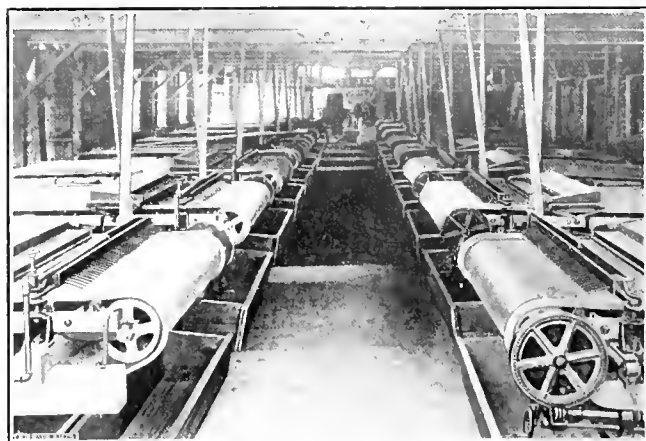

FIG. 3. VANNER ROOM

tracted with a company providing for the use of the steel-slag waste from their Bessemer plant as material for the manufacture of a fertilizer. At present, the slag from the steel works, amounting to about 30,000 tons per year, is dumped into a creek.

Driving the Loetschberg Tunnel

Methods and Machinery by Which Rapid Work Has Been Accomplished Under Difficult Circumstances

The following is an abstract from an article entitled "Tunnel Driving in the Alps," by W. L. Saunders, which was published in the Transactions of American Institute of Mining Engineers.

The Loetschberg tunnel, driven through the Bernese Alps, in Switzerland, is the last link of a railroad system connecting the city of Berne directly with the village of Brigue, which is situated at the north portal of the Simplon tunnel. With its completion, and the lately finished 12,000-foot Weisenstein railroad tunnel located about 30 miles north of Berne, it forms the shortest route between London, Paris, Brussels, or Hamburg, and Genoa, via Berne, Thun, Brigue, and Milan.

The question of connecting the Bernese Oberland with the Rhone valley had its origin as far back as the year 1866, and the present location of the tunnel was proposed in 1899.

Estimates were prepared, and the cost of the new proposed tunnel was calculated to be:

Tunnel excavation and lining.....	\$ 8,660,000
Tracks, installations, etc.....	1,400,000
Total	\$10,060,000

or a total cost of \$211 per linear foot.

The new road begins at Frutigen, in the Bernese Oberland, about 32.5 miles from the north portal; 50.5 per cent. of this length is on horizontal curves, and 90 per cent. is on grade. There are 12 tunnels, aggregating 16,000 feet, one of which is a spiral tunnel 5,460 feet long, with a 985-foot radius. The maximum grade is 2.7 per cent., and the difference in elevation between Frutigen and the north portal of the Loetschberg tunnel is 1,370 feet.

The main tunnel is 47,678 feet long, and was first planned to be on a tangent. After the cave-in of July 23, 1908, it was found necessary to insert a curve of 3,600 foot radius in the tunnel in order to drive through solid rock. The elevation of the north portal is 3,940 feet; of the south portal is 4,000 feet., and the maximum elevation of the tunnel is 11,081 feet above sea level. The maximum grade in the tunnel is 7 per cent. The distance from the south portal to the end of the line, at Brigue, is 15.75 miles. Of this length 28 per cent., or 23,200 feet, consists of 21 tunnels, the longest being 4,450 feet. Of this stretch 54 per cent. is on curves, and 90 per cent. on

have been calcareous for a distance of about 13,100 feet; while on the south side, crystalline schist has been found on about 13,000 feet, and granite, forming the central part of the mountain has been penetrated by both headings.

On July 24, 1908, when the main heading had reached a point 16 miles from the portal, it struck a cleft filled with sand, gravel, and water. There was a sudden and violent inburst of these materials, which in a few moments filled up the tunnel for a length of 5,900 feet, burying 25 workmen and

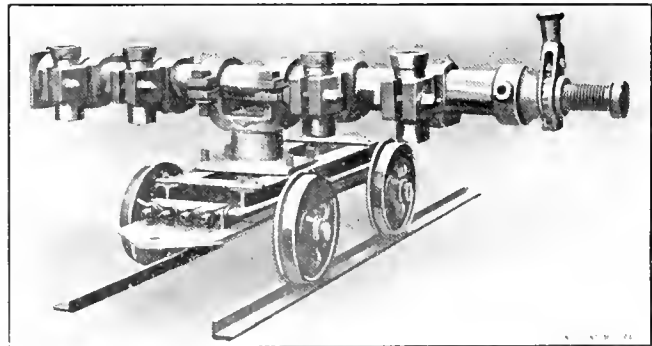

FIG. 2. CARRIAGE FOR FOUR DRILLS

all the drills and other installations beyond hope of recovery. It is estimated that about 8,000 cubic yards of sand and gravel entered the tunnel.

To avoid any further irruption of the materials, the tunnel was walled up by a 33-foot wall at a point 4,675 feet from the portal.

A commission of engineers was convened to decide upon a course to be adopted. Three methods were considered: (1) To force the tunnel through on the original line; this was considered impracticable, due to the great pressure from the 590-foot depth of water, sand, and gravel, over the tunnel. (2) To use the freezing process; this also was considered impracticable. (3) To deviate the line and cross the Gastern valley further up stream. The last plan was adopted. The new line leaves the original location at a point .75 mile from the north portal. No further serious difficulty was experienced in tunneling through the diversion.

Driving of the headings was begun on October 1, 1906, for a single-track tunnel, and continued until October 1, 1907, when it was decided to drive a double-track tunnel; 86 per cent. of the tunnel had been driven by October 31, 1910, and it is expected that, unless unforeseen delays or accidents occur, the headings will meet in 1911. On October 31, 1910, the 4,000 feet of heading, which had been abandoned after the cave-in of 1908, had been regained.

The power plant for the south heading, situated at Goppenstein, is driven by electric power. The current is brought at 15,000 volts, and stepped down to 500 volts for power purposes.

Compressed air for the drills is furnished by three two-stage Ingersoll-Rand compressors, each having a capacity of 1,950 cubic feet of free air per minute, and a compression of 145 pounds per square inch. They are driven by 400-horsepower electric motors. Compressed air for the locomotives is furnished by two four-stage Ingersoll-Rand compressors, having a capacity of 460 cubic feet of free air per minute, and a compression of 1,760 pounds per square inch. They are driven by 250-horsepower electric motors.

The power plant for the north heading is situated in Kanderteg. Electric power, used throughout the works, is brought from Spiez at 15,000 volts, and stepped down to 500 volts for power purposes in the tunnel as well as in the shops.

Compressed air for the drills is furnished by two two-stage Meyer air compressors, each having a capacity of 1,770 cubic feet of free air per minute, and a pressure of 117 pounds per

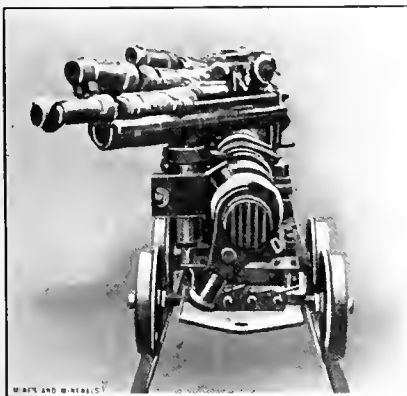

FIG. 1. CARRIAGE WITH DRILLS

grade. The difference in elevation between the south portal and Brigue is 1,110 feet, and the maximum grade is 2.7 per cent.

Summarizing, the total length of the road is 45.8 miles, of which 36 per cent., or 86,900 feet, is tunnels. Let it be added that, for construction purposes, a narrow-gauge railway had first to be built to reach both portals. On the south side of the tunnel the construction railway necessitated 38 tunnels, aggregating 18,000 feet. Of the 38 tunnels, 11 only will be part of the permanent road.

Beginning at the north portal, the materials penetrated

square inch. They are belt-driven by 450-horsepower electric motors.

Compressed air for the locomotives is furnished by two five-stage Meyer high-pressure compressors, with a capacity of 565 cubic feet of free air per minute, and a pressure of 1,760 pound per square inch. They are belt driven by a 250-horsepower electric motor.

All trains in the tunnel are operated on a regular time schedule, changed from time to time according to the progress of driving.

Steam locomotives are used outside, while compressed-air locomotives are run inside of the tunnel. A few mules are still in use in the south bottom heading.

Four types of cars are used for the service inside and outside of the tunnel: (1) Passenger cars having a capacity of 24 men each, and run only when shifts are leaving or entering the tunnel. (2) Cars having a capacity of 35 cubic feet, used for mucking. (3) Cars of 70-cubic-foot capacity, used chiefly for

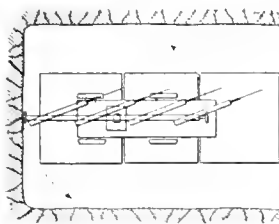

FIG. 3

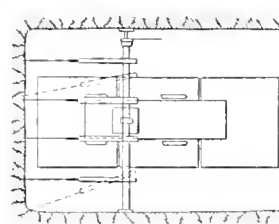

FIG. 5

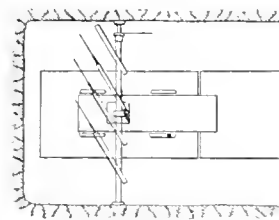

FIG. 4

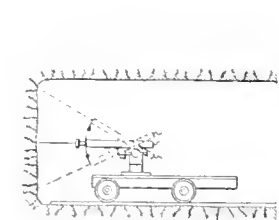

FIG. 6

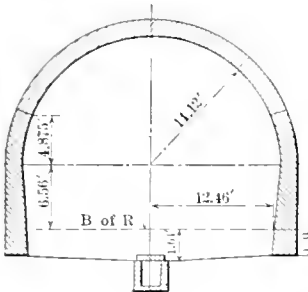
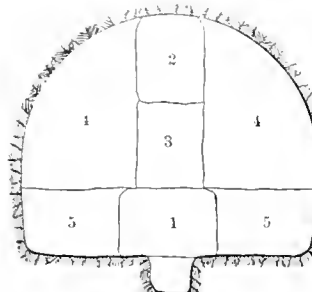

FIG. 7



transporting masonry materials. (4) Flat cars, used for timber, rails, etc.

The gauge for all tracks laid in the tunnel is 30 inches; the rails, of from 30 to 40 pounds per yard, being laid on wooden stringers, except in the last 100 feet of the bottom heading, where portable rails with pressed-steel tires are used. Trains are run in the tunnel at a speed of from 8 to 10 miles per hour.

Electric light is used only in that part of the tunnel already lined with masonry and partly completed. Portable acetylene lamps are used throughout the tunnel with a few exceptions.

Drainage on the north side of the tunnel is provided by means of a ditch 2 feet 8 inches wide, and 2 feet deep, placed between the two tracks. It has the same slope as the tunnel. The flow of all springs encountered on this side of the tunnel amounts to about 105 gallons per second, most of the water coming from that part of the tunnel where the cave-in occurred in 1908. The flow on the south side of the tunnel amounting to only 20 gallons per second, the section of the drainage ditch is but half the size of the one on the north.

The records made in driving the headings are due to the excellent organization, and to the methods of setting up and taking down the drills.

Fig. 1 shows a carriage with drills mounted in position to be taken from the heading after a blast, and Fig. 2, the carriage carrying four drills. In this type the beam and counterweight are omitted, the bar, on which 4, 5, or 6 drills are mounted, being placed directly on the truck. The width of the tunnel in which these cars can operate varies from 6 to 13 feet.

A drill carriage of simple but efficient design was devised by the contractors. Each carriage carries four or five drills, Fig. 3 shows the carriage, together with the drilling machines, when brought forward just after mucking in the heading. Fig. 4 shows the horizontal shaft swung into position ready for being jacked, and the drills ready to be swung into the position shown in Fig. 5. It can be seen from Fig. 5 that the drills can be swung through an arc of a circle or moved sideways, while in Fig. 6 the different positions which the drills can be given by being swung in a vertical plane are shown.

The time required to change the machine from the position shown in Fig. 3 to that shown in Fig. 5 and to commence drilling is usually from 6 to 8 minutes. This shows the superiority of carrying the drills for such work over any other method used up to the present time.

Three kinds of explosives are used. Dynamite, with about 85 per cent. nitroglycerine, is mostly used in the headings. Westphalite and cheddite, being more safely handled, are used for enlarging and for small blasts.

Great stress is laid on the fact that a high-grade explosive breaks the rock into small pieces, not larger than an orange, which enables mucking to be done with shovels.

Firing is done with ordinary fuses. The dynamite cartridges are wrapped with red paper in order to be easily detected in case of a misfire; and dynamite carriers and handlers are provided with red lanterns.

Italian labor is used throughout the works with the exception of some Macedonians lately imported. Mostly Italians from the northern provinces of Italy are employed.

A bonus system of payment is used throughout the different kinds of operations. The following wages are paid:

Drill foreman, \$2.60; drill runners, \$1.70; muckers, \$1.30; nippers, \$1; tracklayers, 95 cents; masons, \$1.40.

There are three 8-hour shifts per day.

As shown on Fig. 7, the width of the finished section is 28 feet at the arch springing and 25 feet at the base of the rail. The arch is semicircular, the crown being 20.7 feet above the base of rail.

The sequence of excavation is illustrated by Figs. 7 and 8. A bottom heading 6.5 ft. \times 10 ft. is first driven several hundred feet in advance of the enlargement. Upraises are then driven from 500 to 600 feet apart, and a top heading started back and forth. The top heading is then enlarged as shown by the sections in Fig. 8.

In the bottom heading the mining operations proceed as follows: The drill carriage is run forward from its siding close to the face of the heading, passing over 5' \times 5' \times $\frac{3}{4}$ " steel plates laid on the floor of the heading for a length of about 30 feet. Each plate is provided with 1-inch holes at the corners for ease in handling with a pick.

The water and air pipes laid on one side of the heading to about 40 feet from its face are connected with the drill carriage, and the drilling begins with the top holes. Water sprinkling is frequently done, especially in starting the holes, in order to lay the dust.

Without interfering with drilling, mucking is going on just behind the drill carriage, and the loaded muck cars are run back to a siding, where trains of from 20 to 30 cars are formed and hauled out by air locomotives.

Drilling being completed in the heading, the drill carriage is run back to its siding, and the steel plates laid on the floor

are covered with a layer of muck about 4 inches thick to prevent deterioration.

The drill holes are then loaded and carefully tamped, and the last man to leave the heading, after firing the fuses, opens the air-pipe valve, the escaping air thus creating a cushion of fresh air from the face of the heading back to a certain distance, so that after blasting, the muckers are able to go to work without delay.

A high-grade explosive only is used in the heading, which breaks the rock in small pieces and renders mucking with

shovels for any dynamite cartridges which might not have exploded. If the eight men fill the car, as shown at M, which takes 3 minutes, then they rest for 3 minutes, while the second gang of four men fill the second car, etc.

Drilling is started not more than 5 minutes after the removal of the last carload. This result, which at first sight seems impossible, is only obtained by absolute discipline.

The man who knows that his only work at this moment is to connect the air main to the drill carriage does not do anything else; the men whose duty it is to screw the carriage tightly to the wall immediately jump to the right place.

The system has been adopted for a 7-foot wide gallery in the production of 1910; that is, the gallery is 6 feet high by 12 feet wide.

The rate of drilling is 15 to 16 holes in from 11 to 13 hours.

Drilling in the top heading is accomplished by means of two or three drills attached to trucks or to a horizontal bar. These hammer and drills are used generally for the enlargement.

Mucking operations in the top heading are very simple, since all blasted material is dumped directly through the supports into cars running on a siding in the bottom heading.

The operations of blasting, mucking, mucking, and hauling are performed without interruption and without interference with each

other, and a special force of engineers is required in order to obtain such a result.

All employees and workmen are insured against accident or death, by the contracting company, and great care is therefore exercised in handling explosives and in operating the trains. Data pertaining to the driving of the bottom heading are given in Tables 1 and 2, and the rate of progress in the bottom heading is given in Table 3.

Ventilation in the tunnel is obtained from two fans 11.5 feet in diameter, having a capacity of 50,000 cubic feet of air per minute at 5-ounce pressure. Each fan is belt driven by a 175-horsepower electric motor housed in a building at each portal, forming part of the permanent ventilation system.

Air is taken in that part of the tunnel already completed through a canal of 65 square feet area, made of hollow tiles,

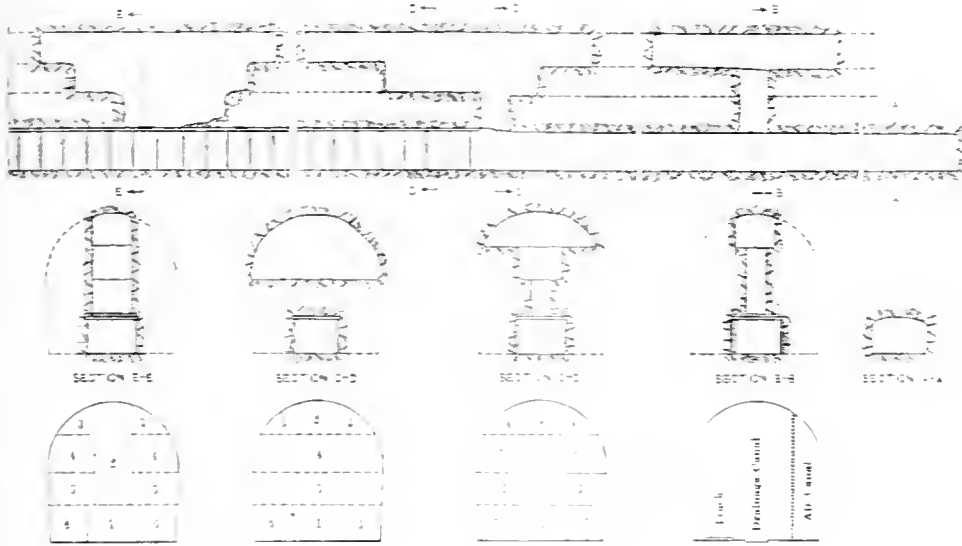

showels easy. The drill holes, having an average length of about 4 feet, are started with a 3-inch bit and finished with a 2-inch bit. On account of giving better results, time is lost with fuses, about 4 feet long, the center holes are drilled first.

Mucking operations proceed as follows: Two empty cars are run to the heading, the first one being immediately loaded by two or three men shoveling without interruption until the car is fully loaded. This operation is performed in 3 or 4 minutes, which means that 1 cubic yard is loaded in from 2.5 to 3 minutes.

Owing to the manner of drilling and blasting and to the shallow holes, the muck, instead of piling up in front of the face of the heading, is thrown back, and forms a layer over the face, which enables the track to be cleared rapidly.

At Loetschberg a cubic-meter car 35.5 cubic feet is filled in 5 minutes, and it takes only 1 minute to get this car away and bring an empty car to the heading. In order to do this, small entries or chambers are excavated at intervals in the lateral wall of the main heading, which enables an empty car to be thrown from the track on the side, thus clearing the track and allowing the filled car to pass, whereupon the empty car is turned up on its wheels and rolled into the heading. An illustration of an improvised siding in a narrow heading, by means of which one car may pass another, is shown in Fig. 9, the operation being as follows:

When the car, A, is filled, it is taken away on the track, B, and immediately after it has passed the point, C, the empty car, D, which had been turned on its side, is righted on the track, and brought to the advancement in the space of 1 minute. As soon as the car, D, has been brought to the advancement, another empty car, E, is brought to the same point, C, turned on its side, until car, D, is filled and taken away. In one instance, 14 carloads, each of 1 cubic meter volume, were taken away in 1.5 hours, which cleared the heading completely and allowed the drill wagon to be brought in. Eight men remove the debris, two men go to the face F, and search the

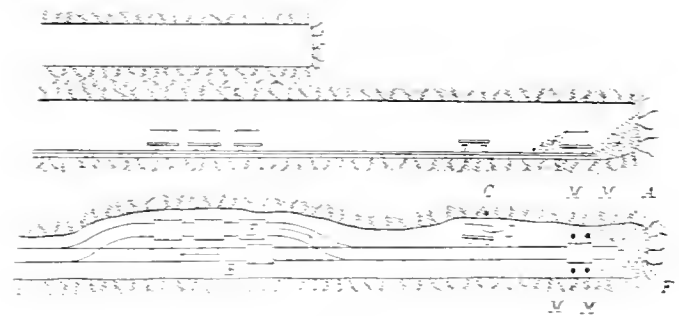

FIG. 9

shown in Fig. 8, then through steel pipes to electric-driven blowers running in series, and having a capacity of 6,800 cubic feet of air per minute at 14-ounce pressure. These two blowers are mounted on carriages, and are moved along as the work advances.

Openings are provided at intervals in the above-described air canal so as to allow part of the air to escape in the tunnel.

TABLE 1. DATA OF DRIVING 430 FEET OF BOTTOM HEADING (NORTH SIDE)

Number of rounds.....	5
Number of linear feet driven per round.....	112
Number of hours per round for drilling.....	3.84
Number of hours per round for blasting and mucking.....	1.39
Number of rounds per 24 hours.....	4.58
Total length of bore holes per round, feet.....	5
Number of holes per round.....	55.40
Average depth of bore holes, feet.....	12
Length of holes per cubic yard, feet.....	4.43
Dynamite used per cubic yard, pounds.....	6.25
Number of steel bits used per cubic yard.....	5.80
	1.45

TABLE 2. DATA OF DRIVING 1,751 FEET OF BOTTOM HEADING (SOUTH SIDE)

Number of rounds.....	510
Number of linear feet driven per round.....	3.41
Number of hours per round for drilling.....	1.25
Number of hours per round for blasting and mucking.....	2.91
Number of rounds per 24 hours.....	5
Number of bore holes per round.....	11.70
Total length of holes per round, feet.....	40.70
Average length of holes.....	3.54
Length of holes per cubic yard, feet.....	5
Dynamite per cubic yards, pounds.....	5.95
Number of steel bits per cubic yard.....	2.85

TABLE 3. RATE OF PROGRESS PER MONTH IN BOTTOM HEADING JUNE, JULY, AUGUST, AND SEPTEMBER, 1909

	North Side *	South Side †
Progress, feet.....	959.30	526.60
Number of drills.....	4	5
Average daily progress.....	34.30	17.50
Temp. rock F. degrees.....	59.75	83.77

* Material in north heading, limestone.

† Material in south heading, crystalline schist.

In comparing conditions on the north and south ends of the Loetschberg tunnel, it is well to bear in mind that at the south end the rock is generally harder and the temperature higher. At the north end the temperature varies from 75° to 80° F., while at the south end it has reached a maximum of 110° F. It is also claimed that a remarkable organization of the working force exists on the north end. The settlement at south end was built by the Loetschberg company. The winter there is extremely severe and dangerous. Three years ago, by an avalanche, seven men were killed, among them an American engineer named Merwarth, who was at the time installing the compressed-air machinery. Conditions of this kind do not favor the contractor in getting the best kind of labor. Kandersteg, at the north end, is practically a summer-and-winter resort, full of good hotels, easy to reach, and a more favorable labor market.

At one time, when the north heading was making a daily progress in excess of the south heading, the contractors sent some of the drills from the north heading over to the south, thinking that perhaps the difference in progress was due to the drill, but the results were not changed. It seems plain that were it a question of machinery only, the machinery making the greater progress would be used throughout, but the difference appears to be one of natural conditions and of organization.

采 采

Ore Mining Notes

The Hartford Mine Fire.—In the Hartford iron mine, near Negaunee, Mich., seven men were smothered by the timbering catching fire. Taken in the aggregate, the loss of life in metal mines due to mine fires will approach closely that in coal mines.

Metal Mine Fire.—Rock high in sulphur is on fire in the Youngs mine of the Breitung estate on the Menominee Range. The company working this property brought a winze through to the surface and capped it with a smokestack, up which the fumes from the burning mass are being safely conveyed from the mine.

Careless Blasting.—An explosion in the Czar shaft of the Copper Queen mine, Bisbee, Ariz., took place some time ago, in which one man was killed and seven others were injured. The men were going down into the mine on a cage when the blast was set off. The cage was down about 250 feet when the

explosion occurred, and every man of the eight on the cage was injured, but not seriously, except the one that was killed. It is not absolutely known whether the explosion hurled a boulder into the passing cage, or whether the shock of the explosion jarred a section of rock from the side of the shaft.

Unwatering Giroux Mines.—When the pumps were started on the 1,200-foot level of the Giroux Consolidated Mines, Kimberley, Nev., the water in the Alpha workings subsided at the rate of 3 feet a day. It is presumed that the water zone will be passed through at this depth, and miners are now engaged in finishing the station at the bottom of the shaft where a permanent pumping plant will be installed.

Canadian Blast Furnace.—The largest blast furnace in Canada has been lighted with appropriate ceremonies by Miss Ruth McDonald, in connection with the Lake Superior Corporation. It has a capacity of 500 tons, and there is work awaiting it sufficient to keep it going 5 years.

Cochrane, Ontario, Chimney Gold.—According to the Cobalt Nugget, Cochrane, Ontario, has the gold fever. A few days ago a plumber was taking down a chimney of one of the houses burned in the fire at Cochrane. He found a speck of gleaming metal in the cement, and with the gold fever in the air went to an old miner with it. It is alleged that the latter said it was gold and then the excitement began. The rush was to discover where the sand came from that was used in the chimney. That discovered, the plumber and his friends got a miner's license from Matheson and hiked out to stake out the sand pit. Others on the suspicion that the plumber might have made a mistake in the location of his sand staked out the only other sand deposit in the neighborhood. If this excitement continues the Gold Dust Twins will be staked out.

Cananea Consolidated Copper Co.—The new construction work at the Cananea Consolidated Copper Co.'s plant, at Cananea, Mex., is completed, with the exception of the dust chamber for the converters. Six new McDougal furnaces have been installed, bringing the total to 10. The spreading bed for handling the calcined ore from the roasters is in operation, and the ore dryers are installed. Since the 1st of April the Miami concentrates have been sent to Cananea from the Globe, Ariz., district, at the rate of about 50 tons daily.

A 10,000-Dollar Grub Stake.—In the mining industry of Colorado several thousand dollars have been subscribed to a fund to grub stake prospectors. The word has gone forth that Colorado needs another camp like Cripple Creek or Leadville, and it is presumed that its discovery will be heralded to the world before the snow flies.

Reopening the Henrietta Mine.—The Greene-Cananea Copper Co. has reopened the Henrietta mine after a shut-down of about 10 months. An electric hoist has been installed and the force of men increased considerably over the number at first placed at work. It is reported that the Puertocitos mine will be reopened eventually. The first trains from Naco brought a large amount of concentrates which were waiting the resumption of railroad operations. They were shipped by the Miami company. The first day the road was opened three freight trains were run into Cananea, carrying supplies and concentrates. The first trains out of Cananea contained many cars of bullion that had accumulated during the tie-up.

Alaskan Gold.—When the steamer Schwatka sailed for Fort Gibbon a few days ago from Fairbanks, she carried more than a ton of gold bricks. The shipment is valued at \$500,000. Another shipment, the value of which was not made public, was made by the American Bank. The clean-up is progressing on all creeks and gold-dust shipments are coming into town daily from the mines. So far there has been plenty of water for washing.

A New Nye County, Nev., Silver Mine.—William Lloyd and E. A. Hodges have located ground along a ledge of rocks about 125 miles southwest of Pioche, and about 25 miles north of the San Pedros main line. The white men were guided to

the spot by two Indians. The rock forwarded to Salt Lake City is tinted delicately with yellow and green and is fairly loaded with silver and lead.

The Pittsburg Mine of California.—The Pittsburg mine, which is located near Nevada City, Nevada County, Cal., has been developed to the 1,300-foot level, where a good body of ore has been found. The 20-stamp mill of the property is running at full capacity on an excellent quality of quartz.

The Black Oak Mine—In the Black Oak mine, near Soulsbyville, Tuolumne County, Cal., the vein which was lost several months ago has been recovered. It was found on the 15th level with about 5 feet of ore in evidence. The vein was lost about 2 years ago after yielding more than \$1,000,000 of gold, and its recovery beyond the fault is expected to add new life to the entire district, as it demonstrates the persistent nature of the veins in no uncertain manner. The Black Oak property is equipped with a 40-stamp mill, canvas concentrator, and cyanide plant. R. C. Knox is manager.

The Montana Smelters.—The ore output of the original group of the Anaconda properties in Montana is sent to the Washoe smelter at Anaconda, and the ore taken from the mines formerly owned by the Boston & Montana Co. is nearly all sent to the smelter at Great Falls, Mont. Under normal conditions about 10,000 tons of ore are hoisted to the surface and sent to the Washoe smelter in steel cars weighing 18 tons each and carrying about 50 tons of ore. Taking into consideration the custom ore and the supplies other than coal and coke, a combined tonnage of 14,000 tons is brought to the Anaconda smelter every day in the year. To treat the 10,000 tons of ore from the mines, 2,000 tons of crushed lime rock and about 1,000 tons of the coal and coke are required daily.

Green River, Utah, Oil Field.—According to advices, oil in large quantities has been found in the Cook-Lebi well near Green River, Utah. The oil is found in the second sand, or less than 500 feet in depth, and it is estimated that from 125 to 200 barrels a day are flowing. The oil is said to analyze 60 per cent. gasoline and 35 per cent. gravity.

Steamboat Camp, British Columbia.—It is reported that a discovery of a 75-foot vein of copper ore has been made in the new Steamboat Camp in British Columbia. The value of the ore has not been made public.

Progress in the Ketchikan District, Alaska.—The Alaska Industrial Co.'s property near Sulzer, on the west coast of Prince of Wales Island, is being steadily developed. Shipments of ore have been made monthly since 1906, the output for 1910 being over 20,000 tons of a good grade of copper (chalcopyrite) carrying from \$1.50 to \$2 in gold per ton. Under the management of Chas. A. Sulzer, the expense of operating, as well as that of building a tram road, of installing machinery, and of acquiring some 100 claims, has been largely paid for from the proceeds of the ore. The greater part of the force of 50 men are now working in ore of which an ample supply seems assured, a diamond-drill hole sunk last summer still being in mineral at a depth of 123 feet.

Tungsten Mining.—The principal tungsten properties in the Randsburg, Kern County, Cal., district, with the exception of the Atolis Mining Co. properties, are owned by the following individuals: J. S. Deacon, W. A. Wiskard, B. M. Atkinson, F. W. Atkinson, and Samuel H. Dolbear. The deposits are very irregular and cannot be developed by ordinary working methods without the expenditure of considerable capital. It is doubtful if even the Atolis company has at any time had a year's reserve of ore developed.

Snake Bite.—It will be of interest to total abstainers to learn that whiskey as an antidote to snake bite is tabooed. For hydrophobia, skunk bite, rattlesnake or copperhead bite, for scorpion and tarantula stings, use permanganate of potassium, $KMnO_4$, in solution. Tie a tourniquet above the wound, then cut it deep with a knife, and if there is no one to suck the wound previously, apply the solution or rub in the permanganate

in crystal form the same as a barber applies alum to a cut. Permanganate of potassium dissolves in 20 parts of water, forming a purple-red solution, which turns yellowish-green when brought in contact with a substance having affinity for oxygen. It is a caustic and an oxidizer.

The 70-ton smelter of the Clara Consolidated Gold and Copper Mining Co., at Swansea, Ariz., was blown in on June 19. The company is still doing considerable construction work in the way of improving facilities for handling and treating ores. A spur track from the Arizona and Swansea Railroad is being continued by means of a switchback to a point above the reduction works, which, when completed, will allow customs ores, coke, and fuel to be handled by gravity direct to the points of consumption at a minimum cost. A No. 11 Roots blower is being installed which will give additional blast to the furnace and considerably increase its capacity. A 44-foot structural steel extension to the converter building has recently been completed. The sampling plant for handling customs ores has been finished and is now in operation. This will give the small producers of that section an opportunity of disposing of their ores to advantage and will, no doubt, greatly increase mining activity in the vicinity. Development of ore bodies in the company's mines at Swansea is being pushed, particularly on the 400- and 500-foot levels. Considerable exploration work with churn drills is also being conducted with gratifying results.

Electric Power Plant of the Santa Rosa Mining Co.—The Santa Rosa Mining Co., located in the State of Zacatecas, Mex., near Concepcion del Oro, is erecting most of the machinery that will enter into the equipment of its mills. Electric power is supplied to the property from a gas-producer plant. The gas engine will be connected by a belt to a 150-kilowatt Westinghouse alternating-current generator. Switchboards, transformers, etc., and 20 motors have been installed. The tube mill is driven by a 60-horsepower motor; there are 7 motor-driven direct-connected pumps for supplying water to the cyanide plant, and nine other motors located at various places around the plant. A transmission line about 2 miles long supplies the current to three motor-driven pumps, which control the water supply.

采 采

Chute Hook at Radiant Mine

We are indebted to Mr. J. Q. McNatt, mining engineer, of Florence, Colo., for the sketch of a hook used to clean the mine-run screens at the Radiant mine of the Victor American Fuel Co., near that city. It will be noted that the rake shape of the points makes this more effective in removing pieces of coal

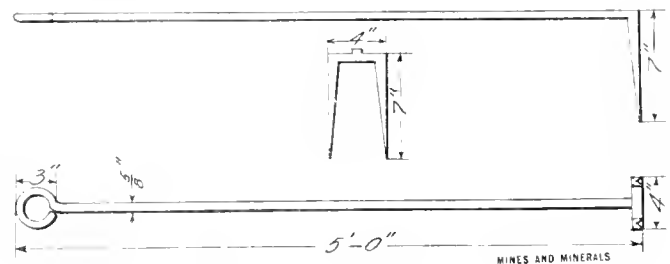

PLAN AND SECTION OF CHUTE HOOK

wedged between the bars of a screen than the single point of a pick. This hook is particularly useful to the car trimmer as the double points enable him to easily draw forward a lump of coal which may need to be broken to remove a layer of slate or bone. It would seem, for use by the car trimmer, that the handle had better be made elliptical in shape, similar to that employed on coke scrapers, than circular as in the sketch. The points of the hook being sharpened, the use of a pick is dispensed with.

The Cranberry Iron Ore Mine

Large Deposit of High-Grade Magnetite. Methods of Mining and Electric Concentrating

By J. M. Cameron, M. E.*

In 1887, W. C. Kerr and G. B. Hanna of the Geological Survey of North Carolina, wrote a book entitled "The Ores of North Carolina." In this a short description of the Cranberry ore bank will be found. In the May, 1911, issue of *Mine and Quarry* there is a descriptive article on the Cranberry mine by B. C. Hodgson, from which much of this article has been abstracted.

The Cranberry iron ore deposit is formed by an aggregation of magnetite crystals cemented together so as to form an almost pure mineral mass. Magnetite, Fe_3O_4 , when chemically pure, contains 72.4 per cent. iron and 27.6 per cent. oxygen; as found in magnetic form, however, the iron analysis is not likely to exceed 70 per cent. Of the two analyses given, No. 1 was made by the late Professor Genth, of Philadelphia, and No. 2 by the late Professor Chandler, of New York City. From the analyses furnished, the writer is inclined to the belief that they were made from picked samples and not run-of-mine or shipping ore.

Cranberry ore bank, which is on the western slope of Iron Mountain, in the northeastern part of Mitchell County, N. C., receives its name from Cranberry Creek, which flows at the foot of the steep hills on which it outcrops. It is owned by the Cranberry Iron and Coal Co., who mine and ship it to their furnaces at Johnson City, which is 34 miles distant.

The ore deposit is in the form of a large lense whose length and depth are not fully known. The gangue minerals are pyroxene, epidote, quartz, feldspar, and garnet, with occasionally other minerals of a common kind. It is now the generally accepted belief that the magnetite deposits of the Appalachian Mountains crystallized from the magmas of which they formed a part. The isometric crystals, when small, formed a hard compact mass, but when large the mass had less cohesion, and on account of the diamond-shaped crystal faces it presents, it is locally termed "rattlesnake ore." The magnetite is asso-

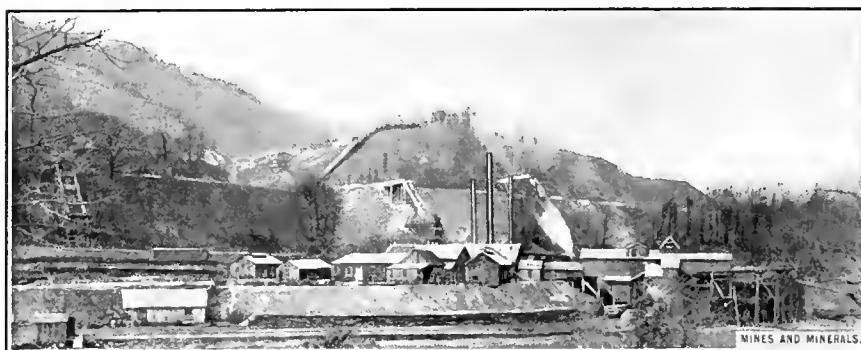

FIG. 1. CRANBERRY IRON MINE

ANALYSES OF CRANBERRY ORES

	No. 1	No. 2
Magnetite Fe_3O_4	94.37	91.83
Magnesia MgO36	.23
Alumina Al_2O_342	1.03
Lime CaO43	1.06
Manganese oxide MnO_226	.32
Water.....		1.15
Silica SiO_2	4.16	4.02
Sulphur S.....		.25
Phosphoric acid P_2O_5		

ciated with epidote and feldspar, which form horses in the deposit and decrease its purity; usually, however, it is in lenticular masses whose greatest lengths are along the strike, and these are the chief sources of ore. The thickness of the ore lenses varies from a few inches to 70 feet.

*Johnson City, Tenn.

The country rock is gneiss in contact with syenite; the ore zone, however, is confined within the gneiss. The normal strike of ore beds in the Appalachian Mountains is northeast and southwest, and as the Cranberry bed strikes northwest and southeast it would indicate that it had been subjected to faulting, and this probably accounts for the deposit being cut out by rock in a southeasterly and narrowed in a northwesterly direction. A general idea of conditions prevailing at the Cranberry mine can be had from Fig. 1. At the outcrops on the top of the hill the deposit is approximately 400 feet wide between the foot-wall and hanging wall, and has an average dip of 34 degrees. The top 80 feet of the deposit was worked as an open-cut mine until drift and stope mining was substituted to avoid handling horses of rock. In order to reach the ore at the level of the valley a tunnel was driven about 450 feet in length. On reaching the ore the drift was continued to the right in a northerly direction 350 feet to the foot-wall. The drift was made large, and from it stopes were worked up to the open cut above, thus allowing daylight to shine into the lower or main level. A good idea of the height of one of these stopes can be obtained from the pillars, shown in Fig. 2, and the hole in the upper right-hand corner through which daylight shines. On the main level there are several parallel tracks which serve the rooms on this level and the three slopes put down from this to a level below. Underhand stoping is practiced,

and as the rooms are formed care is taken to secure such shape to the roof that when once finished it will remain safe indefinitely. After each blast a force of men termed "scalers" work from the top of the stope, pull down or break if necessary any pieces of ore likely to come loose in time, and thus make the roof

safe. As the drills are always advancing the stope room, the roof is usually left in safe condition. Occasionally, however, in some part the roof of one of the large rooms will need attention, and it is reached then by specially constructed ladders, or other means are devised by the scalers.

The three slopes sunk from the main level to the lower level are inclined at 30 degrees and have a length of about 400 feet. From these slopes, levels are driven right and left on the strike of the ore at intervals, and after any one of the levels has been advanced a sufficient distance a room is turned and by underhand stoping driven to the level above. Between adjacent rooms a pillar of ore shaped like an hour glass, as in Fig. 2, is left standing to support the cover, and as that is not heavy, a small pillar of strong ore is sufficient.

The open-cut level shown in Fig. 3 is approximately 100 feet higher than the main level. In the face of ore left after open-cut work was abandoned, levels have been driven, as shown, and rooms opened as on the other levels. In Fig. 3 an opening resulting from working upwards from the main level is seen, and this is now used as a chute for ore from the upper to the main level. The floor of the open cut, which has been stated as having been 400 feet from foot-wall to hanging wall, is also shown. During the time open-cut mining was followed the ore was loaded into cars and dumped into the chute shown in Fig. 1, and thus lowered to the ore bins.

Entirely separate from and 200 feet above the floor of the open-cut mine is another outcrop of magnetite. This deposit is separated from the other by a horse of rock which does not

pass through, although it enters the ore, for which reason the upper deposit is presumed to be part of the lower. Three slopes having a pitch of 38 degrees have been sunk on the upper deposit to a depth of 150 feet, only one of them, No. 2, will be continued, the other having been sunk to quickly open working places. At present the ore is hauled up these slopes by separate



FIG. 2. PILLARS IN CRANBERRY MINE

hoisting engines in end-dump cars having a capacity of 3,000 pounds. The cars are then run to the gravity plane shown in Fig. 1, but better shown in Fig. 4, and lowered to the open-cut level. Here the ore is dumped into a chute 80 feet long through which it slides into bins on the main level. The inclined plane from the upper deposit to the open-cut level is 275 feet long and has a perpendicular height of 145 feet, or a ratio of $\frac{1}{1.89}$.

At the top level, which is almost to the outcrop, the ore is 20 feet thick, but at a depth of 400 feet measured along the dip the diamond drill core shows it attains a thickness of 70 feet. The main, or No. 2 slope, of the top or outcrop level is being sunk on the true dip of the ore, and another starting from the main, or tunnel, level in the northwest corner of the old mine, is being sunk in the ore, with a view of eventually intersecting the No. 2 slope when the latter has reached a length of 1,800 feet.

About 30 standard piston rock drills of $3\frac{1}{2}$ and $3\frac{3}{4}$ -inch cylinder diameter are employed for breaking ground. These drills are mounted on tripods, or mining columns, and are driven by compressed air at 90 pounds receiver pressure. The ample size of the pipe lines and their careful arrangement and maintenance render pressure losses very small. Air reheaters, burning coal, insure dry air at the drills, and further minimize transmission losses. Both the rock and the ore itself are very hard, rendering the drilling slow and throwing a heavy burden on the drills. In recent diamond-drill prospecting, the average progress was 10 feet per 10-hour shift, but for much of the work only 2 feet per shift could be drilled. This will give an idea of the severity of the drilling conditions.

Drill Maintenance.—The cost of drill maintenance resulting from this difficult ground induced the mine officials to conduct very thorough tests on different kinds of drills. This investigation resulted in the adoption of the Sullivan $3\frac{3}{4}$ -inch tappet valve drills, which gave the best results in drilling speed and in repair costs per foot. Since these drills were put in, nearly 2 years ago, there has been a noteworthy reduction in maintenance charges, and an increase in the amount of ground broken per drill. The average drilling speed in this mine is about 6 feet per hour, or 30 to 40 feet per 10-hour day, including setting up, tearing down, and moving the drills. The ore is removed in benches, from 15 to 70 feet high, and the average depth of holes drilled is 8 feet.

The writer, when general superintendent of the company, designed an automatic lubricator which is used on all the drills at this mine and has maintained their efficiency at a high level. The oil chamber is so arranged that the oil is under air pressure, the pressure above the surface of the oil being about 15 pounds in excess of that at the discharge opening. This results in injecting a small quantity of oil into the cylinder at every stroke, and thus keeps the drill properly and positively lubricated at all times.

Ventilation and Drainage.—No artificial ventilation is required. The mine makes but little water in any of its workings, and is kept dry by a pump of 200 gallons capacity, running less than half time. These conditions render labor conditions much more agreeable than usual in a mine of this size and character.

About 25 years ago there was a small charcoal iron furnace in operation at Cranberry. The ore for this furnace was taken almost entirely from the surface outcroppings. Only the choice lump ore was used. The ore at or near the surface, being "weathered," crumbled easily into small particles. Practically all of the fine ore was thrown out with the waste rock and clay. As this went on for a number of years, there accumulated thousands of tons of dump material containing large quantities of ore in fine particles. About a year ago an investigation was made of the quality of these old dumps, with the result that they are now being worked. About 150 tons of this old dump material is being sent daily direct to the furnace, and about 75 tons of it is sent daily to the concentrating plant, making a total of about 225 tons of ore per day taken out of the dumps that but a few years ago were considered as having no value. The ore taken from these dumps and sent direct to the furnace averages about 40 per cent. in iron, has practically no sulphur, and less than .01 of 1 per cent. phosphorus.

The ore is transferred from the mines to the concentrating plant in trips of five cars, each car carrying 3,000 pounds of crude ore. Cars, as they reach the first crusher, are run into a cylindrical cage that, rolling sideways on a track, turns the mine car bottom up, dumping the contents into the crusher hopper. The crusher is a No. 5 Gates gyratory and discharges directly into a $32' \times 16'$ revolving screen, in which the ore first passes over holes $1\frac{1}{2}$ inches in diameter; the coarse ore then passes over holes $3\frac{1}{2}$ inches in diameter; the $1\frac{1}{2}$ -inch size goes



FIG. 3. OPEN-CUT LEVEL

from the screen to the washers; the $3\frac{1}{2}$ -inch size goes from the screen to "cobbing magnets." From these magnets the heads go direct to the loading bin, and the tails go to a smaller crusher. A feature in use at the cobbing magnets is worthy of note: the speed of these magnets is such that dead stock is thrown off by centrifugal force, and many tons of rock are in this way disposed of that would otherwise have to pass through the

smaller crusher. After leaving the washers the material is screened into four sizes: first, that which will not pass through a 1½-inch hole; second, that which, having passed through a 1½-inch hole, will not pass through a ¾-inch hole; third, that which, having passed through a ¾-inch hole, will not pass through a ½-inch hole; and fourth, that which passes through the ½-inch hole. These several sizes are known, respectively, as "coarse concentrate," "fine concentrate," "¾-inch con-

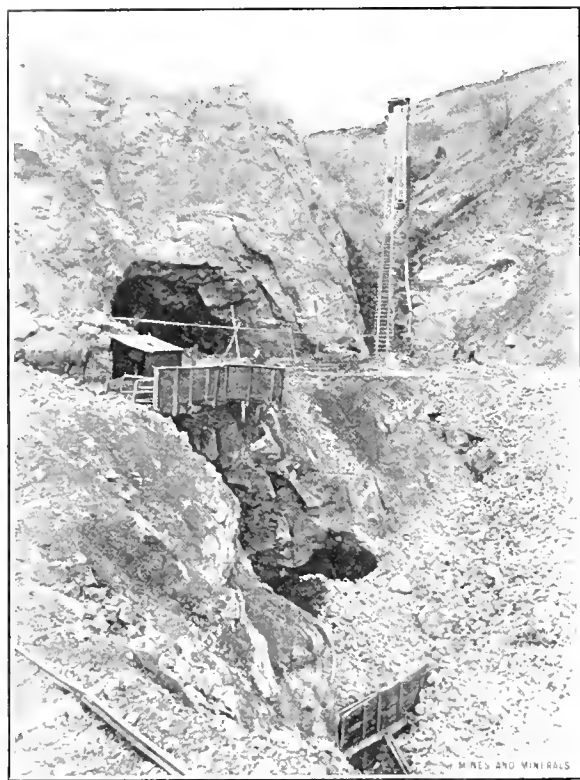

FIG. 4. INCLINE FROM UPPER DEPOSIT

centrate," and "dust concentrate." On leaving the screens, the coarse and fine concentrates pass over a series of revolving magnets, while the fine and dust concentrates are carried with a stream of water to magnets that revolve in a water-tight box and pick the ore up out of the water.

The magnets in use at the Cranberry concentrating plant are of the revolving cylindrical type. Each magnet has four poles, and carries about 10,000 feet of No. 11 copper wire. The voltage used is 125. Each magnet has attached a suitable rheostat, and the current varies from 4 to 10 amperes per magnet. In operation the current passing through the several magnets is closely watched and readings are taken twice in each 10 hours. When the crude ore coming from the mines carries an excess of phosphorus, the current on magnets is weakened, and there is a greater or less loss in consequence of the tails being richer. When the phosphorus in the crude ore is low, the strength of the magnets is increased; the tails are then proportionately leaner. While the Cranberry iron ore is noted for its small percentage of phosphorus, yet the uniformity and excellence of the product from these mines is largely due to the equipment at the concentrating plant and the care taken in the work of concentration.

The electromagnets in use at this plant are extremely simple, and when properly wired and insulated, run for years without any repairs whatever. The tailing leaving the final magnets averages about 16 per cent. iron. Of this about 8 per cent is insoluble. When it is remembered that there is no fine crushing of the ore, no rolls being used in this plant, it will be seen that the results obtained are exceptionally good.

The machinery of the concentrating plant is at such an elevation that the magnets discharge directly on to railroad cars beneath the plant. The cars for the "heads" being on one track and the cars for the "tails" being on another track. This arrangement is not entirely satisfactory, as there is difficulty at times, particularly in cold or stormy weather, in getting the cars to follow each other in such order as will not delay the work of the plant. On the whole, however, this concentrating plant gives good results, both as to the quality of product and economy in operation.

來 來

Diagonal-Plane Concentrating Table

A Description of a New Form of a Wet Reciprocating Concentrating Table

By S. Arthur Krom, Plainfield, N. J.*

Recent experiments indicate that the usual type of concentrating table is not only poorly adapted to produce the desired results, but also is based upon an incorrect principle, namely, the use of riffles to perform the work of stratifying the various minerals.

We have heard a great deal about riffles for concentrating tables; exhaustive experiments have been made to discover the proper form of riffle, or to prove the superiority of this or that form; disputes and patent litigation have arisen over the matter of riffles, and thus many have been led to believe that the riffle is the saving device upon which the process of concentration depends.

In the present paper it is proposed to show that the riffle is greatly overrated as to the part it performs in the concentration of minerals, and that, in the near future, it may possibly be eliminated entirely.

The experiments in question have shown that the troublesome riffle can be considered of secondary importance at the most, and should be so classed in the construction of a concentrating table built upon the right lines.

The action of any form of riffle on a concentrating table is such as to upset and retard the process of settling and stratifying the various minerals on the table deck.

From the deck of a riffle table no concentrates can be delivered until the deck is "bedded," that is, until a sufficient amount of material has been fed to and spread over a large

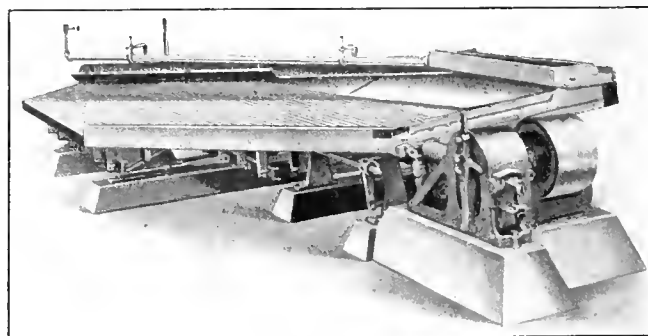

FIG. 1. DIAGONAL PLANE CONCENTRATING TABLE

portion of the deck, to form a substratum of the heavier minerals. This substratum must be maintained by the feed within narrow limits, and must be directly proportional to the rate of discharge from the table, in order that the bed shall not be lost. On the other hand, the riffles having a very small carrying capacity, considerable care is needed to prevent overfeeding; otherwise, the table will proceed, in mill parlance,

*Wilkes-Barre Meeting, A. I. M. E., June, 1911.

to rob itself. As soon as the space between the riffles becomes filled to and above the riffle tops, the mineral passes off the table with the tailing or lighter material before it can be delivered by the table motion to the proper discharge point.

To regulate a feed that will keep a riffled table between the points of not sufficiently bedded and overbedded (which are not very far apart), is no easy performance, and it is rendered doubly difficult by the varying metallic content of the pulp fed.

It is not often that favorable conditions for feeding a riffled

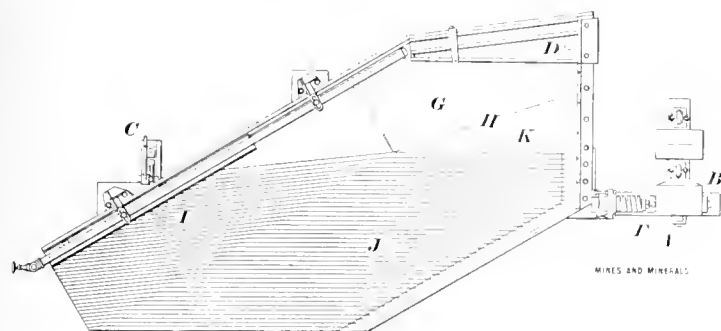

FIG. 2. PLAN OF DIAGONAL-PLANE TABLE DECK

table deck can be secured in practice; and when they are, the riffle proceeds to upset the whole business in hand. As the pulp reaches the first riffle it is forced over it by its own momentum; and this process is repeated at each succeeding riffle. In passing over each, the entire mass of the pulp is disrupted and shaken up. Whatever settlement and stratification of heavy particles has taken place between the riffles, is to a large extent destroyed. Each time the pulp is forced over a riffle it is an even chance whether the lighter or the heavier particles reach the deck first. They may drop from the top of the riffle and reach the table together, in which case the lighter particles become mixed and imbedded with the heavier, and are unable to stratify according to their specific gravities before they again meet an obstacle to their proper settlement in the form of another riffle. In other words, the work of settling and stratifying the various minerals in the ore is upset and retarded as many times as there are riffles on the deck of the table.

Another defect in the construction of some concentrating tables is that the line of motion of the table is parallel to the riffles upon the deck of the table, hence there is no action to counteract the downward flow of the heavier minerals and aid in their separation from the gangue by the dressing water.

A series of experiments extending over a period of 6 years was conducted to obtain the best means of concentrating minerals by the use of a wet reciprocating table. They culminated in a table differing radically in construction from the riffled table with parallel motion. A view of the table is given in Fig. 1.

The deck of the table is composed of a plain, non-riffled surface, and what might be termed a slightly riffled surface. The plain, non-riffled portion of the table is formed by two planes of different inclinations to each other, meeting in a line diagonal to the line of motion of the table, and for this reason has been named the diagonal-plane table deck. The planes in question form a basin in which the minerals of the greatest specific gravities are stratified previous to their discharge upon the riffled portion of the deck.

Referring to Fig. 2, which is a plan of the table deck, *A* and *B* are the stroke adjustments, and *C* is the tilting lever. The pulp, which enters the launder through pipe *D* is fed along the upper edge of one plane and on a line parallel to the table motion. During the travel of the pulp down the gentle incline of this plane *G*, which may be called the receiving and settling plane, the heavier minerals in the pulp settle and slide gently on the surface of the plane, to the line of intersection,

H, of the planes forming the basin. Along this line the most important action of the whole operation takes place; namely the stoppage of the heavy portion of the pulp flow by the rising plane *K* forming the lower section of the basin, and the carrying onward of the lighter or tailing portion of the pulp by the wash water. All these actions take place simultaneously with the discharge of the concentrate from the settling basin by the motion of the table.

The degree of inclination of the settling planes to each other, and the angle of their intersection to the line of the table motion, is of importance in securing the above results.

The practice of settling and stratifying by means of a settling basin provides for the disposition of a very wide range in quantity of metallic contents. There are no confining limits other than the limits of the basin itself. The basin does not require "bedding" and is very difficult to overfeed. It settles and discharges whatever quantity of metallic particles the ore may furnish.

The riffled surface of the deck is divided into two sections, one for the reception of the concentrate, *I*, Fig. 2, and the other, *J*, for the tailing. The riffles on the concentrate section are very thin, being but $\frac{1}{2}$ inch high. As the concentrate is discharged from the settling basin on this portion of the deck, the low riffles allow it to spread and enable any gangue in it to form a thin upper stratum, which is easily washed away by the dressing water. As the metallic mineral emerges from the settling basin upon the thinly riffled section of the deck, it is, by reason of the line of table motion being diagonal to its line of settlement, driven not only forward but upward against the inclination of the deck, thus counteracting the tendency of the dressing water to wash the concentrate into the tailing section.

The tailing from the settling basin does not come in contact with the riffles until it has been washed entirely free of mineral. These riffles act simply as retarders to prevent the too rapid discharge of the tailing and the washwater from the non-riffled section. They have nothing to do with the stratification of the minerals. That the table motion may be adapted to a variety of pulps, the eccentric actuating the table is mounted upon an adjustable pin, and may be placed more or less off center.

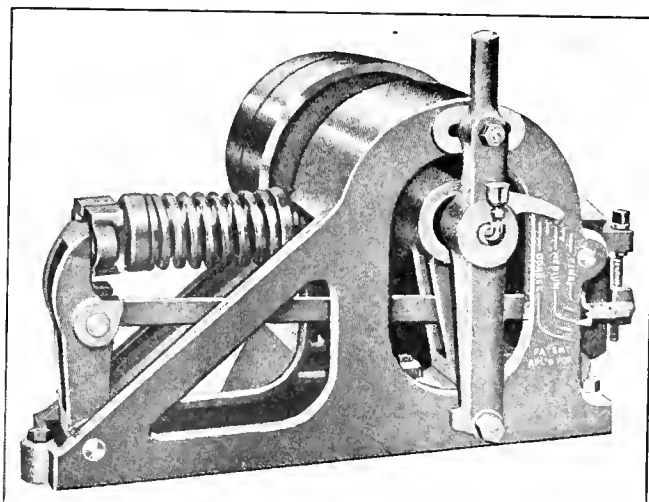

FIG. 3. HEAD MOTION OF DIAGONAL-PLANE TABLE

This adjustment, combined with the stroke adjustment, provides for more than 200 different movements, ranging from a very mild kick and long stroke to a very sharp kick and short stroke, or any combination of movements between these extremes. As a guide to the unskilled operator there is an index plate, shown in Fig. 3, based upon the size of the material, which is of great assistance in selecting a movement with which to start.

Magnetic Separation of Ores

A Description of the Process as Used in Mills at Joplin, Mo., and Galena, Illinois

By Lucius L. Wittich*

Electric magnets of varying power are employed successfully in separating iron from zinc ores in the Missouri-Kansas-Oklahoma district, and in the zinc districts of Wisconsin and Illinois.

The Joplin Separating Co., operated by W. P. Cleveland and W. S. Picher, of Joplin, Mo., is running two plants, one at Joplin, the flow sheet of which is shown in Fig. 3, and another of larger capacity at Galena, Ill., shown in Fig. 3.

Due to the comparatively small production of zinc ores containing a heavy percentage of iron sulphide in the Missouri-Kansas-Oklahoma district, the Joplin plant sometimes is forced to close for lack of material on which to work, but as a rule

It is therefore evident that the presence of iron not only reduces the market price of the ore, but it reduces the demand for the ore. Where the percentage of iron is high, 20 or 25 per cent. for example, it is possible that when a certain smelter wishes this grade of ore, the actual basis price may be higher than that for good ore, although the price paid for the ore will be low, the deduction of \$1 a unit for the iron bringing the market value down to where there can be comparatively little profit for the producer.

On the contract system of selling zinc ores the penalties are not so high, but as comparatively little ore is yet being sold on this system it is not making a material difference in the methods that have been in vogue since the district began producing.

Through the use of magnetic separators, the Joplin Separating Co. is enabled to purchase iron-zinc ores, and, by a system of roasting and separating, produce high-grade zinc concentrates which sometimes command a premium over the prevailing basis price, as the smelters, to counterbalance their system of penalizing, pay \$1 per ton above the basis price for each unit of metallic zinc above 60 per cent.

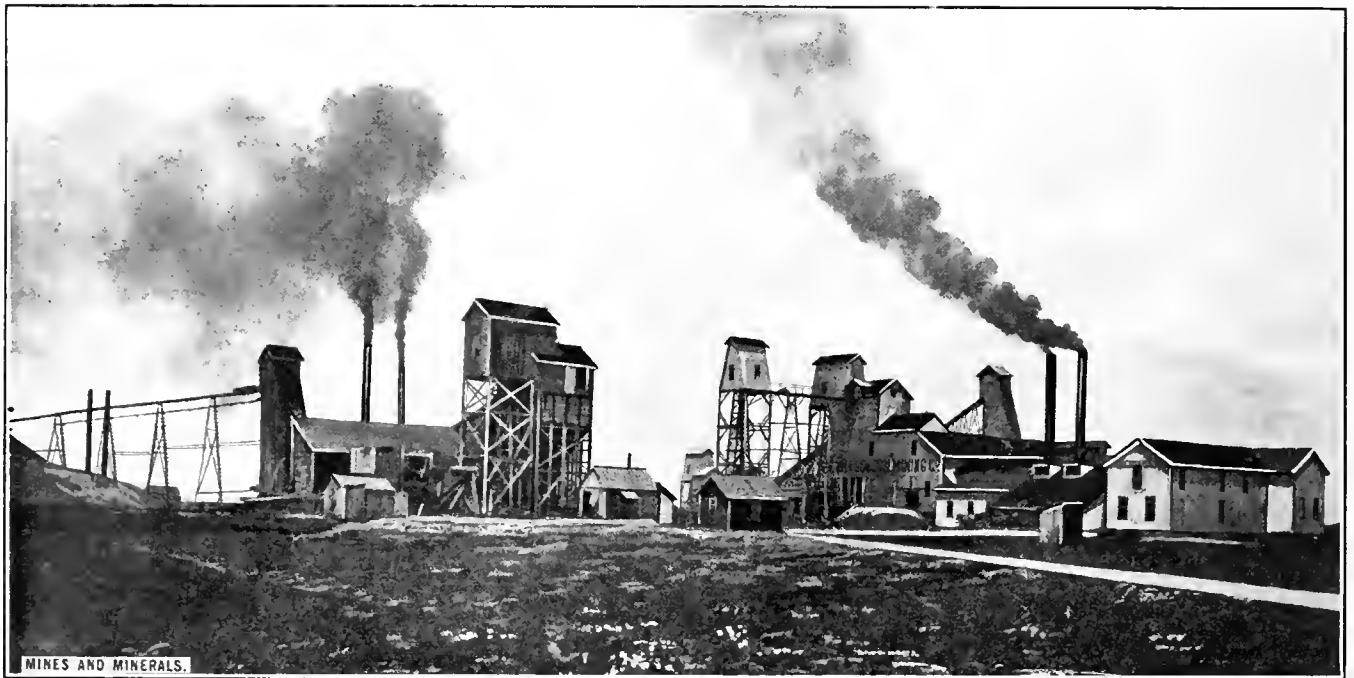

FIG. 1. MIAMI, OKLA. SEPARATING PLANT

enough low-grade ore can be obtained to keep the plant in operation.

The new camp of Miami, Okla., shown in Fig. 1, is a heavy producer of zinc ore running high in iron, and from this camp much of the ore treated by the Joplin Separating Co. is secured. Galena, Kans., also produces a comparatively heavy tonnage of ores running high in iron. In the early days of the Galena camp, before a market existed for the heavy iron ores, hundreds of tons of blende were discarded; and even at this late day, when many of the old-time dump piles have been reworked, it is possible to find enormous heaps of boulders rich in zinc ore, but so heavily impregnated with pyrite that the early-day operators found it inadvisable to attempt the concentration of the product. Iron in zinc concentrate is penalized at the rate of \$1 per unit; one unit of iron, however, being permitted without making a deduction in the price. For example, zinc ore is purchased on a basis of 60 per cent. metallic zinc. If the basis price is \$40 a ton, ore of 60 per cent. zinc and 1 per cent. or less of iron would bring \$40 a ton; but ore carrying 10 per cent. iron would be penalized \$9 a ton, leaving the price paid \$31.

* Joplin, Mo.

When roasted, the sulphide of iron in the zinc ore becomes magnetic and responds to the attraction of the saturated magnets, beneath which it passes on belt conveyers.

Referring to Fig. 3, it will be observed that the plant is equipped with ordinary jigs and tables, such as are found in the concentrating plants of the district. As low-grade ores contain sand, chatts, and galena, in addition to pyrite, and as the presence of these substances also is penalized by the buyers, it is important that the jigging process be employed to free the ore from these impurities before it is sent to the roaster. Where the ore has already been cleaned of sand, chatts, galena, etc., the rejigging process at the plant of the Separating company is not necessary, and in such cases the ore goes direct to the roasting ovens 3 instead of to the sizing screen 1 and the jigs 2.

The roasting ovens, of which there are two, consist of one firebox and three eyes each. In the first eye, nearest the furnace, three charges of 1,500 pounds each may be roasted in 12 hours; in the second eye from the furnace, two charges of 1,500 pounds each may be roasted in 12 hours; in the third eye from the furnace, one charge of 1,500 pounds may be

roasted in 12 hours. Thus the capacity of the plant is 18,000 pounds of ore from the roasters in 12 hours.

The eyes in which the ore is roasted are floored with brick. The fireboxes are at the outside ends of the kilns, the flames being drawn toward the flue stationed in the center of the two kilns. In this manner the fire sweeps over the ore that has been distributed evenly over the floors of the eyes. In a comparatively short time the ore in the eye nearest the fire will become a glowing red; while a longer period will be required to heat the ore in the eyes farthest from the source of the flames. At first the ore will throw off a flickering bluish flame, intermingled with the glaring red of the heated mass. The sulphur in the product is responsible for the bluish glare. As the time approaches for the removal of the ore the blue flames will disappear.

From the eyes the roasted ore is wheeled in barrows to the cooling floors 4, and when cooled is ready for the separator, first being wheeled to the receiving hopper 5, from whence it is elevated by a cup elevator 6 to a revolving screen 7. The upper half of the screen is equipped with wire mesh with openings $\frac{1}{2}$ inch square. The ore that passes through this feeds into a large hopper 8, which is divided into two parts by a partition running crosswise through the center. At the lower end of the revolving screen is a perforated iron mesh, the holes being $\frac{1}{8}$ inch in diameter. Ore passing through this also falls into the other part of the hopper. The object of the different

from the first magnets 11, beneath which the belt conveyer passes, goes direct to the waste pile and is of no further value save to be used in road making, sidewalk building, etc., and even for such purposes it is in little demand owing to its unattractive color. These weaker magnets range in power from 2 to 5 amperes, the variation being due to the different kinds

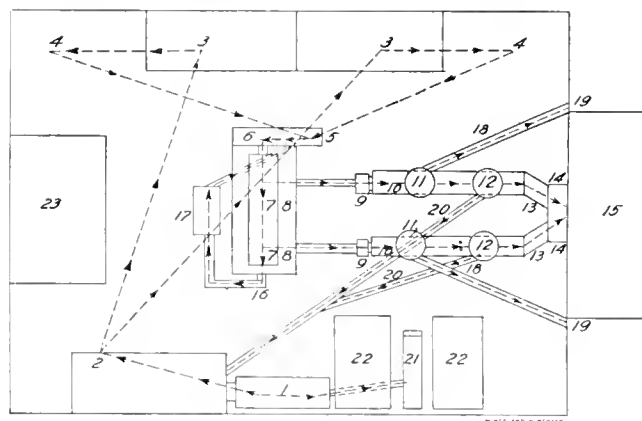

FIG. 3. FLOW SHEET

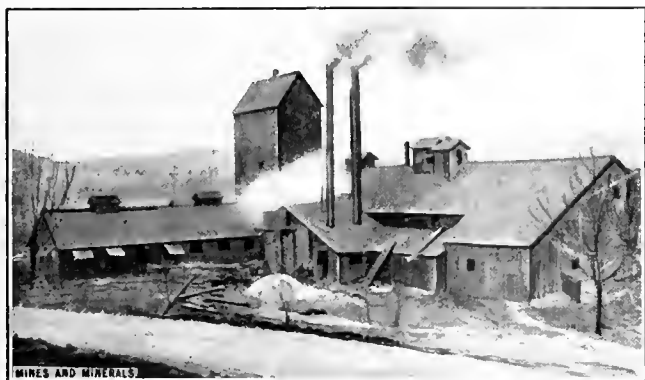

FIG. 2. GALENA, ILLINOIS, SEPARATING PLANT

sized mesh is to secure different sizes of ore for the two separators with which the plant is equipped. The oversize from the screen 7 passes to the rolls 17 via the launder 16 and thence back to the elevator 6 after it has been ground. In this manner the ore continues to circulate until it will pass through one or the other sections of the screen.

From the hopper the ore descends by gravity through launders to the distributing hoppers 9 at the upper ends of the belt conveyers 10. At the base of the distributing hoppers are spreaders on to which the ore falls and is conveyed in an even layer to the slow-moving belt conveyer beneath the magnets 11 and 12. One of these belt conveyers is 12 inches wide; the other 18 inches. They operate over wooden pulleys about 8 feet apart, and are prevented from sagging in the passage beneath the magnets by wooden rollers.

The magnets consist of cylindrical soft-iron shells which cover helices of copper wire. The shells are 20 inches in diameter, but differ in height, the first magnets beneath which the roasted ore passes being 10 inches high, while the second magnets—the more powerful ones—are 20 inches high. The magnets revolve slowly and the iron oxide which is attracted to their surface is scraped off into launders by means of brass knives, which cause it to fall vertically.

As it is imperative that the recovery of blende be thorough and yet contain as little iron as possible, a careful regulation of the electrical current is required. The iron oxide scraped

of ores treated. Some ores will respond to a slight magnetism while others require a more powerful force.

The object of the weaker magnets therefore is to attract only the iron particles that are virtually free from zinc ore, although a small percentage of ore is bound to escape with the waste through the launders 18 to the tailing piles 19.

As the belt conveyer passes beneath the revolving magnets its surface is about $\frac{3}{4}$ to 1 inch beneath the surface of the magnet, and across this space the iron particles rise to the magnetized zone of the apparatus. This zone is $\frac{1}{8}$ inch wide, is near the extreme outer edge of the round face of the magnet, extends entirely around the magnet, and represents the gap between the positive and the negative poles, this narrow strip being the one point of the entire surface to which the iron particles are attracted. As the magnet swings around, bringing the clinging particles of ore against the brass knife, the product is scraped loose.

Passing on beyond the first magnet, the belt goes beneath the second magnet which ranges in power from 9 to 12 amperes and attracts a heavy volume of particles that contain some zinc. A pin point of iron attached to a piece of zinc 50 times heavier than the iron, will respond to the magnetic force and jump upward to the magnetized zone. The ore that succeeds in getting beyond the second magnet and reaching the trough 14

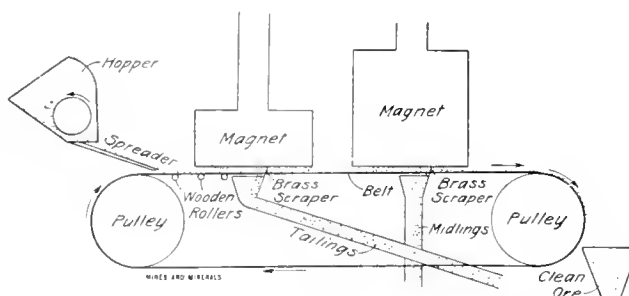

FIG. 4. SECTION THROUGH MAGNETIC CONCENTRATOR

at the end of the belt conveyer is therefore as free from iron particles as it is possible to get it. The cleaned ore passes to an elevator 14 and is lifted to the clean ore bin 15. It is in demand, as it is equal to the ores produced from the high-grade mines of the district.

To discard in the waste pile the particles that adhere to the powerful magnets 12 would cause a loss of zinc, therefore, the

scrapings, not going to the tailing pile, fall into launders 20. The product of rod, 1 and 21, that passing through a mesh of 3 millimeters going to the jigs, while that passing through a 1-millimeter and a 7-millimeter mesh goes to the tables. The overflow goes to rolls 17, where it is reground and returned to the magnetic separators.

That the rehandling of the middlings from the magnets 12 results in a great saving of zinc is the belief of the operators of the plant. Whether the small iron particles are broken loose from the zinc during the process of jigging and are washed away with the tailings, or whether the separation is effected on the tables or at the magnetic separator, has not been determined.

While the company operates its plant with electricity obtained from a local power company, it operates its own dynamo, stationed in a room designated as 23, in Fig. 1, and the magnets are charged with electricity from this dynamo.

Visitors to the plant are warned to leave their watches outside, as the magnetic influence permeates the air for a great distance from the magnet. A watch brought within the electric zone will become saturated with magnetism and will be useless as a timepiece until it is demagnetized, which process will cost the owner from \$2 to \$3. A magnetized watch may run 2 hours fast in the forenoon and 2 hours slow in the afternoon.

The plant at Galena, Ill., is equipped with five separators instead of two, as is the plant at Joplin. At the Illinois plant automatic roasters and cooling devices are employed and other equipment used which tends to expedite the process of separation. The Illinois plant is within 6 miles of many zinc mines whose ore carries usually high iron.

采 采

Swinging Rock Dump at Cokedale

Under any circumstances the handling of the waste rock at a coal mine is a constant source of annoyance and expense. If stowed underground the services of a driver and mule in addition to those of the rock gang are necessary. These men are taken from their regular duties, and the haulage of coal is not infrequently seriously interfered with. If brought to the surface, anywhere from two to six men may be needed on the dump, men who work frequently but half time or less, yet who must constantly be on hand to take care of the rock cars as they come out. Again, if the cars are dumped from the end of a

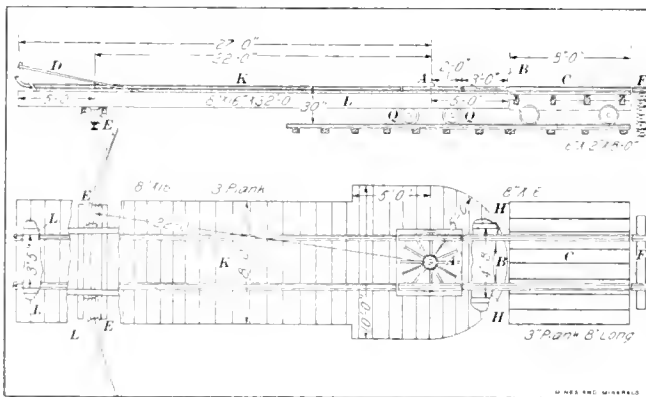

FIG. 1. SWINGING ROCK DUMP

trestle, as is almost invariably the case, this has to be constantly moved forward if there be any large amount of rock.

To save labor and this constant moving, the revolving rock dump, used at the Cokedale mine of the Carbon Coal and Coke Co., near Trinidad, Colo., may prove of interest. It consists essentially of a swinging truck, K, composed of two pieces of 8" x 16" Oregon pine, L, 32 feet long, upon which is laid a platform of 3-inch planks, and upon which in turn are laid

the rails. The rear end is supported by a four-wheeled truck, upon which the platform is pivoted at A. The outer end is supported upon wheels, E, which travel upon rails bent to a radius of 22 feet. As there is an overhang of 5 feet at the outboard end, the total radius of action is 27 feet. The total width of the dump made by this device is thus 54 feet, and, consequently, the dump needs to be moved forward much less frequently than is the case in the old fixed dump where the width of the embankment rarely exceeds eight feet. There is, of course, a great saving in the amount of trestle required. The arrangement of timbers at the outboard end, D, is for the support of the chain which opens the latches in the end gate of the car.

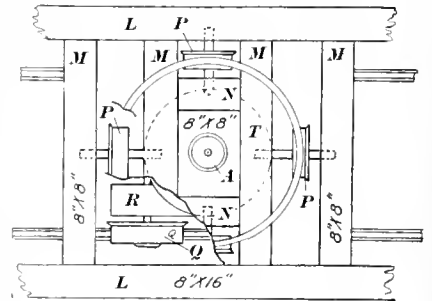

FIG. 2. TURNTABLE

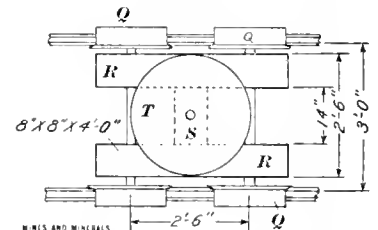

FIG. 3. TRUCK

The construction is very simple; one that any mine carpenter or blacksmith can duplicate. The forward wheels, E, are double and are made of two mine car wheels set face to face. The rear truck is supported upon four wheels Q, and T, Fig. 2, is a plate of 1/4-inch steel upon which the platform turns.

As the cars approach the dump wrong end first, a turn table is necessary that the end gate may be brought to face the dump. This turn table is shown in detail in Fig. 2. It consists of a heavy wheel taken from a wagon and mounted upon the same spindle, A, as that upon which the rear truck of the platform turns. The outer rim of the wheel bears upon four mine car wheels, P, set in a frame. This frame in Fig. 2, rests immediately upon the truck frame shown in Fig. 3. Upon the upper side of this wheel are bolted short lengths of mine rails, thus forming a perfect turn table. The cap shown at A, Fig. 1, is intended to engage the axle of the car to prevent its overrunning the table. The timbers, M, M, etc., where they engage the main floor beams, L, L, are supported by stirrups of bar iron and the same is the case where the shorter pieces, N, N, engage those marked M, M, etc. Stirrups are also used to support the center block, S, which carries the spindle, and also on both ends of the axles of the four wheels, P, P, etc.

The rear truck, C, carries the rails from the cribbing, F, to the swinging truck. These rails on C are loose at the outboard end, so that the swing truck may turn under them. This truck is not absolutely necessary, as these loose rails may be laid upon the cribbing at F, but it saves some time in moving the machine forward.

Two men are able to handle 100 cars of rock per day, where formerly six were required. This is very good work, as the cars have to be moved from and returned to the tippie by hand, a distance of about 100 feet, besides being turned twice on the table A.

We are indebted to Mr. Jacob Spahr, outside superintendent, for the description of this interesting device.

采 采

One of the most widely known of the rarer metals is tungsten. The production of this metal in the United States, however, is not large, as a little of it goes a long way for some of its most important uses. The principal uses are in electric lamps and as an alloy for special steels.

Making Gasoline from Oil Well Gas

Methods by Which a Valuable Product Is Recovered from What Has Been an Absolute Waste

By F. W. Bradu, *Sc. E.*

A striking example of waste has always been found in the great oil and gas fields of Ohio, West Virginia, and Pennsylvania. This does not mean that the oil has been wasted deliberately, for the supply is cared for remarkably well, but the direct loss has been through accident and carelessness, while the indirect loss has been from the light vapors passing off from the storage tanks, and the immense quantities of gas escaping from the wells. A visitor to the oil fields has always been impressed with the loss of gas, and "Why don't you do something with it?" has always been the commonplace inquiry. On the other hand, the habits of the oil fields had lapsed into a state of indifference, having for the most part become resigned to a loss that they believed could not be prevented. Any one with a technical instinct who visits the eastern oil fields today will experience a feeling of relief, for the newest of the new things in oil production is the perfection of a process for manufacturing gasoline from the gas from oil wells. These plants are located here and there on the farms wherever a group of wells can be worked to the best advantage. The gasoline is shipped in 50-gallon iron barrels which are hauled by wagon to the nearest railroad station, while the by-product gas is turned into the pipe lines that for years have distributed the high-pressure natural gas supply.

It is stated briefly for the benefit of the reader that oil development is going on continually. Each season sees some new field or oil excitement where production is booming. For examples of this kind, see notes on the Brooke County oil fields in *MINES AND MINERALS*, November, 1907; also the Follansbee field, in December, 1908, and the Steubenville field in October, 1909. At the beginning, most of the wells are self-flowing and some of them are real "gushers," producing five or six hundred barrels, or more, the first 24 hours; most of them, however, make less than one hundred barrels; but the decrease of production is rapid and soon all the wells become

reverse is the case, and practically all the oil wells close their careers as gasers.

Now it is this gas from the oil-bearing sands that has made the bulk of the waste. Especially has this waste been too bad where an oil well has been abandoned and the gas has been burned on the spot from the open pipe, or has escaped freely in the air. Millions upon millions of cubic feet of nature's best fuel have thus been disposed of. The final choking up of many abandoned oil wells by salt that encrusts in the casing

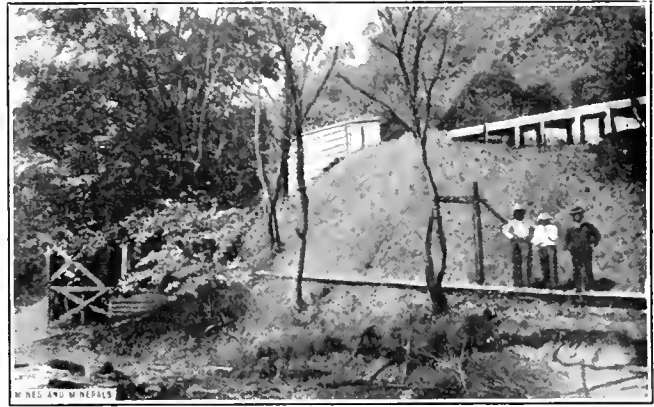

FIG. 2. GAS COOLER, ACCUMULATOR, AND LOADING HOUSE

will really be a boon to posterity. Not only has there been a direct waste of this kind of gas, but also there has been an indirect waste in the use of the gas piped from the oil wells. In the long pipe lines it has been a common occurrence for gasoline to collect wherever a down bend or pipe would trap it. Then the reevaporation of the gasoline will produce a freezing effect that will clog the pipes with ice where water has collected. This reevaporation may take place where the gasoline flows from a leak in the pipe and probably within the pipe also. The freezing of the gas pipes from this cause has been annoying, and it was due to this trouble that the apparatus for manufacturing gasoline from the gas was developed.

The process depends upon the condensation and liquefaction of gases—the direct processes being dependent on the laws governing the compression and refrigeration of the gas. The present plants are equipped with a refinement of the various apparatuses that have been perfected after a considerable experimentation with one thing and another.

The general arrangement of a gasoline plant in a deep hollow on Titts Run, near Wellsburg, W. Va., are shown in Figs. 1, 2, and 3, and a plan view of the arrangement of the apparatus in Fig. 5. This plant has a capacity for treating 150,000 cubic feet of gas in 24 hours, and produces from 500 to 800 gallons of gasoline having a gravity of 92° Baumé.

The power plant is housed in a one-story galvanized-iron building, 30 ft. × 40 ft., with the floor and foundations of concrete. Two direct 35-horsepower gas-engine-driven air compressors, made by the Bessemer Gas Engine Co., compress the gas. The first engine, which may have a piston varying from 6 to 12 inches, draws the gas from the piping system connecting all the available wells in the neighborhood. From a partial vacuum of 15 inches the gas is compressed to 20 or 30 pounds. It then passes through a water cooler to the second engine, which has a 4½-inch piston, and which compresses to 150 pounds or over. The final pressure must be determined by trial, as the process depends considerably upon the quality of the gas and the refrigeration treatment. Thus in this plant 150 pounds compression was found to produce more gasoline than did 250 pounds compression.

The gas at 150-pounds pressure passes through an 80-foot water cooler, and then through a double 80-foot gas cooler, the latter using the by-product gas for cooling. The collecting

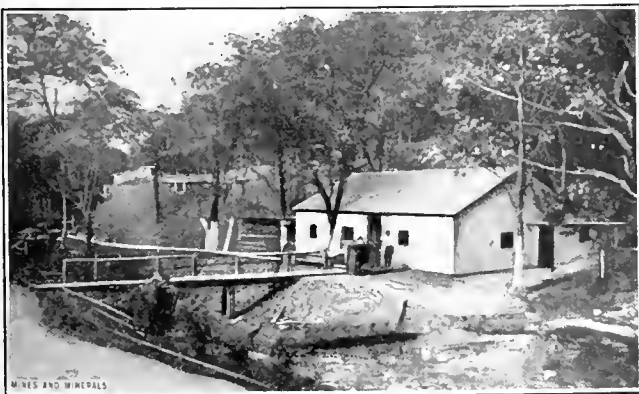

FIG. 1. GASOLINE PLANT

"pumpers." At first the pumping is daily, then about twice a week, and finally a settled system of pumping once a week, or once in 10 days or so, is kept up for several years with those wells that continue to produce oil, the quantity in many cases averaging much less than 1 barrel per day. All this time, however, from the first strike of oil, and for long after the well is abandoned as an oil producer, there is a flow of gas from the well. In some cases the first strike was a "gaser," which afterwards turned to an oil producer. Generally, though, the

and separating tank is of heavy boiler plate construction and resembles a 40-horsepower vertical boiler. The saturated refrigerated gas under a pressure of 150 pounds or over, enters the side of the accumulator tank at a point about two-thirds its height, measured from the bottom. A baffle plate riveted in the tank deflects the flow and precipitates the gasoline. The accumulation of gasoline is shown by a gauge glass, and periodically the attendant blows it into a storage tank of 120-barrels capacity. A similar storage tank, located below the first one, is shown in the foreground of Fig. 3. The storage



FIG. 3. STORAGE TANK, LOADING HOUSE, AND MAGNETO BUILDING

supply stands at about 20 pounds pressure. These tanks, of heavy boiler-plate construction, are erected in a horizontal position. From the stock tanks the gasoline is loaded into iron barrels of about 50 gallons each. The loading, however, is made by weight. The barrels weigh 75 pounds, and 270 pounds of gasoline is put in, making a total shipping weight of 345 pounds.

The iron barrel is placed on a platform scale and balanced. A piece of $\frac{3}{4}$ -inch hose is attached to a valve plug on top of the dome of the storage tank and the other end inserted in the bung hole of the barrel. A pipe leads from the valve plug to near the bottom of the tank, so that the gasoline is forced by the gas pressure into the barrel. As a cleanser, it is par excellence and at the works is as plenty as water. The gasoline is cool, and to bathe one's hands in it on a hot day gives a delightful feeling. The storage tanks have safety valves, and the blow-off gas is turned into the gas supply mains.

The loaded barrels are hauled by wagon, eight barrels to the load, 2 miles to the freight station at Wellsburg. The wholesale price of the gasoline f. o. b. cars at Wellsburg ranges from 9 to 12 cents per gallon. Most of the product is handled by the Petroleum Products Sales Co., Cleveland, Ohio.

The gas engines are of the tandem type and supplied with two flywheels. The gas-engine cylinder is at the head end and the gas compressor cylinder next to the crank end. Both the engine and compressor cylinders are water-jacketed. The crank case on some of these engines is closed and has a vent pipe leading above the building; thus, any gas leaking from the cylinders will be carried out of the building and the danger from fire or explosions lessened. The make-and-break spark system is used for ignition, and a friction-driven magneto for each engine is located in a small building some 100 feet distant. A small gas engine operates these magnetos and also the generator for lighting the plant. An air starting outfit, consisting of one air pump compressing to 150 pounds, air receiver, starting valves, pressure gauges, etc., makes the starting of these large gas engines an easy and a safe operation. About 2 pounds gas pressure is used for the gas-engine service. A regulator placed outside the building is necessary to deliver the fuel at a uniform pressure.

Cooling System.—All the engine and compressor cylinders are water cooled. The gas as it comes from the wells is prob-

ably at 60° F. The heated gas from the first compression goes to a water cooler consisting of a concrete vat 20 ft. \times 4 ft. \times 4 ft. A continuous flow of cool water passes through this tank in which a 10-inch pipe is laid lengthwise along the middle and to which the 3-inch delivery pipe from the first compressor is attached at one end, while to the other end an inlet pipe to the second compressor is attached.

The high-pressure gas from compressor No. 2 passes first through an automatic separator that removes any lubricant that may be carried over from the compressor. It also catches any gasoline that may drain back from the second cooler.

The second cooler is 80 feet long and consists of a concrete tank like the intermediate cooler. A 10-inch pipe is placed lengthwise of the tank. The arrangement of the piping system for the second cooler and also that for cooler No. 3 is shown in Fig. 5. The 2-inch delivery pipe enters a special fitting at the rear end of the 10-inch pipe, and the water-cooled gas passes out a 3-inch pipe 80 feet distant. This 3-inch pipe enters the end of an 80-foot length of 6-inch pipe, and returns through a second 80-foot length of 6-inch pipe and thence to the accumulator tank. From the gas space in the top of the accumulator tank a pipe leads to a gasoline trap which collects any gasoline that may be carried over from the accumulator and returns it to the stock tank. This trap is also fitted with a pop safety valve that relieves the accumulator from any over pressure and delivers the gas that may be blown off to the fuel-supply gas mains. Above the gasoline trap the by-product gas passes through a reducing valve of Lunkenheimer make and enters at low pressure the lower 80-foot branch of the 6-inch gas cooler. This No. 3 cooler is made up of a loop of 6-inch pipe laid in a box packed with sawdust. The peculiar design of the cooling system makes it necessary to use some specially designed pipe fittings. The cooling effect of the expanded by-product gas is considerable, as it flows 160 feet through the 6-inch pipe that encloses the 160 feet of 3-inch pipe carrying the compressed gas to the accumulator. From the 6-inch gas cooler, the expanded gas goes to the 80-foot water cooler and passes through a 3-inch pipe laid lengthwise through the center of the 10-inch pipe. From cooler No. 2 the by-product gas goes through a 2-inch pipe to the gas engine feed-line. The by-product gas not used by the plant goes into the natural gas mains and is sold. The overflow water from



FIG. 4. HAND RIGGED PUMPING HEAD
A, Connecting rod; B, Pump box; C, Pump rod; D, Lifting arm; E, Gin pole.

the concrete tanks flows by gravity to the water-jackets of the engines and compressors. The by-product gas is a blue-flame gas that is more desirable for fuel and lighting than the raw gas, as it does not deposit any soot or blacken at all the furnaces, gas mantels, cooking utensils, etc. By-product gas is sold to the Tri-State Gas Co., which has pipe lines connecting the oil and gas territory. The price paid is 4 cents per 1,000 cubic feet. The retail price of the gas for household use is 25 cents per 1,000, and for factory use a discount is given from the 25-cent rate.

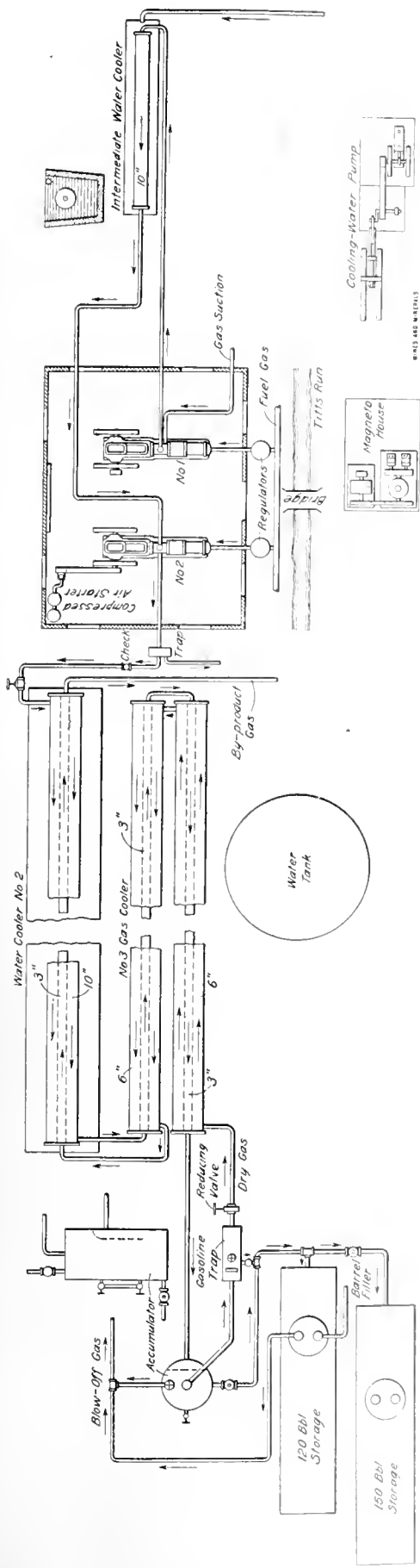

FIG. 5. PLAN OF GASOLINE PLANT

The partial vacuum produced by the first compressor as it draws its gas supply from the wells aids both the oil and the gas production; in fact, in some cases the gas is given to the gasoline plants, as the increase of oil due to the vacuum is quite an item to the well owner. At the same time, however, the owner draws back all the by-product gas he needs for pumping the oil.

The vacuum in the field lines is one of first importance in gasoline production. So great is this feature that in some gasoline plants a special independent low-stage vacuum pump and gas compressor has been installed so as to regulate the field pressure and increase the production. This machine can be operated at any desired speed necessary to keep the pressure conditions constant. With this low-pressure compressor 24 inches or more of vacuum can be held on the wells, and at the same time the efficiency of the regular compressor units not lowered. The advantages observed from the use of the vacuum system have led to the reopening of abandoned oil fields, not for the oil but for the gas from which to make gasoline.

The cooling water is taken from Titts Run, which flows by the plant, and it is also pumped from a nearby abandoned oil well. The pumping-head rig is shown in Fig. 4. A 3-horsepower gas engine housed at the right of the rig does the pumping. The engine is belted to a jack-shaft carrying tight and loose pulleys. A crank on this jack-shaft gives motion to the horizontal connecting-rod of the pump rig. This rig is made from discarded timbers from oil-well derricks. Sixty feet of well rods are used, and the stroke is about 30 inches, at 15 strokes per minute.

The business of making gasoline from natural gas is necessarily a hazardous one. It is a new business, and this, coupled with the usual combinations of ignorance and carelessness, makes a list of accidents that one would naturally expect. Even the empty barrels have exploded when standing exposed to the hot sun and with the vent plugs set tight. On one occasion an empty went up when standing on the freight station platform. The heavy iron head was bulged like a scoop from a grocer's scales and knocked a section from the body of an express wagon as it flew into the freight yard. The heavy iron ring under the crimp over the barrel head was pulled apart and thrown some distance over the tracks. A special design of sockets and double incandescent globes are used for lighting the plant. The loading house and storage tanks are erected at a considerable distance below the compressor house. Those old in oil-well service have become accustomed to handling nitroglycerine, and while they respect it, they treat it with a feeling of contempt. On the other hand, gasoline of from 92° to 100° Baumé is a new thing to them, and they have got "burned" as a consequence. Therefore, to hear an operator about a gasoline plant remark that he would rather carry "nitro" than gasoline is evidence of the fear in which it is held.

Gasoline can not be produced from all natural gases, at least not in paying quantities. As a general thing, the paying proposition is in connection with oil wells. In some cases the profits have been very great, and in the present state of the art it is not believed that the highest efficiency is yet attained. Any one can see that the process is one of conservation of the very best order, and fetches to the owner "a smile that won't come off." Though the process has been eagerly awaited, it is proper in most cases to test the gas. This can be done with considerable exactness and the amount of gasoline per 1,000 cubic feet of gas determined. Not only is the test necessary, but individual study must be given each prospect if the maximum efficiency of production is expected. The reason for this is that the gases in the different fields differ widely in their compositions; hence, the necessity of making both a physical examination and a chemical analysis to insure that the venture will not be a gamble. From the sample analyses already made, anything from zero to 9 or 10 gallons of gasoline per 1,000 cubic feet of gas could be expected. From 4 to 6 gallons is a good

average proposition. The plant will cost anywhere from \$1,500 to \$6,000.

The gas sample is collected in a ½-gallon bottle, or two 1-quart bottles, by filling the bottle full of water and inverting it in a pan of water. Attach 3 or 4 feet of rubber tubing to the gas cock and let the gas flow freely for 2 or 3 minutes so as to insure that it is dry. Then insert the open end of the tube under the mouth of the bottle. The gas will fill the bottle, driving out the water ahead of it. After the bottle is entirely full of gas, insert a tightly-fitted cork while the mouth is still under water in the pan or pail. Now remove the bottle, wipe dry and dip the corked mouth in a cup of melted paraffin. Finally, tie a piece of linen cloth over the cork and redip in the paraffin. Label the sample, carefully giving the name and address of the sender, and something of the character of the well; such as its depth, age, amount of oil it produces, name of the sand, amount of gas available, etc. Pack the sample bottle in excelsior or hay and ship via express to the chemical laboratory, which in the case of wells in the territory mentioned in the beginning of this article, would be the Bessemer Gas Engine Co., Grove City, Pa.

The name gasoline is a very broad term as commonly used. The name may apply to any oil from the heaviest kerosene to the lightest volatile production of over 100° Baumé made from natural gas. For gas engine use, the oil having a gravity of from 64° to 68° Baumé is most in demand at present. Heretofore the demand was for 72- to 76-degree oil, but there has been a diminishing of the supply. The lightest qualities ranging from 90° to over 100° Baumé, and which are made from natural gas, are of great purity and are perfect solvents for the heavier oils produced by the fractional distillation process from petroleum. Hence, perfect and homogeneous mixtures can be made easily so as to increase the weight of the high degree oils and thus produce any desired grade. Herein lies another great boon from the newly perfected process. Otherwise the use for the high-degree oil would be chiefly for lighting and in the arts. Also as these very light oils are difficult to store and most dangerous to handle, the mixtures with heavier oils serves greatly to save the supply.

采 采

Catalogs Received

THE ALDRICH PUMP DEPARTMENT, Allentown, Pa., Bulletin No. 21A, The Aldrich Vertical Quintuplex Electric Mine Pump, 12 pages.

AMERICAN PULVERIZER Co., St. Louis, Mo., folder describing screens and pulverizers.

THE BARCOCK & WILCOX Co., 85 Liberty Street, New York, N. Y., The Rust Water-Tube Boiler, 52 pages.

BALDWIN LOCOMOTIVE WORKS, Philadelphia, Pa., Record No. 69, Mallet Articulated Locomotives for the Atchison, Topeka & Santa Fe Railway System, 24 pages; Record No. 70, Walschaert Valve Gear, 32 pages.

EASTERN MFG. Co., Elmira, N. Y., three folders describing wooden water pipe.

GOULDS MFG. Co., Seneca Falls, N. Y., Goulds Single-Stage Centrifugal Pumps, 8 pages.

GARDNER CRUSHER Co., 556 West 34th Street, New York, N. Y., Gardner Crusher, Disintegrator, and Pulverizer, 4 pages.

GENERAL ELECTRIC Co., Schenectady, N. Y., Bulletin No. 4825, General Electric Switchboard Instruments, Types R-4 and R-6, 10 pages; Bulletin No. 4827, The G. E. Air-Flow Meter, 10 pages; Bulletin No. 4819, Alternating-Current Switchboard Panels, With Oil Switches on Panel, 42 pages.

HULL MFG. Co., Scranton, Pa., "A Regulator That Regulates," 4 pages.

HOMESTEAD VALVE Co., Pittsburg, Pa., Homestead Valves and Locking Cock, 16 pages.

LUITWIELER PUMPING ENGINE Co., Los Angeles, Cal., Luitwelier Pumping Engines, Non-Pulsating, 36 pages.

MESTA MACHINE Co., Pittsburg, Pa., Steam-Hydraulic Forging and Bending Presses, 23 pages.

THE MONARCH ENGINEERING AND MFG. Co., Baltimore, Md., Monarch Modern Melting Furnaces, 10 pages.

MCKIERNAN-TERRY DRILL Co., 115 Broadway, New York, N. Y., Hammer Drills, 12 pages.

THE OHIO BRASS Co., Mansfield, Ohio, Catalog K, Ohio Valves and Steam Specialties, 56 pages.

OLIVER CONTINUOUS FILTER Co., San Francisco, Cal., The Oliver Filter, 16 pages.

E. KEELER Co., Williamsport, Pa., Boilers, 48 pages.

THE LINDE AIR PRODUCTS Co., Buffalo, N. Y., Catalog of Oxy-Acetylene Apparatus, 49 pages.

CHAIN BELT Co., Milwaukee, Wis., General Catalog No. 40, Elevating, Conveying, and Concrete Machinery, 278 pages.

STURTEVANT MILL Co., Boston, Mass., Sturtevant Crushers, 16 pages.

SULLIVAN MACHINERY Co., Chicago, Ill., Bulletin No. 66A, The Sullivan Rock Drills for Excavating Rock, 8 pages; Bulletin No. 66B, Sullivan Rock Drill Mountings and Accessories, 24 pages; Bulletin No. 66C, Sullivan Hammer Drills for Mining and Construction Work, 20 pages.

WILLIAMSPORT WIRE ROPE Co., Williamsport, Pa., Catalog No. 23, Describing Wire Rope, 54 pages.

HENRY R. WORTHINGTON, 115 Broadway, New York, N. Y., Worthington Type "D" Centrifugal Pumps for Low-Head Service, 12 pages; Worthington Centrifugal House and Sump Pumps, 8 pages.

G. L. SIMONDS & Co., 801 Steinway Bldg., Chicago, Ill., Vulcan Soot Cleaner, 32 pages.

THE WESTERN MACHINERY AND MFG. Co., Denver, Colo., Bulletin No. 100, The New Western Stopping Drill, 16 pages.

ACKROYD & BEST, LTD., Morley, near Leeds, England; and No. Arrott Power Bldg., Barker Place, Pittsburg, Pa.; Catalog E5, Safety Lamps, 34 pages.

SENECA CAMERA MFG. Co., Rochester, N. Y., Seneca Cameras, 76 pages.

STROMBERG-CARLSON TELEPHONE MFG. Co., Rochester, N. Y., Bulletin No. 1001, Despatcher's Signals for Electric Interurban Railroads, 12 pages; Folder for the Man Who Has to be Everywhere at Once.

Hazard Mfg. Co., Wilkes-Barre, Pa., Hazard Products, Insulated Wires and Cables, 48 pages; describing all kinds of wires, ropes, and cables made by the company.

采 采

Nova Scotia Oil Fields

The Maritimes Oilfields Co., Ltd., continued during 1910 developing the oil and gas territory in Albert County, New Brunswick. It is stated in the United States Consular Report that the company has drilled 11 wells, but owing to the pressure of natural gas only three wells have been "shot," which produce an average of 35 barrels of oil per day. The gas flowing from these wells is estimated at 40,000,000 feet daily. A pipe line will be laid to Moncton, to supply the city with gas for heating and lighting purposes.

Prior to the discovery of petroleum in Pennsylvania, the oil shale of New Brunswick, known as Albertite, was largely shipped to the United States, where it was used in the production of illuminating gas. The discovery of petroleum decreased the demand, and this, with the loss of valuable machinery, caused the operators to abandon the industry. A United States Consular Report states that recently a company with a capital of \$1,000,000 was incorporated to develop the oil-shale territory and it is said \$3,000,000 will be spent in its operations.

Equipment of the Poverty Gulch Mine

Specifications, Calculations of Capacity and Costs of Machinery and Buildings Required

By Chas. W. Henderson*

According to the assumption it is necessary to design a surface plant that will hoist 200 tons of ore daily from a depth of 1,000 feet.

The following is a well-known rule used in selecting electric hoists: L = pull on rope at drum with load at bottom of shaft in pounds = weight of ore + rope + skip; R = rope speed of hoisting in feet per minute; $H. P. = \frac{L \times R}{28,000}$

Lupton, Parr, and Perkins, on electric hoisting for haulage on inclines add 5 per cent. for friction.

In this case, L = skip, 1,300 pounds; ore, 1 ton, 2,000 pounds; 1,000 feet of $\frac{3}{4}$ -inch rope, 880 pounds; total, 4,180 pounds.

L on $22^\circ 42'$ slope = $4,180 \times .385 = 1,610$ pounds + friction, 161 pounds; total, $L = 1,771$ pounds.

With the proper motor, this hoist can be run at a speed of 600 feet per minute, and with a load of 1,771 pounds, the horsepower in either case being nearly the same, the advantage being that the hoist is 6.6 horsepower more powerful than necessary.

Cost, f. o. b. Denver, \$500; freight to Cripple Creek, at car-load rate (\$.55), \$18.15; total cost of hoist, \$518.15.

In hauling on an incline, the motor should be in excess of the maximum pull required by 45 per cent. to overcome a 20 per cent. friction of gearing and 25 per cent. for starting. The horsepower of the motor for this hoist should be $37 \times 1.45 = 53.7$ horsepower.

Cost f. o. b. Denver, \$384.90; freight to Cripple Creek, 3,260 pounds at 55 cents, \$17.95; total cost of motor, \$402.85.

For haulage, use the six strands of seven wires, Lang lay rope, as haulage rope has to take more wear and does not need to be so flexible. Lang lay ropes stretch less and are smoother.

Strength of rope required is as follows: Weight of skip, 1,300 pounds; weight of ore, 2,000 pounds; total, 3,300 pounds. Resolved on incline, $3,300 \text{ pounds} \times .385 = 1,270.5$, and doubling this for shock = 2,541 pounds; friction, 10 per cent., 127 pounds;

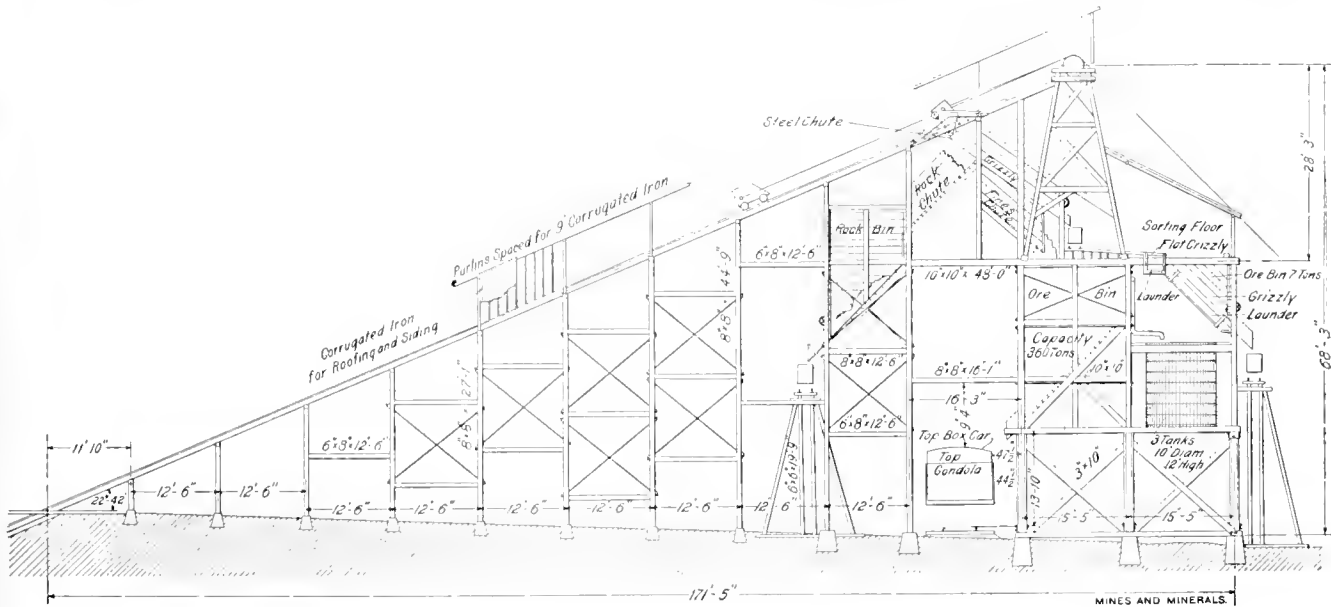

FIG. 1. HEAD-FRAME AND ORE BIN

If 200 tons are to be hoisted per day of 16 hours, in 1-ton skip, there would be 200 trips per 16 hours, or one trip every $\frac{16 \times 60}{200} = 4.8$ minutes.

In this case, it was decided to use a single-drum hoist. Allowing $\frac{1}{2}$ minute for delays at bottom of the shaft, and $\frac{1}{2}$ minute at dumping device, there remains 3.8 minutes to hoist and return, or 1.9 minutes for hoisting. $\frac{1,000}{1.9}$ feet = 526 feet (say, 600 feet) per minute = R .

The electrical horsepower necessary for this speed is

$$\frac{L \times R}{28,000} = \frac{1,771 \times 600}{28,000} = 37 \text{ H. P.}$$

The specifications for the hoist would be 37 horsepower, 2,710 pounds load; 450 feet per minute rope speed; 36-inch diameter drum; 17-inch drum face; capacity of drum, 2,800 feet of $\frac{3}{4}$ -inch rope; weight with single drum, 8,750 pounds.

These specifications give $\frac{2,710 \times 450}{28,000} = 43.6$ horsepower.

This hoist can be used by getting the proper motor for the hoist, the change in speed depending on the build of the motor, not on the build of the hoist.

* Part of Mr. Henderson's thesis.

weight of rope, 880 pounds; total, 3,548 pounds. Total possible stress, 4.39 tons.

The breaking strength of $\frac{3}{4}$ -inch steel wire haulage rope, six strands of seven wires, is approximately, in tons of 2,000 pounds, 9.3 tons. The allowable working strain is 3,920 pounds, and it cost 14 cents per foot, less 30 per cent.

1,500 feet purchased, cost, at Denver, \$147; freight, 1,320 pounds at 65 cents per 100, \$8.58; total, \$155.58.

The minimum size sheave is 48 in. $\times \frac{3}{4}$ in. (rope) = 36 inches diameter. Price with shaft and ball-and-socket boxes, \$45. Total weight, 430 pounds. Extra heavy, split, wood filled, cost plus freight (430 pounds at 65 cents, \$2.80), \$47.80.

The head-frame (four posts) is designed to be placed on top of the ore bin.

Though the skip and weight of ore is to be regularly sustained by the head-frame, it is designed to withstand the stress of a 2-ton skip and contents.

The calculations are as follows:

Live load stresses (2-ton skip): Skip (2-ton capacity), 2,000 pounds; ore, 4,000 pounds; total, 6,000 pounds. Resolved $22^\circ 42'$ incline, $6,000 \times .385 = 2,310$ pounds.

$2,310 \times 2$ (for shock) = 4,620 pounds; rope, 880 pounds; friction, 231 pounds; total, 5,731 pounds.

This force of 5,731 pounds pulling equally on rope to skip (22° 42' and on drum of hoist (at 45°) gives a resultant of 6,410. $2.5R - 4.33x = 0$. $x = \frac{2.5 \times 6,410}{4.33} = 3,700$ pounds, and $R - x = 2,710$ pounds. These stresses divided over two sides of head-frame, $\frac{x}{2} = 1,850$ pounds; $\frac{R-x}{2} = 1,355$ pounds.

Dead load stresses include: Weight of sheave+bearings, 450 pounds; platform and sheave supports on top of head-frame, 1,100 pounds; weight of roof and galvanized iron siding, 1,016 pounds; dead load=2,486 pounds. This dead load divided by 4 gives 621 pounds as the load supported on each post of head-frame.

In making allowance for wind pressure, wind loads are figured at 30 pounds pressure per square foot, which is equal to a wind velocity of nearly 80 miles per hour, and represents a hurricane.

The main timbers of the head-frame are 8 in. x 8 in., and are braced by 6 in. x 8 in. stuff. The details of the head-frame ore bins, and ore house are shown in Fig. 1.

The ore bin proper is designed for a capacity of 360 tons, and also designed to withstand the weight of the head-frame and the stresses of hoisting. The capacity is figured on a basis of 200 tons hoisted per day, of which 57 per cent. is to be shipped (114 tons), in 40-ton cars, or 120 tons daily, and the capacity for 3 days reserve is 360 tons.

The ore bin proper is 15 feet 5 inches wide by 50 feet long, the main supports being 10" x 10" timbers. There are three ore chutes designed to load at one time a car and a half at their quarter points. The chutes are designed also to load into box cars or gondolas.

The ore house includes the ore bin, head-frame, sorting tables, tripper (belt conveyor), grizzlies, tanks for settling washed fines, and also may include the trestle or approach from the shaft to the ore bin, with dumping device, and grizzlies for fines.

SPECIFICATIONS AND COST OF ORE HOUSE

Timber, 99,117 board feet, at \$20 a thousand.....	\$1,982.34
Wrought iron, 2,636.53 pounds, at 34 cents per pound..	85.69
Steel, 1,699.79 pounds, at \$2.90 per 112 pounds.....	44.00
Bolts, 522.83 pounds, at 9 cents, 55 per cent. off.....	21.17
Washers (malleable iron), 24 1/2 inch, \$9 per 100 pieces...	2.16
Washers (malleable iron), 22 1/2 inch, \$20 per 100.....	4.40
Washers (malleable iron), 378 3/4 inch, \$2 per 100.....	7.56
Washers (malleable iron), 214 3/4 inch, \$4.50 per 100.....	9.63
Washers (wrought) 112 1/2 inch, at .092 cent. per pound..	12.06
Washers (angle), 268 1/2 inch, at \$4.50 per 100 pieces.....	138.50
Cement, 50 barrels, at \$2.14 cubic yards sand, at 75 cents, 28 cubic yards broken stone, at \$1.....	1.44
Lagscrews, 36 1/2 in. x 4 in., at \$4 per 100.....	5.01
Lagscrews, 144 1/2 in. x 3 in., at \$3.48 per 100.....	1.90
Iron wood screws, 148 2 1/2 inches long, at 1.3 cents.....	5.70
Pulleys (hollow steel) six 3 inches long, at 95 cents.....	4.20
Chain, 3/8 inch (weight per 100 feet, 50 pounds), 52.5 pounds, at 8 cents.....	240.00
Gates, ten rack and pinion, 24 in. x 36 in., at \$24.....	1,055.16
Grizzlies, 458.75 square feet 3/4-inch screen opening, size 7 in. x 1/2 in. x 2 in., at \$2.30 per square foot.....	47.80
Shaft and bearings.....	256.20
Three tanks, each 12 feet high by 10 feet diameter, capacity, 205 barrels; weight, 2,180 pounds, at \$85.40.....	188.00
Pipe, 100 feet standard water pipe, 6 inches diameter; weight, 18.76 pounds per foot price \$1.88 per foot....	120.00
Four valves, straightway, 6-inch diameter, at \$30.....	1,045.67
Corrugated iron, No. 28, 8,104 square feet (8,104 + 10 per cent.), 8,904 square feet weight per 100 square feet, 69 pounds, 8,151 pounds, at 17 cents per pound.....	220.00
Freight, about 40,000 pounds at carload rate, 55 cents per 100 pounds.....	
Total.....	\$5,498.94

The skip is designed to hold 1 ton, or 21.5 cubic feet of Cripple Creek ore. It is made of 3/4-inch steel and is 2.5 feet wide, 2.5 feet high, and average of 4 feet long (3 and 5), capacity 25 cubic feet, the additional capacity being for safe loading. The track gauge is 33 1/2 inches, wheels 12 inches diameter, front wheels 3 inches, and back wheels 6-inch tread. The axles are bolted to the bottom of the skip, which is of the type generally used on long inclines.

A 1911 catalog gives skip No. 1, capacity, 25 cubic feet; thickness of steel in box, 3/4 inch; weight, approximate, 1,300 pounds. This is quoted at \$125, with \$15 extra for water valve. It is built of Swedish iron and steel plate, and the

wheels are of best chilled iron. Cost of the two skips purchased is \$298.20, of which \$18.20 is freight.

Information from a manager in Cripple Creek gives the fact that one stoping drill will break down 8 tons of ore. This is also checked by the report of the Portland company, showing 29 machines stoping, and an average for the year of 230 tons a day. Based on this practice, 200 tons of ore will need 25 machines, and a good safe margin is 12 additional machines on development. This is more than necessary during preliminary development work. It is estimated that 25 air-hammer drills take 25 cubic feet of air each at sea level. The multiplication factor for 25 drills at 10,000 feet altitude is 23.7; hence, 23.7 x 25 = 592.5 cubic feet per minute. Twelve 2 1/2-inch piston drills at air pressure of 90 pounds at drill take 80 per cent. of catalog figures, or 67.2 cubic feet each. Multiplication factor for 10,000 feet elevation is 12.1, which gives 813 cubic feet air per minute, or for both hammer and piston drills a total of 1,405.5 cubic feet air per minute. Allowing 5 per cent. for leakage brings the requirements to 1,480 cubic feet per minute. Assuming efficiency of 80 per cent., and the requirements amount to 1,850 cubic feet per air minute.

The size of a two-stage belt-driven compressor, weighing 50,000 pounds, for altitudes of 10,000 feet will be found by consulting catalogs to have about the following dimensions:

Size		Revolutions Per Minute	Piston Displacement Cubic Feet Per Revolution	Horsepower Required 100 Pounds Air
Air Cylinder Inches	Stroke Inches			
28 x 17	24	125	17.2	380

This gives an excess of 16.2 per cent. in capacity and the revolutions per minute can be increased to 150, giving an additional capacity above requirements of 39.5 per cent., a total reserve for future of 55.7 per cent. Cost f. o. b. Cripple Creek, \$5,620.

Assuming that 20 horsepower is required for 100 cubic feet of free air per minute, 20 x 18.5 = 370 horsepower.

For this compressor a 380-horsepower motor, weighing 45,000 pounds, completely boxed, is advised. This, f. o. b. Cripple Creek would cost \$3,477.50. The motor is to be three phase, 60 cycle, 440 volts, at 720 revolutions per minute.

As a service main, 1,660 feet of 4-inch air pipe, weighing 88 pounds per 100 feet and costing \$182.34, was decided upon, bringing the cost of air installation to the following: Compressor, \$5,620; motor, \$3,477.50; pipe, \$182.34; total, \$9,279.84.

All buildings, except powder house, which has brick walls and corrugated iron roof, are of ordinary balloon frame with corrugated-iron siding and roofing. The cost of surface buildings summed up is as follows:

COST OF SURFACE BUILDINGS

1.	Ore house.....	\$5,498.94	
	Cost of construction at \$8.50 per thousand sand board feet.....	\$42.00	\$6,340.94
2.	40 ft. x 15 ft., 600 cu. ft. erected, at 15 cents per cu. ft.....		90.00
3.	20 ft. x 20 ft., 400 cu. ft., at 10 cents.....		40.00
	17 ft. x 50 ft., 850 cu. ft., total cost, erected at 15 cents per cu. ft.....	\$ 127.50	
	Shafts, pulleys, and equip- ment of machine shop.....	\$1,000.00	
	One Bradford engine lathe, 14,500 pounds.....	800.00	
	Machine tools.....	500.00	
	One power driven forge.....	100.00	
4.	One 10 H. P. Westing- house induction motor.....	150.00	
	One Leyner drill sharpener, weight 1,494 pounds.....	1,000.00	
	One complete blacksmith outfit, weight 500 lb.....	40.00	
	One extra anvil, 100 lbs., solid wrought, at 15 cts.....	15.00	\$3,605.00
	Timber shed 115 x 10, 1,150 cu. ft. at 4 cents per cubic foot.....	46.00	
5.	One D. E. W. timber framing machine, shipping weight, 6,500 pounds.....	1,500.00	
	15 horsepower induction motor.....	225.00	\$ 1,771.00

6.	Main office and superintendent's office, 80×15, 1,500 cu. ft., at 15 cents.....	225.00	
	Assay office, 20×15 materials.....	2,000.00	
	Furniture, office.....	500.00	\$ 2,725.00
7.	Store house, 60×10, 600 cu. ft., at 15 cents.....	90.00	
8.	Powderhouse, 10 ft.×10 ft., brick, erected.....	100.00	
9.	Two water tanks, each holding 10,544 gallons, weight, each 3,000 pounds, each \$195.....	\$ 390.00	
	1,500 feet of 4-inch supply pipe from city reservoir, weight 10.60 per foot (15,900 pounds), at \$1.08 per foot.....	1,620.00	\$ 2,010.00
	Freight on all materials bought in Denver, about 80,000 pounds, at 55 cents.....	440.00	
	Total.....	\$17,339.44	

ELECTRIC INSTALLATION—SURFACE

One 53-horsepower induction motor for hoist; one 80-horsepower induction motor for development compressor; one 380-horsepower induction motor for compressor for final work; one 10-horsepower induction motor for machine shop; one 15-horsepower induction motor for timber mill.

INCANDESCENT LIGHTS

One 16-candlepower for every 100 square feet in all buildings, except offices. In offices, two 16 candlepower for every 100 square feet and localized near desks.

Hoist house, 6 and 6 localized.....	12
Blacksmith and machine shop, 8 and 6 localized.....	14
Electric station house.....	2
Timber yard and shed, 12 and 6 localized.....	18
Offices, 30 and 10 localized.....	40
Store house, 6.....	6
Powder house.....	1
Sorting house.....	10
	103

UNDERGROUND

One 150-horsepower induction motor for large pump

INCANDESCENT LIGHTS

At ore chutes.....	24
For two stations.....	4
In cross-cuts.....	12
For two loading stations.....	4
For shaft.....	60
For pump stations.....	4
	108
Total incandescent lights.....	211

Allowing 55 watts power for each 16-candlepower lamp energy consumed, 11.6 kilowatts; 1,100 feet No. 0 B. & S. three-conductor cable to carry current to pump, 177 pounds; 1,500 No. 0000 B. & S. three-conductor cable for lights, 900 pounds.

來 來

A Cast-Iron Water-Jacket

By E. C. Reeder, E. M.*

In smelting copper ores to matte in a water-jacketed blast furnace, there is always more or less trouble with the jackets burning. When making high-grade matter of 40 to 50 per cent. copper, usually the jackets most likely to give out are the tap-hole jackets or plates on the settler, which in most plants are made of cast iron with a cooling coil cast in them.

The Canadian Copper Co., Copper Cliff, Ontario, Can., smelts copper-nickel ores to a copper-nickel matte containing from 28 to 35 per cent. in combined Cu and Ni, the Cu and Ni being in the ratio of 3 to 5. This is without doubt the hottest and most corrosive matte made in a water-jacket blast furnace anywhere.

The furnaces at Copper Cliff measure 50 in. × 204 in. at the tuyeres and have a height of about 20 feet from tapping floor to charge floor. The smelting column ordinarily is about 10 feet deep and the furnaces are usually blown with about 30,000 cubic feet of free air per minute at a pressure of 50 ounces. The average capacity of each furnace under normal conditions is from 450 to 500 tons of charge per day. The ores in the charge average between 5 and 6 per cent. combined copper and nickel, and the result is a very heavy matte fall accompanied by large quantities of heavy iron slag, all very hot. About 8 per cent. coke is used on the charge.

* Chicago, Ill.

Some 6 years ago, when smelting first began at Copper Cliff, the furnaces were constructed with the steel-plate water-jackets and water-jacketed spouts. When the first furnace was blown in, as soon as the starting bar was pulled out of the breast jacket, there was an explosion when the hot matte touched the steel spout, and a series of explosions followed, lifting the spout from its place and hurling it 50 feet or more. Other spouts were tried, but until the scheme of building the spout of chrome brick was tried there was little success. The spouts are therefore now built of standard chrome brick, cooled with cast-iron plates containing pipe coils. The channel in these spouts lasts about a month, when the furnace is shut down for a few hours until the brick can be replaced. But spout troubles were as nothing compared with the time lost and trouble caused by holes burning in the furnace jackets. The hot matte would burn a hole through a 3/8-inch jacket sheet like a small boy pushing his thumb through a warm pat of butter. Of course when the matte struck the cooling water

of the jacket, the inevitable happened, with the result that the jacket, or may be several of them, would be found on the floor. It sometimes happened that a furnace would run for a month without losing a jacket, and often it might not be in blast more than an hour or so after replacing a jacket before it would be necessary to make a fresh start. The repair gang often was on duty 3 days at a stretch, as one furnace after another would go out. Under such conditions a large stock of spare jackets of all descriptions was required in order to keep two furnaces out of three in blast continuously. The difficulty was overcome by using cast-iron jackets for the lower tier containing the tuyeres instead of the plate

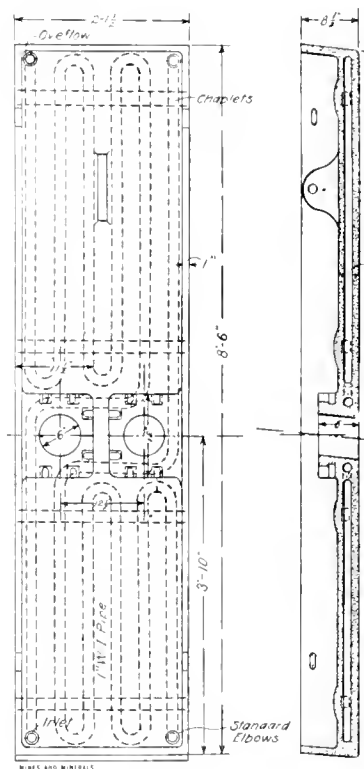

FIG. 1. WATER JACKET

jackets. The upper tier of jackets, which did not come in contact with the molten charge, continued to be of the ordinary plate construction.

The design of this cast-iron jacket with its cooling pipes is shown in Fig. 1. They are made in the company's foundry and it took a good deal of effort and care before a really first-class jacket was obtained. When in use, these jackets last indefinitely, as the matte seems to have no effect upon them, and when failure does take place, it is by cracking along the line of the chaplets which hold the pipes in place in the mold while casting. These chill the iron and make a weak spot. Some of the jackets have been in service for 9 months and were in good condition at the end of that time. The cooling pipes are blown out every day with compressed air to remove accumulations of sediment. No machine work is necessary on these castings outside of facing off the seats for the tuyere elbows.

When the jackets are scrapped they can be broken, remelted, and recast.

This style jacket, which has been applied to all the furnaces at the Copper Cliff plant, has now been in use over 3 years.

International Smelter at Tooele, Utah

Method of Sampling, Handling Ore by Conveyers, and
the Process of Roasting and Converting

By Leroy A. Palmer

The Tooele* smelter, the first plant built by the International Smelting and Refining Co., has been in successful operation since the late summer of 1910. From the start, operation has been attended by little difficulty; and the business of copper smelting being well under way, the company has announced its intention of building a lead smelter; and ground is being broken for this plant adjacent to the other. The site is 7 miles from Tooele Station on the San Pedro, Los Angeles & Salt Lake Railroad, which is 34 miles west of Salt Lake City. The plant and the railroad are connected by the Tooele Valley Railroad, operated by a subsidiary corporation of the smelting company.

The smelter site proper embraces 300 acres, but in order to preclude litigation over fume damage, options were secured on all the cultivated land within a radius of 4 miles. To secure an adequate water supply a number of these options were exercised so that the company owns outright about 2,000 acres of land. \$150,000 was spent in securing the land and options.

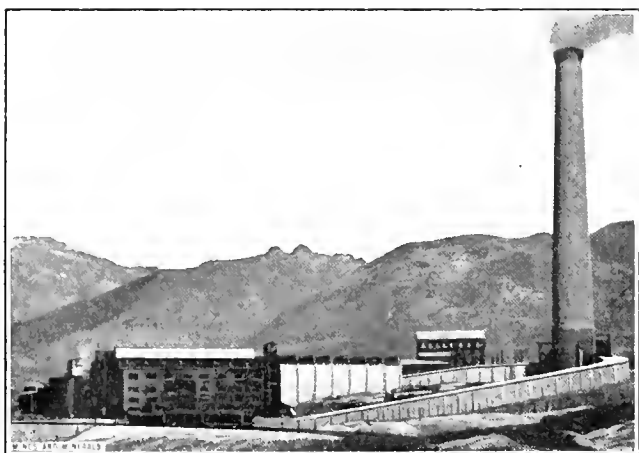

FIG. 1. TOOELE SMELTER

The plant is exceptionally well designed and favorably located, the ground having a slope such that gravity assists to a large degree in the handling of the product of one department to another. It embraces the usual equipment of a copper smelter designed to convert ore or concentrate into blister copper, with the exception of blast furnaces. A space has been reserved for these and it is the intention to equip the plant with them later.

Sampling Mill.—The plant is provided with spacious railroad yards, about 10 miles of track being included in the entire industrial system, with a double standard-gauge track running over the steel trestle to the ore bins. A 50-ton electric car handles the ore from the Utah Consolidated tramway bins, and the Tooele Valley Railroad delivers that which comes in by rail. The bins, which have a capacity of 10,000 tons, are built double and in two sections, the conveyer belts which feed the sampling mill running laterally between them. The rails of the tracks are supported on 15-inch I beams and the bins rest on 30-inch I's with 18-inch uprights on 10-foot centers tied across the top with 24-inch I's. The bottoms are sloping and lined with $\frac{1}{4}$ -inch iron. One set of bins is used for the storage of coal, ore that has been custom sampled, fine ore that is to be split shoveled, etc. These discharge through air-operated gates to cars run on the industrial system. The other set of double bins is used for the ore which is to be run through the sampling mill.

* Pronounced Too-il-la.

These bins discharge through hand-operated rack-and-pinion gates to a mechanical feeder, shown in Fig. 2, which runs on a 48-inch track over a 30-inch horizontal belt conveyer. The feeder consists of a hopper with a capacity of $\frac{1}{2}$ cubic yard above a belt of 20 iron panels, each 9 in. \times 24 in. \times 3 in. A 10-horsepower Westinghouse direct-current motor drives the panel belt which delivers a uniform feed to the conveyer which runs at the rate of 160 feet per minute. If desired, the feeder motor can be clutched into a gear and the feeder moved back and forth along the track to whichever bin it is desired to sample. The conveyer belt is controlled by a clutch whose lever is connected to the second floor of the mill by a wire rope so that the feed can be regulated at the crusher.

The horizontal conveyer discharges to one of the same width which runs at an angle of $11\frac{1}{2}$ degrees at a speed of 170 feet per minute and delivers to the second floor. The sampling mill is in two units throughout, each being driven by a 175-horsepower, 2,000-volt, Westinghouse induction motor. The building which occupies ground space of 40 ft. \times 84 ft. has a steel frame with corrugated iron sheathing and reinforced concrete floors. On the second floor the inclined conveyer discharges to a hopper which feeds over a shaking screen with 2-inch punched holes to a 12" \times 24" Blake crusher making 198 revolutions per minute and set to break to 2 inches. The screen undersize drops to a short inclined 20-inch conveyer and discharges with the crusher product to a steel-housed elevator. This elevator is gear-driven with a speed of 350 feet per minute, having a 20-inch belt with cups 10 in. \times 10 in. \times 18 in., spaced at intervals of 2 feet. It discharges at the top of the mill where a sample is cut out and chuted to a shaking feeder which discharges to a 20" \times 10" Blake crusher set to 1 inch and making 192 revolutions per minute. Passing this a second cut is made and sent to a set of 48" \times 12" Anaconda rolls set to $\frac{1}{4}$ inch, making 80 revolutions per minute, passing which a third cut is made and sent to a set of 26" \times 15" rolls, after which the final cut is made and sent to the sample safe. The sample is split shoveled and finished in a laboratory crusher and a Braun pulverizer. Brunton samplers are used and a $\frac{1}{2}$ cut made after each crushing so that the final sample represents $\frac{1}{256}$ of the whole.

As the equipment of the plant does not include blast furnaces, it is necessary that all ore shall be crushed to such size as will enable the reverberatories to smelt it readily, and a portion of the sampling mill is given up to the crushing apparatus. The reject of the first sample goes to a 4' \times 14' trommel, with a frame of heavy angle irons and a covering of three $\frac{1}{2}$ -inch manganese steel plates, which makes 16 revolutions per minute. The first two plates have $\frac{3}{4}$ -inch punched holes and the third $1\frac{1}{4}$ -inch holes. The oversize of this trommel goes by a divided chute to two 15" \times 9" Blake crushers set to 1 inch and making 310 revolutions per minute. The crusher product, with the undersize from both screens of the trommel, goes to a similar trommel with $\frac{3}{8}$ -inch openings. The oversize of this trommel goes to two sets of 48" \times 12" Anaconda rolls making 84 revolutions per minute which discharge with the undersize to a short 20-inch conveyer to the boot of an elevator which dumps to the fine ore conveyer. The rejects of the different samples after the first, are chuted into this system at the point necessary to give them the proper crushing. When the blast furnaces are installed this crushing will not be necessary, and the coarse will be chuted to a belt running parallel to the fine ore conveyer, and that which is rejected at a point in the system too low to run to this belt by gravity will go to a third elevator beside the second and be elevated to it. The second and third elevators are uniform with the first in equipment and speed. Rolls, trommels, and elevators are steel housed to prevent the escape of dust. A belt elevator is provided to convey the men from one floor to another.

Conveying System.—The coarse and fine ore conveyers run parallel and discharge to two 20-inch rubber belts, also parallel but running in opposite directions. The coarse ore goes to the

blast furnace bins which are of steel construction and have a capacity of 3,500 tons. The bin is double, discharging on either side through air-operated gates to cars on the industrial system. The fine ore bins are double, 180 feet long, with a capacity of 5,700 tons. The fine ore conveyer, 300 feet long, moves at a speed of 375 feet per minute, and discharges by means of a tripper to any desired point on either side of the bin, over a 1-inch grizzly carried on the discharge hopper.

On either side of the roaster bin the ore is fed mechanically to a 20-inch horizontal conveyer that discharges to a third conveyer that runs at right angles. The first conveyer has a 10-horsepower motor, and the third, which is much shorter, a 5-horsepower. The latter conveyer is about 6 feet below the surface of the ground, and above it is a hopper in one of the tracks of the industrial system. By means of this hopper the ore that has not been run through the sampling mill is conveyed to the roasters. The third conveyer discharges to a fourth which runs at right angles to it but inclined at an angle of 14 degrees. This fourth conveyer, which is 280 feet long and has a speed of 340 feet per minute, carries the ore to the top floor of the roaster building, passing on its way over a Blake-Dennison continuous weighing machine by which the feed is automatically weighed and the weight recorded. The inclined conveyer is provided with a tripper by which it dumps to any of the four belts running over the roasters on each of which is a tripper to discharge the feed to the particular roaster it is desired to supply. Each of these belts and the inclined belt have a 10-horsepower motor. It will be noted that from the time the ore leaves the bins at the sampler until it is dumped into the roasters it is handled entirely by belts, with the exception of the elevators in the mill. There being no loading into cars with the attendant switching, manual labor is reduced to a minimum, a continuous feed is secured, and only 35 horsepower is required to run the conveying system.

The roasting plant contains thirty-two 16-foot MacDougall roasters arranged in four rows in two steel-frame buildings, each 64 ft. \times 162 ft. Each roaster has six hearths and the arm makes a complete revolution in 55 seconds, this speed requiring about 2 hours to work the charge through the roaster. The capacity of a single roaster is about 45 tons per day. The ore of the Utah Consolidated, the largest individual shipper to the plant, carries from 26 to 30 per cent. sulphur, and this is given a roast which eliminates about 80 per cent., bringing the calcine down to 5-7 per cent. sulphur. Silicious ores received from the Tintic district are discharged to a spout alongside the roaster and conveyed by it to the fifth hearth where they mix with the calcine. The mixture is in the proportion of 70 tons of silicious ore to 400-500 tons of base, so that the resultant calcine contains about 5 per cent. sulphur. In those roasters treating the Utah Consolidated ore, water is used on the third, fifth, and sixth arms, but in those treating the fine concentrates of the South Utah, which run 24 per cent. sulphur, no water is used at all. The introduction of the silicious ore on the fifth hearth tends to cool the lower portion of the furnace, so that on the furnaces used for this purpose a brick firebox has been built on each side of the third hearth and these are fired with coal to bring the heat to the proper point. One roaster is used to drive off moisture from the silicious ore that is used for converter linings. Each unit of 16 roasters is driven by a 30-horsepower motor. The hot water that has been through the roaster arm is piped to the cooling tower and the cool water is pumped to the circulating tank in the top of the roaster building by a centrifugal pump belted to a 30-horsepower motor.

The roaster buildings are provided with brick dust chambers 162 ft. \times 14 ft. \times 12 ft., which receive the fumes from each roaster through two 36-inch elbows. These smaller dust chambers discharge to the main dust chamber, which is 120 ft. \times 140 ft. \times 40 ft., terminating in a flue 255 ft. \times 16 ft. \times 16 ft., which enters one side of the stack. The smaller dust chambers are provided with 14' \times 2' steel hoppers, 8 feet apart, and the larger with

6-foot steel hoppers running across, with 12-inch gates. The hoppers are above tracks on the industrial system by means of which the dust cars are brought directly beneath. An analysis of calcine from Utah Consolidated ore shows: *Cu*, 2.30 per cent., *SiO₂*, 26.7 per cent., *FeO*, 49 per cent., *CaO*, 3.6 per cent.

Each MacDougall furnace discharges to two hoppers beneath, from which the calcine cars, holding 7,300 pounds, are loaded and hauled to the reverberatory charge building, which is 66 ft. \times 280 ft. The furnace building proper, is 82 ft. \times 326 ft., adjoining which is the boiler house, 36 ft. \times 326 ft. At one end of this building space has been reserved for two blast furnaces. The reverberatory furnaces are of the Anaconda type, five in number, each 19 ft. \times 102 ft., with a minimum rating of 300 tons per day. Each side of the furnace is provided with eight doors and the space between them is braced with 6-inch I-beam buckstaves on 12-inch centers. The tops are tied both crosswise and lengthwise with heavy steel rods so as to give a strong structure. Calcine is charged through two hoppers, one with two and the other with three discharge openings, and coal through a single hopper with five openings. The coal is brought in from the stock pile by the electric cars or can be run in in the large railway cars from the Tooele Valley tracks. As the ashes are raked out they fall into ash cars which are hauled to the dump. So far no attempt has been made to

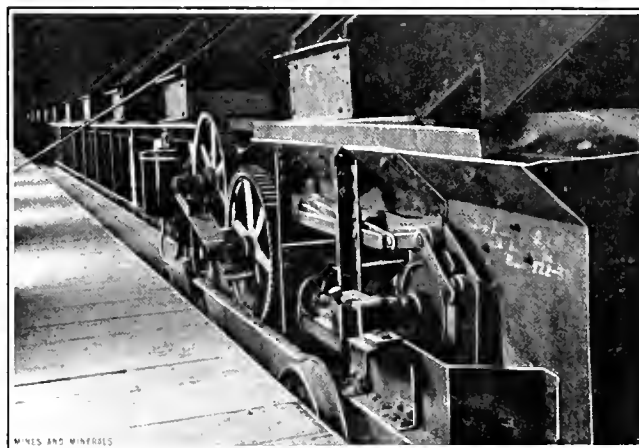

FIG. 2. MECHANICAL FEEDER AT SAMPLE BINS

recover the coal in the ash. Back of four of the furnaces are 750-horsepower Stirling water-tube boilers utilizing the heat that would otherwise be wasted in the flue. Each of these boilers generates 600 horsepower in steam at 150 pounds pressure and is set with a brick by-pass, so that when it is necessary to clean a boiler it can be cut out and the gases discharged into the flue.

Twelve tons of calcine are dumped to a charge, and twice a shift. When the slag rises three or four inches above the skimming plate in the furnace it is skimmed through a steel launder to slag cars in the slag tunnel in which is a standard gauge track on steel ties. These cars have a volume of 225 cubic feet and a capacity of 20 tons of slag, and each is provided with a motor with rack-and-pinion gearing, so that the car may be dumped from the cab of the locomotive. The cars are hauled to the dump by a Baldwin-Westinghouse locomotive fitted with two 60-horsepower motors, automatic couplings and air brakes. An average reverberatory slag will analyze: *Cu*, .35 per cent.; *SiO₂*, 42 to 45 per cent.; *FeO*, 42 to 45 per cent.; *CaO*, 4.5 per cent.

The matte produced in the furnace is tapped through a copper tap-hole plate to steel launders in which it runs to the converter plant. The launder discharges to a steel spout on ball bearings, so that the matte can be run direct to a converter or to a ladle and be transferred to some other converter in the

line. The launders from each side of adjacent furnaces cross each other running to different converters, so that one side of a furnace can be tapped to either of two converters without using a ladle. An average matte assays: *Cu*, 28 to 31 per cent.; *Fe*, 40 per cent.; *S*, 25 per cent.

The flue that serves the reverberatories is 20 ft.×18 ft.×1,360 ft. terminating at the stack on the side opposite to that at which the reverberatory flue enters. It is provided with clean-out doors and both flues have heavy counterweighted steel dampers. The stack is 350 feet high with an inside diameter at the base of 36½ feet and the top of 25 feet; 1,750,000 brick were used in its construction. Natural draft alone is used and averages 1.8 inch.

The converter building, Fig. 4, is 65 ft.×408 ft., adjoins the reverberatory building, and next to it is the casting shed, 52 ft.×255 ft. The size of the converter building affords ample room for the handling of ladles and converters and does not present the crowded appearance so often found in this branch of the operations. There are five stands for Power and Mining Machinery Co. Lehigh converters, 96 in.×150 in. in size, with sixteen 1-inch tuyeres. Each converter is controlled by a 40-horsepower motor. The slag is poured to ladles that are picked up by a crane and set on a platform convenient to a smaller cross-travel crane which carries them to the reverberatory building. Between two pairs of the furnaces are pouring stands with launders running each way to a side door in the furnace. When converter slag is to be poured a spout is attached to the launder, so that the slag discharges well within the furnace where the heat is high, so it does not have a chance to chill and solidify around the doors. The slag assays:

SiO₂, 29 per cent.; *FeO*, 58 per cent.

The ladles to which the blister is poured are set convenient to a crane by which they are picked up and carried to the casting floor. Here the blister copper containing 98-99 per cent. copper, is cast into ingots weighing 250 pounds, and these are shipped to the United Metals Refining Co., at Raritan, N. J., for refining. At present the converters are operated only one shift. When one is closed down it is sealed, so as to retain as much of the heat as possible, and by this means it is found that no inconvenience results from the interrupted operation.

The converter hoods are raised and lowered by small motors. The fumes go to a steel hopper-bottomed flue, 248 feet long, 8 feet wide, and 12 feet deep, with hoppers terminating in 12-inch discharge pipes 4 feet apart. This discharges to a flue 181 feet long with a cross-sectional area of 132 feet, which connects with the flue which serves the reverberatory furnaces. The converter plant is equipped with five Morgan-Gardner electric cranes, one 60-ton for handling converters, one 30-ton for handling ladles on the converter floor, one 30-ton for handling ladles on the casting floor, and two 12½-ton for handling slag.

The power house is built of brick over a steel frame, 52 ft.×240 ft., widening at the middle by a bay on each side to

112 feet. Steam is carried in two 12-inch lines from the waste-heat boilers and from one 250-horsepower hand-fired boiler. There are three of these hand-fired boilers, but only one is kept under steam, the others being held for an emergency. They discharge into the main flue, but are so connected that they can discharge through a steel stack, 15 ft.×40 ft., and when this is used they are supplied with induced draft from a 12-foot Sturtevant fan direct-connected to a vertical 8"×13" piston valve engine. In the basement of the power house the feed-water is filtered through coke and heated in an open heater by using the exhaust from the pumps and the discharge from the steam traps. It is forced into the boilers by a Knowles twin-tandem plunger pump, 8 in.×12 in.×6½ in.×10 in., with a capacity of 332 gallons per minute. A Worthington, outside, center-packed duplex, 12 in.×7 in.×10 in., with a capacity of 346 gallons per minute, is installed as an auxiliary. For fire protection, a Worthington duplex plunger pump, 16 in.×9 in.×12 in., with a capacity of 750 gallons per minute, forces water to two 44,000-gallon tanks placed at a height that gives good pressure at any part of the works.

The following engine equipment has been installed:

One Nordberg tandem-compound Corliss engine, 16 in.×30 in.×36 in., 350 horsepower, making 120 revolutions per minute, direct-connected to a 250-kilowatt Westinghouse direct-current generator, generating at 550 volts, 455 amperes.

One Nordberg tandem-compound Corliss engine, 16 in.×32 in.×36 in., 350-horsepower, making 120 revolutions per minute, direct-connected to a generator the duplicate of the above. These generators furnish the direct-current used in the industrial system.

Two Union Iron Works triple-expansion marine engines, 18 in.×26 in.×40 in.×24 in., 1,000 horse-

power, 180 revolutions per minute, direct-connected to 750 kilowatt Westinghouse alternating-current generators generating at 2,200 volts, 455 amperes, three phase, 60 cycles. These generators supply current for the various induction motors used around the plant.

One Nordberg cross-compound Corliss engine, 15 in.×30 in.×42 in., 350 horsepower, making 85 revolutions per minute, tandem connected to 36-inch duplex air cylinders with a capacity of 9,800 cubic feet of free air per minute.

One Rarig cross-compound Corliss engine, 26 in.×52 in.×48 in., 600 horsepower, making 40 revolutions per minute, connected to 52-inch duplex air cylinders with a capacity of 8,700 cubic feet of free air per minute. These blowing engines work to 15 pounds of air for the converters.

One Laidlaw-Dunn-Gordon cross-compound Corliss engine, 13½ in.×26 in.×36 in., tandem-connected to two-stage air compressor, 26 in.×15 in., making 50 revolutions per minute, with a capacity of 1,550 cubic feet of free air. This compressor works to 90 pounds, supplying air for the forges, sampling mill, etc.

One Ingersoll-Rand two-stage compressor, 26½ in.×15½ in.

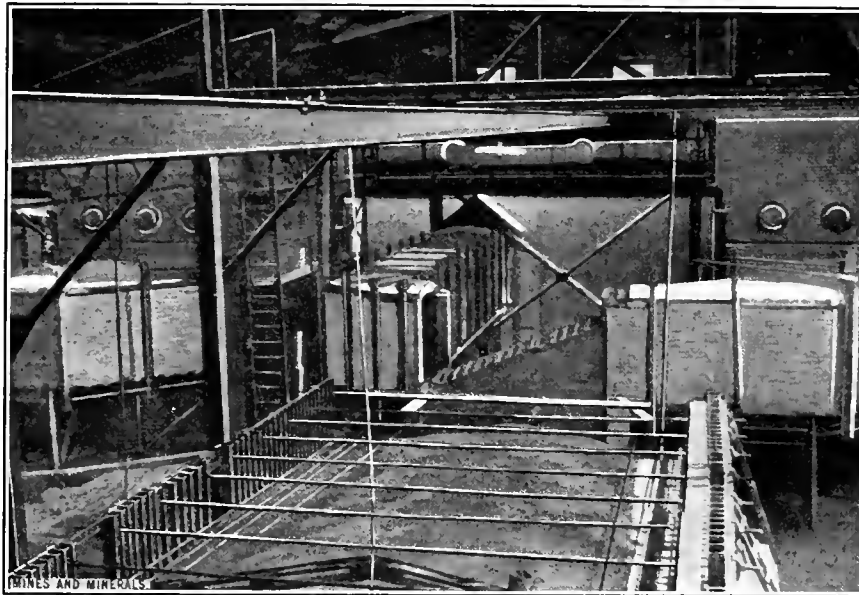

FIG. 3. TOP OF REVERBERATORY, SHOWING BRACING, WASTE HEAT BOILER, AND BY-PASS

× 8 in., with a capacity of 2,000 cubic feet of free air, belted to a 175-horsepower, 2,080-volt Westinghouse induction motor. This is held as an auxiliary to the steam-driven compressor. The air leaves the high-pressure cylinders at a temperature of about 140° F. and, as the mill and blacksmith shop are some distance away, the entrained moisture caused some trouble by precipitating along the lines. To obviate this the high air is passed through an intercooler before leaving the power house and subjected to a cooling that removes a sufficient amount of the moisture, without lowering the pressure to a point that makes an appreciable decrease in the efficiency.

One Westinghouse generator set, consisting of a 290 horsepower, 2,200-volt induction motor direct-connected to a 200-kilowatt, 550-volt direct-current generator. With the present smelting equipment one of the marine engines alone generates an excess of alternating current, so this generator set is used to supply part of the current for the industrial system, and one of the steam generator units is not operated.

Two exciter sets. One of these consists of a 12"×12" Skinner slide-valve engine making 300 revolutions, direct-connected to a 50-kilowatt direct-current generator and the other of a 75-horsepower 2,200-volt Westinghouse induction motor direct-connected to a similar generator.

All the engines are run condensing. The marine engines each have their own condensers connected to 12"×18" circulating

26,000 yards of plain and reinforced concrete and 200,000 yards of excavation, most of it by steam shovel, was required.

It will be noted from the description that manual labor has been reduced to a minimum, especially in the handling of products. The operative force is less than 300 men. From the start, operation has been attended by no difficulty due to design. The various foremen have been permitted to try such minor changes in operative methods as seemed advisable to them, and a system excellent in detail has been worked out. The chief handicap has been a shortage of ore. The contract with the Utah Consolidated called for a maximum daily tonnage of 1,200 tons and it was expected that an amount approximating this would be shipped and that, with ores from other sources, the five reverberatories would be working to full capacity from the start. The amount from this source has fallen below this, so that for a considerable portion of the time only three of the furnaces are in operation. Not working the full complement of furnaces for which the flues and stack were designed has tended to decrease the draft and the ratio of coal to ore, 1 to 2½, is not as low as was expected. As more contracts for ore are being made, it is hoped to overcome this difficulty.

The water supply is from Pine Creek. It is brought to the plant from a dam in the cañon, a distance of 5,000 feet, in a 12-inch pipe line, and distributed from a 50,000-gallon stand-pipe. A good supply of lime rock for fluxing purposes can be obtained from this cañon. For the reasons given in the first part of this article, no trouble is expected with the surrounding ranchers, but as a matter of precaution the stock and vegetation of the surrounding country was examined, before operations were commenced, by veterinarians and botanists, and careful notes, which, if necessary, can be used later for comparison, were collected. A hospital is in operation at Tooele City and at the plant is an emergency hospital under charge of a competent trained nurse who is always on duty. A gasoline car is held at the disposal of this department for quick transportation to the general hospital of any cases requiring immediate surgical attention. The plant has about the same haul from most of the camps as the Garfield smelter, with which it comes in competition, but with the Utah Metal Tunnel in operation will be about 17 miles nearer Bingham.

The writer is indebted to the many employes of the smelter from whom he sought information and to E. P. Mathewson, General Manager, H. N. Thomson, Superintendent, and W. G. Walton, Chief Engineer of the power plant.



FIG. 4. CONVERTER BUILDING

and air pumps. The latter give a vacuum of 18 inches in an altitude where 22 inches is absolute. The engines on the generator units are connected to a Deane condenser with 16"×24" steam cylinder and 24-inch water cylinder, giving a vacuum of 20 inches. The blowing engines and steam-driven compressor are connected to a Westinghouse-LeBlanc condenser, driven by a 95-horsepower induction motor. All of the condensers pump to a natural draft cooling tower, 140 feet long, 20 feet wide, and 49 feet high. The power-house is equipped with a 15-ton electric crane.

The alternating current which is generated at 2,200 volts is transmitted at this voltage and stepped down by small transformers placed on the line at various points where it is desired to use the lower voltage. It is intended later to supply current to the Utah Consolidated mine and tram, and for this purpose three 200 kva. transformers stepping up from 2,200 to 11,500 volts have been installed but are not yet in use.

In the construction of the smelter a great deal of material from the Highland Boy smelter, formerly the property of the Utah Consolidated, was used. The greater portion of the power-house equipment came from this plant and from Anaconda, Mont. The Highland Boy furnished 3,000 of the 9,900 tons of structural steel and 20 of the 32 MacDougall roasters. The old steel stack was also cut up and used. In the construction,

來 來

Society Meetings

The Lake Superior Mining Institute will hold its sixteenth annual meeting, August 22, 23, and 24, on the Menominee Range. At the meeting, held last year, a committee was appointed to prepare papers on the subject of Mining Methods on the Menominee Range. There will be papers on Efficiency, Uniform Mining Laws, and Safety Appliances.

The American Mining Congress will hold its fourteenth annual session in Chicago during the week beginning September 25. President Taft and the Secretary of the Interior, Walter L. Fisher, have promised to attend this convention.

The Nanticoke District Mining Institute of Pennsylvania, which was organized October 18, 1910, with John T. Thomas, president; William H. Morgan, vice-president; John D. Evans, treasurer; D. M. Hopkins, secretary; and F. H. Kohlbraker, John Kelly, David Samuel, J. N. Turner, Joseph J. Walsh, John E. Thomas, George Hopper, Frank Kettle, William T. Jones, Samuel Saville, C. K. Gloman, and C. L. Fay, directors, held its first regular meeting November, 5, 1910. The first annual dinner of the Institute was recently held in the Broadway Hall, at Nanticoke. It was an enjoyable affair in which coal company officials mingled with the members of the Institute.

Gold Dredging in Foreign Countries

Difficult Conditions Met With in Africa. Methods Used in New Zealand

When a river flows over land the top soil is washed away, leaving the gold-bearing gravel as river bed. It is from this residue that gold is obtained in South and West Africa by floating dredges. The gold coast of West Africa is a typical tropical dredging country. From the coast inward, stretches a swampy belt of dense forest. Most of the sluggish rivers which flow through this country to the sea owe their origin to the highlands of the hinterland, and are fed by the periodical heavy rains that make life a burden all along the coast. These rivers must at various points have cut through or alongside of the gold-bearing reefs of Ashanti, and in their beds are to be found large quantities of alluvial gold. During the dry season many of them are but small, shallow streams, but the Offin River has been known to rise as much as 15 feet in a single night when the wet season begins. The banks of these rivers are covered with the densest forest (bush), and from their surface arises the miasma, probably microbes, which has had the effect of bringing West Africa into such ill repute as a fever-stricken country. Except in the case of the big navigable rivers, the waterways of West Africa are used solely by native fishermen. No good roads exist, and as a result, jungle tracks have to be cut and maintained by the mining companies. Running as they do through swampy country, these roads are for six months of the year almost impassable, and all the time require constant cutting.

Conditions existing in a much cooler country like New Zealand are, of course, very different. There the country is open and the roads are, taken as a whole, good. Coal is used for fuel, as much as 100,000 tons in a year, while in West Africa there is enough lumber along the banks of most of the rivers to keep the dredges going for 50 years.

It may be said that steam launches or tugs will do the transport work satisfactorily in West Africa, but however

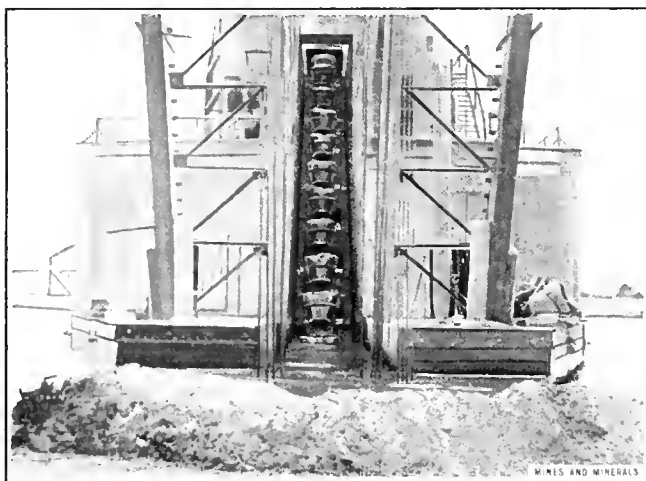

FIG 1 BUCKET DREDGE

careful the dredgemaster may be in the disposition of tailings, the scattered heaps of worked gravel left behind by a dredge make navigation very hard in the dry season, while in the wet season it is almost impossible to steam against the swift currents.

In appearance, West African gold dredges are very much like the dredges which work in harbors and on river bars, with the difference that gold-saving appliances in the form of sluice tables, revolving screens and other apparatuses are built into their after end. They do not propel themselves, but are moved

and steered by means of steel head, side, and stern lines. Each dredge is fitted with a steam winch, with the aid of which and the lines, these latter being tied to big trees, it can haul itself forward or move from side to side. A string of buckets (dippers), each of from 4 to 7 cubic feet capacity, is driven by a main engine, and can dig to a depth of as much as 40 feet, while the pumps suck from the river and throw a constant stream of

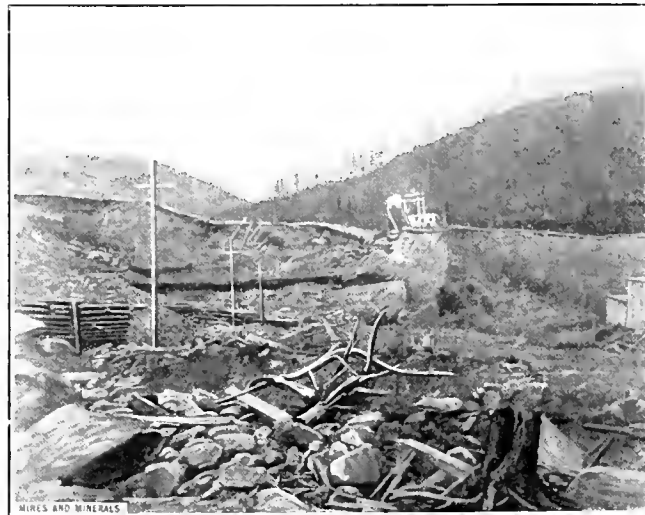

FIG. 2. DREDGING GROUND AND DREDGE

water on to the gold-saving tables, into which are emptied the contents of the buckets as they come up. These tables are about 60 feet long, and are laid at a suitable angle. They are paved with steel riffles and cocoanut matting, like those used in our own country, the gold being interrupted by the former while it is in transit, and held by the latter. In ordinary circumstances these riffles and mats are taken up and washed about once a week. Some dredges are fitted with revolving perforated screens, into which the gravel is tipped and broken up, the gold falling through the perforations on to the tables, which in this case are placed immediately below the screen.

This short account of the process of gold getting is, of course, incomplete, and does not attempt to describe the problems with which the mining engineer is confronted in such matters as slope of tables and quantity of water required.

Mention has already been made of New Zealand as a dredging ground, and there is little doubt that that country has pioneered the industry. In the sixties the now out-of-date spoon dredges were at work there, and since then the apparatus has steadily improved, although it is not yet on a par with the most modern American machinery. The "Earnsclough" No. 3, now working in New Zealand, has buckets each with a capacity of 7 cubic feet. The pontoons are 130 feet in length, and the width is 30 feet. The dredge draws 7 feet of water, dredges to a depth of over 50 feet, and by means of an elevator, with which nearly all modern dredges in New Zealand are fitted, stacks the tailings to a height of over 70 feet. In New Zealand about 250 dredges are working at the present time, and about 2,000 men are directly employed in the business of dredging for gold, to say nothing of such supernumerary dependants, as coal carriers, dredge builders and repairers. When it is mentioned that a modern dredge costs (in New Zealand) from \$40,000 to \$75,000, an idea will be given of the importance of this branch of gold-mining.

Before a dredging claim is definitely taken up, there are many things to be done, and considerable expense to be incurred in foreign countries, much the same as at home. When the existence of paying gold has been determined, a systematic prospect should be made. By means of such devices as the percussive drill, a series of bore holes is usually sunk in the

adjoining river bank. By these bore holes are discovered the depth of "overburden," as the top soil is called, the depth of gravel below the overburden, its richness—ascertained by panning the earth thrown up by a drill—and the average depth at which bed rock is met. Rich patches or flats have probably formed along the bank which will give good results, yet alluvial gold is such an elusive quantity that a dredge which shaves the bank in order to prospect it while working a river bed will often miss the rich streak that exists only a few feet inland. In tropical countries there is also a considerable amount of clearing to be done, as the jungle grows in great profusion right down to and overlapping the water's edge.

While actually working, the difficulties that are met with are sometimes enough to take all the ambition out of a conscientious dredgemaster. He has always to be on the lookout for hidden trunks of trees, huge logs, boulders, and other obstructions which, if dredged carelessly, would break his bucket ladder and probably put his dredge out of commission for some time. Again, there is always a great strain upon machinery which works a stable object, but which has not itself got a stable foundation. Bucket links are liable to give way, and drop out; steel bushes wear with extraordinary rapidity, and the engines themselves are always being subjected to sudden jerks and strains.

In New Zealand, a crew of eight white men can work a dredge, and the ratio of accidents is small; but in a country like West Africa, where costs of working are high and the white crew as a rule consists of only four men—a dredgemaster and three winchmen—natives have to be relied upon as greasers and firemen, with the result that, where the white man is unable to supervise everything, the bearings often become heated, the boilers have either too much or too little steam in them, and expensive accidents are not uncommon.

One of the greatest problems with which the dredging industry has up to now been confronted in New Zealand is involved in the dredging of agricultural land. In our own country this problem does not trouble us at all, and is not likely to do so for the next half century or more. Some authorities consider that it is practically impossible to reposit top soil on top of dredged gravel in sufficient thickness to make the land available for agricultural purposes almost immediately. At present all tested methods seem impracticable. Nature forms, inscrutably and slowly, and by means of many contributory conditions a combination of soils which we call "fertile," and if we violently upset and destroy that combination, nature's ideals cannot be attained again in a few weeks or months. A New Zealand firm, named George, of Naikaka, has used a contrivance by which the top soil is separated from the gravel and, after passing through a long extra chute, is redeposited on top of the gravel. This plan has its advantages, but some time must, nevertheless, elapse before the land regains anything like its original value; and although in our country the mineral wealth may be much greater than the agricultural value of the land in which gold is found, in New Zealand the permanent wealth, represented by fertile agricultural land, will always be greater and more important than the value of any mineral which may be extracted from it.

柔 柔

Cobalt Silver Veins

Why should the calcite veins of the Cobalt, Ontario, silver district continue with depth is a question which has been asked by more than one person. The answer involves a comparison with known ore deposits in similar rocks, and simple deductive reasoning. The veins are in Huronian rocks, which were formed at a time when organic matter was very scarce, if there was any at all; and when veins occur in such rocks they are nearly perpendicular, because of the rocks being hard, and naturally the earth movements that caused such fissures must have

originated at great depths. It is evident, from the lakes and other known geological signs, that the present rocks were covered by rocks of a later period, which in all probability were Cambrian limestones. It is evident that the diabase eruptions occurred while the Cambrian rocks were in place. This would also indicate that the fissures, originated at great depth and that the rocks must have hardened previous to the fissuring, otherwise there is no way of accounting for the calcite in these veins, because it must have been deposited prior to the glacial erosion which followed long after the diabase was erupted. The diabase in the immediate vicinity of the Cobalt silver-calcite veins is a deep-seated aqueo-igneous magma which, when ejected, undoubtedly was accompanied by magmatic solutions that in all probability carried silver. Bearing in mind that this rock material carries no carbonates, it seems plausible to assume that the ejection of the diabase occurred after the Cambrian rocks had formed and prior to their erosion. If this hypothetical reasoning is correct then the ascending waters carried the metallic solutions and the descending waters the carbonated solutions, which, on meeting, caused the precipitation of silver and calcium carbonate, or calcite. There is, of course, no method of determining to what extent the present Cobalt veins have been shortened by erosion, but it would appear from their age that they should go to considerable depth.

Attention is directed to the fact that where metals are found carbon in some form is also found. Gold is found in the metallic state that is practically free from impurities in only those positions where carbon in solutions, either in place or descending from the surface, has been able to reach it; copper is another example, so also may be included silver.

柔 柔

National First-Aid Field Day

The Federal Bureau of Mines has decided to hold a first-aid meet at Pittsburg, Pa., in the Fall. First-aid teams will be sent to participate in the events by the various mining companies in the North, East, South, and West. While there will be no competitive events between the different teams, there will be exhibitions of their skill in bringing injured from the mines and furnishing first aid to the injured. The Bureau of Mines will have the cooperation of the Northwestern Improvement Co., Colorado Fuel and Iron Co., Tennessee Coal and Iron Co., the large anthracite mining companies, the Pittsburg Coal Operators' Association, and the American Red Cross. It is expected that between 20,000 and 30,000 miners will attend, and that there will be a parade, as the United Mine Workers are interested in the event and have signified their willingness to assist. The members of each team taking part in the events will be awarded a medal and each miner in the parade will be given a badge as a memento of the occasion. President Taft and Secretary of the Interior Fisher have promised to be present.

In addition to the first-aid teams, the miners will witness gas and coal-dust explosions in miniature, which will be staged in the great explosive gallery of the Bureau of Mines. In Arsenal Park there will also be a temporary gallery that will resemble a coal mine. This will be placed at the bottom of a natural amphitheater, giving a clear view to thousands. There will be a gas explosion in this play mine, miners will be entombed, and some of the Government Rescue Corps in oxygen helmets and rescue apparatus will enter and save them.

A number of spectacular events illustrating the danger from roof falls, blown-out shots, misfires, accidents due to cars and electric currents, carrying the injured after first-aid treatment over roof falls, over loaded cars in a narrow passage and placing them in an ambulance. At this writing it has not been definitely decided whether the exercises will be held in the Pittsburg base-ball grounds or in the Arsenal grounds. The former would seem preferable if it could be obtained as it offers better observation facilities.

The Ely Mining District, Nevada

Location and Railroads. Company Combinations. Method of Mining and Handling the Ores

By Perciv' E. Barbour*

Ely is located in White Pine County about 140 miles south of the main line of the Southern Pacific Railroad and about 30 miles east of the Nevada-Utah state line. Connecting Ely with Cobre on the Southern Pacific, is the Nevada Northern Railroad running in almost a straight line through Steptoe Valley, which is broad and flat and bordered on both sides by parallel mountain ranges. A standard Pullman sleeper on the regular daily train each way affords comfortable and convenient traveling. The trip from Ely to Salt Lake City requires about 11 hours. The Nevada Northern Railroad is owned exclusively by the Nevada Consolidated Copper Co.

Ely and its suburban towns of various names cause much confusion to one who has never visited the district. En route from Cobre over the Nevada Northern, the town of McGill, where is located the concentrator and smelter, is passed on the opposite side of the valley, about 14 miles from Ely. At a small station, McGill Junction, a couple of miles farther on, connection is made with a spur running to McGill. At the Junction is a settlement called Smeltonville which contains some of the overflow population from McGill. Just before Ely is reached is the town of East Ely, a more recent growth than Ely, with more space to grow and more pretentious buildings and streets and the location of the main offices of the Nevada Northern Railroad. Ely is situated in a slight hollow at the very mouth of Robinson cañon, and is the business center of the whole district, and has ample and very satisfactory hotel accommodations. The streets are wide and graded, the sidewalks are cement and there are costly buildings, some having cost from \$80,000 to \$100,000.

The population of the entire Ely district is between 8,000 and 10,000. The monthly pay roll of the district amounts to about \$300,000. Ely has two national banks, the usual quota of saloons, a red-light district shut off from the town by a high board fence, and some unusually good retail stores.

Ely, as a mining camp, has been known for over 40 years. In the early 60's there was a silver excitement in Hamilton, some 50 miles away. Many prospectors drifted from there into Robinson cañon in search of gold and silver. Considerable low-grade gold ore was found and cyaniding was subsequently applied to the treatment of them but with poor success owing to the considerable amounts of copper contained. As late as 1902 the Chainman mine erected a cyanide mill and added another failure to those of the past 30 years. Up to that time Ely was considered a gold camp. The low-grade copper ores were discovered in the meantime, although of course their enormous extent was not realized until within the last 10 years. Bradley, Requa, and McKenzie, developed the properties which were finally combined into the Nevada Consolidated. They put up an experimental mill and demonstrated the commercial feasibility of concentrating this very low-grade sulphide ore. So carefully were their experiments carried out that the 8,000-ton concentrator at McGill now uses practically the same flow sheet. In 1904, J. Parke Channing made his classic report on these properties and their capabilities. The Guggenheims then bought a stock control and the active development of this now famous low-grade porphyry copper camp was begun.

The present mining activity is up Robinson cañon, about 7 miles from the town of Ely. Frequent passenger trains from Ely to Veteran give very good accommodations for all interests. Up the cañon about 3 miles is Lane City with two old mills, both now idle. Just beyond Lane is the relic of the old Keystone smelter with its old-style rotary drier and elephant boiler and

*Consulting Mining Engineer, Tecoma, Nev.

hot-blast water-jacket furnace, mute evidence of earlier struggles. Farther along is Junction City, a name rather than a community, but Star Pointer, the next station, is the location of the Star Pointer shaft, with its fine steel head-frame, which is to be the main outlet for the ores of the Ruth mine and the deep mining of the Nevada Consolidated on the eastern portion of its estate. A mile to the north is Copper Flat, the scene of the Nevada Consolidated steam-shovel operations, and the center of the present greatest activity in the camp. Beyond in the broad flat is Rieptown, a quiet sunny residence town for miners, removed from the dirt and bustle of the work. A short distance farther west is Kimberly, the town of the Giroux company with its old smelter and mill, and a mile farther at the terminus of this railroad is the town of Veteran and the Veteran shaft of the Cumberland-Ely mine.

Since early in the fall of 1909 the Ely district has witnessed increasing activity and increasingly important developments. In August, 1909, the Cumberland-Ely mine was forced to suspend operations due to a miners' strike. Four hundred idle miners were thrown upon the district but were almost immediately absorbed by the other operating properties and no trouble ensued. The Cumberland-Ely owned a two-fifths interest in the concentrator and smelter at McGill. This shut-down allowed the Nevada Consolidated, the coowners of the plant, to greatly increase its output and shortly thereafter it absorbed the Cumberland-Ely property by an exchange of shares on the basis of $3\frac{1}{4}$ shares of the latter for one of the former. Under the new ownership the Cumberland-Ely has never been reopened. Some underground development work has been continued but the large tonnage already blocked out will await additional reduction facilities at the McGill plants. The Veteran shaft is 1,700 feet deep and is well equipped.

The Ruth mine, the mine that made the district, is developed quite extensively and has a large tonnage of ore ready for caving which is the system to be employed in mining. A new shaft, the Star Pointer, was sunk and connected with the old Ruth workings and will be the main outlet for the mine when shipments from it begin. The shaft is more conveniently located on the railroad and is well equipped to handle 2,000 tons of ore per day. A drift from this shaft has been run under the old Ruth dump, which contains a large tonnage of commercial ore, to which an upraise has been driven and this ore by these workings will be transferred to and raised through the Star Pointer shaft.

The present total tonnage produced by the Nevada Consolidated amounts to between 7,000 and 8,000 tons per day and comes almost wholly from the steam-shovel pits which now cover about 35 acres and have a maximum depth of 185 feet. Five steam shovels are working here stripping overburden and mining ore. Three of these machines have 5-yard dippers, one has a $3\frac{1}{2}$ -yard dipper and one has a 3-yard dipper. The first four are 95-ton and the last a 70-ton shovel.*

Churn drills are used for both prospecting and blasting holes. The cost of churn drilling here varies greatly at different holes, but at one mine averaged \$1.87 per foot. Depending upon conditions, 25 to 120 feet are drilled per 24 hours. When prospecting the ore, drill holes are put down at the corners of 100-foot squares and samples of the bore are taken every 5 feet.

The overburden removed by the steam shovels is loaded into Oliver contractor-type dump cars of 12-cubic-yards capacity, which weigh empty 28,000 pounds each. These are hauled in trains to other portions of the property whose surface is used for a dumping ground.

The ore is hauled to the reduction works 20 miles up the valley in trains of 20 cars each. The latest ore car is of the Inglesby type, which with a load limit of 120,000 pounds, weighs only 37,800 pounds. Five of these cars are loaded in 12 minutes by the steam shovels, although the total average time consumed is very much greater owing to the unavoidable lost time

*Since this was written two more steam shovels have been added, making seven in all. Four are removing overburden, two are mining ore and the seventh is held in reserve.

required in switching and handling the empties and the loads. The grade of the ore road averages about 14 per cent with a maximum of 3 per cent, but only empties are hauled against the grade. From the mine to the smelter the locomotives use no steam.

For the company's fiscal year ending September 30, 1910, the Nevada Consolidated mined and treated 2,236,434 tons of ore which averaged 2.06 per cent. copper. The Utah Copper, at Bingham, mined and treated 4,340,245 tons of an average grade of 1.54 per cent. The overburden stripped and disposed of amounted to 1,163,069 cubic yards, plus 329,346 cubic yards removed for approach work, making a total of 1,492,415 cubic yards. The total stripping cost was 40.6 cents per yard, equivalent to 15 cents per ton of ore. The mining costs were 15.4 cents per ton. The total cost of mining including every expense, stripping, taxes, eastern office expense, etc., amounted to 30.4 cents per ton of ore. The Nevada Consolidated has now blocked out 40,360,000 tons of ore which averages 1.7 per cent. copper, besides proven ore reserves of 18,000,000 tons averaging 1.25 per cent. copper. The initial dividend was paid late in 1909 and dividends at the rate of \$3,000,000 or \$4,000,000 per year are assured for years to come.

Although the Nevada Consolidated is now the only large producer in Ely, the Giroux is expected to be soon a large factor in the output of the camp. The Giroux is controlled by the Cole-Ryan interests. This mine though extensively developed has never been a producer except on a sufficient scale to furnish ore for its experimental mill at Kimberly. A small smelter was also erected here but the building burned down before the single blast furnace was blown in and it is now wholly unsuited in size, in type, and in location for present needs. A 2,000-ton concentrator and smelter are in contemplation. Water for this experimental plant was obtained

from the 1,000-foot level of the company's Alpha shaft, and was ample for the purpose. Underground development and churn

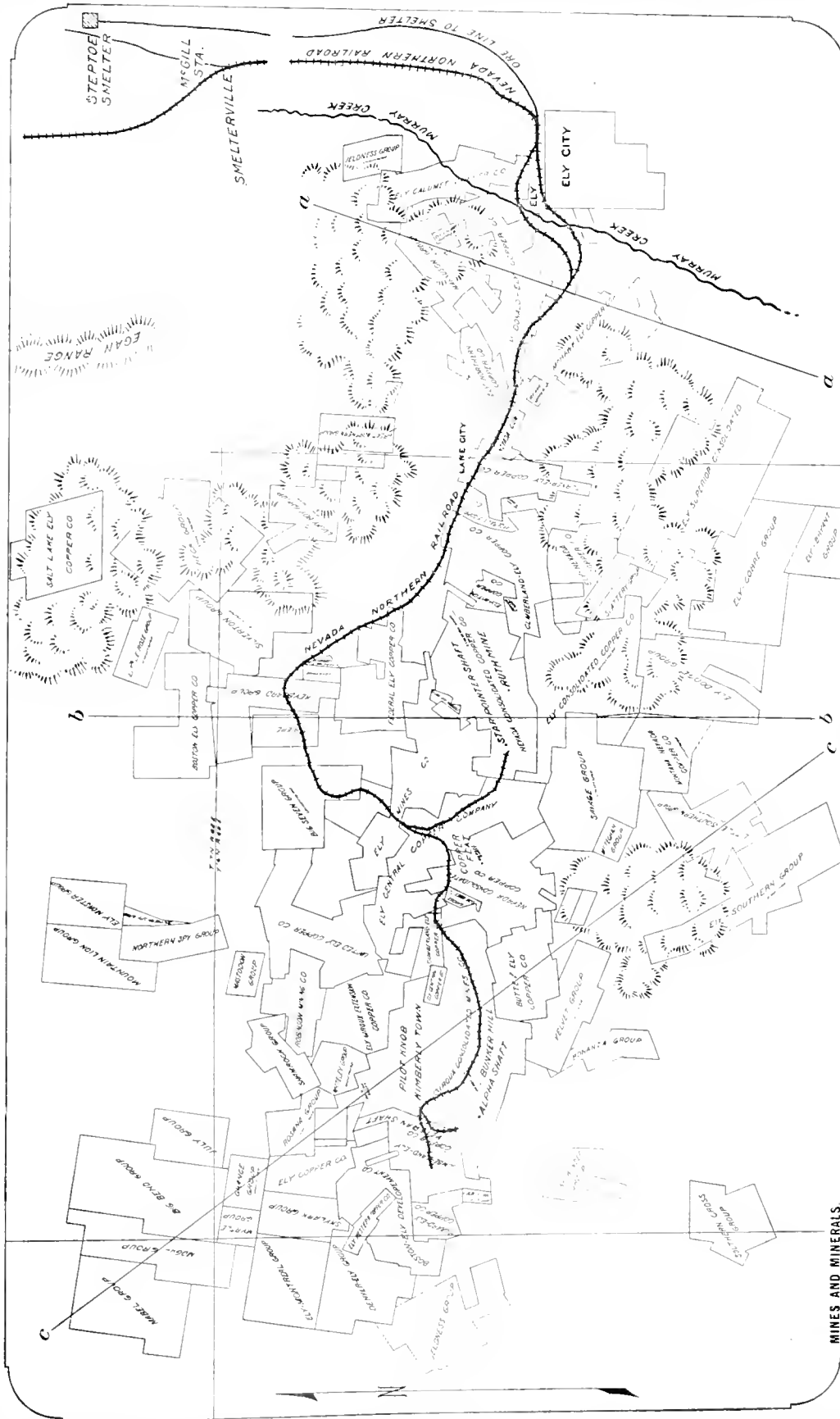

drilling from the surface have been carried on aggressively with continuously satisfactory results. In the Alpha shaft, where the

remarkable feat was accomplished of rescuing alive two entombed miners after 45 days burial, water was encountered below the 1,000-foot level, which increased at the 1,200-foot level beyond the capacity of the pumps, and the workings below the 1,000 were drowned. A westerly drift about 1,000 feet long was run to a point chosen for a new shaft, the Giroux, and sinking and raising were carried on until the connection was made. This shaft, 12 ft. x 19 ft. 6 in. with five compartments, was then timbered with regular shaft sets to replace the temporary timbering used in driving. The timber purchased for this shaft amounted to about 750,000 board feet. Two 600-gallon steam-driven mine pumps handle the water through extra heavy steel pipe columns with solid steel forged flanges. The Giroux has a total development of 9,620,000 tons which average 1.9 per cent. copper.

The Butte-Ely group had been acquired by the Giroux before the advent of the Cole-Ryan interests.

The Ely-Amalgamated, owning property which adjoins the McGill smelter site on the east and extending over the mountain ridge into what has always been referred to as Duck Creek district, has been acquired by Salt Lake interests, including Keith and Kearns of the Silver-King and Jesse Knight of Provo, and extensive work on the lead-silver deposits has been done.

The Boston-Ely has a deep shaft driven in the limestone to cut the Ely porphyry below. The shaft is about 1,500 feet deep.

A considerable amount of leasing has been going on in the camp for a long time. Now there are nearly 200 men thus engaged, principally on lead-silver ores. The Elijah lease has been operated off and on for 30 years.

The reduction works at McGill, including both the concentrator and the smelter, are known as the Steptoe Valley plants and are owned by the Steptoe Valley Smelting and Mining Co. This company is now owned in toto by the Nevada Consolidated. The concentrator was originally designed for less than 6,000 tons per day but recent additions of various improvements have largely increased its capacity until now it is treating over 8,000 tons per day. The ore is crushed by rolls and Chilean mills and is concentrated on Wilfley tables and Frue vanners. The concentrates are dewatered in steel tanks and are then loaded into trains of cars, running underneath the tanks, by means of Blaisdell excavators. Milling costs 55 cents per ton of ore. The ratio of concentration is 10.6 and the recovery is 69.5 per cent. There are employed in and about the mill about 300 men, millmen and laborers. Millmen receive \$3 and laborers \$2 per 8-hour shift.

The smelter has five reverberatory furnaces 112 ft. x 19 ft., each of which has two 400-horsepower waste-heat boilers in parallel at the front or skim end. The reverberatory ash is used in the power-house boiler plant, being fed to the furnaces of the water-tube boilers by automatic stokers and burned by means of mechanically induced draft. There is one water-jacket blast furnace for smelting ladle skulls, etc. The roaster plant consists of 16 McDougall furnaces. The converter plant has four stands of converters and three casting machines admirably arranged for the work in hand. The matte regularly converted is about 40 per cent.

During the last fiscal year the Steptoe plants produced 60,513,009 pounds of refined copper. For the last quarter of the year the total cost of producing copper was 6.8 cents per pound and for the whole year the cost averaged 7.05 cents.

Ely is to be served by more railroads. About 20 miles south of Cobre and 120 miles north of Ely the Western Pacific crosses the Nevada Northern at Shafter. While this road does not go into Ely, it gives the camp another outlet and makes it independent of the Southern Pacific, on which it was formerly wholly dependent. The Ely-Goldfield road will connect Ely through the Tonopah and Goldfield and the Tonopah and Tidewater roads with the Santa Fe, and thus afford it an outlet to Los Angeles and give it the advantage of the water rates to the coast. This road will cross the Giroux property between the

Alpha and Giroux shafts. A new road east from Ely running through the Deep Creek country on the western border of Utah to Tooele, Utah, is now being rather aggressively boosted. This road would serve the double purpose of opening up the Deep Creek country, which of itself has never been able to gather momentum enough to get the road, though it has a very large-tonnage of ore in sight, and of affording an outlet for the Ely ores, especially the Giroux, to the International smelter at Tooele. Ely is therefore in a very comfortable position regarding transportation facilities whereas only five years ago the stage and the ubiquitous burro were the only means of transport.

來 來

The Post Office After Mine Frauds

Walter P. Edris, postmaster of Spokane, has received a fraud order issued by the Post-Office Department, effective at once, against C. E. Mitchell, a promoter, convicted in the federal court there last May on the charge of using the United States mails in furthering certain worthless mining properties. It also is specified that money orders received prior to June 12 must not be cashed but taken up, if presented for collection, and the money refunded to the senders. The order is against the following: C. E. Mitchell, Spokane, Wash.; The C. E. Mitchell Co., Box 2234, Spokane; Blue Bell Belcher Mining Co., successor to the Coeur d'Alene Eagle Mining Co., Spokane; Snowstorm Deep Mines, Ltd., successor to the East Snowstorm Mining Co., Spokane; Coeur d'Alene Reliance Mining Co., Spokane; Lee-Jumbo Mining Co., Spokane; Montana Mining Co., Spokane; Montana Mammoth Mining Co., Thompson, Mont.; C. E. Mitchell, president Montana Mammoth Mining Co., Thompson, Mont.; J. R. Kemp, agent Mitchell Mining Operations of Spokane, E. 11 Lexington Street, Box 3, Baltimore, Md. All offices and agents of any of these companies, wherever located.

Mitchell was convicted following a sensational trial on an indictment returned by a federal grand jury, charging him with fraudulent use of the mails in promoting worthless mining enterprises. The trial consumed 10 days and was expedited by agreement of counsel whereby an innumerable mass of correspondence was not read to the jury, but was sent with the jury to its room.

United States Attorney Oscar Cain, who handled the case, announces that the conviction was secured at an expense to the government of about \$15,000. Thousands of letters written by Mitchell to prospective customers had been gathered and from this mass of correspondence and more than 50 witnesses from various parts of the United States, the district attorney was enabled to make out a convincing case.

The dramatic moment of the trial came at the conclusion of the government's case, when a letter from Mitchell to one of his agents was read, in which Mitchell said: "For years I have been known as the king-pin grafter of the Spokane country." A conviction was secured in less than two hours.

來 來

Valuable deposits of gypsum, in Nova Scotia, are mentioned in a recent United States Consular Report. The exposures are said to show beds of from a few feet to hundreds of feet in thickness, ranging in color from gray to snow white and frequently of the best quality. Some of the deposits have been operated for nearly a century, but during all that time only two mills have been established for the manufacture of gypsum products, one at Windsor, in 1901, and the other at Cheticamp, Cape Breton, in 1908. In 1908, about 300,000 tons of gypsum were produced in Nova Scotia, while in 1910 the production amounted to 322,974 tons. Practically all this was shipped to foreign countries, \$290,949 worth being sent to the United States and there manufactured into different products.

Mines and Minerals

Vol. XXXII—No. 2. SCRANTON, PA.—SEPTEMBER, 1911—DENVER, COLO. Price, 25 Cents

PUBLISHED MONTHLY AT SCRANTON, PA.

ESTABLISHED 1881

WESTERN EDITORIAL OFFICE: 728 Equitable Building, Denver, Colo.

CHICAGO OFFICE: 1006 Michigan Ave.

Entered at the Post Office at Scranton, Pa., as second-class matter.

Address all business communications to MINES AND MINERALS, Scranton, Pa.

CABLE ADDRESS, "RETSOF, SCRANTON"

LONDON OFFICE: INTERNATIONAL BUILDINGS, KINGSWAY, LONDON, W. C.

SOUTH AFRICAN OFFICE: MANSION HOUSE CHAMBERS, ADDERLEY STREET, CAPE TOWN.

NEW ZEALAND OFFICE: 63 DIXON STREET, WELLINGTON.

AUSTRALIAN OFFICE: 53 PITT STREET, SYDNEY.

SUBSCRIPTION RATES

Single Copies.....25 cents

Yearly Subscriptions, including postage:

To United States, Mexico, Cuba, Porto Rico, Hawaii, and Philippines. \$2 00

To Canada.....2.50

To all other countries.....3.00

The date after your name on the wrapper is that of the month to which your subscription has been paid. If you do not want to continue your subscription after that time, kindly notify us.

Notice to discontinue or change of address should be sent to the Scranton office.

When notifying us of a change of address always give your FORMER as well as your present.

Electric Mine Lamps

THAT progressive American mine managers are alive to the advantages of better and safer lights for miners is evidenced by the fact that in this issue we publish two illustrated articles on the development of electric mine lamps, one being based on the experiments and developments worked out by the Philadelphia & Reading Coal and Iron Co. in Pennsylvania, and the other by the officials of the Cedar Hill Coal and Coke Co., of Colorado.

In neither instance did the men who produced the practical lamps described in the articles know what the others were doing, and the descriptive articles were written by different authors who had no knowledge that they were preparing articles on similar lines.

In addition, the Buffalo and Pittsburg Coal Co. are giving the Pilley electric mine lamp a thorough test under actual working conditions at the Marianna mine in Western Pennsylvania.

來 來

Revival of Gold Mining

INDICATIONS all point to a healthy revival of gold mining; not that there has been a cessation of work at the prominent producers, but because so many old mines are starting up throughout the West.

At this writing there is not so great need of cautioning investors against the wiles of fake promoters, owing to several states exposing and the Federal Government prosecuting them, nevertheless there are a number of important matters which investors in gold mines should understand. There are a few gold deposits discovered at long intervals which make poor men rich, and when they are found the owners do not ask outside assistance. The majority of deposits are low grade and require large sums of money in order to work them successfully, because large mills must be erected to concentrate or treat the ore. Since there must be a large tonnage worked to make such mines pay, the proposition is unsuited to companies of small real cash investments. The Homestake, the Alaska-Treadwell, and the South African gold mines belong to this class.

Those gold mines which are a mean between the small bonanza and the large low-grade deposits usually contain partly high grade and partly milling ore, such as some of the Goldfields and Tonopah, Nev., mines are working to advantage. Nearly every patriot and some who are not patriots take a dip in gold mining during their career, mostly, however, in a speculative way after consulting the man with the big diamond in his tie, who

TABLE OF CONTENTS

EDITORIAL—	
Electric Mine Lamps—Revival of Gold Mining—An Historic Mine—	
Coal Mining in Arkansas.....	65
OUR COVER PICTURE.....	66
COAL MINING AND PREPARATION	
THE COALDALE HEAD-HOUSE.....	67
NATIONAL MINE SAFETY DEMONSTRATION.....	69
PANEL SYSTEM OF LONGWALL MINING, by C. E. Krebs.....	70
LEHIGH VALLEY FIRE-FIGHTING CAR.....	71
CALORIFIC VALUE OF ANTHRACITE.....	72
CHOCKS FOR CHAIN HAULS.....	73
APPLIANCES FOR PREVENTING ACCIDENTS, by Stephen L. Goodale.....	74
COAL DUST EXPLOSIONS, by John Verner.....	78
VICTOR SAFETY LAMP, by Mark O. Danford.....	79
COAL MINING NOTES.....	80
LESSONS TO BE LEARNED FROM RECENT DISASTERS, by John Verner.....	81
METHOD OF TESTING MINERS' OIL.....	82
BOOK REVIEW.....	82
PROFIT AND LOSS ACCOUNT, by Neil Robinson.....	83
SYKESVILLE, PA., EXPLOSION.....	84
COAL DUST AND ZONE SYSTEMS.....	85
COAL PRODUCTION IN JAPAN, by T. Haga.....	88
COMO MINE, No. 5, by Joseph Watson.....	89
CORRESPONDENCE.....	90
ELECTRIC MINE LAMPS, by J. T. Jennings.....	91
THE TWO-MILLION-DOLLAR TRESPASS SUIT.....	92
DISPOSAL OF ASHES AT MINE BOILER PLANTS.....	93
ECONOMICAL FIRE-ROOM METHODS.....	94
COAL COMBUSTION RECORDERS.....	96
EXAMINATION QUESTIONS—	
Pennsylvania Anthracite Mine Inspectors, Scranton, May 25, 26,	
1911, and Utah Mine Foremen's.....	97
ORE MINING AND METALLURGY	
THE CORNWALL, PA., MAGNETITE DEPOSITS.....	99
THE GIESECKE TUBE MILLS, by R. G. Mackie.....	102
AMERICAN GEM MINES AND MINING, by John L. Cowan.....	103
VANADIUM, ITS PROPERTIES AND METALLURGY, by F. W. Brady.....	106
CHILIAN MILLS AND AMALGAMATION, by H. C. Baylton.....	106
MANGANESE IN IRON AND STEEL.....	107
TRADE NOTICES.....	110
TIN DEPOSITS IN EL PASO COUNTY, TEXAS, by Regis Chauvenet.....	111
EMPIRE MINE AND MILL, GRASS VALLEY, CAL., by Al. H. Martin.....	113
JOPLIN DISTRICT ZINC NOTES.....	114
TREATING LOW-GRADE ZINC ORE, by Lucius L. Wittich.....	115
MINING IN POVERTY GULCH, by Charles W. Henderson.....	116
COPPER MINING NOTES.....	118
HYDRAULICKING WITH WASTE WATER, by Lucius L. Wittich.....	118
PERSONALS.....	119
RELATION OF FORESTRY TO MINING, by J. F. Lawson.....	120
GENERAL ORE MINING NOTES.....	121
PORCUPINE FOREST FIRES.....	123
THE ELMORE FLOTATION PROCESS.....	124
LABORATORY SIZING TESTS, by F. Curtis.....	125
SETTLING CHAMBER FOR SNELFER FUME, by J. I. Blair.....	125
CALORIMETRIC ESTIMATION OF GOLD.....	126
CATALOGS RECEIVED.....	126
NOTES ON PYRITE AND MARCASITE.....	127
SQUIBS—	
Electric Machinery for Mining, 66—Coal Industry of Nova Scotia,	
69—First-Aid in Singapore, 71—Calcium Chloride as a Dust	
Preventative, 73—Oil and Coal in Honduras, 77—Miners in	
Arkansas, 80—Theoretical Water Gauge, 87—Water-Gauge of	
Fan, 87—Oil Fields of Lambton County, Ontario, 89—Mining in	
Spain, 90—Society Meetings, 93—Petroleum in Borneo, 95—Tin	
plate Trade of the United States, 1911, 96—Systematic Tunnel	
Driving, 105—A Remarkable Wire Rope, 105—Copper Ores in	
Nova Scotia, 112—World-Wide Figures, 123—Process Fakes	
and Business Men.....	128

whets their cupidity with tales of Blue Birds, Independences, Goldfield Consolidateds, etc.

No one should invest in a stranger's mine without verifying the tale by an engineer who is either personally known, or vouched for by another well-known mining engineer.

During the early days of mining in this country many good gold and silver properties were located where \$100 and \$200 ore could not be made to pay. Many other good prospects became failures through insufficient capital and lack of knowledge regarding the recovery of gold and silver. These properties are being picked up and worked in an intelligent manner; and, owing to better transportation facilities and modern metallurgical methods, are paying. The investor should also understand that gold veins and coal beds are as dissimilar in formation as the two minerals themselves, and therefore if he cannot invest in prospects on the vein it is policy not to invest at all in that particular district. Before a man can apply for a claim he must uncover a vein, if he does not and tries to raise money to work the claim, he is a fraud.

采 采

An Historic Mine

ON page 89 of this issue we present one of the most important contributions of recent years to the history of American coal mining.

In this article the date of the first watering of coal dust in mines of the United States is set five years earlier than the date given by Mr. George S. Rice of the U. S. Bureau of Mines. In Bulletin No. 425 of the U. S. Geological Survey Mr. Rice says, "in the United States the system of watering by hose and nozzle has been employed in the coal mines of Utah since the Scofield disaster of May 1, 1900," and he gives that date as being the time of the first use of water in laying the dust in American mines.

To Mr. Joseph Watson, then superintendent of Como No. 5 mine, at Como, Park County, Colo., and now general superintendent of the National Fuel Co., at Louisville, Colo., must be given the credit of having adopted this system 5 years earlier than the date set by Mr. Rice; viz., in May, 1895. It also seems probable that to Mr. Watson is due the further credit of having first employed shot firers in the mines of our country.

If any of our readers are advised of an earlier date than May, 1895, on which watering of dust was practiced or shot firers were employed in American mines we shall be glad to hear from them.

采 采

IN the August issue of MINES AND MINERALS there was an article on "Coal Mining in Arkansas," by A. A. Steel, Professor of Mining in the University of Arkansas. This was selected from a description of "Arkansas Coal-Mining Methods," published by the Arkansas Geological Survey for the information of persons unfamiliar with coal mining and as an intro-

duction to a technical report. Considerable interest is being manifested in Arkansas coal, since outside of Pennsylvania and possibly Colorado the state contains the largest deposit of semi-anthracite so far discovered in the United States. While the bed is not thick it is favorably situated for transportation and there is no appreciable loss of fine coal, the culm finding a ready market at the Kansas-Missouri zinc smelters. The Arkansas coal fields stand in a class by themselves, and the description of them, which will be furnished later, will be of interest to coal men generally.

采 采

Our Cover Picture

The largest mining enterprise in Mexico is that of the Green-Cananea Copper Co., part of which is shown on our front cover. In the foreground to the left is the sampling mill; to the rear of this is the large reverberatory smelter 100 feet long by 19 feet wide, which uses oil for fuel and raises steam with the waste heat. In the center-right foreground is the ore-bedding and mixing plant; to the right rear of this is shown part of the fume chamber. In the left background is shown the power house covering the blowing apparatus, and in the right background are the furnaces.

The promoter in chief of this enterprise, Col. W. C. Green, died recently from injuries received in a runaway.

采 采

Electric Machinery for Mining

W. A. Thomas, engineer for the Westinghouse Electric Co., writes as follows:

In the matter of power there is a notable tendency to the development of central energy plants at mining operations, instances being the plant of the Consolidation Coal Co. at Van Lear, Ky., with turbogenerators, condensers, and sub-station equipment; the Clinchfield Coal Corporation at Dante, Va., with the development of a 2,000-kilowatt plant and four sub-stations. These show that coal-mine officials appreciate that the value of fuel is what it can be marketed for.

The Homestake Mining Co., at Lead, S. Dak., is just completing a 6,000-kilowatt hydroelectric installation by diverting the Spearfish River through 25,000 feet of rock tunnels to a cañon, thus securing about 400 feet head for the development of waterpower to generate electricity that will be transmitted approximately 15 miles to gold-mining operations.

The application of electricity to pumping has made remarkable advances in mining operations, installations of importance being that of the Ward Shaft Association in the old Comstock mines at Virginia City, Nev., consisting of four 250-horsepower completely enclosed motors with forced ventilation by driving air first through cooling coils, then through the motors and again through the cooling coils, the water pumped being at a temperature of approximately 175° F. 2,500 feet below the surface of the ground, and the water for the cooling coils being taken from the surface at approximately 80° F.

An important improvement of the past year has been that of small, self-starting, direct-current motors for isolated pumping in and around coal mines. These motors are made with especially strong commutating facilities, so that they can be connected directly across the line without injury, the advantage being that starting devices are unnecessary and the pumps can be allowed to run constantly. In the event of the circuit being opened, no injury will develop when the power is again connected to the line with the motor on the circuit.

The past year has witnessed a number of installations of steel-frame mine locomotives. This construction reduces frame breakage, makes stronger locomotives and permits greater horsepower of electrical equipment on a given weight of engine.

COAL MINING AND PREPARATION

The Coaldale Head-House

A Plant for Separating Large Amounts of Rock and Preparing Anthracite for Market

The Lehigh Coal and Navigation Co. is the oldest of the anthracite companies and the first company to ship coal from Northeastern Pennsylvania. Its product in the market is known as Old Company's Lehigh. In the early days this company constructed the famous Mauch Chunk switchback which hauled the empty coal cars to the top of Mt. Pisgah over an incline and allowed them when loaded to run by gravity

and to deal with unusual mining conditions in an unusual manner.

The Mammoth coal bed in this vicinity varies in thickness from 50 to 80 feet and is split by a bed of rock, which must be removed with the coal. To add to the difficulty of separation the bed is steep pitching, making it necessary to remove all material from the rooms, there being no place to stow gob, which probably averages 25 per cent. of the material hoisted to the dump. To avoid sending this rock through the breaker machinery, it was decided to eliminate the greater part of it as it came from the mine, and to this end an innovation in anthracite breaker practice was planned and a head-house erected. The head-house head-frame, and the pan conveyer run-

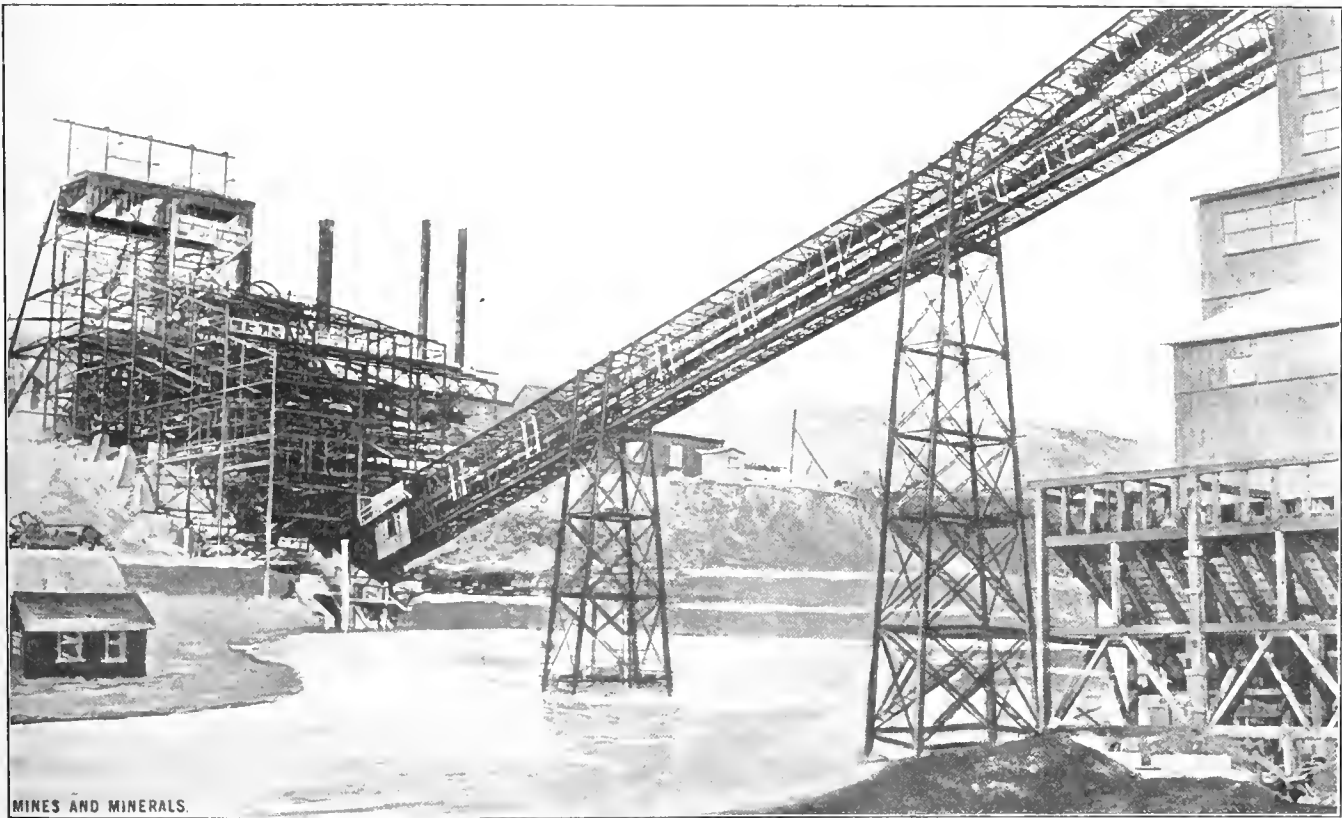

FIG. 1. HEAD-HOUSE, HEAD-FRAME AND CONVEYER AT COALDALE

from Summit Hill to the Lehigh Canal. Afterwards they constructed a railroad. This, however, they leased to the Central Railroad of New Jersey and then shipped their coal over it. At the present time they are constructing another road over which they intend to ship their product to New England.

Because it is the oldest anthracite coal company, it does not follow that its management from the president down are in any way unprogressive; in fact being coal mining engineers of long experience they are able to see and take advantage of any improvement that will lessen the cost of operation. The headquarters of the operating department are at Lansford in Panther Creek Valley, and possibly three-quarters of a mile away are the Coaldale head-house and breaker, the subjects of this article. These are two separate structures planned to meet the requirements of the mine openings relative to the railroad,

way shown in Fig. 1, was designed and erected by the Jeffrey Mfg. Co., of Columbus, Ohio. It is served by two shafts, No. 8 and No. 9, shown in Fig. 2 and is built so as to be in line with them. The No. 8 shaft has three compartments, two for hoisting coal and one for hoisting water in tanks, a system which has been adopted as more economical than pumping in the Schuylkill region where the depth is more than 500 feet.

On top of each water bucket there is a circular compartment which will hold five men and this is made use of by those who desire to enter or leave the mine during working hours, at the same time it leaves the cages free to hoist coal.

The two-compartment shaft known as No. 9 receives coal from three different directions from the deep workings, from the drift workings and from an opening across the valley. To accommodate the cars from the latter mines the two tunnels

shown are directly under the shaft house. When cars are being hoisted from the mine others accumulate on the drift level which makes it necessary to hoist for a given time from each level. The change in rope length is made so quickly, that the only loss in time is that necessary to hoist the empty cages from the bottom to the tunnel landing.

All four cages are of the self-dumping type, known as the Jeffrey automatic drop-rail cages, the cars dumping their loads as they reach the top of the head-house without leaving the cages. The hoisting engines or the coal compartments are at right angles to those for the water compartment, and the drainage tunnel is below the drift level in shaft No. 8.

In Fig. 4 a plan of the head-house flow sheet is given. The cars discharge the coal on an inclined chute, having as its lower end a rotary feeder *a* which in revolving permits only a measured quantity to go on the platform screens *b*, thereby avoiding a rush with the attendant difficulties of flooding and poor rock picking. Just enough coal is measured out by the rotary feeders to allow a uniform quantity to pass on the shaking platform screen where it is riddled through 6-inch diameter round holes. That coal which passes through, not having been sepa-

rated from refuse, is designated as dirty coal; that material which passes over is in large pieces, and after the rock is picked from it on the moving table it is termed clean coal.

The dirty coal goes by gravity to the dirty-coal shaking screens *c* where anything above 3 inches in diameter is called steamboat coal and what passes through goes direct to the dirty-coal carrier *d* and by this is raised to the top of the breaker. The material that passes over the dirty-coal steamboat shakers is hand picked on the table *e* and then being comparatively clean coal is sent to the steamboat rolls *f*, where it is broken and sent down a chute to the clean-coal carrier *g*, which raises it from the bottom of the head-house to the top of the breaker 256 feet distant.

The coal and rock which passes over the platform screen *b* in large pieces falls to the lump-coal picking table *h*, which is an endless belt that travels so slowly that men on each side of it have time to pull off the clean rock on one side, and the rock with coal frozen to it on the other side. The latter are separated by a pick and sent to their proper destination through holes in the floor. The rock chutes from the platform terminate at a point where a traveling belt running at right angles receives the rock and removes it to the rock bin. From this bin it goes by

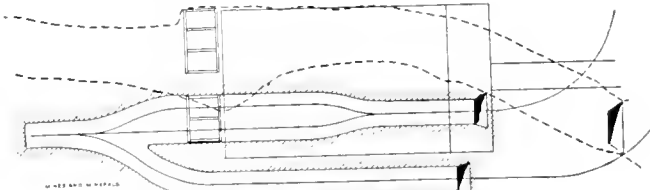
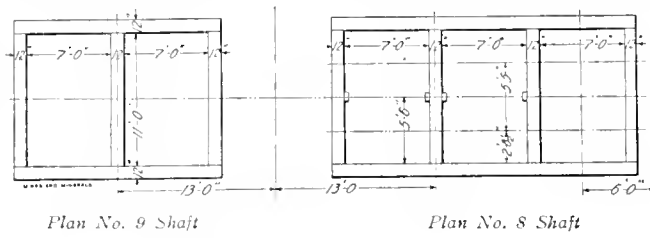

FIG. 2. PLAN OF COALDALE PLANT

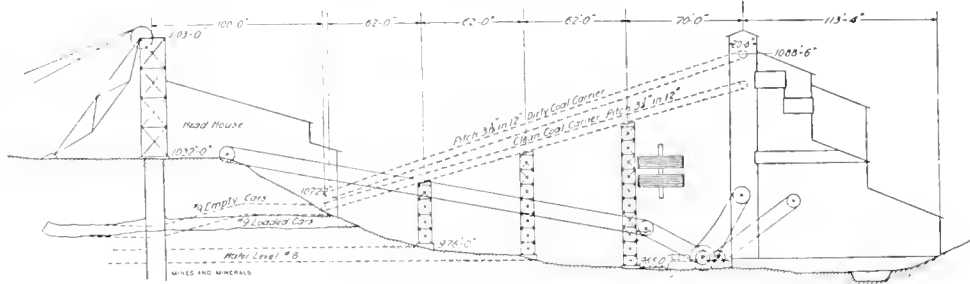

FIG. 3. PROFILE OF COALDALE PLANT

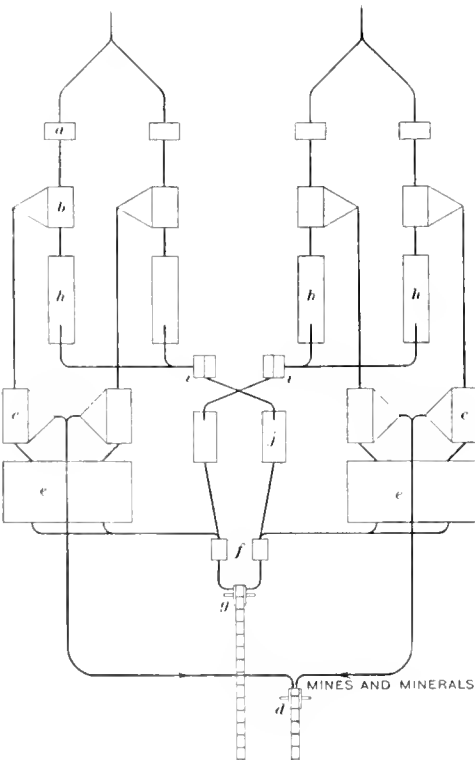

FIG. 4

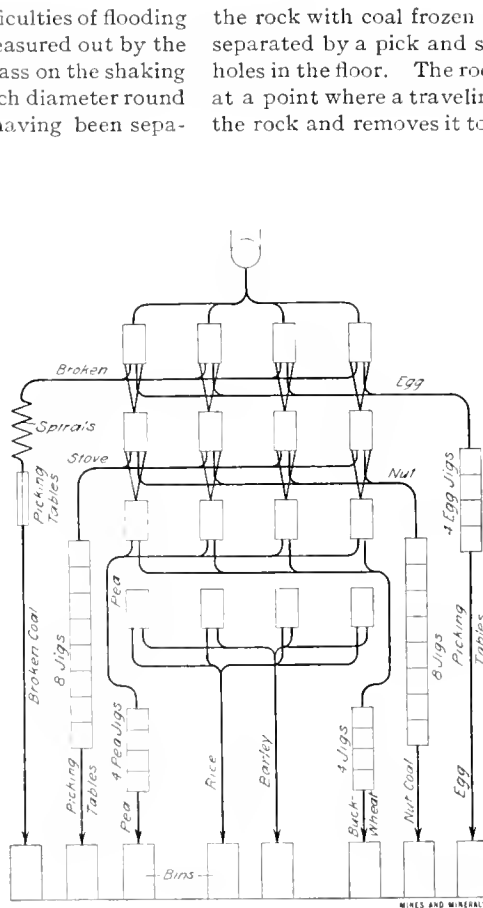

FIG. 5

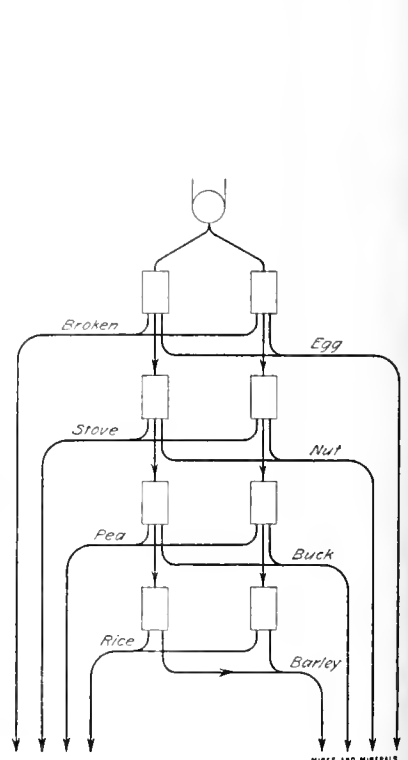

FIG. 6

car to the rock pile and is wasted. The quantity of rock thus handled soon makes an enormous pile, but, unlike many rock dumps in the anthracite fields, it is free from coal. The lump coal from the picking table goes to coarse rolls *i* where it is broken and passed on to the clean-coal steamboat shakers *j*. The clean coal passing through these screens goes direct to the clean-coal carrier *g*, while the coal going over the shakers goes to the steamboat rolls *f* and then to the clean-coal carrier *g*.

The saving in machinery and time by the use of this preliminary preparation is such that the Coaldale plant holds the record for coal treated in a single breaker in the Southern Coal Field, it amounting to 777,714 tons of market coal in 1910, the first year of its operation. The conveyer lines, which have been called carriers, raise the coal approximately 81 feet, or about 122 feet above the loading tracks at the breaker. The horizontal distance between sprocket wheel centers of the dirty-coal carrier is 256 feet, the pitch being $3\frac{3}{8}$ inches in 12 inches. The material delivered is sized into broken and egg coal, stove and nut coal, pea and buckwheat coal; and rice and barley coal by the wet process. The broken coal passes through spiral pickers which separate most of the impurities, then to picking tables and from them to the broken-coal bin. The egg coal passes over a screen having 2-inch meshes and through a $2\frac{1}{4}$ -inch mesh and is jigged to separate it from impurities. After jigging it is hand picked before passing to its bin. The stove coal is treated in the same manner. The nut, pea, and buckwheat are jigged and passed to their respective bins, the wet separation being sufficient. Rice and barley sizes are not jigged. The flow sheet of the dirty-coal side of the breaker is shown in Fig. 5, and the clean-coal flow sheet in Fig. 6. It will be noticed in the latter instance that no other machinery but that necessary for sizing is needed, the coal having been thoroughly prepared in the head-house.

In Fig. 1 is shown the steel framework of the head-frame head-house and conveyer runway at the time of its completion. The head-house and runway were afterwards covered with corrugated metal siding, thus making the structures practically fireproof. In the runway there are steps the entire length of the pan and two sets of conveyers from the foot of the head-house to the top of the breaker. The dirty-coal conveyer is constructed with flat bottom pans 24 in. x 36 in.; the clean-coal conveyer has similar pans 24 in. x 24 in., both being open-top overlapping with sides extended. The dirty-coal conveyer has a capacity of 300 tons per hour; the clean-coal conveyer a capacity of 150 tons per hour when traveling at a speed of 90 feet per minute.

Those who attended the Glen Summit meeting of the American Institute of Mining Engineers were shown this plant, and were immediately interested in what appeared to be two breakers 250 feet apart connected by an inclined conveyer. Many of them, however, who were not versed in the peculiar conditions that suggested this method of treatment, failed to fully comprehend that the preparation of anthracite for market is a coarse concentration process which produces a product that compares with the best ore milling practice.

As an illustration of the progressiveness of this company it is stated that it was the first to erect a briquet plant for anthracite. The readers of MINES AND MINERALS are indebted to Manager Baird Snyder, Jr., Mechanical Superintendent C. A. Straw, and their assistants for the information incorporated in this paper.

采 采

Coal Industry of Nova Scotia

The value of the output of coal from the 16 mines operating in Nova Scotia in 1910 is given by United States Consul at Halifax as \$15,675,000, against \$14,200,000 in 1909. In these mines 14,000 persons were employed, not including those on the railways and steamships engaged in transporting the output.

The fleet regularly employed for the carriage of coal, ore,

and limestone consists of 26 steamers, of a total of 135,600 tons, in addition to two seagoing tugs and a number of barges and lighters.

The total annual disbursement for wages at Sydney and vicinity is \$15,000,000. Coal to the value of \$368,146 was shipped to the United States during 1910.

采 采

National Mine Safety Demonstration

Arrangements have been definitely perfected for the first National Mine Safety Demonstration, to be held in Forbes Field, Pittsburgh, Pa., October 27. This will be conducted under the auspices of the Bureau of Mines and the Pittsburgh Coal Operators' Association, with the cooperation of the American Red Cross. There will be souvenir programs, souvenir buttons, a military band, and public speakers, including President Taft, Secretary of the Interior Fisher, and Governor Tener, of Pennsylvania.

Trained first-aid teams from many of the important coal-mining centers in the United States have been invited to participate and a large attendance is anticipated.

In view of the fact that this is not a competition for prizes, but an exhibition in skill in administering first aid to persons injured in mines, and with a view to creating interest in instruction of this nature, it is hoped that the plan will appeal to all mine operators and that they will endeavor to interest as many mine workers as possible in this worthy movement.

The following are the program and rules:

1. Non-competitive exhibition of skill in first aid to the injured in mines, to be held in Forbes Field, Pittsburgh, Pa., October 27, 9 A. M. to 1 P. M.

2. Not more than one team of five men to represent any one coal mine, or the United States Bureau of Mines, or state mine departments, provided that coal mining companies operating more than one mine may enter additional teams representative of groups of miners, helpers, trapper boys, or other mine workers.

3. All persons entering to submit certificates showing that they are, or have been, bonafide mine workers.

4. All entries to close 1 month prior to date finally selected for the meet.

5. Coal companies entering teams to be invited to present, not later than 1 month in advance of meet, a list of five events as their choice, these to be submitted to the managers, who will select five for adoption from the various events suggested, each entering team to exhibit in those events suggested by them, and such others of the five as they may elect. All teams to exhibit in unison.

6. Should any unusual or valuable events be suggested, the managers may increase the program by one or two such special stunts.

7. In addition to the five first-aid events there will be a representation of a coal-dust explosion, with rescue by helmet-men and first-aid treatment.

8. Exhibition of skill in adjusting and use of rescue apparatus by teams of four with a captain; entries to be as above for first-aid teams.

9. Exhibition in use of fire extinguishers upon a fire by members of the rescue crews.

10. Souvenir badges of the American Red Cross, souvenir buttons of the United States Bureau of Mines, and souvenir programs to be presented to individual entrants; a souvenir first-aid box to be presented to each team entering; a souvenir pennant with the name of the company sending entrant, and to be used on the field as a marker, to be presented to the company represented.

11. There will be introductory remarks by the Director of the Bureau of Mines and a member of the Executive Committee of the American Red Cross.

12. Presentation of souvenirs will be made at the close of the exercises in brief addresses by speakers of national repute.

Panel System of Longwall Mining

C. E. Krebs*

The mining methods generally used in West Virginia in mining coal have been the room-and-pillar system, which was probably adopted on account of its first low cost of development, and possibly also it was not expected to extract all the coal from the seam. This method has played havoc with many mines, and millions of tons of coal have been lost that can never be recovered because of its use, or rather misuse. Then, too, it is true that thick seams of coal were the first mined where this method of mining was peculiarly fitted, but the thickest seams are being worked out very rapidly, and thin seams of coal will have to be worked and at a minimum cost, so as to meet the competitive price of coal in the market.

To meet these demands the writer will briefly discuss a method of longwall mining, which he believes, if adopted, will add materially to the solution of the question of first cost, maximum recovery of the coal, and minimum loss of life and property and with greater safety to those so employed in its use.

We are told by mining men coming from Europe, that longwall mining has long been successfully used in the mines of

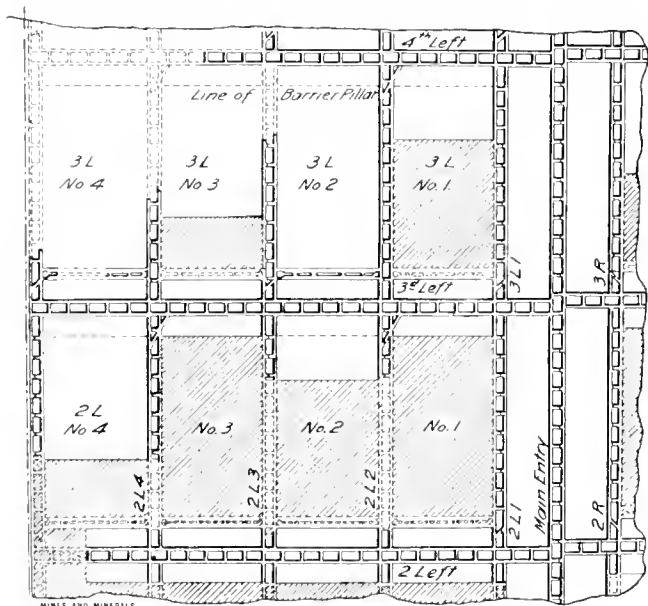

FIG. 1. LONGWALL MINING WORKED ADVANCING

those countries and that it is now successfully employed there, but it appears the system used by them was the retreating system of mining and not the advancing.

In order to use the retreating longwall system as it is generally done, it will be necessary first to drive the main entries to the boundary lines of the leasehold before any results can be obtained. This operation is very expensive and can only be done by the strongest and wealthiest companies. It also takes years of a small output to do this work, as only the entry coal is mined. This would naturally make very costly coal during the development.

The system as proposed to be used by the writer is a plan which has been designed by the firm of Clark & Krebs, civil and mining engineers, of Charleston, W. Va., about 2 years ago and a description of which, as given in Fig. 1, is as follows:

The mine can be laid off in a general way similar to that of an ordinary room-and-pillar working; that is, a two or three or even four main-entry system can be adopted, with cross-entries to the right and left, having overcasts for the splitting of the air, and directing the current into these right and left cross-entries.

* Assistant Geologist, Charleston, W. Va. Paper read before West Virginia Mining Institute.

These main entries can have from 20 to 50 feet of a pillar between them, and then be protected by a barrier pillar on each side of them of a width of 200 to 250 feet. The plan shown in Fig. 1 has a two-entry system with 50-foot pillars between the two entries, and a barrier pillar of 210 feet on each side of them. The cross entries are driven at intervals of 1,100 feet on the right and left.

The panel of coal to be mined will be a block of coal 480 ft. \times 850 ft. These panels are worked alternately; that is, No. 1 block on second left is being worked by starting two rooms off 2L1 entry and connecting with two rooms of the 2L2 entry. When this connection is made between these entries the panel is then ready to begin longwall mining. While 2L Block No. 1 is being worked 2L Block No. 2 is not worked, but as soon as the 2L Left entries are far enough then 2L Block No. 3 is worked. Thus, No. 2 Block is retained as a barrier pillar until Nos. 1 and 3 are worked out.

This system can be pursued along this course until the property line is reached.

When the No. 1 and No. 3 Block has been worked to the barrier pillar line then No. 2 Block can be worked. This block will have to be worked retreating, that is to say, the coal will have to be taken from the third left entry and hauled to the main entry.

The system can be worked on each side of the main entry, that is on the right and the left of same, as shown in Fig. 1.

Fig. 1 gives a general plan, but the measurement will have to be revised, and plan made to suit each individual seam as local conditions will govern to a certain extent.

When the longwall system is being actually worked, the face of the coal will have to be undercut to a depth of from 5 to 6 feet by a longwall mining machine, and this cut is cleaned out while the cutting proceeds. In order to keep the coal from falling down in a solid block, stays can be inserted from 5 to 10 feet apart. These stays can be made from timber from 4 inches to 6 inches thick and must be removed before the coal is shot down.

The track is laid along the face of the coal and about 8 feet from it. This will give ample room for the cutting of the coal, and when the cutting is done and before the blasting begins this track can be moved near the face of the coal. This track is connected on both ends to the track in the entries, and curved rails are so attached that it can be easily moved, having also short rails from 4 to 10 feet at each end so as to connect quickly.

Another important feature to be observed is the proper posting of the roof before blasting down the coal. At least three or more tiers of posts should be constantly kept set, but these will have to be regulated in different mines in accordance to the roof that is encountered. The main object is to hold the roof until the coal has been worked out enough in advance, and then to take out the posts behind so that the roof will be allowed to fall, and relieve the excessive weight. However, at least three rows of posts should be left set at one time.

The coal can be hauled with gathering motors, having drums with cables for attachment to trolley wires on the cross-entry or trolley wires can be placed on the roof and moved from time to time as the track is mined.

The system as proposed has the following prominent points in its favor:

It is an ideal one for ventilation, and is well adapted to carry out the state mining laws to the letter. It is beyond question that good pure air is necessary for health and safety of a miner. By this system a current of pure air can be supplied along each working face, and the currents so split that only one panel need be supplied by the same current. It further complies with the mining laws, that less than 60 persons are on one split or current of air.

Each panel is worked independently of the others, and in case of accident it need not disturb the other workings.

Also each panel will be under the direct supervision of a competent and experienced mining man, possibly an assistant foreman, who remains in the working place during the working hours and thereby lessens the chance for dangerous practices among the miners. It will also be much safer in blasting down the coal since there will not be much danger of any blown-out shots. Furthermore, the blasting can be done at night if necessary, when the men are out of the mine.

This system concentrates the men, and tends to bring the cost price for day laborers, as track men, drivers, etc., to a minimum. This cost in some mines is enormous, while by this system it will be comparatively small. It also makes supervision easier, and in every way tends to lessen the work of the mine superintendent. It also lessens the cost of track material, such as ties and rails.

By this system the greatest production can be attained, since it is possible to get the greatest efficiency from the men, machinery, and material.

If this system is correctly operated, it will be possible to obtain more than 95 per cent. of the coal from the seam, and thus eliminate the great loss of coal that can never be recovered.

Mr. Chas. A. Cabell, manager of the Carbon Coal Co., of Carbon, Kanawha County, W. Va., has secured a patent, dated January 3, 1911, from the United States Patent Office of a block system of retreating longwall. His system has a great many points similar to the one proposed by the writer.

He is now installing his system in one of his mines, and the writer sees no reason why it will not work successfully. Mr. Cabell has every assurance that the system will be the one to work low seams of coal.

來 來

Lehigh Valley Fire-Fighting Car

When fires occur in the steep pitching breasts of anthracite mines they are difficult to reach, particularly when the fire-fighters are loaded down with the heavy breathing apparatus which is used generally to protect the men from the coal gas evolved. Under such conditions the men practically become exhausted in 15 minutes and are relieved by another force of men who work 15 minutes. If the fires have not gained too much headway they may be extinguished without great difficulty provided they can be reached with water. Several large operations have installed fire-fighting apparatuses that have been

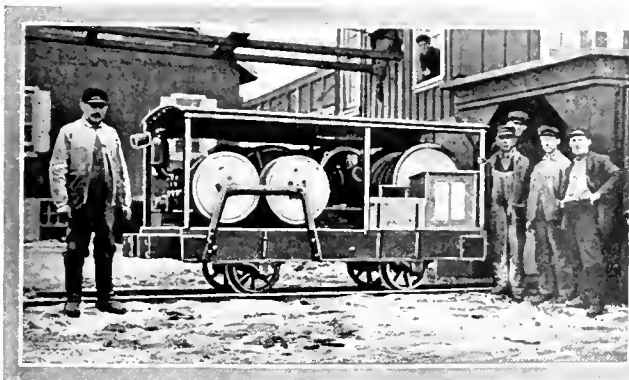

FIG. 1. ELECTRIC FIRE-FIGHTING CAR (RIGHT-HAND SIDE)

described from time to time, but none hitherto so far as known, have made use of electricity for the purpose of throwing water on the fire.

The following description of the fire-fighting car in use at Packer No. 5 and Centralia collieries of the Mahanoy and Schuylkill Division of the Lehigh Valley Coal Co. has kindly been furnished by Division Superintendent J. M. Humphries, Superintendent of that division

On several occasions considerable difficulty was experienced in fighting breast fires at Packer No. 5 colliery, in a vein that has considerable gas, and in one fire in particular the gas became ignited beneath the coal in the breast, the pitch of the vein being about 60 degrees, consequently the breast was worked full. Carrying water to the face in powder kegs up a 60-degree manway is not only very laborious but very inefficient. It is with difficulty that the powder keg is kept full to the top of the breast.

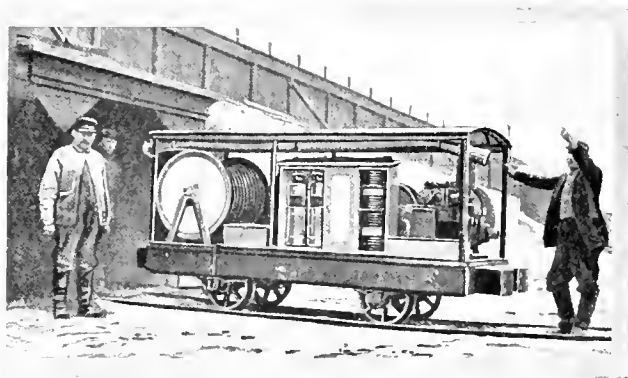

FIG. 2. ELECTRIC FIRE-FIGHTING CAR (LEFT-HAND SIDE)

The thought occurred that some easily portable pump that could be placed upon a mine-car body to pump water from the mine ditch, would not only be much more effective, but it would be very much easier to extinguish such fires. With this idea in mind a truck was designed, the essential parts of which are shown in Figs. 1 and 2. It consists of a 4" x 5" horizontal triplex electric pump with a capacity of 80 gallons of water per minute. The truck is also equipped with the following: 2,000 feet of No. 6 insulated wire; 1 controlling box for the operation of the motor; two 3-gallon fire extinguishers with 16 charges for same; 1 half hatchet; 1 single-bit axe; 1 cross-cut saw; 400 feet of 1-inch rubber hose in 50-foot sections; 50 feet of 3-inch tail-pipe in 10-foot sections, including one 10-foot section 3-inch wire-lined rubber hose with strainer; fittings for connecting 2-inch pipe; 1,000 feet of 2-inch pipe is carried on hand at the colliery solely for fire purposes and the necessary reducers for connecting 2½-inch fire hose, of which there is carried at this colliery, 1,200 feet.

There is also a chest containing all the necessary hospital supplies for giving first aid to any injured persons.

The truck is so designed that it can go to any point in the mines where a mine car can go, and we have two reels of wire that can be extended in the gangway beyond the electric haulage for over 1,000 feet.

The truck is kept on the surface in a fireproof building, on a track and it can be lowered to any lift of the mines within 3 minutes after an alarm of fire has been given.

Several tests have been made with this truck and it has been found very efficient although there has not yet been occasion to use it at an actual fire.

來 來

First-aid work is attracting attention in all parts of the world. A recent United States Consular Report mentions a demonstration recently given by the Singapore Volunteer Corps of a method devised for the utilization of the jinrikisha wheels and axles in connection with stretchers. The body of the jinrikisha was dismantled and a cross-bar placed above the springs, from which projected two upright wings fitted into iron slots attached to the wooden arms of the stretcher. A waterproof awning was placed over all. Army medical men expressed themselves as pleased with the simplicity and ingenuity of the device.

Calorific Value of Anthracite

An Adaptation of the Usual Method of Testing with the Atwater Calorimeter

The following is an abstract from a paper by A. G. Blakeley and E. M. Chance, chemists of the Philadelphia & Reading Coal and Iron Co., Pottsville, Pa., presented before the American Chemical Society, on "The Accurate Technical Estimation of the Calorific Value of Anthracite":

Though much has been published on fuel calorimetry in general, but little has been written on that phase of this subject dealing with anthracite. Moreover, that which has been published is in a large measure discounted, because the coals tested were not examples of the usual merchant sizes. Thus, in the paper published by Parr & Wheeler (J. I. & E. C., Vol. 1, page 673), the two anthracites described contained but 11 per cent. and 13 per cent. of ash, respectively. Palmenburg published the results of an examination of a series of representative coals in Vol. 2, page 404, which range from 9 per cent. to 27 per cent. ash, and which may be considered as covering practically the whole range of the merchant coals. It is frequently stated in the literature of this subject that with high ash anthracite it is necessary to apply a correction for unburned carbon. Under the conditions which usually obtain, this statement is undoubtedly true, and while it is known that an error is ever present, the methods suggested for its correction are of but doubtful value. Such methods include the weighing by difference of the unburned carbon, and the mixing of the coal to be burned with a smaller quantity of a substance of relatively high calorific value. This well-known method has recently been brought forward by Palmenburg as an original solution of this troublesome question. While this method will doubtless give accurate and concordant results, it is only with the greatest care and skill on the part of the operator that such a desirable issue can be expected. The writers have found that with this method the bituminous coal underlying the anthracite is rapidly raised to a high temperature, and that the large volume of gases thus produced are likely to project small particles of the anthracite out of the nickel capsule and thus permit them to escape combustion. Thus, after combustion it is no uncommon thing to find small particles of unburned coal upon the floor of the bomb.

Another source of error worthy of attention is that a greater error is incurred in weighing a small quantity of a coal of high heating value than in weighing a large quantity of coal of low heating value, and that this whole error in weighing is calculated as error in the heating value of the anthracite. Thus the errors in weighing and sampling in both the coal and its kindler are concentrated as error in the heating value of the anthracite. Moreover this error is multiplied $1\frac{1}{4}$ times as .8 gram of anthracite is taken instead of 1 gram. It is to be understood that these errors are generally small but they are avoidable.

Table 1 shows a few determinations by the method of the addition of a kindler compared with a determination by our routine method.

TABLE 1

Number	Per Cent. Soft Coal	British Thermal Units	Asbestos Method British Thermal Units
C-2241	30.31	10,440*	
C-2241	31.02	10,690*	10,740
C-2241	32.68	10,720*	10,770
C-3022	31.37	9,860*	10,010
C-3022	30.20	9,920*	10,040
C-2300*			14,800
C-2300†			14,850

* Poor burn.

† Soft coal used as kindler

A total of approximately 1 gram of the anthracite and kindler was used for each determination.

When first the Atwater calorimeter was applied to the determination of the calorific value of anthracite in this locality the usual difficulties were encountered. Upon observation it was noted that while the upper or exposed surface of a high ash anthracite might be completely burned to ash, the lower stratum or that part in immediate contact with the nickel capsule would in the vast majority of cases be completely unconsumed. Thus it would seem that the real cause of the incomplete combustion was the chilling of the coal by the rapid conduction of heat through the nickel capsule and heavy platinum wire.

The thermal insulation of the coal from the nickel capsule was then tried with most satisfactory results. This insulation was brought about by lightly tamping into the bottom of the capsule a layer about 3 millimeters thick of soft previously ignited asbestos. By this slight modification it is possible to burn completely and without difficulty coals containing as much as 40 per cent. of ash. The coal after burning leaves the ash either as a porous mass or vitreous globule. In either case the residue is free from unburned carbon as is proved by its failure to lose weight when dried and ignited. Briefly the procedure is as follows:

A nickel capsule 15 millimeters in height by 25 millimeters in width is chosen and a fair sized pinch of soft thoroughly ignited asbestos is placed in it. This asbestos is then slightly tamped in place with some blunt instrument such as the butt end of a fountain pen. This mat of asbestos may be readily formed with a pin so as to form a concave depression, with the center, perhaps 2 millimeters lower than the edges. The mat at its thinnest point, its center, should not be less than 2 millimeters thick. The coal, which should at least pass a screen of 80 meshes to the linear inch, after weighing in counterpoised scoop or bottle is then poured into the capsule, which is placed in the bomb, and the usual routine of combustion followed, except that a pressure of oxygen of 25 atmospheres is used.

It will be seen at once how slight is this divergence from the usual routine. The increased accuracy to be gained is not so obvious. To test the accuracy of the determinations by this method we calculated from the determined calorific value of the coal, the heating value per pound unit of coal by the formula of Parr & Wheeler.

This scheme has been found admirably adapted to such a purpose, for though the heating value per pound unit coal of anthracite from different localities may vary widely, that from the product of the same breaker will adhere more closely to a mean, an exception being an occasional intermixture of badly weathered coals with the usual freshly mined material. A few of these results, given in Tables 2 and 3, may not be out of place as illustrative of these statements. It should be noted that these results are taken from the daily routine and are in no case the result of work performed with a view to future publication.

TABLE 2

Colliery and Information	Per Cent. Moisture	Per Cent. Volatile Matter	Per Cent. Fixed Carbon	Per Cent. Ash	Per Cent. Sulphur	Heating Value Per Pound Dry Coal in British Thermal Units	Heating Value Per Pound Wet Coal in British Thermal Units (Parr & Wheeler)
Gilberton Boiler Tests.....	7.64	5.44	68.98	17.94	.81	11,950	15,160
	9.96	3.34	60.37	26.33	.83	10,400	15,320
	9.87	3.52	62.05	24.56	.69	10,760	15,280
	6.61	4.79	62.94	25.66	.78	10,640	15,170
Hammond Boiler Tests.....	7.78	4.32	64.23	23.67	.71	11,010	15,270
	5.21	5.23	68.26	21.30	.45	11,400	15,070
	5.99	5.28	65.73	23.00	.54	11,260	15,190
Wadestown.....	9.27	5.38	71.21	14.14	.65	12,390	14,920
	10.49	4.94	66.11	18.46	.65	11,600	14,950
Boston Run Tests.....	4.61	4.41	60.29	30.69	.80	9,720	14,940
	9.20	2.94	58.00	29.86	1.26	9,510	14,830

As these coals were fired wet, the samples were preserved in air-tight containers, the moisture being determined prior to grinding. When reviewing Tables 2 and 3 it is understood that the formula by which the values were obtained is but an approximation having no absolute accuracy, and that the errors of the proximate analyses as well as those of the actual calorimetric determination are reflected in the heating value per pound unit of coal.

TABLE 3

Size of Coal	Per Cent. Moisture	Per Cent. Volatile Matter	Per Cent. Fixed Carbon	Per Cent. Ash	Per Cent. Sulphur	Heating Value Per Pound Dry Coal in British Thermal Units	Heating Value Per Pound Unit Coal in British Thermal Units (Parr & Wheeler)
Stove.....	1.70	6.45	79.33	12.52	.57	13,410	15,560
Chestnut.....	2.10	6.38	76.14	15.38	.54	12,830	15,170
Pea.....	2.51	7.20	71.14	19.15	.56	12,230	15,540
Buckwheat.....	1.39	6.45	73.86	18.30	.58	12,490	15,640
Rice.....	2.13	6.69	71.40	19.78	.57	12,290	15,750
Barley.....	2.44	6.90	69.80	20.86	.50	12,120	15,780
Broken.....	2.95	5.57	80.75	10.73	.55	13,660	15,530

It may be well to note that the above results were obtained with the Atwater calorimeter, the water equivalent of which was determined by burning samples of naphthalene and hippuric acid as recommended by Atwater in his original article. (Journal American Chemical Society, Vol. 25, page 659)

Although having no direct bearing on the method, it may be of interest to state here, that this particular Atwater calorimeter has been slightly modified by us for convenience in manipulation. The screw cap, socketed for a spanner on the original apparatus, has been replaced by a screw cap bearing a hexagon head. Thus, by substituting a box wrench for the original spanner the annoying tendency to slip has been removed. The stirring motor together with an upright some 42 centimeters high, has been mounted upon a piece of oak board, free to move upon the calorimeter table. This upright supports a walking beam, one end of which is connected by a driving rod direct to the crank of the motor; while the other end of the beam may be thrust into the ring of the stirrer, thus giving the stirrer a positive movement much to be preferred to the more or less uncertain motion imparted to it by the usual string and pulley device.

來 來

Calcium Chloride as Dust Preventative

Referring to the use of calcium chloride for laying dust in coal mines, Mr. Caldwell Harper says that calcium chloride has already been tried for a similar purpose, and failed. In 1875, Doctor Dammer, of Berlin, recommended it for freeing roads from dust, but the roads treated with it remained as dusty as ever. The reason it is expected to lay dust is that it is hygroscopic, but because it is hygroscopic it readily becomes a solution, and when in solution it is easily decomposed. Ferrous sulphate soon decomposes it, so do dilute sulphuric acid, magnesium sulphate, copper sulphate, sodium carbonate, potassium oxalate, sodium phosphate, ferric aluminate, and many others. Mr. Belger, of Newcastle-on-Tyne, in the course of his researches on the ankylostoma, found that a 25-per-cent. solution of $CaCl_2$, poured on a sample of crushed rock from the bottoms of three different mines at 25° C., lost 85 per cent. of its $CaCl_2$ in 48 hours. Even while it remains undecomposed and hygroscopic, it may do more harm than good. For when only a little moisture is present, the $CaCl_2$ may absorb it all and leave none to lay the dust. Indeed, it is to produce dryness that laboratory chemists put it inside the cases of their balances. It is also stated that calcium chloride harms iron and steel only a third as much as plain water does. This is doubtful. Water gives iron a coating of oxide which serves as a partial protection against further oxidation. Calcium chloride forms iron chloride, which does

not accumulate in this visible way, but weakens the iron quite as much. The effect of the chlorides is illustrated by the fact that iron disappears as fast on a sea beach as on a river side. It is also doubtful if calcium chloride would be harmless to miners. It has a drying and irritating effect on the skin, especially the perspiring skin, and it would hurt the blisters which mine ponies often have above the heel. It might, however, be useful underground for another purpose—that of making wood less inflammable.

來 來

Chocks for Chain Hauls

On hook-chain hauls there is danger of the hooks giving way through either the link or the hook breaking. On single hook chains this is more apt to occur than on double hook chains, and when it does, if there be no chocks, the car runs back, breaking off the other hooks or causing a wreck. In case the pitch is not steep and no wreck occurs from the car running back and striking another car coming up, there are nevertheless grave chances of the car axle at the hook being bent, or the hook injured. To avoid this, the Philadelphia & Reading Coal and Iron Co. introduced the chock block shown in Fig. 2, which, in a modified form, has been adopted on scenic railways in amusement parks. The wooden chock *a* is constructed of such length it may be pivoted to one tie and overlap the rail when in position. To the chock is fastened a 2-inch diameter hickory hoop pole *b* of such length it will reach over two ties and form a spring pole. As the cars go up the incline the chocks, placed at suitable intervals to correspond with the wheel base,

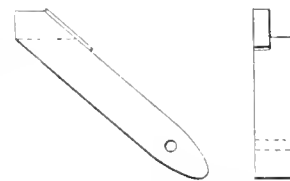

FIG. 1

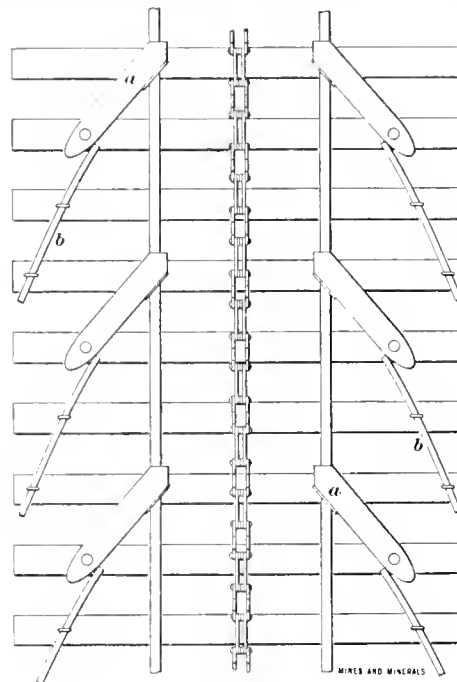

FIG. 2

are pushed to one side by the wheel tread. As soon as the wheel has passed, owing to the spring pole, the chock flies back over the rail; consequently, in case of a hook breaking, the car would not run back more than the length of the wheel base before all four wheels were chocked. While the arrangement is crude it is just as effective and more economical than metal springs. The method of constructing the chocks is shown in Fig. 1. The portion which is hit and pushed off the rail by the wheels, is covered with iron to preserve the wood from wear.

Appliances for Preventing Accidents

Guards and Automatic Devices to Render Impossible Many of the Common Accidents

By Stephen L. Goodale*

A number of signs and notices posted at various parts of the properties of the H. C. Frick Coke Co., to provide for the safety of their employes and others, were described in the August issue of MINES AND MINERALS. This article is descriptive of a considerable number of devices and appliances adopted and in use at these plants to prevent accident. "An ounce of prevention is worth a pound of cure," might be written for this case "A pound of prevention is better than a ton of cure." Many of these devices for the promotion of safety have been developed at the various Frick mines. A number also are mentioned which are not peculiar to this company, but are more or less generally in use; such, for instance, as railings about open shafts, guard cases over exposed gearing, and others. The purpose of this paper is to present, as nearly as may be, all the safety devices now in use by this company, so that in general no mention is made as to where the different items were first developed and introduced, or which are peculiar to these mines. It is hoped that the enumeration and description presented will promote the cause of industrial safety and lead some concerns, whose works are not now as safe as they might be, made with a little effort and money, to "aute up," to use a phrase which will be understood.

Machinery Guards.—In the machine shop and other places where men must work about gear-wheels and where there seems to be danger of clothing being caught by the teeth, such gear-wheels are covered by heavy sheet-metal cases; for instance, on the turret-head toothed pinions of the lathes in the shops, Fig. 1; over the reduction gears from the motor to the conveyer in the coke-drawing machine; over all gears (a single large case) of the pipe-threading machine. These guards are all made substantial and strong, so that they offer ample protection in case of a man falling or stumbling heavily against one. The emery wheels, Fig. 2, are covered over nearly the whole top of each wheel with a heavy cylindrical sheet-metal case, so that if one should break, which happens occasionally because of the high speed, the pieces of emery could not fly.

Over the top of the circular saw, Fig. 4, is a narrow guard held up by an iron bar the thickness of the saw, and in line with it projecting from the table behind the saw. This can be raised or lowered according to the size of saw being used and the thickness of piece being sawn. The band saw, Fig. 3, is entirely enclosed, top and bottom, and except only that short piece where the work is being done. This case is made of light matched stuff, and together with the guard

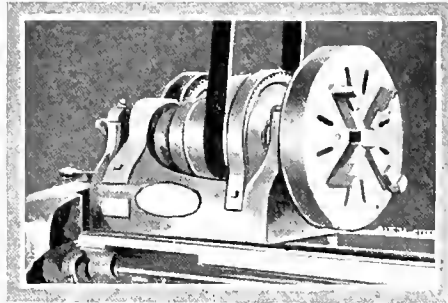

FIG. 1. GEAR GUARD

over the circular saw constitute two of the most important shop safety devices. A danger sign also is sometimes tacked on the band-saw case to draw attention to the danger of a saw breaking and its pieces being thrown across the shop.

High-speed belts are cased in when they are so located that there is danger of a person being caught by them. It may not be amiss to call attention to the regulation that machinists are required to wear whole and not ragged clothing, and that long neckties are not permitted. In certain cases of rapidly turning spoked wheels, practically the whole wheel is encased; open pulleys are sometimes the cause of serious accidents.

A railing is placed about high-speed machinery, and also at places about other machinery which is dangerous, as hoisting drums, and so on.

The Nicholson engine stop is employed at practically all of the Frick company's shaft mines to prevent any accident from overwinding in hoisting. Its application to a hoist is shown in Fig. 5. Without going into the detail of its construction the following may be quoted from a letter of Mr. R. H. Nicholson. The principle of the device is to operate "every hoist, cutting off the steam supply at the main or slide-valves gradually, when approaching the landing or dump, thus weakening the power of the engine and the slow application

of the steam brake acting in unison. It does not depend upon speed requirements, but acts at any speed, no matter how fast or how slow, as the movement of the drum in either direction actuates the stop mechanism at a prearranged time suitable to the hoisting conditions."

At many of the hoists a matched-board partition is set up between the hoisting drum and the engineer with a strip of canvas stretched from its upper edge to the rafters of the hoisting building. Small particles of dust lodge on the hoisting rope and are thrown off when hoisting, and this narrow partition is to prevent such dust from getting in the eyes of the engineer.

A gate is set at the end of any switchboard carrying high potential lines so that persons cannot conveniently get to the uncovered conductors at the rear of the board; this gate is kept locked. Rubber mats are stretched along the front side of the switchboards. The transformer station, at mines like the York Run where electric haulage is used, is enclosed by a strong fence, and the transformers are set on a platform above the ground so that the danger of any accidental contact with

high-tension wires is eliminated for employes or others about the plant.

Any electric switch may be locked, either by means of a wooden block that can be locked on the knife edge, absolutely preventing the switch from being thrown in; or the switch may be placed in a heavy sheet-metal box; the key in either case being carried only by the electrician or whoever is working on the line so that such a man will be safeguarded against any inadvertent closing of the switch. As this switch lock might well be applied in electric work very generally, drawings for the device are shown in Fig. 6. At the coking plants making

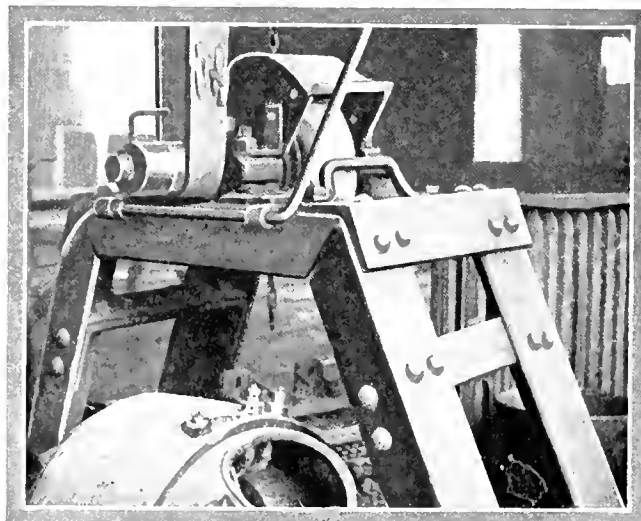

FIG. 2. EMERY WHEEL GUARD

* Professor of Mining, University of Pittsburg.

use of the waste heat from the ovens for steam-raising purposes, the long waste-heat flue conducting the very hot gases to the boilers has been a source of great trouble. A very high temperature is developed, and instead of the smokiness of the ovens that discharge directly into the atmosphere the gases in the flue are clear and transparent, showing complete combustion, and resulting in a temperature high enough to require silica brick for the lining. These brick sometimes work loose and leave a dangerously thin place in the flue; and a wire fence is placed alongside the flue with large danger signs to warn people from walking along the flue. Directly over the flue are also built at intervals low brick pillars to interrupt walking and also help in keeping people off. This is shown in Fig. 7, as well as the contrast between the smoky ovens beyond discharging into the air and the near row of ovens free of smoke.

When a boiler is to be taken out of service, so that men may work in or about it, a suitable blank flange is inserted in the steam connection, in the blow-off connection, and in the feed-connection, so that in the event of leakage or breakage of a valve the workmen are still safeguarded. These blank flanges are an additional safeguard to the locking device for hand wheels on valves, shown in Fig. 8. It consists of a sheet-steel case of a size to fit over the hand wheel and effectually prevent its being turned. Each boiler steam valve carries the same number that the boiler carries, punched in No. 20 steel and fastened to the valve by suitable clips, so that no mistake can be made in opening steam valves. Whenever a man is working in any boiler a large sign is hung on a tripod in front of the boiler "Man in Boiler." Each water gauge is provided with a semi-cylindrical full-length cover, and when a new glass is inserted this is used to protect the workman from danger of breakage of the glass in heating when the steam is turned on, and when the glass is hot the guard is simply swung around out of the way. The boilers blow off into a large underground cistern covered with a heavy cast-iron grated lid, sometimes a number of boilers through one line into such a cistern, in which case the flanges and cases above described are used on the blow-off as well as steam and feed lines, and sometimes each boiler blows through a separate blow-off line from the boiler. There is a continuous pathway over the tops of the

boilers from one end of the bank of boilers to the other with continuous hand rails along the sides for the whole distance, so that in any case of escaping steam a man, even without being able to see, can guide himself safely along the pathway. This has been of actual service in a number of instances of minor blow-out or leakages.

Four-stage compressors are used to supply air at 800 pounds for the mine air locomotives. The presence of oil in the high-pressure cylinder sometimes causes an explosion if the temperature runs too high, due to the compression of air. A safety device, consisting simply of a fusible plug set in a small valve inside the discharge pipe from the high pressure prevents this by melting before the dangerously high temperature is reached, and the engineer is called by the whistling of the escaping air.

With the shaft-gate locking device shown in Fig. 9 it is impossible to open the gate in the railing about the top of the shaft unless the cage is there. The latch can be raised only by a system of levers operated by a handle extending through the fence just beside the gate; and it is only when the cage is in position

at the surface that the proper bearing is afforded to the levers so that the latch can be lifted. On the shaft framing at the ground level is fastened a horizontal plate—an L-shaped lever turns about a pin in this plate. The lever arm is ordinarily back from the shaft out of the way of the cage, but when the cage is present one arm may be turned so as to bear against the side of the cage; the other arm being connected by a straight rigid link to the lower end of an upright lever, to the upper end of which is fastened the rod and handle to operate the gate latch, and which ordinarily when the cage is not present turns about a pin held by a heavy weight about 10 inches from the lower end. If now the upright lever is pulled with the cage away the L-shaped arm is simply turned forward and one arm extends out over the shaft; but if the cage is present the L arm can turn only until it hits the side of the cage when the lower end of the upright lever is prevented from further movement by the rigid link and the weight is lifted by any further pull. The gate latch is connected by a simple system of levers to this weight, holding the gate locked except when this weight is moved by the lever.

Only When the Cage is Present.—It is proposed to connect this device also to operate a car stop so that it will not

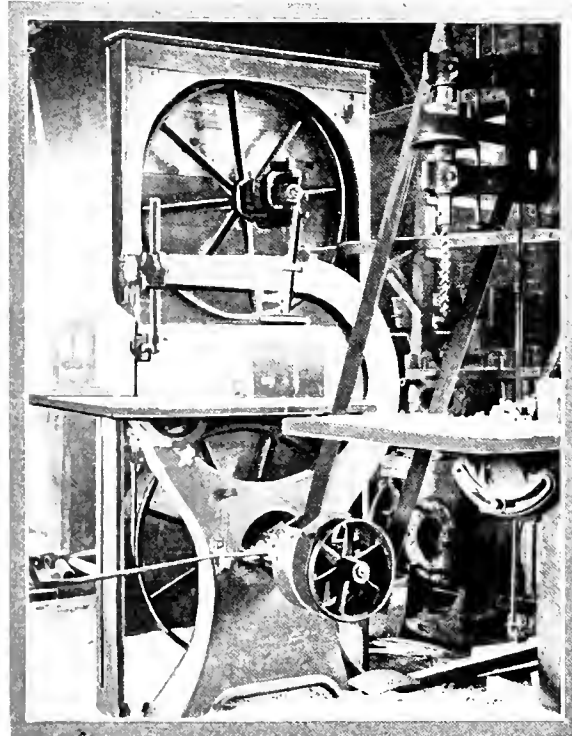

FIG. 3. BAND SAW GUARD



FIG. 4. SAW GUARD

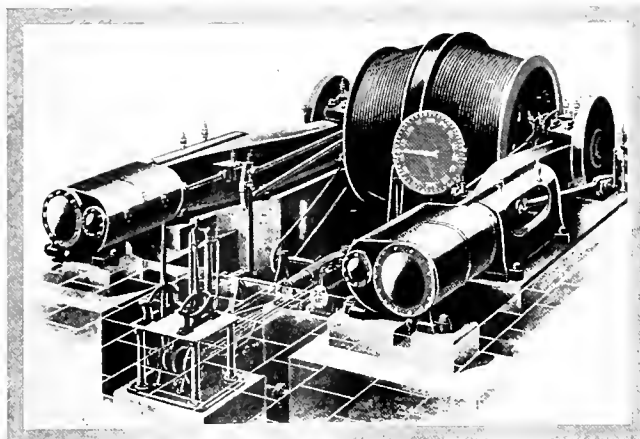

FIG. 5. ENGINE STOP

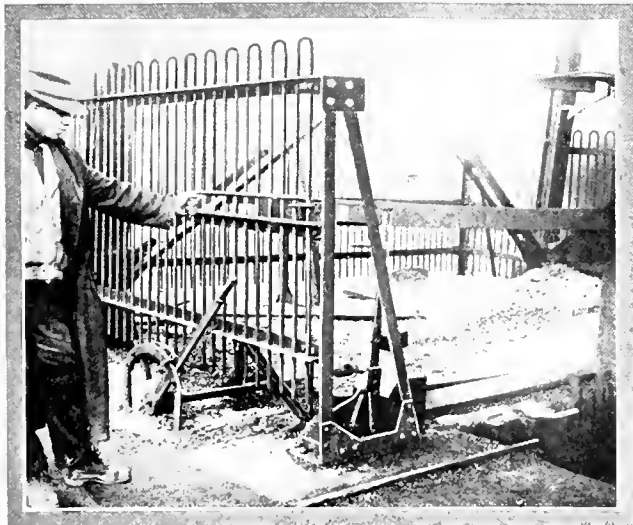

FIG. 9. SHAFT GATE LOCKING DEVICE

The mine superintendent is required to look over reports and initial them daily, thus signifying that he has examined the reports made and entered by mine and fire bosses in the regular books. This insures that the superintendent shall keep constantly posted on the reports made by those under his authority.

Every month a list is made up showing all accidents which have been reported from all mines belonging to the company. These lists are classified and arranged under various headings and copies sent to all superintendents to bring to their attention the causes of accidents so that by exercising foresight and care they may be able to avoid similar accidents in the future.

The habitations provided for the employes are large comfortable double houses for two families, and when possible sufficient space is provided with each house for a small garden. At some mines the employes are encouraged by the offer of prizes to keep the place in a fine condition and to have the best garden possible, so that as a rule the towns are neat and attractive.

No Sunday work is done if the work necessary can be done on any other day or at night. On Sunday only the firemen on the boilers, pumpmen in the mine, hoisting engineer day and night, and night watchman do work.

The provisions of the United States Steel Corporation and Carnegie Pension Fund apply to employes of the H. C. Frick Coke Co.

At each mine there is either a small building or a room, warmed and lighted and provided with hot and cold running water, and equipped to give the first attention to those who may be injured accidentally. The equipment includes a Johnson's first-aid cabinet, an army stretcher, an operating table, towels, rubber blankets, linseed oil, bandages, and so on. The stretchers are covered with canvas and differ from an ordinary one only in being provided with short legs made of a loop of $\frac{1}{4}$ " x 1" iron so as to hold the stretcher about 6 inches above the ground and provide runners on which the stretcher can be

dragged along while carrying a man if necessary. Ambulances are provided with covered tops and have stretchers hung from springs attached to the sides in much the same way as in the mine cars shown in Fig. 11. The hospital equipment is duplicated underground.

All the mines have either a number of men trained in first-aid to the injured, or else a number of squads now receiving the training; for instance, the Continental No. 1 has seven such squads undergoing training. They practice each Tuesday night under competent instruction, and every second week the company physician gives special lectures on first-aid work. The men take great pride in doing this work nicely, and many of their bandages would do credit to a trained surgeon.

A small library containing books on mining and allied subjects is usually available and is appreciated by some of the more ambitious men.

來 來

Oil and Coal in Honduras

About four years ago, writes Consul Arminius T. Haeberle, of Tegucigalpa, while search was being made for silver in the Guare Mountains in the district of Rosario, Department of Comayagua, indications of petroleum were discovered about 21 miles from the town of Comayagua. A gulch in the mountains exposes a stratum of rock about 2 miles long, samples of which were examined and stated to be bituminous limestone containing oil, either with petroleum or asphalt base; this has not been definitely ascertained. The land was denounced some time ago, but only recently a company was formed and a concession granted by the government to carry on the work of searching for the exact location of the oil.

Indications of coal are said by the United States Consul to exist in many parts of Honduras, in the Departments of Tegucigalpa, Yoro, Choluteca, Comayagua, and Valle. Until now no investigation has been made as to quantity, nor has the quality been carefully examined. There is an outcrop in the Department of Choluteca, samples of which, taken from a vein about 45 feet wide, are said to be good. Also in the Department of Paraiso, coal has been found which is said to contain about 70 to 75 per cent. of carbon.

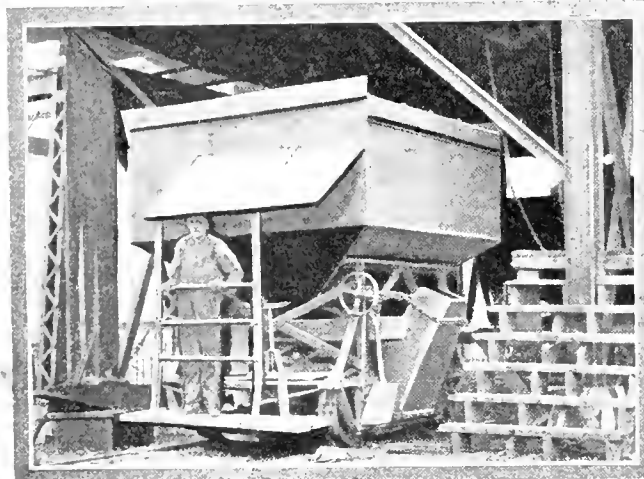

FIG. 10. GUARD FOR LARRY DRIVER



FIG. 11. HANGERS FOR STRETCHER IN MINE CAR

Coal-Dust Explosions

Conditions Necessary to Sustain a Dust Explosion. The Method by Which Air Is Supplied

By John Verner*

In a letter published in the July issue of MINES AND MINERALS, Mr. C. M. Young, Associate Professor of Mining Engineering, University of Kansas, expressed the belief that certain errors of fact were contained in the article on "Coal-Dust Explosions" which appeared in the May number of MINES AND MINERALS, errors which he thinks should not be allowed to go without some correction.

Mr. Young believes it to be an error to accept the conclusion that the manner and amount of the air supply constitute the paramount factor in a dust explosion. He also considers as insufficient the data submitted to sustain the conclusion that the dust is injected into the flame by a strong air draft directed toward the advancing explosion, and he states what he assumes to be the facts as follows: "I wish to emphasize the statement that the conditions necessary for an explosion are, first, an explosive dust; second, the suspension of a sufficient quantity of it in the air. The error in the author's conclusion that explosiveness depends largely upon the quantity of air present, lies in the fact that in most cases there is too little dust present to be explosive. In other words the air is greatly in excess of the required amount. The dust present does not furnish sufficient heat for sustained combustion; therefore there is no explosion. It is only when considerable quantities of dust are suspended in the air and when this dust is of readily combustible character that an explosion occurs. I wish to take issue with the conclusion that the quantity of air rather than the quantity of the dust is really the measure of the magnitude of an explosion."

Professor Young's criticism is welcome because it directs attention to that phase of dust explosions which so far has had but little attention and that must be cleared up before the final solution of the problem can be reached. Mr. Young objects to Haas' conclusion, quoted by me, that "the quantity of air rather than the quantity of dust or coal is really the measure of the magnitude of an explosion." The conclusion is based upon the fact, as stated by Haas, that air is a necessary element for an explosion and that coal and coal dust are always in excess and the amount of gas that could be given off is incalculable. The following examples will tend to show the correctness of the conclusion. There were no better ventilated mines anywhere than the Monongah mines at the time of the explosion; they were provided with a rather unusual number of openings connecting them with the surface and in consequence draft facilities in these mines to promote and sustain combustion were of a very high order, yet Professor Payne in giving the results of his investigations of this explosion stated that while under the extremely favorable conditions named the explosion was one of the most violent on record, it would have been more destructive "had there been sufficient air to support combustion, in which case the almost incredible pressure of 21,600 pounds per square foot would have been reached with a temperature of 4,683° F."

Peckham and Peck in their experiments with inflammable dust found that the making of holes in the testing box, through which the air could enter, in all cases increased the force of the explosion in the box.

To show the opposite effect, I refer to the Illinois Mine Inspectors' Report regarding the dust explosion several years ago in Mine 18 of the Dering Coal Co. After the main explosion, secondary explosions occurred at intervals of about 2 hours, but they ceased as soon as the fresh air supply and draft was prevented from reaching the fire by the sealing of the shafts.

If Mr. Young's emphatic conclusion is correct that the only

* State Mine Inspector, Chariton, Iowa.

conditions necessary for an explosion are, first, an explosive dust; second, the suspension of a sufficient quantity of it in the air, the danger from dust explosions should increase with a mine's extent, for it may be reasonably assumed that the longer a mine is worked and the more extensive it becomes, the greater the total dust accumulation in it and the better the chances for its suspension in large quantities, but the Kansas mine inspector's reports show that the older and more extensive mines in that state were fairly immune from dust explosions, although such explosions may have occurred in them while they were new, and the reports further show that these explosions have been confined almost entirely to new mines. Kansas is not the only coal-mining state where this was found to be the case. It is a fact of general application. In Iowa, for instance, the record of the last 35 years shows that in all the mines, in which explosions occurred while they were new, the danger from their reoccurrence decreased with the increase of the distance from the mine openings to the working faces and with no perceptible material change in other conditions. How is this fact to be reasonably explained if not by the logical conclusion that the greater and more readily available air supply and the better draft facilities in the new mines promoted and sustained combustion with explosive results, while in the older and more extensive mines with longer air-courses, perhaps more or less obstructed by falls or otherwise, the amount of air supply and the draft facilities were insufficient for that purpose?

Dust explosions have originated in the interior of extensive mines, but in every instance where this occurred, it was found that the mine afflicted was provided with an exceptionally large air supply and with superior draft promoting facilities.

As Mr. Young questions the sufficiency of the data given in the article tending to prove that the dust is injected into the flame, by an air draft of greater or less force traveling opposite to an explosion's advance, I shall submit supplementary evidence that may be more convincing. There can be no better evidence regarding this matter than the testimony of men who were caught in explosions, observed what occurred and escaped to give their experience. It will be noted, that although these men were in mines far apart, unlike in conditions, their evidence regarding air and heat movements is exactly the same. In the article reviewing the second Lick Branch explosion, I mentioned the testimony of Mine Foreman Bowers relative to an inrush of cold air of great force followed immediately by an outrush of flame and hot gases from the inside. After the Cokedale explosion "the two survivors testified that they first felt a rush of cool air in the face which blew out their lights and which was instantly followed by a hot blast from inside which knocked them down." Last February a small explosion occurred in an Iowa mine. The shot firer, a cool headed and experienced man, felt the initial shock and threw himself on the floor. He saw the flame, confined to the upper part of the entry, coming toward him and at the same time felt an inrush of air behind him that was strong enough to pick him up bodily from the floor and hurl him some distance toward the advancing flame. He was severely burned but made his escape.

The testimony of these men shows, first, the probable method of air supply to sustain combustion during an explosion's progress, second, the possible intensity of draft directed toward the advancing explosion, and third, the probable manner in which the dust is conveyed to and injected into the flame.

Professor Young admits the necessity of extremely rapid combustion of the dust to produce explosive results, but he rejects the natural process by which this can be accomplished, for he expresses his emphatic belief that the rate of combustion is not determined by the amount of air and draft supplied and that therefore the laws governing combustion have no application in a dust explosion. Until the proof of this is furnished it may be well to still continue to accept as true Haas' conclusion that "the quantity of air rather than the quantity of dust or coal is really the measure of the magnitude of an explosion."

Victor Electric Safety Lamp

Methods of Charging Batteries and Handling Lamps. Increased Output from Better Light

By Mark O. Danford*

An interesting test of electric safety lamps was made at the Toller mine, of the Cedar Hill Coal and Coke Co., at Tollerburg, Colo., the past year. The lack of efficiency of the company men, on account of using the flame safety lamp, led the management to investigate the electric safety lamp, as the mine is gaseous and safety lamps are a necessity.

After experimenting for several months, Mr. Victor Patton, electrician at the plant, designed a lamp and battery which he calls the Victor electric safety lamp, which has been patented. This lamp has been adopted by the Cedar Hill Co. and furnished to all underground men at the Toller mine.

The first trial was made about a year ago, when five lamps were issued to the drivers, and the first day that they were used, with the same number of men, drivers and mules, the production was increased 125 tons. All other conditions were equal, the mine working every day, and no stored loads were in the mine the day the test was made. In fact it had been a problem to gather the coal, and considerable dissatisfaction was felt by the miners on this account. Thus the efficiency of each driver was increased 25 tons, with greater safety in handling his trips, spragging cars, etc.

Next the lamps were issued to the tracklayers and it was found that the work could be done with one man that had formerly required two. With the flame safety it requires one man to hold the lamp while the track-layer works and even then the light is insufficient. The electric safety lamp is at all times on the cap and the light is sufficiently strong to make the work as advantageous as with an open light. The same condition was found applicable to the timberman, and one man could do the work of two in this line.

As fast as the lamps could be manufactured they were issued to the miners and now all are equipped with electric lamps. By this installation the efficiency of each miner was increased from 5½ tons per day per man to 6½ tons per day per man. It is well known how hard it is to interest an old and experienced miner in any new device that he is not thoroughly acquainted with, yet it is gratifying to see how quickly they adapted themselves to the new electric safety, and the best boosters for the lamp are the miners themselves.

Aside from the increased efficiency and financial benefit to the miner the best feature of the lamp is its possibility to test the roof conditions. The miner does not now have to depend altogether on sound in testing the roof, but the slips and cracks are at all times visible, whether the roof be 1 foot or 6 feet above his head. This added degree of safety is probably the most appealing feature of the lamp.

The lamp is so made that all connections are accessible to repairs. The back part of the lamp is fitted with a lug on each side that fits into a slot in the front or reflector part of the lamp.

By a simple turn the two parts are separated and the connections are exposed and ready for repairs should any be necessary. The globe is protected by a glass crystal fastened into the outer casing with a spring ring. The reflector is of nickled tin and acts as a circuit-breaker in case a fall should crush the outer casing, for the instant the outer casing touches any part of the reflector the circuit is broken and the lamp goes out, eliminating any spark in case the globe should be broken. The lamp has a hook at the back that fits any style of pit cap. Insulated lamp cord connects the battery to the lamp. One-half candle power tungsten globes are used and by the aid of the reflector cast a strong light. The miners usually carry the battery in a leather pouch swung from straps so as to hang under the arm, as shown in Fig. 1. This is the most satisfactory way to carry the battery, yet many have made a simple leather pouch with a slot cut in the back through which is passed the belt. The battery then hangs similar to a cadger of oil. One dollar per month is charged each man for upkeep of lamp and recharging of battery. This is the same as was charged for the flame safety and is less than it would cost per man to furnish open light.

As the success of the lamps depends greatly upon the recharging of the batteries several experiments were made before a suitable charging rack was evolved. This rack shown in Fig. 2 is made of 1 in. x 10 in. uprights with a run of 7 inches and rise of 10 inches. A 2 in. x 2 in. piece connects the uprights. Pieces of spring brass 1½ inches wide and about 4 inches long shaped like an "U" are screwed to the 2 in. x 2 in. with scant distance between to receive the battery. The poles of the battery rest in small grooves in the spring brass. The current is taken in at the right side, through the wire *a*, passed through the resistance lamp *b* to the first brass connection, then through the battery *c* to the next brass, and so on across the row of batteries to the left side of the rack where connection is made to the negative wire *d*. This rack can be made any size and to hold any number of batteries, the current being regulated to the number of batteries being charged at one time. The best results at Toller are obtained by charging at the rate of 1 ampere per hour



FIG. 1. VICTOR ELECTRIC LAMP

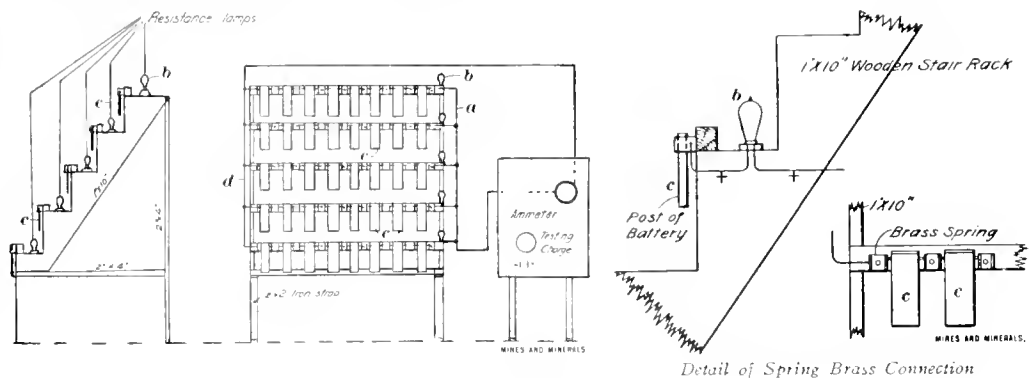

FIG. 2. CHARGING RACK

for 9 hours. It requires direct current to charge batteries and as the power at Toller is alternating current, a small generator was made in the shop and is driven by an inner belt on the shop motor. The battery casing is made of hard rubber and when completed and charged ready for use weighs 1 pound, 6 ounces. The life of the elements of the battery should be about 2 years, depending upon the care used. The battery should never be set aside without charge, as the acid without the charge sets up chemical action that destroys the positive plate. When the batteries are fully charged they are tested

* Danford & Sanderson, Mining Engineers, Trinidad, Colo.

at the switchboard and they should read from 50 to 60 amperes, 2.9 volts, and when so charged and using $\frac{1}{4}$ candlepower globe, burn from 16 to 21 hours. One candlepower globe will burn just half as long.

A rack of lockers has been constructed in the lamp shanty equipped with padlocks. The lockers are numbered on the front and back to correspond to the check numbers of the men. The lamp and battery are placed in the lockers from the rear which is left open, as shown in Fig. 3. The miner is furnished



FIG. 3. LAMP LOCKERS

with key to his locker and takes lamp and battery out in the morning, returning it at finish of shift. The lamp tender takes the batteries from the lockers, fills them with solution and hangs them on the charging rack. While the batteries are being charged he goes over all lamps, making any repairs necessary. After the battery has been charged they are drained of the remaining solution on to a board constructed for that purpose, tested at the switchboard, and replaced in the locker with the lamps, ready for the next shift. Each lamp is numbered with a corresponding number on the locker. In this way it acts as a check system for the men in the mine, and the tender can at all times account for all men in the mine in case of an accident. One man can easily take care of 500 lamps.

The cost of upkeep for 500 lamps is as follows:

Bulbs should burn 650 hours or for 500 lamps, say 3 bulbs per day at cost of 33 cents each.....	\$.99
Lamp cord renewal for 500 lamps, one per day.....	.30
Broken lens.....	.10
Cost of charging batteries is 3 watts each=1,500 watts for 500 batteries, say 3 horsepower per hour, at 1 $\frac{1}{2}$ cents per horsepower hour=5 $\frac{1}{2}$ cents per hour for 9 hours....	.47 $\frac{1}{2}$
One lamp tender.....	2.75
Three quarts of solution.....	.10
Total per day for 500 lamps.....	\4.71\frac{1}{2}$

This shows a trifle less than one cent per day per lamp.

The lamp has been tested in all mixtures of fire-damp, and no flame can be produced. It is well to remember that it will not test gas, and flame safeties will have to be used for that purpose by the fire bosses and inspectors.

來 來

Miners in Arkansas

Prof. A. H. Purdue in a report to the Governor and the members of the Geological Commission of Arkansas, says: In Arkansas 79.1 per cent. of the miners are English speaking, 66 per cent. are American born, and 2 per cent. are negroes. American born white make up about two-thirds of the mine crews. Of these 20 per cent. to 25 per cent. are natives of

Arkansas. The other Americans are generally experienced coal diggers from other states, chiefly Alabama, Pennsylvania, Indiana, Tennessee, and Kentucky.

The natives of Arkansas are men used to mines, and those underground are generally young; but of the top laborers three-fourths or more are Arkansas men.

A considerable number of English-speaking miners have studied more or less with the correspondence schools, and the majority of the fire bosses and pit bosses have finished such courses. Through these men the technical knowledge of all the miners is increased. Many of the men are generally interested in geology, ventilation, and general mining problems, and ask intelligent questions whenever the opportunity offers.

來 來

Coal Mining Notes

Anthracite Miners' Demands.—The following is a list of the resolutions presented at the Anthracite Miners' Convention, at Wilkes-Barre: Recognition of the union and check-off; weighing of the coal and payment by the ton; standard price for powder; general increase in wages, averaging from 10 to 20 per cent.; legislative committee; 10 additional mine inspectors; mine bosses to be eligible to the position of mine inspector; mine inspectors directed to enforce the engineers' 8-hour law; that non-English speaking laborers be not permitted to enter the mine; that the chief mine inspector be forbidden to interfere with the present engineers' 8-hour law; the constitution to be amended; that tellers count the ballots 4 days before the convention, and to be in a position to report at the first session.

New Concrete Breaker.—The Lehigh Valley Coal Co., who has in course of erection a mammoth new concrete breaker, between Buck Mountain and Vulcan, are now engaged in the erection of residences in close proximity to the breaker. It is said that the company intends to erect homes for at least 50 families, among which will be those for colliery officials. Work on the breaker and houses will be pushed rapidly, and it is expected that by early fall a thriving village will be placed upon the map where once existed nothing but brush and trees. The site is considered a beauty spot for a mining hamlet, pure air, pure water, and lots of room being among the guarantees of home comfort for those who may call the place home.

The Elkhorn, Ky., Coal Field.—The Consolidation Coal Co., which recently purchased 100,000 acres of coal land in the Elkhorn field, Ky., will be tapped by the Baltimore & Ohio on the eastern end, and the Louisville & Nashville on the other end. To build and equip the railroad branches into the property will, it is estimated, cost the railroads \$30,000,000. The Consolidation Coal Co. is also spending considerable money in developing the property in order to be ready for shipments so soon as the railroads are ready to handle the coal.

Washing Coal for Coke.—Of the 2,069,266 short tons of coal used for coke making in Colorado and Utah in 1910, 1,387,070 tons were cleaned by washing before being charged into the ovens. The washed coal included 836,067 short tons of mine-run and 551,003 tons of slack. In addition to the washed slack, 429,728 tons of unwashed slack and 252,468 tons of run-of-mine coal were used unwashed.

Opening 2,000-Acre Tract.—The Standard Kanawha Coal Mining Co., Quick, W. Va., will develop 2,000 acres of coal, and plans a daily output of 1,200 tons. Pennsylvania capitalists incorporated this company recently with \$200,000 capital.

Pennsylvania Coke in the West.—Frank M. Sylvester, of Spokane, assistant general manager of the Granby Consolidated Mining, Smelting and Power Co., states that if the two trains of coke obtained from Pennsylvania prove that the cost of operating with eastern coke is not much greater than with Crows Nest coke, it will be used in the future.

International Coal and Coke Co., a Spokane corporation, operating at Coleman, Alta., paid its regular quarterly dividend of \$45,000 on August 1, making \$135,000 so far this year and \$796,000 to date. The property is closed on account of the miners' strike in the Crows Nest Pass district.

Underwood Colliery.—The Pennsylvania Coal Co. is arranging to develop a piece of property in Throop Borough, Lackawanna County, Pa., which is underlain by six seams containing, it is estimated, 18,000,000 tons of available coal. These seams are the Big (or Grassy Island), the New County (or Marcy), the Clark, and the three Dunmore (red ash) seams. Three shafts will be sunk; two for taking out coal and one for hoisting men and supplies. The two main shafts will be driven to the lowest, or Third Dunmore seam, with tunnels running across the measures to the seams above. Electricity will be used for haulage and lighting, and it is also planned to use electric mining machines. Electric power will be used to some extent in connection with the pumping. The new colliery will be named Underwood, after the president of the Erie Railroad.

來 來

Lessons to be Learned from Recent Disasters

By John Verner, Chariton, Iowa*

While each mine disaster teaches a valuable lesson it may prove a serious mistake to form final conclusions from any one disaster and prescribe them as remedies for the future prevention of calamities of similar nature; and the possibility of wrong conclusions based upon the investigation limited to one particular case, the necessity and advantage of a comparative study of mine disasters of similar kinds, so the combined lessons of all may be used to bring into harmony apparently discrepant results, can be readily established, as the following will show.

Looking over the report of one of the recent explosions, I found that it ceased on reaching an extended wet area in the mine, and it was assumed that the presence of moisture was the reason why it stopped in that particular place. Turning to the report of another explosion it was shown that the application of moisture and the damp condition of the dust did neither prevent the occurrence of the explosion nor stop it after it had started. Again, looking up another report, I found that the explosion ceased to advance in the presence of an abundant supply of dry coal dust.

The Elk Garden explosion may be taken as an example of the first case. As an example of the second case, I will quote from Miners Circular 3, recently issued by the Bureau of Mines: "In a recent mine disaster in this country, the explosion traveled 1,500 feet along a slope that had been washed down with hose just before the explosion, and even had a wet floor after the explosion. The explosion burst forth from the slope mouth in a great flame and deposited much coked dust on the timbers of the trestle."

To present an occurrence covering the third case I will give the essential part of the report of the mine inspector of New Mexico, relating to an explosion that occurred in the Weaver mine on March 6, 1910: "At the place where the blown-out shot initiated the explosion, apart from the combustion of the crushed coal and dust from the blown-out shot, all conditions were such as to prevent or retard a dust explosion. The explosion traveled outward to the parting on No. 3½ seam, about 500 feet distance. About 15 feet inside of the parting a driver was severely burned, and the two mules he was driving were so badly burned as to cause their death. Indications of the explosion were trivial beyond this point, although conditions were far more favorable for a violent dust explosion than in the locality where the explosive condition was maintained. Where the explosion ceased, at the parting where

empty mine cars are delivered from the surface and loaded cars put on the rope to be transported to the surface, the roadways were covered with coal dust and were quite dry. The area was large, air comparatively fresh, and conditions favorable to the extension of the explosion, but it ceased at this point."

Now, if the first case is considered by itself, it may permit the conclusion that the presence of moisture stops an explosion; if the second case is taken as the sole criterion for basing judgment, there is very strong evidence that the presence of moisture does not stop an explosion; while the consideration of the third case alone might bring the conclusion that the presence of dry coal dust is not a dangerous factor. But when the matter is investigated on a broader scope and a careful comparison of all conditions surrounding recent explosions is made, it appears that the larger lessons so presented show fairly conclusively that the presence of dry dust is a dangerous factor, although not the dominant factor in determining either an explosion's extent or the degree of destructiveness produced by it, and the lesson further justifies the definite conclusion that the moistening of the coal dust as a preventive of explosions is of uncertain value of itself and unreliable to produce the expected results. It is granted that, other conditions being identical, a sprinkled, sprayed, or otherwise moistened mine may be considered less dangerous than a dry and dusty mine, but the margin of possible safety is too narrow and too uncertain to justify the claim, in view of the proofs to the contrary, that a mine can be rendered immune from explosions under any conditions by the application of moisture.

I said at the beginning that it may prove a serious mistake to attempt to prescribe remedies for the prevention of explosions suggested by conclusions based upon narrow and superficial investigations of the subject; and the possible injurious consequences of such mistake become all the more threatening, when men with good intentions, but evidently knowing little of the principles governing explosions, and therefore incompetent to give good advice, can prevail on the members of a state legislature to make mandatory by law the use of an alleged remedy that cannot possibly provide even a small measure of the safety the proposers and makers of the law expected to secure. For instance, in Indiana the law provides that roadways and entries (rooms, cross-cuts, etc., apparently exempt) in any mine shall be regularly and thoroughly sprinkled when they are so dry that the air becomes charged with dust. The law also permits the use of 6 pounds of blasting powder to the shot as a presumably safe charge. A dust explosion occurred in a mine in Indiana, causing loss of life. Suit was brought against the company and the Supreme Court of that state found that "the failure to sprinkle may be charged as the proximate and direct cause of the explosion." I have no fault to find with the decision under the circumstances, but it shows the futility and possible injustice of an extremely faulty law that, in a manner, compels the court to fix the cause of an explosion according to its letter rather than according to the true facts in the case. Such law should be repealed at the earliest opportunity, for it is really a legal obstruction to the promotion of safety, and its possibilities for future harm are great.

From the nature of the experiments recently made in England and France to discover a reliable preventive of dust explosions, it appears that the use of water is not considered adequate or satisfactory in these countries. The men engaged in making these experiments are evidently of the opinion that the use of stone dust in dry mines can subdue an explosion more effectively and quickly than the application of water, but even should the superior effectiveness of stone dust be established beyond a doubt, the present Indiana law would prevent the coal operators of that state from using the proved safeguard, and thus providing an increased measure of protection for the men in the mines, because the effectiveness of the stone dust would be destroyed by the compulsory use of water.

*A paper presented at the Charleston meeting of the Mine Inspectors' Institute of America.

There is no law for compulsory watering of mines in Belgium, yet the Belgian mines, with their great depth, their dryness, and the presence of gas, show a remarkable and pleasing record of freedom from explosions. There should be hesitation about hastily enacting laws in the mining states of this country for the compulsory application of water, because it is not only of doubtful value, but it carries with it a promise of safety that may not be redeemed when the test comes. Case after case could be cited to prove this, and it is only hindering the final solution of the explosion problem to present excuses why the application of water failed to produce the desired effects in this or that explosion, instead of fairly facing the fact that they were not prevented by the method in use, although the method as employed, for instance, in the slope mentioned in Miners Circular 3 of the Bureau of Mines and in the Banner mine in Alabama was as near perfect as man could reasonably be expected to make it.

采 采

Method of Testing Miners' Oil

For purchasing miners' oil, the Consolidation Oil Co.'s (Fairmont, W. Va.) specifications are: The sample, having a density of 24° B. scale or under, is placed in a glass cylinder 1½ inches in diameter and brought to a temperature of 60° F.,

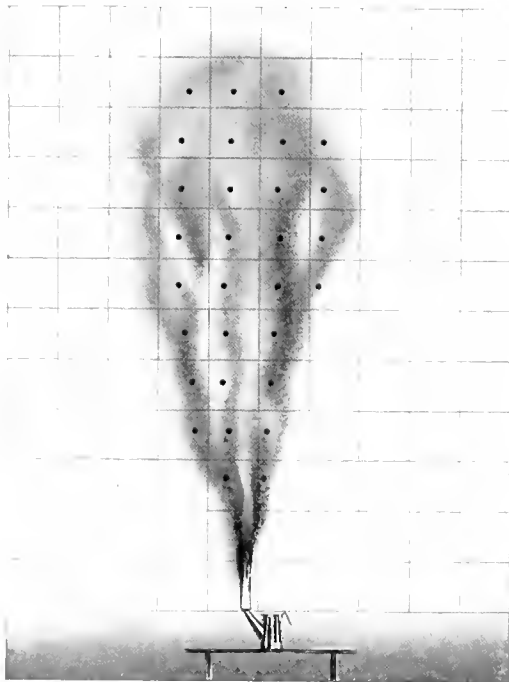

FIG. 1. TESTING OIL FOR SMOKE

as prescribed in the State Mining Law, and a hydrometer, standard Baume, with thermometer combined, is placed in the oil, and after stirring and mixing the oil thoroughly the last line of the scale appearing below the surface of the oil is read.

The flash point is not to exceed 425° F. or to be under 300° F. The sample to be tested is placed in the inner can of a small double bucket, and a thermometer suspended so that the mercury bulb extends just below the surface of the oil. The temperature of the oil is raised by means of a Bunsen burner lighted and placed directly under the bucket. As the temperature rises a lighted match tells when the oil will flash.

To test the congealing point, which should be less than 24° F. or under, fill a medium-sized test tube one-third full of the oil to be tested, and place it in a 500-cubic-centimeter beaker. Pack fine ice and salt around the tube. Place a thermometer in the oil and remove after stirring the oil. When the oil will no longer drop off the end of the bulb, read the thermometer for congealing temperature.

To find the grams of oil burned per minute, which is not to exceed .5 gram per minute, a No. 2 Star miner's lamp is supplied with an 8-inch wick of lamp cotton weighing 2.5 ounces per ball, running 7 threads to a strand made by using four strands. The wick projects ¾ of an inch beyond the end of the lamp spout. The lamp is filled with the sample, lighted and placed on balances, and allowed to burn 10 minutes. The loss in weight is calculated to grams per minute.

The flame height is measured while the lamp is on the balances, the end of the first, fifth, and tenth minutes; the average of the three readings is taken as the height of flame, which should be between 3.5 and 5 inches.

The apparatus used to make the smoke test consists of an electric arc spot light (such as used in a theater), and a curtain of tracing cloth 4 ft. × 5 ft., ruled off in 4-inch squares, and stretched tight on a vertical frame. The spot light is placed 15 feet from the curtain and so focused as to cast a white light or spot over the entire curtain or chart.

The lamp used is a standard No. 2 Star miner's lamp, and the lamp cotton weighs 2.5 ounces per ball and runs 7 threads to a strand. The wick is made of 4 strands and is 8 inches long. It projects ¾ of an inch above the top of the lamp spout when the lamp is lighted, and during the burning period it is not disturbed. The lamp is filled with the oil to be tested and lighted and placed 5 inches from the curtain, between the curtain and spot light, so the shadow of the smoke will be cast directly on the curtain, as shown in Fig. 1.

In the illustration the squares dotted are the ones counted as being covered with the smoke shadow. There being 31 squares, this is the figure representing the oil under test.

After lighting, the oil is allowed to burn for 3 minutes before a reading is taken. At the end of 3 minutes the number of 4-inch squares covered by the smoke shadow are counted. The burning continues for a period of 30 minutes, a reading being taken every 3 minutes. The average of the 10 readings is taken as representative of the smoke of the oil being tested. The figure "30" is the figure for pure cottonseed oil (used as a standard of comparison), and the figure "35," which is the number of squares covered by the smoke shadow, is the limit established, and if the smoke shadow exceeds this number of squares, it is considered objectionable for use by this company.

采 采

Book Review

A STUDY OF THE BLAST FURNACE, by Harbison-Walker Refractories Co., Pittsburg, Pa. This book has been prepared by the publisher for the benefit of the members of its organization. It is considered a digest of the subject in a simple and brief form; nevertheless, the reviewer considers it about as terse and useful a little book as was ever published on the subject of pig-iron manufacture. It supplements the company's "Study of the Open Hearth," and should be in the hands of every practical furnace man who has ambition for advancement. It is divided as follows: Description of Plant, with illustrations of Calder, Foote, McClure, McKee, Roberts, Julian Kennedy, White & Kernan hot-blast stoves; Ores and Their Treatment; Fluxes and Fuels; Burdening the Furnace, and Calculation of Charges; Operating the Furnace; Furnace Reactions, including a discussion on the dry-air blast. The illustrations are excellent, and the book is bound in red leather. In a pocket is a map in colors showing iron blast-furnace districts and iron-ore deposits of the United States. No price is set for this book, and although it has cost considerable to manufacture, it is possible that it may be obtained gratis by those interested in iron blast-furnace practice.

ANNUAL REPORT OF THE DIVISION OF MINERAL RESOURCES AND STATISTICS ON THE MINERAL PRODUCTION OF CANADA, DURING THE CALENDAR YEAR 1909, by John McLeish, B. A., Department of Mines, Mines Branch, Ottawa, Canada.

Profit and Loss Account

Necessity of Considering Relation Between Capitalization and Annual Output of Mines

The importance of proper accounting, both as regards costs and capital account, was treated upon by Neil Robinson, of Charleston, W. Va., at the December, 1910, meeting of the West Virginia Mining Institute, in a paper entitled "Profit and Loss Account," as follows:

The mine managers of the country, as a rule, are men of ability who have accomplished results under difficulties, and who are entitled to honor and profit for the faithful performance of services to the world.

Upon strict analysis it will be found that the majority of our mine managers exercise skill, good judgment, and economy in handling the labor and physical conditions connected with their plants, and deliver coal on board at the tipples at a low and reasonable cost per ton. In all things over which he has supreme control, the manager of today is achieving success and doing his part in the struggle for a satisfactory profit and loss account.

Although the requisite qualifications are possessed and employed by scores of men in the more important districts of West Virginia, the business as a whole may fail to show substantial profit at the close of the year. In this common event, stockholders, particularly those who are non-resident, are disposed to class coal mining as a financial hazard and attribute responsibility for the condition to the mine management.

In a majority of instances this is absolutely unfair and results in withholding from competent officials the credit that is due to them.

Coal mining is a legitimate business that is conducted in response to a public demand, and is entitled to the stability in returns that accompanies the operation of water, light, railway, and other public utilities.

When there is failure to realize profits commensurate with the natural inevitable risks in mining, it is essential that the cause or causes responsible therefor be sought in order that a remedy may be effectively applied.

The unit of measurement for a mine under full development is the average annual production that may reasonably be expected under normal trade conditions. To this tonnage unit all other features should be coordinated, inasmuch as a lack of perfect harmony in the adjustment of capitalization, area, and equipment to production will inevitably lead to financial losses for the company and discredit for the management.

There are elemental laws in mining that cannot be violated without the payment of a penalty.

The prudent manager, who is to be responsible for operations and profits will, at the inception of the organization, submit to his stockholders a concrete plan, based upon his own experience and that of others, that will give the greatest measure of protection to the capital invested during the full life of the plant.

Capital is not well protected if the number of dollars invested, outside of the free land, is largely in excess of the number of tons of coal produced per annum. For instance, an ordinary mine with 150,000 tons production may protect a sinking fund and pay 6 per cent. (9 cents per ton) on stock and bond accounts aggregating \$225,000, but if we double this capitalization and make an investment account of \$450,000 (\$3 per ton) there is a capital charge of 18 cents resting against every ton of coal production—which is more than many of our mines can stand. If, by reason of extra construction costs for deep shafts, long railroad connections, or unfavorable topography, the investment is to be materially increased above the normal ratio to the ton of production, the prudent manager will advise against the undertaking.

A manager who will persistently add to his production cost sheets an allowance for interest on capital invested, will put a stop to many of the ruinously low quotations made by the sales departments.

Many companies are capitalized upon the tonnage they hope to attain, and meet with disappointment through failure to secure the anticipated output. In this connection, it is interesting to study the performance of the mines in West Virginia for the year ending June 30, 1909, as compiled from the records of the mining department.

Production		Per Cent.
Total number of producing mines.....	709	
Number producing over 100,000 tons.....	129	18.2
Total production June 30, 1909.....	41,693,766	
Production from 129 large mines.....	22,248,264	54.4
Total number men (excluding coke).....	58,582	
Number of men in 129 mines.....	26,377	45
Average production 709 mines.....	58,806	
Average production 580 mines.....	33,527	
Average production 129 mines.....	172,624	

MINES PRODUCING OVER 100,000 TONS PER YEAR

Thickness Seam	Number Mines	Tons Production	Average Per Mine Tons	Number Men Exc. Coke	Number Tons Produced Per Employee
3' 5" to 4' 0".....	8	1,167,277	145,910	1,531	762
4' 4" to 5' 0".....	24	3,675,086	153,128	4,772	770
5' 2" to 6' 0".....	34	5,623,093	165,385	6,843	822
6' 2" to 7' 0".....	26	4,502,712	173,181	4,730	952
7' 3" to 8' 0".....	28	5,239,507	187,125	6,591	795
8' 4" to 9' 0".....	6	1,457,113	242,852	1,222	1,192
Over 9' 0".....	3	583,476	194,492	688	848
	129	22,248,264	172,624	26,377	843

From the foregoing table it appears that an average mine in coal running from 4 feet 4 inches to 5 feet, inclusive, producing 153,128 tons per year, will need 198 employees. In an isolated district, tenements, outside of boarding houses, may be provided on the basis, approximately, of 70 houses per 100 employees, but there can never be an arbitrary rule, and each company will find a profit in studying its own conditions and building upon some well defined system. Too many houses are a drain upon capital, and a shortage may hold a mine below its productive capacity.

The profits of a company are derived from the labor performed by its employees, and any impairment in the energy of the individuals engaged in the work will lessen the ultimate income from the business.

Villages located a mile or more from the mine, involving travel through snow and rain, heat and cold; a mountain path badly graded, surfaced, and drained; slovenly, uncomfortable travelways underground—each of these conditions, if allowed, will cause a waste of energy that must be paid for by the company, whether the labor is producing coal under contract or handling it for a day wage. The wise manager will place his men at their working stations in the freshest condition possible for humanitarian as well as economic reasons.

The manager who, to avoid solving a problem, adopts the motto, "The future will take care of itself," concedes that those who are to come after him will have an ability greater than his own. There are very few mining conditions, aside from concealed troubles existing underground, that cannot be provided for at the opening of a mine.

To begin with, there is the question of acreage to be mined from one plant. We must hold that there are certain economical limits in haulage distances beyond which a mine cannot go without undue cost. It is, therefore, a waste of money if acreage beyond the haulage limit is added to a lease and the company must pay a minimum royalty per acre.

When the lease lines are definitely fixed, a careful estimate

should be made to show approximately the number of tons of coal to be won. Divide this estimate by 25—a fair number of years for a mine—and the answer will be the number of tons per year for which equipment should be provided. In some cases, however, there may be reasons for exhausting the coal in less than 25 years. When this condition is presented, economize in construction work and use material that will answer for the life of the mine only. There will be no profit in stone power houses, slate-roof tenements, high concrete foundations, etc., in connection with a mine that is to have a short life. In other words, harmonize every item of construction with the length of time it is to serve—temporary, if the work is to be temporary; permanent, if the service must run many years. But, under any and all circumstances, the best qualities to be obtained cannot be too good for roadways, motive power, and cars.

The purpose of this short paper is to quicken the interest of our mine managers and superintendents in matters that are frequently left to the decision of others. You are given mines to operate that may be so handicapped by over-capitalization, under equipment, excessive royalty guarantees, etc., that dividends to stockholders can never be realized and losses must surely accrue. It is not necessary to enter into details as to the manner in which these propositions shall be handled, but let me urge each manager who is here today to seek for a true balance between the capital invested and the tonnage to be produced. You are entitled to protection for your reputation, and stockholders are entitled to protection for their investments. You will both suffer when a mine, designed by nature for a small tonnage, is given an expensive equipment, or a mine that has great natural advantages is unduly restricted in its outfitting. Strive for harmony between capital account and betterments on one hand, and your actual output on the other, and the profit and loss account at the end of each year will be closed on the right side of the books.

采 采

Sykesville, Pa., Explosion

Mention was made in the August issue of MINES AND MINERALS that an explosion in which 21 lives were lost occurred Saturday, July 15, at Sykesville, Pa. Judging from the conclusions drawn, the statement made concerning non-gaseous mines giving a sense of false security seems not to have been overdrawn in this case.

Sykesville is a small mining town on the Buffalo & Susquehanna Railroad, in Winslow Township, Jefferson County, Pa. At this place there is a shaft 180 feet deep that taps the lower Freeport or D seam. The mine belongs to the Cascade Coal and Coke Co., of Buffalo, N. Y., and is not a commercial mine, the product mostly being converted into coke in 200 beehive ovens and shipped to the company's furnaces at Buffalo. Considering that the mine was opened in 1904, the area covered by the workings is quite extensive, the main haulage road being 9,000 feet long. The mine is worked double entry, room-and-pillar system, and the rapid advancement of the main entries is due to the fact that no pillars have been removed. Approximately 200 men are employed on night and day shifts in the mine, and on the night of the explosion there were 29 men inside, eight of whom, including the fire boss, escaped. The fan, under normal conditions, at 80 revolutions and water gauge of $\frac{3}{4}$ inch, produced 74,400 cubic feet of air per minute. The ventilation was conducted in three splits and returned into a third shaft. The relief doors of the fan were blown open by the force of the explosion, remaining open 15 minutes, as indicated by the pressure gauge. The fan was otherwise uninjured and continued running. All the bodies were recovered within 24 hours after the explosion, and some of them being slightly burned it is presumed that the remainder died from afterdamp inhalation.

On July 18 and 19, Inspectors Thomas D. Williams, Elias Phillips, Joseph Knapper, Chas. P. Byrne, and Chas. P. McGregor, appointed by Jas. E. Roderick, Chief of the Department of Mines, of Pennsylvania, made an official investigation. From the inspectors' report to their chief the following is gleaned: "There was no indication of an explosion at the bottom of the shaft, nor until 4,000 feet had been traveled along the main entries. Near the sixth right entry a door was blown out toward the face. For a distance of 1,200 feet up this entry to a point near the fourth butt entry evidences of an explosion were plainly visible. From the fifth butt to the fifth right entry, and from the sixth butt to the seventh right entry and along these entries, there was no evidence of an explosion, until, 800 feet from the south main entries on the seventh cross-entries, stoppings were found partly destroyed. Along the left eighth main haulage road there were electric wires down and stoppings on the left were blown down in the direction of the airway. In the second butt left, explosive gas was found, and a 6-inch air line broken by the force of the explosion in the back heading second butt, eighth left, or air-course opposite right. The third butt was in a normal state, although some gas was generating. In the fourth right butt some explosive gas was found and compressed air blowing from pipe. Going along the left main entry to the third right butt, a large fall of coal was found and evidence of an explosion that had spent itself with a considerable division of inward and outward force. Farther in the third right butt, fine coal was found adhering to the ribs, and the cars had been charred with flame. There was considerable heat here and evidence of force. A large cavity in the roof, made in the course of mining, was filled with explosive gas and the atmosphere was charged with so much marsh gas that difficulty was experienced in reaching the face. The air-course to the third right butt was partly closed by the explosion knocking out timber and allowing the roof to fall. At this point along the eighth left main back to second left butt, 14 cars were badly wrecked and thrown across the entry. The flame originating in the third butt right traveled 1,200 feet from point of ignition. In the ninth left entry there were some falls, the cars were wrecked, tracks torn up, and stoppings blown out. In the ninth left and back entry explosive gas was generating. Open lights were exclusively used in these mines. The stoppings used for guiding and directing the ventilation were built of bony coal and refuse from the mine, with the exception of the shaft bottom, where they were built of masonry."

The conclusions of the inspectors were as follows:

"1. That explosive gas having accumulated in dangerous quantities in the third right and parallel entries, we are of opinion that a door on the eighth left used in conducting or directing ventilation into said third right was left open.

"2. That the gas was ignited by the flame of an open lamp or the flame of a blast fired in the coal at the face of the parallel entry to said third right.

"Owing to the fact that there was considerable explosive gas generating in the advance workings on the eighth and ninth left entries, rendering the mine unsafe, we recommend, in order to prevent the recurrence of another such accident, the following precautions:

"1. That all stoppings between inlet and return airways be constructed of concrete, brick, or stone.

"2. That permissible explosive that has passed the test of the Government Testing Station be exclusively used hereafter for blasting.

"3. That all shot holes be tamped with incombustible material and all shots fired by electric batteries in the hands of competent shot firers.

"4. That electric wires, where installed, be kept on intake airways where locked safety lamps are used.

"5. That all the workings at face of south main headings and all workings to left of south mains be worked exclusively with locked safety lamps."

Coal Dust and Zone Systems

Discussion on E. O. Simcock's Paper Printed in August Issue
Mines and Minerals

The following is an abstract of the discussion of the paper by E. O. Simcock*, which appeared in the August number of MINES AND MINERALS, and which was printed complete in the Transaction of the Institution of Mining Engineers, Vol. XL, Part 1, page 37.

In the discussion A. M. Henshaw understood that Mr. Simcock had taken the opinions and evidence on record of a number of people, and had attempted to show that the conclusions they drew, and even the facts upon which they based their conclusions and arguments, were, if not absolutely wrong, open to grave question. In the paper and illustrations which they had before them, Mr. Simcock had embodied a good many

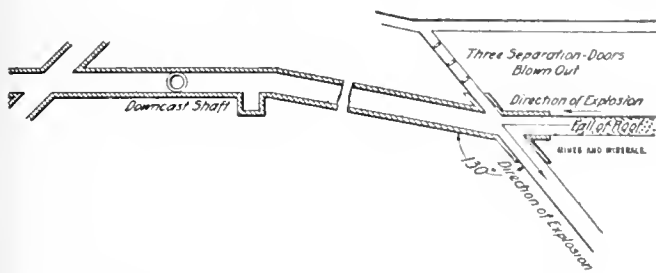

FIG. 1. PART OF WORKINGS AT BLACKWELL COLLIERY

facts that Mr. Henshaw thought had been sufficiently proved, and figures that, so far, had never been disputed

Fig. 2 related to the Talk-o'-th'-Hill explosion, and Fig. 1 was taken from Isaac Hodges' evidence. Mr. Simcock went so far as to contend that no matter whether the zone were dustless, wet, or a zone containing inert and incombustible material, it was incapable of stopping an explosion. All three contentions had been already proved, not only by the advancement of theories based upon experience, but by actual explosions underground. In the case of the Talk-o'-th'-Hill explosion, there was sufficient evidence to show that inert material actually did stop an explosion, and if Mr. Simcock would go further in his investigation he would find other cases where stone dust or inert material did actually stop the explosion, and where wet roads had also stopped it. That was also proved at Courrieres, and the figures that were given of the analyses of dust in the paper on the Courrieres explosion†, by Mr. Atkinson and himself, were not disapproved nor their value discounted, by anything that Mr. Simcock had told them. Dealing with Fig. 1, that was Mr. Hodges' explanation of the arresting of an explosion at the Blackwell Colliery. Mr. Simcock, however, advanced the theory that when the explosion, coming out of the level road to the right, reached the corner by the three cross-roads, it met with an obstruction because the road was not straight, and that that obstruction caused a rebound, the rebound preventing the explosion from advancing in the direction of the shaft. If that part of his argument were of any value, how was it that an explosion traveled through a pit at all? Why did it not rebound and stop the advancing wave, or the pioneering wave, at almost every considerable bend in the road? He, however, did not entirely base his argument upon that, but also on the reduction of pressure of the pioneering wave, when it met with the cross-roads and had to be diverted in different directions. At that point it was diverted in three directions. Mr. Hodges said that the roadway from that point to the pit bottom was free from dust, and that was sufficient reason why the explosion did not

advance to the shaft. His recollection, was that Mr. Hodges stated that the roadway to the right, in which there were three doors, was comparatively free from combustible dust. He believed that it was the airway, and, in the ordinary course, there would be very little coal dust in it. That the absence of dust stopped the explosion was sufficient for Mr. Hodges to base his argument upon. Where the explosion continued, namely, down the slant to the left, there was sufficient dust to carry it, and that was why the explosion followed that direction. If there was anything in Mr. Simcock's argument of the reduction of pressure when the explosion was diverted in different directions, then he asked: Why did it go in any direction at all? Why did it follow the downward road? It could only have followed that because there was something to propagate it, and that was the dust in that road.

Mr. Simcock went on to say that the explosive wave met with the obstruction of the doors, and that the rebound helped to stop the explosion. Mr. Henshaw believed that if there was an explosive wave going along a road, there was no ordinary door that would stop it. It would go through many miles of roadway and hundreds of doors, and in many places it seemed as though the more obstruction it received, the greater was the pressure and the more violent the explosion.

Mr. Simcock's argument was that the explosion met with some obstruction, Fig. 2, which acted as a back lash, and prevented the explosion from going in that direction, although there was sufficient dust to take it there. He was sorry that he could not agree with that explanation, and he would go further and say that he believed that if an explosion was advancing along a sufficiently dusty roadway and creating compression therein, the compression of air was more likely to assist in carrying on the explosion than if there was no compression, which was quite contrary to the opinion that Mr. Simcock expressed.

Referring to the roads, which were mainly "strait" roads, Mr. Simcock had said that as the explosion advanced toward the extreme ends of the workings, the compression there and the consequent rebound would prevent the explosion from going to the face. Mr. Henshaw contended again that compression was more likely to cause the flame to advance to the face than

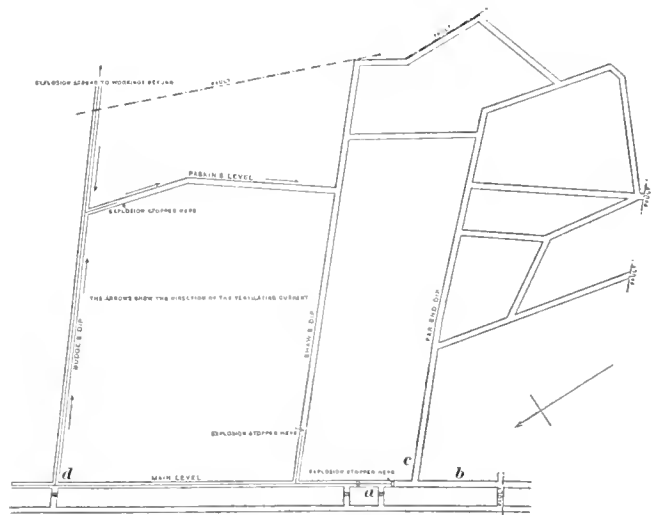

FIG. 2. PART OF WORKINGS OF TALK-O'-TH'-HILL COLLIERY

if there were no compression at all—that was, assuming that there was anything to carry the flame to the face. Mr. Simcock had raised the question of the volatile matter in coal dust being the necessary ingredient for propagating the flame. He did not think that Mr. Simcock would find anything that he had said or written which supported that statement. His view on the point was this: it was not the volatile matter in dust alone, or the carbon alone, that propagated flame, but the two together.

*Through a typographical error Mr. Simcock's name was spelled Simcock in the August number.
†"The Courrieres Explosion," by W. N. Atkinson and A. M. Henshaw Trans Inst. M. E., 1906, Vol. XXXII, page 439.

They must be under coal dust in two parts, the combustible and non-combustible, the combustible being the carbon plus the volatile matter, and the non-combustible being the ashy ingredients. He contended that any dust, anywhere, in any pit, which contained 50 per cent. of ash, was incombustible matter and would not carry forward the flame of an explosion. Mr. Simcock mentioned Captain Desborough's experiments, showing that dusts containing 80 per cent. of inert material were capable of supporting propagation. He did not know anything about those figures; he had never come across them.

Mr. Simcock asked Mr. Henshaw to refer to his own figures—Nos. 3 and 4 of the coal-dust analyses quoted in the Appendix to his (Mr. Simcock's) paper.* No. 3 contained 54.95 and No. 4, 61.15 per cent ash.

Mr. Henshaw said that those were not analyses of coal dust, but analyses of the coke resulting from the burning of the dust. Some of the analyses were of dust; others were of coke. When, after an explosion, they took a sample of the coke, that is, burnt dust, they would find little or no volatile matter. They would find some remains of carbon which was unburnt, but the bulk would be ash, because it was cinder.

Mr. Simcock said that he could not see the difference; he could not understand why they were going to have combustion in one case and not in another.

Mr. Henshaw said that if it had been possible to take some of the dust before the flame passed over it, they would not have found 61 per cent. of ash in it. The 61 per cent. of ash was there after the flame had burnt it.

Mr. Simcock said that he quite saw Mr. Henshaw's point, but Mr. Henshaw did not see his. What he wanted to say was this: in one case Mr. Henshaw said that dust would not burn if it contained only 44 per cent. of ash. Then why should this not cease at 44 per cent.? Why should it go on burning until there was 60 per cent. of ash?

Mr. Henshaw, in reply, said let them take, first of all, a sample of dust which contained by analysis, say, 44 per cent. of ash and 20 per cent. of volatile matter, the remainder being carbon. That might represent the condition of the dust before the explosion. Now, if that dust were passed through a flame, what resulted was this: most of the carbon was burnt, almost all the volatile matter was burnt, and a larger proportion of ash was left. That accounted for the 61 per cent. of ash to which Mr. Simcock was referring.

Mr. Simcock said that he quite followed Mr. Henshaw's argument, but in one case he had said that the dust would not burn with 44 per cent. of ash, and in another case that combustion would go on until there was over 60 per cent. of ash. If the presence of 44 or 50 per cent. of ash would stay combustion, then it would be impossible for combustion to proceed until the ash contents were increased to over 60 per cent.

Mr. Henshaw said that they might take as an illustration the fire in the meeting room. If they had analyzed the coal of which the fire was made that morning, they would have found that it contained about 65 per cent. of carbon and 5 per cent. of ash, the remainder being volatile matter. If they were to take the cinders, the remains of that coal at that moment, and analyze them, they would find little volatile matter, very little carbon, and 70 or 80 per cent. of ash.

Mr. Henshaw said that the zones were in the intakes only, and not in any of the returns, because they could scarcely find a record of an explosion that followed the returns to any extent. The faces generally did not contain enough fine dust to propagate a flame, and the return airways in a mine very rarely had combustible dust in them. Therefore, they only found the flame passing along the main intake roads, along which the coal was carried and pounded into dust by the men and horses traveling along them. If the zones, wet, dustless, or containing inert material, were properly set out so as to divide the workings of the colliery into small districts, so placed as to isolate one

part from another, it would be sufficient for them to be in the main intake and haulage roads.

The clearest evidence as to the stoppage of an explosion by a wet road was seen at Courrieres. The end of one of the south branch roads for 200 feet was so wet that it had been necessary to bore a hole in the floor, so as to let the water off into some old workings. The explosion traveled throughout several pits, passing along nearly 30 miles of underground roadway, but at that particular place it was stopped dead. There was no evidence of explosion, of force, of damage, or of flame beyond that wet place, and 21 days after the explosion 13 men walked out from beyond the place in question. They were the only people saved in that part of the mine, and they owed their lives to the existence of the wet zone. Mr. Simcock said in reply to a question: "There was first, a pioneering air-current, which must be able to raise the dust. He did not know of any reason why this current should not be governed by the usual physical laws relating to air-currents in mines, and, therefore, he considered that this current would be amenable to them. The source of power causing the current was the combustion reaction. In the case under review there were two currents meeting, and, after the combustion reaction, they divided at the junction of the main level and Bodge's Dip, Fig. 2, two sources of power tending to meet at the junction formed by the Shaw's Dip and Paskin's Level. The only vent for these two currents was through the upper end of Shaw's Dip. For these combined currents to pass out through this part of the road quickly enough to relieve congestion, the velocity would have to be doubled, and to double the velocity, the power would have to be increased eight times. But, as the source of power was the combustion reaction, it would be inherently impossible to increase it. The propagating action being unable to create power to relieve itself, there was compression there, which, owing to the resilience of the air, reasserted itself against the propagating action, and tended to stop it. The initiation of the explosion was remote from that section of the mine, and the rise in pressure would, comparatively speaking, be gradual, and have little or no effect in raising dust in the two roads. Therefore, the essential factor of the propagation of dust in suspension in the air would be missing, and hence the inability for the propagation of combustion through this mass of compressed air. It was necessary to discriminate between compression with dust in suspension and dust not in suspension."

Mr. Henshaw said that some further facts had been brought to mind: Bodge's Dip was a very dusty drawing road in the Seven-foot Banbury Seam. It was an old and big dip, and had a gradient of 45 degrees. It was, therefore, a very important haulage road. Shaw's Dip was a road with a much lower gradient, in which there were three or four jigs. There were a dozen faults in the dip itself, and there were probably as many men beating up the floor night after night as were employed at the face. Paskin's Level had not been used for a year or two, except as an old airway. It served simply as a means of communication between one road and another, and was only a crawl road. Paskin's Level was a dirt road; Shaw's Dip was a dirt road, because of the beating up; and then there was the dust in the main level and Bodge's Dip. That was why the explosion went up those roads, and failed to go up Shaw's Dip and along Paskin's Level.

Mr. Simcock said he would like to hear an expression of opinion as to the minimum amount of carbon and volatile matter which must be present in coal dust to prevent an explosion. How much or how little carbon must the dust contain before there was an explosion?

Mr. Henshaw said that the main thing was: How much ash or inert material was required to prevent an explosion?

Mr. Simcock said that, with regards to the zone system mentioned, there was a space of 400 yards between the zones, and he could see no reason why the explosion should not gather sufficient dust in the intervals between the zones to pass through

*Trans. Inst. M. E., 1910, Vol. XL, page 49.

them Mr. Henshaw's contention that if combustion reaction met with dust containing 44 per cent combustion proceeded no further, was quite incompatible with his remark that the cinder in the grate would on analysis show 70 or 80 per cent of ash; and this latter remark certainly supported the opinion that the application of inert dust would not be efficacious in staying combustion reaction.

J. R. L. Allott agreed with Mr. Henshaw's theory that the force of the explosion would pass up Bodge's Dip, being a large and dusty one, and would be unable to pass up Paskin's Level and Shaw's Dip owing to their contracted size and the absence of dust.

The lines on which Mr. Simcock was carrying out his research made it imperative that he should accept the facts recorded by observers, but there was a great difference between matters of fact and matters of opinion. For instance, W. W. Hood had made an explicit statement, based upon direct observation of plain facts, that: "The explosion at Clydach Vale Colliery went through 700 yards of wet roadway. This roadway, which was artificially watered, was found to be wet 10 days after the explosion."*

Had Mr. Henshaw said that the propagation of combustion went no farther along the south branch at Courrieres than to the commencement of the wet length, it would have been a plain statement of fact which, coming from a man of Mr. Henshaw's experience, could not have been called in question. But when Mr. Henshaw claimed that the propagation was stopped by the wet length, that was an expression of opinion which, in the face of Mr. Hood's clear statement of facts, required much more material evidence in its support before it could be considered incontrovertible.

It was the fear of unconscious bias that caused Mr. Simcock to take up the research on lines of pure deduction, based upon the recorded facts of other observers, and, from the results attained, he was satisfied that that course was the right one to pursue.

Certainly, such a method of research would not cause him to say that he did not believe in the recorded results of an unbiased experimenter, and he believed that he was able to discriminate between fact and opinion. Even if it could be proved that the wet length of 70 yards in the south branch at Courrieres, or in the Old South return at Talk-o'-th'-Hill did stop the propagating action in those particular cases, so long as Mr. Hood's record of 700 yards of wet roadway having failed to stay propagation stood, no security could be assured by the existence of wet zones.

Mr. Henshaw had variously stated that, in his opinion, 39, 45, and 50 per cent. of inert material would stay combustion. These seemed to be mere expressions of opinion on the ascending scale. However, as concrete quantities had been mentioned, it ought not to be impossible to calculate fairly concrete results from them. Taking a cubic foot as a unit of volume upon which to base such results, in conjunction with the higher percentage of inert material given, then, a cubic foot of air weighed approximately 560 grains, and, without reference to the minute quantities of argon, watery vapor, etc., would be made up of 432 grains of nitrogen and 128 grains of oxygen. As the density of air in reference to the solids which entered into the action was, at least, as 1 is to 1,000, and the quantity of solids introduced was only about 500 grains, the loss in weight due to mechanical displacement of air by them was negligible.

The density of carbon as a gas was 12, and oxygen, 16; therefore the 128 grains of oxygen would require 96 grains of carbon for its reduction to carbon monoxide, and in this reaction would give an excess of about 32 British thermal units of heat. If the dust of the Banbury coal were taken, 117 grains would be required to give this amount of carbon, without reference to the carbon contained in the volatile constituents. Taking the round number of 150 grains, the cubic foot of mixture would contain the following:

	Grains
Nitrogen	432 00
Oxygen	128 00
Carbon	97 95
Volatiles (as methane)	49 80
Ash	2 25
Inert material	150 00
Total weight	860 00

The specific heat of this mixture would be about .25, taking water as 1. The theoretical surplus quantity of heat which a cubic foot of this mixture would give by chemical reaction to carbon monoxide was about 32 units; therefore, its temperature under equal pressure would be 1,042° F. (561° C.). This temperature was below that of the ignition of the volatiles taken as methane, so that the volatiles—at least, at this stage—did not enter into the reaction. Proof, therefore, must be forthcoming that the other combustible material would ignite below that temperature. Sir Henry Hall had recorded the ability to ignite coal at a temperature of 752° F. (400° C.)*, and Dr. P. P. Bedson was able to ignite coal dust with a current of heated air at a temperature of only 291° F.† These were experimental facts, and as the temperatures mentioned were considerably below the temperature of the ignition of the volatiles, it was reasonable to infer that it must be the other combustible constituent of the coal dust that entered into the reaction of combustion. The writer could adduce further proof of this, but he felt that the foregoing was sufficient evidence for the present.

If a smaller quantity, down to 50 per cent. of the carbon mentioned, entered into combination with the oxygen given, there would be a considerably larger quantity of heat liberated, and, consequently the temperature would be higher. So that, by further increasing the inert material to 75 per cent., there seemed to be a better chance of more complete combustion. Fine division and complete mixing with the air would still further ensure this. The temperature also might be raised to above the ignition point of methane; hence, there was still a reserve of material to combine with any stray oxygen or to allow for further adulteration with inert material. The inert material would take up, but not retain, the excess heat, and as it would deliver it up quite as freely as it had taken it in, the presence of such material merely served as a regenerator receptacle. It might be remarked, as would be observed in the foregoing calculation, that the oxygen was the only combustible quantity which could be relied upon as being fairly constant.

From the foregoing remarks it might be gathered how little reliance could be placed upon the inert-material treatment, either complete or in zones. But to discuss the possibilities of this proposed treatment was, in the writer's opinion, as useless as beating the air, for as there was comparable authoritative evidence upon record of the insidious indirect results of inert-material dusts, even if it were incontrovertibly proved that the application of such would prevent colliery explosions, the disastrous and fatal results following their use would be out of all reasonable proportion to the disease which they proposed to cure; and it was doubtful whether any one fully comprehending those results would have the temerity to recommend their use.

來 來

The theoretical water gauge of a fan is computed from the following formula:

$$\frac{V^2 \times .078}{32.2 \times 5.2}$$

Where V = peripheral speed of fan in feet per second;

32.2 = g acceleration due to gravity;

.078 = weight of cubic foot of air;

5.2 = pressure per square foot for 1-inch water gauge.

If a fan is running at 80½ feet peripheral speed per second we have

$$\frac{(80\frac{1}{2})^2 \times .078}{32.2 \times 5.2} = 3 \text{ inches theoretical gauge.}$$

* Report of the Royal Commission on Mines 1908 [Cd. 3,874], Vol. II, page 100.

* Trans. Inst. M. E., 1908, Vol. XXXVI, page 5.
 † Ibid., 1897, Vol. XIV, page 570.

Coal Production in Japan

Locations of the Different Coal Fields, their Extent, Output, and Development

By T. Haga*

It is not long since Japan awakened from her centuries of slumber. In fact, since the usage of coal became feasible, scarcely 30 years have elapsed. Although the output in 1880 was 880,000 tons only, in 1890 it was 2,620,000 tons; in 1900, it had increased to 7,470,000 tons; and in 1910 it reached the enormous quantity of 15,540,000 tons, and 55,500,000 yen in value (Manchurian output excepted). Coal occupies the foremost position of all minerals in Japan, representing 54 per cent. of the total mineral production. Also in exportation it leads the others, standing at 2,820,000 tons, having a value of 16,300,000 yen (\$8,117,400).

The different coal fields are as follows: (1) Kyushu coal fields; (2) Hokkaido coal fields; (3) Northeastern coal fields; (4) Formosan coal fields; (5) Korean coal fields; (6) Saghalien coal fields; (7) Manchurian coal fields.

What is called Kyushu coal fields, in the southern part of Japan, produces 80 per cent. of the total coal output, or 12,420,000 tons. There are in all 1,495 properties, covering an area of 270,000,000 tsubo †. The principal operation is the Miike mine, situated on the frontier between Chikugo and Higo provinces, Fukuoka Prefecture, facing the Omuda port. This is owned by Mitsui magnate. The coal in this property is extensive and of good quality. Though there are a number of coal beds, only two are at present operated, one of which averages 8 feet thick, but measures in some places 200 feet thick; the other is from 6 feet to 10 feet beneath the former and is about 6 feet thick. According to last year's statistics, this mine produced 1,768,000 tons. The coaling ports in Japan are all imperfect, and accordingly require an enormous expense for coaling. The Mitsui magnate started the construction work for improving the Omuda port November, 1902. This cost 4,000,000 yen, and was completed in 6 years. It is now called Miike port, and is able to moor three vessels of 8,000 tons capacity. Coal is now loaded into vessels at the rate of 20,000 tons in 24 hours by the means of two machines, making a saving of 800,000 yen per annum. Besides this mine, those which produce over 100,000 tons number 28 in these districts. The greatest number of mines are in Fukuoka Prefecture and these produce over 90 per cent. of the total production in Kyushu, or 10,380,000 tons per annum. One property south of Wakamatsu port produces 70 per cent. of the total per annum in these districts, or 7,300,000 tons. This is 8 to 13 miles long by 4 to 9 miles broad, and is known widely as the Chikubu mine. It produces 50 per cent. of the total output in Japan. All the coal is hauled to Moji and Wakamatsu ports, thence is distributed to various ports.

The Kyushu coal fields are at present the most prosperous, furnishing the greater part of the export coal; nevertheless, as this prosperity has reached a climax, there is every indication that these mines are disposed to be declining. After a decade, the leading mines of the Kyushu coal fields will reduce their production. An engineer declares that, according to his estimates, the total coal hereafter to be excavated in the Kyushu coal fields is 500,000,000 tons. At present, every capitalist is planning the establishment of coal operations for the purpose of increasing the coal production.

Next to the Kyushu coal fields, come the Hokkaido coal fields. The leading mines in quantity and quality are in the Yubari, Sorachi, and Horonai districts, east of Sapporo. These cover an area of about 21 miles north to south, by about 5 miles

west to east, and have facilities for transportation. The coal in the Yubari mine is estimated to be 300,000,000 tons. The beds are said to be 1,000 feet deep by 4 feet thick. In addition, the other beds that may be operated bring up the total to over 500,000,000 tons. The mines at present in operation have coal beds from 3 to 5 feet thick; in some cases over 25 feet thick. The coal mining in Hokkaido has developed in the past few years. The production of last year was 10 per cent. of the total output in Japan, but the field shows evidences of increasing year by year. Most of the mines are owned by the Hokkaido Colliery and Steamship Co., of which the most remarkable one is the Yubari mine, which produces 480,000 tons per annum. Those mines which produce over 100,000 tons in Hokkaido number at present six, because it is only a few years since coal mining commenced in this part of Japan, but every mine promises to make a remarkable development in the near future. The claims in these districts number 140 and have an area of 80,000,000 tsubo.

Northeastern coal fields contain those in Fukushima and Ibaraki prefectures, in the northeastern part of the Japan mainland. These are ranged on the Pacific coast for a length of 21 miles. They are popularly called Joban coal fields. The annual output in these districts is 1,530,000 tons. Every prefecture in the northeastern part of the mainland abounds in gold mines, but coal is worthy of note in the two prefectures mentioned. The quality of coal stands third and the quantity cannot be said to be abundant. For all that, as these districts are near Tokyo, the consumption is comparatively large.

Formosan coal fields are not worthy of note. These mines have an area of 10,000,000 tsubo, producing roughly 140,000 tons per annum. They are mostly situated in the part of Kylung.

Korean coal fields abound in places in the peninsula. Among the best is the mine 6 miles in length along the Daidoko from Heijo. It is known as Heijo coal, and is used for the Imperial navy.

The Saghalien coal fields are also promising. The area of coal at present known is estimated at 235,670,000 tsubo. The area will, no doubt, be increased by an elaborate investigation going on. The various beds range from 3 feet to over 10 feet in thickness. On the whole, as it is not long since this land was taken by Japan, so it lacks facilities of communication and traffic, by reason of which there are very few who invest in Korea, but the government plans to work the profitable minerals as government enterprises, capitalizing at an enormous sum. The government is encouraging capitalists and engineers to explore these districts for coal.

In the Manchurian coal fields, the mine which is especially noteworthy is the Fushan, under the control of the South Manchurian Railway Co.

Fushan is situated 10 miles east of Mukden. The claim is 1 ri* north-south by 5 ri west-east along the canal traversing this district east-west. This district is reached by a branch line of the South Manchurian Railway, which branches off at the Sokaton station and terminates at the opposite side of a canal beyond Fushan Castle, through Senkiusai, Yohakuho, and Rokatai.

The Fushan mine is divided into two parts, eastern and western. In the western part there is the Rokatai mine, also the Raisen mine near Senkiusai, and Togo mine near Yohakuho, where shafts are in course of construction and will be completed next year.

The coal is of the bituminous variety and has a glassy black color. The coal beds extend 4 miles and in thickness they are rarely exceeded. They measure 174 feet thick in Senkiusai, 120 feet thick in Yohakuho, and 144 feet thick in Rokatai mines. This great field was operated by Chinese hundreds of years ago, when these settled in the capital at Mukden, but on account of the customary superstition, the exploration was strictly pro-

*39 Sakanamachi, Ushigome Tokyo.

†Yen = \$.498. Value per ton \$1.78.

‡Tsubo = 6 square feet, according to Standard Dictionary.

* Ri = 2.43 miles.

Como Mine No. 5

The Method of Working the First Mine in the United States to Adopt Shot Firers and Sprinkling of Dust

By Joseph Watson*

Como mine, No. 5, which was worked out and abandoned October 1, 1896, was situated near the town of that name on the interior plateau of the Rocky Mountains, in Park County, Colo. Opened at an elevation of 9,500 feet above sea level, making it at that time one of the highest coal mines in the world, its location gave it a distinct market advantage over mines at a lower altitude in saving a vertical haul of nearly 4,000 feet. For this reason, as well as because of the excellent steaming qualities of the coal, practically the entire output was used by the South Park Division of the Colorado & Southern Railroad, with headquarters at Como.

The coal seams in and around Como are "pockety" in character, the one on which No. 5 was opened having an extent

hibited. In 1901, Mr. Oshogo and other Chinese applied for permission to operate the Fushan mine. This was granted, because Mr. Soki, then Viceroy, memorialized their application to the Throne, explaining the absurdity of the hitherto observed superstition. Mr. Oshogo got possession of Senkiusai mine and Mr. Ozu and Mr. Choshisu got the Yohakuho and Rokotai mines. Mr. Oshogo cooperated in this enterprise with Messrs. Ei, Shiyoku, and others, and operations were making progress by degrees, but at that juncture there took place a difference between him and the other three, who brought action before the Mukden Viceroy, but this case did not attract the viceroy's attention. Therefore, he exerted himself to monopolize this mine and by the support of the Russians in Mukden won the case. As some of the expenses of this proceeding were assumed by the Russians, he was obliged to accede one-half of the rights of the mine. On the other hand, Messrs. Ozu and Choshisu also acceded part of their rights to interpreter Mr. Kihotai, who afterwards acceded his rights to the Russians. Thus, at last, half of the western mines and part of the eastern were owned by Russians. In 1902 the Russians planned to develop the coal, and excavated various pits and had the construction work under way, including a branch line of railway, east of Sokaton, when the Russo-Japanese war broke out. Japan occupied Fushan Castle and the whole of the above coal mines March 9, 1905. In April, 1907, the South Manchurian Railway Co. was organized, and at the same time these mines came under the control of the company. As soon as Doctor Matsuda was engaged as superintending engineer he made radical reforms. Moreover, Taisan and Togo mines have been exploited, land purchased for a new town, and many houses built, with waterworks, hospitals, and schools, etc. In 3 years all these improvements have made great progress.

According to the table of output, at the end of last year Senkiusai, Yohakuho, Rokotai, Taisan, and Togo mines produced 722 tons, 949 tons, 32 tons, 62 tons, and 342 tons, respectively, per diem, totalling 3,113 tons in all; of which 139 tons per diem was consumed for the productive use. The remainder, 2,860 tons, was exported. When Taisan and Togo mines are completed, they will produce 4,000 tons. Therefore, in 2 years or so the Fushan mines will produce 7,000 tons per diem.

The principal coal mines and their output are as follows:

Name of Mine	Place	Owner	Output Tons per Annum
Miike mine.....	Fukuoka Prefecture	Mitsui & Co.	1,768,268
Mitsui Hondo ...	Fukuoka Prefecture	Mitsui & Co.	661,333
Onoura.....	Fukuoka Prefecture	Kajima	586,289
Yubari First Mine	Hokkaido	Hokkaido Colliery & Steamship Co.	471,372
Meiji.....	Fukuoka Prefecture	Yasukawa	433,401
Shinnyu.....	Fukuoka Prefecture	Mitsu Bishi Co.	424,743
Shiokashira.....	Fukuoka Prefecture	Furukawa Mining Co.	391,358
Futase.....	Fukuoka Prefecture	Government	372,963
Otsuji.....	Fukuoka Prefecture	Kajima	353,612
Namazuda.....	Fukuoka Prefecture	Mitsu Bishi Co.	335,370
Tadakuma.....	Fukuoka Prefecture	Sumitomo	324,504
Mitsui Hondo.....	Fukuoka Prefecture	Mitsui & Co.	316,590
Mitsui Yamani.....	Fukuoka Prefecture	Mitsui & Co.	297,038
Oto.....	Fukuoka Prefecture	Buzen Colliery Co.	297,020
Kaneta.....	Fukuoka Prefecture	Mitsu Bishi	296,974
Yoshinotain.....	Fukuoka Prefecture	Mitsu Bishi	263,001
Hokoku.....	Fukuoka Prefecture	Yasukawa	261,854
Aichi.....	Fukuoka Prefecture	Mitsu Bishi	261,325
Uchigo.....	Fukushima Prefecture	Iwaki Colliery Co.	258,921
Iriyama.....	Fukushima Prefecture	Iriyama Colliery Co.	251,736

來 來

The oil fields of Lambton County, Ontario, have been in operation a long time, and are unique because of the small individual production of the wells, which is only a few gallons a day, and of the economy with which they are operated. Being shallow, many wells may be worked by one engine on the "jerker" system, and so give a profit which, if not large, is constant.

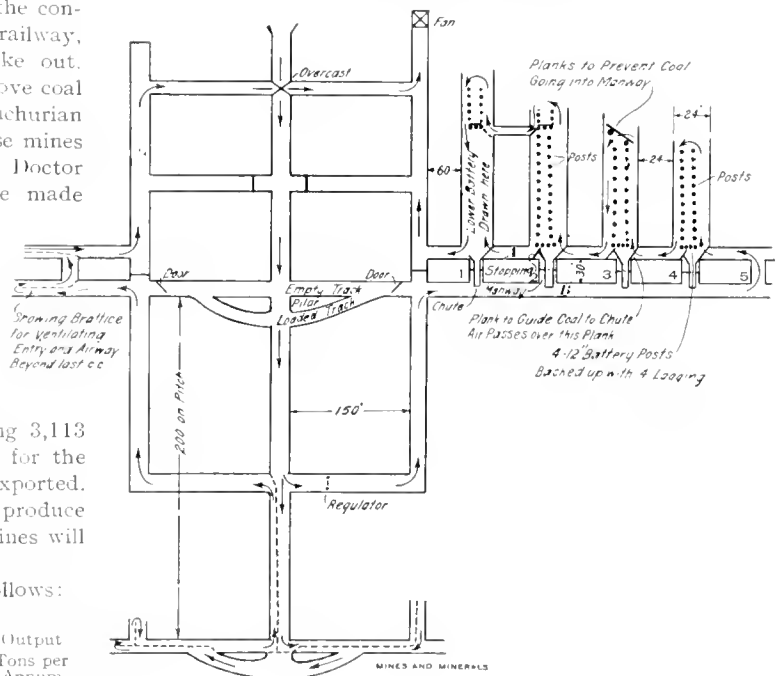

FIG. 1. PLAN OF COMO MINE

of about 1,800 ft. x 3,600 ft. with an average dip to the east of 45° 36'. While the coal averaged 6 feet 6 inches in thickness, it was decidedly irregular, frequently being as thin as 4 feet and rarely expanding to 14 feet.

As the seam made a large amount of gas, and as the coal produced large amounts of highly explosive dust through the attrition of its particles in dropping through the chutes from the face of the room to the entry, or loading level, more than ordinary precautions were necessary to prevent a repetition of the dust explosion of the fall of 1892 in which 26 men lost their lives.

Fig. 1 shows the method of laying out and ventilating the mine. It may be said to consist in general of a three-entry slope driven directly to the dip, from which a single-room entry or level was turned and from which latter the rooms were driven up the pitch. In sinking, the middle of the three slope entries was first advanced 100 feet. At this point cross-cuts were turned both left and right. At 150 feet from the central slope, airways were turned up hill to the fan, the slope being continued downward to the next cross-cut from which, as before, the two airways were driven on the rise to intersect those first

* General Superintendent National Fuel Co., Louisville, Colo.

driven from the upper cross-cut. Each half of the mine was ventilated independently by its own split and the air-current was controlled by brattices to the face of each heading and of each of the three slopes.

On the levels, or cross-entries, owing to the pitch of the coal, there was a triangular-shaped space over the cap timbers in which large amounts of gas accumulated. In order to discharge this, air with a compressor pressure of 80 pounds to the square inch was conveyed to the face in pipes, and a portion of it discharged into this space by means of the connection shown in Fig. 2. It will be noted that another portion of the air was thrown against the face of the entry.

At the slope the loaded track was driven in the rock hanging wall, the empty track only being in coal. Connection to the slope tracks was had by means of a hinged door on which the switches were laid, its upper end resting on the slope rails. The air passed around this door and down the slope through holes

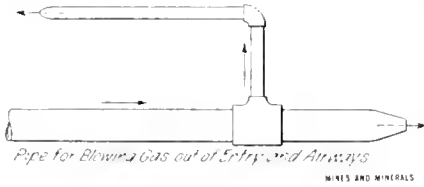

FIG. 2

on either side. When hauling from a lower level the upper end of the door was raised by means of a rope passing to a windlass, thus allowing the cars to pass under it.

Rooms were 24 feet wide with a pillar of the same size, and were driven from the haulage entry A, with a neck width of 9 feet. After being driven narrow for 30 feet the rooms were connected by cross-cuts which served for a back entry or air-course. The rooms were given the full width on the upper side of this first cross-cut.

Two rows of posts 4 feet apart in the direction of the dip and 10 to 12 feet apart on the strike were led up the room. The inside of these posts was planked with 2-inch slabs, forming a storage chute for the coal. The bottom of the chute or battery was made of four 12-inch posts lagged with 4-inch poles. The sides of the chute were continued to the roof in order to force the air up to the face. On the left side of the chute was a 4-foot wide manway, and on the right side an air-course 8 to 10 feet wide. The chute in the neck of the room, or loading chute, was about 4 feet wide with sides 2 feet high and an end gate which could be raised to let the coal into the mine cars on the entry. At the entry the manway was bratticed shut and provided with a door, and a curtain was hung over the chute to prevent leakage of air. After a room was holed through to the next place on the left, the lower chute was taken up and a new battery built just above the cross-cut. The details of the room work are shown in the illustration.

The coal was undercut as far as possible, say to a depth of 2 feet, and was broken down by shot firers after all but the night-entry shift had left the mine.

Considerable water had to be pumped from the bottom of the main slope against a head of 900 feet. In May, 1895, 1½-inch water lines were laid from the discharge pipe of the pump through the various levels and were provided with hose connections at the mouth of each room, and with an ample quantity and pressure of water, every place in the mine was thoroughly washed down every other day.

來 來

According to the United States Consular Report, the mining industry of Spain is undergoing a great change. The miners have become united by large unions, whose influence upon wages and hours of work has been marked. This increased cost of production has caused the installation of modern labor-saving machinery and means of transporting the ore. The daily wages in the different mines range from 32 to 86 cents, and the working hours from 7 to 12. England and Germany are the principal purchasers of Spain's mineral products, though large shipments of iron ore are sent to the United States.

來

Correspondence

來

Rolling Friction

Editor Mines and Minerals:

SIR:—In reply to inquiry of W. C. A., June number, regarding rolling friction, if there is any difference at all it would be due to oil freezing in the car boxes, and to overcome this they use an oil in winter termed zero oil, which will not freeze readily, while in summer they use a thick oil which will not melt too freely. Decrease of temperature causes an increase of journal friction, but tends to decrease rolling friction on rails, owing to a firmer unyielding roadbed. The reference in the locomotive works catalog might refer to the decrease in steaming capacity of locomotives in winter, which lessens the tractive power. In case of mine cars I would say there is little difference, because mine temperature is nearly constant summer and winter.

J. T. BEARD

Editor Mines and Minerals:

SIR:—Replying to your correspondent W. C. A. regarding the friction of mine cars, I am of the opinion that the two frictional resistances mentioned do not refer to the same thing. The first probably refers to the rolling friction, and the second to the journal friction. Undoubtedly, the journal friction would be greater in winter than in summer, as the lower temperature would tend to solidify the lubricants and also to cause some contraction of the parts, thus causing a closer running fit. On the other hand, the rolling friction would undoubtedly be slightly greater in summer than in winter.

To illustrate, assume a dray being drawn over an asphalt pavement in winter when the pavement is hard. The rolling friction under these conditions is comparatively small. During the summer when the asphalt is soft and the wheel depresses it somewhat in passing over it, the rolling friction is much greater. The same would be true in a measure of a wheel rolling upon a rail. The summer temperature might well be 100 degrees or more higher than the winter temperature, and the higher temperature would undoubtedly cause the wheel to depress the rail somewhat more than it would at the low temperature, thus increasing slightly the rolling friction. However, in the case of a wheel rolling upon a rail, working under ordinary conditions, this increase of friction would, it seems to me, be so slight as to be inappreciable; yet there is no doubt but that the rolling friction would thus be very slightly increased.

A. B. CLEMENS

Double Explosions from Powder

A correspondent writes: "There were three holes drilled 5½ feet each, in which three sticks of powder were used in each hole. These were tamped with clay and fired with a detonating cap. The three shots exploded six times with the three detonators. What caused the three extra reports?"

It is rather difficult for one to account for this phenomenon, but as a general theoretical explanation to explain the double reports it might be stated that the formula under which the powder was manufactured was not balanced properly in its supply of oxygen, and since the lack of oxygen was subsequently supplied from the air, secondary explosions resulted.

Questions of this kind have been received several times since the use of quick explosives has become common in coal mines.

Correction

In our last number, in a foot note accompanying an article on the Waterfall Chute, Mr. Paul Sterling, M.E., was mentioned as Mechanical Engineer of the Lehigh and Wilkes-Barre Coal Co., instead of Lehigh Valley Coal Co.

Electric Mine Lamps

Description of a Practical Storage Battery Lamp Especially Designed for Use of All Classes of Mine Employees

By J. T. Jennings* *

During 1908 the management of the Philadelphia & Reading Coal and Iron Co., awake to the dangers and disadvantages of the open-flame miners' lamp, and considering the benefits in safety, efficiency, and cleanliness an electric lamp would have over the ordinary open-flame oil lamp in the hands of a miner, arranged a systematic plan to investigate the possibilities of the development of a practical electric storage-battery lamp. A canvass of the United States showed that no electric miners' lamp existed at that time, and that practically no serious thought had been given the matter.

It was therefore evident to Mr. W. J. Richards, vice-president and general manager, that to secure the desired lamp it would be necessary for the electrical department of the company to devise and develop one that would meet the requirements. Naturally, the first requirement was a storage battery that would be light in weight, small in size, and reliable in action. The first experiments conducted were with various cells of the alkaline type, and lead type, with the result that the pasted cell was selected. It was soon demonstrated that a liquid cell was not practical because the electrolyte could not be prevented from spilling and destroying the miner's clothing, also that the vertical type cell could not be constructed to satisfactorily retain the active material, and prevent short circuits.

Subsequent experiments proved that the "Hirsch" type of cell met the conditions better than other types. This battery consists of two electrodes arranged on a horizontal instead of a vertical plane, the plates being separated by a combination of wood fiber and perforated hard rubber substance.

To prevent the spilling of electrolyte, tests were conducted with the view of finding some method of solidifying it. A material was found, which, when treated with acid, forms gelatinous silicic acid, which sets to a congealed jelly-like substance in about 30 minutes after charging. Some difficulty was experienced in getting the proper mixture, which would at the same time form a congealed mass without causing too much internal resistance in the cell.

The dimensions of the batteries in most of the equipments are 2 in. x 3 in. x 4.5 in., but the size of those manufactured now is 2 in. x 3 in. x 4 in. It is provided with a belt support, weighs but 2 pounds, and is capable of supplying electricity for a 3-candle-power lamp, at 2 volts, for 12 to 14 hours.

While the battery, as described above, is giving good results, the electricians and engineers of the company are now conducting experiments on various substances as an absorbent for the electrolyte, by means of which

they desire and hope to accomplish three purposes: viz.: To effectively prevent acid leakage; to positively hold all active material in place; and to reduce the internal resistance of the cell to a minimum. The results now being secured are very gratifying.

* Electrical Engineer, Philadelphia & Reading Coal and Iron Co., Pottsville, Pa.

Next to the battery, the important features of the outfit are the cord, reflector, and lamp. The outfit was in use but a short time when serious cord troubles appeared, caused by the various positions of the miner when working, and by perspiration saturating the cord and destroying its insulating properties. Specially constructed cords have practically eliminated all troubles from this source.



FIG. 2. ELECTRIC LAMP OUTFIT AS WORN

To obtain the greatest efficiency in light from the 2-volt cell, a special high-efficiency Mazda lamp is used in connection with a strong parabolic reflector producing a clear light with no shadows. The lamp is protected from injury and dirt by a heavy clear glass front. A view of the entire outfit is shown in Fig. 1.

The manner in which the miner wears the outfit is shown in Fig. 2. The battery, weighing, approximately, the same as a driver's oil can (2 pounds) is supported on the hip by the belt usually worn by the miner, though some of the men prefer the support suspended over the shoulders. The circuit from the battery to the lamp is completed by a special flexible cord worn under the clothing, thus protecting it from damage. The lamp, reflector, and cord are detachable from the cap and the battery.

In the earlier outfits the current was turned on and off by a switch on the outside of the battery, but that has been eliminated, as the mere insertion of the small pins, or plugs on the ends of the cord into the proper sockets on the battery turns on the light, and the pulling out of one breaks the circuit and extinguishes the light.

One small feature that also proved a good one was the provision of a short tape fastened to the cord directly above where it branched to run to the two poles of the battery, and made a trifle shorter than the divided cord. This tape is provided with a flat hook on its loose end which slips into a receptacle on the outside of the battery, and its function is to prevent the connections with the batteries being broken. That the lamp is a practical one is evidenced by the fact that it not only furnishes a better light than the ordinary lamp, but all things considered it is more convenient. By means of the reflector used the rays of light are thrown further, and the miners soon become accustomed to bend the head so as to throw a comparatively strong light on any point they desire. Or, as the lamp is easily detached from the cap, it can be taken in the hand and the rays can then be thrown wherever desired. When attached to the body by either a belt or by a shoulder support the battery is out of the way, does not interfere with free motion of the body in any direction, and its weight is not felt. The cord does not interfere in any way with free motion. A man wearing the outfit can put himself quickly in any position without restraint. He can use a pick, drill, or shovel, set timbers, lay rails, pick up and lay down materials, or do any work desired with as much

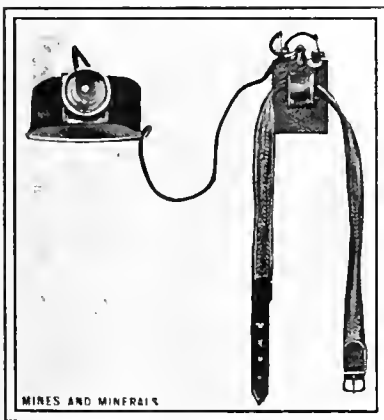

FIG. 1. LAMP OUTFIT COMPLETE

or more freedom than when wearing an ordinary miner's lamp, and in addition, he does not experience the nuisance of smoke, dropping oil, or the usual mess incident to the oil lamp. At this writing there are about 1,000 of these lamps in use at the Philadelphia & Reading Coal and Iron Co.'s collieries.

The recharging of batteries and the care and maintenance of the lamps is usually done at a station located in the safety-

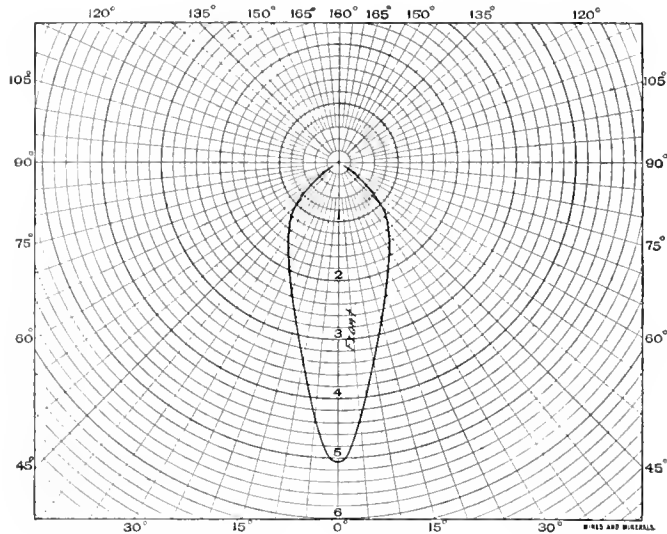

FIG. 3. LIGHT DISTRIBUTION

lamp house. The man in charge of the safety lamps also charges the batteries, except at mines where a large number of the electric lamps are in use. In the latter case a battery man is employed.

Fig. 4 shows the interior of one of the charging stations. The charging apparatus consists of a series of racks for supporting the cells arranged so that the batteries are always placed in the same position where the wire connections are easily made in such manner as to prevent any reversals. Direct current from the ordinary mine-haulage circuit is used for recharging. An ammeter indicates the proper charging current, a voltmeter the conditions of charge, and a rheostat or bank of lamps controls the charge, the rate of charge being 2 amperes for 8 hours, followed by 1 ampere for 1 hour. This permits as many as a hundred batteries in series being charged from a 250-volt circuit. A system of numbering the batteries is arranged for record purposes, each miner retaining the same battery, receiving it from, and returning it to the lamp man, who inspects, cleans, recharges it, and makes any necessary repairs.

Fig. 3 is a graphical chart showing the candlepower distribution of the lamp due to the reflector. As shown, the 2-candlepower Mazda lamp, in practice, yields as much light as a 5-candlepower lamp without a reflector.

It is not the intention of the officials of the Philadelphia & Reading Coal and Iron Co. to replace safety lamps with the new electric lamp. They realize that the safety lamp has a field of its own which cannot be encroached on, although the electric lamp has been thoroughly tried out under gaseous conditions and proved absolutely safe because of its low voltage, and also because no air can get to the incandescent filament. Most satisfactory results are being obtained with the Hirsch lamp by all classes of mine employes, and its use around stables and other buildings where inflammable materials are necessarily stored is particularly recommended. In dry portions of the mine where considerable timber is used, and for the use of repairmen employed in timbering on slopes and in main headings, it is especially valuable, as all danger of fire is eliminated. Fire bosses equipped with the electric lamp, in addition to the safety

lamp, are enabled to make more thorough and extensive inspections of working places, and to do their work in a safer and more expeditious manner.

來 來

The Two-Million-Dollar Trespass Suits

The much heralded suits involving upwards of \$2,000,000 damages brought by Mrs. Annie E. Ott *et al.* against the Berwind White Coal Mining Co. were, after numerous postponements, decided in favor of the defendant company, at the June term of the Somerset County, Pa., Court.

The large amount of damages claimed, the attack on the integrity of the established nomenclature of the coal measures, and the prominence of the witnesses summoned, made the case one of the most celebrated ever tried in the courts of Western Pennsylvania.

The contentions of the plaintiff, Mrs. Annie Ott, were (1) that the Berwind-White Coal Mining Co. was mining the C', or Upper Kittanning, seam of coal beneath her farm, which the Berwind-White Co. did not own, and therefore had no right to mine; (2) that the defendant was not mining the B, Miller, or Lower Kittanning seam, the mineral right of which was owned by the company; (3) that through reckless methods of mining, the defendant had irreparably ruined the surface of the plaintiff's farm and destroyed the springs upon the property, for all of which the plaintiff prayed that remuneration to the amount of \$1,071,914 be awarded. This amount, together with the claims of the other plaintiffs, amounted to \$2,160,000.

The principal point at issue was the identification of the coal bed being mined at the No. 30 colliery of the Berwind company. Although for nearly 9 years, more or less trouble was experienced from the owners of some of the farms, it was not until 1906 that suit was brought and then suddenly withdrawn by the plaintiff. Two years later, the suit recently decided was brought by the same party, but, in addition to the damages asked for the coal removed, a second claim for damage to the surface was included. Between the bringing of the first and second suits, a large number of diamond-drill holes had been sunk by the plaintiff and her associates to bolster up their claim that the bed being mined is the C', or Upper Kittanning, seam.

To offset or verify the records reported, the company sunk several holes in practically the same territory. In both holes sunk by the plaintiff, the horizon of the Upper Freeport seam

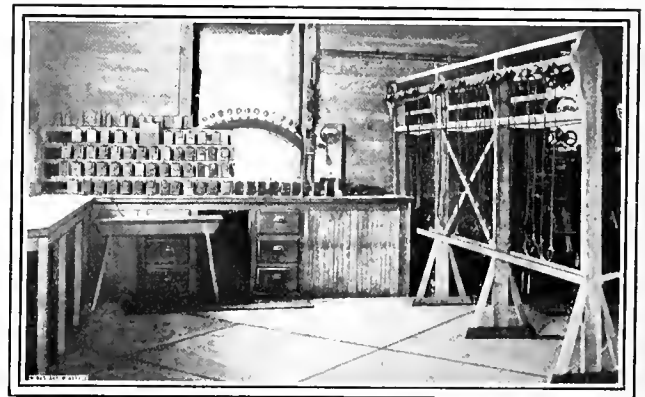

FIG. 4 CHARGING STATION

was represented by a small bed of coal in one, and slate and fire-clay in the other, and in both these holes, the Upper Freeport limestone, which occurs some 12 feet below the coal bed, was replaced by sandstone, while above it the usual slates and shales had been likewise replaced by sandstone. Notwithstanding the fact that all the other beds in the series were present at the usual intervals, the geologists of the plaintiff

were led into incorrectly correlating them by beginning to letter from the lowest bed; hence the entire set of seams received letter designations entirely different from those by which they had been known for nearly 40 years. All the regular beds of the series were represented by coal or their horizons by slate, shale, or fireclay. Since two coal beds had been introduced into the section of the Lower Productive series, in addition to the seven seams usually present in this series, it became necessary, in order to account for this newly proposed nomenclature, to designate one regular member as an "unnamed bed," and to do absolute violence to the section by placing the Upper Freeport coal in the Conemaugh series.

The three limestones of the series, the Upper Freeport, Lower Freeport, and Johnstown Cement limestone were found in many of the drill holes and in all of the open cuts on the hillsides on the farms adjoining the Ott property.

The Upper Freeport coal in the No. 7 drill hole was represented by a seam of coal 1 foot 3 inches thick enclosed between shales 4 inches and 6 inches thick, while in the No. 10 hole, a soft fireclay and fossiliferous shale 2 feet 6 inches thick indicated its horizon. In both these holes, the Upper Freeport limestone had been replaced by sandstone, the bottom stratum containing pebbles about the size of a pea or less. This replacement of the limestone and the absence of the shales and slates usually found between the bottom of the Mahoning sandstone and top of the Upper Freeport coal deceived the plaintiff's geologists and led them to believe that the highest coal cut was the Mahoning seam.

As this limestone and the coal were always found in other drill holes and shafts in the immediate vicinity, it was apparent that the conditions on the Ott farm were abnormal.

With such weak evidence as this, the plaintiff's geologists attempted to attack the well-established and long-accepted nomenclature of the Lower Productive series, but fortunately failed signally.

In the section in controversy, some of the best sections of this series have been developed, for not only are the Mahoning and Homewood sandstones forming the upper and lower lines of demarkation between the Conemaugh and Pottsville series present and visible, but all of the seven coal beds and the three limestones.

The resemblance of the C', or Upper Kittanning, and the B, Miller, or Lower Kittanning, seams in the territory, to the same beds in other localities where no question as to their identity had ever been raised was remarkably striking. It is hard therefore to see how even an ordinary geologist could be led into drawing such erroneous conclusions, and advise clients to spend thousands of dollars in bringing a suit where there was not the slightest possibility of winning before an unprejudiced jury.

The trial lasted for 6 days, but at any time after the testimony of the plaintiff's witnesses had been given, the trial judge would have been entirely justified in ordering a non-suit. The Berwind-White Co.'s attorneys would not make such a request, preferring to have the jury pass upon the case.

At the opening of court on Monday, June 5, the plaintiff, through one of her attorneys, requested Judge Kooser to instruct the jury to find for the defense and to enter non-suits in the other cases, which was done. Thus ended a case which should never have been brought, for there was nothing upon which to base it.

采 采

Society Meetings

The council of the Institution of Mining and Metallurgy has, on behalf of the institution, accepted an invitation from the Canadian Mining Institute to hold a joint meeting in Ottawa or Montreal about the first week in March, 1912. The exact date and other information in regard to the meeting will be issued

in due time, but it may now be stated that it is proposed to arrange a visit to one or two important mining camps to follow the meeting.

The executive committee of the American Mining Congress, J. F. Callbreath, secretary, has given notice of the annual meeting of the members of the American Mining Congress, which is to meet at the La Salle Hotel, Chicago, Ill., on Tuesday, September 26, 1911, at 7:30 o'clock p. m., for the purpose of electing one director to hold office for 1 year, one director to hold office for 2 years, five directors to hold office for 3 years, to succeed John Dern, B. F. Bush, S. A. Taylor, James Douglas, and Carl Scholz, whose terms of office expire, and Geo. W. E. Dorsey, deceased; and for the transaction of such other business as may be properly brought before said meeting.

采 采

The Disposal of Ashes at Mine Boiler Plants

The Philadelphia & Reading Coal and Iron Co. has adopted a method of disposing of ashes at their large boiler plants, located on hillsides, that is worthy the attention of mine managers generally, on account of its simplicity, efficiency, and economy.

In front of each line of boilers there is a trench of sufficient depth to accommodate a flume lined with semicircular steel plates 16 inches in diameter, set at a grade of about 1/2 of an inch to the foot. Where the grade is 1/2 inch to the foot satisfactory results are secured, but the slightly heavier grade is preferred. In front of each ash-pit door this trench containing the flume is provided with removable covers which can be readily taken off or put on. The construction of the flume is shown in plan and section in Fig. 1.

This steel-lined flume is extended from the boiler house to an ash dump by a similar but open flume, lined with terra



FIG. 1

cotta of the same diameter and set at the same grade. The ash dump is situated on lower ground at any desired distance from the boiler plant. In cases where the hill slope is comparatively steep the flume from the boiler house is carried through a short culvert to the face of the hill, whence it emerges and is extended to the dump.

To supply water to move the ashes, the mine drainage is delivered by the mine pumps to a reservoir or tank placed at a convenient elevation above the boiler house. From the reservoir or tank a 3- or 4-inch pipe runs to the end of the boiler house and is then given a vertical drop of 10 or 12 feet, ending with a curved end so as to deliver water into the head of the flume. A convenient valve, actuated by a lever, is attached to the vertical pipe.

When the time arrives for cleaning ashes from the ash pit, the fireman uncovers the flume immediately in front of the ash-pit door, opens the valve in the vertical pipe, and scrapes the ashes into the flume. The running water extinguishes any live coals and carries all the ashes rapidly along the flume to the place of deposit. In some instances the ashes are flumed a quarter of a mile, and in no case is there any chance for a fire in the ash bank. In the coldest winter weather the flumes have worked perfectly, as the heat from the ashes keeps the water at a temperature above the freezing point. The water after performing its function naturally drains into the nearest stream, just as it would have done if it flowed direct from the column pipe without performing any useful work.

Economical Fire-Room Methods

A Method of Firing by Which the Greatest Efficiency Is Obtained From the Fuel

In recent years economical fireroom methods are not alone practiced by manufacturing establishments, in fact, they have been extended even to coal mines, where once no attempt was made to save fuel. In an article by F. R. Low in Bulletin 187 of the Sturtevant Engineering Series were given the data from which this article was prepared. George H. Dinman, consulting engineer of the American Woolen Co., realizing that the boiler room is the place to save fuel, has installed "Hibernian" automatic stokers, fans to furnish induced draft, economizers to reduce the temperatures of the escaping gases and raise the temperature of the feedwater from 105° F. to 185° F. Some people neglect to wash their children's faces with the excuse that they will get dirty again. At the plant mentioned, however, the fireroom is kept clean by not letting it get dirty. The interior of the boiler house is clean, light, and roomy, both in front and behind the boilers, consequently it is not necessary to knock the sides out in case repairs or changes are contemplated. There are at this plant 42 horizontal return-tubular boilers, 72 inches in diameter, with 20-foot tubes, which indicates that there is some coal being used. The record shown in Fig 1 is an average indication of what is being done in the way of heat economy.

The inner diagram gives the variation in the temperature at which the gases go to the stack, and, as may be seen, this approximates 200° F. The outer diagram shows that the temperature of the gases as they leave the boilers is never above 500° F., and part of the time below 400° F. This remarkably low stack temperature is due to careful study on the part of experienced power-plant engineers, who desired to construct a plant that would generate power at the lowest possible cost by the utilization of every possible heat unit from the fuel burned under the boilers. To this end Sturtevant economizers were adopted to reduce the final temperature of the gases and while so doing raise the temperature of the feedwater from 105° F. to 185° F.

From the low stack temperature of the gases it might be assumed that an excess of air was admitted to the furnace and that this cooled them; but this is not so, for the company employs a chemist who comes each week, picks his own boilers and fires, and makes the gas analyses, records of which show

TABLE I. ANALYSES OF GASES FROM BOILERS

Boiler No. 6			
Time	Per Cent. Carbon Dioxide	Per Cent. Oxygen	Per Cent. Carbon Monoxide
8:45 A. M.	11.1	3.5	
8:55 A. M.	11.4	4.6	
Boiler No. 9			
9:05 A. M.	15.4	.9	.5
Boiler No. 33			
8:45 A. M.	13.1	4.8	
8:55 A. M.	11.8	6.6	
9:05 A. M.	11.6	7.1	
9:15 A. M.	10.8	7.7	
9:30 A. M.	8.4	11.5	
9:40 A. M.	13.7	4.8	.3
Boiler No. 35			
9:50 A. M.	13.5	6.0	

Boiler No. 15			
Time	Per Cent. Carbon Dioxide	Per Cent. Oxygen	Per Cent. Carbon Monoxide
9:20 A. M.	15.0	3.6	
9:30 A. M.	12.8	6.7	
Boiler No. 18			
9:40 A. M.	12.7	6.4	
Average	14.1	4.5	.1
Boiler No. 28			
10:05 A. M.	13.3	5.2	.1
Boiler No. 29			
10:15 A. M.	14.0	5.3	.2
Boiler No. 25			
10:25 A. M.	11.8	7.5	.1
10:35 A. M.	10.4	9.7	
Average	12.0	6.9	.1

little excess air. In the accompanying Table I the gas samples from boilers 6, 9, 15, 18, 28, 29, and 25 were obtained from the uptake just back of the front firebox doors; while samples from boilers 33 and 35 were taken from the center of the roof of the boilers. Samples from boiler No. 33 show what value the flue gas analyses may have in locating trouble with the fire; for instance, it was found after the 9:30 A. M. sample was taken that the fire-bed had a hole in one side through which excess

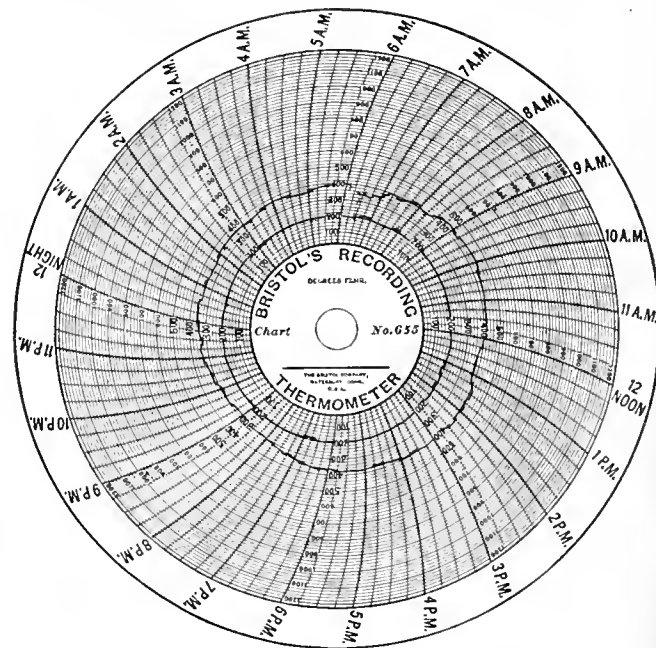

FIG. 1

air was flowing. This was remedied, and the 9:40 A. M. sample shows that the oxygen had decreased 6.7 per cent. The small percentage of excess air shown in the analyses represents a considerably less loss at the low temperature of the stack gas than would be the case at the usual temperature of most stacks, which is approximately 500° F. If it were possible to cool the gas entering the stack to the temperature of the air entering

the firebox it would be immaterial how much excess air there was, for none of it would go away hotter than it came. Table II gives the loss in dollars due to stack temperatures.

The woolen mill boilers are supplied with flat shaking grates and are fired by hand. The plant is divided into four groups of 10 boilers each, so that each group has 20 fire-doors and four

TABLE II. LOSS OF HIGH TEMPERATURE IN STACK ON EVERY \$1,000 WORTH OF COAL BURNED

Stack Temperature Degrees F.	Per Cent. of Total Heat Going Up Stack	Loss on Every \$1,000 Worth of Coal Burned
200	4.34	\$43.40
250	5.89	58.90
300	7.44	74.40
350	8.99	89.90
400	10.54	105.40
450	12.09	120.90
500	13.64	136.40
560	15.30	153.00

Temperature of outside air = 60 degrees. One pound coal = 14,500 B. t. u. Eighteen pounds of air per pound of coal.

stokers. The man at the end of the group fires the 1st, 3d, and 5th doors; the second man then fires the 7th and 9th doors; the third man the 11th, 13th, and 15th doors; and the fourth man the 17th and 19th doors. Each man puts on nine scoops of coal, and when the first man has finished coaling the 5th door, he trims the fire through doors 2 and 4, then goes and sits down in a comfortable chair provided for him. Fireman No. 2 having fired his two doors and trimmed his three fires, sits beside the first man in a second chair. After an interval of 8 or 10 minutes fireman No. 1, seeing fireman No. 4 finish his turn, gets up, coals furnaces through doors Nos. 2 and 4, trims fires through doors 1, 3, and 5, then sits down again. Fireman No. 2 commences to throw coal into No. 6 as soon as fireman No. 1 closes the door of No. 4, and as soon as he has fired 6, 8, and 10, and trimmed 7 and 9 he sits down.

And so it goes on like clockwork. Nobody has to be told when it is his turn, there is no bossing, nagging, nor bawling; the men work easily and systematically; there are never more than two doors open in the group at a time—that into which the man is shoveling, and that of the furnace which is being trimmed. The firing of alternate doors at considerable intervals insures that one side of each furnace shall be full of white-hot coal to burn the volatile matter from the fresh fuel fired to the other side, and the fire is carried some 14 inches in thickness all over the grates, giving no chance for air to get through without losing its oxygen to the white-hot carbon. If the load is light and coal is not being burned so fast but that the fires thicken up above 16 inches, under this treatment the number of scoops of coal per firing is reduced; but the stokers can get around fast enough so that nine scoopfuls at a time will supply all the coal the boilers will use at the greatest rate that they are ever driven.

At most boiler plants it is customary to use dampers and hold the steam pressure within a pound or so, but at this plant, instead of doing this, the men try to keep the air supply so it will burn the coal. Mr. Diman's argument is, that when the steam pressure becomes too high and the damper shuts off, the air supply is insufficient to burn the carbon of the coal to more than carbon monoxide, producing 4,450 British thermal units per pound of carbon, instead of burning it to carbon dioxide that furnishes 14,500 British thermal units per pound carbon. The loss due to dropping the steam pressure 15 pounds is not so much as dropping the percentage of carbon dioxide from 14 down to 8 by imperfect combustion.

Mr. Diman shows the loss due to incomplete combustion resulting in a low carbon dioxide CO₂ chimney gas on every \$1,000 worth of coal burned in Table III.

With the use of Sturtevant exhaust fans the exhaust over the fire runs from .3-inch water gauge when the boiler pressure is highest to about .6 inch when the pressure is down, but even

then enough air comes through the coal to burn it to carbon dioxide, and not enough to give an excess of air.

The fans have stops on the valves that control them, and when the fires are in good condition the amount of come and go will keep the pressure fairly regular under ordinary working conditions. Another fallacy discarded at this plant relates

TABLE III. LOSS BY INCOMPLETE COMBUSTION PER \$1,000 WORTH OF COAL BURNED

Percentage of CO ₂	Loss Per Cent.	Loss, Dollars
14	No loss	
13	1½	15
12	2½	25
11	4½	45
10	6	60
9	8½	85
8	11	110
7	15	150
6	19½	195
5	26½	265
4	32	320
3	53½	535

to the idea once generally prevailing that the more boilers one had and the slower they were fired, the better the economy, for then there was plenty of boiler surface to soak up the heat that might otherwise go up the chimney. This arrangement prevents the fires being run hot and therefore a quantity of gas is lost. At the American Woolen Mill plant the furnaces are pushed to get all there is out of the coal, burn the gas hot and take out by an economizer what heat the boiler does not absorb. Ordinarily the boilers furnish steam with less than 6-inch water gauge, but after the fires have been running some time this draft will not force air enough through them, and when the steam falls 15 pounds the whistle blows automatically and everybody goes to slicing.

The tall chimneys that have been erected to create draft are, according to Mr. Diman, destined to be discarded. There is no question but that there is some ratio between the area of the grate and the area of a chimney, but since thickness of the fire, wind, and weather influence the draft, recourse is had to large high stacks, and then if the boiler plant is much increased, to still larger and higher stacks. The draft produced by chimneys depends upon the difference in pressure between a column of cool air outside and a column of hot air inside the chimney. It follows from this that the hotter the air inside the chimney the better the draft will be for any given sized chimney. At the American Woolen Co. plant, where the gas going up the stack is 200° F., a temperature probably lower than at any other boiler plant, there is a saving of more than 7 per cent. in heat, and this more than pays for the steam required to run the exhaust fans used to induce draft. It makes little difference what the weather may be, the fans furnish a sure draft independent of weather conditions and can be made to respond quickly to the demands of the engines for power.

乘 乘

Petroleum in Borneo is contained in regular occurrences of oil belts of narrow width but of great length, and the oil indications in British North Borneo coincide with remarkable similarity with those existing on the east coast oil fields, which induced the successful Shell Company to make their first trial borings. In both parts of the island the same geological conditions prevail, the oil being found in the Tertiary formation of the Miocene period, which contains the rich oil-bearing strata of this country. The oil here is associated with enormous gas pressure, most of the wells starting as gushers, the oil being generally contained in sandstone, as stated in a recent United States Consular Report. The petroleum-bearing lands of British North Borneo are those on which the most recent attention has been fixed, and they are, from geological and other indications, believed to bear an intimate relationship with and be closely allied to the deposits of Dutch Borneo.

Coal Combustion Recorders

The following paper was presented by Prof. Augustus H. Gill before the Congress of Technology at the Fiftieth Anniversary of the granting of the charter of the Massachusetts Institute of Technology:

By the simple determination of the carbonic acid content and temperature of the gases from a boiler furnace, its efficiency can be closely determined. By the investment of 10 dollars in premiums to keep the CO_2 at 12 per cent., an electric company in a Massachusetts city saved 40 tons of coal. This would seem to demand the attention of every manufacturer using coal.

The first analyses of chimney gases were made in 1827 by Beclét; they were sampled by emptying a bottle of water in the gases, and he found that in ordinary combustion only about half of the air was used. Bunsen in 1839 analyzed the gases from a blast furnace in Vackershagen and found that over 40 per cent. of the fuel was wasted; attempts were made to use this waste heat for raising steam. The analyses in those days were tedious and troublesome, a whole day being employed in taking a sample. Scheurer Kestner used 10 gallons of mercury and complicated trains of combustion and absorption apparatus. Now a result is obtained in five minutes and recorded—all automatically.

The first portable apparatus for gas analysis was devised in 1872 by Clemens Winkler, the discoverer of the rare element germanium. This apparatus, however, is troublesome to manipulate, is not jacketed, and hence unsuitable to the drafty boiler room. It, however, served a useful purpose in preparing the way for the Orsat apparatus, patented in 1873, and by October, 1874, found its way into more than 50 factories in all parts of Europe and even in America. It was used wherever carbon dioxide was generated—with all sorts of furnaces—puddling, melting, Bessemer, Siemens-Martin, boilers, gas producers, fermentation industries, beet sugar factories, sulphuric acid and alkali works.

The chimney gas to be tested is collected and measured over water or brine in a burette and successively forced into various absorbents contained in pipettes. The diminution in volume represents the percentage of the different constituents. The operation is done by hand and requires nearly a half hour for its completion. Three gases are determined, one of them carbonic oxide, indicative of imperfect combustion, which is shown by no other apparatus. The apparatus has the disadvantage of indicating what is transpiring in the furnace only at the time at which the sample was taken—a very brief interval—two or three minutes at most. Furthermore it requires an attendant to operate it. Its indications were so valuable, however, as to create the desire for an automatic device which should show the condition of the boiler furnace the same as the steam gauge shows the pressure. The first of these automatic devices was patented in England, in July, 1892, by Custodis and Duerr, of Munich. It consisted of a balanced glass globe suspended in a case into which the gas to be tested was drawn, and was a modification of the Lux gas balance. This invention was quickly followed by Arndt in September, 1892. Custodis and Duerr in 1895, then improved their first balance by adding another globe and making it recording.

This balance type of apparatus being constantly in motion resulted in the knife edges and planes wearing, thereby rendering it less sensitive, besides requiring frequent repair and adjustment. This type of recorder was superseded by the absorption apparatus of Arndt, in Achen, who received a patent in England, in December, 1896, for his "Ados" or heating-effect meter. Other patentees are Cederberg, of Denver; Simmance Abady, of London; J. C. Eckhardt, of Stuttgart; Sarco Fuel-Saving and Engineering Co., of New York; Uhling & Steinhart, of Newark; Salan & Birkholz, of Essen; G. Van Gilnert & Co., of Düsseldorf; and Hugh K. Moore, M. I. T. '97, Berlin, N. H. With these automatic devices usually a small stream of water

furnishes the power to draw a current of gas from the uptake or chimney into a floating gasometer and force it through potassium hydrate into another gasometer which is connected with a recording device that shows the amount of carbonic acid absorbed.

This should be about 13 per cent., for if a greater percentage be obtained, the loss by the formation of carbonic oxide usually more than compensates for the increase due to carbon dioxide. A percentage greater than 13 means that the fires are too thick. A percentage less than 10 means either that the fires are too thin or there is leakage through the bricks themselves which form the setting or through cracks therein. In many cases this is sufficient to reduce the CO_2 percentage to 5 or 7 which means a total loss of from 36 to 26 per cent. of the fuel, or from 22 to 12 per cent. more than should be lost, or otherwise expressed it means nearly 5 to 2 tons of coal in every 20.

The percentage excess of air and percentage lost heat with the gases escaping at 518° F. for various percentages of CO_2 in the gases is as follows:

Per Cent. CO_2	Excess Air	Loss of Heat	Per Cent. CO_2	Excess Air	Loss of Heat
2	850	90	10	90	18
3	530	60	11	70	16
4	370	45	12	60	15
5	280	36	13	50	14
6	220	30	14	40	13
7	170	26	15	30	12
8	140	23	16	20	10
9	110	20			

Nor are these apparatuses solely applicable to the regulation of combustion; wherever an absorbable gas such as sulphurous or hydrochloric acid or chlorine is evolved an apparatus to suit the circumstances can be installed. This will permit of increased control of chemical operations and consequently increased economy.

來 來

Tin Plate in Trade of the United States, 1911

Tin plate makes a new record in two or three important particulars in the commerce of the United States for the fiscal year just ended. The imports are lower than in any year since the record of its importation was begun, the outward movement of American tin plate was larger than ever before, and the shipment of domestic tin plate out of continental United States for the first time exceeded the imports of foreign tin plate.

During 1892, the first full year for which figures are available, the production amounted to 42,000,000 pounds. In 1909, the last year for which figures are available, the production amounted to 1,371,000,000 pounds. In 1910 exports to foreign countries were slightly over 26,000,000 pounds and shipments to non-contiguous territory 34,750,000 pounds.

For the 11 months ending with May, 1911, the latest period for which figures are available, the exports to foreign countries amounted to 60,887,040 pounds, valued at \$2,161,472, and shipments to non-contiguous territory 38,348,830 pounds, valued at \$1,673,934, making total shipments from the United States for the 11 months period of 99,333,000 pounds, valued at \$3,835,406, while for the same period the imports amounted to 91,557,586 pounds, valued at \$2,892,149, thus showing an excess of shipments of domestic tin plate over imports for the 11 months period of 7,687,284 pounds.

The large shipments of tin plate to non-contiguous territory are chiefly on account of the fish canning industry in Alaska, and fruit canning in Hawaii. The receipts of canned salmon from Alaska amounted to 107,639,801 pounds in the 11 months ended May, 1911, and receipts of canned fruits from Hawaii amounted to \$1,983,000 for the same period, practically all of which was packed in cans manufactured from American tin plate.

Answers to Examination Questions

Pennsylvania Anthracite Mine Inspectors, Scranton, May 25, 26, 1911; and Utah Mine Foremen

(Continued from August)

QUES. 32.—Why is the air at the surface of the earth more dense than that above the surface?

ANS.—The density of air and gases increases with the pressure, which is greater at the surface than above, owing to the weight of the upper air resting upon the air below. Atmospheric pressure decreases and the density of the air decreases the higher one ascends above the surface of the earth.

QUES. 33.—If powder smoke requires 2 minutes and 17 seconds to travel 149 yards in an airway 12 ft. × 19 ft., what quantity of air per minute is passing through that airway?

ANS.—The observed velocity of the powder smoke is $60 \left(\frac{149 \times 3}{2 \times 60 + 17} \right) = 195.8$ feet per minute. The average velocity of the air-current may be assumed to be, for a timbered airway, say eight-tenths of the observed velocity in the center of the entry; or, in this case, $.8 \times 195.8 = 156.6$ feet per minute. The area of the airway is $12 \times 19 = 228$ square feet, and the quantity of air passing is therefore $156.6 \times 228 =$ say, 35,700 cubic feet per minute.

QUES. 34.—What is the equivalent of a horsepower?

ANS.—In mechanics, 33,000 foot-pounds per minute, or about 2,545 British thermal units (B. T. U.) per hour. In boiler practice, the standard adopted to express a boiler horsepower is the evaporation of 34.5 pounds of water at a temperature of 212° F., into steam of the same temperature. In electrical work, the equivalent of a horsepower is 746 watts; the watt being the unit of electrical, or the power of a current of 1 ampere flowing under a pressure of 1 volt.

QUES. 35.—What is the increase of depth in the earth's strata for each degree of increase in temperature?

ANS.—The increase of temperature in the earth's strata varies in different localities and is not exactly proportional to the depth below the surface in the same locality. The average rate of increase of temperature in relation to depth below the surface, however, may be taken as 1° F. for each 60 feet of depth.

QUES. 36.—What is the decrease of pressure in pounds per square inch corresponding to a barometric fall of 1 inch?

ANS.—The corresponding fall in pressure is exactly equal to the weight of a cubic inch of mercury, or .4911 pound per square inch.

QUES. 37.—What is the difference in altitude of two places where the readings of the barometer are 29.1 and 27.8 inches, respectively?

ANS.—Assuming these readings were taken about simultaneously and not too far apart, the difference in altitude may be calculated very closely by first finding the average barometric pressure $\frac{1}{2}(29.1 + 27.8) = 28.45$. Now, taking the average temperature for the two places at the time of observation as, say 56° F., find the weight of a cubic foot of air at this temperature and pressure; thus, $w = \frac{1.3273 \times 28.45}{460 + 56} = .0732$.

This weight of air causes a pressure per square inch for each foot of height, $.0732 \div 144 = .000508$ pound. The difference of pressure between the two places is $.4911 (29.1 - 27.8) = .63843$ pound. The difference in altitude is then $.63843 \div .000508 = 1,256$ feet. A rule of thumb often used allows 900 feet of vertical distance for each inch of barometric difference; or, in this case, $900 (29.1 - 27.8) = 1,170$ feet. This rule, however, applies better to readings below sea level, as in finding the depth of a shaft.

QUES. 38.—How much coal would there be in a tract of 250 acres, the vein being 22 feet and pitching 50 degrees?

ANS.—On this pitch, the given acreage corresponds to an area of $250 \div \cos 50^\circ = 250 \div .64279 = 388$ acres in the seam. It is customary to allow 100 tons per inch-acre as the possible extraction of coal; or in this case $100 \times 388 (22 \div 12) = 10,243,200$ short tons. This is a low estimate, at the present time, for anthracite mining.

QUES. 39.—What lesson may be learned from the Pancoast disaster?

ANS.—The chief lessons taught by this disaster are the following: (1) Build underground engine rooms wholly of incombustible material. (2) Use electricity for lighting instead of oil. (3) Never leave an engine room, pump room, stable, or other place in a mine where machinery is located, or any material or supplies are stored, unprotected or unguarded. Places so left should be locked securely by the person having the same in charge. (4) Instruct every worker in the mine how to get out by escapeways other than those in common use, and make all men use these means of exit frequently to insure their acquaintance with the same. (5) Place conspicuous signboards at all road junctures to point the way out; shape the boards so as to indicate the direction to be taken by feeling the board in the dark. (6) Arrange the best possible service in answering phone calls in the mine, and make a special ring the alarm signal to hurry all men out of the mine.

SELECTED QUESTIONS OF THE UTAH MINE FOREMEN'S EXAMINATIONS HELD IN CARBON COUNTY FEBRUARY 21, 22, 1911

NOTE.—Questions relating to the mining law have been omitted for the reason that they are readily answered by reference to the state mining law of Utah, a copy of which should be in the hands of every mining man.

QUES. 4.—Do you receive and read any instructive literature pertaining to the various systems of coal mining, and the requirements of safety in the operation of coal mines? What magazines of this kind do you take?

REMARK.—This question (to be answered by the candidate) is repeated here as being an exceptional style of question, and showing a proper desire on the part of the examiners to ascertain the amount of personal interest the candidate takes in mining matters and the study of mining conditions.

QUES. 7.—In your daily examination of the mine what four points of interest to miners, relating to the condition of their working places, would you watch?

ANS.—(1) The timbering of the roof and taking down promptly loose rock. (2) The mining and timbering of the coal face. (3) The manner of placing, charging, and firing holes in blasting the coal. (4) The manner of loading the coal, and cleaning up the working face, disposal of the waste and fine coal.

QUES. 9.—In your opinion, can sufficient water sprays be placed in the intake airways of a mine to so saturate the intake air that all coal dust in working places and travelingways will be dampened? State why.

ANS.—No. Because the air-current, though completely saturated with moisture by the water sprays, does not give up its moisture except there is a fall of temperature, which does not usually occur at the working face and elsewhere in the mine where dust accumulates; and, for the further reason, that more water is required to dampen the dust accumulations in mines than is commonly deposited at the working face by the air-current under the most favorable conditions.

QUES. 11.—Describe the use of the barometer in mining.

ANS.—The rise and fall of the mercury in the barometer shows the rise and fall of the atmospheric pressure. A sudden fall of pressure is accompanied by a corresponding expansion of the air and gases filling the void and abandoned places in the mine, with the result that the mine passageways and workings often become filled with gas; and it is necessary to increase the circulation or warn and perhaps withdraw the men. The aneroid barometer is much used to determine the relative elevation of different points on the surface.

QUES. 12.—When the barometer reads 23.20 inches, what is the pressure of the atmosphere (a) per square inch; (b) per square foot?

ANS.—The pressure is: (a) $.4911 \times 23.2 = 11.3935$ pounds per square inch; and (b) $11.3935 \times 144 = 1640.664$ pounds per square foot.

QUES. 13.—Explain the difference in the methods of producing an air-current by a force fan and by an exhaust fan.

ANS.—Assuming a centrifugal fan, the action of the fan is the same in each case, air being drawn in at the center and discharged at the circumference of the fan. The difference between a force fan and an exhaust fan lies wholly in the manner in which the fan is connected with the mine. A force fan is open to the atmosphere at the center, while its discharge at the circumference is connected with the mine. On the other hand, an exhaust fan has its central openings connected with the mine and discharges its air through a chimney into the atmosphere. In the former case the mine pressure is above that of the atmosphere, while in the latter case it is lower than the same.

QUES. 14.—Would there be a gain or loss in placing a stack of the same dimensions as the outlet of a fan and, say 50 feet high, so that the fan would discharge into the stack?

ANS.—For the same speed the fan would discharge less air and consume less power. The efficiency would be less as the fan would have to be run at a higher speed to produce the same quantity of air. The result would be a loss.

QUES. 15.—Describe the construction and uses of the water gauge and anemometer.

ANS.—The water gauge is a U-shaped glass tube, having both ends open and mounted on a wooden block. One end of the tube is longer than the other and bent at right angles so that it can be inserted in a hole in a brattice or partition, thus permitting the air pressure on the other side of the brattice to act on the water in that arm of the tube while the water in the other arm is exposed to the air pressure on this side of the brattice. The water level falls in one arm and rises an equal amount in the other. The difference between these two levels, as measured by the scale in inches, indicates the difference of air pressure on the two sides of the brattice. The anemometer is a vane with inclined blades mounted on an axis so as to revolve. A central dial registers the number of revolutions of the vane, each revolution corresponding to a single foot of air travel. By exposing this instrument in an air-current for 1 or more minutes and reading the dial the velocity of the current can be ascertained.

QUES. 16.—What pressure per square foot does a water-gauge reading of 1.85 inches indicate?

ANS.—The pressure is $1.85 \times 5.2 = 9.62$ pounds per square foot.

QUES. 17.—What is the total ventilating pressure in an airway 6 ft. \times 7 ft. when the water-gauge reading is .5 inch?

ANS.—The unit of ventilating pressure is $.5 \times 5.2 = 2.6$ pounds per square foot. The sectional area of the airway is $6 \times 7 = 42$ square feet; and the total ventilating pressure is then $42 \times 2.6 = 109.2$ pounds.

QUES. 18.—An airway is 8 feet 6 inches wide at the floor, 9 feet 6 inches wide at the roof, and 8 feet high. The anemometer registers 1,125 revolutions per minute; what amount of air is passing?

ANS.—The average width of the airway is $(8.5 + 9.5) \div 2 = 9$ feet; and the sectional area $8 \times 9 = 72$ square feet. Assuming the reading of the anemometer is the average velocity of the air-current at this point in the airway, the volume of air passing is $1,125 \times 72 = 81,000$ cubic feet per minute.

QUES. 19.—Given a gangway 8 ft. \times 10 ft. and 1,200 feet long, the pressure indicated by the water gauge being 2 pounds, and the air having a velocity of 500 feet per minute, what is the water-gauge reading, the quantity of air passing per minute, and the horsepower?

ANS.—Taking the coefficient of friction as $k = .00000002$, the calculated unit of ventilating pressure for this airway would be

$$p = \frac{k l o v^2}{a} = \frac{.00000002 \times 1,200 \times 36 \times 500^2}{80} = 2.7 \text{ lb. per sq. ft.}$$

However, the water gauge corresponding to a pressure of 2 pounds per square foot, as given in the question, is $2 \div 5.2 = .38$ inch. The quantity of air passing is $80 \times 500 = 40,000$ cubic feet per minute. The horsepower on the air is then

$$H = \frac{Q p}{33,000} = \frac{40,000 \times 2}{33,000} = 2.424 \text{ H. P.}$$

QUES. 20.—What is a dumb drift? Explain its object and show by a sketch its position in relation to the furnace.

ANS.—A dumb drift is an air-passage driven from a point on the main return airway, inby of the furnace, to a point in the upcast shaft above the reach of the flame or sparks arising from the furnace, as shown in Fig. 1. The furnace *f* is fed by a small scale of fresh air taken from the intake through the regulators at *a*; while the main return current is prevented from passing over the furnace by the stopping built at *b*, by which the current is made to pass through the dumb drift. The object is to prevent the ignition of the mine gases in the return current by the furnace fire.

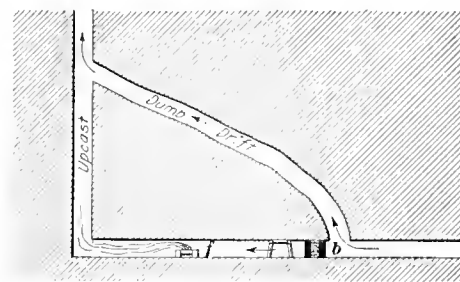
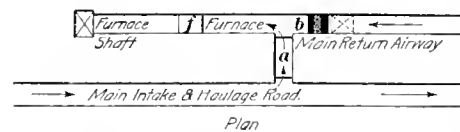

FIG. 1

QUES. 21.—Explain the principle of natural ventilation.

ANS.—The natural heat of the mine coming from the strata and arising also from the presence of men and animals, the burning of lamps, combustion of fine coal in the waste, etc., heats the mine air; so that the return current usually has a higher temperature than the intake current. This increase of temperature causes an air column to form in the mine entries running to the rise or dip, and in all slopes and shafts, because the warm air of the mine is lighter than the cooler outside air traveling on the intake. The difference in the weight or density of the air causes a ventilating pressure that produces natural ventilation.

QUES. 22.—(a) What is meant by the friction in airways? What is (b) the perimeter; (c) the sectional area; and (d) the rubbing surface of an airway 10 ft. \times 12 ft., 5,000 feet long?

ANS.—(a) Friction in mine ventilation is the resistance offered by the mine to the passage of the air-current; it is due to the rubbing of the air along the sides, roof, and floor of the airways, and to the obstruction of the air passages by timber, roof falls, cars, etc., and the sharp bends or turns in the course the air is made to travel by the placing of doors, brattices, curtains, etc. (b) Perimeter is $2(10 + 12) = 44$ feet. (c) Sectional area is $10 \times 12 = 120$ square feet. (d) Rubbing surface is $44 \times 5,000 = 220,000$ square feet.

ORE MINING AND METALLURGY

The Cornwall, Pa., Magnetite Deposits

Description of a Remarkable Body of Ore and the Methods of Mining and Handling It.

That there has been considerable speculation over the genesis of the Cornwall magnetite deposit in Lebanon County, Pa., is due to its structure, composition, and geological surroundings differing materially from the magnetite deposits of New Jersey and New York.

Persifer Frazer, Jr.,* in Vol. V of the Transactions of the American Institute of Mining Engineers, says: "It is not quite certain how much of the magnetic particles with which these ores are mixed may have come from the trap itself. * * * It is likely that much is to be ascribed to this source; but, however that may be, it cannot but be of the greatest significance that the two plates of trap which occur near these mines inclose or cover the greater number of producing deposits."

The foot-wall of the Cornwall ore deposits is trap rock approximating basalt, that forms a kind of basin in which the ore is found. The hanging wall or cover immediately above the ore to the south of Middle Hill mine is limestone, and through this there is a nearly vertical trap dike that places the age of the former as older than the latter. As the country rocks are sedimentary it is not difficult to understand that they would naturally be shattered and fissured by the intrusion of the trap rock, and that the mineral solutions which accompanied the intrusion and continued for some time afterward would circulate through the fissures. It is presumed therefore that these deposits were formed by replacement and are not of magmatic origin as are the magne-

tite deposits of New Jersey and New York. This hypothesis is based on the fact that there is an almost horizontal bedding of the ore which indicates that stratification antedates the formation of the ore, in fact limestone is found alternating with thin streaks of ore that give the whole a banded and often a serpentinized appearance. On Grassy Hill there is a limestone outcrop that is covered with decomposed buff-colored clay that

resembles the clay covering of limonite deposits. Traditional reports state that considerable red hematite was mined from one part of this hill, while to the north and west, adjacent to the trap wall, the greenish black magnetic ore was mined.

According to E. V. D'In-villiers, who, after a careful study and examination of the deposits wrote a monograph for the Second Geological Survey of Pennsylvania, "the original formation was made up probably of lime shales containing magnesia, silica, alumina, and iron pyrites. This probability is increased by the bedded and laminated

stratification, and it is converted into a certainty by the fact that a considerable thickness of unchanged lime shale layers, passing upwards into solid beds of hard limestone, show themselves near the southern side of Middle Hill mine in the body of the ore mass. These unchanged lime shales at one place are seen resting upon the ore; at another place the limestone beds dip under the ore layers at the same angle and apparently change gradually into ore."

Conditions so far as exploitation goes have changed somewhat since Mr. D'In-villiers' inspection of Middle Hill. Serpentine and other magnesian silicates are found near the junction of the limestone and particularly near the dike, which points rather conclusively to the alteration coming from solutions that were capable of metamorphosing the limestone.

It is possible that the Corn-



FIG. 1. CORNWALL ORE MINES
No. 1 Steam Hoist to right; Robeson Hoist in center near tracks; No. 2 Hoist and Substation on hill; Ore Bin and Stock Pile in middle.



[FIG. 2. OPEN CUT WORKINGS IN MIDDLE HILL

*Vol. V, Trans. A. I. M. E., page 142.

wall deposits, since they are not magnetite magmas like those of New Jersey and New York, may have been formed in one of two ways by the ascending thermal solutions: First, the deposits may have been a hematite mass that was changed by the solutions into a magnetic mass. Second, the deposit may have been limestone, or such as D'Inwilliers describes, that was changed by solutions, in either case it is assumed on good grounds to have been formed by ascending solutions.



FIG. 3. STEAM SHOVEL LOADING IRON ORE

Dana, in his *System of Geology*, says: "Deville formed crystals of magnetite artificially by the action of hydrochloric acid on heated ferric oxide; and also by the decomposition of ferric oxide with boracic acid."

Prof. Thomas A. Eggleston, in Vol. V, page 131, of the *Transactions of the American Institute of Mining Engineers*, says that "some of the hematite ores of Lake Superior contain boracic acid," and he gave the following instructions for its identification:

"Pulverize, calcine, and moisten the pulp with sulphuric acid. Heat some of the mass on a platinum wire to expel the sulphuric acid, then moisten with glycerine, and flame. If boracic acid is present it will infallibly give a green flame." This ore gives a green flame, but it may be due to copper, which also gives a green flame.

The structure of the Middle Hill ore is mostly massive, with small pit marks here and there containing small crystals of magnetite, and through the ground mass, pyrite, chalcopyrite, and other minerals are found. D'Inwilliers mentions 25 different kinds of minerals as being found at these mines, the copper minerals being a cuprous variety of pyrite, chalcopyrite, covellite, cuprite, hydrocuprite, chrysocalla, malachite, and azurite. No analysis of the ore is free from copper. At one time copper was mined as a commercial proposition, approximately \$175,000 worth being sold. This was mostly green and blue carbonates and chalcopyrite.

The gangue of the ore is sand, which in places seems to be laminated. The sand is fine and light colored, showing it has been leached, and frequently it appears in small thin folds and contortions like the various layers of hornblende, mica, and quartz in gneiss.

This indicates that acid solutions displaced the limestone, and the sand particles, being insoluble, segregated as found.

Mining operations are said to have commenced at Cornwall in 1740, which is 16 years earlier than at the Forest of Deans mine near Fort Montgomery, in New York state. Tradition states that artillery was made for the Continental army at the old Cornwall furnace.

From the three deposits in Big Hill, Middle Hill, and Grassy Hill over 20,000,000 tons of ore have been removed. The greatest quantity mined in one year was approximately \$35,000 tons; however, with the present facilities this no doubt could be

increased to 1,000,000 tons, if there was such a demand for the ore. The Lackawanna Steel Co. and the Pennsylvania Steel Co. are the principal consumers, the market for the ore being narrowed by its low tenor in metallic iron and its high sulphur. The ore, when exposed to the weather, is oxidized to some extent, and loses some sulphur. However, before being charged in a blast furnace it is roasted. An analysis of the ore in percentages is as follows: Silica, 15; alumina, 4; lime, 3.5; magnesia, 5.5; metallic iron, 48; sulphur, 3.5. After it is roasted in Giers kilns the sulphur is reduced to about 1.07 per cent., and in this condition it is possible to smelt Bessemer pig owing to the extremely low phosphorus contents.

Ore is roasted in Colby furnaces very successfully with blast furnace gas by the Pennsylvania Steel Co.

In Fig. 2 is shown the open-cut workings in Middle Hill, taken from Big Hill in the foreground, which is practically worked out. Between Big Hill and Middle Hill the railroad tracks are supported on ore left there for that purpose. This view, although taken in 1908, does not materially differ from the conditions governing the mines today, although there have been a number of important surface improvements. Grassy Hill mine is to the rear and right of Middle Hill mine and does not show in the illustration.

The Middle Hill mine has been worked to a depth of 150 feet for approximately a half of a mile; however, there is a considerably greater area to be stripped and exploited besides 150 feet more depth before the bottom of the deposit is reached. In the process of mining, a comparatively light cover of soil and rock is removed, as shown in Fig. 3 on the top bench above the steam shovel. The removal is accomplished by putting down a series of drill holes, then chambering or bulling them, and finally loading and firing them with a battery. The cover is thus broken in sizes that the steam shovel can readily load into dump cars. When the cover has been removed a wide bench of ore remains that can be broken so that it falls to the bench on which the steam shovel is working, shown in Fig. 3. In this way there has been formed a series of four stopes or benches from which ore is mined. Fig. 4 shows a steam shovel on the floor of the third stope on the foot-wall side of the mine. The locomotive zigzags with the loaded cars from the lower to the upper stopes, although on the present main level the ore is delivered in 50-ton cars to the incline of the crushing and screen-



FIG. 4. STEAM SHOVEL AND ORE CAR ON THIRD STOPE

ing plant. The ore car shown attached to the locomotive in Fig. 4 is a 50-ton car which dumps into a steel-foot frame pocket. To break down the ore it has been customary to put down a series of 18- to 24-foot drill holes with air drills on each bench, then charge and shoot the holes simultaneously. In this way a quantity of broken ore can be kept ahead of the steam shovels. Recently two small traction well-drilling machines have been installed to put down holes where depth greater than the air

drills can furnish is desired. These are worked on benches ahead of the steam shovels, and although slower than air drills, their holes, being larger and deeper, probably even up the quantity of material broken over a given time. The ore broken from the stopes falls in all sizes, making it necessary to block hole extra large pieces and "block blister" smaller and more suitably shaped pieces. To "block blister," a piece of dynamite has a cap and fuse attached in the usual way, after which it is placed on the ore to be broken and covered with loose dirt. The dynamite, when exploded, breaks up the material into pieces that can be scooped up by the steam shovels, although that machine delivers pieces weighing 3 or 4 tons at times into the cars.

The extreme eastern hoist at the foot of Big Hill is known as hoist No. 1 of the Cornwall Ore Banks Co. This is operated by steam but is at present closed down. Ore from the Big Hill basin is taken through tunnels to the Cornwall Ore Banks Co.'s No. 2 hoist operated by electricity.

While a large tonnage of ore could be removed from the west end of the Middle Hill mine by cars attached to locomotives, at the present time all ore is hoisted at the eastern end of the Middle Hill mine up two inclines. At this end of the mine it is necessary to sink in order to form a stope that can be carried the length of the mine, and this stope, which is from 40 to 60 feet high is worked at right angles to the length, that is, the width, for about 400 feet.

The eastern incline in Middle Hill mine, shown in Fig. 5, is operated by the Robeson Iron Co., who have the right to mine sufficient ore for one furnace only. This company loads ore directly into skip cars which are hauled by mules over several tracks on the main level to the steam hoist where they are hooked to the cable and hoisted from the pit.

At the top the ore is dumped directly into chutes that load the broad-gauge cars. This arrangement necessitates loading cars by hand and sledging up pieces of ore so the men can handle them. However, when in this condition the product is about ready for the furnace. Attention is called to the trap dike to the left of the incline, and to the small quantity of rock in this deep pit.

To the west of the Robesonia incline is a second, or No. 2, incline, shown in Fig. 6, which was constructed in 1909. This is a most interesting installation, consisting of a steel foot frame, combined with crusher and skip-loading bin, and a steel



FIG. 5. EASTERN INCLINE, MIDDLE HILL MINE

head-frame combined with crushing, screening, and transfer arrangements. The foot-frame is 20 ft. x 30 ft. x 70 1/2 ft., and is covered, as shown in the illustration. The large 50-ton ore cars when loaded are run into the shed above the frame and dumped into a large hopper which, in Fig. 7, is termed an 85-ton grizzly. Whatever is small enough to pass through the grizzly bars falls into the 100-ton pocket from which the skip is loaded; but whatever passes over them is fed by a 9-foot rotary drum

to a 60" x 42" Farrel jaw rock crusher. This machine will receive a piece of ore weighing 4 or 5 tons and crush it to 12-inch sizes. To work this crusher it requires 150-horsepower, 25-cycle, three-phase Westinghouse induction motor, making 860 revolutions per minute at 440 volts and 210 amperes. The feed-drum to the crusher sometimes becomes clogged by ore jamming, in which case if the pieces are large and cannot be started by bars, they are blasted. Occasionally a large piece of ore will fall over



FIG. 6. NO. 2, INCLINE AND SKIP-LOADING BIN

the mouth of the crusher in such a way as to lodge. To turn this so as to insert it in the jaws a compressed-air hoisting crane, installed for this purpose, is brought into use. The ore from the crusher falls to the 100-ton ore bin, where it joins the material that passed the grizzly. The ore from this bin is loaded into 10-ton iron skips by means of 6-foot diameter roller feeds. Along the foot-wall above the pit there is a water basin or ditch excavated, which catches the water from the foot-wall and leads it to a brook so that it does not enter the pit. It is only in times of thaws or heavy rains that water is plentiful in the slope sumps, and this is cared for by steam and electric pumps. The hoisting engineer is down in the foot-frame where he can see to the loading of the skip; in fact, he controls the motors that rotate the drums. However, he has an assistant who opens and closes the chute gates to the skips. The hoisting is done on two tracks by 10-ton skips attached to 1 1/2-inch steel ropes that are wound on drums driven by electric motors. To hoist, the engineer moves a master switch to the right or left, and as the skip nears the dump at the head-frame, the power is automatically gradually shut off. As the dump is reached, the power is entirely turned off and the air brake goes on. At this point the skip is discharged and held by compressed air until the engineer releases it by reversing the lever. An end view of the crushing and screening plant attached to the head-frame is shown in Fig. 8. In this plant, motor-driven rolls and screens crush and size the ore previous to its being transferred by a 50-ton electric dump car to the 2,500-ton loading pockets, or 35,000-ton capacity stock-pile trestle. At the pockets the 5-foot roller feed-gates can load a 45-ton car in 4 minutes, including spotting and delivering to the railroad company's tracks. The ore from the stock pile is loaded by steam shovel into railroad cars in case there should be a temporary cessation of hoisting for any purpose. The head-frame, loading pockets, and stock trestle are connected by a steel viaduct which passes over the several railroad tracks, as shown in Fig. 1. The electric power for the various machines is generated at Lebanon, about 6 miles away from the Cornwall ore bank. At Lebanon a furnace belonging to the Pennsylvania Steel Co. has a Semet-Solvay by-product coke-oven installation that supplies sufficient gas to run three twin Westinghouse gas engines, each of 1,200 horsepower, for the electric power needed at the mines. These gas engines run 3,750-kilowatt Westinghouse dynamos that generate current

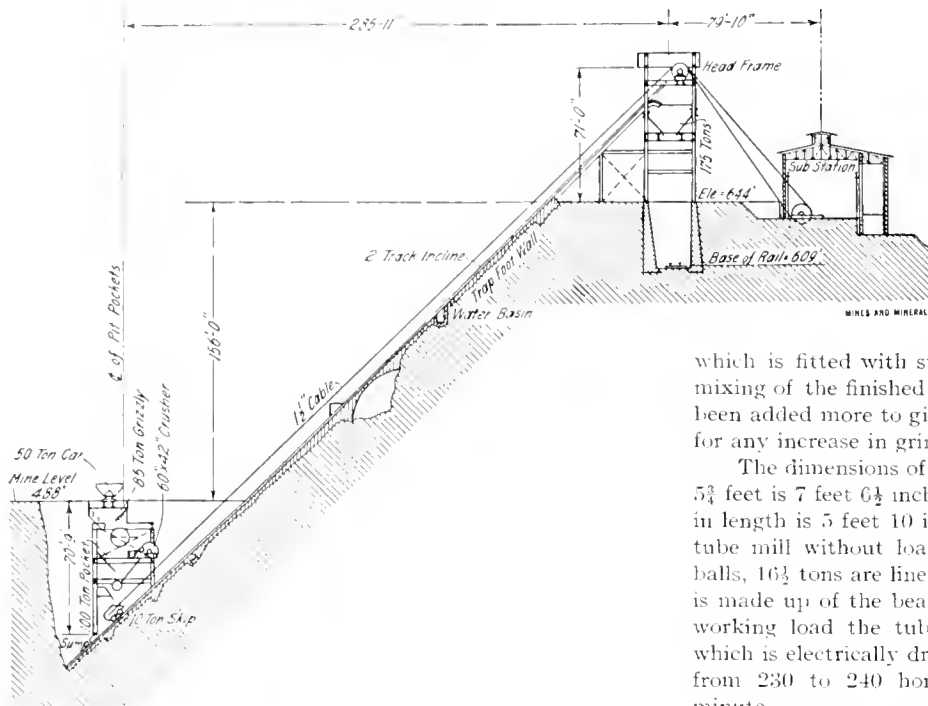

FIG. 7. SECTION THROUGH INCLINE

at 440 volts, which is raised to 11,000 volts for transmission to Cornwall. To the rear of No. 2 head-house is the substation where the current is stepped down to 440 volts for use in the various motors. To take care of the heavy peak load in the skip hoist, a rotary converter is provided to give direct current for the 500-horsepower hoisting motor. An electrically operated Ingersoll-Rand air compressor, furnishing 3,200 cubic feet of free air per minute, supplies 13 compressed-air drills and other labor-saving machines at the mine.

來 來

The Giesecke Tube Mill

By R. G. Mackie*

The Giesecke mill is a new tube mill introduced in the Transvaal, which has for its object the elimination of the gravity stamp; and in the experiment now being made, 50 stamps of the Geldenhuis estate are hung up, and the ore which ordinarily would have been supplied to them is going straight from the rock breakers, less the fines, of course, in sizes up to 7-inch diameter, and is coming away from the discharge end of the tube in a thick, smooth product of which nearly 81 per cent. passes a 200-mesh screen.

The consistency of the pulp is that of an emulsion carrying 28 per cent. of moisture. The mill itself has the appearance of an ordinary tube mill, except that a comparatively short length, less than one-third of the total length, which is about 24 feet, is over 2 feet greater in diameter than the rest of the barrel. The larger end of the mill, the feed end, does the first crushing, and is separated inside by a screen which prevents large particles escaping. The reduction work inside the mill is done by different sized steel balls falling on to a lining of iron plates about 2 feet in length, a foot wide, and 2 inches thick. One end of the plate is bolted to the shell of the mill so that the other end projects inwards about 9 inches from the inside of the tube surface. These liner plates overlap like the inverted leaves of the springs on vehicles.

The mill is charged with eight different sizes of steel spheres, varying in size from 4 inches in diameter to 1 1/4 inches, the four largest sizes being retained in the first compartment or break-

ing chamber of the tube. The smaller balls do the work in the smaller diameter but longer section of the tube. As the cubes of ore are passed into the tube by means of an automatic feeder, a water spray supplies all the water needed. The revolving of the cylinders causes crushing and grinding, and reduces every size and shape of stone in its travel to the outlet to a fineness and consistency almost like that of molasses. At the exit end of the tube is an elliptical shaped chamber

which is fitted with steel arms inside in order to obtain better mixing of the finished product; but this section of the mill has been added more to give a cyanide solution better contact than for any increase in grinding.

The dimensions of the tube mill are, length 24 feet, of which 5 3/4 feet is 7 feet 6 1/2 inches in diameter, and the remaining 17 feet in length is 5 feet 10 inches diameter. The total weight of the tube mill without load is 68 tons, of which 23 tons are steel balls, 16 1/2 tons are liners, 15 1/2 tons tube or shell, and the balance is made up of the bearing ends, wheels, etc. When carrying a working load the tube holds 50 tons of pulp, and the mill, which is electrically driven by a 400-horsepower motor, requires from 230 to 240 horsepower, the revolutions being 24 per minute.

The mill is now crushing about 360 tons of ore per day, and the last grading analysis, taken from ore sized above fines to 7 inches, showed sizes to be as follows: +60 mesh, .5; +90 mesh, 5.6; +120 mesh, 6.7; +200 mesh, 6.3; -200 mesh, 80.9. The water feed was 28 1/2 per cent. of the material fed to the mill.

One special feature of the mill is that its lubrication is automatic, inasmuch as it is claimed that the grease boxes filled with Canadian grease, which are fitted over the bearings, need no attention for months. The mill can be started or stopped with the greatest ease in 5 or 6 seconds, by merely throwing over the lever, which clutches in or out as desired. Once started, the work proceeds automatically, as the mill requires no attendants, and as the product emerges from the outlet it is merely a matter of pipes or pumps to deliver where required. There is one unknown detail which remains to be determined, and that is maintenance charges.

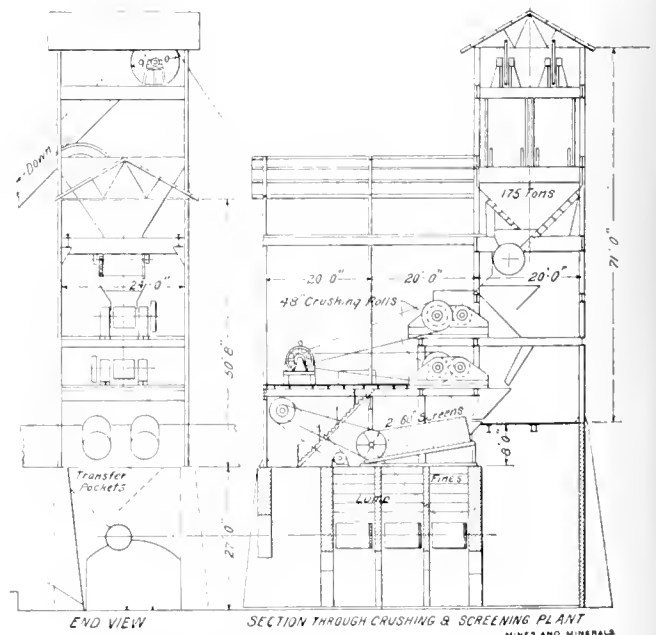

FIG. 8. END VIEW AND SECTION, ORE PREPARING PLANT

* Resident Engineer, Geldenhuis Deep, Ltd., Cleveland, Transvaal.

American Gem Mines and Mining

A Description of Some of the Mines of Tourmaline, Turquoise, Sapphire, Diamonds, Etc.

By John L. Cowan

According to the reports of the U. S. Geological Survey, the value of precious stones, in their rough condition, produced in the United States increased from \$208,000 in 1906 to \$534,380 in 1909. It is certain, however, that the actual value of gem materials produced in this country is much greater than is reported by mine owners. It appears to be their idea that the market price of their products would be depreciated if the real magnitude of the production were known; and they seek to create the idea that their specialties are scarce, and therefore precious, by reporting a small output.

Furthermore, the development of American gem mining has been hampered by the fact that there are practically no experienced prospectors in the field capable of knowing a valuable gem material when they see it. Prospectors with few exceptions, are in search of gold, silver, copper, or other metallic wealth, and pay no attention to shining stones or bright-colored pebbles. The outcrops of some of the greatest gem mines in America were known for decades, and the shining crystals used as toys by the children, before some one happened along with the knowledge to recognize them as something having a cash value, or the curiosity to find out just what they were. Another cause for the neglect of American gem mines and American gem materials has been the scarcity of competent lapidaries in this country, capable of cutting and polishing native gems in the most attractive manner. Still other reasons may be found in the enormous number and variety of cheap "fake" gems (usually of French glass) on the market, and in the overshadowing importance of the metal-mining industries, leaving little temptation to any one to engage in the little-known business of gem mining.

However, there are now indications that American gem mines will be developed in the future to a much greater extent than in the past. The figures quoted from the report of the Geological Survey, showing that the output of gem materials was

quantities of pink tourmaline. In addition to these considerations, there are now in the more important gem-producing regions, and in all the large cities, skilled lapidaries, capable of cutting and polishing any gem material known, in such a manner as to bring out all its latent beauty and show it off to the best possible advantage.

With the gradual rise of the American gem-mining industry to a position of at least local importance, it is natural that there



FIG. 2. HIMALAYA, CALIFORNIA, TOURMALINE MINE

should be some curiosity as to how the more notable gem mines have been found. It is true of these, to an even greater extent than of gold and silver mines, that their discovery has usually been the result of a lucky accident. At all times there are hundreds of prospectors in the field, looking for indications of the precious metals; but no one ever thinks of prospecting for precious stones—at least not until the first paying mine in a given region has been found. Few of the tribe of prospectors, in fact, possess the technical knowledge to distinguish a precious or semiprecious stone from a worthless quartz crystal or bit of agate or chalcedony.

The most famous gem-producing district in the United States is in Riverside and San Diego counties, Cal. On account of the variety, beauty, and abundance of gem materials discovered in this district within recent years, it is sometimes called the "American Kimberley." On Pala Mountain is a property that has excited interest and curiosity for 60 years or more. It first attracted the attention of an Indian deer hunter named Vensuelada, who is said to have shown it to a prospector named Henry Magee. The rock formation contained numerous opaque pink crystals of tourmaline, which Magee thought must be cinnabar. So he located a quicksilver mine, and did considerable development work.

Assayers assured him that there was not the slightest trace of quicksilver in his most carefully selected samples, and he finally abandoned his claim, concluding that it was worthless.

Next the claim was located by Don Thomas Alvarado, a Mexican rancher of the neighborhood, who believed that the beautiful blue, pink, and gray minerals of the vicinity, studded with crystals, some opaque and some transparent, must be a peculiar variety of marble. In the course of his endeavors to find out the value of the "marble," Alvarado sent many specimens to mineralogists in New York and other cities; and at last a German scientist, familiar with the lithia mines of Europe, happened to see some of these in the cabinet of an Eastern curio collector. He at once recognized them as lepidolite; and, obtaining samples for analysis, found that this ore from Pala Mountain was as rich in lithia as any known in the world. Development for lithia-bearing minerals followed, and resulted in the incidental discovery of large quantities of tourmaline and other gem materials.

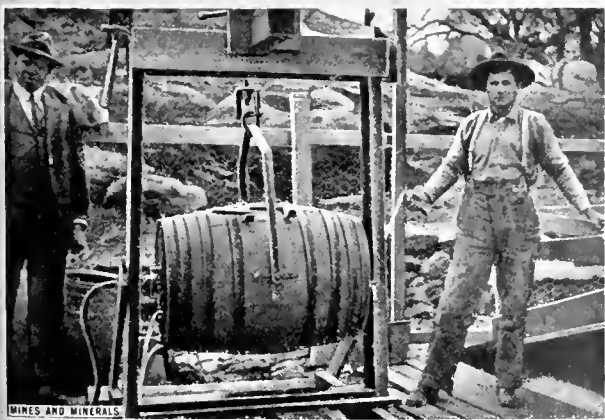

FIG. 1. WASHING GEMS AT TOURMALINE MINE

multiplied by two and a half in the short period of 2 years, indicate an encouraging growth. The success of a few really great mines of this character has proved that this branch of mining may easily be as profitable, in proportion to the capital invested, as the production of gold, silver, and copper. It has been found that American gems that cannot be marketed at home will sell readily abroad, England absorbing the entire American production of sapphire, and China taking large

Rather more romantic was the manner of the discovery of the Pala Chert mine, in the same mineral zone. Some time in 1903, Frank A. Salmonds, proprietor of the trading store on the Pala Indian reservation, was returning from a fruitless prospecting trip through the mountains, when his attention was attracted to one of the numberless ant hills, such as may be seen by tens of thousands anywhere in the arid Southwest.

It was a ray of ruby light reflected from the commonplace cone to the traveler's eye that caused him to pause for a second look. Investigation showed that the ray of light came from a small red crystal, which the prospector felt sure was not garnet (commonly found in the ant hills), and which he suspected might be tourmaline. Examining an outcropping ledge near by, he found other crystals, and proceeded to stake a claim, which was developed into one of the great gem mines of California, producing tourmaline, kunzite, and other stones.

Across the mountain range from Pala is a still more famous gem-producing district—Mesa Grande. The initial discovery of the ledge in which the Himalaya tourmaline mine was finally located antedates the recorded history of that region. Crystals have been found in Indian graves, dug before even the Spanish missionaries reached California; and both Mexican and American cowboys have picked up others in the vicinity ever since the

Himalaya tourmaline mine in 1898. It is conceded to be the world's greatest tourmaline mine, and its product, cut and polished in New York City, is now known all over Europe, America, and the Orient. It is particularly esteemed in China, where pink tourmaline (also known as rubellite) is held sacred to the gods. On the adjoining claim is located the San Diego Gem Mining Co.'s tourmaline property, which also has yielded a large quantity of fine gems.

While the world's most celebrated turquoise mines are those of Persia, on the slopes of Mount Ali Mirza, yet the mines of New Mexico, Nevada, and California, now supply the major part of this gem material used the world over. The turquoise mines of New Mexico are the most ancient mines of any description within the present limits of the United States, having been extensively worked long before the discovery of America by Europeans. It is said that in 1679 or 1680, 20 Indians at work in the mines near Los Cerillos (16 miles from Santa Fe) were killed by a cavé-in at the workings, and that the great Pueblo Indian revolt of 1680, which resulted in the expulsion of the Spaniards for 12 years, was due to this earliest of recorded American mine disasters. The reconquest of New Mexico was accomplished by De Vargas in 1692-94, but the Indians had carefully obliterated every trace of the turquoise mines. Not for 200 years were they rediscovered. They were found by John E. Coleman, better known to the mining fraternity of the Southwest as "Turquoise John." The production of the Los Cerillos mines is controlled by the Tiffany company of New York.

In 1898, Amos de Meules, of El Paso, Tex., discovered promising indications of turquoise in the Burro Mountains of N. Mex., and a very small amount of superficial prospecting brought to light some fine gems. A few days later the discoverer was shot and killed by a Mexican boy, and the claims have ever since been tied up in seemingly interminable litigation.

Of late years the production of turquoise has had to take second place in importance in statistics of

American gem production, being surpassed in value by the output of sapphire. In 1907, 230,000 carats of sapphire were mined in Montana. The annual production of this gem has been much smaller since then, being limited to avoid depreciating the value of the gem.

For years a little placer mining for gold has been carried on near the headwaters of the Judith River, and from time to time bright blue pebbles were picked from the riffles of the sluice boxes, where they had lodged. Not for a long time was it ascertained that these "pebbles" were real sapphires, equal in beauty and value to any that ever came from Ceylon or the Ural Mountains. Then followed a long, expensive, and discouraging search for the formation from which the gems had been carried by the water. It was found at last, on a fork of the Judith River, in Montana, fully 1,000 miles from the spot where the placer miners had first picked up the gems.

Probably no other kind of mining—perhaps no other occupation in which men engage—makes so strong an appeal to the imagination as diamond mining. From time to time diamonds have been picked up in every state of the Union, and gems of this kind have been sought for more persistently than any others.

In 1906, John M. Huddleston bought a tract of land in Pike County, Ark., $2\frac{1}{2}$ miles from Murfreesboro, and 120 miles from Little Rock. In places the soil presented a very peculiar



FIG. 3. DIAMOND WASHING PLANT IN ARKANSAS

American occupation. In more recent years, children of the Mesa Grande district school used to frequent the locality, particularly after heavy rains, in order to gather up the glittering baubles. Sometimes they sold a particularly fine specimen to the school teacher, and considered themselves lucky if he gave up a dime in exchange. Sometimes an enterprising youngster would collect enough to fill a tobacco pouch, and sell the lot to one of the tourists stopping at Rancho Cereza Loma, 5 miles away from where the bright stones were found.

Many of these "finds" were colorless and transparent quartz crystals, but others were 6-, 9-, or 12-sided crystals, varying in diameter from that of a slate pencil up to 2 inches or more, in many shades of pink, red, green, and other colors. Of course many persons wondered what the stuff was, and some believed that anything so beautiful ought to be worth money. On several occasions specimens were taken to San Diego and shown to jewelers there; but the jewelers proved no wiser than the people of the back country. Most of them seemed to think that anything so common that it could be picked up from the ground could not have any value worth considering.

However, specimens were finally sent to New York for determination, and it was not long until agents of New York jewelers were on the ground. The spot where the crystals were picked up finally passed into the hands of the Himalaya Mining Co., and active work was begun on the development of the

appearance, with greenish and bluish stains, leading Mr. Huddleston to suspect the presence of copper or lead. On the first day of August, while engaged in looking for indications of these, he picked up a small crystal. This he suspected might be a diamond, although he was not sure. That afternoon he started to ride in to Murfreesboro, when he noticed another crystal lying by the roadside. He dismounted and secured this also, and showed them both to jewelers in Murfreesboro, who assured him that they were real diamonds.

Huddleston and the members of his family thereafter put in their spare time looking for diamonds, but without success until late in September, when another stone was found.

Then the diamonds were taken to New York, and submitted to George F. Kunz for examination. He pronounced them to be unquestionably real diamonds, and recommended a thorough examination of the district in which they had been found. From that dates the beginning of diamond mining in Arkansas, but whether this will ever rank as an important diamond producing region remains to be seen. The stones are of fine quality, equal in every respects to the best stones of corresponding size found in South Africa. The formation, in a volcanic "pipe" of blue ground, or rather rock, (peridotite) is precisely similar to that in which the South African diamonds occur.

Up to the present time more than 1,500 diamonds have been found in the Arkansas diamond fields; and several diamond-mining companies have been organized. These are conducting experimental operations on a small scale; but whether diamonds will be found in sufficient quantities to justify the erection of extensive washing plants and the prosecution of diamond mining on a large scale, only the future can determine. However, the outlook is decidedly encouraging, and it is not improbable that diamond mining in Arkansas will soon dwarf all other American gem-mining industries in magnitude, importance, and value of the output.

來 來

A Remarkable Wire Rope

Usually the maximum loads lifted or hauled by wire ropes are amply provided for in the strength possessed by the ropes running under 2 inches in diameter. Occasionally in mining operations where heavily loaded cars must be hauled up steep inclines, stresses are brought upon wire ropes which can only be met by the use of very large sizes. Recently the John A. Roebling's Sons Co. made a haulage rope for the Spanish-American Iron Ore Co. which surpasses anything heretofore attempted in this line. The rope is 3 inches diameter, 7,810 feet long, and weighs 123,360 pounds. It has a breaking strength estimated at 377 tons. Heretofore, when very large diameter ropes have been required it has been considered necessary to increase the number of wires in the rope so as to keep the diameters of these wires within limits which would insure the rope taking bending stresses satisfactorily. Often the diameter of the drum has been a controlling factor, and even if very large ropes of the usual construction could have been obtained it would have been impracticable to use them because of the limited diameter of the drum on which they would have to be wound.

This remarkable rope is constructed of wires which a short time ago would have been regarded as impracticable for stranding into a rope to be bent around sheaves under heavy load. The plane upon which this rope is to be used forms a part of the Mayari railroad on the northeast coast of Cuba. It is 6,716 feet long and has a maximum grade of 25.13 per cent. The machinery has been built for hauling three loaded cars with a capacity of 112,000 pounds each up the incline at a speed of 15 miles per hour. The total weight of the loaded cars, added to the weight of the haulage rope, causes a maximum stress on the rope of about 140,000 pounds. The drums around which this rope

is wound are about 20 feet in diameter. When they were designed it was thought that if a rope of larger wires than those generally employed could be obtained, it would be practicable to wind such rope around the drums under heavy stresses, and an advantage would be derived from the superior resistances of such wires to abrasion.

The Spanish-American Iron Ore Co. therefore ordered a rope 3 inches thick of six strands of 19 wires each twisted around an independent wire rope center $1\frac{1}{8}$ inches thick. This center to consist of six strands of 19 wires each twisted around a hemp core. This construction, without precedent in rope making, called for wires for the outer strands ranging from .175 to .225 inch. To draw a wire nearly $\frac{1}{4}$ of an inch thick, possessed of the strength, toughness, and pliability of the finer sizes used for wire rope, calls for care and skill of the highest degree and imposes a task which but for recent improvements in the heat treatment of steel would be impossible of performance.

The manufacture of this wire was begun by producing a quality of steel which experience has shown is best adapted to the production of the highest grade of wire rope, from ingot to billet, from billet to rod, from rod to wire. The various processes of the manufacture were conducted until the proper number of coils of wire were ready for the stranding machine. These processes were subjected to the closest scrutiny and were accompanied by frequent and thorough tests such as bending, torsion, and direct tension. The results of these tests were satisfactory, and after the stranding was completed the manufacturers were confronted with the problem of loading the rope for shipment in such a way that it could be reloaded in a vessel in New York and conveniently handled on arrival at destination. To do this the length and weight of the rope had to be distributed over three reels loaded on two cars. This was accomplished by mounting an empty reel about 200 feet from the main reel on which the rope had been coiled when making, and revolving this reel until it had taken from the main reel a little more than one-half of the rope's length. The reel was then removed and another reel put in its place. The rope was looped around this reel so that when it revolved it took rope in equal lengths from both the main and the secondary reels. This was continued until one-third the rope was wound on each of the reels. The largest of these reels was 10 feet high by 9 $\frac{1}{2}$ feet wide. The other two were 8 $\frac{1}{2}$ feet high, one being 8 feet 10 inches and the other 7 feet 2 inches. The reels were then worked out of the shop on to a platform and put into cars alongside. The part of the rope between the reels was coiled on the bottom of the cars. The reels were lifted off the cars at the dock in New York and loaded on a steamer for Cuba, and unloaded at destination without mishap.

來 來

Systematic Tunnel Driving

An engineer who recently visited the Loetschberg Tunnel in the Alps, W. L. Saunders, quotes as follows: "When I arrived at the heading it was 9:30 A. M. The holes were being prepared for blasting. The blast took place at 9:35 A. M.; 5 minutes after the blast the men were in place removing the debris, and at a little after 11 A. M. the drill carriage was in place again and the rock drills were working. It usually takes from 25 to 30 minutes between the time at which the drilling is finished and the time at which the start is made to remove the debris; that is to say, 25 minutes for taking away the drill carriage, cleaning the holes, loading with explosives, and blasting. An additional 5 minutes are consumed in getting the smoke away by means of the ventilator, and then the men get to work at the debris. In order to assist the men a spray of water is discharged near the heading after the blast. This water is brought into the tunnel in a pipe placed within a larger pipe, which insulates it and keeps its temperature from being affected by the temperature of the tunnel."

Vanadium, Its Properties and Metallurgy

Different Ores and Where They Have Been Found. Method of Reducing. Uses of the Metal

By F. W. Brady, M. E.*

Vanadium is a striking example of a metal discovered 100 years before the commercial world was ready for it. There are notable examples of things that the world wants and for which millions of dollars are being expended in the search, and there are others already discovered but which are too costly as yet to be practical, but the condition will likely always exist of men being born, and of elements being discovered "before their time."

In the case of vanadium it was the demanded improvement in steel during the last few years that has given it a chance to make good, and it has already "beaten the field" in the "free for all contests" of alloys for increasing the tensile strength and the elastic limit of steel. Its use in cast iron for increasing the strength and wearing qualities, and in the non-ferrous metals, has given promise of its coming supremacy in all kinds of foundry productions. The reason that vanadium has taken the lead for increasing the strength of steel is that while it makes the much desired increment in tensile strength, it does not cause any brittleness, hardness or lack of elasticity. Carbon, manganese, nickel, and chromium have been used heretofore and occupied the attention of metallurgists for the purpose of strengthening steel, but the dose always left some dregs in the system of the patient.

From the achievement of vanadium today and the indications of what it may do in the future, it must not be inferred that it has been discovered in abundance and that it can be extracted from the ores without a struggle. Nor is the present price and the metallurgical process as now used in its preparation anyway near to our ideal expectations.

The first discovery of vanadium was probably made by Professor Del Rio, in Mexico, about 1800, but both its existence and any suggestions for its use were very hazy for many years. Strange to say, the investigations which gave vanadium its name were those made in connection with the analysis of iron made from the magnetic ores of Taberg, Sweden. The name, though, is after their goddess Vanadis. The investigator, Sefstrom, who named the metal, found it in the highest quality Swedish irons and steels as a natural condition, but it was a long time from then until American metallurgists began deliberately to put it into the molten metal. French chemists also did some investigating to determine the value of vanadium in steel; however, it was not until after 1900, when the advent of the perfected automobile and the airship forced a demand for structural metals of maximum strength and minimum weight, that the production and use of vanadium have been given serious consideration. Heretofore, even after some of its usefulness was recognized, it was looked upon as one of those rare and ultra-expensive speculative elements, for till within 10 or 15 years ago the cost was figured at over \$10,000 per pound, and no distinctly vanadium mines were known. It was found in minute percentages and in very widely scattered locations in combination with ores of copper, lead, silica, and in clays, sandstones, etc., in Spain, Sweden, France, Russia, Germany, Mexico, South America, and in many localities in the United States—Pennsylvania, Michigan, Colorado, Arizona, and others.

While there is a lively hunt going on for vanadium ores that will be profitable to mine, yet there are very few vanadium mines in actual operation. In the United States the leading one is probably that of the Primos Chemical Co., at New Meyer, Colo., which operates on a vanadium sandstone. The leading vanadium mine of the world is in Peru, located in the Andes

range some 16,000 feet above sea level. There are two kinds of ore from this mine, the black sulphide with carbonaceous material and from 40 to 60 per cent. of sulphur; this ore can be lighted with a match. It is called patronite after the discoverer. The second is a bright red ore, which is a clay impregnated with vanadium oxide. The roasted sulphide ore which carries about 19 per cent. vanadium is the ore handled. It is mined mostly in open cuts, sorted, roasted, and sacked. Transportation is on the backs of llamas from the mountains to the lake country. Then by boat across the lake to the railway terminal, and by rail to the coast. Sailing vessels carry it to the wharfs in New Jersey and then it is freighted to the American Vanadium Co., at Bridgeville, Pa. This company produces probably 75 per cent. or more of the vanadium supply. The ore is treated with sulphuric acid and transformed into vanadic acid. As to the characteristics of vanadium acid, it may be said that it is a dark, brownish powder that fuses into a brownish red or yellow mass, the latter color showing greater purity. When melted, it crystallizes into long brownish-purple needles.

The vanadic acid is fused with iron scale and aluminum, some iron shavings being added to give the required bulk to the charge. The crucible is a sheet-iron tank about the size of a barrel, that is lined with magnesite which is molded into place and dried for each charge. Each operation produces a button of ferrovanadium weighing about 75 pounds and carrying from 30 to 40 per cent. vanadium. The crucible operation is not carried on in the usual way by placing the entire charge before firing, but the method used is to start the action with a cartridge in the bottom of the crucible and then gradually add the charge up to the full capacity of the crucible. The ferrovanadium button is broken up and crushed, then sized with different mesh screens, each size of lump being most suitable for some particular service. The sizes range from that of one's fist down to a powder. Pure vanadium is a silvery-white metal. It can be melted only in the intense heat of the electric furnace. As a pure metal it is of no particular value. Its atomic weight is 51.27; specific gravity at 15° C., 5.5; and its specific heat is .1233 at 0° C. It is the alloys of vanadium that make the metal of such great commercial value. The most important of these alloys is the ferrovanadium, which is a hard, silvery-white alloy, produced by the chemical and aluminum-thermic process described above. This process gives an alloy carrying one-third vanadium and two-thirds iron that is free from carbon. It is especially important that the alloy be free of carbon because carbon destroys the beneficial action of vanadium and hence the necessity of the chemical process of manufacture. This alloy fuses at a much lower temperature than iron or steel, it is possible, therefore, with it to dissolve and distribute the vanadium through the molten metal.

When the open-hearth furnace is used for melting, the ferrovanadium is added directly to the molten charge and thoroughly stirred into it. With the cupola method of melting, the ferrovanadium is put into the ladle that receives the stream of melted metal and the mixing is done just before the pouring of the casting. With the crucible process of melting which is used in the manufacture of tool steels, the ferrovanadium and any other special alloys are all put into the crucible with the charge and a thorough mixture made before pouring the ingots. Vanadium was first used in tool steels because these being high priced would stand the extra expense of the new alloy. Gradually the price of vanadium alloys has been reduced until now they are available for use in the general run of steel castings, gray iron castings, and also in brass, bronze, babbitt, and aluminum.

In increasing the strength of cast iron from 10 to 25 per cent., depending upon the initial strength of the iron, and of steel to a much greater degree, one of the special attractions of the alloy for the manufacturers is the exceedingly small amounts of vanadium required. Less than two-tenths of 1 per cent. of vanadium is all that need be used for most work.

Vanadium has a strong affinity for nitrogen and oxygen,

* Scranton, Pa.

and its first uses were for coloring glass, pottery, dyeing, etc., and for making aniline black, indelible inks, and the like. Therefore, some of the vanadium added to iron, steel, brass, etc., takes up the gases in the metal and passes off in the slag. This is beneficial to the metal as it makes it more solid and of even grain. But vanadium is not intended primarily for a flux, because the fluxing can be done with other and cheaper substances. As much as possible of the vanadium charged should remain in the finished metal. The vanadium is expected to unite with the iron which it both toughens and strengthens, and not over 10 per cent. should be lost in the slag.

The explanation of the action of vanadium in cast iron and steel is not altogether clear. A great deal is known, however, on the structure of alloy steels under different conditions of heat treatment. The use of microphotographs in the investigations of the structure of steel has added greatly to our fund of knowledge in this line. These photographs are made of transverse sections of the steel that have been etched with acid and greatly magnified by the use of a microscope. Those who have made the investigations state that the steel is composed of pure iron, called *ferrite*, and a chemical compound of iron and carbon, called *pearlite*. It is claimed that the vanadium unites with and strengthens the ferrite, and that it toughens the pearlite. The vanadium in the steel seems to scatter the carbides and prevent their uneven bunching as is done in carbon steels.

To those engaged in the mining industries, the advent of the commercial use of vanadium means much. By its use the operator can get better car wheels, axles, springs, drills, and tools, ropes—in fact, its application is possible in most any structure where it is desirable to get greater strength and wearing qualities, either with or without any increase of weight. Brasses, bronzes, bearing metals, aluminum castings, etc., also come in the list of improved metals by the use of very small percentages of vanadium. It is important, of course, for the purchaser of vanadium steels, castings, and alloys, that he get the real thing. It might be possible to find "vanadium steels" on the market which do not contain vanadium.

Some of the vanadium products made for the use of foundrymen and steel makers are as follows: Ferrovanadium, in two grades, each carrying about 35 per cent. of vanadium. One grade has a much lower melting point than the other, owing to its containing from 10 to 16 per cent. silica, 6 to 10 per cent. manganese, and 2 to 5 per cent. aluminum. The higher melting alloy contains less than 2 per cent. each of silica and aluminum. The alloy with the lower melting point has a distinct advantage in its being more readily alloyed with iron and steel. However, where the silicon, manganese and aluminum are objectionable, the higher melting alloy can be used. The price of these alloys is based on the percentage of vanadium contained, being \$4 per pound for the vanadium. Hence, a 35-per-cent. alloy would cost \$1.40 per pound, the drop in price within the last 10 years being most remarkable. Cupro-vanadium, alumino-vanadium, and mangano-vanadium, are other alloys made for special applications in steel, cast iron, bronzes, etc., costing about \$1.50 per pound.

來 來

Manganese In Iron and Steel

Carbon may exist in iron mechanically mixed with it as graphite, or in chemical combination with iron, or in chemical combination with some third element contained in the iron, or in solution, if we admit that solution differs from combination.

Faraday, in 1822, first showed that steel when suddenly cooled dissolved completely in hydrochloric acid, but when previously annealed left a carbonaceous residue when thus dissolved.

Rinman, in 1865, observed that the quantity of carbon remaining undissolved when one and the same steel was attacked by cold hydrochloric acid differed greatly, being greatest in unworked steel and smallest in hardened steel, which sometimes yielded little or no carbonaceous residue. The carbon which dissolved he named hardening carbon, because chiefly found in hardened steel, and that which did not, cement carbon, because he found it chiefly in cement or blister steel.

Non-forgeable pig iron is saturated with carbon when the carbon content reaches 5 per cent., but in case manganese is present the carbon may go as high as 7 per cent. Gray pig iron with graphite may go from 3½ to 4 per cent., of which .3 to .5 per cent. is combined carbon. Wrought iron difficult to fuse can have a carbon content varying from .04 to 2.3 per cent. Wrought iron cannot be appreciably hardened. Steel capable of being hardened may have a carbon content of from .6 to 2.3 per cent. Manganese promotes the union of carbon in both molten and solid states. Highly manganeseiferous cast iron not only contains more carbon than other iron, but that carbon is ordinarily almost wholly in combination.

In annealed steel practically all the carbon is in the cement state, while in hardened steel the carbon is supposed to be in the hardening state. In tempered steel the immediate portion is in the cement state, and on the whole rather more in blue than in straw-tempered steel.

While manganese alloys with iron in all ratios, it is readily removed from iron by oxidation, and in this way it restrains the oxidation of the iron, while sometimes permitting the oxidation of other elements combined with it. Its presence increases the power of carbon to combine with iron at very high temperatures, say 1,400° C., and restrains its separation as graphite at lower ones. It prevents ebullition during solidification and the formation of blow holes, by reducing or removing oxide and silicate of iron, by bodily removing sulphur, by counteracting the effects of the sulphur which remain, as well as iron oxide, phosphorus, copper, silica, and silicates. While 1½ to 2½ per cent. manganese is universally admitted to cause brittleness, steel with 8 per cent. manganese is astonishingly ductile, with further increase of manganese the ductility again diminishes. Steel with 8 to 10 per cent. manganese, though extremely tough, is so hard as to be employed without quenching for cutting tools.

Oxide of manganese gives slags a strong characteristic green color and considerable fluidity. Manganese appears to volatilize with considerable rapidity at a white heat. A high percentage of manganese raises the melting point of iron, but small percentages may lower it. By increasing the solubility of gases and steel, manganese retains while solidifying the gas which it dissolves when molten, or by preventing the oxidation of carbon and the formation of characteristic oxides, manganese like silica probably less thoroughly hinders the formation of blow holes.

Manganese added to molten oxygenated iron removes its iron as oxide or silicate of manganese. Manganese appears to act upon oxygenated iron in two distinct ways, by reducing iron oxide, and by forming a readily separate double silicate of iron or manganese. It may act in both ways simultaneously. While iron oxide over in molten steel remains diffused or dissolved through the mass and renders it redshort, oxide of manganese if mixed with iron raises to the surface of the molten mass. Hence, as in the Bessemer and open-hearth processes of making steel the metal under ordinary conditions becomes slightly oxygenated. Manganese is usually added at the completion of these processes in the form of a manganeseiferous cast iron termed spiegeleisen or ferromanganese, and this reduces the iron oxide and is itself oxidized and scorified.

According to Osmund, manganese hinders the formation of cement carbon.

Chilian Mills and Amalgamation

A Description of the Early Form of Mill and of That Used at the Beresovsky Mine, Russia

By H. C. Baylton

The following is an abstract from Bulletin No. 75 of the Institution of Mining and Metallurgy and deals with the slow-running "Chilian," or "edge-runner" mill, universally used in Russia for crushing gold ores as a preliminary to amalgamation, etc., in place of "gravity stamps," the standard machine in other countries.

The types of high-speed roller mill (30 to 40 revolutions per minute) now being used extensively and successfully in other parts of the world for regrinding middlings and as an addition to stamp battery plants, are not comparable with the mill described herewith, since they are used for a different purpose.

Vein mining commenced in Kotchkar district about 1867, when the method of crushing consisted in spreading the ore on the main thoroughfares where carts and other vehicles could pass over it; when sufficiently pulverized it was gathered up and washed in sluice boxes.

This method was superseded by preparing on hard ground a circular track, on which the ore was spread, and over which carts filled with stone, to make weight, passed until the ore was reduced to the requisite fineness for washing.

In 1868 other crushing appliances were tried, such as a cast-iron weight attached to the end of a pivoted rocking rod, and later gravity stampers, making from four to six blows per minute, operated by horses. The stampers, usually five in a battery, consisted of hardwood stems shod with cast iron, falling on an enclosed anvil mounted on a wooden foundation. The duty of this primitive gravity mill was from 2 to 3 tons per day dry crushing.

In 1870 edge-runners of rude construction were introduced consisting of a pair of stone runners about 7 feet in diameter

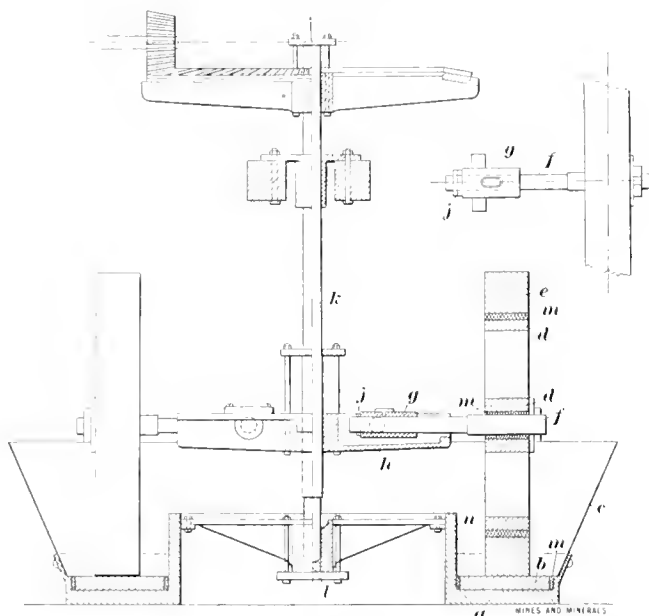

FIG. 1

by 18 inches in width, mounted on a horizontal wooden axle and revolving on an enclosed grinding track made of flat slabs of stone. These mills were operated by horses, much in the same way as a horse whim. The output per day, dry crushing, was from 2 to 3 tons, the runners making from 3 to 4 revolutions per minute.

Between 1871 and 1873 mills made with pans, grinding track, and runners of cast iron were introduced, these also being operated by horses; but, at about this time, a mill driven by steampower made its appearance and wet crushing with mercury was adopted.

It was not, however, until between 1880 and 1885 that steam-driven mills came into general use in Kotchkar, and

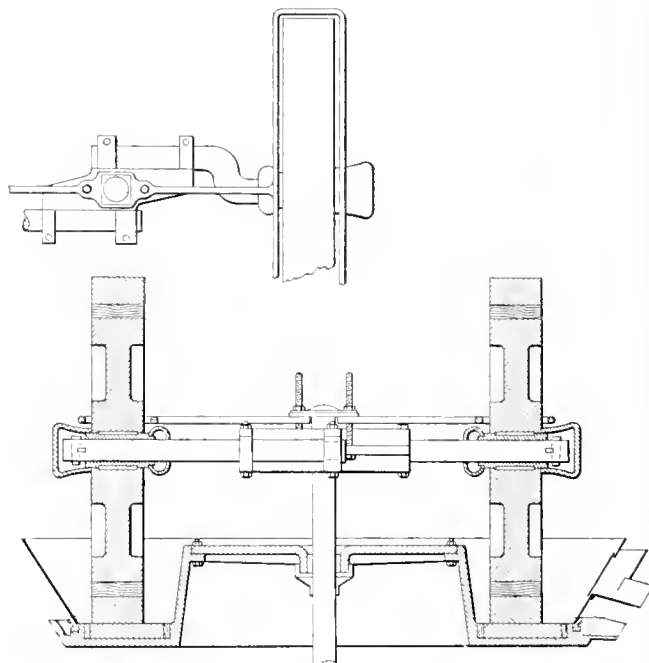

FIG. 2

important improvements took place in the design and capacity of the mill.

The design at this period was similar to that of the standard mill, Fig. 1, commonly used at the present time, with the difference that the earlier type had runners revolving on fixed axles, whereas the majority now in use have fixed rollers on revolving axles.

The mill consists of a circular cast-iron pan *a* from 7 feet to 10½ feet in diameter (usually made in two pieces in the case of the larger sizes and in one piece in that of the smaller), to which are bolted wrought-iron sides *c* protected at the bottom by wearing plates. The cone *n* inside the pan is also protected from wear by wrought-iron liners.

The track *b* on which the runners travel is formed by from six to eight annular sections or dies, 3 inches to 3½ inches in thickness, held in place by wooden wedges.

The runner consists of a cast-steel tire or wearing ring *e*, 5½ feet to 6½ feet in diameter by from 7 inches to 12 inches in width, and from 9 inches to 10 inches in thickness, fastened by wooden wedges *m* to a central casting *d*, which forms the boss of the runner.

The boss is provided with an annular recess for the reception of compensating weights when the outer ring becomes worn.

The runner is keyed on a wrought-iron axle *f* revolving in a cast-iron sleeve *g*, provided at the inner end with a collar bearing *j* to take up pressure due to centrifugal force.

This sleeve has two trunnions which fit in bearings recessed in the cast-iron center crosspiece *h*, and is free to move up or down vertically, allowing the runner to accommodate itself to variations in the height of ore feed.

The center crosspiece, transmitting motion from the vertical driving shaft *k* to the runners, fits on a square section of that shaft, and is capable of vertical adjustment to compensate for the wear of tires and dies.

This type of mill is notable for its simplicity, requiring little

close or skilled attention, being in this respect comparable to a rock breaker of the jaw type.

It is of interest to note that the Beresovsky mill (considered until recently the most up-to-date Chilian milling plant in Russia), has rollers revolving on a crank-axle, see Fig. 2. In this instance the axle is free to move up and down, thus allowing the roller always to stand in a vertical position.

The objections to this mill are, that the speed must be kept low; and that the ore fed to mill must be broken so small as to pass a 1-inch ring.

The speed is 11 revolutions per minute, the mean radius to center of runner being 3 feet 9 inches, which gives a mean roller travel of about 260 feet per minute.

If this be increased, lateral play of the roller results from rapid wear of the brass bushing by the outside axle collar; in fact, a roller has been known to break away as a result of such play and go through the side of the mill, and a guard is now provided with the object of preventing this. The shock to the bushing when the mill is fed with coarse broken ore frequently causes a breakage of that part.

With this design of the mill, an increase of capacity may be obtained by increasing the weight of the runner, or increasing the number of runners from two to three.

A limit is soon reached beyond which there is no increase in efficiency as a result of increasing weight.

Three runners have been adopted in some of the mills in this plant, but owing to the speed limit their capacity is low.

The weight of each runner is 10,800 pounds, and the capacity with two runners is about 24 tons per working day of 24 hours.

In gathering data of some typical mills crushing ore very similar in hardness and general character, it was impossible to obtain accurate figures as to power required per mill, but it is estimated at between 7 and 12 horsepower.

The tailing is very fine, and of uniform, even grade, a small percentage remaining on the 30- and 60-mesh screens. The capacity of the mills is low, owing to the fact that they are all designed and run to avoid violent agitation of the pulp within the pan.

The mean travel of the runners seldom exceeds 300 feet per minute, the depth of the water above the ore is comparatively high, and the width of the pan is the minimum practicable, with the result that the motion of the pulp within the mill resembles that of water flowing in a launder.

The main objects in view are to crush the ore very fine, and to obtain the highest possible percentage of the gold by amalgamation and from the pan itself.

That the mills successfully fulfil these requirements is evident from the screening analyses and amalgam percentages obtained, but the economy of using such a type of mill in any but quite small plants is doubtful. Most of the mills are hand fed with ore broken to any size up to a 4-inch ring.

An automatic feeder similar to a "Challenge" is in use at the Beresovsky mill, which is understood to give satisfaction, although the reported objection to this type is that with wet, sticky ore it is unsatisfactory, which probably accounts for its very limited adoption in the mills throughout the country.

The foregoing remarks make it evident that the low capacity of the mills is due to the purpose for which they are primarily used; i. e., amalgamation. So long as this factor remains the guiding principle in the average milling practice of the country, but small advance in the development of the mill for maximum capacity may be anticipated.

With the above object in view, the mill capacity has been increased either by increasing the diameter of mills and the weight of the runners, or by increasing the number of runners from two to three. The latter, under these conditions, would appear to be the better of the alternatives, but this type of mill has not become popular.

The diameters of the mills have been gradually increased

from 7 feet to 8 feet 2 inches, 9 feet 4 inches, and 10 feet 6 inches, with runners weighing from 3,600 pounds to 10,800 pounds each, but the increase in capacity with mills of large diameter is not commensurate with the extra floor space occupied; in fact, this type of mill compares most unfavorably with stamps on an output basis, in respect to power, space occupied, and first cost.

A comparison of two mills shows that, while the mean travel of the runners per minute in one is only 31.4 per cent. greater than in another mill, the capacity is 62.5 per cent. greater with 1-foot 3-inch diameter larger runner.

An investigation of the cause of the higher capacity led to the conclusion that this was due to the more violent agitation of the pulp in the pan, with the result that the discharged product was coarser, the percentage of +100 mesh being 37.3 per cent., while in the smaller mills it was only 17.33 per cent.

It was on the strength of these results that a Chilian mill was designed which embodied improvements suggested by experience with this type of mill.

The average weights of tires and dies worn out and discarded, taken from a number of mills, are: Tires, from 10 per cent. to 15 per cent. of the original weight; dies, from 36 per cent. to 45 per cent. of the original weight. The total cost per ton for tires and dies was 6.52 cents, or 1.192 pounds of iron.

Inside plate amalgamation is the standard practice in Russia. Clean-ups are made once in 24 hours, and mercury varying in quantity from 6 pounds to 8 pounds is added to each mill at intervals during the day, from 2 pounds to 3 pounds of this being introduced an hour before the clean-up, just previous to "running down" or ceasing to feed, in order to collect the amalgam.

The copper plates used are 4 feet 8 inches in length by 2 feet 4 inches in width, there being generally two or three to each mill, with rather deep and wide riffles or traps before and after each plate.

The plates are run hard and kept under locked covers until the clean-up, which is the only time they are touched during the 24 hours.

The slope of the plates varies in different mills, but is generally excessive and the water out of all proportion to the amount required to keep a free surface.

The clean-up takes place in the following manner: The men cease feeding an hour previous, and the ore already in the mill is run down as low as possible. The screens are then removed, water feed turned on full, and the pulp and amalgam on the plates swept with brooms. The riffles or traps catch the amalgam and heavy particles of iron during the "brushing out," and, in order to keep the riffles from becoming filled with sand, a man walks from one to another and agitates their contents by means of a T-shaped stick.

Any mercury and amalgam remaining in the mills after the preliminary brush out is finally removed by pouring water from a height out of buckets into the recesses while a man is violently brushing.

After the mills are cleaned up, the contents of each riffle are agitated by hand (the pulp passing over the plates into settling boxes, to be returned to the mill later) until only a few particles of iron, sand, and amalgam remain. The plates are then scraped down by means of "rubbers" to remove the excess of mercury splashed on them, and the contents of the riffle are discharged through side doors into dishes.

The amalgam is now cleaned, that from each mill being kept separate and retorted daily.

Mercury losses by this system of clean-up are somewhat high, owing to excessive handling and multiplication of volatilization losses from the daily retorting of small quantities of amalgam.

At the end of each month (sometimes after longer periods), the plates are removed and placed in a box through which live steam passes for from 1½ to 2 hours, the plates being then placed on a table and the amalgam scraped off by means of chisels;

mercury is afterwards added and rubbed in (this being considered superfluous in some plants), and the plates replaced.

This is really the only dressing the plates receive in the month. Modern amalgamation methods are imperfectly understood, but with the class of shiftnan left in charge opportunity for stealing has to be reduced to a minimum; and to run soft plates, requiring dressing at regular intervals, would be out of the question.

In the Beresovsky mill the wash-up is greatly expedited by having the sides of the pan movable. At clean-up the whole of the side is raised by a lever arrangement, and the contents of the pan are flushed into an annular gutter which forms part of the lower casting.

來 來

Trade Notices

Centrifugal Pumps.—An improved line of centrifugal pumps has just been placed on the market by the Goulds Mfg. Co., of Seneca Falls, N. Y. These pumps are constructed in both single-stage single suction, and single-stage double suction types. Either type can be arranged for belt drive or direct connection to electric motor, gas, gasoline, or steam engine, or steam or hydraulic turbines. The single-suction, as well as the double-suction, pumps contain many special features of great importance from an operating and economical standpoint. In details of construction every point bearing on efficiency, durability, and convenience has been carefully considered, with the result that the Goulds Mfg. Co. claim great superiority for these machines. Mine managers interested in this class of pumps, and most progressive managers now are, will be cheerfully sent full details and what they are guaranteed to accomplish on request made to manufacturers.

Steel Derricks and Drilling Rigs is the title of a book of 54 pages, issued by the Carnegie Steel Co., describing the construction of drilling derricks of steel, and giving facts regarding their successful use. The book contains a large number of drawings showing details of construction and photographs of rigs and should be of value to all interested in deep drilling. It can be had upon application to the company.

The Relation of Size of Fan to Output.—In an engineering paper, mention was recently made of a fan 32 feet high handling 20,000,000 cubic feet per hour as being one of the largest fans ever built. It is stated by the American Blower Co. that at Clydach Vale pit of the Cambrian Collieries, Ltd., Glamorgan-shire, South Wales, is a Sirocco fan only 13 feet 5 inches in diameter which delivered on test 36,000,000 cubic feet per hour—nearly double the capacity of the 32-foot fan mentioned, and less than half the size.

The Chicago Pneumatic Tool Co. announces a change in the trade designation of the air compressors manufactured by them, which heretofore have been known as the Franklin compressors, their compressor works being located at Franklin, Pa. Because of the fact that its pneumatic tools, electric drills, rock drills, and other articles of manufacture are invariably identified with the name of the company, it has been determined to hereafter use the trade name "Chicago Pneumatic" as applying also to their air-compressor product.

Johns-Manville Building.—A 12-story office building is being erected on the southeast corner of Forty-First Street and Madison Avenue, New York City, for the H. W. Johns-Manville Co., who will occupy it about May 1, 1912, as the general offices and New York salesrooms of the concern.

The building, which has been designed so that all four sides will be attractive, will be known as the "Johns-Manville Building," and will be one of the few 12-story structures entirely occupied by a manufacturing concern for office purposes only.

It will be of fireproof steel construction throughout, and will contain two Otis passenger elevators of the latest type. Each floor will have an area of 2,500 square feet, or a total area

for the 12 floors and basement—which will extend under the sidewalks—of 34,500 square feet.

An unusual feature connected with this building will be the fact that the tenant manufactures and will furnish a considerable part of the equipment of the structure. Among the various materials which the H. W. Johns-Manville Co. will install will be asbestos roofing, asbestos plaster, linolite system of lighting, conduit for wiring, flushometers, sanitor seats, electrical accessories, waterproofing, Keystone hair insulator, asbestos wood, fire extinguishers, asbesto-sponge felted, and J-M Asbestocel pipe coverings, etc.

The name of "H. W. Johns-Manville Co." and "Asbestos and Magnesia" have so long been synonymous, that many will be surprised to learn that this company also manufactures a large line of electrical goods, plumbers' supplies, building materials, automobile supplies, cold-storage insulation materials, railroad supplies, etc.

Moisture-Proof Dry Battery for Use in Mines.—In mines where considerable moisture is prevalent it sometimes happens that the cardboard cartons of dry cells absorb so much moisture that when the cells are placed side by side, or on a metallic base, they become short-circuited. This causes them to run down and deteriorate quickly, thus necessitating frequent renewals and an attendant maintenance expense. The Western Electric Co., realizing this, has recently placed on the market a new, moisture-proof dry battery. This cell has been designed especially for use in mine, railway, and general telephone service where the batteries are subjected to moisture. The new cell has the same high efficiency, long life, high voltage, and great recuperative power as the standard "Blue Bell" battery, but the cardboard carton has been treated with a special impregnating compound which prevents moisture from reaching the cell proper. This will give sufficient protection so that the life of the batteries used in damp places will be as great as that of the batteries used in any other magneto service under ordinary conditions. The Western Electric Co. is employing 26,000 persons as compared with 29,000 in 1906, which was the largest number ever on the company's books at any one time. On January 1, 1909, there were less than 18,000 persons employed, which number was increased to 23,600, approximately, at the beginning of 1911.

The Goodman Mfg. Co., of Chicago, have recently arranged, through their Pittsburg office, with Mr. James R. Cameron to represent their line of electrical coal-mining machines and locomotives in northern West Virginia, with headquarters at Fairmount, W. Va. Mr. Cameron is thoroughly versed in the application of electrical machinery for coal-mining purposes, and this, with his wide acquaintance, will enable him to be of assistance to the operators in this section.

Mine Scales.—As the service demanded of mine scales is particularly severe, it is essential that they be as simple and strong in construction as is possible with the maintenance of accuracy. In addition, the varying conditions at mines require varying designs of scales. The Winslow Government Standard Scale Works, of Terre Haute, Ind., recognize the above facts. They manufacture 250 types of scales, ranging in capacity from 1 ton to 250 tons, and they have the men and facilities to solve any mine-scale problem. Every scale manufactured by them is guaranteed. Their catalog is sent free on request, and as it contains valuable scale information it is well worth having.

The Sullivan Machinery Co. announces that Mr. A. de Gennes, for a number of years general representative of the company at Paris, France, has retired from business. His successor, Mr. Hart O. Berg, whose address is 30 Rue Des Champs Elysees, Paris, will be in charge of the business in France under general direction of the European branch office at London, 814 Salisbury House, Mr. H. T. Walsh, manager. Sullivan diamond drills, rock drills, hammer drills, air compressors and their parts, will be carried in stock at Paris as heretofore.

Tin Deposits of El Paso County, Tex.

Geology and Location of the Deposits. Smelting Tin Ore with an Oil Furnace

By Regis Chauvenet*

Tin deposits are exceedingly rare in the United States.

During the South Dakota tin excitement some 30 years ago, several companies were formed, the largest of which is said to have absorbed \$5,000,000. That there is tin in the region is certain; that no commercial quantities have yet been produced is equally so. Owing to a vast amount of fraud in the original placements, there are today many who believe that there is not a word of truth in any reports of the metal in that state. It has come to my personal knowledge that in the vicinity of Tinton, S. Dak., cassiterite has been found, and it is reported that the prospect improves with depth. Probably nothing has been developed averaging over half of 1 per cent. A small quantity of metallic tin was reported in the year 1906.

A small tin deposit has been known for many years in the "Temescal" district, San Bernardino County, Cal. Like most tin deposits this is in a granitic formation, and is disseminated in small fissures accompanied by tourmaline. By great expenditure of time and effort, enough of this ore was secured to make a small trial run, producing, it is said, about 200 pounds of the metal. This was many years ago, and it seems very unlikely that any further effort will be made to work the veins.

In North and South Carolina are small deposits of cassiterite, from which concentrate has been made for a number of years, and shipped abroad for conversion to metal. The tin in this concentrate is low, not because of defective work, but because of a replacement in the very body of the cassiterite by iron oxide.

In the 70's of the last century, Missouri had her tin excitement. The secretary of the "Missouri Tin Mining Co." called upon our firm to remonstrate because we declared they had no tin. The details of this conversation have passed from my mind, except one gem, characteristic of the metallurgy of the period. "The tin is there, and we know it," said the official, with some heat, "but we know as well as you do that it isn't in a condition susceptible of chemical detection."

Having often been called upon to examine so-called tin deposits with negative results, I had little expectation of seeing anything worth while, when sent to Texas in 1908 to report on a supposed tin prospect.

It was at the instance of my brother, S. H. Chauvenet, of Pennsylvania, that I made the first examination. He is now president of the El Paso Tin Mining and Smelting Co., which was formed to exploit the ground.

The property was mentioned in the United States Geological Survey bulletin by Weed several years ago, and the "El Paso Folio" gives it some description. One of the "blocks" into which the region is divided by the Survey has in fact been named "Cassiterite."

The deposit is about 12 miles, almost due north, from the

city of El Paso, Tex. The range of mountains whose southern terminus is at El Paso, is known by several local names at various latitudes. Its proper geographical name would seem to be the San Andreas, but south of Las Cruces, N. Mex., it is called the "Organ" range, and this name changes again as the range crosses into the western arm of Texas, to "Franklin Mountains." The broad and low pass known as "St. Anthony's," just north of the boundary between New Mexico and Texas, marks the division of names.

The tin deposit is in the Franklin range, and on its east flank. On the west of the range flows the Rio Grande. On its east side stretches a great plain, or, as it is called in the Survey Folio, "Bolson." The range stops abruptly close to El Paso.

The geology of Franklin Mountain is treated at length in the "El Paso Folio," to which I would refer any who may wish to go into the matter in detail. The base of the range is granitic, the granite being surmounted by pre-Cambrian and Cambrian quartzites, and these again by Ordovician and Silurian limestones. This description applies to the east flank, and especially to that portion of it in which the tin is found. The tin is confined wholly to the granite, so far conforming to the general rule of its occurrence.

The sedimentary formations are broken by a great fault, of which they form part of the foot-wall. Thus the east flank of Franklin Mountain presents a bold escarpment with the Silurian limestone at the top and the granite at the base. It is stated in the "Folio" that on the west flank of the mountain, which is mainly a "dip slope," limestones of more recent age are found unconformably placed on the Silurian.

The "Bolson," which stretches far to the east, seems to be composed entirely of detrital material, and like most such plains is destitute of surface water. Its underflow, however, is considerable, and the city of El Paso gets most of its water by driving wells several hundred feet down in

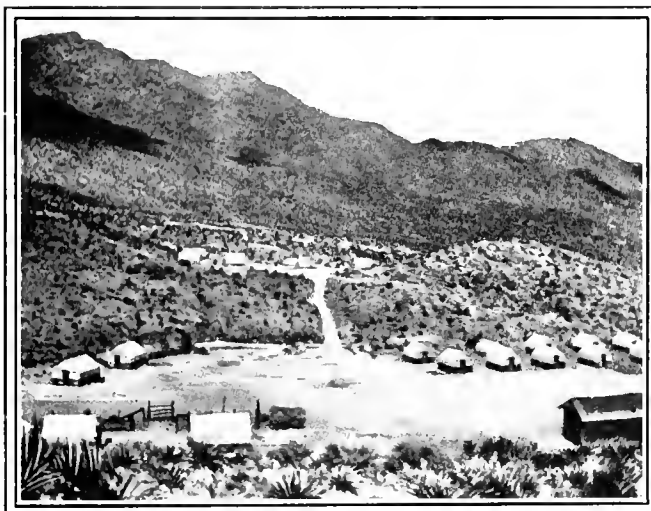

EL PASO TIN MINING CAMP

the "Bolson" a few miles north of town.

From this plain rises, to the west, first a "humpy" set of foot-hills, very largely composed of transported material, then a granite exposure at the base of the steep broken-off sedimentary series. The area of this exposure in which the tin is found is about 4,000 feet N—S, by an irregular width E—W, perhaps an average of a quarter of a mile.

Dikes run roughly east and west through the granite, though they are sometimes little more than an inch thick. They are often filled with a pegmatitic mass, that has become silicified, especially at contact with the country rock. With the silica cassiterite is found very commonly.

The main source of tin ore, however, is not in these "dikes" proper, but in the country rock close by. The dikes are rarely over 2 feet wide, but the "disseminated" ore occurs in lenses several feet wide and many feet in length, forming the more important basis for mining operations.

Locally called "cassi-granite" this ore might be better named "cassi-feldspar," for the granite shows very little quartz. Most of the ore might be correctly described as cassiterite disseminated in feldspar, the latter usually of a clear pink tint. However, this feature is not universal, some of the gangue showing feldspar and quartz mingled in true granitic fashion, and with cassiterite interspersed. Mica is wholly absent in

* Mining Engineer, Denver, Colo.

the tin-bearing portion. The discovery was made on "float" mineral of this "disseminated" kind, and until recently many thousand pieces could be picked up on the hillside.

Six of these "dikes" have been traced. They differ greatly in mineralization, also in the quantity of impregnated country rock to be found in their vicinity.

In one of the gulches on the hillside close to one of the dikes, some stream tin has been found. It is not abundant, though some of the ground has been moved and the material put through jigs in the mill. Occasionally "chunks" of pure cassiterite turn up; one found weighs about a pound.

Notwithstanding the fact that the "dikes" are not the chief source of ore, their utility, as indicating the proximity of disseminated ore, is obvious. At the most productive or No. 4 dike, the lenses are found exclusively on the south side of the dike, a phenomenon as yet unexplained, as exploration has not proceeded far enough to warrant assertions as to any law of deposition.

Naturally material that is supposed to carry enough to pay, is sent to the concentrating mill, however, not enough steady work has been done to determine an average mill run. It is estimated that ore under 1 per cent. can be mined and treated, although the average so far was much higher than that; but I am not prepared to say how much higher.

The disseminated ore is nearly black, rarely crystallized to the naked eye, is extraordinarily free from all other metals, and separates easily from its feldspar gangue. Thus, as a concentrating proposition it has: Great difference in specific gravity between ore and gangue; i. e., say 6.9 and 2.6; unusually easy separation of ore from gangue in crushing; and great purity of the product.

Nature has conferred so many helpful concentrating features on the ore it would be a very poor appliance that couldn't recover product high in total saving and in assay. The tables used are the Sutton-Steele-Steele dry tables. After their adoption water was developed on the property, though not in great quantity, and jigs have been installed. The system of concentration is still under adjustment, but hitherto the concentrate carried from 56 to 71 per cent. tin, and it is expected that it will never be much under 70 per cent. tin. That means hardly more than 10 per cent. gangue, and smelting so rich a product is quite easy.

The work done has been largely in the nature of prospecting. The latest developments are said to be the best yet shown, though as the greatest depth attained is still under 100 feet, little can be said as to the size of the ore bodies.

Walter E. Koch has had charge of the furnace work, and some of the results are worth detailing.

The furnace is small with a reverberatory hearth $5\frac{1}{2}$ ft. \times $3\frac{3}{4}$ ft., heated entirely by an oil flame. So far as I am aware no tin was ever produced before by such an appliance. The oil is dropped in the burner by gravity from a barrel placed about 50 feet from the furnace. A blast of air pumped by a small gasoline engine, carries the oil in through an annular space which surrounds the little oil pipe.

The flame is controlled by keeping the air blast constant and adjusting the oil valve, as a greater or less heat or reducing action is required. Not one of those interested had ever seen or heard of such a furnace for tin reduction, but as a similar appliance was in successful use in the East for heating billets, and as it evidently gave plenty of heat and a fine reducing

atmosphere, it was adopted. A German firm working at Hanover and Hamburg wrote to ask the company to adopt their tin furnace, which they are working on Bolivian ores. Upon learning that we had adopted the oil burner, they wrote again, demonstrating the impossibility, indeed the absolute folly of such an attempt, offering to install their furnace for 2,000 marks. The oil furnace, by the way, cost about \$2,000. However, when this message of gloom reached us, we had already shipped our first ton of tin, with a recovery of 92 per cent.

The little furnace which was erected as an experiment, will probably be retained as a part of the plant. It has four openings, which may conventionally be called N, S, E, and W. At the north end the oil and blast enter. Opposite on the S end, is a door through which the charge is rabbled. The charging door is to the west, the tap hole to the east. The hearth is slightly "dished," the lowest point being at the tap hole. The latter is plugged with a ball of damp clay during the running. The charging door is just large enough to enable the workman to throw a shovel full of ore to any part of the hearth, though the charge is better spread from the rabbling door.

Anthracite culm is used for the reducing agent.

The concentrate, mixed with the proper percentage of coal, is charged, about 200 pounds at a time, on to the preheated hearth. After each addition the flame is allowed to play over it for 20 or 30 minutes, before another charging is made. When about 800 pounds of concentrate has been introduced, the heat is maintained steadily, at about 2,000° F., but is raised to a higher temperature toward the close.

An electric pyrometer informs the workman of the temperature. It is necessary to "rabble" the ore on the hearth from time to time, to enable the very fluid metal to collect at the tap. The latter is opened at intervals by punching an iron bar through the clay plug that closes the hole.

The metal is of extraordinary purity. A remelting kettle was provided, as it was expected that "tossing" or "poling" would be necessary, but this method of refining is not needed. The metal runs from the hearth 99.80 fine; even the trivial impurity which is iron, is hardly an impurity when in such minute amount.

About 8 tons of tin have been shipped to date. It has averaged 3 cents per pound above the New York quotation, owing to its purity. In fact it not only classes as "grain tin," but is a very fancy brand at that. Tin is quoted today at 38 cents per pound, a very high figure.

The company was organized on a prospecting basis, but is already on the list of producers.

來 來

Copper ores are widely distributed throughout Nova Scotia. In a recent United States Consular Report it is stated that two belts of copper ore traverse the northern part of the peninsula and another crosses the southern part of Antigonishe County. In northern Cape Breton promising outcrops occur at Cheticamp and probably there is not a county in the province that cannot boast of a copper prospect. Yet of all these, probably but two, namely, Copper or Polson Lake, in Antigonishe County, and Coxheath, near Sydney, have been developed to any considerable extent. From these mines some thousands of tons of good ore have been taken out, carrying from 3 to 10 per cent. copper.



OIL FURNACE AT EL PASO TIN MINE

Empire Mine and Mill, Grass Valley, Cal.

A Description of the Methods of Mining and Raising the Ore, and the Milling and Cyanide Practice

By Al. H. Martin

The properties of the Empire Mines Co. are about a mile from the city of Grass Valley, the center of the leading quartz gold district in California. The Empire Mines Co. has an extensive acreage, and enjoys the unique distinction of having operated its property more continuously since its discovery than any other company in the district. The properties comprising the present Empire mine were mostly located in 1850, the veins occurring in diabase. The richness of the ore immediately attracted attention and the mine soon became the most important gold producer in the district. From the date of its location to the present time, it is estimated that the Empire has produced from \$10,000,000 to \$12,000,000, with the annual output averaging around \$900,000 per year at this time. The property, after the North Star mine, is the leading producer in the district, with the veins proven to a depth of approximately 200 feet below the 3,500-foot level, the deepest working laterally.

The vein shows much of its original quality and value so far as it has been followed, and indications seem good for its continuation indefinitely.

There are two ore bodies, known as the Rich Hill and Ophir Hill veins. These exist as one ledge in the Magenta claim, but branch out as two distinct veins when approaching the Empire property. In the lower levels the veins gradually approach until again they merge into one compact ledge. Near the eleventh level the veins cut across the diabase into granodiorite, but at the 1,600-foot point again strike into the diabase. The walls are sharply defined, with the space between these and the vein occupied by altered country rock. At several points faulting has appeared but the slips have never been of a serious nature and the vein has been easily recovered. The vein varies from 10 to 18 inches in width, and carries about \$30 in gold per ton. Occasionally ore of remarkable richness is found, in fact some of the richest ore in the district has been taken from the property. At times these "pockets" have yielded from \$10,000 to \$50,000 in gold. The ore is free milling, with a small percentage of sulphides.

From the three-compartment shaft, levels are run at approximately every 100 feet and raises driven through to the level above, or within about 15 feet. At intervals, varying from 50 to 100 feet, auxiliary levels are driven on the vein. The raises are sent up from the center of the ore body, and by the mining method employed the vein is blocked out in such a manner that stoping can be carried on simultaneously in the different drifts. In some instances the driving of intermediate levels is avoided and stoping carried on at only one face. In either event the ore is easily handled from the various levels. At a convenient point above the last intermediate level is located the "go devil." This consists of a brake wheel and two drums, the friction regulated by the employment of a post

brake. By means of this mechanism the cars in the stopes are raised and lowered. Double track is laid down the raise, with turn sheets placed at the points where drifts and raises are encountered. As the ore is broken in the stopes it is loaded into the cars and sent by gravity to chutes in the main level, where they dump automatically. As the stope is advanced the "go devil" is moved up further. When it is desired to keep the mechanism stationary, cables are strung over pulleys located above the turn sheet. In the latter case care is always taken to either place the drums to one side of the track, or else at a sufficient height to permit the cars to pass under.

The cars on the main levels are hauled by mules, after being filled by gravity from the chutes. Owing to the flatness of the vein this special method of mining has been employed, as conditions in the Grass Valley district from a mining standpoint more nearly resemble those on the Rand in South Africa than the usual American ore bodies. The employment of the "go devil" or gravity plane and the method employed for stoping the ore has largely cut down expenses prevailing prior to the inception of these innovations.

Piston machine drills are employed for making holes for blasting. The level cars are discharged into bins in the shaft, which in turn feed the hoisting skips. The latter discharge automatically into bins upon reaching the surface. From the surface bins the ore passes through a gyratory crusher, which reduces it to a maximum size of 2 inches and drops it into bins beneath, from which it is loaded into cars and trammed to the mill bins. Automatic feeders deliver the ore to the forty 1,000-pound stamps, which drop 102 times per minute and crush through a No. 7 slotted screen. The stamps are arranged in eight batteries and have a

total capacity of 90 tons per 24 hours. The pulp passes from the stamps to eight plain copper amalgamating plates 17 feet long by 4 feet 4 inches wide. Inside and outside amalgamation is employed, the outside plates being cleaned every 24 hours, and the inner ones twice monthly. From the plates the material passes to two Frue vanners, where the concentrate is collected. This is sold to smelters, the company making no provision for the treatment of concentrate on the ground.

The tailing is delivered to a Gates tube mill for regrinding and the product passes to the cyanide plant by way of a terracotta tile launder 425 feet long. The cyanide plant has a capacity of 150 tons per 24 hours, and everything has been arranged to facilitate the handling of material by gravity. The launder delivers to two settling cones and five sizing cones. The settlers have diameters of 8 feet 4 inches, with the sides having an incline of 50 degrees. The sizing cones are 4 feet 8 inches in diameter with the sides given a 70-degree slope. The sizing cones are fitted with hydraulic sizers and the product separated into sand and slime. The slime passes to four clarifying tanks by way of a galvanized-iron launder and sump. The tanks are 24 feet in diameter, 22 feet deep, and provided with false conical bottoms. The thickened slime passes through a 1½-inch pipe, discharging 9 feet above the bottom of the tank, into a launder commanding the four agitating tanks. Each of the latter is 10 feet in diameter by 18 feet deep. Compressed



HEADGEAR, EMPIRE MINE

air is admitted at a pressure of 10 pounds per square inch by way of a central cylinder nozzle. The piping extends throughout the tanks, insuring a continuous treatment of the slime under all conditions.

From the agitating tanks the slime flows to two vacuum filters, each having a capacity of 70 tons. A special pump was designed for the filter department and is proving highly satisfactory. This pump makes a 24-inch vacuum with 90 revolutions per minute and elevates the effluent to a 16'×20' storage tank, a distance of 41 feet. The slime cake is removed from the fillers by compressed air, instead of by the usual jet of water. The compressed air is delivered by an Ingersoll-Rand compressor which also furnishes the air for the agitation of the slime and aeration of the sand charges.

The sand underflow from the sizing cones passes to the leaching department, where it is delivered to four leaching tanks by an automatic distributor. The tanks have dimensions of 24 ft. × 10 ft. and are equipped with wooden filter bottoms of special design. The residue is sluiced to waste through an 18-inch terra-cotta launder. The effluent discharges to the sump tanks by way of two 4-inch pipes. There are four sump tanks, each 20 ft. × 10 ft. in dimensions. Two zinc belts near the sump tanks feed zinc dust automatically to a mixing cone



STOPPING IN EMPIRE MINE

where a small quantity of barren solution is added. This is delivered to two 5"×5" Aldrich triplex pumps. The solution is elevated by these pumps to two filter presses of 250 tons capacity. The filtered solution flows to the 20'×16' storage tank. Recovery is said to be excellent in every way, and the plant has proven very efficient. Formerly it was the practice to treat the tailing on canvas tables and Gates vanners, but the cyanide process has effected a much larger and more satisfactory recovery than the old method. The Empire Mines Co. is a close corporation. George W. Starr is manager.

乘 乘

Joplin District Zinc Notes

Wire-Rope Haulage in the Elizabeth Mine.—J. J. Thomas, of Webb City, has installed an underground rope haulage in the Elizabeth mine on the Avondale tract, east of Prosperity. The rope haulage operates over 350 feet of tracks, power being obtained from an electric motor stationed at the bottom of the 170-foot deep shaft. The haulage is on the endless rope system. Motors of five electric horsepower furnish sufficient power to handle a string of from 8 to 12 loaded cars, one man doing the work of running them to the shaft, where, by the old system of tramming, it required six men. About 500 cars a day are being handled by this cable system, although the drifts are not straight and there are a number of curves. It is stated that

the cost of power for the cable line is 30 cents a day, and the saving in labor amounts to \$125 per week.

The Midway Mine to Be Unwatered.—The old Midway mine in East Joplin, which was once a large producer of zinc ore, is to be pumped out. Pumps have been installed for this purpose and a new company intends to unwater the mine and go into the old workings, it being believed that with the modern methods of treating ore this old property will again pay.

Hill Top Drilling.—At the Catharine mine on the Mexico-Joplin land at Thoms Station, a drill hole is being sunk on the top of the highest hill on the lease. Heretofore, it has been customary to do drilling in the valleys, and all the prospecting has been confined to these places. The hill-top drilling is proving more successful in many instances and the prospectors are leaving the valleys for these high places both to drill and sink shafts.

Rapid Shaft Sinking at Johnstown, Mo.—The American Zinc, Lead and Smelting Co. are sinking a shaft on Davey Hill, at Johnstown. This shaft, which is to be one of the largest in the district, is 9 ft. × 16 ft. inside measurement. It is being rapidly sunk, at the rate of about 55 feet a week. Three shifts of men are at work in cleaning up and in drilling. It is hoped that the shaft will be completed in about 7 weeks, and then an air drift will be made from it to other shafts 1,000 feet away. This drift will be 8 ft. × 8 ft. in size and will be driven probably from both ends. If the enterprise proves as successful as is anticipated, a new mill larger and better than any on Davey Hill will be constructed and added to the active ore producers of the American company.

Jersey Bull Mine.—Rich zinc ore is being taken from the new shaft of the Jersey Bull Mining Co., operating on the Mexico-Joplin land at Thoms Station. Before the shaft was put down five prospecting drill holes were made and all five it is said went into ore, the clippings from one of the richer holes assaying 18.85 per cent. blende for 23 feet in depth. The shaft has reached this ore at 162 feet in depth, and is now working through it, but the company will sink to the bottom of the formation before turning drifts. Harry Hazel, one of the company, stated that a 200-ton mill would be erected as soon as the ground was sufficiently opened to warrant. The material now taken from the shafts is even richer than the drill holes indicated.

The Arkansas Zinc Mines.—The North Arkansas zinc field, which lies along the White River Railroad, is shipping from 15 to 16 cars of concentrates monthly. This concentrate is produced in what is known as the Rust Creek district, on Buffalo River. The shipping point is Buffalo, in Baxter County, and it is expected that by fall this district will be producing from 15 to 25 cars of zinc concentrate monthly.

Oklahoma Zinc District.—During the month of July the shipments from Miami, Okla., had been in excess of 1,000,000 pounds of blende. It is stated that this is due to the unloading of the big surplus heaps at the Turkey Fat and Newstate mines. Many of the mines of the Miami camp are running steadily and a good output is expected from now on.

Zinc Production in 1911.—Statistics compiled by the United States Geological Survey show that the production of spelter or metallic zinc from ore for the first 6 months of 1911 was 140,196 short tons, a gain of more than 5,000 tons over half the record output of 1910. Of this production, 5,135 tons was made from foreign ore. Spelter stocks were reduced from 23,232 tons to 17,788 tons. Imports remained about the same, but exports were nearly double those of half the preceding year. The apparent consumption of spelter was 135,497 tons, an increase of more than 12,000 tons over the half of 1910, but about the same as in half of 1909. The average price of spelter at St. Louis for the period was 5.36 cents per pound, the London average being .2 cent less per pound. During the latter part of May and the first part of June the average London price was about .1 cent higher than the corresponding St. Louis prices. Under this stimulus the May exports of spelter, zinc ore,

and dross were largely increased over those of the preceding months.

Rescued After 76 Hours.—Joseph Clary was imprisoned in a prospect drift of the White Oak mine east of Joplin by the ground caving into the shaft and shutting off his escape. Three drill holes were put down without striking his place of imprisonment, but after about 3 days the fourth hole entered the drift and made it possible to feed and communicate with him. In the meantime haste was made in clearing the shaft so as to rescue him, and this was accomplished after 76 hours continuous work. Mr. Clary says that the water rose higher and higher, and it was up to his armpits when he was rescued.

來 來

Treating Low-Grade Zinc Ore

By Lucius L. Wittich

At the Hackett Mining Co.'s property, on a 40-acre tract owned in fee by the company, west of Joplin, Mo., the mill recovery is 2½ per cent. ore, of which four parts are zinc blende and one part is galena. The blende will assay 61 per cent metallic contents; the galena will run better than 80 per cent metallic lead. The ore is extremely "chatty," that is, the zinc blende and lead particles have a tendency to adhere to the flint, after crushing, and because of this it is difficult to prevent a considerable quantity of the metallic substances escaping in the tailing. Through the introduction of chat separators, flumes, and chat jigs, an additional recovery of one-half of 1 per cent of the concentrates has been accomplished. The methods by which this additional recovery is secured are new to this district; and in some other respects the mill treatment is materially different from that employed locally.

Fig. 1 shows an exterior view of the Hackett plant which was built at a cost of \$100,000 and which is perhaps the most substantially built mill in the Missouri-Kansas-Oklahoma district. It is a double-unit mill with a total daily capacity of 600 tons. Two shafts are in sheet ore at a depth of 200 feet. A third shaft has been planned and is to be sunk soon. When sufficient ore can be secured the mill is to be kept running double shift, handling almost 1,200 tons of ore a day.

That 2½ per cent of mineral to 1 ton of rock may be handled at a profit in proportion to the heavy initial investment, the recovery must be as complete as possible. To avoid a heavy tax on crushers and rolls, the sizing of the ore begins early and is followed more minutely as the milling process advances.

The main shaft is 5½ ft. × 7½ ft. and is cribbed with concrete between timbers down to the limestone, a depth of 40 feet, to prevent surface seepage. The frame cribbings, composed of 2" × 6" timbers, are built with a space between of 1 foot, this being filled with concrete. The foundations of the mill, the floors, and many of the outbuildings are of solid concrete. A well 1,000 feet deep supplies pure water. The company generates its own electricity for lighting the buildings and the underground workings. Gas engines run the mill and hoisters, but there is steam equipment for emergency.

From the hopper, the ore is fed to two grizzlies, one with the bars 4 inches apart, the other 1 inch. All mill material must pass through the 4-inch grizzly. If too large for this the pieces are broken with a sledge. From the larger grizzly the

ore goes to an 18-inch crusher and then to a set of 36-inch rolls. All crushing is dry, the heavy expense of hoisting water to this elevation thus being avoided. The mill is equipped with two 18-inch crushers; two 36-inch rolls; four 30-inch rolls, and three 24-inch chat rolls, making a total of two crushers and nine sets of rolls. Undersize from the 1-inch grizzly goes to an elevator and is hoisted to an impact screen; it thus escapes the crushers and in this manner a heavy daily tonnage is diverted from passing through the crushers. Oversize from the grizzly goes to the crusher. From the first impact screen, undersize from a ¾-inch mesh goes to the rougher direct, while the oversize goes to a set of 30-inch rolls and is returned to the impact screen. Undersize from a second impact screen of 2-millimeter mesh goes to the cleaner direct; oversize goes to the rougher.

From the last three cells of the 6-celled rougher jigs the chats, which otherwise would escape in the tailing, are drawn off by the introduction of an ingenious device. At the foot of each of the last three cells on each set of roughers, making a total of six cells thus equipped, sheet-iron partitions are placed across the bed. These partitions are three feet long, enough to reach entirely across the cell, which is three feet wide and four feet long. The metal partition is as high as the dividing wall between the cells, and between it and the dividing wall a space of several inches is left. At the top the metal partition



FIG. 1. HACKETT MINING CO. MILL

is curved to fit securely to the partition wall. Horizontally across the metal partition, 1½ inches from the screen of the cell, a slot, 1½ inches wide is cut. This slot extends entirely across the partition with the exception of a small space left in the middle to make the device firmer. The cell, when properly bedded, is about 1½ inches deep in zinc blende and lead. Just above this stratum is the layer of chat, and the slot in the metal strip permits this material, instead of passing off as tailing, to flow through into the opening between the metal strip and the dividing wall or end wall of the cell, whichever the case may be. A spigot on the exterior permits the chat to be drawn off and pass to the chat rolls, where it is ground finer and passed to the chat jigs and then to the sand jigs.

In the slime departments the equipment also is especially thorough. In the early days of mining development in the Joplin district, when only the rich ores were developed, little attention was given to reclaiming sludge ore. Tables and sand jigs were unheard of. The Hackett mill is equipped with eight tables. Four only are now being run. These four produce one ton of ore per day, valued at \$40. This is greatly in excess of the cost of operation. Double partitioned settling boxes are used, and all slime possible is separated before the water passes to the settling tanks from which the final recovery of the fines is made. When the water finally reaches the sludge pond it is clear and contains barely a trace of zinc or lead.

Mining in Poverty Gulch Mine

The Shrinkage System of Mining. Method of Cost Keeping and Accounting

By Charles W. Henderson, E. M.*

The shrinkage system of mining is adopted at the Poverty Gulch mine with overhand stoping. There are five raises for manways and for ventilation. At 6 feet above the levels a second or sublevel is driven. Every 30 feet along the main levels chutes are placed.

In stoping, these subdrifts are expanded to the full width and length of the ore body. No timber is needed, the miner standing on broken ore, only enough being drawn off to allow for the extra space occupied by the ore when broken.

The 154,900 tons partly blocked out when prospecting are now fully blocked out. Of this, 1,066 tons was sold when prospecting, and 6,190 tons were taken out in development (in running drifts), but not sold. There remains therefore 147,344 tons of ore blocked out. If 10 per cent. of the original ore is allowed for pillars, there remains 131,854 tons.

Sampling shows this ore to run from a trace of gold to 7.5 ounces per ton, with an average of 1 ounce per ton.

Stoping is started on the first level. Every ton of ore broken makes 21.5 cubic feet loose, or .423 of a ton is drawn off every day, leaving in stopes .577 of a ton.

There are 29,908 tons of ore above the first level. To mine this will require 25 men excavating at the rate of 200 tons a day,

tons having been drawn off, and 17,135 tons left in stopes), leaving 72,146 tons to be broken.

Naturally, during the above 149 days, the shaft would be sunk further, another level run, and ore blocked on the third level.

Assuming that no more development work is carried on and that all the ore blocked out is marketed.

However, to maintain an output of 200 tons a day after the ore is drawn from the first level and until all the ore is broken in the second level, $200 \div .423$, or 473 tons, will have to be broken every day and 58 stopes will have to be worked until the second level is all broken. The ore on this level is 72,146 tons, and to break this ore will take $72,146 \div 473 = 153$ days, and if 30,600 tons is drawn off, there will be 58,681 tons left broken in stopes.

To exhaust the mine by drawing off the 58,681 tons in 200 tons a day lots, it will require 293+ days. The results of the mining will then be in time and tonnage as follows:

	Tons
150 days, 25 men stoping, 85 tons a day hoisted	12,750
149 days, 25 men stoping 200 tons a day	29,823
153 days, 58 men stoping 200 tons a day	30,600
293 days, no men stoping 200 tons a day	58,681
745	131,854
Taken out in development and not sold	6,490
Marketed	138,344
Marketed in prospecting	1,066
	139,410

To market the 138,344 tons and figure costs of operations during the time shipping was in progress, with pay roll, etc., the proceeding may be carried on as in Tables 1 and 2.

TABLE 1. ORGANIZATION* (SURFACE AND UNDERGROUND) ORDINARY AT MINE

Manager				
Mine Superintendent			Accountant and Paymaster	
Mining Operations	Engineering Operations	Mechanical Operations		
2 foremen: 37 miners 3 trammers and muckers 3 timbermen	1 surveyor: (part year) draftsman and assistants (part year)	1 assayer	Master mechanic: 2 hoisting engineers 1 compressor man 1 electrician 1 machinist 1 helper 1 blacksmith 1 helper	Outside foreman: 1 carpenter 2 timber framers 13 ore sorters 2 laborers
Underground		Surface		

* Production, 200 tons a day, 25 stopers, 12 men on development.

150 days. During that time the production will be 85 tons a day, and there will be drawn off 12,750 tons, and 17,158 tons will be left in the stope.

The production can now be 200 tons a day from the first level alone, in case operations are delayed on the second, and there are 17,158 tons of ore broken in the first level and 101,946 tons available on the second level, so the requirement that there be a reserve 200 tons a day for 18 months, or 108,000 tons, is more than fulfilled.

From the time the prospecting is started to the day the mine is hoisting 200 tons a day, has been $894 + 150 = 1,044$ days, or 50 days under the 3 years allowed for development so as to hoist 200 tons daily.

The ore is not all drawn from the first level at the rate of 200 tons a day, but stoping is started on the second level with the 25 men breaking 200 tons a day in the stopes, of which 85 tons a day is drawn off and 115 tons is drawn from the first level.

This plan of operation will continue for 149 days (17,158 ÷ 115), when all the ore is drawn from the first level and 29,800 tons has been broken in the stopes of the second level (12,665

SHIPPING AND SELLING EXPENSES

	Per Year
Sampling	\$ 3,000
Assay controls	225
Supervising	2,100
Freight and treatment (549087 / 2.01)	269,160
	\$274,485

Ore Sorting.—During the 745 days of shipping, 138,344 tons are hoisted, giving an average of 186 tons a day. Of this 138,344 tons, 40 per cent., or 55,337 tons is fine and is sold without sorting; 16 2/3 per cent., or 23,104 tons, is picked ore, and is sold after sorting; and 43 1/3 per cent., or 59,903 tons, is waste.

GENERAL EXPENSES

	Per Year
Salaries of officers of company	\$ 6,000
Office expenses	600
Insurance	3,200
Telegraph and telephone	340
Miscellaneous (Christmas gifts, etc.)	4,000
Books and stationery	500
Postage	400
Total	\$15,040

SUNDRY EXPENSES

	Per Year
Legal expenses	\$3,000
Taxes	500
Dues Mine Owners' Association	50
Expressage	300
Donations	600
Total	\$4,450

Capital Required.—To the commencement of shipments, \$124,965.90 was required, and as the receipts from ore sales during prospecting and development amounted to \$121,324.47, there was a deficit when shipping commenced of \$3,641.43, which is only apparent, as shipping could have been continued during development work. The cost of operations for 745 days, 2 years and 15 days, during shipments, was as follows:

* Part of a graduation thesis describing the prospecting, development, and mining in Cripple Creek, Colo.

150 days, 25 machine men, at \$4.50.....	\$16,875.00
150 days, 2 trammers, at \$3.....	900.00
149 days, 25 machine men, at \$4.50.....	16,762.50
149 days, 3 trammers, at \$3.....	1,341.00
153 days, 58 machine men, at \$4.50.....	39,933.00
153 days, 3 trammers, at \$3.....	1,377.00
293 days, 3 trammers, at \$3.....	2,637.00
For 745 days.....	\$79,825.50

TABLE 2. PAY ROLL EXPENSES FOR LABOR

Superintendence	Per Day	Per Year (Of 365 Days)
Manager.....	\$6.575	\$ 2,400.00
Superintendent.....	5.753	2,100.00
Total superintendence.....	\$ 12.33	\$ 4,500.00
(Underground)		
2 foremen, at \$4.50.....	\$ 9.00	\$ 3,285.00
37 miners, at \$4.50.....	166.50	60,772.50
3 trammers and muckers, at \$3.....	9.00	3,285.00
3 timbermen, at \$3.50.....	10.50	3,832.50
Total underground.....	\$195.00	\$ 71,175.00
(Surface)		
1 assayer.....	\$ 4.11	\$ 1,500.00
1 surveyor (not permanent position).....	2.05	750.00
1 draftsman (not permanent position).....	1.31	480.00
Assistants to engineering operations.....	3.29	1,200.00
Master mechanic.....	5.00	1,825.00
2 hoisting engineers, at \$4.50.....	9.00	3,285.00
1 compressor man, at \$4.....	4.00	1,460.00
1 electrician.....	3.29	1,200.00
1 machinist.....	4.50	1,642.50
1 helper.....	4.00	1,460.00
1 blacksmith and tool sharpener.....	4.50	1,642.50
1 helper.....	4.00	1,460.00
Outside foreman.....	4.50	1,642.50
1 carpenter.....	3.50	1,277.50
2 timber framers, at \$3.50.....	7.00	2,555.00
13 ore sorters, at \$3.....	39.00	14,235.00
2 laborers, at \$3.....	6.00	2,190.00
1 accountant.....	4.93	1,800.00
1 bookkeeper.....	4.11	1,500.00
3 clerks (\$1,000 per year).....	8.22	3,000.00
1 timekeeper.....	4.00	1,460.00
1 storekeeper.....	2.74	1,000.00
Total surface.....	\$133.05	\$ 48,565.00
Grand total.....	\$40.38	\$124,240.00

General expenses.....	\$ 30,681.60
Sundry expenses.....	9,078.00
Explosives.....	70,166.10
Power and lights.....	4,286.78
Water.....	6,000.00
Total cost of production.....	\$1,019,725.08
Total receipts from 131,854 tons.....	1,995,564.14
Profit.....	\$ 975,839.06
Profit per ton.....	7.41
Profit during active shipping.....	975,839.06
All previous sales of ore.....	121,324.47
Total profit.....	\$1,097,163.53

Depreciation and Amortization.—In this case where a mine has built up the plant out of the earnings, there is no calculation for amortization to be made, and for depreciation 10 per cent. has been allowed per year on all previous plant and equipment costs.

J. R. Finlay, former manager of the Portland Gold Mining Co., of Cripple Creek, Colo., has devised a cost-keeping synopsis that seems to be one of the best of various systems. In this the natural subdivisions of expense are called stoping accounts, and include the cost of breaking the ore in the stopes and delivering it to the trammers; that is, the labor of miners, machine men, and shovelers, cost of explosives, operating machines, etc.; the cost of taking ore from the stopes and delivering it to the shaft, which includes the labor of trammers, cost of tracks, repairs on cars, etc.; the cost of timbering the stopes in labor and supplies; the cost of raising the ore to the surface, which includes the cost of power, labor, and repairs in operating the hoists, and repairs to shafts; the cost of concentrating ore by hand labor in the ore houses, loading it on cars and shipping it; also the cost of all repairs on ore houses; the cost of draining the mine; the cost of electric lighting and candles; the cost of sampling and assaying in the mine; a small amount of surface expense that cannot easily be charged to other accounts; all engineering expense; officers salaries and office expenses at the mine; directors' salaries and office expenses at Colorado Springs; insurance and taxes on all mining property; all legal expenses connected with the mine; the cost of all exploring work that has produced any ore.

The above accounts are considered to be indispensable at all times to the operation of the mine. The following accounts are also indispensable to the success of the mine, but they represent investments and can be controlled in their amounts at the pleasure of the management. They are classed as plant and development accounts:

Drifts; cross-cuts; raises; dead work; exploring for ore. The cost of sinking new shafts is an account that has nothing to do with repairs or operation of shafts already completed.

The cost of cribbing in connection with the support of waste dumps is an account which is kept separate by reason of certain arrangements with railroad companies regarding this expense.

Machinery, buildings, investments in new plant is another account.

To the accounts mentioned are charged all the expenses incurred by the mine. The amounts charged will not necessarily correspond exactly with the total expenditures shown by the treasurer's statement because the mine accounts represent supplies that are actually used. It may happen that a certain amount of explosives, lumber, and timber, or supplies may have been bought that have not been used and are on hand. Whatever discrepancies there may be from this source will be very small. To the stoping accounts are charged all of the general expenses of the company, such as insurance and taxes, litigation, etc. To the plant and development accounts are charged only the labor and supplies used in doing the actual work. Not even the labor of the shift bosses is charged to these accounts; the idea being to have the statements in such shape that they will show exactly what expenses could be cut off by stopping any portion of the plant and development work that is going on.

The cost of explosives during stoping and shipping was:

131,854 tons × 4 = 527,416 pounds powder, at \$.127.....	\$66,981.83
131,854 tons × 4.1 = 540,601 feet of fuse, at \$.0035.....	1,892.10
131,854 tons × 1.4 = 184,596 caps, at \$.007.....	1,292.17
	\$70,166.10

The power and light costs for 745 days were:

Power for hoist, 87,200 kilowatt hours, at \$.005.....	\$ 436.00
Power for compressor, average 22 drills, 472,000 kilowatt hours, at \$.005.....	2,365.00
Power for blower, 37,300 kilowatt hours, at \$.005.....	186.50
Power for lights, 69,732 kilowatt hours, at \$.005.....	348.66
Candles, 65,560, at \$.0145.....	950.62
Total.....	\$4,286.78

Value of Ore Shipped.—The 59,903 tons of waste has a gross value of \$2 per ton = \$119,806; the 138,344 tons of ore has a gross value of 138,344 × \$20.67 = \$2,859,570.48; therefore, the 78,441 tons shipped has a gross value of \$2,739,764.48, or \$34.93 per ton, or 1.6896 ounces per ton.

RECEIPTS FROM ORE SHIPMENTS TO U. S. R. & R.

Gross Weight Tons	Moisture Per Cent.	Net Weight Tons	Assay Au Ounces	Value Per Ton	Total Value
78,441	4	75,303.36	1.6896	\$33.792	\$2,544,651.14
Freight and treatment at \$7 per ton.....					549,087.00
Net receipts.....					\$1,995,564.14
All previous ore sales.....					121,324.47
Total receipts.....					\$2,116,888.61

RECAPITULATION FOR 2.04 YEARS

All previous costs.....	\$ 124,965.90
Repairs on plant and tools.....	12,000.00
Superintendence.....	9,180.00
Underground { Machine men and muckers.....	79,825.00
{ Two foremen.....	6,701.40
{ Three timbermen.....	7,818.30
Surface pay roll.....	99,072.60
Shipping and selling.....	559,949.40

In order to work out the above costs it is necessary to keep a number of other accounts, called distributed accounts, from the fact that they do not figure by themselves in the cost per ton, but are distributed into the above mentioned accounts. These are as follows: Cost of operating compressors; cost of operating hoists; electric plant; general expenses connected with tramming, such as oiling cars, laying and repairing tracks; general expenses connected with timbering, such as filing saws, etc., that cannot be charged out directly; machine shop; blacksmith shop; carpenter shop; machine drills; explosives; cost of lumber and timber purchased, together with expense of unloading and delivering it where needed; supplies; surface expense, such as labor used in taking care of the surface arrangements, unloading and disposing of supplies, etc.; fuel account, which includes the purchase price and the cost of unloading coal.

采 采

Copper Mining Notes

Greene-Cananea.—The Greene-Cananea Copper Co., Cananea, Mex., has resumed operations at the Puertocitos property, which has been idle some time. The operations will be conducted on a much larger scale than they were when the property was last in operation, and besides the quarrying there will be some underground work done. The ore body at the Puertocitos mine is said to be 800 feet wide at the surface with a band of richer ore in the center about 200 feet wide. The ore was formerly mined in benches 100 feet apart up to the time of ceasing operations, and work had been advanced 125 feet or more into the ore without a sign of passing through the carbonates. It is estimated that there are 1,000,000 tons of this ore yet to be mined.

The Greene-Cananea has practically completed the construction work that will do away with an expense which equaled last year $1\frac{1}{2}$ cents per pound on the production. Figuring on the basis of last year this would reduce the cost of producing copper to $9\frac{3}{4}$ cents. The company has been producing at the rate of about 43,000,000 pounds per annum, but it is claimed that the property and the plant will soon be in a position to produce at the rate of 75,000,000 pounds per annum, and at a cost of 9 cents per pound.

Giroux Copper Property.—The five-compartment shaft of the Giroux mine will be sunk to the 1,800-foot level, thus making it the deepest shaft in Ely, Nev. To prevent the Alpha shaft of the old company caving into the 1,400-foot level of the present company a detour has been made about it. Because of the old shaft getting out of plumb and parting the 6-inch water column in three places, the timbers have been relieved of this weight by removing the column to the new shaft and holding it on I beams sunk in cement and not by the shaft lining.

Utah Copper Mills.—It is expected that the Magna and reconstructed Arthur mills of the Utah Copper Co. will have the capacity of treating 20,000 tons of low-grade porphyry copper-bearing rock daily. Neglecting Sundays, this is approximately 6,000,000 tons of rock yearly. If the recovery is 1.5 per cent. from 2 per cent. copper rock the output would be 180,000,000 pounds copper yearly.

Ray and Chino Mines.—D. C. Jackling, who developed and put in operation the system of milling followed by the Utah Copper Co., is so well satisfied with its success that he will probably introduce it at the Ray and Chino porphyry copper properties.

Shannon Copper Mine, Ariz.—Thompson, Towle & Co. assert that the Shannon Copper Co. is now producing its copper for about 11 cents per pound. The Shannon mine is at Clifton, Ariz. Recently the directors of the company voted to retire the last \$59,000 of its outstanding bonds at par, this being the remainder of the \$600,000 of bonds issued to pay for the smelter when the company was first organized. The company has, during the past few years, diverted about \$700,000 of net

profits derived from the production of copper back into the property, including the expenditure of about \$200,000 on smelter reconstruction, \$200,000 for additional properties, \$250,000 of bonds retired, \$40,000 for a water supply, \$25,000 for new houses for employes. The Shannon-Arizona Railroad is said to be earning a surplus for the Shannon Copper Co. of between \$20,000 and \$30,000 per annum after meeting all interest on its bonds.

Kingston Camp, Ariz.—C. T. Brown, of Socorro and Magdalena, N. Mex., has been acquiring in one way or another by location or purchase about 30 claims of the Kingston mining camp. It is presumed that he is working in the interest of Phelps-Dodge Co. The Kingston ore is a low-grade copper ore but exists in immense quantities, and whether high-grade ore exists in the hills is a matter of speculation.

Calumet & Arizona.—There are few shares of the Lake Superior & Pittsburg Copper Co. that have not been exchanged for the Calumet & Arizona at Bisbee, Ariz. It is said that the combined properties make it possible to work more cheaply than when they were operated singly, and this means a reduction in the cost of production of copper.

Utah-Nevada Consolidated.—The alterations and improvements now being made at the Magna and Arthur plants of the Utah-Nevada Consolidated Copper Co. will shortly be completed. This will give the mills a daily ore capacity of about 20,000 tons, so that the company will be in a position to materially increase its output when conditions in the copper metal market warrant such action. The output of the Nevada Consolidated during the last 6 months is about that of the production for the first half of last year. This company is in a position to put out a much larger quantity of copper than it has been producing.

Calumet & Hecla.—While the courts are passing opinions on the attempt of this organization to merge its associate companies into one corporation, the company is doing considerable in the way of exploring lands it possesses and upon which very little work has heretofore been done. It is stated in *Iron Ore* that in one property in Ontonagon County rich copper mineral has been found with a diamond drill, and while this boring does not show a mine, it does show that there is a lode that is at least as rich at one point as anything yet revealed in the Michigan copper field. All the shareholders in the company are anxiously awaiting the decision of the courts in which opposition to the proposed merger has been started. Thus far the decisions have favored the Calumet & Hecla Co.

采 采

Hydraulicking with Waste Water

By Lucius L. Wittich

At the tailing plant of the Connecticut Concentrating Co., on a lease of the Granby Mining and Smelting Co.'s land, at Chitwood, a suburb of Joplin, Mo., waste mine water has been pressed into service and is successfully taking the place of two teams and two drivers, and is thus saving the operators a big financial item daily. The water is used to wash the tailings to the mill, a series of concrete-lined flumes, Fig. 1, having been constructed through which the material passes by gravity to the mill.

Where tailing heaps that are to be remilled are situated on a slight slope, this system of washing the dirt to the mill may be successfully employed, provided, of course, the water supply may be obtained at small cost; otherwise, the added cost

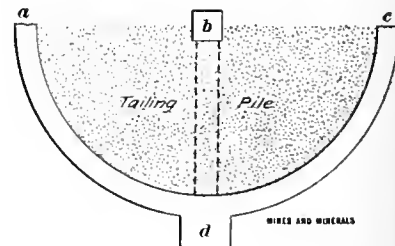

FIG. 1. PLAN OF FLUMES

of water would more than overbalance the money saved in the wages of teamsters and scrapers. In virtually all of the tailing operations of the Joplin district the common road scraper has been employed to convey the tailings to the mill. This process, of a necessity, is expensive, as the number of scrapers must be increased where the daily capacity of the mill is large. Due to the peculiar rolling character of the surface it would be possible in almost every instance to employ the hydraulic method as inaugurated by the Connecticut company, of which Lucius A. Barbour, of Hartford, Conn., is president, and Clarke Marshall, of Joplin, general manager. Mr. Marshall estimates that the daily saving is more than \$10, and that this item will be materially increased when the plant is running full capacity.

The tailing heap to be worked contains approximately 1,000,000 tons of dirt, and the mill recovery to date has been about 1½ per cent. zinc blende. Around two sides of the tailing, concrete flumes have been constructed. A third flume extends directly beneath the pile, opening at a point high up the hillside and directly in the center of the tailing pile.

The flumes are 18 inches in width. Flume *a*, Fig. 0, circles to the south of the pile. At the upper end it is 4 feet deep and has a fall of 20 feet, emptying into the hopper *d*. Flume *b*, which runs beneath the center of the pile, has a fall of 40 feet. Flume *c*, which circles to the north, has a fall of 30 feet. All flumes are of equal width, are 4 feet deep at the upper ends, and all empty into the hopper, which is 12 feet in depth. From the hopper the tailing is elevated by bucket elevators to the screens, rolls, tables, jigs, etc.

Water for washing the tailing into the flumes comes from a centrifugal pump stationed in the sludge pond of the William mine, which is operated by the owners of the Connecticut. Thus the water is secured at a minimum expense. Were it not utilized in some manner it would go to waste. A 2-inch rubber hose, equipped with a 1-inch nozzle, is employed and a pressure of 100 to 200 pounds applied. This gives ample power to the stream that plays against the tailing. One man has charge of the hose and he is enabled to wash more than enough gravel into the flumes to supply the mill. By directing the stream of water this way or that way he is able to wash away any desired portion of the tailing heap.

In addition to the novel method of conveying the tailing to the mill, the Connecticut company has erected the only cyclone-proof plant in the district. By spending several hundred dollars extra to procure braces for the tailing elevator and other parts of the mill exposed to heavy winds, the company already has profited. Recently the district was visited by a severe cyclone that left many damaged mining plants. Although in the path of this storm, the Connecticut mill was not damaged.

The tailing is screened through a trommel of 1½-millimeter mesh, the sand passing directly to the tables. Only the chatts from the rougher jig are reground, much of the waste being retreated in the form in which it is found in the tailing pile. As a result the second crop of tailing is composed largely of choice flint pebbles, from which virtually all the ore has been removed, and which is ideal material for use in concrete for building purposes.

柔 柔

Personals

R. B. Brinsmade is spending the summer in Mexico, and is examining mines in various districts.

Philip Godwill, of Bramwell, W. Va., has been visiting old friends in Scranton and vicinity.

J. R. Finlay has been engaged by the state of Michigan to estimate the ore in mines of that state for taxation purposes.

It is reported that Dr. L. D. Ricketts, general manager of the Green-Cananea Co., has been retained by the Arizona Copper Co. as consulting engineer.

Horace R. Lobdell, of Marquette, Mich., escaped death in

the Porcupine fire by digging a hole in the mud and remaining therein until the fire passed over.

Edward L. Hermann, E. M., of Calumet, Mich., has returned from Porcupine, where he was at the time of the fire.

John C. Martin, of New York City, a coal mine owner in Cambria County, Pa., has gone for an extended trip to Europe.

Percy E. Barbour has changed his address from Tecoma, Nev., to care of Uwarra Mine Co., Candor, N. C.

W. J. Hall, of Wallace, Idaho, has been appointed assistant general manager of the Federal Mining and Smelting Co.

Rush J. White, former chief engineer of the Federal Mining and Smelting Co., has been appointed superintendent of the company's mines.

In the article entitled "Coal Mines of Dawson, New Mexico," which appeared in the June issue of MINES AND MINERALS, the name of the general manager was given as E. L. Carpenter. Since Mr. Carpenter's resignation T. H. O'Brien has been general manager.

Boyd Dudley, Jr., instructor in metallurgy and ore dressing at the Missouri School of Mines, has been granted a leave of absence for the school year beginning September 1, 1911.

H. A. Roesler, of Youngstown, Ohio, a graduate of the Missouri School of Mines, has been appointed instructor in metallurgy and ore dressing at that institution for 1 year. Mr. Roesler has had an extensive experience in metallurgical work, and is at present in the employ of the Carnegie Steel Co., at Youngstown, Ohio.

Stephen L. Goodale, A. M., E. M., Professor of Metallurgy in the University of Pittsburg, is spending the summer in Newfoundland, engaged in some special engineering work for eastern capitalists who have mining interests there.

A communication under date of July 24, from Mr. Geo. B. Hadesty, division superintendent of the P. & R. C. and I. Co., who is one of the party of engineers and mine officials accompanying Mr. Geo. S. Rice, of the Pittsburg Testing Station, United States Bureau of Mines, on an inspection trip to investigate European coal mining methods and safeguards against accidents, stated that the party had traveled about 2,000 miles through British coal fields, and learned a vast amount about British methods. They left Great Britain on July 25 for a trip of approximately the same length through continental coal fields. They expect to return home some time in September.

An esteemed correspondent and friend of MINES AND MINERALS, in a letter under date of August 10, says that the Personal Note in our August issue, crediting Mr. Baird Halberstadt, F. G. S., of Pottsville, Pa., with being the geological expert who established the identity of the B bed of the Lower Productive Coal Measures in the three suits instituted by farmers against the Berwind-White Coal Mining Co., is not in strict accordance with facts. It should have read that Mr. Halberstadt's investigations corroborated the contention of the company and other experts in the case that the bed being worked was the B bed. The nomenclature and identity of the B bed were definitely established by the surveys and reports of Mr. Edward V. D'Invilliers, geologist and mining engineer, of Philadelphia, in 1894, and even earlier than that through the report of Mr. Franklin Platt for the Second Geological Survey of Pennsylvania. In the trial of the case the testimony of Mr. Eugene A. Delaney, the very capable chief engineer of the company, coupled with his records clearly stated, showed conclusively the identity of the bed and left little for the succeeding experts' testimony to add. While our correspondent does not write with any idea of detracting from Mr. Halberstadt's professional ability, he is desirous that credit should be given where credit is due, a desire in which we know Mr. Halberstadt will join. While Mr. Halberstadt was employed as an expert in the case, and his report to the company corroborated fully the evidence of Mr. Delaney and others, he was not called as a witness because further testimony was not needed to sustain the contentions of the Berwind-White Company.

Relation of Forestry to Mining

Importance of Forests. Rules and Regulations Applying to Forest Lands and Mining Locations

By J. F. Lawson*

The relation of forestry to mining is a subject which the people of this country have begun to consider only in the last decade. It is a large subject, too large to settle easily while as yet so little is known of forestry and of mining.

Those who are engaged in forestry know that their work has come to public attention during the progress of the great movement for the conservation of the natural resources of the country, and indeed, has been largely the occasion of that movement. As a part of that movement, the United States has employed a large number of men in the effort to keep trees growing upon portions of the public lands where it is believed their presence is indispensable to the public welfare, and where, so far as known, nothing else will grow. It is believed the forests now on the public lands can be kept as a great storehouse in which nature will constantly replenish supplies of materials useful in nearly every art known to man and in none more than in mining. It is desired that forestry shall be a handmaiden unto mining and to every other industry; that the natural resources committed to our care shall not be wasted but shall be developed and utilized to the fullest extent.

We bear in mind that the miner is also engaged in the development of our natural resources. Under circumstances of hazard, the miner has added untold millions to the wealth of the nation. From the underground storehouses where they lie unused, performing no service, bearing no interest, he drags forth the valuable minerals that they may be fashioned and refashioned into the structures and instruments most serviceable to man. Hidden in deep crevices or far shooting veins, as though buried by some slothful and unprofitable servant, the miner finds these treasures and delivers them over to the exchanger to be set at interest and to make more wealth for their possessors, who have already been made rulers over many. But nature must not be misjudged. Whether the slow miserly accumulation of geologic ages or the instantaneous prodigality of volcanic upheaval, these treasures are the fruition of natural forces. Neither are these forces dead. Yet so slowly do they act that, compared with the time required to grind the golden path of the glacier, man runs his course like the flash of an electric spark. And if one looks forward toward another riving of the mountain's core whilst molten rocks form new veins to vivify a new mining district, it is evident that then will be no time or place for miners. It may be an opportune place for new-school journalists or a proper place for unregenerated lawyers, but not for miners. The harvest which nature has prepared can be garnered but once. The things which nature is doing now are studied only to learn what she has done in the past.

Slow is the growth of the forester's crop; so slow that the individual may hardly hope to gather the wealth of his lands but once. Therefore, the individual who came into possession of a forest has hewn it down to make room for a crop which turns to wealth more rapidly.

There have been established in all parts of these western mountains of the United States what are known now as the National Forests. In establishing these reservations it has not been the design to take exclusive possession of any tract except such as is believed to be better adapted to growing trees than to any other use. The administration of the Forest Service is directed to their management so that such areas will remain in trees for generation after generation until science demonstrates that they are worth more for something else.

* Law Office of Forest Service, Denver, Colo.

The people of the United States now own these forest lands, as they once owned all the other lands in the country. The people parted with the great bulk of their lands and almost immediately the forests thereon disappeared. Of the disappearance to make room for more valuable crops there can be no complaint, but millions of acres have been left a waste after the lumberman was through with them. Acting through Congress, to whom the care of these lands was committed, the people have adopted a policy of saving the forests on lands adapted only to forests by retaining the title and possession of the lands. That the people are entitled to do this needs no argument.

Article II, Section 1, of the Constitution, vests in the President the authority to carry into execution the laws passed by Congress. In the care of the lands, the members of Congress do not personally go upon the territory to protect it, but the Congress makes regulations regarding it, which, like other laws, are carried out as nearly as may be by the executive branch of the government.

The work of the executive branch is so great that, under the provisions of the Constitution and the authorization of Congress, it has been divided into various departments. In the Interior Department, the Commissioner of the General Land Office has charge of the public lands, their care and sale. In the Department of Agriculture, there is a Chief of the Weather Bureau, a Chief of the Bureau of Animal Industry, a Chief of the Bureau of Plant Industry, a Chief of the Forest Service, and other chiefs for various tasks committed to the department. The work of these bureaus is further subdivided, the chief of each branch and section working subject to the authority of his superior, until the final executive control is traced back to the President himself.

Such subdivision of authority is in accordance with the system of organization made under authority of Congress, specifically approved by each annual appropriation bill, and absolutely necessary to the transaction of public business. The acts of Congress and the orders of the President conferring upon the Forester, subject to the control of the Secretary of Agriculture and of the President, the care of the National Forests are as lawful, as constitutional, and as American in spirit as the command which the captain exercises over a battleship, or which the Commissioner of Patents exercises over the Patent Office.

The same necessity which required the setting aside of the National Forest lands and their administration under the auspices of the Government, requires a careful execution of the laws under which they may be appropriated to private use. Thousands of persons have taken advantage of the generosity of the Government and of the laxity in looking after its interests to locate mining claims where there are no minerals, and homesteads which they could not farm and never intended to farm. Every subterfuge which greedy and unscrupulous men could devise has been used to take from the people the title to valuable mineral lands, power sites, and large tracts of public domain, in a manner not contemplated by the law.

It is expressly set forth in the statutes that mining claims may be located only upon a discovery of valuable deposits, whether in lode or placer claims; that no location of a lode claim shall be made until the discovery of the vein or lode within the limits of the claim located; that 5 acres of non-mineral land non-contiguous to the lode may be patented when actually used for mining or milling purposes; and that patent shall not issue in any case until \$500 worth of labor shall have been performed in the development of the particular claim located.

It must be observed that these are not rules invented by the Forest Service. They are the statutes of the United States, enacted in due form by Congress, upheld by the Land Office and the highest courts in an unbroken line of decisions running back more than 35 years. Originating in 1872, these statutes are a reenactment and general application of local regulations almost universally established long before by the miners them-

selves. State and local regulations, so far as they do not conflict with the United States statutes, are still recognized by these statutes and by the officers who enforce them. Such, for instance, is the law which protects the prospector in the possession of his claim while he is doing the work necessary to discover valuable mineral thereon. To obtain this protection against individuals who would try to work the same ground, he must comply with certain regulations, which may vary in different mining districts, regarding the giving of notice of his operations on the claim.

Very many cases have been found in the National Forests where men, disqualified under the homestead laws, have tried to hold non-mineral lands in exclusive possession by asserting some claim under the mining laws. Congress has prescribed the procedure under which reservoir sites may be taken—yet, notwithstanding, many persons have attempted to hold these sites indefinitely by locating them on placer claims, and have even received patent. Other men have covered large areas with mere locations which they do nothing to develop and only maintain in order to secure damages from persons who would cross them with rights of way for reservoirs, ditches, railways, or transmission lines. They have attempted to tie up large areas of fine timber by such mere paper locations, and to prevent such timber being used in the development of the mines and towns nearby. Such illegal holdings have in some cases been continued for upwards of 30 years, no effort having been made to apply for patent.

A possession of this nature amounts to an illegal appropriation of the land. It is contrary to the system outlined by Congress for the disposition of public lands. It operates to defeat the reservation of these areas for forest purposes; for unless the forests are to be properly administered they would better not be reserved at all.

The homestead laws grant to persons duly qualified the right to take up 160 acres of agricultural land; but because a man has exhausted his homestead right, or is otherwise unqualified, officers of the United States are not justified in so misrepresenting the circumstances as to give him his farm under the mining laws. To require him to expend \$500 in mineral development, and to show a valuable discovery on each claim may deprive a poor man of a good farm which should be developed. The forest officers, however, have no more authority to report facts which do not exist in order to secure the allowance of a patent than they would have to make out a false pay roll in order to enable some one to tap the treasury. The right of the Forest Service and of the General Land Office to begin a general crusade to relieve poverty is no greater than that of the Treasury Department.

乘 乘

General Ore Mining Notes

California Zinc Ore Deposits.—The Uncompaghe zinc claims are located on Clark Mountain, 7,000 feet above sea level, in San Bernardino County, Cal. Clark Mountain is 20 miles west of the Nipton, while the property is 14 miles from nearest station on the Santa Fe Railway. The ore shipped from these claims to the smelters in Kansas averaged 44 per cent. zinc, 12½ per cent. copper, and 10 ounces of silver. One sample taken went as high as \$4 per ton in silver and \$414 in gold. Nothing is said relative to galena and pyrite, which in all probability will be found in an ore so mixed in metals as this.

Federal Mining and Smelting Co. declared its regular quarterly dividend on preferred stock in June, thus bringing the total disbursements to \$6,421,000 on preferred stock and \$2,718,750 on its common stock. The issued stock of this company is \$12,000,000 preferred and \$6,000,000 common. The company operates a number of mines in the Coeur d'Alene district, Idaho.

The New Hercules Mill, at Wallace, Idaho, is treating 400 tons of ore a day, and the claim is made that it gives a better extraction than any other concentrating mill in the Coeur d'Alene district. The Hercules mine, at Burke, Idaho, is said to be shipping from 500 to 600 tons of crude ore monthly to the smelter.

Ishpeming Iron Ore Development.—If the development of the iron ore lands west of Ishpeming proves successful it will demonstrate that this field is likely to extend in this direction. The mineral was found by the diamond drill and while the quality of the ore can be closely estimated by an analysis of the cores recovered, the quantity must remain uncertain. The most satisfactory and surest way to prove such deposits is to sink shafts and drive drifts; then the data obtained are thoroughly reliable, and from them the tonnage and approximate value can be estimated.

The Cleveland-Clijfs Co. built a change house for the men coming out of the North Lake mine which was connected with the shaft by a tunnel, the object being to prevent the men becoming chilled when they came from the mines in wet clothes. The same company is now constructing a change house at its Negaunee mine, in which will be hot and cold water baths, as well as shower baths. Any mining company which considers the comfort and health of its men will obtain more work per man than under unfavorable conditions.

Standard Silver-Lead Mill.—John A. Finch, of Spokane, president of the Standard Silver-Lead Co., operating at Silverton, British Columbia, states that satisfactory progress is being made with the installation of the 8,000-foot tramway and the 200-ton concentrating mill, and both were expected to be in operation in August.

Sale of the Le Roi, B. C., Mine.—The famous Le Roi mine, at Rossland, British Columbia, has been acquired by the Consolidated Mining and Smelting Co. for \$250,000. The Consolidated company is a Canadian Pacific corporation and owns a smelter at Trail, British Columbia. It is a securities holding company and controls through stock ownership the Center Star, War Eagle, and St. Eugene mines, also the Rossland Power Co.

The Big Tunnel Mines, at Greenwood, British Columbia, probably the first mining enterprise in America subsidized by a municipality, reports a vertical depth of 1,200 feet with rich ore showings. The Tunnel company will, when the tunnel reaches a length of 5,000 feet, receive the first instalment of \$50,000 which was voted by the citizens of Greenwood. At the present time the tunnel is 2,400 feet long and the lead was found at 1,800 feet from the mouth.

Hydraulic on Salmon River.—The Hydraulic Placer Co. commenced washing for gold in the Salmon River, 15 miles below the junction with Snake River, in August after over a month's work repairing the ditch and the flume. Nine hundred feet of steel pipe leading from the pressure box 150 feet above the giants has been installed, so the company has an unlimited supply of water which can be delivered to the nozzles at a pressure of 65 pounds, and it is estimated that 1,000 yards of gravel can be washed every day. The mines are owned by Spokane people.

Tuscarora, Nev., Mines.—Word comes by way of Elko, Nev., that the old Tuscarora camp has taken a new lease on life. Two cyanide plants have been put into operation and the tailings from the old Dexter and Grand Prize mines are being worked. These mines were once famous for their rich ore, and it is not uncommon for mine cars of ore from these properties to run as high as \$10,000. From them chunks of pure gold were frequently extracted. The actual work of unwatering the mines at Tuscarora has begun in a systematic and practical manner under the supervision of William A. Farish, Jr. Two large skips are raising water at the rate of 1,500 gallons a minute at the Dexter mine. As the other properties are at a higher elevation, it is probable that by unwatering the Dexter mine it will relieve the others. When work was begun the water

was within 8 feet of the surface. It is now nearly a quarter of a century since active work was carried on at the Tuscarora mine. At the time of their closing down they were paying well, but a heavy flow of water was encountered, and this fact, coupled with the low price of silver, caused a cessation of activities in the mines. The recorded output of the Tuscarora mine is \$40,000,000, and the depth of the deepest shaft is but 600 feet.

Gold Mining at Helena, Mont.—The Last Chance gulch, and others in the vicinity of Helena, produced over \$100,000,000 between the years 1864 and 1870. This enormous output was from placers which have been long exhausted, or practically so, unless there are some cases where they may be worked with modern machinery in the form of dredges.

The quartz mines of the Helena district, within a radius of 20 to 25 miles, have scarcely been touched. Although it is evident, from the quantity of gold that has been taken from the gulch that there still remain properties which will pay; namely, Drum Lummon, Bald Buttes, Jay Gould, and others, it is proposed now to prospect the vicinity with a view to discovering the lode from which the placer gold was derived, and it has been suggested that the Commercial Club, of Helena, outfit a few prospectors and in other ways encourage those who are seeking to find the ore deposits. A history of gold mining in Montana is interesting reading.

Litigation between the Montana Co., Ltd., and the St. Louis Mining Co., which has covered a period of about 20 years, is now at an end, and the St. Louis company has become the owner of all the property of the Montana Co., Ltd., including the Drum Lummon and adjoining plant at Maryville. The St. Louis company is now actively engaged in repairing the 60-stamp mill and getting the property ready for active operation.

The Jay Gould mine, in the Marysville district, is again in operation after a number of years idleness. The new developments are so encouraging that it is the belief that the Jay Gould mine, which is owned largely by citizens in Helena, may perhaps equal its record of former years. This mine is within about 4 miles of the town of Marysville.

Hydraulicking at Round Mountain, Nev., is going on, but owing to conditions which prevail in that country the ground is apportioned to men who are called percentage workers. These pile their gravel near the sluice and in turn are permitted to wash it into the sluice. One block of ground averaged \$21 per yard. This, however, was an exceptionally rich one. The season in this locality is limited, owing to the supply of water coming from the snow which melts from the mountains in the warm season.

Modoc Mine, Cripple Creek.—Word comes from Cripple Creek, Colo., that the Modoc mine has found a vein of silvrenite which varies from 12 to 14 feet in width at a point about 35 feet from the shaft. The vein has now been opened on the 5th, 7th, and 9th levels, and a cross-cut is being run to open it on the 200-foot level. Samples taken from the ore piles have assayed from \$1.40 to \$2.40 per ton. On the 9th level the ore has been drifted upon about 40 feet and continues to hold up in value.

Dalton and Lark Mines, Utah.—Carbonate lead ore has been found in the Dalton and Lark group of mines at Bingham, Utah. The Bingham Mines Co. has been working sulphide ore in these mines by means of raises from the 950-foot level. On the 750-foot level there was 4 feet of shipping lead carbonate ore exposed, and from that depth to the surface the ground has not been worked. This find is considered important, because it is 8 years since this mine produced carbonate ore.

Goldfield Consolidated Report—Preliminary report of the general superintendent, J. F. Thorne, of the Goldfield Consolidated Mines Co., shows that in May the company treated 29,410 dry tons, the largest tonnage handled in any single month in the company's history, and while the value, \$882,000 gross, and \$677,000 net, was below that of the two previous months, it was still considerably in excess of the amount required to

maintain the payment of dividends at the present rate of 50 cents a share.

Prospecting in Colorado.—The revival of prospecting in Colorado seems to be producing results. Word comes from Silverton, Colo., that Jedson Belenger began prospecting in the old abandoned mine on Sheet Mountain about 9 miles west of Silverton. Here he found ore about 450 feet from the portal of an old tunnel which cross-cuts the vein at a depth of 350 feet below the surface. The vein is said to be fully 3 feet of solid lead and copper sulphide and averages about 2.44 ounces of gold and 231 ounces of silver per ton.

Directly east of Steamboat Springs, Routt County, in the Gore range of mountains, several gold-bearing deposits, which are both smelting and free milling, are said to have been found. Development work in tracing these veins is now going on, although enough pay ore has been found to make possible the working of such producers. In another section of Routt County where gold-bearing quartz is found, and near Hahn Peak, placer mining is reported near the junction of Grand, Jackson, and New counties. Several prospectors in this field are grubstaked by Denver people and with some private funds of their own. The general instructions to the prospectors stated that the name of Charles A. Johnson, president of the Denver Chamber of Commerce, is to be placed on location and discovery notices, as a one-half owner, and they are further to follow the requirements of the law in every particular. Other instructions are relative to opening the veins at several points, making sure that the vein on the surface outcrop intersects at least one end line, making the discovery shaft or cut 10 feet deep or more, etc., A prospector's geological map has also been furnished them, it being based on the geological map of Colorado constructed by Hayden.

Humboldt Basin, Ore.—Mormon Basin, sometimes called Humboldt Basin, is the oldest mining camp in eastern Oregon. Its existence dates back to 1862 when placer gold was first discovered there. The camp, after long idleness, is now attracting attention by reason of its quartz mining possibilities. The Rainbow mine has recently been purchased by the United States Smelting, Refining, and Mining Co. At the Humboldt mine, owned by the Oregon-Idaho Investment Co., a force of miners is engaged in development. Altogether there is an activity at Mormon Basin which exceeds anything that has occurred since the early days.

Montana-Tonopah.—Development and prospecting work is being kept up in the Montana-Tonopah mine, Nevada, and ore is being found in the different cross-cuts driven on all levels. The mill of this company is doing excellent work and is said to be recovering 90 per cent.

Mining Luck.—An instance of rapid wealth making is reported from Nevada. Legal advice given to the men who first located the National mines at National, Nev., was paid for by a block of stock in National company. After holding this stock 3 years it has been sold for \$280,000. The National mine has been a sensational gold producer from the start, and such rapid wealth would probably not occur often, but you never can tell about lawyers.

Homestake, S. Dak.—According to reports from the Homestake Mining Co., of Lead, S. Dak., more rock is being hoisted with fewer men than during the period before the company's labor trouble. It is claimed that more efficient methods in the mine and less time is taken in explaining work, which, with the Slavonians frequently required the services of an interpreter, has much to do with the increased output. The last shipment of gold bullion was said to be the largest the company has had in years.

Florence, Idaho.—Modern machinery will be installed in the placer ground in the Florence, Idaho, district by a Spokane syndicate, headed by S. A. Anderson, formerly cashier of the Scandinavian-American Bank. The district was discovered in the summer of 1861 and the ground was successfully worked

for years by white miners, who afterward abandoned it to Chinese. The principal work this season will be on the bars and benches along Miller Creek. Heavy-pressure hydraulic giants are being installed and the volume of water in the streams selected as the source of supply for the pipe lines is sufficient to insure the working of the ground until the beginning of cold weather. Pioneer prospectors now living at Lewiston, Idaho, who were among the first in the rush into Florence from Orofino, 50 years ago, are watching the work of the hydraulic, some of them believing that what yellow metal the "rockers" and sluices left was cleaned up by the Chinese, who worked the ground after the white miners went to other districts. On the other hand, Mr. Anderson and experts express confidence in the placers returning dividends.

采 采

Porcupine Forest Fires

The forest fires, that occurred in the Porcupine, Ontario, gold district of Canada have so greatly retarded development work that it has been urged that the government grant a year's extension to complete development work on claims.

On May 19 a bush fire practically destroyed the Hollinger surface plant, which was moving along nicely toward completion.

On July 2 another fire destroyed the buildings of the West Dome property and seriously threatened the Pearl Lake. On July 9 the brush again caught fire from smouldering fires probably, since several were reported at different places, and swept almost the entire district on both sides of Lake Porcupine and raged several days, causing destruction to life and property, and entailing much hardship on the survivors. This fire destroyed several towns besides individual houses. Those people who escaped seem to be well satisfied that it was merely a property loss with them. Pottsville and South Porcupine were completely burned, while Golden City was nearly so. Survivors from the fire zone tell of narrow escapes and of people perishing who sought refuge in Porcupine and other lakes.

Daniel Yost and C. A. Burdick, of New York City, the latter a mining engineer, plunged into Goose Lake, on the King-Porcupine property. Manager E. P. Ashmore and Captain Shovell and wife, of the Philadelphia property, were nearly overcome while making for Porcupine Lake, 3 miles away, but were rescued by four Italians who were fleeing on a hand car; but even then when they neared the lake it was necessary to jump from the car and rush into the water.

Morgan R. Cartwright, treasurer, and R. E. Cartwright, of the Pearl Lake property, had a narrow escape from the flames. The Success claim, although in the fire zone, escaped. The manager, Ralph A. Meyer, had planned to clear around the camps but had not done so; however, none of his 50 men were injured, and the property became a refuge for 30 men driven from the south camp of the Crown Chartered Co. H. C. Meek, manager of the Dome, with his family and four men, sought refuge behind some water barrels on a rocky prominence, and by the aid of wet blankets survived the holocaust, although some of the men were badly burned protecting Mrs. Meek.

The Dome mine, which is probably the most extensively developed of any in the Porcupine, had about finished its 40-stamp mill, and the company hoped to have started it in August.

At West Dome, Robert A. Weiss, manager, with his wife, daughter, Angus Burt, and some 27 others, sought refuge in a timbered shaft and were suffocated. At the Dome shaft several who had taken refuge therein perished, including John Taylor, a mining student at Toronto.

At Preston, East Dome, no lives were lost, although some entered an untimbered shaft and passed up water to others. Captain John Wilson and some of the employes lay in a creek and threw water over each other. At Dome 57 men rushed into a pond, and so escaped destruction.

At the Imperial mine 16 boxes of dynamite were lowered

in the shaft, but the flames worked down the timbers and they exploded. Manager A. H. Crampton and Superintendent Joe Healy escaped and reported there was no loss of life at the Imperial. The Canadian Explosives Co.'s magazine containing 12 tons of dynamite exploded on the Foley-O'Brien property. A car of dynamite on the Lakeview-Porcupine exploded and added its quota to the general havoc.

The first reports coming from the fire zone exaggerated the loss of life, as is nearly always the case in times of excitement and uncertainty, and there was considerable anxiety experienced by those in Canada and the United States who had friends and relatives in the burned district until they heard definitely from them. The most noted prospector in Ontario, William Wilson, died from burns received while in the vicinity of the Dome mine.

Only a partial list of the money loss due to this fire ever can be given, as personal effects and property outside of the mining and railroad companies, which undoubtedly totals into thousands, will never be known. In addition to this loss of property, the loss in time will represent much to those whose money is invested.

A partial list of the damage done to mining companies is as follows:

Dome mines, all of their buildings, except Manager Meek's house. Loss close on to \$800,000; loss includes all their shaft houses, new 40-stamp mill, almost completed, and large up-to-date compressor plant.

North Dome mines, loss \$50,000; plant and camp destroyed.

Preston East Dome, loss \$150,000; plant and camps.

Vipond, loss \$100,000; plant and camps all destroyed.

Foley-O'Brien, total loss estimated about \$100,000.

Philadelphia mines, loss about \$50,000; buildings destroyed.

United Porcupine mines, loss \$20,000; all camps burned.

Eldorado Porcupine, loss small, buildings destroyed.

Standard Porcupine, loss of buildings totaling \$40,000.

Imperial, loss about \$35,000; all plant and buildings.

West Dome mines, plant and buildings; loss \$75,000 at least.

Crown Chartered, a total loss.

It is reported that the Hollinger, West Dome, Preston East Dome, and Dome companies have ordered machinery to replace that destroyed.

采 采

World-Wide Figures

Through study and observation of the volcanic outflow the geologist knows approximately the composition of the earth's crust to a depth of 10 miles below sea level. As Frank W. Clarke, of the United States Geological Survey, says in the "Data of Geochemistry," "this thickness of 10 miles represents known matter." The vastness of the figures which it is necessary to employ in the discussion of this 10-mile lithosphere, as it is termed, transcends ordinary human comprehension.

The volume of the lithosphere, including the continents elevated above the sea, is 1,633,000,000 cubic miles.

A cubic mile of average rock weighs 12,800,000,000 tons.

The volume of the ocean is 302,000,000 cubic miles.

The atmosphere is equal in weight to 1,268,000 cubic miles of water, which, however, is only one two-hundred-and-thirty-eighth of the volume of the ocean; yet this would be sufficient to raise the level of the ocean 45 feet on all shores and to submerge an important part of the continents.

One per cent. of the water of the ocean would cover all the land areas of the globe to a depth of 290 feet.

The salt in the ocean would make 4,800,000 cubes each 1 mile in dimensions, which, if spread over the United States, would form a layer 1.6 miles high.

In comparison with this outer 10-mile section of the earth's crust, the thin sheet of organic matter on the surface—the prairie and valley soils, the alluvial bottoms, and the rich table lands by whose products man lives—becomes a mere film, a skin.

The Elmore Flotation Process

The Specifications Showing the Original Claims for the Patents on Which the Process Is Based

The complete specification taken out by Francis Edward Elmore in 1900 (the first patent) relates to "improvements in separating metallic from rock constituents of ores by bringing a mixture of the pulverized ore with water into contact with more or less thick oil, which entraps the metallic constituents and allows the rocky constituents to pass away with the water. The thick oil is preferably the thick tarry residue of mineral oil after some of the more volatile constituents have been distilled off. When the pulverized ore has been mixed with water in quantity amounting to several times the weight of the ore, it is then mixed with the thick oil. The metallic constituents of the ore are retained in the oil, which does not even adhere to the previously wetted rocky or earthy ingredients, these being held in suspension in the water. The mixture of water with the earthy ingredients being allowed to subside as tailings, the more buoyant mixture of the oil with the metallic matters is separated from the oil, which can be used again for repeated operations. The tailing from the first operation may be again treated with oil in the manner described so as to recover such of the metallic ingredients as may have escaped the first treatment, and this may be repeated several times if necessary. Various apparatuses may be employed for operating." (Here is described one form which the inventor proved effective.) The claims in respect to this patent are:

"1. Process for separating the metallic from the rocky constituents of ore by mixing the pulverized ore, first with water in considerable quantity, then adding to the mixture an oil of the kind described, which adheres to the metallic constituents but not to the rocky wet constituents, allowing the water carrying the rocky material to subside while the oil carrying metallic constituents floats above, and separating the oil from these constituents, substantially, as described.

"2. For separating metallic from rocky constituents of ore, apparatus comprising horizontally revolving, helically ribbed mixing drums, subsidence vessels, a centrifugal drum for separating the oil, a tank provided with agitators, and a second centrifugal machine for separating the water arranged and operating substantially as described."

The complete specification of the patent taken out in 1901 by Alexander Stanley Elmore, relates to "Improvements in the process and apparatus for separating mineral substances by the selective action of oil." The specification goes on to say: The selective action of oil has been utilized for separating metallic substances from earthy or rocky constituents of ores. This has generally been done by pulverizing the ore and suspending it in a considerable quantity of water so as to make a freely flowing pulp, then mingling with it oil, preferably heavy oil, such as is obtained from petroleum after some of the lighter oils have been distilled from it. When the mixture rests, the oil, with most of the metallic substances entrapped in it, floats at the top, and is separated from the rocky or earthy matters which are run off with the water as tailings. The oil is afterwards separated from the metallic substances, usually by centrifugal action.

"In carrying on this separating process, it was discovered that in some cases a slight acidulation of the mixture greatly enhances the selective action of the oil, so that metallic substances, as well as other mineral substances, such as sulphur and plumbago, can be separated from the earthy matters, with which they are associated naturally, better than when there is no acid present. By this means some metallic substances can be separated from others, such, for instance, as sulphides from oxides. The acidulation may be effected either by adding a little acid to the oil, in which case an acid that will dissolve in

or mix readily with the oil, but which is insoluble, or nearly so in water, as, for instance, oleic acid, is to be preferred; or the acid may be added to the aqueous pulp, in which case sulphuric acid may be employed or the acid cuprous liquors obtained in mine working. The quantity of acid added in either case is small, as it often need not exceed one five-hundredth part of the volume of oil or water employed in the operation. The quantity of acid required to produce the best results varies according to the character of the material treated, and is not confined to any definite proportion. Not only oil, but also certain other fluids, such as tar or varnish, exert in a greater or less degree the selective action for separating minerals, and it is to be understood that in this specification where the word oil is used it includes those other substances which exert selective action like that exerted by oil. If plumbago, elementary sulphur, or other similar substances of like character are present, the oil attaches itself to, or coats such particles, while it does not coat or attach itself to the rocky or earthy particles present." (Here follows a description of the apparatus for carrying the process into effect and separating the metallic particles.) It is briefly as follows:

"A freely flowing pulp of water and oil is brought into a mixer, consisting of a trough having a rounded bottom and a shaft carrying a number of inclined agitating blades. To this is added oil which is thoroughly mixed with the pulp and the metallic particles issue by an opening at the end of the trough into a separate tank, where the metallic ingredients adhering to the oil are floated to the top and the earthy or rocky ingredients subside and are allowed to issue by a pipe at the bottom. The metallic ingredients, with the oil, are discharged into a drum of a centrifugal machine, in which a separation of the metallic matters from the oil takes place, and the oil being taken away for further use. Another form of apparatus is given for effecting the separation after the selection has taken place in the trough by attaching to the end of the trough a weir, having a number of wave-like blades or baffles by which the stream of pulp and oil globules is thrown against an apron. This apron is preferably made of canvas or some fabric not injuriously affected by oil, and its surface is continuously supplied from a pipe with fresh oil, which is evenly distributed over the apron of the spreader. This oil surface takes up most of the oil globules from the pulp, and also picks up such particles of metallic subsidences as may have escaped selection by the oil in the mixer." The claims set out by the inventor are:

"1. In processes for separating minerals by the selective action of oil, the addition of a small quantity of acid to the oil or water employed in the process or to both, substantially as and for the purpose set forth.

"2. Apparatus for separating minerals by the selective action of oils, comprising a trough containing a shaft carrying inclined blades adapted to revolve within the trough, a settling tank partitioned at the top, and a centrifugal machine adapted to revolve within a casing, constructed and operating substantially as described.

"3. Apparatus for effecting separation of minerals by the selective action of oils and like substances, comprising a mixer of the oil with the aqueous pulp of pulverized mineral, an incline for downflow of the mixture having steps or baffles, an endless apron, means of distributing oil over it, and means of causing it to travel in a direction opposite to the said downflow, a conical revolving sieve adapted to receive the discharge from the incline, a nozzle for delivering a shower of water over one side of the sieve, and two launders adapted to remove the matters that pass through, and the matters that are washed over the sieve, respectively, substantially as described.

"4. The combination of a stepped incline for downflow of the mixed pulp and oil, with a traveling apron provided with a distributor of oil over its surface, substantially as described.

"5. The combination of a conical revolving sieve, a distributor of a water shower over part of the sieve, a launder

adapted to lead off the matters washed over the sieve, and a launder lined with blanket adapted to lead off the matters that pass through the sieve substantially as described."

來 來

Laboratory Sizing Tests

By F. Curtis*

The ore dresser, who, in his laboratory work, is content to dry screen his finely ground material will find that his results are at times very misleading. The tendency of the very fine material and the slimes to cement either to the larger particles or to form lumps consisting mainly of the fines is a matter of common observation.

As a means of avoiding this difficulty, some authors have recommended the employment of a method of wet screening. That the results obtained in this way are inaccurate can be demonstrated by a simple experiment.

If a sample, which will be, say, 20 per cent. on 40 mesh, is wet screened by any process of manipulation which may appeal to the experimenter, and the oversize is allowed to dry without removing from the testing sieve, it will be found that a not inconsiderable amount of the so-called oversize will of its own weight fall through the meshes. This amount will be greatly increased by gently jarring the sieve, showing conclusively that the screening has not been thorough.

It occurred to the writer that if some means of eliminating the slime from the sample could be devised, the remaining portion could be accurately dry screened. After considerable experiment, a classifier was hit upon, patterned closely after the tubular hindered settling classifier described by Prof. Robt. H. Richards.

In the accompanying sketch can be seen the design of the apparatus used in the laboratory at the Steptoe concentrator. The essential features are a settling cone *a*, a roughing column *b*, a teeter chamber *c*, a pressure chamber and receptacle for the sample *e*, and a dial cock *f*, by means of which a very nice regulation of the flow of water to the apparatus can be maintained. A pinch cock can be used on the rubber connector *g* should it be desirable to interrupt the process of classification for any purpose. The apparatus can easily be constructed by any tinsmith at small expense.

The material to be sized is weighed out, about 1 kilogram being the size found most convenient in work. The classifier is partly filled with water and the pinch cock is closed on the rubber connector at *g*, the dial cock being set to give the desired current before this is done. Then the sample is charged in the apparatus, the pinch cock released, and the sorting begins. All overflow is caught and carefully settled and may be considered undersize of 200 mesh. It is well, however, to pass the overflow through a screen of this mesh, as this will prevent any light particles which are over this size being included in the undersize. It also serves to indicate the proper flow of water to use for sorting, as any considerable quantity of material

remaining on the screen will indicate that the quantity is too large. Twenty minutes' treatment with a gentle rising current will remove practically all of the troublesome material, leaving a clean sand, which is drawn off, dried, and carefully screened, using any desired series of sieves. The undersize of the finest mesh can be added to the fines collected in the overflow. But it is often convenient to make each of these a separate sample.

It is found possible to secure tests on duplicate samples that will check very closely, also samples run by different persons will agree more nearly than when the checks are attempted with the dry screening.

A comparison of the results of both methods shows in all cases that the amount of mineral in the finest size is greater when the process described is used, the increase in mineral sometimes being as much as 75 per cent. When the material happens to be tailing, the importance of locating the exact point at which the greatest loss occurs cannot be overestimated.

來 來

Settling Chamber for Smelter Fume

By J. I. Blair*

The general arrangement of this settling chamber depends on the principle, and makes use of the fact, that properly placed obstructions to the flow of a flume-laden gas cause such eddies as are seen in streams most prominently at the foot of bridge piers. Such being the case, it is assumed that more fume will drop out of suspension in such an arrangement as is here shown than would drop out of simply enlarged chambers, regular dust catchers, which depend on a swirling motion imparted to the incoming gas by placing the entrance at a tangent to one side

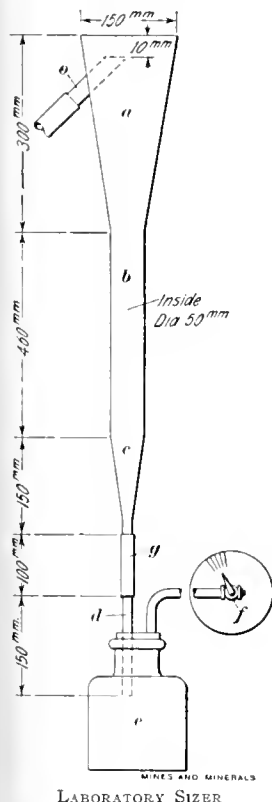

LABORATORY SIZER

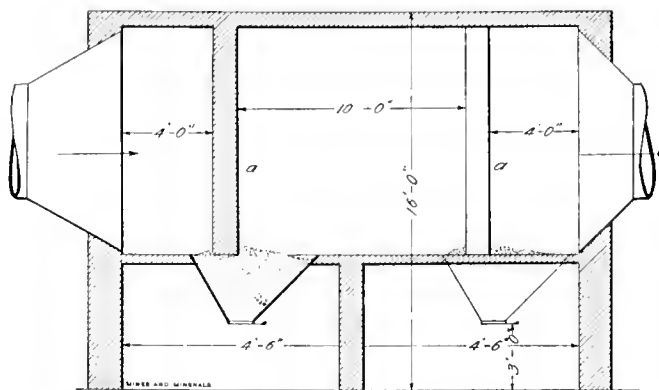

FIG. 1. SECTIONAL ELEVATION OF FUME CHAMBER

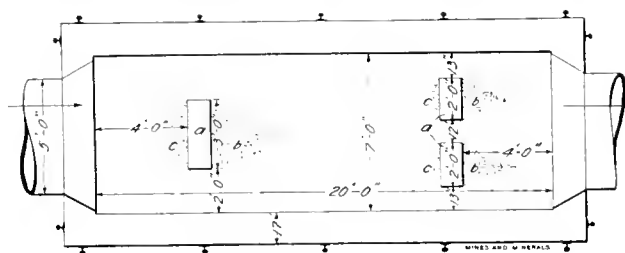

FIG. 2. PLAN OF SETTLING CHAMBER

of the circular chamber, or other devices which simply divert the course of the gas by abrupt turns, etc.

In Fig. 1 the position of the baffle walls, which are built of firebrick, are seen at *a*. The conduit pipe is flared out to cause the gas to meet the first wall evenly and avoid the accumulation of dust in the corners on either side of the entrance. The bottom of the baffle walls is arched over a trap door which per-

*Chemist, McGill, Nev.

*Metallurgist, South Bethlehem, Pa.

mits the fume which collects in front of the wall at *c* to be raked down into the hoppers from which it is allowed to drop into a tram car beneath.

The roof of the chamber is arched over, and the bottom is made by two layers of brick on a sheet-iron bottom.

In Fig. 2 is shown a plan of the chamber. The sediment of fume is shown as it would occur at *b* and also at *c*. The method of bracing the chamber with 60-pound rails is also shown.

來 來

Colorimetric Estimation of Gold

In a recent number of the *South African Mining Journal* Mr. William Bettel gives the following method of estimating gold in cyanide solutions:

Existing methods for the colorimetric estimation of gold in cyanide solutions are, occasionally, unreliable, through impurities present in the solution or reagents producing alterations in tint of the gold-purple which are not constant in "depth," and therefore interfere when comparing tints with "standards." Certain organic matters which collect in the final gold precipitate are attacked and dissolved by aqua regia with production of a yellow or brown color, barely visible to the unaided eye, but quite sufficient to alter the color of the gold-purple, so as to render comparison with standard tints of the "purple of Cassius" impossible.

This organic matter may come (in one modification of the process) from commercial sulphuric acid used in acidifying the solution prior to driving off the *HCN*, followed by precipitation by the zinc-lead couple; in others, by organic matters present in the precipitant (aluminium powder or zinc fume), or the solution itself. In all processes it has hitherto been thought necessary to get rid of the existing cyanide in the solution prior to precipitation of the gold, and in so doing, two out of the three processes cause the precipitation of ferrocyanides. Ferrocyanides, when treated with aqua regia, produce among the products of oxidation, ferric salts and hydroferricyanic acid. In the final stage of the process, when adding stannous chloride for the production of the gold-purple, the ferric iron is reduced to ferrous which acts upon the ferricyanide, forming a greenish or bluish coloration; this may be very faint, but it alters the color of the gold-purple, rendering its standardization almost impossible. When the ferrocyanides, and the organic matters, already referred to, are present together, this difficulty of comparison is increased, and when, by the use of varying weights of the reagents containing the organic impurities such tints vary in intensity, close comparison is rendered quite impossible.

With a view to removing the difficulties referred to, I commenced a research on the precipitation of gold from dilute cyanide solutions, by various precipitants, and finally selected, for use, a finely divided zinc-copper couple, made from zinc fume diffused in the solution to be tested, after the addition thereto of a measured quantity of strong cyanide solution containing a certain quantity of cuprous cyanide (the additional cyanide keeping ferrocyanides, and zinc cyanide to be subsequently formed, in solution). The solution is then heated and stirred vigorously to keep the "couple" in suspension until the gold is precipitated. The precipitation I found to be rapid and practically perfect; the filtrate, on being retreated, failing to give an appreciable tint of the gold-purple, even when viewed in a very narrow test tube (to increase the column of liquor to be viewed in the direction of its length), and compared with distilled water in a similar tube. I estimate that the gold remaining unprecipitated will not exceed .5 grain per ton of solution. The results obtained with all classes of solutions agree with the precipitation plus fusion and evaporation methods.

The remainder of the process is, with the exception of a

few manipulative details, essentially the same as that in present use. A measured quantity of zinc fume is, however, used for precipitation, and the alteration of tint due to impurities in the zinc fume is constant and therefore measurable, giving approximations sufficiently accurate for extractor-house work. The process is simple and can easily be carried out by the foreman in charge, or one of the shiftsmen. A test can be made in about 10 minutes.

For closer work, the final precipitate (free from ferrocyanides) is suitably treated for removal of zinc, and, subsequently, of the interfering organic matter. The resultant gold solution gives a "purple of Cassius" which, in all cases, can be exactly matched by the gold-purple produced from standard gold solutions. In all cases I prefer to remove suspended matters from the solutions to be tested, previously clarifying, if necessary, before measuring the solution for the test. This method, which is as perfect as any colorimetric process of its class can be, may be carried out in 17 to 20 minutes. The cost of the essay is trifling, while its advantages, especially in saving the time of the hard-worked assayer, are obvious.

來 來

Catalogs Received

AMERICAN BLOWER CO., Detroit, Mich., Bulletin No. 315, "Ventura" Disc Ventilating Fans, 20 pages; "A B C" Exhaust Fans, 20 pages; "Sirocco" Electric-Forge Blowers, 4 pages; "Ventura" Electric Ventilating Set, 4 pages.

THE BRISTOL CO., Waterbury, Conn., Bulletin No. 142, Bristol's Recording Water-Level Gauges, 24 pages; Bristol's Recording Instruments, Condensed Catalog No. 160, 64 pages; Bristol Recording Instruments, 8 pages.

THE BROWNING ENGINEERING CO., Cleveland, Ohio, Descriptive Catalog of Browning Locomotive Cranes, 55 pages.

CARNEGIE STEEL CO., Pittsburg, Pa., Furnace Slags in Concrete, 32 pages.

GENERAL ELECTRIC CO., Schenectady, N. Y., Bulletin No. 4802, G. E. Type "H" Transformer, 16 pages; Bulletin No. 4818, Couplings, 9 pages; Bulletin No. 4829, Electric Locomotives for Industrial Railways, 15 pages; Bulletin No. 4835, Electrically Driven Pumps, 19 pages; Bulletin No. 4836, The G. E. Steam Flow Meter, 16 pages; Bulletin No. 4845, Curtis Steam Turbine Generators, 16 pages; Bulletin No. 4847, Belt-Driven Alternators, Form B, 5 pages; Bulletin No. 4848, Automobile Instrument—Type DK-3, 4 pages; Bulletin No. 4850, G. E. Edison Mazda Lamps for Standard Lighting Service, 26 pages.

THE GOULDS MFG. CO., Seneca Falls, N. Y., Bulletin No. 105, Goulds Single-Stage, Single-Suction Centrifugal Pumps, 16 pages.

THE OHIO BRASS CO., Mansfield, Ohio, Supplement No. 2 to Ohio Brass Co.'s Catalogs, 91 pages.

POWER AND MINING MACHINERY CO., Milwaukee, Wis., Catalog No. 4, Rock-Crushing Machinery, 68 pages; Catalog No. 6, Roasting, Smelting, Refining, 156 pages; Catalog No. 7, Cement-Making Machinery, 86 pages; Bulletin No. 27, Improved Huntington Mills, 16 pages; Bulletin No. 28, Improved Crushing Rolls, 20 pages; Bulletin No. 29, The Evans-Waddell Chilian Mill, 14 pages; Bulletin No. 30, The "G & C" Continuous-Vacuum Filter for Cyanide Plants, 23 pages; Shaking Screens for Separating Medium Fine Material, 8 pages.

SULLIVAN MACHINERY CO., Chicago, Ill., Bulletin No. 66D, Sullivan Hammer Drills for Quarry Purposes, and Stone-Dressing Tools, 20 pages.

SERVUS RESCUE EQUIPMENT CO., Newark, N. J., Advanced Fire Fighting Equipment for Fire Departments, 8 pages; The Dreadnaught Oxygen Mine Rescue Apparatus, 8 pages.

THE TRENTON IRON CO., Trenton, N. J., Wire Rope and the Elements of Its Uses, 80 pages.

Notes on Pyrite and Marcasite

Importance of These Minerals in the Formation of Ore Bodies. Causes of Deposition

In the *Journal of the Canadian Mining Institute*, Vol. XIV, appears the following paper by E. B. Wilson.

After examining a tin-white cubical specimen of striated pyrite, curiosity led the writer to examine the books of 15 mineralogists, to find if possible the exact difference between marcasite and pyrite. While unsuccessful, nevertheless sufficient information was gleaned to emphasize three material facts, namely:

That the writers of the mineralogies were rarely original.

That they were not sure of the difference between marcasite and pyrite.

That they all agreed on iron disulphide being a common dimorphous mineral.

Thinking possibly that geologists might supply the lacking information, several standard works were examined, but beyond finding that pyrite was found in igneous, metamorphic and sedimentary rocks of all ages, nothing new was ascertained.

Chemists' and geochemists' works were next examined without obtaining any definite information, but from the various kinds of literature there was gleaned so much material that ran contrary to natural conditions, that these notes were written with the hope that they will arouse sufficient interest to start an original and substantial investigation.

Geochemists seem to have given little attention to that mineral which probably more than any other has been the medium through which the most valuable ore deposits have been formed, or if this statement is incorrect it is because they have failed utterly to record their investigations.

When a new bed of coal is discovered, almost the first thing considered is its percentage of sulphur (pyrite). Frequently coal has been condemned hastily and wrongfully on this account, the samples analyzed having included the sulphur bands. It is improbable that sulphur ever exists in coal beds in combination with the carbon of the coal, for nature has segregated and usually separated the pyrite in layers or bunches. To find sulphur in coal cleatage is unusual, and when it is so found evidences of other impurities accompany it. Charcoal, mother coal, carbonaceous shale, clay and other rock material will precipitate pyrite from sulphate solutions, but probably not coal unless high in ash, according at least to the writer's observations. Charcoal, mother coal, and shale do not contain bitumen, yet they precipitate iron disulphide from solutions, by some unknown method.

Bloxam states that "pyrite is formed from ferrous sulphate by organic matter and its presence in coal appears to be accounted for in this way." This is in direct opposition to the hypothesis, yet it is believed that if Mr. Bloxam had examined coal beds, he would have found the sulphur in slate partings or in contact with the roof or floor rock enclosing the seam; further, that it was not precipitated by the carbon of the coal. Organic matter precipitates gold from auric chloride or gold cyanide solutions; it precipitates copper pyrite from copper sulphate solutions; and blende from zinc sulphate solutions. In fact the organic matter need only be charcoal to bring about the reaction. The writer can find no evidence that coal will precipitate these minerals from solution. It seems to be more than a coincidence that pyrite is found attached to shale and rock rather than to coal.

The following formulas are advanced as possible reactions, which however the writer has not verified:

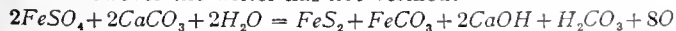

It is known that ferrous carbonate is soluble in carbonic acid and if hydrogen sulphide happened to be present the ultimate reaction might have been as follows:

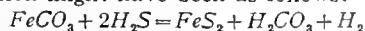

As pyrite in coal beds is in physical combination and not chemical, mechanical washing is practised to reduce the percentage of sulphur, sometimes with entire satisfaction.

The iron master maligns pyrite even more than the coal miner; in fact has no earthly use for it, yet he would be without a furnace had not pyrite furnished him hematite and limonite according to the following reactions:

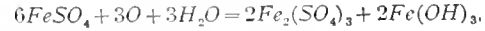
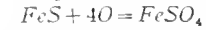
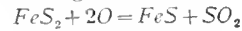

rusty quartz stain reaction.

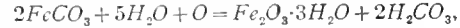
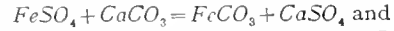

limonite reaction. In the case of a ferric salt,

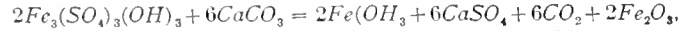

hematite reaction or if the solution was ferric chloride,



hematite reaction.

Passing to the copper matte smelter, it will be observed that he must have pyrite to produce matte; however, his case is exceptional. The lead smelter does not particularly care for pyrite if he can obtain iron oxide, but is forced to accept some of it as a rule. The zinc smelter penalizes the miner heavily if zinc ore contains more than 2 per cent. iron, which is equivalent to 4.25 per cent. pyrite, yet were it not for the weathering of pyrite the zinc smelter would have few rich oxidized ores and not so bountiful a supply of blende.

So much has been said and printed concerning the weathering of zinc-lead ores and their secondary concentration, that it is necessary in this paper to call attention merely to the relative weathering capacities. Iron has more affinity for sulphur than zinc or lead. It is therefore more easily weathered and less easily precipitated, a feature that aids in dissolving the other metal sulphides in the order given.

From the mineralogist's standpoint marcasite differs from pyrite in its color, being tin white instead of brass yellow; in its specific gravity being from 4.6 to 4.9 instead of 4.9 to 5.2, and in its crystal form being orthorhombic instead of isometric.

Pyrite like some other minerals is polymorphous, in that for some unknown reason it has more than one crystal form.

C. Mene observed some time prior to 1877 that iron disulphide of unaltered sedimentary beds is mostly marcasite, while that of metamorphic rocks is pyrite.*

Isolated crystals of pyrite are found in sedimentary rocks, and white iron pyrite is found in the metamorphic rocks in the anthracite region of Pennsylvania as well as pyrite. In Nelson County, Va., isolated cubes of white pyrite are found in aqueo-igneous rocks with striations as perfect as on brass-colored cubes. From observations, the writer is satisfied that it will require more than the dimorphism of iron disulphide to distinguish pyrite from marcasite. Stokes has noticed that much of the fibrous mineral usually called marcasite consists actually of pyrite† and the writer has seen pyramidal pyrite as brassy as any cubic pyrite.

"From the circumstances that marcasite is the characteristic form in sedimentary rocks, while pyrite occurs in plutonic rocks, Van Hise infers that marcasite is transformed into pyrite by pressure."‡ In regard to this Doctor Elsdon says: "The transition does not appear to have been realized in the laboratory and nothing is definitely known of the conditions under which it takes place."

Aqueo-igneous rocks contain isometric brassy and tin-white pyrite. This does not fully agree with Professor Van Hise's theory, although it will be noticed that the brassy colored pyrite favors quartz, particularly if copper is present. "Iron disulphide is made artificially by heating iron with an excess of sulphur or heating ferric oxide or hydrate moderately in hydrogen sulphide

* Dana's System of Mineralogy, 1877, page 800.

† Bulletin No. 186, Geological Survey, 1901.

‡ Elsdon Principles of Chemical Geology, page 111.

so long as it increase in weight." Iron disulphide made artificially for the generation of hydrogen sulphide by melting iron and sulphur, crystallizes when cooling in the isometric system, its appearance, however, does not approximate brassy pyrite, owing to the latter being formed from aqueous solutions.

Moses and Parsons in their Mineralogy state that "pyrite is being formed today by the action of hydrogen sulphide of thermal springs upon soluble iron salts. It has been developed in many rocks by the action of hot water on iron salts in the presence of decomposing organic matter." Both the above reactions are probable, although it is not necessary to have hot water; for example, "alum shale" is composed of carbonaceous matter, pyrite and clay. The pyrite when exposed to the weather will oxidize, form sulphuric acid and ferrous sulphate, that will act on the aluminum silicate and form aluminum sulphate. It is assumed that a reaction something similar to the following takes place based on the fact that silica abhors sulphur and cannot be forced into combination with it in a blast furnace.



Dr. J. V. Eldsen* in treating on "Equilibrium Conditions of Polymorphous Forms," says: "At any given temperature and pressure one of these forms is in general metastable with regard to the other, and the metastable form tends to pass spontaneously into the more stable variety. These polymorphous forms differ not only in their crystalline form and symmetry but also in their specific gravity, melting point and other physical properties. Theoretically it would be inferred that the denser forms are the more stable under high pressure." That there is a slight difference in specific gravity between the brassy and the white iron pyrites is due probably to impurities. Pure pyrite should contain 46.7 per cent. of iron, and 53.3 per cent. sulphur. Analysis of Louisa County, Va., pyrite is as follows: S 47.78, Fe 43.90, Cu 3.69, Zn 2.4, SiO₂ 1.99, As .63, P .10. H. Reis authority. An analysis of marcasite, made by C. Mene, gave Fe 38.9, S 44.9, SiO₂ 11.3, Al₂O₃ 2.4, H₂O 1.7, and CO .3. The sample came from a bituminous coal bed according to the information given, although the writer thinks it came from a slate band. In Germany, what is termed marcasite, is found in such quantities below lignite beds as to make it worth mining for sulphuric acid manufacture. In Ohio it is found near the floor of a coal bed in the forms termed sulphur balls in just the right position to break the knives out of chain coal cutters. It is difficult to reconcile the mineralogists' and geologists' statements, for if the former are right the latter are wrong, and vice versa, besides when considered collectively the statements do not always agree with natural facts. Frequently pyrite contains gold, copper, and other heavy minerals, and naturally these impurities would increase the specific gravity, and in the case of copper alter the color. Pyrite containing copper sulphide is more generally weathered than pyrite, which leads to the supposition that degree of weathering is not to be depended on as a distinguishing feature.

Summing up, it is found that none of the surmises or theories of the mineralogists, geologists and geochemists so far as pyrite is concerned are entirely tenable, and that the true difference between pyrite and marcasite, if any exist, will be found in their chemical composition. It also may be possible to tell from these analyses the amount of an impurity necessary to alter the form of a crystal from cubical to rhombic, besides obtain other data that will advance the now almost scientific study of ore deposits.

From the casual study outlined in these running comments, the deductions are:

That iron sulphide is precipitated from solutions by substances that may unite with the sulphide in sufficient quantity to change its crystal form.

That the color and specific gravity of iron sulphide deposited from solutions may be changed by the impurities entrained

during a crystallization; further that carbonaceous matter will furnish a whiter color and less specific gravity than a metallic substance.

That neither coal nor quartz alone will precipitate pyrite.

That organic matter free from bitumen, most metallic oxides, some sulphides, and some metals, will precipitate pyrite.

That marcasite and pyrite are not safely distinguished by the physical or mineralogical tests advanced.

采 采

Process Fakes and Business Men

The value of the expert practical metallurgist in protecting the otherwise shrewd business man against swindling schemes which have too often proved easily successful, is crisply set forth in a recent article by Arthur D. Little, chemical engineer, of Boston.

A curiously large number of gold bricks are gilded by chemical methods, invariably applied by amateurs, who have nevertheless utilized most ingeniously some few scraps of chemical information. The surprising thing about the industry is the character and quality of its clientele and the psychology of the selling arguments. Hard-headed business men, enriched by dearly won successes, who have learned to trust their judgment, and who have demonstrated their capacity for affairs, men who turn a box of strawberries upside down, and require a pastor's certificate of character from the office boy, these are the best prospects. They listen, they witness a demonstration, they calculate profits, and they are lost.

After all, the psychology of the transaction is not so obscure. It is because they have learned to trust their own judgment in the things they know about that they are led to regard it as equally trustworthy in case of something about which they only think they know. They have so long ignored expert assistance in their ordinary affairs that when the extraordinary occasion arises they feel quite competent to cope with it alone.

There is, too, unfortunately, still a certain atmosphere of mystery around the processes of chemistry as viewed by the average mind, which clouds deduction and seems to justify the otherwise unreasonable. "Chemistry accomplishes so many extraordinary things, why not this one which I have seen with my own eyes?"

As examples of successful "process" swindles, Mr. Little sketches briefly the Jernegan "sea-water gold" process and other fakes, including that for converting water into burning fluid.

Dangerous as these more grossly fraudulent schemes have proved to would-be investors in the past, there is often even greater danger in propositions put forward with the best intentions by half-informed inventors and promoters. While, therefore, it can be amply demonstrated that no class of investments can be counted on for larger and more regular returns than those in well-considered enterprises based on chemistry, no one untrained in metallurgy should consider such investments without expert advice.

The application of the principles of chemistry to the Bessemer process of making steel has added, directly and indirectly, according to the estimation of Abram S. Hewitt, \$2,000,000,000 yearly to the world's wealth. The ingenious adaptation of the conditions of alkali manufacture to chemical facts and principles enabled Mond & Solvay to pay 100 per cent. dividends for many years on a capitalization of \$20,000,000. In New England an original capital of \$20,000 has, through the wise development of a chemical process, grown in a decade to a surplus of \$1,000,000.

These instances are only a few of many similar ones of varying importance, but it should be borne in mind that the development of such industries requires not only knowledge of chemical science but mechanical and business matters as well.

* Principles of Chemical Geology, page 98.

Mines and Minerals

Vol. XXXII—No. 3. SCRANTON, PA.—OCTOBER, 1911—DENVER, COLO. Price, 25 Cents

PUBLISHED MONTHLY AT SCRANTON, PA.

ESTABLISHED 1881

WESTERN EDITORIAL OFFICE: 1221-1222 First Nat'l Bank Bldg, Denver, Colo.
CHICAGO OFFICE: 1006 Michigan Ave.

Entered at the Post Office at Scranton, Pa., as second-class matter

Address all business communications to MINES AND MINERALS, Scranton, Pa.
CABLE ADDRESS, "RETSOP, SCRANTON"

LONDON OFFICE: INTERNATIONAL BUILDINGS, KINGSWAY, LONDON, W.C.
SOUTH AFRICAN OFFICE: MANSION HOUSE CHAMBERS, ALDERLEY STREET, CAPE TOWN.

NEW ZEALAND OFFICE: 63 DIXON STREET, WELLINGTON.

AUSTRALASIAN OFFICE: 83 PITT STREET, SYDNEY.

SUBSCRIPTION RATES

Single Copies.....25 cents

Yearly Subscriptions, including postage:

To United States, Mexico, Cuba, Porto Rico, Hawaii, and Philippines.....\$2.00
To Canada.....2.50
To all other countries.....3.00

The date after your name on the wrapper is that of the month to which your subscription has been paid. If you do not want to continue your subscription after that time, kindly notify us.

Notice to discontinue or change of address should be sent to the Scranton office.

When notifying us of a change of address always give your FORMER as well as your present address.

Removal of Western Office

THE Denver office of MINES AND MINERALS, which for some years has been in the Equitable Building, has been removed to pleasant and commodious rooms 1221-1222 First National Bank Building. Mr. Geo. F. Duck, western editor, extends a cordial invitation to all mining men to make this office their headquarters when visiting Denver.

來 來

Postponement of the American Mining Congress Meeting

THE fourteenth annual session of the American Mining Congress, which had been arranged to be held at the La Salle Hotel, Chicago, on September 26 to September 29, has been postponed until October 24 to October 28, inclusive. The postponed meeting will be held at the La Salle Hotel according to the original arrangements.

The postponement was ordered by the committee that President Taft might attend and address the convention on his return trip from the West.

During the five days of the meeting MINES AND MINERALS will have an office in Room 1845, La Salle Hotel, near the headquarters of the Secretary of the Congress. Members of the Congress and visitors are cordially invited to make this room their headquarters during the session. Mail addressed to members in care of MINES AND MINERALS will be looked after and promptly delivered.

來 來

The Calumet and Hecla Consolidation

IT IS interesting to note that the valuation placed on certain Michigan copper mines by J. R. Finlay is 34.7 per cent. less than the appraisements made by the engineer of the Calumet and Hecla on those properties included in the proposed consolidation. The opposition comes from some of the stockholders of the smaller companies who imagine the consolidation is a scheme to increase the declining values of the Calumet and Hecla at their expense. They appear blind to the objects of the consolidation, are unable to appreciate that the men most largely interested in the smaller companies are the ones to propose the consolidation; nor are they able to believe that high financeering is not the purpose in view. Mr. Finlay's report shows that the Calumet and Hecla directors are exceedingly liberal in their valuations, but if it did not, the history of the former management and the fact that the present officers are the sons of their fathers counts for much, for as the twig is bent so is the tree inclined.

TABLE OF CONTENTS

EDITORIAL—	
Removal of Western Office—Postponement of the American Mining Congress—The Calumet & Hecla Consolidation—Michigan Mine Valuation—The Election of State Mine Inspectors.....	129
COAL MINING AND PREPARATION	
UNIVERSAL MINE PLANT AND SHAFTS, by A. F. Allard.....	131
MECHANICAL LABORATORY SAMPLER.....	139
THE PURITAN MINE, by Joseph Watson.....	140
SAFETY BLOCKS AT CASTLE GATE TIPPLE.....	141
WASTE HEAT COKE OVENS.....	142
BOOK REVIEW.....	144
TRADE NOTICES.....	145
ANNUAL FIRST-AID CONTESTS.....	146
NATIONAL FIRST-AID FIELD DAY.....	147
COAL MINING IN MICHIGAN.....	148
CATALOGS RECEIVED.....	151
OBITUARY—	
Francis L. Robbins.....	151
CONSERVATION OF MINERALS, by Dr. Henry S. Drinker.....	152
UNDERGROUND SAFETY APPLIANCES, by Stephen L. Goodale.....	155
PLAN TO GET MORE LARGE COAL.....	158
ROCK DUMP (Cameron Mine).....	158
CORRESPONDENCE—	
Oscillating Screens and Concrete Construction—Early Watering of Mines and Employment of Shot Firers—Early Shot Firers—Coal-Dust Explosions—Watering Dust in Utah.....	159
BOOKS RECEIVED.....	160
EXAMINATIONS—	
Utah Mine Foremen's, and Illinois Selected Questions.....	161
ORE MINING AND METALLURGY	
PIOCHE, NEVADA, DISTRICT, by R. M. Bell.....	163
METHOD OF SMELTING WITH OIL.....	165
SUPPORTS FOR FEED WIRES.....	166
SURVEYING AND SAMPLING DRILL HOLES, by E. E. White.....	167
ORE MINE INSPECTION IN MISSOURI, by L. L. Wittich.....	173
NOTES ON CHILIAN MILLS IN RUSSIA, by H. C. Bayldon.....	177
RELATION OF FORESTRY TO MINING, by J. F. Lawson.....	180
HIMALAYA TOURMALINE MINE, by John Cowan.....	181
GENERAL ORE MINING NOTES.....	182
FOREST OF DEAN MINE.....	184
AN ORE MINE TROMP.....	185
COPPER SMELTING FURNACES, by Chas. C. Christiansen.....	186
JOPLIN ZINC NOTES.....	187
CALCULATIONS IN ORE CONCENTRATION, by Rudolph Gahl.....	188
LAKE SUPERIOR MINING INSTITUTE MEETING.....	191
PERSONALS.....	191
SQUIBS—	
Petroleum in Ontario, 141—Raise Goats on Coal Lands, 154—Scientific Coal Mining, 162—Cobalt Ores, 176—Radium Minerals in Australia, 179—Duralumin.....	185

Michigan Mine Valuations

FARMERS in Michigan believing that they were unjustly burdened with taxes while mines and manufacturing enterprises were lightly assessed, demanded that an expert should be hired to place a valuation on the ore mines in the upper peninsula.

J. R. Finlay, who was engaged by the state for this purpose, rendered his report in August. In the report, stock valuations are ignored as speculative, appraisements being based on ore in sight. After making suitable deductions for mining, milling, smelting, refining, and transportation the value of the copper mines on Keweenaw peninsula was placed at \$69,815,000.

The estimated value of the iron-ore mines is \$119,485,000, a figure so startling to the iron-ore operators they are undecided whether they belong in the humble or the proud and haughty class. Before just taxation can be based on such a mighty valuation large deductions must be made from its face value; for instance, the changes in the grade of ore in the mines reduce its value, fluctuation in market conditions affects its price and the increasing cost of supplies and labor, the deterioration of the plant, the expensive improvements that must be installed to compete with other iron mining states more favorably situated, are factors which Mr. Finlay could not anticipate in making his estimate.

Michigan citizens should consider the number of tradesmen and others dependent on the mines and the importance of the mines of their state relative to its common prosperity; also they should remember that Wisconsin and Minnesota are iron-ore producing states which are sharp competitors.

來 來

The Election of State Mine Inspectors

SOME years ago, when the bill providing for the election of state mine inspectors for the anthracite regions was before the legislature of Pennsylvania, this journal strenuously opposed it as a piece of mischievous legislation detrimental to the best interests of both mine operators and miners.

It is just as much opposed to the system now as it was then, and in view of efforts being made to make the position an elective office in other states, we deem it wise at this time to again express our views in the hope that no other state will make the same blunder as did Pennsylvania.

In the first place the position of mine inspector should be a non-partisan one. The sole qualification should be technical ability coupled with high moral character and that element sometimes called diplomacy, or tact, but generally known as common sense.

While the law in Pennsylvania provides that all candidates for inspectorships in the anthracite regions must have successfully passed an examination before a board of examiners appointed by the several courts before they can have their names placed on the ballots, this does not take away the necessity of a political

campaign with its accompanying evils and the payment of campaign expenses out of a possible salary already too meager to ensure the state holding a good man permanently.

As the privilege of voting for a state mine inspector cannot legally be restricted, the successful man may be the choice of farmers, merchants, saloon keepers and other classes in no way directly interested in mining, and therefore absolutely unqualified to judge as to the qualifications of the candidate.

In fact in many election districts if there were two candidates for a vacancy and one through superior fitness for the office had the support of a large majority of the mine officials and mine workers, an inferior man, through political influence and possibly by unfair and illegal methods, might be elected. Again in a strong Republican district the best qualified man might be a Democrat and as a result he would be defeated, or *vice versa* in a strong Democratic district the same fate would await an able Republican.

That such instances have not so far actually been the case in the anthracite regions of Pennsylvania has been due to the fact that the number of men certified by the examining boards as being qualified for the position has been practically limited to the number of vacancies to be filled.

There is only one way in which to secure the best type of men as state mine inspectors. That is to have an examining board, appointed by the governor or the court, composed of equal numbers of mine owners or mine superintendents and intelligent miners with a competent mining engineer as the odd member of the board. This board of examiners should be sworn to hold a fair and honest examination and report the actual results to the appointing power. The report should cover not only the technical qualifications of the candidates, but should also cover their general fitness based on their answers to carefully considered questions calculated to draw out their ability to carry out the provisions of the mine law with least possible friction. The matter of the candidate's politics, nativity, or religious belief should have no influence on the standing given him by the examining board. Then the governor should be required by law to issue a commission to the man who passed the examination with greatest credit regardless of his political affiliations. In this manner and with sufficient salary to make the office worth as much or more than a mining corporation will pay for the services of a man of like ability, competent men can be secured. Mere technical ability and good character is not enough to make a man a good mine inspector. The writer was personally acquainted, some years ago, with an inspector of most commendable moral character and exceptionally well qualified for the position in a technical way, but he was a failure as an inspector, owing to his irascible temper, which had him almost continually at odds with both the mine officials and the miners in his district.

COAL MINING AND PREPARATION

Universal Mine Plant and Shafts

Modern Twin Collieries, Concrete-Lined Shafts and Permanent Structures of the Bunsen Coal Co., Near Clinton, Ind.

*By A. F. Allard**

Universal plant of the Bunsen Coal Co., of Westville, Ill., a subsidiary of the United States Steel Corporation, is situated in Vermilion County, Ind., 5 miles southwest of Clinton, Ind., and is reached by a branch track extending $2\frac{1}{2}$ miles, connecting with the C. & E. I. Railroad. In the choice of a location for this plant, which is situated in a broad valley with an unexcelled

on under the general direction of Clay F. Lynch, general superintendent of the Bunsen Coal Co., and the construction engineer of the company who was in charge of the field work. The two steel tipples and head-frames, one for each hoisting shaft, were erected by the Illinois Steel Co., and the contract for the mine buildings was awarded to the Nicola Building Co., of Pittsburg, Pa. The latter are all constructed of reinforced concrete, including the floors and roofs of buildings. The window frames and sash are all of steel, fitted with pivoted ventilators, making the buildings absolutely fireproof. Fig. 1 is a view of the twin tipples and head-frames before covering.

Departing from the ordinary procedure of lining coal-mine shafts with timber, the Bunsen Coal Co. have made their own

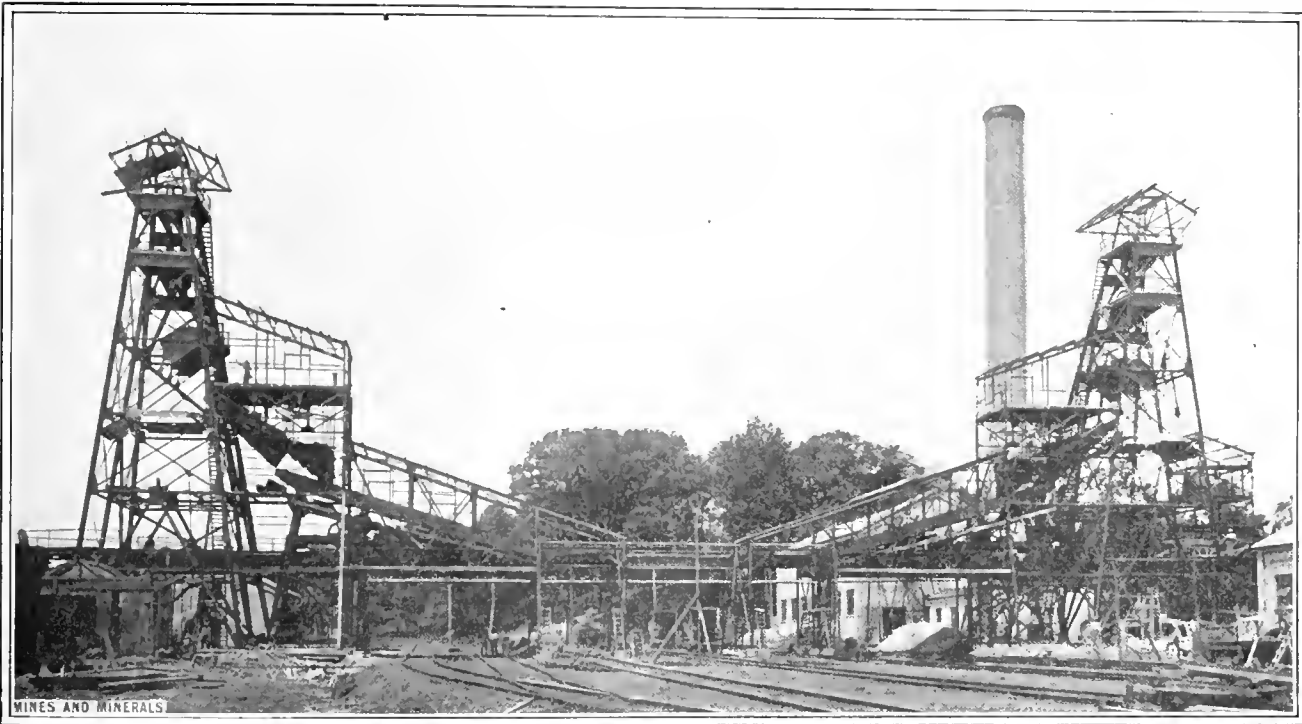

FIG. 1. TWIN TIPPLES BEFORE COVERING, UNIVERSAL MINE

position, careful consideration was given to every detail connected therewith. Many new features for a coal-mining plant were added and the most modern methods of construction and installation were adopted to make this plant absolutely fireproof and structures permanent; also the knowledge gained from many years' experience has been applied perfecting it, so that it stands today without a rival. The appropriate name of "Universal" is taken from the Universal Portland Cement Co., which brand of cement was used exclusively for all of the concrete work, and every pound of material used in the construction of this plant was made by some of the subsidiary companies of the United States Steel Corporation. The combined mines, comprising the No. 4 and No. 5 coal seams, will have an output of 3,300 tons of coal per day.

The complete plant above ground was designed by and built under the supervision of the Roberts & Schaefer Company, consulting engineers of Chicago. All of the improvements, including the mining plant, sinking of shafts, etc., were carried

designs and have used concrete for this purpose throughout the entire depth of the two main hoisting shafts and ventilating shaft. These shafts are the first of their kind and size to be successfully sunk in the Indiana coal fields. Two circular-end design concrete-lined hoisting shafts were sunk at a distance of 190 feet apart. The ventilating shaft is located 400 feet from the No. 5 hoisting shaft.

The shaft contract was awarded to Walter F. Patterson, of Pittsburg, Pa. Ground was broken for the No. 4 hoisting shaft October 24, 1910, for the No. 5 hoisting shaft on December 14 of the same year, and for the ventilating shaft on February 11, 1911.

The No. 4 and No. 5 hoisting shafts are the same size, of circular-end design, with rectangular side walls, and measure 21 feet 10 inches long by 10 feet 10 inches wide in the clear on the center lines of the axes. The No. 4 shaft has a depth of 228 feet and the No. 5 shaft a depth of 131 feet below the top of coping to the bottom of the No. 4 and No. 5 coal seams.

Each shaft is provided with a sump 10 feet in depth below the cage landing. The shafts are divided into four compart-

* Construction Engineer, H. C. Frick Coke Co.

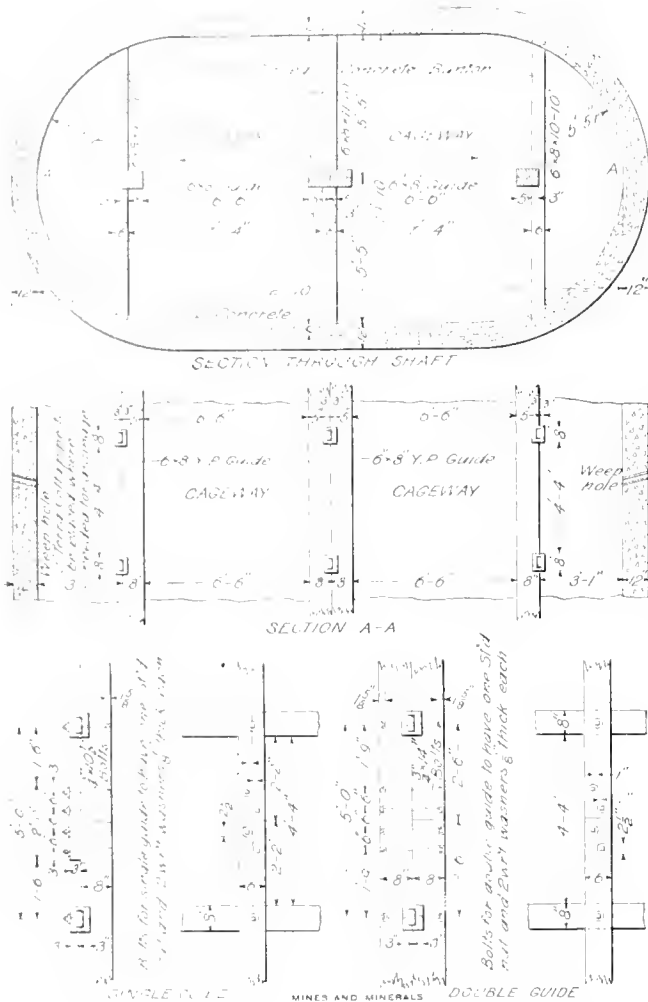

FIG. 2. SECTION, ELEVATION AND DETAILS OF SHAFT LINING

ments, containing two cageways and two pipeways. The circumference of the inside of the concrete lining is 56 feet, with a clear opening area of 211 square feet, comprising 168 square feet for the two cageways and 43 square feet for the two pipeways. The ends of the shafts conform to a radius of 5 feet 5 inches. The shaft buntons are 6" x 8" concrete, reinforced with 6-inch steel channels, spaced 5 feet center to center. The cage guides are 6" x 8" yellow pine and are bolted to each of the concrete buntons. Fig. 2 shows a section and elevation of the shaft lining and fastening of the guides to the concrete buntons.

The ventilating shaft, of circular-end design with rectangular side walls, provides for a separate airway and stair compartment leading to each of the No. 4 and No. 5 coal seams. The section leading to the No. 5 or upper seam measures 31 ft. 2 in. x 11 ft. 4 in. in the clear on the center lines of the axes. This section has a depth of 171.5 feet below the top of coping to the bottom of the No. 5 coal bed, and is divided into four compartments, containing two airways and two stairways. The circumference of the inside of the concrete lining is 75.3 feet, with a clear opening area of 325 square feet, comprising 83 square feet for airway to the No. 5 seam, 98 square feet for the airway to the No. 4 seam, and 111 square feet for the two stair compartments. The airway for the upper seam is 7 ft. 4 in. x 11 ft. 4 in. and for the lower seam 8 ft. 8 in. x 11 ft. 4 in. in the clear. The ends of the shaft conform to a radius of 5 feet 8 inches. After leaving the upper seam the single airway and stairway is carried down to the lower seam; this section measures 17 ft. x 11 ft. 4 in. in the clear on the center lines of the axes, and has a depth of 100 feet from the bottom of the No. 5 seam to the bottom of the No. 4 seam. The depth from top of coping to the bottom

of the lower seam is 271.5 feet. The circumference of the inside of the concrete lining is 47 feet, with a clear opening of 165 square feet. The two main airways are separated by a 12-inch reinforced partition wall, which extends from the top coping to the bottom of the upper seam. The stairways are separated from the air compartments with a 5-inch reinforced concrete curtain wall. This wall is tied in and supported by 6" x 8" concrete buntons reinforced with 6-inch channels, spaced 5 feet center to center. These buntons also stiffen the concrete side walls of the shaft and support the beams which carry the steel stairs. Fig. 3 shows a section and elevation of the shaft lining and the division of compartments. Fig. 4 shows the design of the steel stairway leading to each seam in the ventilating shaft.

Steel Shoes.—The steel shoes used for the sinking of the No. 4 and No. 5 hoisting shafts, from the surface of ground to the solid strata, were of rectangular design forming an open caisson, and measured, when set up ready for sinking, 17 ft. 6 in. x 26 ft. 6 in. The side and end plates are 1/2 inch thick. The corners were all stiffened with 6" x 6" x 1/4" angles. The angle for supporting the 12" x 12" jacking timber was riveted to the side and end plates and extended around the entire shoe on the inner side; these angles were also 6 in. x 6 in. x 1/4 in., the top flange being 14 inches from the bottom of plate or the cutting edge of shoe. The shoes used for both shafts were of the same size with the exception of the height; at the No. 4 shaft this was 6 feet while at the No. 5 shaft an 8-foot shoe was used.

The jacking timber was bolted to the side and end plates of the shoe with 1-inch bolts, spaced alternately 11 inches apart. At each corner and under the timber 3/4" x 6" plates for stiffening the corners were riveted to the main angles. The shoe when completed for the No. 4 shaft weighed 12,000 pounds and for the No. 5 shaft 17,800 pounds.

The steel shoe used for the sinking of the ventilating shaft was designed to conform to the shape of the concrete lining 24 inches thick. The plates were 1/2 inch in thickness, having a vertical depth on the back line of lining 26 inches, and run

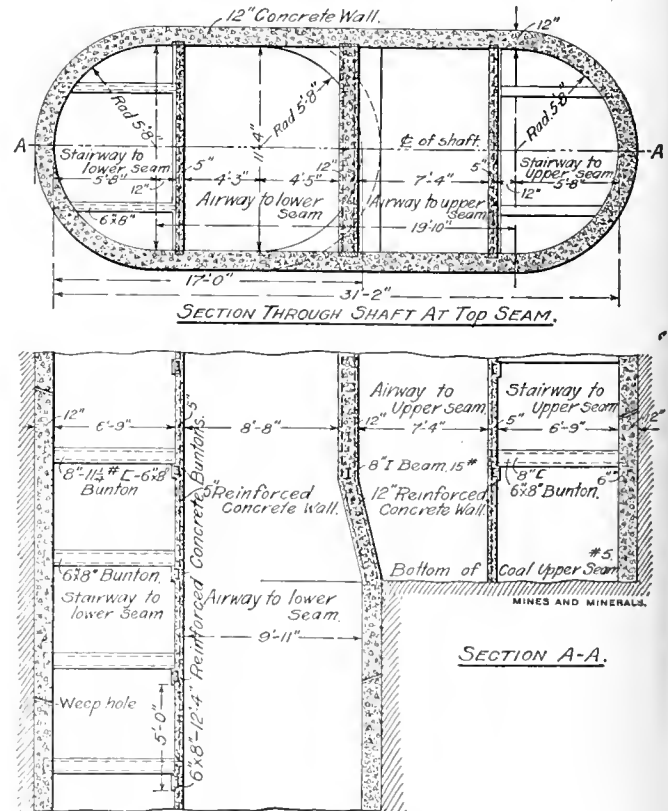

FIG. 3. SECTION AND ELEVATION OF SHAFT LINING

on an angle of 45 degrees from cutting edge to the inner side of lining. The side pieces are 19 feet 10 inches long and seven sections with splice-bar connections formed the end circles. The first section of concrete poured filled the inside of shoe, which was fastened to the lining wall with $\frac{1}{4}$ " x $2\frac{1}{2}$ " bonding bars spaced 18 inches apart around the entire shoe; these bars were bolted fast to the cutting edge. At the top, to prevent buckling, $\frac{3}{4}$ -inch bolts spaced every 3 feet were bolted to the plates and through the concrete. This shoe had a total weight of 11,500 pounds. Fig. 5 shows the design of steel shoe used at the hoisting shafts and Fig. 6 the design of steel shoe used at the ventilating shaft.

Wooden Forms.—Wooden forms were used for all of the concrete-lining work at the three shafts. At the two hoisting shafts the inside form only was necessary, the concrete filling into the sides of the rock excavation. At the ventilating shaft both inside and outside forms were used until the concrete caisson at this shaft was anchored to the solid. The forms were generally made in six units, the two circular ends and two units for each side; these when bolted together formed the complete section around the entire shaft and measured 5 feet in height. The lagging was $1\frac{1}{2}$ " x 6" tongued-and-grooved yellow pine, stiffened on the sides, in center and at top and bottom with $1\frac{1}{2}$ " x 6" chord pieces. The segments for the circular ends were cut from $1\frac{1}{2}$ " x 12" boards. The entire form in position was braced with three rows of 4" x 6" cross-pieces, placed at top and bottom of each form and bolted to the framework. Before concreting the

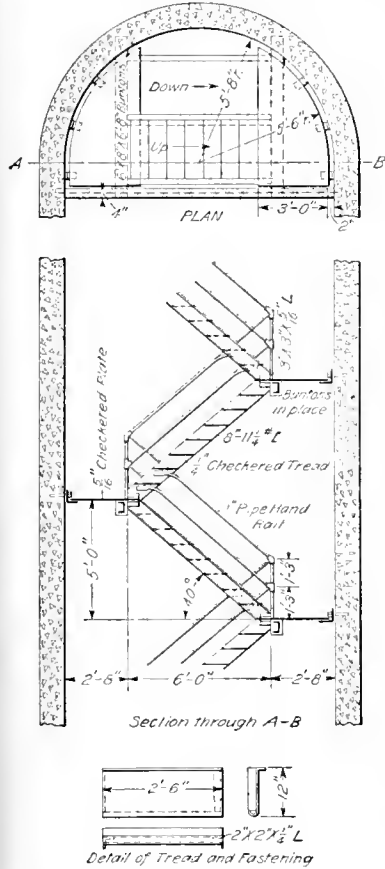

FIG. 4. STEEL STAIRWAY IN SHAFT

surface of the lagging next to the concrete, the surface was given a coat of oil, permitting the forms to be easily released after the concrete was set. Fig. 7 shows the end view of the forms set to place, ready for the pouring of the concrete.

Sinking and Concreting.—The same method of sinking and concreting was adopted for both No. 4 and No. 5 hoisting shafts; namely, for sinking, the use of a steel shoe for guiding the curbing timber through the soft strata. The shoe was forced through this material by screw jacks placed around the jacking timber and using the weight of the curbing timber to jack against and sink the shoe. Each $2\frac{1}{2}$ -inch jack used had a capacity of 10 tons. At times as many as 30

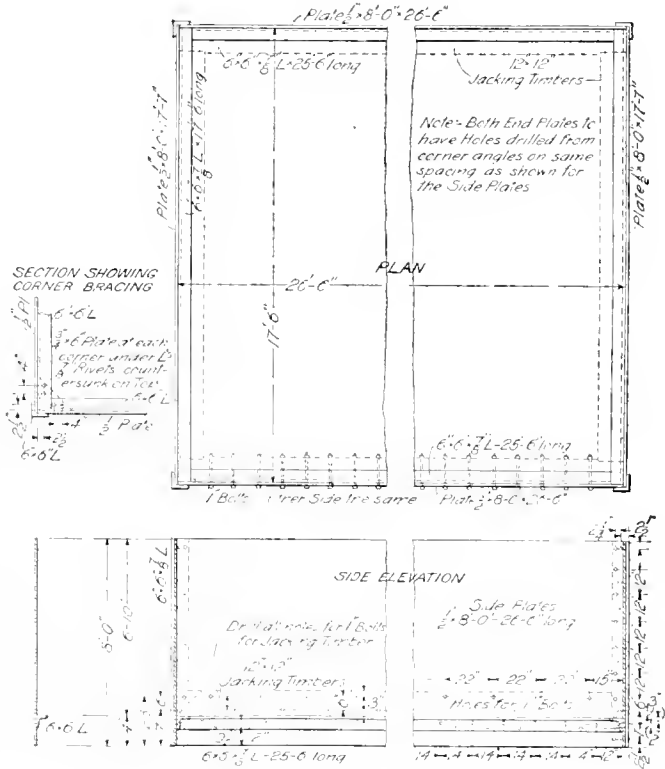

FIG. 5. STEEL SHOE USED AT HOISTING SHAFTS

were in use. The shoe at the No. 4 shaft was sunk and landed at a depth of 42.5 feet below the top coping and anchored in the blue drift. Mattocks were then used to chop out the stiff clay, and, as excavation was made, 8" x 10" skin timber was placed and carried down 40 feet below the shoe. At a distance of 68 feet from top of shaft, and after going through the 30 feet of blue drift, sand and gravel heavily charged with water were encountered for a depth of 18 feet. The pressure at this point made it impossible for the men to place the last $3\frac{1}{2}$ feet of skin timber before reaching the hard cemented gravel. Three-inch sheet piling in 5-foot lengths was then used to close up the gap, and driven to the solid with sharpened points. The upper ends of the piling were well spiked to the timber lining. On account of not being able to penetrate the hard gravel with the piling, the heavy pressure from sand and water began to exert itself at the bottom of the piling, making it necessary to place the first section of concrete shaft lining without delay. A base for supporting the first section of concrete was cut out around the entire shaft to a width of 30 inches and the entire space between the clearance line of shaft and face of timbering was filled with concrete to a vertical depth of 5 feet. From this point to the top of coping the concrete lining was placed with an average thickness of 27 inches on each side and 18 inches thick at the circular end of the shaft.

To save concrete yardage at the four shaft corners, 6" x 8" diagonal pieces spaced every 5 feet were placed and covered with 1-inch tongued-and-grooved boards. These were placed in advance of the concreting and the corners filled in with sand as the lining advanced. Before concreting was

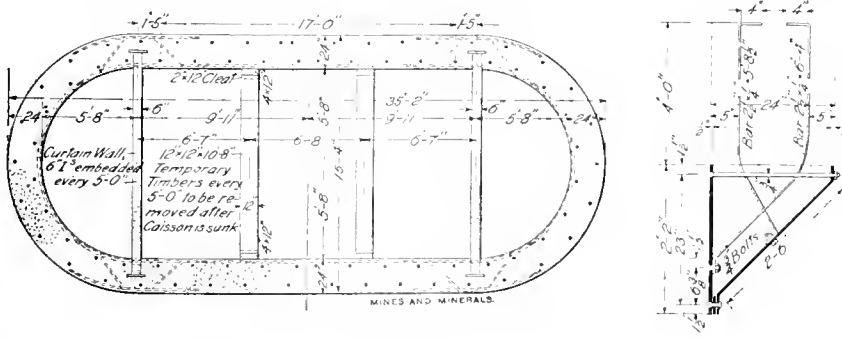

FIG. 6. STEEL SHOE USED AT VENTILATING SHAFT

started at each of the hoisting shafts, the first excavation was made to a depth of 90 feet below the surface of the ground. All excavating was done to the full measurements of the outside perimeter of the timber, and of the concrete lining where timber was not used in solid ground. The excavation was kept to a correct line by plumb lobs suspended from a template placed above the opening. Derricks were used at each shaft for a depth excavated of 90 feet below the surface, when wooden head-frames replaced these for the completion of the shafts. The method of placing the wooden forms and concrete was the same for each shaft; namely, at a point some 5 feet above the bottom of the excavated portion of the shaft a wide supporting base was made, usually 30 inches wide, extending around the entire shaft, this base supporting the several sections of concrete lining immediately above without the use of hitch timbers or other temporary planking. The forms were lowered in sections, nailed and bolted in position at the bottom and brought to the proper lines of the shaft. The concrete was then mixed in a cubical mixer located at the top of shaft, poured into bucket, lowered and the mix distributed in the form by means of a movable chute supported on a temporary platform at the top of each form section.

The concrete buntons were placed in their respective openings as the concrete lining advanced and were carefully fastened

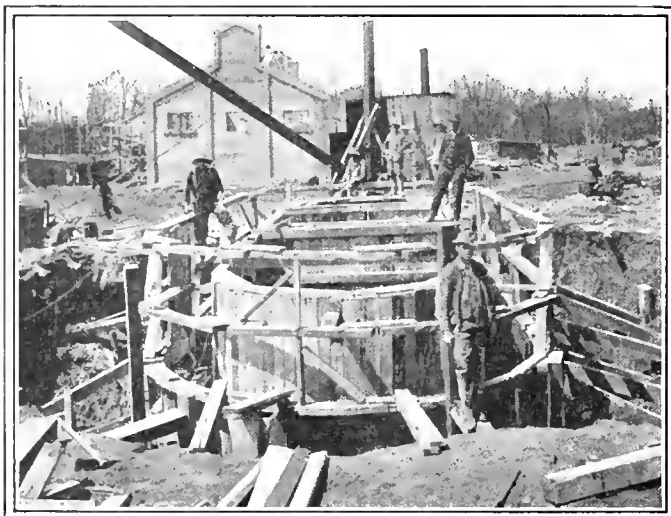

FIG. 7. FORMS IN PLACE AT VENTILATING SHAFT

on the correct center lines and poured together with the concrete walls; however, at the No. 5 shaft the buntons were made and poured on the surface, the ends being concreted in with the wall sections when the latter were being concreted. After the first form was completely filled another form was immediately placed above and bolted fast to the previous section, and the correcting operation continued until the entire excavation was closed in. Four complete form sections, or 20 vertical feet, were usually poured before the removal of the bottom form. No forms were removed until the concrete had set at least 24 hours.

Progress and Method of Sinking the Ventilating Shaft.—The method adopted for the sinking of the concrete caisson of the size and design at this shaft was entirely new for coal-mining purposes. The inside dimensions are 31 ft. 2 in. \times 11 ft. 4 in. with a clear opening area of 325 square feet. The concrete lining wall is 24 inches thick for a depth of 96 feet below top of coping and has a surface area of 163 square feet, or 6 cubic yards of concrete per vertical foot of shaft, each vertical foot weighing 12 tons. The entire section was sunk by the weight of the concrete to a depth of 84 feet below the top of coping, through sand and gravel strata, at which point the steel shoe and shaft walls were landed on the solid rock. The total weight sunk to this point was 1,000 tons. The first excavation was

made with derrick to a depth of 10 feet below the surface. The wooden form sections for this depth were then placed in position and filled with concrete. As the weight of the concrete placed settled the shoe, excavation was made on the inside to permit of another 5-foot section of concrete to be placed on the top, and the operation repeated until the solid rock was reached. At times the side pressure was so great that the concrete walls would not readily sink, when by flooding the outside with water the friction was lessened and the lining walls settled. To tie together each 5-foot section of lining wall, 1" \times 4' round steel bars were used, in bent form, spaced 2 feet apart around the entire section and gripped 2 feet into each section. It often happened that one end of the shaft settled more than the other, when mucking at the lower end had to be stopped and continued at the high end until both came to the same level; however, when the shoe was landed the entire shaft was found to be close to the plumb lines. The advantage of sinking by this method, through soft ground, over that of using curbing timber and jacking the shoe down by hand was not only in the progress made, of 35 feet per month at this shaft as compared with 25 feet per month made at the No. 4 and No. 5 hoisting shafts, but also the saving in cost by eliminating all timber and pouring the concrete and erecting the forms on the surface. Fig. 8 shows this shaft, with the concrete walls exposed above the surface before settlement. When the picture was taken, 60 feet of concrete lining was placed. This shaft is undoubtedly the largest concrete caisson ever sunk in this country, by this method, for coal-mining purposes.

Curtain Walls in Ventilating Shaft.—These walls divide the stairways from the air compartments leading to each of the upper and lower coal seams. They are 5 inches thick extending the entire width of the shaft and continuous between buntons from top to bottom. The wall was poured in panel sections between the concrete buntons. The reinforcement consisted of American Steel and Wire Co.'s No. 4 triangular mesh, which was attached to $\frac{3}{4}$ -inch steel frames which were set in position between the two wooden forms, and the entire panel section of wall concreted. The concrete used was composed of one part cement to four parts of screened gravel. To obtain a good bond between the curtain wall and the shaft lining walls, 3" \times 4" strips were carried in the shaft lining and removed when the different panel sections of curtain wall were being poured, making the compartment perfectly air-tight. No work was done on the curtain walls until the shaft lining was completed. Fig. 10 shows the steel frame which supports the reinforcement.

Waterproofing Shaft Lining.—Waterproofing in the No. 4 hoisting shaft was started at the temporary water ring, 41½ feet below the top of the coping, and the following method was used: Strips of 2" \times 6" plank laid vertical and spaced 2 feet apart in the clear were spiked to the inside face of the 8" \times 10" curbing timber. The strips were carried up to a point 6 feet below the top of coping. For a distance of 8 feet above the water ring and where the water pressure was the greatest a double layer of 1" \times 4" tongued-and-grooved flooring boards were used. These were nailed horizontally to the 2" \times 6" strips. All water running between the skin timber was then conveyed back of this lining and between the intervening spaces of stripping into the water ring. For conveying the water from the ring through the concrete shaft lining four 4-inch pipe bleeders were placed. After the concrete had thoroughly set these bleeders were screw capped and all water entering the shaft was shut off. From a point 8 feet above water ring to the surface, a single layer of flooring boards was sufficient. All boards were primed and given a coat of waterproof paint, this work being done on the surface. After the lining boards were in place a coat of hot asphalt was applied in sections over the entire surface. A layer of Johns-Manville asbestos, waterproof, four-ply fiber was placed; the fiber was applied against the hot asphalt, adhering same to the lining without nailing. Each section of fiber was laid with a 3-inch lap. After the fiber was placed

a second coat of asphalt was applied to the paper, and this in turn given a coat of heavy waterproofing compound of "Leak-No" brand, placed just ahead of the 5-foot sections of concrete lining when being poured.

At the No. 5 hoisting shaft the waterproofing was carried down to a distance of 85½ feet below the top of the coping. The only difference in method used at this shaft was that 1"×4" strips were used back of the lining and these were laid diagonally on a 30-degree pitch and spaced 12 inches apart in the clear. These strips ran from the center line of the shaft to each of the four corner pockets; the water was then conveyed to the ring. The tongued-and-grooved lining in this shaft was all laid vertically and only one layer used throughout. However, the method adopted in each shaft proved satisfactory and made each shaft absolutely watertight. Fig. 9 shows the view at the top of the shaft looking at the waterproofed lining before the concrete walls were placed. Fig. 11 shows the method of placing waterproofed lining.

Materials Used in Permanent Work.—All concrete for lining the shafts is composed of one part Universal Portland cement to five parts of Wabash River gravel. The reinforced concrete buntons and partition walls are composed of one part cement, two parts sand and four parts of screened gravel. No crushed stone was used in any of the concrete work. Cement for the entire work was of "Universal Brand," manufactured by the Universal Portland Cement Co., of Chicago, Ill. Frequent tests and analyses were made by this company of the gravel used in the work, from samples submitted from time to time during the progress of work, to determine the percentage of silt and voids. From this material concrete briquets were made and tested for tensile and compressive strengths. The only timber used in the three shafts were the 6"×8" yellow-pine cage guides in the No. 4 and No. 5 hoisting shafts.

Progress of Hoisting Shafts.—From an inspection of the weekly progress, the bottom of the 5-foot coal bed was reached April 14, 1911, in the No. 4 shaft at a distance of 235 feet below the top of the coping. The bottom of the 5-foot coal bed was reached May 26, 1911, in the No. 5 shaft at a distance of 131 feet below the top of coping. The time to complete the sinking and placing of the concrete lining covered a period of 26 weeks in the No. 4 shaft, and 22 weeks in the No. 5 shaft, from the start of the work of excavating, showing a progress of 10 feet per month in the No. 4 shaft and 30 feet per month in the No. 5 shaft, for the completed work. The progress shown was very fair considering the bad ground and the extra work of jacking the steel shoe a distance of 42.5 feet in the No. 4 shaft and 85.5 feet in the No. 5 shaft through the sand and gravel strata, placing the heavy curbing timbers and handling the water, which amounted to about 400 gallons per minute in each shaft.

Bottom Arches and Landings.—At the bottom of each hoisting shaft the approaches leading to the cage landing on both the loaded and empty sides are of concrete. The arches have a clear span of 17 feet 4 inches and have a minimum thickness of 24 inches for the side walls and crown. These arches extend a distance of 12 feet from the face of shaft lining. On the empty side the extension for 22 feet has a clear span of 17 feet 4 inches and accommodates the automatic car lift installed; from this point for a distance of 56 feet to the switch for empty-car run-around, the span is 9 feet in clear. The roof in both of these sections is protected with 15-inch I beams weighing 42 pounds to the foot and spaced every 4 feet, center to center. These are supported by the concrete side walls and covered with 4-inch reinforced concrete slabs. Arches of an 8-foot span, having a minimum thickness of 18 inches, extend a distance of 12 feet from both ends of the shaft lining, and connect with the cross-entries and manway around the shaft bottom. An archway of 4-foot span is placed in the side walls for entrance to the manway. At the intersection of all arches with the concrete walls in the shaft lining, steel bars were placed for reinforcement. The extension on the loaded side has a clear span of 11 feet

6 inches for a single-track bottom, which gives ample room for the men to work on each side and is extended for a 40-wagon storage at the bottom. The extension is of 6-inch concrete side walls and 8-inch concrete block arch which rests on the side walls at the spring line of the arch. These blocks were all made on the surface in steel forms, and joints broken on the radial center lines. The blocks were placed in position in the entry as the excavation advanced, each block being cement plastered into place from each of the side walls until the keystone was placed, perfecting the arch ring. This method of construction eliminated all forms and arch centers, also the pouring of concrete in the entry. The concrete blocks for this work were all made on the surface and molded in steel forms. Fig. 12 shows the concrete arches at the bottom landing and Fig. 13 shows the reinforced concrete slabwork and section of heading where concrete side walls support the I beams for roof protection on the empty sides. Fig. 14 shows the design of steel form for making the concrete block arch of 17-foot 4-inch span and used on the loaded sides approaching the cage landings at the bottom of each hoisting shaft.

Mine Drainage.—The mine drainage will be taken care of by the installation of one single, horizontal, direct-acting, simple type, 20"×10"×30" mine pump located near the bottom



FIG. 5. VENTILATING SHAFT, CONCRETE IN PLACE BEFORE SETTLING

of the No. 4 hoisting shaft and a 12"×7"×12" pump, of same pattern, will handle the water met with at the No. 5 hoisting shaft.

Mine Tracks, Etc.—The main haulage roads will be laid up with 40-pound steel rails and the room entries with 16-pound steel. The gauge of track is 42 inches. Experiment, at this mine, will be made with portable track and steel mine ties, manufactured by the Carnegie Steel Co., both on the main haulage roads and room entries. Portable track switches, with steel mine ties, will also be installed. At the bottom of each hoisting shaft, on the empty side, there will be placed a Robert Holmes single automatic car lift, operated by steam, for the transfer of empty mine wagons from the cage to the empty-car run-around. For the mine haulage, Jeffrey 6-ton, 250-volt, electric mine locomotives, with single-end control, will be used for each coal seam. Both the Jeffrey and Sullivan, 250-volt, electric chain coal-mining machines will be used for the cutting of coal.

Permanent Equipment.—The boiler house, located near the No. 5 hoisting shaft, is 47 ft. 4 in.×71 ft., and contains four class "S" Stirling water-tube boilers set in two batteries, each boiler rated at 374 horsepower, operating under a pressure of 125 pounds per square inch. Room is reserved for the future addition of two more boilers, should the same become necessary.

Playford improved chain grate stokers are installed at each boiler, the stokers being operated by an 8"×10" vertical steam engine. A special No. 5, two-section, horizontal, Stilwell feed-water heater and purifier, open type, suitable for heating 12,000 gallons of water from 50 to 210 degrees, supplies the feedwater for boiler use. The water is delivered by two 12"×7"×10" Worthington horizontal duplex feed pumps.

The boiler ashes are conveyed in steel buckets which are mounted on wheels and run the entire length of the boiler house, on rails, in an enclosed concrete-lined tunnel, which is 5 feet 6 inches wide by 7 feet 9 inches high. The ashes are run to the end of tunnel, and, for their conveyance to the field dump a steel structure is provided and extends a distance of 400 feet from the boiler house. This will carry an electric hoist with motor-driven trolley, having a capacity of 1½ tons and an available lift of 45 feet, with a lift speed of 40 feet per minute, operated by a 6-horsepower motor and a trolley travel with a speed of 250 feet per minute with a 4-horsepower motor.

A reinforced concrete coal bunker for the storage of boiler coal is erected inside of the boiler house, having a capacity of 250 tons. The bunker is divided into six panels, 14 feet center to center, and is 84 feet in length. The entire body is hung and supported by reinforced concrete columns. The bunker

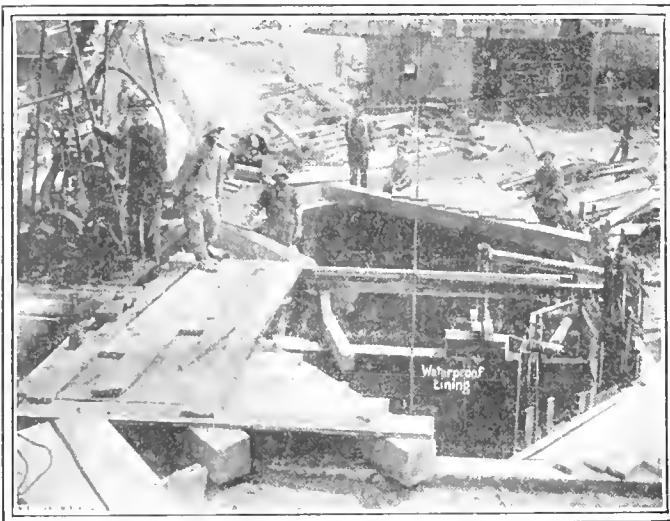

FIG. 9. WATERPROOF SHAFT LINING

top is 15 feet in width and has a depth of 9 feet 7½ inches with circular-shaped bottom, which hangs with a clearance of 16 feet 8 inches from the floor. Twelve steel outlets for feeding coal to the boilers are provided in the bottom; each of these connect to 12-inch diameter gravity feed-spouts.

Two electric-driven 5"×12" flight conveyers will deliver coal for boiler use into the coal bunker. One conveyer driven by a 10-horsepower direct-current motor will operate from the No. 4 hoist shaft, and the conveyer from the No. 5 hoist shaft will be driven by a 15-horsepower direct-current motor.

Draft for the boilers is obtained from a reinforced concrete stack, erected by the Alphons Custodis Chimney Construction Co. The stack is 181 feet high, from bottom of the foundation, and 10 feet inside diameter, the wall thickness is 16 inches and 10 inches for a height of 52 feet, and 8 inches thick from this point to the top of chimney. For the first one-third of its height the chimney is of double-wall construction, having an outer shell of concrete and an independent fire lining, with an air space separating both. The stack is equipped with outside ladder and a 4-point lightning rod. For support of the chimney a heavily reinforced square concrete base was placed, measuring 35 feet by 7 feet deep.

The power house is 47 ft. 4 in.×71 ft. It contains three Western Electric Co. generators, each of 200-kilowatt, 250-

volt, direct-connected to 18"×21" Erie engines with automatic cut-off slide valves and inertia governor, regulated 1½ per cent. above or below normal speed. These generators will be used to furnish power for the mine-haulage motors and the electric coal-cutting machines installed in each seam. A 25-kilowatt, 125-volt, steam, turbine generator, running 3,500 revolutions per minute, is provided for lighting the buildings, tipples and

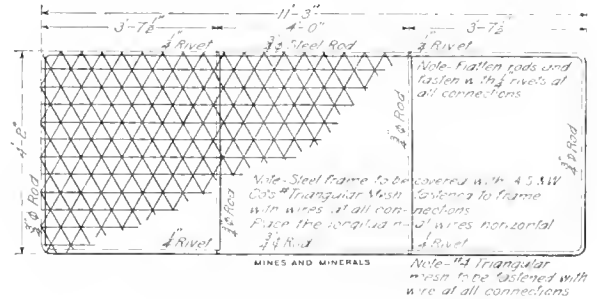

FIG. 10. STEEL FRAME SUPPORTING REINFORCEMENT

shaft bottoms. A 5-ton-capacity, hand-power, chain block, overhead traveling crane, with a span of 42 feet 4 inches, supplied with a trolley, will handle all parts of machinery necessary to remove. Ample floor space is provided for future installation. A feature in this building was the placing of a basement with 5 feet clear headroom, making it easy of access to reach conduits and steam lines, the latter in case of leaks, without tearing up the floor. Fig. 15 shows an interior view of the boiler house, concrete bunker, and column supports.

The hoist engine houses are each 30 ft. 3 in.×35 ft., located at each shaft, and house Danville hoisting engines. The engine for the No. 5 shaft is 20 in.×36 in., with 72-inch drum, and for the No. 4 shaft 24 in.×36 in., with 84-inch drum, both engines being direct acting. The hoisting cage ropes are 1¼-inch diameter. The mine cages operated by the engines are of the self-dumping type and were made by the H. C. Frick Coke Co., at their Everson, Pa., car shops, the cage platforms being 6 feet 6 inches wide by 11 feet long.

The two fan houses, each 12 ft.×27 ft., cover a Buckeye 20"×30" self-oiling type, high-speed engine, of heavy design, working under 125 pounds steam pressure, placed in parallel on either side of the ventilating fan, which is erected between them and direct-connected thereto. Both engines are controlled with Anderson emergency stop valves, permitting the quick cutting-off of the steam from both engines.

The ventilating fan is a Clifford-Capell type blower fan, designed for reversing, and capable of a delivery of 250,000 cubic feet of

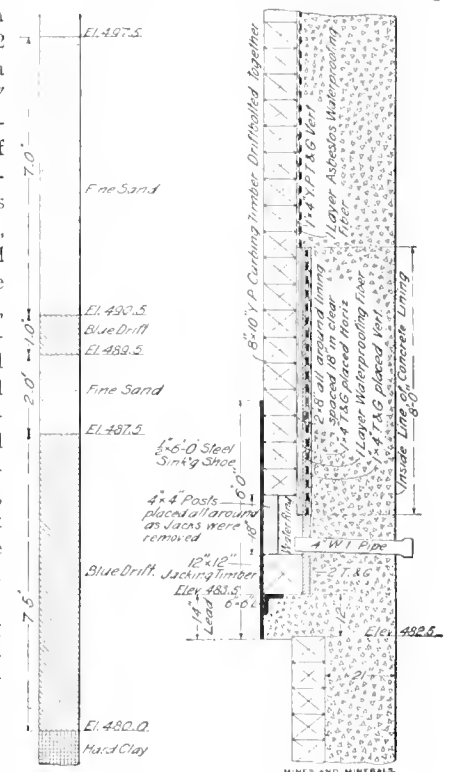

FIG. 11. PLACING OF WATERPROOF LINING

air per minute against a mine resistance represented by a 5-inch water gauge. The fan is 5 ft. 6 in. \times 20 ft. with double inlet. Doors are provided in the drift to regulate or shut off entirely the flow of air into either of the air compartments, should it become necessary.

The repair shop is 30 ft. 3 in. \times 91 ft., divided with concrete partition walls into three parts, for blacksmith, machinist and electrician. The shop is equipped with lathes, planers, drill presses, power hammer, pipe-cutting and threading machines, forges, hand and circular saws and bending machine. The machinery is all belt-driven by power from a 50-horsepower electric motor.

The plant office building is 34 ft. \times 40 ft. and is built of smooth-faced concrete blocks. It is 2½ stories and is provided with sleeping and bath rooms. This building has an excellent location, overlooking the yard tracks and plant.

Other buildings include stable, 38 ft. \times 50 ft.; granary, 28 ft. 6 in. \times 35 ft.; storehouse, 23 ft. 8 in. \times 45 ft. 8 in.; pump house, 11 ft. \times 15 ft.; and power house, 20 ft. \times 25 ft. The roofs of the main buildings are covered with reinforced-concrete tile, colored red on the surface, and make a good appearance in contrast to the white concrete walls.

The powder house is located along the railroad siding, 800 feet from shafts, and is of sufficient size for the storage of two carloads of explosive, which is transported by narrow-gauge track from the powder house to the shafts.

The steam line piping for the entire plant was made at the

Everson car shops of the H. C. Frick Coke Co., which company also received the contract for erection.

At the No. 5 tippie there is an electric freight elevator. The platform is 7 ft. 6 in. \times 10 ft. 6 in., and the elevator has a capacity to lift 4,000 pounds in addition to weight of the car. The hoist is operated by a 10-horsepower direct-current motor of 250 volts. The elevator is provided with automatic engine stop and safety brake. The purpose of instalment was for the conveying of mine cars or material

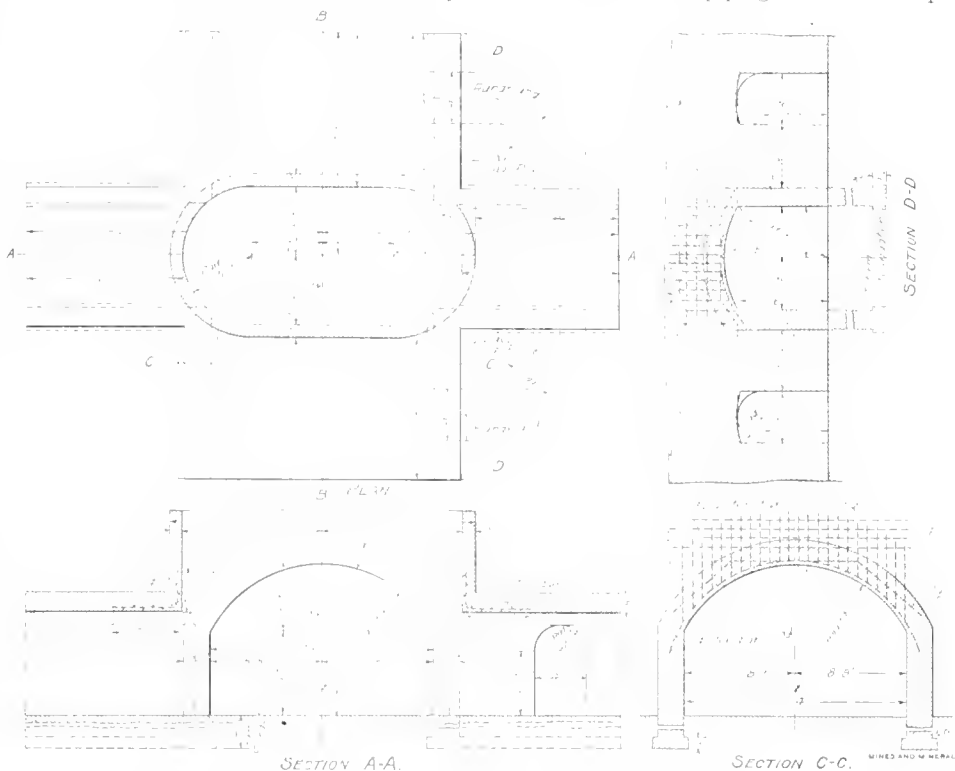

FIG. 12. CONCRETE WORK AT SHAFT BOTTOM

from the shop or surface to the No. 4 tippie, by way of the rock-landing track, without stopping the hoisting of coal from the shaft. Reinforced concrete floors are provided in the scale room, around sheave wheels, and in the runways around the shaker screens on each tippie. Both tipples are provided with bar and shaker screens for the loading of lump, nut, and slack coal. Three tracks at each tippie will take care of the output for each grade of coal. The railroad tracks are all on a gravity

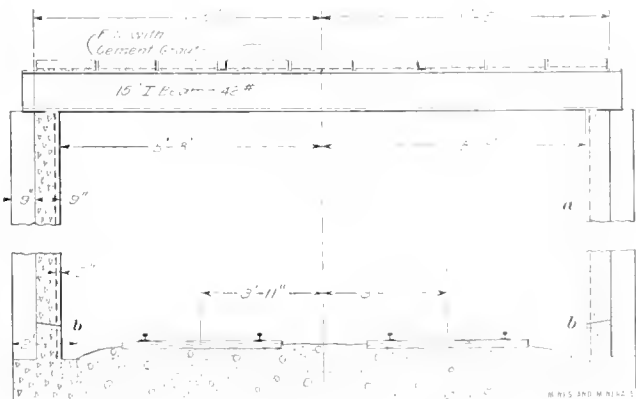

FIG. 13. SECTION OF HEADING, SHOWING CONCRETE SLAB WORK

The miners' bath house is 31 ft. \times 62 ft., and is situated near the ventilating shaft. There are 20 individual wash bowls located along one side of the building, while on the opposite side there are 15 shower heads provided. Rows of seating benches are placed to accommodate 75 men. Hot and cold water is supplied. The men's clothes are raised in brass rings by means of chain and pulley and suspended near the ceiling, lock and key being provided for each man.

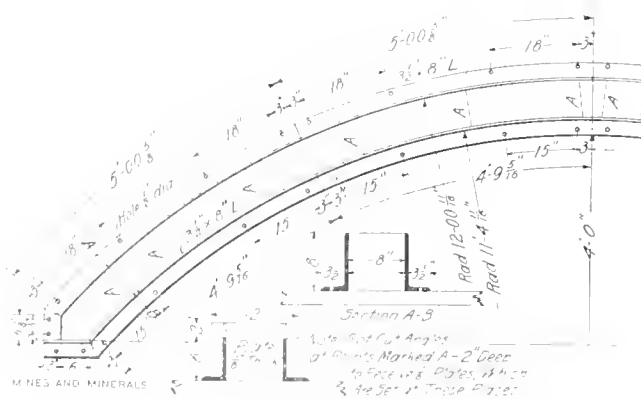

FIG. 14. STEEL FORM FOR MAKING CONCRETE BLOCK ARCH

grade and sufficient room is provided above the tipples for the storage of 80 empty railroad cars. Between each set of tippie tracks a run-around track is provided, leading to the main-branch tracks.

Water System.—The water supply for the entire plant is taken from two 12-inch pipe-cased wells, sunk into the sand and gravel water-bearing strata to a depth of 35 feet below the surface of the ground. The location selected for these wells was

at a point where level basin was found to be the deepest, and was determined by driving a line of bore holes. The pump house situated at this point contains two 10" x 36" Cook's angle, direct acting, deep-well pumping engines, driven by steam. These are fitted for 9-inch suction and 4-inch discharge pipes. In each well is placed a brass 12' x 9" patent Cook strainer, with slot openings 1/16-inch in width. The pumps deliver the raw water into two tanks, each with a capacity of 70,000 gallons. The water at this point is chemically treated and filtered and piped by gravity into a concrete waterproofed lined cistern, located just outside of the boiler house. The cistern is 15 feet in diameter by 15 feet deep, and has a capacity of 20,000 gallons of purified water. The "Buda" water softening system, of intermittent type, with a capacity of 10,000 gallons of treated water per hour, was installed. The purified water for boilers and plant use is stored in a steel tank, 35 feet in diameter by 35 feet in height, having a capacity of 250,000 gallons. This tank is supplied by water from the cistern and discharged into the tank by two steam-driven, duplex, 10" x 8" x 15", fresh-water pumps, located in the boiler house. The water head from this tank is 75 feet, and sufficient for all supply purposes and fire protection. The water lines are all of steel-



FIG. 15. INTERIOR OF BOILER PLANT

line screw pipe, coated both on the inside and outside with asphalt. The main lines are 6-inch and branch lines to fire plugs 4-inch diameter. The hot-water supply for the bath house and office building is taken from a vertical hot-water heater, 5 feet diameter by 11 feet high, located in the boiler house, having a capacity of 1,600 gallons. A light-pressure 6" x 4" x 6" hot-water pump discharges the water at a temperature of 160 degrees to these buildings through 2-inch covered galvanized steel pipe. Fig. 16 shows a view of the water-purifying plant, concrete stack, and the boiler house, during construction.

Company Houses - Erection is under way for the following frame dwellings: one superintendent's house, three 5-room single tenement houses, five 8-room double tenement houses, and six 3-room, 1-story, tenement houses. These dwellings will be used by the bosses and men required to stay at the plant. When the mines are in operation it is the intention to run a miners' train to the plant from Clinton. The houses will be supplied with electric lights and purified water. A 4-inch high-pressure water line, with double fire plugs at regular intervals, will afford ample fire protection. Hose houses, 6 ft. 8 in. x 6 ft. 8 in., and hose-drying towers, 7 ft. x 7 ft., and 15 feet high, will be erected at the shaft site, and also at a convenient point adjacent to the company houses.

UNIVERSAL MINE. No. 4 HOISTING SHAFT. GEOLOGICAL SECTION AND ELEVATIONS. ELEVATION OF COPING, 526 FT.

Material	Thickness of Bed in Feet	Total Depth to Bottom of Bed	Elevation Bottom of Bed
Fill	5.00	5.50	520.50
Surface soil	5.00	10.50	515.50
Sandy clay	8.50	19.00	507.00
Hard pan	1.00	20.00	506.00
Fine sand (water)	4.00	24.00	502.00
Sand and gravel (water)	4.50	28.50	497.50
Fine sand (water)	7.00	35.50	490.50
Blue drift (clay)	1.00	36.50	489.50
Blue sand	2.00	38.50	487.50
Blue drift	7.50	46.00	480.00
Hard clay	14.00	60.00	466.00
Blue drift	8.00	68.00	458.00
Sand and gravel (water)	6.00	74.00	452.00
Clay	2.00	76.00	450.00
Sand, gravel, and drift (water)	6.50	82.50	443.50
Fine sand (water)	3.50	86.00	440.00
Cemented sand, shale, and gravel	6.50	92.50	433.50
Shale	5.50	98.00	428.00
Black slate	.33	98.33	427.67
Coal	1.67	100.00	426.00
Fireclay and limestone boulders	12.00	112.00	414.00
Black slate	8.00	120.00	406.00
Coal	.75	120.75	405.25
Black slate	3.25	124.00	402.00
Coal No. 5 seam	5.00	129.00	397.00
Fireclay and limestone boulders	3.50	132.50	393.50
Limestone	4.00	136.50	389.50
Shale, sandstone	2.00	138.50	387.50
Sand rock	6.00	144.50	381.50
Fireclay, shale, and slate mixed	39.00	183.50	342.50
Black slate	5.00	188.50	337.50
Coal	2.20	190.70	335.30
Fireclay	4.30	195.00	331.00
Fireclay and limestone	11.00	206.00	320.00
Slate with limestone boulders	17.25	223.25	302.75
Coal No. 4 seam	5.00	228.25	297.75
Fireclay and limestone boulders	11.00	239.25	286.75
Slate (bottom of sump)	10.00	249.25	276.75

The No. 4 shaft has an area of 211 square feet inside, and was concreted to the coal, a depth of 235 feet. The greatest progress made in excavation in any one week was 21 feet; and the greatest depth concreted in any one week was 36 feet. A summary of progress is as follows: Total number of weeks worked, to reach bottom of coal, 26; average depth sunk per week (sinking 22 weeks), 10.7 feet; average depth of concrete lining placed per week (concreting 11 weeks), 21.4 feet; average depth of sinking and concreting for 26 weeks, 9 feet; average depth of sinking and concrete lining placed per month; 40 feet. Steel shoe carried down 42 1/2 feet below top of coping.

UNIVERSAL MINE. No. 5 HOISTING SHAFT. GEOLOGICAL SECTION AND ELEVATIONS. ELEVATION OF COPING, 526 FT.

Material	Thickness of Bed in Feet	Total Depth to Bottom of Bed	Elevation Bottom of Bed
Fill	5.2	5.2	520.8
Surface soil	5.0	10.2	515.8
Sandy clay	6.0	16.2	509.8
Clay and sand	5.6	21.8	504.2
Fine sand (water)	1.0	22.8	503.2
Sand and gravel (water)	8.5	31.3	494.7
Fine sand (water)	8.2	39.5	486.5
Blue drift (clay)	37.5	77.0	449.0
Sand (water)	.5	77.5	448.5
Blue drift	2.5	80.0	446.0
Fine sand	3.5	83.5	442.5
Blue drift	3.0	86.5	439.5
Cemented sand and gravel	5.0	91.5	434.5
Shale	3.0	94.5	431.5
Sand	1.0	95.5	430.5
Black slate	4.0	99.5	426.5
Coal	2.2	101.7	424.3
Fire clay and limestone boulders	8.0	109.7	416.3
Black slate	16.4	126.1	399.9
Coal No. 5 seam	5.0	131.1	394.9
Fireclay and limestone boulders			
Slate (bottom of sump)			

No. 5 shaft at the Universal mine has an area inside of 211 square feet, and is concreted from the surface to the coal, a depth of 131 feet. The greatest depth excavated in any one week was 16 feet, and the greatest depth concreted in any one week was 51 feet. A recapitulation of progress follows: Total number of weeks worked, to reach bottom of coal, 22; average depth sunk per week (sinking 17 weeks), 7.7 feet;

average depth of concrete lining placed per week (concreting 5 weeks), 26.2 feet; average depth of sinking and concreting for 22 weeks (per week), 6 feet; average depth of sinking and concrete lining placed per month, 30 feet. Steel shoe carried down 85½ feet below top of coping.

The total depth, 171.5 feet, of No. 5 ventilating shaft was lined with concrete. The inside area of the shaft is 325 square feet. The greatest progress in excavating was made during the

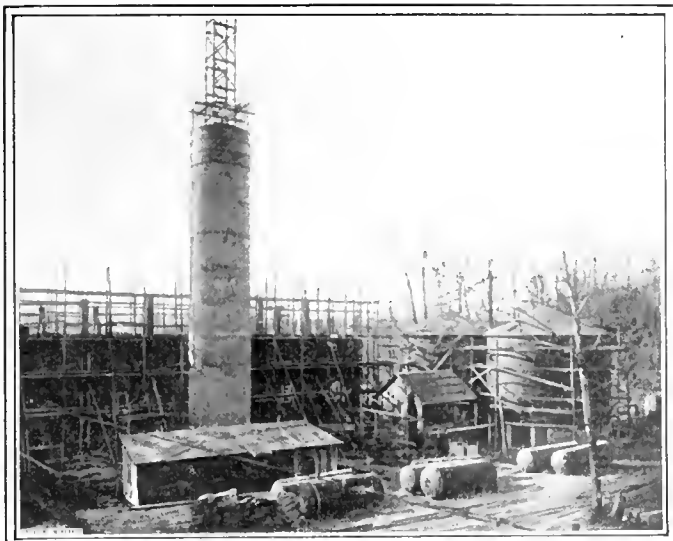

FIG. 16. WATER PURIFYING PLANT, STACK, AND BOILER HOUSE

week ending June 16, when at a depth of 126 feet, 20 feet was excavated. The most concrete lining placed in any one week was during the week June 9, when at a depth of 91 feet, 35 linear

UNIVERSAL MINE. VENTILATING SHAFT TO No. 5 SEAM. GEOLOGICAL SECTION AND ELEVATIONS. ELEVATION OF COPING, 565 FT.

Material	Thickness of Bed in Feet	Total Depth to Bottom of Bed	Elevation Bottom of Bed
Fill	3.2	3.2	561.8
Surface soil	5.8	9.0	556.0
Sand and gravel	14.0	23.0	542.0
Sand, gravel, and drif (water)	16.0	39.0	526.0
Blue drif	3.0	42.0	523.0
Sand and gravel (water)	9.0	51.0	514.0
Blue sand (water)	30.0	81.0	484.0
Sand shale	14.0	95.0	470.0
Sand rock	16.0	111.0	454.0
Slate	31.2	142.2	422.8
Coal	2.3	144.5	420.5
Fireclay and slate	22.0	166.5	398.5
Coal No. 5 seam (bottom of coal)	5.0	171.5	393.5

feet was put in place. A summary of the progress of excavating and concreting is as follows: Total number of weeks worked, to reach bottom of No. 5 coal, 20; average depth sunk per week (sinking 18 weeks), 9.5 feet; average depth of concrete lining placed per week (concreting 15 weeks), 11.4 feet; average depth of sinking and concreting for 20 weeks, 8.5 feet; average depth of sinking and concrete lining placed per month, 34 feet. Steel shoe and concrete caisson carried down 84 feet below the top of coping by the weight of the concrete.

來 來

Mechanical Laboratory Sampler

To keep the standard of market coal normal large coal companies are continually making tests to ascertain the heat units in the coal they are shipping. This procedure is a check on the preparation and also a check on the inspector, and is particularly important where coal is prepared in a wet way.

Frequently coal is condemned by its looks, because the muddy water in which it was prepared has dried and thus

spoils its lustre but not its heat units. It is hard to convince the average consumer of this, however, and the coal companies do not try, their position being that the consumer is to be pleased.

To make sure of their position, however, in the matter of shipments they sample the coal as it is being prepared for market and this tells the tale. The Philadelphia & Reading Coal and Iron Co. keep continually sampling and testing, the latter being done at their chemical laboratory at Pottsville. As the samples come in they are broken in a laboratory jaw crusher run by a small motor. After this operation the crushed coal is placed in the hopper *a* of the sampler shown in Fig. 1. The coal falls through the ¾-inch aperture in the bottom of the hopper on to a riffle sampler—that which falls in the grooves, being one-half, slides down to the chute *b* and is deflected to the next set of riffles. The discard takes the direction given it by the chute *c* and goes to the bottom of the case that encloses the riffles. The lowest riffle sample goes by chute *d* into the sample box *e*, which is a drawer that can readily be removed and inserted at will. The discharge at *f* is so arranged that all dust and discarded coal goes outside the laboratory where the latter can be removed readily. Assuming that the sample is 100 pounds, then when it reaches the sample box it is reduced to 6.75 pounds. In case the sample was 50 pounds it would be placed in the first side hopper or *g* and be reduced to the same quantity, or in case it was a 25-pound sample it would be placed in hopper *h*, and so on, the final sample being 6.75 pounds. The sample is removed from the sampling box, reduced to its proper size and placed in a labeled bottle until it is tested for its heat units in a calorimeter, or analyzed if that be the object.

Taken as a whole this is the most up-to-date and convenient coal sampler known, and the writer wishes to acknowledge his appreciation to Messrs. A. G. Blakeley and E. M. Chance, of the Chemical Department, for their kindness in allowing the use of their drawing and information concerning so useful an apparatus. General Manager Richards encourages the

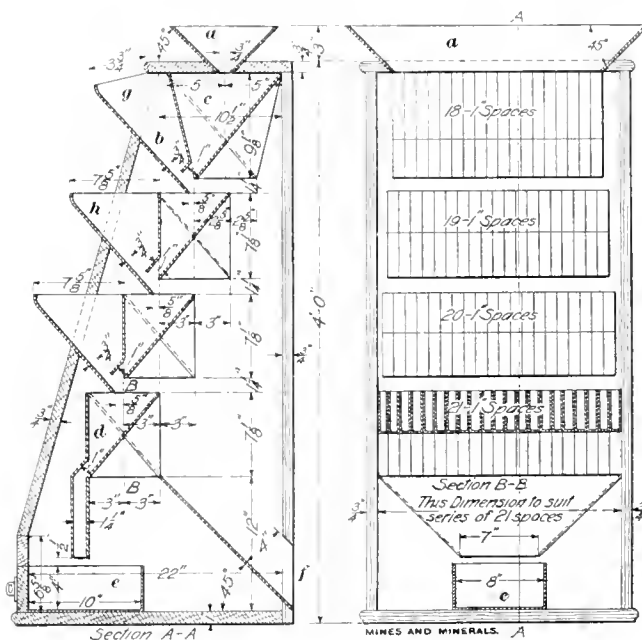

FIG. 1. LABORATORY COAL SAMPLER

men under him to make improvements in their various lines and in so doing aids the industry as well as the company and his subordinates.

This sampler might be adopted for making near analyses of coal by means of specific gravity solutions. Such physical tests of jig products would materially assist the jig tender in keeping his machines properly keyed to their work.

The Puritan Mine

Some Interesting Features in the Equipment of One of the Newer Colorado Coal Mines

By Joseph Watson*

About 4 miles northeast of the town of Erie, Colo., and not far from Denver, is the Puritan mine of the National Fuel Co. Its situation on the flat plain which terminates a short distance to the west in the foot-hills of the Rocky Mountains is extremely favorable to economic surface construction and operation. At the same time, the shape of the property, 1 mile in length from north to south and $\frac{1}{2}$ mile in width, lends itself to the modified three-entry retreating system of mining, which has been adopted. The surface equipment consists of the head-frame, machine shop, boiler house, etc., usual in a plant of 2,000 tons daily capacity, to which extent the mine is developed and is arranged to be operated with the minimum amount of labor. When running at a rate of 1,000 tons per day or less one man is sufficient to dump and weigh the coal, but beyond this tonnage a boy would be required to remove the checks from the pit cars. Ventilation to the extent of 115,000 cubic feet of air a minute is produced by an 18' x 5' Sterling fan direct-connected to a 12" x 20" engine. The fan is at present arranged as a blower but may be quickly changed to an exhaust when desired.

The coal, a perfectly clean lignite, is found in a practically horizontal position at an average depth of 125 feet from the

The loss of some of this upper coal in the pillars is in a measure offset by the saving in entry timber, the roof coal being sufficiently strong to sustain the roof without support.

Sinking was begun on the hoisting shaft on February 17 and was completed on May 3, 1908, to a depth of 122 feet. This shaft has three compartments, two, each 5 ft. 10 in. x 7 ft. 4 in., being used for the self-dumping cages, and the third, 2 ft. x 7 ft. 4 in., containing the pipe and electric wire lines. Immediately after beginning to drive the main entries, the air-shaft was started and was finished by August 30, 1908. This shaft is divided into two compartments, 6 ft. 1 in. x 7 ft. 8 in. and 2 ft. x 7 ft. 8 in., respectively, and is timbered with 4-inch white pine planking set skin to skin.

Mining, as the map indicates, is carried on upon a modified three-entry system, the modification consisting in that the main entries, which divide the property lengthwise in half, are double instead of triple. This change was made to reduce the cost of entry driving, but in order that the velocity of the air current of 115,000 cubic feet per minute may not be excessive

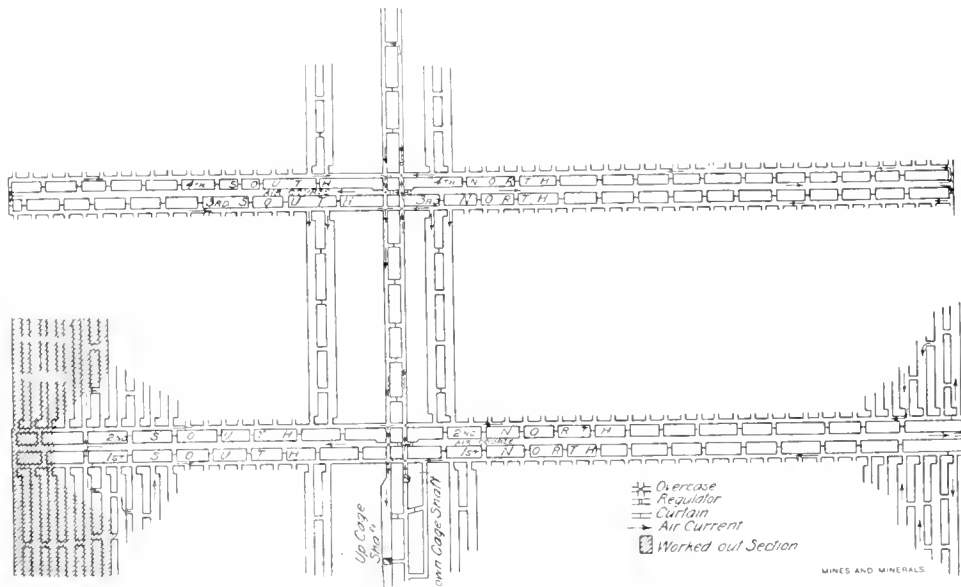

FIG. 1. MAP OF PURITAN MINE

on these two entries, the first room on each cross-entry is maintained as a return. It will be noted that the main haulage road, with the fan arranged as a blower, is the return airway instead of the intake. As the mine does not generate explosive gas, this is safe and the cagers, etc., are much more comfortable, particularly in winter. The main entry and air-course are each 10 feet wide with a 30-foot pillar between them.

The butt, or cross, entries are triple and spaced 500 feet apart, the middle one, the air-course, being driven 16 feet wide to save in yardage. Rooms are turned with 40-foot centers (room

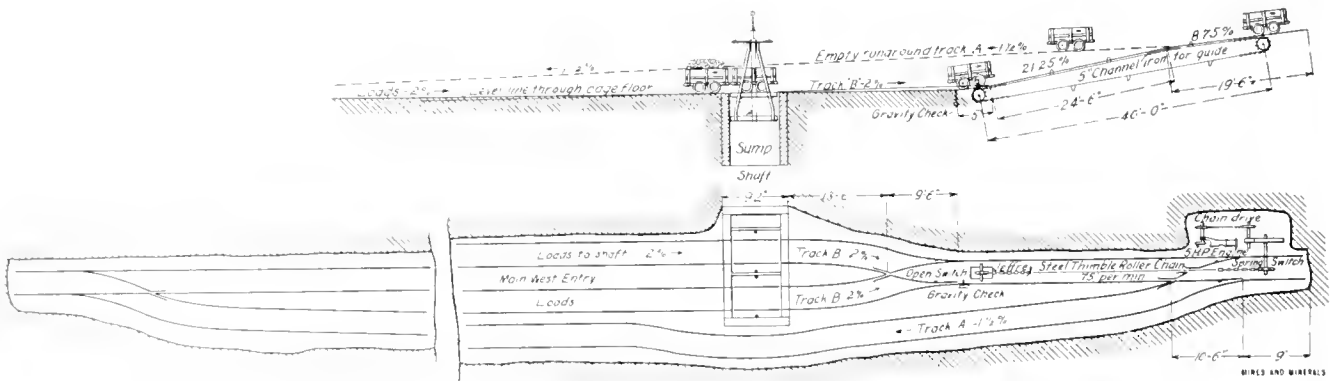

FIG. 2. PLAN OF SECTION OF SHAFT BOTTOM AND CAGING ARRANGEMENTS

surface. With a soap-stone roof and a sandstone floor the seam maintains a uniform thickness of 10 feet. Owing to the rapid disintegration of the roof when exposed to air, 2 feet of top coal is left up in the rooms and 3 1/2 feet in the entries, but the major portion of this is recovered when the pillars are drawn.

* General Superintendent, National Fuel Co., Louisville, Colorado.

width 20 feet) from each of the two haulage entries and after being driven 250 feet the pillars are drawn at once. While the cross-entries are advancing the room necks are turned and the switches laid, but no wide work is begun until the entries reach the boundary of the property. When this occurs the rooms are widened out in retreating order from the face to the mouth

of the entry and when the innermost room reaches the limit of length, 250 feet, pillar drawing commences, the entry stumps being brought back at the same time.

The mine is entirely without doors and while the necessary overcasts were expensive, their cost was soon met by the saving in trapper's wages.

The coal is undercut by air punchers and the hauling done by mules, but arrangements have been made for a motor haulage when the workings are sufficiently far advanced to render the change advisable.

The caging is done from the west side of the shaft, Fig. 2. The loaded ear siding has a gradient of 2 per cent. so that when a car is released it runs easily to the foot of the shaft. After being bumped off the cage (which is provided with automatic keeps releasing the car when the cage is landed) by the oncoming load, the empty car runs down a grade of 2 per cent. to the foot of a chain haul which elevates it sufficiently for it to run over an automatic back switch and, on a grade of $1\frac{1}{2}$ per cent., to the empty siding on the west side of the shaft. The haul will handle three 2-ton capacity cars per minute, or 180 per hour, or a greater tonnage than that for which the surface plant is designed. The haul is 40 feet long between centers of foot and head sprockets and consists of a Jeffrey Mfg. Co.'s steel thimble roller chain having a safe working load of 6,000 pounds. The haul is designed for a traveling speed of 75 feet per minute, although it is usually run somewhat faster, say, at a rate of 100 feet per minute. The chain has a grip or dog, which comes in contact with an angle iron bolted to the bottom of the car, riveted to it and spaced so that there is no possibility of an empty coming down the haul meeting one coming up before the down car has had time to take and clear the switch leading to the empty siding. The car haul is driven by a 5-horsepower upright steam engine connected to a countershaft by a chain drive. This countershaft has a 7-inch pinion which meshes with a 48-inch spur gear on the main drive shaft. The cost of the machinery was under \$400, and that of installation, including the heading back of the shaft, under \$1,000, and has resulted in saving the labor of two men on a tonnage of 1,000 tons per day.

Experience has shown that placing the empty car elevator immediately back of the shaft, instead of in front of the shaft and about midway on the empty car siding as is usually done, results in less cost of installation and operation with fewer delays due to car being "hung up" on the back switch. As ordinarily arranged, there is room on the empty siding for 10 to 12 cars from the back switch to the foot of the elevator and this distance is saved by placing the haul immediately back of the shaft. At least 100 feet of wide work at the foot of the shaft is saved with a resultant decrease in the cost of construction and maintenance, particularly in the item for timber. Also cars are never hung up on the back switch as the elevator provides for a sufficient grade for the empties to run easily and quickly to the proper siding.

Although additional capital is required, the retreating system of mining has proven more economical in the end. The cost of track maintenance is small, less timbering than usual is required as the entries are free from squeeze and creep, and a maximum percentage of lump coal is recovered. The ventilation is also easy to maintain as there are no large open spaces to be aired, better and purer air is secured for the miners by the use of separate splits for each entry, and the number of brattices to be kept up diminishes instead of increases as the workings advance.

栗 栗

The petroleum wells of Ontario in 1910 yielded 14,723,105 gallons of oil, valued at \$559,478. This is a decrease of 3,756,442 gallons as compared with the production of 1908. The refineries, of which there are two in Ontario, distilled a total of 35,530,918 gallons of crude oil last year. Of this, 16,015,527 gallons was domestic and 19,515,391 gallons imported.

Safety Blocks at Castle Gate Tipple

As the loaded tracks on coal-mine tipples are always built on a 1- to 2-per-cent. grade in favor of the loads, in order to pass the cars over the dump by gravity, some device is necessary to prevent the loaded cars from passing over and wrecking the dump. The usual method is by spragging the cars, a dangerous and somewhat uncertain practice. Fig. 1 is a sketch of a device that has been installed and successfully used for this purpose of blocking the cars at the Castle Gate tipple of the Utah Fuel Co.

This device is very simple, is easily and cheaply constructed and can be used on most any tipple, eliminating at least one man or boy, the spragger.

This pair of blocks consists of two 10" x 15" timbers, bolted solid to the tipple floor at one end and movable at the other. The two timbers are connected by the pieces of 1" x 4" iron, these being connected by a $\frac{3}{4}$ -inch steel-wire rope to a lever located near the dump, so that the man in charge at the dump can operate it conveniently.

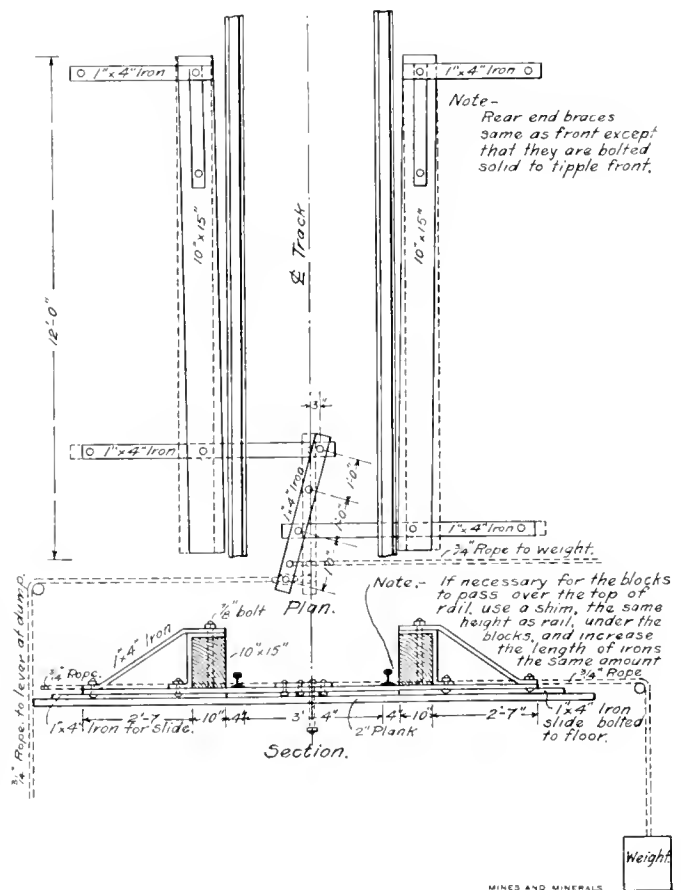

SAFETY BLOCKS, CASTLE GATE TIPPLE

When the blocks are closed, as they are at all times except when a car is being dropped through, the distance between the two timbers, at the lower end, is less than the distance from outside to outside of the car wheels and of course the trip cannot pass through.

When the dumpman wants a car, he releases the lever, the weight opens the blocks, and, as soon as one car has passed through, the blocks are again closed, thus holding the remainder of the trip.

While this arrangement was not designed to stop a runaway trip, it has been of service on several occasions in stopping trips traveling at greater than normal speed, which, had sprags been depended on, would have no doubt passed over and wrecked the dump, causing not only the loss for repairs but the loss due to an idle mine as well.

Waste-Heat Coke Ovens

Savings Possible, Illustrated by Plants at Stag Cañon, New Mexico, and Others

There is one coal company in West Virginia that although making coke burns approximately 82 tons of coal per day under a 3,800-horsepower boiler plant. In New Mexico there is a coal company that uses approximately 2,400 horsepower and produces this power from the waste heat of 218 beehive ovens. This is a mere drop in the bucket when the total number of beehive oven plants in the United States that waste coal is considered.

In studying the economy to be derived from the use of waste-heat ovens that most excellent coal known as the Pittsburg bed is taken. Theoretically this coal should furnish 68.38 per cent.

1,876,800 pounds per year, and assuming that the coal if burned under boilers would evaporate 10 pounds water per pound of coal, the saving in coal from the waste heat of one oven would be $\frac{1,876,800 \times 2.52}{10 \times 2,000} = 236$ tons per year. If this coal is worth \$1 a ton at the mine each oven would save \$236 per year. As a ton of coal in New Mexico is worth more at the tippie than in Pennsylvania it is probable that over \$51,000 in coal is saved yearly by the 218 waste-heat ovens. This is conservative, for the cost per ton at the tippie is considered rather than the selling price, and consequently includes no profit.

Carrying the approximate calculations to West Virginia, where it is assumed coal is worth 90 cents f. o. b. cars, the saving in coal due to waste-heat ovens in a 3,800-horsepower boiler plant would be nearly twice that at the New Mexico plant, or \$100,000 per annum.

It has been, and still is, argued that the extra cost involved

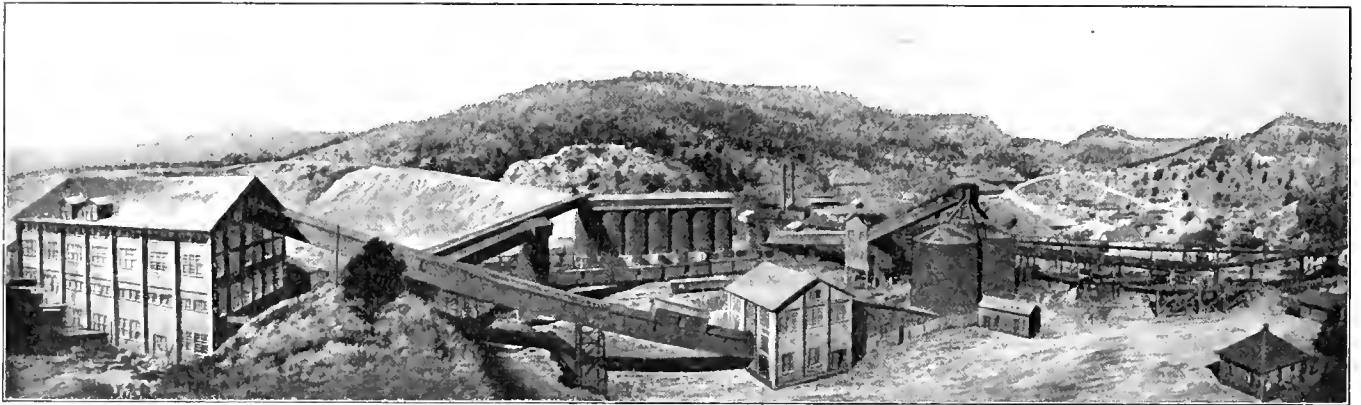

FIG. 1. PLANT OF STAG CAÑON FUEL CO., DAWSON, NEW MEX.

coke on an average; practically it yields 64 per cent. coke and requires 1.562 tons of coal to make 1 ton coke.

Assuming that the heating value of 1 pound of coke is 13,000 British thermal units, then $\frac{1}{1.562}$ pound produced from 1 pound of coal would represent 8,320 British thermal units. The heating value of Pittsburg bed coal is 15,300 British thermal units per pound and the loss in heat units during the process of coking is 6,980 British thermal units per pound, and it is this lost heat which, if utilized, would evaporate theoretically 7.2 pounds water. Owing to the radiation of heat from ovens and flues, not much if any over one-half the waste oven heat could be conducted to boilers, and even this quantity would depend on the location of the boilers relative to the ovens. It is authoritatively stated that the best water-tube boilers will absorb about 70 per cent. of heat, hence in this calculation it is assumed as possible to evaporate $7.2 \times .5 \times .70 = 2.52$ pounds water with the waste heat from each pound of coal coked.

If 6 tons of coal are charged into an oven every 56 hours or

in the construction of beehive ovens is unwarranted where there is no demand for gas in the vicinity of the ovens, and the argument prevails, and will for sometime to come, that waste-heat beehive ovens have not proved successful or they would have been adopted by some of the larger coke companies. While this argument appears sound, and there have been several failures when trying to use the waste heat from beehive ovens, the fact remains that there have been successes also, which suggests that the failures were due to the oven adopted, or some other cause. At Gary, W. Va., one kind was condemned because of the low percentage of volatile matter (16 per cent.) in the coal.

Besides the economic advantage in the use of waste heat for fuel, its comparative cheapness permits the use of increased machinery to do work otherwise neglected or performed by manual labor; again it permits of steam heat for buildings in winter, thereby lessening the consumption of coal and preventing coal chutes and slack bins from freezing in winter.

Where low-volatile coal is coked it will be found that if

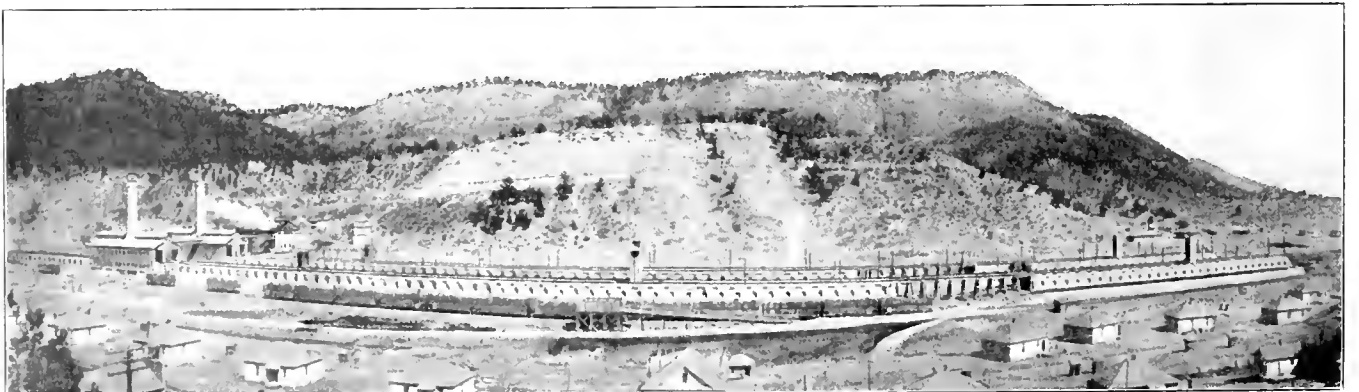

FIG. 2. BOILER HOUSES AND UNDER-FLUE COKE OVENS DAWSON NEW MEX.

crushed fine before being charged into the oven better coke will be produced and less breeze made, and this operation requires power.

In many instances it is necessary to wash coal in order to prepare it for market, a remark which leads to another; viz., that much good coking and steam coal is being condemned on account of sulphur showing in the analysis. Sulphur in all probability does not enter into combination with bituminous matter and if found in coal beds it is in the form of a sulphate or sulphide of an alkali metal or as iron pyrite, in any case it is as a mechanical and not as a chemical mixture in the coal bed.

If one will observe the location of pyrite when associated with coal, he will find it in the roof, floor, and partings, but not as a rule in the coal bed proper, therefore an analysis high in sulphur indicates that the coal will probably be high in ash, and likely to clinker. The impression prevails that sulphur causes clinker. This is erroneous; in fact, it is a preventative, for iron does not unite with silica until all sulphur has been oxidized, and even then, provided the coal is low in ash, clinkers will not be likely to form. If then the coal is crushed and washed, much now condemned can be made available for coking and also for steaming.

By permission the following is abstracted from J. E. Sheridan's paper* descriptive of the Stag Cañon Fuel Co., at Dawson, N. Mex. Twenty-seven electric motors, having an aggregate capacity of 1,159 horsepower are operated in conveying the coal from the tippie, through the crusher house and washery until it is delivered in the seven cylindrical steel storage tanks each 20-foot diameter, 40-foot high and holding 300 tons of slack coal.

There are 570 coke ovens in the operation, 124 of which are ordinary beehive ovens, 13 feet in diameter, the remainder being English under-flue ovens, 11 feet in diameter. Each oven is charged with 6 tons of slack coal and makes 52 per cent. in weight of 48-hour coke. An average analysis of the coal is as follows: Moisture, 1.8 per cent.; volatile matter, 37 per cent.; fixed carbon, 49.3 per cent.; ash, 12.5 per cent.; British thermal units of the coal, 13,291. The analyses of the coke furnished by General Manager T. H. O'Brien are as follows: Beehive: moisture, .2; volatile matter, 1; fixed carbon, 82.1; ash, 15.8; Under-flue: moisture, .2; volatile matter, 1; fixed carbon, 82.1; ash, 15.9.

In Fig. 2 is shown a general view of two parallel strings of under-flue coke ovens with boiler houses to the left between batteries of each string.

These under-flue ovens built in blocks of 54 and 58, are an innovation in this country, for which reason the details of their construction are given in Fig. 3, while their general outside appearance as shown in Fig. 2, does not differ materially from the regulation beehive oven.

The gases are partly burned in the oven and the flame escaping through the flue in the side of the arch, passes downward into the horizontal flues below the oven tile where coursing through them it finds an exit to the main flue between the ovens leading to the boilers. A cross-section of the main flue at the pair of ovens farthest from the boiler plant has an area of 20.6 square feet, and this is increased by dropping the flue bottom two bricks at each pair of ovens until at the down-cast of the boiler plant the sectional area is 52.73 square feet.

Pyrometer readings, at the boiler houses, show that the gases are delivered under the boilers at temperatures varying from 1,800° to 2,600° F., and leave the stack at temperatures of from 600° to 1,150° F.

At present the heated gases from only 218 ovens of the 446 under-flue ovens are being utilized, the return from the other 228 ovens being allowed to pass off through chimneys. Here are vast reserves of power that can be utilized to increase the capacity of the power plant as the mines increase in extent and production. There is one coke puller in use at the coke ovens, electrically driven by two General Electric motors, one of 20 horsepower and the other of 17.5 horsepower. This is shown in Fig. 4 to have an elevator and basket chute arranged so that the coke may be loaded

and spread in the car to the best advantage.

In the October, 1909, MINES AND MINERALS, there was an article, by R. D. Martin,* on "The Mexican Coke Industry," in which he described beehive ovens with waste-heat flues that were used in Agujita and Lampacitos, Mex. The construction of the oven and flue for utilizing waste heat is, as shown in Fig. 5, quite different from the New Mexico oven. The flue, shown in the course of construction in Fig. 6, is about 450 feet long and is located between block ovens, except midway of the flue for a distance of 8 ovens, where there is a single line of ovens so as to

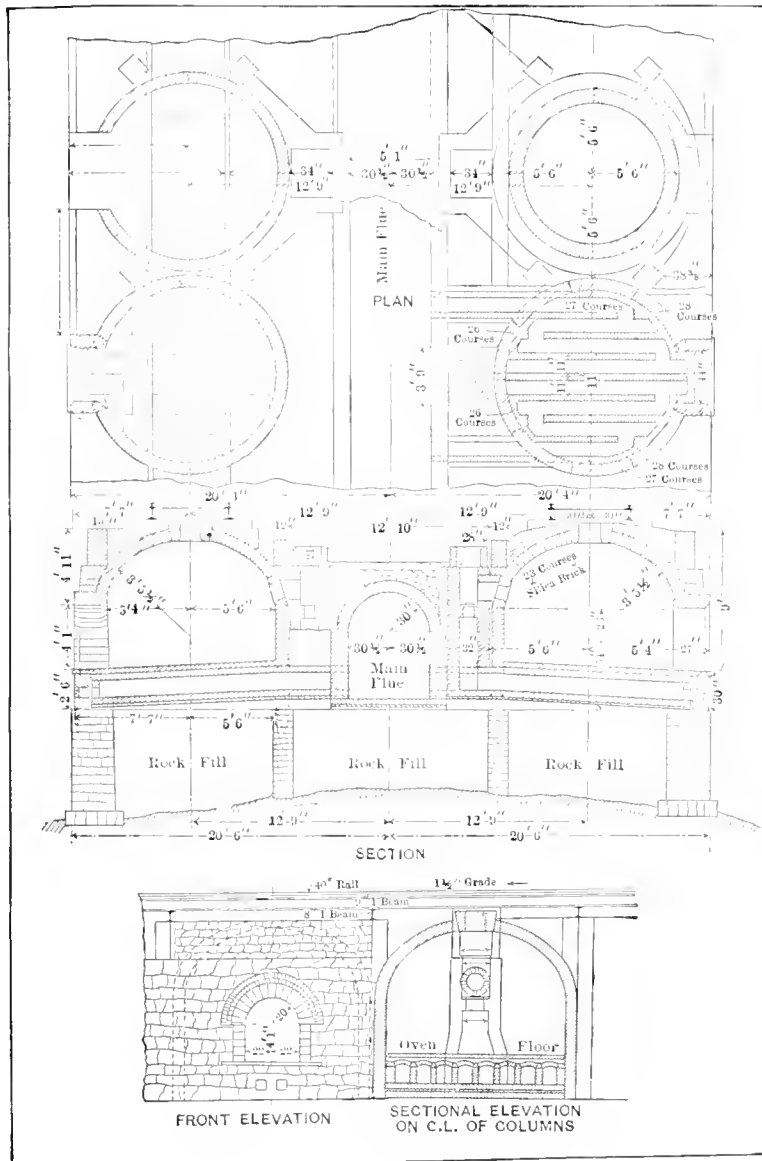

FIG. 3. DETAILS OF UNDER-FLUE COKE OVENS

*Trans. A. I. M. E., February, 1909.

*Contractor, Agujita, Coahuila, Mexico.

allow room for the boilers and stack to be recessed. The heat is conducted from each oven to the main flue as follows: On top of the usual trunnel head there is laid another ring 10 inches high, with a 10-inch section cut out of it on the side opening toward the main flue. On top of this cut ring another trunnel head is placed. There is an opening in the arch of the main flue in line with the opening in the cut ring on top of the oven. A flue 10 inches high connects the two openings. By placing a lid on the trunnel ring there is no place for the heat to escape except through the small flue into the main flue, thence through the right angle flues under the boilers and through to the stack. The firebox in the boilers give a temperature of 2,600° F., the test being made with Saeger cones. Mr. Martin estimates that each oven can be counted on to produce 12 boiler horsepower, with coal that has the following average analysis: Volatile matter, 21.1 per cent.; fixed carbon, 67.4 per cent.; ash, 11.5 per cent. The coke made in beehive ovens has approximately the following analysis: Fixed carbon, 83.3 per cent.; ash, 15.2 per cent.; volatile matter, 1 per cent.; and moisture, .5 per cent.

In the July, 1905, issue of MINES AND MINERALS, Howard N. Eavenson, Chief Engineer of the United States Coal and Coke Co., describes the waste-heat ovens at the No. 1 works of the Continental Coke Co. A section of the center of this oven is shown in Fig. 7. It was found that, on account of the insufficiency of draft, the last 10 ovens will not burn properly when connected with the flue. In spite of minor troubles, Mr. Eavenson says the flue is considered a success, since the 40 ovens furnish the heat needed for the boilers, save about 19 tons of coal daily, and \$2.25 in labor. At this plant 6 tons of coal in an oven gives about the same number of heat units under a boiler as 1 ton of coal fired. Mr. Eavenson says further that the ovens connected with the flue burn a little more coal than those not connected, although there is no difference at all in the quality of the coke. From the percentage of coke made at the Stag Cañon Fuel Co.'s plant it is also evident that there is some additional loss in fixed carbon due to the flue draft, over the loss due to coking in the ordinary beehive oven.

Sir Lowthian Bell estimated that there was 10 per cent. increase in yield in retort coke ovens over beehive ovens and modern practice proves his estimation conservative, therefore if 5 per cent. additional loss is to be added to the Pittsburg bed coal and 59 per cent. recovered as coke, the saving

in the using is nearly 18 tons from every 40 of the ordinary beehive ovens. In a recent article in MINES AND MINERALS, on "Retort Ovens in Mexico" their value as waste-heat savers was pretty thoroughly shown.

Book Review

DEPARTMENT OF MINES, Mines Branch, Ottawa, Can., Annual Report of the Division of Mineral Resources and Statistics on the Mineral Production of Canada, during Calendar Year 1909, by John McLeish, B. A.

ANNUAL REPORT OF THE MINISTER OF MINES FOR THE YEAR ENDING DECEMBER 31, 1910, being an account of mining operations for gold, coal, etc., in the Province of British Columbia, Bureau of Mines, Victoria, B. C., Can.

IRON MINES AND MINING IN NEW JERSEY, Volume VII of the Final Report series of the State Geologist, by W. S. Bayley, is now ready for distribution. It is a volume of 512 pages, bound in cloth, and accompanied by two large maps showing the location of all iron mines and prospects in the state. In addition to general discussion of the character,

occurrence and origin of the bog iron, limonite, hematite and magnetite ores, there are detailed descriptions of all the mines and prospects with many analyses of the iron ores. The report contains numerous mine maps and other illustrations. It will be sent to those interested upon receipt of 25 cents to cover cost of mailing. Application should be made to Henry B. Kummel, State Geologist, Trenton, N. J.

THE COPPER HANDBOOK, tenth edition, by Horace

J. Stevens, of Houghton, Mich. Eighteen months have been spent in an absolutely complete revision of the mine descriptions and statistical section of the book. The new edition, Vol. X, contains 1,902 octavo pages of text, and describes 8,130 mining companies, mines and attempts at mines, this being much the largest number of titles given in any work of reference

on mines. As in preceding years, there are several hundred pages devoted to the history, technology and uses of copper.

CONNECTICUT GEOLOGICAL AND NATURAL HISTORY SURVEY, Volume III, includes Bulletin 13, "The Lithology of Connecticut"; Bulletin 14, "A Catalog of the Flowering Plants and Ferns of Connecticut Growing Without Cultivation"; Bulletin 15, a second report on the "Hymeniales of Connecticut."

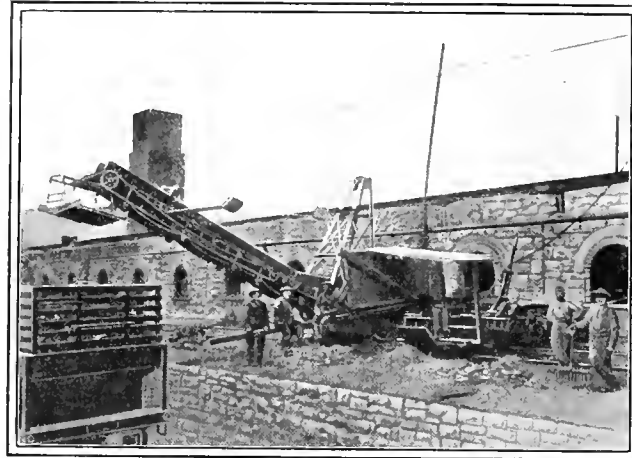

FIG. 4. ELECTRIC COKE PULLER

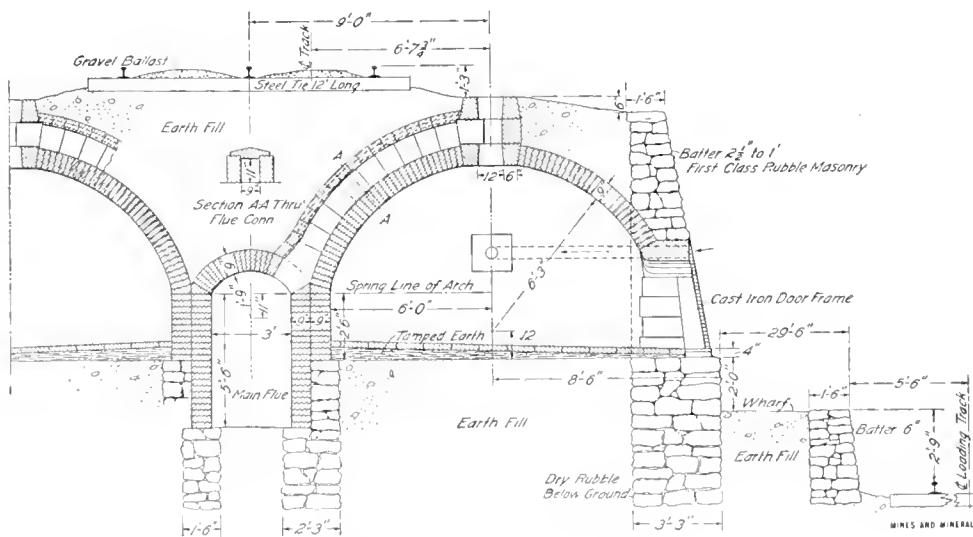

FIG. 5. CONSTRUCTION OF OVENS AND FLUE FOR UTILIZING HEAT

Trade Notices

A New Trolley Ear.—The General Electric Co. has recently placed on the market a new mechanical clamping ear, known as Form M, especially designed for use on overhead construction in and around mining and industrial properties. The ear consists entirely of forgings and punchings of steel, thus eliminating entirely such imperfections and variations as are common to iron castings. This feature also permits of using small light sections of great mechanical strength resulting in an ear giving a maximum clearance from passing trolley wheels and a minimum height from the center of the wire to the top of the clamping nut. The new ear is made up suitable for round, grooved and figure 8 wire and has either japanned or standard sherardized finish. The Form M ear, when used in connection with form H-3 suspension of the mining and ceiling type, renders possible an increase in head room of 1 inch to 2½ inches.

Demonstration of Electric Mine Lamp.—Recently a demonstration of the Pilley electric mine lamp was made in the Marianna mine before the officials of the company and others. As a result the company has placed an order for 1,000 lamps and expects to increase the number to 2,500 during the year.

Western Electric Co.—Arrangements have been completed whereby the Western Electric Co. will open a new house at Richmond, Va., where a complete stock of telephone apparatus and supplies, power apparatus and general electrical supplies will be carried. Mr. H. W. Hall, formerly manager of the Denver house, will have charge of the Richmond organization, and with him will be associated specialists on the various lines handled.

Core Drills of Large Size.—In a new catalog recently issued the McKiernan-Terry Drill Co. show the rapid progress that has been made in the development of the core drill for drilling large holes. The book shows illustrations of what has been accomplished and gives valuable data in regard to costs. It will be sent free upon application.

A Gravity Return Car Dump.—The Jeffrey Mfg. Co., of Columbus, Ohio, has just issued an illustrated bulletin descriptive of a new and practical automatic return car dump especially designed for small tipples and where space is limited. It not only delivers the coal without excessive breakage, but is also economical from a labor-saving standpoint, and permits the handling of an increased output. A

full-sized dump has been erected at the Jeffrey Co.'s plant at Columbus for the purpose of trying out the mechanism and for demonstration purposes. Mine managers who cannot conveniently visit Columbus to see the dump in operation can learn the details of the mechanism and its method of operation by sending for Bulletin No. 44A, which illustrates and describes it in a remarkably clear manner.

Automatic Safety Mine-Car Cages.—For handling mine cars at shaft bottoms and on tipples and inclines, the automatic safety mine-car caging machine, made by the Mining Safety Device Co., of Bowerston, Ohio, has shown high efficiency, enabling cars to be handled promptly and without danger of

accident to either men or machinery. Recently one of these devices has been installed at the mines of the Glen Ayr Coal Co., Terre Haute, Ind.; and two for the Superior Coal Co., Gillespie, Ill.

A New Feature of the Gandy Belt.—Owing to unscrupulous dealers and manufacturers endeavoring to palm off inferior goods as Gandy belting, the Gandy Belting Co., in addition to prominently marking the genuine Gandy belting at intervals with the Gandy trade mark, consisting of a coil of belt

and a bale of cotton laid across, have, beginning September 1, painted one edge of each roll or piece of belting green, while the rest of the belt will remain red, as formerly. The foundation of the Gandy belt is a very heavy cotton duck woven in the duck mills of the Gandy company. The sewing machines, on which the belts are stitched, are built in their own machine shops, and especially designed so that they sew with an imbedded stitch, making the surface of the belt smooth and holding the plies solidly together. The belt is then treated by a secret process to render it water, heat, and steam proof. All Gandy belting is thoroughly stretched and seasoned before it leaves the factory, and is invariably uniform in width. It runs straight and true and will not slip or harden. Belt users who know the Gandy belting, and those who desire Gandy quality in belting, are advised to look for both the trade mark and the green edge.

Laukenheimer Picnic.—When the National Association of Stationary Engineers held their twenty-ninth annual convention in Cincinnati, in September, and 3,000 were entertained by the Laukenheimer Company of that city, the engineers and their friends were taken on a steamboat to Coney Island picnic grounds. There were refreshments, dancing, and athletic events and at noon the crowd were feasted, burgoo and barbecued beef being special features of a menu of great variety.

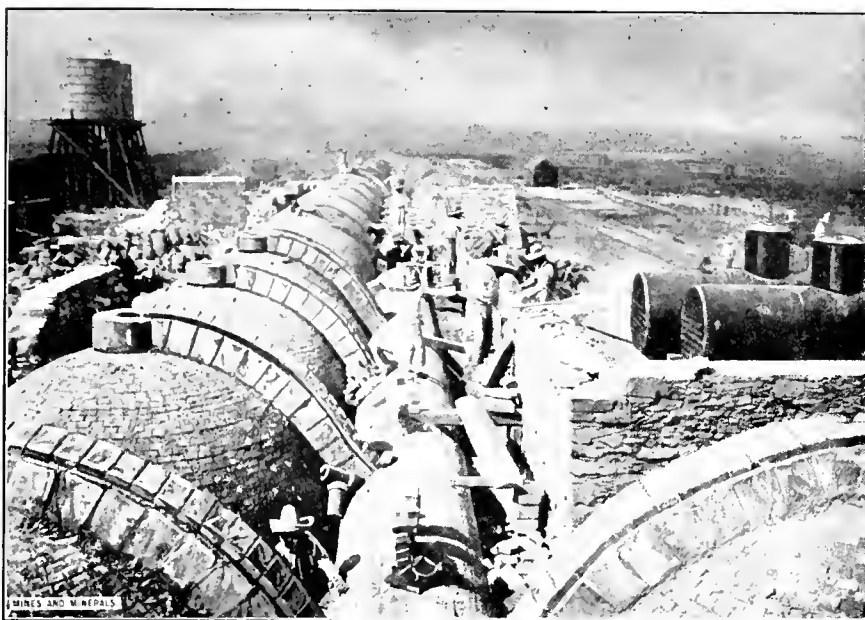

FIG. 6. OVENS AND WASTE-HEAT FLUE UNDER CONSTRUCTION, MEXICO

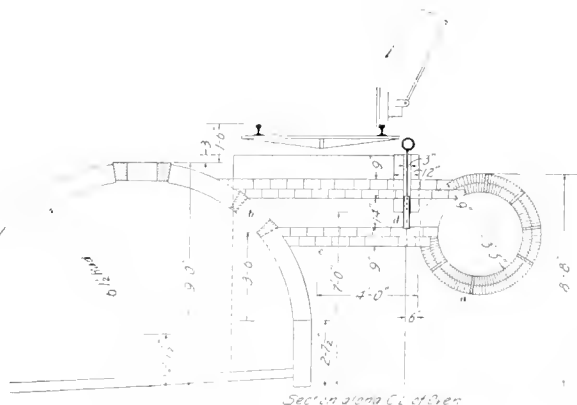

FIG. 7. SECTION OF OVEN, CONTINENTAL CORE CO

Annual First-Aid Contests

The annual first-aid contests of the employes of the coal companies in the anthracite regions of Pennsylvania give evidence of the interest taken in the subject by the companies and the men. There has been special interest this year on account of the first-aid exhibition to be held in Pittsburg in October, at which first-aid corps from all parts of the United States will exhibit before President Taft and other notables, and teams will be sent by most of the anthracite companies.

LEHIGH & WILKES-BARRE COAL CO. CONTEST

On August 26 the Lehigh & Wilkes-Barre Coal Co. held their annual exhibit at San Souci Park, near Wilkes-Barre, and corps to the number of over a hundred members took part.

Groups of teams contested in the first six events and a pennant was awarded to the winner in each. The winning corps then competed in the seventh event, the prizes for which were a bronze medal for each member. The successful corps was that from Baltimore shaft of the Ashley District.

The medals were presented by General Manager Huber, who, on behalf of the company, thanked the contestants for the faithful work they had done in training, and expressed appreciation of their high efficiency. The training was under the supervision of Dr. F. L. McKee.

At the conclusion lunch was served to over 600 members and invited guests.

D., L. & W. CONTEST

On August 31, 32 teams representing collieries of the D., L. & W. Co. competed in first-aid contests at the Scranton Y. M. C. A., and the work of the corps was witnessed by a large number of prominent mine officials from Wyoming and Lackawanna valleys. Teams from Nanticoke to Scranton and vicinity were represented.

A handsome silver cup, donated by the superintendent of the coal department of the company, was awarded to Captain Benjamin Lewis' team, representing the Woodward colliery, of Edwardsville. Captain Pierce's team from the Scranton district was a close second, and received honorable mention from the judges. The teams demonstrated extraordinary skill in the work accomplished by systematic training. The judges were Doctors Wainwright and Smith, of Scranton, and D. H. Lake, of Kingston.

FIRST ANNUAL FIRST-AID MEET PITTSBURG COAL OPERATORS' ASSOCIATION

The first annual first-aid meet of the Pittsburg Coal Operators' Association was held at Arsenal Park, Pittsburg, on September 9. Thirteen teams took part in the competition, and perhaps 500 men, representing practically all the coal companies of Western Pennsylvania, witnessed the meet. The showing made by all of the teams was remarkably good, considering the fact that some of them had received their first instruction in this work as late as 2 weeks previous to the meet.

Five special problems were given for the teams to solve, the winning team in each event being presented with an appropriate prize. Problem No. 5 was called the feature event, and the team winning this event was presented with a banner, which they are to hold for 1 year, and which must be won three times before it becomes the permanent possession of any team. This was won by the team representing the Pittsburg-Buffalo Co.

The judges were Dr. M. J. Shields of the American National Red Cross, Dr. J. B. Stoner, Surgeon of the United States Public Health and Marine Hospital Service and Mr. John C. Patterson, of the Youghiogheny & Ohio Coal Co.

The following is a list of the companies that were represented by competing teams: Pittsburg Coal Co., 5 teams; Berwind-White Coal Mining Co., 2 teams; Seanor First-Aid Association; Brier Hill Coke Co.; Pittsburg Terminal Railroad and Coal Co.; Pittsburg-Buffalo Co.; Ellsworth Collieries Co.; The Rochester & Pittsburg Coal and Iron Co.

S. A. Taylor, secretary and treasurer of the Pittsburg Coal Operators' Association, in an appropriate address, at the close of the program presented the prizes to the winning teams.

In the forenoon the testing laboratories of the United States Bureau of Mines were inspected and special experiments of educational value were performed by the employes of the Bureau.

PHILADELPHIA & READING FIRST-AID CONTEST

On Saturday, September 9, the first-aid corps from the various collieries of the Philadelphia & Reading Coal and Iron Co. held their seventh annual competitive drill at Lakeside Park, East Mahanoy Junction, Pa., to which about 2,000 employes and invited guests of the company, with three brass bands, were brought on special and other trains at the expense of the company.

Just as the contest was about to begin it commenced to rain, driving the crowd to whatever shelter could be found. Arrangements were quickly made, however, to continue the contest in a large pavilion on the grounds, and it was carried through as planned, showing the ability of the first-aid men to deal successfully with the unexpected under favorable conditions. The rain, which continued all the forenoon, also upset the plans of the caterer, to whom the company had entrusted the furnishing of dinner for the crowd, but he likewise rose to the occasion and though a little later than had been planned, was able to administer much appreciated "first-aid to the hungry" to the somewhat moist crowd.

The first contests were between the corps of each district, and the winners competed in the finals. This latter contest was of special interest, as the winning corps, in addition to receiving the pennant, is to be sent to the first-aid exhibit at Pittsburg in October.

The following are the winners of the finals and their percentages: Phoenix Park, 99; Wadesville, 99; Draper (outside), 98; Big Mountain, 97; Brookside, 97; North Mahanoy, 93; Knickerbocker (inside), 92; Reliance (outside), 91; Hammond (inside), 90.

In announcing the results, General Manager Richards stated that in the seven annual contests that have been held, over 3,000 men have competed, and considering the high standard of efficiency shown by all the contestants, the power for good exerted by that number of trained men scattered through the various collieries would be hard to estimate. He mentioned a case where a man severely burned in the mines was brought to the hospital, after being treated by one of the first-aid corps, and was found to be so carefully prepared that the surgeons were able to defer further bandaging or disturbance of the patient until he had had time to recover from the shock, which might easily have proved fatal with less prompt and skilful treatment.

It is worthy of note that the name of the corps doing this excellent work has not appeared among the list of winners in the contests of the last 3 years, which shows that the skill among the rank and file of the first-aid men is high.

The contests have become of great interest, and the personal acquaintance and evident good feeling between the officials and men are matters for congratulation to both alike.

FIRST-AID CONTEST PENNSYLVANIA COAL CO. AND HILLSIDE COAL AND IRON CO.

On September 2, the annual first-aid contest of the Pennsylvania Coal Co., and the Hillside Coal and Iron Co., was held at Valley View Park, Inkerman, Pa.

In addition to the contest proper, there was a demonstration of mine accidents. A piece of track had been laid, and on this two mine cars came together, showing how men are so often injured, and first-aid was administered to the supposed victim.

There was also built upon the grounds a representation of part of a mine gangway; this was filled with dense smoke, and men with oxygen helmets went in and brought out one of their

number, who was supposed to have been overcome by the heat, and administered first-aid treatment. This event was extremely realistic and served to remind many of those present of occasions they would rather forget.

The contest consisted of five events, and seven teams entered. The Board of Managers were W. P. Jennings, Henry T. McMillan, Dr. John B. Mahon, F. H. Coughlin, Dr. F. F. Arndt, Dr. M. J. Shields. The Secretary and Assistants were W. B. Evans, F. D. Conover, D. M. Howell. The judges of the contest were Dr. W. G. Fulton, former Major 13th Reg., N. G. P., Dr. J. W. Geist, Captain Medical Corps, 9th Reg., N. G. P., Dr. J. J. Rutledge, Mining Engineer, United States Bureau of Mines.

Events 1, 3, and 4, consisted in the treatment of patients supposed to be injured by falls, burns, and explosions.

The second event was to show three different ways of rescuing a man who had been overcome by an electric shock and had fallen on a live wire. It was of especial interest on account of the ingenuity shown by the contestants in devising means of rescue from whatever was at hand.

The fifth event consisted in dressing various severe injuries, putting the patient on a stretcher, and carrying him over a number of obstacles. This was contested for by full teams. The prize was a silver cup, and in addition the winning team will be sent to the First-Aid Exhibit to be held at Pittsburg, on October 27, all their expenses to be paid by the Pennsylvania Coal Co. and the Hillside Coal and Iron Co. The following percentages were made by the teams in this event: Avoca Central, 100; Dunmore No. 5, 96½; Mayfield, 95; South Pittston, Clarence, 93½; Forest City, 90; Plains, No. 14, 88½; North Pittston, Barnum, 75.

After the contest, H. M. Wilson, Engineer in Charge, United States Bureau of Mines, Pittsburg, addressed the company and presented the cup to the winning team.

Among those present was Dr. M. J. Shields, the founder of first-aid work in this country, now field representative of the American Red Cross Association, and in charge of the special Red Cross car; also Charles Enzian, Engineer of Bureau of Mines, in charge of United States rescue car for the anthracite regions; and Dr. J. J. Rutledge, Mining Engineer, Bureau of Mines, Pittsburg.

At noon, lunch was served to all present.

As similar contests are being arranged all over the country the following method of rating the contestants may be of interest

DISCOUNTING TABLE FOR FIRST-AID CONTEST

1.	For loose or "granny knot"	05
2.	For a loose bandage	05
3.	For loose splint	05
4.	For wrong artificial respiration	05
5.	For not stopping bleeding	10
6.	For not taking care of shocks.....	10
7.	For not doing the most important thing first	05
8.	For slowness in work.....	05
9.	For Captain's failure to command men properly.....	05
10.	Awkward handling of patient or stretcher	05
11.	Failure to be aseptic	05
12.	Failure to entirely cover wound	05

Team No. _____		Discounts—Base 100%												
Event	Operators	Total Credit	1	2	3	4	5	6	7	8	9	10	11	12
1st														
2d														
3d														
4th														
5th														

National First-Aid Field Day

At Pittsburg on October 30 and 31 there will be held a National Mine Safety Demonstration under the joint auspices of the American Red Cross, the Pittsburg Coal Operators' Association and the United Mine Workers of America, assisted by the United States Bureau of Mines. The Board of Managers are: H. M. Wilson, representing United States Bureau of Mines; Dr. M. J. Shields, representing American Red Cross Society; S. A. Taylor, representing the coal operators of the United States; Francis Feehan, representing the United Mine Workers of America; John Laing, representing the State Mine Inspectors; Thos. B. Dilts, representing Industrial Department of International Y. M. C. A. First-aid teams from all parts of the country, will be present and President Taft, Governor Tener of Pennsylvania, and other prominent men will take part.

On October 30, at the Arsenal Grounds, 40th and Butler streets, beginning at 9 A. M. and closing at 12 M., there will be a demonstration of the work of the Bureau of Mines, with exhibit of detonation of permissible and other explosives in the steel-lined gallery filled with dust and gas. There will also be exhibits and tests of mine safety lamps in the lamp gallery; of electric sparks in gallery No. 2 in the presence of an inflammable mixture of air and gas; of training in rescue work with oxygen helmets; of investigations and tests of explosives; views of smokeless combustion of coal; briquetting of coal and lignite, etc.

At 2:30 P. M. there will be an actual explosion at the experimental mine of the Bureau of Mines at Wallace Station, near Bruceeton, Pa. Train leaves B. & O. Railroad depot, Pittsburg, at 1:30 P. M. This mine has been opened and equipped by the Bureau of Mines with instruments for recording pressures, speed of travel of detonation wave, with various equipment for the making of actual mine explosions due to gas and dust, and their observation and study; also of conducting tests of coal-cutting machines, gasoline motor, electric motor, and other mine locomotives, and apparatus under working conditions within a mine.

On October 31, will be the first national mine-safety demonstration, held at Forbes Field, Pittsburg, Pa. The demonstration is under the management of the United States Bureau of Mines, the parade of miners under the auspices of the United Mine Workers of America. The following is the program:

At 9 A. M., at Forbes Field, Pittsburg, Pa., will be an exhibit of skill in first aid to the injured by teams of five miners from various coal operations in the United States, five separate events to be exhibited.

At 10:30 A. M. will be a demonstration by the Bureau of Mines in steel-lined mine gallery 200 feet long, of a permissible shot, followed by an explosion of black powder detonated in the presence of coal dust, with a resulting explosion of coal dust ignited by the non-permissible explosive, followed by a demonstration of rescue work. Men equipped with oxygen helmets will enter the gallery stair still filled with smoke and poisonous gases, will bring out injured men, and give them artificial respiration and first aid. There will be also a demonstration in dangerous practices within gaseous or dusty mines.

At 11:30 A. M., President Taft will deliver souvenir prizes to participants. Short addresses by the President, Governor Tener of Pennsylvania, and others will follow.

Following will be a parade of 19,927 miners, each of whom will represent one of the 19,927 men killed in the coal mines of the United States in the last 20 years. The miners will march in review before the President's stand, and then to special cars on Forbes Street, which will carry them to the river front where they will witness the marine parade.

From 2 to 5 P. M. the President will review the marine parade in honor of the centenary of the opening of steam navigation on the Ohio River.

At 7:30 P. M. there will be a dinner to President Taft at Hotel Schenley.

Coal Mining in Michigan

Geology of the Coal Measures—Saginaw Valley Mines Methods of Working

Except from the statistics relative to the output of coal furnished by the United States Geological Survey and the Commissioner of Labor, little is known of the Michigan coal field outside of that state. Alfred C. Lane, in Vol. VIII of the Michigan Geological Survey, gives as exhaustive a report as conditions will warrant and among other matters relative to the coal fields of this state says: "The coal area is variously estimated from 6,500 to 8,000 square miles, but the average thickness of the coal will not be more than 1.75 feet."

Taking account of the coal known to be over 2 feet thick, he estimates that there are 8,025,600,000 tons to be mined in Michigan. In the 1911 "Coal Trade" is the following statement: "Despite the claims of geologists as to resources, coal men are apparently agreed in the opinion that the Saginaw Valley, including Saginaw and Bay counties, which contain practically all the coal in Michigan worth mentioning, will never be anything more than a source of supply for the district which it now serves;

namely, upper part of the lower peninsula and a portion of the upper." Whatever claims other geologists put forth, Mr. Lane, who wrote in 1903, practically states that as an export proposition the Michigan coal fields are not in a position to compete with other states; however that may be, any field that can average for several years 1,653,000 tons of coal per annum, and raise production for home consumption to 2,035,800 tons, as this field did in 1907, is entitled to something more than local consideration.

Coal is said to have been mined near Jackson in 1835, also at Grand Lodge, Eaton County, in 1838. While some coal

is yet mined in those counties the principal output for the past 12 years has come from Bay and Saginaw counties. The output by counties, as reported by the Commissioner of Labor for 1910, is as follows:

	Tons
Bay.....	720,677
Eaton.....	1,598
Genesee.....	13,151
Ingham.....	1,873
Saginaw.....	661,188
Shiawassee.....	8,530
Tuscola.....	64,257
Total.....	1,471,574

The map of the lower peninsula of Michigan reproduced in Fig. 1 was compiled by A. C. Lane and shows the coal area of Michigan. Owing to the unconformity of the strata, to the excessive glacial erosion and subsequent deposits of moraine, a large part of the interior coal as located on the map is conjectural, except where holes drilled for water or brine have verified its existence. The boundary or edge of the coal basin has been pretty closely determined by outcrops as well as by drill holes. The coal beds of the basin are therefore better known where they outcrop, and least known in the center of the basin, where the cover is thickest. A section of the lower peninsula furnished by Mr. Lane in the Michigan Report mentioned is reproduced in Fig. 2 and his hypothetical correlation of the Michigan coal

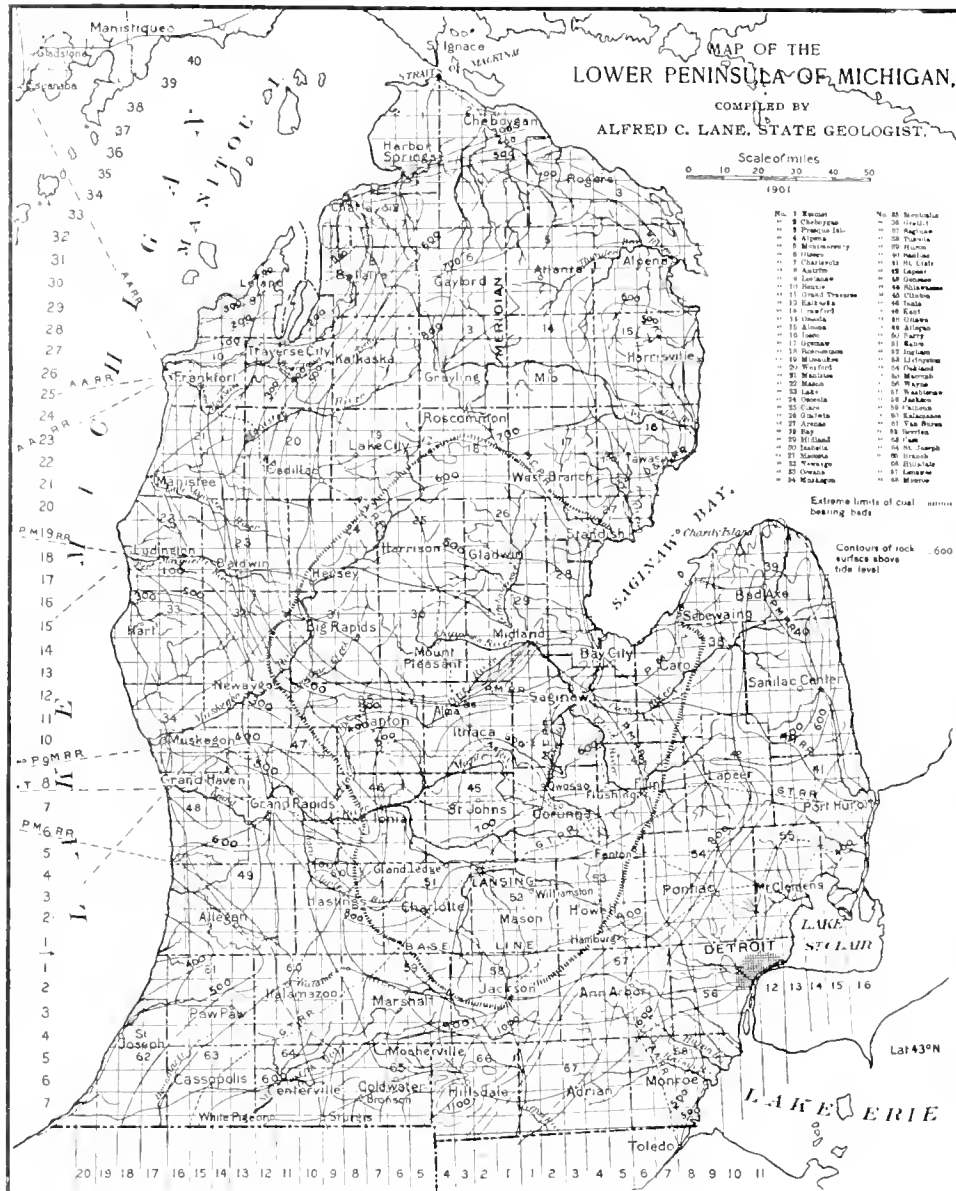

FIG. 1

beds places them in the Lykens Valley group of the Pottsville series. The reasoning he advances for his correlation (see Table) is that the fauna, flora, particular limestones (l. s.) and sandstones (s. s.) are indicative of the Pottsville and Lower Carboniferous formations in Pennsylvania, Ohio, and elsewhere.

Though the limestone underlying the coal series is equivalent to the Maxville in Ohio and the top of the St. Louis limestone of the Mississippi River, both being known as Lower Carboniferous rocks, the age of the coal beds cannot be directly inferred, inasmuch as there is a general unconformity between it and the beds. Some distance beneath the coal series there is a

sandstone known as the Napoleon or Upper Marshall which can be followed in outcrops or in drilled wells for about two-thirds of the coal basin. This bed is considered the equivalent

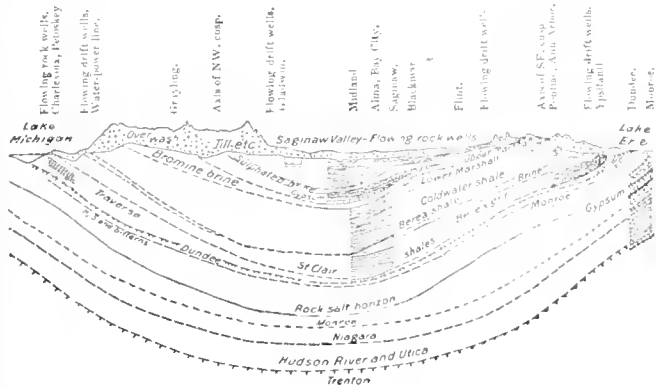

FIG. 2. CROSS SECTION, LOWER MICHIGAN BASIN

of the upper Logan of Ohio, and beneath it or outside of it no coal in commercial quantity has been found or is likely to be found.

CORRELATION TABLE

Pennsylvania	Ohio	Michigan
{ Lykens No. 1 coal	Tionesta	Upper rider coal
{ Homewood s. s.	Upper Mercer l. s.	Ligula shale
	Lower Mercer	{ Upper Verne coal or
	Massillon sandstone	Monitor coal
	Wellston	Lower Verne coal
Lykens Nos. 2 and 3	{ Jackson Hill	Middle rider
Conoquenessing s. s.	{ Quakertown	
	Massillon s. s.	Sandstone
Sharon conglomerate	{ Sharon coal	Saginaw coal
	{ Sharon conglomerate}	Lower rider
Lykens No. 4		Lower coal
Brookside		{ Lower beds toward
Lykens No. 5		center of the basin
Big Bed		
Lykens No. 6		

Mr. Lane finds that the beds decrease in thickness with depth, often being cut out entirely by erosion or replaced by sandstone, etc. Usually the beds above the coal are reported as black shales, and they are likely to be weak. Owing to erosion, coal is found at times directly beneath clay, sand, and gravel, or other unconsolidated rocks, where it is practically unworkable. Sandstone roof is a wet roof in this field and at several mines black bituminous limestone full of shells forms the roof. The floor beneath the coal is usually reported as fireclay or shale.

ANALYSES OF MICHIGAN COALS

	Lower Verne Bay County	Upper Verne Bay County	Saginaw Standard
Specific gravity.....	1.32		1.26
Moisture.....	8.71	3.78	10.67
Volatile matter.....	38.45	41.18	33.59
Fixed carbon.....	41.16	49.34	53.80
Ash.....	11.68	5.70	1.94
Sulphur.....	2.72	2.50	1.01
British thermal units	12,359	13,489	12,868

Minor undulations, known as "rolls" and "swamps," occur independent of the basin as a whole. In the swamps the coal is said to be thicker than in the "hog backs" or "rolls." Also in the swamps the coal is likely to be capped by a rider or thin seam. It will be noted in Mr. Lane's section that he has found it convenient to name the coal beds: Upper rider, Upper Verne, Lower Verne, Middle rider, Saginaw, Lower rider, Lower coal. The variations of these beds in this field are such that no one extends over the entire coal basin.

Michigan coal is not all of the same quality and is not all

poor. The Verne seams, white rather high in sulphur, are caking coals. Analyses of the Lower Verne, Upper Verne, and Saginaw coals, made by J. H. Williams, are given herewith.

SAGINAW VALLEY COAL MINING

In the Saginaw Valley the coal tipples are placed in level fields with no vestige of life about them and no buildings except those connected with the plants. Owing to this, the first impression of the visitor from other coal fields is that of loneliness, amounting almost to a feeling of desolation. There are good reasons for not having company houses, stores, etc. at these plants, which may be explained in a few words. The coal beds of the Saginaw Valley are not continuous, as in other fields, but are pockety; it would therefore be folly to construct a mining village and abandon it before the construction account had been wiped out; further, the surface is not owned by the coal companies, but by farmers, who till the soil. Most of the



FIG. 3. METHOD OF WORKING

miners live in towns nearby the mines and are carried to and from their work in special trains, in some cases at the expense of the operators and in others they pay a small fare. The Consolidation Coal Co., of Saginaw, has wash houses at its mines where the miners change their clothes previous to taking the trains or going into the mines.

The method of caring for the change house is somewhat different from that of other places, in that the miners hire and pay the wash-house attendant, thus making it feasible to have matters to suit their own convenience. It is the duty of the attendant to have water and towels ready when the men come from the mine; to see that the shift clothes are properly dried and aired over night; and to keep the house clean and neat.

The writer saw some of the miners leave the trains in Saginaw, and noticed that they resembled more nearly expert mechanics in their street clothes than miners coming from work.

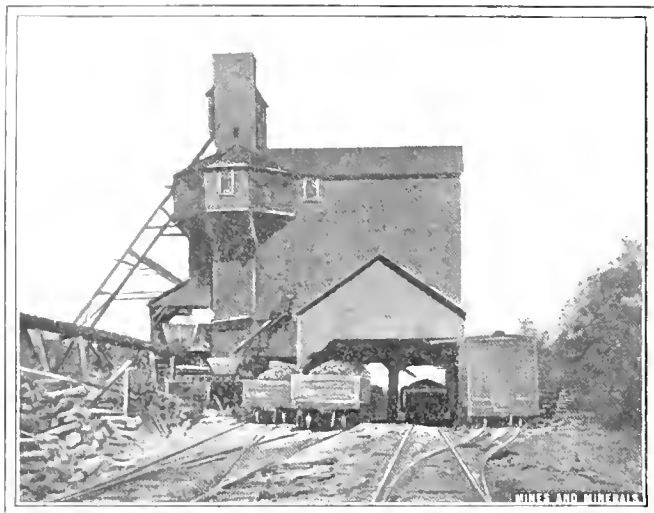

FIG. 4. RIVERSIDE TIPPLE

They are paid twice monthly, are most all English speaking, and have the air of satisfaction that goes with prosperity.

If, as is stated, the Michigan coal is not likely as an export commodity to enter into competition with coal in other states, the fact remains that it must be an excellent coal that can rob it of its natural market. Outside of the lower peninsula of Michigan little is heard of the Saginaw Valley coal, nevertheless a field that can produce 2,000,000 tons of coal, as this did in 1907, is no mean factor in the coal situation in lower Michigan.

The largest coal operator in the state is the Consolidated Coal Co., which operates nine mines in Saginaw and Bay counties and which has three more practically ready to commence operations. Two of their mines southwest from Saginaw are named the Riverside and Shiawasee. The former is near the Tittabawasee River, surrounded by trees with a mere trail for a wagon road leading to it; the latter is near the Shiawasee River, approximately 3 miles away from the Riverside. All operations in this vicinity are worked through shafts that vary from 165 to 185 feet in depth, showing that the coal beds are practically horizontal in this vicinity. There are numerous rolls in the beds, however, which make it necessary to do considerable dead work at times to keep the traveling roads at a uniform grade. Each mine has two timbered shafts to comply with the law, one for hoisting and one for escape in case of accident. The main or hoisting shaft has three compartments, two 6 ft. x 6 ft. for cages and one 2 ft. x 6 ft. as a pumpway. The head-frame is attached to the tipple, consequently the latter is practically over the shaft, a position which would be exceedingly dangerous were there no second shaft and were it not used as an upcast. Realizing this, the downcast is placed quite a distance from the upcast and is supplied with a blowing fan. The advantage of a blowing fan in this field is further enhanced by its preventing ice accumulating in the hoisting compartments during cold weather. In some cases the fans are driven by steam engines, in other cases by electric motors; in either case they are convertible into exhaust fans by changing a door. The air shafts, 8 ft. x 8 ft., are fitted with stairs having an angle of 45 degrees, so that in case of accident the men can

leave the mine without difficulty. All shafts are lined from the surface down, owing to the cover near the surface being unconsolidated material. As a rule the roof of the mines in the vicinity of Saginaw is slaty shale which flakes badly when exposed to the air; in places sandstone replaces the shale. The floor is usually fireclay but there are instances where the clay is wanting and sandstone forms the floor. While the coal bed varies in thickness from 2 feet 6 inches to 3 feet 10 inches, owing to rolls and swamps, a fair average would be 3 feet at Saginaw.

The mines are worked double entry with cross-entries driven in pairs at right angles to both main entries, as shown in Fig. 3. Entries are driven 18 feet wide with about 18-foot pillars between them. Cross or butt entries are spaced 300 feet apart, with 6-foot breakthroughs every 60 feet. For haulage purposes, entries are carried 5½ feet high, which makes it necessary to brush the roof and take up floor in the vicinity of Saginaw. The main entries are kept free from refuse while the cross-entries are used as gob entries in which to stow the waste. All traveling roads are timbered with posts and cross-bars to keep the slate from dribbling down on them. Pillar-and-room mining is followed in this field, it having proved better suited to the conditions which govern such matters, namely, a bending roof which will follow the mining. Room centers are 40 feet apart with rooms 30 feet wide. What appears peculiar to one accustomed to thicker coal beds, is the absence of a rib on the cross-entry side of the main entries where rooms are turned at right angles the same as from cross-entries and worked for 150 feet parallel with the cross-entries. This system is being abandoned, Mr. Andrew Stevenson, Mine Inspector of Michigan, informs the writer, and instead of only room-neck pillars being left on the main entries, a rib from 8 to 16 feet thick is substituted and rooms turned from the cross-entries.

Rooms are driven 150 feet long to meet those worked from the next nearest cross-entry beyond them. Breakthroughs, 6 feet wide, are made 30 feet in from the entry, for at this point the air is bottled up and becomes bad in such wide rooms. The next breakthrough is made 60 feet from the first, and as the rooms are but 150 feet long, only two are needed. Road-

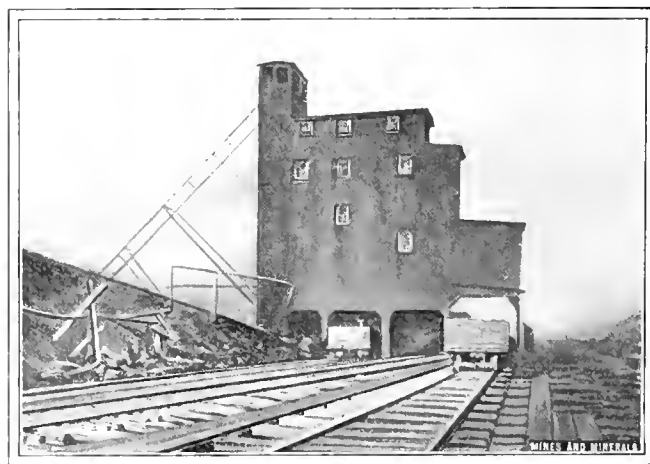

FIG. 5. SHIAWASSEE TIPPLE

ways are made through the center of the rooms and are timbered the same as entries, provided the roof requires such treatment. All undercutting is done by machines.

No undercutting is done with the pick, but considerable mining is done by shooting off the solid. Black powder is used almost exclusively, although some miners use dynamite in deep holes for the purpose of shattering the coal. For instance, a miner will put a hole in the solid face about 12 feet deep, then charge it with three or four sticks of dynamite and fire. The coal is not blown out but shattered so that it can be picked readily. This is termed "pick mining." Each miner drills, loads,

and fires his blasts just previous to leaving the mine; in this way the mine is kept free from powder smoke during working hours. When, however, the mine is not fully developed, shooting is practiced twice daily, but the men are not permitted to go back to their work until 3 hours have elapsed after firing. Fuse is used entirely for blasting, no squibs being allowed. With such regulations there are few accidents from powder. All mining is done on contract according to union scale, the miners being paid by the ton for all coal which passes over a $\frac{3}{4}$ -inch diamond-bar screen. The coal is blocky and hard, does not readily air slack, in fact favors block coal in physical appearance. Practically all coal is removed from the mine, and although the smallest sizes are mixed with slate and fireclay, nevertheless, when washed, they make excellent steam fuel. The miners hire the check weighman as in other places. Mules are used for gathering and delivering steel cars which, when loaded, hold about 1,000 pounds of coal. The miners push the cars from the entry to the room face and should the room exceed 150 feet in length they demand 3 cents per ton extra for their labor. From the partings the cars are hauled to the shaft in various ways. Head-and-tail rope, tail-rope, endless rope, and electric locomotives are in use. At the latest-opened mines, the shaft bottoms and partings are lighted by electricity and in such mines electric locomotives are adopted, provided the irregular conditions of the floor can be remedied without excessive cost. Where swamps are met water is generally found in these mines as elsewhere, and small electric pumps are employed to force it to the sump at the main shaft. Usually the quantity of water is not excessive, a steam pump with 6-inch column pipe being able to raise it to the surface. The advantages derived from using a steam pump in the main shaft are, that it aids ventilation and further assists in keeping the shaft free from ice in winter. Fig. 4 shows the Riverside tibble and Fig. 5 the Shiawasee. It will be noticed that they are enclosed and constructed higher than those in more southern latitudes. At first glance they resemble an anthracite breaker on a miniature scale, or a head-house at an ore mine. The arrangement and construction of these tipples is the result of experience, consequently they are well suited for their purpose. Self-dumping cages are used, and after the coal is riddled over the $\frac{3}{4}$ -inch bar screen it is weighed in a basket. From the basket it passes over or through shaking screens and is sized into domestic lump, steam lump, run-of-mine, stove, nut, and slack, before going by gravity to the cars.

The weather in Michigan is exceedingly cold in winter, which makes it a matter of necessity to enclose the tibble, as shown in the illustrations.

Because of the coal beds in the vicinity of Bay City being from 4 to 6 feet thick the output from a mine will be from two to three times as much as at Saginaw; however, the coal pockets not being continuous it is necessary to prospect thoroughly a piece of land with Keystone drills before any actual mining work is performed. After prospecting, calculations are made to estimate the tonnage and determine the amount of investment that the property will stand and yield a profit. Unless one is well posted practically on the conditions which prevail in the Michigan field there is very apt to be money lost in coal-mining enterprises; however, with the right men in the business there is money to be made, provided competition is not so excessive as to over supply the limited market for this coal.

來 來

Catalogs Received

ALLIS-CHALMERS Co., Milwaukee, Wis., Bulletin No. 1512, Compound Corliss Engines, 12 pages; Leaflet No. 2036, Sample Grinders, New "F" Gyrotory Rock Breaker, 4 pages; "Acco" Expander Ring, 8 pages.

AMERICAN SPIRAL PIPE WORKS, Chicago, Ill., Spiral Riveted Pipe, Lap-Welded Steel Pipe, Forged Steel Pipe Flanges, Hydraulic and Exhaust Steam Supplies, 20 pages.

ATLAS ENGINE WORKS, Indianapolis, Ind., Bulletin No. 201, Atlas Crude Oil Engines (Diesel Type), 36 pages; Report of Test of Atlas Crude-Oil Engine, by C. E. Sargent, M. E., 3 pages.

CLINTON WIRE CLOTH Co., Clinton, Mass., Special Catalog of Perforated Metals, 32 pages.

JOHN DAVIS & SON (Derby), Ltd., 110 West Fayette St., Baltimore, Md., Leaflet 113B, British-Made Magneto Exploders, pocket form.

THE GARDNER GOVERNOR Co., Quincy, Ill., Bulletin No. 142, Gardner Duplex Air Compressors Single and Two-Stage Belt, Steam, and Electrically Driven, 12 pages; Bulletin No. 163, Gardner Air Compressors for Stone Workers, 16 pages; Gardner Duplex Steam Pumps, 52 pages.

GENERAL ELECTRIC Co., Schenectady, N. Y., Bulletin No. 4838, Circuit Breakers Type C, Form K, 23 pages; Bulletin No. 4839, Circuit Breakers, Type C, Form P, 31 pages; Bulletin No. 4840, Circuit Breakers, Type C, Form G, 23 pages; Bulletin No. 4841, Circuit Breakers, Type C, Form Q, 4 pages; Bulletin No. 4842, Circuit Breakers Remote Control, 18 pages; Bulletin No. 4843, Magnetic Blowout Circuit Breakers, Type M, Form K, Form K 3, Form L-2, 10 pages; Bulletin No. 4849, Motor Generator Sets, 20 pages; Bulletin No. 4866, Thomson Horizontal Edgewise Instruments for Switchboard Service, Types H and DII-2, 16 pages.

GARDNER CRUSHER Co., 556 West 34th St., New York, N. Y., Gardner-Crusher Disintegrator and Pulverizer, 12 pages.

THE GOULDS MFG. Co., Seneca Falls, N. Y., Bulletin No. 102, Single-Acting Triplex Plunger Pumps, 12 pages.

HAYTON PUMP Co., Quincy, Ill., High Efficiency Turbo-Centrifugal Pumps, 16 pages.

HARRIS AIR PUMP Co., Indianapolis, Ind., Pumping Water by Compressed Air, 14 pages; Compressed-Air Pumping, Harris Twentieth Century Air Lift System, 55 pages.

McKIERNAN-TERRY DRILL Co., New York, N. Y., Core Drills for Prospecting, Testing, Blasting, etc., 68 pages.

GEORGE M. NEWHALL ENGINEERING Co., Philadelphia, Pa., The Engineers Reference Book and Vance Steam-Trap Catalog, 63 pages.

NILES-BEMENT-POND Co., New York, N. Y., Heavy Lathes, 27 pages.

WEBER SUBTERRANEAN PUMP Co., 90 West Street, New York, N. Y., Weber Subterranean Pump for Artesian Wells, 4 pages.

來 來

Obituary

FRANCIS L. ROBBINS

Francis Le Baron Robbins, of Pittsburg, Pa., the promoter of and for several years president of the Pittsburg Coal Co., died at Chicago, on September 8, in the fifty-seventh year of his age. He was born at Ripon, Wis., but in boyhood removed to Pennsylvania, where his father had entered into the coal-mining business with the late John Arnott. As a mere boy he entered the employment of the firm, and before he reached the age of 21 he was superintendent of the Pittsburg and Walnut Hill Coal Co. Later he organized the Robbins Coal Co. and the Willow Grove Coal Co., and still later he became financially interested in the Pittsburg Consolidated Coal Co. In 1899 he succeeded in consolidating a large number of mines in the Pittsburg Coal Co. and his management of the company, in spite of several adverse circumstances, was a successful one.

He retired from the presidency of the Pittsburg Coal Co. in 1906, and for a year thereafter was president of the Monongahela River Consolidated Coal and Coke Co. He retired from the latter position on account of ill health.

Mr. Robbins was active in politics, and he was prominently mentioned as a successor to the late M. S. Quay, as United States Senator from Pennsylvania.

Conservation of Minerals

The Contribution of the Mining Profession to the Conservation of Our Natural Resources

Dr. Henry S. Drinker, the able President of Lehigh University, in an address delivered, in August, at the exercises commemorating the twenty-fifty anniversary of the Michigan College of Mines, reviewed and summarized what the mining engineering profession has done in the last generation for the conservation of the natural resources of the country.

He first called attention to the fact that in a report made in January, 1869, to the Secretary of the Treasury, on "The Present Condition and Prospects of the Mining Industry," Dr. Rossiter W. Raymond foreshadowed the lesson of economy in the development of our mining resources, when he spoke of "the protection of the country against reckless and wasteful mining, by the inculcation of sound principles, and the enlightenment of the miners as to their best interests." Continuing he said:

"It is a fact not generally known or appreciated that this matter of the need of conservation of our natural resources, particularly of our mining and timber resources, to which the general public is only just awakening, has been the subject of careful study and outspoken warning by our engineers for years, and there is no body of men who have contributed more valuable knowledge and suggestion in this matter than the American Institute of Mining Engineers, founded in May, 1871. This society of engineers has done incalculable good in the last 40 years in developing technical knowledge, research, and discussion by its meetings and publications, and in its history, the Institute, beginning with the notable discussions on 'Waste in Coal Mining' and on 'Technical Education' in the early seventies, up through the succeeding years, has taken leadership in the consideration and study of many important matters pertaining directly to conservation and engineering education."

He called attention to the fact that, at the first meeting of the Institute held in Wilkes-Barre, Pa., in May, 1871, which he, as a young engineer, attended, a committee was appointed "To Consider and Report on the Waste in Coal Mining." This action followed the presentation of a thoughtful paper on the subject by the late Richard P. Rothwell, in which, even at this early period, the waste resulting from mining under short-term leases was referred to as follows:

"The system of leases under which the operator pays for coal shipped, but not for coal wasted, and for the larger sizes frequently a larger royalty than for the smaller sizes, greatly aggravates the evil. When the leases are, moreover, for short periods, the combination of conditions is most mischievous. It then makes no difference to the lessee how much coal is wasted or left in the ground. His efforts are directed to getting to market as much coal as possible of the most saleable sizes in the given time."

Mr. Rothwell's statement was practically repeated in a paper read by Mr. John H. Harden, at the Boston meeting of the Institute, in February, 1873, when he said:

"It has been said that lessees have not the opportunity of making the best of the mine for themselves or the owner, owing to the short period over which their tenure frequently extends; this should be remedied; every facility consistent with the proper working of the mine should be given, nothing reasonable withheld, as on the lessee rests the greatest share of contingencies and risk."

The Institute's Committee presented a preliminary report at the second meeting of the Institute held at Bethlehem, Pa., in August, 1871, in which valuable recommendations were made. It was found as time went on, that the work started by the Institute Committee required the authority and backing of the State for its successful prosecution. Largely through the efforts of the late Eckley B. Coxe, the Legislature of Penn-

sylvania, in 1889, passed an act creating a "Coal Waste Commission." Mr. Coxe, who had been chairman of the Institute Committee, was made a member of this Commission and became its chairman, and the Commission made a valuable and exhaustive report in May, 1893. In discussing methods of mining the Commission made this wise comment:

"It is one of the best evidences of engineering skill when the coal that must be sacrificed is determined and deliberately set apart for that purpose at the time the colliery is opened out, or very soon thereafter," and in commenting on "Avoidable Waste by Mining," they said:

"When any given territory is to be worked, a much larger percentage of coal can be gotten out if the conditions in which the coal occurs are carefully studied, and a general system of working decided upon and thoroughly carried out from the beginning."

Doctor Drinker comments on these views in the following rational manner:

"How obvious it is that these wise suggestions can only be carried out when the mining operations are conducted on a large scale, with ample capital, under conditions of actual ownership or under leases of such long term as will financially justify such a plan of working, and that they would be impracticable where mining is to be pursued in small operations with limited capital where speedy returns must be exacted on the capital invested."

He also referred to the valuable papers presented at the joint meeting of the American Society of Civil Engineers, the American Institute of Mining Engineers, the American Society of Mechanical Engineers, and the American Institute of Electrical Engineers, held in New York, March 24, 1909, to consider the matter of the "Conservation of Our Natural Resources." At this meeting Doctor Raymond read an admirable and exhaustive paper on "Conservation by Legislation," which among other subjects dealt with the conservation of coal. Later Mr. Edward W. Parker, Statistician in charge of the Division of Mineral Resources of the United States Geological Survey, read at the Spokane meeting of the American Institute of Mining Engineers, in September, 1909, a paper on "The Conservation of Coal in the United States."

Quoting from Doctor Raymond's paper, Doctor Drinker said:

"I remember well what Eckley B. Coxe said to me, that salvation for the anthracite region, and its store of natural resources, lay in the control of the collieries by capitalists who had other aims than immediate profit from the coal; and that the acquisition of such control by great railway companies, whose interest it was to make anthracite the basis of a profitable freight business for generations to come, was not only the best, but the only remedy for the reckless and the irreparable waste which the system of 'hogging' the mines under short leases had brought about."

Doctor Raymond further added (speaking of Mr. Coxe's prediction):

"The results verified his prophecy. The great railway companies operating the anthracite collieries have put more money into preliminary deadwork and costly machinery; have been the pioneers of rational forestry for the provision of permanent supplies of mining timber; have enforced economy in every department of production; have trained and employed the most skilful engineers and experts; in short, have redeemed from immediately impending rack and ruin the whole anthracite industry."

Quoting from Mr. Parker's paper, Doctor Drinker said:

"Most of the members of the Institute are cognizant of the suits brought by the Government against the anthracite operators in Pennsylvania, or the combination of interests commonly known as the 'hard coal trust.' No defense of any illegal combination in restraint of trade is intended, but there are some facts which should not be lost sight of; and unfortu-

nately those whose opinions are based upon the 'news' given to us by the daily press are likely to be governed by *ex parte* testimony. The present situation in the anthracite region is one that has been developed through sheer necessity, if the conservation of the supply of anthracite and the prolongation of the life of the fields in the best interests of the people were to be attained in any other way than through government control, and government control did not seem to be materializing. I believe that even Doctor Raymond will subscribe to the statement that a good part of the history of anthracite mining has been one of profligate waste in the mining, preparation, and use of that precious supply of fuel; and this has only been remedied, none too soon, and could, under the circumstances, only be remedied by the close control and conservative management which have been brought about in recent years. And I might pause here to pay a merited tribute to such men as Doctor Raymond, Eckley B. Coxe, P. W. Sheaffer, Franklin B. Gowen, William Griffith, and a few others through whose efforts many reforms which lessened the waste of anthracite were effected. They were the pioneers in the battle for conservation, and a monument should be erected to them.

"The securing by the Reading Railroad for its offspring, the Philadelphia & Reading Coal and Iron Co., of the great coal reserves it owns today, was the beginning of a great movement which was foreseen by those in a position to see. The Reading company was temporarily bankrupted through its guarantee of the debt thus incurred, but the possession and control of those coal lands are indirectly the most valuable assets of the railroad at the present time. More than this, however, in the ultimate economy of things, has been the preservation of thousands of acres of coal lands from reckless spoliation. The way was paved for the safe and sane control of the anthracite industry, albeit by a trust, and a stop was put to the cut-throat competition and extravagant methods which in earlier years had resulted in losses of millions of dollars in money and more than millions of tons of coal.

"Under former conditions in the anthracite regions, when it was not considered necessary to give thought to the morrow, and indeed up to the time when the Anthracite Coal Waste Commission made its report, it was estimated that for every ton of coal mined and sold 1.5 tons were lost. The greater part of this loss was in the coal left in the ground as pillars to protect the workings, while millions of tons of small coal or screenings were thrown on the culm banks which now form unsightly mountains in the coal regions. Improved methods of mining and of preparation have of late years reduced the percentage of waste, so that at present the recovery will average about 60 per cent. and the loss about 40 per cent. *** A careful study of conditions in the anthracite region will convince the most skeptical that no robbery of the public is now being carried on."

In expressing himself Doctor Drinker said:

"In view of the rather superficial utterances that have been put forth during the last year or so on the general conservation question, it would seem to be the duty of engineers to keep in touch with this matter, and to do their share toward shaping the policy of the Nation to a course based on reason and technical knowledge, rather than on sentimental diatribe. I think that a greater danger today to the public interests is threatened by the untrained, spasmodic, semipolitical and careless presentation and handling of these matters before the public, by men on whom their importance has suddenly dawned, than even by a continuance of the wasteful methods of the past.

"It is dangerous for a man untrained in engineering to venture opinions on questions like the conservation of coal and the development of water-powers, which require the judgment and experience of engineers. The trouble with many of the plans for coal and water-power conservation proposed by men untrained and inexperienced in engineering and in business methods, is, that their plans are ideal rather than real;

their dicta negative rather than positive, and their remedies theoretical rather than practical. You have doubtless observed that the fear that is uppermost with such men is often rather that our public resources will pass into the control of what they term the 'monopolistic interests of the few,' than the crucial question of what is the best plan or system for the economic winning of our natural resources in the interest of the public. What engineers should urge and impress upon the public mind is the importance of looking at these industrial questions in a wholly cold-blooded, business way—without any obsession or oppression of undefined hysterical fear of the results or dangers of a so-called corporate monopoly that are often as visionary as the nursery tales of bogies to frighten children into being good. Corporations, as we know, are, as a rule, only aggregations of capital to promote some useful industrial or transportation purpose; they are, like other agencies of the day, capable of use and of abuse. Strychnin is a virulent poison used ignorantly, or for an evil purpose, but it is a valuable medicinal remedy in the hands of the physician; and under the recent broad decision of the Supreme Court the reasonable function of the large corporation has been defined. Attorney-General Wickersham in his recent address at Hancock (across the bridge), in this state, summarized this in a few pointed words when he said (in reference to the Sherman Act):

"But when the Supreme Court said we must read this statute as reasonable men and give it an interpretation that will not strangle all trade, but which will prevent any undue restraint, prohibit all contracts and combinations that are intended to interfere with the natural course of trade, then the court gave us a means of preventing those evils which led to the enactment of the law."

"In taking wise and broad measures to avail best of our undeveloped natural resources, the need is not so much to withdraw and set them aside for the use of future generations as to be sure that they are not wasted in their use by the present generation. Let our natural resources be utilized, following the natural laws of supply and demand, with due regard to the essential factor that private capital will never venture into the proper, broad, economic exploitation of these resources without the assurance of a sufficiently permanent tenure to insure an adequate return. And let us give due recognition to the thought that conservation may be overdone by the undue and unwise stimulation of such popular demand for drastic control that we may dwarf the business development of our present and coming generations by conserving resources now urgently needed, especially in Alaska and in the West, only to set them aside for the needs of an indefinite future when other agencies may have been found to take their place. Do not let us be blinded or misled by the fears of the uninformed, or by what is equally dangerous, the narrow view of the partially informed, who fear industrial dangers they have never actually faced, and preach a crusade against evils that are so theoretic that practical men know them to be imaginary.

"The difficulty, and the probable error, in criticizing all large development enterprises as being so-called monopolies, is that the superficial critic is apt to consider and discuss the situation on one side only. The conservation—the careful mining—of our coal, and the economic development of our latent water-powers, for instance, can only be managed properly by the investment of large capital, and this can today be supplied only by the association of many individuals, having capital to invest, into large corporations controlling such aggregate capital, or by the Utopian plan of state or federal ownership and the use of the public funds in an industrial enterprise. As to corporations, the stronger they are the more surely are they in a position to handle the mining problem conservatively and economically. The economic mining of coal—the proper development of a water-power site, involve purely expert questions, but it takes capital to command the best expert talent.

"The question—the practical question—is, how is the public today—how are our future generations, to be best benefited by conservation? It would be nonsensical to say that we do not wish our coal, or our water-powers, to be leased to, or availed of, for the present generation, simply because we wish to preserve them for future generations.

"The question is whether the present generation needs these resources: if it needs them, the need is exactly that which would be supplied were they held for succeeding generations. It seems to me that the main thing to be guarded against is that the natural resources still in the ownership and possession of the national government shall not be so disposed of that they can be acquired at a comparatively low price now, to be held wholly speculatively, for development in an indefinite future; surely this can easily be guarded, because there are few corporations who can command large sums of money to be locked up for a return a century hence. Stockholders want a quicker return for their money. But again, how easily this principle can be distorted or misapplied by an honest but narrow and inexperienced enthusiast; for any large enterprise must be enabled to acquire a sufficiently large body of coal, or a sufficiently long lease of water-power, to at least secure a sinking fund return on capital subscribed or borrowed. Proper conservation of our natural resources does not mean throwing open their exploitation to the wasteful methods and inexperienced handling of individual operators with the unnecessary duplication of plants and the waste of capital involved in uneconomic individual operation. Conservation of our natural resources does not mean the conservation of the individual operator. As a rule it points to reasonable cooperative effort lawfully exercised in the interest of that economy in methods resulting from operating on the larger scale that conserves our resources for the benefit of the consumer and prevents their waste by the producer. Much of the twaddle that is talked and written arises from a sentimental sympathy for the individual operator who is often the worst enemy of true conservation. As a rule there is no more wasteful system of mining than that pursued by the small individual operator. The man who owns, or leases, a small mine, or who leases a large mine for a limited period, on limited capital, is almost certain to mine extravagantly. He absolutely must get all he can out of it in the cheapest way possible. He is not concerned with laying out deadwork ahead—with planning far in advance so as to take out the largest possible amount of coal or mineral in the most economical way. He has the power, within certain bounds, as a rule, under his lease, to so operate as to get the largest amount out of the mine in the cheapest and quickest way possible, practically regardless of the waste in mining. Moreover, the small individual operator is, as a rule, absolutely indifferent to the interests of the public, whereas a large corporation, doing business not for a limited term, but for time, must so conduct its business as to be content with a moderate and reasonable profit on a product mined economically, and with a far-seeing eye to the conservation and avail of all its resources, and to the just treatment of its customers.

"These suggestions as to the individual operator apply equally to small corporations not possessing sufficient capital and strength to mine economically and with an eye to the future.

"When we talk of large aggregations of capital it is well to consider the good they have done, and can do, with the apprehended evil. It will not do to assume broadly that what is misnamed the 'monopolizing' of our coal interests, for instance, results in waste of our natural resources and in injustice to the public.

"Perhaps one of the best summaries of this great conservation question now before our people, and in which the engineering profession is so interested, and in regard to which our mining profession has so great a duty to perform, was given by Dr. C. W. Hayes, Chief Geologist, of the United States Geological Survey, in an address some time ago at the University

of Chicago, when he defined conservation as 'utilization with a maximum efficiency and a minimum waste,' and said:

"The reform that is needed through the country as a whole must gain its motive power not from sporadic instances where true business methods prevail, or from the well-intentioned enthusiasm of the few, but from the well-informed intelligence of the many. The campaign for conservation must be one of education.

"There appears to be an unfortunate confusion in the minds of certain advocates of conservation. They have apparently confused conservation of natural resources with destruction of the trusts, and the mixture has resulted in pure demagoguery. * * * Any one who has studied conditions attending the development of mineral deposits must have been impressed by the fact that those deposits held by large companies are being developed and utilized with a view to prevention of waste, in accordance with the principles of conservation, to a much greater extent than are the deposits held by small companies or by individuals.

"This matter, particularly in connection with the prospective development of our coal in Alaska, was gone into quite fully in the 'Investigation of the Department of the Interior and of the Bureau of Forestry' by the Joint Committee of Congress (the Pinchot investigation), and Mr. George Otis Smith, the Director of the United States Geological Survey, in testifying before this Commission, said:

"Take the condition of the anthracite regions. As I understand it, the present conditions—we are talking from the standpoint of conservationists—the present situation, where large interests more or less control the whole field, is much preferable to the former condition of a large number of small operators who only took out a part of the coal and wasted more than they took out.' And again in his testimony he said: 'It is not monopolization that is the conserving agent, it is not the monopoly that conserves: it is the large unit that conserves. And I should say that the operation of the coal mines by the large and strong interests which control also the railroads in a given field would be a conserving practice, because it would involve large units. * * * I want to see the Government, by law, control the large unit. There is no use of arguing for the development of large units in industry, unless at the same time the control of the large units is given to the Government. But the large unit in itself is the thing to be sought. The day is past for small operation in any industry of this country, and if we wish to bring back the old conditions, and which still persist; if we wish to encourage the existence of small operations which mean nothing but wasteful competition, I think we would be working directly against the operation of natural law and I do not think that natural law ought to be opposed either by executive order or by legislative enactment.'"

采 采

Raise Goats on Coal Lands

A new companion to the coal miner threatens to butt in, in the person of the festive goat. Last year over 14,000 of these animals passed through the Chicago slaughter pens.

At any rate, goat culture is now an attractive proposition from the money making, if not the gastronomic standpoint, and capital is giving it attention. The matter is receiving the favorable notice of mine owners. Thousands of acres of coal lands are scrubby and declivitous hillsides, unsuited for agriculture. Goats will graze on shrubs and climb the steepest hills, where nothing else can live. They defy dogs and are of anti-race-suicide principles, in a marked degree. It is announced that the experiment of raising goats on waste mining lands is to be given a trial. If it works out with profit the plaintive bleat of Nanny and the playful antics of Billy in trying to take a fall out of other creatures that cross their paths, will be familiar to coal-mining regions generally. No other form of industry is so wasteful as that of mining.

Underground Safety Appliances

Protection of Shaft Bottoms, Haulage Appliances, Electric Wires, Stables, Rope Crossings, Etc.

By Stephen L. Goodale*

In the September MINES AND MINERALS, the various safety appliances and regulations in use at the mines of the H. C. Frick Coke Co. were described. The care shown in choosing and adapting means for the prevention of accidents continues into the mine itself. A number of the devices employed underground will be described, and finally the scheme of working, to which we may refer in connection with systematic timbering.

Emphasis has already been laid upon the fact that prevention of accident is the end sought, and much less attention is given to provision for accident. Even of the latter, however, care has been taken, as will be outlined. As the President of the company says "the oxygen helmet apparatus and first aid to the injured are all right in their place; but spending so much time on them rather than changing the conditions in and about the mines to prevent accidents is like putting the wagon before the horse. The thing to do is to prevent accidents."

The shaft in a mine is a dangerous place, where many accidents occur. Any means to lessen the danger of working in or near the shaft is a matter of much importance in mining. The fence about the top of the shaft has been described; in these mines, the bottom of the shaft is shut off from the haulageway by a gate. This is operated automatically by the cage in such a way that when the cage is not at the landing the gate is there. As the cage approaches the landing it engages a device which raises the gate out of the way. It will thus not be possible for any person to get into the hoisting compartment except when the cage is ready to take passengers. These gates, shown in Figs. 1 and 2, need no further explanation.

Considerable small coal drops from the wagons in hoisting and finds its way to the shaft bottom and must occasionally be cleaned out. The shaft is generally but a few feet deeper than the level of the landing, and were a cage to descend while a man is working in the shaft he would almost surely be killed. A heavy chain is hung across the shaft between the timbers and across both compartments of the shaft; the cage is then allowed

to descend and rest its weight on this chain, and then only is a man allowed to enter the shaft and to shovel out the accumulation of coal there.

The arrangement for handling men at some of the shafts is very good, indeed. For instance, at the Leisenring No. 1, there is a waiting room just beside the hospital room near the shaft, the gate to which is locked and the key carried by the

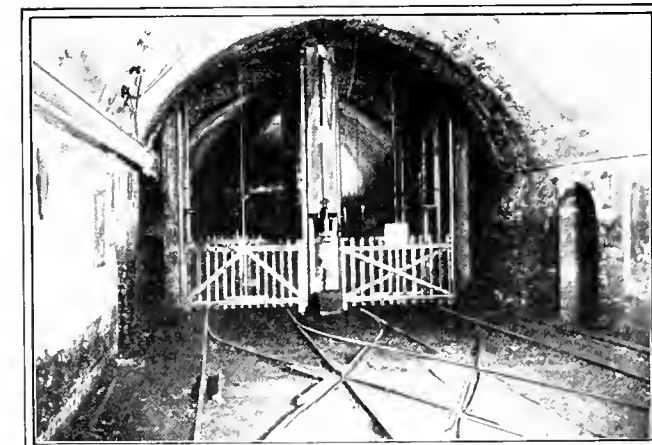

FIG. 2. GATES CLOSED AT SHAFT BOTTOM

one cage load of men is allowed inside the fence at one time, thus preventing crowding at the cage. There is set somewhere in the track approach to the shaft a derailing switch, simply one rail that can be thrown over to make a break in the track. The shaft is kept free from high-pressure water or air pipes in the more recent mines, these being provided for by special bore holes. The cages are provided with the usual dogs to catch in case of a failure of the hoisting rope, and each cage has two hand rails at a convenient height for men to steady themselves by.

The air-shaft is inspected every day, a different man each day. At Continental No. 1, for instance, at present the inspection is as follows: Monday, Fireboss Barton; Tuesday, Fireboss Moore; Wednesday, Fireboss Hirnornski; Thursday, Mine Foreman Jim Moore; Friday, Head Carpenter Pierce; Saturday, Machinist Griffith. This makes sure of a very careful inspection each day, for no man would want to be caught in an oversight of failing to notice some dangerous condition. The men also inspect the fan. The fans are usually run as pressure fans to blow air into the mine; but the housing is so arranged that with very little trouble they can be changed over to suction. Gates at the fan house prevent any one from reaching the air-shaft except when necessary. The ladders in these shafts are made and placed so that it would be possible for a man to climb out of the mine without any light if necessary.

Article 2 of the rules and regulations of the company states the amount of air required for ventilating, and it is twice the amount demanded by the state law. In addition, the efficiency of ventilation is very high; that is to say, of the amount of air blown in, a very high percentage is actually received at the working places. An anemometer is used for the measurement of the air-current, and the air velocity and cross-section of the heading is measured. At the Continental No. 1 such readings are taken once a week at 14 places, inlet and outlet to the mine, at the entrance to each section of the mine and at the last cross-cut in each section in accordance with the state law. A check measurement is made once a month also.

Rope haulage, compressed-air locomotives, or electric locomotives are used in the different mines in addition to animal power. Each kind of haulage requires certain safeguards of its own, as well as the care necessary in general for any underground transportation of large tonnages.

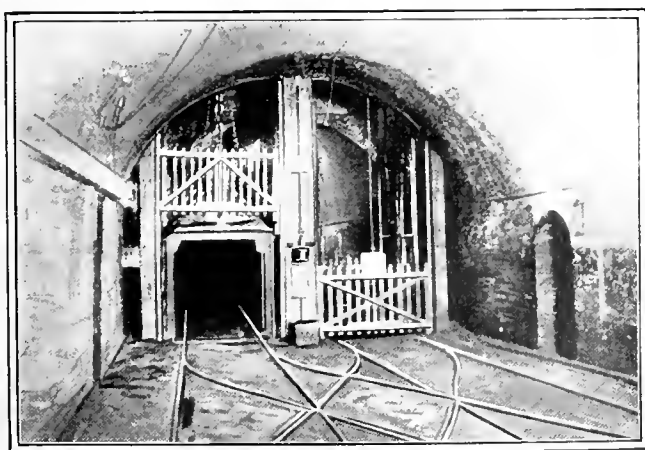

FIG. 1. CAGE AT SHAFT BOTTOM, GATE OPEN

to descend and rest its weight on this chain, and then only is a man allowed to enter the shaft and to shovel out the accumulation of coal there.

The arrangement for handling men at some of the shafts is very good, indeed. For instance, at the Leisenring No. 1, there is a waiting room just beside the hospital room near the shaft, the gate to which is locked and the key carried by the

* Professor Mining University, Pittsburg.

In the system of tail-rope haulage it was formerly necessary for a man to ride on the front end of each trip in order to release the rope at the proper point, as shown in Fig. 4. Andy Horn while on this job devised a hook catch for the rope so that the rope could be disengaged by the engineer simply letting the rope slack off when he wished to release the trip. The rope then drags on the track and slips off the hook. This arrangement is shown in Fig. 5; and Fig. 4 shows that riding the trip was not a safe occupation.

Where electric haulage is in use the trolley wire is protected by boards supported from the roof as shown in Fig. 3. These strips extend well below the wire on one side in an ordinary haulageway and down on both sides of the wire at any crossing where the wire might be touched on either side. This is necessary because of men carrying tools over their shoulders and because the neck and shoulder seems to be a particularly vulnerable point of attack for an electric current.

When compressed-air haulage is in use, recharging stations must be arranged for so that the locomotives shall always be within reach of such a station from the last one. The pipe at these stations is set on very heavy timbers, and the valve set with a handle extending behind these timbers to protect the man who is setting the valves from any accident, such for example as not closing a valve properly which might cause a pipe to fly about when released, etc.

Repair rooms for locomotives are built with the floor about 2 feet below the track level so as to afford access readily to the under parts of the machine. The roof may be arched and stirrups hung from a girder bent to the arch section and built into the top part of the concrete or masonry of the arch. Chain blocks suspended from these stirrups may be used to lift any part of or even the whole locomotive if necessary.

A visit to the stable is one of the most interesting things in an inspection of one of these mines. The stables are built either with an arched roof of masonry or concrete or with a roof supported by steel beams placed about 4 feet centers and covered with a lagging composed of slabs of reinforced concrete 4 ft. x 2 ft. and of a thickness of 4 inches or more as necessary at any particular place. In one stable the only wood used is a strip along which to carry the lights and a box for the curry

combs. Everything else is metal or concrete, such as the feed boxes which are concrete, the swinging pole between two horses which is a 2-inch pipe. A large concrete watering trough (said to be built without any reinforcement) is set in a large stall adjoining the stable, and here the horses are washed off with the hose when they come from work. Lengths of hose are kept at both ends of the stable and several fire extinguishers are also kept in readiness for use. The stable floor is brick, draining to one end for convenient cleansing. There is a steel door at each end of the stable. The ventilation is under perfect control. Hay is brought into the stable baled and not loose, being usually brought down in the fire-proof steel wagon. In Fig. 6

is shown one of the stables, although a little more wood is used in this particular place than mentioned above, the swinging poles being of wood. It is unfortunate that it is not possible to have the horses in this view, for it would be difficult to find in any industrial stable a finer lot of animals, but it would scarcely be safe to ignite a flashlight with the horses there for fear of frightening them.

At the Continental No. 1, where an endless-rope haulage is used the rope crosses a man-way at one point, and Fig. 8 shows the crossing which is just like an old fashioned country stile. At one side

is a bull wheel around which the rope is carried and there is a railing along this side of the stile.

Switches are operated as far as possible with a long lever set back in a niche in the wall with room enough for the man operating the switch. Where it seems to be necessary or advisable, spring car stops are placed on the track, which operate to stop a car unless they are opened by hand. In the main landings where possible the flooring is built up on a level with the tops of the rails; or where this cannot be done conveniently the narrow place between the rails at a frog is filled with a plank to prevent a man or animal from being pinched there and held. Sharp corners between haulage roads are built up of concrete piers to prevent squeezes, the concrete used consisting of coke ashes, slate, and cement.

The clearance along tracks on all haulageways is 3 feet, which is twice that demanded by state law. This clearance is kept uniformly on one side of the track, and is indicated by having the wide side whitewashed, as shown in Fig. 8. In

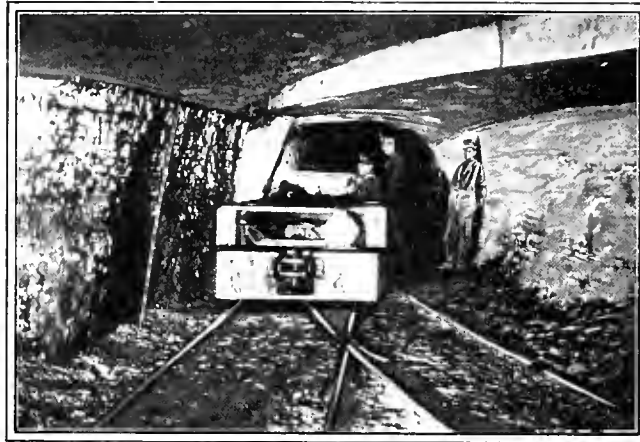

FIG. 3. PROTECTION OF TROLLEY WIRE

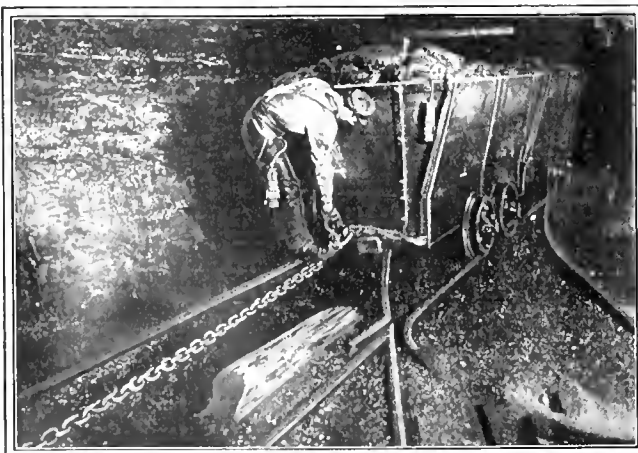

FIG. 4. OLD WAY OF RELEASING TAIL-ROPE



FIG. 5. NEW ARRANGEMENT FOR RELEASING TAIL-ROPE

addition to having the wide side, recesses are cut into the wall at this side at regular distances apart and whitewashed.

In connection with a plan like this it is well to note that unless it is absolutely uniformly carried out through any mine it may become a source of danger. If in most places in a mine there is this clearance but it is lacking at a certain part of the mine, a man accustomed usually to the safety is very apt not to be careful in the dangerous place.

Signboards are placed at many points throughout the mines directing the way to manways, to the shaft, or to other parts of the mine, so that a person could find his way out of the mine by means of these signs. Other signs are also posted indicating places where there is special danger, being painted with white letters on a red background—the directional signs being white letters on a black background. Dangerous portions of the mine are fenced off, also abandoned workings, so that miners shall not wander into the same.

At the Continental No. 1 is an interesting crossing called "The Jim Moore Arcade." It was necessary to cross a haulageway to get from the manway at the landing of the shaft. To avoid having the men continually crossing this busy haulage, a drift was cut through the rock over this haulage so the men can pass in safety; and while, at present, this passage debouches upon the landing directly on the return track for empty cars about 2 feet below the landing proper, it is probable that the arcade will be extended over this empty return track to the main landing.

At all underground engine rooms, pump rooms, etc., where necessary, there are similar guards on the machinery to those described on the surface.

A number of points of technical interest might be described but that is not within the scope of the present paper. The pump lines and high-pressure air lines are carried from the surface into the mine through special bore holes, the pipes themselves being encased in cement, in the case of air pipes to protect the pipe, and in the case of water pipes so that the concrete itself shall form a pipe when the acid waters have eaten out the original column. Permanent brattices are built up solid either of brick or with concrete made of slate from the mine and sand and cement brought in from the outside.

This company established the first rescue and first-aid station in the bituminous coal fields of the United States aside from those established by the government. Three such stations are now maintained; that at the Leisenring No. 1 mine has now graduated more than 100 men. Each man is given 12 lessons, the first of ½ hour, then six lessons of 1 hour each, three of 1½ hours each, and three of 2 hours. The practice chamber is fitted up to represent a mine and kept full of poisonous gas so that the helmets are necessary for use in the chamber. The usual sort of practice work is given. Now the men are to be trained to team work to make them more efficient and also to keep them in practice. A certificate is issued to each man on completion of the course, and a card also which is required to enable any man to use the oxygen helmet at a time of accident.

Important as this rescue work and the appliances are, however, it is of far greater importance to keep everything about the mine so that they will not be needed. The prevention of accident will do far more good than a lot of rescue work carried on after accidents have happened.

One reason for the great increase in the number of accidents in late years is that operators have probably not made changes in their methods of operation to meet the

changed conditions of mining. When mining in the drift mines with no shaft or hoisting, and the workings shallow and open practically direct to daylight, the problem of ventilation is very simple. Usually there is no gas to contend with, and enough surface water soaks in to prevent dry dust and awful dust explosions. The problem of gas is felt today to be thoroughly under control, requiring sufficient ventilation, requiring that old workings and gobs be swept free of gas, requiring frequent tests in order to know of its presence and amount, and all this can be handled by controlling the air-currents so that they shall travel where required and be of sufficient volume. In all gaseous mines safety lamps can be used, and lamps are now available which are really safe. The great volume of air blown into the mines is warmed simply by its passage through the workings; therefore, it takes up very large quantities of moisture, constantly drying out the walls, roof, and floor of the passages, and thus the quantities of fine coal which accumulate and are con-

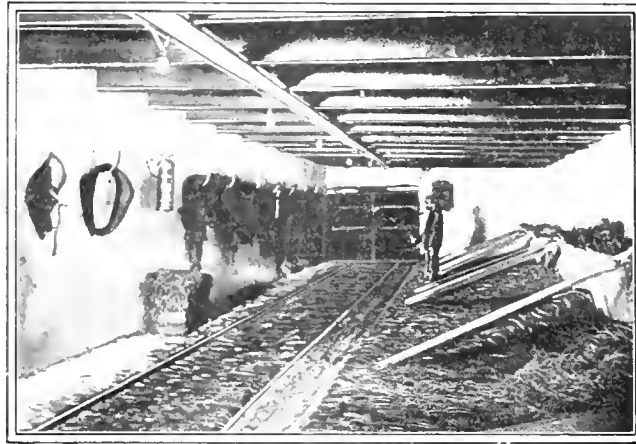

FIG. 6. UNDERGROUND STABLE, H. C. FRICK COKE CO.



FIG. 7. CROSSING OVER HAULAGE ROPE

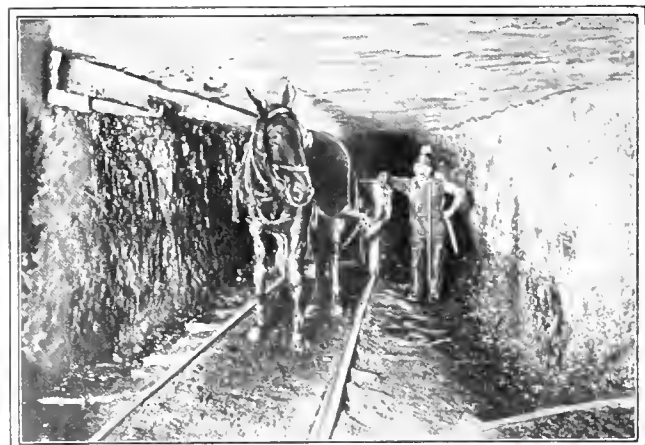

FIG. 8. SHOWING CLEARANCE ON SIDE OF GANGWAY

constantly subjected to this drying become dry and dusty, and the problem of dust is a most serious one. In mines that show this drying tendency the Frick company place fine sprays in the airways where the air may take up additional moisture to correspond with its increased temperature in the mine and so prevent this drying. The air in its return from the working places is passed along the fracture line mentioned later, and so the gas is kept washed down off the gob. Overcasts for the carrying of an air-current across some entry are substantially built as

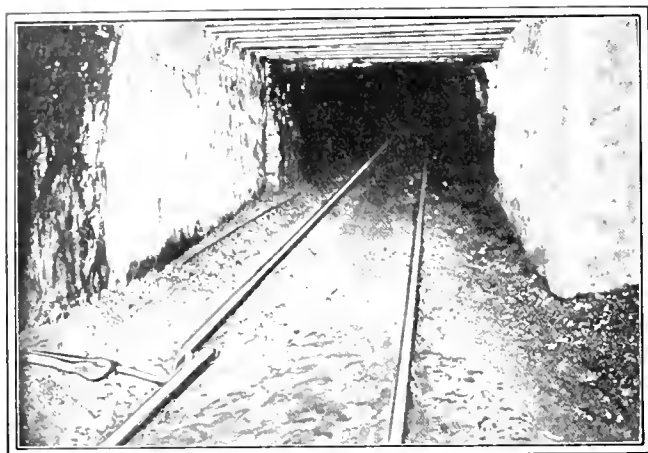

FIG. 9. SHOWING CONSTRUCTION OF OVERCAST, ALSO DERAILING SWITCH

shown in Fig. 9. The problems peculiar to hoisting and safety about the shaft have been handled on the principle—as indeed have all the safety appliances—that it is necessary to make the mines not only so safe that men will not be hurt, but so that they positively cannot be hurt.

來 來

Plan to Get More Large Coal

Payment for coal upon a run-of-mine basis is unsatisfactory to the operator and should be to the miner as well. Coal is almost invariably sold upon a sliding scale of prices determined by the size the consumer demands; the larger the size, the higher the price. Of all the sizes, that bringing the lowest price is slack, which varies in size in different districts between that passing through a $\frac{3}{4}$ -inch to that passing through an $1\frac{1}{4}$ -inch screen. The selling price of slack coal also varies widely at certain seasons of the year, whereas that for lump remains fairly constant within narrow limits, and again the price at which slack is sold is more below the price paid for digging mine-run coal than the price of lump coal is above it. As an illustration, when the price of pick mining in the Pittsburgh district is, say, 85 cents a ton, the selling price of lump coal during the Lake season will be \$1.10 to \$1.20, while the price of slack will vary about 75 cents as a maximum to as low as 35 cents. Adding a labor cost of 15 cents to each ton, the nominal profit on lump coal is from 10 to 20 cents and the loss on slack coal from 25 cents to 65 cents. Any method of mining or any system of payment that will reduce the proportion of slack in run-of-mine is, therefore, welcome to the operator.

If coal is paid for upon delivery to the tippie regardless of its condition, the miner naturally "gets it out" with the least possible labor. This means shallow mining, misplaced holes, excessive charges of powder and, consequently, an increased number of accidents. In order to save his muscles the miner usually risks both life and limb.

In order to overcome the disadvantage of paying upon a mine-run basis, that is for all the coal mined regardless of its condition, and at the same time to offer an incentive to the miner to produce a greater percentage of lump, one of the larger companies is trying out a plan which, after three months trial

under rather adverse and irregular commercial conditions, promises very satisfactory results. The mine-run coal is weighed in the car as it comes from the mine. After screening, the lump coal is weighed separately. The difference in these weights gives that of the fine coal which comprises the nut, pea, and slack.

In order to arrive at a just price for these two grades the proportion of each in the mine run was determined from the weights of coal sold for a period of three years. Knowing the proportions of lump and fine coal and having the mine-run price, it was easy to deduce a price for each grade separately. Any increase in the proportion of lump coal means an increased income for the miner and vice versa.

With an irregular run, as stated, the plan is giving good results, indicating a decrease in the proportion of fine coal of about 9 per cent. (about 7 per cent. in the pea and nut combined and 2 per cent. in the slack) and a corresponding increase in the amount of lump.

The reduction in the amount and cost of the powder used by reason of proper mining combined with the higher price received for the larger proportion of lump has more than offset the slightly increased labor necessary to make the mining in the soft underclay instead of in the coal itself as heretofore.

來 來 Rock Dump

The already high and rapidly increasing cost of lumber, particularly of the larger sizes needed for the posts and caps of rock dumps, renders advisable the adoption of devices which will increase the width of the dump per unit of length. As ordinarily arranged, unless excessive shoveling be done, rock dumps of the end-discharge type rarely give a top width of more than the length of the tie, say, about 5 feet.

In the August issue of MINES AND MINERALS was described the machine in use at Cokedale which gives a top width of rather more than 54 feet, and here is noted one used at the Cameron mine, Walsenburg, Colo., which, while the top width resulting from its use does not approximate to that obtained at Cokedale, is much simpler in construction.

The dump consists essentially of three plates of $\frac{1}{8}$ -inch iron 3 ft. \times 4 ft. in size. To the top plate are bolted a pair of mine rails with the ends bent up into horns. This upper plate revolves on the mine car axle, *e*, the bearings for which are supported upon a mine rail and bolted to the middle plate. A piece of channel iron, *d*, is bolted to the middle plate and upon it the dump falls back after a load of rock has been discharged. The upper plates as a unit revolve upon the two annular pieces of iron, *b*, 22 inches in diameter. The kingpin, *c*, is 1 inch in diameter and the plates, where it passes through them, are reinforced by a piece of $\frac{1}{2}$ " \times 3" bar iron. The lower plate is supported by four short lengths of 12-pound mine rail.

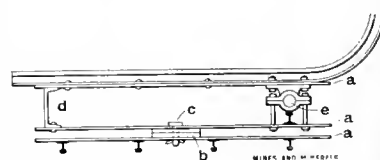

ROCK DUMP AT CAMERON MINE

This dump, handled by 2 men, gives a top width of from 10 to 12 feet or rather more than double what it would if of the end-discharge type. The trestle has therefore to be advanced only one-half as fast as usual and the saving in materials and labor is obvious.

As this dump was made from materials on hand at the mine, certain changes might be advisable if specially constructed. The dump might be mounted on a truck for ease in moving forward, bars or channels might be substituted for the plates, and, in order to reduce friction, the upper portion may be made to revolve upon small wheels or rollers instead of flat rings.

However, it admirably fulfils the idea of adding to the available top width of the dump and is to be commended therefor.

✻

Correspondence

✻

Oscillating Screens and Concrete Construction

Editor Mines and Minerals:

SIR:—Will some reader of MINES AND MINERALS advise the writer if there are any concrete tipples in this country using shaking screens. Is it advisable to use a concrete structure with oscillating screens imparting constant vibration to the structure?

J. E. B.

Stearns, Ky.

Early Watering of Mines and Employment of Shot Firers

Editor Mines and Minerals:

SIR:—On page 66 of the September number of your magazine you request your readers to advise you if they know of an earlier date than May, 1895, on which watering of dust was practiced, or shot firers were employed in American mines. If you will turn to the proceedings of the Mine Inspectors' Institute that was held in your city, or to my second annual report as Chief Mine Inspector of this state, on page 11 you will find a complete history of when shot firers were first employed in what was then the Indian Territory. You will find that shot firers were employed in 1885 in the mines of Krebs and Savanna, Indian Territory. I was one of the first men employed to fire shots. Up until that time I did not think that anything but firedamp could cause an explosion in a coal mine, but I was soon convinced that firedamp was not a necessary factor in producing explosions, and that coal dust and cold air when mixed formed an extremely explosive mixture, and a shot overcharged with powder that will create an intense heat and flame will cause it to explode. I insisted that the company sprinkle the dust, which was done, although it did not stop explosions. The same year I used the exhaust of the pump, and the more I studied and experimented the more convinced I became that steam was a solution of the problem. We laid pipes and allowed steam to escape into the intake airway; the steam as it escaped warmed the air, making the mine's condition practically the same in winter as in summer, and we had no windy shots or explosions while we used the steam. These experiments were all made in 1885. I am sending you under separate cover a copy of my second and third annual reports in which you will find all the information you desire.

PETE HANRATY

McAlester, Okla.

Early Shot Firers

Editor Mines and Minerals:

SIR:—Regarding Mr. Watson's article on shot firers and road sprinkling. He may have originated the latter in sprinkling with hose and nozzle, but watering roads in coal mines was established in Indian Territory, now Oklahoma, long before the time Mr. Watson speaks of. I was then a driver and watered the entry roads many times. We used a common water car with a 3-inch crescent-shaped pipe attached to one end of the car. On April 1, 1885, an explosion occurred in Savanna mine No. 2, 20 miles south of McAlester, Okla., on the M., K. & T. Railroad. The mines were very gaseous and also dusty. No. 1 and 2 mines employed shot firers a year previous to this explosion, which took place April 12, 1885. The shot firers who were killed in this explosion were Hugh Dooley, Davey Jones, and Charles Parsons. Also one driver and one rope rider, Bert French. There was one more shot firer whose name I cannot recall and 12 rescuers lost their lives in this accident, making a total of 18 men. This was practically a new mine, the slope was down 18 levels, or about 1,500 feet. It was a double slope with two tracks and entries turned 300 feet apart on both sides. All stoppings were put in with rock, lime, and sand. This slope was so badly wrecked by the explosion it never was reopened.

The readers of MINES AND MINERALS will find that shot firers were employed long before Mr. Watson speaks of, as this was nearly 27 years ago.

WM. CLARKE

Bowen, Colo.

Coal-Dust Explosions

Editor Mines and Minerals:

SIR:—I notice in your issue for September an article by John Verner, State Mine Inspector of Iowa, in which a quotation from Professor Payne's evidence at the Monongah inquiry is made as follows: "Had there been sufficient air to support combustion, the almost incredible pressure of 21,600 pounds per square foot would have been reached with a temperature of 4,683° F."

Mr. Verner does not say that he considers it "incredible," but the experiments made at Altofts in England and Lievin in France show that it is not nearly so high as is actually developed in experimental galleries.

Assuming that the experiences of the men referred to by Mr. Verner were actually as related by them, then it follows that there is no "pioneering cloud of dust" traveling in front of an explosion of coal dust, and the explosion must therefore be due to the dust normally in the mine ventilation, and not to that deposited on the perimeter of the roadways.

Personally I am pleased to see on page 81 another of Mr. Verner's communications, viz.: "Lessons to Be Learned From Recent Disasters," in which he says that a mine cannot be rendered immune from explosions under any conditions by the application of moisture; and this emphatically supports my long time opinion on this subject. (See my article on the subject of watering in MINES AND MINERALS in 1903.)

JAMES ASHWORTH

Watering Dust in Utah

Editor Mines and Minerals:

SIR:—In the September number of MINES AND MINERALS there is an editorial entitled "An Historic Mine," in which the statement is made that the first watering of dust in mines of this country was done in the Como mine No. 5 of Park County, Colo., in 1895.

I desire to correct this statement, as it can be proven that sprinkling by hose and also spraying the intake air by means of steam and water was employed in the Castle Gate mine of the Utah Fuel Co. as early as 1892.

For proof of this I beg to refer you to the report of the United States Inspector of Coal Mines for the Territory of Utah for the year 1892. Mr. Robert Forrester, deceased, then United States Inspector and later geologist for the Utah Fuel Co., reported as follows:

"The dust of the mine is very inflammable, and extra precautions have to be taken for the safety of the workmen employed therein.

"The dust is kept in a very wet condition by means of water pipes laid throughout the entire mine, and water is taken to the working faces by a hose. Two men are employed at this work regularly.

"On the intake airways there are vertical water pipes at regular distances, with a $\frac{1}{2}$ -inch pet cock at the top. The water emerging from these pet cocks is struck in a horizontal direction by steam under a pressure of 30 pounds per square inch (escaping from a pet cock of the same size), the water being blown into a fine spray and the most of it being taken up by the air passing along the gallery.

"On the outside the hygrometer frequently registers a difference of from 20 degrees to 35 degrees between the wet and dry bulb thermometers, and at a point 1,500 feet from the mouth of the mine the difference registered seldom exceeds 1 degree, while at the far end of the mine, 4,000 feet from the mouth of the mine, the air has been fully saturated for over a year past."

This report is dated March 4, 1893, for the year 1892. Farther on in the report is given a table showing relative humidity, dew point, and grains of water per cubic foot of air for each month of the year 1892, which proves conclusively that sprinkling was in full practice in this mine in January, 1892, and was probably installed previous to that.

Owing to the fact that most of the writers on this subject have been eastern men unfamiliar with coal-mining operations in Utah, the gentlemen in charge of the mines at that time have been given little credit for the work they did. The facts are that methods were employed in Utah years before they were in other parts of the country and the operators of that time were really pioneers in the use of electricity, sprinkling, and electrical firing of shots from the outside after all the men were outside the mine.

A. C. WATTS,

Chief Engineer Utah Fuel Co.

來 來

Books Received

UNITED STATES GEOLOGICAL SURVEY PUBLICATIONS, Washington, D. C. Bulletin No. 448, Geology and Mineral Resources of the Nizina District, Alaska, by Fred H. Moffit and Stephen R. Capps; Bulletin No. 449, A Geological Reconnaissance in Southeastern Seward Peninsula and the Norton Bay-Nulato Region, Alaska, by Philip S. Smith and H. M. Eakin; Bulletin No. 450, Mineral Resources of the Llano-Burnet Region, Texas, with an account of the Pre-Cambrian Geology, by Sidney Paige; Bulletin No. 451, Reconnaissance of the Ore Deposits in Northern Yuma County, Ariz., by Howland Bancroft; Bulletin No. 454, Coal, Oil, and Gas of the Foxburg Quadrangle, Pennsylvania, by Eugene Wesley Shaw and Malcolm J. Munn; Bulletin No. 455, Copper Deposits of the Appalachian States, by Walter Harvey Weed; Bulletin No. 457, Results of Spirit Leveling in the State of Washington, 1896 to 1910, Inclusive, by R. B. Marshall, Chief Geographer; Bulletin No. 462, Results of Spirit Leveling in Oregon, 1896 to 1910, Inclusive, by R. B. Marshall, Chief Geographer; Bulletin No. 468, Results of Spirit Leveling in Texas, 1896 to 1910, Inclusive, by R. B. Marshall, Chief Geographer; Bulletin No. 470-B, Advance Chapter From Contributions to Economic Geology for 1910, Gold and Silver, by J. S. Diller, E. S. Larsen, J. T. Pardee, F. C. Schrader, R. W. Stone, J. M. Hill, and Sidney Paige; Bulletin No. 470-D, Advance Chapter From Contributions to Economic Geology, 1910, Lead and Zinc, by R. W. Richards and Howland Bancroft; Bulletin No. 470-G, Advance Chapter From Contributions to Economic Geology for 1910, Structural Materials, by Charles Butts, T. N. Dale, G. B. Richardson, E. W. Shaw, Alexander Deussen, and E. F. Burchard; Bulletin No. 472, Results of Spirit Leveling in South Dakota, 1896 to 1910, Inclusive, by R. B. Marshall, Chief Geographer; Bulletin No. 476, Results of Spirit Leveling in Ohio, 1909 and 1910, by R. B. Marshall, Chief Geographer; Bulletin No. 477, Results of Spirit Leveling in West Virginia, 1909 and 1910, by R. B. Marshall, Chief Geographer; The Production of Graphite in 1910, by Edson S. Bastin; Silver, Copper, Lead, and Zinc in the Central States in 1909, by B. S. Butler and C. E. Siebenthal; The Production of Talc and Soapstone in 1910, by J. S. Diller; The Production of Peat in 1910, by Charles A. Davis; The Production of Manganese Ore in 1910, by Ernest F. Burchard; The Production of Mineral Paints in 1910, by Ernest F. Burchard; The Production of Bauxite and Aluminum in 1910, by W. C. Phalen; The Production of Sand-Lime Brick in 1910, by Jefferson Middleton; The Production of Anthracite Coal in 1910, by Edward W. Parker; Water-Supply Paper, No. 256, Geology and Underground Waters of Southern Minnesota, by C. W. Hall, O. E. Meinzer, and M. L. Fuller; Water Supply Paper No. 265, Surface Water Supply of the United States for 1909, by Robert Follansbee, A. H. Horton, and R. H. Bolster; Water-Supply Paper No. 267, Surface Water Supply of the United States for

1909, Part VII, Lower Mississippi Basin, by W. B. Freeman and R. H. Bolster; Water-Supply Paper No. 268, Surface Water Supply of the United States for 1909, Part VIII, Western Gulf of Mexico, by W. B. Freeman and R. H. Bolster; Water-Supply Paper No. 273, Quality of the Water Supplies of Kansas, by Horatio Newton Parker. Professional Paper No. 70, The Mount McKinley Region, Alaska, by Alfred H. Brooks, with descriptions of the igneous rocks and of the Bonfield and Kantishna Districts, by L. M. Prindle.

UNITED STATES DEPARTMENT OF AGRICULTURE, Washington, D. C., Bulletin No. 38, Methods for the Examination of Bituminous Road Materials, by Prevost Hubbard and Charles S. Reeve; Bulletin No. 88, Properties and Uses of Douglas Fir, by McGarvey Cline and J. B. Knapp; Bulletin No. 89, The Olympic National Forest, Its Resources and Their Management, by Findley Burns; Bulletin No. 90, Relation of Light Chipping to the Commercial Yield of Naval Stores, by Charles H. Herty, Ph.D.; Bulletin No. 95, Uses of Commercial Woods of the United States, by William L. Hall, Assistant Forester, and Hugh Maxwell, expert.

DEPARTMENT OF COMMERCE AND LABOR, Washington, D. C., Bulletins No. 93 and 94 of the Bureau of Labor.

BUREAU OF MINES, Washington, D. C., Schedule 1, Fees for Testing Explosives, and Conditions and Requirements Under Which Explosives Are Tested; Technical Paper No. 4, The Electrical Section of the Bureau of Mines, Its Purpose and Equipment, by H. H. Clark; Bulletin No. 12, Apparatus and Methods for the Sampling and Analysis of Furnace Gases, by J. C. W. Frazer and E. J. Hoffman; Bulletin No. 14, Briquetting Tests of Lignite With a Chapter on Sulphite-Pitch Binder, by Charles L. Wright.

WASHINGTON GEOLOGICAL SURVEY, Henry Landes, State Geologist, Seattle, Wash., Bulletin No. 2, The Road Materials of Washington; Bulletin No. 6, Geology and Ore Deposits of the Blewett Mining District, by Charles E. Weaver.

CANADA DEPARTMENT OF MINES, Mines Branch, Eugene Haanel, Director, Ottawa, Canada, Bulletin No. 5, Magnetic Concentration Experiments With Iron Ores of the Bristol Mines, Quebec, Iron Ores of the Bathurst Mines, New Brunswick, a Copper Nickel Ore From Nairn, Ontario, by George C. Mackenzie, B. Sc. Twentieth Annual Report of the Bureau of Mines, Toronto, Ontario, Canada, for 1911, Vol. XX, Part II, The Porcupine Gold Area, by A. G. Burrows.

GEOLOGICAL SURVEY OF GEORGIA, S. W. McCallie, State Geologist, Atlanta, Ga., Bulletin No. 25, A Preliminary Report on Drainage Reclamation in Georgia.

BUREAU OF SCIENCE, Manila, P. I., Vol. VI, No. 2, The Philippine Journal of Science, by Paul C. Freer, M. D., Ph. D.

WISCONSIN GEOLOGICAL AND NATURAL HISTORY SURVEY, Madison, Wis., Bulletin No. 21, The Fossils and Stratigraphy of the Middle Devonian of Wisconsin, by Herdman F. Cleland, Ph. D.; Bulletin No. 22, The Inland Lakes of Wisconsin, The Dissolved Gases of the Water and Their Biological Significance, by Edward A. Birge and Chauncey Juday.

GEOLOGICAL SURVEY OF OHIO, J. A. Bownocker, State Geologist, Columbus, Ohio, Fourth Series, Bulletin No. 13, The Maxville Limestone, by William Clifford Morse.

COAL REPORT, ILLINOIS BUREAU OF LABOR STATISTICS, 1910, David Ross, secretary, Springfield, Ill.

REPORT OF DEPARTMENT OF GEOLOGY AND NATURAL RESOURCES OF INDIANA, 1910, W. S. Blatchley, State Geologist, Indianapolis, Ind.

GEOLOGICAL SURVEY OF NEW JERSEY, Henry B. Kummel, State Geologist, Trenton, N. J., Iron Mines and Mining in New Jersey, by William S. Bayley.

CALIFORNIA STATE MINING BUREAU, Lewis E. Aubury, State Mineralogist, San Francisco, Cal., Bulletin No. 60, Mineral Productions, County Maps and Mining Laws of California.

REPORT OF DEPARTMENT OF MINES OF PENNSYLVANIA, Part II, Bituminous, 1910, James E. Roderick, Harrisburg, Pa.

Answers to Examination Questions

Utah Mine Foremen's, February, 1911, and Selected Questions from Illinois Examinations, 1910

(Continued from September)

QUES. 23.—What are the general requirements in regard to the construction of doors, overcasts, and stoppings? State their several uses.

ANS.—The general requirement is that all doors, overcasts, and stoppings in mines shall be substantially built of incombustible material and made air-tight. Doors should be hung so as to close with a slight fall with the air-current. As far as practicable, doors should be located where they will not endanger the lives of drivers or runners. Doors are used in mines to deflect air-currents and permit the passage of men and coal. Overcasts are used to conduct one air-current over another that crosses its path; an overcast is often used to obviate the use of a door and supply a separate air-current to a certain district or pair of entries. Stoppings are employed to close the openings of abandoned places and cross-cuts no longer needed.

QUES. 24.—A rectangular airway 8 ft. \times 10 ft. is 5,000 feet long; what must be the length of an airway 6 ft. \times 6 ft. that will have the same amount of rubbing surface?

$$\text{ANS.—} \frac{8+10}{6+6} \times 5,000 = 7,500 \text{ ft.}$$

QUES. 25.—Explain the principle of the safety lamp.

ANS.—The flame of the lamp is surrounded by a chimney of wire gauze, or glass and wire gauze, by which it is completely isolated from the atmosphere outside the lamp. The mixed air and gases enter the lamp through the meshes of the gauze, the gas often burning inside of the lamp chimney, which may at times become filled with flame. The metal wire absorbs the heat of the flame in proximity to the gauze, and thereby reduces the temperature of the burning gas below what is required to maintain the combustion, and the flame is therefore extinguished and prevented from passing through the gauze as long as the gauze keeps sufficiently cool.

QUES. 26.—Describe in detail the Davy and Wolf safety lamps, or other makes of lamps with which you are familiar.

ANS.—The Davy lamp is an oil vessel surmounted by a gauze chimney, the top of which is protected by a gauze cap that fits over that portion of the chimney. The Wolf lamp is a special lamp designed to burn naphtha. The chimney is of glass surmounted by gauze which is protected by a steel bonnet. The lamp requires an igniter being placed in the lamp owing to its being readily extinguished. The volatile nature of the oil causes the lamp to heat quickly in gas, which renders the lamp unreliable for testing purposes. The American Beard-Deputy lamp is a Marsaut type, admitting its air below the flame and having a double-gauze chimney with or without bonnet. The glass is 3½ inches in height. The lamp burns ordinary sperm or cottonseed oil, gives a good light, and with an indicator shows as low as ½ of 1 per cent. of gas by the plain incandescence of the platinum wires of the indicator.

QUES. 27.—Explain fully what regulations you would adopt for the use of safety lamps in mines.

ANS.—There should be an adequate number of safety lamps of an approved pattern kept on hand at every mine, ready for use in time of need. Safety lamps should not be introduced in a mine as long as it is possible to maintain a safe condition of the mine atmosphere by means of an ample ventilating current properly distributed. In districts of a mine where safeties are required at the working face the use of open lights should be strictly forbidden. The use of mixed lights in any district of a mine should never be allowed. All safety lamps used in a mine, except the lamps of the fire bosses, should be the property of the company and in charge of a duly authorized person who shall direct the entire care of the lamps and their delivery to

workmen. All fire bosses should own and care for their own lamps. None but fire bosses should be allowed to carry lamp keys or have the same in their possession in the mine.

QUES. 28.—Which are the most dangerous gases met with in coal mines?

ANS.—All mine gases are or may be dangerous.

QUES. 29.—Name the gases met with in coal mines, giving their symbols, and their effect on the human system. State which are explosive and which non-explosive.

ANS.—Marsh gas or methane (CH_4); if breathed, pure methane would suffocate, but mixed with sufficient air it produces only a slight dizziness. Carbon monoxide (CO); extremely poisonous causing death. Carbon dioxide (CO_2); causes headache, nausea, pain in back and limbs, and death by suffocation. Hydrogen sulphide (H_2S); poisonous, deranges the system and causes death. Olefiant gas (C_2H_4); its effect on the system is similar to that of marsh gas. With the exception of carbon dioxide, all these gases form explosive mixtures with air.

QUES. 30.—What is afterdamp, and why is it, at times, so much more fatal and dangerous than at other times?

ANS.—Afterdamp is the variable mixture of gases that remains in the mine workings as the result of an explosion of gas or dust, or both combined. The deadly nature of the afterdamp is determined chiefly by the percentage of carbon monoxide it contains. When the supply of air, at the moment of explosion, is limited, the combustion is incomplete and carbon monoxide is formed, which is extremely poisonous and renders the afterdamp more quickly fatal than when the explosion takes place in a plentiful supply of air, and carbon dioxide results.

QUES. 31.—(a) Could you depend absolutely on a safety lamp for the detection of all gases produced in a coal mine? (b) What other methods would you adopt for the detection of gases?

ANS.—(a) No; neither carbon monoxide nor hydrogen sulphide should be sought with the lamp. (b) The former should be sought by observing the behavior of a small caged mouse, which is prostrated and rendered helpless by this gas in about one-twentieth of the time required to produce the same effect on a man. The latter gas is best detected by its peculiar odor.

QUES. 32.—Describe the action of the flame of a safety lamp when exposed to the different gases found in coal mines.

ANS.—Marsh gas elongates and increases the size of the flame, producing also a pale-blue flame cap, only visible when the gas approaches 3 per cent. Olefiant gas associated with marsh gas renders the flame more violent and disturbed, and the cap is not as plainly seen. Carbon monoxide lengthens the flame and increases its brightness somewhat. Carbon dioxide dims and reduces the size of the flame till it is finally extinguished if sufficient gas be present. Hydrogen sulphide is never present in sufficient quantity in mines to produce any effect on the flame of a safety lamp.

QUES. 34.—In mines where fires due to spontaneous combustion are common, what is the first evidence that such a fire is in progress, and what means should be taken to extinguish the same?

ANS.—The experienced miner easily detects the existence of such fire by the peculiar odor or taint given to the air in the vicinity. Later the presence of the fire is revealed by the increased temperature of the adjoining workings.

QUES. 36.—State in detail what should be done to reduce the number of accidents due to falls of rock and coal, and movement of mine cars.

ANS.—Increase if possible the efficiency of the inspection of all working places. See that the required supplies of timber and caps are delivered promptly to the men; and insist that the work of securing the roof in all working places shall receive attention before the work of loading coal is begun. Instruct miners how to timber their places properly. Make it the first duty of all miners to sound the roof in their several working places upon first entering the same in the morning and after

ring a shot. Provide good haulage roads of sufficient width to allow persons to pass cars on one side of the track at least. Keep tracks in good order, well cleaned and timbered. Arrange suitable turnouts with automatic switches, making the straight track the loaded track. Have inside drivers observe strict rules in regard to passing point. Avoid placing doors at the bottom of grades where cars may not be fully under control. Provide refuge holes for door boys. Provide suitable traveling-ways and allow no traveling on rope- or motor-haulage roads.

QUES. 37.—Where does the most dangerous dust lie, on the floor, walls, gob, or timbers?

ANS.—The dust that accumulates on the walls and timbers is not only on the whole finer and more easily thrown into suspension in the air by any disturbance, but it has generally absorbed more oxygen and is more inflammable and dangerous than the dust that lies on the floor.

QUES. 38.—How tight should props be set or wedged in rooms and entries?

ANS.—Room timbers, in particular, should only be wedged tight enough to insure that the post will not fall out, or cannot be knocked out easily. The settlement of the roof will always tighten the post, and all post timbers should be closely watched to determine the action of the roof and its progress.

SELECTED QUESTIONS OF THE ILLINOIS (1910) EXAMINATIONS HELD AT SPRINGFIELD, ILLINOIS

NOTE.—The following questions, selected from different examinations, are here numbered consecutively. The date and kind of examination and number of the question follow each question; indicated as follows: (M) mine managers'; (E) mine examiners'; (H) hoisting engineers' examination.

QUES. 1.—If a 42-horsepower fan is producing 113,224 cubic feet of air per minute in a certain mine, what volume of air will a 50-horsepower fan produce at the same mine, under the same conditions? M., Q. 3, 1-17-10

ANS.—Assuming equal efficiencies, the air volume will be proportional to the cube root of the power; or the volume ratio will equal the cube root of the power ratio; thus, calling the required volume x ,

$$\frac{x}{113,224} = \sqrt[3]{\frac{50}{42}} = \sqrt[3]{1.190476} = 1.06, \text{ nearly}$$

$$x = 113,224 \times 1.06 = \text{say, } 120,000 \text{ cu. ft. per min.}$$

QUES. 2.—What thickness of pillars should be left around the shaft bottom, in the Illinois, No. 5 seam, the coal being 4 feet 10 inches high and the shaft 450 feet deep; while the average cover is 475 feet? Underlying the coal is 2 feet of fireclay and under that 3 feet of lime rock. Overlying the coal is 2 feet of slate and above that 8 inches of cap rock; above that again 12 feet of sandstone overlaid with shale, clay, and soil. What should be the thickness of pillar between the main entry and return airway? What thickness of pillars should flank the main entry and airway, dividing them from the rooms? What should be the thickness of the cross-entry pillars in this mine? The shaft is in the center of a coal field of 640 acres.

M., Q. 4, 1-17-10

ANS.—The diameter of a circular, or the length of side of a square, shaft pillar should be, in this case, $6\sqrt{D} \times t = 6\sqrt{450} \times 4.83 = \text{say, } 280 \text{ feet}$. To determine proper width of entry pillars it is important to first ascertain as nearly as possible the safe width of opening (w) under the given conditions. This will depend chiefly on two factors, the strength of the roof rock and the depth of cover. In the absence of practical data, divide the strength of the rock (say, 1,500 pounds per square inch) by the depth of cover in feet, extract the square root of the quotient and multiply by the thickness of the rock in feet; thus, $w = 12\sqrt{\frac{1,500}{475}} = 21 + \text{feet}$. If the overlying material is firm hard strata this width of opening may be increased 25 per cent., giving in this case, say 26 feet. In the present case,

the main entry pillars should be 25 feet wide; the pillars flanking the main entry and air-course 30 feet, and the cross-entry pillars 20 feet wide.

QUES. 3.—If 3.5 horsepower is required to circulate 10,000 cubic feet of air in three airways, each 6 feet \times 5.5 feet in section, what horsepower will be required to produce the same circulation in a single 10' \times 10' airway; all the airways being of the same length? M., Q. 5, 1-17-10

ANS.—The combined perimeters and the total area of cross-section for the three airways are $o = 3 \times 2(6 + 5.5) = 69 \text{ feet}$; $a = 3(6 \times 5.5) = 99 \text{ square feet}$; for the single airway, $o = 4 \times 10 = 40 \text{ feet}$, $a = 10 \times 10 = 100 \text{ square feet}$. The power producing circulation is proportional to the perimeter and inversely proportional to the cube of the area; or the power ratio, in this case, is equal to the product of the perimeter ratio and the cube of the inverse area ratio; thus, calling the required horsepower x ,

$$\frac{x}{3.5} = \frac{69}{40} \left(\frac{100}{99} \right)^3 = 1.778, \text{ nearly;}$$

$$x = 3.5 \times 1.778 = 6.222 \text{ H. P.}$$

QUES. 4.—How many acres and tons of lump coal can be mined from the following described piece of land: Commencing at the southwest corner of the northwest quarter of Section 25, thence running due north 500 feet; thence, N 85½° E, 532 feet; thence, N 81¼° E, 733 feet; thence, N 76½° E, 521 feet; thence, N 79½° E, 665 feet; thence, S 75¼° E, 336 feet; thence, due south S16 feet; thence, westerly to place of beginning? The average

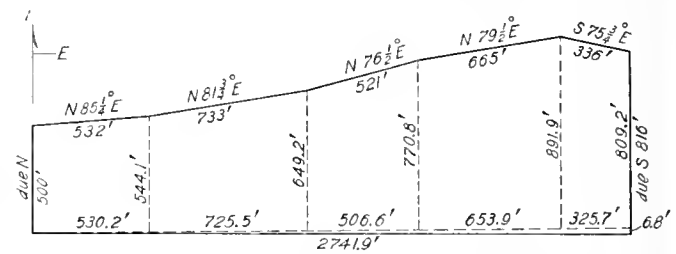

FIG. 1

thickness of the coal in the seam is 4 feet 6 inches; allow 27 cubic feet of coal in place per ton, 20 per cent. for waste, and 30 per cent. fine coal? M., Q. 6, 1-17-10

ANS.—Following is the traverse and Fig. 1 is the diagram of the survey:

Course	Distance	N	S	E	W
Due N	500	500.0			
N 85½ E	532	44.1		530.2	
N 81¼ E	733	105.1		725.5	
N 76½ E	521	121.6		506.6	
N 79½ E	665	121.1		653.9	
S 75¼ E	336		82.7	325.7	
Due S	16		16.0		
		891.9	898.7	2,741.9	
			891.9		
			6.8		

The area of the survey is calculated as follows:

	Square Feet
$530.2 \times \frac{1}{2} (500 + 544.1)$	276,791
$725.5 \times \frac{1}{2} (544.1 + 649.2)$	432,869
$506.6 \times \frac{1}{2} (649.2 + 770.8)$	359,686
$653.9 \times \frac{1}{2} (770.8 + 891.9)$	543,620
$325.7 \times \frac{1}{2} (891.9 + 809.2)$	277,024
$\frac{1}{2} (6.8 \times 2,741.9)$	9,322
Total	1,899,312

Area of survey 1,899,312 \div 43,560 = 43.60 + acres.
 Mineable lump coal, estimated, .50 (1,899,312 \times 4.5) + 27 = 158,276 tons.

(Continued in November issue)



Scientific coal mining requires that the plan of mine be so arranged that main entries be driven to the boundary lines of the property. From this point rooms should be driven in panels so that all coal may be speedily removed. In the end this system pays the operator.

ORE MINING AND METALLURGY

The Pioche, Nevada, District

Interesting Geological Conditions. Mines Made of Value by Improved Transportation Facilities.

By R. M. Bell*

The famous old camp of Pioche is the county seat of Lincoln County, Nev. It is reached by way of the main line of the San Pedro Railroad to Caliente, thence by a branch line 32 miles in length running north to Pioche.

The name would imply that a Frenchman was one of its first citizens, and the fact that a double row of old locust trees borders its main street, which add a homelike touch to a general desert aspect, would also indicate that the advance agents of the Mormon church were in at the making of the new camp.

The general topography of the surrounding country is typical of Nevada. A broad desert valley 10 to 15 miles wide extends north for 75 miles above Caliente, with an elevation varying from 4,000 to 6,000 feet above sea level, and is bordered on either hand by prominent north and south mountain ranges composed of a vast accumulation of ancient sedimentary formations and igneous rocks that reach a maximum elevation of 9,500 feet above the sea level.

The Ely mining district is the legal name of the recorded district immediately surrounding Pioche. This name should be changed by petition to avoid confusion with the Ely copper district further north. The recorded mining district covers a low mountain ridge that strikes obliquely across the main valley with a general trend a little north of west and south of east. This uplift presents a topographic freak, and is probably due to a buried laccolite of igneous matter relatively rich in metals, and the source of the district's rich mineralization.

The Pioche ridge, shown in Fig. 1, is separated from the main west range by a valley of erosion a mile wide and dying out to the east before it reaches the opposite range. It is 15 miles long by about 3 miles broad.

The Pioche mines were discovered in 1869. The nearest railway point at that time was on the Central Pacific, at Winne-

muca, Nev., 300 miles to the north. The principal mines were rapidly located, as their rich ores outcropped to the surface in many instances, and a wild stampede from the north soon followed. In 1872 the camp had a population of 10,000 people, and tradition says it was about the wildest proposition in western mining life ever recorded, since its daily paper had from one to half a dozen men for breakfast as common news items. The original claims were located only 200 feet wide under the old law and owing to the complex system of parallel and intersecting fissures, conflicting claim lines, and confused apex rights to the rich ore bodies, the costs of fighting men to protect their rights soon constituted a big item in the running expenses of the principal companies.

In 10 years subsequent to their discovery the main quartzite fissures of the Raymond-Ely and Meadow mines had been stoped in a close succession of rich ore shoots 2 to 6 feet thick for a continuous stretch

of 2,000 feet and to a depth of 1,200 feet, and had yielded a gross output of \$20,000,000 at a net profit of \$5,000,000. The ore was a friable quartz gangue, containing lead carbonates associated with silver chloride and native gold, and is said to have averaged over \$200 per ton, of which 20 per cent. was gold and the balance silver. The ore was treated by the pan grinding and amalgamation process. Dry Valley and Bullionville being the

principal milling points, 6 and 12 miles distant, respectively.

The early cost of mining and milling, as given in the government reports, averaged \$75 per ton, and an accumulation of 150,000 tons of tailings at the milling points, containing an average value of 8 per cent. lead, will give an idea of the difficulties the pioneer mill men and metallurgists met and overcame.

The veins were dry down to a depth of 1,200 feet, where water and base ores were encountered. The latter were equally rich in gold and silver but contained too much lead and zinc to admit of a profitable extraction of the precious metals by milling, and so the industry rapidly waned.

In years subsequent to 1879 several attempts at smelting were made with an additional yield of something like \$10,000,000 from these and neighboring mines, but with coke as fuel for this purpose, hauled long distances by rail and overland by wagon freight from Modena, Utah, 140 miles distant, very little profit could have been made.

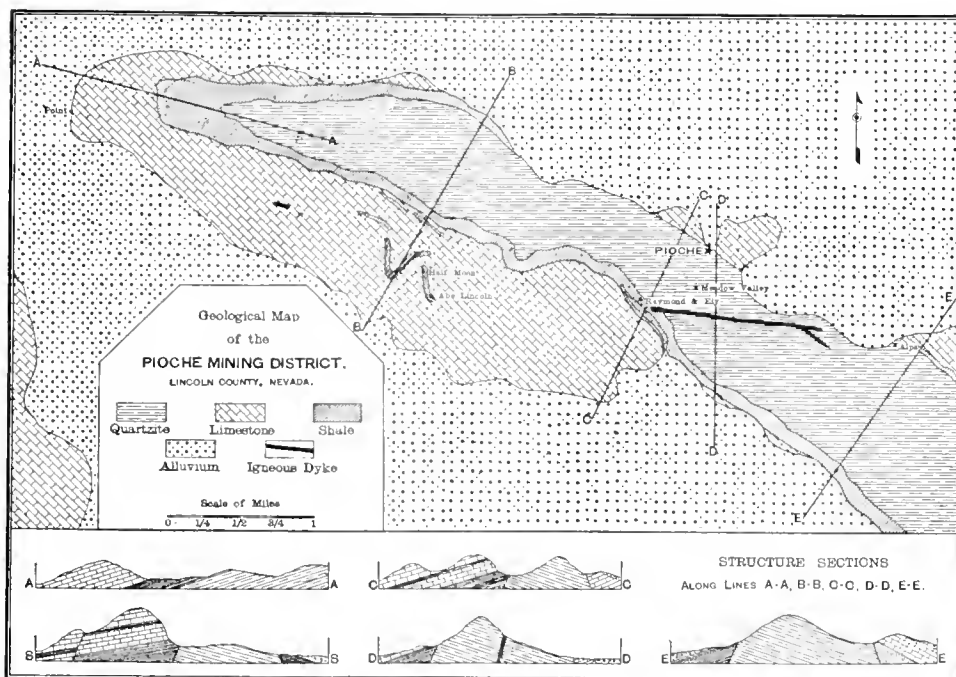

FIG. 1

* Formerly State Mine Inspector of Idaho.

With the recent advent of the San Pedro Railway into the camp, it has taken on a new lease of life, and activity has been stimulated all along the line. The camp has a present population of about 1,200 people. There are already a dozen gasoline mining plants in operation, ranging from 10 to 100 horsepower capacity, engaged in shaft sinking and mining development enterprises, and also a score or more of operations with temporary equipment of whip, whim, and windlass. Results in rich ore development are being obtained that give promise of rewarding the San Pedro for its advent with one of the most important sources of mineral traffic in the West. The richness and permanency of the ore deposits are established and their number and variety are remarkable.

Geological Conditions.—After arriving at Pioche, the writer ran across a technical review of the geology and ore deposits of the district, published in 1906 by Prof. F. J. Pack, Professor of Geology at the University of Utah.

The geology of Pioche is simple as to the variety of its formations, but has some rather complicated structural features due to faulting and erosion.

The main east-west uplift is a simple anticlinal fold rising at Mt. Ely to a maximum elevation of about 1,000 feet above the general level of the valley. The main axis of the ridge is heavy bedded, low dipping Cambrian quartzite of medium grain, stained reddish at the surface, but white and vitreous

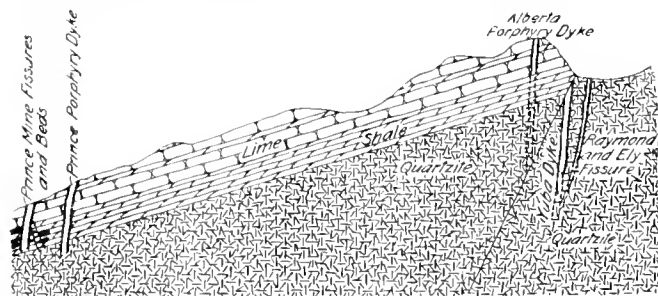

FIG 2

underground, without any secondary cleavage, but in places shattered.

The quartzite is flanked with conformable beds of clay shale, probably 500 feet thick, carrying a rich array of Cambrian fossils.

The main shale beds are succeeded by 400 or 500 feet of massive blue and gray limestone beds that have been greatly reduced by erosion, and disturbed by faulting, bed slipping, mineralization, and the intrusion of an important series of igneous dikes, as shown in Fig. 2.

The main west range is probably of similar origin to Pioche ridge, but on a broader scale. Its eastern base and for some distance up is composed of Cambrian limestones that are said to shade up into Silurian and higher horizons to the west and to represent a total connected series of ancient sediments fully 20,000 feet thick.

This west range is cut into segments by lines of northwest and southeast faulting and erosion. These features are locally called gaps and passes, of which Stampede Gap and Bristol Pass are examples.

Stampede Gap is 10 miles west of Pioche, and the mountain to the south of it for 15 miles in length, with its center 7 miles southwest of Pioche, is richly mineralized, and carries the Mendha and other properties that have made a bow to the mining world in the matter of rich ore production. This section is known as the Highland Mountains, and the Highland district.

North of Stampede Gap and extending to Bristol Pass, 15 miles farther north, is another mountain of heavy bedded blue and gray limestones, breccia conglomerates, and intrusive dikes, known as the Jack Rabbit Mountain, with the Bristol,

Day, Onondago, Hillside, Star, and other noted and promising ore deposits and producers near its northern end.

The west slope of this main range was not visited, but it is said that its altered sedimentary formations have been ruptured by a north and south outburst of gigantic monzonite, along the borders of which a rich array of contact metamorphic minerals occur, including large bodies of iron, garnet, and epidote, associated with rich silver, copper, gold and ore samples, and that some very interesting prospects are there in evidence.

The Pioche Record mining district above outlined, including Highland, Jack Rabbit, and Bristol, can practically duplicate in form and physical features all the more successful silver-lead and lead-silver ore deposits in the United States, and is sufficiently developed to identify the types. The flat bedded and contact deposits of Missouri and Leadville, associated with limestone, shale, and quartz porphyry are in a strong measure represented by the Mendha, Half Moon, Old Timer, Point, and Demijohn mines. The vertical fault fissures and ore-bearing shear zones of the Coeur d'Alenes are represented by the Raymond-Ely, Yuba Dike, Susan Duster, and Greenwood veins, while the great lens-shaped chamber deposits, and the bed-connected contraction and fault fissuring that have been such rich ore producers in Utah are represented by the Prince Consolidated, Day, Bristol, Star, Hillside, and others.

The ore deposits of Pioche are practically intact and uninjured by erosion, like those of the Coeur d'Alenes, and can be depended on to stand development and last in depth, except where locally displaced by faulting and leaching, to the point of original precipitation of the ascending mineral solutions that produced them.

This condition is demonstrated by the fact that the richest bonanza ore shoot of the Raymond-Ely mine was covered at its crest by 100 feet of shale in such a position on the quartzite axis of the uplift as to preclude the probability that it was ever connected through or exposed at the surface, except perhaps by a thin flat feeder in the shale bed.

The bonanza footwall fissures of the Prince Consolidated mine apex under 200 feet of limestone in the big gossan ore body, and the lower, flat-dipping, bedded deposits connect with those fissures at 300 and 400 feet deep.

The rich bedded ore body at the Mendha mine, carrying an average of an ounce in gold, 20 per cent. lead, and 20 ounces silver, was discovered at the bottom of an 800-foot incline shaft and vertically under 400 feet of limestone. It connects at this point with a vertical fissure that carries a different class of ore. This rich bedded deposit of silicious ore is probably rooted in a big vertical porphyry dike that traverses the limestones a few hundred feet to the south, which would form a good avenue of development and an easy formation in which to clip the ends of this and other associated ore-bearing beds of the Mendha group, and at the same time test out the ore-bearing possibilities of the dike itself. The famous Yuba dike ore shoots are all blind at the surface, and the big 30-foot ore body of sulphide mineral in the Susan Duster mine apexes as such at 10 feet under the surface.

The Raymond-Ely and Meadow Valley mines were operated entirely on a steep dipping fissure vein in the quartzite, that strikes nearly east and west and dips south at an angle of 60 degrees. From the 1,200-foot level of the Raymond-Ely shaft a cross-cut, driven south a few hundred feet, encountered a large porphyry dike striking due east and west, and also dipping south at an angle of 80 degrees. This dike is over 50 feet thick and consists of an extremely altered quartz porphyry. Within its structure, but lying next to its quartzite footwall, a body of massive black zinc-lead iron sulphide ore, several feet wide, was encountered, and a winze was sunk on it 300 feet below the 1,200-foot level, from which some drifting was done and ribs of clean galena ore encountered that were very rich in silver and gold. This is what was christened the Raymond-Ely

"Black Lead." Its discovery created quite a stock boom at the time, but the ore was too base to be of any value to the early-day operators.

The same dike was later found by a cross-cut at the 900-foot level of the Meadow Valley No. 5 shaft, 1,000 feet east of the first point, where a shoot of lead carbonate ore 200 to 300 feet long, rich in gold and silver, was worked nearly to the surface and produced over a million dollars worth of ore, on the Mazzeppa claim. A thousand feet further east, on the Yuba claim, another ore shoot was worked through an incline shaft 1,200 feet deep, and ore to the value of a million dollars extracted at this point.

This great stretch of rich ore-bearing porphyry fissures is owned jointly by the Nevada-Utah and Ohio-Kentucky companies. It is accessible at three points, varying from 300 to 1,200 feet deep, and could be rapidly put in shape for quite a heavy production of rich ore, which it must doubtless contain.

East of the Yuba claim the same dike is covered for a stretch of half a mile by the property of the Boston-Pioche Co., which is pushing down a 1,000-foot incline shaft on it that is already over 800 feet deep, and at the 300-foot level, where some little drifting was done, several carloads of the characteristic Yuba lead-silver ore were taken out and shipped last year; when drifting has been commenced at the deeper levels in this new shaft some very important strikes of rich ore can reasonably be anticipated.

This great ore-bearing porphyry dike is at present best exposed in the Pacific tunnel, where it has been cross-cut at a depth of 280 feet, drifted on and stoped for a length of 200 feet and a height of 50 feet.

To the writer this porphyry ore deposit presents the most attractive feature of the Pioche district, by reason of the striking structural similarity and probable origin, to some of the steady dividend-paying silver-lead ore deposits of north Idaho—namely the Standard, Mammoth, and the Hecla mines at Mace and Burke.

The Hecla mine is a nearly vertical zone of closely parallel shearing that followed an original dike-filled fissure of diabase porphyry in quartzite walls. This deposit was lean and carried very little commercial ore in the first 300 feet of depth below its apex. It gradually improved as development progressed, and at the 300-foot level it carries an ore shoot 1,000 feet long and up to 25 feet wide, consisting of two wide bands of galena ore, separated by extremely altered clayey diabase rock 5 feet thick and often showing a third central lensey streak of rich ore in the middle of the dike, and replacing its substance with galena.

A section of the Yuba dike deposit at the Pacific tunnel shows a smooth slickensided quartzite footwall, above which is a foot to 18 inches altered porphyry carrying disseminated lead-carbonate ore. A little past the center of the dike is a wider zone of fissuring and replacement that is 2 to 10 feet thick, accompanied with smooth, slickensided walls, and along the smooth slips kidneys and small lenses of friable quartz and clean, hard, carbonate ore occur, containing 50 per cent. lead, 200 to 300 ounces silver, and \$20 to \$30 gold per ton, while balance of the space is filled with white, chalky, kaolinized porphyry gangue, and disseminated sandy carbonate of lead, constituting a first-class concentrating ore containing average values of 2 to 8 per cent. lead, with 3 to 4 ounces of silver and 50-cents gold to each unit of lead. A similar altered porphyry ore zone follows the smooth quartzite hanging wall of the dike at this point, and I was informed that in the adjoining Yuba shaft workings in places diagonal stringers of rich ore connected the two south ore courses and commercialized the whole body from 10 to 20 feet wide.

These porphyry ore bodies are dry, stand well with little timbering, and owing to the light, chalky nature of the gangue, the lead and most of the silver and gold are readily recovered by ordinary wet methods of concentrating, and whatever silver chloride and fine gold escape into the tailing can be readily recovered by leaching.

Method of Smelting With Oil

Heat Generated Outside the Stack and Only Enough Coke Used to Reduce the Oxides

This article was written with a view to using petroleum as a blast-furnace fuel, and deals mainly with smelting concentrates, but in such smelting little slag is made in comparison with ordinary blast-furnace smelting, consequently fair criticism is invited and will be appreciated.

This article is to place before metallurgists a system of smelting ores of copper or lead carrying gold and silver, to a lead base bullion or to a copper matte, or to base copper metal. Heat for this system is produced by the use of a hydrocarbon fuel, such as petroleum, burned in a combustion chamber out of contact with the ores, instead of coke or charcoal being charged in with the ores, as in the present practice.

Oil, gas, coke, or charcoal is burned in a combustion chamber outside the blast furnace stack, and the heat generated is conveyed to the ores in the stack through suitable flues to a point immediately below the tuyeres, and such heat is subject, for intensity and quantity, to easy, absolute, and instantaneous control.

Burning coke or charcoal for the production of heat, in contact with the ores being smelted tends, in most instances, to modify the result sought when smelting ores for their gold, silver, copper, and lead, on account of the high percentage of glowing carbon, or else on account of air blown in to burn such fuel.

In the reduction of lead oxide or of copper oxide, atmospheric air or oxygen has no part, because it is the contained oxygen of these minerals that is sought to be eliminated, and any air blown in is an opposing factor.

The production of heat within the blast furnace by burning coke in contact with the ores, as in the old system, involves blowing into the furnace quantities of air which comes in contact alike with the coke, unreduced oxides, and with the reduced metal in the sublimed condition. Its mission is to oxidize, or burn the coke for the production of the heat necessary for smelting, but while it does this it also oxidizes some reduced metal and by contact with oxidized mineral it resists the reduction of such mineral to metal. It is only by the predominance of the reducing atmosphere of the burning coke in the blast furnace that the method in common use succeeds, and, manifestly, smelting is done in spite of the oxidizing tendency of free air blown into the stack. Always some of the oxidized mineral is blown upon by the air blast and so resists the reducing tendency of the furnace atmosphere, and some metal that has been reduced in the reducing atmosphere predominant is oxidized by the air blast and sent to the dust chamber, or to the slag as a silicate.

No air should ever be blown into a reducing furnace, other than the little that may be requisite for burning carbon to the monoxide to increase the reducing action of the furnace atmosphere.

A simple laboratory illustration of the reactions involved in smelting lead-gold-silver ores to a lead base bullion is to take a glass tube, seal one end and half fill it with roasted lead ore, mixed with about half its bulk of coarsely pulverized charcoal. Stop the open end of the tube, leaving a small aperture for the escape of gases. Heat the tube over a Bunsen burner until the contents are red hot, when the charcoal will have absorbed or combined with the oxygen of the ore and the lead will be in the form of metal as base bullion carrying the gold and silver of the ore. As the process goes on, the heated gases evolved flow outward at the opening in the end of the tube, thus preventing the ingress of air, and the process of reduction to metal is finally complete.

Atmospheric air, if admitted to the highly heated ore and

fuel in a blast furnace, is counteractive of the reactions involved in the ore-reducing process; and proportionately to the amount of air admitted is the result compromised by imperfect or incomplete reduction, and the reoxidizing of some of the metal already reduced in the form of vapor.

The usual method of lead smelting is subject to this adverse condition, for it is physically impossible to blow the necessary quantity of air to burn the fuel without exposing some of the already reduced metal to its direct action. Hence, chiefly, the necessity for capacious and expensive dust chambers in general use. This also is a prolific cause of lead silicates in slag.

The perfect system consists in the introduction of the necessary quantity of heat to the ore to insure the reactions involved when conditions are right; and conditions are right when the roasted ore and the necessary fluxes are introduced into the blast furnace with sufficient coke or charcoal to take up and react with the oxygen contained in the roasted ore, thus leaving the metal so reduced free to fall down into the crucible.

The ideal method of introducing the necessary heat into the blast furnace without the presence of air with its counteractive oxidizing influence is to burn petroleum or other hydrocarbon in a combustion chamber and to conduct the heat so generated, together with the gases of combustion, through suitable flues into the blast-furnace shaft, and thus into contact with the ore to be smelted. The roasted ore is heated then to the smelting temperature and the desired reactions secured without any possible contact with the atmospheric air.

The small amount of coke or charcoal charged into the furnace should be just sufficient in proportion to furnish carbon to combine with the oxygen of the ore; more than this would be waste of material. The exact proportion of coke or charcoal necessary for this purpose is readily calculated.

The following illustrates a typical instance of such calculation: Assuming 1,000 pounds of charge with 15 per cent. lead and 30 per cent. iron in the charge, the lead as oxide, PbO , in a roasted lead ore, and the iron as ferric oxide, Fe_2O_3 , in the form of hematite added as flux. Then 207 parts by weight of lead combine with 16 parts by weight of oxygen; therefore, $150 \times \frac{16}{207} = 11.6$ pounds oxygen combined with the lead; 12 parts by weight of carbon combine with 32 parts by weight of oxygen; therefore, $11.6 \times \frac{12}{32} = 4.35$ pounds carbon, are necessary to combine with the oxygen in the PbO .

The iron being in the form of Fe_2O_3 must be reduced to ferrous oxide, FeO , to combine with silica to form slag. In Fe_2O_3 there are 112 parts iron and 48 parts oxygen, therefore; $300 \times \frac{48}{112} = 129$ pounds total oxygen in the hematite; one-third, or 43 pounds, of which must be combined with carbon to reduce the Fe_2O_3 to FeO to combine with the silica and form slag. As 12 parts of carbon combine with 32 parts of oxygen, it requires $43 \times \frac{12}{32} = 16.12$ pounds of carbon to reduce the 300 pounds of Fe_2O_3 to FeO .

This makes $4.35 + 16.12 = 20.47$ pounds carbon necessary for each 1,000 pounds of charge, to which, if coke is used, add 16 per cent. to cover ash, moisture, and waste, making a total of 23.74, practically 24 pounds of coke to 1,000 pounds of charge, equal to 2.4 per cent. of the weight of the charge, for absorbing the oxygen in the roasted lead ore and reducing the lead, and in combining with the excess oxygen in the hematite to reduce it to FeO . Charcoal is the preferable form of carbon for this purpose, and about 2 per cent. of the weight of the ore charge is required, on account of its less percentage of ash, than assumed for coke.

Carbon dioxide, incident to burning petroleum in a combustion chamber, passes into the blast furnace and comes

in contact with the glowing coke or charcoal, insuring the reduction to carbon monoxide of any such carbon as may have escaped contact with roasted ore at combining temperature. This CO gas permeating every space and coming in contact with every particle of the roasted ore, insures complete reduction of the oxidized lead ore to metal.

The same results may be attained as effectually without the use of coke or charcoal charged with the ore, by simply blowing into the combustion chamber an excess of oil over the equivalent of oxygen necessary for its complete combustion, thus generating any proportion of carbon monoxide in the furnace that may be necessary for the complete absorption of the oxygen in the roasted ore. This latter method, however, is not susceptible of so easy and accurate regulation, unless by the use of an entirely independent apparatus for injecting a predetermined quantity of the hydrocarbon to the smelting zone of the furnace shaft.

If the ore to be smelted is an oxide or carbonate of copper, the smelting process is the same as above and the product is black copper, carrying whatever gold and silver is in the ore.

In case sulphide-iron-copper ores carrying gold and silver are to be smelted to a copper matte, the process is modified by omitting the reducing agent. As in the foregoing case, the heat generated in a combustion chamber by burning petroleum or other hydrocarbon there, is passed with the gaseous products of such combustion, through suitable flues directly into the blast-furnace stack and thus into direct contact with the ores to be smelted, imparting to them the necessary heat, and the smelting process at once goes on. If the ore charge carries no more sulphur than is necessary for the matte, then no free air is blown into the blast furnace. If otherwise, and there is an excess of sulphur with its combined iron, then sufficient air must be blown into the blast furnace in the usual way to oxidize the sulphur.

A large amount of heat is produced in oxidizing the excess iron and sulphur in the ore and the amount of heat necessary to be produced from petroleum in the combustion chamber is reduced, and a saving of fuel is effected, the ultimate calorific value of the surplus iron and sulphur being utilized in the smelting operation, which proceeds with certainty and regularity unknown to other methods.

Supports for Feed Wires

At the Robison mine, of the C. F. & I. Co., Walsenburg, Colo., the method of supporting the feed wires upon the timbers having proved unsatisfactory, Mr. John Graham, superintendent, has used the following with satisfactory results. Having a considerable amount of 2-inch old iron pipe on hand this was cut into 5-foot lengths and bent into the shape shown in Fig. 1; the holes for the four porcelain insulators being drilled or punched as found convenient. After being set in holes drilled in the rib for the purpose the legs of the brackets were cemented in place.

In order to drill the holes, an ordinary post drill was mounted so as to be adjustable for height on the planking of a mine car on the side opposite to that on which the brackets were to be placed. The car, after having been loaded with brackets and cement sufficient for a shift, was dropped down the slope and stopped wherever necessary to drill the holes.

Aside from being an ingenious method of working up old material and of assuring the placing of the brackets at a uniform height above the rail, the system of doing the work cannot be too highly commended. By mounting the drill on the car, no labor is lost in moving it from place to place, and the material being in the "drill car" is where wanted when needed and time is not wasted in looking it up, as is too often the case.

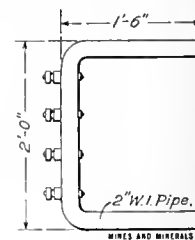

Fig. 1

Surveying and Sampling Drill Holes

Methods of Determining Course of Hole and Methods of Sampling Cores and Drill Sludge

In a paper read before the Lake Superior Mining Institute, at the August, 1911, meeting, E. E. White, after referring to previously described methods of controlling the curvature of diamond-drill holes, and the determination of their inclination by hydrofluoric acid tests, described the methods that have been developed by the Cleveland-Cliffs Iron Co. in the Lake Superior district, as follows:

After considering several methods of determining the course, as well as the inclination of drill holes, two were chosen for trial, one of which has proved satisfactory, the other moderately so. In non-magnetic rock formations the old method of a compass suspended in gelatine is successfully used with improvements worked out by Mr. George Maas and myself. Mr. Maas has patented his improved compass and his idea of using a thermos bottle in connection with the compass and gelatine. In magnetic formations a method of marking the drill rods is used in connection with hydrofluoric acid tests. This method was described to Mr. J. E. Jopling by Mr. John Deacon, superintendent of the Republic Iron and Steel Co.'s properties at Negaunee, who used it in testing diamond-drill holes at the Cambria mine. We did not find it as successful as using a compass, but it is the only method which I know that is practicable in magnetic formations.

Surveying in Non-Magnetic Formations.—Figs. 1 and 2 show the cases used to test for inclination and course. The latter shows the case used when it is desired to make more than one test at the same time, as it may be inserted at any point in the drill rods at the same time that the first case is used at the end of the rods. As it is desired to use as large a glass tube in the case as possible, and as the outside diameter is limited by the size of an "E" hole, a material was selected which combined the greatest possible toughness and tensile strength with non-magnetic properties. Phosphor bronze was chosen, which is entirely non-magnetic, and for which the manufacturers guarantee a tensile strength of 70,000 pounds and elastic limit of 55,000 pounds per square inch. By using a case of dimensions given in Fig. 1, a glass tube $1\frac{1}{8}$ inches outside diameter can be used, and according to Nystrom's formula for the collapsing strength of small tubes $P = \frac{4Tt^2}{fdVL}$, using a factor of safety of 4, this case should be safe in a hole 3,300 feet below water level. A little wicking is used to make a perfectly tight joint.

The compass invented by Mr. Maas is shown in Fig. 3. Its advantage over the old forms of compass used for this purpose lies in the fact that it is pivoted in a cage which prevents its coming in contact with the glass tube and insures its swing-

ing freely in the gelatine. The cage is below and rigidly attached to the float, which is made of cork.

The most accurate and satisfactory method of testing the course of a hole is to use the compass in a glass tube open at each end and about 6 inches long. A section of rubber stopper is forced into the tube, leaving about $1\frac{1}{2}$ inches for acid at one end and 4 inches for gelatine at the other. A small weighed portion of dry gelatine is carried to the drill and dissolved on the ground in a certain quantity of water, care being taken that the water has no chance to evaporate while dissolving the gelatine. The proportions are so chosen that when dissolved the solution will keep liquid as long as possible after being lowered in the drill hole and yet will become perfectly solid when cold. For instance, using Nelson's improved brilliant gelatine we use 5-6 gram and dissolve it in 50 cubic centimeters of water. In a hole where the rods can be lowered in 20 minutes or less, a $1\frac{1}{8}$ -inch tube is used with paper wrapping. When it

takes from 20 to 30 minutes to lower the rods a 1-inch tube is used with several wrappings of paper. If deeper than this, a thermos bottle is used, and by using a paper wrapper the gelatine may thus be kept liquid 50 minutes. The time the gelatine remains liquid was determined by tests in ice water at 43° F., which is the temperature of the underground water.

In the first two cases when the thermos bottle is not necessary the dissolved gelatine is poured into the tube and heated as hot as possible by immersing the tube in water heated to boiling by live steam. When hot the compass is dropped in and a stopper placed in that end, then about 1 inch of dilute

hydrofluoric acid is poured into the other end and that end closed. The tube is then wrapped in paper and placed with gelatine end up in the bronze case, which is attached to the bottom of 20 feet of brass "E" rods and lowered into the hole, losing as little time as possible. The brass rods are screwed to the bottom of the regular drill rods, an "A" to "E" reducing coupling being used if the hole is being drilled with "A" rods. The bronze case and brass rods are made for an "E" hole so that they can be used in either case. If two tests are to be made at the same time, another tube and compass are placed in the case shown in Fig. 2 and inserted in the drill rods at the proper point, using 20-foot brass rods on each side.

The tube is left stationary in the hole 50 minutes after the rods are lowered, giving the gelatine time to cool and set and the acid time to etch a good line. It is found that acid diluted with 12 parts of water gives best results. It is diluted in the office and carried to the drill in hard rubber bottles with screw tops, which are much more convenient than the paraffine bottles used at first.

When the tube is brought to surface the positions of the north and south ends of the needle are marked on the glass with a diamond point and the tube washed out and the compass dried to prevent rusting. This tube forms a permanent

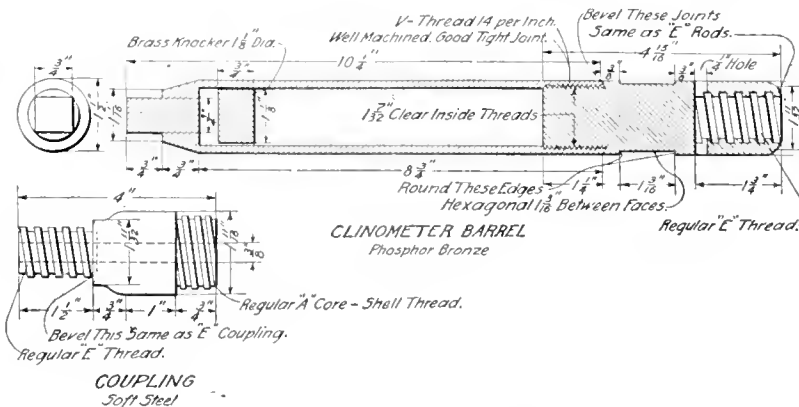

FIG. 1. DRILL HOLE CLINOMETER

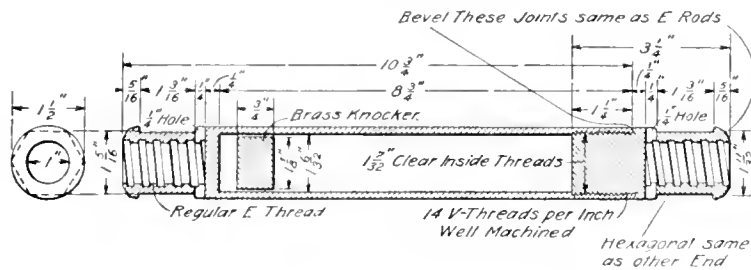

FIG. 2. PHOSPHOR BRONZE DRILL HOLE CLINOMETER

record of the inclination and course of the hole at the depth at which the test was taken.

The thermos bottle is $1\frac{1}{2}$ inches outside diameter and composed of two clear glass walls with a vacuum between, as shown in Fig. 4. When it is necessary to use this the hot gelatine

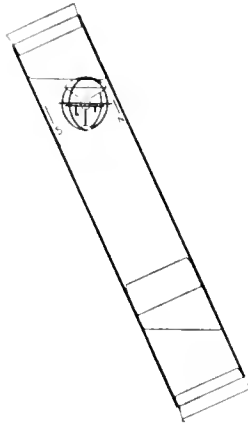

FIG. 3

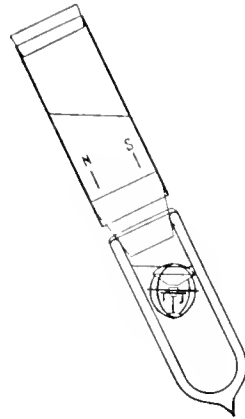

FIG. 4

and compass are placed in the bottle and the bottle closed by a rubber stopper. The stopper also closes one end of a $1\frac{1}{8}$ -inch tube 3 inches long, serving to connect the bottle and tube and preserve them in the same relative position, as shown in Fig. 4. Dilute acid is placed in the tube, the other end

over night, however, but in that case the acid is diluted more. When the tube is brought to surface the north and south points are marked on it, corresponding to the position of the compass needle in the thermos bottle. The tube then forms a permanent record of course and inclination just as the 6-inch tube does.

In either case the inclination is read in the goniometer described and shown by J. E. Jopling in the Transactions of the Lake Superior Mining Institute for 1909, and is corrected for capillarity according to a curve which is prepared for each size of tube, by testing tubes at known angles according to the method described by Mr. Jopling. Fig. 5 shows a curve for $1\frac{1}{8}$ -inch tubes. It will be noted that for these larger tubes the correction is only $3\frac{1}{4}$ degrees at 45 degrees, which is the max-

Curve of Correction For Error Due to Capillarity in Testing Diamond Drill Holes Curve for Tubes

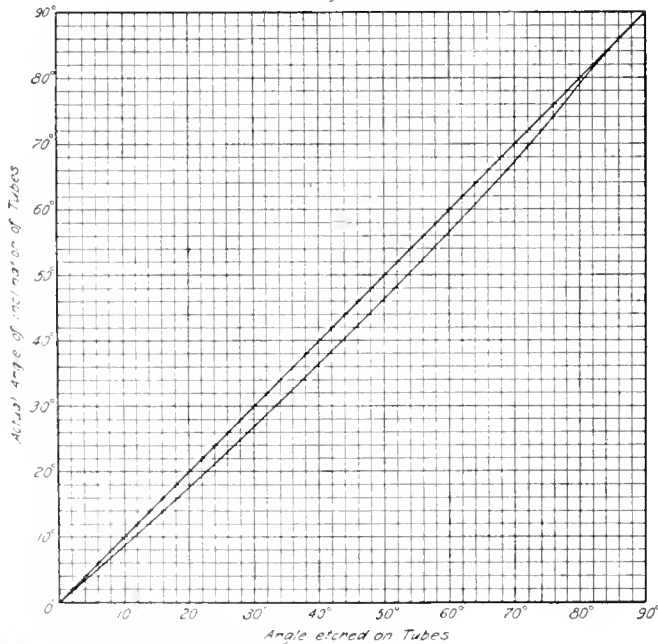

FIG. 5

closed, and the tube and bottle placed in the bronze case and lowered into the drill hole. It only takes the gelatine $1\frac{1}{2}$ hours to solidify in the thermos bottle, so that it is usually left in the hole only 50 minutes after the rods reach the bottom, just long enough to get a good etching. It may be left in the hole

The Cleveland-Cliffs Iron Company ISHPEMING, MICHIGAN RECORD OF DIAMOND DRILLING

--- SHIFT --- 191---

Where Working _____

Section _____ Hole No. _____

	Feet	Core Saved	Hours
Total depth of hole per last report			
Moving and setting up			
Drove _____ inch stand pipe			
Drilled with chopping bit			
Drilled with diamonds			
Reamed from _____ to _____ ft.			
Lowered _____ inch casing to _____ ft.			
TOTAL DEPTH OF HOLE			
Kind of Material _____			

	Feet	Size	Hours
Bit No. _____			
Bit No. _____			
Bit No. _____			

Number of Men _____

REMARKS _____

_____ Runner

_____ Helper

_____ Setter

_____ Foreman

Report delays, accidents, etc. _____

FIG. 6

imum. The angle can be read to $\frac{1}{2}$ degree and I feel certain that the results of tests for inclination can be relied upon to within 1 degree.

To determine the course of the hole the tube is placed in the goniometer with the graduated circle set at 0° so that the tube is vertical. If the inclination of the hole is steep the tube is twisted until the etching shows the dip to be either directly toward or away from the eye; that is, until the cross-thread bisects the ellipse etched on the glass. If the inclination is shallow it is more accurate to twist the tube so that the dip is to the right or left of the observer and in the plane of the graduated circle. The goniometer is next placed on a protractor so that the tube comes vertically over the center, and, by sighting down over a straightedge placed in line with the north and south points marked on the tube, the point of

the compass toward which the hole dips may be determined. Figs. 3 and 4 show tubes with acid, gelatine, compass, and north and south points marked, just as they are taken from the drill hole. I intend to have another goniometer made with horizontal circle to measure the course as well as vertical circle for the inclination, but have not had an opportunity to do so as yet.

We have found the method described above very successful, and two tests at the same point almost always agree. When

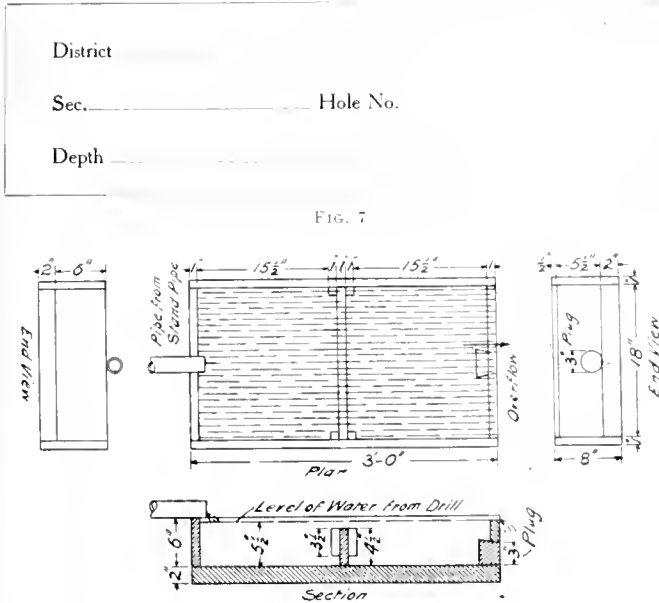

FIG. 8. SLUDGE BOX

this is not the case more tests are made, and so far we have always been able to ascertain which are wrong. We have made tests at a depth of 2,000 feet, but it would probably be difficult to go much deeper without using more insulating wrapping around the thermos bottle than is possible with a bottle and case of dimensions now used.

The precautions to be taken are three in number: (1) That the compass swings perfectly free, that is, that it does not catch on the cage and that the gelatine keep liquid long enough; (2) that there is no local magnetic attraction in the rock formation; (3) that the compass is not affected by the steel drill rods or casing or by other iron in the hole. The first precaution is easily taken; the second can only be judged by a knowledge of the formation and by taking tests at different depths. If these are concordant there is probably no appreciable magnetic attraction. The third precaution is important. We use 20 feet of brass rods and so have no iron within 20 feet of the compass. Tests with 10 feet, 20 feet, 30 feet, and 40 feet of brass rods at the same depth gave the same reading in a hole dipping 50 degrees north 45 degrees east, so that 20 feet is conservative.

Surveying in Magnetic Formations.—When the rock formation is known to be magnetic, or when several tests with the compass do not agree, there seems to be no way of determining the course of a hole but by lowering the rods in such a way that the test tube can be oriented at any point in the hole. We have done this by the method suggested by Mr. Deacon. The rods are first screwed together in one or two long lines on the surface just as they will be lowered into the hole, with the bronze case at the end, all the joints being made as tight as usual. Great care is necessary that no twist be left in the rods when screwing them together on the ground. This trouble is not experienced when there is snow, as the rods slip easily on the snow and no torsion can be introduced. When the ground is bare it may be avoided by placing level planks at short intervals for the line of rods to rest upon and not allowing them to touch the

ground at any point. If not over 500 feet in length the rods will turn on grass without leaving any twist in the rods.

When all connected, each joint that is to be broken, usually every second joint, is marked with a chisel so that it can be screwed up again to exactly the same place. They are marked exactly on top as they lie on the ground, so that when the rods are in the hole the marks will point in exactly the same direction. The joints are then broken, being careful not to disturb any joints which are not marked.

Dilute hydrofluoric acid is poured into a glass tube and the tube marked with a diamond and placed in the bronze case so that the mark on the tube corresponds with that on the case. The tube is then lowered into the hole, being careful to exactly match the marks at every joint. The mark on the last rod is placed directly in front of the drill and this direction determined, which is the direction of the mark on the glass tube. The tube is left stationary at the bottom of the hole for about 50 minutes, when acid diluted 12 to 1 is used, and then withdrawn and washed. To determine the course of the hole another mark is made exactly on the opposite side of the tube and the course found by using the goniometer and protractor, as described in connection with the gelatine test.

This method of course only gives accurate results when the rods turn easily in the hole so that there is no twist in the rods when lowered. This is usually the case except in very deep holes or where the inclination is low or where the curvature is excessive. In these cases, unless the hole is rifled, the twist may probably be removed by raising and lowering the rods several feet a few times after the rods are in the hole. Precaution should be taken

THE CLEVELAND-CLIFFS IRON CO.

DAILY REPORT OF DIAMOND DRILLS

ISHPEMING, MICH.,

191

Section	Hole No.	Date	Feet Drilled	Total Depth	Material	Remarks

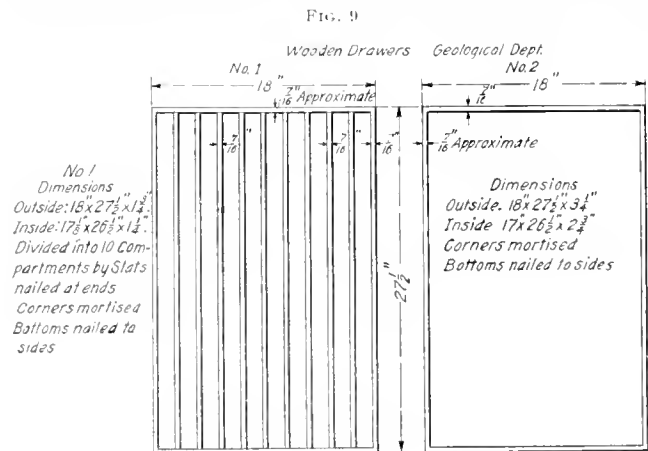

FIG. 10

that the tube cannot turn in the bronze case, either by wrapping with paper or by using a stopper which fits the case snugly. Our tests by this method do not always agree, and are apt to be 10 degrees or 20 degrees anticlockwise from the course as determined by compass in a non-magnetic formation. One reason for this seems to be that in lowering the joints the rods work tight or loose because of the friction of the rods revolving in the hole.

Daily Reports.—Fig. 6 shows a report form filled out by the drill men every shift for the drill foreman and the head office,

and Fig. 7 a sample tag which is placed in every bag of core or sludge. The record of time of drilling and footage of each diamond bit is kept to obtain data on the several stones in the bit with the idea of determining which are the most economical. These tests have shown that the wearing quality of the stone depends considerably upon the specific gravity and upon the structure.

Although it is important to have the drillmen report the amount of core saved from each material, yet they rarely measure it accurately, and if the analyses of core and sludge are to be combined, as described below, the core is remeasured when it reaches the office.

The following directions for saving samples are posted in the drill shanties and enforced by the inspector:

Directions for Saving Sludge From Diamond-Drill Holes. Set the standard sludge box just below the floor of the shanty and in such position that there is room to siphon off the water and take out the sample without moving the box. Connect a T to the top of the standpipe or easing and lead a pipe from

to the sludge box must be cleaned out into the sludge box and either the pump must then be stopped or the T turned so that the water will not be discharged into the box. Carefully remove the partition in the box so as not to stir up the sludge any more than necessary; and when the sludge is settled, siphon off the surplus water, being careful to keep the end of the siphon near the surface of the water and not disturb or draw off any of the fine sludge at the bottom of the box. To use the siphon, fill with water a 3-foot length of large size flexible hose, and with one hand on each end place one end beneath the surface of the water in the box and the other end on the ground 8 inches or more below the top of the box. When both ends of the hose are released the water will flow out of the box and may be allowed to flow until it is seen that the sludge is beginning to go off with the water. Then remove the hose and thoroughly mix the sludge in the box to a mud. This must all be removed from the box and placed in a pan on the boiler to dry. The pan must be at least 8 in. X 12 in. X 1 in. deep, with flat bottom, and must be thoroughly cleaned

THE CLEVELAND-CLIFFS IRON CO.
RECORD OF DIAMOND DRILLING

Hole No. _____
Sheet No. _____

District } _____
Mine } _____ State _____ T. _____ R. _____ Sec. _____ Hole No. _____ Location: _____
Dip: _____ Course: _____ Drilled by whom _____ with _____

DATE	No. Hours	CORE RECOVERED		Stand Pipe	Drilled	Total Depth	KIND OF MATERIAL	Begins at	Dip of Strata	REMARKS
		Ft.	In.							

FIG. 11

THE CLEVELAND-CLIFFS IRON CO.
ANALYSIS OF CUTTINGS AND CORE

District } _____
Mine } _____
Option } _____ State _____ T. _____ R. _____ Sec. _____ Hole No. _____ Location _____
Lease } _____ Determined by _____ 191 _____ Elevation of Collar _____

From	To	Iron	Phos.							

FIG. 12

it to the nearer end of the sludge box, at such a height that it will either be level or slant toward the sludge box and just rest upon the top of the box, and of such a length that it will not project more than 1 inch beyond the edge of the box. The pipe must not be more than 2 feet long, and if longer than 1 foot must be split on top for the foot nearest the sludge box, so that if sludge collects in the pipe it may be seen. Set the box level so that water will overflow evenly across the whole width at the far end, and wedge the partition firmly so that it is in close contact with the bottom of the box. The top of the partition should be 1 inch below the water level. The box is now ready to receive the sample, and drilling may be started.

While drilling, care must be taken that no water from the drill hole escapes around or over the T except through the pipe leading to the sludge box. Care must also be taken that there is no leak from the box and that the 3-inch plug at the end of the box is tight. Sludge samples must be taken for every 5 feet drilled or less, preferably from even 5-foot intervals; that is, from 460 to 465, 465 to 470, 470 to 475, etc.

When a sludge sample is to be taken drilling must be stopped and the hole washed out clean. The pipe leading

each time before a sample is put in it to dry. If enough water cannot be drawn off without disturbing the sludge so that the sample can be contained in this pan, a larger pan must be used. All the sludge must be saved and the sludge box cleaned thoroughly. When the sludge has been cleaned out, remove the 3-inch plug at the end of the box and wash out the box with a pail or two of water, then replace the plug and partition and drilling may be started again.

The sludge must be labeled, giving the depths between which the sample was taken, when it is placed on the boiler to dry. It must all be saved and turned over to the inspector. Sludge must always be saved when drilling in iron formation or in any other ferruginous or red material. While drilling in material from which a sludge sample should be saved, if the water is lost, if the sludge does not come up with the water, or if the sludge is contaminated with material caving from higher up in the hole, drilling must be stopped immediately until the hole is put in such condition that good sludge samples can again be obtained, or until the inspector gives orders that drilling may proceed.

Whenever the drill runs into or out of ore, provided the

band of ore or rock is 1 foot or more thick, drilling must be stopped and the sludge box cleaned out immediately, without waiting to complete the 5-foot run. When the drill runs out of ore, continue taking and saving sludge samples for at least 20 feet, no matter what the material, so that it may be determined whether the ore is caving.

Keep the core separate from the sludge, and each time core is pulled label it with the depths between which it was recovered. Each run of core must be kept separate and all core must be saved and turned over to the inspector. When the core is pulled, if it is found that more core is saved than the proportion of 1 foot of core to 10 feet of drilling, the sludge box must be cleaned without waiting to complete the 5-foot run, and the sludge labeled and saved separately. If sludge from a shorter distance than 5 feet is in the box at the end of the shift's work, and if less than the above proportion of core is saved, the sludge may be left in the box provided the shanty is locked and the box is inaccessible from outside the shanty. If anybody can get at the box, however, and if there is no watchman, the sludge must be removed from the box, dried, labeled, and placed with the other samples.

The standard sludge box is shown in Fig. 8.

When the samples reach the office they are carefully examined and a daily report of all drilling made out on the

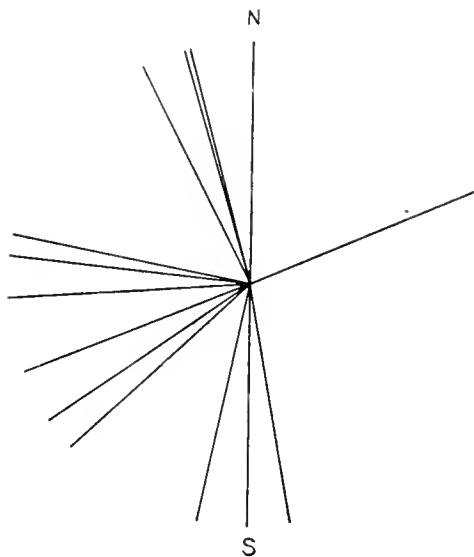

FIG. 13

form shown in Fig. 9. Samples of all core and of all sludge which runs above 40 per cent. iron are preserved in a room and in cabinets designed especially for the purpose. A few pieces of core are saved from every run and the rest sent to the laboratory for analysis if ore formation, or thrown away if not. A little of each sludge sample is placed in a small pasteboard tray with a temporary label, 10 feet to a tray, until the analysis is complete. Each 10 feet of sludge sample which runs over 40 per cent. is then placed in a gelatine case and preserved in the same drawer with the ore. Gummied paper labels are used for both core and sludge and the samples preserved in the drawers shown in Fig. 10.

Interpretation of Analyses.—Mr. W. J. Mead has described our method of combining core and sludge analyses in an article in the *Engineering and Mining Journal*, of May 6, 1911, except that we used a formula in the method which I described to Mr. Mead several months ago instead of the diagram which he has developed from it. Since other engineers may also be interested in the formula, I give the derivation below:

- Let A = diameter of bit outside of carbon;
- B = diameter of bit inside of carbon;
- C = feet of core saved in " D " feet drilled;
- D = feet drilled;

S = volume of rock actually ground to sludge;
 T = volume of rock actually saved as core.

Then,
$$S = D \left(\frac{\pi A^2}{4} - \frac{\pi B^2}{4} \right) + (D - C) \frac{\pi B^2}{4}$$

and
$$T = C \frac{\pi B^2}{4}$$

Hence,
$$\frac{S}{T} = \frac{D(A^2 - B^2) + (D - C)B^2}{CB^2} = \frac{DA^2}{CB^2} - 1$$

DIMENSIONS OF BITS

	Inside of Carbon	Outside of Carbon
Standard "A" bit	1"	1 ¹³ / ₁₆ "
Standard "E" bit	²⁷ / ₃₂ "	1 ⁹ / ₁₆ "
Hence for an "A" bit	$\frac{S}{T} = \frac{1.813D^2}{C} - 1 = 3.29 \frac{D}{C} - 1$	
and for an "E" bit	$\frac{S}{T} = \frac{1.563^2 D}{.844^2 C} - 1 = 3.43 \frac{D}{C} - 1$	

To obtain an average of the sludge and core analyses giving the proper weight to each, the sludge analysis should evidently be multiplied by S and the core analysis by T , and the sum of the products divided by $S + T$. The result is the same and the

operation simpler to multiply the sludge by $\frac{S}{T}$ and the core by 1 and divide by $\frac{S}{T} + 1$; hence, the rule for an "A" bit is to mul-

tiple the sludge analysis by $3.3 \frac{D}{C} - 1$, add the core analysis, and

divide the sum by $3.3 \frac{D}{C}$. Since the core is rarely pulled in 5-foot runs we find it just as simple to figure the ratio from the formula as from Mr. Mead's diagram.

Mr. Mead did not mention the method of obtaining the average analysis which he formerly used, namely, to weigh out proportionate parts of core and sludge and combine them for analysis. This method is ingenious but is open to objections: (1) If it is found later that the hole was caving and the sludge of no value the core analysis is also rendered valueless; (2) in order to get true analyses it is advisable to send the whole sample for analysis except a small portion kept for record, whereas if weighed out, a portion must be rejected.

We only run iron on the 5-foot samples, with phosphorus if over 40 per cent. iron, and manganese if there may be over 1 per cent. or 2 per cent. We occasionally combine several of the 5-foot sludge samples and make a complete analysis for iron, phosphorus, silica, lime, magnesia, alumina, manganese, sulphur, titanium, and loss by ignition.

After combining the core and sludge analyses the results are further averaged in continuous runs of ore of the same grade. We call from 45 per cent. to 50 per cent. iron lean ore, 50 per cent. to 57 per cent. second-class ore, and above 57 per cent. first-class ore.

Representation of Results.—As soon as possible after the first of the month the record of material drilled through the previous month is compiled from daily reports and averaged analyses. This is carefully checked over with the core and then recorded permanently in the drill book. This is a loose-leaf book with pages shown in Figs. 11 and 12. The reports of the drillmen and analyses of samples are copied in this book daily and it forms the complete and permanent record of drilling. From this book tracings are plotted which are blueprinted for the various parties entitled to receive the information. Figs. 14 and 15 show the printed forms on tracing cloth used for this purpose. They are of the same size as the loose-leaf sheets in the drill book and are bound in covers of the same size.

Cross-Sections of Drilling.—For scientific location of drill holes cross-sections must be made through previous drill holes, preferably at right angles to the strike of the formation, showing the holes plotted according to the surveys for inclination

and course, and showing the material encountered. We make these on cross-section tracing cloth ruled in inches and tenths, on a scale of 50 feet to the inch. The sections may be superposed and compared, and the cross-section ruling makes it easy to read distances and areas without a scale. On these tracings the geological boundaries of formations and the outlines of ore bodies are drawn in soft pencil, which prints satisfactorily but may easily be erased and changed if further drilling shows the first assumptions to be wrong. When necessary longitudinal sections are made and taken in connection with a plan and cross-sections give a very good idea of the structure.

Deflections of Drill Holes.—In an article written for the *South African Mining Journal* of June 11, 1910, and again in an article in the same journal of March, 1911, Mr. J. S. Curtis gives an interesting theory of the cause of bore-hole deflections with results of experiments which he made to substantiate his theory. He endeavors to show that the influence of terrestrial magnetism should cause vertical drill holes to deviate to the north in the Southern Hemisphere, and states that this is the case in the great majority of holes, although the direction may be changed by the character of the country rock.

In our experience the latter feature is much the more important and from results of our drilling I should not say that the great majority of drill holes deviate either north or south in all districts. If the strata are flat and uniform the holes

may do so, but if the strata dip steeply this is not the case. In one district where the dip is steep we are certain of the course of 14 holes which deviated from the vertical and these are shown in Fig. 13. Of these holes one went approximately north, one approximately south, one northeast, five northwest, one southeast, and five southwest. Putting it in another way, seven deviated to the north and seven to the south, while two deviated to the east and 10 to the west.

If these results show anything they only show that the majority of the holes deviated to the west, but equally to the northwest and southwest.

It is very difficult to keep vertical diamond-drill holes straight and I believe that a hole can be located with more assurance of striking a certain point in depth if it is given an inclination of 85 degrees against a steeply dipping formation than if it is started vertical. We have only drilled two holes with this inclination, with the results as in Table 1.

These two holes are not enough to generalize upon, but they certainly keep straighter than vertical holes in the same district. In addition to that we knew in which direction the holes were going, which we do not know when we start a vertical hole. In my article in the *Engineering and Mining Journal* of September 17, 1910, I gave a series of curves showing the curvature to be expected in an inclined hole when dipping against a steep jasper formation. I would change the curve for a hole started at 85 degrees,

as that seems to be a critical angle under these conditions and the hole does not flatten as would be expected.

In view of the sometimes surprising curvature of drill holes I feel that all holes should be tested for both course and inclination at 100 feet or 200 feet intervals, whether started vertical or at an angle, otherwise there is no telling where the ore or other strata cut really occur. We recently started a vertical hole which at a depth of 800 feet was found to have an inclination of only 51 degrees from the horizontal. Another hole started at an angle N 54° W was found to be running N 64° E at the bottom.

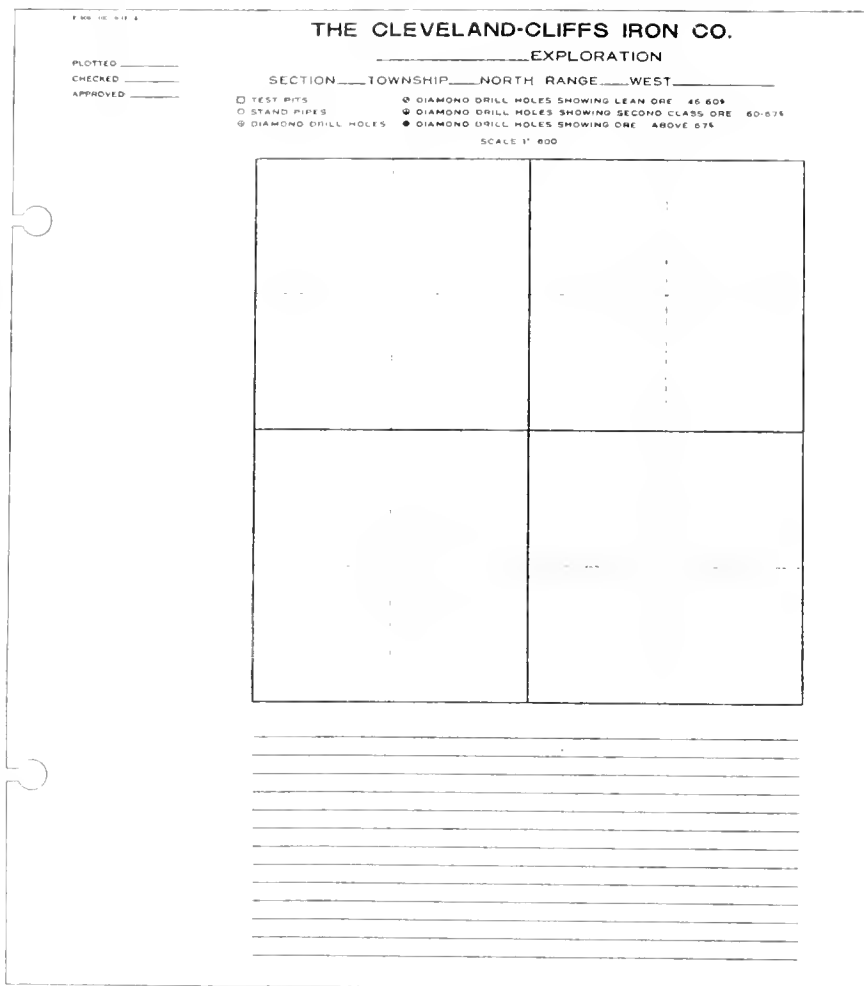

FIG. 14

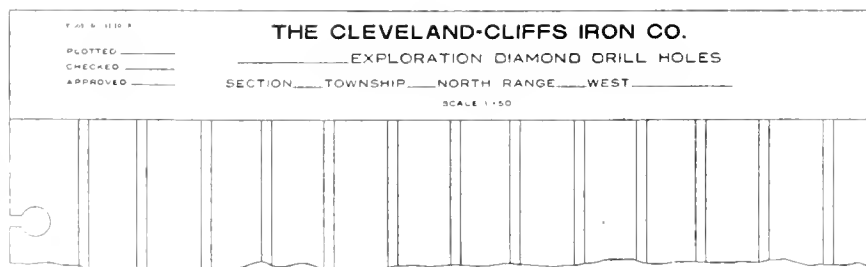

FIG. 15

TABLE 1

Depth Feet	No. 1 Degrees	No. 2 Degrees
At surface	85	85½
At ledge	86	86½
200	86	
400	85	87½
500	87½	
600	87	
800		88½
1,200		85½

Ore Mine Inspection in Missouri

Progress Made in Reducing Mining Risks by Inspection.
Peculiar Dangers in Zinc Mines

By Lucius L. Wittich

In no other mining district, perhaps, is the problem of efficient inspection so difficult of solution as in Southwest Missouri, where hundreds of mines must be visited, and where the possibility of fatal accidents is intensified through the fact that virtually all of the operations are of a temporary nature, the result being that careless methods are often pursued.

The zinc-lead mines of Southwest Missouri extend to the border line of Kansas, where inspection of metal mines is lax, and the contrast between conditions in the two states is rather startling. Kansas spends large sums in protecting the lives of her coal miners, but the vigilance does not extend to the extreme southeastern corner of the state, where zinc and lead are produced from properties that would be closed in the twinkling of an eye were the same care exercised that is manifest in the coal-producing areas. The careless, haphazard method of development is found so long as one keeps over the line in Kansas. Cave-ins are numerous and serious accidents, considering the number of mines in operation, are more numerous in Kansas than in Missouri. In the two states geological conditions are the same; formations of ore deposits are identical; zinc blende brings as much in Kansas as in Missouri; lead is worth just as much in one state as in the other; market conditions that prevail in Missouri hold good in Kansas; mining costs are virtually the same in both states; in fact, the district is as one, save for the hypothetical line that divides it and save for the various state laws that have made conditions different. Through legislation, mining conditions have been made excellent in Missouri while in Kansas little or no effort has been made to improve the situation. With the fact established then that precautionary measures are productive of good results, and that state laws and conscientious inspection can work wonders in safeguarding human life, methods by which these ends are attained may prove examples from which other operators can secure beneficial ideas.

Fifty-one miners were killed in the Joplin district mines in 1909. Improved conditions resulted in the list of fatalities being reduced to 32 in 1910. Less than 12 have met death up to date this year, and unless some unforeseen calamity occurs, the death record this year will be the lowest in years.

Falling boulders and slabs and premature explosions led the list. To prevent death from falling roof is largely a problem of precaution. Where proper care is given to the excavation of drifts, the possibility of such mishaps is reduced to a minimum. Premature explosions often can be attributed to carelessness,

therefore operators should employ only trustworthy men to handle explosives. Recently enacted state laws regulate the handling of explosives, a feature of the new bill being that only a 24-hours' supply of powder shall be kept underground at one time. Whether or not such a state law is in existence, a mine operator should observe this rule, which is one of common sense. It should be as easy to keep mines in good condition in a state where the laws are lax as in one where the laws are rigid, but the operator unhampered by the suggestions of an ever-inquisitive inspector, often fails to keep his mine in a safe working condition; and forgetful of the safety of his employes, is occupied entirely in producing the greatest volume of concentrates at a minimum expense.

The hazards of mining begin when the miner steps into the tub to be lowered to his day's work. In 1910, three men perished in the Joplin district from falling from tubs, either in being hoisted from the ground, or in being lowered. One perished from walking up on a "boulder pop," for which, of course, the mining company was in no manner responsible. Proper knowledge of the nature of high explosives, however, would have been invaluable to the victim. Three men were killed from falling material in shafts, the carelessness of hoister men and of the victims themselves being jointly responsible for such disasters. Three were killed by foul air, caused by failure to blow out the gaseous fumes after firing holes in a winze. Other miscellaneous catastrophes made up the total of 32 for the year. Serious non-fatal accidents numbered 23, a material decrease from the previous year's statistics. In the non-fatal accidents, falling slabs caused six, squib shots caused five, careless hoister men who dropped men into shafts caused two, mistakes in signals to hoister men, causing men to be bumped against the sides of shafts when lifted out, caused two, and the others resulted from various causes, all of which could have been avoided had proper precautionary methods been observed.

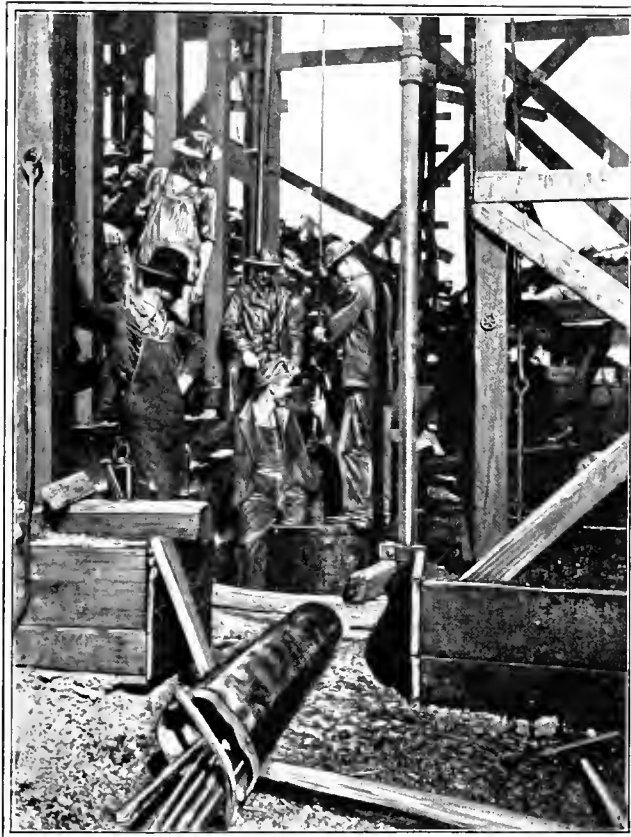

FIG. 1. LOWERING MEN IN A TUB

The number killed has been about four to each 1,000 employed, according to figures compiled for four years by the State Bureau of Mines, covering accidents in the Joplin district. These startling figures resulted in more vigorous efforts to prevent mine disasters. Human life is beginning to be reckoned as a factor far more important than the production of minerals, and the nation-wide crusade looking toward better mining conditions must of necessity bear fruit.

It is not that the mining practice is at fault in the Joplin district; because the mining practice is the result of years of experience and development not only locally but elsewhere, other methods having been found adaptable, in many cases, for use in the Joplin district. The fault is not with the practice, but with abuses of the practice. One of the first steps taken was to secure the enactment of laws that would prevent such abuses. The need of such laws was imperative, and in an address before the Joplin Commercial Club, December 17, 1909, Charles P. Wallace, urged operators to lend their influence in securing the

passage of a number of bills which later became state laws. One of these measures fixed the responsibility of the mine owner. It outlined the types of cases in which he would be held responsible for injury to his employes. It clearly defined what precautionary and sanitary methods should be employed, and thus acted as a powerful factor in influencing operators to better mining conditions. It was one of several bills enacted that looked toward conservation of the highest moral type, conservation of human life.

Twenty-five per cent. of fatal accidents, caused by falls of roof, could be classed as unavoidable; of the remaining 75 per cent., some are caused by carelessness in not properly trimming the roof; some by carelessness in not properly timbering the ground; some by carelessness on the part of men working in places known to be dangerous in order to "beat wages," but the majority by carelessness in excavating ground so wide that the roof cannot possibly stand for any length of time with the few pillars left. Pillars left to support the roof, as in Fig. 2, should be of proper dimensions to hold up the great weight above. The formation of the ground regulates to a great degree the distance at which the pillars should be left standing. In sheet ground, where the roof is of flint or cotton rock, 35 to 40 feet is considered a reasonable distance between pillars, and where the roof is from 8 to 12 feet high the pillars should average 18 to 20 feet in thickness. In the sheet-ground districts little or no timbering is required, and for this reason alone especial care must be taken to keep the roofs in good condition. In soft-ground mining heavy timbers are employed, as in Fig. 3, and these supports hold back the caving ground, but in the sheet formation no supporting timber is employed; when a boulder or slab breaks loose it comes down without warning. Sheet ground operators are beginning to realize that pillars, left in the form of the five spots on a die, are much more satisfactory than pillars left standing in even rows. It is not uncommon to find sheet-ground mines in the Webb City district where the excavations are hundreds of feet wide. As far as the eye can reach no supporting pillars can be detected. It appears that one is standing in a vast, underground plain over which stretches an endless roof of solid rock, held in place by some invisible power. But such operations are being discouraged. Operators who persist in conducting such development are forced to shut down their mines. At present, 12 producers in the Joplin and Webb City camps are idle because the inspectors have served notice that development cannot continue until certain laws are observed. Two shafts, for instance, must be connected with the drifts in cases where the inspector believes the lives of the miners would be endangered where only one shaft is used. To observe this law, companies often sink a second shaft for ventilation purposes, but more often, especially where the mill capacity is large, ore is hoisted from both shafts, as shown in Fig. 4.

Operators in the sheet-ground districts realize the danger from falling slabs. Even if they have had no bad accidents, they have been compelled from time to time to take down slab after slab of roof until the handling of so much waste has eaten up the profits for months at a time; and in some cases it will be impossible to take up stope solely for the reason that the ground was cut too wide originally. The falling of slabs is simply the result of the ground's efforts to arch itself, the roof as left by the miners having of necessity been left flat. Heavy blasting,

necessary in sheet-ground mining, also helps the natural action of the ground.

Too frequently the greed for more ore has resulted in dire catastrophes. Indirectly the fault may lie with the operator, although personally he may have little or nothing to do with the manner in which his mine is worked. The superintendent, anxious to produce results, will make the demand on the ground foreman for "more dirt," and the foreman, even though he may know that he is violating the laws of common safety, also desires to cinch his position, and it is "up to him to deliver the goods." The order for "more dirt" is passed down to the machine men and the shovelers. All may realize that the ground is being butchered, but they likewise appreciate the fact that if they do not care to do as ordered, some other man will. And so it is that there are excuses for the practice, but valid reasons are impossible to find.

Former Mine Inspector Wallace is opposed to the stope method of mining. First, ascertain the thickness of the ore deposit and plan to carry it all in one cutting, is his advice. Large pillars should be left on at least two sides of the shaft—far enough apart, or else a cutting should be made in each of them on the side next to the shaft, so that the tub hooker will have adequate room in which to work without being exposed constantly to the dangers of falling missiles from the shaft. To insure a substantial roof it is important to cut the ground

high enough to avoid the seams of ore, as these form weakened spaces between the rock and permit it to separate. By cutting the roof too high, a decomposed cotton rock is encountered, which is not substantial. After the stratum that is to be used as cap rock is selected care should be exercised to follow this stratum as uniformly as possible. The constant "burning" of the roof by holes bedded too high is a prolific source of troublesome slabs.

With the introduction of more economical milling processes each year, and with the

continuation of substantial prices for zinc ore, operators have shown a tendency to go into old worked out ground to handle thin dirt that could not have been mined profitably a few years ago. In such mines it will be found frequently that no pillars have been left, the previous operators having drawn the supports, which contained rich ore. The ground, in such cases, is treacherous, and it is necessary to employ artificial supports. Timbering at the best is a poor substitute for the original pillars of solid rock, but by constructing pens of sawed timber and filling the same with boulders, a fairly substantial brace is obtained. These must be kept tightly keyed up to the roof or they lose their value as supports.

A position that should be considered of greatest importance in every mine where timbering is not employed is that of "trimmer," but this important person too often is overlooked; for the trimmer is not a producer of ore, and it takes ore to meet the pay roll. The machine men, the shovelers, the tub rustlers, the tub hookers, the mill men, the blacksmiths, all play their part in the production of ore, but the roof trimmer produces nothing. And it is with this mental picture that many operators leave the trimmer's position until the last to be filled. Sometimes it is never filled. The trimmer should be equipped with the necessary ladders for scaling the highest places in the mine; in some of the disseminated ore districts, excavations are made up to 150 feet in height, and the pillars, necessarily, are much farther apart than in the sheet-ground mines. A very



FIG. 2. PILLARS IN DISSEMINATED ZINC ORE

small boulder falling from such a height and striking a workman squarely on the head would inflict a serious wound, and would probably cause instant death. Little powder should be used in the trimming of roofs. Bars, wedges, moils or hammers, should be used and the loose rock removed without shooting.

But all the dangers of mining do not lurk in improperly mined rooms nor in badly trimmed roofs. Precaution is needed in every feature of the industry. Shafts may be improperly timbered. Clever operators may conceal such defects from the inspector; in fact, the inspector must possess a keen insight into human nature, and above all else must be "one of the boys" if he hopes to learn of the mining defects that are of real importance and which should receive immediate attention. Often a few confidential words with a spade hand, will be of untold value to the inspector who has the ability to get the confidence of the miner boys, and many has been the valuable bit of information received in an off-hand way while enjoying an evening's "gab-fest." W. S. Brown, the inspector, had spent an entire afternoon inspecting a mine in the North Webb City field. Apparently the workings were in the best of condition. Drifts seemed in good shape, shafts were properly timbered, ventilation was good and the explosives were stored far enough from the plant to prevent serious disaster in case of a blow-up. But two days later Mr. Brown closed the mine.

He hadn't found any defect during his inspection. He had left the property convinced that every letter of the law was being obeyed. That night a spade hand jokingly remarked:

"Bill, you didn't recognize your old shaft did you?"

Mr. Brown was puzzled. The spade expert then explained that one of the two shafts at the mine inspected that day was one sunk by Mr. Brown himself 20 years before. The inspector then recalled the fact that a serious cave-in had occurred in his old workings years before. Mr. Brown knew that no human power could have refilled the great gap left by the sliding ground. He knew also that conditions could not be safe where such a cavity existed. Next day he made a return visit to the plant. Half way down the shaft he gave the signal to stop. High above his head a rather surprised hoister man complied with the signal. He couldn't perceive why the inspector should wish to terminate his downward journey while yet more than 50 feet above the platform. But Mr. Brown was thoroughly posted on the course he intended to pursue. He tapped the sides of the cribbing, and at one place a hollow, far-away sound was the result. He then gave the signal to be hoisted. He hunted up the superintendent, and gave instructions to have a portion of the cribbing removed. As a result, a vast, gloomy cavern was exposed to view. The roof and walls of this cavern were treacherous. A cave-in* of the pit, although walled off by cribbing from the mine workings, would have meant a serious disaster. The mine was closed until a new shaft in virgin ground, could be sunk.

Not only is the inspector required to visit the mines of the district and see to it that their operation does not conflict with the law, but he is also required to make weekly reports to the State Bureau of Mines and Mine Inspection, of which George Bartholomaeus is secretary. These reports cover every conceivable detail of information regarding the mine on which the

report is made. Operators are required to give information concerning capital stock, number of stockholders, number of employes, volume of production, kind of ground handled and many other features.

As the use of powder is a necessity in zinc and lead mining, especially in the sheet ground and in the disseminated ore districts, knowledge of the proper methods of handling explosives is requisite. In fact, operators have shown a disposition to regard the proper care of explosives as more important than the proper handling of ground.

Enter almost any of the larger zinc and lead mines of the Joplin district and you will see, posted here and there, printed rules and regulations concerning the usages of explosives. Owing to the type of the mining, dynamite is the chief explosive employed, although black powder is used in some of the soft-ground workings.

Powder magazines should be stationed sufficiently far from mine buildings, derricks, etc., to insure little damage in case of an explosion. In addition, the magazines, to be of real value in cold weather, must be heated with steam radiators. Frozen powder can be thawed out in steam-heated magazines, and the danger attaching to some of the common methods of thawing out powder on the back of the "dog house" stove is averted. In heating the magazines, exhaust steam only should be employed, and the temperature should never be permitted to get above 95° F. A safe temperature is 80 degrees, and if this is maintained continuously results will be found satisfactory. Steam pipes must not come in contact with the explosives, for which shelves, or racks, should be provided. The farther the explosives are removed from the steam lines the better; and a rule that is observed by all powder companies and which should be observed by all mining companies is this: Never keep caps, oils, or other combustible substances in the same magazine with powder.

Only enough powder for a day's supply should be taken underground at one time but in addition to this precautionary measure, a safe place should be provided in the ground where the possibility of its being exploded by a "squib" shot, "boulder pop," or by other causes, is reduced to a minimum. An excavation of sufficient size should be made in a remote drift, or as far as possible, at least, from the scene of greatest activity, and over this opening should be placed a heavy frame door, securely locked. Keys should be carried only by the ground foreman and the powder man. Another excavation, also securely walled in, with a heavy door, should be made some distance from the powder magazine, and in this can be stored caps and fuse. No flame should be permitted to come near these magazines. Where mines are not lighted with electricity, the powder man should be careful to leave his lamp at a safe distance before taking supplies from the underground storage places.

Hard ground makes it necessary to use heavy charges in blasting. The first step is to drill a series of holes, with machine drills in hard ground, and with hand drills in medium ground, and in these holes are placed the first shots, known as the "squibs," which open larger cavities into which greater quantities of powder may be placed. Squibs should be prepared by the powder man or the ground foreman and hung at a convenient place some distance removed from the magazines. They can then be secured by the machine men as needed.

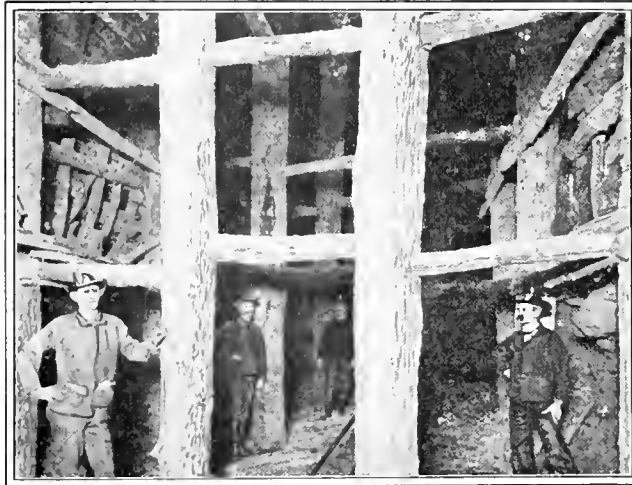

FIG. 3. TIMBERING IN SOFT GROUND ZINC MINE

*The caved-in shaft that held Cleary captive several days is a case similar to this.

Promiscuous firing of "boulder pops" is not tolerated in well-regulated mines. In heavy blasting, huge boulders often are thrown out, and these, in turn, must be broken. It has been a common practice in the past to fire these indiscriminately, at all times of the day or night. As in regular blasting, "boulder pops" should not be fired when the drifts are filled with workmen. During the noon hour, or preferably at the close of the shift, where the mine is operated only during the day, are the best times for blasting. The danger from possible flying fragments of rock is not only thus averted but more time is given for the smoke to clear away, and sanitary conditions are thus maintained at a higher standard.

Much could be said also of the right and wrong ways of loading holes. Common sense in the matter of tamping bars and tamping material should be observed, but it is not uncommon to find metal tamping bars in use and loose gravel employed as packing for the shots. Wooden tamping bars, only, should be used. Steel bars may strike sparks from the flint and the powder may be exploded. To hasten operations in order that the maximum amount of ore may be produced, too many powder and machine men have formed the habit of using steel nails in the ends of wooden tamping bars to "railroad" the sticks of dynamite through rough holes. Many premature explosions might be explained by the single steel nail in the wooden bar. If nails must be used for this purpose, copper wire will answer as an excellent substitute, and copper will not strike a spark.

In charging holes so that all air spaces are filled, a firm pressure of the tamping bar is all that is needed. Hard tamping in hard ground, even though the tamping bar be of wood, may result disastrously, as separate particles of flint may thus come together, and the powder be exploded. Soft clay or coal dust make excellent tamping materials.

"Going back on a shot" is another common method by which miners have met death or serious injury. Three-quarters of an hour should elapse before the miner approaches a missed hole, after the fuse has burned out. Squib shots have the habit, sometimes, of waiting a ridiculous length of time before going off. Powder should never be extracted from a failed hole, but a new squib should be installed after the hole has been thoroughly cleaned out.

A rule, which if followed generally, would result in much good would be to drill, whenever possible, a full round of holes a day in advance for the next day's shooting. By squibbing them at night, they are cool for the next day's shooting, and the possibility of disaster from loading a hot hole is eliminated. To load a hot hole is the height of folly.

In shaft sinking and in driving drifts from shafts, electric firers should be used. This does away with the possibility of the miner being caught by the shot.

In addition to these suggestions, a hundred and one details of minor importance, but each bearing directly on the safety of the miner, might be mentioned.

Only experienced hoister men should be employed. Several times daily they have the lives of the entire underground crew in their hands. Careful inspection of all hoisting machinery, cables, tubs, etc., should be a daily duty. Men should be hoisted and lowered at a moderate rate of speed. The desire of humorously inclined hoister men to play practical jokes on new employees has sometimes resulted in injuries. There are wiser methods of perpetrating practical jokes than by jerking a man out of a shaft at a breakneck speed.

Until recently hand rails around the tops of shafts were seldom seen. A state law says these must be installed. The mouths of the shafts must be protected so that objects cannot fall in. Ice and snow must be kept away in winter in order that the workmen, in coming up and in going down, may have substantial footing. Icicles forming along the sides of cribbing should be trimmed away daily, just as treacherous appearing boulders in the roofs of drifts should be trimmed. Loose cribbing, too, should be carefully watched, and repairs made at once. Sprinkling of dusty mines should be a regular duty. Miner's consumption, which has claimed many one-time robust workmen, is caused largely by the tiny flint particles that are breathed into the lungs. The sprinkling of drifts will eliminate, to a great extent, this menace.

Companies operating on a large scale above all others have been advised to post rules throughout their workings. Printed rules are good in small mines as well as in the large, but the operators of the latter class have been appealed to in particular. Every operator possibly will have his own ideas in what should be included in the rules and regulations, but they should be along practical lines that will help save human lives, rather than along lines frequently ob-

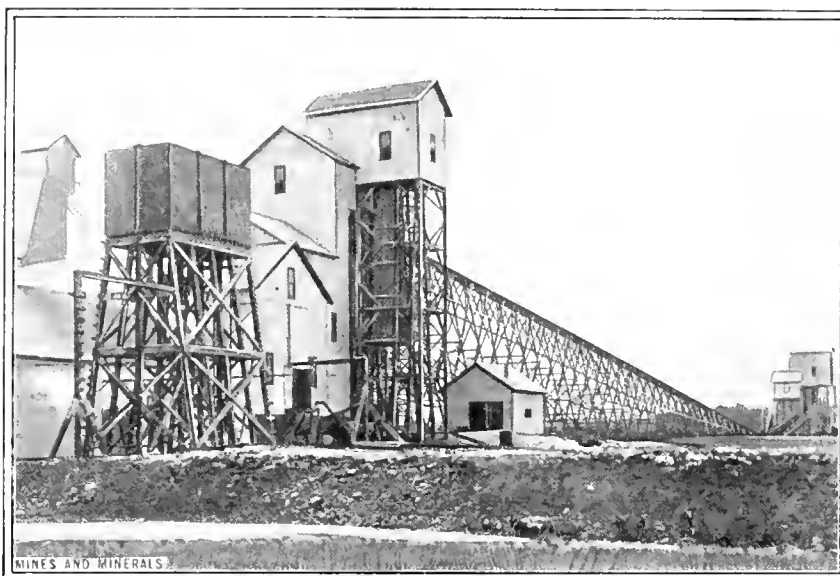

FIG. 4. ZINC MINE HOISTING ORE FROM TWO SHAFTS

served in other classes of business, where the printed advice is profusely distributed "to observe the wishes of your superiors," etc. The rules should set out in bold type the best methods of safety. Unnecessary shouting and hallooing underground, and especially upon the part of men being hoisted, should not be tolerated. Crowding about the top or bottom of the shaft at whistle time should be prohibited. Rules regarding the handling of explosives, the cutting of drifts, the trimming of roofs, rules covering every detail of the development, in fact, should be posted, and have been posted in a few of the larger producers.

The improved conditions in the Southwest Missouri district are the result of education and evolution; but while the process of education is in progress men are still being killed and crippled. Big strides have been made in the right direction. There is yet room for improvement. For much of the information incorporated the writer is indebted to W. S. Brown, State Mine Inspector, and Charles P. Wallace, former inspector.

來 來

Spaerocobaltite, cobalt carbonate $CoCO_3$, occurs in small rose red to velvety black spherical masses. Crystallizes in rhombohedra. Hardness, 4. Specific gravity, 4.02-4.15. Streak, peach blossom red. Found in Saxony, Germany, and in Cobalt, Canada.

Notes on Chilean Mills in Russia

Special Features of an Improved Mill—Method of Feeding. Capacities and Efficiencies

By H. C. Baylton

This paper was presented to the Institution of Mining and Metallurgy, London, England, and printed in Bulletin No. 75. It is reprinted at this time because of the general interest being taken in this kind of grinder by those in charge of large mills. Like the stamp mill it is a comparatively crude machine which it seems difficult to replace as a crusher. Mr. Baylton divided his paper in two sections, this being the second and dealing with the improved Chilean mill which he has adopted.

The chief features of the plant are: The mill building, the automatic belt feeder, and the improved Chilean mill.

The mill building is a framed-timber structure, the walls of which are enclosed with a double thickness of planking, interspaced with fireproof tarred building paper, the roof being covered with a double thickness of $\frac{3}{4}$ -inch boards also interspaced with the tarred paper and covered with iron.

The joints between sides and roof were carefully made tight with a sawdust filling.

It was generally held by the local authorities that this style of building would prove unsuitable for such a cold climate as Siberia, but it has proved to be entirely successful, being easily warmed with little trouble or expense by a simple steam-heating system. In fact, this type of structure is more easily warmed and kept at an even temperature in winter than the typical heavy log buildings of the country.

It was realized that this plant, to be a success, must have the mills fed by some automatic means, especially as a big output was anticipated.

The feeder of "Challenge" type, generally adopted in Chilean mills in Russia, was recognized as not being suited to the special conditions, and, at the suggestion of S. J. Speak, an overhead belt feeder, operated either by the mills themselves or by independent mechanical means, was decided upon.

Various designs were prepared and considered, and it was decided eventually to make the automatic belt feeder, illustrated in Fig. 1, at the mine workshops. This feeder has now been in continuous operation for nearly a year and has proved to be most satisfactory in its operation.

The following short description will make its action clear:

At every revolution of the mill the roller *A* is pressed upwards by means of a slide *B*, and the motion transmitted through the lever *C* to the double-armed lever *D* connected by a tie-rod *E*, causes the claw *F* to engage and push forward a friction wheel *G* keyed to the shaft *H*, to which is fixed the belt driving pulley. Thus the traveling belt is moved a certain distance forward with each revolution of the mill. Roller *A*

is brought back to its original position by the balance weight *K*, on end of the lever *D*.

The length of belt travel or feed is regulated in the first place by an adjustable screw spindle *L*, serving as a stop for the lever *C*, and by the Chilean mill itself in the following manner:

If more material be treated by the mill than is brought forward by the feeder set to a certain quantity, the runners will, when compared with their ordinary position, come to stand somewhat deeper, owing to the material in the pan becoming gradually less and less.

By the lowering of the runners, the tie-rod *M* connected to the runner sleeve will be pulled down, causing the lever *N* to turn upwards and give a more upright inclination to the slide *B*; the stroke of the roller lever *C* increases, and in conformity that of the friction-claw lever also, the mill thus getting more material until the ore layer in the pan has again reached the ordinary height.

By the same means, if the ore layer is too deep, the slide is automatically lowered and the feed reduced.

It will thus be seen that, while the feeder may be adjusted by means of a setscrew to a fixed rate of belt feed per stroke the amount of ore feed for this rate remains practically constant,

owing to the automatic regulating of the belt travel by the mill itself for variation in the amount of ore on the belt.

The only wear of consequence is in the discharge hopper (which is provided with renewable liners) and in the belt.

The cost for these renewals is estimated at .42 cent per ton.

A section of the Chilean mill with the special features of its design is shown in Fig. 2. The wear-

ing parts other than the tires and dies are brass lined.

The pan is made narrow at the grinding track, but the width rapidly increases owing to the sloping of the inside cone.

By keeping the width of the track narrow, the percentage weight of the die discarded when worn out is reduced; while by increasing the width of the pan as rapidly as possible above the grinding track, a more violent wash of the water is obtained, which holds the fine ground stuff in suspension and enables the water to carry it out of the mill rapidly, thus indirectly effecting an increase of mill capacity.

The screen opening, which is 48 inches in width, is similar to that of a stamp battery, the idea being to enable chucks of varying height to be used.

The clean-up is made through an opening 24 inches in width, closed by an iron slide, at the back of the mill.

The contents of the mill are flushed out through this opening into a special clean-up box shown in Fig. 3.

The six Chilean mills in the plant are driven by two motors, each of 50 horsepower. Three of the mills are run at 14 and the remainder at 16 revolutions per minute.

The capacity of the mills at present is limited to about 39 tons each, any output beyond this per mill causing excessive overload.

The information given here has been obtained from a series

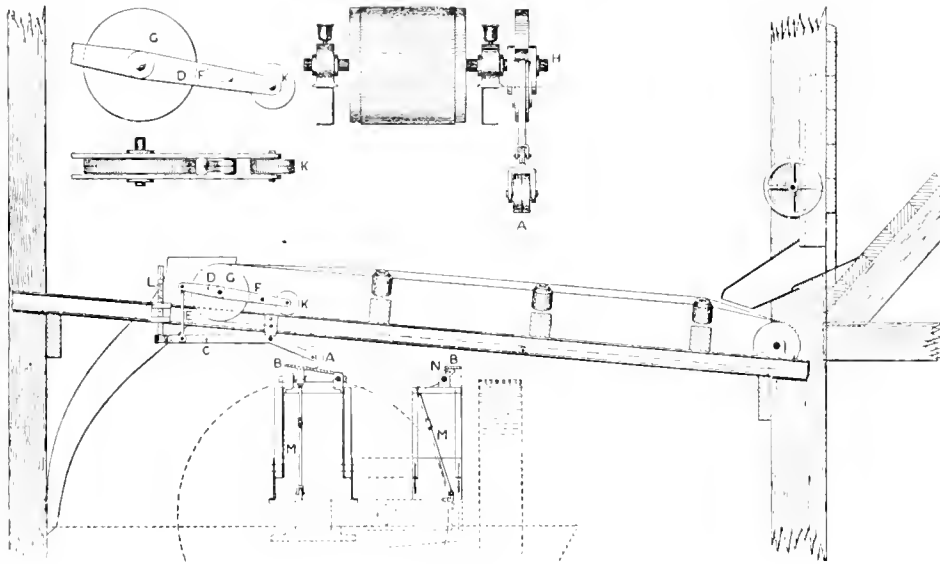

FIG. 1

...s, made under ordinary working conditions at odd times... favorable opportunity offered, a full and complete record... varying conditions being beyond the author's means... all trial runs, however, care was taken in measuring quantities and speeds as well as in taking pulp samples. The capacity of the mills and power required with different belt-feeds was checked, not only during the trials, but over long periods.

DIMENSIONS, ETC., OF MILL

Diameter of fan.....	10 ft. 3 in.
Distance between center of runners.....	8 ft. 6 in.
Revolutions of mill per minute.....	14 and 16
Mean runner travel per minute.....	340 ft. and 427 ft.
Diameter of runner.....	72 in.
Width of face of runner.....	12 in.
Weight of runners (each).....	10,000 lb.
Weight of tire alone.....	6,040 lb.
Weight of dies (set).....	4,880 lb.
Size of discharge opening.....	44 in. X 8 in.
Gross weight of mill.....	23 tons

One series of tests was omitted, which the writer would have liked to make; namely, with regard to the effect of size of feed on capacity; while other tests which might have afforded useful information have not yet been practicable.

The maximum desirable size of ore feed, calculated by Philip Argall's* formula for rolls, is a 3.4-inch cube, and the average ore feed of these mills is:

+ 3 inches square.....	Per Cent.	5.7
+ 1 1/2 inches square.....	42.5	
+ 1 inch square.....	27.6	
+ 1/2 inch square.....	24.2	
	100.0	

The same author recommends reduction in the ratio of 4 : 1 for greatest efficiency with rolls,† but this would not apply equally to Chilean mills, although the increase of the mill might be obtained with a finer ore feed.

The results obtained with the mills running at 14 revolutions per minute are given in Table 1:

TABLE 1

Belt Feed Per Revolution of Mill Inches	Output Per 24 Working Hours Tons	Power Required Per Mill Horsepower	Increase in Belt Feed Per Cent.	Increase in Output Per Cent.	Increase in Power Per Cent.	Decrease in Output to Increase in Belt Feed Per Cent.	Increase of Power With Decrease of Output Per Cent.	Ore Crushed Per Horsepower Per Day, Tons
2.50	36	14.70						2.45
3.00	39	16.27	10	8.33	10.7	1.67	2.37	2.40
3.60	42	17.32	20	16.66	17.8	3.34	1.14	2.42
3.60	51	23.62	44	41.66	60.7	2.34	19.04	2.16

The second half of the Chilean mills in the plant has only quite recently been altered to run at 16 revolutions per minute, and, as the runner tires are already partly worn, results as to capacity with the different belt feeds at this speed are not comparable with those in Table 1, or sufficiently reliable for publication. Trials, however, indicate that the increase in capacity is at least proportional to the 14 per cent. increase in speed, and that the decrease in crushing efficiency with the heaviest belt feeds is less. The load on the motor is also more even. The author is of the opinion that these mills

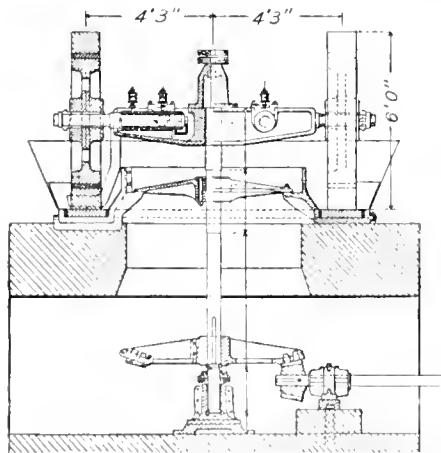

FIG. 2

with the heaviest belt feeds is less. The load on the motor is also more even. The author is of the opinion that these mills

*Transactions I. M. M., 1901-1902, page 254.
†Ibid., page 253, et seq.

could be run at 20 revolutions per minute with advantage, but to do so would necessitate replacing the collar bearings of the runner axles with ball bearings.

It might be inferred, from a study of the above table, that the horsepower required with a belt feed of 3 inches is probably low. This could not be confirmed, but that for the other feeds has been checked on various occasions.

It is interesting to note that an increase in the depth of ore on the dies does not act as a cushion to the same extent as

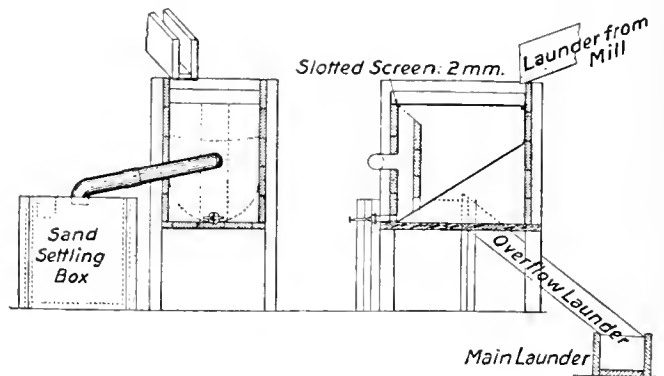

FIG. 3

in stamp mills, for it is found that, with an increase in the feed of 44 per cent., the apparent decrease in output is only 2.34 per cent.

Mill Product.—The averages of a number of screen tests made are given in Table 2:

TABLE 2

1 Millimeter Screen	Belt Feed, 2 1/2 Inches Rev. of Mill, 14. Capacity With Feed, 39 Tons Water Ratio, 4.8 : 1. Height of Discharge, 10 In. Screen, 1/2 mm. Slotted (.0196 Inch)	Belt Feed, 2 1/2 Inches Rev. of Mill, 14. Capacity With Feed, 39 Tons. Water Ratio, 5 : 1. Height of Discharge, 10 In. Screen, 1 mm. Slotted (.039 Inch)	Belt Feed, 2 1/2 Inches Rev. of Mill, 16. Capacity With Feed, 41 Tons. Water Ratio, 5.3 : 1. Height of Discharge, 10 In. Screen, 1 1/2 mm. Slotted (.059 Inch)
+ 30 (.016 inch).....	.17	.56	.70
+ 60 (.0083 inch).....	5.20	8.10	8.72
+ 100 (.005 inch).....	16.37	20.23	21.20
- 100	78.26	71.11	69.38

While the product from these mills is fine and of very even grade, the percentage of -100 product is much less than in the majority of the Chilean mills used in Russia.

A comparison of a great number of results with 1 millimeter screens shows the greatest fluctuation of +60 product, and the -60+100 to be the most constant.

The factors which govern the height of discharge best suited for any mill and the water-to-ore ratio are: (1) speed of mill; (2) length of screen opening and mesh of screen used.

The rapidity with which the pulp is discharged after being ground to the requisite fineness indirectly influences the efficiency or capacity of the mill; and this depends on obtaining the most efficient water action within the pan.

If the height of discharge is too great, or too much water is used, the tendency will be for the particles to rise in strata according to their specific gravity, and the percentage of +60 in the discharged product will be low. On the other hand, if the height of discharge is too low, or too little water is used, the ore layer becomes partly uncovered, and therefore, at each revolution of the mill, particles sufficiently crushed are not all offered facility to rise in the water current and do not receive equal opportunity to discharge.

The +60 product is the most sensitive to any small variations in either of the above respects and, as already remarked, shows greatest fluctuation.

In the mills running at 14 revolutions per minute, it has been found from experience, confirmed by sizing tests, that a height of discharge of 9 inches to 10 inches, and a water ratio from 4.5 : 1 to 5.5 : 1, with 1 millimeter screens, gives, all things considered, the best results.

The water is regulated to form a thin layer about 1 inch to 1½ inches in depth immediately behind the runner, and advances in front in a high wave.

To obtain this ideal action with ½ millimeter or 1½ millimeter screens, keeping height of discharge constant, less water is required with the former and more with the latter.

The most suitable height of discharge will vary with different speeds, and can be lower with a slower running mill.

The screen opening in these mills could be longer with advantage, for, to take an instance, the limit of capacity without undue loss in efficiency, using a screen with ½ millimeter opening, is about 39 tons; and it is also, if anything, better to use a screen with 1½ millimeter opening when running the mills at their greatest capacity, although it is to be noted that the latter screen does not influence the size of the discharged pulp.

The product from the mills at 16 revolutions is slightly coarser than at 14 revolutions. The mechanical efficiency of mill works out as follows for the product with ½ millimeter and 1 millimeter screens:

Mill feed	Per Cent.
+ 3 inches.....	5.7
+ 1½ inches.....	42.5
+ ¾ inch.....	27.6
- ¼ inch.....	24.2
1.172 inches.....	100.0

That is, 100 per cent. mean, based on common law of average.

TABLE 3

1 mm. Screen	Aperture	E. U. Factor	Sizing Tests, 1 mm. Screen Per Cent.	Pulp E. U.	Sizing Test, 1 mm. Screen Per Cent.	Pulp E. U.
30	.0166	17.8	56	.0910	.17	.03
60	.0083	20.8	8.10	1.6800	5.20	1.08
100	.0050	23.0	20.23	4.6500	16.37	3.76
-100	slimes	27.0	71.11	19.2000	78.26	21.13
			100.00	25.6300	100.00	26.00
E. U. of mill feed..... =				-.6900		-.69
Work done by mill per unit.....				26.3200		26.69

Total work done in 24 working hours:

39 × 26.32 = 1026.48 39 × 26.69 = 1040.91

Efficiency: $\frac{1026.48}{16.27} = 63.09$ per cent. $\frac{1040.91}{16.27} = 63.97$ per cent.

Two copper amalgamation plates, each 4 feet in width by 10 feet in length, are used for each mill. The feeding of mercury to the mills is similar to ordinary practice and for the reasons that the plates are run hard and kept under locked covers. The important difference in procedure is that the clean-up is made through the opening behind, and the plates are therefore not interfered with except for dressing once a day and removal of amalgam.

TABLE 4

	No. 2 Mill	New Plant
Time of clean-up for each mill.....	20 min.	15 min.
Gold recovered from amalgamation.....	38.74%	61.35%
Mercury losses per ton crushed.....	.69 oz.	.36 oz.
Amalgam recovered from mills.....	81%	73.9%
Amalgam recovered, plates.....	18%	24.6%
Amalgam recovered, sundry sources.....	1%	1.5%

That the small alterations and changes in the general lay-out of the mill, and in the clean-up and amalgamation practice, are an improvement on the usual practice may be

inferred from the comparison with No. 2 mill, section 1, which was treating exactly the same ore as shown in Table 4.

The higher percentage of amalgam recovered from the plates in the new plant is primarily due to the more violent water action within the pans.

Reliable figures for wear of tires and dies are not yet available for the new mills, but careful measurements have been made and it is estimated that the net wear of tires is from .62 pound to .65 pound, and of dies .28 pound per ton crushed.

The weight discarded when these parts are worn out will probably be from 9 to 10 per cent. in the case of tires, and 35 per cent. in that of dies.

The wrought-iron outside liners last about seven months.

The life of slotted screens is about 1,200 tons of ore crushed, each screen costing \$3.56.

The author would summarize his observations from the running of this improved plant as follows:

The mill is an extremely simple crushing machine, requiring no skilled supervision and very little attention, and is almost "fool-proof."

Temporary failure of the feeder has no other effects than to reduce the capacity of and the power taken by the mill, which is in marked contrast to the effect on a stamp mill if the battery is not immediately hung up.

The mill produces a product of uniform fine even grade, and its mechanical efficiency as compared with stamps, producing in one operation a similar fine-ground product, is vastly superior. The most suitable water-to-ore ratio by weight with these mills is low and compares favorably with that required with stamps.

If the amalgamation plates could be in a separate room and run soft, the running time lost, due to "clean-ups," dressing plates, etc., could be greatly reduced, while it would be possible to run three days or more without making a clean-up of the mill itself. The most suitable capacity at 14 revolutions per minute may be taken as 42 tons per 24 working hours. At the higher capacity of 51 tons the mill is overtaxed.

A throw of about 3 inches for the belt feeder appears to be the most suitable. To put through a higher tonnage with a mill speed of 14 revolutions, it would be advisable to provide a feeder with a wider belt. The mill at 16 revolutions could be run for a capacity of 50 tons, and at 20 revolutions for from 60 to 65 tons.

If this mill were converted into a three runner, which could be done at little expense or trouble, the capacity would be increased 50 per cent. for each speed. The mill, however, as it stands, compares favorably with stamps on a tonnage basis in respect of space occupied, and in initial cost and cost of erection the advantage is also with the former.

Finally, the author is of the opinion that, if the same amount of thought and attention were devoted to the development of the capacity of this type of Chilean mill as has been devoted to the heavy stamp tube mill combination in South Africa, it would prove a serious rival and give a product nearer to the ideal aimed at on that gold field.

采 采

Radium Minerals in Australia

A recent discovery of radium in the northern part of South Australia, near Mount Poynter, according to Vice-Consul Baker, of Sydney, is said to be developing satisfactorily, rich ore being raised from workings already started, this ore being described as uranophane, a hydrous silicate of uranium and calcium. Uranophane is regarded as a product of pitch blende, and when pure contains 67 per cent. of uranium trioxide. Another locality where radium-bearing ores have been discovered is the Wodgina region in the Pilbarra gold-field district, in Western Australia. A new ore of uranium has been found here. It is termed pilbarite, and is of an ochreous yellow to lemon-yellow appearance, very much like carnotite. Pilbarite contains 27 per cent. of uranium, with some oxide of lead and other substances.

Relation of Forestry to Mining

The Necessity of Preventing the Reckless Exploitation of Timber Lands in Mining Regions

By J. F. Lawson*

Forest officials in reporting the facts in regard to mining claims, are doing precisely the work they are paid to do; but they are not merely protecting the people in their right to maintain the forest; they are also protecting the people in the maintenance of the policy sought to be carried out by the mining laws. If any essential requirements of the law be dispensed with, the lands will be appropriated in a way not contemplated by Congress, and in a way seriously to hamper the mineral development of the country.

If patents are to be secured to thousands of acres of valuable timber land by an evasion of the mining laws, and if timber is stripped off for the profit of the perpetrator of such fraud, the timber will not be at hand when the honest miner wants to use it to develop a mine. The title of the land having passed, the prospector will no longer have free access to it, nor the expectation of owning it if he should find mineral thereon. The timber land is not the only land which would pass out of the reach of the prospector if the laws are to be evaded. The law does not contemplate, when a man makes a strike, that he or any one else should obtain, besides his first claim, all the ground he can stake out around about, unless he makes a new discovery and does the required work on each claim.

In the early days of the mining camps this regulation was enforced by the presence of hundreds of miners who would "jump" a claim on which the holder was delinquent in assessment work. In those days there was no complaint of the law working a hardship. And the United States has the right to enforce its regulations in all cases, even though no one else for the time being is wanting the land. If the provisions of the law be not enforced, these vast bodies of mineral land will be taken up by speculators who will hold them until somebody on neighboring property does the work to make the holding valuable. The great bulk of the public domain would soon pass into the hands of men who would hold it and fence it as grazing lands, to the detriment of the small cattleman as well as to the detriment of the whole people. There would soon be little left of the public mineral lands which the prospector would be free to locate for the valuable mineral he could find.

The speculator is a far-seeing man who does not take chances with his money. He looks ahead for returns at the expense of others. The mineral resources of the country will never be developed by speculators. The prospector is a different sort of person; he seeks the risks which the speculator scrupulously avoids. All he has and all he can borrow he will spend digging into the earth. He is the person for whose benefit the mining laws are framed. Give him access to the lands and he will develop the mineral resources. The United States, by holding the title to the mineral lands sacredly in trust until such a man comes who is willing to do his assessment work, until he actually makes a discovery, is doing more to promote the mineral development of the country than all the stock jobbers and advertising promoters that ever lived.

It may be granted that the mining broker cannot well float stock to secure money to make a discovery and to develop a mine until he has patented his claim; but the laws were not formulated for the benefit of that kind of schemers. The patent is a certificate of the Government that a valuable discovery has been made; and promoters have no right to ask the Government to indorse and recommend their mines to prospective investors unless they have in fact made a valuable discovery. The mining laws are designed to enable men to make mines and not to promote the sale of them.

*Law Office of Forest Service, Denver, Colo.

The genuine miner and the honorable mining engineer will be willing to make their money out of the earth and will not insist upon the right to take it from the tenderfoot. There is no reason in public policy why large unexplored areas should be given to fraudulent promoters in order to enable them to fleece unwary investors. You have seen or will see entries of large tracts of land, chosen with little regard for their mining possibilities, that have never been developed, or, if worked at all, have been worked with so little regard to the simplest rules of mining that the money invested has been absolutely wasted. It has been of no value even in proving the character of the ground upon which it was spent. Every dollar so wasted in unprofitable mining is lost to some legitimate mining enterprise. It is not merely sunk in a hole in the ground; its loser has become a walking signboard to advertise the uncertainty of mining and the unreliability of mining engineers. A fraud upon the United States and upon the Forest Service is equally a fraud upon the mining fraternity. No class of men has greater interest than they in an honest and faithful enforcement of those laws of the United States which were designed to encourage the development of the mineral resources of the country.

The Forest Service is but an entering wedge for the broader and truer policy of conservation. In parceling out his reality Uncle Sam had certain policies in view; among them, especially, that of promoting the greatest good of the greatest number of its citizens. He meant to be impartial to his nephews. We have now a machinery of law more or less efficient to prevent the individual from being robbed of the fruits of his labors. There will presently be found some more effective way to prevent any one man from seizing more than his share of the natural resources which should be regarded as the heritage of all.

In working out the policy for the conservation of resources, the state will exercise a constantly increasing supervision to see that these human forces are better conserved than they have been in the past.

They are not all saints in those amalgamated orders of high-graders and dynamiters, but such as they are they average as good as we average anywhere. Thieves are thieves whether in overalls or automobile coats. The anarchist in rags is as respectable as the magnate who runs a railroad train through the constitution and the laws. The same moral obliquity which permits one man to fill his pockets with picture rocks has permitted another to steal a mine. Some steal railroads; others can only steal rides upon them. There is a growing belief that if some way were found to stop the great piracy it would be easier to stop the petty pilfering. It is easy to see in some communities the balance disturbed between uplifting forces and degrading influences. Cannot the law reach out and restore the balance or even restrain the downward tendency?

You in the West are familiar with the mining camps; you know their sturdy, reckless life; you know also the contagion of the surroundings where men see millions staked and lost and other millions won without a risk. You think it absurd that the state must look out for men so well able to look out for themselves. But you forget the missed shot or the rock fall in the lonely slope. You do not see these men, as a result of their hardships, broken in fortune, health, and spirits, with their families a charge upon the communities in which they have sought refuge.

Once the West was far off and thinly peopled; wages were high; but there is no more distance. The swarming life of Europe and Asia is now at hand willing to earn a bare sustenance, whether at Scranton or Coeur d'Alene, at Spring Valley or Ketchikan. The scum of the earth and the cream of the earth's greatest race are here working side by side to make the dividends which enrich stockholders and make the prosperity which upbuilds cities and states.

I have been bred in the law and am disposed to see things done in an orderly way. I must yet confess to an impatience with that manner of statesmanship which can do nothing because

unable to agree whether it should be done by the general government, by the state, or by the cities, or whether it should be left to be done by the corporations. The lawyers say that ours is a government of limited powers, and it has its peculiarities. But the constitution has always been equal to every task found necessary to impose upon the national government. When the people of the United States find it necessary, in the preservation of their own lives and the promotion of their own welfare, to pass any laws regarding the mining industry they will find in that document unexpected powers. By Article I, Section 8, the Congress of the United States was given power to lay and collect taxes, duties, imposts, and excises; to pay the debts and provide for the common defenses and general welfare of the United States. When there shall be chosen to that Congress men who are interested in doing the work, rather than in finding excuses for not doing it, it will no longer be necessary to cast about in the power to regulate commerce or in any other obscure clauses to find ample authority.

I recently went through one of our western forests looted by the tie choppers of a great railroad. It was as though a butcher had gone through a herd, stripped the loin steaks from every beef and left the animals to die. From a dozen townships these magnificent lodgepole pines, running nearly 100 feet in height, without a limb, had been felled that two ties might be taken from the butt. Props enough to have timbered all the mines of Wyoming were lying there to rot or to become tinder by which the forest should be burned when a careless smoker or a stray bolt of lightning passed that way. Certain it is to come as that the mine explosion will follow the accumulation of fire damp, yet for the present the forest lies a colossal ruin. The lodgepole is as gregarious in its habits as man. Robbed of their society and separated from its fellows, it goes down before the tempest. As I looked there upon the dead and dying trees, windfall and waste lying in inextricable and impassable confusion—a strange, fantastic comparison came to me. Suppose, I thought, the lives of men were as delicate and their bodies as indestructible as these trees and that it were not the fashion to bury our dead out of sight. The earth would presently be encumbered with such evidence of disregard for human life and limb, when set over against the human greed for gold, that the entire remaining population would arise en masse and annihilate the unmasked doctors and the convicted captains of industry. The *corpus delicti* of a great crime has been buried. But the crime remains and some day the murder will out.

采 采

Himalaya Tourmaline Mine

By John Cowan

The Himalaya tourmaline mine, at Mesa Grande, is owned by the Himalaya Mining Co., of New York. The company's agent in charge of the property is J. Goodman Braye, Jr., who was born in Australia, of African parentage, and who came to America when only a lad to make his fortune. He is now in sole charge of the greatest tourmaline mine in the world, so that his career furnishes proof that the accident of race or color is no bar to achievement in this country.

Externally the Himalaya tourmaline mine is as commonplace and uninviting as any coal mine. From 1898 until 1905 operations were conducted by surface or bench digging. Then the overburden of earth became so great that its removal was unduly expensive, and in the rainy season trouble was experienced with the caving in of the sides, so a tunnel was driven for a distance of several hundred feet, following the gem-bearing vein the whole way. This vein varies from 18 inches to nearly 4 feet in thickness. The tourmaline occurs in irregular pockets, mingled with talc, hydrous mica, and an extraordinary variety of other minerals, some of which possess some value, while others are worthless. Among these are lepidolite, quartz

crystals, orthoclase, spodumene, muscovite, beryl, hornblende, spessartite and essonite garnet.

The entire mass of material in the pocket is removed, taken outside in mine cars, and conveyed to the washing plant, which is remarkable only for its simplicity. A hose is first turned upon the material, which sufficiently clears the large crystals and other minerals for their identification. Many of the small crystals are covered with tightly adherent talc and clay; so that the mass of small, broken mineral is placed in a suspended barrel, to which a hose is attached, permitting a steady stream of water to be poured in. An outlet in the end of the barrel permits the escape of the water. The barrel is shaken vigorously for as long as may be necessary for the removal of the clay and talc, and the material is then emptied upon trays. The tourmaline crystals and other gem materials worth saving are then picked out by hand.

The tourmaline crystals are sorted with respect to size and quality, varying from small, pencil-like crystals, not more than an eighth of an inch in diameter, up to crystals 2 or 3 inches in diameter. In these crystals almost all the colors of the rainbow may be found. Tourmaline is known by various names, depending upon the color. The red or pink transparent variety is called rubellite; the violet-red, siberite; the blue or bluish-black, indicolite; Berlin blue, Brazilian sapphire; green, Brazilian



FIG. 1. SORTING TOURMALINES AT MESA GRANDE

emerald; yellow or amber is known as Ceylonese peridot; colorless tourmaline as achroite; black, with resinous fracture, as apbrizite; and brown or greenish-black as dravite. All these varieties are found at Mesa Grande.

It is difficult to make a general statement of the value of tourmaline as a gem material, this depending upon its freedom from checks and flaws, its transparency, color, luster, and hardness. The great mass of tourmaline as it comes from the mine is worth but a few cents a carat, on account of checks, cracks, bubbles or lack of transparency, or the colors being too pale. Whatever value such material has as a jeweler's material arises, in the main, from the cutting. But flawless tourmaline, of exceptional hardness, suitable for cutting in the same manner as diamonds is worth from \$5 to \$20 per carat. Material has been taken from the Himalaya mine that no one but an expert could tell from ruby; and specimens of green tourmaline are sometimes found that almost rival the emerald in appearance. So while some crystals are worth no more than quartz crystals or garnet, others of exceptional hardness and coloring nearly rival the diamond in value. The range of hardness is great, some specimens being 7, some 7.5 and some 8, in the scale in which the hardness of the diamond is 10.

China offers a ready market for all the pink tourmaline not readily absorbed by the American and European demand. Late in June the sale to Chinese dealers of many thousands of

part of this material from the Mesa Grande, was reported. Each year (in common with most other highly colored gems) tourmaline is coming more and more into favor, and is enhancing in price. However, in this country it does not yet enjoy the popularity it merits, as a distinctively American gem. One advantage it possesses is in the fact that it cannot be successfully imitated, owing to certain peculiar optical properties. Plates cut from transparent crystals, parallel to their length, are much used in experiments in optics, on account of their remarkable polarizing action on light.

Tourmaline is found in Burmah, India, Siberia, Germany, Brazil, Maine, Massachusetts, Connecticut, New York, and California; but in most sections its occurrence is haphazard and uncertain, not justifying systematic mining operations. Nowhere are gems found so abundantly or of such remarkable size, beauty, richness and variety of coloring as at Mesa Grande. Only the Himalaya and San Diego mines are in operation, but the Esmeralda mine, a mile and a half distant, has yielded some fine gems and may give a good account of itself hereafter. Numerous other prospects have been located in various parts of San Diego and Riverside counties, but their value is problematical.



General Ore Mining Notes

High Financiering in Mine Claim Shares.—Occasional publicity such as the following received from August Wolf, of Spokane, Wash., may have a salutary effect in time. L. E. Collier, receiver of the Naomi Gold Mining Co., says, in a report filed in the Spokane County Superior Court, that 65 cents of every dollar received from the sale of stock was paid as commissions to L. L. Ratliff, sales manager, and there is no trace of the remaining 35 per cent. The company, which is capitalized at \$1,500,000, exchanged its capital stock with W. D. Irwin for mining claims in Oregon, says the receiver. Afterward Irwin transferred back 500,000 shares of the stock, which was held as treasury stock, and it was this stock that the company turned over to L. L. Ratliff as sales manager. The company did not file its articles of incorporation in Oregon, where the property is located. The debts amount to \$4,000, including assessment work.

Spokane Interstate Fair.—L. K. Armstrong, superintendent of the mining department of the Spokane Interstate Fair, is making preparations for a convention of mining men from all parts of Washington, Oregon, Idaho, Montana, and the province of British Columbia at the fair in Spokane the week of October 2. The Spokane Mining Men's Club and the Spokane Chamber of Commerce will cooperate with Mr. Armstrong in making the meeting the most important of its kind in this part of the country.

Republic Gold Mining Camp.—According to Charles H. Goodsell, deputy United States Mineral Surveyor, 15 mines in the Republic camp have ore ranging from \$40 to \$50 per ton. The principal value, however, is in the low-grade ore, of which there are millions of tons suitable for milling. In the Lone Pine and Surprise mines, for hundreds of feet along the workings below the Jim Clark tunnel or Bonanza shoot, there are large quantities of ore running from \$9 to \$16 a ton. This will make a large percentage of profit when handled and milled on the ground. Instead of shipping this ore, the company is forwarding a grade running from \$35 to \$45 a ton, which is found in numerous ore shoots and is so clean that it can be loaded on to the cars without sorting. The adit in the Knob Hill struck ore 100 feet from the portal at 125 feet below the surface. This vein was followed for 200 feet and a raise of 75 feet showed \$60 ore. The mine now has ore blocked out that will net \$100,000. It is shipping a carload a day, and the last 75 cars have averaged \$43 a ton net. The operating, shipping, and smelting expenses are about \$10.

Kendall Mining Co., operating the Kendall gold mine, at Kendall, Mont., paid its 81st dividend, bringing the total to \$2,005,000 paid to August 24. It was the usual monthly disbursement of 2 cents a share, or \$20,000, the company's capital being \$500,000. The dividends paid so far this year total \$80,000. The company is a Spokane corporation, controlled since its inception by Messrs. Finch and Campbell.

Stewart Mining Co. says in its first semiannual report that mine operations in the Coeur d'Alenes during the first 6 months of 1911 resulted in concentrator returns of \$299,435.40, ore returns of \$21,373.98, and miscellaneous revenues of \$300.23, a total of \$321,309.61. The total expenses of the mine and company were \$180,513.51, leaving a profit for the 6 months of \$140,796.10.

Cleveland Mine, Idaho.—Federal Mining and Smelting Co. has taken a bond for \$400,000 on the Cleveland mine, near Mace, Idaho, adjoining the Standard-Mammoth group, which the corporation acquired from the late Thomas Greenough and Peter Larson for \$3,000,000 about 7 years ago. The Cleveland is owned by Mrs. James Leonard, of Spokane, William R. Leonard, of Denver, and Richard Wilson and Walter McKay, of Portland. It is understood that the Standard-Mammoth ore bodies extend into the Cleveland property, to the line of which the former has been worked. Charles Sweeney, former president and F. H. Brownell, president of the Federal; started negotiations for the option at a conference in Seattle several months ago. Clayton Miller, of Spokane, general manager of the Federal properties, confirmed the report of option, but declined at this time to give any details. The company, which is one of the largest producers in the Coeur d'Alene district, has been paying about \$210,000 quarterly in dividends for some time.

Zinc Ore in Idaho.—Herbert Salinger, of Salt Lake, Utah, representing the Paragon Consolidated Co., of Paragon, Idaho, has closed a contract by which a market is provided for the zinc concentrate and lead-silver concentrate produced by the Blackhorse concentrating plant. The lead product will be marketed in Salt Lake, while the zinc product will be forwarded to the Kansas smelters. The Blackhorse mill is operated every other month and the management produces up to 300 tons of zinc concentrate on the 30-day runs, and half of this tonnage of lead concentrate. Plans are now on foot to revamp the mill so that it will produce 15 cars of concentrate a month.

Platinum and Tin.—Those interested in the rarer common metals will learn with regret of the closing of the platinum mine at Rambler, Wyo., and of the mine and smelter of the El Paso Tin Mining and Smelting Co., El Paso, Tex. These operations, by reason of their limited tonnage, were unimportant factors in our production of either of these metals, but they enjoyed the unique distinction of being the only platinum mine and only tin smelter in the United States, and thus, as a matter of national pride, their suspension is regrettable. With the closing of the Gap (Pa.) mine many years ago the United States ceased to figure as a producer of nickel; the production of platinum, except from black sands, is cut off by the closing of the Rambler mine; our only tin smelter is closed, although some concentrates may still be expected from South Dakota and the Carolinas, and the output of mercury has long been on the decline. It is odd that these four metals, platinum, tin, nickel, and mercury, while found at widely separated points in the United States, are, with the exception of mercury, nowhere met in commercial quantities. Whether they do not exist commercially or whether systematic and diligent search will discover them is problematical and rather doubtful. In the matter of searching the United States Geological Survey might be of material assistance in indicating where to prospect and where not.

Cripple Creek Ore Shipments.—The output of Cripple Creek for August was the largest for any 31-day period this year, amounting to 79,067 tons of ore with a value of \$1,367,115, or

2,446 tons, valued at \$36,592 more than in July. The shipments of low-grade ore were exceptionally large.

Golden Smelter, Colo.—Officials of the North American Co. report that the company's smelter at Golden is now handling more ore than it has at any time since the plant was acquired by the present owner. The ore comes principally from Clear Creek, Gilpin, and Boulder counties, much of it from mines that the company owns or holds under lease and operates on company account. The policy of the management in getting hold of more property, and thus making certain of a continuous supply of ore, is maintained. Recent acquisitions are Decatur, Helmer, National, and the Mammoth mines in Gilpin County. It is also getting a supply of custom ore that shows that the operation of the plant is stimulating mining activity in the sulphide belt of Northern Colorado.

Idaho Springs Ore Shipments.—Shipments of smelting ore and concentrates from Idaho Springs so far during 1911 show an increase over the shipments of a year ago. Three mills are in operation—the Jackson, the Hudson, and the Newton. H. B. Clifford, of New York, who holds leases on a number of mines near Idaho Springs, reports that Thos. A. Edison has agreed to make experiments with the ore of the district, and to try to work out a more economical and profitable method of treatment.

Testing Old Placers.—H. J. Reiling, manager and one of the principal stockholders of the French Gulch Gold Dredging Co., is making tests on the gravel of the Peabody and Fortune placers in the Tarryall district of Summit County. The ground contains 4,000,000 cubic yards of gravel that is said to average 25 cents a yard. Mr. Reiling and his associates have deposited \$22,500 in a bank to hold a 90-days' option. The French Gulch dredge is now paying.

Camp Columbine is among the latest aspirants to fame in the mining districts of Colorado. It is situated on the southern side of Mount Rosely, 10 miles south of Idaho Springs, and 60 miles west of Denver. H. G. Groth, who has been working a prospect on the mountain for 7 years, reports the discovery at a depth of 45 feet of ore that runs \$8,500 a ton. The assay that gave this high value was made on a picked sample, but Groth says that he has ore in large bodies that runs well in both gold and silver.

Potash Deposit in Nevada.—It has been known for some years that potash deposits have existed in Nevada and Utah, but no attempt was made to utilize them owing to the market for such products being in the eastern United States, where the German potash held control. Reports from Goldfield, Nev., state that a potash deposit will soon be opened in Railroad Valley, in Nye County, about 75 miles from Goldfield. The surface deposit shows from 6 to 7 per cent. potash, and it is believed that it will increase in purity with depth.

Camp Terrill, Nevada's latest mining strike, is causing the usual commotion. The first find carried \$1,200 per ton; since then a second find is reported carrying 50 cents to the pound in silver. A. G. Price, of Fallon, is quoted as saying that "there are 11 ledges traversing the original locations, all of which have been opened sufficiently to show that they carry ore." From a shaft 107 feet deep on the original claim an abundance of water is being pumped by gasoline power, and the locators of the camp have a fine garden which they irrigate with this water.—*Fallon Eagle.*

Central, Nev., Placers.—Two miners cleaned up \$450 by washing 5 days at Central. On the Fulkerson claim, to the east of Central, there are 400 feet of underground workings on pay gravel from 1½ feet to 3 feet thick that yields \$16 per yard. "Dry Wash" Wilson is still employing over 25 men in his placer workings, the plant being kept busy day and night washing the auriferous gravel. No figures are given out for publication.

Quicksilver Mining.—According to H. D. McCaskey, of the United States Geological Survey, there are two producing quicksilver mines in Nevada. From 35 tons of this ore 5,250 pounds

of quicksilver was produced. In California there are 15 producing mines whose ore averaged .5 per cent. per ton, or 10 pounds. From 115,305 short tons of ore 15,825 flasks weighing 75 pounds each was obtained. The average price in 1910 at San Francisco was \$44.51 per flask; at New York, \$47.06. The two producing quicksilver mines in Texas produced 8,221 tons of ore, yielding an average of 1.5 per cent. metal, or 30 3 pounds per ton. The entire output in the United States was 123,562 short tons, which averaged .6 per cent. metal.

Comstock Lode's Mexican Mine.—This mine broke its record for weekly ore extraction recently, there being 745 mine cars hoisted with ore that totaled \$34,417.45. The previous weekly record was about \$26,000 in ore. The ore came from the 2,500-foot level, and 168 cars averaged \$113 per ton, being the richest ore and largest tonnage from any one place in this mine. Considerable good ore has been found recently in various places on the Comstock lode.

Anaconda Mine, Mont.—The Anaconda management is so well satisfied with the results being obtained from the hoisting of ore by compressed air, that it has determined to enlarge the compressor plant to a sufficient capacity to provide power for all the company's mines. It is expected that the Diamond mine will be started up this week under the new system.

The station at the 2,800-foot level of the North Butte has been completed and cross-cutting will begin immediately to get between the fault planes encountered on the 2,000-foot level and which later developments have shown to diverge widely with depth.

Park City Mines Consolidation.—All the legal details toward consolidating the Daly Mining Co. and the Ontario Silver Mining Co., at Park City, Utah, have been arranged, so that these two properties can be merged. This would bring together two of the famous old producers of the country, which have many millions in dividends to their credit. It is proposed to create a new corporation to take over both the former incorporations. This corporation is to be capitalized at \$1,500,000, divided into 300,000 shares of \$5 par value. The capital stock is to be allotted so that 75,000 shares will go to the Daly for its property and 150,000 shares to the Ontario, with 75,000 shares in the treasury for development uses.

Changes in Colorado School of Mines.—A number of important changes are noted in the faculty of the Colorado School of Mines, Golden, which recently opened for the fall term. George W. Schneider and Carl A. Allen, both graduates of the institution, succeed Arthur J. Hoskin and Alwyn C. Smith as professor and assistant professor of mining. The place of Frank H. Cronin, who has returned to the East, has been filled by the promotion of Assistant Professor R. B. Otis. William G. Haldane, G. Montague Butler, and Ransom S. Hawley have been advanced from assistant to associate professorships of metallurgy, geology, and mechanical engineering. Mr. Siegfried Fischer is now instructor in place of fellow in physics. Mr. F. S. Titsworth, E. M., a graduate of the school, is lecturer on mining law, vice Joseph S. Jaffa, resigned. The faculty has been greatly strengthened by the appointment of Dr. Regis Chauvenet at one time president of the school, as special lecturer on mining and metallurgy.

Fatal Fire at Giroux Mines.—On the night of August 23, 10 men, comprising the night shift at the new shaft of the Giroux Consolidated Mines, at Ely, Nev., were caught by a fire originating apparently on the 1,200-foot level. The men boarded the cage, stopped at the 1,200-foot level, where half their number left in the endeavor to escape through the old Alpha shaft, 700 feet away, and the remainder continued to the surface. Those leaving at the 1,200-foot level were all overcome and killed, while of those who continued to daylight, one died on the trip, and the remaining four are in the hospital, seriously injured. It will be remembered that 3 years ago two men were killed and four others were entombed for 46 days on the 1,000-foot level of the Alpha shaft of this same mine.

The Forest of Dean Mine

An Old Iron Mine Producing High Grade Ore. Ancient and Modern Machinery Working Together

One of the oldest mines in the United States is known as the Forest of Dean, having been worked, according to Doctor Beck, so early as 1756. It is situated about 5 miles west of Fort Montgomery on the Hudson River, in Monroe Township, Orange County, New York state. The mine is in what is termed the Highlands of the Hudson. In such a location it is necessary to load and unload the ore twice to place it on the river boats or on the West Shore Railroad which skirts the river at Fort Montgomery.

The first stage of the ore transportation is in tram cars, which are hauled by steam locomotives for about three miles to a point on a high hill above a lake, where it is dumped into ore bins and loaded into Bleichert aerial tramway buckets which transport it to the loading bins on the Hudson. At one time it was carted from the mine railroad to Fort Montgomery. This, however, was when the mine was being worked by the Forest of Dean Iron Ore Co. and before it came into the hands of the present owners, the Hudson River Iron Ore Co. Previous to the latter's ownership the output was probably not over 90 tons per day, and this amount was subject to fluctuation in the iron-ore trade. The conditions which prevailed at that time were considerably different from those at the present time, for not only had this ore, which is non-Bessemer, to compete with the excellent ore from Tilly Foster mine, but also with the Lake Champlain and Sterling Iron and Railway Co.'s magnetites. Tilly Foster mine which was near Brewster, N. Y., has since then been worked out, and most of the Sterling Iron and Railway Co.'s mines that produced Bessemer ore have been abandoned. The ore is shipped to the iron blast furnaces on the Hudson, to those in New Jersey, and to the furnaces in Northeastern Pennsylvania. It is but recently that its output has been increased to 300 tons per day and this requires that the mine be worked night and day.

Magnetite is one of the common minerals in the crystalline rocks of the pre-Huronian. It occurs as an accessory mineral

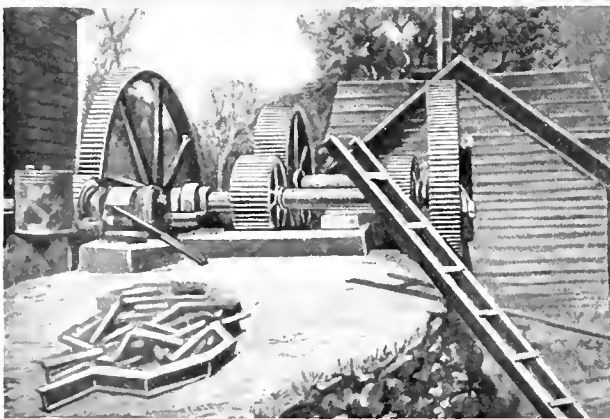

FIG. 1. PUMP GEAR AT FOREST OF DEAN MINE

in the granitic and gneissic rocks of the Highlands and in a more or less irregular belt of similar rocks which run through Orange and Rockland counties, New York, into New Jersey. The beds are not continuous in these rocks, but here and there the magnetite magmas have segregated, forming irregular-shaped pockets or thin-sheeted beds. The ore shows lamination and not infrequently coarse cleavage; it also varies to a certain degree at each mine in chemical and physical properties. In

instances the ore deposit may carry phosphorus, titanium, or sulphur in sufficient quantities to render that particular ore body practically valueless. The ore frequently varies in phosphorus content at the same mine, and the phosphorus mineral, being apatite, can be discerned with the eye. The crystallization also varies in the same bed from almost cryptocrystalline to coarse buckshot crystals. One deposit may have alternate thin beds



FIG. 2. HEAD-HOUSE, FOREST OF DEAN MINE

of ore and rock; another deposit horses of rock completely surrounded by ore; or again the rock may be continuous but may widen and thin in lens-like form along the strikes, the ore decreasing or increasing in quantity to conform with space occupied by the "horse," as at the Scott mine in Rockland County. Usually the ore is on both sides of the "horse." The beds are sometimes faulted and folded and the lenticular ore bodies thin out at the ends and with depth until they are lost completely. In general the strike of the ore is northeast and southwest with a dip southeast and the pitch or hade to the northwest.

The Forest of Dean ore body is a large prism-shaped mass 120 feet high by 90 feet wide, its form being due probably to its having been folded upon itself. It dips northwest at an angle of about 23 degrees and has been worked along this slope for a distance of about half a mile. The working slope is on the footwall which is gneiss. There is a horse of rock which divides the ore at the roof and which indicates that the magma was subjected to a synclinal fold. The most remarkable feature about this horse of rock is that it is granite with a small streak of trap rock frozen to it, a phenomenon which does not, it is believed occur at any other magnetite mine in the Highlands of the Hudson or in New Jersey, the horses in the other mines being usually feldspar and greenstone.

The gangue of this deposit was originally red and white feldspar, but pieces of gangue composed of red and white feldspar and a small quantity of white calcite are found with coarse magnetite crystals disseminated through it, giving it almost the appearance, when it is not closely observed, of the franklinite of Franklin Furnace, New Jersey. The ore is medium fine crystalline as a rule, but friable when inclining to shot-like structure. The ore as shipped averages more than 60 per cent. metallic iron and it is not difficult to pick specimens carrying 70 per cent. metallic iron. According to an analysis taken in the days of hand cobbing, the ore averaged about as follows: Silica, SiO_2 , 5 per cent.; alumina, Al_2O_3 , trace; lime, CaO , 5.51 per cent.; magnesia, MgO , 1.19 per cent.; oxide of iron, Fe_2O_3 , 83.56 per cent. = metallic iron, 60.5 per cent.; phosphoric acid, P_2O_5 , 2.30 per cent.; carbon dioxide, CO_2 , 1.05 per cent.; water, .20 per cent.

The mining is done in benches, the roof being supported by

pillars of ore left under the horse of rock which forms the upper part of the pillar. This leaves two series of stopes from which a large quantity of ore can be broken in a day. Air drills are used on the stopes, the compressor being so arranged that it can be run by steam or water-power, usually by the latter when the supply of water will permit.

The hoisting and pumping were at one time done by water-power, but the 40'x6' overshot waterwheels were not equal to the task of raising a large tonnage, and water-power hoisting was abandoned for steam power. The mine water is raised in a vertical shaft about 900 feet northeast from the mouth of the slope. In this shaft there is a 12-inch plunger pole pump that is run by waterwheels. The gearing for this purpose which was the only part available for illustration, is shown in Fig. 1, mounted on a high masonry foundation. The waterwheel is

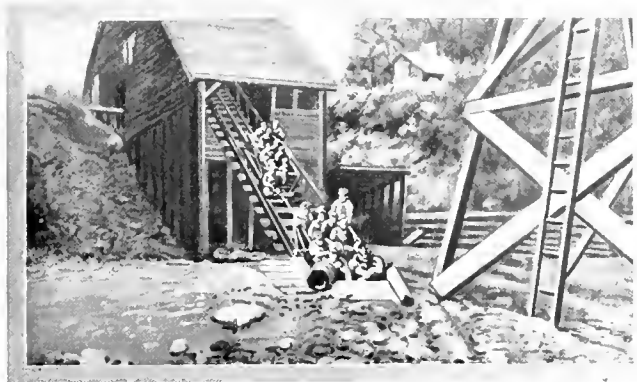

FIG. 3. SHIFT GOING INTO THE FOREST OF DEAN MINE

geared to the large wheel to the left and the crank-wheel on the right to the intermediate gears. To the right of the crank-wheel is shown the pitman that works the walking beam or pump bob inside the house to the rear of the gear train. The L to this house covers the shaft. The more one considers the difficulties with which the early mining engineers had to contend, the more respect one must have for their ingenuity; and when it comes to mining the ore, their methods of working seem to be as up-to-date as those of the present generation. This, of course, does not apply to the use of machinery but to the methods of mining.

A view of the head-house at the Forest of Dean mine is shown in Fig. 2. The ore is hoisted up the slope in cars to the top of the head-house (which is arranged so as to be a continuation of the slope) and is dumped automatically over a grizzly. The ore that needs crushing passes over a grizzly to a jaw crusher, from which it falls to a traveling belt. The fine ore goes directly to the ore bins. The traveling belt is the picking belt from which the small quantity of rock which is in the ore is picked by men accustomed to the work. The ore remaining on the belt passes up an incline and drops to the loading pockets, from which it is loaded by gravity into the tram cars to be hauled to the wire rope tramway. When sufficient rock has accumulated in the rock bin it is loaded by gravity to cars and hauled to the nearby dump pile. The tower in the foreground carries the hoisting rope to the hoister situated some distance away toward the pump shaft. This arrangement while awkward, answers every purpose and concentrates the machinery where the coal can be delivered handily. Electric signals are arranged to connect top and bottom of the shaft, the head-house, and the engine room.

At the place marked *a*, Fig. 2, are seen the remains of an old Catalan forge that was used probably in the time of the Revolution if not previously. The fortifications along the west bank of the Hudson and so on through Orange and Rockland counties were evidently to hold the British in check and prevent their capturing the mines, which produced the iron so much needed for weapons by the Continentals. This old forge was

constructed of sandstone walls, and pieces of sandstone are found with the slag melted to them so intimately as to make it necessary to break the stone to separate the two.

Taken as a whole the Forest of Dean ore deposit is one of the most interesting magnetite deposits to be found in the United States, and the whole plant with its modern and antique machinery is about the only mining proposition in the East which now unites the present with the past.

來 來
Duralumin

Duralumin is the name given to a series of light and tough alloys, invented by Herr A. Wilm, of Schlachtensee, near Berlin. One of this series contains 90 to 95 per cent. of aluminum, and has nearly the same properties as good Bessemer steel, except that its specific gravity is only about 2.8. This metal has great value not only for aviators but also for manufacturers of cartridges. For this manufacture a hardness of 160 at the base is required to prevent expansion with the blow of firing. The hardest alloy of this series reaches 125 in its natural state, which may be increased by cold hammering to 174, taken by the Brinell test. By using one of the hardest of the alloys and treating the metal hot, the hardness is reduced so as to lighten the operations to which it is submitted. For airships the stretch under extension must be over 8 per cent. Tests show that the new alloy breaks at 88,000 pounds per square inch.

來 來
An Ore Mine Tromp

By Harold Lakes

As ventilating a mine is a problem that is of interest to all miners, the method described in the drawing will perhaps solve some of the difficulties. Unlike many other ventilating apparatuses, it costs nothing after it is once installed and goes on at all hours, day and night.

Fig. 1 shows a method of ventilating a mine by the use of the water it makes. This method is common in many camps but seems to be unknown in others.

A tunnel can be ventilated for 1,000 feet or more if ample water flows from it. As the water flows from the tunnel into the flume, it is carried out on to the dump until it reaches a point where it can have a fall of about 15 feet or more. Then

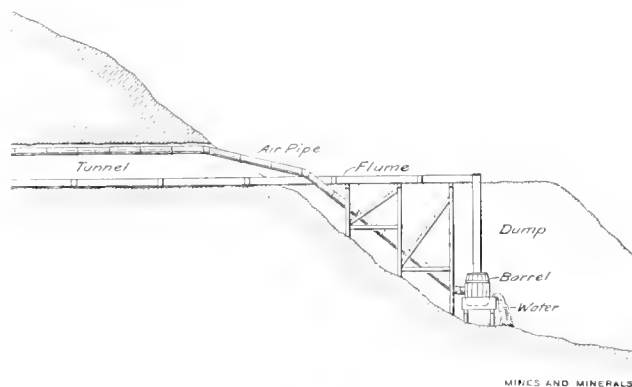

FIG. 1. ORE MINE VENTILATOR

it falls through a box made of four boards nailed together as nearly air-tight as possible. This box is connected to the inverted barrel as shown. The connection should be air-tight. The air pipe from the tunnel also connects with the barrel about in the middle of the side. This inverted barrel sets in a box which must be a few inches above the bottom of the barrel. The water as it flows from the bottom of the barrel rises over the box and flows away as indicated. The water flowing out in this manner and dropping some 15 or 20 feet causes a suction which will almost put out the flame of a candle in 1,000 feet through a 6-inch air pipe.

Copper Smelting Furnaces

Recent Practice in Construction. Method of Calculating Capacities of Given Sizes

By Chas. C. Christensen

Before deciding on the proper plant for the smelting of copper ore, it is absolutely necessary to determine whether it will be more profitable to convert the copper of the ores to be treated into a "matte" or into black copper; that is, into unrefined metallic copper. This question depends almost wholly upon the character of the ore whether it is sulphide or oxide. The main circumstance which determines the production of either matte or black copper, or of both products in smelting copper ores, is the presence or absence of sulphur in the ores or in the smelting mixture. If we have to deal with sulphuret ores, or with ores which contain sulphurets or sulphates, the production of matte will depend on the degree of preliminary roasting to which the ores have been subjected before they are melted in the cupola.

After deciding on these matters and erecting a plant suitable for the desired product, the success of the smelting depends in such large degree on no other single condition as on the proper composition of the smelting charge as it is put into the furnace. It is the province of the metallurgist in charge of the works to determine the proper composition of this smelting mixture and to give the directions for making this mixture out of the different ores and fluxes, which are available in each case.

For small plants there are two methods of making smelting mixtures. One way, which is followed frequently, is to keep each kind of ore and flux separate in different bins, and to weigh a certain quantity of each class of ore and flux constituting the smelting charge, separately for each charge; dump these together at the charge door of the furnace, and mix them as they are thrown into the furnace, a horizontal layer in alternation with fuel. This method leaves the correctness of the smelting charge altogether to the care and attention of the weigher and feeders. Another plan, much more to be commended, is to mix the different ores in the proper proportions in large quantities, and to draw from this mixture such quantities as are wanted for a single charge, thus leaving only the correct weight of the whole charge to the weigher, and not the correct proportion of the different ores and fluxes. This method is evidently the safer of the two.

The capacity of a blast furnace, in tons of ore, depends chiefly upon the quantity of fluxes required, pressure and volume of blast and the fusibility of the charge.

The size of a furnace is determined by its internal area at the tuyere level. The limit of width has been found to be 54 inches for rectangular furnaces and consequently 54 inches diameter is also the limit of round furnaces. For the length of a rectangular furnace there seems to be no limit, furnaces over 100 feet in length are in operation in the United States today. The smaller sizes of round furnaces will smelt approxi-

mately $4\frac{1}{4}$ tons of ore and fluxes per square foot of area at the tuyere level per day of 24 hours. Following this rule a round copper smelting furnace of 20 tons capacity per 24 hours should have an area at the tuyere line of $\frac{20}{4\frac{1}{4}}=4.7$ square feet or about

30 inches diameter. A 30-ton furnace should have an area of $\frac{30}{4\frac{1}{4}}=7.06$ square feet or 36-inch diameter and a 50-ton furnace

$\frac{50}{4\frac{1}{4}}=12$ square feet or about 48-inch diameter. For

larger rectangular furnaces this rule must be modified. At Washoe smelter, Anaconda, when they were running an 87-foot long furnace, they treated as much as 2,800 tons of charge per day of 24 hours, which, figuring maximum width 54 inches, will give a smelting capacity of 7 tons per square foot of area at the tuyere line. This furnace has since been lengthened to 126 feet.

For middle-size rectangular furnaces, smelting capacity, however, will not exceed 5 to $5\frac{1}{2}$ tons per square foot of area, or, as an example, 450 to 500 tons per 24 hours for a $54'' \times 240''$ furnace. Small rectangular furnaces will even run as low as the round furnaces. A 44 in. \times 96 in. for example, should not be rated over 100 tons capacity.

Fig. 1 shows a well-designed round copper furnace. The bottom of the furnace consists of a heavy cast-iron plate resting upon four short columns and having hinged drop doors under the bottom of the furnace shaft. The water-jacket is of steel plates, the inner plate being flanged out and connected to the outer plate by a riveted joint on the outside of the jacket, leaving the inner shell completely smooth without any rivets or staybolts exposed to the heat. The outside sheet of the jacket is extended down to the bottom plate to form the curb of the furnace. A sheet-steel wind box encircles the outside of the jacket, suitable tuyere openings being provided from the wind box into the interior of the furnace. Above the jacket is a sheet-steel hood of conical shape provided at the feed-floor level with an opening for charging the furnace. The hood terminates in a steel stack passing up through the roof of the building. These round furnaces are manufactured in different sizes and of the smelting capacity referred to above.

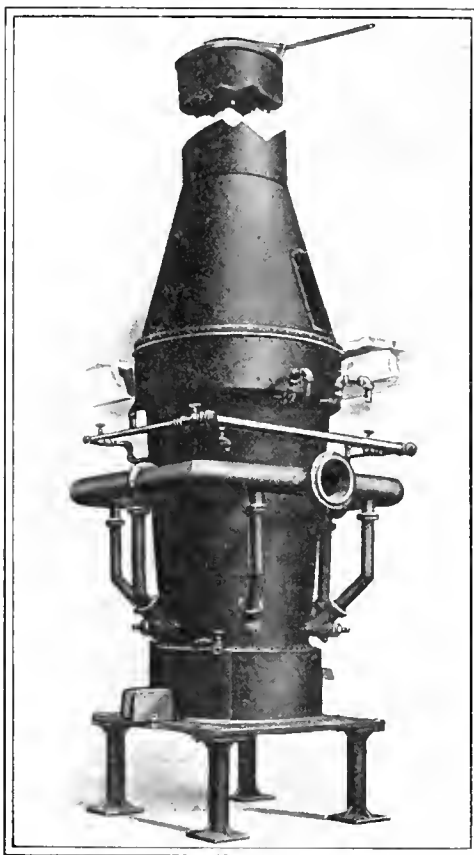

FIG. 1. ROUND COPPER FURNACE

Fig. 2 illustrates an up-to-date rectangular copper smelting furnace. The bottom of this furnace is formed by a heavy cast-iron plate, resting upon cast-iron columns placed on the furnace foundation. The jackets rest directly upon the bottom plate, but are also supported from the mantle frame by suitable hangers, so that when the bottom plate is lowered the jackets remain in position suspended from the mantle frame. The jackets are made in sections of steel plates with joints on the outside, and are stayed between the inner and outer sheets by crowfoot steel stays. No rivet heads appear anywhere on the inner sheets of the jackets. One side jacket section is provided with a recess at the base for a rectangular tapping jacket used for draining the furnace when blowing out of service. One end jacket is provided at its base with a recess for inserting a rectangular breast jacket, in front of which the trap spout is set and through which the molten material flows to the settler. The breast jacket and trap spout are made either of bronze or

of steel plates, as they are constantly in use and require very durable materials to give satisfactory service. All jacket sections are provided at their edges with strong lugs and bolts for securing them to each other, and the entire set is bound by steel I-beam binders on each side, and both ends of the furnace held together at the corners by strong U bolts. All jackets are provided with inlet and outlet connections for cooling water and handholes at the base for cleaning.

The tuyere boxes are bolted rigidly to the back of the jackets and connected to the bustle pipe by light steel tubing. The bustle pipe is made of steel plate provided with a main flanged nozzle for connecting it with the main blast pipe, and suitable nozzles on each leg for connecting the tuyere pipes.

The mantle frame is of heavy steel I beams and rests upon four cast-iron or steel columns at the corners of the furnace. A cast-iron plate rests upon the mantle frame, forming a base for the brickwork of the shaft. The furnace shaft is made of good common brick and lined on the inside with 9 inches of firebrick. At the charging-floor level openings are provided in each side of the shaft, the full length of the shaft, for charging the furnace. The bottom and sides of these openings are protected by heavy cast-iron plates and the top of the opening is formed by a steel I-beam lintel frame which carries the brickwork of the shaft above the charging openings. Stationary light steel curtains hung from the lintel frame are provided to cover the charging opening to within 12 to 18 inches of the floor level, leaving just opening enough below the curtain to shovel the charge into the furnace. The curtains can be easily removed for barring down, furnace inspection or other purposes. The top of the furnace is covered by a pyramidal-shaped steel hood terminating in a connection for a round steel stack and downtake.

These rectangular copper-smelting furnaces are made in different widths and lengths to suit capacity and locality, as already referred to above.

來 來

Joplin Zinc Notes

James F. Callbreath, Secretary of the American Mining Congress, with temporary headquarters at Washington, D. C., has appointed B. K. Blair, of Joplin, a member of a special committee of five to aid in securing mining statistics. George W. Riter, of Salt Lake City, is to be chairman of the committee. A. W. Warwick, of Denver, is another member of the committee. The remaining two have not been named. The resolution creating the new committee was adopted at a recent meeting of the members of the Utah chapter of the Congress. Mr. Blair is secretary of the Zinc Ore Producers Association.

After numerous delays due to caving ground, the Tri-City Mining Co., under the new name of the S. V. & D. Mining Co., has begun operations on a large scale in the Carthage, Mo., camp. Homer P. Sewell, former owner of the mine, recently sold the property to eastern capitalists, who intend to erect a concentrating plant with a capacity of 200 tons per shift.

Sublessees on the Paoma Mining Co.'s land in the west part of Joplin are sinking to the 160-foot level where ore has been located in drill holes. Previous operations have been conducted at a depth of 100 feet.

The Stolfus-Cassel mine on the Berry & Pieksen lease of the Pinkard land, at Joplin, has been sold to George Dimmick, Jr., of Huntington, W. Va., and L. H. Gornley, of Joplin, for \$4,000. Ore, which is found in soft ground at a depth of 112 feet, is treated on hand jigs.

The Moler-Smith Mining Co., operating an open-cave mine in the Carl Junction, Mo., camp, has ordered a core drill which is expected to arrive in April. The bottom of the open pit is now 80 feet, and in this floor the first core drill holes are to be sunk to a depth of 500 feet. Core drilling was introduced into the Joplin district last fall by the Oronogo Circle Mining Co., and it has proven successful. Another company planning to operate a core drill soon is the White Dog Mining Co., working in the sheet-ground area north of Webb City, Mo.

A remarkable depth of ore development has been attained at the Center Creek Mining Co.'s property, in the Webb City, Mo., camp, when it is taken into consideration that this tract was one of the pioneer grass-root producers of the district. For years the land turned out heavy shipments of zinc and lead ores from shallow gouges, the ore being found within a few feet of the surface. Gradually operations have been extended deeper, the ore formations being almost continuous down to the 200-foot level at which depth two leasing companies, the Pasadena Zinc Co., and the Mercedes Mining Co., are now operating. The latter company is producing ore which runs 10 per cent. in zinc blende, with some lead.

Six miles east of Carthage, Mo., a district that has been dormant for years is taking on new life and several good producers of calamine, zinc blende, and lead are being opened. The new mines are in the Reeds Station camp and much of the development is of a comparatively shallow nature. Among the steadier producers are the Lone Star and the Magnet mines, while a new property known as the Jack Rabbit is beginning to find its way into the list of the producers. Another property that is attracting attention is the Sampson mine, where a large deposit of pocket ore has been blocked out.

In the Quapaw, Oklahoma, camp, where many of the mines were closed because of the scarcity of water, opera-

tions were resumed following the heavy rains early in March. The drought resulted in a big curtailment in the ore production from that camp. Farther to the southwest the mines of the Miami, Okla., camp are running steadily but are selling little ore, the turn-ins since the first of the year having been insignificant. As a result the surplus of zinc blende has grown to approximately 4,000 tons, the largest surplus of any single camp in the district. Producers are holding for higher prices.

William Lanyon, a multi-millionaire of St. Louis, will be in the market for Joplin zinc ores again within a year if his reported plans to erect a large zinc smeltery at Hillsboro, Ill., materialize. Mr. Lanyon formerly operated zinc smelteries on an extensive scale in Pittsburg, Kans.

C. S. Bankard has purchased the Alpha mine at Spring City, Mo., from Adam Scott. He intends to increase the capacity of the mill, which now handles 100 tons per shift. Prospect drifts, at a depth of 105 feet, have been driven into encouraging ore formations.

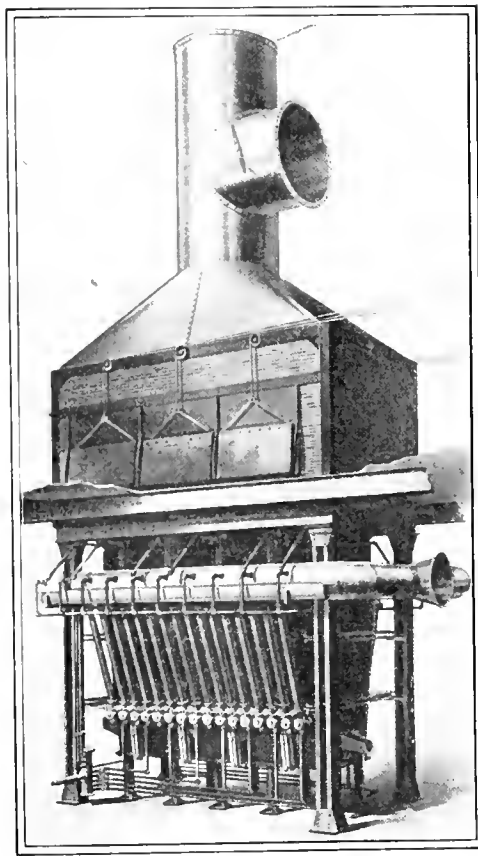

FIG. 2. RECTANGULAR COPPER FURNACE

Calculations in Ore Concentrations

Method of Algebraic Calculations for Close Regulation of Concentrating Operations

By Rudolph Gahl, Ph. D., Morenci, Ariz.*

The size of American concentrating plants, especially of those treating copper ore, has very greatly increased in recent years. When we consider the enormous sums of money represented by the ore treated in these plants and how great might be the financial loss due to slight errors in mill operation, the necessity of keeping close watch on the work becomes apparent.

It is not possible to so thoroughly control a plant of this kind as it is to regulate, say, an electric central station, where a number of ammeters and voltmeters will indicate precisely the operation of the plant. The best indicators which the concentrating man has at his command are screen tests and assays, but a great deal also depends on his ability properly to interpret the readings of these indicators. To do this successfully requires the application of some mathematics, and it is my desire to show in this paper how much can be done in this direction by simple algebra. I do not claim that the relations that I shall develop are new, for others have already applied algebra to problems of ore dressing; but the methods used and results obtained do not seem to have become well known, probably because the textbooks give but little, if anything, on the subject. It is my hope that by communicating the information to this Association, I may save others the trouble of working out such problems for themselves.

The Value of the Assays.—Let us consider in the first place the information which the assays of heads, concentrates and tailing will give us regarding the saving which a concentrator is making. Let x equal the weight of the ore put into the mill, with y and z the respective weights of concentrate and tailing produced from the x quantity of ore. The assays of ore, concentrate, and tailing may be designated by a , b , and c , respectively.

Then the two facts, that the weight of ore equals the combined weights of concentrate and tailing, and the amount of copper, or other valuable constituent, in the ore equals the combined amount of copper in concentrate and tailing, are expressed by the two equations,

$$x = y + z \quad (1)$$

$$ax = by + cz \quad (2)$$

The absolute quantity of ore milled is immaterial to the calculation of the saving, inasmuch as these equations apply equally well to large or small amounts of ore passing through the mill. Therefore we may consider the treatment of 1 ton of ore, and make $x = 1$. Our equations then become,

$$1 = y + z \quad (1a)$$

$$a = by + cz \quad (2a)$$

If we eliminate z between these equations we get,

$$y = \frac{a - c}{b - c} \quad (3)$$

Now y , according to our definition, is the weight of concentrate produced from 1 ton of ore. We will get the saving by dividing the amount of copper in the concentrate by the amount of copper in the 1 ton of ore, or the saving which may be represented by S , is expressed by the equation,

$$S = \frac{by}{a}$$

Substituting this deduced value of y in equation (3) we get the following equation for the saving,

$$S = \frac{b(a - c)}{a(b - c)} \quad (4)$$

This formula contains no weights and it is clear, therefore, that the saving of a concentrating plant may be calculated from the assays of the ore, concentrate, and tailing without knowing

anything about the quantities used or obtained. For example, a concentrator operating on 3-per-cent. copper ore may produce concentrate carrying 17 per cent. *Cu* and tailing with .7 per cent. *Cu*. What saving has been made? Substituting the values in formula (4) we find approximately 80 per cent.

In plants where ore and concentrate are weighed (the weight of the tailing being taken by difference), the results of this formula can be checked against the saving calculated by other methods. There are three more possibilities, which in our terms are as follows:

$$S = \frac{by}{ax} = \frac{\text{copper in concentrates}}{\text{copper in ore}} \quad (5)$$

$$S = \frac{by}{by + cz} = \frac{\text{copper in concentrates}}{\text{copper in concentrates and tails}} \quad (6)$$

$$S = \frac{ax - cz}{ax} = \frac{\text{copper in ore} - \text{copper in tails}}{\text{copper in ore}} \quad (7)$$

If the weights and assays are all correct, these four methods should check. In practice, of course, they do not check exactly. An example of the results obtained by the four methods in a certain copper concentrator, for several consecutive months is as follows:

Method of Calculation		Saving		
(1)	Assays only.....	77.48	78.59	80.33
(2)	Weights, and assays of ore and concentrate.....	78.09	80.73	79.00
(3)	Weights, and assays of tailing and concentrate.....	77.61	79.11	80.02
(4)	Weights, and assays of ore and tailing.....	77.52	78.69	80.27

These four methods of calculation are not independent of each other. If the amount of copper in the ore as calculated from weight and assays equals exactly the amount of copper in concentrate and tailing as calculated from their weights and assays, all four methods will give the same results; but if there is a discrepancy, the methods will give discordant results. In the latter case it will depend entirely on specific conditions which method is the most trustworthy; whether, for example, one sample is more reliable than another, or whether the weights can be relied upon, etc.

In the derivation of the formula for the saving calculated from assays only, equation (3) has special interest.

If we recall that y means that fraction of the ore which makes up the concentrate, we see that it is equivalent to the "rate of concentration." For instance, in the example of an ore carrying 3 per cent. copper, and giving concentrate of 17 per cent. and tailing of .7 per cent. copper, we would find for y the value .141, or expressed as a common fraction $\frac{1}{7.09}$,

which is equivalent to the statement that 7.09 tons of ore have produced 1 ton of concentrate, or that the ore has been concentrated 7.09 into one.

This equation is interesting from another standpoint. The rate of concentration is expressed by the assays of the ore, concentrate, and tailing; therefore it will hold true for copper, gold, or silver assay, or any other set of chemical determinations. All of these determinations cannot be made with equal exactness, and when we have a practical problem of determining the rate of concentration from a set of assays, such determinations will be chosen as are most reliable.

On the other hand, the fact that the rate of concentration can be calculated in so many ways, permits us to eliminate y and compare the different assays directly. If, for example, a, b, c , represent assays for gold; a_2, b_2, c_2 , assays for sulphur; and a_3, b_3, c_3 , assays for iron or any other constituents in ore, concentrate, and tailing, respectively, the relations will hold true, thus:

$$\frac{a - c}{b - c} = \frac{a_2 - c_2}{b_2 - c_2} = \frac{a_3 - c_3}{b_3 - c_3}, \text{ etc.} \quad (5)$$

* Reprinted from the *Western Chemist*.

I have not at hand any assays to show the application of this equation, but it is clear that it will allow the calculation of a complete analysis of the tailing if a complete analysis of the ore and concentrate and only one assay of the tailing be given.

Value of Screen Tests.—Thus far we have been considering only the information which the assays give in solving problems that come up in ore concentration. Let us now introduce the sizing screen and see what additional information we can gain by its use.

Take for example a problem of this kind: A certain concentrator disposes of its tailing in the following manner: After classification in cone classifiers, the spigot discharge contains the coarse sand with a little water, and is used to build a dam across the mouth of a gulch adjoining the tailing end of the plant. The overflow is conducted into the basin thus formed, where the suspended solid matter settles, liberating clear water which is again used in concentrating. The question arises, what percentage of the tailing goes to the dam and what percentage to the pond. This problem can easily be solved by making some sizing tests on the general tailing and the two products of classification mentioned.

Let the total quantity of the tailing be represented by x ; that part going to the dam by y , and the portion going to the pond by z . Then we have the equation,

$$x = y + z \quad (6)$$

If we screen the samples of each material on, say, a 100-mesh screen, we will have a certain fraction of each sample remaining on the screen which we will call α_{100} , β_{100} , and γ_{100} . If we screen a general tailing sample we will evidently get the same percentage of 100-mesh material as if we split this sample into the part which builds the dam and the part which feeds the pond, screened these two samples separately and combined the corresponding sizes. This fact is expressed by the equation,

$$\alpha_{100} x = \beta_{100} y + \gamma_{100} z \quad (7)$$

Since these two equations in no way depend on the actual quantity of tailing represented by x , we can make $x=1$. Then,

$$1 = y + z \quad (6a)$$

$$\alpha_{100} = \beta_{100} y + \gamma_{100} z \quad (7a)$$

or by the elimination of z ,

$$y = \frac{\alpha_{100} - \gamma_{100}}{\beta_{100} - \gamma_{100}} \quad (8)$$

This equation naturally holds true for any other screen size and if we screened on a 200-mesh screen we would have,

$$y = \frac{\alpha_{200} - \gamma_{200}}{\beta_{200} - \gamma_{200}} \quad (8a)$$

The screen to be used in a given case depends on the material to be screened, the principal point to be observed being the selection of the screen which will give the most nearly correct results. It is to be understood that screening does not give exact results, for no screen is absolutely uniform; but those who have made wet screen tests often enough to become proficient will admit that screening on fine sizes, say from 100-mesh down, is fairly accurate. Although the error in screening expressed in percentages may be greater than the error in assaying, there are cases in which the results based on screen tests are much more reliable.

In the case under consideration the screen tests were as follows: Percentage on 100-mesh, general tailing, 44.4; tailing to dam, 75.2; tailing to pond, 3.1.

Substituting the screen results on 100-mesh screen in our formula, we find that 57.3 per cent. went to the dam and the balance of 46.7 per cent. to the pond.

This problem could have been solved from the assays only. The same set of samples used for the screen test was assayed with the following results:

	Cu Per Cent.
General tailing.....	85
Tailing to dam.....	72
Tailing to pond.....	16

Our formula (3) will solve this problem. Although we have deduced this formula for relations existing between ore, concentrate, and tailing, it holds for any case in which one product is split into two other products, or where two different products are combined into one. I must emphasize the fact that the two products into which one is split, or which are combined into one, must be different, for if they are the same the problem cannot be solved and if they are nearly alike the error in the result will be great. Therefore if there is but little difference in the assays of the products, screening will give better results, but if the material is of practically the same size the assays should be the basis of the calculation. Returning now to dam problem, let a represent the assay of the general tailing, b the assay of the coarse tailing and c the assay of the fine tailing; y will represent the fraction of the tailing going to the dam. Using these assays in the formula we get as a result,

$$y = 70.5 \text{ per cent}$$

This is decidedly different from the figure 57.3 per cent. which we obtained from the screen tests, and is evidently not reliable. This is due to the fact that the differences between the assays of the three products are so small that they are not a safe basis of calculation. This, then, is a case where screen tests give much more reliable results than assays.

That the assays are really conformable with the screen tests can be shown by calculating the assay of the general tailing from the assays of the coarse tailing (dam) and the fine tailing (pond), making use of the proportion between the two found by screening. The calculated general tailing assay, according to this, would be,

$$a = bx + cy$$

$$a = .91 \text{ per cent. } Cu$$

This checks the actual assay within the limits of the ordinary cyanide assay for copper, and shows that the results by assaying have not contradicted the results obtained by screening.

But we are able to solve this problem in still another way, by considering the percentage of water carried by each one of the materials in question. We have the equation for the dry pulp,

$$a = b + c \quad (9)$$

If we call the weights of the wet pulps A , B , and C , respectively, the following equation is also true,

$$A = B + C \quad (10)$$

If a , β , γ , represent the percentages of solid matter in A , B , and C , respectively, we will have the following equations:

$$a = A\alpha \quad A = \frac{a}{\alpha} \quad (11)$$

$$b = B\beta \quad B = \frac{b}{\beta} \quad (12)$$

$$c = C\gamma \quad C = \frac{c}{\gamma} \quad (13)$$

Substituting these values in equation (10) it follows,

$$a = \frac{b}{\beta} + \frac{c}{\gamma} \quad (14)$$

Since it is again unessential what quantities we consider, make $a=1$. Then,

$$1 = b + c \quad c = 1 - b \quad (15)$$

$$1 = \frac{b}{\beta} + \frac{c}{\gamma} \quad (16)$$

By eliminating c in the two equations

$$b = \beta(1 - \gamma) \quad (17)$$

$$a(\beta - \gamma)$$

The moisture samples taken gave the following results,

$$\alpha = 13.1 \text{ per cent. solids}$$

$$\beta = 42.5 \text{ per cent. solids}$$

$$\gamma = 6.9 \text{ per cent. solids}$$

By substituting these figures in our equation

$$y = 59.5 \text{ per cent.}$$

which represents the percentage of dry tailing that would go to the dam. This checks the result obtained from the screen tests, which was 57.3 per cent.

It happens, however, that problems in the distribution of tailings are as easy as this one. If three products are combined into one, or one is split into three, the calculations are more complicated. For example, a concentrator produces three final tailing products, by the following treatment: the coarsest ore is treated on Wilfley tables, the next finer on one set of vanners, and the finest on still another group of vanners. The tailings from all three sets of machines are combined into general tailing. The question arises, what percentage of the general tailing originates from the Wilfley tables, and what percentage from each set of vanners. This question could be solved by screening the different tailing samples. Let us call,

a_{30} the fraction of general tailing remaining on 30-mesh screen.

b_{30} the fraction of Wilfley tailing remaining on 30-mesh screen.

c_{30} the fraction of 1st vanner tailing remaining on 30-mesh screen.

d_{30} the fraction of 2d vanner tailing remaining on 30-mesh screen.

a_{200} the fraction of general tailing on 200-mesh screen, passing 30-mesh.

b_{200} the fraction of Wilfley tailing on 200-mesh screen, passing 30-mesh.

c_{200} the fraction of 1st vanner tailing on 200-mesh screen, passing 30-mesh.

d_{200} the fraction of 2d vanner tailing on 200-mesh screen, passing 30-mesh.

β the fraction of Wilfley tailing in general tailing.

γ the fraction of 1st vanner tailing in general tailing.

δ the fraction of 2d vanner tailing in general tailing.

Actual screening showed that only a portion of the general and Wilfley tailing remained on the 30-mesh screen, and the vanner tailing contained only negligible portions of such material. This furnishes the equation,

$$\beta b_{30} = a_{30} \quad \beta = \frac{a_{30}}{b_{30}}$$

from which β can be calculated.

For the screenings passing through 30-mesh and remaining on 200-mesh the following equation will hold true,

$$\beta b_{200} + \gamma c_{200} + \delta d_{200} = a_{200}$$

But according to our assumption,

$$\beta + \gamma + \delta = 1$$

and by eliminating δ we get

$$\gamma = \frac{a_{200} - d_{200} - \beta(b_{200} - d_{200})}{c_{200} - d_{200}}$$

The actual screen tests for one day were as follows:

$$\begin{array}{ll} a_{30} = 17.7 & a_{200} = 36.8 \\ b_{30} = 40.7 & b_{200} = 53.9 \\ & c_{200} = 44.0 \\ & d_{200} = 9.3 \end{array}$$

The calculation gives the following results,

$$\beta = 43.5 \text{ per cent.}$$

$$\gamma = 23.3 \text{ per cent.}$$

$$\beta b_{200} + \gamma c_{200} + \delta d_{200} = a_{200}$$

$$\beta + \gamma + \delta = 1.$$

The elimination of γ furnishes the equation,

$$\delta = \frac{a_{200} - c_{200} - \beta(b_{200} - c_{200})}{d_{200} - c_{200}}$$

$$\delta = 23.3 \text{ per cent.}$$

As a check on this calculation $\alpha + \beta + \gamma$ may be formed which should add up to 100 per cent.

This may be sufficient to show how similar problems may be solved. If it is necessary frequently to determine what percentage of the total tailing originates from the different machines in a concentrator it may be wise to install mechanical appliances for this purpose. At my suggestion the Detroit Copper Co. has done this in the following way: The tailing launders from the different groups of machines are conducted separately to

the bottom of the mill. There separate sample slots are provided for the discharge from each launder. These slots are of equal width and are operated by the same mechanism, consequently the samples cut out by them are proportional to the total amount of tailing. I may mention, by the way that the three streams of tailing are combined after passing their respective sampling slots and that a sample of this general tailing product is taken through a slot which is operated by the same mechanism that actuates the three sampling devices mentioned above.

Of course the assay of the general tailing can be calculated from the weights and assays of the three separate tailing samples. The comparison between the calculated and assayed general tailing sample furnishes a check on the work of sampling and assaying.

Distribution of Pulp.—The question may be asked whether it is of so great importance to know just how the pulp is being distributed in a mill, and whether the mill man cannot tell from the appearance of his machines whether the distribution is correct. A comparison between actual determination and estimates from appearances of the machine has shown that such estimates are in no way trustworthy. There will be one distribution of pulp which will give the minimum loss, and the only question is whether the results obtained by that distribution are sufficiently better than any others to warrant exact determination of the proper conditions. I will try to illustrate this by again referring to a practical case. In a certain concentrating plant two vanner feeds are made. The separation of the two feeds is made in V-shaped box classifier in which, however, no hydraulic water is used, so that only a rough classification is made, throwing the greater part of the sand and the smaller part of the slime to the first set, and the rest of the sand and the bulk of the slime to the second. The question now arises, how much feed should each set of vanners carry?

Some tests showed that if the best possible saving of copper was desired, only a very small feed should be carried per machine, and that increasing this load increased the loss of metal. But such a policy could not be carried out in a commercial plant as the question of operating cost would enter. An extremely light load would be impossible, for only a relatively small profit would remain after deducting operating costs, which in the case of a small load would form a serious item.

Let us call metallurgical saving the percentage of valuable metal recovered. If we deduct from this figure as many per cent. as would pay for the operation of the machine, we will get what we may call commercial saving. Now the commercial saving is the best, or expressed mathematically, has a maximum for a greater load. Assuming, for example, a copper value of 15 cents per pound, curves may be drawn which it is assumed will represent commercial saving for the coarser vanner feed, as $5\frac{1}{2}$ tons, and the finer vanner feed, as 8 tons.

This would mean that the feed should be distributed between the first and second sets of vanners in the proportion of 11 to 16 in order to get the most economical load, and it shows the value of the method in guiding the concentrator foreman in the distribution of pulp. In arriving at this conclusion the assumption has been made that by changing the size of the classifier spigot discharge, the nature of the two feeds is not changed. This assumption will be safe when the existing distribution is not very different from the one found best by the method.

The result indicated; viz., that a vanner treating a coarse feed should receive a smaller load than a vanner treating a slime feed, may seem surprising in view of the fact that a slime table should receive a very small load in order to make a good saving. I think also the fact that a slime vanner carrying its best load will make high tailing and a vanner treating coarse material will produce low tailing would induce some mill managers to take the feed away from the slime machines and increase the load on the coarse.

Nevertheless, considered from the standpoint of the curves

this would be a mistake. The explanation lies in the fact that this slime feed contains such a large percentage of what has been called absolute slime, on which concentrating machines cannot effect a saving by any means, that the proportion of copper that can be saved is very small and would not pay for the operation of the large number of machines necessary to save it. A coarser feed, however, contains only a small percentage of this extremely fine slime, and for this reason the recovery will be high in every case. But even though it may be high already, it may pay to try to increase it by distributing the pulp over more machines.

There is one point that I would like to emphasize in this connection; that the tailing assay gives no information regarding the work which a machine or plant is doing. The only criterion is, does the tailing contain mineral in a form that can be saved by wet concentration. It is not easy to determine this point and the only place where its determination is attempted, as far as I am aware, is in the concentrator of the Green Cananea Co., Cananea, Mexico. Although the methods in use for this purpose may not be perfect, it seems to me that by adopting some such plan we shall be able to distinguish between avoidable and unavoidable losses and learn to eliminate the former.

來 來

Lake Superior Mining Institute Meeting

The sixteenth annual meeting of the Lake Superior Mining Institute, which was held on the Minominee Range, August 22, 23, and 24, was successful in every way. To furnish sleeping accommodations for the members and visitors, three Pullman cars were chartered by the committee of arrangements so that with these, the hotel, the four private cars, and private houses, none were obliged to remain up all night. During the first day and night the session was held at Crystal Falls, the county seat of Iron County. Here the ore dryer at the Hollister mine was inspected and the Tobin and Bristol mines visited. In the early evening the members were entertained with a barbecue and vaudeville at Idlewild by the Crystal Falls Commercial Club, and later a business-session was held at the Court House. Alexander M. Gow gave an interesting and instructive illustrated lecture on "Some Safety Devices of the Oliver Iron Mining Co."

Wednesday the members and visitors left Crystal Falls by special trains to visit the Baltic and Caspian mines. After a social session at the Baltic mine club house, trains were taken to the Caspian mine. From the Caspian mine the trains went to Iron River where the second session was held, at which F. W. Denton and Graham Pope, both of Houghton, were elected president and vice-president, respectively, and it was decided to hold next year's meeting at Houghton, Mich. During this session the following papers were read: "Surveying and Sampling Diamond-Drill Holes," by Edwin E. White, Ishpeming, Mich.; "Tobin Mine Sub and Caving System," by Fred. C. Roberts, Crystal Falls, Mich.; this paper was read by Professor Speer, as Mr. Roberts, being president, occupied the chair; he took part, however, in the discussion; "The Relation of Mining Interests to the Prevention of Forest Fires," by Thos. B. Wyman, Secretary-Forester, Munising, Mich.; "Square Set Mining," by Floyd L. Burr, Vulcan, Mich.; "Top Slicing and Caving System in Stambaugh District," by W. A. MacEachron, Iron River, Mich.; "Check System of Time Keeping," by Jas. D. Vivian, Crystal Falls, Mich.; "Boiler Setting and Coal Handling," by J. S. Jacka, Crystal Falls, Mich.; "Electrical Operating Plants of Penn Iron Mining Co.," by Frank H. Armstrong, Vulcan, Mich.; "Social Surroundings of the Mine Employee," by C. E. Lawrence, Iron Mountain, Mich. Besides these several others were read by title.

William Kelly, general manager of the Penn Iron Mining Co., requested that Charles Kirchhoff, president of the American Institute of Mining Engineers, be called on for a speech. During

some happy remarks he suggested, as this was an era of combinations, that the Lake Superior Mining Institute affiliate with the American Institute of Mining Engineers. This suggestion was later put in the form of a motion by Mr. Kelly and carried. It does not mean, however, that the Lake Superior Institute will dissolve, but will continue as heretofore. After the business session a trip was made to Sunset Lake, where about 350 people were royally fed with clams, lobsters, fish, chicken, and corn. It was called a clam bake; however, the eastern men considered it a revelation, and came to the unanimous conclusion that Rhode Islanders had something to learn from Michiganders in this line. The Institute members were indebted to the Iron River Commercial Club for this entertainment and no greater compliment could be paid them than to have the epicure Parker, of Washington, throw up his hands and say: "Hold, McDuff, I've had enough," while the orchestra, concealed in the woods, played slow music.

On Thursday the members left Iron River for the Loretto mine where the course of the Sturgeon River was changed to permit mining to be carried on to better advantage. From this place automobiles conveyed the members to the Penn Iron Mining Co.'s hydroelectric power plant at Sturgeon Falls, and then to Vulcan, where lunch was served in the coaches. Automobiles then conveyed the visitors to Brier Hill, Chapin, and Pewabic mines. At Twin Falls the construction of a dam was in progress, and at the "C" Ludington shaft probably the largest of all Cornish pumps was inspected. This ended one of the most strenuous and enjoyable institute meetings ever held anywhere. The various committees who had charge of this meeting would have been congratulated publicly for the executive ability shown in so smoothly directing and caring for so large a crowd, but excellency is always modest and unfortunately no opportunity was found whereby the guests could express their appreciation of the kindnesses shown.

來 來

Personals

W. J. Murray, vice-president and general manager of the Victor American Fuel Co., left Denver in his car on September 7 for a month's vacation in California.

Dr. E. R. Buckley, past president of the American Mining Congress and state geologist of Missouri, has returned to Rolla after spending the summer at Jarbidge, Nev., in professional work.

Robert McAlister has resigned the superintendency of the Crested Butte, Colo., mines, of the Colorado Fuel and Iron Co. Mr. McAlister is mayor of his town and well and favorably known throughout his state as chief of the State Board of Examiners of coal mine inspectors.

The preliminary committee in charge of the entertainment of the American Institute of Mining Engineers, while in Los Angeles from October 5 to 8, consists of Seely W. Mudd, chairman, Theodore B. Comstock, secretary, W. H. Wiley, R. H. Simpson and Charles Colcock Jones. As there are 80 local members of the Institute in Los Angeles, this, combined with the well-known hospitality and attractiveness of the city, insures to the visitors a more than usually pleasant time.

W. Bert Lloyd, has resigned the superintendency of the Yankee Fuel Co., Yankee, N. Mex., to engage in business in Trinidad, Colo. His place will be filled by Mr. Jack Reese, until now, superintendent at Tercio, Colo.

John Dalzell, former State Commissioner of Mines of Colorado, is now manager of the Copeland Sampler at Cripple Creek.

J. E. Himes, manager, of the Talmage Mining Co., Goldfield, is in St. Louis. He expects to return shortly.

Eugene McAuliffe is appointed general coal agent of all Frisco lines, with office in St. Louis, and the office of the general fuel agent in Chicago is discontinued. In addition to the duties

heretofore performed by the general fuel agent for the operating and purchasing departments, he will assist the traffic department in the solicitation and handling of coal traffic.

Charles T. Van Winkle has resigned the position of superintendent of the Magna plant of the Utah Copper Co. and opened an office as mining engineer at Scott Building, Salt Lake City, Utah.

H. C. White, formerly secretary and sales manager of the J. Geo. Leyner Engineering Works Co., of Denver, Colo., has resigned.

R. B. Brinsmade has resigned as professor of mining engineering at West Virginia University and has accepted the position of superintendent of the Flojinales mines, Hidalgo, Mexico.

Arthur J. Hoskin, formerly professor of mining engineering at the Colorado School of Mines, Golden, after a summer spent at Alma in charge of the topographic work of the state geological survey, has opened an office for the practice of his profession at 308 Commonwealth Building, Denver.

H. H. Sanderson, of Danford & Sanderson, civil and mining engineers, Trinidad, Colo., has been for the past few months in Wyoming, Utah, and Nevada, in connection with the Draeger rescue apparatus for which his firm is western representative.

Morgan T. Townsend, well known to many of our subscribers as western circulation manager of MINES AND MINERALS is now representing the Stearns Roger Mfg. Co., at Leadville, Colo.

Percy E. Barbour, formerly of Salt Lake City, Utah, and more recently of Tecoma Nev., is now at Candor, N. C., in charge of gold-mining and milling operations.

Sumner S. Smith, engineer in charge of United States Bureau of Mines Rescue Car No. 4, with headquarters at Rock Springs, Wyo., has been in Alaska since July. He recently accompanied Secretary of the Interior Fisher and Dr. Jos. A. Holmes, Director of the Bureau of Mines, on a trip of inspection through the coal fields of that territory. Mr. Smith will remain in Alaska for some time.

Franklin B. Guiterman, Manager for Colorado of the American Smelting and Refining Co., is expected in Denver about October 1 from a three months' trip on the continent.

H. N. Spicer, Metallurgical Engineer, 333 Cooper Building, Denver, Colo., recently returned from Terry, S. Dak., where he has been making examinations and tests for Lundberg, Dorr & Wilson.

It is announced that Francis Church Wilson, Mining Engineer, of New York City, has been appointed assistant professor of mining at the University of Illinois, under Prof. H. H. Stock, former editor of MINES AND MINERALS.

J. C. Roberts, engineer in charge of United States Rescue Car No. 2, with headquarters at Trinidad, Colo., has been in Pittsburg, Pa., for some time where he will remain until about November 1. Upon his return it is intimated that Mr. Roberts' headquarters may be transferred to Denver.

Thomas C. Harvey, formerly of Forest City, Pa., and well known to the anthracite region of his state as captain for three successive years of the winning team in the first-aid contests, and at present foreman of United States Bureau of Mines Rescue Car No. 2, is in charge thereof while the car is laid up at headquarters in Trinidad, Colo. Mr. Harvey trained the local first-aid teams for the contest held in Trinidad on September 28.

George W. Evans, geologist, of Seattle, Wash., has accompanied Secretary Fisher on his personal tour of inspection through the Alaska coal fields. Mr. Evans, it will be remembered, mapped the Alaska fields and wrote the interesting articles on the Controller Bay Coal Field that appeared in Volume 30, MINES AND MINERALS.

Louis D. Huntton, for the past seven years professor of mining and metallurgy at the Sheffield Scientific School of Yale University, announces that he has opened offices at 42 Broadway, New York City, for the general practice of mining engineering.

M. Baumgartner, of Spokane, Wash., is managing properties in the Bay Creek district, near Wardner, Idaho.

M. Snellus, chief mine manager of the Blanchet-Gamatot Syndicate of Paris, has charge of the Elk City, Idaho, properties, recently purchased by the syndicate from John and Edward F. Massam, of Spokane.

Ralph D. Brown has been appointed Instructor in Civil Engineering at the Missouri School of Mines. Mr. Brown is a graduate of Miami University, and of the Civil Engineering Department of the University of Ohio. Since 1909 he has been in the employ of the O'Gara Coal Co., at Harrisburg, Ill., as assistant engineer.

Sidney S. Schmidt, a graduate of the Missouri School of Mines, and at present a chemist for the Washoe Smelter at Anaconda, Mont., has been appointed assistant in mineralogy at Northwestern University. He will take the place of A. J. Ellis who resigned to accept an appointment on the United States Geological Survey.

J. B. Tyrrell, mining engineer and geologist of Toronto, Can., has returned from a short visit to London, England.

J. A. Nolan has recently been appointed western sales agent of the Mining Safety Device Co., of Bowerston, Ohio.

Louis Bendit has been placed in charge of the Hope Engineering and Supply Co.'s western sales department with office in the New York Life Building, Kansas City, Mo.

John T. Abell is interested in the Stratford Development Co., recently incorporated with a capital of \$100,000 to handle mining lands in Mexico.

Frederic A. Potts has been able to leave the hospital in New York, where he was being treated for ptomaine poisoning. It was at first feared that he was suffering from appendicitis.

Governor Tener has appointed the following gentlemen as delegates from Pennsylvania to the fourteenth annual session of the American Mining Congress, at Chicago, October 24-28:

E. R. Pettibone, superintendent, Delaware & Hudson Co., Dorranceton; W. D. Owens, division superintendent, Lehigh Valley Coal Co., Pittston; Thomas Thomas, division superintendent, Lehigh Valley Coal Co., Wilkes-Barre; H. G. Davis, district superintendent, Delaware, Lackawanna & Western Railroad Co., Kingston; S. J. Jennings, inspector of Pennsylvania Coal Co., Pittston; C. F. Huber, vice-president and general manager, Lehigh and Wilkes-Barre Coal Co., Wilkes-Barre; Robert A. Quinn, manager, Susquehanna Coal Co., Wilkes-Barre; W. J. Richards, vice-president and general manager, Philadelphia & Reading Coal and Iron Co., Pottsville; W. H. Davis, superintendent, Coxe Brothers & Co., Hazleton; Jesse K. Johnston, general superintendent, Charleroi Coal Works, Charleroi; D. G. Jones, general manager, Pittsburg-Buffalo Co., Canonsburg; S. A. Scott, general superintendent, Monongahela River Consolidated Coal and Coke Co., Pittsburg; J. D. O'Neil, general superintendent, Merchants Coal Co., Pittsburg; A. W. Calloway, general superintendent, Rochester & Pittsburg Coal and Iron Co., Punxsutawney; A. D. Harmon, general superintendent, Keystone Coal and Coke Co., Greensburg; Harry Whyel, general superintendent, Whyel Coal Co., Uniontown; W. R. Calverley, general superintendent, Berwind-White Coal Mining Co., Windber; O. W. Kennedy, general superintendent, Orient Coke Co., Uniontown; Leslie H. Webb, 115 Chestnut St., Philadelphia; Frank H. Bailee, H. K. Porter Co., Pittsburg; Leo Gluck, Pittsburg Coal Co., Pittsburg.

A. W. Warwick, mining engineer, of Denver, and secretary of the Colorado chapter of the American Mining Congress, is in New York as representative of the Moore Filter Company.

Leroy A. Palmer, mining engineer of Salt Lake City, Utah, and well known to our readers, will be a resident of Denver after October first.

Charles A. Fuller, of Idaho Springs, Colo., who originally drove the Roosevelt Deep Drainage Tunnel, at Cripple Creek, Colo., has been placed in charge of the 1,500 foot extension thereof recently decided upon by the directors.

Mines *and* Minerals

Vol. XXXII—No. 4. SCRANTON, PA.—NOVEMBER, 1911—DENVER, COLO. Price, 25 Cents

PUBLISHED MONTHLY AT SCRANTON, PA.

ESTABLISHED 1881

WESTERN EDITORIAL OFFICE: 1221-1222 First Nat'l Bank Bldg., Denver, Colo.

CHICAGO OFFICE: 1006 Michigan Ave.

Entered at the Post Office at Scranton, Pa., as second-class matter

Address all business communications to MINES AND MINERALS, Scranton, Pa.

CABLE ADDRESS, "RETSOF, SCRANTON"

LONDON OFFICE: INTERNATIONAL BUILDINGS, KINGSWAY, LONDON, W. C.

SOUTH AFRICAN OFFICE: MANSION HOUSE CHAMBERS, ALDERLEY STREET, CAPE TOWN.

NEW ZEALAND OFFICE: 63 DIXON STREET, WELLINGTON.

AUSTRALASIAN OFFICE: 83 PITT STREET, SYDNEY.

SUBSCRIPTION RATES

Single Copies..... 25 cents

Yearly Subscriptions, including postage:

To United States, Mexico, Cuba, Porto Rico, Hawaii, and Philippines \$2.00

To Canada..... 2.50

To all other countries..... 3.00

The date after your name on the wrapper is that of the month to which your subscription has been paid. If you do not want to continue your subscription after that time, kindly notify us.

Notice to discontinue or change of address should be sent to the Scranton office.

When notifying us of a change of address always give your FORMER as well as your present address.

TABLE OF CONTENTS

EDITORIAL—

Mine Inspectors' Qualifications in England—Rational Sociology at Mines..... 193

COAL MINING AND PREPARATION

SAFETY THROUGH SYSTEMATIC TIMBERING, by Stephen L. Goodale..... 195

GENERAL HAULAGE OF COAL, by James Cameron..... 200

FIRST-AID CONTESTS EAST AND WEST..... 201

COAL MINING IN ARKANSAS, by Prof. A. A. Steel..... 205

ROPE SHEAVE FOR CURVES..... 207

TENTATIVE PLAN FOR SHAFT BOTTOM, by William B. Crawford..... 208

OUR COVER PICTURE..... 209

THE B. & K. COAL JIG, by N. R. Marvin..... 209

HEILWOOD, THE MODEL MINING TOWN..... 210

TRADE NOTICES..... 211

MINING SURVEY NOTES..... 213

COAL MINE SHAFT PILLARS..... 214

STEEL MINE TIMBERS AT DOOSON COLLIERY, by R. B. Woodworth..... 215

THE COST OF MINING IN IOWA, by Edward A. Sayre..... 216

STOCK PILE FIRES..... 217

INSTITUTE MEETINGS..... 217

COAL DUST, by James Ashworth..... 218

PERSONALS..... 219

APPOINTMENT OF H. M. INSPECTORS..... 220

CORRESPONDENCE—

Geometry—Watering Dust and Employment of Shot Firers..... 221

Arbitration in the Southwest—Watering Mines..... 221

CATALOGS RECEIVED..... 222

OBITUARY—

John Bond Atkinson..... 222

CENTRIFUGAL MINE VENTILATORS..... 223

BOOK REVIEW..... 224

EXAMINATION QUESTIONS—

Selected Questions From Illinois Examinations..... 225

ORE MINING AND METALLURGY

TREATMENT OF BROKEN HILL ORES, by W. Poole..... 227

SHAFT GATE, STRONG MINE, VICTOR, COLO..... 233

THE BURT REVOLVING FILTER..... 234

WHAT BRAZIL OFFERS PROSPECTORS, by George H. Mee..... 235

A SPANISH IRON-ORE TREATMENT PLANT..... 237

AIR-LIFT AGITATION OF SLIME PULP, by E. J. Laschinger..... 239

KEEPING TIME AT CRYSTAL FALLS, by James D. Vivian..... 241

MINES IN PIOCHE, NEVADA, DISTRICT, by R. M. Bell..... 243

SHAFT SINKING BY POETSCH METHOD..... 245

THE VOORSPOED DIAMOND MINE, by H. S. Harger..... 247

ANOTHER "CHICKEN BILL" YARN..... 248

BLAST-FURNACE SMELTING WITH OIL..... 249

THE NEW ELECTRIC HOISTS AT RAY, ARIZ..... 250

FIRES IN METAL MINES..... 253

TWENTIETH MEETING OF THE ELECTROCHEMICAL SOCIETY..... 254

A STANDARD BOILER HOUSE, by J. S. Jacka..... 255

SQUIBS—

A Woman Mine Worker, 204—Uses of Soapstone, 235—A Natural Salt Deposit, 238—Cherry Creek Source of Gold, 241—Norwegian Mineral Production, 244—Enforced Development of Mining Claims, 246—Barytes, An Important Mineral, 252—Oil in Trinidad..... 256

Mine Inspectors' Qualifications in England

ACCORDING to a recent decision by the Home Secretary of Great Britain, adopted evidently on the advice of the Civil Service Commission, the scheme of examination for Inspectors of Mines has been changed. In future, candidates must pass a written and oral examination in the elementary branches, also in coal, ore, and stone mining, in law relating to mines and quarries and also in electricity.

The examination is hedged in a way that precludes political or social influence aiding in the candidates' appointment, and further, the salary is an inducement to good men.

In the compensation of Mine Inspectors, Great Britain is pursuing a wise course. The man of proper character with sufficient ability and judgment to be an efficient mine inspector is naturally qualified for, and is likely to make, a first-class mine manager. By increasing the remuneration, the British government makes the salary of its inspectors equal to or greater than mine owners pay for the services of good men, and thus removes the liability of good inspectors resigning to accept better paying positions with corporations or extensive individual mine owners.

Another excellent feature of the British plan is that capable inspectors practically hold office during life or good behavior, and their tenure of office is not dependent on politics. This obviates frequent changes, which necessarily militate against efficient service. An inspection district naturally includes a number of collieries. If a mine owner hesitates to make changes in the management of one mine because a new man cannot produce best results until by months of experience he becomes familiar with the extensive workings and conditions therein, naturally a new mine inspector, having supervision of a number of mines, cannot become familiar with each one of them nearly as quickly, and as a result he cannot give as efficient service as one who is already familiar with them through several years' experience.

采采

Rational Sociology at Mines

FOR a number of years some mine owners and mine managers, imbued with a desire to improve the domestic conditions of their employes residing in the mine villages or "patches," have experimented on the lines of furnishing better houses with modern conveniences for the mine workers to live in. Others have gone further and encouraged social and athletic enterprises as well. These movements were always commend-

able in their inception, and though in some instances considerable expense was incurred, they seldom produced satisfactory results.

The substitution of labor from central and southern Europe for the former labor originating in northern and western Europe, filled the mining villages with populations almost entirely unfamiliar with the customs and habits of the former class of labor. The result was the unsanitary crowding of the houses, with consequent increased untidiness and the lack of cleanliness so essential to proper sanitation. The Slavs, Italians, and other races who had come from direst poverty and ignorance in their native lands, simply followed the habits and customs they had acquired from many generations. This was true of the masses. There were of course marked exceptions to the rule, but these were few.

Some mine managers when opening a new mine and erecting a new village went so far in their efforts to improve conditions as to pipe water into the houses, and put in bathrooms and water closets. In most of these cases, the tenants of the houses used the bath tubs as coal bins and the water closets as depositories for garbage. In course of a few months or a year, conditions in the model villages were not much better than before. The trouble was, not that the improved conditions were not necessary, it was because the people for whom they were intended were not educated up to and accustomed to them.

The H. C. Frick Coke Co. has gone about improving the sociological conditions of its employes in a rational manner, and is meeting with encouraging success.

Mr. Thos. Lynch, president, ably assisted by Mr. W. H. Clingerman, general superintendent, and the local superintendents are working on the following plan:

The miners' houses, which are ordinarily well-constructed frame buildings, are kept in excellent repair and are painted Indian red with white trim. These colors are selected because they have been found most durable in the coke regions, where the paint is subject to the action of the gases and soot in the smoke from the coke ovens. Water is either piped into the kitchens or is convenient to the back door. The streets of the mining villages are graded and drained with concrete gutters and terra-cotta drains. The sidewalks are graded and constructed so as to be mudless. Fences are straightened up and painted. Cesspools, that were formerly holes in the ground lined with plank, are made of concrete. Chicken coops and other outbuildings stuck together from old lumber and slabs by the workmen are being removed and replaced by structures erected of good lumber by competent carpenters. The villages are thus made neat, attractive, and clean. Care is taken by the officials to scatter through the villages families who are either naturally neat and cleanly, or who have learned to be so. Newcomers moving into the vacant houses are notified that they and their families must keep their houses and the surroundings as neat and clean as do their cleanly neighbors. A reg-

ularly appointed inspector is constantly on the job, and cleanliness and sanitation are enforced. In course of a comparatively short time the example of the more cleanly people has its effect, and a habit of domestic cleanliness is formed, and practically all take more or less pride in keeping things neat and clean.

To secure and encourage personal cleanliness the company is putting in free swimming pools at each of its villages. That at the Leisenring No. 1 plant was the first, and is typical of the others. It is pleasantly located within a stone's throw of one end of the village. It is rectangular in form, built of concrete, and is 80 feet long by 40 feet wide. It ranges in depth from 2½ feet at one end to 7 feet at the other. It is surrounded by a concrete walk on which are benches and all is enclosed by a neat and strong iron-pipe fence. Two bath houses with hot and cold shower baths are provided, one for males, the other for females. Each person using the pool is required to take a shower bath for cleansing purposes, then don a bathing suit, or trunks in the case of children when they can swim, and sport in the clean and frequently changed water of the pool. Back of the bath houses is located a dancing platform, which is available for use in summer for open-air dances or similar amusements. To aid in inculcating personal cleanliness, the two new public school houses at Leisenring No. 1 (and this may be the case in other localities) are equipped with bathrooms. Children who come to school in a dirty or filthy condition are not sent home, as was the case formerly. If old enough they are required to take a bath themselves. If very young, the teacher gives them the required bath, and they or their parents are notified that they must, in the future, be just as clean when they come to school. Already the compulsory bath is looked on by the school children as a disgrace, and as a result they are almost invariably neat and clean when they go to school. Thus, early in life they are acquiring habits of personal cleanliness.

By this rational system of gradually elevating the population and accustoming them to habits of cleanliness and sanitation, great results are being achieved, and the time is not far distant when the people who are being thus educated will fully appreciate bathtubs, bathroom accessories, and other conveniences and will use them as they should be used.

In addition to the foregoing provisions for the benefit of their employes, the H. C. Frick Coke Co. also encourages athletics among the young men, and each of its many plants has a baseball team, all of them being in a league with regularly scheduled games, and prizes are awarded the winning team.

While all that the H. C. Frick Coke Co. is doing may not be practical at other plants, part of the system can be advantageously adopted, and better results will be obtained than by trying to get people who are not educated up to them, to rationally use bathrooms and what are today necessities to Americans, but which in the not far distant past, were only luxuries.

COAL MINING AND PREPARATION

Safety Through Systematic Timbering

Method of Mining Used by the H. C. Frick Coke Co.
That Results in Safety and Economy

By Stephen L. Goodale*

More men are killed or hurt about the coal mines by falls of slate or coal than by any other one cause. To minimize this as far as possible the management of the H. C. Frick Coke Co. requires that posts shall be set in rooms and all working places with a short cap on top, as shown in Fig. 1, and at a distance apart not to exceed 4 feet 6 inches, whether the conditions seem to the miner to demand it or not; and where the roof seems according to the judgment of an experienced mine foreman, to demand more support, either a third piece, a cap spanning over the tops of two posts, is required, or the posts must be set closer than 4 feet 6 inches. This matter is not left to the judgment of the miner, who will almost always take greater or less chances in his mining, but is determined by competent officials of the mine, and the work is done under close supervision of these officials.

The scheme of mining somewhat resembles long-wall retreating in most of the mines at present. In opening a new property on this system, roadways would be driven to the boundaries of the property radiating from the landing at the bottom of the shaft until a sufficient number had been driven for the convenient working of the mine, these roadways constituting the main thoroughfares of the mine, and the number of them depending largely on the output desired. The location and manner of driving these roads, whether in triple or quadruple entry, will depend on engineering features at the individual properties. By triple entry is meant that there are three parallel main entries into the workings of the mine with two 60-foot pillars of coal separating them. In the quadruple system there are four such entries separated by three 60-foot pillars of coal. In the latter system two of these entries would be used for airways, one for a haulway, the other for a manway. The two outside entries would be used for ventilation. From these main roads another series of roads is driven 250 feet apart and called "butt" entries or headings, because they are driven on the butt cleats in the coal. These "butt" entries are usually driven parallel in pairs with the pillar of coal between—each entry being about 9 feet wide and the two entries are driven about 50 feet apart between centers. These butt entries, shown in Fig. 2, will be driven only in that portion of the mine from which it is intended to completely mine the coal without any long delays—when it is intended to work the mine on the retreating system, near the boundary of the property and remote from

the shaft. By means of the main thoroughfares, sometimes called "flats," and the butt entries leading from them, there are a series of working passageways to the various parts of the property which it is intended to mine first. Of course, a large amount of coal is obtained from this work of driving the various entries, and secured too at no great increase of expense over that from any other work; but it is all nevertheless the development work of the mine, although the real mining, by which the bulk of the coal is secured from the property is only ready to begin.

Next, rooms 12 feet wide, designated by numbers 1, 2, etc., in Fig. 2, are driven from the butt entries, beginning near the boundary of the property, and subsequent rooms are driven from points on the butts successively nearer the shaft, and from 40 to 80 feet apart, depending on conditions in different mines. The butt entries and rooms have blocked the section of coal to be removed into pillars or ribs, perhaps 240 feet long and of a width varying in different mines between 40 and 80 feet. Through each of these pillars there is also driven a breakthrough parallel to the butt entry and either 50, 100, or 150 feet from it. This is not shown in Fig. 2, but it is staggered in adjoining pillars to prevent a continuous line of weakness later in the mining. The breakthroughs are driven to assist ventilation and get air conveniently to the men working in the rooms—the course of the air-current at this stage of development being carefully directed so as to prevent gas accumulating in the workings. Fig. 3 shows a breakthrough where the coal has been mined from the rib on the left, and what coal is left in the center is merely to keep coal free from slate. The rooms may be, and

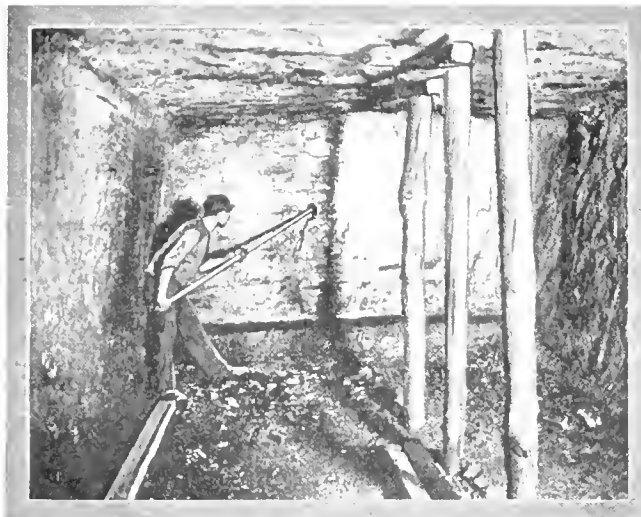

FIG. 1. TIMBER IN WORKING PLACE

often are, driven some considerable time before it is intended to completely clean out the coal in a certain section of the mine; but it is preferable to develop a section and then to go on at once and extract all the coal from a panel in a systematic manner. When this is done, the room roofs are not likely to fall in and necessitate the expense of handling rock and retimbering; besides, there are many air-courses which do not materially aid in ventilating the mine, but which, if not watched, might seriously interfere with the miner's safety. Room No. 1 would be driven first; before No. 1 is driven very far the second room is started, and so on, it being desired to have each room opened as soon as it is needed for a passageway in working the rib, but not too much before that. It is only necessary that room No. 4, for instance, be driven through to the "gob"—the mined-out and fallen-in section—by the time the first slice has been taken from the end of rib No. 3, and that room No. 3 should have been through by the time the first slice had been taken from the end of rib No. 2, in order that the ends of the ribs may be kept in the proper line.

Butt entries are driven first in that portion of the mine from which it is planned to completely mine the first coal, which would be near the boundary of the property and remote from

* Professor Mining and Metallurgy, University Pittsburg.

the shaft, when it is intended to work the mine on the retreating system. Generally the advancing and retreating systems of working are so combined as to meet to the best advantage the requirements of time of commencing production, the rate of production, and the continuance of a uniform rate throughout the life of the mine. When it is desired to begin producing at the regular rate very early in the development of the mine, butt entries are driven and a room and rib section started at any convenient place on the property, taking care, however, to leave ample pillars for the protection of the shaft and the main entries, and to so locate the section as to make convenient the later work when the surrounding coal will be mined. That is, in this case some sections would be taken on the advancing system. This will quickly provide rooms for a large number of men to work; and it is essential for the economical working of the mine throughout its life to plan so as always to have rooms for the necessary number of men to maintain production. The mine development and the advance system of mining are so planned as to avoid the necessity of maintaining at any time during the life of the mine very long roadways for only a small section of mining. Enough blocks of coal are left to be worked on the retreating system to maintain a reasonable proportion of production from any section of the mine somewhat proportionate to the length of roadway that must be maintained to get it out.

This combination of the advancing and retreating systems of working results in a better distribution of the capital cost of development than is secured when straight retreating work is carried on, and in a lesser late expense for maintenance of roadways than in the case in wholly advancing work, and thus means economical mining.

In addition to the above, certain local physical features must be considered, such as surface streams, topography, proximity of other workings, and anything else which may affect ventilation, drainage, or in any way the safety

and economy of mine working. For instance, at one mine the presence of a surface stream made it advisable to delay mining under the stream until as late as possible in the mine life to reduce pumping costs; and in the development of the other portion of the mine it happened that it was more convenient to carry on a part of the early development from an adjoining mine through an entry which was later sealed up when the development had reached the desired stage.

In the work of development, and up to the point of driving the rooms, the question of roof support is usually a comparatively simple one, because there are only narrow roadways driven through solid coal, the strength of which and of the rock above is usually such as to make necessary very little or no artificial support. At the main landings near the bottom of the shaft, steel mine supports may be used, or the roof may be arched with masonry or concrete, for these passages must be kept open long enough to make permanent supports advisable. In many of the manways and haulageways some timbering or support is necessary, but in general it is sufficient to keep loose rocks cleaned off, when the passage may assume a natural arch shape. Sometimes it is necessary to build a wall between two roads which approach each other at a sharp angle, and sometimes masonry pillars are built as supports for the steel beams used to make haulageways safe.

Having described the general plan of the mine, a more careful discussion of the "rib drawing" follows, to show the importance of systematic timbering. First, consider the order of mining in a block of coal some 250 feet by 1,000 feet, more or less, this block having been developed by the butt headings driven across it at 250-foot centers, the butts being reached from the shaft by the main entries or flats mentioned, and the rooms between the butts. The ribs are the sections of coal left between rooms, extending in length 250 feet between two butt headings, Fig. 2, and being in width from 30 up to 72 feet, it being from 42 to 84

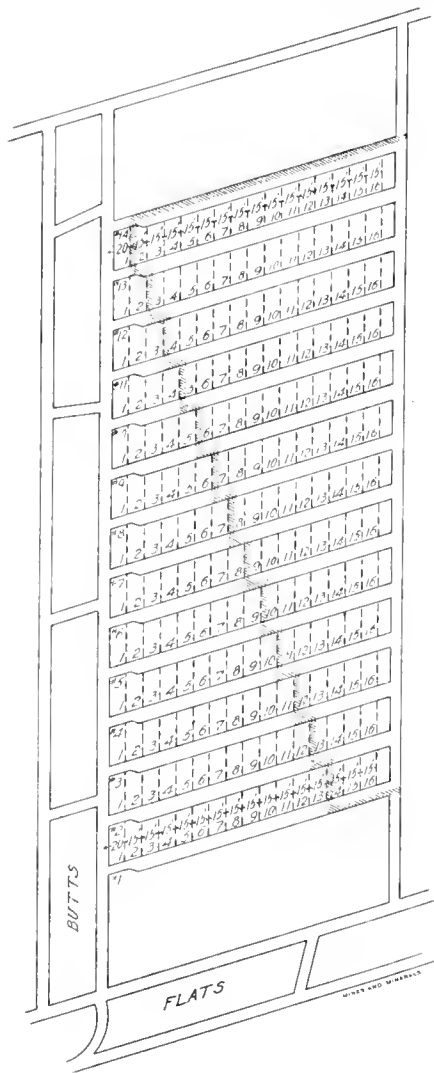

FIG. 2



FIG. 3. LOOKING FROM ROOM TOWARD THE GOB



FIG. 4. LAYING TRACK

feet between rooms, center to center. Each room is 12 feet wide and systematically timbered. Timbers or posts must be set as shown in Fig. 1, along the center of the room, and not more than 4 feet 6 inches apart, and kept up to within 6 feet of the face of the coal when mining by hand.

The method of working out the individual ribs is on a retreating order. Numbers are painted in white, on the rib of each room, starting with No. 1, 20 feet from center line of butt heading and each of the following numbers on 15-foot centers, to the end of each room. This system is to be strictly adhered to in all rib workings. The 15-foot steps, as shown in use at Continental No. 3 mine, where rooms are on 40-foot centers, will vary to meet the conditions at other mines, where different length of steps and room centers are used. Ribs thus marked will aid mine inspector, engineers, mine foreman, fire boss, rib men, etc., to determine the exact location of fracture lines without taking measurements. A 15-foot slice is taken from the end of rib No. 14, Fig. 2; next a second 15-foot slice, numbered 16, is taken from rib 14 and a first 15-foot slice from rib No. 13 at the same time. Next the third slice, numbered 15, from rib No. 14; the second slice, numbered 16, from rib No. 13, and the first slice from rib No. 12 at one time, and so on. Fig. 2 shows that the mining of all but one slice of rib No. 14 is completed, all but two slices of rib No. 13, and so on until from rib No. 2 have been taken only four slices—the mining being along a straight line on one side of which are the open rooms and from the other side of which the coal has been completely mined, as shown in Fig. 5.

The control of this line along which mining is conducted, which may be called the "line of fracture," is very important. It will not do to have one rib extended considerably beyond the line, nor can other ribs be permitted to be drawn before the proper time and so leave the line of fracture bowed in; for in either case the weight above is likely to squeeze down the promontory of coal

and cause it to be lost. The fracture line is about 22 degrees off the butts, which is about as small an angle as can be used and properly protect the men in this work. The use of a greater angle would require the opening up of too many rooms at one time, besides which the pressure would be more likely to cause squeezes. In order to keep the fracture line straight, without too much measuring, the sections are now regularly marked off with numbers on the sides of the rooms and the ribs also are numbered so that in the daily mining it is possible for foremen and others to check up the correctness of the fracture line without surveys. If the men in rib No. 14 are working on slice No. 2, those in rib 13 would be working on slice No. 3, in rib No. 12 on slice No. 4, and a simple inspection of these numbers will inform the foreman whether the men are working in the right places or not.

The method of working out the individual slices varies slightly in detail at different mines. At one mine, for instance, where the rib is 30 feet wide, as in Fig. 5, an 8-foot heading is driven across the rib from room to gob at right angles to the room and leaving a 9-foot stump of coal at the end of the rib. This heading must be posted with two rows of posts, one along each side, and the posts not more than 4 feet 6 inches apart. The track is laid from the room, as shown in Fig. 4, in through this heading as the work progresses. The illustration also shows 23, the marks left by the fire boss during his round of inspection. This 8-foot opening holes through to the gob at a point which was recently caved after the coal had been taken from work in the next rib. There is thus left the stump of coal with gob on two sides, and the miners take this out in two sections, first picking down and taking out that part farthest from their room and setting rows of posts, according to the regulations for systematic timbering given in Fig. 11. When this first section of coal is out the track is removed; extra posts are set as a breaking line, and the place is in the condition shown in

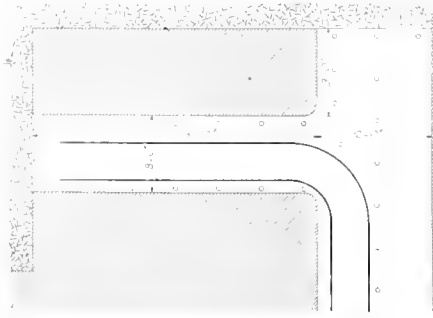

FIG. 5

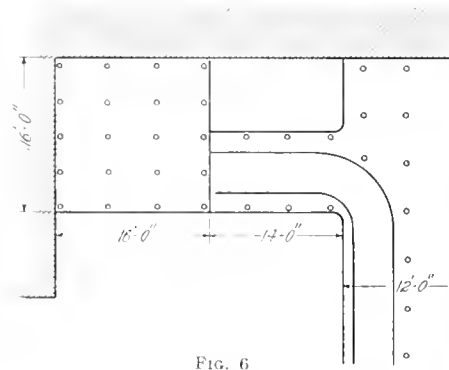

FIG. 6

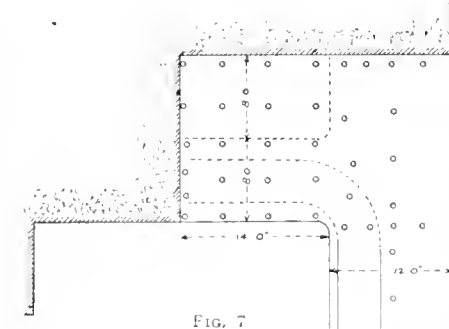

FIG. 7



FIG. 8. TIMBER READY TO BE DRAWN IN ROOMS



FIG. 9. REMOVING TIMBERS

Figs. 6 and 8. As many as possible of the posts in this 16 ft. 6 in. room next pulled by the chain and dog shown in Fig. 9, after which, sooner or later, the roof falls in, as shown in Fig. 10. Next the remaining half of the stump of coal is mined out, the track drawn back in to the room, and a section 16 ft. × 26 ft. is ready for the posts to be drawn and the roof caved in. Figs. 7 and 8 show the conditions just before the drawing of these timbers.

This work of rib drawing is dangerous. Great care and watchfulness must be observed, and long experience is necessary; therefore, the company requires either the rib boss or the fire boss to be present when a fall is made; i. e., while the timbers are being drawn after the mining of the coal from the end of the rib. The importance of systematic timbering is very great, because it is in the work of rib drawing that many are killed.

It may be well at this point to introduce some very excellent statements prepared by Mr. Austin King, Chief Mine Inspector of the H. C. Frick Coke Co., in regard to timbering, including his definition of systematic timbering, which he has kindly permitted the author to use.

PRESSURE AND PROPS

"The pressure exerted by the roof of a mine may be divided into two parts, which may be termed the major and minor pressure. The minor pressure is the pressure exerted by a few feet in thickness of the roof material or strata, which, in the coke region corresponds to, or consists of, the roof coal and shales up to that usually known as the "Checker," and varies from 5 to 7 feet in thickness, though more generally the latter.

"The major pressure is irresistible and is, roughly, about one and one-quarter times the thickness of the cover in feet, expressed in pounds per square inch. It is this pressure which splits up large pillars and causes "squeeze," or, where bottom yields easily, "creep," and sometimes both. It would be useless, therefore, to set props, no matter how strong, to resist it. It is possible, however, to provide props having such characteristics, and to vary the manner of setting them, so that, while supporting the maximum load permitted by the kind and quality of the timber in them, they will gradually yield to the major pressure and still retain their form and strength as props.

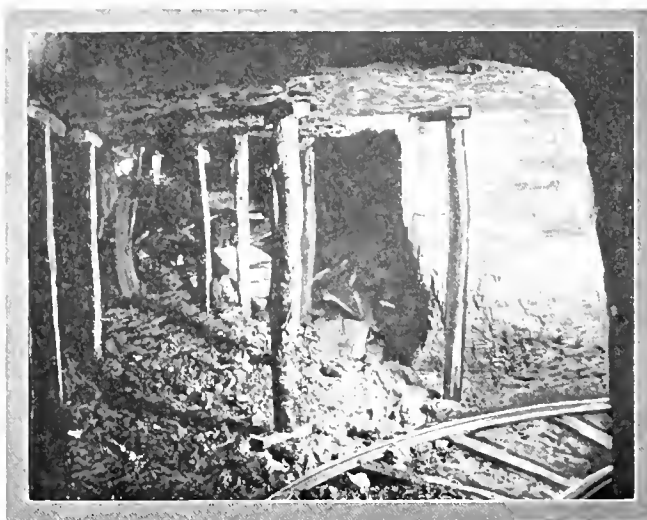

FIG. 10. EDGE OF FALL

elastic, they prove the safest and most serviceable. It may, therefore, be seen that a prop made from the hard woods might be more costly and at the same time less safe and serviceable. The perfectly rigid prop, as, for instance, a cast-iron one, such

"The quality so much desired in props is known as 'elasticity,' and we want enough of this quality to yield to the major, or entire, pressure and at the same time to be of sufficient strength to support the loosened pieces of roof immediately overhanging the excavated portion of the seam, giving a prop that will suffer the least damage from use under heavy pressure. Props of this kind are usually made from the softer woods, as fir, larch, and some pines. In these we have great elasticity rather than great strength.

"The most desirable props, then, are in this particular weaker than the rigid ones, because, while being somewhat as were used in mines 50 or more years ago, is not a suitable one. In it we have great strength but no elasticity, no brooming or curling up, and as the enormous pressure settles on it something must give way, and this something is always the rigid prop.

"The purpose in setting props, or, in fact, any other timber in mines, is to protect the workmen from injury from falling fragments of roof which have been loosened or broken by the pressure, or from a roof of loose or non-cohesive character, and to prevent the lower stratum of roof from falling when it is desired to keep it up while extracting coal or other minerals. When we fail to accomplish this purpose we must admit either the uselessness of setting props, or that an insufficient number were set. Another purpose of setting props is to resist the tendency of the roof and floor to approach each other and thus keep airways, waterways, or other roads open.

"Every prop should be set under a cap or cross-bar, and as safety depends so much on

them, we cannot be in the least niggardly or careless in their use. And when they are set in such a way that each will bear its full share of the load they are intended to support, it constitutes what is known as 'systematic timbering.'

"In order that props should give the best support, they should not deviate from a straight line more than $\frac{1}{4}$ inch to each foot in length, and the cap put on them should cover the top as completely as possible, so as to distribute the load over their surface to prevent them splitting.

H. C. FRICK COKE CO.

Regulations for Systematic Timbering

IN ROOMS exceeding 10 feet in width, posts must be set as near the center of the room as practicable, and the distance between centers must not exceed 4 ft. 6 inches. In rooms where coal is mined by hand, the distance between the last post and the face must not exceed 6 ft. In rooms undercut by machine the distance between the last post and the face shall be such as, in the opinion of the Mine Foreman and the Mine Inspector, affords the best protection for the workmen.

IN ALL RIB OR PILLAR DRAWING, where the coal can be reached without additional track, a line of posts not exceeding 4 ft. 6 inches between centers must be set in the working places, and when widening out, other posts not exceeding 4 ft. 6 inches between centers must be set parallel, and at right angles, to the first line. In rib or pillar drawing, where additional track must be laid when cutting over near the end of the rib or pillar, posts not exceeding 4 ft. 6 inches between centers must be set in line on both sides of the opening; and in the following named mines, CROSS BARS or collars must be set over them. The idea of setting these cross bars across the track, where the roof is comparatively good, is that they may give warning, by their condition, of any unusual condition in the roof, as the presence of smooth slips or great weight; therefore, where the roof is usually of good character, they may be of lighter weight than where bad or dangerous conditions are known to exist.

In all mines, when the GOB is reached, a line of posts shall be set around its edge; the distance between such posts, or between the post and coal, must not exceed 4 ft. 6 inches between centers.

In order to carry out the above regulations, it is necessary that rooms be kept in line with the sights set by the Engineers.

The Mine Foreman and his assistants must see that more posts than those required in the foregoing rules are set, if in their opinion, the conditions of the working places demand them.

These regulations are issued with a view of reducing the number of accidents from falls of roofs and sides; and the exercise of the best of judgment and the maintenance of STRICT DISCIPLINE are necessary in order to obtain the maximum amount of benefit from their enforcement.

FIG. 11

"The stronger the roof is, the stronger the props required, because the roof, if broken, is in much larger pieces; conversely, where the roof is broken and tender, the props set must be more numerous, and if these required are set so thick as to interfere with the carrying on of the work, or the ventilation, cross-bar sets with lattice-work lagging must be substituted.

"Where there is a strong roof and bottom, the props should be set so as to permit the roof to ease, or gradually settle down, or the bottom to heave, and thus prevent the breaking of the prop or prolong its usefulness as such. Under such conditions they should not be driven very tight, and in such cases caps of

long, the crushing weight would be $63,600 \div 8$, or about 8,000 pounds., or the weight of a section of roof of average material covering about $12\frac{1}{2}$ square feet, or a space of about 3 ft. X 4 ft. in area, which would be supported by a chestnut prop if the roof were loose for 5 feet above the cap piece."

Special attention should be paid to the above definition of systematic timbering, "the setting of props in such a way that each will bear its full share of the load they are intended to support."

The H. C. Frick Coke Co., which operates its mines and coke ovens on the policy that "safety is the first consideration,"

H. C. FRICK COKE CO.

DAILY REPORT OF RIB FALLS, CONTINENTAL NO. 7 MINE

MARCH 27, 1911

Section	Heading	Rib No.	Check Nos.	Fire Boss in Charge	Fall Made in Presence of	POSTS			Inches Coal in Roof	CONDITION AND REMARKS	
						Set	Drawn	Lost			
South E.	3 Butt.	4	19	Nick	Jno. Smith	20	12	8	6	Bad roof (down). Fall good.	
South E.	4 Butt.	5	180	Barthon	Jno. Smith	16	13	3	6	Bad roof (down). Fall good.	
South E.	5 Butt.	23	123	Barthon	Jno. Smith	10	10	0	6	Good roof (down). Fall good.	
										Done at 5 P. M.	
Total						46	35	11			

SAFETY THE FIRST CONSIDERATION

JAMES MOORE, Mine Foreman.

FIG. 12

soft timber should be used, otherwise the invariable result is at first a bent, and later on a broken and useless prop. To accomplish and extend the same purpose, 'tapered' props have been introduced which have given great satisfaction, both from a safe and economic standpoint. The face of the tapered end is usually about 3 inches in diameter and is about one-fourth of the area or section of the body of the prop. An eminent colliery manager, in charge where these have been used exclusively for years, said recently: 'I find that the increased usage of timber, caused by the laws requiring systematic timbering, has been nearly counterbalanced by the longer life of tapered props.'

"Other things being equal, the strength of a prop varies directly as the square of the diameter, and inversely as the length. The ratio of the diameter to the length of the prop, in order to have equal power of resisting compression and deflection, is 1 to 12. However, if by reason of physical defects, such as knots, splits, worm holes, or disease, the wood is weaker, the diameter of the post should be increased.

"The crushing strength of timber usually furnished in mine props is as follows: Hickory, 9,500 pounds per square inch; black oak, 7,300 pounds per square inch; red oak, 7,200 pounds per square inch; chestnut, 5,300 pounds per square inch.

"Taking chestnut as having the average strength, and allowing 75 per cent. of the material, or 12 square inches in a prop of that wood, to be sound and straight in fiber, it would require a total pressure of $5,300 \times 12$, or 63,600 pounds, to crush it. Since, however, the prop is 8 feet

has adopted, printed, and distributed the "Regulations for Systematic Timbering," shown in Fig. 11.

In order that the manager and engineers may follow the progress of mining and pillar drawing, a daily report of the work done is placed on the form Fig. 12 and signed by the mine foreman. The report covers the mine section, number of butt entry, number of rib or room pillar, number of slice as marked off in Fig. 2, or check number, the name of the fire boss in charge of this section in the mine, the name of the rib boss who has charge of pillar-drawing operations; number of posts set to support the roof while drawing the pillar; the number of posts drawn and recovered; the number of props lost; the number of inches of coal left in this part of the mine to support the roof; and the condition of the room, with remarks. The form is reproduced in Fig. 12, with the remarks printed in as received in the office. The foreman finds stamped on the blank report furnished him the phrase "Safety the First Consideration," which at once calls his attention to the company's desire to protect its miners in every possible way. From the report it will be seen that in this matter of systematic mining and timbering the loss

of timber is not nearly so great as where props are left standing indefinitely in a room. When 76 per cent. of the props stood in robbing pillars are recovered the rib boss is doing good work.

Certain details of this work naturally differ, according to local roof and floor and pressure conditions in the mines. Where the roof pressures are heavy the ribs are wider, that is, the rooms are driven at perhaps 84-foot centers. At the Continental No. 3 the

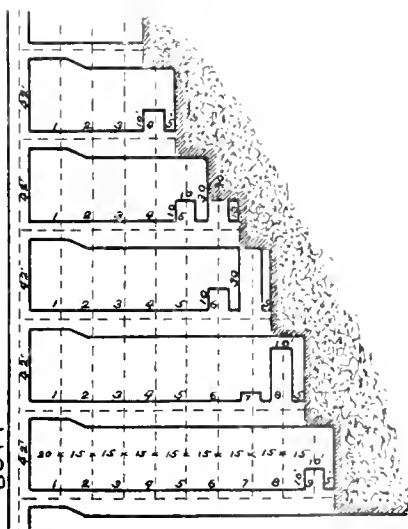

FIG. 13

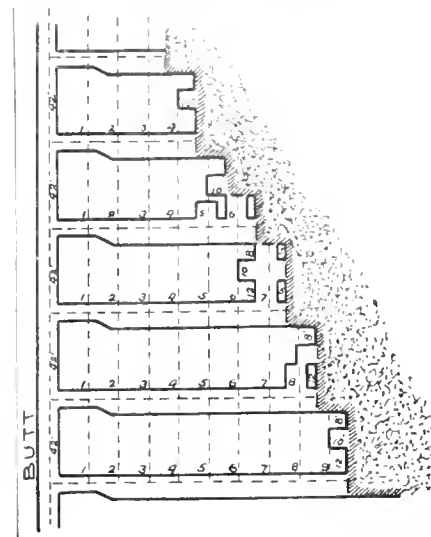

FIG. 14

detail order of work at the end of the ribs is slightly different, as shown in Figs. 13 and 14. At this mine the coal is hard and the bottom soft.

The purpose of the present paper is to call attention to the safety of the miners, which is insured as far as possible in this work by requiring the regular timbering, not leaving the amount of the timbering optional with the miner. A very important matter in addition to this, however, is the large recovery of coal made in mining on this plan. The recovery is said to average about 90 per cent., and in some cases to reach 93 or 94 per cent., depending on conditions, particularly the quality of coal near the floor and roof, and the character of roof and floor at any point. The present recovery of coal depends also on the thickness of the seam being worked, for 3 inches of coal left in the roof of a 5-foot seam will be a larger per cent. of the total coal than 3 inches left in the roof of a 9-foot seam. A layer of coal may sometimes be left on the roof if the roof coal is of a poor grade, high in sulphur or phosphorus, but usually in this district only to protect the mines because the coal withstands the action of the air better than the slate.

Systematic timbering in itself is a comparatively simple matter easily explained; but there is required for an adequate understanding of its importance a knowledge of many complex conditions. The present paper is an attempt to describe sufficient of these conditions and the system of mining employed by the H. C. Frick Coke Co. to make clear the importance of what this company has done in this line toward promoting the safety of their miners. Strangely enough one of the greatest obstacles met with in this work is the enforcing of the regulations, that is, securing officials for the mines who will themselves follow closely the regulations and enforce their observance by others under their authority. Strict discipline is the only means of securing the proper observance of the regulations, and is the means employed. Finally, it may be said the motto "Safety the First Consideration" applies to the mining of the coal and systematic timbering of the working places in the most remote sections of the Frick mines, as well as the more conspicuous portions of the plant above ground.

采 采

General Haulage of Coal

The following paper was read at the monthly meeting of the employes of the Victor-American Fuel Co., by James Cameron, Superintendent:

The question of hauling is one of the most important factors to be considered; it plays a part in nearly everything around the mine, from the boiler house to the face of the workings, whether it is rope, electric, or mule haulage, or all three of them.

The first thing to be considered is the boilers; they must be kept in good shape so they can produce at all times enough steam to run the engines and generators without being pressed too hard.

It is essential at all times that a good head of steam be kept up, but not blowing off; to insure this, competent firemen are necessary; men who will look after the boilers and furnaces and use the strictest economy with both fuel and water, and at all times be on the lookout for leaks, both in the steam and water lines, as nothing wastes money faster than steam leaking from joints or water running away from poorly packed pumps and valves.

In the power house, where high-speed engines and generators are running every hour of the day and night, it is an important factor in the question of hauling to have a careful, sober, and steady man to be in charge; a man who is not rattle-headed, but a man with a cool head and a good disposition; if he is not so, he can be the cause of losing lots of time during the day's work; for instance, if the motors happen to be pulling all at

the same time on a very hard pull, overloading the generators and throwing the circuit breaker; if the engineer is not alert he can be the cause of losing much time by being slow in putting the circuit breaker back in place. Should this happen several times a day it can readily be seen it will cause the loss of output of many tons of coal in the day's run which would be avoided by having a careful and steady man.

The hoisting engineer, the man who stands on his feet all day long waiting for the signal to go ahead or back up, as the case may be, also can cause many delays during the working day if not careful, steady, and quick in action, both in starting as well as stopping trips, and it stands this man in great need to keep his temper when a trip is off the track; many engineers get hot when trips are off the track and lose their heads, thus causing unnecessary delays.

Before entering the mine there is one more important matter, and that is the stable where the mules are kept and the care they get. It is important that mules have the best of care and be fed at the proper time; they should be fed in the morning at least 2 hours before going into the mine. I have never had the experience of water being kept in front of the mules in the stable, but it strikes me as being a very good thing, for if the mules coming out of the mine sweating, more especially on a cold frosty night, they may not feel like drinking, but after they have been in the stable a little while they may then feel like drinking and it is there for them. Here is a place, like the boiler house, where a careful, watchful man can save many dollars by being careful with the feed. Not that he is to starve the mules, but he should give them enough to eat and see that none is wasted; it is the amount that is wasted that raises the price of feed per head above what it ought to be. The stable boss also should render all the assistance he can toward getting everything ready in the line of repairs to harness, seeing that the mules that have lost shoes during the day's work have been replaced; this should be done in conjunction with the drivers and the driver boss; if there is not a driver boss, the mine boss should assume the responsibility.

The next important thing is getting the mules and drivers out of the stable in the morning on time. A quick, prompt start in the morning with everybody on hand is essential to a good day's run. After they are started from the stable get them into the mine to their working places as quick as possible and keep them busy until dinner time. The men in charge should be around the partings about this time and see that the drivers do not stop too soon for dinner; much time can be lost at this stage of the game if the men in charge do not attend to this. They should also be on the partings at starting time after dinner to see that the drivers start promptly and are kept busy until quitting time. These points should be watched closely, for many tons of output can be lost at these stages.

Another thing to be considered is the convenience of partings in the mine. The more convenient the partings are to the working places the more coal can be pulled per driver, and consequently the price of hauling decreases. It is not a good thing to have too many drivers coming into one parting unless the parting and the hauling roads to it are so arranged that no more than two drivers be on the one road at the same time.

In a mine where motor haulage is used, it is important that the motors be kept in first-class shape, also the trolley, and feed-lines, and the bonding; the pit cars should also be in the best condition to insure perfect hauling. A great deal depends on the motorman for success. A good man, one who can do slight repairs if anything should happen to his motor during working hours, saves a great deal of lost time.

One of the last and most important parts to be taken into consideration is the maintenance of the tracks; this is the most essential part to be played; the better the tracks are kept the more success in hauling coal.

First-Aid Contests East and West

Rocky Mountain District, at Trinidad, Colo. Anthracite, at Shamokin and at Inkerman, Pa.

The first annual Helmet and First-Aid Contest of the Rocky Mountain District, which took place on the grounds of the Las Animas County (Colo.) Fair Association, at Trinidad, was in many ways an event of importance. First-aid work in Colorado dates from the arrival of the United States Bureau of Mines rescue cars, early in November of last year; however the training officially given the miners probably does not cover a longer period than 6 months, yet with this limited instruction the Bureau turned out 17 first-aid and 8 helmet teams. It is largely due to the hard work of the men, to cordial cooperation on the part of the producing companies, to regular instruction by the companies' physicians, and those in charge of the instruction cars of the larger companies, to the enthusiasm of J. C. Roberts, engineer in charge of the Bureau of Mines Car No. 2, and above all to the skill, long experience and infinite patience of Thos. C. Harvey, foreman of Car No. 2, that the meeting was such an unqualified success and that the teams were so evenly matched that the judges were able only after long deliberation to justly award the prizes.

There was a first-aid contest participated in simultaneously by the 17 first-aid teams, and a helmet contest in which each of the 8 teams in this class worked singly.

The four events in the first-aid contest were as follows:

1. One-man team: Man's left hand mashed, bones crushed, and cut in palm of right hand. Dress with first-aid packet.

2. Two-man team: Man lying on live wire. Burned on back. Treat.

3. Four-man team: Fracture of spine in middle of back. Treat and carry patient 50 feet.

4. Full team: Man injured by premature blast. Face burned, right arm broken between wrist and elbow, simple fracture. Left thigh broken between hip and knee, compound fracture with profuse bleeding. Properly care for injuries and transport 50 feet.

After all the teams announced their readiness for inspection, the judges, consisting of Drs. M. W. Glasgow, of the American Red Cross car, and D. G. Thompson and G. W. Robinson, of Trinidad, entered the demerits on their respective records, and another event was started. At the outset each team was given a credit of 100 points in each event, or a total credit of 400 for the contest. After deducting all the demerits from the total credit of 400, a division by four gave the final percentage of the team. It is a pleasure to note that with the exception of three teams the final percentages were all above 90 and that with the leaders the differences were but a fraction of 1 per cent.

The first prize, a silver cup, given by subscription, was awarded the Primero, Colo., team, captained by Bert Pollard, with C. D. McGinnis, Frank Urfer, Joe Boyd, Robert Scott, J. Lukenbaugh, and Geo. Fortune as a crew.

The second prize, a surgeon's first-aid emergency chest,

also given by subscription, was won by the Starkville, Colo., team, captained by B. Hanley, and composed of A. Dennison, J. Marzer, Geo. Charters, H. McDougal, and J. Olson.

Judging was rendered difficult by the nearly equal skill and ability of the competing teams and by lack of judges, of which only three were available. Another time the suggestion of having a judge for not more than three teams and who shall decide on the merits of different teams in each event (to eliminate the "personal equation" and to prevent any possible charge of favoritism) will probably be adopted. It was impossible for three judges to cover the entire work of the 17 teams in an absolutely thorough manner and perhaps many good points were missed, but, on the other hand, as many demerits were probably overlooked, so that the outcome would have been the same. The perfect team work and ability to do the right thing at the right time certainly qualified the Primero team for first place, regardless of the many novel features used by them in the way of improvised splints and bandages and the device of Dr. W. V. Gage, of affixing a tin-covered first-aid package to the side of the dinner buckets.

All the teams had high ratings in the first and third events, but in the second, had the work been actual instead of imaginary, most of the teams would have been subjects for first-aid work themselves. In this event but three teams remembered either to insulate themselves or to short-circuit the imaginary live wire before proceeding to handle the patient, and the winning team was one of these three. In this same event 10 teams failed to draw out the tongue of the patient, and the winning team was one of the seven which did.

In the fourth event the common failures were, leaving underclothes over the wound (four), failure to treat for shock (three), poorly applied splints (three), and failure to treat for compound fracture (three).

The Thos. C. Harvey splint for broken back, and the method of using lighted safety lamps for

warming a patient (where warmth was necessary) and also devised by Mr. Harvey, were used, one or the other, by all the teams. In the first aid-events, too much praise cannot be given to the "patients" whose endurance under rather painful surroundings was of most material assistance to all the teams.

The helmet events took place in a specially-constructed building filled with sulphur fumes. The work was double and consisted in

1. Entering the mine with a full team and carrying a roll of brattice cloth across an overcast and back again to daylight.

2. Reentering the mine, finding an unconscious man, bringing to daylight across the overcast and applying the customary means of resuscitation,

The judges in this event were H. H. Sanderson, mining engineer, of Trinidad, Thos. C. Harvey, and W. D. Scofield, the first-aid miner of the Bureau of Mines car, No. 2. The system of demerits employed was the same as in the first-aid events and resulted in awarding the first prize, a silver cup given by subscription, to the Morley, Colo., team, composed of J. C. Davidson, captain, Ernest Reich, Thos. Warrick, Joe Bell,

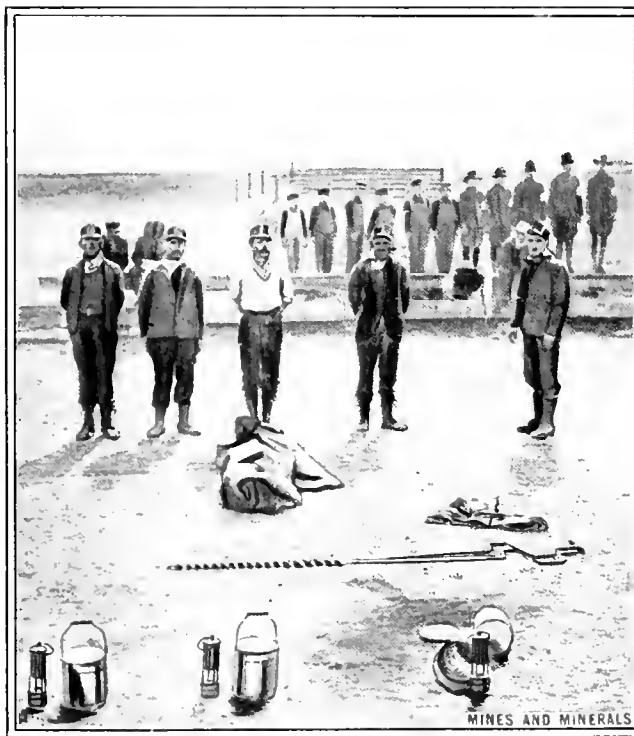

FIG. 1. PRIMERO, COLO., FIRST-AID TEAM, 1ST PRIZE



FIG. 2. VIEW OF FIELD AT SHAMOKIN.

Joe Mutz, Joe Woznica, and E. F. Gaines. The second prize, a Draeger half-hour oxygen apparatus, presented by Messrs. Danford & Sanderson, of Trinidad, was awarded to the Hastings, Colo., team, D. H. Reese, captain, A. E. Thompson, H. A. Winters, E. Spencer, and P. Francescone.

The Morley team did magnificent work and the absolute control of their captain and the implicit obedience of the men illustrate two of the most important, if not the most important, factors in actual rescue work. Strange to say all the teams were demerited for failure to use a life line and for failure to properly test for gas.

One of the most interesting events of the entire program was the first-aid contest between the boys of the Sopris public school and the Boy Scouts of the same place, who went through practically the same series of tests as did the elder relatives, of many of them in the regular series. After a severe struggle the first prize, a silver cup, given by Dr. T. J. Forhan, went to the Sopris School boys, captained by James Stratton, with Tom Hill, George Allen, Charles Costa, James Viccello, and Francis Burns as the corps. Teams from Dawson Loretta, and Koehler, N. Mex., and one team from Somerset, on the "western slope," came a long distance with their apparatus to enter a contest under unfamiliar surroundings.

The presidents of two of the largest companies were at the field and practically every superintendent and foreman in the district was on hand to encourage his teams. The attendance from among the miners was large and many brought their families for the day. James Dalrymple, chief inspector of coal mines and his three deputies, Messrs. Oberding, Douthwaite, and King, were on hand, and there were representatives from coal companies in Utah, New Mexico, and Wyoming, which did not enter teams but which sent official representatives to study the work.

The commissioner of mines (metal) for the state, Thomas

R. Henehan, and three deputies, Messrs. John R. Curley, of Leadville, W. H. Paranteau, of Central City, and Samuel Treais, of Montrose, were also present. It is a fact, perhaps not generally recognized, that the percentage of fatal and non-fatal accidents is greater among metal than among coal miners and it is a matter of congratulation that the commissioner of mines was able to see what the coal miners could do, to the end that those with which his department is concerned in the metal mining districts may be encouraged to take the same steps for the relief of suffering and the rescue of those overtaken by accident.

In every way the meeting was a success, and to Messrs. J. V. Thompson, William McDermott, Mark O. Danford, and H. H. Sanderson, the committee on arrangements, much praise is due.

來 來

Glen Lyon's First-Aid Victory

The second annual first-aid contest between the employes of Susquehanna Coal Co., Mineral Railroad and Mining Co., Summit Branch Mining and Lytle Coal Co., was held September 16, at Edgewood Park, Shamokin, Pa.

Invitations to this meet were sent by Robert A. Quin, general manager of these companies to officials of the other anthracite collieries, a large number of whom were in attendance, besides about 1,000 others. This being an annual event, it is made a holiday in which President Morris Williams, Vice-President George H. Ross, and General Manager Quin, act as hosts. The other officials also assist in the entertainment and all are to be congratulated on the happy and smooth way in which so large an affair was conducted. Dr. F. L. McKee acted as announcer of events, Gen. C. B. Dougherty, assistant general manager, as master of ceremonies, and Chas. K. Gloman, secretary.

Division superintendent of the Susquehanna Coal Co.



FIG. 3. MORLEY, COLO., HELMET TEAM, 1ST PRIZE



FIG. 3. 41 FIRST-AID TEAMS CONTESTED

entered 11 teams that had been trained by Doctor McKee, Division superintendent of the Mineral Railroad and Mining Co. entered 20 teams, trained by Dr. J. M. Maurer

The doctors were also interested in this event from the fact that the surgeon who trained the team that won the full corps event was to receive a silver medal. The judges for the

FIRST-AID CORPS, COAL COMPANIES

Colliery	Judges' Score of				Event. (Deductions from 100.)				Final Contest. Problem No.	
	Granny Knot 1	Wrong Dressing 3	Hemorrhage Control 10	No Gauze 5	No Splint 5	No Stimulation 5	Time Limit 1.1 Min.	Unfinished Dressing	Total	Time Consumed
1										
2										

FIG. 4

FIRST-AID CORPS COAL COMPANIES FINAL SCHEDULE OF SCORES

Number Colliery	One Man	Two Men	Three Men	Full Team	Total

FIG. 5

Division superintendent of the Summit Branch Mining Co., Wm. Anman, entered 6 teams, trained by Dr. G. M. Stites.

Lytle Coal Co., D. V. Randall, superintendent, entered 2 teams, trained by Dr. B. C. Guildin.

Susquehanna Coal Co., Shaft P. O., E. A. Van Horn, superintendent, entered 2 teams, trained by Doctor Mauer.

In all there were 41 teams, which, with the subjects, made a total of 264 men engaged in the elimination contests in the forenoon. After lunch, in which 800 guests took part, 27 teams contested for prizes and a trip to the first-aid meet at Pittsburgh, October 30.

occasion were Major Ralph W. Montelius, Surgeon 4th Brigade, N. G. P., Major W. Clive Smith, Surgeon 9th Regiment, N. G. P., and Captain J. C. Biddle, Assistant Surgeon, 8th Regiment, N. G. P.

The winners in the final events were:

One-man event: Lytle, inside.—Matthew Kaufman; James F. Simons, subject. Prize, French Bronze medals.

Two-man event: Glen Lyon No. 6, outside.—Elias Negosh, captain; Frank Bonsock; Andrew Barron, subject. Prize, French Bronze medals.

Three-man event: Glen Lyon No. 6, No. 7 shaft.—James Mulhern, captain; Anthony Dougherty; Costic Terkowski; Andrew, Seletski, subject. Prize, French Bronze medals.

Full-team event: Glen Lyon No. 6, outside.—James Sack, captain; Frank Bonsock; Stanley Prush; George Perkins; Elias Negosh; Andrew Barron, subject. Prizes, Silver Cup, Gold Bronze medals and trip to Pittsburgh, October 30.

Dr. F. L. McKee won the silver medal.

As the ground was damp and soggy from rain the night

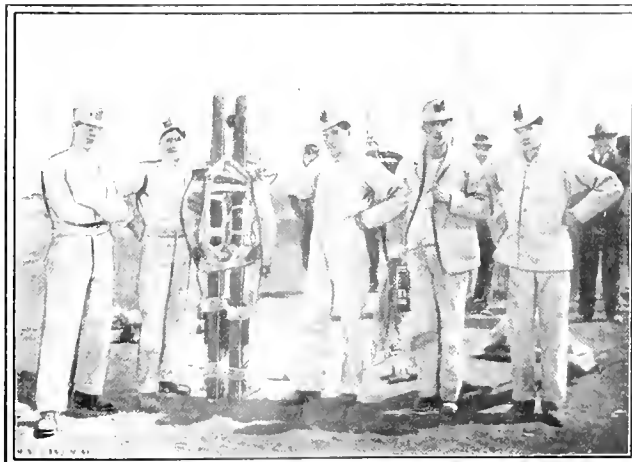

FIG. 6. STARVILLE, COLO., FIRST-AID TEAM, FIRST PRIZE

be on canvas was put down for the teams to work on. Through the kindness of Manager Quin, MINES AND MINERALS is able to furnish score cards used at this meet which was the largest so far has taken place in this country. Fig. 4 is the form used by the judges in the elimination and final contests. Fig. 5 is the form used in scoring time and in final schedule of scorers.

After the judges determine the points they are transferred to the final schedule, Fig. 5, which is also the time sheet for score of events.

A view of the field during the contest is shown in Fig. 2

采 采

Inter-Company First-Aid Contest

The third annual contest between the first-aid teams of the mining companies of the northern part of the Pennsylvania anthracite region was held at Valley View Park, Pa., on September 16.

Nearly all the companies of this region have held contests among the first-aid teams of their own mines and the winners of these were entered in this inter-company contest, which was under the auspices of the American Red Cross. Sixteen teams were entered as follows:

Delaware, Lackawanna & Western Railroad Co.: Bellevue, John M. Jones, captain; Sloan, William King, captain; Brisbin, John Price, captain; Woodward, Benjamin Lewis, captain.

Lehigh Valley Coal Co.: Pittston, James Clark, captain; Prospect Colliery, George Hileman, captain; Centralia, Harper Minnick, captain; Hazleton, Earnest Crabtree, captain.

Scranton Coal Co.: Pine Brook, Arthur Young, captain.

Hillside Coal and Iron Co.: No. 5, Dunmore, Fred Campbell, captain; South Pittston, James Pollard, captain; Mayfield, Michael Roberts, captain.

Pennsylvania Coal Co.: Law Shaft, Wilham Creedon, captain.

Forty Fort Coal Co.: Isador Hochritter, captain.

Parrish Coal Co.: Parrish and Buttonwood Collieries, Thomas Maggs, captain.

Price-Pancoast Coal Co.: Thomas Cook, captain.

The Board of Managers were: Dr. M. J. Shields, field representative of American Red Cross, N. J. Coughlin, C. E. Tobey, Frederick Chase, Dr. D. H. Lake, Dr. F. F. Arndt, Dr. J. V. Birtley, Charles Enzian, of United States Bureau of Mines, Col. R. A. Phillips, W. P. Jennings, Atherton Bowen, Doctor Walter Lathrop, Dr. J. F. Jacobs, James McCarty.

The secretaries were: R. I. Vail and W. H. Charles.

The judges were: Major Charles Lynch, U. S. A., Major J. H. Allen, U. S. A., and Capt. A. W. Williams, U. S. A.

The contest consisted of five events as follows:

First event, one man contest. Fracture of bones of nose with severe bleeding, caused by

the kick of a mule. Stop bleeding and dress with first-aid packet.

Second event. Explosion of keg of powder, severe burns of face, hands, and front of chest. Dress.

Third event. Three-man contest. Man lying on live wire, remove and treat.

Fourth event. Right collar bone broken, left foot badly crushed, but not bleeding severely. Dress.

Fifth event, general team contest. Man unconscious and suffering severely from shock. Wounds, right hand smashed with cuts in palm bleeding freely, severe scalp wound with hemorrhage from artery, simple fracture upper third left thigh. Treat and dress.

The first event was won by the Brisbin team of the Delaware, Lackawanna & Western Co.; the second by the Law Shaft team of the Pennsylvania Coal Co.; the third by the team of the Forty Fort Coal Co.; the fourth by the Hazleton team of the Lehigh Valley Coal Co.; the fifth, which was the general contest for the Muckle Cup, was won by the Brisbin team of the Delaware, Lackawanna & Western Co., second place being taken by the Centralia team of the Lehigh Valley Coal Co., and third by the Mayfield team of the Hillside Coal and Iron Co.

A bronze medal of the American Red Cross, a photograph of which is shown in Fig. 1, was given to the winners in each of the first four events.

The prize for the fifth contest was the silver cup, Fig. 2, which was presented in 1909, by Mrs. Muckle, of Philadelphia, to be contested for and to become the property of the winner able to hold it in three successive contests. This was the third annual contest for this prize, the winners up to

the present being: Avoca team of Pennsylvania Coal Co., in 1909; Woodward team of the Delaware, Lackawanna & Western Co., in 1910; and Brisbin team in the present 1911 contest. Also a bronze medal was awarded to each member of the winning team. The Brisbin team and the Woodward team were both sent to the first-aid meet at Pittsburg.

采 采

A Woman Mine Worker

In the Derby, England, *Mercury*, of September 22, is an account of the death, at Brynna, in the Wigan coal field, of Kitty Grayson, at the age of 92, who was believed to be the last of the pit women of the old days. When the act of parliament came into operation prohibiting women and girls, as well as boys under the age of 10 years, from working below ground, she was a young pit woman. In order to evade the act she disguised herself as a man, and continued to work in the mine for nearly 12 months, when she was discovered by the government inspector. In consequence of her experience of colliery life she was often called in to render service after mining disasters. Of her 13 children only two survive. She has, however, numerous grandchildren and great-grandchildren.



FIG. 7. RED CROSS MEDAL



FIG. 8. SILVER CUP CONTESTED FOR BY ANTHRACITE COMPANIES

Coal Mining in Arkansas

The Location, Geology, and Extent of the Fields. Methods Employed in Cutting the Coal

The following is taken from various parts of the Arkansas Geological Survey Report, Part I, Coal Mining in Arkansas, by Prof. A. A. Steel, and deals with the geology and entry driving in Arkansas:

The Arkansas coal field lies in the valley of the Arkansas River between the western border of the state and Russellville. It has roughly the shape of a Roman capital L with its base along the Oklahoma line. It is about 33 miles wide and 60 miles long, but it is only in the eastern and western parts of this area that the Hartshorne coal is probably thick enough or sufficiently free from partings to be of economic importance. Still, some 300 to 320 square miles will probably contain coal which may be mined. In places, the coal is over 8 feet thick, and when clean and of good quality, it has been mined where no thicker than 18 inches. The Hartshorne seam will probably average about 3 feet thick, and assuming this thickness over 310 square miles, that part of this bed which lies in Arkansas once contained something like a billion and a quarter tons of coal. The small amount of coal above and below the Hartshorne horizon may be nearly equivalent to that already mined, which was about 26,800,000 tons up to the end of 1909. At an average "recovery" of 80 per cent. in mining, the state will therefore yield only about 850,000,000 tons, but at the present rate of mining, this will last for 350 years. The rate of mining will probably increase.

Fig. 1 is an outline map of the Arkansas coal field, redrawn from the geological map in Mr. Collier's report.* It shows the counties, railroads, larger towns, and the coal mining camps. On this map is indicated the area underlain by the Hartshorne sandstone. This is the area ordinarily spoken of as the coal bearing area. The exact limits of the Hartshorne sandstone under Magazine Mountain and the eastern part of Poteau Mountains were not worked out by Mr. Collier, because the coal bed in these places is supposed to be of no value. A little coal has been mined from beds that are below the horizon of the Hartshorne sandstone. These are of importance chiefly south of Dardanelle. Unfortunately, the locations of these beds were not worked out sufficiently to be shown on the map. They are relatively unimportant.

Upon this map is indicated the area in which the Hartshorne coal is of known importance. Coal cannot be mined from every acre of this area because there are many small tracts in it that contain only faulty or thin coal. They are often too small to map, and the exact location of many of them will not be known until all of the good coal has been mined. This faulty coal occupies a considerable proportion of the areas of the mines already opened. Since the best part of the coal seam is opened first, there will be a larger proportion of faulty coal in

the remaining parts of the Hartshorne seam. The amount of this faulty coal has been guessed at in placing the ultimate recovery of the coal at the low figure of 80 per cent.

There are coal beds lying at a considerable distance above the Hartshorne horizon. These are of importance only at Paris near the center of the coal field.

Attention should be called to the fact that the largest part of the unmined area of thick Hartshorne coal lies beneath Sugarloaf and Poteau mountains. These tracts constitute by far the largest portion of the Arkansas coal reserves, estimated above. Unfortunately, most of this coal is under from 1,000 to 3,000 feet of rock and cannot be profitably mined until the price of coal is largely increased. It will, therefore, not be long until the scarcity of Arkansas coal becomes severe. It is hoped that there will be an opportunity to estimate as closely as possible the time that the relative cheap supply of coal will last. The newer workings of the mines, which are approaching the base of Sugarloaf Mountain, indicate that there is danger that the coal under it will be badly mixed with slate. This will reduce the reserve of good coal. The deeper coal is, however, harder than the more shallow coal.

Except in the small semianthracite coal mines all the entries and slopes are driven by a single method, which is called cutting.

Fig. 2 shows in plan the normal condition of a narrow entry

in a single bench coal after all the loose coal has been loaded out. The drill holes are ready for blasting in the night, or the shots are prepared, as the miners say. The narrow part which is generally 4 feet wide is called the heading. The T-shaped notch alongside of this is the cutting and is dug out by the miner, who kneels on the bottom and uses a light short pick. The cutting is from 4 to 6 feet long and only sufficiently wide to crawl into far enough to reach the end. It is made in

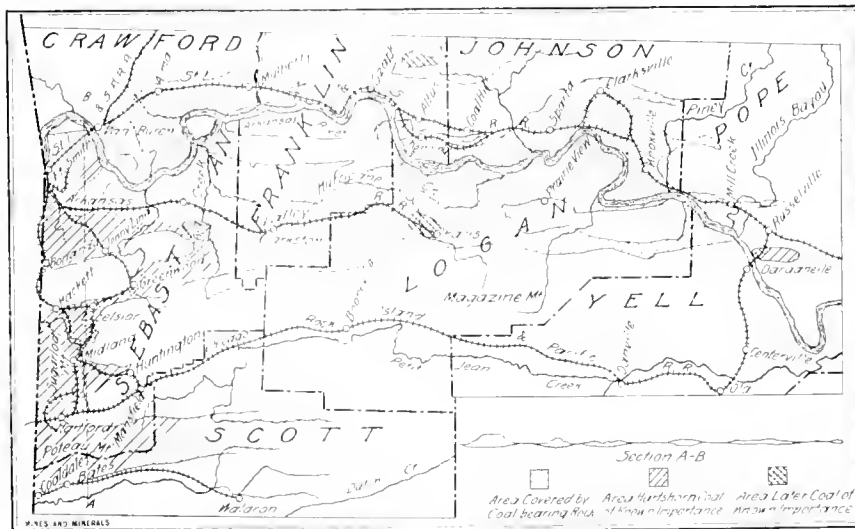

FIG. 1. MAP OF ARKANSAS COAL FIELD

from 2 to 4 hours, depending upon the skill of the miner and the hardness of the coal.

In the soft coal of Arkansas all holes for blasting are drilled with a breast auger. The cutting shot at *a*, Fig. 2, is placed about half way between the roof and floor on the side of the heading opposite the cutting. The hole is drilled 8 to 10 feet deep and from 2 to 4 feet on the solid, which means that it goes this far beyond the end of the cutting. When the powder explodes, all the coal between it and the cut is blown into the cut and heading. The coal which is too tight to be blown out is shattered and cracked, sometimes even beyond the end of the drill holes, as shown in Fig. 3. The shattering of the coal greatly reduces the labor of making the next cutting which is on the other side of the heading in the position shown by the dotted lines, and follows the hole just blasted. For the purpose of so shattering the coal more powder than necessary to loosen it is always used. The amount of powder is reckoned by the number of inches in the length of the cartridge. A 1½-inch cartridge has about 1 pound of powder for each 17 inches, and a 2-inch cartridge, which is more commonly used, 1 pound for each 10 inches. The ordinary 9-foot shot with 5½ feet of cutting is generally charged with from 36 to 42 inches, or 3½ to 4 pounds of powder. Except in the low-coal, two men work in each entry.

* Bulletin U. S. Geological Survey, 326

One of the partners is a skilled pickman who does the cutting or heading, while his partner does most of the shoveling or backing. Most of the miners get in a cutting every day, so 200 feet of heading will have an entry 5 or 6 feet per day. The rate per month for the working days is seldom more than 75 feet.

After the cutting is far enough ahead the miner puts in the back shot which is usually 9 or 10 feet long and throws out



FIG. 2. PLAN OF ENTRY READY FOR BLASTING

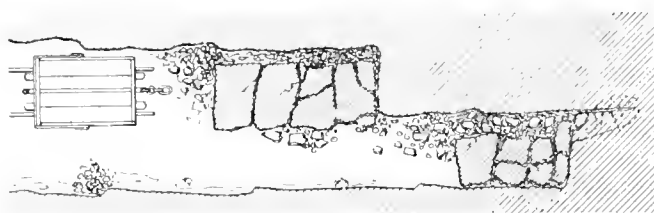

FIG. 3. AFTER BLASTING

a strip of coal from 4 to 5 feet wide with 30 inches or 3 pounds of powder. The less skilful miner generally blows this coal down so as to nearly fill the heading, and since he must be able to get at the cutting early to finish it before the end of the day, he must keep the heading well in advance of the back shot or there is no room into which to shove the coal from the cutting shot. As the car cannot be brought nearer than the back shot these miners have much extra labor in shoveling the heading coal back to the car. Under these conditions there is very little air-current in the heading and gas is liable to accumulate and burn the miner when he takes in his light. For this reason some foremen require that the back coal be first cleaned up before any one goes into the heading.

On the other hand, the skilful miner can so gauge his powder that the coal is merely well loosened for easy picking down, as shown in Fig. 3, but he runs the risk of leaving the coal too tight, so light shooting can only be done when the coal seam is uniform. When the light shot is successful the miner need shovel the coal but once before he can load it into the car, but occasionally he cannot get at the heading until after the back coal is cleaned up. In this case he loses time unless there are plenty of cars.

When there are two benches in the coal seam, they are sometimes so tightly frozen they can be shot out together. Usually, however, the middle band is so soft or loose that the holes will not always break top and bottom. In this case the heading is driven in the easier bench, and generally the back shot of that bench is fired next. If the top bench is left, it is then shot down by two light shots on each side of the entry, fired just after the back shot has loosened the coal below, or sometimes not until the coal from the back shot has been shoveled out. Since the solid coal along the side of an entry or room is always called the rib, such shots along it are known as rib shots. In rare cases one center shot brings down all the top coal. If the bottom bench is left, two rib shots are always used. These rib shots are fired alternately first on one side of the entry and then on the other, and each shot is about half its length ahead of the last. This makes a kind of cutting for the next shot, and the entire block of coal is pushed partly into this space and so shaken loose from the bottom or from any hard middle band above it. In a few cases the benches are not so easily separated. Then the cutting is made in only one bench as usual, but the other bench is shot out of the heading before

it is widened, so that a single back shot will widen both benches.

In case there is a considerable quantity of waste between the benches of coal, there would be a little delay and expense in hauling it out. To avoid this, the entries in Arkansas are often driven 12 to 14 feet wide by putting in another row of back shots behind the first row, or on the other side of the heading. This widening of an entry is called slabbing it. The track is then laid next the upper side of the entry, and waste piled along the lower rib.

Fig. 4 is the plan of such a gob entry. It shows also a room neck and a cross-cut from the air-course, and the way the bottom bench is usually taken up. If the middle band is so soft as to be easily shoveled off the lower bench without blasting, it is usually cleaned out of the heading before the back shots are fired. Where quite hard, it is always left until the bottom shots are fired. These, if properly charged, shake the rock loose from the bottom bench, and break it up for easy picking without mixing coal and rock. Fig. 5 is a cross-section of a gob entry.

As gob entries are necessarily wide, the roof is weak, and generally at least one row of props is set alongside the track. The bottom of the prop is first set upon the floor and a cap piece about 4 inches wide, 15 inches long and 1 or 2 inches thick is held against the roof while the prop is set under it at a small angle from the vertical. The prop is then securely wedged into place by driving it plumb, with an ax or sledge. If the roof is unusually weak, as where the coal is near the surface, it is supported over the roadway by cross-bars. These are logs 6 or 8 inches in diameter, reaching from side to side of the road and placed as close together as is necessary. The ends of the cross-bars may be held up by cutting hitches to form a little shelf of coal, if it is hard. Very often the coal is too soft or the entry too wide for hitches, and an upright post

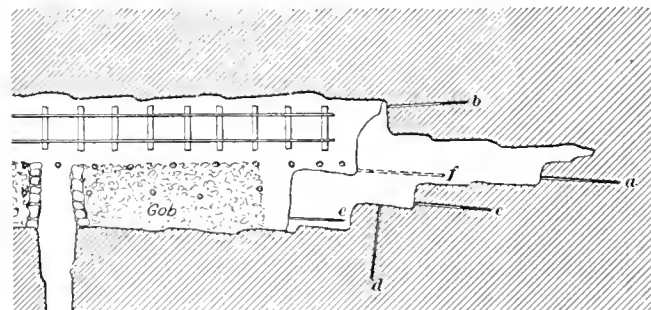

FIG. 4. PLAN OF TRIPLE-BENCH ENTRY

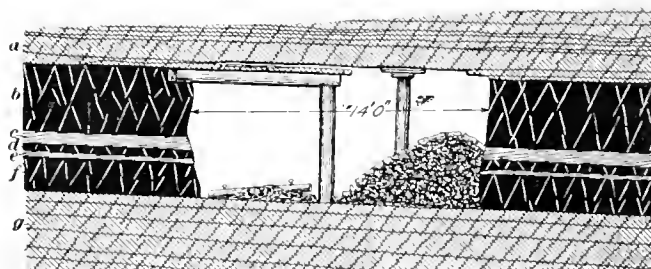

FIG. 5. CROSS-SECTION OF ENTRY

or leg is set under one or both ends of the cross-bar. Fig. 5 shows such a cross-bar with a hitch at one end and a leg at the other.

When the coal seam is too thin to give the height required for a mule, the entries are usually made higher by brushing them or blasting down the rock over the roadway. The roof at all of the mines in Arkansas where brushing is done is so hard that

the holes must be put in with some kind of a post drill. These are called machines or at times Hardsoeg drills, since that firm supplies most of the drills used in this coal field.

In harder rock a ratchet drill, most frequently of the Nixon make, is used. An iron post with a jack-screw at the end is supplied with the drill to hold it against the rock, but in some cases the miner sets up a temporary prop as a substitute for the regular post.

The drill operates in the same way as a machinist's ratchet used for drilling holes in metal. When the drill is rotated by the ratchet handle, the thread bar in the pipe opposite the auger is screwed forward at a rate depending upon the hardness of the rock.

The holes for blasting down the roof are drilled upward at a slight angle to reach a little more than the required height above the rail. A single row of shots over the center of the track is enough to break the entire width, and each shot breaks the rock to a sufficient height for some distance beyond the end of the hole. The rock is usually blasted with black powder, which causes the hole to run ahead farther. Sometimes a stick of dynamite is added to break the rock into smaller pieces if it is hard.

Brushed entries are nearly always wide to provide room in which to pile the waste rock, and that part of the roof which is not to be shot down must be securely propped. A line of breaking props

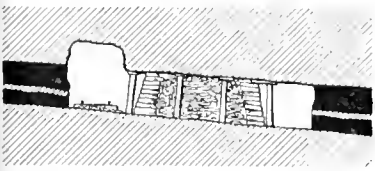
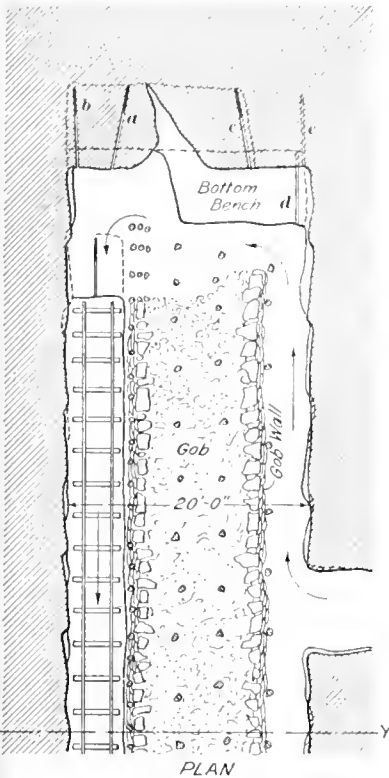

SECTION ON X-Y.
FIG. 6. BRUSHED ENTRY

only 12 to 16 inches apart is set along the edge of the brushed part of the entry to break off the slabs of slate loosened by the shot. If the rock is very hard, a triple row of props, as shown in Fig. 6, is sometimes used.

Fig. 7 is an ideal view of a brushed entry in higher coal. This shows also the heading and the cutting. The block of coal to be removed by a back shot is shown upon the left side of the picture, but is somewhat obscured by the drill. A machine used for drilling the hole for the brushing shot is shown in position, and the end of the last brushing shot can be seen in the roof in front of the machine. (For the sake of clearness, the width of the brushing has been shown wider than usual and the gob space behind the breaking props is correspondingly narrow.) The rock removed from the roof is carefully stacked only when there is but little room in which to put it. Quite frequently the roof slate is piled along the roadway in the middle of the entry only, so the air, coming from a cross-cut behind it is carried on to the face of the entry before returning. This greatly helps the ventilation.

If, as at some of the semianthracite mines in Spadra and Russellville, there is enough waste to fill the space, a gob wall of the larger flat stones is built along the outer edge of this waste to maintain the passage for the air-current. Fig. 6 shows

the plan and section of such an entry, and also the method of driving it in the hard unexplosive coal. This is the method used in the rooms at these mines. The slanting shot is more heavily loaded than the others, and is fired first, generally breaking the coal as shown. The next day the shots *a, b, c,* and *d,* will all be fired. The hole *d* is in the bottom bench and reaches only a foot or so into the solid under the top bench and is not heavily

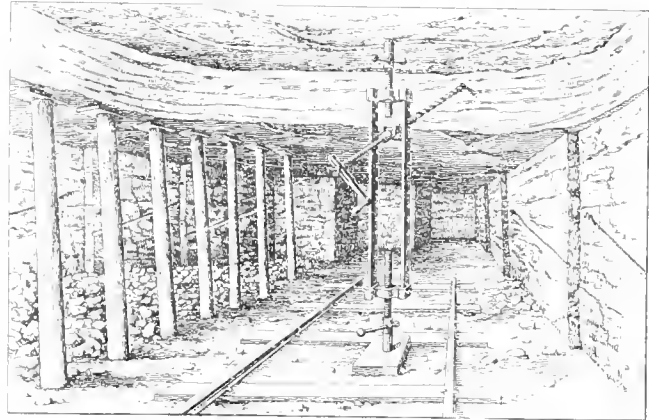

FIG. 7. BRUSHED ENTRY IN HIGHER COAL

charged. On the following day after this coal has been loaded into cars, the shot *e,* and a rib shot in the bottom bench under shot *c,* with possibly another opening shot will be fired. If the middle band is hard rock, that bench which most easily separates from the band rock is shot first. If both benches are loose, the thicker one is shot first.

Instead of shooting down the roof, or top brushing, room for the mules in the entries in low coal can be made by digging into the floor or taking up bottom as it is usually called. This is also known as bottom brushing. In Arkansas this is done only when the roof is hard sandstone which cannot be drilled by any kind of auger drill.

來 來

Rope Sheave for Curves

A. J. Reef, assistant chief engineer, Victor-American Fuel Co., Denver, sends us the accompanying sketch of a very satisfactory self-oiling sheave wheel used on heavy grades in connection with heavy loads at the Radiant mine of his company.

It will be noted that the axle of the wheel, which is of steel, and upon which the wheel is shrunk, is made unusually long in order to withstand the heavy strain to which it is subject. The axle runs in cast-iron upper and lower boxes bolted to heavy posts set in the ground and back braced as shown.

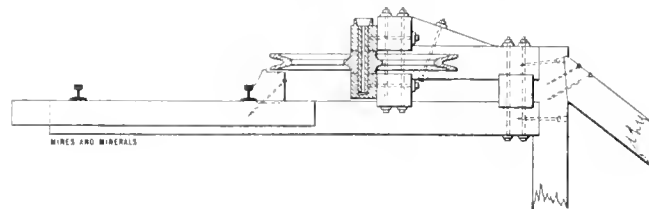

ROPE SHEAVE

Through the center of the axle is bored a 1/4-inch hole and to its top is fixed a funnel-shaped cup for oil. The bottom of the lower box is made convex to provide a bearing (in part) for the axle, but more particularly is intended as a receptacle for oil, which, fed in through the funnel, passes down through the central hole and, by capillary attraction, up between the shaft and the boxing.

Mr. Reef suggests that where this single hole does not afford sufficient lubrication, holes at right angles to the shaft might be bored from its outer bearing to the inner oil tube, and, further, that it might prove an economy in oil to use an automatic oil cup instead of the funnel.

Tentative Plan of Shaft Bottom

Arrangements for Handling a Large Output on Single-Deck Cage in Shortest Time and at Lowest Cost

By William B. Crawford*

[EDITOR'S NOTE.—This article on a proposed shaft bottom was written by request, in order that the readers of MINES AND MINERALS might have an opportunity to express their views fully on a subject which is yearly growing in importance.]

On the other side of the Atlantic two- and three-decked cages are employed to approximate an output which in this country is accomplished on a single-decked cage. For economical reasons both inside and on the surface, single-decked cages are preferred, but they can only be adopted where shaft bottoms are suitably arranged for moving large quantities of coal quickly.

In opening a shaft mine, the arrangement or layout of the shaft bottom is of prime importance and should be given the closest study and attention to devise the plan or system best adapted to meet the requirements of the particular case.

Several plans for standard shaft bottoms have been proposed, but as a matter of fact, no one plan can be accepted as standard for all

shaft bottoms, each individual case requiring special arrangement to meet the local conditions and requirements.

In a general way certain plans can be followed, keeping in mind local requirements and treating each case independently, with the idea of accepting only such part of any plan as will meet all conditions to best advantage.

The plan herewith submitted is not intended as a standard lay-out to cover all cases and conditions, but is designed to meet the requirements incidental to mining a 5-foot seam of coal, lying fairly regular, and to produce the maximum tonnage in the shortest limit of time and at the least cost.

* Coalwood, W. Va. General Manager Virginia-Pocahontas Coal Co.

The production and economical operation of any shaft mine depend largely upon the speed and accuracy with which the mine cars are handled at the shaft bottom and returned to the working place, and to accomplish this in the shortest time and in the surest and most practical manner is the result aimed at.

The main shaft will be 15 ft. x 26 ft. in the clear outside of timbers, by 600 feet in depth, and will have two hoisting compartments each 7 ft. 4 in. x 13 ft. in the clear, and also a compartment 5 ft. x 13 ft. in the clear for a stairway, piping, wiring, and signals.

The air-shaft will be 14 ft. x 20 ft. in the clear, outside of timbers, with a hoisting compartment 7 ft. 4 in. x 12 in. in the clear, equipped with man and material hoist.

Tracks will be 48-inch gauge; mine cars will hold 4 tons of coal, and it is calculated that the maximum production will be 4,000 tons per 10 hours.

The mine will be laid off in panels and worked on double-entry room-and-pillar system, rooms being turned on 60-foot centers and driven up from 30 to 40 feet in width, as conditions may determine.

Main cross and butt entries will be driven 12 feet in width and on 32-foot centers, leaving only a 20-foot pillar between entries. This is in order to facilitate the making of break-throughs and the rapid progress of development work possible thereby. The support for these entries is secured by the heavy pillars left on either side of the pairs of entries.

All haulage is

on return air, separate entries and tracks being provided for loads and empties and so arranged as to prevent interference between haulage locomotives and trips from the same and opposite side of the mine, it being intended that locomotives from the south mains shall use the right-hand loaded tracks and empty yards exclusively, and that those from the north mains shall use the left-hand loaded tracks and empty yards exclusively, only crossing to the opposite sides in case of necessity, such as occasioned by wreck or breakdowns of some kind on their respective hauls.

The main bottom or approach for loads is 700 feet in length from the main shaft to the south curves turning in from the main

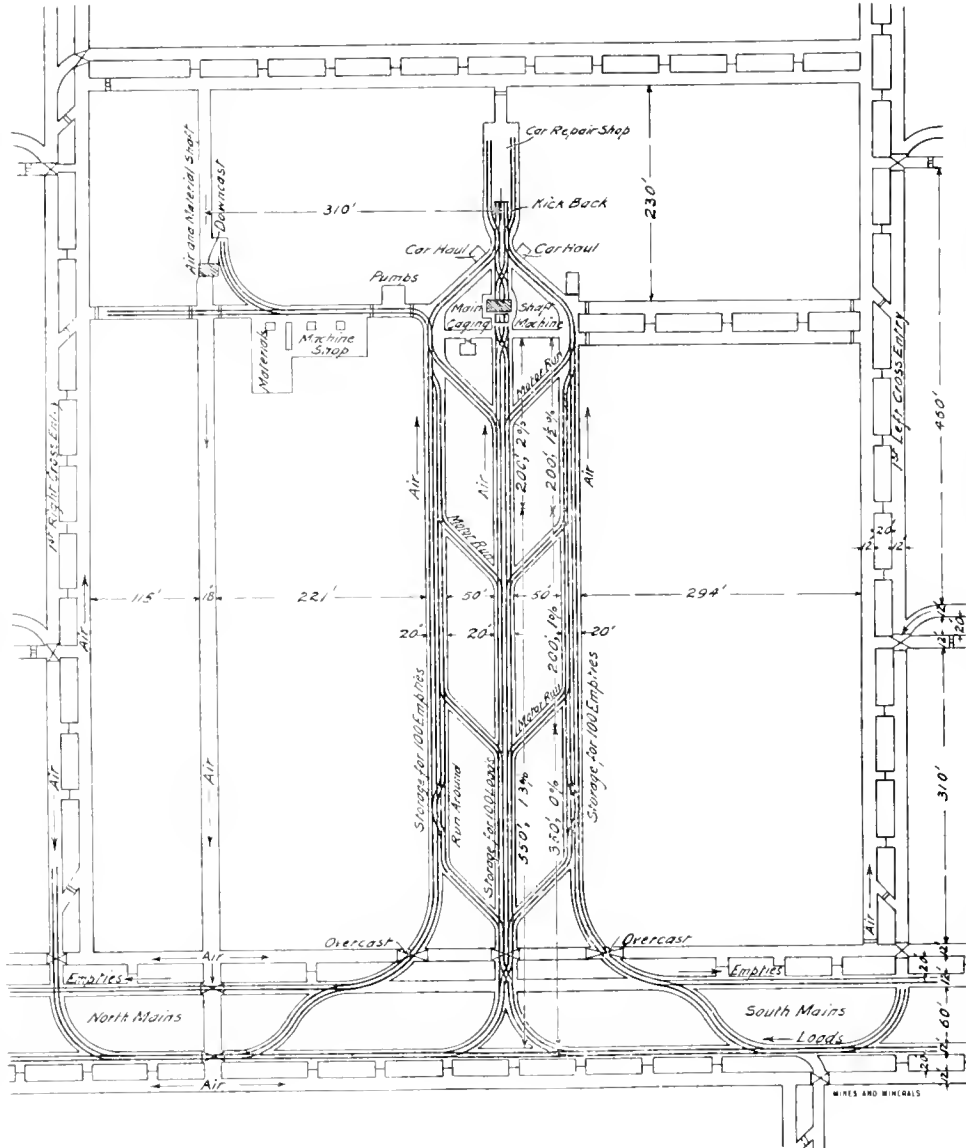

PLAN FOR SHAFT BOTTOM

haulways and on a gradient toward the shaft of from $1\frac{1}{16}$ to $2\frac{1}{8}$ per cent. This approach is double tracked and provided with crossovers at convenient points to allow the placing of loads on either track at any desired point.

Motor runs are cut through at intervals of about 175 feet to the empty yards. These yards are each 500 feet in length with three tracks and provided with crossovers and switches at each motor run, so that the locomotives can reach any desired point in the string of standing cars and be able to pick up their empties either in front or behind the locomotive and return to the workings without delay.

Loaded cars, after being cut loose from the locomotive, are dropped to the shaft by gravity, being controlled by their brakes and are handled on and off the cages by automatic caging machines, placed directly in front of the shaft. The empties leaving the cages, run on to a kick-back and are shunted to the foot of the car hauls, passing around on either side of the shaft, which delivers them to the top of the empty yards, from which point they are allowed to travel by gravity down into the yards to be made up into trips as desired.

The space beyond the kick-back will be equipped as a car repair shop and cars can be passed into or out of the shop on either side of the kick-back, storage room for "cripples" being conveniently located on the pair of butts crossing immediately behind the car shop.

Pump room, machine shop, material and supply depot, office and other stations are conveniently located around the shaft bottom as shown. All are to be lined and arched with reinforced concrete and provided with steel doors.

The system of ventilation may be either by blowing or exhausting, although in the present case, a force fan will be used and the main hoisting shaft will be the upcast. Concrete overcasts are to be placed wherever necessary, and doors eliminated, except on butt entries and passageways.

The mine will be equipped with electric locomotives, coal-cutting and loading machines, telephone and signal system, and the most approved equipment for fighting fire and mine-rescue work.

Refuge chambers and first-aid stations will be located at suitable points in the mine and every attention will be given to the providing of the greatest possible safety both to those employed and to the mine itself.

采 采

Our Cover Picture

Since the discovery of gold in 1903 by Messrs. Meyers, Murphy, and Taylor at what is now Goldfield, Nev., it is estimated that \$42,000,000 has been taken from the ground. Probably one-half of this amount came from the mines included in the Goldfield Consolidated properties. In 1910 the Goldfield Consolidated mill, shown on the front cover, took fire. It was so quickly repaired, however, that the dividends from the mines were only slightly impaired.

The B. & K. Coal Jig

By N. R. Marcin

The chief points of interest in the newly developed B. & K. coal jig are the motion given to the pan and the automatic slate discharge. The pan is suspended in the jig box by hangers *a* suspended from shaft *b* at one end in such a way that with plunger rod *c* connected by eccentric to shaft *d* at the other end, it is given a horizontal oscillating and a vertical reciprocating motion. These combined motions cause the material in the pan to travel forward at the same time that the slate and coal are separating by gravity. Between the points of coal and slate discharge there is a space 12 inches to provide ample margin of safety in the adjustment of the automatic slate discharge. The slate gate *e* is pivoted at *f*, the other or free end is attached by reach rod *g* to the lever *h* with a balance weight *i*.

When the bed of slate becomes so deep as to overbalance the counterweight *i* on the lever the gate *e* opens and permits the slate to flow out into boot *j* of the hutch, from which it is removed by scraper line shown. The slate gate opens intermittently but at frequent intervals when the jig is working at full capacity. The pan is of iron with its bottom perforated with $\frac{1}{4}$ -inch diameter holes for buckwheat, pea, and nut coal, and it is given 85 strokes or shakes per minute, each having $\frac{1}{4}$ -inch travel forwards and the same number and travel backwards. The pan for jigs making stove and egg coal is perforated with $\frac{3}{8}$ -inch diameter holes and given 82 shakes per minute with a travel of 1 inch forwards and backwards. It requires little power and little water to run these jigs, while they have a large capacity, as will be seen from the table of tests made at the Midvalley Coal Co.

In the test of buckwheat (run-of-mine) the quantity of slate in coal is far below the amount which will pass inspection, whereas the test of buckwheat (condemned coal) is well within the passing limit, thereby

showing possibilities of control by adjustment with the B. & K. jig.

Test of Double B. & K. Jig at Midvalley Colliery No. 2. Pea coal, run-of-mine, input to jig, $15\frac{7}{16}$ tons per hour; output, 75 per cent., or $11\frac{1}{16}$ tons per hour of coal containing 7 per cent. slate, and 25 per cent., or $3\frac{11}{16}$ tons per hour, of slate containing 2 per cent. coal.

Buckwheat, run-of-mine, input to jig, 21 $\frac{1}{2}$ tons per hour; output, 88 per cent., or 18 $\frac{3}{4}$ tons per hour, of coal containing 2 $\frac{1}{2}$ per cent. slate, and 12 per cent., or 2 $\frac{1}{2}$ tons per hour, of slate containing 1 per cent. coal.

Buckwheat, condemned coal, input to jig 21 $\frac{1}{2}$ tons per hour; output, 94 per cent., or 20 tons per hour, of coal containing 7 $\frac{1}{2}$ per cent. slate, and 6 per cent., or 1 $\frac{1}{2}$ tons per hour, of slate containing 2 per cent. coal.

Stove coal, run-of-mine, input to jig $20\frac{5}{16}$ tons per hour; output, 63 per cent., or $16\frac{1}{16}$ tons per hour, of coal containing 1 $\frac{1}{2}$ per cent. slate, and 27 per cent., or $10\frac{5}{16}$ tons per hour, of slate containing 2 per cent. coal.

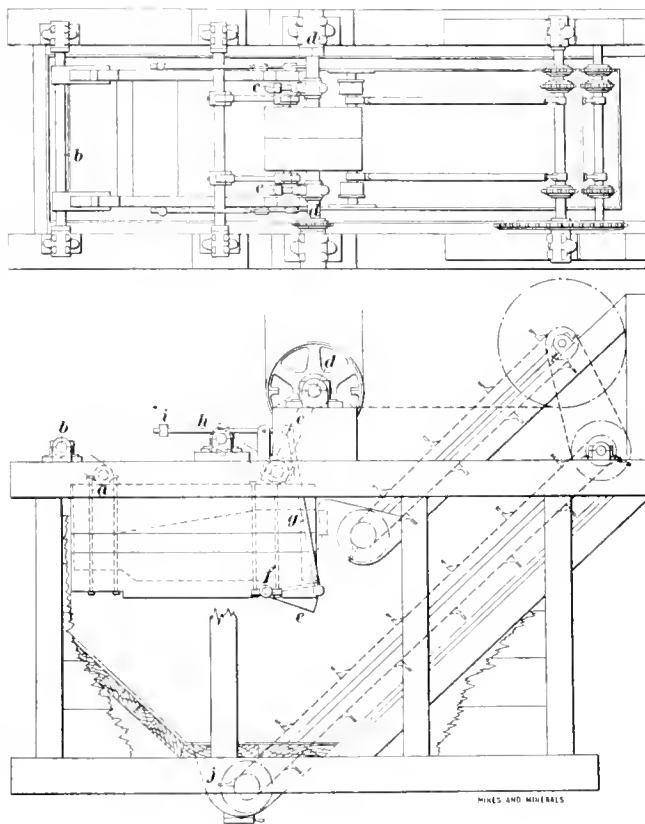

B. & K. COAL JIG

Heilwood, the Model Mining Town

An Example of Modern Method of Treating the Living Problem in an Isolated Camp

Tucked away in the eastern central part of Indiana County, Pa., is a mining town not on the railroad map or timetable. This town, called Heilwood, belongs to the Pennsylvania and Maryland Steel companies, who own the surrounding country for many square miles. While not extravagant with their money, they have built this town with the evident object of securing a good class of miners and retaining them. The Cherry Tree and Dicksonville Railroad, a branch road jointly operated by the Pennsylvania and New York Central, has a station near Heilwood called "Possum Glory," and if one desires to see this model mining town (not model mines, as they blow up) he must take this road or drive from Barnesboro, 12 miles distant. At Heilwood the operatives of the Penn-Mary Coal Co. live in luxury, if their dwellings and surroundings are compared with those of most mining towns; indeed, the town has the appearance of a well-kept country village. The coal mines, five in number, give employment inside and out to about 1,000 men, and if to this number the women and children be added the population of the town of Heilwood will approximate 2,000.

The company officials understanding that General Manager H. P. Dowler, who lives at Heilwood, is more in touch with the conditions that effect the welfare of this little community than an absent official could be, rely on his judgment in the matter of expenditures for the common good of all concerned.

Realizing that Heilwood is to be a permanent town that must increase in population as more mines are opened and the present mines are more extensively developed, all buildings are constructed in a substantial manner and with a view to present and future sanitary conditions. The town, situated on high ground, affords good drainage facilities and is systematically blocked with streets that provide a certain number of 50' x 150' building lots in each block. From the illustrations it will be seen that single houses have been constructed with a view to family privacy. Each house has plumbing that connects it with a town water system which supplies excellent water from two wells 800 feet deep, and which insures freedom from sickness due to impure water. The management states with satisfaction that not only are the people clean and healthy, but that there has never been a case of typhoid fever that originated in the village. The houses and town streets are lighted by electricity. Frequently the phrase "mining camp" is used by writers, and it is usually suggestive of a place of shacks littered with garbage, tin cans, old shoes, a possible dead cat or something similar; it will be observed, however, that the term village has been used

in this article and it is not amiss, for the unattractive attributes to the camp are wanting.

All coal mined by the Penn-Mary Coal Co. is shipped to the plants of the Pennsylvania and Maryland Steel companies, where it is coked in by-product ovens or used for other purposes in the manufacture of steel, and this policy is likely to be continued indefinitely. The company, basing its policy on the experience of other coal companies, refuses to sell land in the vicinity of Heilwood, the reason being that land once gone from its control offers an opportunity for undesirable citizens to obtain a foothold in the community.

It was understood, however, that in such a comparatively isolated place arrangements must be made to entertain commercial travelers and visitors, and to that end a hotel was built. There is a law in Indiana County that makes it illegal to treat (which must appeal to the fellow whose best girl has a fancy for bonbons, ice cream, and soda water), and since it is almost necessary for some miners to have beer, there is an irrigating station connected with the hostelry, but so regulated that drunkenness is frowned upon. Opposite the hotel there is a restaurant, not a cafe, where one can obtain lunch except when

the proprietor shuts up and goes home to meals. The justice of the peace has his office next door with a large sign fronting the hotel that is calculated to inspire the same feeling as the sign "Beware of the Dog." As a rule miners are religious, and to afford them spiritual nourishment two churches have been built, one for the Roman Catholics and one for the Protestants.

Going up the street, the Heilwood Company store attracts attention. This department store, which is independent of the Penn-Mary Coal Co., is managed by J. M. Thompson. Aside from its general cleanness and neatness it has a butcher shop that is new and interesting. Most of the fresh meat is obtained from native cattle, and since such meat is tough when sold shortly after killing, it is customary to hang the dressed carcass in cold storage for 10 days before distributing. We know of no other coal company which goes to such lengths in order to please its employes, and even then the meat is sold from 10 to 20 cents less per pound than equally good meat in eastern Pennsylvania. A short distance from the store and on the same side of the street is the general office of the Penn-Mary Coal Co. This is an attractive brick building with roomy offices downstairs and excellently appointed engineers' offices upstairs. The building is steam heated and electric lighted, with fireproof vault for storing such valuables as are likely to be destroyed by fire. Opposite the office and some distance back from the street is the handsome colonial residence of Mr. Dowler; however, he has not cornered Heilwood residences, as can be seen by reference to Fig. 3. At the end of the main street is a park in which there is an imposing buff-colored brick building. This is the public school building, erected and



FIG. 1. THE TOWN OF HEILWOOD, PA.

maintained by the company for the benefit of the children of its employes. At present there are 250 pupils with a corps of competent teachers. Opposite this building there is a fine dormitory erected for the women teachers who room and board there. This building is supplied with modern improvements, which no doubt is comforting to those who have been wrestling through the day with budding statesmen and suffragettes.



FIG. 2. PENN-MARY HOSPITAL.

In a mining town of the size of Heilwood there is always more or less sickness among the women and children, besides the men incapacitated through injuries received at their work in the mines. To make sure that the sick and injured are properly treated the Penn-Mary company erected a hospital, which, while not large, is probably the best appointed in the state. In it there are wards for children, men, and women, besides private rooms, all of which are equipped with steel furniture, sanitary base boards, and curved wall angles to guard against the lodgment of disease-breeding germs. Mr. Dowler has furnished a room in this building for the sick who need privacy, that contains handsome furniture all in enameled steel that resembles oak. The doors in the interior of the building are steel, but enameled or veneered to resemble wood. Doctor McKinley, the resident physician and surgeon, had much to do with the design of this hospital and its furnishing. Being up to date and bearing in mind the disadvantages under which he was compelled to work in city hospitals, he instituted improvements which have been incorporated in this building. The operating room has a glass ceiling which furnishes an abundant supply of light during the day; it is also equipped with electric lights and portable electric lights and reflectors for night operations.

Whenever an injured man is brought from the mine he is taken in the basement of the hospital, washed, placed on a cot and elevated to the operating room where his wounds are properly dressed.

There are several sterilizing appliances in the building and such water as is needed for washing wounds is filtered and sterilized before being applied. Connected with the establishment is an X-ray machine imported from Germany and said to be the only one of its kind in this country. The spark is not generated in the usual way by glass plates but by means of rotating parts revolved by electric motor. In the basement there is an X-ray room, bathroom, steam

laundry, kitchen, nurses' dining room, boiler room, and storeroom.

It must not be imagined that because the company has built a hospital at this early stage of its career it fails to take every possible precaution to prevent accidents in the mines. No manager wants a man injured and most managers suffer mentally when an accident occurs, particularly if it happened through his negligence; however, so long as there is mining there will be accidents, which may be minimized if the men will cooperate with the management and not assume risks.

采采

Trade Notices

Rubber Footwear—Miners who work in wet places must wear rubber boots if they expect to keep their feet sound and free from sores. The conditions surrounding wet work are such that a poor quality of rubber will not wear long. Owing to the price of rubber having advanced steadily in recent years unscrupulous manufacturers use adulterated rubber to keep down the price and induce people to purchase their goods. The Mishawaka Woolen Mfg. Co., of Mishawaka, Ind., had such difficulty in buying satisfactory rubbers to go with its all-wool boots and socks that it undertook the manufacture of rubber boots and shoes, with the avowed object of making the best possible footwear for mine service.

Their goods, under the trade name of "Ball Band" met with such success it is claimed that 8,000,000 people wear "Ball Band" footwear. The manufacturers claim that they put \$1,000,000 extra value into their footwear each year over what would be necessary to turn out ordinary fairly good boots and shoes. Most dealers can supply "Ball Band" goods, but if not, the manufacturers will see that the user is supplied if he will write to them direct, giving the name and address of the dealer from whom he buys his shoes.



FIG. 3. HOUSE OF GENERAL MANAGER AT HEILWOOD



FIG. 4. HOUSES AT HEILWOOD

Max Fanc--J. R. Robinson, engineer, Pittsburg, Pa., is now installing for the Poston-Consolidated Coal Co., at Athens, Ohio, a fan of 60,000 feet capacity; one for the Beech Bottom Coal Co., Wellsburg, W. Va., 80,000 feet capacity; one for Hutchinson Coal Co., at Reynoldsville, W. Va., 125,000 feet capacity; one for Madeira-Hill-Clark Coal Co., at Wilsonburg, W. Va., 150,000 feet capacity; one for Pennsylvania Coal and Coke Co., Cresson, Pa., 150,000 feet capacity; one for Keystone Coal Co., White Station, Pa., 150,000 feet capacity; one for

Grade Coal and Coke Co., Sykesville, Pa., 300,000 feet capacity of 6-inch water gauge; one for Federal Coal and Coke Co., Grant Town, W. Va., 300,000 feet capacity at 12-inch water gauge.

You Can Save Assay Expenses.—The Way's Pocket Smelter Co. of South Pasadena, Cal., reports an unusual demand for their outfits from persons who wish to use them for experimental purposes, and for testing ores in connection with their study of mineralogy. The company is now supplying a cabinet of ores at a low cost, and by testing these with Way's process, the person can get a knowledge of ores and minerals that is worth a year's reading of books.

New National Electrical Code Rules.—The new rules in regard to insulated wires and cables that have been adopted by the National Board of Fire Underwriters went into effect on October 1. The Hazard Mfg. Co., of Wilkes-Barre, Pa., has issued a booklet showing the new specifications and also describing Penn wires and cables, which are made to conform to the requirements of the new rules in all particulars. Full information is also given in regard to the Hazard 30 per cent. Para, and the Keystone 25 per cent. Para rubber insulation which is used by the company in the manufacture of covered cables for all electrical work. Dealers are allowed till July 1, 1912, to dispose of stocks on hand and after that time only wire conforming to the new specifications will meet the approval of the National Board of Fire Underwriters. The Hazard company will send a copy of the booklet on request.

Pile Hammers.—The increasing use of sheet piling in excavating running ground has brought about the development of driving appliances. The McKiernan-Terry Drill Co. has issued a bulletin entitled "Pile Hammers," describing the machines and giving facts regarding accomplishments in actual work. It is worth sending for by any one interested in the subject.

Modern Coal Mining Plants is the name of a booklet issued by Roberts & Schaefer Co., Chicago, containing some fine pictures of coal mining plants built by them in different parts of the country. Many of these are of large capacity and all are examples of the best modern practice. This booklet is No. 22 and will be sent on application.

Tests of Turbine Pumps.—"Comparative Tests of Large Engine- and Turbine-Driven Centrifugal Pumps," is the title of an article by Francis Head, Member of American Society of Mechanical Engineers, which recently appeared in one of the technical journals and has been reprinted by the DeLaval Steam Turbine Co., of Trenton, N. J. "Steam Turbine Centrifugal Pumps and Other Centrifugal Machinery," is a 32-page booklet issued by the same company, illustrating and describing the several lines of machinery manufactured.

Need of a Good Light.—The importance and economy of having plenty of light for men to work by is beginning to be appreciated by mine operators, and endeavors to furnish this have been made along several different lines. One of the brightest lights and at the same time simplest and cheapest is the acetylene lamp. Among the newest of these is the lamp made by the Maple City Mfg. Co., of Monmouth, Ill. This lamp is charged with calcium carbide and water in the usual manner, but has a number of points in regard to durability and accuracy of adjustment that must be seen to be appreciated. The lamp furnishes a 10-candlepower light at less cost than oil. The company will send a sample lamp free to any mine superintendent writing for it on a company letterhead.

Slope Drill Contest. The committee of the *South African Mining Journal*, under date of September 23, in commenting on a pamphlet entitled "Results of the Slope Drill Contest" which has been widely distributed in the United States and which had the appearance of being published by the *South African Mining Journal*, says: "This pamphlet was not issued by our office, does not quote us correctly, and has been published without our knowledge."

The Goulds Mfg. Co. opened a branch house at Ohio and Franklin Sts., Chicago, Ill., on November 1, to handle their

business in the Middle Western territory, including the states of Indiana, Illinois, Michigan, Wisconsin, Minnesota, and Iowa. This branch will take over the entire business of the present Goulds company, with the exception of their line of centrifugal pumps. The branch house will exploit the new line of volute centrifugal pumps, which are made in the Seneca Falls factory along with the rest of the company's complete line, including hand-lift, force, and windmill pumps, spray pumps, both hand and power, rotary pumps, centrifugal pumps, air compressors, vacuum pumps, etc., in fact, all types of pumping equipment for every service.

Will Make Steel Cars.—The Hockensmith Wheel and Mine Car Co. have taken up the manufacture of steel cars and erected a special shop for this purpose. It is a steel and brick structure 100 ft. × 200 ft. in size and near to the other shops comprising the plant. Railroad tracks enter and cross through one end, by which all material is delivered, and on which the finished cars are loaded under its roof. The shop is equipped with the latest improved machinery for shaping and preparing the steel plates, and an overhead electric traveling crane for handling the material throughout the shops. The company proposes to equip their steel cars with their patent angle-bar truck in which is incorporated cold-rolled steel axles, and special axle box, and the straight-spoked annealed "Eureka" wheels. This truck has given satisfactory service in the principal districts of the United States, British America, and Mexico, and will be a strong feature of the new steel cars. In addition to these improvements, there has recently been built a large annex to the smith shop, the capacity of the electric power plant has been doubled, and the floor space in the foundry increased, so as to admit increase of from 500 to 900 annealed mine car wheels per day.

Asbestos Roofing.—Asbestos roofing is looked upon as a natural protection against all destructive elements, because it is made of a natural mineral that has already proved to be practically indestructible by not being injured by exposure to the elements for centuries. According to the process used by the H. W. Johns-Manville Co. in making the "J-M" roofing, several layers or sheets of asbestos felt are cemented together with Trinidad Lake asphalt—the same as used for street paving. This makes an all-mineral roofing that is practically as permanent as the brick walls or any other inorganic part of a building. Fire cannot get through an asbestos roof from the surface; and from underneath, only after the sheathing boards and timbers have burned away and allowed it to fall. A white surface "J-M" asbestos roofing has been made for use where comparatively low summer temperatures are desired on the inside of the building. A test made at a Cleveland, Ohio, clothing factory in the summer of 1908, showed a difference of 18 degrees between a black and a white-surface roof, the thermometers being suspended 4 feet below the under side of the roof. While formerly asbestos roofings were laid with copper flashings, by the "J-M" process the entire roof, including flashings and gutters, can be laid with the asbestos roofing.

Emergency Treatment.—To get the best results from the ordinary first-aid outfits some knowledge in regard to methods of using the materials in them is necessary; and where regular first-aid instruction is not possible a good book is the next best thing. To meet this need, Johnson & Johnson, of New Brunswick, N. J., who are well-known manufacturers of first-aid and surgical material, have had prepared a book entitled "Johnson's First-Aid Manual" which gives, in plain language, with many illustrations, full instructions for treatment of emergencies, both with the materials furnished in the usual first-aid packets or with such materials as may be obtained anywhere. Besides these directions it contains valuable information as to sterilization, care of sick room, treatment in cases of poisoning, and handling of contagious diseases. This book is furnished free with the first-aid outfits sold by this company. Its price, postpaid, is 50 cents.

Mine Survey Notes

As descriptions of several systems for keeping mine survey notes have appeared in MINES AND MINERALS during the past year, the system herewith described may be of interest for purposes of comparison. This system of note keeping has the following points to commend it.

No special form of book is required, as any standard engineers' field book will do.

It is simple, as all the data concerning any station in a mine are recorded in the note book, on the same line as the station.

Sketches can be made showing the working places just as they actually are in the mine at the time of the survey. A draftsman may be called upon to make a map of a mine, portions of which are completely worked out, from notes taken years before. This he cannot do without accurate sketches, hence their almost absolute necessity.

When called upon at the mine to locate two entries to connect, or similar work, the engineer is saved the time and trouble of making a new traverse or survey, which he would of necessity have to do if his latitudes and departures were

On the opposite side of the page sketches are made showing the plus to the center of all cross-cuts, sumps, manholes, rooms, etc. While no attempt is made to keep these sketches to scale, they are supposed to look as nearly as possible like the entries being surveyed. On this page is also shown a section of that part of the coal seam which is being worked, at each survey station, or at least every 300 feet.

The survey stations are of course put in as needed, but regular extensions are made every 3 months, the plus to the face from the last station being shown in the sketch, with its survey letter, the date of the survey letter being shown in the corner of the page. These survey letters are also used on the maps instead of a date.

In the front of the entry books two sets of indexes are made, one showing the page of the book in which any entry survey may be found, the other indexing the station numbers in consecutive order, showing on what page of the note book and in what entry they are located.

The room notes are kept in a separate book, similar to the ones used for entry notes but both sides of the sheet may be used for sketches as no transit notes are recorded.

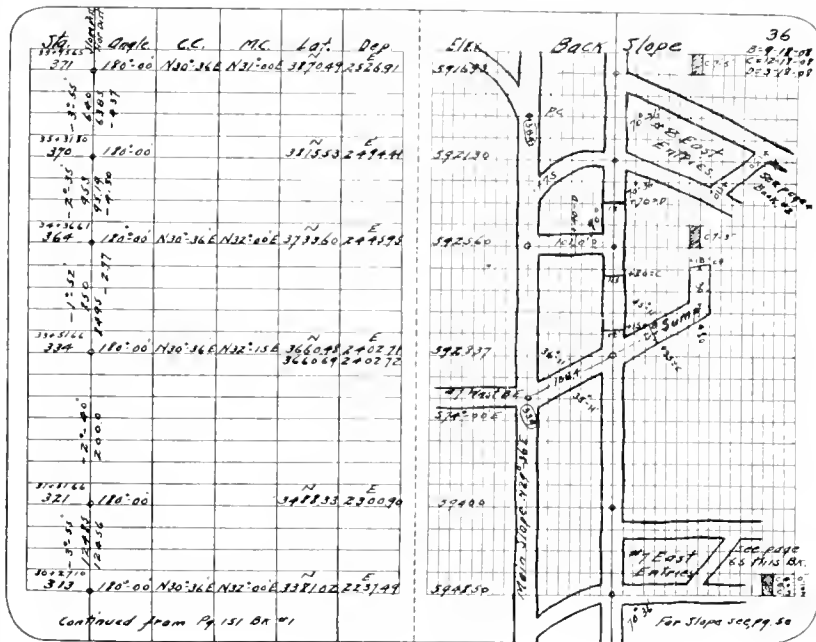

FIG. 1. ENTRY BOOK

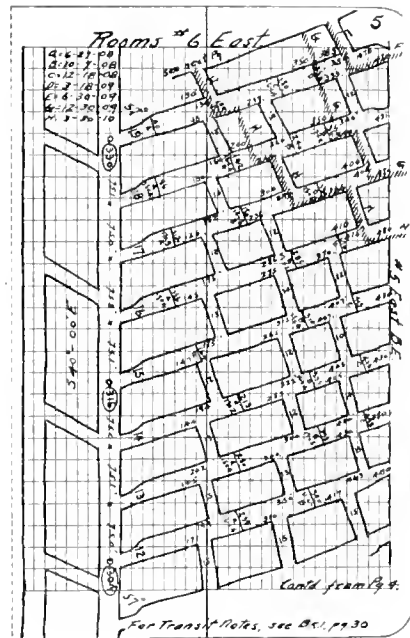

FIG. 2. ROOM BOOK

recorded in an office book probably a hundred or so miles away. The books required for this system are: the entry books Fig. 1, room books, Fig. 2; and an office copy of both entry and room books copied from them and kept in a safe place, only for use in case the field books should become destroyed or lost.

In the entry books, column one is used for the station number, also the profile +. The station number is stamped on a miners' brass check and fastened on the survey plug with the same spad to which the engineer takes his sight.

On the line between columns one and two is recorded the vertical angle and slope distance. The difference of elevation, and horizontal distance are recorded on the opposite side of the line, when calculated in the office.

Column two is used for the deflection angle, whether right or left, column three for the calculated course, column four for the magnetic course, column five for the latitude, and column six for the departure. The elevation as calculated from the vertical angles is recorded on the opposite side of the page.

Where a tie is made the error in chaining is shown by recording the latitude and departure, as calculated from parallel entry survey, under the latitude and departure of the survey station to which the tie was made.

In taking the room notes the distance between rooms on the entry is carefully measured and recorded, also the angle at which the rooms are turned off the entry is recorded at one or more places. The rooms measurements are made from the survey line on the entry and all cross-cuts right and left are located by measurement, a small dot in the notes showing the point measured too.

At the time of each quarterly survey the engineer takes sights in the rooms by hanging plumb bobs on the sight spads, and measurements are taken from either side of this sight line to the ribs. The width of cross-cuts is also recorded.

While the room is advancing, the distance to the cross-cuts and face is recorded, along with the width of the room and the survey letter, inside the room on the sketch. When the room pillars are being pulled the distance from the entry to the gob line is recorded on the pillar to the left of the room in which the measurement was taken. This avoids any confusion between the old and new figures.

As in the entry notes the date of each survey letter is recorded on each page.

The index for the room notes is merely a matter of indexing each entry in consecutive order as they are found in the book.

Coal Mine Shaft Pillars

Proportioning According to the Compressive Strength of the Coal of Which They Are Made

It is believed that William Griffith, E. M., of Scranton, Pa., first suggested the proportioning of mine pillars according to the compressive strength of the coal of which they were made. To carry out his ideas the Scranton Engineers' Club, in 1900, appointed a coal-test committee who reported in 1903. While their investigations were not entirely satisfactory, they were at least in the right direction and were worthy of a more general and thorough discussion. Joseph Daniels and S. D. Moore of Lehigh University took up the subject as a thesis, and their deductions differed materially from those of the Scranton Engineers Club committee, and while not entirely satisfactory, were another step in the right direction.

In discussing the strength of coal and the proportioning of shaft pillars according to that strength, it is necessary to go somewhat into the literature on the subject. A writer says: "It is impossible to give exact rules or formulas for determining the size of pillars. Each case in practice requires special consideration, and in laying out mine pillars in a virgin field it is well to find out what the current practice is in similar fields."

This writer is correct when he says each mine requires special consideration, but is it not illogical to advise one to go into another field to find out a matter that requires special consideration at each mine, no two being the same in any one field? The rule of thumb suggested is equivalent to using a ton of iron where 500 pounds would answer, and such practice involves no engineering skill. As a practical example of the variation in the strength of coal, tests made with 2-inch cubes of anthracite from the Lehigh field withstood 4,500 pounds pressure per square inch before the first crack appeared and 5,400 pounds before crushing. On the other hand a 2-inch cube from the Lackawanna field failed at 1,500 pounds per square inch and crushed at 2,182 pounds. This comparison between one of the strongest and one of the weakest coals in the two fields shows that each mine is a problem in itself.

The difference in compressive strength is not so remarkable to those who know the degrees of metamorphism which prevail in the different anthracite fields. Following the leader has caused great loss in the past, and "hindsight" has not been as beneficial in coal mining as it might have been had each mine not offered a problem and frequently several problems by itself. If this statement be true, then it is not within the province of the mining engineer to hunt for the proper sized pillars in other fields. The mechanical engineer uses no such tactics, neither does the civil engineer, but both base their work on the strength of materials, and calculate accordingly. Taking the average specific gravity of coal rocks at 2.5, one cubic foot would weigh 156.25 pounds, and prism 1 square inch base and 12 inches high 1.085 pounds. For calculation, assume that the coal rocks have a pressure of 1 pound per square inch for every foot in depth or that the pressure per square foot is $p = 150d$. The squeezing is not the maximum crushing strength but the point where the first crack occurs, and will be greater for soft tough coal than for soft weak coal. According to our formula the depth at which mining must cease in the Lehigh coal would be less than 4,500 feet below the surface, while in the Lackawanna field it would be less than 1,500 feet below the surface. Where insufficient coal is left in pillars a squeeze is brought on and the coal snaps and cracks without crushing at once. The strength of coal has not all to do with the size of pillars; for instance, soft floors require large pillars to prevent creep, and weak roofs require small rooms in order to obtain support from more numerous pillars; however, the proportioning of pillars and rooms is not the subject of this article, and, as T. Lawson would say, the foregoing is preliminary to reaching the system.

Several formulas for shaft pillars have been advanced that on comparison show a difference in size varying from 4,356 square feet to 90,000 square feet for a depth of 300 feet, and from 8,649 square feet to 360,000 square feet for a depth of 600 feet. To further mystify the reader the authors as a rule fail to furnish data to explain how they have deduced the rules they advance. Andre says: "Up to 450 feet in depth shaft pillars should be 105 feet square and for greater depths an increase of 15 feet on each side for every 75 feet of increased depth." According to our assumption, at 450 feet depth the pressure would be 450 pounds, and at $450 + 75 = 525$ feet depth the pressure would be 525 pounds per square inch. If then a pillar 105 feet square can withstand the pressure at 450 feet, the size of the pillar required at 525 feet depth would be $450 : 525 = 105 : 122.5$ square feet which agrees closely with Andre.

Dron's plan for determining the size of shaft pillars is to "draw lines enclosing all surface buildings that it is necessary to erect about the head of a shaft, and make the shaft pillar so that solid coal will be left outside these lines all around for a distance equal to one-third the depth of the shaft." This rule would furnish sufficiently large pillars and make the underpinning to houses in the anthracite cities safer, as it would virtually prevent mining in Scranton, Wilkes-Barre, and other places, therefore this plan seems to be perfunctory.

Hughes tells the reader to "leave 1 foot in width of pillar for every 1 foot depth of shaft." A shaft 450 feet deep would have a 450-foot-square pillar containing 202,500 square feet while Andre's pillar for this depth contained 11,025 square feet. Hughes' rule therefore also seems perfunctory.

Wardle says: "Shaft pillars should not be less than 40 yards square (120 feet square) down to a depth of 60 fathoms (360 feet) and should increase 10 yards on a side for every 20 fathoms increase in depth."

Since the pressure is 360 pounds per square inch at 60 fathoms, it would be 450 pounds at 75 fathoms and the size of the pillar at the latter depth would be $360 : 450 = 120 : 150$ feet square. According to Wardle's rule this pillar should be 142.5 feet square.

Pamely furnishes the following rule: "Allow a pillar 120 feet square for any depth less than 300 feet; for greater depths increase the pillar 15 feet for every 60 feet in depth."

Since the pressure is 300 pounds at 300 feet depth, at 450 feet the pillar should be $300 : 450 = 120 : 180$ feet square; according to Pamely's rule however the pillar would be 157.5 feet square. The discrepancy increases with depth in Pamely's rule.

Merivale gives a formula for shaft pillars which is $S = \sqrt{\frac{D}{50}} \times 22$, in which S = length of the side of the pillar in yards and D equals the depth of the shaft in fathoms. He does not state what the constants 50 and 22 represent. Assume two shafts 300 and 450 feet deep, then according to this rule the pillars would be, respectively, 66 feet square and 81 feet square. If a pillar 66 feet square is able to support a pressure of 300 pounds per square inch then it should be 99 feet square to support a pressure of 450 pounds per square inch.

The sizes of shaft pillars derived by the rules of the various authorities at 300-, 450-, and 600-foot depths are as follows:

Authority	Depth 300 Feet	Depth 450 Feet	Depth 600 Feet
Merivale.....	66 ft. sq.	81.0 ft. sq.	93 ft. sq.
Andre.....	105 ft. sq.	120.0 ft. sq.	140 ft. sq.
Wardle.....	120 ft. sq.	142.5 ft. sq.	200 ft. sq.
Pamely.....	120 ft. sq.	157.5 ft. sq.	240 ft. sq.
Hughes.....	300 ft. sq.	450.0 ft. sq.	600 ft. sq.

Nothing is said by these writers concerning the excavations that must be made in these pillars for the shaft and its underground approaches. Taking Andre's pillar of 105 feet square at 300 feet depth, assume that it will withstand a pressure of 300 pounds per square inch, and assume that the shaft is

10×20 feet or 120 square feet in area, and the underground approaches through the pillar are 10 feet wide. The pillar without excavation would cover an area of 11,025 square feet and this would sustain a pressure 45,000 pounds per square foot. After the shaft and the entries are excavated the pillar will be reduced 1,250 square feet, thus leaving 9,775 square feet to support the pressure formerly sustained by 11,025 square feet; that is, the pressure has increased on the pillar to 9,775 : 11,025 = 45,000 : 50,754 pounds per square foot. Under such conditions, if the squeezing strength was 300 pounds per square inch the safety limit would be passed by making the excavations.

It becomes evident from the calculations that the size of shaft pillars is not to be based on any rule, but on the squeezing strength of the mineral that must sustain the pressure after excavations have been made. Naturally with such great differences in the rules advanced for shaft pillars, which were probably based on the author's experience in some one particular field, the mining engineer must have great faith in his authority to follow him, and it appears to be safer for him to follow the leader whom he knows than the authority he does not know.

來 來

Steel Mine Timbers in the Dodson Colliery

By R. B. Woodworth*

The Dodson colliery of the Plymouth Coal Co. is noted as the place at which culm flushing was first tried out, in 1891, by Gilbert Jones, general superintendent, under the direction of Mr. John C. Haddock, now president of the company.

The timbering in the pump room of this colliery has been a matter of difficulty owing to movement of the strata above it. The original wooden timbering consisted of 18-inch to 22-inch round sticks of white pine, yellow pine, and oak placed 2 feet center to center. A great deal of trouble was experienced from these timbers becoming forced in close upon the pipe lines with the possibility of breaking them. As new timbers were placed, they were put in between the sets already in, so that eventually the pump room had timbers practically skin to skin. It is estimated that the entire pump room was retimbered in wood once a year.

The pump house is 100 feet long, 8 feet high in the clear,



WOOD TIMBERING

and 18 to 22 feet wide. Beginning with April 16, 1910, the 70 wooden sets of mine timbers were replaced by 48 steel sets made up of 18-inch, 55-pound, and 20-inch, 65-pound I-beam collars and 6-inch H-beam legs, weighing 23.6 pounds per foot. The last set was installed about December 15, 1910.

From the statement below it will be noted that the total cost for timbering once with wood was \$2,415, and the total cost for timbering in steel \$2,889.09, or a difference in first cost of not quite 20 per cent. The steel cost at the mines slightly over two and a half times the cost of the wooden sets, and it also



STEEL TIMBERING

cost 33½ per cent. more for placing. Fewer sets were required, however, and the ultimate rate was thereby lessened.

The comparative cost of the two installations is shown in the statement below, prepared by Mr. Haddock:

WOOD	
Number of sets	70
Average diameter of timber, inches	20
Quality of timber—yellow pine and oak	
Average weight per set, pounds	4,150
Cost per set f. o. b. cars mines	\$12.00
Cost per set for placing	\$22.50
Cost per set in place	\$34.50
Total cost for timbering	\$2,415.00
Life of timber set, year	1
STEEL	
Number of sets	48
Size of collars, 18-inch beam, pounds	55
Size of collars, 20-inch beam, pounds	65
Size of legs, 6-inch H-beam, pounds	23.6
Quality of steel—structural grade	
Average weight per set, pounds	1,483
Cost per set f. o. b. mines	\$31.47
Cost per set for placing	\$30.00
Cost per set in place	\$61.47
Total cost for timbering	\$2,889.09

The higher cost of placing the steel is due to three causes:

1. The charge of taking out the old timber, which, however, was insignificant, as the steel was placed a set at a time by forepoling ahead, the condition of the roof being very bad and there being loose material for an unknown distance above.
2. Great care was taken with the steel to line it up properly and provide a good base, which was made of a solid concrete wall built the full length of the pump room on each side. This solid concrete base is unnecessary with the wood and might have been omitted with steel, but its use means a real betterment in the construction.
3. The steel was placed without interfering with the operation of the pumps, which necessitated very careful handling and added something to what the expense would have been had the room been free from obstructions.

It is apparent that while the first cost of the steel construction is greater than that of wood, it will have much more than paid for itself if its life extends over 15 months only, and that every additional length of time it stands will mean that much less in cost of maintenance. The first steel has now been in place 16 months with no sign of deflection in the collars, and what is better, with no evidence of fracture in the concrete where any overloading of the steel would immediately show.

* Carnegie Building, Pittsburg, Pa.

The Cost of Mining Coal in Iowa

Total Wage Cost and Itemized Costs Per Ton From Figures for Three Years, 1907 to 1910

By Edward A. Sayre, E. M.*

The following is a synopsis of a thesis entitled "The Cost of Mining Coal in Iowa," based on the actual cost of mining at the Eagle No. 2 mine, located at Des Moines, Iowa.

The Eagle No. 2 was sunk in the summer of 1907. The cost tables cover the first three years of the mine's life, namely, November 1, 1907, to April 1, 1908; April 1, 1908, to April 1, 1909, and April 1, 1909, to April 1, 1910. The tonnage during those periods was as follows: 9,774, 21,692, and 28,376 tons of lump. As the coal hoisted is composed of approximately 70 per cent. lump and 30 per cent. steam, the total hoist of mine-run coal would be 43 per cent. greater than the above figures. 75 per cent. to 80 per cent. of this tonnage was hoisted during the 7 months from September 1 to April 1, the mine running but part time on a small output the remainder of the year. During the height of the season, the mine hoisted from 150 to 200 tons of lump per day. The entire output was sold locally in Des Moines, Iowa.

The Eagle No. 2 is operated on the room-and-pillar system of mining. Eight-foot or 12-foot entries are driven with 22 feet of pillar between them. Rooms are turned off the side entries with 8-foot room necks 12 feet in length. The rooms are widened to 23 feet and driven in for 150 to 175 feet. Twelve feet of pillar is left between rooms. The coal varies in thickness from 3 feet 6 inches to 7 feet 4 inches, the average being 4 feet 6 inches to 5 feet. The mine is dry, no pumps being put below for 1 year after sinking.

The mine is located in subdistrict No. 3, all the mines of this subdistrict being operated under union agreement with the United Mine Workers of America. During the above periods of time, the following scale of wages was paid:

Lump per ton.....	\$1 00
Mine run per ton.....	.69
8-foot entry per yard.....	1.97
12-foot entry per yard.....	1.91
Room turning.....	5.04
Brushing (top or bottom) per inch of thickness per yard of advance of the room or entry.....	.05½
Drivers, timbermen and daymen, per day.....	2.56
Top labor, per day.....	1.90

The following tables are all based on the hoist of lump coal. To find the cost of a ton of mine-run, the results should be multiplied by .7.

Under the above scale of wages, the total wage cost was found to be as follows:

TABLE 1. TOTAL WAGE COST OF MINING

Date	Hoist	Wages	Cost Per Ton
1907-1908.....	9,774	\$15,658.68	\$1.602
1908-1909.....	21,692	36,876.38	1.700
1909-1910.....	28,376	48,437.44	1.707

In the following tables, the total wage cost (Table 1) is divided into the total wage cost below ground (Table 2), and the total wage cost above ground (Table 3).

TABLE 2. TOTAL WAGE COST BELOW GROUND

Date	Hoist	Wages	Cost Per Ton
1907-1908.....	9,774	\$13,974.11	\$1.430
1908-1909.....	21,692	33,100.53	1.540
1909-1910.....	28,376	44,320.28	1.561

* From the Iowa State College Engineer.

TABLE 3. TOTAL COST ABOVE GROUND

Date	Hoist	Wages	Cost Per Ton
1907-1908.....	9,774	\$1,684.57	\$.172
1908-1909.....	21,692	3,475.85	.160
1909-1910.....	28,376	4,117.16	.145

In explanation of Table 3, the method of handling coal on top is as follows: The coal is hoisted, weighed, dumped on two platforms, and from thence loaded into wagons by teamsters. The wage cost above ground includes the wages of dumper, helper, two platform men, a top boss, engineer, night watch, and blacksmith.

The total wage cost below ground (Table 2) is divided into the Wage Cost to Miners (Table 4) and the Wage Cost to Day Men Below Ground (Table 5).

TABLE 4. TOTAL WAGE COST TO MINERS

Date	Hoist	Wages	Cost Per Ton
1907-1908.....	9,774	\$12,397.61	\$1.268
1908-1909.....	21,692	28,676.08	1.322
1909-1910.....	28,376	36,326.64	1.280

TABLE 5. TOTAL WAGE COST TO DAY MEN BELOW GROUND

Date	Hoist	Wages	Cost Per Ton
1907-1908.....	9,774	\$1,576.50	\$.161
1908-1909.....	21,692	4,724.45	.218
1909-1910.....	28,376	7,993.64	.282

The total wage cost to miners (Table 4) is further divided as follows:

TABLE 6. TOTAL WAGE COST TO ROOM MEN

Date	Hoist	Wages	Cost Per Ton
1907-1908.....	6,987	\$ 7,814.80	\$1.118
1908-1909.....	14,190	16,657.94	1.174
1909-1910.....	22,466	26,311.72	1.171

TABLE 7. TOTAL WAGE COST TO ENTRYMEN

Date	Hoist	Wages	Cost Per Ton
1907-1908.....	2,787	\$ 4,582.81	\$1.644
1908-1909.....	7,501	12,018.14	1.602
1909-1910.....	5,909	10,014.92	1.694

These tables show that during the first year 71 per cent. of the coal came from rooms and 29 per cent. from entries (development work); the second year 65 per cent. and 35 per cent., and the third year 79 per cent. and 21 per cent., respectively. They show an additional cost of approximately 50 cents per ton for entry coal compared with the coal obtained from rooms.

The wage cost to day men below ground (Table 5) is divided into the wage cost of haulage (Table 8) and the wage cost of all other day men below (Table 9). This latter table includes the wages of pit boss, timbermen, dirt men, trackman, cager, and trapper. The haulage was done entirely by mules.

TABLE 8. TOTAL WAGE COST OF HAULAGE

Date	Hoist	Wages	Cost Per Ton
1907-1908.....	9,774	\$ 585.60	\$.060
1908-1909.....	21,692	1,625.04	.075
1909-1910.....	28,376	2,644.01	.093

TABLE 9. TOTAL COST OF ALL OTHER DAY WORK BELOW

Date	Hoist	Wages	Cost Per Ton
1907-1908	9,774	\$ 990 90	\$.101
1908-1909	21,692	3,069 41	.143
1909-1910	28,376	5,349 63	.188

As 75 to 80 per cent. of the coal is hoisted during the 7 months, from September 1 to April 1, the wage cost is much less during that time than during the summer. In fact, there is a severe loss in all local mines during the summer owing to the small output. To show the increased cost during the summer time, Table 10 is appended:

TABLE 10. COST OF DAY WORK, SUMMER AND WINTER

	Haulage	Other Day-Men	Total Below	Total Above	Total Day Work
November, 1907, to April, 1908060	.101	.161	.172	.334
April, 1908, to September, 1908106	.217	.323	.249	.572
September, 1908, to April, 1909068	.127	.195	.141	.336
Average for year075	.143	.218	.160	.378
April, 1909, to September, 1909102	.295	.397	.258	.655
September, 1909, to April, 1910091	.161	.252	.116	.369
Average for year093	.188	.282	.145	.427

From the above it is seen that the day wage cost is approximately 30 cents per ton more in summer than in winter.

For the purpose of comparison with other mines, Table 11 is added showing the detailed cost of Tables 1, 6, and 7:

TABLE 11

Year	Coal	Extras	Yardage	Day Work	Room Turning	Total
1907-1908						
Total to miners	1.00	.034	.212	.015	.006	1.268
Room men	1.00	.018	.072	.019	.009	1.118
Entrymen	1.00	.076	.564	.004		1.644
1908-1909						
Total to miners	1.00	.043	.255	.016	.008	1.322
Room men	1.00	.028	.121	.013	.012	1.174
Entrymen	1.00	.070	.510	.022		1.602
1909-1911						
Total to miners	1.00	.025	.208	.038	.009	1.280
Room men	1.00	.021	.104	.035	.011	1.171
Entrymen	1.00	.039	.606	.049		1.694

The cost of coal from 12-foot entries for the 3 years was as follows: \$1.612, \$1.639, and \$1.693, respectively. The cost of coal from 8-foot entries for the 3 years was as follows: \$1.731, \$1.475, and \$1.760. The surprising shrinkage in the cost of 8-foot entries during the second year was due to the fact that several hundred feet of 8-foot entries were driven in thick coal (6 feet or over) during that time. The average thickness of top or bottom removed for height in the 12-foot entries were 17.5, 15.1, and 21.1 inches during the three years.

The second part of the thesis takes up the costs of operation of the mine. Among them are the following: Royalty, \$.135; timber, \$.037, \$.057 and \$.076 for the 3 years, respectively; wooden ties and trackage, \$.016, \$.018, \$.016; water for boilers (purchased from the Des Moines Water Co.), \$.008, \$.006, \$.005; liability insurance, \$.016, \$.012, \$.010. The larger costs of operating, namely, expense of management, repairs and depreciation, amortization, interest on capital invested, shrinkage, taxes, and cost of power, are treated at length in the thesis, but space prevents their proper discussion in this synopsis. It may be stated, however, that these costs make up a considerable proportion of the total cost of mining coal.

The third part of thesis considers the selling expense of the business, namely, advertising, bad accounts, rents, salaries of clerks and incidentals.

In conclusion, the writer desires to state that the mining costs at the Eagle No. 2 should bear some definite relation to the costs at the other mines in the district. This should be

especially true of the wage cost of mining. Undoubtedly, there are small variations but the totals should not be far apart. It has been the thought of the writer that if the operators of this district should compare their cost tables, they could, without question, effect a saving in their mining expense by each one adopting for his own use the particular systems that have been tried out and found most profitable in the other mines.

采 采

Stock Pile Fires

Where it is necessary to stock bituminous coal for winter use or to guard against shortage, it is customary to take precautions against fire. Bituminous coal should not be piled in

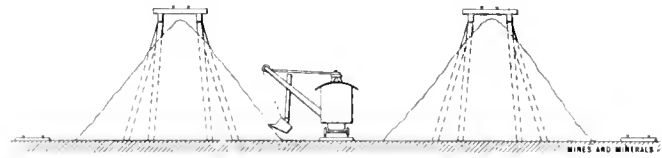

Fig. 1

heaps exceeding 20 feet and these heaps should not be continuous in breadth, so that in case of fire steam shovels can be put to work at once to dig out the fire. The piles should be arranged as shown in Fig. 1 and may have indefinite length.

When coal is stocked in this way chances for heating to the point of ignition by oxidation are lessened.



Fig. 2

In case steam shovels are not available or are not warranted by the size of the stock pile, a fairly sure method of extinguishing the coal in case it should catch fire is to drive pipes perforated with small holes, as in Fig. 2, down to the bottom of the pile where the fire is located, and then attach the pipes to a pump and force water through them. The futility of endeavoring to put out a coal fire by throwing water on the pile is due to only a portion of the water reaching the fire owing to its going in other directions mostly, being converted into steam before it reaches the fire, or if the steam reaches the fire it probably is dissociated and provides hydrogen and oxygen for combustion. By the use of these pipes the water reaches the fire in such a manner as to cool down the pile and put out the fire if it has not extended too far.

The readers of MINES AND MINERALS are indebted to H. D. Conant, superintendent of the Lake Superior Copper Smelter, for this wrinkle. He has had occasion more than once to effectively put out a coal-pile fire by the use of one or both of these devices.

采 采

Institute Meetings

The winter meeting of the Coal Mining Institute of America will be held in Pittsburg, Pa., at the rooms of the Engineers' Society of Western Pennsylvania, December 19, 20, and 21. The Institute will meet in joint session with the Engineers' Society one day or evening as the guests of the Society. Papers to be presented before the Institute should be sent to C. L. Fay, Wilkes-Barre, Pa., who is secretary of the Institute. The program for the meeting will be announced later.

The next annual meeting of the Gas and Gasoline Engine Trades Association will be held at Hotel Hollenden, Cleveland, Ohio, December, 5, 6, 7, and 8. Albert Stritmatter, secretary, Cincinnati, Ohio.

The winter meeting of the West Virginia Mining Institute will be held in Fairmont, W. Va., in December. All communications to the Institute should be addressed to E. B. Day, secretary, 108 Smithfield St., Pittsburg, Pa.

Coal Dust

The Influence of Compression, Percussion and Detonation in Causing and Transmitting Explosions

By James Ashworth

There is one topic connected with coal mining which never seems to wear out, viz., that of coal dust, and although governmental commissions, committees of mining societies, and many mining men have investigated and experimented, yet very frequently a recrudescence of the subject comes along and rouses some section of its mysteries into active life. Thus the publication of the report of the First Series of the British Coal-Dust Experiments, which were made at the expense of the Mining Association of Great Britain; the French Government's experiments at Lievin; and the Austrian Government's experiments, have all added something to our knowledge. Many explosions in the United States, a few in Canada, and some also in England, have demonstrated forces and effects, the sequence of which is a subject on which leading authorities are widely divided. One need only to take up any issue of MINES AND MINERALS for several months past, to find this fact amply substantiated; for instance, in the September issue, there is the report of a discussion by some members of the Institution of Mining Engineers

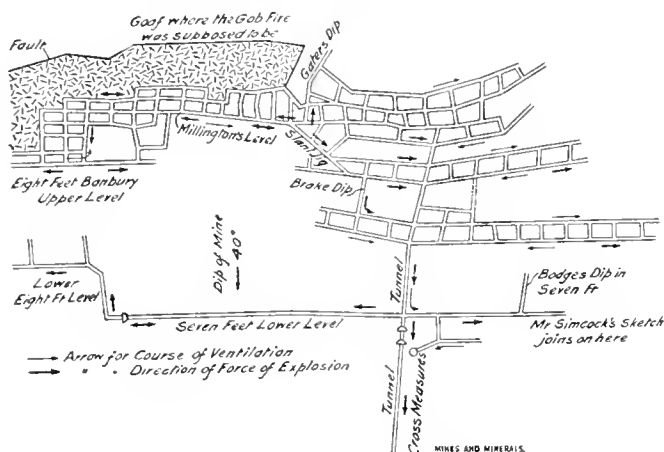

FIG. 1

in England, on "Coal Dust and Zone Systems," the original paper having been written by Mr. E. O. Simcock, who, if the present writer is not mistaken, was the patentee of a protective dust-zone system, and therefore his present writing goes to show that he no longer considers a zone of incombustible dust of any practical value in preventing or controlling the flame of a coal-dust explosion.

For many years the writer has persistently opposed the notion that spraying, dampening, or watering roadways, is of any practical value in controlling the extent of an explosion, after it has once been originated. It may also be remembered by some of your readers, that he has also shown that no system of "zones" can control a present-day explosion in a mine where there is firedamp, as well as coal dust because the effect of compression, percussion, and detonation must all be taken into account. Very few mining men have as yet acknowledged the influence of either or any of these factors, and therefore the unbelievers ought to take particular notice of the following quotation from page 150 of the Report of the British Coal-Dust Experiments committee: "The indiscriminate use of the word 'detonation' as applied to explosion having resulted in some confusion, Prof. H. B. Dixon has kindly contributed the following note, in which, as the originator of the term 'detonation wave' he explains its significance. It is of course quite permissible to speak of an explosion as being accompanied

by a loud detonation—signifying a loud noise; but it is probable that by use in this way the wrong application has arisen. The important question to decide is whether the 'detonation wave' (explosion wave) can be developed by the explosive combustion of a gas or of coal dust.

"The expression 'L'onde Explosive,' coined by Berthelot, and its English equivalent, 'The Explosion Wave,' signify that flame which passes through a uniform gaseous mixture with a permanent maximum velocity. The rate of the 'explosion wave' is a definite physical constant for each mixture; the 'explosion wave' travels with the velocity of sound in the burning gas which itself is moving rapidly forward en masse in the same direction, so that the explosion 'wave' is propagated far more quickly than sound travels in the unburnt gas.

"When an explosive mixture is fired by a spark or flame in a long tube, the flame is usually propagated along the tube with an increasing velocity until, at a certain distance from the ignition point (according to the nature of the gases), the 'explosion wave' is set up—if this can be propagated through the mixture.

"The firing of a fulminate in such a mixture sets up the 'explosion wave' at once.

"In other mixtures the 'explosion wave' cannot be set up under ordinary conditions, e. g., in mixtures of firedamp or of coal gas and air. In these cases the flame is propagated irregularly or with vibratory oscillation, and the flame is sometimes spontaneously extinguished. Whereas the pressure in the 'explosion wave' is constant, it is quite irregular in 'vibratory' explosions.

"In the 'explosion wave' each layer of gas is compressed so suddenly that it is raised beyond its ignition point by the heat of compression, and in burning it compresses in turn the unburnt layer in front of it. The chemical combustion is much more intense and rapid than in the ordinary flame of explosion, and as a result the gases cool much more quickly behind the 'explosion wave.'

"I use the word 'detonation' to express the burning taking place in the 'explosion wave,' since a detonator when struck burns in this way itself and sets up an explosion wave in explosive gases round it."

In MINES AND MINERALS for December, 1908, Vol. XXIX, page 238, Fig. 6, is a reproduction of a photograph of a "double explosion" at the downcast end of the Altofts Testing Gallery, Experiment 21, and to the writer's mind this may be accepted as a graphic demonstration of the opinion of Professor Dixon when he penned the concluding paragraph of the note quoted above.

During the Altofts experiments there were at least two other demonstrations which the writer believes to have been detonations, viz., Nos. 13 and 25.

What the writer wishes to draw particular attention to, is the stern fact, that if compression, percussion, or detonation, have the effects which he believes they have in propagating an explosion of mixtures of air, firedamp, and coal dust, then it is useless to spend so much energy in arguing about the value of zones, without such zones can be made to negative those effects which at present ignore or jump across them, and thereby render them useless.

It is regrettable that the plans of parts of the Blackwell and of Talk o' the Hill collieries should give such very limited information; for instance, the explosion at the latter colliery was not in the part shown (which is a portion of the Seven Feet Banbury), but in the Eight Feet Banbury, Fig. 1, and there were also other influences bearing on direction and extent of the explosion flame and force. For instance, the main force was expending itself in the Eight Feet Banbury and in the opposite direction to what it was in the Seven Feet mine, viz., outwards toward the shaft, and the influence stated in the last paragraph but one of Professor Dixon's notes might also have been exerting an important effect.

The writer would also call the attention of those who think that detonation or some such effect is not demonstrated in what is now known as a coal-dust explosion, to the report on the experiments at Lievin. The average rate of the speed of the coal-dust flame was 500 feet per second along a gallery 750 feet long, but it was found that near the mouth of the gallery the velocity increased very suddenly up to 3,300 feet per second, and that the consequent high pressure was created almost instantaneously, viz., in .02 part of a second.

On one occasion about 30 feet of the end of the gallery was destroyed and blown away, although its static bursting pressure was 570 pounds per square inch, and one end open to the atmosphere.

This effect was similar to that demonstrated in experiments Nos. 13 and 25, at Altofts, and all three require more elucidation than they have yet received.

The underground experimental gallery at Pittsburg offers very suitable conditions for the investigation of these great pressures if the roadways are of sufficient length. The writer is absolutely certain that the actual speed of an explosion is very greatly underestimated, and that the "pioneering" cloud of dust is not a factor in extensive colliery explosions.

The issue of MINES AND MINERALS for September also shows that "double explosions" occur under very ordinary conditions, and moreover are not uncommon, and therefore that this subject requires a great deal more attention than it has heretofore received.

There is one other point, which although it does not perhaps directly affect the question of detonation, yet is almost invariably found in the neighborhood of the place of origin of a large colliery explosion, and it is that of a considerable free air space, such as the entry to an adjoining roadway, or a large cavity in the roof. This assumption is supported by the demonstrations at Altofts. If in the underground experimental gallery at Pittsburg, such a space is provided, it will add immensely to our knowledge of how coal-dust explosions are propagated.

Detonative blasting has displaced the old way of igniting a charge of explosive, but the writer has no hesitation in saying that it has unfortunately introduced another danger which is doubly dangerous, because its existence is not recognized.

Personal

J. A. Burgess is in charge of the Nevada Wonder mine, Wonder, Nev.

F. G. Cottrell has been appointed by the Bureau of Mines to take charge of a special investigation of the smelter-fume problem.

Waldemar Lindgren, of the United States Geological Survey, will soon commence the work of bringing the study of the geology of the Tintic district up to date.

William Fleet Robertson, provincial mineralogist for British Columbia, has been examining the Hazleton mineral district in the Skeena River country.

E. N. Zern has resigned as superintendent of No. 8 mine of Jamison Coal and Coke Co., to accept the assistant professorship of coal mining at the University of Pittsburg.

J. C. Roberts, engineer in charge of Mine Rescue Car No. 2, returned to Trinidad September 11. It is reported that Mr. Roberts will make his headquarters in Denver and have charge of both cars No. 2 and No. 4, at Trinidad, Colo., and Rock Springs, Wyo., respectively, joining either as emergencies may require.

John Arnott has been appointed superintendent of the Crested Butte mine and ovens, and of the Floresta anthracite mine of the Colorado Fuel and Iron Co., vice Robert McAllister, whose resignation was noted in October.

Sumner S. Smith, formerly in charge of Mine Rescue Car No. 4, whose departure for Alaska has been noted in this

column, has been appointed United States Mine Inspector for that territory. Mr. Smith's headquarters are not yet certain, but will probably be very largely "in the saddle."

H. H. Sanderson, of Danford & Sanderson, mining engineers, has returned to Trinidad after an extended trip throughout the West. While in Nevada he used the oxygen helmet apparatus familiar to our coal readers at the fire in the shaft of the Giroux Consolidated Mines Co., Kimberly, and had some interesting experience with the same on the 2,250-foot level of the Ward shaft, Nevada City, where the temperature is 155 degrees.

Geo. R. Delamater, formerly in charge of the United States Bureau of Mines coal-testing station, at Denver, is practicing his profession, with office at 1710 Glenarm St. As in the past, Mr. Delamater is making a specialty of coal-washing methods and machinery.

J. V. N. Dorr, metallurgical engineer, 709 Equitable Building, Denver, has been appointed manager of the Mogul Mining Co., Pluma, S. Dak.

C. W. Henderson, statistician, United States Geological Survey, Denver, spent September and October in the field near Central City, Colo.

W. J. Murray, vice-president and general manager Victor-American Fuel Co., returned to Denver, October 15, after an extended trip to the Pacific coast.

G. W. Evans, who recently visited Alaska coal fields with Secretary Fisher, has returned to the fields in the interest of the Bureau of Mines.

G. A. Goodenough, of the University of Illinois, has been promoted from Associate Professor of Mechanical Engineering to Professor of Thermodynamics.

F. C. Lincoln, S. B., Massachusetts Institute of Technology, 1900; E. M., New Mexico School of Mines, 1904; A. M., Columbia University, 1906, Ph. D., 1911; for 3 years Professor of Geology and Metallurgy at the New Mexico School of Mines, for 3 years Professor of Geology at the Montana State School of Mines, and for the past year in practice in New York City as consulting mining engineer, has been appointed Associate Professor in Mining Engineering at the University of Illinois.

Arthur Lakes, Jr., mining engineer, of Denver, has taken charge of the Ymir-Wilcox Development Co.'s mines at Ymir, B. C.

Joseph T. Berry, Jr., E. M., formerly of Butte, Mont., is now superintendent of the Dan mine, near Baker, Ore.

Wm. H. Armstrong, former mill superintendent for the Dos Estrellas Mining Co., El Oro, Mex., is connected with the Mexico Mine and Smelter Supply Co., at Mexico City.

O. E. Jager, former assistant superintendent at the Velardena smelter, in Mexico, has been appointed assistant superintendent of the Cerro de Pasco smelter in Peru.

F. M. Chase, assistant to S. D. Warriner, Vice-President and General Manager of the Lehigh Valley Coal Co., was on October 1 appointed General Superintendent of the company, with headquarters at Wilkes-Barre, Pa. The promotion follows faithful service for years on the part of Mr. Chase, and his advancement is a source of satisfaction and pleasure to the subordinate officials of the company, and all others who have been thrown in contact with him in his former positions.

Dr. M. J. Shields, field representative of the American Red Cross, has started a thorough course in first aid for the H. C. Frick Coke Co. The lectures commenced on September 26, at Latrobe, and the operations of the company were divided into five districts—Latrobe, Mt. Pleasant, Connellsville, Uniontown, and Brownsville. To start with, as a nucleus, about 500 men will be trained, which will be about one out of 30 of the employes.

E. N. Zern, superintendent of the H. C. Frick Coke Co. from 1908 to date, and an experienced mining engineer, has been appointed Assistant Professor of Coal Mining in the University of Pittsburg School of Mines. Mr. Zern is a graduate of Pennsylvania State College, serving as instructor in mining

and mineralogy there for several years before taking up field work. H. B. Meller, a member of last year's faculty of the School of Mines, has been advanced from instructor in mining to assistant professor of metal mining. Mr. Meller studied in the University of Pennsylvania, Michigan College of Mines, and University of Pittsburg, receiving his E. M. degree from the last-named institution in 1910. He has had a number of years practical experience.

來 來

Appointment of H. M. Inspectors

The following rules in regard to the appointment of inspectors of mines in Great Britain have recently been issued by the Home Office, London.

Inspectors of mines and quarries are appointed by the Home Secretary after a competitive examination limited to candidates who are nominated by him. In addition to the chief inspector and the electrical inspector, there are: Divisional inspectors, with salary of £750, rising by £50 a year to £1,000; senior inspectors, with salary of £500, rising by £20 a year to £700; junior inspectors, with salary of £300, rising by £15 a year to £450. The divisional and senior inspectorships are filled by promotion from the rank below and the vacancies for new appointments arise only in the rank of junior inspectors. Application for a nomination to compete for the appointment of junior inspector are made on forms furnished which must be filled up carefully in the applicant's own handwriting and must be accompanied by one or two testimonials, based upon personal knowledge of the candidate, indicating what experience he has had in mines, and giving information as to his character and fitness for the appointment. The form, when filled in, must be returned direct to the Private Secretary, Home Office. Nominations are given only by the Home Secretary, on the advice of a Home Office committee of selection who consider all applications impartially on their merits. No recommendations or testimonials are considered unless based on personal knowledge of the candidate's character and attainments. Candidates are therefore particularly advised in their own interest not to seek political or social influence, which will prejudice rather than assist their candidature. Nominations are only given when an examination to fill a vacancy is about to be held. The attention of candidates is specially directed to this, and to the fact that of the numerous applicants only a very limited number, namely, those who appear, after careful consideration and inquiry, to be the best qualified in every way for the position, can be given the opportunity to compete. It should be distinctly understood, therefore, that any candidate who spends time and money in preparation before he receives a nomination does so at his own risk. Nominated candidates receive not less than a month's notice of the examination. Every candidate must hold a first-class certificate under the Coal Mines Regulation Act, and must, within 5 years previous to his application, have been employed for 2 years as manager or undermanager of a coal mine, or in some other responsible capacity requiring regular attendance underground in a coal mine. An exception to this rule is allowed in the case of subinspectors. Practical knowledge and experience of metalliferous mining and quarrying will also be taken into consideration. The prescribed age for candidates at the time of examination is between 23 and 35 years, but an extension up to 45 is allowed in the case of a candidate who has served as a subinspector, with a certificate of the civil service commissions, from a time when he was under 35. No exception can be made to this rule.

Candidates must qualify in each of the subjects numbered 1, 4, 5, and 6, and must also obtain such an aggregate of marks in all the subjects numbered 1 to 8 taken together as to satisfy the civil service commissioners. Subjects 9 and 10 are optional, and only one of them may be offered. The fee for the examination is £6. A candidate is further required, before he can be

appointed, to satisfy the civil service commissioners as to his character and that his age is within the prescribed limits, and that he is physically fit for the work. An inspector upon first appointment is subject to 2 years probation. He must give his whole time to the official duties assigned to him, and he may be called on to reside in any part of the United Kingdom. Traveling expenses are paid. An inspector's tenure of office, increments of salary, promotion, and pension, are dependent on good conduct and efficient service. Inspectors may be called on to retire at 60 years of age, and retire in any case at 65.

The following are the subjects of examination:

	<i>Maximum of Marks</i>
(1) English.....	400
(2) Elementary mathematics.....	200
(3) Elementary geology.....	200
(4) Coal mining.....	1,000
(5) Ore and stone mining.....	300
(6) Electricity in mines.....	300
(7) Law relating to mines and quarries.....	200
(8) Oral examination.....	400
(9) Chemistry.....	400
(10) Physics.....	400

SYLLABUS

English. Includes composition, the writing of reports and précis writing, but does not include indexing. Attention is paid to handwriting and spelling in this as in other subjects.

Elementary Mathematics. Will include arithmetic, algebra to quadratic equations, plane geometry, plane trigonometry to the solution of triangles.

Elementary Geology. Outlines of physical geology, including the physical characters and chemical composition of rock-forming minerals and the classification and description of rocks; elements of stratigraphy and with special reference to the British Isles; the construction and interpretation of geological maps and sections; the occurrence of coal, stone, and metalliferous minerals.

In this subject there will be a laboratory test in addition to the written test.

Coal Mining—theoretical and practical, including systems of sinking and working, methods of supporting roofs and sides, mechanical engineering applied to coal mining, theory and practice of ventilation, surveying and making of plans, use of explosives, mine gases and their analysis, prevention of accidents, rescue work, and the restoration of mines after explosions and fires. Mining hygiene.

Ore and Stone Mining—theoretical and practical, including methods of sinking and working, methods of supporting excavations, mechanical engineering applied to ore and stone mining, ventilation of metalliferous mines, prevention of accidents. Ore dressing. Mining hygiene.

Electricity in Mines. Installation and use of electricity in mines, including the practical units of measurements and the use of simple measuring instruments; transmission and use of electricity by alternating and direct currents; the construction of cables, and the jointing and testing of cables; earthing; the rules as to the use of electricity in mines and the prevention of accidents.

Law Relating to Mines and Quarries. Knowledge of the coal mines regulation acts, the metalliferous mines regulation acts, the quarries act, and the rules and orders made thereunder.

Oral Examination. Questions may be asked on coal mining, ore and stone mining, and electricity.

Chemistry. The principles of inorganic chemistry and the study of the occurrence, modes of preparation, and properties of the principal elements and their more important compounds. Questions may be set on the chemical principles involved in the commercial preparation of important inorganic substances. Elementary organic chemistry.

In this subject there will, in addition to the written test, be a laboratory test which will include the preparation and analysis of inorganic substances.

Physics. Will include heat, light, sound, electricity, and theoretical and applied mechanics.

In this subject there will be a laboratory test in addition to the written test.

乘
Correspondence
乘

Geometry

Editor Mines and Minerals:

SIR:—The following problem may be of interest to many of your readers:

To prove that the square of the side of a regular inscribed pentagon is equal to the square of the side of a regular inscribed decagon plus 1.

In the accompanying figure, with *O* as a center and radius equal to *CO*, construct a circle as *CBJE*.

Then draw four radii *CO*, *BO*, *JO*, *EO*, 36 degrees apart then the chords *CB*, *BJ*, *JE* will be equal to the length of a side of a regular inscribed decagon, also the chord *BE* will be equal to the length of the side of a regular inscribed pentagon because it is the chord of 72 degrees.

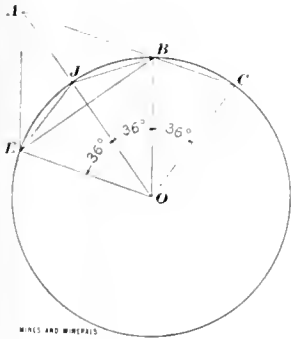

The angles *COB*, *BOJ*, and *JOE* are each equal to 36 degrees, and as the triangles *CBO*, *BOJ*, and *JOE* are each an isosceles, the angles *OCB*, *CB O*, *OB J*, *BJO*, *OJE*, and *JEO* are each equal to 72 degrees.

The angles *CB O + O B J* = 144 degrees.

Then the angle *ABJ* will equal 36 degrees.

But as the angles *ACO + COB + BOA* = 144 degrees, then the angle *OAC* = 36 degrees also; therefore, the triangle *ABJ* is isosceles and the line *AJ* equals the chord *JB*.

Then the triangles *ACO* and *COB* are similar, then are relative sides proportional.

That is *AO : OC :: OC : CB*.

Now if we let *D* equal the side of a regular decagon, and 1 equal the radius of the circle, then the equation becomes

$$1 + D : 1 :: 1 : D \text{ or } D + D^2 = 1. \quad (1)$$

Transposing, $0 = 1 - D - D^2$ (2)

We also find that *AJ + JO = AB + BC*. But *AJ = BC*, then *AB = JO*. Also, *JO = BO = EO*, and *AE = AB*.

Therefore, the figure *ABOE* is a parallelogram and the diagonals are perpendicular to each other. That is, the line *BE* is perpendicular to the line *AO*.

Now let *P* equal the line *BE* or the length of the side of a regular pentagon. Then,

$$\left(\frac{1+D}{2}\right)^2 + \left(\frac{P}{2}\right)^2 = 1 \quad (3)$$

Then $1 + 2D + D^2 + P^2 = 4$
 or $P^2 = 3 - 2D - D^2$
 $0 = 2 - 2D - 2D^2$ (2)
 $P^2 = 1 + D^2$

Q. E. D.
 J. L. McNATT

Watering Dust and Employment of Shot Firers

Editor Mines and Minerals:

SIR:—I see in your September number, on page 66, under the title, "An Historic Mine," you state: "To Mr. Joseph Watson, the superintendent of Como No. 5 mine, at Como, Park County, Colo., and now general superintendent of the National Fuel Co., at Louisville, Colo., must be given the credit of having adopted this system 5 years earlier than the date set by Mr. Rice, viz., May, 1895. It also seems probable that to Mr. Watson is due the further credit of having first employed shot firers in the mines of our country."

"If any of our readers are advised of an earlier date than May, 1895, on which watering of dust was practiced, or shot firers were employed in American mines, we shall be glad to hear from them."

I was appointed State Mine Inspector of Missouri in January, 1889, after a disastrous explosion had occurred in Mine No. 6, owned and operated by the Keith & Perry Coal Co., and located about 4 miles north of Rich Hill, Mo., in which 23 men lost their lives. The explosion took place while shots were being fired. Shortly after I was installed into office a slight explosion took place in one of the Rich Hill Coal and Mining Co.'s mines, in which several men were burned, but none fatally. These accidents, together with others that had recently taken place while shots were being fired, led me to believe that firing shots in certain mines was dangerous to human life and to property, and that the fewer men in such mines when the shots were being fired the better, so I at once wrote to Mr. Newberry, who was the Representative from Bates County, urging him to try and pass a shot-firing law, which I had outlined. The bill was passed at once. This bill required that shot firers be employed to fire the shots after the miners and other employes had retired from the mine. This bill only applied to dusty mines and mines producing light carbureted hydrogen gas. As soon as the law became effective, shot firers were put on at the mines around Rich Hill, Mo. This was in the summer and fall of 1889.

The law proved to be a good measure, for during the next 2 or 3 years no less than four explosions took place in the vicinity of Rich Hill, which would doubtless have cost hundreds of valuable lives had the old method of every man firing his own shots been in practice.

In regard to sprinkling mines with water, G. R. Sweeney, superintendent for the Keith & Perry Coal Co., introduced the system in Mine No. 7, near Rich Hill, in 1891, after an explosion that took place October 7 of that year. He used pipes along certain entries, and hose; also water boxes in other parts of the mine.

I do not know of any shot firers being employed in American mines prior to 1889, nor of sprinkling mines practiced prior to 1891.

C. C. WOODSON

Arbitration in the Southwest

Editor Mines and Minerals:

SIR:—Replying to your inquiry of recent date referring to my appointment as permanent arbitrator for the Southwestern Interstate Coal Operators' Association and the United Mine Workers of America, I beg to say that the appointment was made mutually at the conclusion of a 5-months suspension in 1910. The salary and expenses of the arbitrator are borne equally by both operators and miners. The period covered is for the life of the biennial contract. Full time is devoted to the four states covered by the Interstate District: Kansas, Missouri, Arkansas, and Oklahoma, covering about 35,000 to 40,000 men and involving probably \$30,000,000 of property.

The Arbitration Board consists of the commissioner for the operators or his deputy, and the District President in the district where grievance arises, or his deputy, and your humble servant as permanent arbitrator, and all questions arising under the written terms of the biennial contract or under the customs and usages of the mining industry that are proven to be permanent customs and usages, are matters of mediation and arbitration and in all cases where the representatives of the operators and the United Mine Workers of America are unable to agree, the arbitrator holds a hearing. The case is presented by written briefs, statements, affidavits, or oral evidence, and if either party requires it, personal inspection of the physical properties of the mine or parts of the mine under dispute, after which a written decision is issued by the arbitrator to each side, which is final and binding on all concerned.

The contract provides the penalty of 50 cents per day per man for a strike where the miners are at fault for such strike and \$1 per day per man where the operator is at fault for a slight win or lock-out. A few of such decisions have been considered for strikes of short duration and both operators and miners have complied with the decision in the matter of fines in other directions required under the contract.

It is, I think, conceded by all parties that there are less strikes and shut-downs under this system and more permanent and regular employment than under the old system of "strike and arbitrate afterwards, providing you can agree," and it is further believed that with some slight modifications, we shall have a simple, efficient, and permanent method for the adjustment of disputes and a prevention of the loss of employment and consequent loss of wages, a system which I believe bespeaks for the successful settlement of industrial controversies and if adopted generally would be a guarantee against the interruption of business in all production, transportation, and commercial lines.

W. L. A. JOHNSON

Topeka, Kans.

Watering Mines

Editor Mines and Minerals:

SIR:—I note an editorial in your issue of September in which reference is made to an alleged statement in Bulletin No. 425 of the United States Geological Survey (Bulletin No. 20 of the United States Bureau of Mines) about watering mines with hose and nozzle.

The quotation that precedes the statement in the editorial is correct, but the assertion that follows: "and he gives that date as being the time of the first use of water in laying the dust in American mines," has no basis in fact. If you will examine page 73 of Bulletin 425 of the United States Geological Survey (or page 77 of Bulletin 20, Bureau of Mines) you will not find that there is any statement as to what mines first employed the system of watering by hose and nozzle. The reason for referring to Utah was that it was the first, and I think the only, state in which the law requires systematic use of hose. As far as any individual mine is concerned, I think it would be very difficult to determine where watering by use of hose was first employed in this country.

GEO. S. RICE

Pittsburg, Pa.

來 來

Catalogs Received

ALLIS-CHALMERS Co., Milwaukee, Wis., Bulletin No. 1068, Direct-Connected Corliss Engines, 8 pages; Bulletin No. 1070, Barometric Condensers, Type "B," 12 pages; Bulletin No. 1074, Direct-Current Motors and Generators, Types "H" and "HI," 12 pages; Bulletin No. 1078, Alternating Current Generators, 16 pages; Bulletin No. 1082, Engine-Driven Direct-Current Generators, Types "I" and "IW," 16 pages; Bulletin No. 1083, Direct-Current Motors and Generators, Type "K," 20 pages; Bulletin No. 1211, Feeders for Roller Mills, 4 pages; Bulletin No. 1519, Barometric Condensers, Type "AN," 12 pages.

AMERICAN MOISTENING Co., Boston, Mass., Circular describing Mine Sprayers.

BUFFALO FORCE Co., Buffalo, N. Y., Buffalo Spray Nozzles and Strainers, 15 pages.

CROCKER-WHEELER Co., Ampere, N. J., Induction Motors, 16 pages.

CHALMERS & WILLIAMS, Chicago Heights, Ill., Catalog No. 1, Gold and Silver Mill Machinery, Burt Cyanide Filters, 32 pages.

DE LAVAL STEAM TURBINE Co., Trenton, N. J., Catalog "C," Steam Turbines, Centrifugal Pumps, and other Centrifugal Machinery, 30 pages; Comparative Tests of Large Engine and Turbine-Driven Centrifugal Pumps, 12 pages.

THE DE LA VERGNE MACHINE Co., foot of East 138th St., New York, N. Y., Rimes and Rinkles, 24 pages.

E. I. DUPONT DE NEMOURS POWDER Co., Wilmington, Del., Blasting Supplies, 126 pages; The Sport Alluring, 36 pages.

GENERAL ELECTRIC Co., Schenectady, N. Y., Bulletin No. 4858, Single-Phase Motors, Type RI, 16 pages; Bulletin No. 4864, Hand-Operated Starting Compensators for Alternating-Current Motors, 14 pages; Bulletin No. 4865, Electric Hoists, 12 pages; Bulletin No. 4868, Rotary Converters, 32 pages.

HUGHSON STEAM SPECIALTY Co., 5021-23 State St., Chicago, Ill., Catalog C, Hughson Steam Specialties, 48 pages.

THE HENDRIE & BOLTHOFF MFG. AND SUPPLY Co., Denver, Colo., The Hoist Question, 16 pages; Electric Hoists, 28 pages; Vulcan Steel Frame Electric Hoists, 16 pages.

KANAWHA CHEMICAL FIRE ENGINE MFG. Co., 74 Cortlandt St., New York City, N. Y., The Story of the New Chemical Fire Engine, 32 pages.

LITCHFIELD FOUNDRY & MACHINE Co., Litchfield, Ill., Catalog No. 7, Hoisting and Haulage Engines, 36 pages.

W. MANSFIELD & Co., Engineers, Creewood Buildings, Brunswick St. and Back Goree, Liverpool, Mansfield's Patent Automatic Water Finder, 4 pages.

MESTA MACHINE Co., West Homestead, Pa., Pittsburg Meeting of the American Society of Mechanical Engineers, 23 pages.

PORTABLE ELECTRIC SAFETY LIGHT Co., Newark, N. J., The Hubbell Electric Safety Lanterns for Mines, 8 pages.

J. K. SMIT & ZONEN, Plantage Middenlaan No. 12, Amsterdam, Holland, Brazilian Carbons and Borts, 15 pages.

SERVUS RESCUE EQUIPMENT Co., Newark, N. J., The Dreadnaught Oxygen Mine-Rescue Apparatus, 8 pages.

THE WATT MINING CAR WHEEL Co., Barnesville, Ohio, Catalog "G," Ore Buckets and Skips, 8 pages; Catalog "H," Mine Car Wheels and Axles, 16 pages.

WESTINGHOUSE ELECTRIC AND MFG. Co., East Pittsburg, Pa., Circular No. 1028, Westinghouse Rotary Converters, 24 pages; Circular No. 1190, Westinghouse Engine-Driven Alternating-Current Generators, Type E, 12 pages; Westinghouse A. C. Switchboard Meters, 12 pages; Westinghouse D. C. Switchboard Meters, 12 pages; Watthour Meters, Type C, 12 pages; Watthour Meters, Type OA, for Small Residence Loads, 8 pages; The Westinghouse Electric Tailor's Iron, 12 pages.

HAZARD MFG. Co., Wilkes-Barre, Pa., Specifications Covering Penn New Code Wires and Cables, 14 pages; Specifications Covering Hazard 30 per cent. Para, and Keystone 25 per cent. Para, Wires and Cables, 20 pages.

McKIERNAN-TERRY DRILL Co., 115 Broadway, New York, N. Y., Pile Hammers, 16 pages.

ROBERTS & SCHAEFER Co., Chicago, Ill., Bulletin No. 22, Modern Coal Mining Plants, 55 pages.

WHEELER CONDENSER AND ENGINEERING Co., Carteret, N. J., Bulletin No. 103, Wheeler-Edwards Air Pump, 32 pages.

來 來

Obituary

JOHN BOND ATKINSON

John Bond Atkinson, President of the Kentucky Mining Institute, and a pioneer coal operator of Western Kentucky, died at his summer home, near Wrightstown, N. J., on September 21. Mr. Atkinson went to Kentucky when a young man and took pride in advancing the interests of the state. He was successful in business affairs and gave freely to the cause of education. He served as an official of the state, contributed to the betterment of agricultural conditions, to the cause of forestry, and to the conservation of lands. During his long career as the foremost coal operator in that state he was an engineer of notable ability, eminent in the field of mining not only in his own state but elsewhere.

He was always kind and generous and grew more so with age. The builder of his own fortune he found great satisfaction in the knowledge that he assisted others to also build; he will be missed by a large number of Kentucky citizens.

Centrifugal Mine Ventilators

The Construction of the Guibal Fan Compared with That of a Centrifugal Ventilator of the Newest Design

The fan, while not as expensive as some other machinery, is the most important about the coal mine. Upon it depends the lives of the underground workers to such an extent that with each year's development of a mine the state mine inspectors use greater care in seeing that the laws governing ventilation are enforced. Mine fans should be purchased with a view to serving the mine during its life, and as the extent of a mine can be calculated as a usual thing, the factors that make up the strength and efficiency of a fan are matters of considerable moment. While apparently a crude apparatus, the numerous elements which enter into the construction of a fan, coupled with the changing conditions inside the mines with which it must contend, present problems which antagonize theory to such an extent that only practical experiments will furnish an exact basis for a fan's construction. During the past few years, mine fans have received more attention from mine managers than in any previous time, with the result that the Guibal fan, which was once considered the acme of ventilators, is about obsolete, so far as manufacturers are concerned.

In order to lead up to the improvements that have been made in scientific fan construction, the best fan of 25 years ago is here compared with a new fan made by the J. C. Stine Co. It is to be understood that the centrifugal mine ventilator

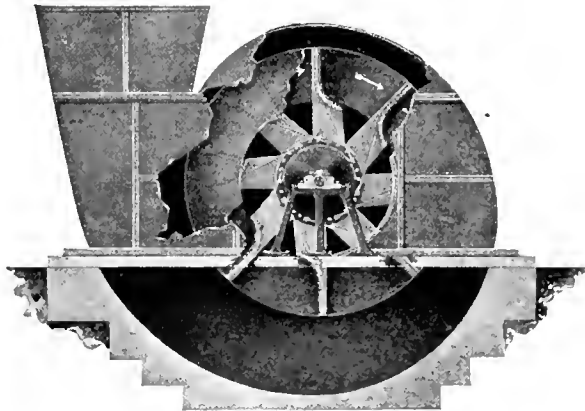

FIG. 1. SHOWING CURVE OF FAN BLADES

depends upon its power to create vacuum, and to fully discharge the compressed air between its blades in such a manner that back pressure will not interfere with the intake air. There is a general similarity in the principles that govern the workings of the centrifugal fan and centrifugal pump; both depend on the pressure of the atmosphere to fill the void created by the swiftly moving blades; also both depend upon the movement of the blades to create a pressure above that of the atmosphere and so permit a discharge from the machine. The tendency of the machines is to whirl the fluids between their blades and cast them off at a tangent to the circle described in their movements, with a force that will produce pressure. At this point the similarity of the two machines might be said to cease, were it not that, to prevent back pressure due to friction of the discharged fluids, both are equipped with spiral casings that gradually reduce the speed, and so the friction, without reducing the pressure.

The atmosphere being a compressible fluid offers a much more complicated problem in a centrifugal fan than the incompressible fluid with which the centrifugal pump deals. Owing to the expansion of air the centrifugal fan cannot discharge the entire quantity compressed between its swiftly moving blades in an instant, consequently the Guibal fan carried part of the air cut out beyond the point of discharge; and since there was no

chance for the air to discharge until it reached the throat of the casing there was friction between the swiftly moving air and the casing which further interfered with efficiency. The modern fan overcomes the first defect by using a spiral casing which

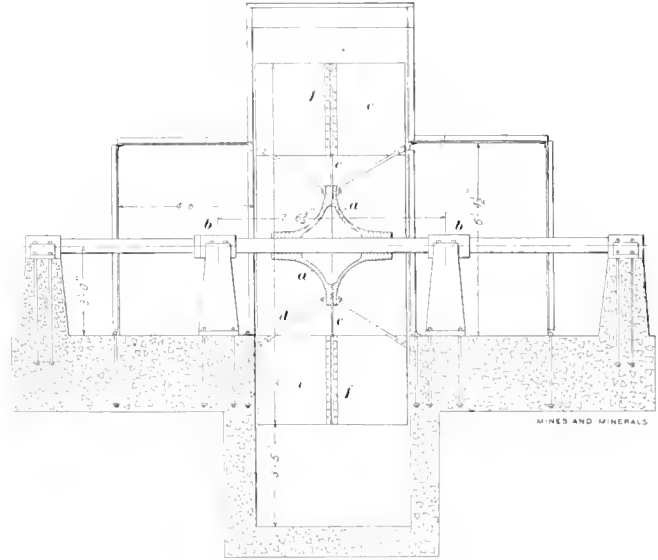

FIG. 2. SECTION THROUGH FAN

permits it to discharge the compressed air in a continuous stream, in fact the volume of air discharged in one revolution is more than two times that discharged by the Guibal fan of the same diameter running at the same speed. To overcome the second defect the fan blades are encased; this prevents friction between the air and the fan casing as well as eddies and baffling. The Guibal fan blades are fastened to spiders keyed to the fan shaft near the intake in the casing. This arrangement necessarily baffles and prevents a free flow of air to the fan. To overcome this defect the blades of the modern fan here considered are centrally fastened to cast-iron cones by heavy steel plates, an arrangement which permits a free and continuous flow of air to the fan. The heavy cast-iron cones, shown at *a*, Fig. 2, are carefully fitted to the shaft and are spread from the center toward the journal boxes *b* for the purpose of reducing torsional or bending strains to a minimum and to gradually turn the stream of air entering through openings on each side of the casing toward the blades. The cast-iron

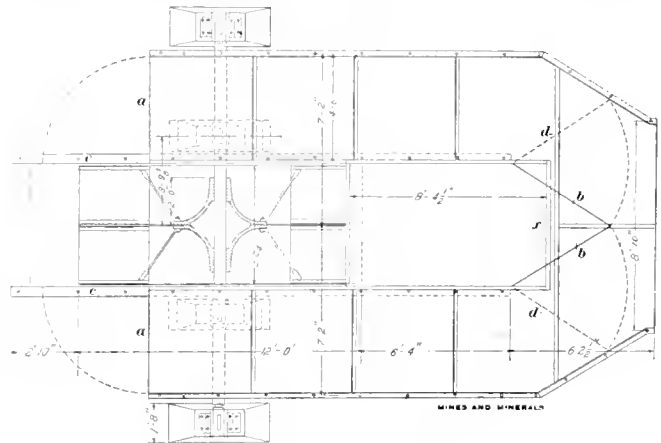

FIG. 3. REVERSING ARRANGEMENT

cones are fitted to the shaft so as to form a hub with the steel plates *c* as spokes. Where the plates are inserted in the hub all parts are machined and the plates shaped so that when bolted to the hub they interlock and fill the entire circle of the hub. To make the parts rigid and to secure them in alinement,

three bolts are passed through each plate and hub. Sway rods *d* are bolted to the hub and also to the fan blades *e*. It was customary to give the fan blades of the Guibal fan a slight backward rake for the purpose of allowing the air to discharge more readily than would be the case should the blades come to the throat at right angles. In the fan here described the blades are curved forward from the inlet opening as shown in Fig. 1 to allow the air to slide forward and discharge radially at the circumference. Experiments show that more air will be discharged with less power expended when this form of blade is used.

The blades are riveted to the angle irons *f*, which are also riveted to the arm plates *c*, an arrangement which adds to the stiffness of the arms. The sides of the blades are riveted to angle bars that in turn are riveted to the fan casing which, as stated, forms part of the fan. The Guibal fan was used almost entirely as an exhaust fan; this fan can be used either as an exhaust fan or a blower by opening or shutting the doors shown in Fig. 3. When it is desired to use the fan as an exhaust the door in the chimney is lowered by a pulley and rope to cover the opening *x*; when, however, the fan is to work as a blower the door is raised to prevent the air passing out of the chimney. The plan shows the arrangements of doors in the air passages for converting the fan from an exhaust to a blower. When used as an exhaust fan the doors are in the positions *a* and *b*; when used as a blower the door to the chimney is closed and the doors swing to the positions *c* and *d* to close the air passages. This forces the air coming through the doors *a c* into the fan and so through the opening *x* into the mine.

Book Review

THE PRACTICE OF COPPER SMELTING, by Prof. Edward D. Peters, of Harvard University, is the latest on copper. The book has 619 pages of reading matter, including 121 illustrations. The publishers are McGraw-Hill Book Co., New York and London. Price \$5. Doctor Peters' intention of replacing his "Modern Copper Smelting" with this book is praiseworthy so far as the younger generation is concerned, but he will hardly accomplish his ambition with the older generation, for the dissemination of knowledge like the conservation of energy or Tennyson's brook, "goes on forever." Were this otherwise he could not have compiled this present book. The "Practice of Copper Smelting" consists of the author's studies and those of others engaged in practical operations, and he makes use of the investigations, comparisons, discussions, and results obtained to arrive at the fundamental principles of the subjects treated. These are: Ores of Copper; Sampling Copper Ores; Methods of Copper Extraction; Behavior of Ores at High Temperatures; Roasting; Blast Furnace; Blast-Furnace Smelting; True Pyrite Smelting; Partial Pyrite Smelting; Reverberatory Furnaces; Reverberatory Smelting With Wood; Blast Furnace vs. Reverberatory; Fines; Production of Metallic Copper From Matte; Refining of Copper; Flue Dust and Smoke; Slags; Miscellaneous, including furnace construction. Doctor Peters, in his introduction, writes: "Among many sources of information it is proper to designate particularly the Anaconda Copper Mining Co., whose attitude toward the scientific investigator constitutes a personal favor to every student of metallurgy." With the assistance of the personnel of this most progressive copper company and others to whom he refers, he has been able to produce a book which will remain a classic for some years. When coupled with his "Principles of Copper Smelting," the metallurgist's library is complete, so far as dry copper treatment is advanced to date.

ROCK MINERALS, by Joseph P. Iddings. Price \$5. John Wiley & Sons, New York, publishers. This second edition has been revised and enlarged by the addition of 80 minerals.

The study of rocks and their mineral components involves so many kinds of investigations, chemical, physical, mineralog-

ical, and geological, that no petrologist is likely to follow all of them to their ultimate limit, but must content himself with some special branch of the subject, leaving to others the work in other branches." "The student beginning the subject of petrology needs at least an introductory knowledge of the branches of science that underlie mineralogy in order to apply certain of the principles to the study of rocks." This book is not intended to do away with mineralogy, but to determine rock minerals by physical tests and optical properties when in thin sections. Part I covers the general principles involved and the methods to be followed in research. Part II is descriptive mineralogy and involves a long list of minerals.

MINING LAW FOR THE PROSPECTOR, MINER, AND ENGINEER. H. W. MacFarren, author, offers a very satisfactory apology when he states that "the present standard books on the subject are the production of mining attorneys, and are more valuable for practicing attorneys than for miners." In addition to the hardships and natural difficulties involved in prospecting, several more have been recently tacked on, chief of which is the chance of developing another's "near claim," particularly if a good vein is discovered. The value of Mr. MacFarren's book will be appreciated by engineers, miners, and prospectors who realize the number of "buzzards" hovering over and ready to pounce on the man who makes a find and take it from him. To these men—not the "buzzards"—the book will appeal and find a ready sale. The price is \$2 postpaid. Published by the Mining and Scientific Press, San Francisco, Cal.

THE MINERAL INDUSTRY, Vol. XIX, edited by Albert H. Fay. Published by McGraw-Hill Book Co. Articles for this volume have been prepared by 76 different authors. The table of contents shows 56 different subjects of commercial importance to the mining and metallurgical industry, besides special chapters on Sulphur Smoke of Metallurgical Works; Dredging; Mining Practice; Ore Dressing and Coal Washing; Assaying and Sampling; Mineral Statistics. The "Mineral Industry" is well known to all miners and metallurgists. As a reference book it is a necessity. Each year new subjects like Fixation of Atmospheric Nitrogen, difficult to obtain, and then piecemeal, are added. How much better Vol. XIX is than Vols. XVIII, XVII, XVI, and XV only those can tell who have them.

BOOKS RECEIVED

UNITED STATES GEOLOGICAL SURVEY PUBLICATIONS, Washington, D. C., Bulletin No. 470-C, Advance Chapter from Contributions to Economic Geology, 1910, Copper, by Sidney Paige, W. H. Emmons, and F. B. Laney; Bulletin No. 474, Coals of the State of Washington, by Eggleston Smith; Bulletin No. 481, Results of Spirit Leveling in California, 1907 to 1910, inclusive, by R. B. Marshall, Chief Geographer; Bulletin No. 482, Results of Spirit Leveling in Montana, 1896 to 1910, inclusive, by R. B. Marshall, Chief Geographer; Bulletin No. 487, Results of Spirit Leveling in Idaho, 1896 to 1909, inclusive, by R. B. Marshall, Chief Geographer; The Production of Quicksilver in 1910, by H. D. McCaskey; The Production of Mineral Waters in 1910, by George Charlton Matson; The Production of Barytes and Strontium in 1910, by Ernest F. Burchard; The Production of Fluorspar and Cryolite in 1910, by Ernest F. Burchard; The Production of Sulphur and Pyrite in 1910, by W. C. Phalen; The Production of Abrasive Materials in 1910, by W. C. Phalen; The Gypsum Industry in 1910, by Ernest F. Burchard; The Production of Chromic Iron Ore in 1910, by Ernest F. Burchard. Water-Supply Paper No. 266, Surface Water Supply of the United States, 1909, Part VI, Missouri River Basin, by W. A. Lamb, W. B. Freeman, and F. F. Henshaw; Water-Supply Paper No. 275, Geology and Water Resources of Estancia Valley, N. Mex., by Oscar E. Meinzer; Water-Supply Paper No. 277, Ground Water in Juab, Millard, and Iron counties, Utah, by Oscar E. Meinzer. Professional Paper No. 75, Geology and Ore Deposits of the Breckenridge District, Colo., by Frederick Leslie Ransome.

Answers to Examination Questions

Questions from Illinois Examinations, 1910, for Mine Managers, Mine Examiners, and Hoisting Engineers

(Continued from October)

QUES. 5.—A door, 5 ft. × 6 ft., is placed on a main entry 800 feet from the bottom of downcast shaft, and between two cross-entries driven east 1,200 feet. All entries are 6 ft. × 8 ft. in section; the velocity of the air-current is 500 feet per minute, barometer 30 inches, temperature 60° F. What is the pressure per square foot and the total pressure acting to keep the door closed?

M., Q. 7, 1-17-10

ANS.—The pressure acting to keep the door closed is the difference of pressure between the two sides of the door, which is due to the resistance offered by the cross-entries to the passage of the air-current through them. This difference of pressure at the door is

$$p = \frac{k l o v^2}{a} = \frac{.00000002 \times 2,400 \times 28 \times 500^2}{48} = 7 \text{ lb. per sq. ft.}$$

The total pressure acting on the door to keep it closed is then 5 × 6 × 7 = 210 pounds. The distance of door from downcast shaft, and density of the air, as determined by the barometer and temperature are not considered here, as they do not affect the question practically.

QUES. 6.—Give the dimensions of a mine car built to hold 3,000 pounds of coal when the height of the coal in the seam is 4 feet 6 inches; there is a good roof and 2 feet of fireclay underlies the coal. Give sizes of wheels and axles.

M., Q. 8, 1-17-10

ANS.—A ton of mine-run bituminous coal will occupy 40 cubic feet of space, and 3,000 pounds of this coal will require $\frac{3,000}{2,000} \times 40 = 60$ cubic feet, which must be the cubic capacity of the car. Then, adopting the style of mine car shown in Fig. 2, and taking the track gauge as $g = 42$ inches, the inside width of the car at the bottom is $g - 6 = 42 - 6 = 36$ inches, and at top $g + 8 = 42 + 8 = 50$ inches. Using 18-inch wheels the depth of the lowest section of the car is $\frac{d}{2} = \frac{18}{2} = 9$ inches. The area of this section, in Fig. 2, is therefore $36 \times 9 = 324$ square inches. The depth of the middle section (Fig. 2) is 7 inches, and its area $7 \times \frac{1}{2}(36 \times 50) = 301$ square inches. If the coal is undercut at the face so as to take out 10 inches of the under-clay the total headroom from floor to roof would be 4 ft. 6 in. + 10 in. = 64 inches. Then, allowing 6 inches for ties and rails, 9 inches for half-diameter of car wheels, 3 inches for half thickness of axle and car bottom; the two lower sections of the car being $9 + 7 = 16$ inches deep, if the top section is made 16 inches, this will leave $64 - (16 + 9 + 3 + 16 + 16) = 14$ inches for topping of coal and roof clearance. Call the coal topping 6 inches and the roof clearance 8 inches. The depth of coal in the top section, including the topping is then (Fig. 2) $x = 16 + 6 = 22$ inches, and the area of coal in this section is $50 \times 22 = 1,100$ square inches. This gives for the total sectional area of coal in the car $324 + 301 + 1,100 = 1,725$ square inches, or $1,725 \div 144 = \text{say, } 12$ square feet. The clear, inside length of the car must then be $60 \div 12 = 5$ feet. Use $2\frac{1}{2}$ -inch, square, Swedish-iron axles.

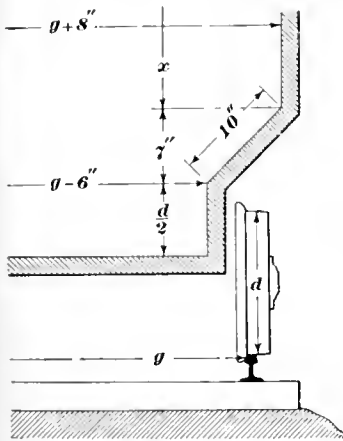

FIG. 2

for topping of coal and roof clearance. Call the coal topping 6 inches and the roof clearance 8 inches. The depth of coal in the top section, including the topping is then (Fig. 2) $x = 16 + 6 = 22$ inches, and the area of coal in this section is $50 \times 22 = 1,100$ square inches. This gives for the total sectional area of coal in the car $324 + 301 + 1,100 = 1,725$ square inches, or $1,725 \div 144 = \text{say, } 12$ square feet. The clear, inside length of the car must then be $60 \div 12 = 5$ feet. Use $2\frac{1}{2}$ -inch, square, Swedish-iron axles.

QUES. 7.—What load will break a 10" × 10" white-oak beam, 12 feet between supports, uniformly loaded its entire length?

M., Q. 10, 1-17-10

ANS.—For a uniform load W , Bending moment = $\frac{Wl}{8}$

when the beam is supported at both ends (Fig. 3). The bending moment of any beam is equal to the moment of inertia of the beam, divided by the distance of the extreme fiber from its neutral axis; or,

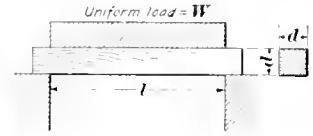

FIG. 3

in this case (square beam, side = d) $\frac{d^4}{12} \div \frac{d}{2} = \frac{d^4}{12} \times \frac{2}{d} = \frac{d^3}{6}$; and multiplied by the fiber stress (f). Hence,

$$\frac{Wl}{8} = \frac{f d^3}{6}; \text{ or } W = \frac{4 f d^3}{3 l}$$

All the dimensions of the beam are expressed in inches; thus, $d = 10$ inches; $l = 12 \times 12 = 144$ inches. The breaking strength (ultimate fiber stress) of white oak may be taken as 10,000 pounds per square inch; or $f = 10,000$. Then,

$$W = \frac{4}{3} \left(\frac{10,000 \times 10^3}{144} \right) = 92,592 + \text{lb.}; \text{ or say, } 46\frac{1}{2} \text{ tons}$$

QUES. 8.—A pair of hoisting engines have cylinders 30 inches in diameter; the stroke is 60 inches; the steam pressure 90 pounds per square inch. How many revolutions per minute will they be running when generating 1,000 horsepower?

M., Q. 14, 1-17-10

ANS.—With only the data given it would not be possible to answer the question asked, as it is necessary to know the mean-effective steam pressure in the cylinders. Assuming, however, the steam pressure is 90 pounds at the throttle and the engines cut off at, say $\frac{1}{2}$ stroke, then

$$M. E. P. = .9 [90(90 + 14.7) - 17] = \text{say, } 70 \text{ lb. per sq. in.}$$

The total mean pressure exerted in one cylinder is then $.7854 \times 30^2 \times 70 = 49,480$ pounds. In order that this cylinder shall develop 500 horsepower (1,000 horsepower, two cylinders),

$$\text{the piston speed must be } \frac{500 \times 33,000}{49,480} = 333.4 \text{ feet per minute;}$$

or, since the stroke is $60 \div 12 = 5$ feet, the engines must run at $333.4 \div 2 \times 5 = \text{say, } 33\frac{1}{2}$ revolutions per minute.

QUES. 9.—The temperature of the air in the downcast shaft of a certain mine is 60° F., and that in the upcast 100° F. The quantity of air entering the mine as measured in the downcast is 20,000 cubic feet per minute. Each shaft is 15 feet in diameter. What is the velocity of the air-current in each shaft, respectively?

M., Q. 16, 1-17-10

ANS.—The sectional area of each shaft is $.7854 \times 15^2 = 176.7$ square feet. The velocity of the air-current in the downcast is then $20,000 \div 176.7 = 113.18$ feet per minute. Assuming that the pressure on the air is practically the same in each shaft, the difference being very small, the air volume, and for the same area, the velocity of the current, each varies with the absolute temperature. In other words, the velocity ratio is equal to the absolute-temperature ratio. Thus, calling the required velocity in the upcast x ,

$$\frac{x}{113.18} = \frac{460 + 100}{460 + 60} = \frac{560}{520} = \frac{14}{13}$$

and $x = 113.18 \times \frac{14}{13} = 121.88 \text{ ft. per min.}$

QUES. 10.—How far can a pair of entries be driven without a cap showing on a safety lamp, if the air-current at the upcast is 4,000 cubic feet per minute, and assuming that the coal gives off 1 cubic foot of marsh gas in every 90 feet of each entry? Give the proportion of gas and air in the mixture.

M., Q. 17, 1-17-10

ANS.—With the unbonneted Davy, burning ordinary sperm or cottonseed oil, it is possible to detect the first cap when there is 2.5 per cent. of marsh gas in the air-current, which, in

this case, would result from $4,000 \times .025 = 100$ cubic feet of gas. At the rate of 1 cubic foot of gas given off by each 90 feet of entry it would require $100 \div 90 = 9,000$ feet of entry to produce this quantity of gas; or one-half this length of double entry, or 4,500 feet. The proportion of gas to air in this mixture is 2.5 volumes of gas to 97.5 volumes of air, making 100 volumes of mixed air and gas; or 1 of gas to $\frac{97.5}{2.5} = 39$ volumes of air; expressed as 1:39.

QUES. 11.—How long will it take an air-current of 20,000 cubic feet per minute to make the circuit of a $10' \times 10'$ airway 12,000 feet long? M., Q. 18, 1-17-10

Ans.—The velocity of the air-current, in this airway, is $\frac{20,000}{10 \times 10} = 200$ feet per minute. The time required for air traveling at this rate to pass through an entry 12,000 feet long is $12,000 \div 200 = 60$ minutes, or 1 hour.

QUES. 12.—The quantity of air passing in a certain mine ventilated by a furnace is 150,000 cubic feet per minute when the furnace consumes 5 tons of coal in 12 hours. What increased circulation will be obtained by burning 5 additional tons of coal in the furnace in 12 hours (doubling the fuel consumption)? M., Q. 19, 1-17-10

Ans.—In furnace ventilation the power developed is proportional to the weight of coal burned per hour. When the coal burned per hour is doubled the fuel ratio and likewise the power ratio are each 2. Since, for the same mine or airway, the quantity of air in circulation varies as the cube root of the power, the quantity ratio is equal to the cube root of the power ratio; or, in this case, $\sqrt[3]{2} = 1.26$. The increased circulation would then be $1.26 \times 150,000 = 189,000$ cubic feet per minute.

QUES. 13.—What horsepower would an engine develop when yielding 60 per cent. efficiency and furnishing the power to circulate 100,000 cubic feet of air in a mine, against a water gauge of 1 inch? M., Q. 20, 1-17-10

Ans.—The indicated horsepower of the engine in this case is

$$I. H. P. = \frac{100,000 \times 1 \times 5.2}{.60 \times 33,000} = 26.26 \text{ H. P.}$$

QUES. 14.—How would you measure the quantity of air passing in an airway without an anemometer? E., Q. 5, 1-17-10

Ans.—A simple method often employed is to touch off a small quantity of powder at a certain point in the airway, and observe carefully the exact time between the flash of the powder and the first appearance of smoke at a point say 100 yards from the powder. The distance, in feet, divided by the time observed, in minutes, will give the observed velocity of air-current in the center of the airway. The average velocity may then be taken as about .8 of this observed velocity, because the air travels faster in the center than at the sides of the airway.

QUES. 15.—What is a regulator and when can it be used to advantage in the mine? E., Q. 6, 1-17-10

Ans.—A regulator, in mine ventilation, is any device for dividing the air-current proportionately between the several districts of a mine. The most common form is the box regulator, which consists of a door or brattice erected in airway or cross-cut, and provided with a small opening, the size of which can be increased or decreased at will by means of a sliding shutter. Any desired proportion of the air is thus allowed to pass through the regulator for the ventilation of a separate district or portion of the mine. It is used whenever more air is required in certain parts of the mine than is supplied by the natural division of the air-current.

QUES. 16.—What is blackdamp, how is it produced, and where found in mines? E., Q. 7, 1-17-10

Ans.—Blackdamp is any mixture of extinctive gases as they occur in mines. The mixture consists chiefly of carbon dioxide and nitrogen, and is the result of the complete combustion of carbon in air, by which the oxygen of the air com-

biner with the carbon to form carbon dioxide, leaving an excess of nitrogen. It is found mostly in low parts of the mine and in abandoned places where ventilation is slack and these gases accumulate.

QUES. 17.—The hand of an anemometer makes 3.25 turns in 1 minute; the airway is 6.25 ft. \times 8.5 ft. What is the velocity of the air-current, allowing 3 per cent. loss for resistance of the anemometer? E., Q. 11, 1-17-10

Ans.—The size of the airway is not concerned in finding the velocity of the air-current. One turn of the hand, in the type of instrument here meant, corresponds to 100 revolutions of the vane, or 100 feet of air travel, as indicated by the dial; and 3.25 turns in 1 minute indicates a velocity of the air-current of 325 feet per minute. But allowing for a loss of 3 per cent. due to friction, this velocity is $100 - 3 = 97$ per cent. of the true velocity. The actual velocity is therefore $325 \div .97 = 335+$ feet per minute.

QUES. 18.—If 5 cubic feet of gas was to explode, how many cubic feet of flame would result? E., Q. 14, 1-17-10

Ans.—The question does not specify the kind of gas or whether the same is mixed with air so as to form an explosive mixture, and in what proportion, or whether 5 cubic feet of pure (undiluted) gas is meant. If 5 cubic feet of firedamp (CH_4 and air) at its most explosive point (1 vol. gas : 9.57 vol. air) is exploded in free air (unconfined), the theoretical flame temperature is $4,173^\circ$ F., giving $\frac{460 + 4,173}{460} = \text{say, } 10$ expansions

of the gases produced by the explosion; or since the volume of these gases, at the same temperature and pressure is equal to the volume of firedamp exploded, there is produced 10 volumes of flame; or, in this case, $10 \times 5 = 50$ cubic feet. In the case of carbon monoxide mixed with air, at the most explosive point (1 vol. CO : 2.39 vol. air) although theoretical flame temperature ($5,287^\circ$ F.) is much higher, giving $\frac{460 + 5,287}{460} = 12.5$ expansions, yet owing to the change in volume that occurs in this reaction the flame volume is reduced 15 per cent. and is $12.5 \times .85 = 10\frac{2}{3}$ volumes; or for 5 cubic feet of the original mixture of gas and air $5 \times 10\frac{2}{3} = 53\frac{1}{3}$ cubic feet of flame. If the question, however, means 5 cubic feet of gas (undiluted with air), since this gas is 9.46 per cent. of the above firedamp mixture the resulting flame volume would be $50 \div .0946 = \text{say, } 530$ cubic feet.

QUES. 19.—A current of 9,000 cubic feet of air per minute is passing through a regulator having an opening 20 in. \times 30 in. How much air will pass through the regulator if the opening is made 30 in. \times 30 in., the pressure and rubbing surface being the same in each case? E., Q. 15, 1-17-10

Ans.—If the pressure due to the regulator is the same in each case, the quantity of air passing through the opening will increase with the size of the opening; or, in this case, in the ratio 30 : 20, or $\frac{3}{2}$, and the volume of air will then be $\frac{3}{2}$ (9,000) = 13,500 cubic feet per minute. This would, however, require that the ventilating pressure on the airway be increased in the ratio $\left(\frac{3}{2}\right)^2 = \frac{9}{4}$, or 2 $\frac{1}{4}$ times. It is more probable that the question means the ventilating pressure remains unchanged when the opening in the regulator is enlarged. In that case, it is necessary to know both the area and rubbing surface of the airway. Assuming, $a = 50$ square feet, and $s = 100,000$ square feet, the increased quantity passing through the regulator when the area of the opening is enlarged from $\frac{20 \times 30}{144} = 4.167$ square feet, to

$$\frac{30 \times 30}{144} = 6.25 \text{ square feet is}$$

$$q_2 = 9,000 \times \frac{6.25}{4.167} \sqrt{\frac{50^3 + .026 \times 100,000 \times 4.167^2}{50^3 + .026 \times 100,000 \times 6.25^2}} = \text{say, } 11,700 \text{ cu. ft. per min.}$$

ORE MINING AND METALLURGY

Treatment of Broken Hill Ores

Methods of Grinding—Concentrating by the Magnetic, the Flotation and the Oil Processes

By W. Poole, B. E.*

This paper, which was read before the Sydney University Engineering Society, is divided into three parts. Part I is the one printed in this issue and is on concentration of ores.

The immense lode of ore at Broken Hill is mined by 10 large and several small companies. The upper or oxidized portion of the lode was marvellously rich in silver and lead, besides ores and minerals of lesser value. The variety of minerals found in the Broken Hill lode is, perhaps, unequaled at any other spot in the world.

The unaltered ore consists of a mixture of galena, blende, quartz, rhodonite, garnet, and small quantities of calcite, pyrite,

and in places containing small patches of copper. Above this zone, where the lode outcropped, was the capping of iron manganese gossan, containing in places rich silver chloride. Of the more important constituents it will be noticed that the zinc was the first to be oxidized and eliminated; later on, the copper; then lead; and last, the capping remains, composed of oxidized iron and manganese, and containing silver as chloride. The oxidized ores were smelted in blast furnaces, the iron-manganese gossan being used as flux with limestone brought from elsewhere.

A 50-head stamp battery and amalgamating plant was erected by the Broken Hill Proprietary Co. for treating dry silver ores, but was not a success. A hyposulphite lixiviation plant, built by the same company for treating dry ores, was much more successful, and ran until the remaining dry ores were required for duxing purposes at the Port Pirie smelters. The friable sulphide, after considerable preliminary trouble, was directly treated at the metallurgical works, but the crude

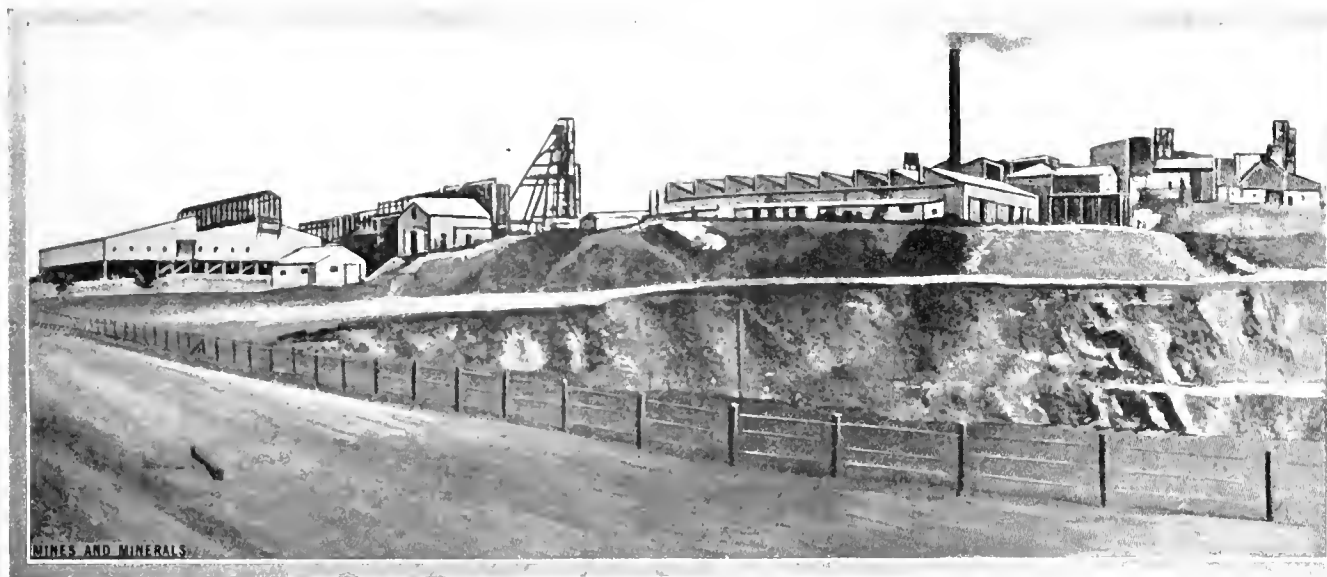

FIG. 1. SOUTH MINE, BROKEN HILL, AUSTRALIA

etc., in varying but omnipresent quantities. The ore generally contains lead and zinc in roughly equal amounts, with about as many ounces per ton of silver as there is per cent. of either lead or zinc. The average metal contents are gradually decreasing at greater depths. The galena is almost pure, except for the ever-present silver. The blende, on the other hand, is impure, with appreciable quantities of sulphides of iron and manganese.

Above the unaltered sulphides was a zone of friable sulphide ore high in lead and silver, but low in zinc. The zinc sulphide had been oxidized to sulphate, etc., and leached, leaving the ore open and friable. The stopes in this zone were perceptibly hotter and the air fouler than those in the hard sulphides—no doubt due to the chemical action of oxidation still in progress.

Above the friable sulphides was the carbonate zone, containing oxidized lead ores with high silver contents, kaolin, and highly siliceous ores, at times exceeding high in silver,

unaltered sulphides could not be economically smelted for either lead or zinc. Large ore-dressing plants have been built, and complicated processes have been evolved for separating the ore into four products, viz.:

1. Lead concentrate containing small quantities of zinc and gangue.
2. Zinc concentrate containing small quantities of lead and gangue. Both concentrates are shipped to various places to be smelted for their main constituent and silver.
3. The zincky (so-called) tailing, of which there are upwards of 1,000,000 tons stacked. This is really an intermediate product running high in zinc and now being treated by the various flotation processes for its large zinc and silver and small lead contents.
4. Worthless tailing from one of the flotation or magnetic processes, being the product of (3), or the continuous treatment of the crude ore.

The general practice of ore breaking is as follows: The ore from the mine is tipped on to grizzlies, the undersize going to

* Director of Charters Towers School of Mines.

the lower bin and the oversize into the breaker supply bin, from which it is fed to gyrating breakers, the broken product rejoining the undersize that passes through the grizzly.

The almost universal practice is to recrush this product with slow-speed geared Cornish rolls 30 inches to 36 inches in diameter, and making about 15 to 20 revolutions per minute. The oversize, after the product has been screened, is returned to the same rolls. The exception to the general practice is the use of high-speed Gates rolls in the Broken Hill Proprietary Co.'s new mill. This mill has a nominal capacity of 6,000 tons per

per minute. The product is screened, and the oversize conveyed to an elevator and elevated to bins, which supply rolls Nos. 7 and 8, which are set at $\frac{1}{8}$ -inch apart and running at 78 revolutions per minute. The oversize, after screening, is elevated to a bin, which supplies a No. 5 Krupp ball mill, from which no ore can escape before it is crushed to a sufficient fineness to pass the screens.*

It is interesting to note that the speed at which these rolls are driven has been reduced from time to time in order to obtain better efficiency. The rolls on $1\frac{1}{2}$ -inch to 2-inch ore were originally run at about 45 revolutions per minute, and the others, on finer ore, at about 90 revolutions per minute. Four new mills have been built, and the old ones remodeled, since these high-speed rolls were installed, but in no case have similar rolls been installed. It is always the slow-speed geared type. It has been found that both classes of rolls do better work when crushing wet ore than dry ore. In the former case, the fine particles cling to the rolls, thus sanding the track and giving the rolls a more effective nip.

The ore is crushed to pass through 2-millimeter holes in punched-plate screens. Formerly a pair of cylindrical trommels, about 2 feet diameter by about 6 feet long, screened the product of each set of rolls. These small trommels were covered with either woven-wire cloth or punched plate. The Broken Hill Proprietary Co. introduced large conical trommels. Nearly all revolving trommels have now been replaced by shaking screens, which admit of more ready inspection and repairs, besides require less wash water. A very effective modification of the shaking screen is in use at the British Broken Hill Co.'s mill, and consists of a punched plate with corrugations of about 2-inch radius at right angles to the direction of inclination and shake. The effect of the corrugations, in conjunction with the end shake, is to bring all particles in repeated contact with the screen, and so give the undersizes full opportunity to pass through. The oversize discharged is very free from fines.

In general, the oversize is returned for crushing to the same rolls, except in the Broken Hill Proprietary Co.'s new mill. The oversize is elevated to the rolls either by raff wheels or belt elevators, both means of elevation being largely used.

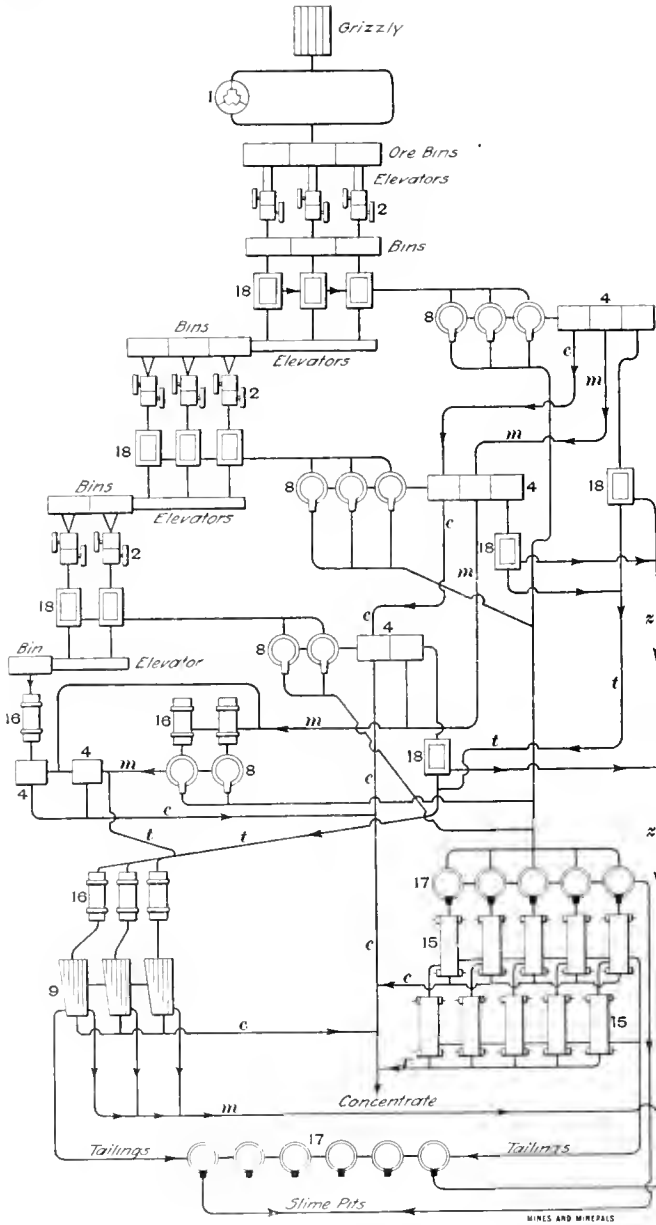

FIG. 2. BROKEN HILL PROPRIETARY COMPANY'S TREATMENT
 1 crusher; 2 rolls; 4 jigs; 8 classifiers; 9 concentrating tables; 15 Frue vanners; 16 tube mill; 17 spitzkasten; 18 shaking screen; c concentrate; m middling; t tailing

6-days of 24 hours. Here progressive comminution has been more fully applied than elsewhere at Broken Hill. There are nine sets of these rolls, each 36 inches in diameter by 15 inches wide. Ore broken to 1-inch to 2-inch gauge is, after screening, fed with a stream of water to three sets of rolls set $\frac{3}{8}$ -inch to $\frac{1}{2}$ -inch apart and making 30 revolutions per minute. After crushing and screening, the oversize from the shaking screen is conveyed on an endless horizontal belt to a bucket elevator, where it is elevated to bins which supply a second batch of three sets of rolls. These rolls are set $\frac{1}{8}$ -inch to $\frac{1}{16}$ -inch apart, and run at 45 revolutions

TABLE 1. ANALYSES OF CRUDE ORE AND OVERSIZE FROM TROMMELS

Sieve*	Crude Ore Per Cent.	Raffs Per Cent.
Caught on 8.....	55.8	54.3
Caught on 20.....	14.8	33.9
Caught on 40.....	9.0	7.3
Caught on 60.....	5.0	1.0
Caught on 80.....	3.8	.7
Caught on 100.....	3.0	through 80 .8
Caught on 120.....	2.3	
Caught on 150.....	1.9	
Through 150.....	4.1	

	Crude Ore Per Cent.	Raffs Per Cent.
Insoluble.....	41.0	50.0
FeO.....	5.8	4.7
CaO.....	2.8	6.3
Pb.....	18.9	14.5
Zn.....	14.6	13.3
Ag ounces per ton.....	13.0	11.0

* All sieves are quoted at openings per linear inch.

The sizing analyses show that the coarse ore from the breakers contains a larger percentage of fine ore than the oversize from the trommels, and also that the former contains a larger percentage of metals and less siliceous matter than the latter.

The undersize from the screens is passed to hydraulic classifiers, the overflow going to spitzkasten and the underflow to

*G. D. Delprat, on "Ore Treatment at Broken Mill." Trans. Aust. Institute of M. E., Vol. XII.

the jigs. These classifiers do not make a clean separation of fine ore and slime, and a considerable portion of the latter passes to the jigs, as will be seen from the sieve analyses.

The Hancock jigs and May jigs are used. The Hancock jig is of movable sieve type, about 20 feet long and 2 feet 6 inches wide, with four sieve product hutches and a tailing hutch. These jigs do good work, but unless they are carefully operated splashings containing grit get into the working parts, which are mostly underneath.

The May jig is of the fixed sieve type, and is built double, i. e., has a set of plunger and sieve compartments on each side of the longitudinal center line. There are four sieve product hutches and one tailing hutch on each side, besides an overflow at the tailing hutch for surplus water and slime. The plungers are worked by rocking arms operated by cranks on a countershaft. There are two rocker-shafts with a pair of rocker-arms to each shaft, a pair of plungers on one side working in unison with each other, and in alternation with the pair on the same shaft on the other side of the jig, and also alternating with the other pair on the same side of the jig, but attached to the other rocker-shaft. The throw of the crank is adjustable, altering the stroke of its set of plungers. The stroke of each plunger may be also independently altered. The capacity of these jigs is great. They do good work, giving great satisfaction and little trouble, and are preferred to the Hancock, despite the great and justifiable reputation this latter jig has achieved in concentrating copper ores both in Australia and America. Both of these jigs were invented and perfected in South Australia. The bed sieve of the jigs is of woven brass wire held between two gridiron frames. The bedding on the sieve is granulated cast iron or disks of small diameter punched from iron plates. The May jigs on coarse feed are driven at a speed of about 180 pulsations per minute. Similar jigs on fine, i. e., reground feed, work at about 270 pulsations per minute.

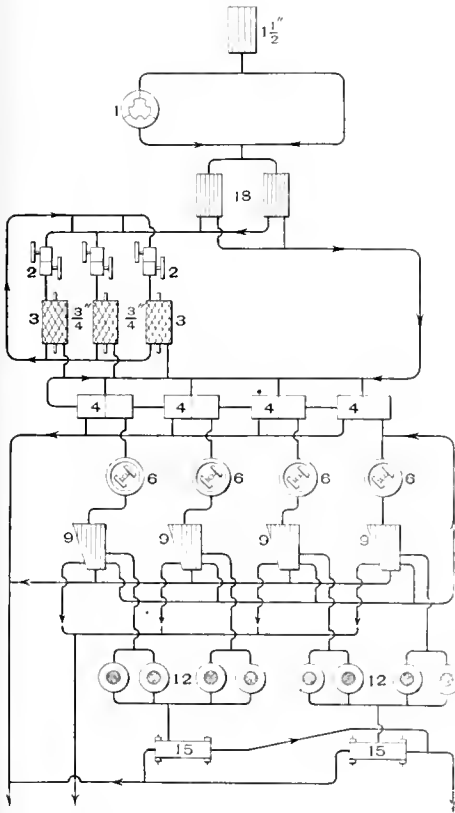

FIG. 3. BROKEN HILL SOUTH MINE PROCESS
1 crusher; 2 rolls; 3 trommel; 4 jigs; 6 grinding pans; 9 concentrating tables; 12 pulp thickeners; 15 Frue vanners; 18 shaking screen

The regrinding of the middling product to free the intimately associated minerals presents an interesting development. At first, narrow high-speed rolls were used; then the Herberli mill was used for this purpose, and was almost exclusively so employed for a number of years. The Herberli mill is a grinder with vertical circular disks set slightly eccentric to each other, one disk revolving at high rate of speed and the other at a slow rate in the same or opposite—usually the latter—direction. The pulp is fed under slight hydraulic head through the hollow shaft on one disk. The pressure on the disks is regulated by a

screw acting against a steel coil spring. The objections to these grinders was that they sometimes gave a poorly ground product and at the same time an undue amount of slime. This undesirable result was in part due to the grinding faces of the disks not being true to each other, i. e., pressing tightly together at one side, producing slime, while the gap on the other side allowed material to pass through with little or no abrasion. This defect was partly remedied by a simple alteration, viz., instead of attaching the disks to their shaft, the end of the solid shaft was squared, and the corresponding disks were cast with a hollow-square collar, so that the disc now fitted on loosely, and, on pressure being applied by the regulation screw it fitted flat against the other disk. The effect of this simple alteration was marked. On the one hand it reduced the percentage of coarse, and on the other reduced that of slime. Wet crushing in Krupp ball mills was tried. The results were so satisfactory that the Herberli mills were rapidly discarded in their favor. The recrushing in the ball mills had the following advantages: The product has to pass through a screen; it is, therefore, under perfect control as to maximum size of issuing pulp grains, and at the same time a lessened percentage of slime is produced, giving a higher percentage of lead and silver recovery.

Grinding pans of the most modern types have since been very widely introduced, with most gratifying results, displacing or throwing out of commission many of the ball mills. Grinding pans instead of ball mills are being installed in the new mills recently completed or being erected. They have a lesser initial cost, are cheaper to operate, give less trouble, and, whilst grinding to a given maximum fineness, produce less slime than ball mills.

The success of the improved grinding pans in reducing the galena-blemle ores of Broken Hill parallels its success in fine grinding auriferous ore in Western Australia and elsewhere, and for tin ores in North Queensland. It has been found by experiment in North Queensland that the ball mill is inferior to the grinding pan for fine grinding tin, wolfram, and tin-wolfram. Recently the Broken Hill Proprietary Co. has been installing tube mills in place of ball mills for regrinding coarse tailings. The result is reported to be very satisfactory.

After the middling product of the coarse jigs has been reground it is elevated to hydraulic classifiers, the underflow passing to fine jigs and the overflow to the pointed boxes prior to treatment on tables and vanners. Three products are made—concentrate, middling, and tailing. The middling is reground, usually in ball mills with a fine sieve, or in grinding pans, and then returned to the hydraulic classifier of the same jig.

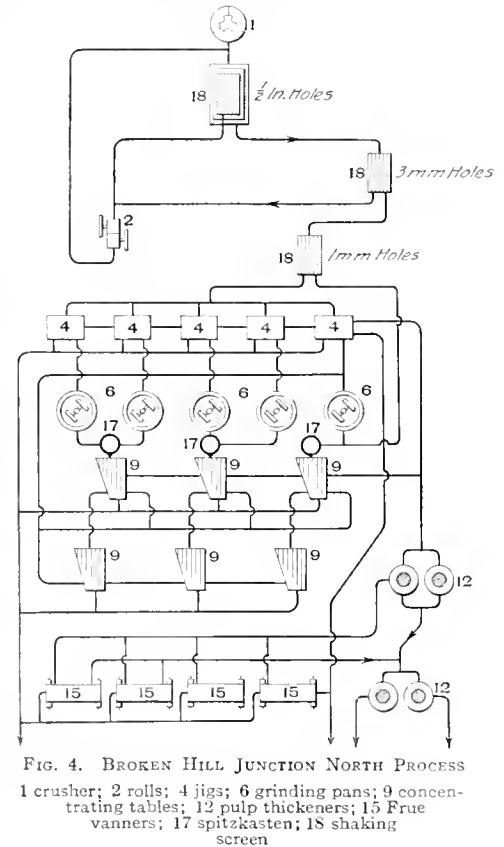

FIG. 4. BROKEN HILL JUNCTION NORTH PROCESS
1 crusher; 2 rolls; 4 jigs; 6 grinding pans; 9 concentrating tables; 12 pulp thickeners; 15 Frue vanners; 17 spitzkasten; 18 shaking screen

Tables 2 and 3 show an analysis of jig products:

TABLE 2

	Coarse Jigs				Fine Jigs	
	Feed	Concentrates	Middlings	Tails	Concentrates	Tails
Insol. per cent.	38.0	12.0	42.0	64.0	31.0	49.0
FeO, per cent.	4.4	2.9	5.7	5.5	5.5	6.8
CaO, per cent.	5.1	9.9	6.7	1.4	2.2	trace
Pb, per cent.	26.6	67.3	12.4	4.8	30.8	5.8
Zn, per cent.	11.2	9.7	19.4	16.0	16.8	16.8
Ag, oz. per ton	13.1	30.1	9.6	6.5	28.5	8.3

TABLE 3. SIZING ANALYSIS OF JIG PRODUCTS

Sieve	Coarse Jig				Fine Jig	
	Feed Per Cent.	Concentrates Per Cent.	Middles Per Cent.	Tails Per Cent.	Concentrates Per Cent.	Tails Per Cent.
Caught on 20.	16.2	14.0	12.8	29.2	.8	22.3
Caught on 40.	31.4	41.6	34.9	36.5	26.6	36.6
Caught on 60.	17.1	19.6	22.8	13.0	25.8	18.7
Caught on 80.	11.5	10.4	12.8	7.2	15.2	10.4
Caught on 100.	8.0	7.9	8.8	5.1	16.5	6.1
Caught on 120.	4.0	3.0	2.8	2.6	7.1	2.4
Caught on 150.	4.3	1.9	2.2	2.2	4.6	1.6
Through 150.	7.5	2.2	2.9	4.2	3.6	1.9

V. F. Stanley Low* gives two interesting tables showing that, for coarse jigs, the tailing caught on 100 and coarser mesh sieves contained 2.2 per cent. to 3.2 per cent. lead, and that through 100 mesh contains 9.6 per cent. to 12.7 per cent. lead, and for fine jigs 4.4 per cent. to 7.1 per cent. lead and 11.4 per cent. to 15.7 per cent. lead, respectively. The above figures show that the hydraulic classifiers are far from effecting a clean separation of slime. At the Broken Hill Proprietary Co.'s mills the tailing from both the coarse and fine jigs are passed over shaking screens, the oversize going to the dump and more recently to the grinding plant, and the undersize to the zinc plant (Delprat flotation process). This simple expedient greatly lessens the percentage of lead and zinc going to the dump.

Considerable diversity of opinion exists as to the method of treatment of fine ore and slime, ranging from attempts at close and careful classification to almost none, though in most cases there is a more or less serious attempt at classification. Generally the treatment is as follows: The fine ore and slime from various sources, e. g., hydraulic classifiers, overflow from jigs, or fine screens (as at the Junction North), are passed to spitzkasten or pointed boxes with a regularly increasing cross-section toward the overflow end. The coarser material from the earlier spigots is treated on Wilfley, Card, or Krupp tables, the latter spigots on belt vanners of the Luhrig or Warren types. The end spigot may be treated on vanners or sent direct to the slime-settling pits. Companies which have not their own plants to treat the slimes make a more serious attempt to save the utmost amount of values on the tables and vanners. The heads from the various concentrating tables or vanners are concentrates to be sent to market or to the company's smelter. The middlings are generally classified and treated on separate concentrators, giving concentrates and tailings. It is generally accepted that retreating middling on the same table without reclassification is defective practice. The coarse tailing goes to the dump. The slime, which runs straight down the table, is in many cases kept as a separate table product, sent to a thickening box, and thence treated or sent direct to the slime pits. It was early recognized that a high percentage of lead in the tailing from tables of the Wilfley type was contained in the slime, which ran straight down the table. This has led to making a coarse and slime tailing product, the former carrying little value and going directly to the dump, and the

latter being thickened or retreated, or saved and transformed into a product that can be smelted in blast furnaces. Tables of the Wilfley type are recognized in Australia not only as good concentrators, but also as excellent slime separators. Slime products are being obtained for further treatment in the manner mentioned not only in the concentration of lead, but also of gold and tin ores.

The notable example of the non-classification of fine ore and slime is the Broken Hill South mine. Here the middling product of jigs is reground in pans of the improved Wheeler type. The whole product is directly treated on Wilfley tables, which give concentrates to market, middlings back to pans, tailings to dump, and slimes which are thickened in boxes and treated on vanners which give concentrates to market and tailings to dump. It is found that the most of the lead is recovered when the ore is ground to pass 100 to 150 mesh. It must not be overlooked that undoubtedly good results, claimed to be the best at Broken Hill, are obtained at this plant. The new 6,000-ton mill is built directly for this system of treatment. At the Broken Hill Proprietary Co.'s plant four products are obtained from the Wilfley and similar type tables and from the vanners, viz., concentrates, middlings, coarse tailings, and slimes. The middlings of the Wilfleys are retreated on other Wilfleys, giving concentrates, tailings, and middlings, the latter being retreated on the same table; the vanner middlings are run into spitzkasten, and thence on to the vanners, giving concentrates and tailings. The coarse tailings from the Wilfleys and vanners are run out into a spitzkasten to remove the small amount of slime left in them, and then sent to the zinc plant for further treatment by the flotation process. The slimes are settled, dried, heap roasted, and sent to the Port Pirie to be smelted. The slimes of most of the other companies are, for the time being, a waste product.

Tables 4 and 5 are analyses of Wilfley and vanner products:

TABLE 4

Mesh	Wilfleys				Vanners				Settled Slimes
	Feed Per Cent.	Concentrates Per Cent.	Middles Per Cent.	Tails Per Cent.	Feed Per Cent.	Concentrates Per Cent.	Middles Per Cent.	Tails Per Cent.	
Caught on 20.	17.3	1.6	2.7	2.4	3.3				nil
Caught on 40.	32.8	1.6	2.7	2.6	3.3				1.2*
Caught on 60.	15.6	1.6	2.7	10.7	3.3				3.2*
Caught on 80.	15.6	2.3	17.6	18.1	2.9	1.5	3.3	1.1	15.5*
Caught on 100.	10.5	4.6	11.8	16.4	3.5	1.5	3.3	1.1	14.6*
Caught on 120.	16.3	13.0	20.0	16.2	2.6	6.5	3.3	1.1	18.3*
Caught on 150.	43.7	75.8	37.0	32.6	89.0	93.3	59.8	45.2	1.6*
Through 150.									96.2

* Contains wood pulp.

TABLE 5

	Wilfley Tables				Vanners				Settled Slimes
	Feed	Concentrates	Middles	Tails	Feed	Concentrates	Middles	Tails	
Insoluble, per cent.	40.0	28.0	36.0	46.0	35.0	13.0	34.0	48.0	31.0
FeO, per cent.	4.4	2.9	5.1	7.0	8.1	4.4	8.1	6.8	8.1
CaO, per cent.	3.2	2.1	1.8	4.5	2.2	3.4	3.8	2.9	3.4
Pb, per cent.	21.4	48.2	19.8	4.9	15.8	57.1	5.1	4.4	20.0
Zn, per cent.	16.8	6.2	19.0	16.8	17.6	9.2	20.8	17.3	16.3
Ag, oz. per ton	13.8	28.9	15.4	8.9	16.9	29.6	15.7	9.5	18.7

The economical recovery of the blende as a marketable zinc concentrate has been the greatest problem which has confronted the technical men of Broken Hill during recent years. Much money, time, and ceaseless patience have been bestowed upon the solution of this problem. As previously mentioned, Broken Hill ores always contain varying quantities of garnet and rhodonite, in addition to galena and blende, also other minerals of less importance. The high specific gravity of galena enables a large percentage of that mineral to be readily

recoverable by the skilful use of jigs, concentrating tables, and vanners, but no such use can be made of these appliances to make a separation of blende from the garnet and rhodonite into a marketable concentrate. The Broken Hill garnet has a specific gravity about 4.2, the blende about 4, and the rhodonite about 3.6. The garnet can frequently be seen on Wilfley tables and vanners, making a distinct reddish band



FIG. 5. BROKEN HILL PROPRIETARY MINE, BLOCK 14

slightly in advance of but blending into the body of blende, while the rhodonite hopelessly overlaps and mingles with the blende, the quartz often forming a distinct whitish band in the rear.

As it was hopeless to seek a solution by wet concentration, it was sought in a different quarter, viz., by magnetic concentration, and later by flotation processes.

The Australian Metal Co. erected a magnetic concentrating plant known as the Zinc Works, at which concentrates were made at intermittent periods. Ulrich machines, designed by the manager, were installed and used. About 8 years ago an experimental plant, using Mechernich machines, was installed at the Central mine, where, with additions, it has been working until very recently. The great drawback of these magnetic processes, apart from any economical considerations, is the amount of fine dust set free into the atmosphere, despite precautions made to keep the mills free from it, the result being an unusual amount of sickness due to lead poisoning among the employees.

The Mechernich machine is composed essentially of two bar electromagnets. The properly crushed and dried material is fed from a chute into the strong magnetic field between the adjacent north and south poles, the upper one (north) revolving. The intensity of the field gradually decreases after passing the adjacent surfaces. The ore is brought in contact with the poles at its strongest field. The paramagnetic particles adhere to the upper or revolving poles, while the diamagnetic particles fall off, and are collected in a bin. The paramagnetic particles are carried round by adhering to the pole into a constantly diminishing intensity of field, until they are dislodged by gravitation or some mechanical means. Each chute may be adjusted to suit the required conditions at the various zones of release.

It has been found that, under the influence of a powerful magnetic field, garnet and rhodonite are much more susceptible than blende, and the latter more so than galena and quartz, which are practically non-magnetic. With suitable machines three products may be made.

1. Garnet rhodonite product to waste.
2. Blende product, which may be further cleansed on another machine.
3. Galena blende quartz products, which are readily separated on wet concentrating tables and vanners into lead

concentrates and a small amount of zinc concentrates and quartz to dump.

The scheme of reduction shown in Fig. 8 outlines the process used at the Central mine.

In 1901 C. V. Potter, of Melbourne, took out a patent for the recovery of sulphides from their ores by the addition of very dilute acidulated solutions to finely pulverized ores, which causes certain sulphides to rise to the surface.* Sulphuric acid is for economical reasons used of a strength from 1 to 10 per cent. Dilute sulphuric acid will not attack galena or blende to any extent. During the early days of the process the following was supposed to be the action that took place, viz., that acid attacked the sulphide of iron (FeS), which was always present in small quantities, liberating sulphuretted hydrogen (H_2S).



The liberated bubbles attached themselves to the sulphide particles, and when large enough lifted them to the surface. By heating the solution less acid is consumed on account of the expanded bubbles having a greater buoying-up power. When the bubbles break, the particles fall again. Various appliances have been devised to remove the floating particles from the bath before the bubbles break.

This Potter process has not been a financial success in its original form, but has suggested other acid flotation processes, some of which are working with a high degree of success.

In 1902 G. D. Delprat, the general manager of the Broken Hill Proprietary Co., Ltd., took out a patent for the Delprat or salt-cake process. In this process salt cake or crude acid sulphate of soda $NaHSO_4$, is dissolved in water until its specific gravity is increased to 1.3. Sulphuric acid is added to the solution, heat is applied, and the solution and fine ore particles are treated in vats as hereafter described. Reactions similar to those in the Potter process take place, but it was very soon discovered that the real chemical reactions were different from those previously assumed to take place. It was at once observed that the process was free from the distinctive odor of sulphuretted hydrogen. On examination, the gas given off was found to be CO_2 , with a trace of H_2S . The CO_2 was given off from the small amount of calcite and siderite always present. The



FIG. 6. CONCENTRATING MILL, JUNCTION MINE, BROKEN HILL

liberated CO_2 attaches itself to the clean particles of sulphides, but not to earthy or oxidized surfaces. If concentrates which have been produced by an acid flotation process are retreated by themselves, the reactions are feeble, and but a small amount is recovered unless calcite or a similar carbonate is added to the flotation vats. The material treated in the Broken Hill Proprietary Co.'s zinc plant is derived as follows from the lead concentrating mills: The tailings of both coarse and fine jigs are passed over shaking screens, to separate the coarse siliceous

*See Aust. Mining Standard, August 21, 1902.

part from the finer material containing a fair percentage of lead, zinc and lead. The former is sent to the dump, and the latter, mixed with the tailings from the Willey table and the tailing vanners, are passed through a spitzkasten to remove slime. The coarser product is sent to the zinc plant, and the slime product to the slime-settling pits.

One of the special features of this process is the use of the Delprat patent vat. This vat is a steeply inclined inverted



FIG. 7. WORKSHOPS, NORTH MINE, BROKEN HILL

wooden pyramid lined with sheet lead. The vat has two pockets, one with and the other without an outlet. The blind pocket allows the ore particles to overflow steadily into the outlet pocket and at the same time collects lumps, etc., which might obstruct the outlet. The outlet is regulated by a stopper on the end of a rod, which passes down through the solution. The solution is made up in a vat and heated by a steam coil to about 180° F. The solution passes, by means of a pipe, to near the bottom of the flotation vat, into which the fine ore is fed automatically above the fluid pocket. The gas generated attaches itself to the galena and blende particles, floating them to the surface and overflowing with the excess solution into a settling vat common to several flotation units; while the gangue—principally quartz, rhodonite, and garnet—escapes through the outlet in the pocket on to an endless belt, where it drains sufficiently to allow it to be sent away, to be used for refilling stopes in the mine. The concentrate settles in the tank till it is full, when the stream is diverted to a similar tank, while the former is drained and the solution returned by air jet to the solution tank. The concentrate is then given a water wash to remove any chemical solution, and then drained. The vat concentrate may be retreated to increase the percentage of zinc, and at the same time to recover some of the galena as a lead concentrate. This may be done on Willey or similar tables and vanners, or, for preference, by magnetic concentrators, as the latter give richer concentrate. Some magnetic concentrators are adapted to treat wet material. The zinc and lead concentrate is then sent away for metallurgical treatment elsewhere.

Tables 6 and 7 are an analyses of the feed, concentrates, and tailings of this process.

De Bavay process makes use of the selective actions of CO_2 in attaching itself to sulphides but not to earthy particles. The CO_2 is generated externally.

The Ballot, or granulation, process was formerly known as the Cattermole process. This is an acid-oil flotation process. The H_2SO_4 is added for the purpose of cleaning the surfaces of the particles of oxidized ore, as oil does not adhere to oxidized or earthy surfaces. With freshly broken sulphide the process is said to work well without acid, but the additional acid assures cleaner surfaces, and hence a better separation. The feed, usually tailing, is ground fine in ball mills or grinding pans, the pans giving best results. This ground pulp is then fed con-

tinuously without sizing to the agitation vat, where up to 3 per cent. H_2SO_4 is added in a thin stream, and about .05 per cent. of oleic oil is added. A large range of oils can be used.

TABLE 6

	Feed	Concentrates	Tailings
Insoluble, per cent.	49.0	8.0	65.0
FeO, per cent.	7.3	10.0	4.4
CaO, per cent.	3.9	2.7	4.1
Pb, per cent.	3.6	5.8	2.7
Zn, per cent.	16.4	14.1	5.1
Ag, ounces per ton.	15.3	37.9	2.9

TABLE 7. SIZING ANALYSIS

Sieve	Feed Per Cent.	Concentrates Per Cent.	Tailings Per Cent.
Caught on 20	.7		1.9
Caught on 40	6.1	4.0	8.4
Caught on 60	10.7	15.5	14.3
Caught on 80	17.8	16.5	16.1
Caught on 100	23.8	20.2	23.3
Caught on 120	12.9	12.7	11.3
Caught on 150	11.2	11.3	13.2
Through 150	16.8	20.0	11.9

After passing through the agitators the pulp passes through three spitzkasten separating boxes in series. The ore particles are floated over the lips, while gangue passes into the next for retreatment, and from the third is discharged into settling tanks, where the solution is decanted, and the drained tailings are sent to dump. The action is as follows: The acid cleans the surface of the metallic sulphides; the oil attaches itself to the clean sulphide surfaces, the agitation causing numerous small air bubbles to be carried down and held in suspension in the pulp, until they attach themselves to the greasy surfaces. The pulp then coagulates into little lumps, hence it is termed the granulation process. The concentrates assay, on the average: Zinc, 43 per cent.; lead, 11 per cent.; silver, 17 ounces. The percentage of zinc is moderate, and that of lead is so high that it might be advantageous, for both metallurgical and economical reasons, to put the granulation process concentrate through magnetic separators to remove a portion of the lead as a separate lead concentrate, as is found advisable in the Delprat process.

This process has the great advantage of giving good results in the presence of slime and has been installed on a large scale

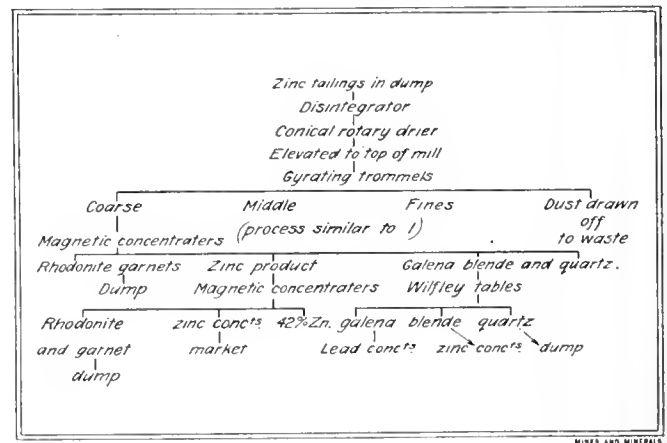

FIG. 8. BROKEN HILL CENTRAL MINE PROCESS

at the Central mine, Broken Hill, for the continuous treatment of tailing. The flow sheet of this mill deserves special attention, as the process is continuous, giving lead concentrate, zinc concentrate, and worthless tailings.

The vacuum oil process has recently been introduced at the Zinc Corporation Works at Broken Hill.

The process is based (1) upon the fact that in flowing pulp of crushed oil and water, oil has a selective action for the mineral particles as distinct from the rocky particles or gangue. (Thus far it follows the original Elmore process.) The selective action is materially increased in some cases by the presence of acid (a modification made since the introduction of the Potter process). (2) Upon the fact that the air or gases dissolved in milling water are liberated, partly or entirely, upon subjecting the same to a pressure less than the surrounding atmosphere. These liberated gases may be augmented by the generation of gases in the pulp (as in the Potter process or the Delprat process), or by introduction from an external source (as in the De Bavay process). These liberated gases attach themselves to the greased mineral particles (as in the Cattermole process), and, being largely increased in volume as a result of the vacuum or partial vacuum applied thereto, cause the greased particles with their attendant bubbles of air or gas to float to the surface of the liquid from which they are automatically discharged in the form of a rich concentrate leaving clean tailings in the bottom of the vessel in which the operation has been conducted. The application of a vacuum to increase the floating power of the adhering gas is distinctly novel to this class of process, and takes the place of the simple expedient of heating the solution as in Potter, Delprat, Cattermole, etc., processes.

The crushed pulp from a wet crushing mill is mixed with oil and acid in an agitator. It is thence under the influence of a partial vacuum drawn up into a vacuum separating pan. The metalliferous scum overflows from the top of the separating pan, and is drawn down a long length of water-sealed pipe into a tank. The tailings are likewise, by suitable machinery, raked to the outer edge of the vacuum pans and discharged into a tank in a similar manner to the concentrates.

It is claimed that this process, like the Cattermole process, successfully deals with slimes mixed in the pulp.

It is very desirable in operating ore-dressing mills to sample and assay not only the crude ore entering, and the products leaving, the mill, but also to know the assay value of the various intermediate products at successive stages. It enables the mill superintendent to daily analyze the work under his control, and also to localize the blame on any shift or individual for indifferent results, e. g., one man on each of the three shifts looks after the same, say three jigs. Samples of concentrates and tailings for these jigs go to form one average sample of concentrate, also of tailings for each shift. Each sample should be separately assayed, and the result posted in the mill. Blame may then be localized on individual operators, the moral effect of which is good. In all cases the tonnage is determined by weighing each truck of ore before it is tipped to the breakers.

There are two general methods of determining the average assay value of the crude ore. In the first and more rational method the ore fed to each set of rolls is sampled, say a scoopful of the total stream, i. e., coarse and fine, is taken at intervals, say, of $\frac{1}{2}$ to 1 hour, the total quantity going to form the average sample of the mill for the 8-hour shift or the 24-hour day. The average assay value of crude ore is fairly uniform and not patchy. The average assay value taken in conjunction with the weighed tonnage gives a firm basis to calculate the total metal contents of the crude ore, and hence, later on, after the metal contents of the product have also been ascertained, to determine the actual and percentage recovery of lead, zinc, and silver. The other method in use is to weigh or estimate the weight, sample, and assay the products, and thence by back calculation to determine the average assay value of the crude ore. This method is defective, in that it is difficult to sample and weigh the slime slurry going to temporary waste, except by the round-about and uncertain difference in the total weight in balancing the total of the other products against that of the crude ore. The final products have high percentage of moisture when

sampled. There is thus a large amount of balancing and calculation to ascertain the value of the crude feed which can be more readily and directly ascertained. It should not be overlooked that the mines using the back calculation of values usually show on paper better percentages of recovery than those directly sampling the crude feed. The intermediate products, such as the concentrates and tailings of jigs, tables, and vanners, are sampled by diverting the whole stream from the launder into a drum, a short length of launder or sheet metal being used for the purpose. The product is allowed to settle, the excess water poured off, and the sample placed with its own cosamples to form the average sample for the shift. The shipping value of concentrates is ascertained by sampling with an augur each truck if shipped loose, or each bag if bagged. The samplings are placed in a drum provided with a close-fitting lid to prevent evaporation of moisture until the bulk sample is quartered down and the moisture per cent. ascertained. Bulk samples are quartered down in the same way.

It might be well to state that the percentage of rhodonite in the ores varies very considerably at different parts of the lode. The following is said to be a fair average percentage of rhodonite in the ores of the following mines:

	Per Cent.
North Mine, rhodonite.....	3
South Mine, rhodonite.....	7
Broken Hill Proprietary, rhodonite.....	15
British, rhodonite.....	25
Junction, rhodonite.....	35
Junction North, rhodonite.....	45

In crushing, the rhodonite, i. e., manganese silicate, is left in large rounded grains, while quartz and the metal-bearing minerals, especially galena, have a great tendency to slime. These variations in the composition of the ore, which at first sight appears small, greatly affect the physical condition of the ore, and have resulted in considerable modifications of the treatment at different mines.

采 采

Shaft Gate—Strong Mine, Victor, Colo.

The shaft gate shown in the accompanying sketch is in use at the Strong shaft, Victor, Colo. The bar *B* is made of 4"×8" timber or of any other convenient size. It is pivoted at *H* by a bolt upon the head-frame leg *A* and at the opposite end fits into the rest or catch *G* of $\frac{1}{2}$ "×3" iron. *F* is a counterweight of the proper

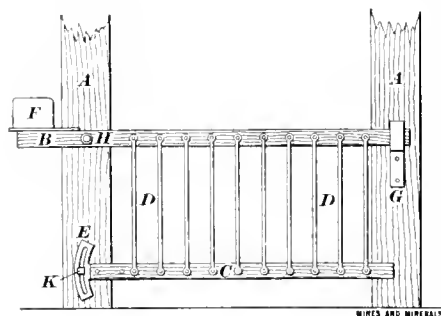

SHAFT GATE

weight of the proper heaviness and distance from *H* to permit of the gate being raised or turned on the pivot *H*, by a very light upward pull.

Suspended from the bar *B* by means of the rods *DD*, etc., is the lower bar *C* which may be made of lighter material than *B*. The rods

DD, etc., are flattened at the upper and lower ends and bolted to both *B* and *C* so that they may turn freely.

Attached to the inner side and on the left end of the bar *C* is a slotted plate of thin iron, through which the bolt *K*, set in the leg *A* passes.

When the bar *B* is raised by an upward pull near *G* it revolves on the bolt *H*, and the rods *DD*, etc., turn on their upper and lower pivots and the plate *E* turns downward on the bolt *K*, the whole gate being, if the term is allowable, collapsed or compressed.

The gate is very simple, can be made by any mine carpenter at a reasonable cost, and is absolutely effective.

The Burt Revolving Filter

Description of the Method of Construction and Operation. The Efficiency Attained

The Burt rapid cyanide filter was invented by Edwin Burt when in charge of the cyanide department of the El Oro Mining Co., El Oro, Mex. This is especially adapted for treating slow-settling slime which usually contains a large percentage of colloidal substances.

The Burt revolving filter, a more recent invention, is designed for handling granular slime, a mixture of fine sand and slime, or similar material, which will settle quickly and form cake readily. Both are pressure filters, the compressed air used ranging from 25 to 40 pounds per square inch, depending upon the physical conditions of the material to be treated. If local conditions will permit, the slime may be made to flow by gravity direct to the filter from the slime agitation tanks, or if this is not possible the slime may be elevated sufficiently high above the filters to give the desired pressure. If conditions are such that it is impossible to adopt either gravity method suggested, then a pump may be used to force the slime into the filters from the agitation tanks

and furnish the desired pressure. The Burt revolving filter, shown in Fig. 1, resembles a tube mill from the exterior, the feed end of which is supported on a trunnion *a*, while the other end is supported on the rollers *b*. The slime and wash water are charged through the hollow trunnion and the cake is discharged through the cast-iron door *c* operated by the hydraulic cylinder *d* and the system of levers *e* attached to the piston rod *f*. The filter cloths are made 28 inches wide by 10 feet long, there being five cloths in a circle. These cloths are interchangeable and held in place by the angle irons shown in Fig. 2, the irons being slipped over studs fastened in the shell at the place where two filter cloths meet. In the upper part of Fig. 2 the filter shell relative to the discharge opening in the shell is shown. Each filter cloth has its individual outlet at the center of the filtered solution. The coating which forms on the cloth due to lime put in the solution of cyanide to neutralize acidity is removed whenever necessary without removing the cloth by giving it an acid wash from time to time. There are 25 filter leaves in a 40-foot revolving cylinder and any one can be changed in a few minutes.

During the cake-forming period the filtrate passes through the filter cloth and out through holes in the shell on to a cement floor, from which it flows to a receiving sump. The end period of cake forming is ascertained by the filter blowing air rather than water through the holes in the shell.

The discharge door, with opening and closing attachments, is shown in Fig. 3, and consists of a cone-shaped casting *a* to which one end of each of the six toggle arms *b* is fastened and held in position relative to the end of the filter shell by means of heavy rods or bolts that are surrounded by

springs *c* which aid in closing the discharge door. The door is opened and closed by means of the piston in the cylinder, hydraulic pressure being used for the purpose. From one end of each of the six toggle arms *b* a lever *d* extends from the toggle joint to the center of the piston rod on which is located a large iron collar *e*. When the springs push the door shut the ends of the six levers converge toward the piston rod, and being in the path of the collar, as the piston rod is allowed to slide through the door a few inches after it is shut, the collar comes in contact with the ends of the levers, pushing them forward, thus straightening out the toggles and exerting a tremendous pressure at six different points of the door. In the course of operation, the discharge door being closed as shown in Fig. 3, slime is fed into the cylinder by means of a valve in the trunnion. After a proper charge has been admitted to the cylinder the slime valve is closed and an air valve opened; then from 25 to 45 pounds of air pressure is admitted to the cylinder and maintained until all the slime has gone to cake. The air is now shut off and wash solution is admitted. In case there is sufficient hydrostatic head to the wash solution to overcome the pressure of air in the filter, it is allowed to enter at once, but if there is little head to the solution the escape valve to the filter is opened and the pressure dropped sufficiently to permit the washed

solution to enter the cylinder. The required amount of wash solution is run in, after which the valve is closed and more compressed air used to force the wash solution through the cake. When the filter starts blowing, the air pressure is again turned off and wash water is admitted to the cylinder in the same manner as the wash solution, and when the filtering operation is finished, the air pressure is removed and the door opened in order to dis-

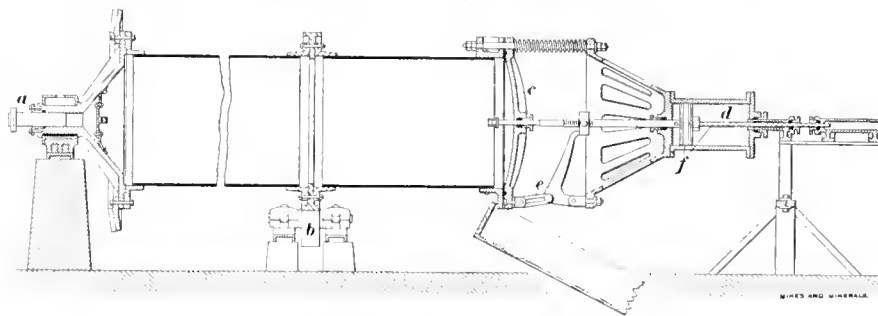

FIG. 1. SECTION, BURT REVOLVING FILTER

TABLE 1. SCREEN ANALYSIS OF FILTER FEED

Mesh	Percentage
+ 100	2.6
+ 150	23.2
+ 200	8.4
- 200	65.8

charge the cake. Little water is required in discharging slime cake, it being necessary only to add enough to make the canvas slippery so that when the cake forms into a round loaf it will slide in, and move toward the discharge door. This water is added in a small amount at one time, just as the cake falls, and is estimated to be about 100 pounds per ton of dry slime.

When operating this filter it is revolved continuously at 15 revolutions per minute.

In Fig. 4 the washing efficiency of the Burt revolving filter is shown in diagram made from tests conducted at El Oro, Mex. This diagram shows the average rate of removal of gold, silver, total value, and cyanide during washing, with the quantity of barren solution in tons per ton of dry ore per day. The number of charges put through a filter is 13, the average thickness of the cake produced is 4.3

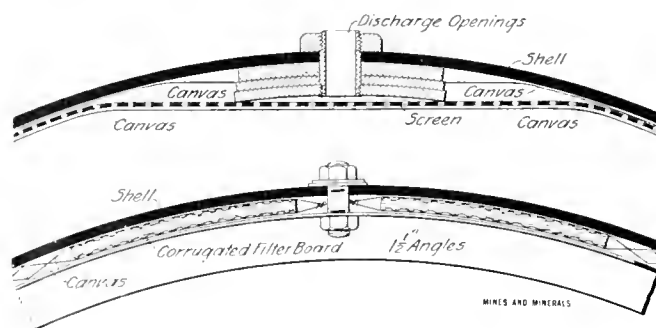

FIG. 2

What Brazil Offers Prospectors

A Country Known to Contain Gold, Silver, Platinum, Iron, Manganese, Diamonds and Other Gems

By George H. Mee

Glancing at a map of Brazil one finds a country covered with almost a net work of rivers, their basins being divided by long mountain ranges, whose altitudes vary up to 7,000 feet, tending north and south, with the exception of the central plateau, where the ranges run in all directions.

One of the highest of the Brazilian mountains, the Itatiaia, some 9,000 feet high, is composed chiefly of hornblende, syenite, tuff and clink-stone, characteristic of ancient volcanic centers.

It is impossible to fully describe the mountain system and the immensity of the country, so ancient, and at the same time so new and unknown, for until the nineteenth century gold was almost the only mineral mined in Brazil.

One of the principal ranges of mountains, known as the Espinhaco or in English, the Backbone, is noteworthy from the fact that the older crystalline rocks, gneiss and granite, are subordinate to the series of ancient metamorphic schists, quartzites, and limestones, and to a later series of sandstones and conglomerates.

The older crystalline and metamorphic rocks are sharply folded and the newer series rest unconformably in gentler folds on their upturned edges, forming the mountain peaks most predominant in the Espinhaco, some of which attain 6,000 to 7,000 feet.

In this series of mountains the metamorphic schists are rich in iron, manganese and gold ores, whilst the sandstone series is in places diamondiferous.

A flexible sandstone called itacolumite is a characteristic of the districts of Diamantina, Grao Mogul and Minas Novas in the state of Minas Geraes and also in certain districts in Bahia.

It is difficult to point out any particular locality as being better worth prospecting than another, as the whole of the

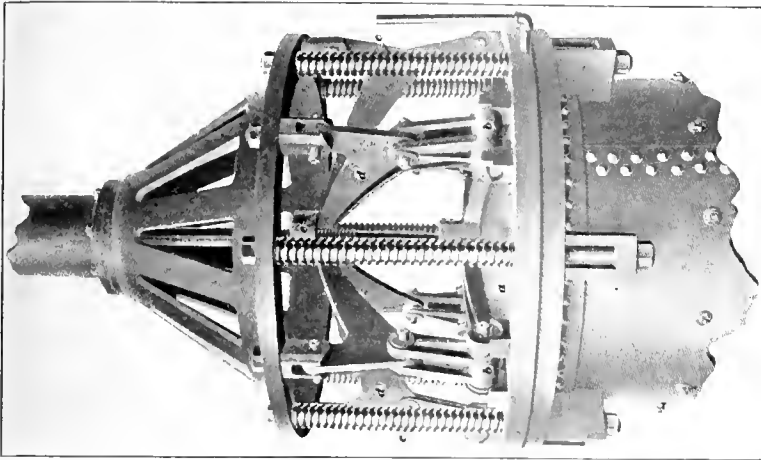

FIG. 3. DISCHARGE DOOR MECHANISM

inches; the average dry metric tons treated per charge is 5.24; the average pressure per square inch during the caking period is 38 pounds; the average pressure per square inch during washing is 48 pounds. The table on page 234 is given as an average screen analysis of filter feed used for the tests.

The average percentage of colloidal matter in the material fed to the filter was 38.4. The ratio of solids to liquid and pulp fed to filter was 1 to 1.126. The extraction during filter pressing was, gold, 22 cents; silver, 1.1702 ounces; total value, 80 cents.

The advantages claimed for the Burt revolving filter are that the discharge door opens wide and will admit a man to inspect the filter shell and do any necessary repairs; that there is no excess slime solution or water to be handled; that the filters can be driven from any convenient shafting or by small motor, as very little power is required; that little water is needed for discharging; that the filter requires about one-fourth to one-half of the power required to operate the vacuum filter, due to there being neither surplus slime, barren solution, wash, or wash water to return, as everything that goes into the filter comes out through the filter leaves and the shell except the solid slime.

In Fig. 5 is shown a battery of three Burt revolving filters in operation at the El Oro Mining and Railway Co.'s operation, El Oro, Mex. These filters are revolved at 15 revolutions per minute continuously during the operation of filtering a charge. At this plant they are filter pressing and washing over 27,000 tons of ore monthly with 2,400 square feet of filter surface. In the revolving filter $\frac{1}{2}$ -inch thick cake is formed in a minute or two, the balance, 3.8 inches on an average, forming on this quickly owing to the air pressure inside the cylinder forcing the solution out of the slime.

來 來

Uses of Soapstone

Laundry tubs, griddles, foot-warmers, and many other similar utensils are manufactured from soapstone. The higher grades of massive tale, free from flaws, are sawed up to make pencils or crayons, French chalk, gas tips, and many special articles.

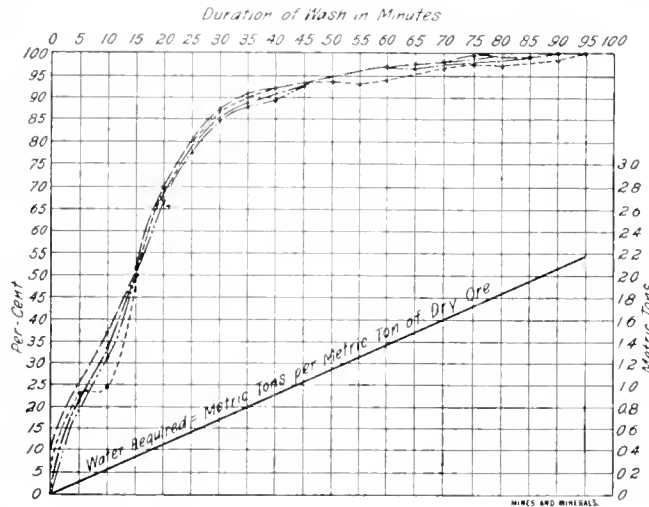

FIG. 4

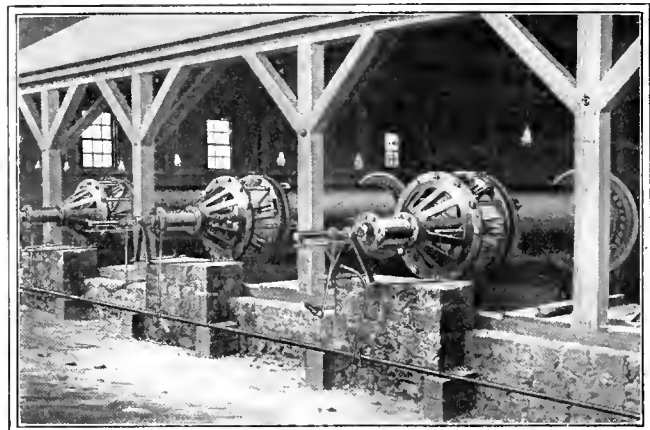

FIG. 5. BATTERY OF REVOLVING FILTERS AT EL ORO

Epinhaco and its offshoots is auriferous. The state of Minas Geraes is the most important center of the gold-mining industry, although it has already been fairly well exploited. One of the richest and principal mines in the state, the Morro Velho mines yields \$125,000 in gold monthly, and its expenses are about \$60,000.

This mine, the deepest in South America, is over 4,250 feet deep.

The most promising speculation is placer mining, by means of dredging and hydraulic sluicing of the high banks of gravel left by ancient miners in many localities. The upper portion of the River Doce, Rio de Contas, Pardo, Paraguassa River and the Itapicuru, all falling into the sea between Espirito Santo and the Sao Francisco, are well worth prospecting; for both gold and diamonds.

The minerals usually associated with gold and diamonds in the deeper gravels, and as yet untouched, are porphyrites, chalcedony pebbles, black tourmalines, rutile, hematite, magnetite, and emery.

In spite of nearly 350 years of mining, hardly a month passes without some lucky find is reported. In 1909, nuggets were found at Montes Claros that weighed from 1 ounce to $1\frac{1}{4}$ pounds, and a diamond found at Dos Dourados in Minas weighed nearly 18 ounces, and was of the first water.

Something should be said of the diamonds found in Brazil. The most famous is the Estrella de Sul, which is 254 carats, and was found in the Bagagem River. The Dresden diamond is 177 carats, and the Coroa de Portugal 120 carats.

As stated, the river gravels are most productive of these stones in the state of Minas Geraes, the principal rivers being the Abaete, Bagagem, and Cocaes.

In the state of Bahia they are found in the Sincora and Lencoes district and at Salobro, 2 feet below a white clay decomposing soil, also in the Itapicuru River in the gravels.

Only a very small area of the alluvium has been explored and most of the river gravels are untouched at 20 to 50 feet below surface of the water, and at the very least the gravels contain enough gold to pay for the dredging.

Coal mining in Brazil seems to be in its infancy. The total thickness of the thin beds of coal at Tubera in Santa Catherina, is about 10 feet and they grade between lignite and ordinary bituminous coal. In Para there are small coal deposits, but of no commercial value. The Santa Catherina coal is suitable for making briquets and about half can be used in the ordinary way.

Manganese ores in Brazil average 45 per cent. of the minerals of commercial value, are remarkably free from sulphur and phosphorus, while iron is found everywhere.

Graphite is found in veins varying from 20 to 40 inches thick, near the Jequitinhona River, but it is not as yet mined.

In the state of Minas, galena is found in calcareous, or in quartz veins and is always argentiferous. It occurs near Diamantin, Caethe, Sete Lagoas, Montes Claros and Abaete. This Abaete deposit has been assayed, and produced 40.25 per cent. lead with about 6 ounces of silver to each 200 pounds of the metal.

Platinum is found in many of the rivers in small quantities, and zinc as a sulphide is found in the granite rocks.

Quicksilver is found in Brazil, but to no great extent.

Silver is found in various parts of the country, but the industry has not been developed, although that it was recovered by the early Spanish explorers might be assumed by the fact that some 20 years ago a relative of the writer was engaged in removing some of the contents of an old Spanish ship, which had been sunk in a few fathoms of water off the coast of Rio de Janeiro. Using a complete diving equipment, he secured at great personal risk a large number of silver coins besides a few gold pieces and other trinkets.

Amongst the collection of big brass keys and other things, were two broken ingots of silver about 4 in. x 8 in. in diameter and very roughly molded.

No authentic statement could be made as to the age of the wreck, but it was believed to be at least two centuries old.

The Brazilian mining laws are based on the best features of those elsewhere and the taxes payable are from $\frac{1}{2}$ per cent. to 10 per cent., with the exception of the taxes for monazitic sands which are very heavy, but it is claimed that the profits afford sufficient recompense for this import.

The beds of monazitic sand extend from the south of Bahia to Santo Espirito, and the two main deposits are in the hands of concessioners who fix the price for oxide of thorium, there are other deposits, however, that are as yet unworked.

A large quantity of copper is mined in Rio Grande do Sul (Camaquã) and in Bahia in the vicinity of Sao Francisco River, Maranhao, and Santa Catherina district.

Amethysts are found in many of the states and even within a few miles of the city of Rio de Janeiro, in the decomposed rocks of granite base. These stones are principally found in Bahia, Minas, Minas Novas, and Rio Grande do Sul, where the great Drusy cavity was found by German agate miners. Some 15 tons were taken out and exhibited at Dusseldorf in 1902, the crystals being an inch long and of the deepest violet color. This mass was found in a coastal range at 2,000 feet above sea level. Some amethysts have been found half yellow and half violet.

Green tourmalines are found in the Riveriras de Tolha, near the Chapada Dimantina, and fine blue, yellow, white and pink gems are found at Minas Novas.

It may be stated that all the northeast of Minas is noteworthy for the abundance of this crystal, and some of it is found with green ends and pink center.

Yellow topaz is found in a short range of hills close to Ouro Preto, in the flexible sandstone, itacolumite, and clay slate. Rock crystal is plentiful in Minas and is more or less common in all the states.

Agates may be found in the Rio Grande do Sul, as rounded pebbles in the rivers, and almost every variety is encountered including crocidolite, or tiger eyes, carnelians, and onyx.

Persons who have lived in Brazil claim that the adventurer has nothing to fear from the climate, and the government report on the death rate per 1,000 in 1908, was only 20.2.

Nevertheless malarial fevers are found in the Amazon valleys and several Americans, known to the writer, were stricken with the disease known as beri-beri which causes the limbs to swell from the feet up and causes death on reaching the cardiac organs. The only reliable cure for this is an immediate ocean voyage which will invariably arrest the progress of this disease if it is not too far advanced.

The bulk of menial labor in Brazil is performed by the Guarani Indians, who are generally strong husky fellows, but the bulk of the population is crossed in all directions, the natives having mingled foreign strains amongst themselves until by far the greater proportion are divided into the following groups: Mulattoes, Mamelucos (descendants of aborigines and white men), the Cafuzos (crossed between negroes and Indians). The lowest type of Indians found in Brazil are the Tupi, who although nearly disorganized, still keep up hereditary feuds, plunder and murder whenever opportunity occurs, and avoid contact with foreigners and despise their inventions.

Transportation is improving every year and new railroads are under construction, while at present there are 12,000 miles of track in use with all modern equipment, the completion of the roads will almost double the present railroad facilities.

Like all other South American Republics, Brazil suffers from too frequent changes in its government, but in spite of all the drawbacks it is being rapidly developed in the most modern and up-to-date manner, and there is still plenty of space not yet explored, for those who hunger for pioneer work and are willing to take a few chances.

A Spanish Iron-Ore Treatment Plant

Method Employed at a Spanish Mine for Briquetting Fine Iron Ores Without the Use of a Binder

By Special Correspondent

At the present time there is a growing tendency owing to the gradual exhaustion of iron producing areas and the growing scarcity of iron ores, to combat the increasing difficulty of securing supplies by endeavoring to utilize the finer ores which formerly were considered unsuitable for the needs of iron works, and by suitable processes of briquetting to convert them into a condition suitable for the blast furnace. The last 20 years, and particularly the latter half of the period mentioned, have been particularly fruitful in the application of experimental methods on a practical scale to the briquetting of iron ores without the use of binders.

The briquetting of iron ores has been attempted by methods which may be classified into processes using organic binders, such as pitch, tar, or other substances, processes utilizing hydraulic lime or some other binding material of a calcareous nature, processes adopting the use of clay, and lastly, but by no means least, those processes which do not use any binding material whatever, but which depend on the softening and agglutination of the particles of the mass under a heating process. This latter method, which is one which in practice has been found to be most successful, is the one which it is proposed in this article to describe and illustrate by particular reference to the process adopted by the Alquife Mines and Railway Co., Ltd.

The screening and briquetting plant of this company is erected at Guadix, in the province of Granada, Spain, and was constructed by Messrs. Sutcliffe, Speakman & Co. Ltd., of Leigh, Lancashire, England. The plant has been sufficiently long in operation for an estimate to be formed both of the technical and financial success of the process. It has been found that properly made briquets have power to resist a high crushing strain have a high specific gravity, and are very porous. Hence, they are in the best mechanical condition for the furnace. Further, sulphur, even when contained by the raw ore up to 5 per cent. can be eliminated during the process down to a content not exceeding .01 per cent. The briquets in general are much richer in iron than the raw ore, due to the elimination of carbonic acid, sulphur, combined water, and other volatile matters; in some instances this enrichment is as much as 12 units of iron. When properly burnt in a neutral or oxidizing atmosphere, the oxides exist in the ferric state, leaving them in a condition the most favorable for reduction in the furnace. It has been proved by actual practice that the use of briquets

increases the output of the blast furnaces, and it has also been proved that a blast furnace working on briquets requires less fuel to operate. From the above it will be seen that the value of briquets cannot merely be taken to be the same as lump ore; their special qualities are such that they demand a special basis of value. As instances of the result of briquetting,

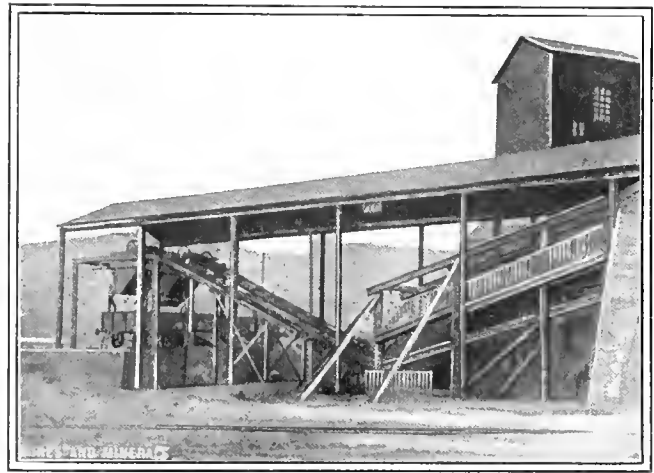

FIG. 2. ORE SCREENING PLANT

the following analyses of Spanish ores before and after treatment are instructive:

RAW ORE WHEN DRIED AT 212 DEGREES	
Iron.....	54.31
Silica.....	5.09
Combined moisture.....	13.75
Iron in same ore as received from mine.....	46.58
RESULTS AFTER BRIQUETTING	
Peroxide of iron.....	85.74
Peroxide of manganese.....	1.54
Silica.....	7.98
Metallic iron equals.....	60.02
Sulphuric acid.....	.20
Phosphoric acid.....	.10
Alumina.....	2.85
Actual sulphur contents.....	.98

Crushing strength, dry briquet, 92 kilos per square centimeter; wet briquet, 89 kilos per square centimeter; porosity, 6 per cent. of water absorbed; tensile strength, perfect, same in the interior as the exterior.

The results from another Spanish ore are interesting. The dried ore before briquetting contained, iron, 47.91 per cent.; manganese, 4.55 per cent.; silica, 11.48 per cent. While after briquetting the constituents were: Iron, 53.45 per cent.; manganese, 5.15 per cent.; and silica, 12.25 per cent.

The Sutcliffe process, adopted at the Alquife plant, consists in mixing the ore with a suitable proportion of moisture, afterwards turning it into briquets in powerful presses, and burning the briquets in suitable kilns. Fig. 2 is the ore-screening plant, Fig. 3 the entrance to the briquetting kilns, while Fig. 5 shows the briquets as they are brought from the tunnel kilns.

Some classes of ore do not require any particular preparation, being already in a proper condition for feeding direct to the briquetting press, such ores as purple ore and some pyrites coming under this class. Other ores require the addition of moisture, which can be effected in a differential mixer. This consists, as made by one firm, of two shafts running in opposite directions in a suitable trough, one shaft revolving at twice the speed of the other. The knives are cast iron, fitting over square shafts, the ends being chilled. Again other ores are improved by being ground, mixed, and kneaded in an edge-runner mixing mill, whilst others again are improved by being finely ground. The object of this preparation is to enable a briquet to be made from the mixed material as dense and solid as possible, as the denser the briquet going to the kiln, the less fuel is

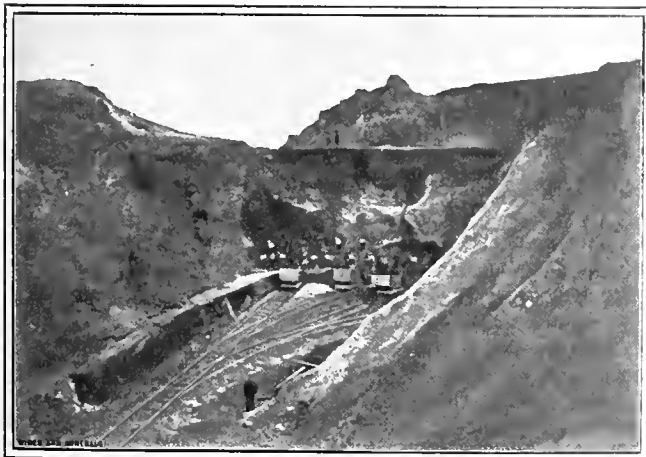

FIG. 1. LOWER PART OF SAN JOSE MINE, SPAIN

required to burn it. The reasons for this are, firstly, that a dense briquet transmits heat more readily than one of less density, even if made from the same material, and the burning is achieved just when a certain temperature is attained; hence, the more readily the briquet takes up the heat, the quicker it is in burning. Also the result of the burning is to soften the

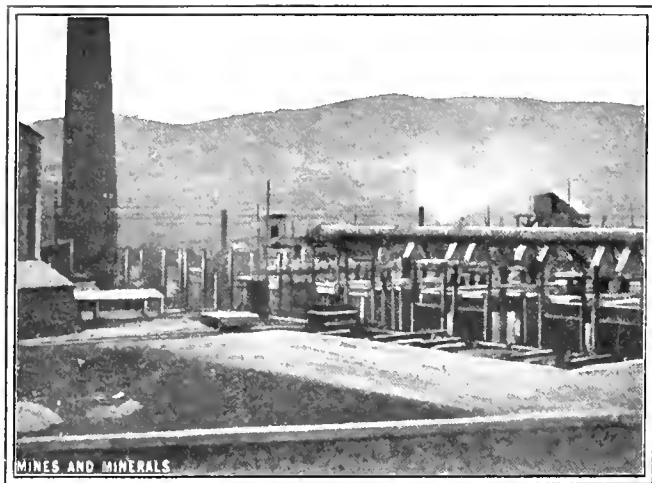

FIG. 3. ENTRANCE TO BRIQUETTING KILNS

particles of the ore until they stick together, and the closer the particles are together, the more readily they will agglutinate. The density of a briquet is much affected by the amount of moisture used in the preparation of the material, thus in some cases high percentage is required to get a dense briquet, while others are better if pressed in a dry condition. Again, some ores are in a cellular condition and require breaking

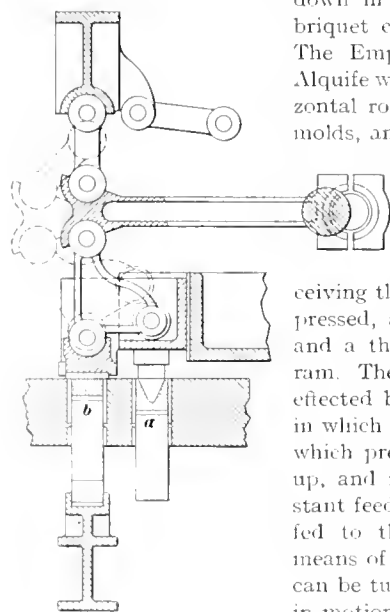

FIG. 4

down in a pan mill before a dense briquet can be pressed from them. The Emperor presses used at the Alquife works each consist of a horizontal rotating table containing the molds, and, depending on size, there are from eight to twelve molds. The table is rotated one mold at a time in such a manner that while one mold is receiving the charge of material to be pressed, another is under pressure, and a third is under the discharge ram. The feeding is automatic, being effected by means of a circular pan in which revolves a series of stirrers which prevent the material choking up, and insures a regular and constant feed. The quantity of material fed to the molds is regulated by means of a hand wheel, and as this can be turned whilst the machine is in motion, the pressure can be regulated at will. The pressing mechanism is of the toggle and knee type,

and the pressing is so effected that all the strains are on massive steel bolts, thus taking all the greater strains off the frame work. All levers and parts subject to great strains are made from cast and forged steel, and adjustments are made for taking up wear and tear. The molds are easily and quickly relined, and in putting in new liners no fitting or adjustment is required; the liners go direct into place, and thus the time taken up in relining the molds is reduced to a minimum. Furthermore, each set of liners can be reversed, giving two wearing faces. All its principal working parts are above the level

of the table, thus preventing wear otherwise caused by sand and dirt falling into the bearings. A patent expression attachment operates by giving each brick two pressings, the first squeezes and presses the material from the center into the corners; the final pressure finishing the brick. By these means each brick is of even density throughout, with fine sharp corners. This arrangement is shown on the sectional drawing in Fig. 4. The mold receiving the first or preliminary pressure is shown at *a* and the final pressure at *b*. The working pressure of the machine is 100 to 150 tons, and the power required to operate it is from 5 to 10 horsepower. It operates smoothly and easily, and owing to powerful springs is evenly balanced.

The kilns used at the Alquife are of the tunnel type, consisting of a tunnel or series of tunnels 5 feet in width and in length from 150 feet to 200 feet, through which a series of cars are passed, touching each other. The briquets of convenient size are piled in two, three, or four layers on the top of the cars. The loaded car is then pushed in at one end of the furnace, a car load of burnt briquets being simultaneously forced out from the opposite end of the furnace. The sides of the cars are fitted with deep flanges which run on a trough on each side of the inner wall of the furnace, which troughs are kept filled with sand, thus ensuring the furnace being air-tight. The space below the cars is thus entirely closed off from the chamber above the cars. The cars are also covered with a thick fire-brick covering; hence, damage to the car wheels or axles is entirely prevented. The combustion chamber is situated near the center of the furnace, and the arrangement is such that the products of combustion pass over the incoming briquets, to which they impart their heat, while the briquets, after passing the combustion chamber enter the cooling section and are cooled by the entering air of combustion.

The economic value of the processes above described is undeniable. Perhaps some additional interest is given to the matter in connection with Spanish minerals in that there is no doubt that an exchange trade to Spain, say with either finished American goods or even coal as an export, and the briquetted ore as an import, should be of advantage to American industry. Quite apart from that, however, the extension of knowledge with regard to the economical treatment of badly paying ores is a distinct asset, and such as will be of interest to mining engineers.

來 來

Natural Salt Deposit

There is stated to be a large natural deposit of Epsom salts on the international boundary line at Bitter Lakes in the Similkameen Valley below Keremeos, near to the Great Northern Railway, containing, it is estimated, some 70,000 tons, 98 per cent. pure. A shipment of 44 tons is said to have been recently sent to Spokane and analyzed as stated.

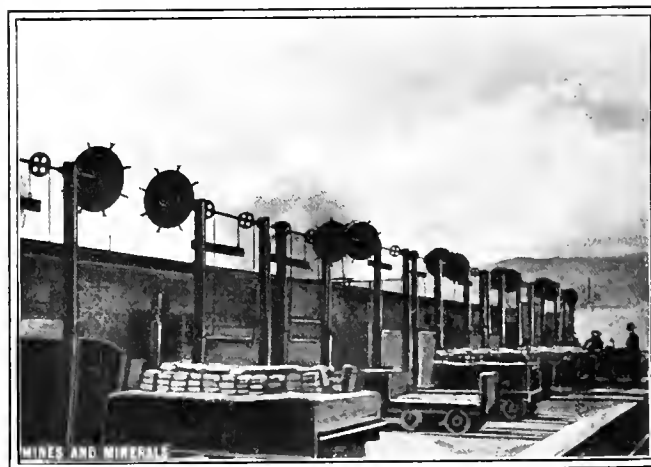

FIG. 5. BRIQUETS COMING FROM KILNS

Air-Lift Agitation of Slime Pulp

The Relative Merits of Air and of Mechanical Agitation in the Operation of the Cyanide Process

By E. J. Laschinger, M. E.*

[NOTE.—This article, while part of a criticism on a paper presented to the Chemical, Metallurgical, and Mining Society, of South Africa, by Robert Allen, M. A., B. Sc., contains so many practical hints and suggestions it becomes at once of interest to every cyanide man. Mr. Allen advocated air rather than mechanical agitation. Mr. Laschinger does not approve of this at the present stage of cyaniding because he considers that knowledge on the subject is deficient.]

If the problem on the one hand is simply to bring particles of ore into thorough contact with cyanide solution, or to keep ore from settling in water or solution, or on the other hand to also bring air for the purpose of supplying free oxygen to this intimate mixing process, the two cases are not on a par when considering simply the most economical means of agitation. If air be necessary as a chemical adjunct, it is self-evident that subsidiary mechanical stirring is superfluous if the air by its method of introduction can perform the mixing at a reasonable cost without other aids.

Mr. Allen has not proved his case in favor of air agitation in a satisfactory manner, because he has not even attempted to differentiate between the various cases above mentioned.

It requires a certain amount of power to compress air, and this power can be accurately determined. Theoretically, the minimum work required to compress air from atmospheric pressure to any other pressure is by isothermal compression; i. e., without rise of temperature during the process. The work thus required to compress a cubic foot of air is:

$$(1) \quad \text{Work in ft.-lb.} = 144 P_a \log_e \frac{P_1}{P_a}$$

Where P_a is the absolute atmospheric pressure in pounds per square inch, P_1 is the absolute pressure of compression; i. e., gauge pressure plus atmospheric pressure, say, $P_g + P_a$.

The horsepower required per cubic foot of air at atmospheric pressure compressed per minute is therefore:

$$(2) \quad \text{H. P.} = \frac{144 P_a}{33,000} \log_e \frac{P_1}{P_a}$$

For conditions at sea level with a barometric pressure equal to 14.7 pounds per square inch, we have:

$$(3) \quad \text{H. P.}_s = .0642 \log_e \frac{P_g + 14.7}{14.7}$$

For conditions on the Rand with average barometric pressure equal to 12.1 pounds per square inch, we have:

$$(4) \quad \text{H. P.}_r = .053 \log_e \frac{P_g + 12.1}{12.1}$$

The above gives the theoretically minimum figures of power required. In practice there are power losses in compression, friction losses in the motor and compressor, heat losses in compression, and leakage losses past valves and pistons. The over-all efficiency of small compressors is probably not more than 50 per cent.; even in large compressors the total efficiency will not be much greater than 65 per cent. Assuming an all-around efficiency of 60 per cent., the actual power required will be one and two-third times the figures given by formulas (2), (3), and (4). In Fig. 1 are isothermal compression curves which show the power required to compress 10 cubic feet of air per minute from atmospheric pressure to 40 pounds per square inch gauge pressure. Curve S shows the theoretical horsepower required at sea level, and curve R the same for average Rand conditions; curves S_1 and R_1 the corresponding power with an over-all efficiency of 60 per cent.

Before using this diagram to criticise certain figures quoted

by Mr. Allen a digression is made to point out a few distinctive features of air agitation. A glance at the diagram shows that it requires less work to compress a cubic foot of air at atmospheric pressure (generally called "free air") to any given gauge pressure on the Rand than at sea level. If it be assumed that the amount of work got back from the compressed air in stirring the pulp is equal to the work put into it in the two cases, the conclusion is that for the same amount of agitation more volume of free air would have to be used on the Rand than at sea level to produce the same mechanical effect. The amount of air used on the Rand would have to be increased in inverse proportion as the work per cubic foot is greater at sea level than on the Rand.

If a certain amount of air be required to satisfy chemical reactions, then the air required must be measured by weight and not by volume. Since air at sea level averages 13.2 cubic feet per pound, and on the Rand 16 cubic feet per pound, it follows that in order to deliver the same weight of air 21½ per cent more volume of free air must be compressed on the Rand to furnish the weight of air that would be delivered at sea level. For this case, therefore, the amount of power required would also be greater on the Rand than at sea level. Curves of power required for equal weights of air delivered would on the diagram

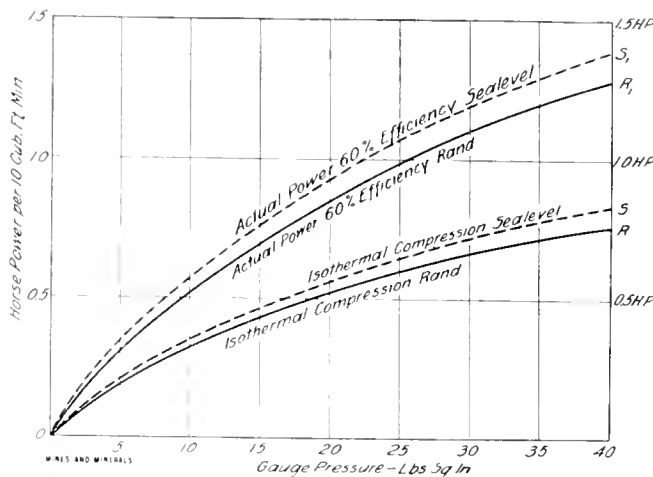

FIG. 1

show the R curve above the S curve. In general the above reasoning is true for different altitudes.

It may also be of interest to discuss the point as to how much of the power put into the air is really effective as mechanical work in agitation. Air agitation in a Brown or Pachuca tank with the central pipe is the reverse of hydraulic air compression. In tests made on this form of compression the over-all efficiency ranges between 70 per cent. and 80 per cent. It may be assumed that the same ratio holds good in air agitation. The over-all efficiency of air agitation from work in the motor to agitation in the vat is therefore $.60 \times .75 = .45$, or 45 per cent.

Taking now Mr. Allen's first table of average results of experiments by F. C. Brown, and assume for argument sea-level conditions, then for comparisons, taking the quantity of air used as correct:

	Per Table	From Diagram
First case horsepower.....	$\frac{3}{4} - 1$	1.1 - 1.4
Second case horsepower.....	$\frac{1}{2} - \frac{1}{2}$.4 - .6
Third case horsepower.....	$1\frac{1}{2} - 2$	1.6 - 2.2
Fourth case horsepower.....	$1\frac{1}{2}$	3.9

In the fourth case the theoretical horsepower required works out at 2.4, therefore, the amount of power quoted, namely, $1\frac{1}{2}$, may be dismissed in certain familiar words of our old friend Euclid.

*Johannesburg, South Africa.

In actual practical design a liberal allowance on the power required as found from the diagram should be made.

With regard to the power required by the Pachuca system, there is simply the statement that "pulp containing 100 tons of dry slime to 150 of solution can be treated with $4\frac{1}{2}$ horsepower."

Figuring out the probable power consumption for the air lift agitation in the Luippard's Vlei plant as quoted by the author, say, 85 cubic feet of free air (presumably per minute) at between 25 and 30 pounds per square inch gauge pressure the diagram gives from 8.3 to 9.3 horsepower, probably from 9 to 10 horsepower in actual practice.

The above proves that either the horsepowers quoted by Mr. Allen are wrong, or that the quantities of air as given are not correct.

In discussing the remarks anent mechanical stirrers, such as "clumsiest constructions," the necessity of "digging out the paddles after a short stoppage," it might be pointed out that mechanical devices need not be clumsy, and paddles need not be dug out if the machinery be designed properly.

Mr. Kniffen, in "Methods of Pulp Agitation," says that "if the ore only requires that fresh molecules of cyanide be brought continually to the particles of metal, and that the air which is included in the solution be sufficient for the reaction, there is no system at present better than arm agitators, raised a few feet above the bottom of the tank, and driven at 800 feet per minute at the outer ends of the arms."

In these remarks I do not advocate mechanical stirring gear rather than air agitation, but in the present state of knowledge there is no doubt but that mechanical devices and air agitation have each their sphere of usefulness in metallurgical processes.

Simple circulation of pulp could be carried out economically by means of a centrifugal pump specially constructed and used for that purpose only. As an example, it would be possible to turn over the whole of the pulp in the Luippard's Vlei vat every 50 minutes at a cost of no more than from 6 to 8 horsepower.

The trouble in the past with most centrifugal pump circulation and agitation has been that the pump has been used for other purposes besides circulation, as for instance, in transferring charges against fairly large heads. The pump was necessarily speeded up to deal with the maximum head, and is therefore very wasteful of power when circulating. The wear and tear on the pump also increases at a more rapid rate than the increase in speed. The over-all efficiency of a low-lift circulating pump, motor, and piping system should be about 50 per cent.

It is probable that the subject of air agitation *vs.* mechanical agitation will turn more on maintenance and capital cost than on power cost.

With regard to the general results found by F. C. Brown, the statement that "the higher the tank compared with the diameter the less the power required," is incomplete, the probable meaning being that this is true only for equal weights of pulp handled. The statement then falls into line with theoretical considerations. For if the height be doubled the same volume of free air is still only required for agitation at slightly less than double the gauge pressure. This means that the absolute pressure is not doubled, and as the work required does not increase at the same rate as increase in pressure, but only as the logarithm of the pressure ratios, considerably less power per ton of pulp treated is required.

Regarding the statement of there being less cyanide consumption with deep than with shallow vats, this result may also be expected to follow partly from the argument, but also because in a deeper vat, owing to the higher pressure of the air, chemical action between the air, the cyanide, and the pulp is more rapid, and the total time of reaction is thus also reduced. On the law that the intensity of chemical reaction is proportional to the mass density of reagents present, it follows that doubling air

pressure doubles its density, and the total time is cut in half. Less total air per weight of cyanide present will be required, since only a very small proportion of the total oxygen supplied is really used up by the cyanide, and so again there will be less loss of cyanide by oil, etc., which is carried by the air supply.

There is, however, a very practical point to be considered in fixing the total height of a vat, that is the expense of filling the vat by pumping, because, theoretically even, only half the work done in pumping the vat full can be regained in emptying it, and in practice generally the whole of this power is lost. There is also to be considered the extra cost of building strong tall vats and furnishing suitable foundations to withstand the heavy strains, wind pressure, etc.

A good practical rule of thumb in regard to pressure of air required is to take the figures representing the total depth of the vat in feet and divide this by 2, which will give the pounds square inch gauge pressure required. For example, over-all depth 40 feet requires gauge pressure 20 pounds per square inch. If air be used at a pressure much greater than that so calculated, there is bound to be a serious waste of air, and probably inefficient circulation.

The maximum amount of cooling of the pulp charge due to the expansion of the air used can be readily calculated. If air be allowed to expand while doing work and no heat is added or abstracted during the process, the ratios of the absolute initial and final temperatures are given by the expression:

$$(5) \quad \frac{T_a}{T_1} = \left(\frac{P_1}{P_a} \right)^{\frac{2}{7}}$$

T_a is the initial absolute temperature ($^{\circ}\text{F.} + 461$) and T_1 the final temperature; P_a and P_1 being the pressure as used in the formula for horsepower as given previously. The amount of heat abstracted in British thermal units would be for every pound weight of air used.

$$\text{B. T. U.} = .24 (T_a - T_1)$$

the figure for the specific heat of air being .24. The specific heat of water is 1, and of rock generally .2. Assuming the initial air temperature to be the same as that of the pulp charge and knowing the quantity of free air per minute used, the calculation becomes simple. For the Luippard's Vlei installation quoted by the author, we have the following data:

$P_a = 12.1$, P_1 average $27.5 + 12.1 = 39.6$, T_a say $70^{\circ}\text{F.} = 531^{\circ}$ abs.

Quantity of air per minute, 85 cubic feet, = say 5.3 pounds; charge of slime, 150 tons; water, 300 tons.

British thermal units required to heat pulp $1^{\circ}\text{F.} = 660,000$.

British thermal units taken by expansion of air per hour, per $^{\circ}\text{F.} = 76$.

Theoretical difference in temperature $T_a - T_1 = 152^{\circ}$.

British thermal units taken by theoretical expansion of air per hour, equivalent to heat abstracted per hour, $76 \times 152 = 11,552$.

Cooling effect on pulp per hour, .0175 $^{\circ}\text{F.}$

It will thus be seen that this effect of cooling is absolutely negligible, and could not in practice be even measured after 10 hours of circulation. This point is mentioned because, although Mr. Allen has not touched upon it, other writers on the subject seem to have made too much of it without going into the matter thoroughly.

In this connection, if warming the pulp be necessary to hasten chemical reaction and solution of gold by cyanide, it would be advisable to introduce a jet of steam with the air, as the heat would then be applied in the initial stage of contact of air, cyanide, and pulp, and should thus be more effective in shortening the time of treatment.

The destruction of cyanide by carbon dioxide should be inappreciable for two reasons. (1) the amount of CO_2 added by normal air is very small. Allowing .06 per cent. CO_2 by weight as usual in air, 100 cubic feet per minute supplied amounts to only .22 pound per hour, which would represent .32 pound of potassium cyanide; (2) different authorities say that CO_2 is

not a cyanide in the presence of alkali in solution. In Rand practice, alkaline solutions are always used, quicklime being added for the purpose.

With reference to the air agitation vats at the Geldenhuis Deep, referred to, these were designed 3 years ago. The central pipe was made in telescopic form, so that experiments could be made on the best length of pipe to work with. The plant was finally worked with the upper telescopic pipe as far down as it would go.

Regarding the Luippard's Vlei agitation vat being probably the largest single-charge vat in the world, there are two air-agitation vats installed at the City Deep, Ltd., designed in 1909. Each vat is 32 feet in diameter, 30 feet in height of cylinder, with 8-foot depth of cone, or 38 feet high over all; each vat treating from 250 to 300 tons of dry slime at a charge. The central pipes, 16 inches in diameter, extended about two-thirds of the way up. Air for both vats is supplied by a small compressor belted to a 25-horsepower motor so as to have spare power for emergencies. An emergency air supply pipe is connected to the regular mine air service pipe.

Mr. Allen has suggested that the question of turbo blowers in series to supply air might be looked into, so as to avoid atomized oil in the air. In the present state of engineering science, small blowers would not be nearly so economical as reciprocating compressors. Oil troubles can easily be avoided by proper attention to the lubrication of the compressor cylinders. Soapy water can be used at intervals for lubrication instead of oil, and the oil can be thrown down by a water spray in a suitable receiver, and the combined oil and water emulsion drained off by a suitable trap before the air is delivered to the vats.

The advantages of the shorter central pipe, which advantages are treated of in an article by A. J. Jager, were realized in the City Deep design, more especially the two main points, that it is possible with the shorter pipe to commence operations before the vat is full, and that aeration is more thorough when a thick body of pulp lies over the top of the pipe. In fact, at the City Deep the air can be advantageously turned on when the vat is only one-third full. The air bubbles in the central pipe are comparatively large as they rise, but when they strike the more solid body of pulp over the mouth of the pipe the air is broken up and intimately incorporated with the pulp. With the pipe debouching at or near the surface of the pulp there is a violent disturbance in the center and comparative quiet round the outer circles, but with the pipe opening deeper down, the whole pulp looks whipped and light, and the general appearance of the surface is like a mushroom top, with continuous motion of the pulp from the center to the sides.

Since air agitation is still a young process on the Rand, doubtless it will develop on lines peculiar to local requirements, and Mr. Allen deserves the thanks of the society and local mining circles generally for bringing this matter up for discussion at the present time.

來 來

Denver, Colo., was located on the possibilities which Cherry Creek had to offer, first as a camping ground for transcontinental immigrants, next as a settlers' camp, then as a possibility for gold, and finally as a midcontinental city. It is an historical creek, concerning which it is said among other things, that the name boomer was derived. Be that as it may, if reports from Newlin's Gulch prove true the long-sought for original source of the gold in Cherry Creek has been discovered. What is said to be a dike carrying gold has been uncovered a short distance above the old diggings where there has recently been a revival of activity. The dike is reported to be 8 feet in width, and has been traced for a distance of 40 feet. The belief that the gold of the placers came from this dike is supported by the fact that none is found above the place where the dike is located.

Time Keeping at Crystal Falls

Methods of Recording and Checking the Reports of Time-keeper and Foremen

By James D. U'iclan

The following paper was presented at the Lake Superior Mining Institute in August, 1911, under the heading "Time-Keeping System of the Crystal Falls Iron Mining Co.":

In the employment of the number of men necessary to operate a mine, the employer is compelled to introduce a system of time keeping which will insure accuracy in the work, not only as to the distribution of the labor cost to the proper account, but also as to the correctness of the time credited to each employe for the work performed. Many different systems are used at the mines in the Lake Superior district, each

MINE			
DAILY LABOR AND PRODUCT REPORT			
191			
Surface	Total	Underground	Day Night Total
1 Office, Time, Shipping and Supply Clerks		1 Mining Captain and Ass'ts.	
2 Mining Engineer, Chemist and Ass't.		2 Mine Foreman	
3 Master Mechanic		3 Miners, Company Acc't	
4 Machinist and Hlprs.		4 Miners, Contract	
5 Engine House Floor-man		5 Trammers, Company Acc't.	
6 Brakemen		6 Trammers, Contract	
7 Firemen		7 Car Dumpers and Skip Tenders	
8 Pumpmen		8 Trackmen	
9 Pipemen		9 Timbermen	
10 Carpenters		10 Ditching and Cleaning Tracks	
11 Carpenter's Helpers		11 Underground Laborers	
12 Blacksmiths		12 Mule Teamsters	
13 Blacksmiths' Helpers		13 Car Brakemen	
14 Drymen and Janitor		14 Chutemen	
15 Ladders, Pocketmen, and Rock Pickers		15 Wheelers	
16 Stock Pile Trackmen		16 Motormen	
17 Stock Pile Motormen		17 Motor Brakemen	
18 Stock Pile Laborers			
19 Barn Boss and Helper			
20 Teamsters-Swampers			
21 Crushermen - Crusher Engineers			
22 Surface Foremen			
23 Surface Laborers			
24 Painters			
25 Wood Choppers			
26 Steam Shovel Oprtors			
27 Steam Shovel Lbors.			
28 Masons			
29 Electrician			
30 Boiler Makers and Helpers			
33 Total Men	21 Total Men		
	22 Product per Man		
23 Total Number Men Employed			
24 Product per Man			
Number Cars Trammed			
Number Skips Hoisted			
Number Tons Hoisted			
Total Product to Date for Month Days			
Average Daily Product for Month Days			
Estimate for Month Days			
Cars Shipped from Stockpile			
Summary of Hoist		Day	Night
25 Number Cars Trammed	{ No. 1 Shaft No. 2 Shaft No.		
26 Number Skips Hoisted	{ No. 1 Shaft No. 2 Shaft No.		
27 Number of Skips Rock Hoisted			
28 Tons Ore Hoisted			

(Reduced from the Original)
FORM "A"

* Crystal Falls.

of which has some good points, and it is with the idea of bringing out a discussion of the various systems that this paper is presented at this meeting. The best method is one by which a check can be had on the person keeping the time, to provide safeguards against carelessness and dishonesty.

An employe is liable to be mistaken in the number of shifts that he claims to have worked during the month, and should he claim more than the timekeeper shows, a check system against the timekeeper will prove or disprove his claim. The same system would be equally effective should an employe think he had worked less time than his due bill called for. It would not be just to deduct a certain number of shifts, when a checking system might show that the employe had not kept his own time correctly.

In order to provide as many safeguards as possible, the time-keeping system adopted by the Crystal Falls Iron Mining Co., as explained herein, will show that the system has a tendency to keep not only the timekeepers in line, but also the several foremen or bosses, by whom the time is kept.

The men on going to work in the morning, report their brass check numbers to the timekeepers (at our mines this is done verbally), who record them as the men present themselves at the window. The timekeeper, in taking the numbers in this manner, sees each man, and knows that the man has gone to work, whereas, if the numbers were to be deposited by the men themselves one man could deposit more than one number, and later in the shift, those for whom he deposited could slip into their working places. On returning from work at the close of the shift, the men report again in the same manner to the timekeeper.

During the shift (we are working two shifts of 10 hours each and have a timekeeper for each shift), the timekeeper sees every man at his work. On surface he makes two rounds each day, once on each half shift. Underground the timekeeper makes only one round each shift, and as he meets the men he records the place in which they are working. This enables him to classify the time according to the accounts kept or classification required for cost reports, etc. The timekeeper at the close of the shift has a good check on his own work, and taking for granted that he has faithfully performed his duties as required, the possibility of an error is remote.

Form A is the form of daily report made by the timekeeper and transmitted to the general office. This is given to show the similarity of the checking report (Form C) made out by the different foremen.

The surface foreman takes the time of the men employed on the surface, regardless of what their employment or connection with any particular branch of the organization may be. The shift boss takes the time of the men underground, likewise regardless of the work they are doing. These several bosses, therefore, take the time of all men employed around the mine.

Each foreman makes out a report for his shift, the surface foreman being obliged to get the time of the few men employed at night, when no regular night surface foreman is employed. He takes each man's number orally, and at the close of the shift fills out a blank having the check numbers on it in consecutive order, making a cross (X) after the number corresponding to the brass check number of every man whose time he has taken.

On the reverse side of this report, as shown by Form C, he makes a general classification of the men working on his shift. This classification is considered incidental to the real purpose of the report, i. e., getting a check on each man who worked on that particular shift.

This report, as made out each day by shift boss or foreman, is then placed in an envelope, sealed, addressed to the superintendent, and mailed to the general office. The bosses and timekeepers are, under no consideration, to compare notes on the time, under penalty of dismissal. These reports, as received at the general office, are checked against the report

of the timekeepers, and at the end of the month, against the total days of the pay roll. In all cases they must agree.

Assuming that a discrepancy should occur between the timekeepers and foremen, a blank (Form D) is provided to be used in checking, to find where the error was made. This blank, when filled out, is referred by the general office to the captain of the mine, whose duty it then is to take the books of the timekeeper and shift boss or foreman, and in their presence check the same to locate the error. This is an easy matter and quickly done. The blank is then filled out as directed and returned to the general office and filed with the reports.

All men are paid by the cashier of the general office, the timekeepers not doing any paying. It has been found that men who were generally classed as the habitual kickers on pay days are not now heard from, as they know that when they get their due bills their time is correct, and there is no further cause for a complaint.

The method above described has been in use since the early part of 1902, and has proven very effective. At the time the reports were first introduced at the older operating mines, the shift bosses objected to the clerical work involved, but once fairly started, it has had no drawbacks and is in general favor.

Mine,		191			
Surface	Total	Underground	Day	Night	Total
Office, Time, Shipping and Supply Clerks		Mining Captain and Ass'ts			
Mining Engineer, Chemist and Assistants		Mine Foreman			
Master Mechanic		Miners, Company Acc't			
Machinists and Helpers		Miners, Contract			
Engine House Floorman		Trammers, Company Acc't			
Brakemen		Trammers, Contract			
Firemen		Car Dumpers and Skip Tenders			
Pumpmen		Trackmen			
Pipemen		Timbermen			
Carpenters		Ditching and Cleaning Tracks			
Carpenters' Helpers		Underground Laborers			
Blacksmiths		Mule Teamsters			
Blacksmiths' Helpers		Car Brakemen			
Drymen and Janitor		Chutemen			
Landers, Pocketmen and Rock Pickers		Wheelers			
Stock Pile Trackmen		Motormen			
Stock Pile Motormen		Motormen Brakemen			
Stock Pile Laborers					
Barn Boss and Helper					
Teamsters—Swampers					
Crushermen—Crusher Engineers					
Surface Foremen					
Surface Laborers					
Painters					
Wood Choppers					
Steam Shovel Operators					
Steam Shovel Laborers					
Masons					
Electrician					
Boiler Makers and Helpers					
Total Men		Total Men			
		Grand Total Men			

(Reduced from the Original)
FORM "C"

CRYSTAL FALLS IRON MINING CO.
.....191.....

Captain.....
.....Mine

Dear Sir:
The following discrepancies appear on the Daily Report of.....
.....191.....

Daily Report	DAY	NIGHT	REMARKS
Shift Boss
Sur. Boss
.....
.....

Please locate the discrepancies and return this slip with your findings.

W. J. Richards, Gen. Sup't.

REPORT:

Captain

FORM "D"

Mines in Pioche, Nevada, District

Mineralogical Conditions as Shown in the Development of Some of the Principal Mines

By R. M. Bell*

The early operators attached very little value to the porphyry ore deposits, from the fact that when first encountered the ore was too base for treatment in their pan-amalgamation mills. When the Yuba and Mazeppa ore shoots were worked, the clean, high-grade lead carbonate smelting ores were most eagerly sought, and a great deal of the valuable second-class ore was left in the stopes, and the extensive unexplored portions of this porphyry lode is likely to prove one of the most valuable assets and important sources of profit to its owners.

Several eminent engineers who have visited Pioche consider the Yuba dike as the primary ore source or mother lode of the district; and that the rich values of the parallel and lateral quartzite fissures will unite with it at a little farther depth below the 1,500-foot level.

This is a feature that may prove of great economic importance to the district, as this great dike has been identified on its strike to the west at short intervals on the Harrison, Abe Lincoln, Morgan and other claims; and at Stampede Gap, 10 miles west, what is believed to be the same dike with similar fissuring and alteration occurs, and is associated with bands of the rich lead-silver and gold rocks, which opens up a stretch of promising territory for investigation. In addition to this, recent development has shown that the Pioche uplift is traversed by at least half a dozen similar dikes of altered rhyolite.

One of these great dikes traverses the north foot of the uplift half a mile north of the Yuba dike for 4 miles, with a strike north 50 degrees west. At the Ely Valley mine it outcrops 50 feet wide and carries a network of porous quartz stringers that may mean important mineralization at depth; and at a point 1,000 feet south of this ore on the Jefferson claim, another great dike occurs, that is fully 20 feet wide, with a similar strike and a southwesterly dip. Both these dikes should traverse the adjoining Pioche Metals Co.'s ground, where some rich lead ore has recently been developed.

Half a mile south of the Yuba dike, at Pioche, another big intrusion of similar soft altered porphyry traverses the properties of the Pacific and California Pioche Mining companies, where it has been opened in several shallow cuts in limestone and shows a strike of N 70° W, and along the west base of the uplift another altered dike was cut in the Golden Prince shaft, where it is associated with an immense ore body of iron gossan rich in gold, silver, and lead. This dike is 10 feet wide. It has a strike of N 40° W and can be traced to the north of the shaft on this company's ground for 1,000 feet, and the same

distance south on the Pioche King group. There are also two cross dikes of basalt to the northeast.

Numerous similar dikes of altered porphyry, containing in some instances an interesting development of secondary minerals, including bronze mica scales, hornblende, and chlorite, are exposed in the Highland and Jack Rabbit Mountains and generally in close relation to the ore bodies. Should they prove relatively as rich in metals as the Yuba dike, their economic importance to the district can hardly be appreciated. They will certainly stand considerable investigation to this end.

The Nevada-Utah and the Ohio-Kentucky Mining companies own all the old mines that have made Pioche famous for rich ore production in the past, and amount to a mineral empire of themselves, and with railway transportation and other modern advantages, with their several well-equipped deep shafts, from whence to commence operation on extensive

and proven ore bodies, should be put in shape with very little further capital to become a large and profitable mining enterprise.

Several of the more important claims of these old properties are owned jointly by these two companies, a circumstance that has stood in the way of this operation. A movement is now on foot to turn over the entire property of both companies to a holding company, which is the only logical thing to do, as it would settle all chances of further trouble and warrant the establishment of a big mining enterprise.

Any one familiar with the economic geology of Park City cannot help being impressed with future possibilities of the old mines at Pioche. The famous Ontario mine, at Park City, was worked in a steep quartzite fissure exposed by the erosion of the limestone-shale formations. At the Daly-West mine adjoining and on the same fissure the shale and limestone formations were still intact and richly mineralized with great bodies of very zincy and irony silver-lead sulphide ores.

The situation at Pioche is practically the same. The rich

silver-gold quartzite fissure of the Raymond-Ely-Meadow Valley mines is succeeded to the west in the overlying shale limestone formations with fault fissure bodies of zinc-iron-lead sulphide ores, relatively rich in silver and gold. In the adjoining Greenwood and Susan Duster mines are bodies of clean mineral 15 to 40 feet wide that look from present development as if they might be put in shape to produce 1,000 tons of ore a day with 90 days additional development, that would average 5 to 10 per cent. lead and 10 ounces to 20 ounces silver, together with \$1 to \$3 gold per ton.

It is true that these sulphide bodies present a closer blend of the combined minerals than at Park City and doubtless present a knotty metallurgical problem, but with such combined precious values to work on, and a light shaley gangue, I think the problem is susceptible of successful and profitable solution; and it is no serious stretch of imagination to anticipate that, with the rich oxidized ore resources of the Yuba dike

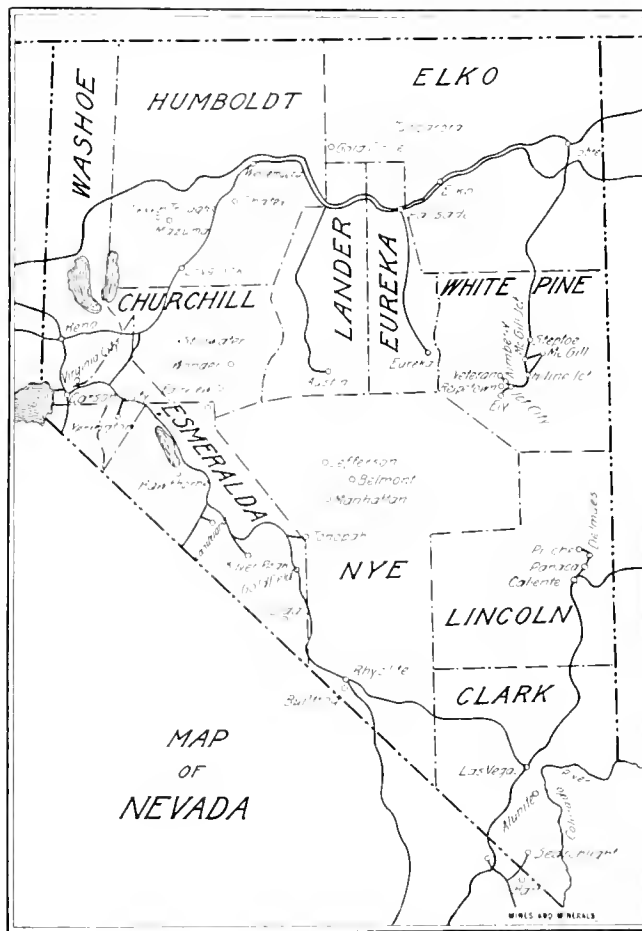

* Former State Mine Inspector, Idaho.

thrown in and the enterprise intelligently gone after, these ore resources will in time repeat the great dividend history of the Ontario-Daly and Daly-West at Park City.

The spotlight of attraction in the current history-making period of Pioche is unquestionably the Prince Consolidated mine. This property is on an entirely different line of fissuring and mineralization from the old mines, and presents one of the most attractive features of the district for rich ore development. The Prince is situated 2 miles south of Pioche and on a fault fissure that traverses the southern border of the Pioche uplift, where it merges into the west valley wash, and it is believed that this fissure has been identified for a distance of nearly 4 miles. It has a strike of N 40° W and a dip of 70 degrees to the south. It is being developed at the Prince mine by a 60-degree incline shaft, now 600 feet deep, from which considerable drifting and cross-cutting has been done at 100-foot intervals.

The shaft at this property is started in a body of black manganese iron oxide in limestone. The extreme surface dimensions of this great body of mineral somewhat interrupted with limestone cappings, show width of 200 feet by a length of 600 feet. Some of the cross-cuts underground are over 100 feet in length, but at no place in these cross-cuts are both walls exposed. It will probably develop a great geyser-like fumarole, or double-chamber deposit, connected with the fault fissure. The foot-wall is well exposed at several points underground and shows a well marked movement breccia—a dip of about 70 degrees to the southwest, and strikes about northwest and southeast.

This great body of commercial ore is now sufficiently developed to warrant the statement that 1,000,000 tons is practically in sight and available above the fourth level, and contains an additional 2,000,000 tons of probable ore when the full section of the deposit is run out at the fourth level. This is an ideal free-smelting ore, as indicated by the following analysis, which is the result of extensive sampling by the company in an effort to get at the average values: Lead, 6.7 per cent.; silver, 4.7 ounces; gold, 40 cents; iron and manganese, 49 per cent.; silica, 12 per cent.; lime, 4 per cent.

This great body of oxide mineral is spotted with bunches, lenses, and stringers of rich carbonate of lead, with occasional cores of galena which are rich in silver, especially the galena, clean samples of which assay over 1,000 ounces silver per ton.

If the oxidation proves as deep here as at Pioche and the selective preference for precipitating rich silver and gold by quartzite walls as compared with the more mixed minerals in the overlying shale and lime, as illustrated at the old mines, is maintained here, some interesting results in the way of bonanza values may be anticipated. When the underlying quartzite is penetrated, this great body of mineral is due to contract in size, but would naturally be expected to show a marked increase in value. The company expects the vein to enter the quartzite at 700 feet.

At a depth of less than 200 feet the ore body passes through the limestone into the main shale beds of the district and has been carried down in this formation 400 feet.

At the 300- and 400-foot levels cross-cuts have been run into the foot-wall formation, where, at a short distance under the big ore body, two parallel fissure veins have been encountered that stand nearly vertical with a slight dip in the opposite direction from the main vein to the northeast.

These fissures have been proven by raises to apex. In the big manganese body 20 feet below the 200-foot level, a gangue of shale breccia in these foot-wall fissures has been changed to high-grade hard carbonate of lead, rich in silver, without changing in color or fragmental structure. They also, in places, exhibit a silicious, sandy gangue and banded structure due to subsequent motion after the ore was formed.

These rich ore courses vary in thickness from a few inches to 6 feet, and an interesting feature is the fact that they carry their richest values in the widest places, where large hand

samples may be picked out well smeared with greenish yellow silver chloride that assay up into the thousands of ounces of silver per ton and several dollars in gold.

These veins, in contrast with their big neighbor, are practically devoid of manganese and iron oxides. They have been developed to a height of 200 feet above the fourth level, where they connect with the big vein, and for an extreme length, so far, of 450 feet, with good ore still showing in all the faces.

This important resource of rich ore is still intact, as no stopping has been done, and the reserve of mineral undercut by the four drifts on the No. 1 and No. 2 fissures at the 300- and 400-foot levels is estimated to contain 14,000 tons. Of the ore taken out in driving the levels and two raises on these smaller fissures, several 40-ton cars have been shipped to the Salt Lake market. The returns received from these shipments have afforded settlement results varying from 100 to 300 ounces silver, \$5 to \$15 gold, and 30 to 45 per cent. lead.

Another interesting feature of this remarkable ore body is that these small foot-wall fissures are connected at the 300- and 400-foot levels with a flat-dipping bedded ore deposit that conforms to the strike and dip of the enclosing shale formations. The lower bed exposed is at the bottom or fourth level, where it is 5 to 7 feet thick and filled with roughly laminated, sandy, brown, iron-stained gangue, associated with thick streaks and lenses of soft sandy carbonate of lead which, however, contrast sharply with the vertical fissure values, being very much lower in silver and gold, but it carries both and shows a combined value of about \$25 per ton across the bed. This lower ore bed has been followed on its flat dip of 15 degrees a considerable distance beyond the No. 2 vertical shaft to the southeast, which would strongly indicate that the source of its ore was in still another vertical fissure in the foot-wall, as ore solutions would be more likely to feed up in a bedded deposit than down, according to the Utah examples of this form of deposits.

來 來

Norwegian Mineral Production

According to the United States Consular Report the export of Norwegian iron ore in 1910 was 75,000 tons, valued at \$201,000, and the shipments of Swedish iron ore from Narvik, Norway, during the year amounted to 2,043,151 tons. The output of the mines at South Varanger, northern Norway, in 1910 was about 80,000 tons of iron ore. A portion of this was smelted by the magnetic process, and in November and December about 10,000 tons were exported. About 400 men are employed in these mines. At the Salangen mines, in the same district, there were produced during the year 25,000 tons of iron ore, of which the larger part was smelted and exported.

The largest copper mine and copper-refining works in Norway are at Sulitjelma. The production of this mine in 1910 was 146,000 tons of ore, and 1,596 tons of Bessemer copper. The United States Consular Report states that there are several other copper mines in Norway which have recently been opened, so it is estimated that the total production of copper in Norway in 1910 amounted to 320,000 tons of ore and 1,800 tons of refined copper, of a total value of \$2,125,000.

Some silver, nickel, and zinc are found in Norway. There were about 650 tons of nickel and 125 tons of copper mined at Christiansand during 1910. Silver is mined at Kongsberg. Aluminum is produced at Vigeland, the output in 1910 amounting to 860 tons. The production of ferrosilicon during the year amounted to 5,000 tons. Zinc is produced by the electric process from imported raw material. The output in 1910 was about 4,000 tons. The only zinc plant in Norway is at Sunkdeloken. The exports of calcium carbide in 1910 amounted to 50,000 tons. According to the United States Consular Report the aggregate capacities of the carbide plants are about 100,000 tons annually, but on account of low prices some of the plants have closed down.

Shaft Sinking by Poetsch Method

Determining Direction of Bore Holes. Formation of the Ice Wall and Its Resistance to Pressure

Special European Correspondence

The method of shaft sinking with the aid of the freezing process dates as far back as 1883, when an engineer named Poetsch sunk the first shaft of the brown coal seam at Schneidlingen with success. From that time until the present, although many improvements have been introduced into the process, little that can be called material has been altered. The principle is a simple one consisting in freezing the water that causes the instability in certain strata between the surface and the mineral that has to be extracted. In order to do this, the diameter of the shaft having been fixed, it has to be increased by from 10 to 15 feet, the increased circumference being used for letting down the bore holes for the freezing pipes. The number of such bore holes of course is given by the circumference of the shaft. They are placed at distances of about 3 feet from each other, and as a rule there will be from 25 to 35 bore holes for a shaft of from 15 to 20 feet in diameter for normal working.

To this number have to be added certain supplementary bore holes which become necessary because of the frequent cases of deviation from the vertical line of the original bore holes intended to accommodate the freezing pipes. Such deviation naturally would be influenced by the nature of the ground and intensified by the depth of the hole. The freezing pipes will be 5 inches in diameter, of fairly heavy metal of which the bottom end is fitted with a cap, they having previously been subjected to a pressure of from 350 to 600 pounds per square inch, according to the depth of the shaft. They are then by means of suitable fitting at the top end fixed to a collecting ring.

The "downlet" pipes consist of 1- to 2-inch strong wrought-iron pipe, and after they have been let down into the freezing pipes are fixed at the top to a distributing ring. The sections are jointed so as to allow for the tension and contraction of the metal due to the differences of temperature to which the metal is subjected, thus obviating leakages. The whole system for the circulation of the brine or freezing mixture is quite simple, any difficulty consisting entirely in getting the bore holes as near the vertical as possible.

Sinking bore holes, as is known, is an expensive process and the fewer supplementary ones that can be done with the better. One of the great difficulties in handling this question is to know what direction the bore hole has taken when it has left the vertical line and how far it has left the line. Many expedients have been resorted to to get acquainted with the situation under the surface, but the one which appears to have obtained most favor by experts in shaft sinking by refrigeration is that recently described in the patent system of Gelhardt and König. It had always been held that shafts of over 500 to 600 feet deep must necessarily show deviations in the bore holes, and at length the system referred to appears to make the man on the surface acquainted, to within very narrow limits, with: (a) The direction of the deflection; and (b) its extent.

In the pipe is hung a pendulum which can be driven by clockwork at fixed intervals in point of time, and this pendulum will periodically make a mark on a strip of paper as the same is at regular intervals brought past it. It is in reading these

marks, which are shown at distances of 5 to 7 yards, in the bore hole, relatively to a system of coordinates showing the degree of deviation of the bore hole, that the whole position in respect to any particular bore hole can be read above; that is, as to extent of deviation; but what is about as important is the direction, and to find this out electromagnets are used which also register the position by at intervals coming into contact with the wall of the pipe, these magnets being prevented by a special arrangement from revolving from the direction they possess at the beginning.

Such a system, however, it appears is not infallible; for it is admitted that there is a possible margin of error to be allowed for both as to deflection and direction, but it is sufficiently accurate to avoid a large proportion of the losses hitherto involved in sinking fresh bore holes, when it was not absolutely known how far the bore holes they were designed to supplement had deviated from the vertical line nor yet in what direction. It may be added here that the results obtained from each bore hole by the instruments referred to are carefully registered on a plan, and when the geology of the ground is known to the contractor, he will be able to sink his new bore holes as far as physical circumstances will allow at the right spots.

The question now simply amounts to the producing of refrigerated brine on the surface which has to circulate through the pipes and freeze the surrounding ground, including any watery strata, sufficiently to make it safe to sink through it as though through solid ground. The plant required for producing the refrigerated brine will of course depend on the diameter and depth of the shaft to be sunk. It consists usually of the compressors, the condensers, and the refrigerators. Nothing more need be said of this, because with little modification any refrigerating plant that will supply brine at a low temperature and deliver the same to the freezing pipes now supposed to be sunk to the required depth round about the ground that is to be excavated, will suit. Local conditions may decide the system to be used.

The difficulty hitherto has not consisted so much in making the bore holes and fitting the pipes as in dealing from time to time with accidents such as eruption of water when the shaft has been sunk a good way down, through some defect in what is termed the frost wall, possibly because of defective circulation of brine or perhaps, as has occurred, overcon-

fluence on the part of the contractor trusting to the strength of the frost wall and reducing the expense in supplying the necessary brine to maintain it intact. The brine or freezing liquid commonly used is chloride of magnesia, which is reduced to a temperature of from 15° C. to 20° C. below freezing and pumped into the distributing ring, whence it finds its way through the downlet pipes, returning through the bore pipes into which these latter have been let down, returning by way of the collecting ring once more to the refrigerators, where it is cooled afresh and continues, so to speak, its cycle.

The theory is perfectly simple. The brine on its return journey extracts the heat from the surrounding ground and forms theoretically round each pipe a cylinder of frozen material which, by the continuous process of refrigeration, gradually extends until it meets the frost ring or cylinder of its neighbor; and so ultimately a complete circular frost wall is established which, if sufficiently strong, enables the sinkers to do their work without fear of invasion of water from the surrounding ground. The danger from this moment is probably only from below. As can be imagined, at the bottom of the ring of pipes

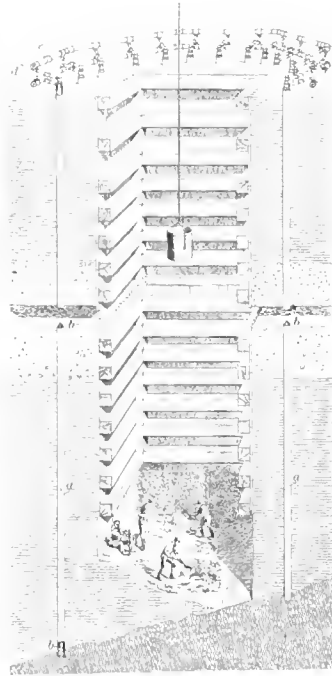

FIG. 1. SINKING IN FROZEN GROUND

ing takes place in the ground in such form as to produce something like the bottom of a bottle. That is to say, the frost extends outwards and downwards, but weakening towards the center. There is a kind of hollow, which, however, is immaterial; as the frost wall, if refrigeration be properly directed, will extend far enough below and across the diameter of the frost ring to prevent any accident taking place from below. The difference in temperature which is gradually reduced as between the returning brine and the surrounding wall becomes ultimately one of 2 to 3 degrees and the frost wall under circumstances such as just described may be considered as closed in between 2 and 4 months and sufficiently strong to stand the pressure of the ground during sinking. The margin of time named naturally varies according to the diameter and depth of the shaft; and further, it is a consideration of great technical interest, on the nature of the ground being pierced, that is to say, its greater or lesser heat conductivity.

Respecting the observations during the freezing period and its duration, the following should be observed: As soon as the frost wall begins to close, the water in the initial shaft which serves to accommodate the stand pipe and the distributing and collecting pipes, begins to remain stationary and then to slowly rise; whereas during the initial stages of the freezing the water level falls, or, supposing the initial shaft does not reach the ground water level a hole may be bored in the center for making observations. This is the best indicator of the closing of the frost wall, for the water inside the frost wall when it is closed cannot escape outwards and must rise as the space becomes less. This middle bore hole serves at the same time as compensator for any hydraulic expansion that may occur in the strata that are impermeable to water. Should the water level rise from 3 to 6 inches in 24 hours, which would indicate the closing of the frost wall, then in the case of an initial shaft which has been sunk sufficiently deep, water should be added; and if then, in spite of this additional pressure the column of water rises further, indicating the resistance of the frost wall, then, generally speaking, the sinking can be begun.

Experience in the freezing process has shown that the easiest and quickest strata to be frozen are water-saturated sands, also quicksands; whereas clayey sand or clay freezes relatively slower. The most unfavorable for the process is brown coal, which, as a bad heat conductor, naturally discourages the freezing process. This is not to say that brown coal mines are not suitable for the freezing process in sinking, for it has been shown that a large number of brown coal shafts have been successfully sunk. Respecting the resistance of the frost wall it may be said that quicksand offers the greatest resistance. A table has been published showing the relative resistance as follows: Water-saturated sand, 138 kilograms per square centimeter at a temperature of 15° C.; 200 kilograms per square centimeter at a temperature of 25° C.; sandy clay, 90 kilograms per square centimeter; fairly pure clay, 72 kilograms per square centimeter; pure ice, 18 kilograms per square centimeter, all these last three at 15° C. The resistance of the frost wall grows with increasing cold and it must be noted that when pure water is concerned or pure ice when frozen, the resistance is relatively very small; and it

is shown that ice only serves as a certain binder to fill up the space between the particles of sand. Whether thereby the friction resistance is increased and the resistance of the frost wall depends on the size or forms of the grains has not yet been established, but such may be presumed.

There appears to be no limit in respect to useful depth to which the freezing process may be applied for shaft sinking. A shaft 1,325 feet deep has been undertaken at Baesweiler, on the continent, whilst numerous cases can be cited of successful sinking down to as far as 1,082 feet, this last depth having required 286 days for boring, 104 days for freezing, and 379 days for sinking, including the tubbing. This shaft belongs to the Riedel Potash Works, of Hanover. The boring was done at the rate of 144 feet per day and the sinking, including tubbing, at 2.88 feet per day. The number of shafts tabulated from which the two indicated above are selected is 56, and they include coal, potash mines, etc., in Germany, France, and England. The refrigerating agent used for cooling the brine appears to have been mainly ammonia, though in many cases carbonic acid was used; and it has been pointed out with reference to the most important shafts, respecting the sinking of which data are given in the table named, the Solvay pit No. 1 was sunk in the astonishingly short period of 36 months, as against the contract period of 68 months. It is true that at

a depth of 787 feet of clayey sand a defect in the frost wall was revealed, but this was promptly and efficiently repaired. All the other strata were frozen faultlessly, and in the very lowest reaches of the shaft the frost wall was complete, compact, and free of faults; although it had to stand a very high pressure of more than 381 pounds per square inch, so that the frequently expressed view that ice, or rather a frost wall, under a pressure of from 295 to 370 pounds per square inch will give way is absolutely contradicted.

In the shafts of the Friedrich Heinrich coal mines the boring period and freezing period went through smoothly, and the sinking could be begun after 4½ months of freezing. The sinking ran normally down to 475 feet with a disturbance in the clay which interrupted the work at that depth; and it was found necessary to make a fresh series of bore holes to strengthen the frost wall on the side that gave way, whereupon the sinking was recommenced.

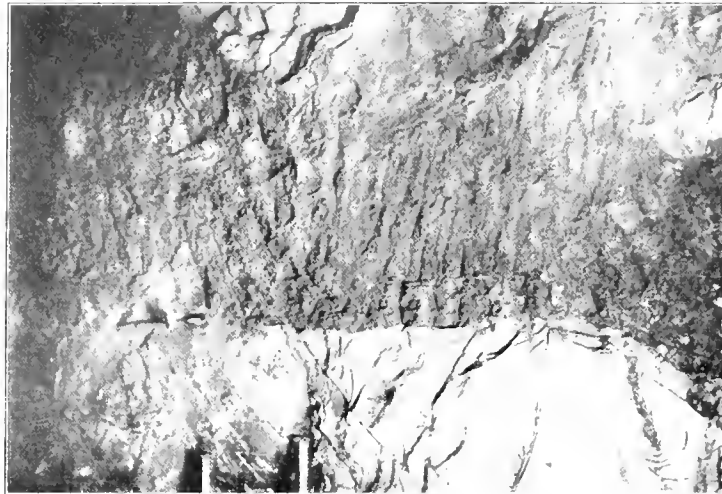

FIG. 2. FROZEN GROUND IN SHAFT

采 采

Enforced Development of Mining Claims

Most important, perhaps, in any amended mining law would be provision for enforced development of mining claims, a principle expressed, it is true in the present law but not effective in its workings. A requirement of actual use as a condition of occupancy of mineral land cannot be regarded as either novel or radical. As regards the large acreage of undeveloped land in many mining camps to which patent has already been issued, it is perhaps true that the situation is without relief, unless the Western Australia plan is adopted, whereby the Government steps in and permits mining under a lease, the proceeds of which are assessed, collected, and paid over to the owner. The principle involved seems to be that no property owner can rightfully oppose the development of the state.—Geo. Otis Smith.

The Voorspoed Diamond Mine

Geological Conditions Peculiar to this Mine. Various Minerals that Have Been Found

By H. S. Harger, F. G. S.*

The Voorspoed mine is situated some 5 miles northeast of the Lace diamond mine in South Africa. With the exception of the Premier, it is the only large payable diamond mine that has been discovered during the last 17 years.

The formation surrounding the pipe consists mainly of shales, but these are overlain on the northeastern edge of the mine by feldspathic sandstones. These form the wall of the mine for about one-third of its circumference, a basic amygdaloidal aphanite, or cryptocrystalline basic igneous rock, constituting the remainder.

The diamondiferous portion of Voorspoed pipe covers about 800 claims, but at one time, the writer (who was the discoverer) anticipated it would cover fully 1,500 claims, for the reason that the area within the shales equaled that number. It was known that a considerable area on the south and east within the rim rock consisted of aphanite, but as a huge mass nearly 50 feet in thickness also lay in the middle of the mine, and proved to be merely a "floating" mass, it was hoped the remainder would likewise be "float" rock, and give place to kimberlite (or altered peridotite known as "blue ground") underneath, as happened in nearly all of the largest mines, to wit, Dutoitspan, Bultfontein, Jagersfontein, and Wesselton. Such, however, was not the case. On the southern portion, which consists entirely of aphanite with little patches and veinlets of kimberlite in it, several bore holes were put down, but none of them passed through the aphanite, the greatest depth reached being 600 feet. The eastern portion was similar, the aphanite having apparently been much fractured, and containing patches of kimberlite in several places, whilst in another the aphanite and kimberlite were indiscriminately mixed up.

On the southern portion a fissure containing highly micaceous kimberlite (free from pebbles and boulders) was met with in two places, striking roughly east-west. The ground in these cases was typical fissure ground. In close proximity, however, was a patch several claims in extent of kimberlite, containing boulders and pebbles, and in all respects resembling the pipe kimberlite.

In addition to the masses of aphanite referred to, which occupy an area of nearly 700 claims, the mine ground, wherever met with, contains a very noticeable amount of the aphanite throughout, varying in size from microscopic dust to huge masses. In almost any hand specimen the presence of the aphanite can be detected, either with the naked eye or a lens.

After a careful study the conclusion of the writer is that a volcanic diamond pipe occurred within the neck of a preexisting volcano, the stump of which alone remains owing to denudation. The shape of the entire occurrence within the shales, as seen today, is almost truly oval, and occupies about 1 500 claims. The intrusions of kimberlite appear to have blown out more than half of the older volcanic filling, but failed to displace the remainder. The explosive forces, however, shattered the remaining aphanite in all directions, filling many cracks with kimberlite and in several places forcing out masses of rock several claims in extent, and replacing it with a true kimberlite of serpentine breccia. The tilting of the shales at the contact all round the aphanite, proves the rock to be intrusive, although owing to weathering no evidence of metamorphism was observable in the shales. The presence of shale and sandstone forming a complete girdle around the aphanite and kimberlite shows that the occurrence is not a big dike. It forms today a roughly crescent-shaped mass around three sides

of the mine between the diamondiferous kimberlite and the shales, and is evidently a solid vertical column of aphanite, representing portions of an extinct volcanic neck, or, in any case, a pipe-like intrusion of a related kind.

The rock is a grayish-green basic amygdaloidal aphanite. A few blocks found loose in the kimberlite are highly vesicular, and contain almost 50 per cent. of white heulandite, a calcium aluminum silicate, and calcite—the former predominating, but the solid column of aphanite, tested to a depth of 600 feet, is but slightly vesicular, and contains much smaller amygdules, whilst the zeolites are replaced by calcite. Some of the cavities have been only partly filled, and contain much dull green chloritic matter, while an occasional speck of copper was observed. Under the microscope a thin section shows the feldspars, which are lath shaped, the interstices between them being partly filled with chloritic alteration products, and also with a greenish aggregate, containing acicular feldspar micro-lites. Some serpentine pseudomorphs, shaped like basal olivine sections, and the usual iron oxide accessories were plentiful.

Like almost every similar occurrence, the Voorspoed pipe is on a line of weakness occupied by a fissure containing kimber-

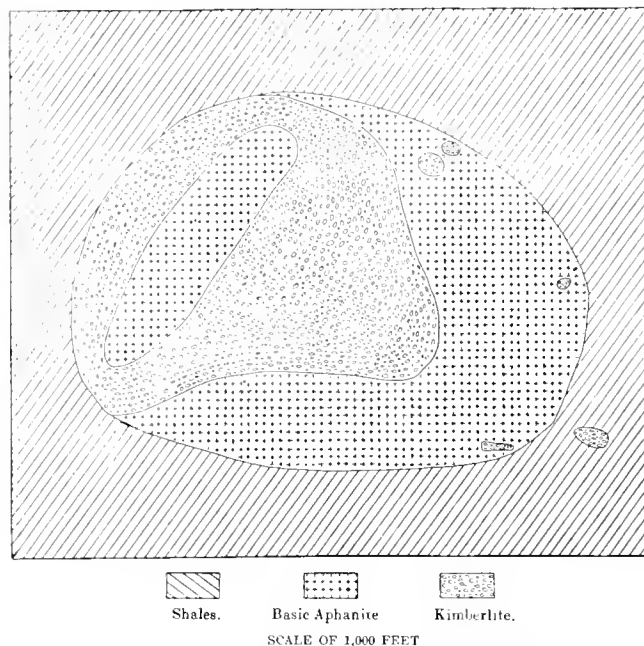

HORIZONTAL SECTION OF PIPE AT VOORSPOED MINE

lite, and this has been traced and opened up for 4 miles. This fissure was formed before the diamond pipe, as it is found dissecting the country rock right up to the wall of the mine, but not within it. The fissure, however, like the pipe, is evidently younger than the aphanite, as a fissure with similar strike (and probably an offshoot of it) can be seen traversing the aphanite, which forms the southern wall of the mine. The fissure ground is of the micaceous variety, very fine in texture, and containing no minerals that can be discerned with the eye, except a few garnets. In places, however, it contains roundish pebbles and boulders, usually of quartzite. The latter appears to have resulted from the metamorphism of sandstone and alteration of feldspars, probably due to the heat of the magma in which they had been caught during its passage upwards. Similar heat phenomena occur in other dikes known to the writer, but have not been observed in any of the large pipes.

The ground in the pipe differs entirely from that in the fissure. In the central portion of the mine the ground is bright yellow in color, rough and pebbly, and rather full of very small mica. It contains about 50 per cent. of round and oval-shaped pebbles, and small boulders, the latter consisting of aphanite,

*From J. C. Johnson's "Geological and Archeological Notes on Orangia."

granite, gneiss, quartzite, Dwyka conglomerate, etc. Ultrabasic rocks are either entirely absent or extremely rare—not having been met with by the writer.

The most interesting boulders found, however, consist of a few large garnet rock, quite different to anything the writer has met with in other diamond mines; this occurs both as a coarse and medium crystalline granular rock, in which usually from one third to half of the rock consists of much cracked, pale, clouded, mauve colored garnets attaining at times a diameter of nearly $\frac{1}{2}$ of an inch, and flakes of graphite. A thin section made from the same rock, but of finer texture than the above, was examined by Mr. Weber, of Johannesburg, who found it to be made up principally of white feldspar, garnet, quartz, and monoclinic pyroxene—the latter quite subordinate to the other minerals. All the above minerals contain systems of acicular needles, having very strong double refraction, with extinction angles varying from 0 degree to 4 degrees, and colors varying from dark brown to brownish green.

The only other boulders found at Voorspoed and requiring special notice are roundish, highly micaceous lumps of kimberlite of the fissure variety, containing an occasional garnet. These boulders are not only round and oval in shape, but have usually very smooth and unctuous exteriors. Owing to their exact resemblance to the ground found in the fissure on which the mine occurs, it seems quite probable that they represent masses or fragments of the fissure rock which were broken up, rounded, and distributed throughout the mine when the pipe burst through. It is quite reasonable to expect the fissure kimberlite to be represented in the pipe breccia as well as the other wall rocks found therein, but some local segregationists prefer to attribute their origin to magmatic segregation. The true origin of these boulders, however, like the eclogites and altered rocks, has yet to be solved.

The minerals found in the Voorspoed kimberlite are not very numerous or plentiful nor do they form a "pretty deposit" such as one sees at Jagersfontein, Koffyfontein, Bultfontein, and many other mines. The principal mineral is garnet, most commonly a clouded red in color, and much cracked. Some transparent pink to red pyropes occur, and also pale yellow to orange-red hessonite. Stones of the latter quality are much scarcer than the diamond both in this and every other known mine. The garnets seldom exceed $\frac{1}{2}$ inch in diameter. Minute octahedral crystals of picotite (chrome spinel) are plentiful. A little ilmenite occurs, and is often to be seen in dull gray very smooth grains, as if water worn. In addition to the foregoing, of which the concentrates mainly consist, a little diopside, pyrite (in both cubical and "buck-shot" forms), calcite, mica, barite, and an occasional piece of galena are found. Enstatite, which is present in most of the mines and quite plentiful in some, was not observed, but might make its appearance at lower levels. The present working faces in the mines are all above the 100-foot level.

The diamonds are of a small average size, parcels usually containing a high percentage of specimens ranging from $\frac{1}{2}$ to 3 carats, but stones of from 30 to 40 carats in weight are occasionally found. Although "bright stuff" of very good quality is constantly found, the grade in large parcels is not high, like Jagersfontein, Koffyfontein, and the Roberts-Victor mines. All shades of "white" are found, and occasionally good "blue whites." When cut, the white stones are very brilliant. Pale "yellows" and "bye-waters" are plentiful, but "deep yellows" of the "fancy" descriptions rare. Pale "rose pink" occur, but generally weigh a quarter of a carat or under, as at Bultfontein, although one of 5 carats was found, and retained its color after cutting. The crystallization of the gems is mainly of the round and elongated rhombic dodecahedron shapes, these being often very bright and smooth, and having curved faces. Perfect octahedra are seldom seen, though the Lace mine, a few miles away, contains quite a high percentage of octahedral forms. The cube, so common in South America

and rare in South Africa, has also been found in Voorspoed mine, the writer having a small one weighing under $\frac{1}{2}$ of a carat. A careful examination of one parcel showed a high percentage of diamonds which had been broken. Some of these might have been fractured in the mining and washing operations, but broken stones were found in the earlier stages of exploitation, before either dynamite or machinery was in use.

A most interesting feature of the mine in relation to its genesis is the distinctly variable nature of the ground in different portions of the mine. About 60 claims in the center of the pipe consist of bright yellow ground, soft and unctuous to the touch. It is full of small mica, and contains about 50 per cent. of roundish pebbles and boulders up to 1 foot in diameter. The boulders have already been referred to. This ground breaks up freely in any direction into rough and roundish lumps. The remainder of the mine produces quite a different class of ground, grayish in color, harsh to the touch, comparatively free from boulders, and with much fewer pebbles. It is distinctly laminated and when broken up for hand specimens gives flattish lumps. The difference between the two classes of ground is so marked that one might easily conceive them to belong to independent mines.

The output of diamonds from the Voorspoed mine has been as follows:

	Loads	Carats
1906, July to December	40,096	9,244
1907, January to July	70,311	1,839
1907, July to December	123,041	26,813
1908, January to June	141,346	28,719
	374,794	78,615

采 采

Another "Chicken Bill" Yarn

Western mining people have either known William Loveland personally, or have read or heard about his notorious adventures. Every once in a while a new story bobs up about this character of Colorado's early mining days.

Here is one that was very recently related, which shows the clever trickery practiced by this plain prospector who twice became a very public figure; for this is the same man who salted and sold the Chrysolite claim, on Fryer Hill, Leadville, to ex-Senator H. A. W. Tabor, and who subsequently perpetrated the Mount Pisgah placer fraud just west of the present Cripple Creek district.

It seems that Bill manufactured some very clever imitations of gold nuggets by dropping molten brass into water. On one of his periodic visits to Denver he dropped into a Hebrew clothing store to make some purchases, explaining frankly to the proprietor that he was without cash, but at the same time permitting a casual glance at the contents of his sack of bogus gold nuggets. This was sufficient, and Bill was accorded permission to buy the entire stock if he wished; a permission of which he availed himself freely. After settling for his purchases with the nuggets he was dismissed with many flourishes of the hands and with a cordial invitation to call again.

The error was soon discovered and in a few hours detectives had Bill in charge. At his hearing the next morning Bill calmly admitted the manufacture of the nuggets and his methods of disposing of them, but despite the obvious deceit practiced, the court found it convenient or expedient to discharge him, for he testified that he distinctly said to the merchant, who, in gloating over the nuggets, called them "beautiful gold."

"O, no, those are only nuggets. They are not gold."

As the duped one admitted this statement, the judge ruled that Chicken Bill could not be held and the Hebrew was taxed with the costs.

In rendering this decision the court appears to have been led thereto by the same process of reasoning followed by the Supreme Court of one of the eastern states in ruling essentially, that where two rascals try to dupe one another, neither can recover in event of his being fleeced.

Bill's salting of Senator Tabor made quite a stir at the time by reason of its peculiar outcome. In the early Leadville days Tabor was teaming to the mines from Denver by way of Platte cañon. Daniels & Fisher, the well-known Denver outfitters of that day, asked Tabor to buy them a good mine in the new camp and not to be too particular as to the price paid.

Tabor appears to have talked freely of his commission. In any case Bill heard of it and salted a claim which he sold Tabor for \$50,000 in cash; a large sum for those early days. After but a slight investigation the salting was proved and Daniels & Fisher declined to take the claim, leaving it on Tabor's hands. He, of course, could not stand the loss, and went to work developing the property in the hope, probably, that it might not be as bad as it looked. Be that as it may, it was not long before Tabor developed the well-known Chrysolite mine, on Fryer Hill, which laid the foundation of his subsequent fortune.

采 采

Blast-Furnace Smelting With Oil

For the practical demonstration of blast-furnace smelting with oil, the Colorado Iron Works Co., of Denver, has built a smelting furnace, of from 80 to 120 tons daily capacity, at their works. This furnace, which is shown in Fig. 1, is 4 feet in diameter at the tuyeres and 5 feet diameter at the top of bosh.

It is equipped with many refinements not usual in smelting furnaces generally; further, it requires but about one-eighth the water for cooling jackets usually used in furnaces of the same size, by reason of its utilizing the latent heat incident to vaporizing water into steam and dissipating such heat to the atmosphere instead of overflowing the water from the jackets in the common way, and thus saves seven-eighths of the amount of water commonly used and avoids also the nuisance of water flowing in open troughs around the furnace.

There are gas taps every 3 feet up and down, where the furnace gases are taken for analysis.

Temperature is also taken, as desirable, at the gas taps, with a Le Chatelier thermoelectric pyrometer.

The operation of this furnace requires fuel oil and the claim is made that the system advocated is the only logical method of smelting pyrite, pyrrhotite and associated sulphides, conserving at the same time the calorific value of these minerals.

Heat is delivered into the blast furnace near the bottom of the ore column in amount and intensity precisely as required and under complete and instantaneous control. If smelting gold and silver ores in which there is only enough iron-copper sulphides to form the matte, then no fresh air is blown in and all sulphides are melted to matte, which carries the gold and silver of the ore.

On the contrary, if the ore carries an excess of sulphides, then air is blown into the furnace in amount accurately calculated and adjusted to oxidize the excess sulphur to the predetermined proportion required for the matte, and the ultimate calorific value of the iron and sulphur so oxidized is realized in the smelting operation. The air blast entering the furnace very close to the heat ducts, strikes the ore at smelting temperature, or at any predetermined temperature, and enables the pyritic smelting of ores high in sulphides to become a simple, and a positive process, defined in all its details. All the elements of guesswork and uncertainty incident to present methods are eliminated, with the abandonment of carbonaceous fuel from the ore charge.

Ore and flux are charged into the top of the furnace in pro-

portions to form a fluid slag. The air blast oxidizes the sulphides, producing heat, but if not enough heat is generated in that manner to smelt the charge, it is supplemented with whatever heat is necessary, by burning petroleum, and introducing it at the bottom of the furnace. This heat enters so near to the tuyeres that any accretions beginning to gather there are readily assimilated with the surrounding silica and melted away by applying the heat necessary, and such heat is ever attainable by this hydrocarbon method.

The comparative costs of smelting with oil and coke, based on conditions that prevail in Arizona, are calculated as follows:

Assume that coke with 14 per cent. ash costs \$12 per ton; then since carbon yields 14,500 British thermal units per pound, there will be $100 - .14 = .86 \times 14,500 = 12,470$, or for easy calculation, 12,500 British thermal units per pound of coke.

Assume, for comparison, that one hundred million (100,000,000) British thermal units be produced, then this divided by 12,500 gives 8,000 pounds, or 4 tons of coke as required, which will cost \$48. To this 10 per cent. is to be added for unloading, waste, and charging into the blast furnace, or a total of \$52.80.

Assume oil at \$1.25 per barrel, specific gravity .925 = 7.5 pounds per gallon, 42 gallons = 315 pounds per barrel = .4 of a

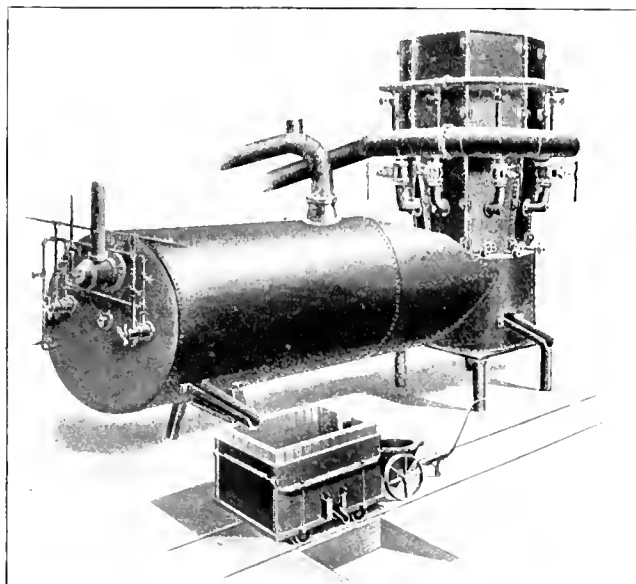

OIL BLAST FURNACE

cent per pound. In a properly equipped plant there is no cost for handling, as oil is piped from the tank car to the storage tank, and again from the storage tank to the combustion chamber of the blast furnace.

Assume the calorific value of oil at 19,000 British thermal units per pound, which is below the average number of heat units, then to produce the 100,000,000 British thermal units will require 5,263 pounds of oil, which, at .4 of a cent per pound amounts to \$21.05.

Thus, on the basis of comparison above assumed, \$21.05 worth of fuel oil will furnish the amount of heat to the blast furnace that costs \$52.80 with coke fuel.

To the coke should be added the cost of the heat involved in fluxing the ash, this is 14 per cent. of 8,000 = 1,120 pounds ash, which, if the most favorable allowance possible is made, that is assuming the coke is so near self-fluxing as to require but 20 per cent. of its weight in bases for flux, then 1,120 pounds ash + 20 per cent. iron and lime = 1,344 pounds of barren material that must be smelted with every 4 tons of coke. Oil has no burden of this kind, which, of course, is in its favor.

The New Electric Hoists at Ray, Ariz.

Conditions at Ray, Large Hoists Operated by Electric Motor by Means of Rope Drive

The camp of the Ray Consolidated Copper Co. is at Ray, 6 miles north of Kelvin, Ariz., the two places being connected by a railway following up the gorge of Mineral Creek. At Ray the narrow stream bed widens out into a flat, shown in Fig. 1, upon which the camp is built, but above the camp it again cuts

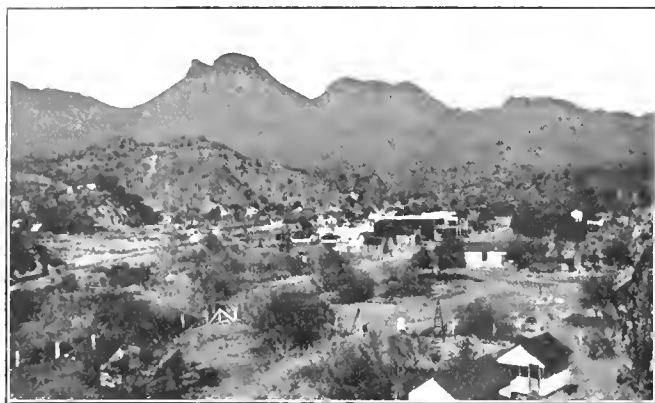

FIG. 1. CAMP OF RAY, ARIZONA

a gorge through quartzites overlying the Pinal schists, while above the quartzites appear Carboniferous limestone.

On Teapot Mountain, shown on the skyline of Fig. 1, are found beds of tuffs which in turn are capped here and there by dacite. This hard rock is responsible for the striking escarpments which cap the slopes of the peaks. Evidently extensive erosion has removed the sedimentaries overlying the Pinal schists in the extensive area to the northwest and west of Ray. To the east of Mineral Creek the Pinal schists are overlain by quartzite, except for several small patches close to the stream where the quartzite has been eroded. The mineralized area is included in the great belt of Pinal schists exposed where the overlying strata have been eroded back to slopes of the surrounding mountains.

In Fig. 2 Mineral Creek is shown in the foreground with the machine shops to the left and the ore bins to the right. According to Philip Wiseman, in 1909 there were 30,000,000 tons of ore, 15,000,000 tons of which carried 2.4 per cent. copper. This ore differs from the porphyry ore of the Utah Copper Co., at Bingham, in that it is found in Pinal schists to a large extent. As is known, in order to work low-grade copper deposits satisfactorily a large tonnage must be mined and treated daily. Recently a new electric hoist has been installed by the Ray Consolidated Copper Co. at their No. 1 shaft, shown in Fig. 3, which raises heavy loads in order to keep up the large production required from this shaft. The hoist has now been in operation about 6 months and a duplicate hoist is being installed at No. 2 shaft about 1 mile distant. The electric power for operating this hoist, as well as the compressor and other machinery about the mines, is generated at a large power plant at Hayden, Ariz., 19 miles from the mines, at which point the large concentrator is located, and where a smelter for this company is being erected. The power is generated by four-cylinder triple-expansion condensing engines direct-connected to alternating-current generators, and is transmitted to the mine at 40,000 volts. The hoist motors and generators were furnished by the Allis-Chalmers Co.

The hoist, it is believed, differs from any previously designed, from the fact that it is rope driven and is connected by two sets of gears.

The hoist was designed by the Wellman Seaver-Morgan of Cleveland, Ohio, to lift a load of ore weighing 12½ tons,

together with a skip weighing 8 tons, from a depth of 500 feet, at a speed of 300 feet per minute. The hoist operates with balanced skips, one of the drums being keyed fast to the shaft while the other drum is driven by a powerful modified Lane band friction clutch for adjustment to the different levels, as desired. The hoist is driven with an alternating motor, 440-volt, three-phase, 60-cycle, with a full load speed of 430 revolutions per minute and 300 horsepower continuous rating. On the motor shaft is fitted a 44-inch diameter rope wheel having grooves for thirty-two 1-inch ropes that drive the 13-foot diameter rope wheel on the pinion shaft of the hoist shown in Fig. 4.

In designing this plant, the underlying object, which was kept ever in mind, referred to making arrangements of such a nature that the motor should operate continuously in one direction, while the drums could be started, stopped, or reversed independently of the movement. As is well known, the principal electric loss in hoists operated by alternating-current motors is occasioned by the starting, and if the motor is large it becomes serious. It is desirable, therefore, not to be obliged to start the motor at each trip, since, when the motor is running idly, the current required by it is so limited that the peak losses are materially reduced. With this hoist the load is gradually accelerated by applying powerful band friction clutches.

For the benefit of those unfamiliar with band friction clutches, the following description is given:

Fig. 5 shows a band friction clutch that is attached to and revolves with the shaft *a*. The winding drum runs loosely on the same shaft and has a driving-band ring or seat *b* on one end; when the ring *c* of the clutch is tightened by means of the mechanism shown, the clutch and driving band become practically one piece and the drum revolves with the clutch. The clutch is constructed as follows: The driving disk *d* keyed to the driving shaft *a* is connected to one end of the ring *c* by a fixed arm *e*, which is bolted firmly to the disk *d* and revolves with it; a movable arm *f* that connects with the other end of the band *c* turns on the pin *g*. When the band *c* is loose, it can revolve about the seat *b* without touching it, but the band can be tightened and made to clamp *b* either when revolving or standing still, as follows: The sliding sleeve *h* may be caused to slide about 6 inches along the hub of the disk *d* by levers (not shown) and take hold of trunnions *i* on a ring on the sliding

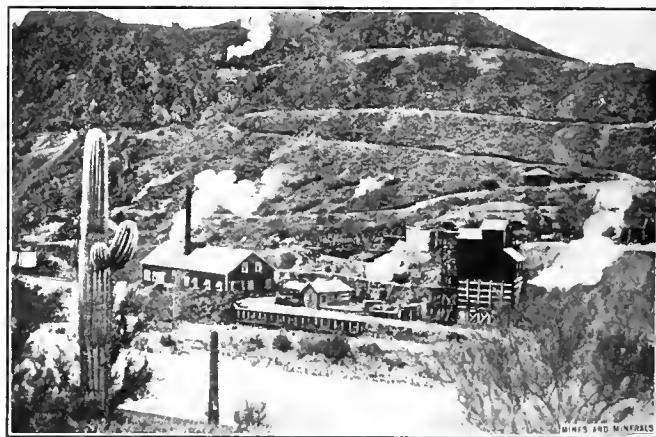

FIG. 2. RAY CONSOLIDATED MINES

Mineral Creek in foreground; Machine Shops at left; Office, center; Bins at right; Tunnel back of Bins

sleeve; this sleeve is connected to the movable arm *f* by a link *j*, and when the sleeve is on the end of the hub the link stands at an angle of about 60 degrees with the shaft; by sliding the sleeve toward the disk *d*, the link is made to move the arm *f* about 1½ inches at its outer end and to thus tighten the driving band *c*, so that it grips the ring *b*. The adjusting nuts *k* take up the wear of the wooden blocks with which the ring *c* is lined. Band lifters *l* hold the band clear of the ring when it is loose. The

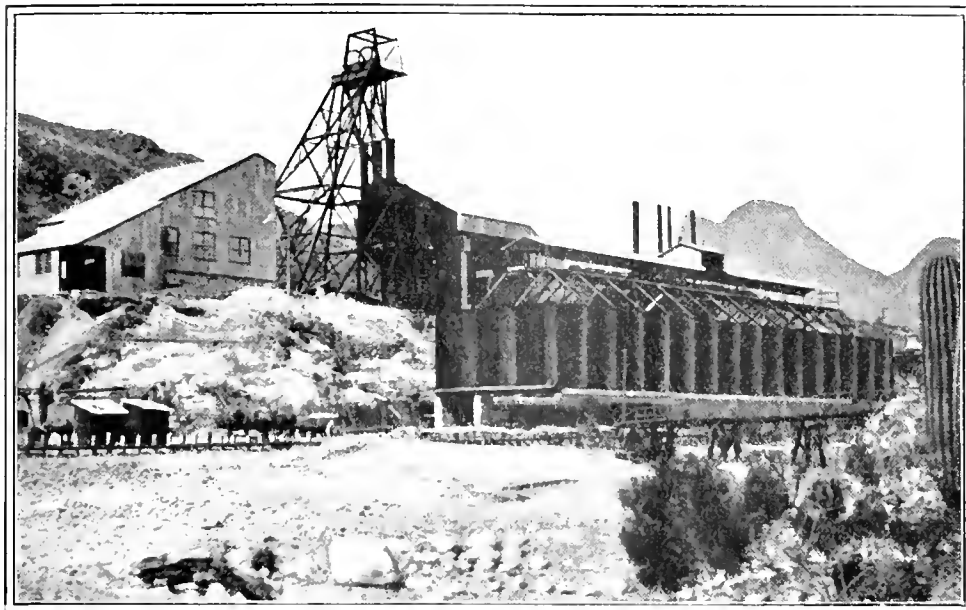

FIG. 3. RAY NO. 1 MINE SHAFT.

clutch shown is built to run in the direction indicated by the arrow, but such clutches may be built to run in either direction; they should always be run in the direction for which they are designed, so that the load may always come on the fixed arm. If the band be tightened slowly, there will be no sudden start or jerk on the rope, as the slip of the band will prevent the entire force of the grip taking effect at once, and after the drum reaches full speed, there is little or no slipping of the driving band. It is best to keep the band only just tight enough to do the work, for should the car get off the track, or be overwound, or should a cage stick in the shaft for any reason, the band will slip and thus become a safety appliance, and not strain or break the rope, shaft timbering, or machinery, as would be the case if a positive clutch were used.

The only available illustration of the Ray mine No. 1 shaft hoist is that of Fig. 4, which was kindly furnished by the Welman-Seaver-Morgan Co. From the illustration a general idea of the hoist is obtained, consequently only details which enter into its construction and emphasize its good and bad points are presented to the reader. The points of particular interest to the mining engineer are: the 13-foot diameter rope wheel driving the beveled pinion, the beveled gears that drive the pinion on the intermediate shaft, the brakes, and their means of application. The train of movements receives its power from the motor rope-drive, as described, but the beveled gears turn in opposite directions and so make it possible to continue a hoisting and reversing system.

Both bevel gears are loose on the intermediate shaft, but are fitted as shown with the friction rings and the band-friction clutches already described, which, in this case, are keyed to the shaft. To operate the clutches there are a series of levers connected with weights, but to release the clutches the vertical cylinders shown in the illustration are required.

The cylinder pistons are controlled in their movement by a cataract

cylinder filled with oil, the power for operating the cataract being compressed air taken from the air mains supplying the mines, although there is an auxiliary motor-driven air compressor in the engine house, which automatically cuts in and provides air for operating the hoist if the mine air pressure is shut off or goes below a certain predetermined pressure. Both of the clutch-operating cylinders are manipulated by a single lever from the engineer's platform and are so arranged that either clutch may be thrown in or out of engagement, but both clutches can never be in at the same time, and one clutch must be wholly thrown out before the other can be thrown in.

The intermediate shaft that carries the beveled gears also carries the pinion which drives the 16-foot gear-wheel on the drum

shaft. The drums are 12 feet in diameter and grooved for 1½-inch hoisting rope about 600 feet in length. An examination of Fig. 4 will show that one drum is fixed to the shaft while the other is loose and fitted with a powerful modified Lane band friction clutch, such as described and illustrated by Fig. 5. This clutch has a 12-foot driving ring constructed for a possible working load of 50,000 pounds. The clutch disk is of cast steel; the fixed and movable arms which engage the driving band are of annealed steel; while the friction band is of steel lined with basswood blocks. Arrangements are provided for adjusting the wear of the band, as well as lifters for equalizing the distance of the band from the clutch ring when the clutch is released. Each drum is provided with a powerful post brake, with steel posts fitted with basswood friction blocks 14 inches wide. For the benefit of those who are not familiar with the construction of the post brake a short description is furnished. The post brake, as shown in Fig. 6, has two block brakes *a a'*, which are applied to the drum at places diametrically

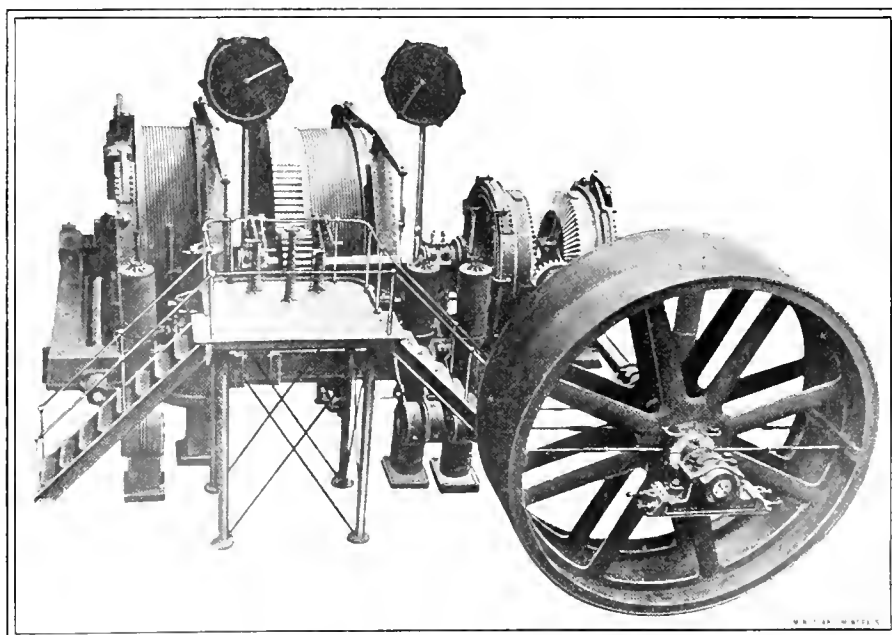

FIG. 4. ELECTRIC ROPE-DRIVE HOIST.

opposite directions, relieving the pressure on the drum-shaft journals and providing equal clearance at the top and bottom of the drum. The drum is movable at the top and bottom. The tension rod *b*, and levers *c*, *d*, and *e*. The drum is pivoted at *f* and transmits motion through levers *g*, *h*, and *i* to the fulcrums *j*. The brake post *a* is supported by the lever *k*, which, pivoted at *l*, swing backward and

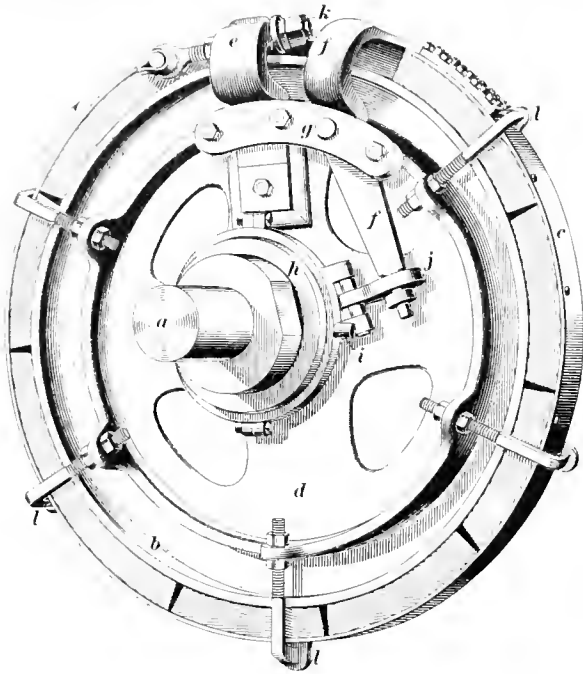

FIG. 5. BAND FRICTION CLUTCH

forwards in parallel. To adjust the motion at the bottom of the post so as to give equal clearance at the top and bottom, the setscrew *o* is provided. In the illustration the upright *m* for the post brake *a'* is pivoted at *n*. The brakes, as well as the drum clutch on the Ray hoist are operated by means of a combined air and cataract cylinder fitted with floating valve gear under control of a hand lever on the operator's platform. The brakes, which are set by weights, are released by the air cylinders.

The skips used at the Ray shaft are not provided with safety dogs and appliances, on account of the extreme weight and bulkiness of such equipment for a load of this magnitude, but instead a device is provided to prevent the skips being carried into the sheaves through any neglect of the operator.

This overwinding device consists of two limit switches, one for each skip, so placed that when the skip is carried beyond the highest point for dumping, it will come in contact with an extended lever, which, moving through an arc of 35 degrees, disengages the contacts. The limit switches are connected by wires to solenoids operating quick-opening valves in the supply pipes to the air cylinders, so that if the skip passes a given point in the shaft, the solenoids come into action and at once release the pressure from the operating cylinders, allowing the weights to apply both of the powerful brakes and throw out the clutches, bringing the hoist at once to a stop without the necessity of stopping the motor.

The hoist is designed with a high factor of safety to guard against any possibility of delay from breakage or derangement.

The ore is carried underground in 5-ton steel cars running in trains propelled by electric locomotives and is dumped into a 300-ton bin on each of the two main working levels. This is accomplished with revolving cage dumps, holding three mine cars at a time, which are upset by means of an electric motor. The ore is discharged into the bin beneath, from which it is drawn to a measuring hopper holding a skip load. When a skip is to be loaded,

it is spotted beneath the spout of the hoppers at any desired station and the hopper gate opened.

The ore skips are constructed of $\frac{1}{2}$ -inch steel plate, 4 ft. 10 in. \times 5 ft. 2 in. \times 10 ft. in depth, while the total height from the center of bottom swing bearing to the top of the rope socket is 18 feet. The cast-steel bottom swing bearings and saddles have each a bearing area on the bottom of the skip of $15\frac{1}{2}$ in. \times 45 in. The swing and saddle shafts are each $5\frac{1}{2}$ -inch diameter, collared and placed on 22-inch centers. The dumping rollers are of cast steel, bronze bushed with cast-steel trunnions $5\frac{1}{2}$ inches in diameter. The crosshead frames are $1\frac{1}{4}$ inches in thickness by 20 inches deep and are provided with special cone roller bearings to take the lower member of the cable socket. This construction permits the cable to turn or twist freely. The forged steel skip frames are $1\frac{1}{4}$ in. \times 12 in. in cross-section. The inside front and back of the main skip body is protected by $2\frac{1}{2}$ " \times 1" bars extending from the mouth of the skip to a distance of 3 feet 6 inches from the bottom. These bars are riveted to auxiliary plates 1.4 inches thick, which are bolted to the main body by means of special $\frac{3}{8}$ -inch bolts. This permits the easy removal of the bars for repairs or renewal.

No supplies, waste rock, or men are carried in the main hoisting shafts Nos. 1 and 2, but a smaller electric hoist is used in an auxiliary inclined shaft at each plant for handling waste rock and supplies, while the men go into and out of the workings by means of an easy stairway in these inclined shafts.

來 來

Barytes an Important Mineral

Barytes, or barium sulphate, is a heavy crystalline mineral, white when pure, which is very little affected by acids, alkalis, or corrosive gases. In 1910, according to a Report of the United States Geological Survey, the United States produced 42,975 short tons, valued at \$121,746, a considerable decrease as compared with the figures for 1909. Barytes is an interesting and useful product. By far the greater part of the mineral produced is consumed in the manufacture of mixed paints. It is not satisfactory as a pigment if used alone in oil, for its crystalline nature renders it too transparent to give good hiding power, and to be of any advantage it must be used in only moderate percentages in mixed paints, which consist principally of the lead and zinc-white pigments. Its use as an adulterant in white lead or in any other pigment or commodity is not legitimate and should be discouraged by the producers. There are sufficient legitimate uses for this valuable mineral to create a healthy market for it if properly handled. Barytes is used also in the manufacture of lithopone, a very white pigment that is suited most particularly to interior use and is employed in enamels and wall finishes. Barium salts are reported to be used in brickmaking in order to overcome the efflorescence of bricks. Other uses for barytes are in the manufacture of rubber, wallpaper, asbestos cement, poker chips, and in tanning leather.

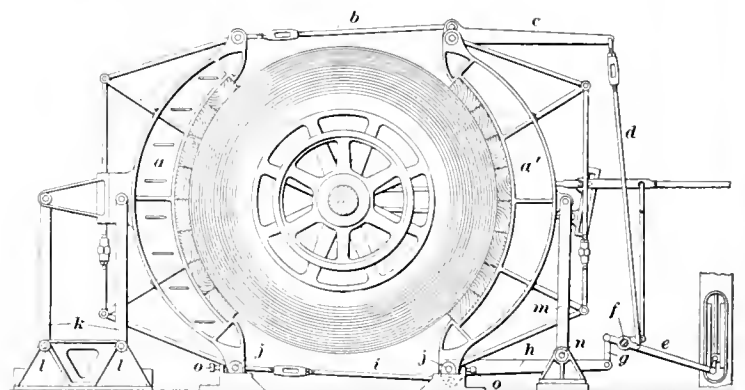

FIG. 6. POST BRAKE

Fires in Metal Mines

Instances Showing the Dangers and Difficulties of Dealing With Metal Mine Fires

Herbert Wilson, Chief Engineer of the Bureau of Mines, in a lecture before the National Fire Protection Association in May, 1911, says:

"Fires in mines are of far greater menace to life and property than is generally appreciated." This statement, while correct, might have been emphasized by saying that more of the mine disasters in which there was great loss of life were due to fires than to explosions. With the possible exception of Le Neve Foster, writers on metal mining topics have neglected this important subject, probably owing to the difficulty in procuring authentic records of metal-mine fires. The writer having had the same difficulty, this article is necessarily incomplete, but surely a subject so important is worthy of more attention than it has been given if the lives of metal miners are to be conserved. So much attention has been given to coal-mine explosions and fires that the metal mine fires have been practically overlooked; nevertheless, it may be of interest to know that in some metal mines as much care is taken to avoid mine fires as is taken in coal mines to avoid explosions.

In 1803 a fire started in the timbering of the quicksilver mine of Idria, Austria, and getting beyond control, necessitated the mine being filled with water. This is the first record the writer has of a mine fire, and it is taken from Prof. S. B. Christy's translation of Von Lipold, on quicksilver mines in Austria. To remove the water from this mine after the fire was out required 3 years. In 1846 another fire killed several men in the same mine and involved another flooding of the mine.

E. Lord, in Monograph 4, United States Geological Survey, 1883, under the heading "Comstock Mines and Miners," says: "Fires happened several times in the timbering of the Comstock mines previous to 1869." In that year, however, a fire occurred in the 800-foot level of the Yellow Jacket mine that caused the death of 34 miners. After 2 days, when all hope of rescuing the imprisoned men was abandoned, steam was forced into the mines for 5 days. This fire was not completely subdued for 6 months, as smoldering timbers were found from time to time during that period. It was deduced from this experience that steam was not effectual in extinguishing a mine fire, although it was useful as a temporary expedient for purifying the atmosphere of a mine and checking the flames so that it was possible for men to put in dams and cut off the supply of air to the fire. Mr. Lord further states that "in a period of 17 years 49 persons were killed by fires which occurred on the Comstock Lode." Mr. Wilson in his lecture stated that "in the Comstock Lode thousands of feet of tunnels, which had been opened and timbered at great expense, are being burned out, causing falling of the roof and dislocation of the metal-bearing vein, thus rendering future recovery of the ore difficult, if not impossible."

Le Neve Foster, in his work on "Ore and Stone Mining," states that "in 1888 some of the timbers in the De Beers diamond mines, South Africa, took fire. Flames spread rapidly and soon the mines filled with smoke to such an extent that 24 white and 200 colored miners lost their lives."

In 1888 a fire in one of the shafts of the Calumet & Hecla Copper Co., at Calumet, Mich., caused the loss of eight lives in addition to a considerable loss of property.

In the St. Lawrence mine, at Butte, Mont., a fire has been burning in an extensive area about the 1,100-foot level since 1889. The fire has been fought constantly, but cannot be extinguished, although it is possible to control its progress by bulkheads to a considerable extent. A complete fire-fighting brigade is kept working 8-hour shifts. Both the ore and the timber are burning and sometimes the fumes from this fire give

trouble in the adjoining mines, which are connected with the St. Lawrence. It is considered probable that the fire has crept from the St. Lawrence into the upper levels of the Anaconda mine. About 18 years ago a fire hood was developed for use when building bulkheads, air-tight cement walls, etc., that are necessary to confine the sulphur gases which occasionally find access into the mine from the burning sulphide ore in the middle levels of this deep mine. The hood, which is described in Volume 29, page 175, MINES AND MINERALS, was suggested by one of the miners who had been nearly smothered by one of the heavy fire-fighting helmets formerly employed. He advised that a lighter hood be made and attached by a hose direct to the compressed-air pipe, in this way obtaining a suitable air supply. The fire-fighting hoods have been used satisfactorily in other mines of the Anaconda company.

On the morning of November 20, 1901, a disastrous fire at the Smuggler Union mine, in San Miguel County, Colo., caused the death of 23 men, and had it not been for the bravery of a shift boss named Torkelson, who lost his life in warning his men, many more would have perished, as 150 men were in the mine. This fire was due to buildings near the mouth of Bullion tunnel taking fire and setting fire to the tunnel timbers. The fire in the tunnel was prevented from spreading by caving in the mouth with heavy charges of powder. While this was effective, so far as the fire was concerned, it was undertaken too late to save the men, who perished in the mine.

On July 21, 1895, a fire occurred in Block No. 11 of the Broken Hill Proprietary Co., New South Wales. This fire burned for years and cost the company about \$150,000. On September 12, 1897, there was an outbreak of fire in Block No. 12 of the Proprietary company, in which three men lost their lives in being overcome by the fumes in their endeavor to reach the seat of the fire. This mining company has established a fire brigade, the members of which are equipped with smoke jackets and helmets.

The difficulties attending an outbreak of fire underground are scarcely realized by the ordinary individual. A fire on the surface and a fire underground are two very different things. In the first instance there is free vent for the poisonous gases, and therefore the fire fighters can approach the seat of the outbreak and take the necessary steps toward extinguishing it, but underground in such extensive timbered mines as the Broken Hill Co.'s, with their miles of workings, a fire is a very different matter. If it is not promptly extinguished before it attains a firm hold, the poisonous gases given off from combustion, being necessarily confined to the workings, make the approach of the men to the vicinity of the trouble impossible under ordinary conditions. In most of the Broken Hill mines fire buckets and hose are provided throughout the entire length of the different levels, so that nothing may be wanting to enable an outbreak to be promptly extinguished by the men on the spot. Should the fire obtain a firm hold, the first essential step is to provide a supply of fresh air as near to the seat of the fire as possible to enable the fire fighters to approach sufficiently close to play water on it. It is necessary in such cases to secure a constant current of air in one direction to guard against back draft.

In the case of fires in the Proprietary mine, which occur from time to time, experience taught the management that all that could be done was to isolate the affected areas. With this end in view all avenues connected with the fire were closed in order to cut off air supply. This was done in the first instance with canvas stretched across the galleries and later with more substantial barriers built of brick, or with bags of tailing sand plastered over with gypsum to make an air-tight dam. Beyond these barriers water curtains were established. These curtains were made by selecting as narrow a spot in the workings as possible and thoroughly saturating with water a certain length of ground from wall to wall of the road on each side of the fire. All the stopes below are in this manner kept con-

stantly wet from above, and in order to insure that there is no dry timber within these curtains through which the fire may make its way, exploratory cross-cuts are put into them. Should any dry portions be discovered, additional quantities of water are directed toward the spot. Making these exploratory cross-cuts is expensive work, and keeping the curtains constantly saturated may in some instances also be expensive; however, the whole operation of successfully fighting fire underground is necessarily attended by heavy expenditure. Where a road is narrow close to the fire and timbering is not too extensive, it is possible to present a barrier by removing a section of the timbering and replacing it with filling impervious to fire. In other places which may be inaccessible to men, tailing is carried down with water. By these means the fire is restricted, cut off from air supply as much as possible, and slowly smolders itself out. This smoldering process, however, sometimes takes several years. In the meantime the workings outside the area must, by means of ventilating fans, be kept free from any poisonous gases or smoke which may escape from the fire zone. At Broken Hill, in the present system of working in the lower level the timber is neither continuous nor open, and the risk from fire in these stopes is very much less than in the upper levels with their great network of timber.

In the middle of February, 1906, a fire broke out at the Junction mine in Broken Hill. Owing to the smoke and gas penetrating the adjacent workings the fire affected the British North, Junction, and North mines. After 8 weeks' work and an expenditure of \$20,000 the fire still burned and the mine was flooded, which soon extinguished the flames. The unwatering then started, and it was completed about the middle of July. As the water was lowered the necessary repairing of shafts and levels was carried on. One section suffered considerable from the collapse of the timbers and the incomplete filling of the old stopes, which brought on a creep.

On March 23, 1907, when blasting out some old mine timbers on the 500-foot level of the Homestake mine at Lead, S. Dak., a fire which proved disastrous was started. The noxious gases prevented any advances so that men could play water on the fire, and it gradually crawled up to the 400-foot level. After weeks of persistent effort to overcome the fire and when the danger to the men attempting to fight it had become acute, it was decided to flood the mine. The magnitude of the work can be understood better when it is explained that it took practically 4 months to flood the mine at the rate of 11,000 gallons per minute. By this fire 2,000 men were thrown out of employment and an expenditure of over \$1,000,000 was necessary in order to flood and recover the mine. It is not always that fires can be laid to mine timbers, for in several cases the oxidation of pyrite is known to have been the cause.

In the July 20, 1907, issue of *Gluckauf*, Herr Hilt writes that mine fires have to be fought in the Selbeck ore mines of Germany. These mines are worked for galena, blende, copper pyrite, and iron pyrite. The deposit is in Lower Carboniferous alum-schist, which weathers readily and permits the pyrite to oxidize. The temperature of the mine is about 82° F. and when the air-currents are strong the schist commences to burn. At one of the Michigan iron mines a somewhat similar condition occurs, so far as shale and fire is concerned. Rock high in sulphur is on fire in the Youngs mine of the Breitung estate, on the Menominee Range. The company working this property bored through to the surface and capped the opening with a smoke stack up which the fumes from the burning mass are being safely conveyed from the mines.

In November, 1909, sparks from a shifting engine set fire to the London mine head-house of the Tennessee Copper Co. Sparks from the head-house set fire to the shaft timbers and imprisoned 51 men, who fortunately were later rescued.

In February, 1911, a fire occurred in the Tonopah-Belmont mine, Tonopah, Nev., on the 1,166 foot level. The position of

the fire was such that 17 men were smothered because they could not reach the shaft. In this instance, we believe, that two or three other men lost their lives in an attempt to reach and rescue the imprisoned men.

In the Hartford iron mines, near Negaunee, Mich., seven men were recently smothered by the timbering catching fire.

In September, 1911, a fire occurred in the shaft of the Giroux Consolidated mines in Nevada, which caused the death of seven men by cutting off their escape by the shaft.

It is evident that most metal-mine fires have their origin in trivial causes, and provided proper rules were enforced they might be quickly extinguished. The nature of the combustible materials found in metal mines is such that the progress of a mine fire at first must necessarily be slow in a stope, but in the case of a dry-timbered shaft the chances of its spreading quickly are very much better. If a portable chemical engine or even a hand fire extinguisher were available at the start of a fire it could be readily extinguished. These extinguishers, of course, would not be so serviceable in the case of a shaft fire. While it might be possible to extinguish a shaft fire by means of streams of water from the top, a very good plan would be to use automatic fire extinguishers, which are attached to pipes carrying water. In case of a sudden rise of temperature the fusible plug melts and turns on small streams of water which trickle from numerous holes in pipes, which in this case would be placed around the inside at various levels in the shaft. The futility of using steam alone for fire fighting has already been touched upon. The use of carbon dioxide for extinguishing mine fires has never proved satisfactory, although, theoretically, it should smother mine fires.

The Broken Hill Proprietary Co., of New South Wales, adopted oxygen helmets in 1906, as being at that time the most effective means of exploring burning portions of the mine and assisting in combating fires. By the use of this oxygen helmet a number of fires have been extinguished in metal mines. It is, however, cumbersome, and the wearer, being dependent upon a number of delicate valves and parts, is never free from danger.

The Servus apparatus, which has been adopted widely by municipal firemen, has been simplified for use in mines and is an excellent fire-fighting apparatus, and its comparative cheapness, lightness, and safety will appeal to mine managers.

NOTE.—It would be greatly appreciated by the editor if the readers of MINES AND MINERALS would furnish dates and data of metal-mine fires which have come to their notice. It would further add to the movement now going on to reduce mine accidents in metal mines if they would furnish information concerning the cause of the mine fire and the method of extinguishing it.

來 來

Twentieth Meeting of the Electrochemical Society

The twentieth meeting of the American Electrochemical Society was held in Toronto, Can., September 21, 22, and 23. The morning and afternoon of the 21st were spent in the reading and discussing of papers. Luncheon was served at the University. In the evening a smoker and entertainment by Section 2, was held in the main building of the University. On Friday, the 22d, a special train took the members to the Lambton Golf and Country Club, where papers were read and discussed, and luncheon served by the club. The afternoon was devoted to recreation and the evening to a subscription banquet. On Saturday the members went to Hamilton in special cars, where the Canadian Westinghouse Co., and the Steel Company, of Canada, were visited. After luncheon the members went to Dundas by electric cars where the Hydro-Electric Commission's 110,000-volt testing station is located. This pressure is reduced to 13,200 volts and distributed to various cities. After this the meeting adjourned.

A Standard Boiler House

Style of Boiler—Method of Setting—Automatically Dumped Car for Bringing Coal to Boilers

By J. S. Jacks*

The following paper was read at the Annual Meeting of the Lake Superior Mining Institute, under the title "Standard Boiler House and Coal-Handling System of the Crystal Falls Iron Mining Co., Menominee Range."

One of the first questions to be decided in the construction of the power plant is its location. This depends largely upon the location of the shaft, the ease with which coal may be brought to the boiler, and means of storing the coal, especially in the winter.

The first factor, the location of the shaft, is one that has an important bearing upon the location of the boiler house. The building must be so situated that the cable will have as few sharp bends as possible, and still be comparatively close to the shaft. The cost of handling the coal and ashes is usually the largest item in the operating charges. In plants as found at some of the smaller mines, the amount of fuel and ash handled does not warrant the expense of an elaborate conveyor system, which would be justifiable in larger plants. In whatever way the fuel is supplied, provision must be made for storing a quantity sufficient to operate the plant for some time, in case supply is interrupted, to guard against an enforced shut-down.

The type of building should next be considered. It should be as near fireproof as possible, cheap in construction, and should be flexible enough in the design to make it conform to the various local conditions found at the mines and still retain the same general shape or plan. This has been the aim in all of the installations at the Crystal Falls Iron Mining Co.'s properties. One set of drawings has been made and they have been used in the building of all boiler houses, with only slight variations as were necessary at the mine. For lack of a better word this has been called the "standard" boiler house of the Crystal Falls Iron Mining Co. The term is not used to imply that one boiler house is the exact counterpart of another, but that certain features of its construction and details have been so standardized that as a whole it may be termed a "standard" boiler house.

The boiler should be of a type such that its first cost will be low, and still give a maximum efficiency with a minimum amount of expense for its upkeep. As affecting fuel, the type of the boiler equipment is by far the most important part of the power plant and involves the largest share of the operating

expense. It matters not what the initial rate, modern boilers designed in may be "kill" equipment and continued vigilance are required on the part of the operator to secure the best efficiency.

Of the various types and grades of boilers in the market experience shows that most of them are capable of practically the same operating rate per pound of coal, provided they are designed with the same proportions of heating and grate surface and are operated under similar conditions. They differ however with respect to grate arrangement, weight, capacity, cost, cost and adaptability to particular conditions of operation and location. The boiler used by the Crystal Falls Iron Mining Co. is of the fire-tube type. This boiler is simple, inexpensive, and when properly operated is found to be durable and economical. The installation and removal of this type of boiler gives it an advantage over the water-tube boiler, especially in mining work, where the life of the plant is comparatively short. The number of boilers installed at any one plant in no case exceeds six boilers, and as there is always

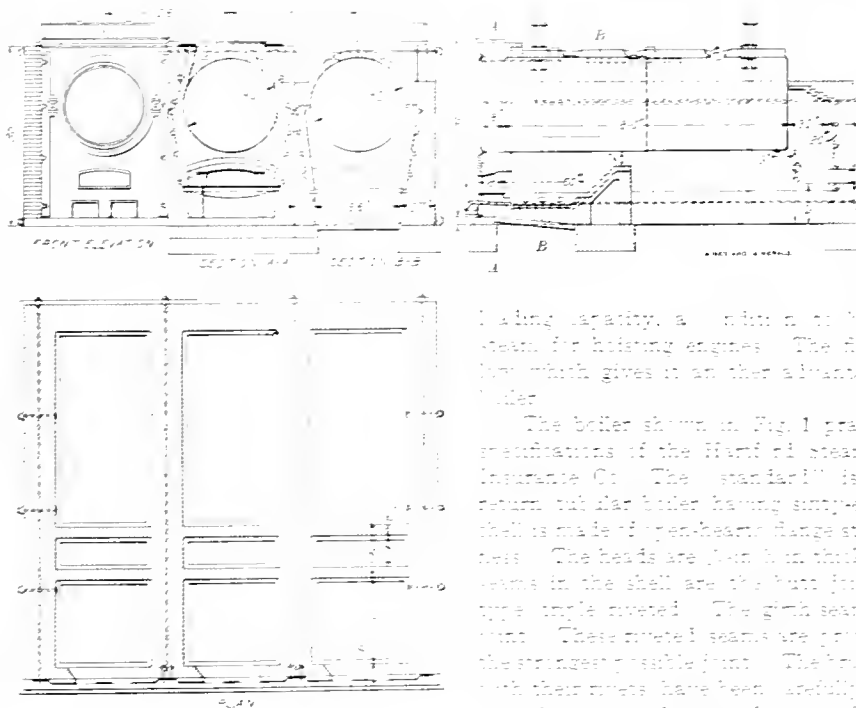

FIG. 1. BOILER AND SETTING

plenty of floor space the addition of extra boilers would only involve the cost of installing the boilers themselves. First cost and small power the return-tubular boiler has a advantage of affording a large heating surface in a small space, and large over-heating capacity, a condition to be desired in furnishing steam for hoisting engines. The first cost of this boiler is low, which gives it another advantage over the water-tube boiler.

The boiler shown in Fig. 1 practically conforms to the requirements of the Bureau of Steam Boiler Inspection and Insurance Co. The "standard" is a 12' 18" horizontal return tubular boiler having six weight 4-inch tubes. The shell is made of open-beams range steel plate 1/2-inch in thickness. The heads are 1/2-inch in thickness. The longitudinal seams in the shell are the butt joint double-covering strip type, triple riveted. The girth seams are single-covered lap joint. These riveted seams are constructed as secure the strongest possible joint. The horizontal seams, together with their rivets have been carefully calculated for the pressure they are to bear, and are so constructed that all parts of the surface are equally sustained. The boiler has a 12' 18" man hole in the front end head and in top shell of the tubes. The front is the full arch flush type. The flush front sets a little more than the extended front for brick and mortar, but it is a real convenient to operate and the boiler is less expensive.

Fig. 1 shows longitudinal section of the boiler setting. This setting is the same regardless of the number of boilers and is made of hard red brick laid in lime or cement mortar, and the entire setting is lined with firebrick up to the center line of the boiler, as shown in the drawing. Every fifth course is laid with headers, so that any part that might become damaged can be easily renewed without taking out the entire lining. In the framing the grate length is 6' 6" less than that of the boiler, and the side wall is battered so as to leave a space at the level where the setting fits into the boiler. The top of the brick wall is 12 inches from the bottom of the shell and the space behind is left empty. During this construction chamber to conform with the shell only reduces its size, which is a disadvantage with horizontal steel. The rear wall is 30 inches back of the rear head, which makes the chamber larger. The back connection, i. e. the connection between the rear wall and the head, is a space of more or

*Crystal Falls, Mich.

less trouble and cost of the expansion and contraction of the boiler. The difficulty of making a joint that will remain tight is avoided as to spring an arch across having one end resting on the wall and the other upon an angle fastened to the side of the boiler. The arch consists of brickwork supported on a wooden framework. Another method used is to place

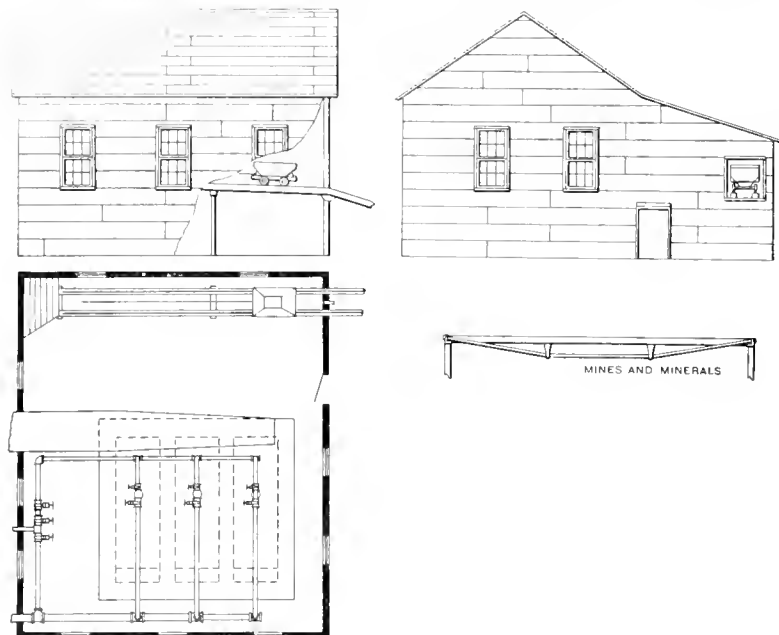

FIG. 2

steel rails across the setting laterally and fill in the spaces between the rails with brick.

It is sometimes difficult with low-grade fuels and natural draft to burn sufficient coal in the grates of a horizontal tubular boiler to produce the evaporization needed. For this reason it is necessary that the grate surface be as large as possible, and have the maximum rate of combustion per square foot of grate surface for the draft obtained.

The suspended support is used, as this seems to be the best method. The boiler, being independent of the walls, does not get out of alinement with the settling of the walls, which is almost sure to occur. When the boiler is set on the lugs the settling of the walls often throws the support of the boiler on two lugs, thus setting up severe torsional strains in the boiler shell. The boiler is set high in front in accordance with general practice. The expansion and contraction of the firebrick causes the boiler to settle in front and it invariably gets lower than the rear end; this necessitates the raising of the front end.

While this setting has been very satisfactory and has given good service it was thought advisable to try some other type of boiler in order to eliminate, if possible, the settling and cracking of the walls. With this in view a Casey-Hedges patented standard steel setting was installed after carefully considering several different types. This setting appears to present means of overcoming the defects in the all-brick setting and still retains the good features of the old setting. This setting does away with the heavy brickwork walls. It is lined first with a layer of asbestos, then a layer of red, and a layer of firebrick. There is a noticeable absence of heavy foundations, the only ones of any consequence being beneath the supporting columns from which the boiler is suspended. The barrel of the casing is semicircular in shape, being practically an inverted Dutch oven, holding the heat to the boiler as the hot gases pass from the furnace over the incandescent firebrick into the combustion chamber. This setting is cheaper to install and requires less brick. The only repairs necessary are the relining of the furnace, thus lowering the cost of maintenance as compared to the brick setting.

In selecting a grate bar that was cheap and would give adequate support to the coal and yet permit the access of sufficient air from below for combustion, it was found that the Wicks rocking grate gives the best service as compared with the stationary grate; while the initial cost is greater the rocking grate outlasts the stationary grate.

The steam line leading to the shaft is connected to an auxiliary 5-inch header, or by-pass, besides being connected to the main header. This affords a means of making repairs or additions to the main header without stopping the mine pumps. This auxiliary line also supplies the feed-pumps. The Hoppes feedwater heater or purifier is used and is the open type of heater. This style of heater has several advantages over the closed type; namely, it is lower in first cost, is more easily accessible for cleaning and repairs, scale and oil do not affect the heat transmission. It has the disadvantage in that the oil becomes mixed with the steam, but by keeping them clean and using oil traps this difficulty is reduced to a minimum.

The means by which coal may be placed within reach of the fireman presents a more difficult problem in a plant of this size than it would be in a larger one. The method used is to make a space similar to a stockpile ground. A trestle is built the entire length of this space and the railroad cars are unloaded from it. A narrow-gauge portable track is then laid from the coal pile to the boiler house and by means of an inclined track laid on timbers the car is elevated above the coal bunkers. A 1½-ton car is used to convey the coal. The car, designed for this, works automatically.

The doors are placed in the bottom and are opened by a system of levers and a spring. A dog engaging a "dump pin," which is fastened to the timbers and is adjustable as to location on the timber, releases a catch letting the doors drop open. When the car starts on its return journey a flat piece of iron attached to the runners, upon which the rails are laid, automatically closes the doors. The car, as shown in Fig. 3,

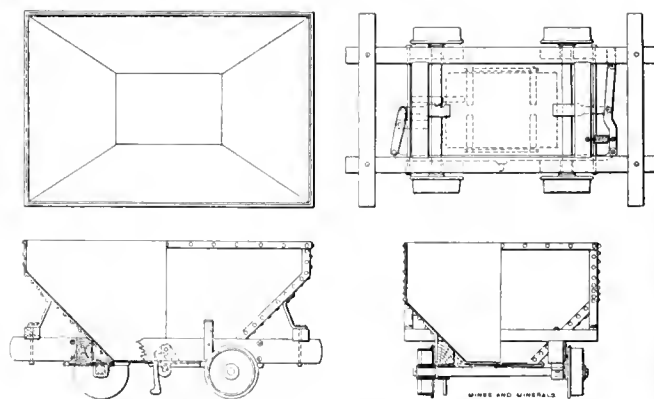

FIG. 3. COAL CAR

is built low in order to make it easier to shovel into. A small hoisting engine in the boiler house is used to pull the car. This method of handling the coal is very simple and can be adapted to suit almost any condition that may arise in the location of the coal pile. The manner in which the car enters the boiler room is shown in Fig. 2.

Oil in Trinidad

It is stated in a recent United States Consular Report that in July a ship was supplied with bunker oil by a local oil company at La Brea, Island of Trinidad. This company makes regular shipments of oil to the United States for refining and is developing a trade in Argentina and other parts of South America.

Mines and Minerals

Vol. XXXII—No. 5. SCRANTON, PA.—DECEMBER, 1911—DENVER, COLO. Price, 25 Cents

PUBLISHED MONTHLY AT SCRANTON, PA.

ESTABLISHED 1881

WESTERN EDITORIAL OFFICE: 1221-1223 First Nat'l Bank Bldg., Denver, Colo.
CHICAGO OFFICE: 1006 Michigan Ave.

Entered at the Post Office at Scranton, Pa., as second-class matter

Address all business communications to MINES AND MINERALS, Scranton, Pa.
CABLE ADDRESS, "RETSOF, SCRANTON"

LONDON AGENTS: INTERNATIONAL BUILDINGS, KINGSWAY, LONDON, W. C.
SOUTH AFRICAN AGENT: MANSION HOUSE CHAMBERS, ALDERLEY STREET, CAPE TOWN.

NEW ZEALAND OFFICE: 63 DIXON STREET, WELLINGTON.

AUSTRALASIAN OFFICE: 83 PITT STREET, SYDNEY.

SUBSCRIPTION RATES

Single Copies.....25 cents
Yearly Subscriptions, including postage:

To United States, Mexico, Cuba, Porto Rico, Hawaii, and Philippines \$2.00

To Canada.....2.50

To all other countries.....3.00

The date after your name on the wrapper is that of the month to which your subscription has been paid. If you do not want to continue your subscription after that time, kindly notify us.

Notice to discontinue or change of address should be sent to the Scranton office.

When notifying us of a change of address always give your FORMER as well as your present address.

Dawson-Mackenzie Coal Fields

COAL geologists will find a new theory in the article on "Weathering of Coal Seams" which is printed in this issue. That there is a mingling of botanical fossils of two different geological periods is interesting, but that coal will weather and leave botanical imprints fails to coincide with the editor's experience or meet with approval. Coal flora are found in strata above and below the coal; in the coal beds, however, all organic matter has been carbonized and so lost its identity. Under such conditions it does not seem probable that, in weathering, coal flora would revert to original forms. It is also difficult to conceive how coal could be converted into clay and at the same time retain its full mass or thickness. The article contains much interesting and useful information on coal in Queensland.

采采

National First-Aid Meet

NEVER in the history of coal mining have such a large number of coal operators, managers, and miners, met at one time in the United States as at Pittsburg, on October 31 last.

The occasion of this gathering was the first National First-Aid Meet, and although the weather was unpropitious and the grounds muddy, the events were carried out with such precision and snap, that the rain failed to dampen the ardor of the contestants or the spirits of the spectators.

The teams taking part in the demonstration came from Alabama, Illinois, Kentucky, Maryland, New Mexico, Ohio, and Pennsylvania bituminous and anthracite fields. Washington and West Virginia, Colorado, Utah, and Wyoming, were represented, but not by teams. When the busy executive officials of large mining corporations leave their business to attend an affair of this kind, it goes a long way toward refuting the statements that appear now and again that operators care little for the safety and welfare of their men. If the general public had seen managers and operators congratulating their men it would have been a revelation as to the relations existing between them. One large operator marched at the head of his men and their band. President Taft took great interest in the events, and frequently leaned over from his box and chatted with the contestants between events. To the spectators and contestants the event will be memorable and the Federal Bureau of Mines is to be congratulated on the successful manner in which the program was carried out.

TABLE OF CONTENTS

EDITORIAL—	
Dawson-Mackenzie Coal Field—National First-Aid Meet, American Mining Congress—Conservation of Coal.....	257
PERSONALS.....	259
REVISION OF MINERAL LAND LAWS.....	260
COAL MINING AND PREPARATION	
PENN-MARY COAL CO. PLANT.....	261
PHOSPHORUS IN COKING COAL, by Charles Catlett.....	263
CORRESPONDENCE—	
The Conduct of First-Aid Contests—Grades for Rope Haul.....	266
NEW FIREDAMP DETECTOR.....	266
COMPENSATION FOR MINE WORKERS, by John H. Jones.....	267
AN ENGLISH COLLIERY ELECTRICAL EQUIPMENT.....	270
BUCKNER No. 2 MINE OF UNITED COAL CO.....	272
THE WEATHERING OF COAL SEAMS, by Tom Coventry.....	273
TRADE NOTICES.....	275
SWIMMING POOLS FOR MINING TOWNS.....	276
OBITUARY—	
James Benton Grant.....	276
WESTERN COAL LAND LEGISLATION, by Geo. Otis Smith.....	277
REPAIRING BROKEN STEEL TAPES, by J. A. Smith.....	278
METHOD OF SUPPORTING MINE ROOFS, by William Griffith.....	279
BOOK REVIEW.....	280
SELF-OILING TAIL-ROPE ROLLER.....	281
THE NATIONAL FIRST-AID MEET.....	282
OVERHEAD ELECTRICAL PRACTICE IN MINES.....	284
TURBINE MINE PUMPS.....	287
COAL MINING NOTES.....	288
EXAMINATIONS—	
Selected Illinois Questions.....	289
ORE MINING AND METALLURGY	
PETROLEUM IN OKLAHOMA, by L. L. Wittich.....	291
AMERICAN INSTITUTE OF MINING ENGINEERS.....	291
COMMON FEATURES OF SILVER DISTRICTS, by W. G. Matteson.....	295
GOLD MINING PROGRESS IN SOUTH DAKOTA, by Jesse Simmons.....	298
THE EDISON CRUSHER ROLLS, by W. H. Mason.....	299
ZINC AND LEAD NOTES.....	300
PROPOSED MODIFICATION OF THE SQUARE SET, by A. J. Moon.....	302
MINING REGULATIONS IN CHINA.....	304
PARRAL TANK AS A SLIME AGITATOR.....	305
ORE MINING NOTES.....	309
CATALOGS RECEIVED.....	311
TOPOGRAPHICAL AND GEOLOGICAL MAPPING, by A. J. Hoskins.....	312
TREATMENT OF BROKEN HILL ORES, by W. Poole.....	315
MILLING AT STRATTON'S INDEPENDENCE, by Philip Henry Argall.....	319
SQUIBS—	
Jet Making in England, 269—Bordeni, Roumania's Newest Oil Field, 276—Production of Natural Gas, 294—Asphalt Lake, Trinidad, 300—Mining in Uruguay.....	320

American Mining Congress

The annual meeting of the American Mining Congress, held in Chicago, most of the general sessions were devoted to important matters pertaining to the coal-mining industry. An important matter that was treated on in papers and discussed by the Congress was governmental interference in the regulation of the coal trade. A paper on the Sherman Anti-Trust Law, with Special Reference to the Coal-Mining Industry, by D. W. Kulm, ably showed one side of such legislation.

It was but natural that the Chicago meeting should be largely devoted to questions pertaining to the coal-mining industry, just as the Los Angeles meeting was devoted to oil mining and metallurgical questions. As the man interested in coal mining is not often interested in ore mining, it seems that it would be a good plan to separate the Congress into two sections, meeting simultaneously, one devoted to coal-mining interests and one to ore mining and metallurgy. Then when each section had thoroughly discussed matters pertaining to its field, and formulated ideas for the advancement of the branch of mining which it represented, there could be a joint meeting and a combination of forces that, working together, would be productive of much good. At the joint meeting, the views adopted by each section could be reported, brief explanations of each measure, when necessary, could be made, and then the entire Congress could ratify, indorse and pledge its support to every rational action of each section. By such a plan greater interest would be taken in the Congress by prominent mining men who do not now attend the meetings, and much more would be accomplished than is now the case.

采 采

Conservation of Coal

TRUE conservation means the utilization of the greatest possible amount of a natural resource with the least possible waste. This can only be accomplished in the mining industry by the skilful extraction of the greatest possible percentage of the mineral in the ground and the utilization of the most improved appliances in preparing the mineral for the market or for use.

In the case of our coal resources true conservation in many fields is only possible by such restrictions in production as will maintain a regular selling price that will be sufficiently high to yield a reasonable profit over the cost of systems of mining which not only allow the extraction of the greatest possible percentage of the coal in the ground, but which will provide for the expensive dead work necessary to mine the coal in thin seams, and to prepare the coal in dirty, slaty, and bony seams, for utilization.

In the past, when coal was mined entirely by individual operators, often men with limited capital, only that portion of the largest seams that could be extracted

with least possible expense, including a deplorable lack of engineering skill and foresight, was taken from the mines. As a result in all the older coal fields, and in some where development has been comparatively recent, only 50 per cent., or even less, of the coal in the seam was mined. In addition the mining was so badly done that the major portion of the coal left in these old workings has been made inaccessible by squeezes, large falls of roof, and other causes that make for extremely hazardous, expensive, and often prohibitive operations.

The advent of combinations of capitalists with large financial resources, has in recent years changed these conditions in some of the coal fields. As a result, a very much larger percentage of the coal is being taken out, and, by the expenditure of liberal sums for engineering ability and improved appliances, the percentage of coal in the ground recovered and utilized is being further increased. Seams that 20 years ago were considered worthless on account of their being only 24 to 40 inches thick, or which while thicker were more or less "dirty," are being successfully worked. This is particularly the case in the anthracite regions of Pennsylvania, where the comparatively limited extent of the fields, coupled with the market demands, result in fair market prices. In the same regions it must also be stated the mines are worked more regularly, the men employed are paid in cash and better paid, than is the case in any other American coal field. In fact, if the muck rakers who write for the yellow journals and still yellower magazines were honest, and would really investigate present conditions in the anthracite regions by interviewing old miners, the older clergymen of all denominations, and especially those of the Roman Catholic church, the older professional and business men, and then describe and illustrate present conditions as compared with those of the past, a great portion of the time of so-called statesmen and politicians at Washington, instead of being devoted to tearing down prosperity could be devoted to economic and helpful legislation.

In addition to really conserving the natural mineral resources, the same large combinations of capital, by the voluntary adoption of improved appliances, and the employment of the most skilful officials obtainable, are conserving the lives and limbs of their employes in a far greater measure than was formerly the case. If the mine owners and mine officials of today were to work the deeper and more gaseous, and in the case of bituminous coal the dustier seams now being mined, in the same manner and with the same appliances as were used 20 or 30 years ago, the toll of killed and maimed mine workers would be several times larger than it is.

The United States government has now a Bureau of Mines, which has not been in existence long enough to produce all the good it eventually will, but it has been in existence long enough for Doctor Holmes and his

assistants to learn conclusively that the statements here made are absolutely correct. These gentlemen are government officials, they are not connected in any way with mining companies, they are men of character and reputation for truth, they are for the most part men skilled in mining. If the Attorney General of the United States, a member of an official family that is at least supposed to assist and support the president in his manifest desire to conserve our coal resources, will consult these gentlemen, and he is actuated by true patriotism, instead of trying to make laws more demagogical than they were ever intended to be, he will try to have them amended or at least construed so that they will not cause a return to "individual competition," or as one able man recently called it "competitive debauchery" which is now the trouble in many bituminous fields and is the cause of cheap mining methods and waste, loss to operators, and only partial time and its consequent deprivations to mine workers.

Coal is the greatest natural asset our country has. On it depends more than on any other resource the material prosperity of the country. Cheap coal to the masses does not mean their prosperity. Coal at reasonable prices does, and it also means conservation of the nation's fuel supply. Reasonable prices for bituminous coal cannot be maintained in most regions by present ruinous individual competition. The lawyers who have no compunctions in charging large and sometimes astounding fees for their own services, who at the instigation of demagogues endeavor to tear down prosperity in regions where it exists, and to prevent its growth where it is badly needed, cannot be too severely criticized.

Personal

Personal

George W. Riter, secretary of the Eureka Hill Mining Co., Salt Lake City, Utah, has recently returned from a professional trip to northern California.

Dr. Jas. E. Talmadge, Belmont Building, Salt Lake City, Utah, ex-president of the Utah State School of Mines, attended the American Mining Congress at Chicago and the First-Aid Meet at Pittsburg.

H. N. Spicer, Cooper Building, Denver, Colo., is in Australia on professional work. Mr. Spicer will be in Denver about May 1, returning by way of the Mysore, India, gold fields.

A. J. Hoskin, E. M., Commonwealth Building, Denver, Colo., has been examining coal properties in Park County, Colo.

George W. Schneider, professor of mining at the Colorado School of Mines, Golden, delivered an address before the mining men of Leadville, Thursday evening, October 26, on "Business Methods in Mining." This was the second of a series of lectures to be given by various speakers in the several mining camps of the state under the auspices of the Colorado School of Mines and the Colorado Scientific Society.

Oscar Cartlidge, mine inspector, has been transferred from the Benton to the Marion district in Illinois.

Frank Rosbottom has been appointed State Mine Inspector of the eleventh district with headquarters at Benton, Ill.

Thomas Back has been appointed mine inspector of the sixth Illinois district with headquarters at Springfield.

Thomas Morgan is now mine inspector in the ninth District of Illinois with office at Belleville.

Raymond C. Benner, of the department of chemistry of the University of Arizona, has associated himself with Prof. R. K. Duncan, of the University of Pittsburg, at which place he will make a study of the smoke problem.

E. H. Wilson, consulting engineer for the Pacific Coast Smelting-Refining-Mining Co., is chief engineer for the Stewart mine, Idaho.

Fritz Cirkel, of Montreal, Canada is consulting engineer of the La Campagnie des Champs-d'Or Rigand-Vaudreuil in Quebec.

F. R. Crocker, of Spokane, has been elected vice-president and general manager of the Boyle Gold Copper Mining and Milling Co.

W. M. Briggs has been elected president of the Carbonate M. and M. Co., at Wallace, Idaho.

A. E. Goodell, of Spokane, Wash., is the northwest representative of the International S. and R. Co., of Tooele, Utah, a subsidiary company of the Amalgamated Copper Co.

Waldemar Lindgren has so far finished his studies of the Tertiary gravels of the Sierra Nevada of California as to incorporate the principal features in Professional Paper No. 72 of the United States Geological Survey.

The firm of Ropes & McIntire, consulting and mining engineers, Helena, Mont., having been dissolved, Mr. Ropes will continue in his profession in Helena with offices at the Court House. It is Mr. McIntire's intention to engage in engineering in southern countries.

Wm. Weston, M. I. M. M., of Denver, formerly mining engineer for the Moffat Railroad, has returned from a 3 months' professional visit to the City of Mexico, and is now making an exhaustive examination and report on the gold and silver property of the Colorado Smelting and Mining Co., near Pitkin, in Gunnison County, Colo.

E. R. Buckley, after 3 years with the Wisconsin Geological Survey, 7 years as director of the Missouri Bureau of Geology and Mines, and 4 years professional service as a mining expert, announces that he has opened an office as a consulting mining geologist and engineer, at 1364 Peoples Gas Building, 122 Michigan Ave., Chicago.

D. W. Obern, professor of geology at the University of Oklahoma, has been appointed director of the Oklahoma Geological Survey to succeed Chas. N. Gould, who has resigned to enter private work. The survey is at work on the oil, lead, and zinc, granite, and iron resources of the state, and separate reports will be issued on each of these products in the near future.

Sumner S. Smith, formerly in charge of Car No. 4 of the United States Bureau of Mines, at Rock Springs, Wyo., is United States Mine Inspector for Alaska, at Juneau.

The *Pacific Miner*, one of the oldest technical journals on the Pacific coast has recently been purchased by the *Mining and Engineering World*, of Chicago.

John N. Pott, now chief mining engineer of the Northwestern Improvement Co., the fuel end of the Northern Pacific Railroad, with headquarters at Tacoma, Wash., was, with his family, a guest of the American Institute of Mining Engineers at Los Angeles and San Francisco. Mr. Pott will be pleasantly remembered by mining men throughout Pennsylvania.

Benjamin W. Vallat, manager of the Newport Iron Mines, Ironwood, Mich., whose paper on the systems employed by his company was one of the features of the recent meeting of the American Institute of Mining Engineers at San Francisco, stopped at Denver for a few days on his way home.

Messrs. Philip and P. H. Argall, manager and superintendent, respectively, of Stratton's Independence, Ltd., Cripple Creek, Colo., are in London attending the annual meeting of the stockholders of their company.

Mark O. Danford has been appointed general superintendent of the Cedar Hill Coal and Coke Co. Mr. Danford will be actively engaged as heretofore with his present firm of Danford & Sanderson, civil and mining engineers, Trinidad, Colo.

W. W. Lindgren, 20 years chief geologist of the United States Geological Survey, resigned recently. Alfred H. Brooks, who succeeded Lindgren as chief geologist of the Survey, will continue his work on the Alaskan Geological Survey.

W. W. Lindgren has been appointed chief geologist of the United States Geological Survey. Mr. Lindgren has been with the survey since 1884, and has a world-wide reputation as an authority on the geology of ore deposits.

W. G. Klodt, designing and construction engineer, has opened an office in the Gunter Building, San Antonio, Tex. Mr. Klodt has been superintendent of construction in the United States, Mexico, and Central America and corresponds in English, Spanish, and German.

O. D. Hogue has been appointed vice-president and treasurer of the Goulds Mfg. Co., of Illinois.

The American Mining Congress and the Colorado Scientific Society, which formerly had joint headquarters at 1510 Court Place, Denver, have separated. The former is at 725 Majestic Building, where E. L. Wolcott is in charge, and the latter in rooms 416, 417, and 418 Boston Building, under the direction of Miss Rebecca Riddle, assistant secretary.

Leroy A. Palmer, formerly of Salt Lake City, and an occasional contributor to the columns of MINES AND MINERALS, is now geologist for the Forestry Service, with headquarters in the Majestic Building, Denver.

It is announced that George W. Bowen has resigned the presidency of the Victor-American Fuel Co., of Colorado. Mr. Bowen has been with the company for many years, having been one of its founders in the early days of coal mining in Colorado.

E. B. Taylor, of Williamsburg, Ky., has been appointed general manager of the recently organized Bon Jellico Coal Co. Arthur Groves, of Knoxville, Tenn., is president of this new company, which has 1,250 acres of coal near Jellico, Tenn.

W. W. Taylor, who for a number of years has been general superintendent of the St. Paul Coal Co., has been elected president of that company. The present headquarters of the company, which are in Chicago, will be moved to the Maloney Building in Ottawa, Ill.

F. E. Fernekorn, former chief clerk of W. W. Taylor, has been elected secretary of the St. Paul Coal Co. His headquarters will be at Ottawa, Ill.

Harry S. Brady, who for 8 years was with the Youghiogheny and Ohio Coal Co., later with the Charleroi Coal Works, is now associated with W. J. Huston, manager of Ohio for the Moreland Coke Co., of Pittsburg. Their office is in the Rockefeller Building, Cleveland, Ohio.

來 來

Revision of Mineral Land Laws

The American Mining Congress, at its recent Chicago meeting, requested that Congress shall undertake a general revision of the mineral land laws of the United States.

The Mineral Land Laws of the United States and Alaska, framed in 1872, and interwoven with a mass of supplementary state legislation, differing in every state, fail to meet the present requirements of the industry. Moreover they have developed various evils, the numerous effects of which are steadily increasing. These have become so serious as to retard the development of mining and to create dissatisfaction and complaint everywhere.

At every annual session of the American Mining Congress during the past 12 years the prevailing discontent with the present code has been voiced by various resolutions calling attention to its evils and asking for the correction of this or that feature of the laws relating to mineral claims located upon the public domain. Such complaints steadily increasing in

volume have found expression not only in the Mining Congress but also in the press of the mining communities, all the mining journals, in the societies of mining engineers, and in fact through every medium available for the expression of public sentiment. They have nevertheless been without result, for the reason that the mining laws are largely interdependent and it is difficult, if not impossible, to correct one fault without straightening out the entire code. Moreover, the states affected, some of which have often attempted to make improvements, find that nothing effective can be done without the action of Congress. In short, patchwork is impossible and a general revision is necessary.

Since the problems involved in the work are peculiar to the industry and are unusually difficult, it is evident that their satisfactory solution will require the aid of the most experienced judgment together with a free and direct expression of views by the mining communities themselves. Among the many questions which will arise during a revision are the following, which will illustrate the nature of the work.

Some of the problems are:

The Apex law, with the uncertainties of title and litigation caused by it. The latter includes not only the conflicts caused by the extra lateral right but also those occasioned by the consequent shapes of claims and the overlapping of lines.

The creation of a definite procedure for acquiring rights to those claims in which the mineral is not near the surface and where discovery must in consequence be long deferred.

Tunnel locations and the uncertainties of title caused by them in neighboring claims.

The present non-observance of the law of discovery.

The partial or complete non-observance through various expedients of the law of assessment.

The location of an unlimited number of claims by one individual.

Locations by proxy.

A general revision now will be particularly timely, because of the public interest in conservation and the new legislation now under consideration for timber, oil, phosphate, and coal lands, and also power sites. To omit the "Mining Code" from any program for the betterment of laws relating to natural resources, would be to pass by the field where relief is most urgently needed.

The American Mining Congress at its last annual session therefore reached the following decision:

"That Congress be asked to undertake promptly a general revision of the mineral land laws, which in view of the difficult problems presented should be in cooperation with the mining industry. The plan adopted for this cooperation should give all sections opportunity for public hearing and the discussion of remedies. The Mining Congress will suggest a practical plan for this purpose later on if desired."

In requesting action upon this matter it is therefore suggested that if Congress will authorize a committee to act, the representatives of the American Mining Congress will be pleased to furnish such detailed information and suggestions as may aid the committee in preparing a plan, whether for a commission or otherwise, which will accomplish the ends desired. A joint resolution like the following is suggested:

"That—Committee—is instructed to prepare and submit at this session a mode of procedure whereby Congress may undertake a general revision of the mineral land laws of the United States in the way which will best promote the public welfare and meet the peculiar needs of the mining industry. The plan recommended should provide a practical means whereby Congress may utilize the best experience and judgment available in the industry and which will give the mining regions of the United States and Alaska ample opportunity for public hearings and the discussion of remedies."

COAL MINING AND PREPARATION

Penn-Mary Coal Company Plant

Description of Tipple, Combined Electric and Tail-Rope Haulage, and Power Plant Arrangements

In the central eastern part of Indiana County, Pa., the Penn-Mary Coal Co., named after the Pennsylvania and Maryland Steel companies has five mines in operation and three more in the course of development. The company started operations in 1904, and since it is not a commercial coal operation in the strict sense of the term, because coal is shipped only to the steel companies, not much is known concerning its excellent equipment and location except possibly in the immediate vicinity. To reach these mines which are high in the Alleghany Mountains it is necessary to take the Cherry Tree and Dixonville branch of the Pennsylvania and the New York Central railroads, running from Cresson and Clearfield respectively to Possum Glory, a station near the mining town of Heilwood.

The coal mined in this vicinity is the Lower Freeport or D' bed of the lower productive coal measures. This coal when low in sulphur makes an excellent coke, but as the bed is apt to vary in this element, the company keeps tab on it by taking samples from the headings and rooms and analyzing them weekly. If the coal in any one heading is high in sulphur it is kept separate from the coking coal and used either at the mine plant or at the steel plants for boiler fuel until there is a change in composition. If local changes that here and there temporarily alter conditions be neglected, the following may be considered as an average section of the D' bed with adjacent floor and roof rocks:

Floor, fireclay resting on Freeport limestones; coal from 36 to 42 inches; draw-slate from 6 inches to 2 feet; coal from 2 to 3 inches; hard slate up to 20 feet thick with Freeport sandstone above. In this particular locality the B bed is about 140 feet below the D', but crops out at only one point near center of field, therefore most of the seam must be reached by shafts, while the operations in D seam, at Possum Glory, with the exception of No. 3 mine, are drift mines. The pitch of the bed in the main entries is about $1\frac{1}{2}$ per cent. The butt entries, however, have a pitch of about 4 per cent. Owing to the bed being comparatively thin it is necessary to take down the roof in main entries for headroom and make them from $5\frac{1}{2}$ to 6 feet high above the rail. Most of the

main entries are driven with an average width of 10 feet; Mine No. 2, however, has 18-foot wide main haulage entries for double tracks. In some places it is necessary to timber the entries. As a rule, however, the roof arches and becomes safe without timber. Cross-entries are driven 18 feet wide, the extra width being used to store the rock taken from the roof to gain height. The main entries to these mines are equipped with electric bulb lights, and mines Nos. 1, 2, and 3 are supplied with Stromberg-Carlson Co.'s mine telephone system. To hasten development Pneumelectric coal cutters are used in headings; in No. 1 mine they are worked day and night.

The mines are worked on the double-entry system, cross-entries and rooms having 50-foot centers, the rooms being 26 feet wide. Owing to the low bed, the cars are made necessarily small in comparison with some other mine cars. The Penn-Mary mine car, shown in Fig. 3, is 33 inches high, 60 inches wide; has 12-inch gauge, and 24-inch wheel base. The capacity of these cars is 1.2 tons, and with the exception of the single drawbar iron, the brake lever at the rear of the car, and chain-haul hook underneath, the cars do not differ materially from



FIG. 1. STEEL TIPPLE AT NO. 2 MINE, HEILWOOD, PA.

others of the wooden type. Owing to the bumping and jerking to which mine cars are subjected the bolts fastening the axle boxes gradually enlarge the holes in the plank car bottoms so that in time the car body has a swaying motion that may exceed the safety point or at least require repairs. For this reason Superintendent Dowler will probably replace the old car-truck system with the angle-bar truck of the Hockensmith Wheel and Mine Car Co.

Haulage from No. 1 mine is a peculiar combination of head-rope and a Baldwin-Westinghouse electric locomotive acting as a Barney. The main entries at this mine are 8,000 feet long with a $1\frac{1}{2}$ -per-cent grade and at times more. Cars are run in trips of from 35 to 65, and this being too much for a 12-ton

locomotive, the locomotive and trip are hauled from the mine by a 400-horsepower, Lidgerwood steam haulage engine winding 7,500 feet of $1\frac{1}{2}$ -inch rope. On going in the mine the locomotive pulls the empty cars and hauls back the wire rope. The arrangement is a most satisfactory one and is believed to be the first haulage system of this kind on record. Nos. 2, 4, and 5 mines have straight electric-locomotive haulage, while the slope No. 3 mine has an engine plant with an electric hoister.

The Penn-Mary steel tipple at No. 2 mine is made long, as shown in Fig. 1, so as to span the ravine and receive car from three mines on a level with No. 2

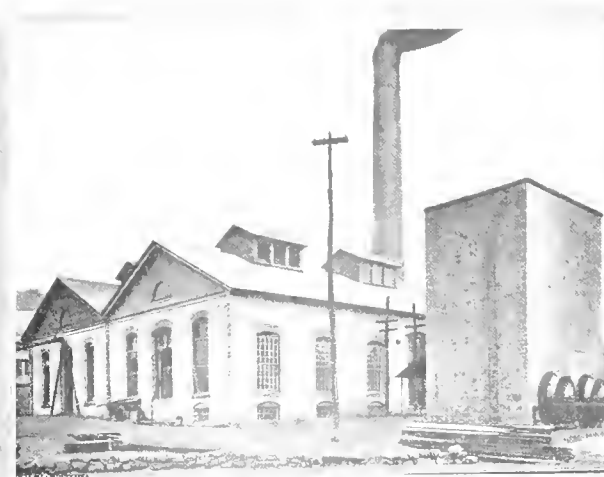

FIG. 2. POWER PLANT AND COOLING TOWER.

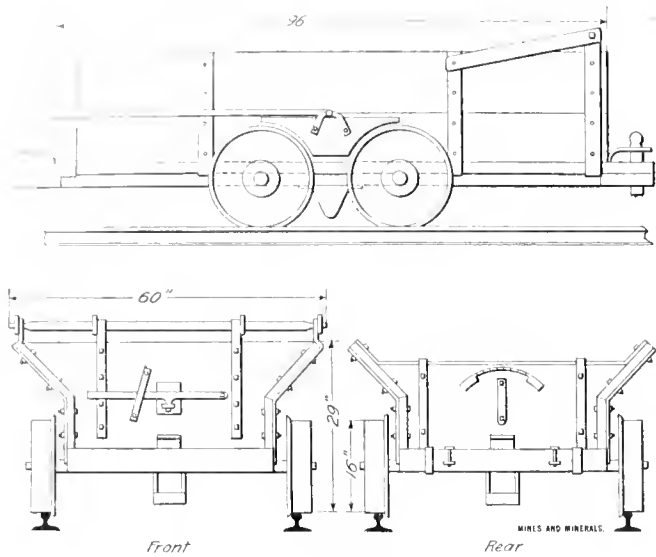

FIG. 3. MINE CAR, PENN-MARY COAL CO.

mine. The tippie, which was designed and erected by the W. G. Wilkins Co., of Pittsburg, has about all the modern improvements of an up-to-date colliery structure. A plan of the main tippie floor is shown in Fig. 5. The cars come to the three Phillips cross-over dumpers at *a* in trips of from 50 to 65. Here the cars are moved forward as desired by the chain trip feeders *b*, and as fast as uncoupled, usually at the rate of four per minute, they are dumped onto the $\frac{3}{4}$ -inch screen. It will be noticed that there are three dumpers on this floor, two on one side of the tippie floor and one on the other. After dumping, the cars run down an incline to the kickbacks *d*, then back switch to a short inclined chain haul *e*, by means of which they are raised to the main tippie floor and cared for by the trip makers *f*. In case one dumper is in need of repairs the cars are run to the dumper on the other side of the tippie, a feature which saves delay inside and outside the mines. Under the tippie there are three curved loading chutes arranged to discharge the coal in the center and toward the ends of the railroad cars. At the second opening to No. 2 mine there is installed one of the latest improved J. C. Stine's centrifugal fans. It is 12 feet in diameter, is installed in a steel fan house and is driven by a noiseless Morse steel chain attached to a 100-horsepower motor. At present the fan is delivering 140,000 cubic feet of air when running at 150 revolutions per minute with 2 $\frac{3}{4}$ -inch water gauge and one motor. When more air is needed in the mine than this one motor can furnish, arrangements have been made so that a duplicate motor can be attached to the shaft on the other side of the fan.

The power house shown in Fig. 2 is at No. 1 mine. The water-cooling tower, shown to the right, is supplied with four 8-foot-diameter disk fans, driven by 40-horsepower direct-current motor, with the object of cooling the hot water trickling

down from the top and which is used over and over to condense steam in a condenser. Around the circumference of the disk fan housings there are steam pipes perforated with holes and supplied with valves. In winter, if there is any danger of the moisture at the intake to the fan freezing, the valves are opened to admit steam to the pipes and it escaping from the small holes mentioned prevents ice forming. An arrangement of this kind at the intake of a blowing fan would increase the humidity of mine air. The original plant for generating direct current consisted of four 300-horsepower, high-speed, Fleming, side-crank engines, each of which carried a 250-volt direct-current generator, as shown in Fig. 4. As the demand for power increased with the development of the mines, it was decided to install a Westinghouse low-pressure turbine, as it was shown possible to obtain additional power from the same steam and boiler fuel with only the additional use of the necessary condensing water. The turbine installed is a 750 K. V. A., 2,400-volt, 3-phase, 60-cycle, alternating current, operating at 3,600 revolutions per minute, shown in Fig. 6. This turbine when taking steam at atmospheric pressure from the 300 horsepower engines shown in Fig. 4, and operated in connection with the condensing machinery shown in Fig. 7, will deliver 1,000 horsepower at 2,400 volts for local use or for transmission to the outlying operations. In the illustration, Fig. 6, the generator is shown on the left and the low-pressure turbine on the right. The vacuum varies from day to day according to the density of the atmosphere and is normally 27 $\frac{1}{2}$ inches.

The plant is not at present loaded to its full value, but with the improved conditions, due partially to the higher voltage transmission for outlying points and due to the better combined economy of the reciprocating engines and the low-pressure turbine, it has been found that a saving of about 7 $\frac{1}{2}$ tons of coal per day is made over the work actually done previously by the non-condensing reciprocating engines.

In order to obtain so much vacuum the exhaust steam must be thoroughly condensed and this is accomplished by

the condenser and machinery shown in Fig. 7. The steam enters the condenser *a* from the turbine through the pipe *b*; as it enters it meets a spray of cooling water coming from the

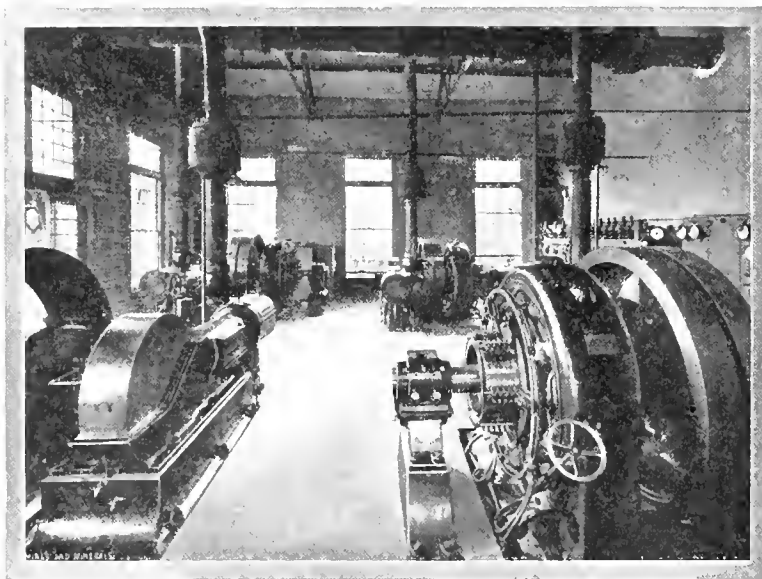

FIG. 1. INTERIOR OF POWER HOUSE

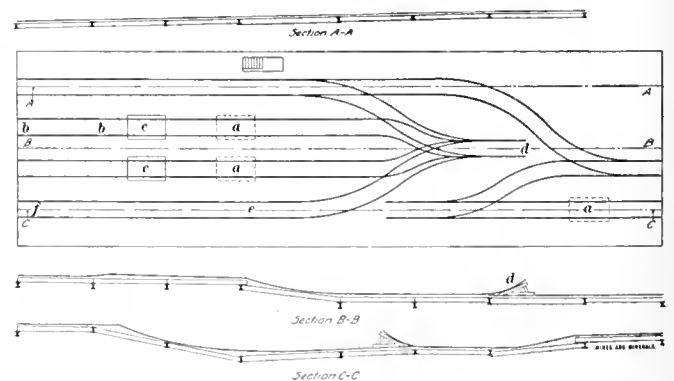

FIG. 5. PLAN OF TIPPIE FLOOR

cooling tower through pipe *c*. As the water from the intake falls through the condenser it is caught in the hot well below and lifted to the cooling tower by the two centrifugal pumps *d* which use the pipe *e* for the discharge. On the common pump shaft there is a Westinghouse high-pressure non-condensing steam turbine *f* that receives the live steam to run it at 1,200 revolutions per minute, direct from the boilers through pipe *g*, and exhausts through pipe *h*. All steam pipes are surrounded with W. H. Johns-Manville Co. pipe covering, to prevent radiation and condensation. Whatever condensation there is in the exhaust pipe *h* is caught in the condensed-water pump *i* and returned to the boiler feedwater heaters. To the rear and right of the condenser is a tank *j* which contains cylinder oil trapped from the engine exhaust previous to its entering the low-pressure turbine. The entire power plant is kept neatly, and evidently the engineers are proud of their machinery. To the rear of the engine room and entirely separated from it by a brick partition and wooden door is the boiler room where the boilers are hand fired.

About one mile from the power house there is a substation near No. 2 mine where the 2,200-volt alternating current is stepped down by a rotary converter to 250-volt direct current. At this mine the fan and the tippie machinery are operated by alternating current and the three Baldwin-Westinghouse electric locomotives, the Pneumelectric coal punchers, the electric hoist for No. 3 mine, two Aldrich power pumps, electric lights for mine and the tippie and the auxiliary repair shop receive their power from the substation. To the left of the power house, shown in Fig. 2, is the engine house in which the 400-horsepower haulage engine mentioned as assisting in the haulage at No. 1 mine is installed. Near here, but not shown, is the roomy machine shop, where all mine cars are built and repaired, and where ordinary machinery repairs are made.

Near the No. 1 mine there is an electrical repair shop in which armatures are wound and other motor repairs made to the electrical machinery. At this mine Baldwin-Westinghouse electric locomotives, Allentown electric pumps, Pneumelectric coal cutters, tippie machinery, shop machinery, two deep-well pumps for Heilwood's water supply, electric-light plant for the same town and for the mine are driven by power from the central plant already described.

The fan at the Penn-Mary No. 2 mine is of the J. C. Stine make. It was put in at night so that not a single day's time was lost in the mines. Since its installation it has been running 150 revolutions per minute 24

hours daily, and furnishing 140,000 cubic feet of air, at 2½-inch water gauge. Because of the excellent design and mechanical workmanship the fan furnishes more air with less consumption of power than a 16-foot diameter fan of another make at No. 1 Penn-Mary mine.

The author is indebted to Superintendent H. P. Dowler who so kindly accompanied him and explained the different points of interest about the Penn-Mary mines. He states that it is planned that in the near future a central drainage plant using centrifugal pumps run by electric motors will be installed in the No. 1 mine for handling the drainage of the whole mine.

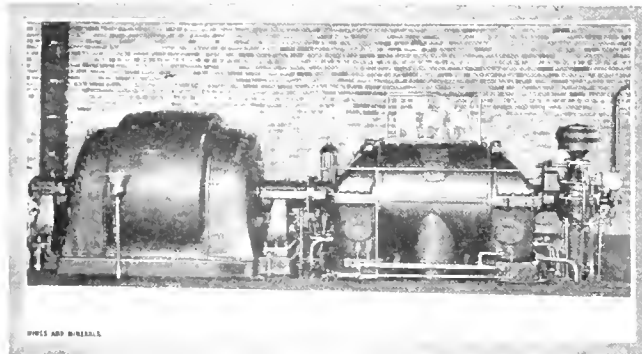

FIG. 6. LOW-PRESSURE TURBINE GENERATOR

it may not be without interest to note the form in which phosphorus exists in one particular coal seam.

In the examination of what is known as the Big seam, which outcrops a few miles west of Columbiana, Ala., my attention was called to the distribution through the coal, in the form of minute veins and particles, of a resinous-looking substance. A small amount of this was selected, and was provisionally identified as evansite ($Al_6P_2O_{14} \cdot 18 H_2O$).

Subsequently, through the courtesy of Dr. Sharshall Grasty, of the Geological Department of the University of Virginia,

I was able to secure an additional amount of material, which was purified down to about .3 gram. This was examined by Prof. John J. Porter, of the University of Cincinnati, and gave the following partial analysis:

	Per Cent.
Loss on ignition	37.43
Phosphoric anhydride	10.33
Alumina	36.33

There was also a trace of silica, and quite a considerable quantity of lime and magnesia.

Professor Porter was led to think that the material was not pure, but a mixture of several of the phosphates of aluminum carrying lime and magnesia. The material available did not permit of the convenient determination of the other ingredients.

One form in which phosphorus occurs in coal is evidently as a hydrated phosphate of aluminum; and any coal which shows to the eye the occurrence of a light-colored resinous-looking material should be looked on with suspicion as being high in phosphorus.

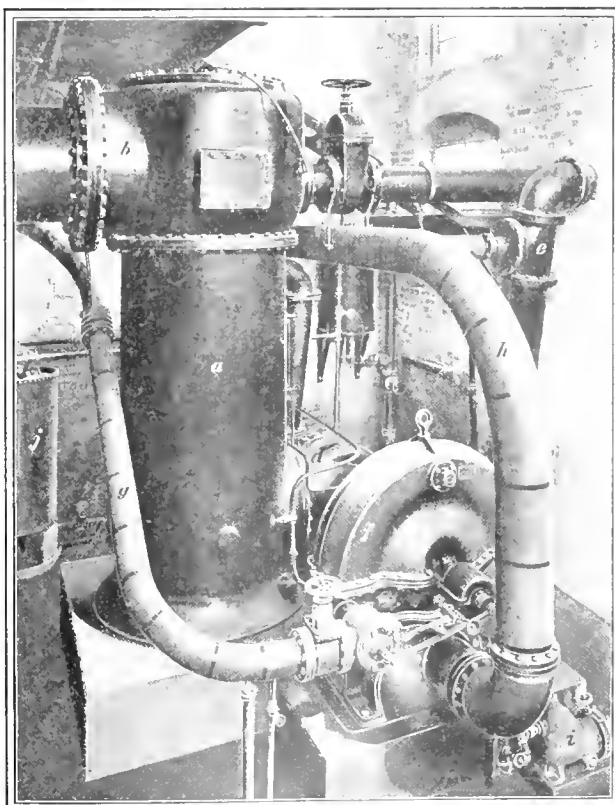

FIG. 7

來 來

Phosphorus in Coking Coal

By Charles Catlett

The following paper was read at the San Francisco meeting of the American Institute of Mining Engineers, October, 1911. While the occurrence of phosphorus in coking coal has assumed less importance with the development of the open-hearth method of steel making,

Haulage System at Gray Creek Mine

The Haulage Problem Solved by Utilizing the Natural Features of the Location

By F. W. Whiteside*

Gray Creek mine of the Victor-American Fuel Co. is, strictly speaking, not a new camp, being one of the older mines of the Trinidad district. It is situated in Las Animas County about 8 miles southeast of Trinidad, Colo.

A few years ago mines Nos. 1 and 2 encountered a large fault, which at its maximum, displaced the coal 110 feet. It was found impracticable to tunnel into the vein in its new position beyond the fault as the coal disappeared entirely for a short distance immediately beyond it. A new mine ahead of this trouble was therefore located and developed.

The portal of the mine is situated at an altitude of 7,285 feet above sea level and the elevation of the railroad track under the tippie on which its coal is loaded is 6,986 feet, a vertical drop of 299 feet in a horizontal distance of 6,314 feet, an average fall of 4.74 per cent.

This line is over the shortest practical route which could be selected. Could the line have been made reasonably straight, the haulage problem would have been comparatively simple. Owing to the topography of the country, an outside line for electric motor haulage would have been practically 2 miles in length. A shorter and straighter line suitable for rope haulage would have required a rock tunnel at least 1,200 feet long to cut through a hill which was much too high to attempt with an open cut.

The route finally selected utilized two principal features which had a great deal to do with cheapening the cost of this line. These were a natural inclined plane 2,200 feet in length which required scarcely any grading, excepting some drainage ditches and the haulage entry in the old mine which provided a 900-foot tunnel through the hill also referred to. The latter required a certain amount of timbering and cleaning up of old falls, but this was not an item of serious expense.

After a number of surveys, the line finally constructed was located with the following grades: 950 feet of 3.30 per cent., used as the top landing; 1,575 feet averaging 6.985 per cent., used as a gravity plane; 625 feet of 3.28 per cent., 1,364 feet of 4.402 per cent., 100 feet of 3.67 per cent., through the old mine entry, and 910 feet averaging 2 per cent., from the portal of the old mine to the tippie, which is 26 feet above

the top of rail on the loading track. These grades were all in favor of the loaded trips.

The pit mouth, as located, is 23 feet vertically above the coal. To reach the latter a 10-per-cent. slope driven practically on the pitch of the seam was completed. It was 335 feet in length and for the greater part of the distance was driven in very hard sand rock. When the coal was reached the pitch of the slope became that of the coal or 3.32 per cent.

By referring to Fig. 4, it will be seen that a three-drum rope hoist was selected to operate the haulage on the mine slope and the gravity plane. The machine selected was furnished by the Wellman-Seaver-Morgan Co. No. 1 and No. 2 drums are 6 feet in diameter with 3 feet 4 inches face, drum No. 3 is 3 feet diameter with 1 foot 4 inches face. These are so arranged that they may be operated separately or simultaneously. No. 1 drum is equipped with one 6-foot band brake and one 6-foot friction clutch. Drum No. 2 has two 6-foot band brakes and one 6-foot friction clutch. No. 3 drum has a 47-inch band brake and a 36-inch friction clutch. The hoist is driven by a General Electric, 300-horsepower, 440-volt, three-phase, 60-cycle, 600-revolutions-per-minute electric motor with magnetic contactor equipment and resistance, operated by a master controller. The entire machine weighs 94,000 pounds.

The maximum rope pulls specified were as follows: No. 1 drum, hoisting, 13,000 pounds; No. 2, breaking, 13,000 pounds; and No. 3 drum, breaking, 4,500 pounds.

Seven-eighths-inch, plough-steel, seal-lay, 6-strand, 19-wire rope is used on drums 1 and 2, and ½-inch wire rope of the same description on drum No. 3. This rope was selected on account of its quality of combining great flexibility and strength.

The operation of the haulage is as follows: The main rope winding on drum No. 1 draws the loaded trip up the slope to a position at which the lower end is approximately 25 feet above the 18-inch sheave wheel set under the drill hole which is indicated but not shown in Fig. 4. The ½-inch rope (No. 3) is now attached and the trip continues its way out of the mine and over the knuckle until the position *B-C* is reached, the point *B* being about 20 feet ahead of the large sheave wheel *A*. No. 1 and No. 3 ropes are detached and rope No. 2 is attached at the *B* end of the trip. As it is now standing on a 3.30-per-cent. grade the trip starts itself and rolls down the plane under the control of rope No. 2 until the motor landing at *F-G*, Fig. 5, is reached. Here an electric haulage locomotive takes it to the tippie and returns with a trip of empties.

At the foot of the plane *F*, No. 2 rope is now attached to the trip of empties and lands them at *D-E* where it is detached

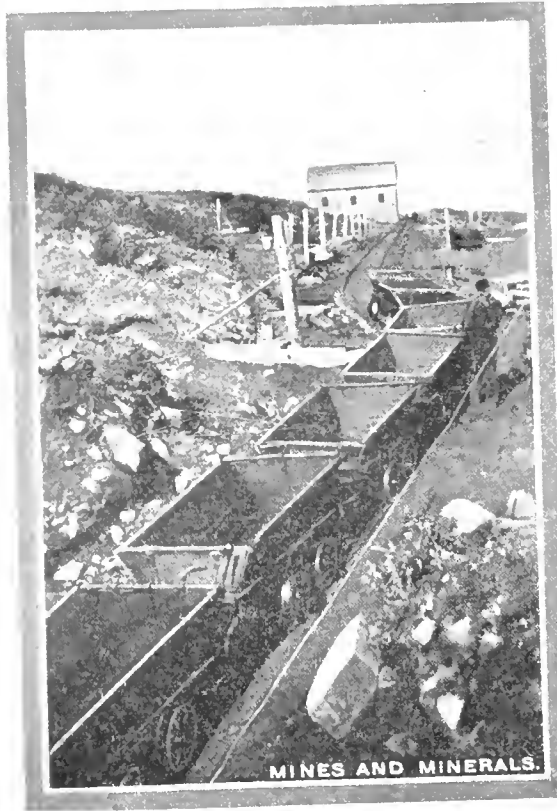

FIG. 1. LOOKING DOWN PLANE FROM NEAR WHEEL A

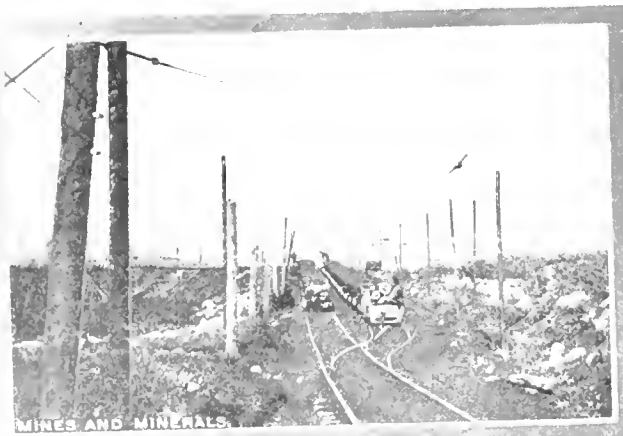

FIG. 2. MOTOR LANDING F-G

*Chief Engineer, Victor-American Fuel Co., Denver, Colo.

and No. 3 rope substituted in its place. No. 1 rope is also attached to the E end of the trip. No. 3 rope now draws the empty trip over the knuckle and down into the mine to approximately the same position as that in which the loads stood when No. 3 rope was attached to the previous loaded trip. No. 3 rope is now detached and the trip continues to the distributing parting under the control of the No. 1 rope.

As arranged, the hoist can handle a trip on the mine slope at the same time that it is moving one on the gravity plane outside. They may be also handled separately, at the option of the operator.

Drums Nos. 1 and 2 develop a rope speed of 600 feet per minute, while hoisting. When lowering trips the speed is governed entirely by the condition of the cars and track. Drum No. 3 is good for a rope speed of 300 feet per minute, but as the distance traveled is short, a much lower speed is maintained.

The regular trip consists of 20 cars with an aggregate weight of 100,000 pounds when loaded with coal. The ultimate capacity of the mine will be 1,000 tons of coal per day.

The hoist-building construction consists of a steel frame covered with hyrib and plastered with cement mortar. The electric transformers stand on one side of the room near the wall. The hoist is equipped with indicator dials which show

the location of the trips but the operator is governed by electric signal bells entirely.

From Fig. 4, it would appear that the hoist is set at a greater distance from the pit mouth than the requirements of the case demanded. Its location was determined by the topography of the ground. A site closer to the mouth of the mine would have placed the machine in a heavy fill, necessitating a great quantity of concrete in the foundations. The location also permits a longer lead to the first supporting rollers.

As before stated No. 3 rope is taken into the mine through a drill hole. This is cased with 10-inch rope pipe and is 61 feet from the surface to the top of the coal. It is located on a line perpendicular to the face of the drum at its center.

The total cost of the installation including tram line, hoist, motor wiring, and hoist building was \$32,008.

采 采

The power required to drive a fan varies directly as the cube of the number of revolutions. If a fan is running 80 revolutions per minute and requires 25 horsepower to drive it, what power will be required to drive the fan at 160 revolutions per minute? Stating the proportion thus: $(80)^3 : (160)^3 :: 25 : x$, then $x = 200$ horsepower.



FIG. 3. LOOKING DOWN GRAVITY PLANE FROM PIT MOUTH

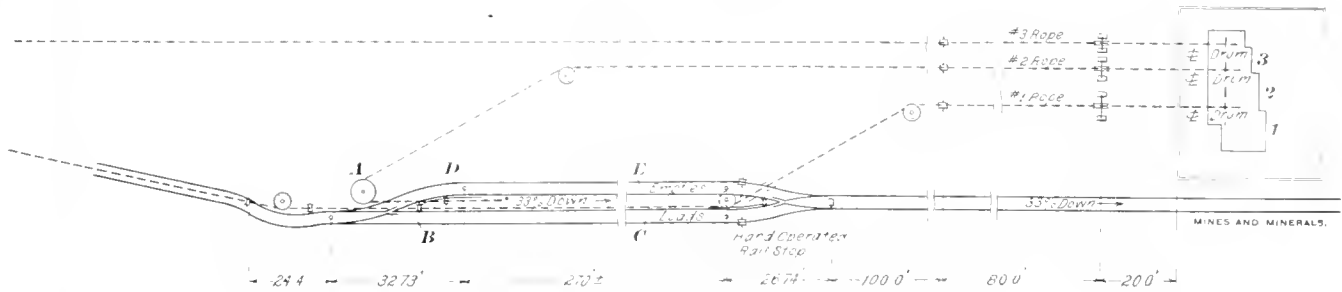

FIG. 4. PLAN OF HOIST AT GRAY CREEK MINE

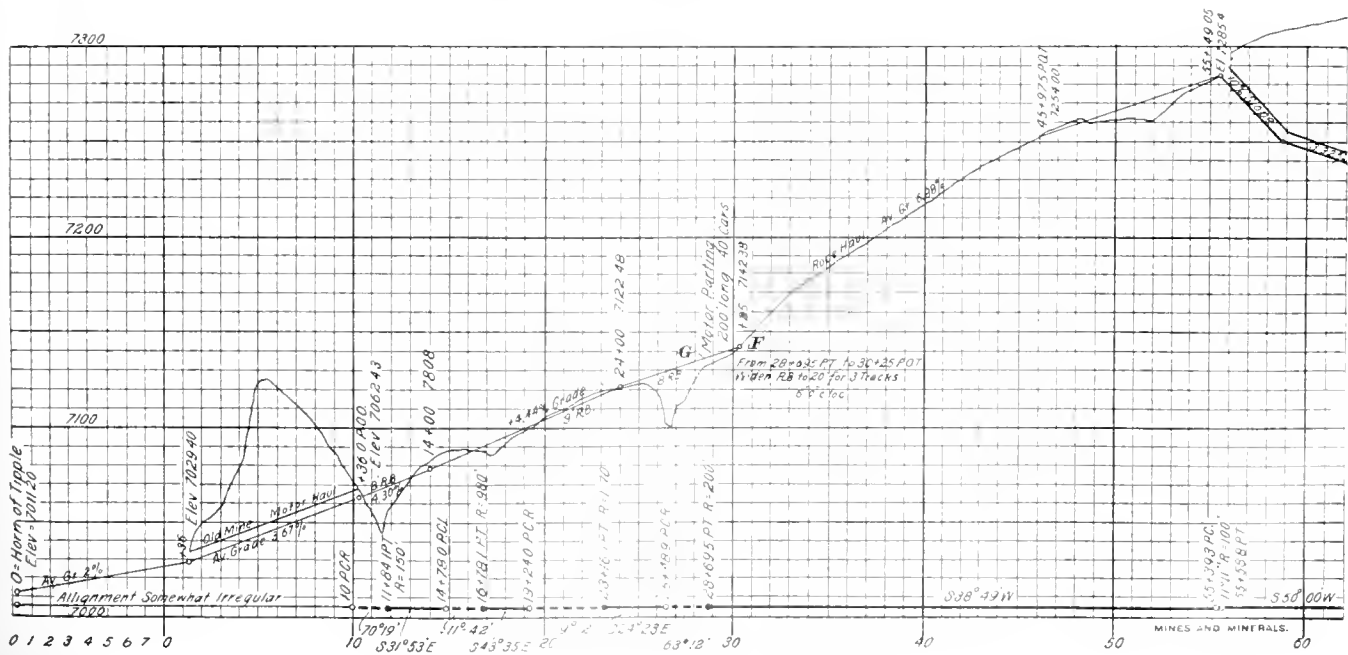

FIG. 5. ELEVATION AND Haulage GRADES



Correspondence



The Conduct of First-Aid Contests

Editor Mines and Minerals:

SIR:—The recent miner's contest at Trinidad was an event of great interest, but unfortunate in that so little time was allowed it was impossible for the judges to do full justice, and consequently much ill feeling was aroused, especially in the first-aid contest. Since it is hoped that these teams will continue this work, and contest in events annually, it is but just to call attention to certain mistakes that were made. The experience of our team will well illustrate these mistakes.

The first event was as follows: Man's left hand mashed, bones crushed, and cut in palm of hand (slight). Dress with first-aid packet. In every contest we must be governed by the rules of the game, that is the instructions, and I submit that these instructions limit the man to first-aid packet alone, which contains no splint. In support of this contention I refer to the American Red Cross Bulletin, July, 1911, page 61, where this identical injury is given with instructions to dress with first-aid packet and apply splint. Believing that he must follow instructions to the letter our man dressed the injury perfectly without a splint and was deducted five (5) points for so doing. In the second event, "man lying on live wire, burned on back, treat," our team was deducted five points for not withdrawing tongue, although a number of physicians standing by were criticizing him for first pulling out tongue with forceps and then tying out. These deductions lost us 10 points and the cup, and greatly provoked the team, knowing that they were due entirely to misunderstanding and oversight.

Our opinion is that instructions should not be specific, but simply say dress or treat, thus testing the team's knowledge as to what is proper.

We are of the opinion that no physician or surgeon not having special knowledge of a mine's interior and conditions to be found there, is a competent judge. What physician would think of safety lamps to combat shock, or could dress a fractured clavicle with a pad and one triangular bandage, meeting all indications and having the arm in a sling? What physician not familiar with a mine's interior is able to judge as to best apparatus for handling spinal injury? The decision was, no doubt, greatly influenced by the equipment of the winning team, indeed, the physician presenting the cup made special mention of their original equipment and methods. Yet in what mine can such material be found, or in what mine is supplied with an outfit? Certainly, few miners wear bandanna handkerchiefs, and tin is hardly to be found at all. An improvised stretcher may be useful on rare occasions, but who does not prefer one ready made. This may have been a splendid exhibition of first-aid materials used many years ago, but not of those in use today.

The English government requires that an ambulance box provided by St. John's Ambulance Association, or similar box, be kept at mine. The United States government recommends the Red Cross cabinet which is to be found in most mines today, but it seems to have been decided that such outfits were not practical.

We believe credit should be given for the most carefully devised and practical equipment, and thus will the first-aid man who handles the injured and knows the difficulties with which he has to contend be on the alert to make improvement.

We believe the operating department should be represented on the board of judges, for they are better qualified to judge of the practical value of an outfit.

This contest should impress on all the necessity of some organization to which competent miners should belong, such

as the First-Aid Corps of the Red Cross, and every member should endeavor to make his membership of as much value and honor in this country as is membership in St. John's or St. Ambrose's abroad.

J. C. STONE, M. D.

Chandler, Colo.

Grades for Rope Hauls

Editor Mines and Minerals:

SIR:—I would like to hear through your columns, the experiences of other mining men with grips or clutches for endless-rope car hauls. I cannot find any information on this subject in my files of MINES AND MINERALS. What is the steepest grade on which endless-rope hauls have worked successfully with grips for attaching the cars to the ropes?

H. L. HANDLEY, Engineer



New Firedamp Detector

In a recent report by Consul General John P. Bray, of Sydney, Australia, is described a new device for detecting firedamp in mines that has recently been invented by two young chemists, junior teachers in the Technical College in that city.

The new detector is a simple and portable bit of apparatus, designed for the purpose of detecting and indicating the presence of firedamp and other dangerous gases in coal and other mines. Its warning is given either by a loud-sounding alarm bell, or by the flashing into view of a red-glow light. The makers of this simple contrivance have based their procedure upon Graham's law of the diffusion of gases, viz.: "all gases tend to diffuse into one another at a definite rate, which varies in an inverse ratio to the square root of the density of the gases." Taking also Ansell's firedamp detector as an additional starting point, the inventors have succeeded in procuring an efficient instrument which an inspector or miner may carry in his hand and test with ease and certainty the air in any heading or at any working face.

The apparatus consists of merely a piece of glass tubing bent into U shape, with the lower curve flattened. One leg of the U has an ordinary "shell" funnel at its upper end, and the open mouth of this is covered by a thin disk *a* of plaster of Paris, mixed thin, so that in drying it remains porous. The other leg is crowned by a small reservoir containing additional mercury, with a little glass tap *b* to allow the metal to be run into the bent tube when required.

Through each lower leg there is passed a fine platinum wire *c*, that of the funnel-crowned one being about half an inch below the level of the other, and immersed in mercury, which fills the bend of the U up to this level. Each wire is connected to the poles of an ordinary battery cell, and thence effective connection is made with either alarm bell or colored light.

What happens when the detector is brought into the presence of a mixture of gas and air is simply this: The foreign gas permeates the plaster of Paris seal and depressed the mercury column in *d*. This naturally causes the mercury in the other leg *e* of the U to rise and its rise brings it into contact with the platinum wire just above it. This slight contact is sufficient to complete the circuit, and set either bell or danger light to work. So sensitive is the apparatus that, as shown by tests during the recent exhibition, it can be adjusted to give warning of the presence of such a small proportion as 2 per cent., or even less, of an undesirable gas.

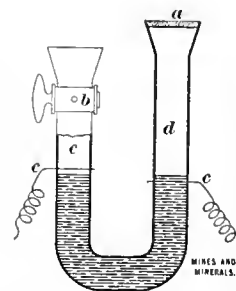

NEW FIREDAMP DETECTOR

Compensation For Mine Workers

Experience With Liability and Compensation Laws in Europe.
Features of a Desirable Law

By John H. Jones*

The following paper was presented at the session of the American Mining Congress, in Chicago, on October 25, by John H. Jones, president of the Pittsburg-Buffalo Coal Co., of Pittsburg, Pa. Mr. Jones has been intimately associated with coal mining and mine workers all his life, so that no one is better qualified to speak on "Workmen's Compensation Applied to Mining." What Mr. Jones has to say is drawn from his experience with liability insurance and the faithful study of "workmen's compensation" in all its many phases. The paper is therefore worthy of the attention of all those engaged in coal and metal mining, for as one delegate said "the subject will not down" until some satisfactory solution is obtained—EDITOR.

In presenting the result of the labors of the special committee appointed to consider and report upon the subject of a workmen's compensation act, I desire to call to your attention some of the things which form the basis of the reasoning of your committee.

The subject of employers' liability and workmen's compensation, in one form or another, has agitated the minds of men for years. The justice of some compensation is generally conceded, and American industry is seeking the best plan to accomplish this object.

The coal-mining industry is no stranger to either "liability" or "compensation," nor did it wait for law to compel, demand, or suggest, a reasonable care for those injured in the mines.

It is natural, then, that a subject of so vital importance to the industry should engage the serious attention of the Mining Congress.

Before deciding on a serious matter of this kind, let us examine what has been done in England, and what has been done in Germany along similar lines.

Mr. A. H. Gill, M. P., of Balton, England, and secretary of the Operative Cotton Spinners Association says:

"In England, before the 80's, the common law was the only means of adjustment, and when negligence of the employer was not proven it was hard to get compensation. The work people became dissatisfied with this state of affairs and began to agitate for a new law, and, as the result, an Employers' Liability Act was passed in 1880, and while it was an improvement on the common law, the act was not a success, as it embodied the doctrine that an employer should not be liable unless negligence was proved. It has always been difficult to succeed in an action under the act, as so many means could be found of resisting a claim. The result of the failure to secure compensation caused a further agitation for an improved method of dealing with the problem, which bore fruit, for in 1897 an act was passed, known as the Workmen's Compensation Act. This act did away with the doctrine of contributory negligence and made the employer liable to pay compensation to a workman who lost time through any accident which occurred while following his employment."

It is unnecessary to discuss this act further than to say that it required 26 years of agitation by workmen, and 26 years of study and experiment by practical men, before a Workmen's Compensation Act was passed.

The opinion of Samuel Gompers, dated Washington, D. C., December 24, 1910, was that

"The Illinois legislature should enact a liberal employers' liability act at the special session and then undertake an investigation with a view to the introduction of an automatic compensation law, for that view observers now regard as the most

feasible and just solution of the vocational ills, accidents, and deaths."

Six employer members of the committee of twelve, Illinois Employers' Liability Commission, reported as follows:

"In spite of the fact that every one of the industrial nations of Europe has discarded the system of paying damages on the ground of the liability of the employer, and has adopted in its stead the payment of compensation for industrial accidents; in spite of the fact that New York has adopted a Workmen's Compensation Act, and that both Wisconsin and Minnesota are considering compensation as the only feasible solution to this problem, the Chicago Federation of Labor and its representatives on the Commission have taken a decided stand that the abrogation of the employers' defenses must precede any bill providing compensation.

"It is evident from the letter which the Federation submits that its officers not only are unfamiliar or unmindful of the economic waste involved in any employers' liability system, but that they have no knowledge of the total inadequacy of such a system, even when extended by such serious modification of the employers' defenses as the American Federation of Labor advocates.

"An employers' liability law meets none of the prime necessities of definite compensation, immediately and automatically paid. Under it every case is a gamble."

Major A. R. Piorkowski, representing the Frederick Krupp Co., of Essen, Germany, speaks for the German system as follows:

"The German Accident Insurance had its precursor in the Liability Law of 1871, by which the operators of industrial establishments were liable for the accidents caused by them. The injured workmen had to bring proof that the operator caused the accident, and the amount of compensation was determined by private societies. It is evident that such an arrangement could satisfy nobody. The consequences were long drawn out and costly law suits, by which the contrasting interests of employers and employe were glaringly brought to light.

"The more law suits between both classes, the more hatred was engendered and the farther apart they drifted in their mutual interests. Employers, employes, and the government looked eagerly for a better solution of the problem. The Germans finally determined the liability law did not work for peace between capital and labor, because it worked unjustly toward both of them. Therefore, the only logical and just way to compensate for the injuries done was by insurance.

"First, the proposed compulsory insurance, through an imperial financial institute, that contributors should be employers and the insured. The Reichstag refused this plan.

"Then the Central Association of German Industries recommended the accident insurance. The place of an imperial insurance was taken by the trade associations of the employers. Instead of contributions by the employers and communities came the burden of the first thirteen weeks to be borne by the sick funds, to which the workmen had to pay nearly 67 per cent. The administration remained with the employers. The arbitration courts consisted of employers and employes in equal numbers.

"In 1900 this law received its present shape—briefly. All workmen and administrative officers—the latter provided their annual earnings do not exceed 3,000 marks—are insured against the results of accidents in the course of their employment, if employed in mines, factories, and similar establishments specified in law. In case of disability, compensation is rendered from the beginning of the 14th week after the date of the accident.

"The injured person received free medical treatment, medicine, and other means of healing."

If any gentleman present imagines that the German system would be a success in this country, let me quote from *The New York Commercial*, of Friday, October 20, 1911, under the heading, "Liability Men Criticize State Insurance System." After

*Chairman of the Committee on Workmen's Compensation.

much more than an attack upon the suggestion of Governor Wolfe to state accident insurance, it reads:

The speaker alluded to a recent review of the imperial insurance system, written by Dr. Ferdinand Friedensburg, who has recently retired after 20 years at the head of the senate of the imperial insurance office of the German Empire. Doctor Friedensburg does not find the German system, as it has worked out in practice, by any means ideal. He does not condemn the principles underlying the workmen's compensation for accidents.

Doctor Lott quoted him as saying that charity crept in and corrupted the system at the beginning; that workmen very soon got accustomed to bringing their complaints, doubts and claims of any nature whatever to the imperial insurance office, often without appealing to any intermediate instance; that the imperial insurance office, which is intended to handle questions of law, is overburdened with frivolous and unfounded claims; that 'the expenses of the system continued to grow as the force required increased'; that 'the number of officials in the imperial insurance office has multiplied in tune with the ever-waxing burden of work'; that 'the number of accidents grows with monstrous speed'; that 'in 1886, 100,159 accidents were reported and 10,540 (10 per cent.), compensated; in 1908, 662,321 accidents were reported and 142,965 (21 per cent.), compensated'; that 'often an accident is sought for and arranged'; that sometimes a chronically sick man swears that his old illness is the result of a recent accident and gets consequential help; that 'the communal chiefs act entirely under the belief that they ought to help their local residents, as a result of the common opinion that the insurance funds have more money than they know what to do with, and this idea strikingly deadens the conception of legality and love for the truth'; that naturally the universal laxity, the payment of unjustified claims, and the extravagance practiced justified claims, and the extravagance in equipping hospitals and sanatoria impair the integrity of insurance funds'; that 'employers do all that is possible to escape their burdens, which they feel to be unjust and in vain as enormous sums are annually exacted from them in fines,' that 'industrial unions and insurance institutions have been repeatedly on the brink of bankruptcy.'

"Doctor Friedensburg points out that the excessive cost of the insurance system, which is one result of the degradation of the system into charity, is complained of by employers, and that state insurance therefore, reacts injuriously upon Germany's industry."

He says: "As a result of the costs of insurance which have gradually become monstrous, German industry is put at a disadvantage and is hampered to the extreme in its competition with foreigners."

In deed, Doctor Friedensburg makes the astonishing statement that the German system of workmen's compensation is held responsible for the marked rise in prices which is felt to be oppressive by all classes of the German population.

Mr. Wolfe is of the opinion that whether the state will undertake the employers' liability business to the exclusion of the companies depends upon the attitude of those companies and their disposition to cooperate with the state in the solution of the economic problem. He said that employers' liability insurance represent more than one-half of the entire liability business transacted and consequently the question of state insurance is of vital interest to the underwriter.

While heretofore the question may have seemed to the underwriters a fact or a form of socialistic doctrine and an interference with the right of contract, a discourager of thrift and an encourager of malingering and intentional accidents, public opinion is overwhelmingly in favor of entering the cost of human accidents as a part of the cost of production, and the underwriters, in the opinion of the speaker, must face the situation accordingly. Mr. Wolfe believes that a desirable law should embody the following features:

First. A statement of the circumstances under which the employer becomes responsible for an accident during the hours of employment.

Second. A definite scale of benefits to be paid by the employer when he is responsible.

Third. A requirement that every employer to whom the law applies shall file with the commission, mentioned hereafter, satisfactory evidence that his responsibility for the payment of benefits for which he becomes responsible is guaranteed by a corporation authorized to transact the business of liability insurance.

Fourth. The appointment of a commission (some of the members of which should have a knowledge of the technical side of employers' liability insurance), which would classify risks, and would, after the necessary investigation, fix the minimum and the maximum rate which would be charged any corporation authorized to furnish the guarantees.

Fifth. A provision that the commission may, after hearing evidence, order the installation of proper safety devices in order that accidents may be prevented as far as possible.

Sixth. A provision that those employers having more than a certain number of employes may, instead of becoming insured in a private company, elect to deposit with the state the minimum premium required by the commission, which deposit is to be increased from time to time as required by the commission, in order to cover the present values of benefits to be paid, and is to be withdrawn on filing with the commission satisfactory evidence that the deposit is not required for the payment of claims.

Mr. Rowe stated that obviously the trouble with state insurance, viewed from an impartial angle would be the mixing of politics with it. "Workmen's compensation insurance," he said, "can only exert its effect as a blessing if free from all exaggeration and particularly from the conscious or unconscious love-making with the 'lower classes.'"

"Such insurance," he said, "must be issued by an independent institution free from all partiality."

Employers and employes should not lose sight of the fact that less than 50 per cent. of the premiums paid, goes to the real beneficiaries. Whether or not this may be considered economic waste is for others to judge.

Here then are introduced two methods, one the "Employers' Liability Act," which has been discarded by practical men, the other the "Workmen's Compensation Act," now before us, and between these two we are called upon to choose.

Your committee urges a Workmen's Compensation Act as best fitted, by experience and practice, to the mining industry.

The Liability Act appears, to your committee, to be unjust and unreasonable, in principle and practice—the very mention of it suggests lawyers, courts, delays, annoyances, strained relations, expense to employers, and loss to workmen. In one word it means "fight." The Compensation Act means "Payment." The former is an unknown quantity, the latter is a fixed principle known and computed in advance, and provided for. The record of the Liability Act is said to be about 50 per cent. adjustment—the Compensation Act means 100 per cent. adjustment.

Adjustment under a liability act is reported, by one large coal operator, to be injurious in 80 per cent. of cases in a large disaster, in that it would shower money into the hands of the inexperienced, where value is unknown, and where money and widows are soon parted. That this is no idle dream is no doubt known to every man here, and the speaker has had enough experience to "fill a book"—just one experience will suffice to illustrate. During the past two years a certain widow, of a miner, received a so-called liability adjustment, two of the first purchases made were a gold watch and a silk dress, which added to other things made the expenditure for the first month \$900. She spent over \$3,000 a year for these two years, and now finds herself and five children objects of charity. Surely

it cannot be urged that this is the compensation intended. True, it was her inexperience and failure to value money that worked the mischief. This is the very thing we argue. This woman is a fair type of those with whom the mining industry has to deal, and the illustration is from life and by no means an isolated case.

Under the Compensation Act no such temptation would have presented itself—the adjustment would have simply continued the natural earning and pay conditions for a period of years, insured the woman against her own inexperience and extravagance, insured to the children the real object of the Act, and be a blessing to the family, and to the community.

Liability law adjustment, in the judgment of the committee, is a mistake—is uncertain and unreasonable—is an injustice to all concerned, and is prejudicial to all the best interests of a miner's widow and children—that it defeats a good intention, and does not insure the care, education, and opportunities of life, supposedly vouchsafed, to the husband and father, by a law which caused him to risk and lose his life in an honest belief, and a sincere endeavor, to provide for his family. In short, it looks as though the most ardent supporters of an Employers' Liability Law, are ambulance chasers, and those who could hope to profit by a disturbed condition, as between capital and labor.

It is also conceded that labor is just as necessary for the maintenance of industry as any other commodity, and that the cost of compensation, as a fixed principle of industry, should be reckoned with in placing a price upon the finished product. Upon the grounds stated, we believe the liability act to be wrong in principle and practice, and that the injustice of it falls upon those who are least able to bear it, on the one hand, and, upon the other hand, this injustice would fall upon those who are supposed to be wealthy—which supposition is based upon opinion thoroughly unfamiliar with the facts, and therefore incompetent, an opinion of those who do not stop to consider whether or not the cost of their wishes is within the possibilities of the industry, or to take into consideration the fact that not one out of ten coal companies could stand the cost of some of the disasters, which have occurred during the past few years, under a liability act, or the further fact that less than 10 per cent. of the coal companies have as much money invested as the cost of some of the mine disasters, of the past three years, and that a liability act would bankrupt 90 per cent. of the companies, should this class of disaster visit their mines—surely such a law would endanger the industry, and therefore cannot be the sober judgment, or even the sincere desire, of either workmen or employer.

The mining industry should stand ready to bear the burden of its own accidents—it should stand ready to pay a tax of 1 cent per ton of coal mined to meet the necessities of the case and to provide the necessary funds.

It should stand ready to have this fund administered wisely in the interests of the workmen and their families.

It has always stood ready to consider, and has introduced every known precaution to prevent these accidents and to safeguard every man employed above or below the ground.

It considers all this right, reasonable, and just, and that the best direction to move in, to accomplish the best results, is the passing of the Workmen's Compensation Act.

This consideration of the subject is not based upon selfish or narrow motives. The company I have the honor to represent operates in five states—the cost, to our company, under this proposed act, which it approves, will mean \$50,000 to \$60,000 a year, and it is only one of many companies, all of which goes to show that the industry is actuated wholly by humane motives, and a sincere desire to squarely meet the conditions of the times, therefore the honesty of the mining industry's view of the matter must be self-evident to every right thinking man.

In the preceding argument we have referred to the best direction to move in to accomplish the best results, and have clearly stated our reasons in favor of the Compensation Act.

There is another important matter to consider in connection with this proposed act, namely—the mining industry must give its best thoughts to the method of introducing and passing the Act—it cannot be left to the unfamiliar majority. The combined cooperative influence and wisdom of this Congress is vitally necessary to guide public opinion and legislators in this important matter. The necessity for reasonably uniform legislation by the different states of the Union must not be lost sight of. Uniformity of legislation on all subjects of common interest is one of the most important questions of the times. It was the Hon. Seth Low, president of the National Civic Federation, speaking upon this question, who said:

"If one industrial state makes a change in the law of master and servant, or of negligence, it may unwittingly greatly endanger its manufacturing industries, but if the competitive industrial states will move correspondingly along the same lines, no one of them is likely to be endangered, and the whole country may be benefited."

And, along the same lines, it was Senator Root who said:

"The time has come when each state must legislate on matters of common interest from the point of view of one of a family of states, rather than from the point of view of an individualism that is self-sufficient—the people of the country have grown together in so many ways, without regard to state lines, that, unless fairly uniform legislation can be had upon a constantly increasing number of subjects, the demand for action by the central government is likely to become irresistible, and, in time, even to require an amendment of the Constitution of the United States to give to the central government the power the states fail to use for the common benefit."

It is to bring about just this uniformity that we recommend to this Congress the appointment of a general committee, and we might go a little farther than the printed recommendation and have this committee consist of one man from each of the several states, this general committee to have charge of the enactment of the law presented by the committee, each appointee to act as chairman of a committee of five within his state, composed of himself and four others members, charged with the duty and responsibility of seeing to it that the state legislatures of these states shall pass this law.

The necessity for careful study, for the wisdom which comes from the multitude of counsel, and for definite and determined action, is clearly evident.

The American mining industry should here go on record as favorable to that solution of this problem which is right, reasonable, and just to the industry, to the employer, and to the employee.

A law that strikes at the life of the industry will be a calamity.

A law that does justice to employer and employe, that operates, and compensates, without delay, friction or loss, will be a blessing. May the "wisdom which cometh from above" lead and guide us into that which is best.



Jet Making in England

Whitby, on the North Sea coast, in Leeds district, England, has been the home of the jet industry of England. Jet, a species of lignite, is still mined at Leeds and made up into ornaments for personal wear, but only to a limited extent. Fifty years ago it was a flourishing industry, giving direct employment to 1,500 people in Whitby; now not over 30 are engaged in its production, generally old people, and no others are taking it up. The price of rough jet has fallen in that time from 25 cents an ounce to from 75 cents to \$2.90 per pound.

One old Whitby worker now plies his trade in Leeds and exposes his wares for sale at the city market twice a week. He is the only one so engaged in this city. Some Spanish jet, which is harder and more brittle than the English variety, is imported into England. Fashion has decreed the disappearance of this once important industry of Whitby.

An English Colliery Electrical Equipment

A Description of the Power Generating Plant, Tipple, and Hoisting Cage at Clock Face Colliery

In order that Americans may see what their friends across the Atlantic are doing in the way of colliery equipment the following description by a special correspondent will be found well worth reading. Like the Americans, the English, when installing new surface plants at coal mines, pay particular attention to electric appliances with a view to efficiency and economy in working. [EDITOR.]

The construction work of the Clock Face colliery of the Wigan Coal and Iron Co. was begun in 1905 and in the latter part of 1906 it was so far advanced that coal shipments were started, although underground development is still being pushed to the property lines.

Clock Face colliery is 3 miles from St. Helens, in Lancaster County, England, and is a modern plant in every way, no expense having been spared to insure the maximum economy and efficiency in producing, preparing, and loading the coal for shipment.

Following British and Continental custom in the matter of shaft form, two 20-foot diameter circular shafts were sunk 2,400 feet to reach the coal bed. These two shafts are connected with the mine workings in such a way that one acts as an intake for fresh air and the other as an upcast for the air that has become vitiated in traveling through the mine workings. Connected with the up-cast is a 22-foot diameter engine-driven exhaust fan for creating artificial ventilation in the mine. In order that a check may be kept on the speed of the fan and consequent volume of air passing through the mine, the revolutions are registered by a counter and also by an ordinary tachometer. The British Westinghouse Co. installed the electric power plant, which is up to date in every particular, as an examination of the illustrations accompanying this article shows.

Steam for driving the machinery is generated in a battery of ten Lancashire boilers to a gauge pressure of 110 pounds per square inch. The feedwater for boilers is preheated by the exhaust steam in feedwater heaters to 180° F. before being pumped into the boilers.

Electric energy is supplied by the plant shown in Fig. 1, which consists of two 400-kilowatt, Westinghouse-Parsons, straight-flow turbines running on live steam

of 100 pounds gauge pressure and superheated 200 degrees. These are coupled to turboalternators generating three-phase, 50-cycle current, at a pressure of 2,200 volts, the speed being 3,000 revolutions per minute.

Attention is directed to the substantial brick power house and the overhead crane that may be put in commission any time that parts of machinery are to be lifted for repairs, or new machinery installed. Although not shown, there is in connection with the power plant a Westinghouse-Le Blanc condenser and air pump capable of condensing the exhaust steam from the turbines and maintaining a vacuum of 28 inches when carrying a full load. The air pump in connection with the condenser is driven by a 15-horsepower squirrel-cage motor running at 845 revolutions per minute.

To the rear of the turbogenerators is a switchboard for controlling the power from these units; it consists of five panels of black enameled slate. The panels are separated at the back by slate partitions, and the spaces formed by these panels are enclosed by expanded metal doors. The current bus-bars are carried overhead by porcelain insulators. Of the five panels, two are for the turbo sets; two for outgoing feeders, one of which controls the underground load, and the other, the surface load;

while the fifth panel is provided with bus-bars, and isolating plugs for the possible extension of the plant.

The current is led to a 500-kilowatt, 2,200 to 500 volt, three-phase, 50-cycle transformer placed in the basement, and is taken out through the wall by two triple-conductor insulated cables, supported on wooden poles for about 40 yards, and thence by the wall of the hoisting engine house to the shaft mouth, where one cable goes under-

ground, and the other to the coal screens in the tipple.

A motor-generator set shown in Fig. 2 is used for converting the alternating current to direct current for surface lighting. The cables for this current run on the same poles as those mentioned for carrying the alternating-current cables. The set comprises a 250-volt, 37.5-kilowatt, direct-current generator, direct coupled to a 60-horsepower, three-phase, 720 revolutions per minute, 500-volt squirrel-cage motor.

An oil-immersed auto starter is provided for starting the set.

There is in addition to the turbo-generators an engine-driven direct-current generator which supplies power for lighting at night and for driving the tipple machinery. Two motors for this work are shown at *a* and *b* in Fig. 3. The motor *a* drives the shaking screens *c* and the rotary tipples *d* by means of belts,

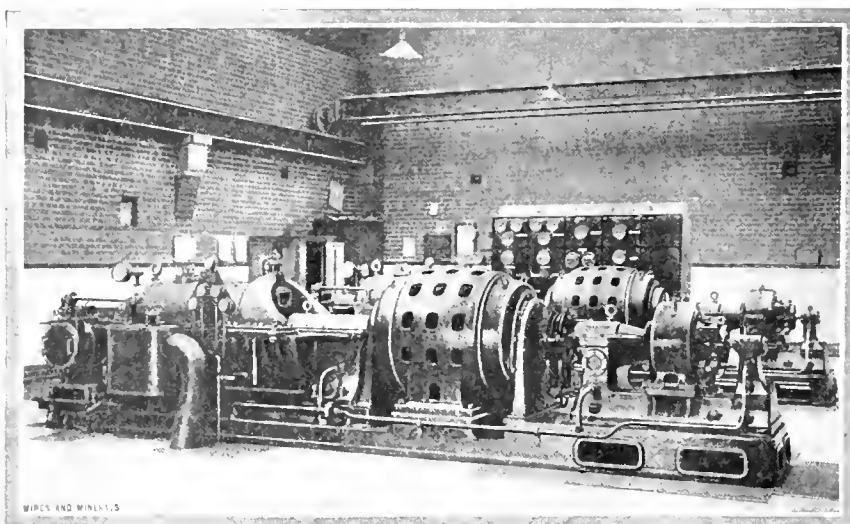

FIG. 1. STEAM TURBINE GENERATORS AT CLOCK FACE COLLIERY

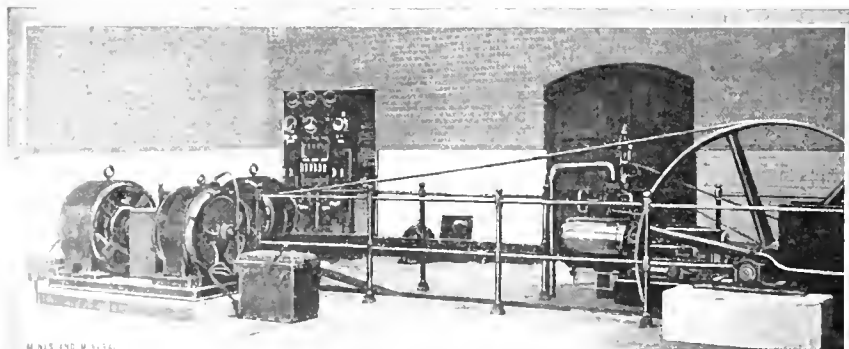

FIG. 2. MOTOR-GENERATOR SET AT CLOCK FACE COLLIERY

while the motor *b* operates the picking belts, the lowering ends of which are operated from a countershaft driven by the same motor. One 10-horsepower motor drives an empty-car chain haul, while a similar motor drives a trip feeder that delivers the loaded cars *c* to the rotary dumping cages. The latter motors are placed below the tippie floor, and because of the dusty conditions that prevail and to prevent accidents the belting is housed as shown in Fig. 4. An examination of this illustration will show that every precaution is taken to guard against accidents and fire; even a box of rubber gloves being supplied for those who have charge of the electric machinery.

An interesting feature in connection with the tippie, and one which would be against the mine law of Great Britain were the tippie not fireproof, is that the screening plant is directly over and 29 feet above the hoisting shaft, so that the cages are wound up into the head-house. This necessitates head-gear somewhat more massive and extensive than is usually required for this work, but a great deal of time and labor is saved by this arrangement as it obviates manual labor in connection with running loaded cars on the rotary dumping cages and in pushing the empty cars back to the cage. Further, the coal is automatically tipped into the screens, conveyed on belts and delivered into the railroad cars in one continuous operation. When one considers the great quantities of shafting, gearing, and belting that would be required to perform the same work where similar machinery is steam driven the advantages of motor-driven machinery are evident.

Double-decked hoisting cages are used at the Clock Face colliery, four mine cars being carried on each deck. The total coal hoisted on one cage at one time approximates 4 tons.

To the American this seems a weak point in English colliery practice because it is evidently cheaper to hoist two 2-ton cars than eight ½-ton cars, and it is also cheaper to hoist one 4-ton car than two 2-ton cars. The conditions relative to thickness of the coal beds necessarily regulate the size of the cars; nevertheless in the United States the output from coal beds 30 inches thick and sometimes less will approximate 2,000 to 2,500 tons in 8 hours where cars holding 1 ton of coal are hoisted from depths between 700 and 900 feet. In the United States capacity is obtained by making the cars long and wide, while the English cars or tubs are made narrow and as high as the thickness of the thin bed will permit. It would appear to the American engineer not conversant with all the conditions surrounding

The whole electric installation is working in a very efficient manner, is kept in excellent condition, and has given great satisfaction to the proprietors.

Aprpos to this output, several shafts in Illinois have been or are equipped to raise from 3,000 to 4,000 tons per day. Recently on single-platform cages, carrying two 2-ton mine cars

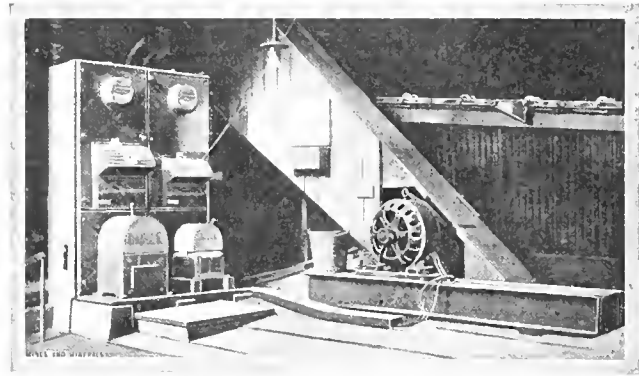

FIG. 4. PROTECTION OF MACHINERY AT CLOCK FACE COLLIERY

there were raised 4,260 tons of coal from a depth of 285 feet. This was a record for this mine as its usual output in 8 hours is 4,000 tons.

來 來

Dropping-In Arrangement

It is a prevailing idea among mining engineers that when once the loaded trip has left the mine it should under no circumstances be allowed to enter again. By reason of this belief, not infrequently excessive charges are incurred in cutting away hillsides or in building trestles, even in poorly locating the railroad tracks, that the loads may be properly dropped into the tippie. That this expense for outside work may, at times, be unnecessary is shown in the accompanying sketch of the arrangement at the Cameron mine, of the C. F. & I. Co., at Walsenburg, Colo. The slope could not well have been placed elsewhere and the location of the loading tracks and consequently of the tippie is fixed by the topography. Also between the outcrop of the seam and the edge of the bank the distance will not average more than 20 feet.

In order to secure landing room, instead of cutting away the steep hillside

above the outcrop, which at best would have resulted in sharp curves in the tracks requiring the labor of two or three men to push the loaded trip around them, a curved tunnel *ab* is driven in the coal. The loaded cars are brought up the slope to daylight by the electric

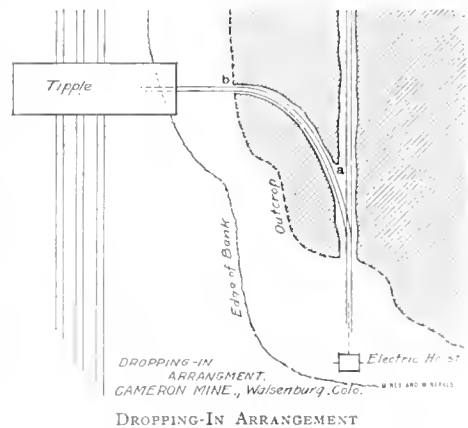

hoist situated directly in line with the slope mouth as shown in the accompanying sketch, and the trip rider having set the switch, they are dropped out through the curved tunnel *ab*. As the grade in this drift is heavy, the trip runs out properly and, there being no curves at the tippie, the cars are easily handled and the labor of several men is saved.

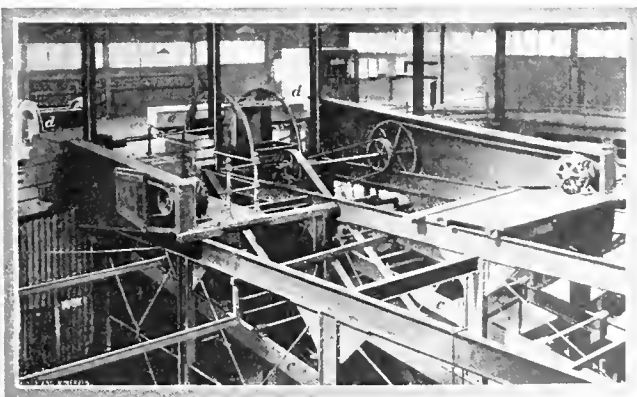

FIG. 3. MOTORS DRIVING TIPPIE MACHINERY

English coal mining, that if the small "tubs" are to be used inside the mines they should be dumped into a larger car before the coal is raised up the shaft.

At the present time the Clock Face colliery is being opened out, but when the underground developments are completed it is expected that the output of the plant will be at least 1,500 tons per day.

Buckner No. 2 Mine of United Coal Co.

The seam known as the No. 7 seam, in Williamson county, Ill., is attracting a good deal of attention because the quality of the coal is said to be the best of running so low as 10.4 in moisture, 7.22 in ash, 887 British thermal units, when wet, but when dry, the figures range 8.10 in ash and as high as 13,325 in British thermal units. The Williamson and Franklin counties coal field is considered the most important in the state, as here the coal seam averages 9 feet in thickness, with sometimes a good roof and again with a roof shale that requires a portion of the seam to be left for its support. For the production of prepared fuels a large portion of the fine coal is washed and graded into five sizes. In some instances there is no effort put forth to restrict the quantity of fine coal made, because it is desirable to produce the prepared sizes for market. Not all of the fine coal is washed, there being a percentage of high-grade raw screenings shipped. The quality of the coal is better than that from the No. 6 seam, which fact overcomes the difference in freight rate.

At present there is considerable coal property changing hands and new operations being started. The United Coal Mining Co., which has probably the largest and most modern plant in Illinois, commenced sinking their No. 2 mine, near Buckner, in the fall of 1910. Coal was reached in May, 1911, and its development was immediately begun through the escape-ment shaft while the main shaft was being fireproofed. The main shaft is 11 ft. \times 19 ft. in the clear and 447 feet deep. The escape-ment shaft is 16 ft. 3 in. \times 11 ft. 3 in., with a compartment for a stairway. According to a recent Illinois law it is necessary for main shafts to be of fireproof construction but the law does not state what this construction shall be. The main shaft of the United Coal Co. is concreted from the surface to a depth of 25 feet, and from the bottom upward 25 feet, the space between being timbered and covered with non-expanded metal plastered over with fireproof material about 1½ inches thick. The top equipment which was installed by the Roberts & Schaefer Co., Chicago, is of modern design and complete in almost every detail.

The hoisting engines are of the Danville patent, 28 in. \times 48 in., with steam brake and steam reverse. The hoisting drums, two in number, are 9 feet in diameter. The electrical equipment consists of one generator, 250 kilowatts, 275 volts, direct-connected to a four-valve engine, 20 in. \times 24 in.; one dynamo, 50 kilowatts, 250 volts; a six-panel switchboard of black Monson slate, with one panel for the 50-kilowatt generator, and one panel for the 250-kilowatt generator, besides one panel reserved for future extensions of the electric-power plant. There

is another panel with switches for distribution of the current to the mine with the necessary ammeters, circuit breakers, and recording watt meter. There is also another panel with eight switches and ammeter to distribute current to the different buildings on the surface, and still another with four gauges, one of which is a recording gauge with a clock.

On the wall beside the switchboard is a damper regulator which automatically regulates the strength of the draft and the speed of the stoker engine as the steam pressure rises or falls. For the purpose of easily and speedily handling the heavy parts of the machinery, there is an I beam equipped with tackle blocks and arranged to run the entire length of the engine house. To the south of the engine house is a 30,000-gallon steel water tank to which water is pumped from a pond, 1,500 feet distant, by a centrifugal pump, driven by a 20-horsepower motor. The pump is automatically operated by a switch on the tank which sets the motor in motion or stops it.

Another item of interest is a triplex pump, automatically regulated, which will pump water from the mine to the surface. From the main steam line in the boiler house, shown in Fig. 1, a 7-inch steam line supported on concrete piers runs to the fan engine. To this steam line is connected a horizontal tubular boiler in such a manner that in case a shut-down of the large boiler plant is necessary, steam from this boiler will operate the fan and the 50-kilowatt unit, also a small engine at the escape-ment shaft. This latter engine is used for lowering materials into the mine and can also be used in case of emergency to hoist men.

The ventilating fan is 16 ft. \times 8 ft., and is connected to a four-valve engine, 18 in. \times 24 in., with a hand cut-off. The mine plant buildings are all of red brick and all have red tile roofs. There are four water-tube boilers of 350 horsepower each, which are fed by automatic stokers. Coal is carried to the stokers by a scraper conveyer equipped with automatic weighing scales to weigh the coal as it is used. The ashes are run automatically from the stoker to a tunnel underneath the boilers, where they are pulled out by a friction hoist. The boiler water is pumped through feedwater heaters by twin pumps having automatic governor to regulate the quantity of feedwater. There are steam separators to every engine which separate the water from the steam, thus permitting the engine to use comparatively dry steam.

The tippie has four tracks and is supported on concrete pillars, with a shaker-screen structure of massive construction provided with screens for separating the coal into about nine different sizes. Underground, coal is to be cut with electric machines and gathered and hauled to the shaft with motors. The pit cars have a capacity of 4 tons and the ultimate output from this mine will be about 4,000 tons in 8 hours.

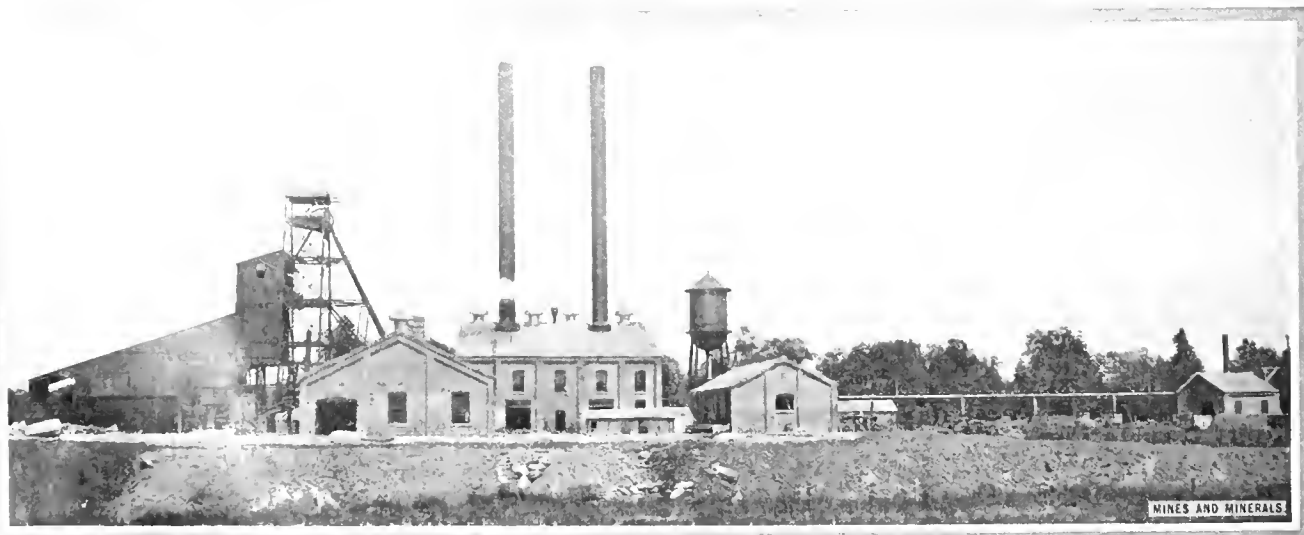

FIG. 1. BUCKNER NO. 2 MINE TIPLE AND POWER PLANT

The Weathering of Coal Seams

Peculiar Geological Conditions at Mines of Charley Coal Mines Proprietary, Ltd., Queensland

By Tom Coventry*

The Tropic of Capricorn bisects the Dawson-Mackenzie coal field, and the Queensland, Australia, Central Railway undulates from the port of Rockhampton along the tropic westerly. So far as is now known the coal trends about 200 miles north-northwest from the railway and about 200 miles south-southeast, whilst the eastern edge is near the 78-mile peg of the railway, and the westerly extension is to the 120-mile peg. Thus, the coal field has an area of 16,800 square miles. But the whole area is not productive, the anticlinal folds being non-productive. The synclines, however, are large and contain many workable seams of coal from 4 feet to 18 feet thick. Although the Dawson-Mackenzie coal measures are not folded and contorted to such a degree as the anthracite measures of Pennsylvania, yet the two fields, so far apart, are strikingly alike geologically. And this likeness is emphasized by the fact that just as Pennsylvania possesses a great bituminous coal field to the westward, so the Dawson-Mackenzie semi-anthracites are flanked to the westward by a bituminous coal field having seams of clean coal, without a band, 40 feet, 50 feet, and up to 63 feet in thickness. These are flat seams.

"A Section of the Coal Measures Half a Mile West of Trevorton Gap, Pa.," by H. D. Rogers, is a close analogy with the section of coal measures comprising the Charley syncline at the 78-mile peg, Queensland Central Railway. No other coal field in Australasia has a cleavage system, but on the Dawson-Mackenzie the cleavage is well marked and a particular feature in the Charley syncline. The monograph by the American geological observer, Campbell, on the expulsion of volatile matter along the cleavage joints of coal measures, having a cleavage system, to account for the alteration of a bituminous coal to a semianthracite or anthracite, well applies here.

Paleontological Evidences.—The Newcastle coal measures of New South Wales, Australia, form a great basin, and the top seam (Bulli), to which the Balmain shafts are sunk, underlies Sydney harbor at a vertical depth of 3,000 feet. These measures are not folded nor contorted, nor is there any cleavage. The Dawson-Mackenzie coal measures are more or less folded and mildly contorted, and have a distinct cleavage. The whole

of the coal seams in the Newcastle basin are bituminous, whilst the whole of the coal seams on the Dawson-Mackenzie are semi-bituminous or anthracitic. Yet the paleontological evidence tends to prove that the two coal fields are of the same age. The fossil flora obtained from a shaft and cross-cuts in the Charley syncline were determined by Robert Etheridge, curator, Australian Museum, Sydney, and at his request W. S. Dun, paleontologist to the New South Wales Geological Survey, made notes on the range of the genera, or species, in the Newcastle coal measures. Table 1 shows the list of plants and notes thereon.

In connection with Mr. Dun's discovery that in the Balmain coal mine, at a depth of 3,000 feet, there is a mingling of botanical fossils of two different geological periods, it will be noted from the foregoing list that the same thing occurs in the

Charley coal mines—that evidence has been found of the distinct passage of the fossil plants characteristic of the Permian-carboniferous coal measures of Australia upwards in the plants which are typical of the Triassic age.

Professor David, of the Sydney University, regards Mr. Dun's discovery as of great scientific interest, and is of opinion that the survival of the fern, *Glossopteris*, in Triassic time may have been connected with the situation of Balmain near to the center of the great Newcastle coal basin. He says: "Around the margin so far it appears that everywhere the *Glossopteris* flora was overpowered and replaced by the invading Triassic flora, the only portion of the old flora to escape being that situated in the heart of the old swamp at Balmain."

Such an explanation is of more than academic value, inasmuch as it seems to account for the coal measures of the Charley syncline being not less than 4,400 feet thick, whereas at the Queens-

land state coal mines, 50 miles southeast from the Charley mines, the Queensland government geologist has measured and estimated the thickness of the coal measures at that place to be 2,600 feet. Hence, if Professor David's explanation is applicable, the Charley syncline is probably the heart of the old Dawson-Mackenzie swamp.

Incidentally it may be stated that a railway is now under construction at an estimated cost of £456,000 to connect the Mount Morgan copper-gold mine with the said State coal mine.

The Solubility of Carbon.—We are taught by our most eminent chemists that carbon, or coal, is insoluble. Possibly no solvent for the element has yet been discovered; at all events, no solvent that would or could act within a reasonable time. Yet there must be a natural solvent. The whole of the fossil flora found in the Charley syncline below the zone of weathering

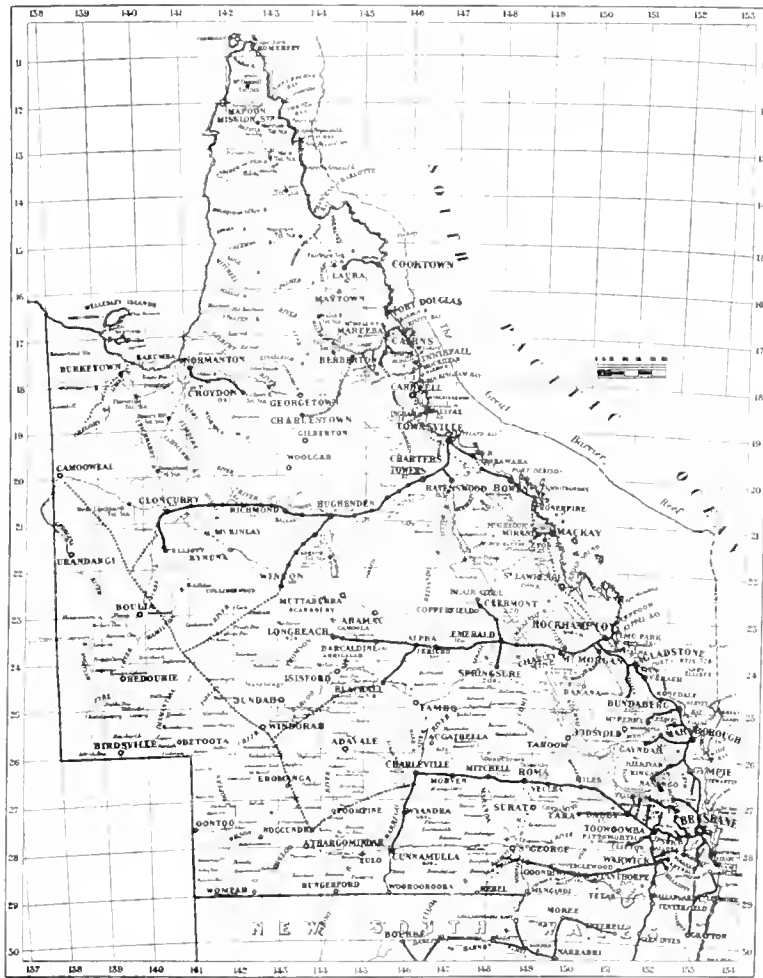

FIG. 1. MAP OF QUEENSLAND, AUSTRALIA

* Superintendent the Charley Coal Mines Proprietary, Ltd.

have... The fossil flora determined by Mr. R. Etheridge in the aforesaid list, were among the most

TABLE 1

Incline	Newcastle Coal Measures
<i>Pl. ...</i> (stem and leaves) <i>P. hookeri</i> , McCoy.....	Would appear to be more common in upper than lower coal measures.
<i>Glossopteris</i> (leaves).....	Gangamopteroid forms more common in both lower and upper, apparently.
<i>Sphenopteris flexuosa</i> , McCoy ..	In both lower and upper, but more in upper.
<i>Alethopteris australis</i> , Morris....	I have not seen this species at all but a form very close to <i>A. whitbiensis</i> = <i>A. Cladophledis Roylei</i> is abundant in Balmain Shaft with coal.
<i>Schizoneura</i> . ? <i>S. australis</i> , Eth. fls.....	Have not seen this yet with lower coal measures. In Balmain Shaft it occurs above the seam associated with <i>Glossopteris</i> . There appears to be no break stratigraphically between the Permian carboniferous and Narrabera.
<i>Phyllocladus</i> (Woods).....	Coniferous wood = <i>Dadoxylon</i> (araucarioxylon) occurs in both lower and upper coal measures.

perfect plants that gentleman had ever seen, the finest markings being distinct and definitely outlined. And all samples were

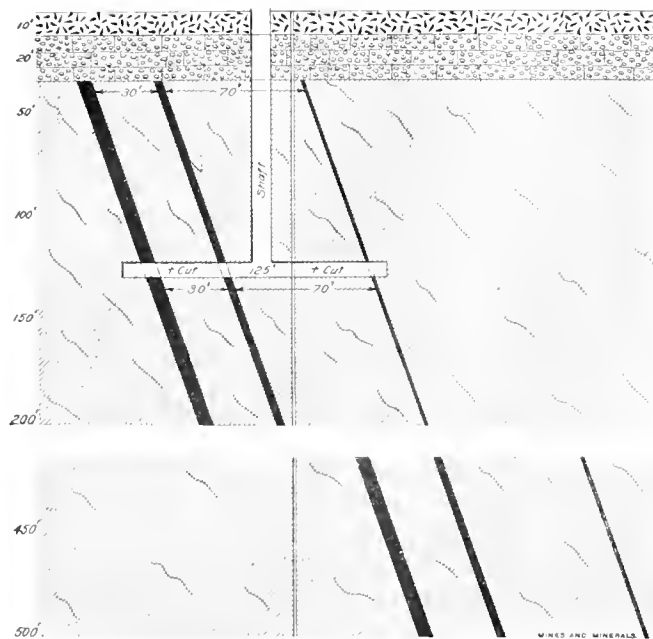

FIG. 2. SECTION AT CHARLEY COAL MINES

leached. Not a molecule of coal was traceable. Some pseudo-morphs were limned as bas reliefs by red oxide of iron, others in sky blue, and others in brown. They were all taken from cross-cuts at a vertical depth of 120 feet, where the whole of the coal measures were altered beyond recognition by weathering.

The Weathering of Coal Seams.—If there is any literature on the weathering of coal seams, I have not found it. Of course outcrop of coal may be expected to be dirty, some very dirty. But that a seam of coal could weather to a blue-pug plastic clay seemed impossible until one saw it, and proved it unquestionably. The section Fig. 2 shows a nest of three seams of coal, one 9 feet thick, one 7 feet thick, and one 4 feet thick, and all dipping southwest at an angle of 75 degrees. They are overlaid unconformably by horizontally bedded ferruginous conglomerate. At their junction with this conglomerate they are all distinct seams, but seams of blue-pug plastic clay in colored clays.

A vertical shaft was sunk to 125 feet, primarily to learn the line of strike and direction of dip of the coal measures. The site of this shaft is 10 feet from a diamond drill, cutting 2 inch core, bore hole. The drill had located two seams of coal,

but having ground a large proportion of cores, cross-cuts were put in at right angles to the strike to determine the exact thickness of the seams. At from 171 feet to 182 feet vertical depth, the drill cut a bed of very coarse hard "Post" sandstone, but at the 125-foot level this bed showed all the structure of sandstone—yet it was all clay without a particle of grit. In such a weathered zone it was hopeless to expect the coal seams to be other than very dirty, nevertheless cross-cutting a "dig" where one man on each face could break more ground than two muckers could get away, and two men on a windlass could haul, would allow the tape to be put on the seams. Moreover, the faces were veritable herbariums, albeit the plants were leached fossil flora. Here, too, the cleavage system was seen—greasy, treacherous "heads." It seemed as though some movement in the country had taken place, but any such assumption was precluded by the fact that perfect *Sphenopteris* fern leaves laid unbroken over the cross-joints. The cross-cuts proceeded, and the middle seam was reached first, a purple with brown "mush," damp and so tender that it was difficult to preserve a fair-sized block. Yet the mass was stratified as cleanly as a book of cigarette papers.

Our consulting geologist, Mr. R. Logan Jack, F. G. S., ex-Government Geologist of Queensland, the discoverer of Queensland's artesian water supply, and the first observer to demonstrate that the Dawson-Mackenzie coal was anthracite, submitted a sample of this "coal seam" to Mr. R. Etheridge, who reported:

"Block of unctuous clay, the whole mass permeated with vegetable tissue in the condition known as 'skeleton leaves,' but there is no definite form or outline to the fragments."

Subsequently the other two seams were cut, the results being identical with the first. These "coal seams" were so opened in June, 1910; today, at time of writing, August, 1911, the blocks which were sun dried present a new appearance—gray, dry, crumbly slate showing indistinct forms of fossil flora. It need scarcely be added that neither of the three seams at the 120-foot level possessed the decimal of 1 per cent. of combustible.

In the bore hole, the diamond drill passed out of the said middle seam at 251 feet vertical depth. It should have commenced at 223 feet and yielded 28 feet of core. But from 222 feet to 233 feet only about 15 inches of core in fragments were recovered. These fragments were coalized *Glossopteris*, *Sphenopteris*, and *Calamites* in a greasy carbonaceous shale. From 233 feet to 251 feet the fair proportion of cores obtained showed small seams or layers of coal, which on analysis proved very ashy, interbedded in unctuous shale which yielded about 32 gallons of oil per ton. Thus, in 125 feet the seam had gained some combustible properties.

The bottom, or 9-foot seam, was struck by the drill at 328 feet vertical depth. More coal flowed over the casing of the bore hole than was recovered as core. The gutter was lined with diamond-grained coal, and the sumps were covered with floating particles. Withal, a proportion of core from that obtained, particularly in the run from 351 feet to 361 feet, layers of "dice," or diamond-grained coal, 1 inch to 2 inches in thickness, gave by analysis the following results:

	Per Cent.
Hygroscopic moisture.....	1.2
Volatile hydrocarbons.....	6.0
Fixed carbon.....	86.3
Ash.....	5.8
Sulphur.....	.7

These layers of coal were interbedded in coaly shale with thin layers of coal, the proportion of coal being about one to five of shale. The shale is characterized by its very distinct woody structure. This unctuous variety of black coaly shale, pulverized and roasted in a muffle furnace till everything combustible had been burned, resulted in leaving 30.85 per cent. ash. Eliminating the moisture, the combustible worked out as 67.45 per cent.

Summed up, the weathering of these coal seams read:

Outcrops to, say, 100 feet = blue-pug plastic clay.
 At 125 feet = skeleton leaves; no combustible.
 At 250 feet = poor oil shale; 20 per cent. combustible
 And coal = moisture 1.9; volatile hydrocarbons 7.3; fixed
 carbon 55; ash 35.8 = 100
 At 360 feet = coal: Fixed carbon 56.3, as shown above.
 Unctuous black coaly shale, woody, with 67.45 per cent. of
 combustible.

Thus, apart altogether from the actual coal, the combustible improved from nil at 120 feet to 67.45 per cent. at 360 feet, or in the ratio of .281 per cent. per foot. The improvement did not average .281 per foot in the upper levels, but averaged higher as vertical depth was attained.

There are cogent reasons for assuming that one of the said three seams is identical with a seam yielding coal having the following composition:

	Per cent.
Moisture.....	1.7
Carbon.....	80.3
Hydrogen.....	3.1
Nitrogen.....	1.8
Sulphur.....	.6
Ash.....	35.2
Oxygen (by difference).....	4.3

In practice this fuel used in a boiler furnace evaporates 9.7 pounds of water from and at 212° F. per pound; and used on a railway locomotive, 3 feet 6 inches gauge, the consumption per train ton-mile is .1243.

At 100 feet deeper than where now opened it is a reasonable assumption that the ash will be lower and the hydrogen higher.

The Charley Coal Mines Proprietary, Ltd., are engaged in sinking a main incline (31 degrees) shaft to cut the said three seams at a vertical depth of 500 feet. From that level a cross-cut is projected for the purpose of opening up other seams of coal located by diamond drill, and for reaching the axis of the Charley syncline. The evidence forces the conviction that not a ton of coal true to type, otherwise unaltered, has yet been mined from the Dawson-Mackenzie coal field. Hence, the Charley company's policy is to produce coal from and below the 500-foot (vertical depth) level.

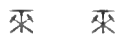

Trade Notices

Waterproof and Fireproof Brattice Cloth - It has not been found difficult to make a serviceable waterproof brattice cloth, or one that was practically fireproof, but when it has been attempted to make a cloth that is both waterproof and fireproof it has usually resulted in one or the other quality being sacrificed to some extent. The American Rubberfelt Co., 209 Chamber of Commerce, Chicago, Ill., controls the Rubbertex process of waterproofing cloth which completely saturates the fiber, and has recently discovered a process whereby cloth so treated can be made fireproof while still retaining its other good qualities. Users of brattice cloth should write them for information.

Power and Transmission is the title of a catalog recently issued by the Jeffrey Mfg. Co., Columbus, Ohio. They state that more subjects are listed and there is more technical and real information in this book than in any other publication. The complete line is listed and the information given in a way that will make the book valuable to the engineer in charge of an industrial plant, mine, or mill. Besides listing dimensions and sizes of every part in this line, there is descriptive matter on the horsepowers of steel shafting, standard methods of key seating, sizes and dimensions of couplings, hangers, pillow blocks, counter shafts, belt tighteners, clutches, quills, improved split iron pulleys, wood split pulleys, and very complete description and information on rope driving. There is also a complete list of the Jeffrey gears, including spur, bevel, miter, angle reduction, and angle miter. A new method of arriving at the horsepower

is given, besides complete information about dimensions and speed, horsepower of belts, and method of calculating bending and torsional moments for shafts.

Exhibit of First-Aid Outfits - During the National first-aid meet in Pittsburg, Johnson & Johnson, of New Brunswick, N. J., had a comprehensive display of first-aid-to-the-injured appliances. The exhibit was composed of emergency outfits designed not only for mines, mills, and railways, but also for autoists, travelers, campers, and the home. The exhibit was largely attended by miners, mine managers, operators, and others interested in first-aid work. First-aid books published for the average person who wants to make himself familiar with what to do and how to act in all cases of injury go with these outfits, or can be had for 50 cents by writing to Johnson & Johnson. Several of the large coal companies in the East who have been engaged some time in first-aid work, besides the Pennsylvania, Delaware, Lackawanna & Western, and New York Central railroads, have pocket first-aid packets designed for their particular use. These are manufactured by Johnson & Johnson, as well as small and large kits containing all kinds of appliances for the relief of the wounded.

Coaling Stations.—The large amount of coal used by locomotives and the necessity of handling it quickly has caused the importance of proper coaling stations to be appreciated by the railroads. A bulletin recently issued by Roberts & Schaefer Co., of Chicago, describes and pictures a number of Holmen coal and sand stations that have been installed by that firm, who control the patents for the special machinery used in connection with them.

Exhibits at American Mining Congress.—The following is a list of the firms that had exhibits and representatives at the meeting of the American Mining Congress: Western Electric Co., New York, Gregory Brown; Roberts & Schaefer Co., Chicago, Ill., Warren Roberts; Fairmont Mining Machinery Co., Fairmont, W. Va., S. M. Casterline; Sanford-Day Iron Works, Knoxville, Tenn., Hugh W. Sanford; General Electric Co., Schenectady, N. Y., W. T. Dean; The Kennicott Co., Chicago; W. D. Allen Mfg. Co., Chicago; Sullivan Machinery Co., Chicago, R. D. Hunter; Leschen Wire Rope Co., St. Louis, Mo.; Goodman Mfg. Co., Chicago, Charles T. Roeder; Link-Belt Co., Chicago, J. H. D. Petersen; S. F. Bowser & Co., Ft. Wayne, Ind.; John A. Roebling's Son's Co., Trenton, N. J., H. C. Hampton; Wire Rope Lubricating Co., Newark, N. J., R. W. Tobin; Hockensmith Wheel and Mine Car Co., Penn Station, Pa., W. D. Hockensmith and C. L. Herbster; The Hill Pump Valve Co., Chicago; C. O. Bartlett & Snow Co., Cleveland, Ohio, C. O. Bartlett; The Draeger Oxygen Apparatus Co., Pittsburg, Pa., Mr. Morris; Green, Tweed & Co., New York City; Osborne High Pressure Joint and Valve Co., Chicago; Jeffrey Mfg. Co., Columbus, Ohio, R. H. Jeffrey; Eugene Dietzgen Co., Chicago, G. C. Moore; Orenstein-Arthur Koppel Co., Chicago, G. R. Rabbett; Streeter-Amet Weighing and Recording Co., Chicago, Will Ball; Hills-McCanna Co., Chicago; American Rubberfelt Co., Chicago, Robt. De Lacy; Christy Box Car Loader Co., Des Moines, Iowa, J. M. Christy.

Air Compressing Under Difficulties.—In the California oil fields at Moron, Kern County, is an air compressor for air-lift pumping. It is located out in the open, exposed to the full glare of the sun where the temperature runs from 105° to 125° F., at midday, even in the shade with proper ventilation, and where the slightest breeze carries dust and sand upon the machine. Under these trying conditions the compressor operates 24 hours per day and is proving satisfactory. The machine which is made by the Chicago Pneumatic Tool Co., has compound-steam, two-stage air cylinders, with mechanically moved intake valves, and is equipped with a complete gravity lubricating system with drip returned, and there is also a small pump lifting the oil from the drip to the reservoir above the machine. The satisfactory operation of this machine under these circumstances speaks well for the design and workmanship of its builders.

Alarm—An alarm to indicate the approach of fire, especially underground, is an important means of safety. A device made for this purpose by the American Safety and Mine Supply Co., operates a bell by means of a car in motion. It is simple in construction and constitutes an "efficient alarm" under the law, and is in use extensively by the D., L. & W. Coal Co., the Delaware and Maryland Co., the H. C. Frick Coke Co., and others. Three models of the machine are now made, one consisting of an automatic bell only, another of a bell and an open torch, and a third of a bell with a storage battery electric light and a red lens for use in gaseous mines.

Canadian Branch.—The American Blower Co., of Detroit, Mich., has filed an application for charter for a Canadian company to be known as the Canadian Sirocco Co., Ltd., of Windsor, Ontario, and shop and office buildings will be built in that city at once. The company will manufacture the Sirocco fan and a full line of products of the American Blower Co., including blowers, heating, ventilating, drying apparatus, steam engines, steam traps, etc.

Temperature of Flue Gases—The Green Fuel Economizer Co., of Matteawan, N. Y., are supplying temperature pendants free of charge to any one who may wish to determine the temperature of fuel gases. These pendants are pieces of metal which will melt at the temperatures stamped in figures upon them. All sorts of devices for valuing the different losses in the operation of steam power plants are now receiving the close attention of engineers, and these pendants and a description of their use will be furnished on application.

New York Office.—Frederick P. Cook, formerly secretary of the Milwaukee Locomotive Mfg. Company, Milwaukee, Wis., has been placed in charge of the New York Office of the Company with head quarters at 111 Broadway. Mr. Cook will handle the sales of Milwaukee gas driven locomotives in the states of New York and New Jersey, and will also look after the company's foreign business.

采 采

Swimming Pools for Mining Towns

Cleanliness being next to godliness and swimming being the very best kind of exercise and fun, the H. C. Frick Coke Co. have at their Leisenring No. 1 mine constructed the pool shown herewith. Thomas W. Dawson,* assistant chief engineer, who kindly furnished the illustration, gives the following information concerning the innovation:

This pool is 40 feet wide, 80 feet long inside measurements, about 2 feet deep at one end, inclining toward the other end until a depth of 7 feet is reached at a point 16 feet from the end, the bottom then raises 6 inches in this 16 feet, the lowest point being the drainage one. The side walls and bottom are made of reinforced concrete. There are provided two bath houses, the larger one containing six shower baths for the men, and

Scottsdale, Pa.

the smaller one four for the women. Hot and cold water is provided and any one entering the pool is required to take a shower bath.

There is a competent man in charge and he is always at the pool in case his assistance is required when there are bathers in the pool. Saturday afternoons are set apart for women only.

This pool is very popular, being used by the youngest to the oldest persons at the plant and by employes from the other mines in this vicinity, also by persons from nearby towns who are not employed by the H. C. Frick Coke Co. On account of the success of the plan there is contemplated the erection next spring of a number of pools at the other plants.

采 采

Bordeni—Roumania's Newest Oil Field

Great activity is now being displayed in the development of Bordeni-Doftanet-sec region of Roumania. The companies actively engaged in developments are the Central Roumanian Co., the Anglo-Roumanian Oil Co., the Concordia, and the Columbia companies. The absence of a pipe line has prevented transportation and hence greater production of crude oil. The Concordia company struck oil at a depth of 1,100 feet, from which it obtained 200 to 250 tons daily. This well was of importance since it proved that the Bordeni oil zone extended much further north than was expected. The Anglo-Roumanian Oil Co., at a depth of 846 feet, struck oil which flowed at the rate of 50 tons per day. In the same vicinity the Concordia company struck oil which flowed at the rate of 40 tons per

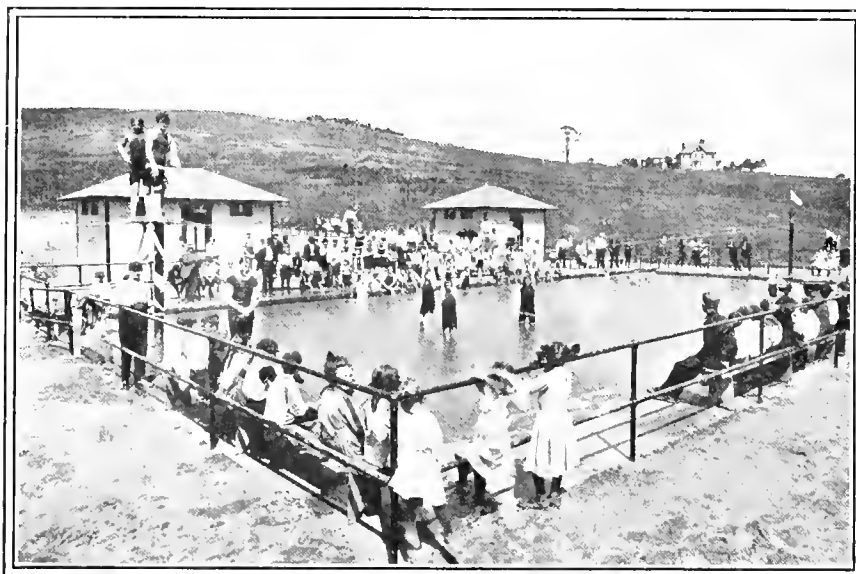

SWIMMING POOL AT LEISENRING MINE

day. It is now believed that only a small portion of the Bordeni oil field has been exploited.

采 采

Obituary

JAMES BENTON GRANT

Hon. James Benton Grant, one of the early governors of Colorado and a pioneer of the American ore-smelting industry in the West, died November 1, at Excelsior Springs, Mo.

Governor Grant, as he was usually called, was born near Columbus, Ala., in 1848. After the Civil War in which he was a participant, he studied civil engineering at the Iowa State Agricultural College, and at Cornell University, and mining and metallurgy, at the Royal Mining Academy, Freiberg, Germany. He joined in the first "rush" to Leadville in the latter part of 1877 where, with William H. James and Edwin Eddy, he established the ore-buying and sampling works of J. B. Grant & Co. In connection with the sampling works a smelter was erected, but its destruction by fire in 1881 led to the incorporation of the Omaha & Grant Smelting Co., with a plant at Denver, which later was absorbed by the American Smelting and Refining Co. Mr. Grant was a director of the latter concern, a position he held at the time of his death.

Western Coal Land Legislation

The Present Coal Land Law—System of Leasing to Avoid Long Time Speculative Investment

By George Otis Smith

At the American Mining Congress, at Chicago, October 27, the following paper under the title "What the West Needs in Coal-Land Legislation," was read by George Otis Smith, Director United States Geological Survey.

In any discussion of the needed revision of our public land laws, a due share of attention must be given to the statutes relating to the coal lands. While certain classes of lands in the western states have largely passed into private ownership, the public's holding of coal lands is still large enough to deserve most serious consideration. West of the one hundredth meridian lies the nation's greatest coal reserve, estimated at more than a million million tons of anthracite, bituminous, and subbituminous coal, and title to from 60 to 85 per cent. of this tonnage is in the United States. It is self-evident that this fuel reserve is the key to the present and future industrial development of the Rocky Mountain region. Utilization of the water-power resources will be an important factor locally, and for several decades fuel oil may be expected to affect the industrial situation, but so far as we can now foresee coal must be regarded as the principal source of power. Its present importance is shown by the fact that the coal production of the Rocky Mountain states was 14.7 per cent. greater in 1910 than in 1909, although for the whole United States the increase in coal output for the same period was less than 9 per cent. Utilization of these western coal deposits that will meet both present and future demands is the end that must be served in whatever public policy is adopted. The West needs, and has a right to demand, full opportunity for legitimate, energetic business development, but that does not include the right to inflict an unearned speculative tax on the future consumer.

Full opportunity on the public coal lands can be defined both from the standpoint of the coal operator and from the point of view of the consuming public. The operator can justly ask two things: First, the right to occupy an acreage sufficiently large for economic operation during an average mine-life period; and second, freedom from too great investment risks. Economic operations we will understand to mean the installation of such equipment as will secure maximum recovery at low cost with proper safeguarding of both life and property, while excessive investment risks refer to capital outlays out of proportion to expected profits of operation. Both of the factors are in reality of hardly less interest to the public than to the operator, for upon them depend in the last analysis much that determines prices and concerns general welfare. The public should also demand that no right to the public coal land shall be granted except for present use. Actual development must be made the first condition of occupancy of any part of what now remains in the public domain.

The present status of coal mining in the West is the resultant of two factors, land ownership and consumptive demand for coal. The large holdings of coal land legitimately acquired through railroad grants and those secured by coal companies through dummy entrymen, and by purchase of agricultural entries as well as those patented to the states as non-mineral lands, together constitute a coal-land supply that has practically met the demand. The strict administration of the public domain during the past few years, however, has shut off all opportunity for wholesale accumulation of coal lands under cover of the homestead and other laws. Up to the present time the acquisition of the coal land in the public domain has been largely accomplished without recourse to the coal-land law, so that the question becomes opportune—is the present coal-land law adequate to meet present and future needs?

This law relating to coal lands is less unsatisfactory than many of the mineral land laws now on the statute books. By its provision for the valuation of coal lands at an adequate price the law makes possible a selling price that may promote development and at the same time prevent monopolization. As is pointed out in a public statement by Secretary Fisher, the present governmental policy of basing the valuation of public coal lands upon the tonnage and quality of coal which underlies the tract results in prices that are neither unreasonable nor exorbitant; the purchaser instead of paying a flat rate per acre in reality pays for the coal by the ton at values graded according to the quality and the character of the coal. Consideration is also given to every known physical and commercial factor affecting the value of the coal of the particular locality. The purpose has been to protect the present interests of the West by making the selling price of coal land approach, but in no case exceed, the present purchase value of a royalty under a leasehold, such as the states of Colorado and Wyoming, or land companies in the West, grant to the lessee, and at the same time to protect the future interests of the people by having these prices such as to discourage long-time speculative holdings. We must always keep in mind the fact that large speculative holdings are sure to affect the future price of coal in two ways; through the possibility of monopoly and through the certainty of accumulated interest charges on the cost of the idle land.

The test of any policy is in the results it produces. That the prices put upon the public coal lands are not prohibitive can be shown by the record of sales. In the four years following the adoption of the policy of classifying and valuing the coal lands, the sales have increased 12½ per cent. in acreage and 36 per cent. in value as compared with the four years preceding, and this in spite of the fact that the four years since July 1, 1907, have included a period of industrial depression and slow recovery as contrasted with the preceding period of boom conditions. So far, therefore, as its provision for pricing is concerned, the present law appears to be as satisfactory as a sale law can be.

One serious defect exists in the present law which all must admit demands an immediate remedy. The restriction of legal purchases to a maximum of 160 acres for an individual or 640 acres for an association is absurdly out of accord with good mining practice. The fixed charges of a modern coal mine equipped so as to safeguard life and property and to secure maximum recovery are too high to be assessed against the tonnage of so limited a tract, especially where the coal seam is of moderate thickness. Furthermore, unless provision is made for commercial operation on the remaining lands, too great an advantage is secured to the land-grant railroads and the large coal companies already in possession of considerable areas of high-grade coal. There is no public need of having either individuals or large corporations acquire large acreages of these lands for long-time holding without development. Nor is there any sound economic reason for the disposition of the coal lands in small tracts. The homestead law expresses the spirit of American institutions in that it has encouraged every citizen to own a home, but there is neither sentiment nor sense in a proposition to sell at a low price 160 acres of coal land to an individual—every citizen does not need to own a coal mine.

In the endeavor to discourage long-time speculative investment in the coal lands and at the same time permit present development, the fixing of selling prices has involved difficulties. It has been recognized that an ideal adjustment of values is well nigh unattainable for many if not for most coal lands. These difficulties suggest the wisdom of considering the other method of disposition, namely, a leasing system. As Secretary Fisher has stated: "It may well be that a liberal but wisely protected leasing law would be found to promote development more vigorously than any system of outright purchase." Thus, under a leasehold law any uncertainties as to quality of coal or as to costs of operation would not need to be so critically

estimated by the mine. There will be no necessity of discounting every year for the future condition, but periodic adjustment of rate of royalty could insure all equities of both operator and public, and I should expect that such adjustments might as often be downward as upward.

Under a leasing system, too, it would be comparatively easy to adjust the relationship between ground rental and royalty to prevent the acquisition of coal deposits until actual operation becomes profitable. The greatest advantage of the lease system to the operator directly, and to the public indirectly, is relief from the large capital outlay now required in the acquisition of the large acreage absolutely necessary for a modern mine. This argument advanced against the present policy of valuing the public coal lands at even conservative prices thus becomes an argument for a leasehold law.

The objections to a leasing system are of two classes; those based upon political theory and those based upon economic considerations. Under political objections I will place the arguments so often put forward against Federal landlordism, namely, that the Eastern coal lands were disposed of in fee and that the West deserves the same treatment; and further, that the natural resources of the West should not be made a source of profit to relieve the Eastern taxpayer. Such arguments can be easily answered. Past mistakes are poor precedents for future blunders. The citizen who argues for the continuance of the liberal, wide-open public-land policy of the past is apt to be one who wishes a middleman's profit on a small investment, and we know that East or West, the owner of coal lands acquired as agricultural lands, or in any other way, at a low price, makes his large and unearned profit out of the coal operator, and through him, out of the public. Too large a percentage of the coal output of this country is now mined under lease to justify this objection to allowing the people themselves to lease it direct. As regards the argument of reserving western resources for the West, too few people in the public land states realize that under the present system of sale, the proceeds from the coal lands go directly into western development through the Reclamation Fund, and cannot be used to relieve the eastern taxpayers except as the whole country benefits by the agricultural development of these public land states.

It is reasonable to expect that any leasing law would make similar provision for the local use of revenues resulting from leases, and indeed several of the bills already introduced in Congress have specifically recognized the wisdom of such disposition.

Much more worthy of consideration are the objections to the lease system based upon the fear that the cost of coal to the consumer would be increased, but this result is altogether improbable. The royalty paid into the United States treasury can be no greater a tax upon the consumer than the royalty paid to the state of Colorado, or to the railroad land company, or to the farmer. The average price of bituminous coal at the mine, in the United States last year, was \$1.12, which usually includes either a royalty or an equivalent interest charge, either of which would probably be greater than any government royalty. This amount forms so small a part of the price to the consumer that the royalty under a federal lease could be of but little concern to the public, if, indeed, it resulted in any increase in the first cost of the coal.

However, if we consider the lease as contrasted with sale outright to the coal operator, the reduction in capital necessary for original investment and the elimination of many of the risks in such investment, must result in reducing cost of operation to the mine owner, and thus make possible a correspondingly lower price of coal to the consumer.

The other objection to the lease system is that based upon fears of expensive federal management, and of inefficient administration or even maladministration. These are possibilities which we must squarely face; but faith in the efficiency

of public administration is increasing to such a degree that this argument against the leasing is rapidly losing its force. The Anglo-Saxon people of the Australasian states have found the leasing system not only practicable, but indeed preferable to the sale of coal lands. In New Zealand, where for 30 years the laws have permitted to the operator a choice of either sale or lease of public mineral lands, a conclusive argument for the leasing system is given in the latest statistics of mineral production, which show that approximately 90 per cent. of the total mineral product of that country was mined under leasehold.

Uncle Sam is a landlord on a large scale—a coal baron if you please; and the question is how these millions of acres of coal lands are to be disposed of so as to serve the just needs of the operator who offers his capital, technical skill, and business experience, asking in return a fair profit, and at the same time to protect the public interests.

All that the West needs is, first, opportunity for the coal industry to develop as fast as the market justifies expansion and with the least possible risks; and second, opportunity for the public to secure its coal at prices based on a minimum cost of production and without any addition of unearned and undue tribute to private landlords who desire to speculate on the future needs of the consumer. These ends I believe can be best attained by legislation inaugurating a federal leasing system for coal lands of the public domain.

來 來

Repairing Broken Steel Tapes

Steel measuring tapes are often broken even when handled with care, consequently all surveyors who have experienced the inconvenience resulting from breaking a tape will be thankful to J. A. Smith, E. M., of the Cumberland Coal Co., Albert, W. Va., for furnishing the following simple and ready means for their repair.

The following outfit for quickly repairing a broken steel measuring tape can be carried without inconvenience by the engineers when surveying. It consists of a small vial containing a solution composed of zinc chloride ($ZnCl_2$) dissolved in as little water as possible; a few inches of $\frac{1}{8}$ -inch round solder such as electricians use; several thin pieces of tin $\frac{1}{8}$ -inch wide, as shown at *a*, Fig. 1, that are twice as long as the tape is wide; and a pocket knife. The zinc-chloride solution vial should be carried in a small round tin box and kept from moving about by means of cotton wool to prevent breakage. If the small strips of tin are bent in advance to form sleeves as shown at *b*, that are just large enough to slip over the ends of the broken tape, as shown at *c*, the repair can be made rapidly.

To make use of the repair kit, wipe off all dirt and scrape off all rust from, and brighten with a knife, the ends to be united. Dip each end in the zinc chloride solution, then slip the tin sleeve over the ends of the tape, after which put them closely together. Hold the joint sleeve over a mine lamp flame if in the mine or over a match flame if outside. The tin and tape being thin heat rapidly, and if solder is touched to the joint it will melt and fill all spaces. To quickly cool the soldered joint, shown at *d*, it is customary to spit on it. (Pepsin gum will furnish clearer saliva than plug tobacco.) In case too much solder sticks to the joint, the surplus should be brushed over while hot and before wetting.

It is surprising how quickly and with what little practice a neat joint can be made which is as strong as the original tape, stronger than a riveted joint, and one which does not interfere or give trouble when reeling up.

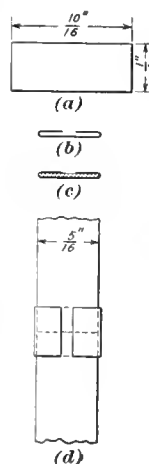

FIG. 1

Method of Supporting Mine Roofs

Blasting Down Roof and Blasting Up Floor to Form a Dam, Then Filling Back of Dam

William Griffith, mining engineer and geologist, of Scranton, Pa., has been granted patent number 1,004,419 for a method of mining. It is not claimed that the method will cover every case, for instance, where there is a steep pitching coal bed, or where there is an extra thick flat coal bed; in fact it is applicable only to moderately pitching beds and flat beds. The best possible explanation of the system is given in the patent specifications, which are reprinted in part for the benefit of our readers.

In mining in the United States and in various other countries a general system or method is used for removing the matter to be mined, especially in mining coal. The ordinary system in the United States, for instance, is to mine out part of the coal and leave part of the coal as supporting pillars for preventing the roof of the mine from caving in or collapsing. This method of mining is varied according to the position of the coal veins in the rock for permitting mining horizontal veins or pitching veins. The mining of horizontal veins by the ordinary method contemplates the sorting of the coal from the slate and other refuse in the room or that part of the mine from which the same has been removed from its natural bed. The coal is transported to the surface and disposed of as desired, while the refuse is deposited at one side of the room and in any place most convenient so that the same will not be in the way of further mining or the removal of the coal. Where the coal vein occurs in what are known as pitching veins, all of the mined material, including the slate and other refuse, falls or slides down to the car which conveys the same to the surface or to a place from which the same may be conveyed to the surface. This method necessitates the removal of all the coal mined, and the sorting of the coal from the refuse after the coal and refuse have been removed from the mine.

This invention is intended to obviate as far as possible any injury or breaking down of any property on the surface of the ground, and at the same time render available for shipment a maximum quantity of coal from a given coal field without endangering the lives of the miners or life and property on the surface of the ground.

The process or method consists in blasting up the floor, which is usually rock, or blasting down the roof of the mine, or if desired blasting up part of the floor and blasting down part of the roof directly over the same and allowing the debris of the blasting to remain where it falls and thus take advantage of the well-known characteristics of blasted rock, that it occupies considerably more space

than when in the solid condition, but affords a good artificial pillar which will resist vertical strains and lateral strains. The roof and floor may be blasted up in this manner for entirely inclosing a predetermined space by the blasted material, or for closing the ends of a room into which filling material of any kind, as for instance sand and solid refuse

matter is flushed for filling the chamber or inclosure made by the blasted rock until the same is entirely filled by said flushed-in matter. As will be evident the blasted-up rock will be anchored in the floor and roof and the broken rock will naturally be interlocked so that any lateral strain brought to bear against the same by the sand and other flushed-in matter will not affect detrimentally the blasted material, but on the contrary the blasted material will hold against lateral movement the flushed-in matter, so that the flushed-in matter will act as a proper support or pillar for the roof.

In the accompanying drawings is disclosed a concrete example of the method or process involved. The drawings show how the process may be used in a flat or horizontal mine, and also in a pitching vein mine. Either after the mine has been partly worked or abandoned or during the mining operation, part of the floor is blasted up at *a* and part of the roof is blasted down at *b* for forming a dam or what is sometimes called a battery *c* which incloses a room or space *d*. As will be noticed from Fig. 1 the dam *c* extends entirely around the room or space *a*, and consequently will firmly support against lateral movement any matter flushed into the room through opening *e*. Opening *e* indicates a bore extending to the surface through which water, sand, and other material is flushed into room *d* where the solid matter settles and the water drains through dam *c*, and is removed from the mine in any desired manner, as for instance by the usual pumping apparatus. If desired instead of having the bore *e* extend to the surface of the earth a tube or pipe *e'* could be inserted into room *d* in any desired way and sand or other matter flushed into room *d* until the same is full of solid matter, which will consequently present a pillar for supporting the roof in addition to the support the dam *c* will afford. After the room *d* has been provided with material for a pillar the material may be mined from either side thereof to a considerable extent, and then a new dam made for an additional room which may be flushed in a similar manner. This process may be continued throughout the entire mine so that the roof will be continuously supported and yet all the coal removed so that there will be no danger to the miners, and also no material sinking of the earth's surface above the mine.

When mining a pitching vein, as disclosed in Fig. 2, the mining is done according to any of the usual methods, or any improved method desired, until a room *f* is provided which is closed by having the material from the floor blasted up at point *g*, while material from the roof is blasted down at point *h* for providing a dam *i*. Dam *i*, together with the usual pillars *j* formed of coal, supports the roof, and will form an entirely inclosed chamber. The respective pillars *j* formed of coal are connected by suitable partitions *j'* formed of any desired material. These partitions are placed in position during the mining operation and cause a proper circulation of air for the benefit of the miners. After having served this purpose they are left in position and act as lateral supports for the flushed-in material, and are especially of advantage during the settling of

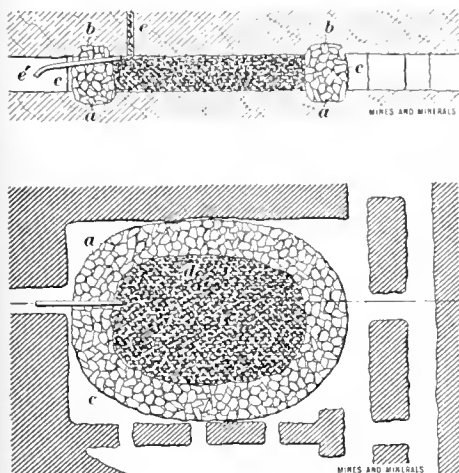

Fig. 1

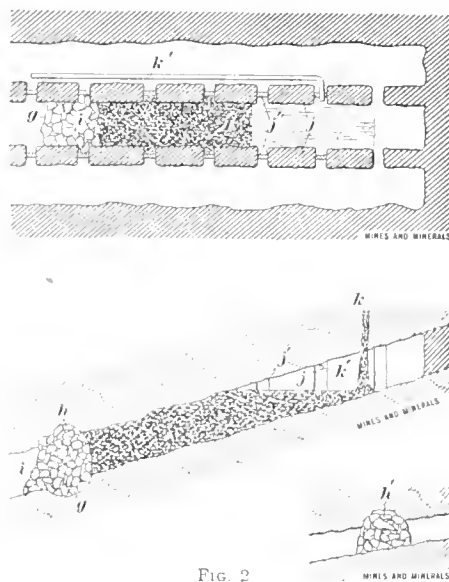

Fig. 2

The pipe k' may be inserted into the chamber i at any part of the mine, or a boring k may be drilled which extends from the surface of the ground, and other filling material may be flushed into the chamber. The same settles and forms a firm, solid support, and the water drains off through dam i . After the room f has been flushed the pillars on one side may be removed if desired and the space occupied by the same and the adjoining room flushed out and or other filling material in a similar way to the way room e is filled after a dam similar to dam i has been provided for the adjoining room. In this way the usual form of mining may be proceeded with to a certain extent and then by my improved method the roof properly supported and all the coal supporting pillars removed so that a maximum amount of coal may be delivered from a given area.

As seen in Fig. 2 the roof may be blasted down at point h' sufficiently for making a complete dam. This may be easily done where the vein is comparatively narrow, as sufficient material may be blasted from the roof without causing an undesirably strong explosion.

My improved method may be used during the first mining or in old or abandoned mines. Where the method is used in abandoned mines some of the supporting pillars are removed and an inclosure or room is made by blasting up part of the roof or floor or both for providing an inclosure for the flushed-in material. Also if desired some of the original supporting pillars may be used as one side of the room into which material is flushed, though preferably an entire space is inclosed by blasted material, as shown in Fig. 1, which is always left in place so that when the same has been once filled with flushed-in material a permanent solid supporting pillar is provided.

What I claim is:

1. The method of mining comprising the blasting of the floor of a mine for partially filling the mine at the point of blast, then blasting down a sufficient part of the roof for filling the remaining open space in the mine, the blasted material being allowed to remain where it falls for filling the open space in the mine and the space caused by blasting for providing supporting means for the roof, and then flushing of filling material in the mine at one side of said blasted material.

2. The method of mining which comprises the running of gangways along the body of material to be mined, forming rooms at one side and connected to these gangways, taking out the material to be mined and packing the refuse in said rooms on the sides of the rooms, blasting up part of the floor of the room at a point desired to be closed for partially filling the space between the floor and the roof, blasting down a sufficient part of the roof for completing the dam, forming a pipe opening into said room closed by said dam, and then flushing material into said room.

3. The method of mining which comprehends running gangways along the body of material to be mined, working out the material to be mined in proximity to the gangways, piling the waste material in the space from which the mined material has been moved, blasting down a sufficient part of the roof at any desired point for forming a dam, forming a flushing opening communicating with the space in front of said dam, and flushing filling material through said flushing opening.

4. The method of mining which comprehends running gangways along the body of material to be mined, working out rooms in proximity to the gangways, placing charges of explosives in the floor and roof of said rooms at a point where a dam is desired, successively discharging the explosives in the floor and roof for providing a dam formed of crushed material of the floor and roof for providing an auxiliary support for the roof and a dam for any material flushed in said room, forming an opening through which material may be flushed into said room, and flushing material into said room.

5. The method of mining which comprises the running of gangways along the body of material to be mined, forming

rooms along one side of said gangways and connecting the rooms to said gangways, blasting up part of the floor of any of the rooms in which a dam is desired, and leaving the blasted material in the place where it falls, whereby a dam for part the height of the room is provided having an anchorage in the floor, then blasting down a sufficient part of the roof for filling the space immediately above said first mentioned blasted material for providing an artificial pillar, and a completion of the dam with an anchorage in the roof, and then flushing filling material into the room.

6. The method of mining which comprises the running of gangways along the body of material to be mined, forming rooms to one side of the gangway and connecting the rooms to the gangway, blasting up part of the floor of said rooms in such a manner as to form an inclosing fence, blasting down part of the roof of said rooms immediately above said first mentioned blasting for forming said fence into a complete dam having anchorage in the floor and roof, and then flushing material into the inclosure provided by said dam.

來 來

Book Review

TECHNICAL ANALYSIS OF BRASS. John Wiley & Sons, of New York City, send for review a book entitled "Technical Analysis of Brass," by W. B. Price, chief chemist Scovill Mfg. Co., and Richard K. Meade, director of Meade Testing Laboratories. The book is divided into three parts, as follows: Introduction, Determination of Metals, and Examples of Alloy Analysis. The book contains 265 pages with index and it appears to be adapted to the use of analytical chemists generally. The price is \$2 net.

PRACTICAL GEOLOGY AND MINERALOGY is an elementary treatise, designed for students, miners, prospectors, and those who desire to know something of geology, petrology, mineralogy, and mineral deposits in a general way. It is written by W. D. Hamman, B. Sc., from his standpoint as a practical man. In his preface he states: "Science is a dry subject to many if presented in technical language. While it is impossible to treat science in story-book fashion, it is possible to popularize mining science by cutting out unimportant matter and confining the scope to simple practical every-day phases of the mining business." There are 224 pages of text to the book, but no index. It is published by the Way's Pocket Smelter Co., South Pasadena, Cal.

SHAPE BOOK CARNEGIE STEEL CO. We have received from John C. Neale, of the Carnegie Steel Co., Pittsburg, Pa., the new "Shape Book," of that company containing profiles, tables, and data appertaining to beams, bulb sections, channels, angles, tees, zees, and miscellaneous structural shapes; also to concrete reinforcement bars, clip sections, crescent sections, automobile sections, pipe sections, window sections and with a few unimportant exceptions all the shapes rolled by that company. It supercedes and cancels the book of Shapes issued in 1903, together with all supplements thereto.

METALLURGY OF TIN. McGraw-Hill Book Co., of New York City, have published a book from the pen of Henry Louis, M. A., D. Sc., A. R. S. M., on the Metallurgy of Tin. This book is in the main a reprint of a monograph on the Metallurgy of Tin, published in Vol. V, of the Mineral Industry. The price is \$2 net. The 138 pages are divided into five chapters with index. The subjects are Properties and Occurrence of Tin, Principles of the Metallurgy of Tin, Smelting in the Shaft Furnace, Smelting in the Reverberatory Furnace, Tin Plate and Tin-Plate Scrap. The author is well known to metallurgists and if anything relating to the metallurgy of tin is missing from this book, it is because the industry is surrounded with secrecy.

BOOKS RECEIVED

UNITED STATES GEOLOGICAL SURVEY PUBLICATIONS, Washington, D. C. Bulletin No. 442-J, Alaska Coal and Its Utiliza-

tion, by Alfred H. Brooks; Bulletin No. 467, Geology and Mineral Resources of Parts of the Alaska Peninsula, by Wallace W. Atwood; Bulletin No. 470-H, Advance Chapter From Contributions to Economic Geology in 1910, by R. W. Richards, G. R. Mansfield, H. S. Gale, and Elton Blackwelder, Bulletin No. 483, Economic Geology of Richmond, Va., and Vicinity, by N. H. Darton; Bulletin No. 486, Results of Spirit Leveling in Colorado, 1896 to 1910, Inclusive, by R. B. Marshall, Chief Geographer; Bulletin No. 488, Results of Spirit Leveling in Nevada, 1897 to 1909, Inclusive, by R. B. Marshall, Chief Geographer; Bulletin No. 489, Results of Spirit Leveling in Utah, 1897 to 1910, Inclusive, by R. B. Marshall, Chief Geographer; Zinc and Cadmium in 1910, by C. E. Siebenthal; The Production of Phosphate Rock in 1910, by F. B. Van Horn; The Manufacture of Coke in 1910, by Edward W. Parker; Silver, Copper, Lead, and Zinc in the Central States in 1910, by B. S. Butler and J. P. Dunlop; The Cement Industry in the United States in 1910, by Ernest F. Burchard; The Production of Iron Ore, Pig Iron, and Steel in 1910, by Ernest F. Burchard; The Production of Gems and Precious Stones in 1910, by Douglas B. Sterrett; The Production of Salt and Bromine in 1910, by W. C. Phalen; The Production of Slate in 1910, by A. T. Coons; Gold, Silver, Copper, Lead, and Zinc in the Eastern States in 1910, by H. D. McCaskey. Water-Supply Paper No. 261, Surface Water Supply of the United States in 1909, Part I, North Atlantic Coast, by H. K. Barrows, C. C. Covert, and R. H. Bolster; Water-Supply Paper No. 269, Surface Water Supply of the United States in 1909, Part IX, Colorado River Basin, by W. B. Freeman and R. H. Bolster; Water-Supply Paper No. 272, Surface Water Supply of the United States in 1909, Part XII, North Pacific Coast, prepared under the direction of M. O. Leighton, by J. C. Stevens, E. C. La Rue, and F. F. Henshaw. Professional Paper No. 73, The Tertiary Gravels of the Sierra Nevada of California, by Waldemar Lindgren.

UNITED STATES DEPARTMENT OF AGRICULTURE, Washington, D. C., Bulletin No. 99, Uses of Commercial Woods of the United States, Part II, Pines, by William L. Hall, Assistant Forester, and Hu Maxwell, expert.

BUREAU OF MINES, Washington, D. C., Bulletin No. 13, Résumé of Producer-Gas Investigations, by R. H. Fernald and C. D. Smith; Miners' Circular No. 5, Electrical Accidents in Mines, Their Prevention and Treatment, by H. H. Clark, W. D. Roberts, L. C. Hsley, and H. F. Randolph; Bulletin No. 24, Binders for Coal Briquets, by J. E. Mills; Bulletin No. 28, Experimental Work Conducted in the Chemical Laboratory of the United States Fuel-Testing Plant, St. Louis, Mo., January 1, 1905, to July 31, 1906; Bulletin No. 27, Tests of Coal and Briquets as Fuel for House-Heating Boilers, by D. T. Randall; Bulletin No. 35, The Utilization of Fuel in Locomotive Practice, by W. F. M. Goss.

DEPARTMENT OF COMMERCE AND LABOR, BUREAU OF THE CENSUS, S. N. D. North, Director, Washington, D. C., Bulletin No. 30, Census of Manufactures: 1905, Arizona, Indian Territory, New Mexico, and Oklahoma.

TWENTIETH ANNUAL REPORT OF THE BUREAU OF MINES, 1911, Volume XX, Part I, Toronto, Can

DEPARTMENT OF COLONIZATION, MINES AND FISHERIES, MINES BRANCH, Quebec, Can., Geology of a Portion of Fabre Township, Pontiac County, by Robert Harvie, Jr., M. Sc.

VIRGINIA GEOLOGICAL SURVEY, University of Virginia, Charlottesville, Va., Bulletin No. 6, Biennial Report on the Mineral Production of Virginia During the Calendar Years 1909 and 1910, by Thomas Leonard Watson.

NORTH CAROLINA GEOLOGICAL AND ECONOMIC SURVEY, Joseph Hyde Pratt, State Geologist, Chapel Hill, N. C., Economic Paper No. 22, Forest Fires and Their Prevention, Including Forest Fires in North Carolina During 1910, by J. S. Holmes, Forester.

GEOLOGICAL SURVEY OF TENNESSEE, George H. Ashley,

State Geologist, Nashville, Tenn., Volumes Nos. 1, 2, 3, and 4, The Resources of Tennessee.

SECOND AND THIRD ANNUAL REPORT OF THE CHIEF INSPECTOR OF MINES, from November 1, 1908, to June 30, 1909, and July 1, 1909, to June 30, 1910, Pete Harraty, Chief Inspector of Mines, McAlester, Okla.

COMMONWEALTH OF PENNSYLVANIA, Harrisburg, Pa., Report of Topographic and Geologic Survey Commission of Pennsylvania, 1908-1910

GEOLOGICAL SURVEY OF ALABAMA, Eugene Allen Smith, Ph. D., State Geologist, University, Ala., Bulletin No. 10, Reconnaissance Report on the Fayette Gas Field, Ala., by M. J. Munn; Bulletin No. 11, Roads and Road Materials of Alabama, by Wm. F. Prouty, Ph. D.

DEPARTMENT OF MINES, GEOLOGICAL SURVEY, Sydney, New South Wales, Australia, Mineral Resources, No. 13, The Forbes-Parkes Gold Field, by E. C. Andrews, B. A., F. G. S.; Annual Report of the Department of Mines, New South Wales, for the Year 1910.

OREGON AGRICULTURAL COLLEGE, Corvallis, Ore., Bulletin No. 110, "Preliminary Frost Fighting Studies in the Rogue River Valley," by C. I. Lewis and F. R. Brown.

采 采

Self-Oiling Tail-Rope Roller

A cheap and effective overhead tail-rope support in use at the Thor and Globe mines of the National Fuel Co., of Denver, Colo., is shown in the accompanying sketch. It consists essentially of a cast-iron roller supported by

two side pieces of $\frac{3}{4}$ " x 2" flat iron. To form the shank, these side pieces are welded together for about 2 inches and then sprung apart into a V shape. The length of the shank, which is inserted in a hole drilled in the roof, is variable, being about 6 inches for rock and 8 inches for coal. In placing

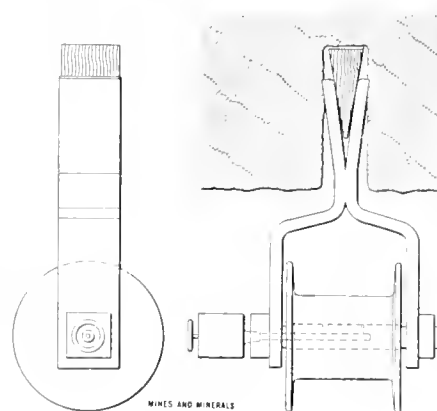

MINES AND MINERALS
SELF-OILING ROLLER

in position, the wooden wedge is drawn down about 2 inches, the shank fitted over it and the whole driven up as far as possible. As the wedge drives the shanks apart and into the roof, permanency is secured. In some cases additional wedges are placed outside the shank between it and the sides of the hole, and further security might be obtained if the device was cemented into place. However, at both the above mines, cementing is not employed and no falls of the sheave have been reported.

The roller turns on a 1-inch bolt, part way through the center of which is drilled a $\frac{1}{4}$ -inch hole with two $\frac{1}{8}$ -inch holes from this central channel to the outside of the bolt. The oil from a Bruno "00" automatic grease cup feeds in through the center $\frac{1}{4}$ -inch hole and out through the two $\frac{1}{8}$ -inch holes, insuring perfect lubrication. These rollers are set about 30 feet apart and make about 1,200 revolutions per minute. If made larger and set vertically they may be used to carry the rope around curves. In this latter case they would probably have to be made considerably larger and should be set in brackets.

The important principle involved is the use of the automatic oiling device which results, not only in a very material saving in lubricant, but of labor as well. The cost per piece, including grease cup, is a little less than \$2.

The National First-Aid Meet

Dust Explosion and First Aid Demonstrated Before President Taft and 10,000 People

The first National First-Aid Meet, at Pittsburg, Pa., on October 31, was an affair that will long be remembered by guests and participants. It was held under the auspices of the United States Bureau of Mines, American National Red Cross, and the Pittsburg Coal Operators' Association. Although rain prevented the attendance being as large as it otherwise would have been, nevertheless there were probably 10,000 spectators, who witnessed the demonstration on Forbes Field, and among them were President Taft, Secretary Fisher, Miss Boardman, Governor Tener, of Pennsylvania, and Governor Glasscock, of Ohio.

The following coal companies were represented by first-aid teams: Berwind-White Coal Mining Co., Windber, Pa., four teams; Consolidated Coal Co., Fairmont, W. Va., two teams; Cabin Creek (Y. M. C. A.), Decota, W. Va., one team; Delaware, Lackawanna & Western Coal Co., Scranton, Pa., two teams; Dunbar Furnace Co., Dunbar, Pa., one team; Ellsworth Collieries Co., Ellsworth, Pa., three teams; Lehigh & Wilkes-Barre Coal Co., Wilkes-Barre, Pa., one team; Lehigh Coal and Navigation Co., Lansford, Pa., one team; Lehigh Valley Coal Co., Wilkes-Barre, Pa., two teams; Miller Coal Co., Portage, Pa., one team; Northwestern Improvement Co., Tacoma, Wash., one team; Pennsylvania Coal Co., Scranton, Pa., one team; Parrish Coal Co., Plymouth, Pa., one team; Philadelphia & Reading Coal and Iron Co., Pottsville, Pa., one team; Pittsburg-Buffalo Co., Marianna, Pa., one team and brass band; Pittsburg Coal Co., Pittsburg, Pa., five teams; Pittsburg Terminal Railroad and Coal Co., Pittsburg, Pa., one team; Portage Coal Mining Co., Portage, Pa., one team; Republic Iron and Steel Co., Republic, Pa., one team; Rochester & Pittsburg Coal and Iron Co., Punxsutawney, Pa., one team; Spring Valley Coal Co., Spring Valley, Ill., one team; Stearns Coal and Lumber Co., Stearns, Ky., one team; Sugar Creek Mining Society, Poston, Ohio, one team; Susquehanna Coal Co., Wilkes-Barre, Pa., one team; Tennessee Coal, Iron and Railway Co., Birmingham, Ala., one team; Tower-Hill Connellsville Coke Co., Uniontown, Pa., one team; Stag-Cañon Fuel Co., Dawson, N. Mex., one team.

The total number of teams engaged in the demonstration was 40, but representatives of first-aid teams from Utah, Colorado, and Wyoming were present, and every state mining coal in the United States, besides several foreign countries, had delegates who witnessed the events. To avoid any leaning toward professionalism the demonstration was not competitive.

If the event had been competitive the judges would have had an exceedingly difficult time in picking the winners

and would probably have been treated like base-ball umpires. It is probably not amiss to repeat what has been stated previously in MINES AND MINERALS, viz.: That the object of first-aid work is to relieve the injured and if possible save life by preventing hemorrhages and allaying the effects of shock following a serious accident.

Competitive contests, while having a bearing on accuracy, despatch, and neatness in dressing wounds, are locally of much interest between local companies, for which reason they should be continued.

Often life has been saved by first-aid corps who failed to take the first prize at competitive drills, which shows conclusively that the good work now being carried on is bound to save many lives in the future.

That one team is neater than another bandaging a patient until the surgeon can attend to him is due to aptitude and practice, but so long as any team learns and uses the necessary tactics to relieve the injured, the primary object is attained.

At Forbes Field odd-numbered teams were given the following problems:

1. Treat a lacerated wound on the right temple and a lacerated wound on top of the right shoulder. This was a one-man event.

3. Treat a simple fracture of the left collar bone and simple fracture of the jaw. Two-men event.

5. Treat conditions of a man who has fallen on an electric wire, back down, with clothing burning. Rescue, extinguish fire, treat back and upper arms. Team event.

7. Treat gas burns on face, neck, ears, and hands. Team event.

9. Treat a broken back and simple fracture of the right forearm. Team event.

Even-numbered teams performed the even-numbered events, thus all teams were partly or wholly engaged during the exercises.

2. Treat a punctured wound over the left eye and a lacerated wound on palm of the hand. One-man event.

4. Treat a dislocated right shoulder and a simple fracture of the right leg. This event was for two men.

6. Treat conditions of a man who has fallen on an electric wire face down. Rescue, extinguish fire, treat chest and upper arms. Team event.

8. Treat gas burns on hands, right arm, and shoulder. Team event.

10. Treat a dislocated hip and simple fracture of the collar bone. Team event.

Owing to the field being muddy, canvas was laid down for the teams, but even then conditions were more favorable for operations than in a mine where light is poor and surroundings cramped.

Frequently during the demonstrations the President and spectators applauded, and between events bands in various positions in the big stand played, Pittsburg University, Carnegie Technical School, and Duquesne University

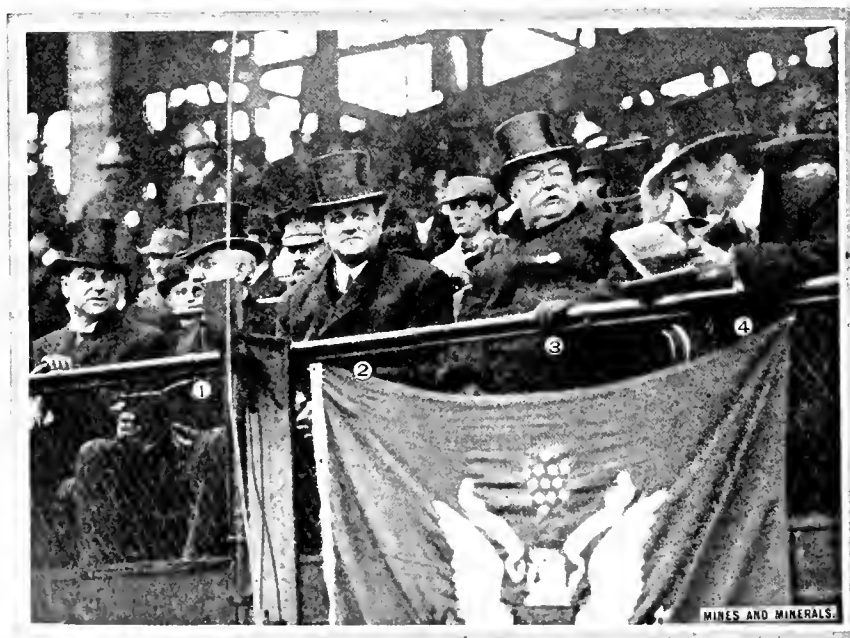

WATCHING COAL-DUST EXPLOSION AT PITTSBURG

1. A. J. Barchfield, M. C.; 2. Gov. Tener, of Pa.; 3. President W. H. Taft; 4. Dr. Jos. A. Holmes

students cheered, so that there was action at all times to keep the minds of those in the boxes off the wet-damp.

After the team demonstrations, G. A. Burrell, of the Bureau of Mines, entered a glass box which contained $\frac{1}{4}$ of 1 per cent. of carbon monoxide, the gas termed "whitedamp"

by coal miners. He took with him three canary birds in a cage. The atmosphere was sufficiently bad in this box to overcome the birds, but not the man. Two of the birds were subsequently resuscitated by oxygen, but the writer believes the third bird failed to respond to the treatment. Directly after this demonstration President Taft pushed a button and discharged a quantity of powder which fired 153 pounds of bituminous coal dust in a steel explosion tube 150 feet long placed some distance from the stand. A rescue party made up of men from the Bureau of Mines, Illinois Mine Rescue Station, Philadelphia & Reading Coal and Iron Co., Pittsburg-Buffalo Co., and other local coal companies, wearing rescue apparatus, then entered the gallery and recovered five supposed victims of the mine explosion. A squad of foremen and first-aid men of the Bureau of Mines demonstrated first-aid treatment, using the pocket first-aid packet and such things as might be handy in a mine. C. O. Roberts treated a miner overcome by afterdamp and having a scalp wound. W. A. Radenbush and William Burke treated a patient slightly overcome by afterdamp and suffering from a simple fracture of the right thigh and compound fracture of the right forearm near the wrist. W. D. Roberts and J. T. Ryan treated a man overcome by afterdamp and suffering from simple fracture of right collar bone and simple fracture of left arm. W. A. Radenbush and William Burke treated a miner overcome by afterdamp and burned about face, neck, ears, and hands. W. D. Roberts, C. O. Roberts, and J. T. Ryan looked after a miner overcome by afterdamp and burned from the waist up.

Governor J. K. Tener then delivered an address, introducing Secretary of the Interior Walter L. Fisher, who said among other things: "This question of conservation is not a matter of sentiment; the demonstration here today proved that conclusively. The greatest waste, however, is the waste of human life, and my official duty is to further this great movement for the conservation of life in every possible way."

Governor Tener next introduced Miss Boardman, head of the American National Red Cross Society, who delivered an interesting address in which she said: "The fact that 2,000 lives are lost annually in our mines is an appalling national disaster. It is not enough to provide pensions for miners' widows and their families, provisions must be taken to guard against and prevent accidents in mines as much as possible. I take this occasion to ask the hearty and material cooperation of everybody with the Red Cross Society in the work for the conservation of human life."

As a matter of form, Governor Tener, the chief executive of the largest and wealthiest coal-producing state in the Union, introduced the chief executive of the United States, who after



STEEL GALLERY AFTER EXPLOSION OF COAL DUST

of the mining industry thrives, that this demonstration should be held.

"There are 300,000 miners and their families in Pennsylvania. There are 700,000 in the United States. In the last 20 years 30,000 men have lost their lives in the mines and 70,000 have been injured.

"That is not a record to be proud of. It is time indeed that we should take steps to restrain this great loss.

"The federal government has no direct jurisdiction, but it has the money and the authority under the Constitution to act at all times for the general welfare of the people.

"This loss of life must be brought home and emphasized on the miner himself. We are a great nation, we know it, because we admit it. (Laughter.) We have certain defects, however, and one is a security that we are not going to be hurt.

"We must overcome that idea and we must take more precautions to save life. This requires discipline, instruction, and experience.

"We must enforce these ideas so that the miners themselves must save themselves by strict attention to the instructions that must be given in turn by government and state.

"I do not know of an occasion that is more important for the development of industry than this right here today, in this hive of industry.

"We must stamp out the spirit of carelessness, the happy-go-lucky idea, which I fear prevails among American citizens generally.

"We can say such a thing about ourselves even if we would not allow any others to say it.

"It has been an inspiring sight to see these men enter that hole yonder to save a life."

The President then presented prizes to all the first-aid teams taking part in the demonstration as they paraded past the stand.

The awards consisted of medals given by the American Red Cross Society and first-aid kits by J. H. Hammond. Each first-aid corps was given an elaborate silk banner on which in gilt letters was the name and address of the coal company represented.

These banners, souvenir admission badges, and miscellaneous items were donated by the Pittsburg Coal Operators' Association.

As the last miner passed the stand the Chief Executive and party walked off the field, the bands played, and the thousands of spectators dispersed, satisfied that they never had seen an exhibition so unique and so fraught with importance to the conservation of mankind.

The officers in charge of the demonstration were J. W. Paul, manager of field events; Dr. M. J. Shields, manager of first-aid events; Clarence Hall, manager of explosion; Francis Feehan, field marshal; and J. K. Clement, chief usher.



RESCUE TEAM ENTERING GALLERY AFTER EXPLOSION

Overhead Electrical Practice in Mines

Design, Construction and Installation that Greatly Affect the Economy of Operation

The following paper, by G. H. Bolus, is reprinted by permission of the Ohio Brass Co. Bulletin:

While much has been written about the behavior or performance of electrical apparatus in mines, covering various kinds and types of motors, locomotives, etc., the overhead electrical circuit seems to have received very little consideration.

In practically all of the coal mines and some of the metal mines in the United States, direct current is used with a range in voltage of from 220 to 250. Some mines in West Virginia employ the three-wire system with 500 volts between outside wires and 250 volts between outside and neutral. There are also some alternating-current installations in use in mines, but generally speaking, it may be said that the alternating current is not as much used as direct current.

In the transmission of electrical energy, it is a generally accepted rule to limit the range of distribution to 1 mile for 250 volts and 4 miles for 500 volts. Unfortunately, in mines

farther back into the seam, the mine manager finds it necessary to install more feeder in order to get the proper response from his cutting machines and locomotives. Another thing which has been the cause of considerable bad installation work in mines has been the scarcity of good workmen, proper tools, and properly designed material.

The subject of the proper percentage loss of voltage in mine circuits is a much mooted one, but, generally speaking, the writer has found that a loss of from 15 to 20 per cent. at maximum load is permissible.

Regarding the proportioning of the carrying capacity of feeders, it has been found that if the feeder is laid out to carry 60 per cent. of the total current used in a mine, the operation will be satisfactory, as it is rarely the case that all machines are operating continuously at one time, and even should this condition occur, it would only be for a short time.

LOSS OF VOLTAGE IN MINES (Two-Wire System)
250 VOLTS OF MINE ENTRANCE. TRACK RESISTANCE EQUAL TO OVERHEAD RESISTANCE. 100 AMPERES IN CIRCUIT

Distance in Mine in Feet	Volts Loss			Volts Between Track and Trolley		
	One 4-0 Trolley Only	One 4-0 Trolley and One 4-0 Feeder	One 4-0 Trolley and Two 4-0 Feeders	One 4-0 Trolley Only	One 4-0 Trolley and One 4-0 Feeder	One 4-0 Trolley and Two 4-0 Feeders
1,000	10	5	3	240	245	247
2,000	19	10	6	231	240	244
3,000	29	14	10	221	236	240
4,000	39	19	13	211	231	237
5,000	49	24	16	201	226	234
6,000	59	29	20	191	221	230
7,000	68	34	23	182	216	227
8,000	78	39	26	172	211	224
9,000	88	44	29	162	206	221
10,000	98	48	33	152	201	218
12,000	117	59	39	133	191	211
15,000	146	73	49	104	177	201

TO FIND VOLTS AT ANY OTHER CURRENT.—Divide current in amperes by 100 and multiply the result by the volts loss in Table.

EXAMPLE.—Required, voltage between trolley and track, in a mine using 4-0 trolley and one 4-0 feeder at a point 3,000 feet from mine entrance. Current 500 amperes.

SOLUTION.—Volts loss with 4-0 trolley and 4-0 feeder at 3,000 feet=14. 500 amperes divided by 100 equals 5. 5 multiplied by 14 equals 70=volts loss. 250 volts at mine entrance minus 70 volts loss equals 180 volts between trolley and track=ANSWER.

To find loss in mine using 3-0 trolley or feeder, multiply volts loss in Table by 1.261.

To find loss in mine using 2-0 trolley or feeder, multiply volts loss in Table by 1.509.

EXAMPLE.—Required, voltage in mine using 3-0 trolley and two 3-0 feeders, at a point 5,000 feet from the mine entrance, current 100 amperes.

SOLUTION.—Look in Table and find under one 4-0 trolley and two 4-0 feeders, and opposite 5,000 feet the loss to be 16 volts. Multiply 16 by 1.261 which gives 20 volts. 250 volts minus 20 volts=230 volts=ANSWER.

To find current taken by a 250-volt motor, multiply the horsepower by three.

To find current taken by a 500-volt motor, multiply the horsepower by one and one-half.

The table herewith gives the approximate drop in voltage of a 250-volt two-wire system with conditions of trolley and feeder as ordinarily encountered in the average coal mine.

It would be extremely difficult to lay down rules for the installation of the overhead circuit in all mines, but the following rules, if carried out, will materially increase the efficiency of the electrical circuit.

A. Install all mine wiring for power on approved porcelain or glass insulators with steel or wood pins as a support. They should be placed as often as 20 feet for low roof and not to exceed 35 feet for high roof. Porcelain insulators, if thoroughly vitrified, are to be preferred to glass.

B. Install only one wire on each insulator, securely tying it to the insulator with a tie wire, preferably of the same material as the conductor. This would not, of course, apply to lead-covered conductors. Tie wire should be preferably No. 4 wire.

C. Install all trolley-wire hangers practically at the same height from the top of the rails, so as to bring the trolley wire as nearly on a level as possible. This will eliminate jumping of the trolley wheel and also arcing to a certain extent. The center of each hanger should be plumbed a certain distance outside the outer edge of track rail. This distance is governed by the mining laws of different states, and also by the size and type of locomotive used.

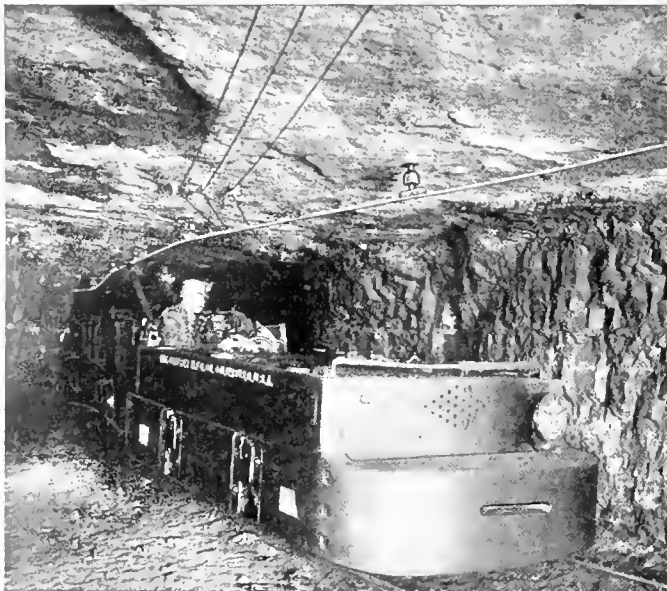

FIG. 1. EXAMPLE OF GOOD OVERHEAD CONSTRUCTION IN MINES

it is frequently necessary to carry electric power into a mine using 250-volt service, for a greater distance than 1 mile, and this calls for a correspondingly greater outlay for feeders. Beyond these distances, where conditions will permit, it is advisable to use alternating current of higher potential, and transmit the power by means of a high-voltage transmission line. Single-phase motors are not adapted to mine service and for this reason polyphase systems are much preferred.

Electrical apparatus and fittings for use underground are subjected to the destructive action of acid-laden mine waters and excessive dampness, and they are, therefore, designed to take care of this condition; but even with all the precautions taken in the design of a piece of apparatus or fitting, it may still prove inefficient if it is improperly installed. It seems to have been the tendency in past years for one mining company to follow the rules of its neighbor in laying out the electrical circuits, with little or no information as to whether the neighbor was right or wrong. The result is that many mine managers are now awakening to the fact that their electrical circuits are inadequate for the service required.

The temporary manner in which new operations are supplied with power transmission is frequently the cause of insufficient feeder wire being installed, and as the workings progress

The severest stress which can be placed upon a hanger, and especially upon the insulation, is that encountered on a curve, and in railway practice pull-offs are used to take care of the strain on the curve, but as railway pull-offs are not practical in mines (especially in the low-veined type), a sufficient number of hangers should be installed on the curve to prevent the studs of the hangers being bent and the trolley clamps from being distorted. No fixed rule can be laid down for this as it depends entirely on the strains induced by the trolley wire and the degree of the curve; but, generally speaking, hangers should be placed from 6 to 10 feet apart on curves. For curve work, it is good practice to use a clamp in which the boss comes tightly against the insulation when the clamp is lined up. This will prevent, to a certain extent, bending of the stud (see Fig. 4). Where pull-offs can be used they should be guyed with No. 6 galvanized-steel wire and should have a conical strain insulator cut in the wire. Timber hangers, as the name would imply, are designed to be attached directly to mine timbers but in a large number of mines it has been the custom to attach the timber hangers directly to the mine roof, either by means of suitable expansion bolts or wooden plugs driven into holes in the roof, and the hanger installed by means of lag bolts. This practice is not so good as if installed on a timber or a small block, still it has proven satisfactory in service. The insulation resistance of the hanger is the same as that of an expansion-bolt hanger, and, consequently, leakage would be the same.

Expansion-bolt hangers are provided with a boss into which the end of the expansion bolt may be screwed. The hanger is usually provided with a hexagonal body so that a wrench may be applied. Spikes and nails should not be used for attaching hangers of any kind to their supports. Steel mine timbers are rapidly coming into use for timbering main entries, and a very good installation of trolley and feeder may be made by fastening the hangers directly to the bottom of the I beams. Clamps for fastening the hanger to the I beams are now being placed on the market.

D. The subject of proper placing of a trolley frog or switch pan, as it is sometimes called, has frequently been brought to the writer's attention, and on account of various sizes of locomotives used, it is a rather difficult matter to determine. Circular No. 23 of the Bureau of Standards recommends that frogs be placed 10 to 12 feet back from point of latch and held in horizontal position by properly placing hangers on the line near frogs. It has been the writer's experience that the distance specified will be satisfactory for most of the conditions encountered in mines.

Trolley frogs are provided as a rule with four pull-off rings or eyes, so that they may be guyed to the proper position by the use of guy wires. Never attach a guy wire on a frog or any other trolley device which is to carry current, without cutting in a conical strain insulator in the guy, which will properly insulate it. Frogs should always be placed on branches leaving main trolley.

Malleable iron trolley frogs are now making their appearance upon the market and can be used to advantage in mine service.

E. When dead-ending trolley wire, it should be securely anchored and insulated, either by use of a conical strain insulator and ordinary turnbuckle, or a Brooklyn strain insulator, which is really a combination of the above two mentioned, or other suitable insulator. A suitable galvanized clamp should be used for holding the dead-end loop at the end of the trolley wire (see Fig. 3).

F. Allow proper clearances in all cases for the trolley wheel. It is extremely bad practice to allow the wheel to touch the roof, even though the roof may be hard sandstone or other formation, as it increases wear on the wheel and is generally unsatisfactory. It is better to install more hangers where the trolley touches the roof; that is, install them so that they will come closer together. It is still better to shoot down

a little of the top and get the proper clearance, where conditions will permit.

G. The manner of making the proper connection at a point where a feeder is to be tapped into the trolley wire, should receive careful consideration. The practice of hooking feeders around the trolley clamps should not be permitted, as they invariably work loose and cause trouble. A high resistance will generate considerable heat and will produce a very vicious arc which will probably burn off the feeder. It is recommended that a good form of feeder ear or clamp be employed, and where the feeder is of such size that it will not fit the ear, two or even three ears should be installed at that point and suitable taps run from the feeder proper to the ears (see Fig. 5). The total area of copper in circular mils in the taps should be equal to the area in circular mils of the cable. Feed-in yokes, made especially for feeding in purposes, may be purchased in the market and will be found satisfactory for this purpose.

H. The selection of a proper trolley clamp is a matter that should receive proper consideration. Clamps have been designed which are too long and which, when the hanger is installed slightly out of plumb, produce a bump or projection in the trolley wire which invariably causes arcing as the trolley



FIG. 2. SHOWING UNEVEN TROLLEY WIRE CAUSED BY HANGER BEING OUT OF PLUMB

wheel passes the clamp (see Fig. 5). The clamp should be narrow so that the wheel will pass it without striking, and the nut or other clamping means should be located high enough on the clamp proper so as not to strike a badly worn trolley wheel. A great deal of the sparking of the trolley at hanger points could be eliminated by the use of a well-designed clamp and keeping the hangers carefully plumb.

I. Splices in the electrical circuit should be made with care, as it is astonishing to observe the drop in voltage caused from poorly made joints. Splices in the trolley circuit may be made by suitable splicers designed for this purpose, and may be either soldered or mechanical. Splices in feeders should be made by the use of a good splicer and may be either of the soldered or mechanical type.

It is known that where two dissimilar metals are joined together, as would be the case where two copper wires were joined by means of a soldered connector, that due to the excessively moist atmosphere there will be set up a local electrolytic action which in time will destroy the joint. A remedy for this is to simply tape the joint so that it will be protected from the moisture.

J. Section insulators for sectionalizing the trolley circuit may be purchased in the market and they should be installed

insulators to prevent their wobbling when the trolley wheel passes over them. It is generally considered good practice to install a section insulator on a hanger. They may also

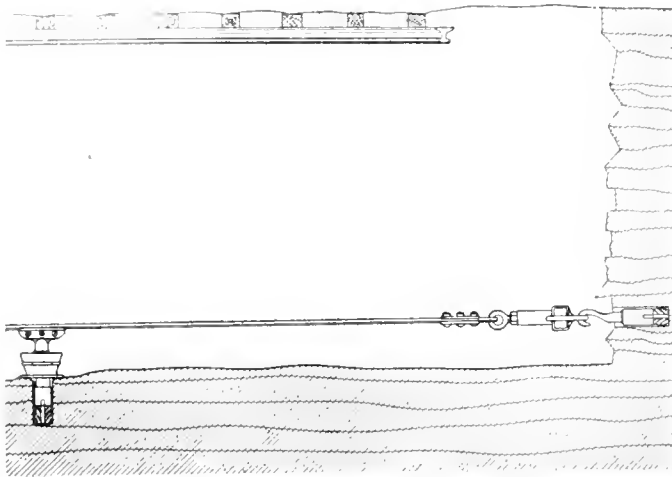

FIG. 3. APPROVED METHOD OF DEAD ENDING TROLLEY WIRE

be supported by hangers installed a short distance on each side of the insulator.

Section insulators are of three general kinds: the ordinary, automatic, and hand operated. The ordinary type of section insulator is used where it is desired simply to sectionalize the trolley, as, for instance, in a case where one feeder would feed one section of trolley and another feeder another section of trolley. There is no means provided for connecting the two sections of trolley together, except by the use of a jumper in an emergency.

The automatic section insulator is designed with a rocker arm so placed that the action of the trolley wheel in passing under the section insulator will cut in a section of trolley wire ahead of the locomotive. They have operated satisfactorily, but are open to the objection that they frequently get out of order and the movable parts give trouble.

The section insulator with switch is an ordinary section insulator with a knife switch placed on one side. The handle of the switch is brought out at an angle of about 45 degrees and is so placed that the locomotive driver in passing under the section insulator may throw the switch. It has the advantage of few working parts, very rugged construction, and light weight.

K. In wiring entries where a grounded circuit is used, care should be taken to install the positive or hot wire next to the rib, with the negative or cold wire installed 10 inches on the outside of the hot wire.

No electrical conductors of any kind should be installed in mines unless they are put on suitable insulators or hangers. This, of course, would not apply to cases where conduit is used, but this latter condition is rather rare.

The installation of incandescent lamps in a mine should

be done as thoroughly as that employed in house wiring. The practice of soldering a wire to the base of a lamp and hooking the other end across the circuit should be discontinued. Special precautions should be taken in gaseous mines to enclose all incandescent lamps in air-tight globes. The rules covering this will be found in the mining laws of various states.

L. Whenever there is danger of the wires being touched, as, for example, where they cross an entry, they should be protected either by trenching the roof or other suitable means. If trenches are used they should then be covered by 1-inch boards fastened by wooden pegs or other means. The wires must not touch the roof but must be thoroughly insulated and well separated from it.

It should be understood that the above suggestions are for the average conditions encountered in a mine. Special conditions, of course, would require special treatment and cannot be covered here.

Appreciating that the lack of a good simple formula for determining the amount of feeder necessary to handle any installation is quite keenly felt, a formula which is quite generally accepted is given below:

We will take a concrete example:

Required size of feeder to transmit 300 amperes, total distance from power house to center of distribution 3,000 feet, 15 per cent. allowable drop in voltage. From formula,

$$C M = \frac{22D \times I \times I}{L}$$

we have the following, where D = the distance in feet, I = current, and L = voltage loss, 22 is a constant:

$$L = 15\% \text{ of } 250 = 37\frac{1}{2} \text{ volts}$$

$$C M = \frac{22 \times 3,000 \times 300}{37\frac{1}{2}} = \frac{19,800,000}{37\frac{1}{2}} = 528,000 \text{ C. M.}$$

In practice, a 500,000 C. M. cable would probably be installed, or, under some conditions, a 4-0 feeder and a 4-0 trolley could be tied together and used to take care of this condition, although not quite up to the required area. In these calculations, it is assumed in all cases that the track

return resistance is equal to the trolley resistance, as this is the most economical condition for the transmission of power using the track return. The subject of the proper care and maintenance of the track return circuit is intimately connected with

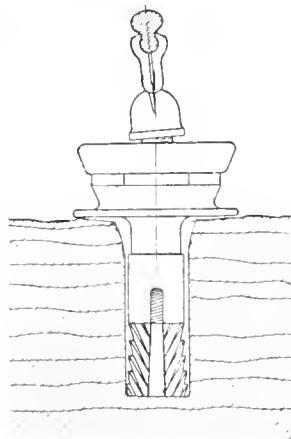

FIG. 4. BENDING OF STUD ON CLAMP DUE TO CLAMP NOT BEING SCREWED UP TIGHT AGAINST THE HANGER

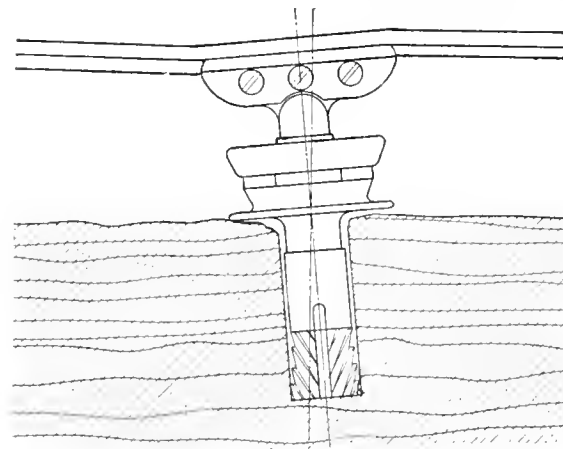

FIG. 5. EFFECT ON TROLLEY WIRE OF INSTALLING HANGER OUT OF PLUMB

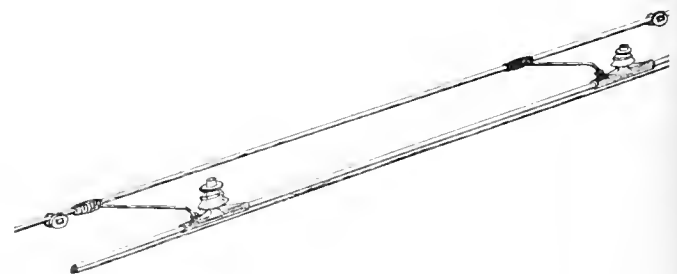

FIG. 6. METHOD OF CONNECTING FEEDER WIRE TO THE TROLLEY BY MEANS OF TWO OR MORE TAPS TO OBTAIN FULL CAPACITY OF FEEDER WIRE

that of the overhead construction, as if it is not properly attended to, much of the advantage of the good construction overhead may be neutralized.

Turbine Mine Pumps

Experience in Pumping With Turbine Pumps Compared With Ordinary Steam Pumps

When dealing with machines for unwatering mines the term efficiency may or may not mean the power of producing effects continuously. It would seem therefore that the phrase economical efficiency is the more appropriate.

When water buckets such as those at the Hampton colliery of the Delaware, Lackawanna & Western Coal Co. produce an efficiency of over 80 per cent, and compound steam pumps an efficiency of 70 per cent, while an electrically driven turbine furnishes an efficiency of about 60 per cent, it would naturally appear as if every mine should be equipped with water buckets. At a depth of 500 feet water buckets are probably the most efficient unwatering devices, and, provided they are automatic in action and do not require the services of an engineer, most economically efficient; but the expense of installation, if shafts must be sunk purposely for them, may make the first cost so excessive as to preclude their use. If this be the case the next most efficient machine, theoretically, is the compound mine pump, yet the conditions of pumping may be such that the first cost with subsequent repairs and attendance will be so great that the economical efficiency will not compare favorably with the turbine. In the use of the electrically driven turbine, or centrifugal stage pump, difficulties may be encountered which will render it less economically efficient than a plunger pump working expansively. When conditions under which pumps must work vary as they do in the anthracite fields, it is not uncommon to find the same companies using all three devices mentioned. With gritty acid water the pump most in favor seems to be the turbine, but where the water is clean and clear the compound steam pump is ordered, and where the lift is over 500 feet and there is a central drainage for several mines some of the large anthracite companies use water buckets.

The impression pretty generally prevails that anthracite mining is equivalent to Calumet & Hecla copper mining, when, as a matter of fact the margin of profit is smaller generally than in bituminous mining, owing to the large amount of money invested and the greater expense for timber and working.

The Lackawanna field is probably the most favored by nature for cheap mining, but in this field from 12 to 16 tons of water must be lifted to the surface for each ton of coal mined, and since anywhere from \$10,000 to \$50,000 is involved in the installation of a pumping plant, not to mention auxiliary pumps, a great many thousand tons of coal must be mined before the pumps have paid for themselves. It is no wonder therefore, when the purchase of a pump involves both theoretical and practical conditions, that the theoretical efficiency must in some cases at least be neglected for the more economical practical results.

There is no question but that the turbine pump is in many respects ideal for mine work, and that since its introduction in

the anthracite fields it has been greatly improved, however, there is still room for improvement. During the short time it has been in service it has been improved to a greater degree than any plunger pump in the same period, for which reason it is probable that its theoretical efficiency will be increased.

All the large anthracite companies have installed these pumps, and the Delaware, Lackawanna & Western uses them attached to small steam turbines as boiler feed-pumps.

In 1905 A. B. Jennings, now vice-president of the Jeanesville Iron Works, canvassed the anthracite fields of Pennsylvania in the interest of the Worthington Steam Pump Co. The introduction of electrically driven turbine pumps into these fields was due to his endeavors, and an official report of their work has been looked forward to with considerable interest. The first of these pumps installed was intended as a supplementary pump to aid two 20" x 9" x 38" direct-acting steam pumps in time of floods.

At first considerable trouble was experienced by the thrust due to the pressure of water coming direct on the end of the journal shaft. This was eventually overcome, however, by making use of the slotted bruses and shaft end previously adopted in marine work, and shown in Fig. 1

No trouble has been experienced with these thrust boxes so long as they have been kept properly lubricated, and as there is an automatically worked sight feed-lubricator, only extreme carelessness on the part of the pumpman in not supplying oil can produce a hot box.

The first difficulty being overcome, attention was next directed to the wear on the impeller blades. The conditions at anthracite collieries are unusually severe on pumps, the water being acid usually, and in addition fine grit finds its way into the sump, particularly during the thaws at the breaking up of winter or after a series of abundant rains. The speed of an 18-inch diameter impeller wheel being about

4,700 feet per minute, the grit in the water traveling at this speed obtains sufficient momentum to wear away the impeller blades and tips of the diffusion vanes unless those parts are constructed of suitable metal to resist the abrasion. It appears that the difficulty in finding a non-corrosive metal to withstand the acid water was not so great as to find a hard non-corrosive metal that would withstand abrasion from the grit. After experimenting with a number of alloys one was found that answers fairly well for fine grit

To determine the cost of electric current for pumping any number of gallons of water per day, it is necessary to know the cost (c) of the current per kilowatt hour (K. W.) the efficiency of the motor (e_m), mechanical efficiency of the pump (e_p), and the height (h) to which the water is pumped. Since 1.34 horsepower = 1 kilowatt; 8.334 pounds = weight 1 gallon of water; and 33,000 foot pounds = 1 horsepower.

$$\text{Cost} = 24 \times c \times \frac{\text{gals. per min.} \times 8.334 \times h}{1.34 \times e_m \times e_p \times 33,000}$$

That turbine mine pumps are appreciated can be understood when in the space of a few years one large company ordered about 60 and another between 20 and 30.

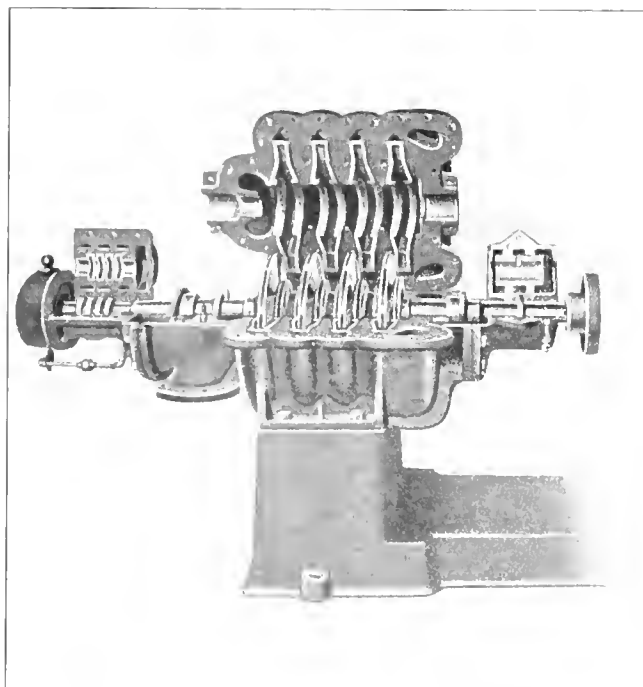

FIG. 1. DOUBLE-SUCTION TURBINE PUMP, CASING OPEN

Coal Mining Notes

Coal Mining in Kentucky.—Kentucky is one of the leading coal-mining states. Of the total output of coal in the United States 12 per cent. was cut by machine. The amount so mined was as follows:

District	Machine Mined Tons	Per Cent. of Total Production
Western	6,258,184	74.26
Southeastern	1,544,241	36.30
Northeastern	1,351,661	66.34
	9,154,086	62.18

The figures for the western district shows a gain of 1,812,914 in the machine-mined tonnage over that for 1909, but a decrease of 5.43 in the percentage. The Southeastern district shows an increase of 531,858 in the tonnage, and an increase of 9 in the percentage. The Northeastern district shows a gain of 706,453 in tonnage, and of 19.45 in percentage.

Coal Mine Arbitration.—A joint interstate agreement was entered into between the operators and miners for the states of Missouri, Arkansas, Kansas, and Oklahoma on September 18, 1910, and will end March 31, 1912. Under this contract W. L. A. Johnson was elected arbitrator and has the sole power of deciding all cases of dispute arising under the contract with certain limitations.

It has always been my opinion that arbitration and an arbitrator is a step in the right direction, and so far the arbitrator has decided a great many cases of dispute and the men have continued at work. Some cases decided by him have not been altogether satisfactory to the operators, and we would judge that the same is true with the miners, but on the whole I am frank to admit that I think an arbitrator is a good thing and has resulted in much benefit to both parties.—J. E.

New Mexico Coal and Coke.—The demand for coal and coke of New Mexico mines was restricted in 1911 by reason of the revolution in Mexico practically closing the market during the first 9 months. Railroad operation was almost entirely suspended and no coal used on the railroads, and as a consequence coal and coke could not be transported to the mines and smelters. The shipments of ore to the smelters in the United States were also suspended, lessening the demand for coal and coke at the smelters on this side of the line. The stagnation of the copper market also had a restraining influence on the demand for New Mexico coal and coke. With the restoration of normal conditions in Mexico that market will again be opened to the products of the New Mexico coal mines, which, together with the demand for the winter supplies in the domestic markets of the Pacific coast states will furnish a demand for the full production of the mines during the balance of the year.

The general depression in business conditions has been felt but little in the coal mine operations of the territory, and had it not been for the revolution in Mexico it is quite certain New Mexico's increase of production of coal and coke would have been greater than in any preceding year.

Coal in Indiana. The coal output in Indiana for 1911 is going to be considerably less than in 1910, which was the banner year for the state. In that year an early agreement was reached by the miners and operators, and the strike in Illinois, together with the general demand for coal, greatly increased the output over the normal.

Coke-Making Record. The Pocahontas coal mined at Gary, W. Va., carries only about 17 per cent. of volatile matter, and although it will coke in beehive ovens it does so at the expense of the fixed carbon. The steel corporation, therefore,

ships the coal to Joliet, Ill., and Gary, Ind., where it is mixed with 20 per cent. of Illinois coal and then coked in Koppers by-product ovens. The Illinois coal does not coke by itself, and the Pocahontas coal swells considerably by itself, but the mixture works together so well that 84 per cent. of coke is obtained. This is probably a record for coke making from coal of any description.

Scranton District Mining Institute Banquet.—The third annual banquet of the Scranton District Mining Institute was held in the Thirteenth Regiment Armory, Scranton, Pa., October 21. In point of numbers—1,600—it was the largest banquet ever held in Scranton. Almost every class connected with the anthracite mining industry was present, and in this respect the affair was extremely democratic. This institute was organized in January, 1908, with a membership of 120. At present it has a membership of 1,756. The membership is made up of 849 miners, 180 mine laborers, 152 fire bosses, and assistant foremen, 16 superintendents, 77 foremen; the balance being made up of managers, clerks, mining engineers, etc. C. E. Tobey, assistant coal mine manager of the D., L. & W., is president of the institute, and his speech on the history and objects of the institute was exceedingly interesting.

Electrically Operated Cautionary Signals in Coal Mines. W. J. Murray, vice-president and general manager of the Victor-American Fuel Co., has recently introduced at his mines at Hastings and Delagua, Colo., an electrically operated cautionary signal which should prove of service to others. The device consists essentially of the ordinary "flash" sign familiar in street advertising. The warning, "Always be careful," as shown below is cut from a steel plate (to prevent possible breakage) in letters 3 inches high and in five languages:

ALWAYS BE CAREFUL
BODITE VEDNO PAZLJIVI
PAZPR PRI RADU
STATE SEMPRE ATTENTI
VAZDA SE CUVAJTE

This plate is placed over an ordinary glass-faced box, 20 in. × 24 in. in size. Within the box are four electric lamps operated by a 250-volt D C current from the mining machine feed-wires. The first warning sign is some 100 feet within the manway and others are placed throughout the mine at points where they will attract the most attention. As arranged at these mines, the light is "on" for 1½ seconds and "off" from 6 to 8 seconds.

Explosion of Powder at O'Gara Mine.—What is said to have been an explosion of powder in mine No. 9 of the O'Gara Coal Co., 1 mile from Harrisburg, Ill., occurred October 23. It is not known definitely just what caused the explosion, but it is presumed that it was due to an electric wire coming in contact with some loose powder in some way not known, because the explosion tore down the wires in the vicinity. Eight miners were killed by this explosion, and eight others were rendered unconscious, but were removed from the mines by rescuers. Dr. C. W. Turner and two others were overcome by gas, and for a time their condition was serious, but medical treatment at the hospital resuscitated them.—C. T. H.

The Study of Knots.—More than 50 of the students of the Massachusetts Institute of Technology have applied for instruction in the new course in knots and splices that Major E. T. Cole is to provide. It seems an odd study for a man whose profession is to be exercised on land, but an engineer must be able to solve all sorts of problems, and there is little in the way of practical education from lighting a fire to tight-rope walking that will not be of service to him. The need of windings and knots in scaffolding, shears, and the like is too evident to require argument. The *Tech*, the college paper, characterized the study as "A knotty-cal course."

Answers to Examination Questions

Selected Questions of the Illinois Examinations Held at Springfield, 1910

NOTE.—The questions selected are here numbered consecutively. The date of the examination and the true number of the question is given at the end of each question. M = mine managers examination; E. = mine examiners

QUES. 1.—With 52 horsepower an air-current of 120,000 cubic feet per minute is produced; how many cubic feet per minute will be produced with 44 horsepower? M., Apr. 11, Q. 3

Ans.—For the same mine or airway, the quantity of air in circulation will vary as the cube root of the power; or, in other words, the quantity ratio is equal to the cube root of the power ratio. Therefore, calling the required quantity of air x , we have,

$$\frac{x}{120,000} = \sqrt[3]{\frac{44}{52}} = \sqrt[3]{846153+} = 94584$$

$$x = 120,000 \times 94584 = 113,500 \text{ cu. ft. per min.}$$

QUES. 2.—If 2 horsepower will produce 10,000 cubic feet of air per minute in single airway 10 ft. × 10 ft.; what horsepower will be required to produce the same amount of air in three airways, each airway being 6 ft. × 5.5 ft. and of the same length as the single airway? M., Apr. 11, Q. 4

Ans.—The formula expressing the work or power in terms of the dimensions of the airway is

$$u = \frac{k l o q^3}{a^3}$$

Since, in comparing these two circulations, k , l , and q are constant, or the same in each case, it is easy to observe that u varies as the expression $\frac{o}{a^3}$; or, in other words, the power varies directly as the perimeter and inversely as the cube of the area. Hence, the power ratio, in this case, is equal to the perimeter ratio multiplied by the cube of the inverse area ratio. For the single airway, $o = 4 \times 10 = 40$ feet; $a = 10 \times 10 = 100$ square feet. For the three airways together $o = 3 \times 2 (6 + 5.5) = 69$ feet; $a = 3 (6 \times 5.5) = 99$ square feet. Then, calling the required power x ,

$$\frac{x}{2} = \frac{69}{40} \times \left(\frac{100}{99}\right)^3 = 1.778$$

$$x = 2 \times 1.778 = \text{say, } 3.5 \text{ H. P.}$$

QUES. 3.—What load will break a white-oak timber 10 in. × 12 in. and 15 feet between supports? The load is to be equally distributed along the length of the timber

M., Apr. 11, Q. 7

Ans.—The breaking load for a rectangular beam is found by multiplying the breadth of the beam in inches by the square of the depth in inches, and dividing that product by the distance between supports in feet; then multiply this quotient by one-ninth of the ultimate fiber stress (white oak = 8,500 pounds per square inch) to obtain the breaking load when uniformly distributed. Thus, in this case,

$$\text{Breaking load} = \frac{8,500 \times 10 \times 12^2}{9 \times 15} = 90,666 \text{ lb., say } 45 \text{ tons}$$

QUES. 4.—Give the breaking strain of a $\frac{3}{16}$ -inch, crucible-steel, hoisting rope having 6 strands of 19 wires each. Also give the safe working load for this rope. M., Apr. 11, Q. 8

Ans.—To find the breaking strain in tons, of a crucible-steel, 6-strand, 19-wire, hoisting rope, multiply the square of the diameter of the rope, in inches by 39; because 39 tons is the breaking strain of such a rope, 1 inch in diameter, and the strength of the rope increases as the square of the diameter of the rope increases. Thus, for a $\frac{3}{16}$ -inch rope,

$$\text{breaking strain} = 39 \left(\frac{3}{16}\right)^2 = 12.34 \text{ tons}$$

The safe working load for wire ropes is generally taken, in practice, as one-fifth of the breaking strain, except in special cases of deep hoisting where the factor of safety is generally increased. In this case, the safe working load may be taken as, say 2.5 tons.

QUES. 5.—How many horsepower will it take to haul 25 loaded cars up an incline 500 feet long, in 1 minute, each loaded car weighing 4,000 pounds, allowing 20 per cent. for the resistance of rope and pulleys; the grade of the slope being 10 per cent.? M., Apr. 11, Q. 10

$$\text{Ans.—The weight of the loaded trip is } \frac{25 \times 4,000}{2,000} = 50 \text{ tons.}$$

To this must be added the weight of the rope. The diameter of extra-strong cast-steel, 6-strand, 7-wire, haulage rope required for this work, using a factor of safety 5, is

$$d = \sqrt[3]{\frac{5 \times 50 \times .25}{1.58 \times 5 \times 500 \times .25}} = 1.3 \text{ say } 1\frac{3}{8} \text{ in.}$$

The weight of a $1\frac{3}{8}$ -inch rope 500 feet long is $500 \times 1.58 \times (1\frac{3}{8})^2 = \text{say } 1,500 \text{ lb.}$

The total load hoisted when the trip starts from the foot of the incline is $50 \times 2,000 + 1,500 = 101,500$ pounds. The gravity pull of this load on a 10-per-cent grade is $101,500 \times .1 = 10,150$ pounds. To this must be added the friction pull of the loaded trip, which is $\frac{1}{10} (50 \times 2,000) = 2,500$ pounds, making in all $10,150 + 2,500 = 12,650$. Then, allowing 20 per cent. for the resistance of rope and pulleys (friction), we have for the gross load on the rope $12,650 \times 80 = 15,812.5$. If this load is to be hauled up the slope in 1 minute (60 sec.) it may be assumed for the purpose of calculation that 10 seconds are consumed in starting and stopping each trip, and that it would require only 50 seconds to haul the load 500 feet at the full maximum speed of winding, which would give a maximum required speed of 10 feet a second or 600 feet per minute. Finally, taking the efficiency of the haulage engine as 85 per cent., the indicated horsepower of the engine required for this hoist is

$$\text{I. H. P.} = \frac{15,812.5 \times 600}{85 \times 33,000} = 338 +, \text{ say } 350 \text{ H. P.}$$

QUES. 6.—The temperature of the air in the downcast shaft of a certain mine is 60° F., and in the upcast 100° F., the quantity of air entering the mine by the downcast is 20,000 cubic feet per minute; each shaft is 15 feet in diameter. What will be the velocity of the air passing in each shaft, in feet per minute? M., Apr. 11, Q. 12

Ans.—The sectional area of each shaft is $.7854 \times 15^2 = 176.7+$ square feet. The velocity of air in the downcast is $20,000 \div 176.7 = 113.18$ feet per minute. Assuming there is no increase of the air-current from the addition of mine gases or otherwise, the volume of the return current, and (for the same area) the velocity is proportional to the absolute temperature. The velocity of air in the upcast is therefore,

$$113.18 \times \frac{460 + 100}{460 + 60} = 121.89 \text{ ft. per min.}$$

QUES. 7.—A pair of entries 300 feet long have five cross-cuts connecting them, at 60 feet apart; the pillar between the entries is 30 feet wide. These entries and cross-cuts are all filled with marsh gas (CH_4). If an air-current of 6,000 feet per minute is available, what is the least time that will be required to clear out this gas without fouling the air-current further than to cause a small cap on a safety lamp? All the places mentioned are 8 feet wide and 5 feet high. M., Apr. 11, Q. 13

Ans.—The entire length of entries and cross-cuts is $2 \times 300 + 5 \times 30 = 750$ feet; the sectional area being $5 \times 8 = 40$ square feet; the volume of gas filling this space, ignoring possible stoppings in the cross-cuts, is $750 \times 40 = 30,000$ cubic feet. The first small cap on the flame of an unbonneted Davy is generally observed when the air-current contains 2.5 per cent. of gas. An air-current of 6,000 feet per minute would then

carry 150,000 cubic feet of gas. Under these conditions, it will require $30,000 \div 150 = 200$ minutes, or 3 hours, to clear the entries of gas.

Ques. 8.—A downcast shaft, in a certain mine is 600 feet deep and its temperature of 50° F.; the upcast shaft, in the same mine, is 900 feet deep and its temperature 100° F.; what water gauge should these conditions produce, the barometer being 30 inches? M., Apr. 11, Q. 14

Ans.—The motive column in terms of the upcast air is

$$M = \frac{100 - 50}{460 + 50} \times 900 = 88.23 \text{ ft.}$$

The weight of 1 cubic foot of upcast air is $\frac{1.3273 \times 30}{460 + 100} = .0711$ pounds. The pressure due to this upcast column is $88.23 \times .0711 = 6.27$, and the corresponding water gauge is $6.27 \div 5.2 = 1.2 + \text{in.}$

Ques. 9.—If 20,000 cubic feet of air is produced in an airway 8 feet wide, 4 feet high, and 3,000 feet long; how many cubic feet of air will the same power produce in three airways or splits; namely, the first airway being as given above; the second airway being 9 feet wide, 5 feet high, and 3,600 feet long; and the third airway being 10 feet wide, 6 feet high, and 4,800 feet long? M., Apr. 11, Q. 15

Ans.—This question is most readily solved by first finding the potential values for each of the splits or airways; thus,

- airway $8' \times 4'$, 3,000' long; $a = 32$; $o = 24$; $l = 3,000$
- airway $9' \times 5'$, 3,600' long; $a = 45$; $o = 28$; $l = 3,600$
- airway $10' \times 6'$, 4,800' long; $a = 60$; $o = 32$; $l = 4,800$

The lowest relative areas, perimeters, and lengths for these airways are

- 1st airway, $a = 32$; $o = 6$; $l = 5$
- 2d airway, $a = 45$; $o = 7$; $l = 6$
- 3d airway, $a = 60$; $o = 8$; $l = 8$

The relative potential values are then

$$\begin{aligned} \text{First airway, } X &= 32 \sqrt{\frac{32}{6 \times 5}} = 33.05 \\ \text{Second airway, } X &= 45 \sqrt{\frac{45}{7 \times 6}} = 46.58 \\ \text{Third airway, } X &= 60 \sqrt{\frac{60}{8 \times 8}} = 58.09 \\ \text{Sum of potentials} &\dots\dots\dots 137.72 \end{aligned}$$

The total quantity of air circulated in the three given splits by the same power that will circulate 20,000 cubic feet of air in a single airway 8 ft. \times 4 ft., 3,000 feet long, is then

$$Q = 20,000 \sqrt{\left(\frac{137.72}{33.05}\right)^2} = 51,790 \text{ cu. ft. per min.}$$

Ques. 10.—What kind and size of hoisting engines would you use to hoist 1,200 tons of coal in 8 hours from a shaft 400 feet deep? The weight of coal in each car is 3,000 pounds; the steam pressure 70 pounds per square inch. Allow 20 per cent. for the resistance of engine, ropes, and pulleys, and give time for caging the coal. M., Apr. 11, Q. 19

Ans.—Allowing, say $\frac{1}{2}$ hour each day for unavoidable delays, the actual time of hoisting is $8 \times 60 - 30 = 450$ minutes. The rate of hoisting is then $(1,200 \times 2,000) \div 450 = 5,333 + \text{pounds per minute}$. Since one car carries 3,000 pounds of coal, the time per hoist is $\frac{3,000}{5,333} \times 60 = \text{say, } 34 \text{ seconds}$. Now, allowing say 14 seconds for caging cars each trip, and to cover time lost in starting and stopping each trip, the actual time of hoisting this depth, at maximum speed, would be $34 - 14 = 20$ seconds; and the maximum speed of winding is $400 \div 20 = 20$ feet per second, or 1,200 feet per minute.

It is necessary, now, to calculate the size and weight of hoisting rope required, as follows—Load on rope=coal 3,000 pounds; car, say 1,400 pounds; cage, say 2,000 pounds; total of these=6,400; and adding one-tenth for friction makes the

total load exclusive of the weight of the rope itself, say 7,000 pounds, or 3.5 tons. The diameter of a cast-steel, six-strand, 19-wire hoisting rope for this load, and depth of shaft, using a factor of safety of 8, is

$$d = \sqrt{\frac{8 \times 3.5}{34 - \frac{8 \times 1.58 \times 400}{2,000}}} = .94, \text{ say, 1-inch rope}$$

The weight of this rope is $400 \times 1.58 = 632$, say, 700 pounds. The next step is to find the load on the engine, which, for a double-compartment shaft, is the unbalanced weight of coal and rope, plus the friction of the hoist; thus, coal 3,000 + rope 700 = 3,700 pounds. Allowing 20 per cent., as stated in question, for resistance of engines, ropes, and pulleys, gives for the total load on the engine $3,700 \div .80 = 4,625$ pounds. To hoist this load at a speed of 1,200 feet per minute will require $(4,625 \times 1,200) \div 33,000 = 168$, say 175 indicated horsepower of engine. A duplex, geared, or second-motion engine will be used, each cylinder being calculated for the full horsepower required. For a steam pressure of 70 pounds at the throttle, and say a $\frac{5}{8}$ cut-off, the mean effective pressure in the cylinders is $.9 [(14.7 + 70) .904 - 17] = 53.6$ pounds per square inch. Now, assuming an efficiency of the engine of, say 85 per cent., and a piston speed of, say 630 feet per minute, the diameter of a steam cylinder required to develop 175 horsepower, is

$$d = 205 \sqrt{\frac{175}{.85 \times 53.6 \times 630}} = 16 \text{ in.}$$

Assuming a length of stroke of 20 inches, the engine must make $\frac{630 \times 12}{2 \times 20} = 189$ revolutions per minute. If the ratio of gearing

is 1 : 3 the winding drum will make $189 \div 3 = 63$ revolutions per minute. For a rope speed of 1,200 feet per minute the diameter of coils on the drum will be $\frac{1,200}{3.1416 \times 63} = 6.06$, or practically 6 feet 1 inch. Since the diameter of the rope is 1 inch, the diameter of the drum is 6 feet. The size of the engine is as given above, 16 in. \times 20 in.

Ques. 11.—(a) What constitutes a safety lamp? (b) Describe the Davy lamp and state under what conditions it is unsafe. E., June 27, Q. 2

Ans.—(a) Any lamp in which the flame or other source of light is more or less completely isolated from the atmosphere surrounding the lamp comes within the meaning of the term "safety lamp," as applied to mining. The general acceptance of the term at present, however, includes only those types of lamp in which the flame is inclosed in a chimney of wire gauze or glass and wire gauze combined. But since electric lamps are rapidly coming into use in mines, the meaning of the term safety lamp must be extended to include all incandescent lamps designed for mining use. (b) The Davy lamp consists ordinarily of a brass or aluminum oil vessel surmounted by a cylindrical wire-gauze chimney varying in height from $4\frac{1}{2}$ inches to 6 inches and being generally $1\frac{1}{2}$ inches in diameter. The standard wire gauze in use has a mesh of 28 wires (No. 28, B. W. G.) to the inch, making $28^2 = 784$ openings per square inch. This gauze chimney is closed at the top where it is further protected by a gauze cap that fits snugly over the top of the chimney. There are many types of Davy lamps; some are protected by a glass or a steel bonnet covering a portion of the gauze chimney; others are provided with a metal shield on one side of the chimney; still others (tin-can Davy) are quite enclosed in a metal case with a glass window, resembling a lantern. The unbonneted Davy lamp is unsafe when exposed to a gaseous current having a velocity exceeding 6 feet a second. The lamp is also unsafe when improperly or carelessly handled, or not properly put together, or when the gauze is dirty or defective, or has become heated by too long exposure to gas.

ORE MINING AND METALLURGY

Petroleum in Oklahoma

Location of the Oil District. History. Geological Conditions. Quality and Quantity of Output

By Lucius L. Wittich

Early operations in search of crude petroleum were launched in Oklahoma (then the Indian Territory) as early as 1882, but it was not until 1906 that the first great discoveries in the Glenn Pool district were made.

Prior to the opening of the Glenn Pool district, the region between Bartlesville and Tulsa had been tested to some extent.

It is estimated that of this quantity Oklahoma produced more than 16,000,000 barrels. Last year the production of Oklahoma alone was 54,000,000 barrels. A glance at the map, Fig. 2, shows to what extent the oil regions of Oklahoma may be developed. Fig. 1, showing one view of the Glenn Pool district, gives an idea of the uses to which concrete is put in the construction of reservoirs for crude oil.

After two years of scattered prospecting on the part of residents of the Indian Territory, the Cherokee and Choctaw nations, in 1884, awakened to a realization of the possibilities of buried wealth. In that year the Choctaw Council passed a law creating the Choctaw Oil and Refining Co., "for the purpose of finding petroleum, or rock oil, and increasing the

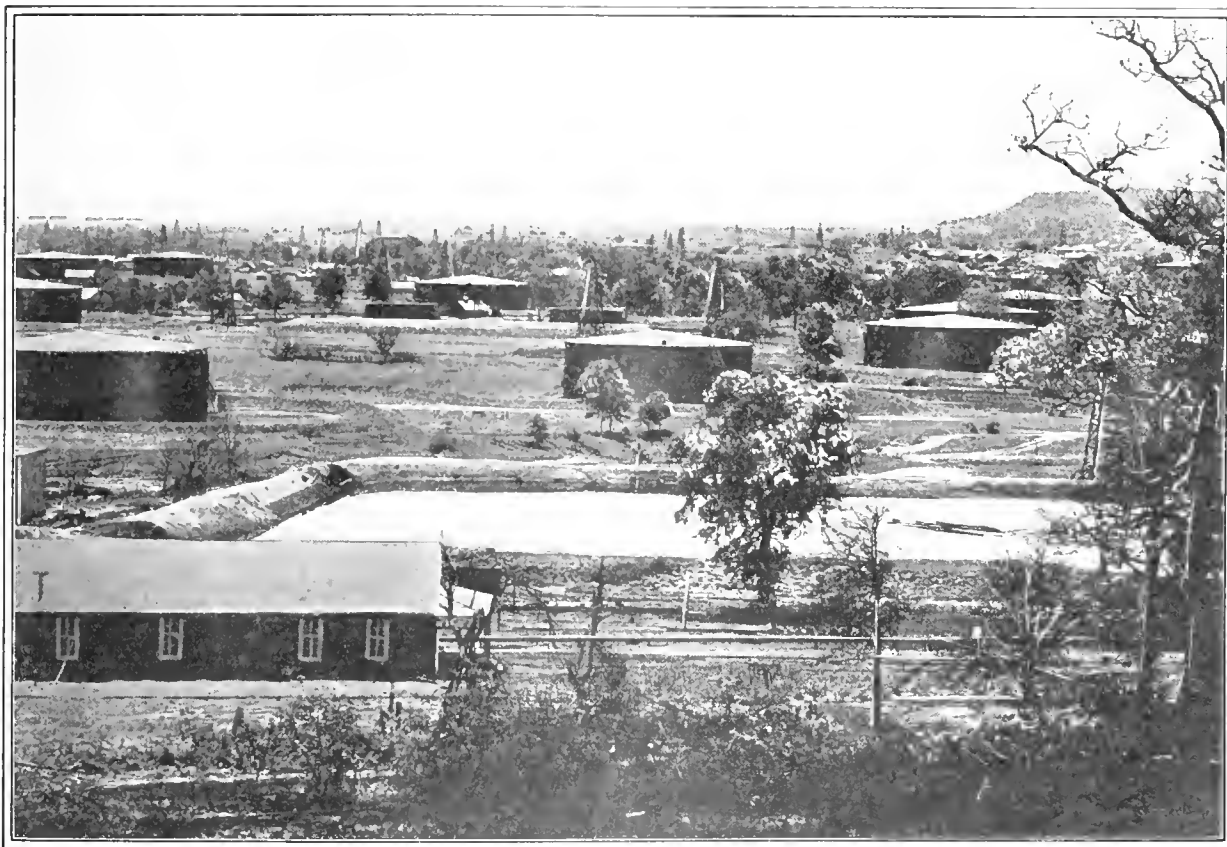

FIG. 1. CONCRETE OIL RESERVOIR, GLEN POOL, OKLAHOMA

Prospectors then pushed southward, and during the early summer of 1906, Glenn well, No. 1, was brought in, featuring the opening of one of the greatest oil pools so far known. Since then the field has expanded and the production of crude petroleum in Oklahoma increased to such an extent that in 1907 and 1908 Oklahoma led the United States in production.

Although crude oil development in Kansas was launched long before development was started on an extensive scale in Oklahoma, the oil fields of the two states have become intimately associated under the common caption, "The Mid-Continent Field" and because of this relationship it has been more or less difficult to keep the production of the two states separate. In 1906 the Mid-Continent field produced 22,000,000 barrels, and it is esti-

rated that of this quantity Oklahoma produced more than 16,000,000 barrels. Last year the production of Oklahoma alone was 54,000,000 barrels. A glance at the map, Fig. 2, shows to what extent the oil regions of Oklahoma may be developed. Fig. 1, showing one view of the Glenn Pool district, gives an idea of the uses to which concrete is put in the construction of reservoirs for crude oil.

After two years of scattered prospecting on the part of residents of the Indian Territory, the Cherokee and Choctaw nations, in 1884, awakened to a realization of the possibilities of buried wealth. In that year the Choctaw Council passed a law creating the Choctaw Oil and Refining Co., "for the purpose of finding petroleum, or rock oil, and increasing the revenue of the Choctaw Nation." The act was approved by the principal chief, Edmund McCurtain. The Cherokee Nation passed a similar law a few weeks later, and D. W. Bushyhead, the principal chief, signed the bill. Companies were organized in each Nation and the prospecting concerns united in associating themselves with Dr. H. W. Faucett, of New York, for the purpose of development. Preliminary prospecting was started about 14 miles west of Atoka; another well was drilled about 20 miles north of Talequah, the capital of the Indian Territory. Adverse legislation came in 1885 and operations were suspended. Eastern investors were frightened from the field and despite the reinstatement of the charter by the next Cherokee Council it was difficult to interest foreign capital in

the 1880's. Well workings were at a standstill in the Cherokee Nation. Some work was being done in the Choctaw Nation, St. Louis, Mo., having been interested in the undertaking. In 1888 important development had been made, holes having been drilled to almost 2,000 feet. Indications of oil were encountered at various depths, the first evidence of oil being found at a depth of 454 to 524 feet. More oil was encountered at a depth of 917 feet. At 1,235 feet a still better showing of oil was encountered. Again at 1,302 feet there was a small showing of oil. Indications of both oil and gas were encountered at 1,347 feet and 1,391 feet.

Extensive oil development was launched in 1894 by the Cudahy Oil Co., of Omaha, this concern having secured a blanket lease on the Creek Nation. McBride and Bloom, of Independence, Kans., were employed to drill the first wells, the initial boring being done on what is now a portion of the Muskogee townsite. Oil was found at 1,120 feet. At a depth of 1,800 feet the hole was lost. In the second hole, 900 feet southwest of the first location, high-grade oil was discovered at a depth of 645 feet. The sand was shot and production was recorded. The hole was sunk deeper for prospecting purposes, work being abandoned at 1,300 feet. In 1904, when titles to the land could be procured, drilling was resumed, and in the vicinity of Muskogee much work is still in progress.

In March, 1896, the Osage Council passed a bill permitting oil and gas exploitation. Edwin B. Foster acquired a lease which gave him an exclusive franchise to operate in the Osage country. A five-barrel producer was the result of the first well sunk, three miles south of Chautauqua Springs. The oil was encountered at a depth of 1,100 feet.

In 1897, McBride and Bloom, encouraged by their efforts near Muskogee, sunk a well at Eufaulfa on their own responsibility. Drilling was continued to 2,575 feet, oil being encountered at three horizons and gas enough at 2,475 feet to fire the boiler.

While these efforts were in progress in the Indian Territory, some drilling was being done without success in Oklahoma Territory. However, a good pool was opened at Cleveland, Okla., in 1904.

As far back as 1886 extensive development was undertaken by Edward Bird, west of Chelsea, and in 1891, 11 wells were producing oil on this tract. Unsatisfactory governmental conditions caused a temporary discontinuance of operations in this field as they had in other portions of the Indian Territory. The leases passed into the hands of the Cherokee Oil and Gas Co. The holdings of this concern were materially decreased by the Curtiss Bill, of 1896. Various companies were shorn of all improved territory by this measure. Unsettled conditions resulted in little work being done until 1904. Since then

development has been almost phenomenal, drill rigs having been stationed throughout the entire north central portion of the new state.

In the Creek Nation, in which the Glenn Pool is located, the first development of note was conducted by Dr. Fred S. Clinton, of Tulsa, and Dr. J. C. W. Bland, of Red Fork, who drilled near Red Fork. Coleord and Calbreth opened Glenn well, No. 1, in 1906.

Pipe-line facilities are now ample to care for the heavy production of crude petroleum in Oklahoma. Recently the Oklahoma Pipe Line Co. completed an 8-inch line to the Gulf. Improvements and extensions have been made in the lines of the Prairie Oil and Gas Co., the Gulf Pipe Line Co. and the Texas Co. Prior to 1910, producers were handicapped because of inadequate pipe-line facilities. Statistics gathered early this year show that the Prairie Oil and Gas Co. had 801 steel storage tanks in Oklahoma, running from 35,000 barrels to 55,000 barrels. The Gulf Pipe Line Co. was reported to have 120 steel tanks and the Texas Co. 64. In addition to these, 101 tanks were reported to be owned by various producers throughout the field, making a total of 1,086 tanks, bull's-eyes for stray lightning bolts that chanced to be playing about the heavens.

Heavy damage has resulted from lightning striking tanks, Fig. 3 showing a steel tank thus struck. An idea of the resulting loss in such cases may be had from the instance in hand. The tank, the capacity of which was 55,000 barrels, and which was the property of the Prairie Oil and Gas Co., was valued at \$13,500. The value of the oil on hand was about \$20,000,

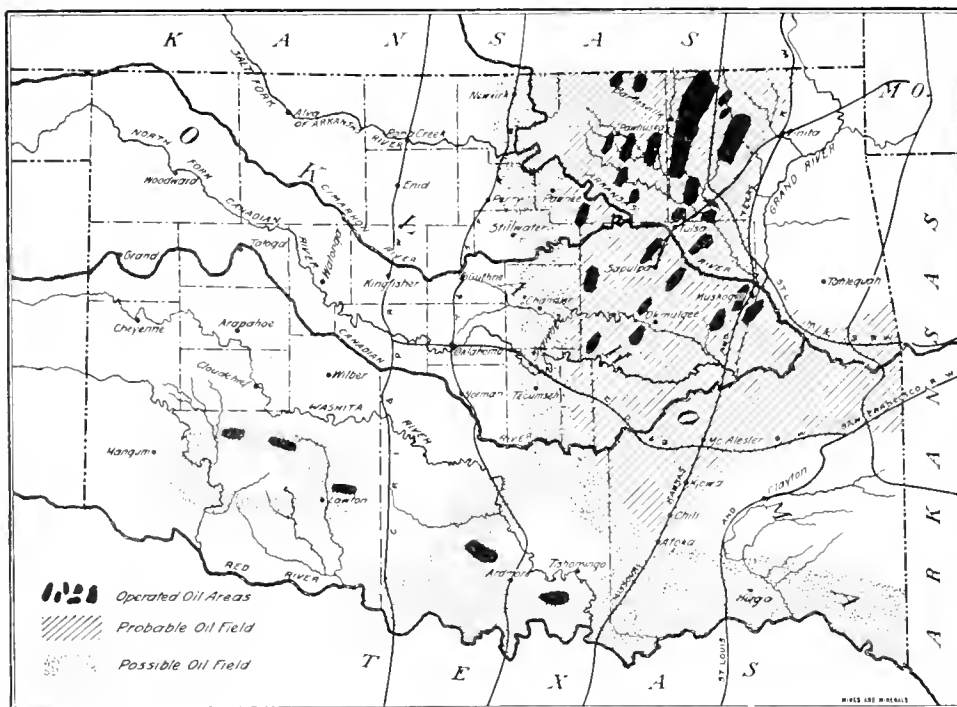

FIG. 2. OKLAHOMA OIL REGIONS

making the total loss \$33,500. The possibility of loss from lightning is a factor with which the majority of the oil producers of California do not have to contend, chain lightning in Southern California being almost unknown.

TABLE I

Field	Number Wells	Daily Production Barrels	Average Per Well Barrels
Glenn Pool	2,101	38,227	18 1/2
Hamilton (Preston)	74	1,991	24 1/2
Bald Hill	136	3,306	23
Henrietta and Tiger Flats	22	995	45
Flat Rock	173	5,495	31
Turley	134	1,620	12
Bird Creek	221	4,050	18
Muskogee	200	5,405	27
Morris	62	955	15
Nowata	6,223	24,772	3 3/4
Rogers County	1,827	4,629	2 1/2
Washington County	2,939	16,183	5 1/2
Osage Reservation	1,027	16,308	15 1/2

It is estimated that the total storage of Mid-Continent oil aggregates 58,000,000 barrels, of which the greater part is

in Oklahoma. Estimates place the aggregate trunk line mileage between 1,200 and 1,500 miles.

Recent estimates by the Oklahoma Geological Survey place the average daily production of oil at 121,837 barrels, the total producing wells at more than 15,000, and the average production per well per day eight barrels. The producing districts are divided as shown in Table 1.

Figures of the United States Geological Survey show the initial average daily production of oil wells in Oklahoma to be as follows: Average per well, 1905, 51.1 barrel; 1906, 71.1 barrels; 1907, 131.7 barrels; 1908, 87.1 barrels; 1909, 75.3 barrels; 1910, 60 barrels.

During the past fiscal year, according to the report of the oil and gas inspector of Oklahoma, the value of petroleum and gas produced and sold aggregated \$18,000,000. Within the year 3,340 wells were drilled, of which number 2,803 were oil wells and 135 were gas wells. Four hundred and two were "dusters."

Refinery tests of Oklahoma crude oil of 36 gravity show the following results:

	<i>Per Cent.</i>
Benzine products.....	20
Illuminating oil.....	32
Light neutral distillate.....	18
Fuel oil.....	28
Lost by evaporation.....	2

The greater part of the oil is purchased by three companies, the Prairie Oil and Gas Co., which is a subsidiary of the Standard Oil Co., the Texas Co., and the Gulf Co.

Geologically, the formation of the Oklahoma oil fields is, for convenience, divided into the Main field and the Arbuckle-Wichita region. The main field takes in the northeast part of the state, the probable oil areas extending well south toward Texas. The Arbuckle-Wichita field is to the west, where geological conditions are more complex than in the main field. The indications are that both fields were lifted above sea level at the same time.

Both oil and gas at Wheeler, Lawton, Gotebo, and Granite, are found along or near the old unconformity, probably between the Carboniferous and the Permian-Carboniferous rocks, and the theory is advanced that the liquid seeped into the Permian Red Beds from older rocks, rather than originating in the Red Beds themselves.

In the Main field, the rocks merely consist of alternating strata of limestone, shale, sandstone, and occasional beds of workable coal. The oils and gases are found in rocks of the Carboniferous period, although some gas is reported to have been found in the more ancient rocks of the Mississippian. Rocks of the Carboniferous system outcrop in Northeastern Oklahoma, Southeastern Kansas, and at a few points in Southwest Missouri, in which region some prospecting for oil has been conducted without success, although some petroleum has been encountered at great depth north of Alba, Mo. The outcrop of the Carboniferous rocks follows the course of Spring River as it winds through portions of the three states mentioned. At many places along this stream, rocks of the Mississippian form

the surface on one side but dip beneath the outcropping Carboniferous on the other. As the Mississippian gradually dips toward the west, averaging about 20 or 30 feet fall to the mile, the thickness of the Carboniferous increases proportionately and in the extreme west portion of the oil fields drill holes have been sunk to almost 3,000 feet without encountering the Mississippi limestone. The greatest oil pools are found along or just above the unconformity between the Mississippian and the Carboniferous rocks. Immediately above the Mississippian comes the Cherokee shales, with an average thickness of 400 to 500 feet and these are capped by the Fort Scott limestone, above which are alternating shales and limestones extending to the surface. The great sandstone beds, some in the form of lenses, shaped like pumpkin seed, and others of uniform thickness extending over a greater area, occur, for the most part, in or

at the base of the Cherokee shales. Near the top of the Cherokee shales another horizon of "oil" is found, and still another is encountered above the Fort Scott limestone. No geological connection seems to exist between the oil fields of the Mid-Continent region and those of other portions of the United States.

Charles N. Gould, director of the Oklahoma Geological Survey, makes the statement that it is a geological impossibility for the Mid-Continent field oils to be connected with the fields of Corsicana and Beaumont, in Texas.

Geological conditions in Oklahoma have proven ideal for the storage of vast quantities of petroleum and gas. First, the source of supply was extensive, extending over a great area as already proven by the producing wells; second, the great beds of sands, acting as reservoirs in which the products have been stored; and third, the almost impervious Fort Scott limestone, forming a cap rock through which the oil and gas escape through natural crevices only at rare intervals. The absence of any one of these conditions would have broken the happy combination which has resulted in Oklahoma being

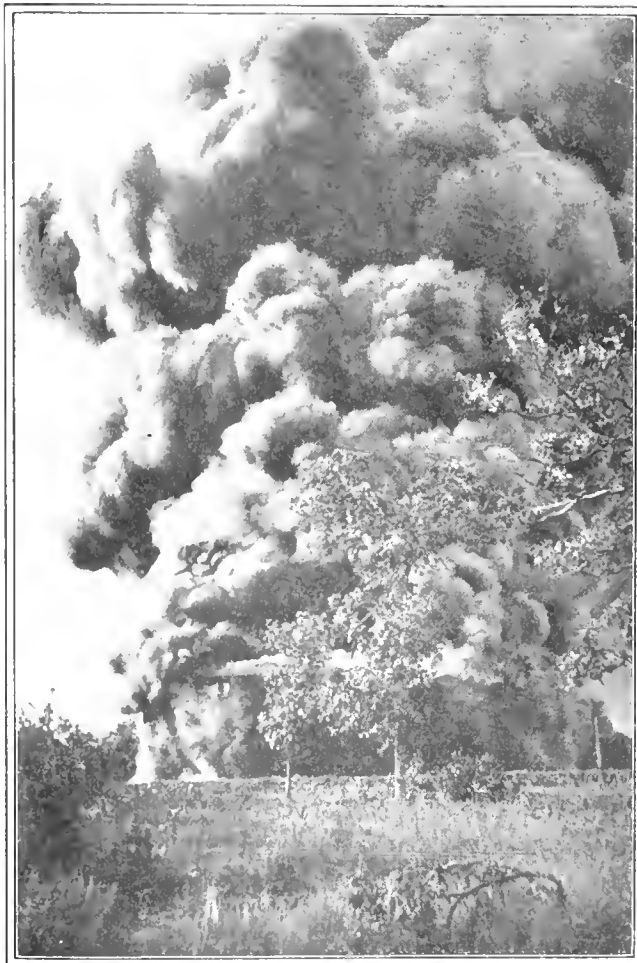

FIG. 3. OIL TANK SET OFF BY LIGHTNING

famous as a producer of petroleum. The gentle undulations of the surface correspond in a great degree to the folds of the earth hundreds of feet beneath, and from these surface indications oil prospectors secure valuable hints on locating wells. Along the crests of the anticlines the greater part of the oil and gas is naturally found. A hole sunk into a syncline almost invariably goes into salt water, for the oil, gas and salt water, obeying an elementary law of physics, will arrange themselves in the order of their specific gravities. A shot of from 10 to 100 quarts of nitroglycerine, Fig. 4, discharged at the bottom of a freshly sunk well, will open the oil sand, leaving a clear space in which the liquid can accumulate and from which it can be pumped if the pressure is not great enough to form a gusher.

Churn drills are used in sinking the wells, the derricks, because of the great depth to which the majority of the holes

are built of heavy, solidly constructed, and not of the fragile type of metal commonly used in many of the metal mining regions where the depth of the drilling is only a few hundred feet. All holes are drilled to the bottom.

Well shooting is a distinct profession in the Oklahoma oil fields. It is the laws prevent the promiscuous handling of nitroglycerine on railroads, and as a result the greater portion of this dangerous explosive is conveyed across country in wagons. Following the lowering of a nitroglycerine cartridge into the well, a "go-devil," weighing 75 or 100 pounds, is dropped into the opening. The force of the impact when the sharp-pointed "go-devil" strikes the charge causes the explosion, and if a heavy pressure is behind the oil the thick, black fluid will shoot

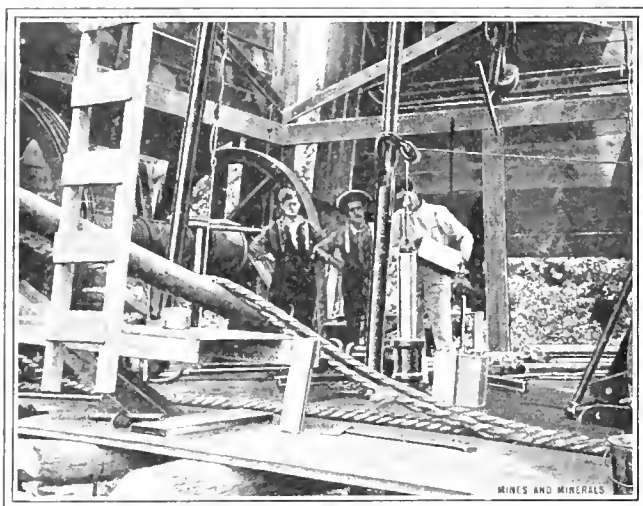

FIG. 4. LOADING A WELL WITH NITROGLYCERINE

high into the air. Often the flow will continue for weeks or even months, after which the oil can be raised by pumping jacks, many of which can be operated from one central pumping station. Two men, one for the day shift, the other for the night, can care for a central pumping station operating as many as 20 wells.

Operators, as a rule, own their own lands, an unwritten law of the field requiring them to put down wells at a reasonable distance from their boundary lines. This rule almost invariably is observed to the letter and crowding of wells is not one of the evils of the field. Where operators lease their lands the customary royalty charged is $12\frac{1}{2}$ per cent.

采 采

Production of Natural Gas

The entire output of natural gas in the West Virginia oil fields is estimated by H. A. Danne, in *Metallurgical and Chemical Engineer*, at 1,300,000,000 cubic feet per day, of which about 300,000,000 cubic feet are wasted. The thermal efficiency may attain as much as 1.134 British thermal units per cubic foot, but after compression of the gas it falls to about 900 British thermal units owing to the deposition of liquefied hydrocarbons. It is employed for power purposes, zinc smelting, and the manufacture of glass, bricks, pottery, electrodes, and lampblack. Judging from the fact that the oil and gas are accompanied by coal and salt water, and that the pressure of the gas is nearly always affected by seismic disturbances, the author considers that these hydrocarbons are generated from natural carbonaceous deposits, by the earth's interior heat brought into proximity to these deposits by seismic disturbances; that they are still being generated under enormous pressure, and that on the release of some of the pressure, and consequent changes in the temperature of the hydrocarbons, some of the constituents are deposited in the dips of the strata and in the pockets known as oil-bearing pools.

American Institute of Mining Engineers

An Account of the California Meeting and Excursions Preliminary to Starting for Japan

As one of the visiting members remarked: "While the avowed object of the meetings of the Institute is the reading and discussion of papers upon technical subjects, yet the chief pleasure of these meetings consists in the trips, in sight seeing under unusually favorable circumstances, in the lavish hospitality accorded at all stopping places, and in the renewal of old friendships and the making of new ones; the papers may be read later and at any time, but the trips may be made but once." As this is generally admitted, a report of the San Francisco meeting of the American Institute of Mining Engineers must necessarily include some account of the trip.

Leaving Chicago at 10 o'clock on the night of Saturday, September 30, a special train of six cars in charge of Mr. Clarence Eaton, as representative of the railroad, started over the Santa Fe with 66 members and guests on the 2,265-mile journey to Los Angeles. Albuquerque was reached at noon, Monday, where a stop of an hour was made to inspect the Fred. Harvey collection of relics of Indians of the Southwest, probably the best of its kind extant. The same afternoon a stop of half an hour was made at Laguna, N. Mex., to visit the Indian village at that point.

The Grand Cañon of the Colorado was reached early Tuesday morning, where two delightful days were spent at the magnificent Hotel El Tovar. While the cañon was more or less familiar to all, either through Moran's painting or college textbooks, no preconceived idea is comparable with that derived from actually seeing what may be called "the eighth wonder of the world."

Los Angeles was reached at 2:30 on Thursday afternoon, October 5th, where the visitors were met at the depot by a committee of the local members of the institute, headed by R. W. Hadden, and consisting of A. A. Burnand, T. B. Comstock, A. Doerr, G. Johnson, Jr., L. Lindsay, F. J. H. Merrill, R. H. Norton, S. F. Parrish, and W. F. Staunton, who escorted them to the Hotel Alexandria, the local headquarters, where an informal reception was held by the ladies committee, Mesdames Theo. B. Comstock, R. W. Hadden, C. Colcock Jones, Seeley W. Mudd, R. H. Norton, and W. H. Wiley. The same evening the Sierra Madre Club members of the Institute entertained the visitors at dinner, at which Mr. William Mulholland gave an interesting illustrated lecture on the Los Angeles aqueduct, of which he is engineer in charge.

Friday, the 6th, the party made a trolley trip to many points of interest round about Los Angeles, visiting Hollywood, the Soldier's Home, Santa Monica, Ocean Park, Venice, and Redondo. At Redondo the power plant of the Pacific Light and Power Corporation was visited, a bath taken in the plunge where the ocean water is maintained at a constant temperature, and the day concluded by a fish dinner at Hepburn & Terry's restaurant.

On Saturday, the 7th, a majority of the party toured the city in automobiles in the morning, visiting friends or resting in the afternoon, while some few passed the entire day in making the trip to and from Avalon on Santa Catalina Island, a trip as memorable in its way as that to the Grand Cañon.

Leaving Los Angeles at midnight Saturday, Santa Barbara was reached early Sunday morning, the 8th, where the day was spent in driving, bathing, and resting up after the strenuous visit at hospitable Los Angeles. Leaving again at midnight, the party reached Del Monte several hours behind schedule on Monday afternoon, the 9th, and only a portion of the program could be carried out. However, all will remember with pleasure the beautiful 17-mile drive.

San Francisco was reached the same evening, Monday, and the party at once went to the Institute headquarters at

the Hotel Saint Francis, where the management of the meeting was in the hands of a committee consisting of W. C. Ralston, S. B. Christy, F. W. Bradley, M. L. Requa, H. Foster Bain, and E. H. Benjamin, who left nothing undone to add to the pleasure and comfort of the guests.

The opening session of the meeting was called to order in the red room of the St. Francis on Tuesday afternoon, the 10th, by R. W. Hunt, after a short address of welcome by Hon. W. C. Ralston, chairman of the local committee. Following the sending of a telegram to President Kirchoff expressing regret at his unavoidable absence, E. B. Durham, of Berkeley, Cal., read a most interesting paper on the electrolytic methods of refining used at the San Francisco mint. This was followed by a paper by Bernard MacDonald on the "Parral Tank System of Agitation," describing a new system recently introduced by him in Mexico. B. W. Vallat's illustrated talk on the "Geology and Operation of the Newport, Mich., Mine," of which he is manager, was one of the features of the meeting; few, if any of those present having any idea of the advanced practice prevailing in the iron mines of that state. This paper was discussed at length by Gardner Williams, and some interesting comparisons made with conditions on the Rand. The session closed with another illustrated lecture by Prof. S. B. Christy, of Berkeley, Cal., on "Progress in Electro-Amalgamation," describing at length the results of his many experiments extending over the past 10 years.

At the session Wednesday morning a letter from Lewis E. Aubury, state mineralogist, was read, extending to the members a cordial invitation to visit the state mining exhibit in the Ferry Building. John A. Brittain, representing the Panama-Pacific International Exposition, in a witty speech requested the delegates to revisit San Francisco in 1915. A telegram from New York was read announcing the establishment at Columbia University of a research scholarship in economic geology in memory of Samuel Franklin Emmons. The intention is to raise a fund of \$25,000 for this purpose, subscriptions to be sent to Benjamin B. Lawrence, treasurer, 60 Wall Street, New York, N. Y. The first paper of the day was a most interesting one on "California Oil," by Mark L. Requa, which was discussed at some length by Doctor Raymond. This was followed by a paper on "Present-Day Problems in Dredging," by Charles Jannin and Francis J. Dennis, both of San Francisco, Cal., and read by Mr. Dennis, which aroused an interesting discussion. Followed, the paper of Charles G. Yale, of San Francisco, Cal., on "Gold Production of California," with the statistics of which he has had many years experience. A feature of this session was the paper by Thos. T. Read, associate editor of *The Mining and Scientific Press*, San Francisco, Cal., on the "Mineral Resources of China," a subject with which the author was thoroughly familiar from many years residence in the country. The illustrations showing the peculiar metallurgical and mining methods employed in that country, and the statements of labor costs and efficiency were much appreciated.

Wednesday afternoon the delegates left on a special train for the Leland Stanford, Jr., University, at Palo Alto, where they were welcomed at the station by a delegation from the senior class, escorted to the college grounds in special trolley cars, and after visiting the buildings, including the magnificent art gallery, were served with a lunch at the Delta Upsilon fraternity house.

At the Thursday morning technical session Robert W. Hunt presided, subsequently being succeeded in the chair by secretary-emeritus Rossiter W. Raymond. Reija Kanda, consulting engineer, who arrived that morning from Tokyo, Japan, to accompany the visitors to the Orient, was introduced and spoke at length upon what the visitors were about to see, comparing the differences between his own country and the United States. Prof. Jos. Daniels, of South Bethlehem, Pa., read a most interesting paper on "The Fritz and Coxé Laboratories"

at Lehigh University. Followed, the paper of Prof. Geo. T. Young, of Reno, Nev., on slime filtration, describing recent advances in this branch of metallurgy. The address of H. Foster Bain, editor of *The Mining and Scientific Press*, San Francisco, Cal., on some features concerned with the coal land situation in Alaska brought out a most animated discussion. Mr. Bain took the progressive stand that the national resources are the property of the people as a whole and should be administered on this basis for the good of all the people, advocating the opening of a mine by the Government in Alaska pending the enactment of proper legislation looking to the equitable disposition of the public domain. In this he was ably seconded by Dr. E. W. Parker, of Washington, D. C., who called attention to the fact that probably less than 100,000 tons of coal a year were at present consumed or required in that territory. Doctor Raymond took the opposite and conservative stand, claiming that the Government should place the remaining resources of the country freely, without price, let, or hindrance in the hands of the first comers, who should be free to combine or not as best suited their own interests. Doctor Raymond complained bitterly of the multiplicity of our land and mining laws and the various and peculiar ways they have been interpreted by the courts, stating no man knew whether he was a criminal or not in the present state of legislation.

Thursday afternoon the Institute visited the University of California, at Berkeley, where, after inspecting the beautiful buildings and grounds, they listened in the Greek Theatre, to a most enjoyable lecture by Doctor Raymond on "Reminiscences of the Beginning of the Institute." Unfortunately, Dr. G. T. Becker was unable to be present and his "Biographical Notes On S. F. Emmons" were not read.

Friday morning, the 13th, many of the visiting members left on a special train for a trip of inspection to the dredging operations of Natomas Consolidated of California, at Natoma. After a most delightful lunch on the lawn of the residence of General Manager Newton Cleaveland, whose guests the party were, the two largest dredges (bucket capacity 15 cubic feet) in California were inspected, and after a short trip by rail the rock-crushing plant of the same company at Fair Oaks, where some 1,500 tons daily of boulders from the dredging operations are converted into material for concrete, road making, and railroad track ballast. The most interesting feature of this trip was perhaps not the two enormous dredges, but rather the evidences of the extreme care with which the hitherto unused by-products were rendered useful. Not only is the waste rock, as stated, converted into ballast, concrete, and macadam-making material of value, but the very ground itself, consisting of large pebbles and apparently destitute of soil, is planted in eucalyptus, grapes, and fruit trees.

Saturday, the 14th, except for an automobile trip to Golden Gate Park, where President Taft turned the first shovel full of earth for the Panama Pacific International Exposition, was largely a day of rest or passed in visiting local plants of interest.

Early Sunday morning, as guests of the Bohemian Club of San Francisco, the visitors left for Bohemia, the beautiful grove of big trees, one of the few remaining, where the club holds its annual revels. Lunch was served in the grove and after that the delegates listened to the "Music of Bohemia," largely written by members of the club and rendered by Sabin's orchestra.

Monday was a day of rest, and on Tuesday, the 17th, about half the party left for home at 10:40 in the morning via the Southern Pacific, Union Pacific, and Chicago, Milwaukee & St. Paul Railroads. The remainder of the visitors, together with a sufficient number who came directly to San Francisco to make a party of 85, left at 1:30 o'clock the same afternoon on the "Manchuria" for Japan, where they will be guests of the Mine Owner's Association of that country. Eighteen days, both going and coming will be passed on the Pacific, with stops of one day in Honolulu and of 17 days in the Island Kingdom.

Common Features of Silver Districts

With Special Reference to the Geological Features of the Silver Producing Areas of Colorado

By W. G. Malletson, E. M.*

In listing the world's greatest silver districts, one is necessarily limited by certain factors such as the richness of deposit and extent of production. Neither one of these facts can be disregarded absolutely in favor of the other, although there are instances where the quantity of production has so far over-

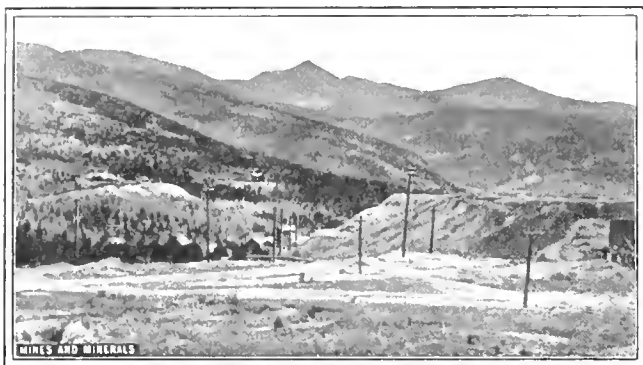

MOSQUITO RANGE FROM IRON HILL, LEADVILLE, COLO.

balanced other considerations as to cause camps producing a relatively low-grade ore to be placed in the front ranks of the greatest silver districts.

In attempting this classification, however one cannot confine himself to regions producing silver almost exclusively, for the greatest source of silver supply can be attributed to mines in which lead, copper, zinc, or gold have also been found and mined in great abundance. With these limitations, therefore, a fair and conservative classification would include the well-known districts of Guanajuato and Pachuca, Mexico; Broken Hill, Australia; the Cobalt district of Canada; and the Comstock Lode, Leadville, Aspen, Tonopah, and the Park City regions of the United States.

Guanajuato has the reputation of having been the most productive silver mining district in the world, its total output exceeding a thousand million ounces. Cobalt takes rank as one of the richest silver producing regions ever known, its minerals assaying up to 7,000 ounces of silver per ton. The Broken Hill field is classed among the greatest mineral exploitations of man and has been characterized as one of the largest and most consistent silver-lead lodes in the world. The Comstock Lode has produced 300,000,000 ounces of silver, some ore running as high as 3,000 ounces to the ton. Pachuca has yielded 112,000,000 ounces of silver since it was first worked, while the Coeur d'Alene field is responsible annually for one-third the total output of the United States. The high grade and wonderful extent of the Aspen ores in conjunction with the neighboring camp of Leadville has served to place Colorado among the most important precious metal producing regions of the country.

The chief silver deposits of the world may be divided into:

1. Those in which the formations are essentially sedimentary in character.
2. Those in which intense volcanic activity has been the most widespread factor.

It is a significant fact, however, that not a single instance can be recorded where volcanic activity or igneous intrusion, especially, has not had a most important influence upon mineral deposition. Moreover, a striking similarity in the character of these eruptives seems to exist and persist with such frequent

Denver, Colo.

regularity as to lead to the conclusion that perhaps the great silver deposits of this class, although widely scattered over the earth's crust, were formed at approximately the same time and under the same conditions. Thus the Comstock Lode, in Nevada, is found to lie in Tertiary eruptive rocks, chiefly andesites, which cover an extensive area and which have undergone widespread decomposition and propylitic alteration. Proceeding a few miles to the southeast in the same state, similar occurrences are encountered at Tonopah where Tertiary lavas, chiefly andesites and rhyolitic breccias and tuffs, cover the greater part of the ore bearing district. All of the Pachuca range of Mexico is formed from volcanic Tertiary rocks which may be classed as andesites, rhyolites, and basalts. The ore deposits are found in andesite of Miocene age, as at the Tonopah and Comstock lodes. Guanajuato has also seen great volcanic activity. The entire district is covered with a long series of andesitic and rhyolitic breccias and tuffs, the latter carrying some of the most important silver veins in the world.

At Leadville, which is situated on a terrace at the bottom of one of the western spurs of the Mosquito Range, near the head of the Arkansas valley, the geological formations may be described as a succession of metamorphic and sedimentary rocks, such as quartzites and limestones resting upon the older Archean granite. Large and numerous flows of porphyry in the form of dikes, horizontal sheets and overflows have intruded between and across the strata. These flows have had an immense influence upon ore deposition and represent intermittent eruptions covering an indefinite time. After them came the mineral bearing solutions and gases, which penetrated the neighboring rocks along the cracks and lines produced by the porphyry intrusions and, dissolving out portions of the more soluble formations, subsequently deposited their metallic contents instead. This period of ore deposition was followed by one of faulting and general uplifting of which the Mosquito Range is the result. Finally, settling and erosion took place, leaving the district, topographically, as it is today.

The famous silver district of Aspen is found in the same group of mountains as Leadville, located, however, on the west flank of the Sawatch Range. As at Leadville, the fundamental rock is a granite with occasional gneissic structure. Above the granite is found the sedimentary beds of the Cambrian, Silurian,



CARBONATE HILL, LEADVILLE, COLO.

Devonian, Carboniferous, Jura Trias, and Cretaceous in the order named

Two distinct types of igneous rocks, a diorite porphyry and a quartz porphyry, have been intruded into these sedimentaries in Cretaceous time, mainly as sheets parallel to the bedding planes, although occasional cross-cutting dikes are observed. Subsequently the formations were much folded and faulted, the center of greatest uplift and disturbance being the chief center of ore deposition. The important faults occurred previous to ore deposition and the mineral bearing solutions following the fractures thus formed and deposited their contents. In some places, the neighboring rock has been con-

siderably permeated by these solutions which have dissolved out the more soluble parts and have replaced such portions with valuable mineral.

Sedimentary formations also make up the greater part of the Cœur d'Alene district. The prevailing rocks are arenaceous and argillaceous and include sandstones, slates, and quartzites of Algonkian age. These sedimentaries are cut by a number of masses of syenite, most of which have the form of small intrusive stocks. The rocks in the district have been complexly folded and faulted and strong compression with the result that slaty cleavage is a prominent structural feature. The main ore bodies of the district are found in a fine-grained, sericitic quartzite.

The Wasatch Range, comprising the district of Park City, Utah, consists of extensive sediments of Paleozoic and early Mesozoic rock systems deposited around an Archean core. After this deposition, there was a general uplift with complex folding and faulting. During the Mesozoic era, the Paleozoic formations were cut by numerous igneous intrusions of an even grained diorite and a coarse porphyry. In Tertiary times, there were great volcanic eruptions, followed by the extrusion of andesitic and basaltic rocks. The faulting of these igneous intrusions or dikes by the vein fissures is conclusive proof that ore deposition occurred at a later period. These dikes are important as by cutting through and fracturing the strata they opened the rocks for the mineral-bearing solutions. Here quartzite and limestone of Carboniferous age are also the main ore-bearing formations.

In the Broken Hill district, Australia, also the rocks consist of highly altered slates, conglomerates, sandstones, limestones, and micaceous schists, classified as of Silurian age. Broken Hill itself has been described by Pittman as a low range about 2 miles in length, composed of crystalline gneisses, passing into banded quartzites, micaceous hornblende schists and garnetiferous sandstones. These rocks have been intruded by dikes of very coarse granite and amphibolite, and have been crumpled, contorted and so highly metamorphosed as to leave doubt as to whether they are altered sedimentary or igneous rocks. The position of the lode, it is claimed, was determined by a series of principal faults.

Comparison of the Districts.—A geological section of several of the silver districts will bring out more clearly perhaps the most important similar features, as noted in a description of the areal geology. Thus, from the following order of rock succession, it is seen that the formations of Leadville, Aspen, Cobalt, Guanajuato, Comstock, and Park City regions rest upon a basement complex of granite. At Leadville, Aspen, and Park City, the order of deposition in point of geologic age and character of the formation is almost identical throughout, a series of white Cambrian quartzite, Silurian limestone, Devonian parting quartzite, and Carboniferous limestone following the basement complex of granite in each particular instance. Furthermore, in all three camps, the rich ore is invariably associated with the Carboniferous blue limestone.

GEOLOGICAL SECTION, COMSTOCK LODE, NEV.

General system of rocks, Tertiary volcanics.

1. Granite.
2. Metamorphics.
3. Granular diorites.
4. Porphyritic diorites.
5. Metamorphic diorites.
6. Quartz porphyry.
7. Earlier diabase.
8. Later diabase.
9. Earlier hornblende-andesite.
10. Augite andesite.
11. Later hornblende-andesite.
12. Basalt (youngest).

GEOLOGICAL SECTION, TONOPAH, NEV.

General system of rocks, Tertiary volcanics.

1. Earlier andesite.
2. Earlier rhyolite and breccias.
3. Later andesite.
4. Erosion interval.
5. Volcanic breccias and flows.
6. Great water-laid tuff formation containing infusorial silica.
7. Later rhyolite.
8. Latest lava flow.

GEOLOGICAL SECTION, LEADVILLE, COLO.

1. Granite and gneiss (basement complex).
2. White quartzite (Cambrian) 200 feet thick.
3. Drab dolomitic limestone (Silurian) 160 feet.
4. Parting quartzite (Devonian) 40 feet.
5. Gray monzonite porphyry (Pre-Cretaceous).
6. Blue limestone (Carboniferous) 200 feet thick.
7. White rhyolite porphyry (Carboniferous).
8. Calcareous and carboniferous shales.

GEOLOGICAL SECTION, ASPEN, COLO.

1. Archean granite.
2. White Cambrian quartzite, 200 feet thick.
3. Light gray dolomitic limestone (Cambrian), 100 feet thick.
4. White quartzite, 20 feet to 50 feet thick.
5. Drab dolomite (Silurian) 200 feet thick.
6. Brown quartzite (Silurian) 20 feet thick.
7. Drab dolomite (Silurian) 100 feet thick.
8. Blue limestone (Carboniferous) 120 feet thick.
9. Black calcareous and carboniferous shales.
10. Diorite.

GEOLOGICAL SECTION, CŒUR D'ALENE, IDAHO

General kind of rocks, arenaceous and argillaceous sediments cut by igneous intrusions.

1. Prichard slate. Blue, black, and gray slates.
2. Burke formation. Fine grained sandstones and shales with interbedded quartzite.
3. Revett quartzite. White quartzite.
4. St. Regis formation. Fine grained sandstones.
5. Wallace formation. Sandy shales with thin beds of calcareous sandstones and impure limestones.
6. Sandstones.

GEOLOGICAL SECTION, COBALT, CANADA

1. Basement complex, diabases and granite porphyries, Keewatin.
2. Great unconformity.
3. Coarse conglomerate, impure quartzite, greywacke slate, conglomerate. Lower Huronian.
4. Unconformity.
5. Lorrain arkose, quartzite, and conglomerate. Middle Huronian.
6. Quartz-diorite. Post Middle Huronian.
7. Great unconformity.
8. Niagara limestone.
9. Boulders, clays, sands, and gravels. Glacial and Recent.

GEOLOGICAL SECTION, GUANAJUATO, MEX.

General kinds of rock, andesitic and rhyolitic breccias.

1. Basement complex.
2. Cretaceous shales.
3. Intrusive granite.
4. La Luz schists.
5. Conglomerate.
6. Bufo sandstone.
7. Rhyolitic breccias.
8. Andesitic breccias.
9. Later rhyolites.

GEOLOGICAL SECTION, PARK CITY, UTAH

1. Archean granites.
2. White-Cambrian quartzite.
3. Black limestone, calcareous shale, and slate. Silurian.
4. Devonian quartzites.
5. Siliceous and blue limestones, quartzites. Carboniferous age.
6. Gray shales, red shales, calcareous sandstones, light gray, and blue limestones. Mesozoic age.

GEOLOGICAL SECTION, ASPEN (SPURR)

1. Granite, often changing into gneisses and schists.
2. Thin bed Cambrian conglomerate.
3. Cambrian, 300 to 400 feet thick. Dolomitic quartzite, Glauconitic grit, Sandy dolomite.
4. Silurian (Dolomite), 250 to 400 feet thick.
5. Devonian (Parting quartzite), 60 feet thick.
6. Carboniferous. Leadville limestone, dolomite 350 feet thick. Blue lime. Intrusive white porphyry, like Leadville white porphyry, 250 ft to 400 feet thick. Weber limestones and shales, 1,000 feet thick. Maroon formation, 4,000 feet thick.
7. Triassic. Red sandstones, 2,600 feet thick.
8. Jura Trias. Yellow sandstone and shale, 400 feet thick.
9. Cretaceous. Dakota formation, white sandstone, 250 feet thick. Benton shales, 350 feet thick. Niobrara limestone (gray or blue limestone), 100 feet thick. Montana formation (gray or black shale), 4,000 feet thick. Laramie formation, sandstone, 600 feet thick.

Similar beds at Leadville and Aspen are also approximately of the same thickness. To illustrate, there occurs a bed of parting quartzite separating the dolomite of the Silurian from that of the Carboniferous and running 40 to 70 feet in thickness. Practically the same quartzite is found at Aspen, occurring in the same horizon, of the same thickness and bearing evidence of deposition under closely similar circumstances. The ore-bearing formation at Aspen is known as the "Leadville limestone," due to its close similarity to the ore-bearing strata of the latter camp. In fact, practically the only important differences between the geological sections of these two districts are:

1. The "blue limestone" at Leadville, although identical in geological position with the "blue limestone" of Aspen, is dolomitic or magnesian, while the Aspen formation is nearly pure carbonate of lime and non-magnesian.

2. The position of the "porphyry" is slightly different. The quartz porphyry at Leadville immediately overlies the "blue limestone"; at Aspen there is an interval of 50 to 100 feet of black "Weber" shale between the limestone and porphyry.

3. The porphyry at Leadville lies at the contact between the white quartz porphyry and the blue limestone; at Aspen it is between the blue limestone and pale dolomite.

The ore bodies at Park City also occur in frequent and intimate association with the porphyry. Fissures occupied by ore bodies, cut indiscriminately across porphyry and all other formations.

In the Cœur d'Alene district, 99 per cent. of the ore is found in the Burke formation of fine-grained sandstone and shale and in the Revett formation of white quartzite. The ore bodies of Cobalt, in comparison, are found in the lower Huronian, which comprises coarse conglomerates, quartzites, and slates.

Conclusions.—Thus a marked similarity, amounting in several instances to absolute identity, is revealed in the geologic structure of the silver deposits of sedimentary formation. The same is true also of the ores found in regions of widespread volcanic activity. Among the most important features common to some of the districts in question are:

1. Almost universal similarity in the areal geology of the eruptive formations of the Comstock Lode, Tonopah, Pachuca, and Guanajuato districts, which are composed of Tertiary volcanics, andesites predominating.

2. Identity in age, type of the formation, and order of succession of the various strata of the Leadville, Aspen, and Park City districts.

3. The close and important association of porphyry with the ore bodies of Leadville, Aspen, and Park City.

4. The marked tendency of the ores of Leadville, Aspen, and Park City, for the Carboniferous limestone formation.

5. Similarity in the formations in which the ore bodies of the Cœur d'Alene and Cobalt districts are found.

6. Extensive occurrence of the ore deposits of the Comstock Lode, Pachuca, and Tonopah, in the same kind of igneous rocks.

7. Strong similarity in the character of the porphyry intrusives at Leadville and Aspen.

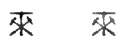

Gold Mining Progress in South Dakota

By Jesse Simmons

President Taft visited Deadwood and Lead, S. Dak., on October 21, and was the recipient of a unique gift from the mining companies operating in the Black Hills district. They clubbed together and furnished one Troy pound of pure gold, which was run into an ingot, suitably engraved, with the names of the companies donating the gold, the date, etc., and presented at a luncheon which was tendered the President at the Franklin Hotel, Deadwood. During his visit to Lead the President and party went down the Ellison shaft of the Homestake mine and later examined the large surface plants at the mine.

Assayer in charge, L. P. Jenkins, of the United States Assay Office, at Deadwood, states that the bullion purchased by this institution for the quarter ending September 30 had a value of \$1,855,000. This production was all from the mines of the Black Hills district. At this rate the mills are turning out more than \$7,000,000 per year, which amount added to shipments made to smelters would probably bring the grand total for the year to a figure far in excess of any previous year. There have been times in the Black Hills when more development was under way than at the present, but on the whole work on new properties is going forward at a very satisfactory pace. Several new mills are being constructed in the region and two of the largest now operating are being enlarged so that it is expected that the output for next year will be even larger than usual.

In the Black Hills district the ores show very little gold by the pan test, so that it is necessary to assay very thoroughly and systematically in order to keep track of the values. Know-

ing this, the Deadwood Business Club recently inaugurated a plan whereby it is able to do free assaying for prospectors. The club made arrangements with six mining companies having assay offices, to make assays for prospectors free of charge. The prospector leaves his samples with the secretary of the Club, who turns them over to the assayers, and when they make their report to him he issues a certificate of assay in the name of the Club. There are only three restrictions connected with the offer, viz.: Samples are accepted from prospector's only, samples must not exceed 5 pounds in weight, each, and not more than ten samples will be assayed per month for any individual. The plan seems to be working satisfactorily and has done a great deal to stimulate prospecting in the region.

The Homestake Mining Co. is rapidly completing its hydro-electric plant on Spearfish Creek, where 6,000 horsepower will be generated for transmission to the mines and mills. The electricity will be used to operate stamps, rock breakers, machine shop, pumps, cyanide plants, and slime plants. This power development is not sufficient to operate the entire plant of the Homestake company, so that it is proposed to continue hoisting by steam power, as in the past. The company operates 1,000 stamps, and as a 25-horsepower motor is being installed to operate each ten stamps it will require 2,500 horsepower for this purpose alone. Twenty 35-horsepower flywheel motors will be used for driving the No. 6 Gates rock crushers, which reduce the rock to 4 inches in diameter preliminary to the stamp milling. The poles for the transmission line from Spearfish Creek, Idaho, are of cedar, in 40-, 45-, and 50-foot lengths. This line will be 12 miles in length, over a rough portion of the Black Hills. A reinforced concrete building is being erected at Lead City as the main substation and from this point the power will be distributed to the various places where it will be used. In connection with this project the company has installed an equipment for wireless telegraphy, stations being located at the main office at Lead and the power plant. The principal necessity for putting in this wireless system was to overcome the delay which might be occasioned by electric storms destroying telephone communication. So far as known this is the first wireless installation that has been made by an inland mining company.

The first gasoline locomotive to be used in the Black Hills for ore hauling has been installed by the Trojan Mining Co. at its property near Deadwood. This locomotive was manufactured by the Milwaukee Locomotive Mfg. Co. It weighs 7 tons, has four cylinders similar to an automobile, developing 35 horsepower, giving a drawbar pull of 2,340 pounds. From the mine to the mill is a distance of a little over 4,000 feet, the steepest grade on the route being 3 per cent. The locomotive easily handles 15 cars of 1-ton capacity each, over this track. The track is 18-inch gauge and is laid with 24-pound steel rails.

The first dredge to be installed in the Black Hills has been completed and put in commission at Mystic, Pennington County, by the Castle Creek Hydraulic Gold Mining Co. The boat is up to date in all particulars, being electric driven from a power plant located convenient to the tracks of the Chicago, Burlington & Quincy Railway. Buckets are eighty in number, of 5 cubic feet capacity each.

A revolving screen 26 feet in length and 6 feet in diameter is used. The capacity is about 2,500 cubic yards per day. Among the special features of the construction of this boat might be mentioned the entire absence of cast iron, high-grade steel being used throughout. Manganese steel is used at points where heavy wear comes, such as the bucket lips, etc., and Tisco steel in nearly all of the other parts of the equipment. Very satisfactory results are being obtained, and many little difficulties incident to the initial operation have been overcome, so that still greater success is confidently anticipated for the future.

The Edison Crusher Rolls

Steam Power vs. Dynamite for Breaking Rock. Illustrated by
Rolls Crushing 20-Ton Pieces

By W. H. Mason

Until a few years ago, rock for feeding crushers could be at most only two-man stone, requiring block holing, mud capping, blasting and sledging in the quarries to obtain the necessary sizes. The demand for enormously increased output in limestone quarries, open-cut iron, and porphyry copper mines in the past few years, has necessitated the design and development of larger, more powerful and efficient crushing machinery. This increased output has been attended with a corresponding increase in the size of the individual pieces; therefore, making it imperative that the crushing apparatus used should be capable of handling the larger pieces as quarried and of reducing them to sizes that would conform with the demands of the cement manufacturer, the blast furnace manager, and the millman.

In approaching this problem of crushing, Mr. Edison reasoned that the total heat energy of 1 pound of pea coal is approximately 12,500 heat units, but only about 15 per cent. of this, or 1,875 British thermal units, is available in mechanical energy through the medium of boilers and steam engines, while the available British thermal units in 1 pound of nitroglycerine is approximately 3,650. Therefore, in 50-per-cent dynamite there is available 1,825 British thermal units, or practically the same mechanical power that can be derived from 1 pound of pea coal. But 1 ton of pea coal is worth approximately \$2.50, while 1 ton of dynamite is worth about \$250, making the commercial advantage of the coal over the dynamite approximately 100 to 1.

The largest jaw crusher that the writer is familiar with is one installed at the Cornwall ore bank, and has an opening 60 in. \times 42 in., while the largest gyratories have approximately the same size opening. The Edison Giant crushing rolls, shown in Figs. 1 and 2, are the first rolls constructed to crush large pieces of rock, and their introduction will aid materially in the treatment of some kinds of ore.

In crushing large pieces of stone by the Edison Giant rolls, there are two distinct actions involved. First, when the large stone is delivered to the rolls, it is shattered by a sledging blow delivered by two rows of extra-high knobs on one of the rolls. After the stone is shattered by the sledging blow, it is caught by the angle of the rolls and forced through, reducing the stone to about 6-inch size. Thus, in one crusher, stone is reduced from 20-ton pieces to 6-inch size.

Three sizes of rolls have been constructed so far; 5 feet in diameter by 5-foot face; 6 feet in diameter by 6-foot face; 6 feet in diameter and 7-foot face. The smallest size rolls will handle material weighing 10 tons, while the large size will crush up to 20-ton pieces. Before Mr. Edison constructed the "Giant" rolls, the largest Cornish rolls were 42 in. \times 16 in. For various reasons these rolls were not popular for fine grinding and were too light for coarse crushing. In fact it is probable that no one except Mr. Edison ever thought of rolls as more than comparatively fine crushers for rock material. An idea of the enormous increase in power of these new rolls over the old-style Cornish rolls may be arrived at by a comparison of the speed and kinetic energy of the two types. The Cornish roll, 30 in. \times 16 in. running at 100 revolutions per minute, had a kinetic energy of 8,100 foot-pounds, while the 6' \times 7' Edison Giant rolls, running at 175 revolutions per minute, have a kinetic energy of 4,217,000 foot-pounds, or in ratio of 520 to 1, while the weights of the rotating parts are as 33 to 1, respectively. It is by use of this kinetic energy that the Edison rolls are able to receive and crush the large pieces of stone at such a rapid rate.

In the arrangement of the crushing plant of the Edison Portland Cement Co., at Stewartville, N. J., one set of 5' \times 5' rolls is placed above two sets of 36" \times 28" rolls and one set of 36" \times 20" rolls. All of these are engine driven. The coarse roll crushes and delivers to the others in sequence and the total product is delivered to a traveling belt at the bottom of the crusher house. This plant handles stone as quarried up to 10-ton pieces at the rate of 3,000 tons in 10 hours. The operating equipment in the quarry consists of one 90-ton Bucyrus steam shovel and one 90-ton Vulcan steam shovel. The quarry is approximately 70 feet deep and about 1,000 feet face. Holes 6 inches in diameter are drilled with churn drilling machines. These holes are 20 to 40 feet centers and are placed 20 to 35 feet back from the face of the quarry. The usual blast is from 6 to 14 holes loaded with 400 to 800 pounds of dynamite each, and breaks down from 40,000 to 70,000 tons of rock. When the hole is drilled it is usually chambered by putting in from 30 to 50 pounds of dynamite and exploding it.

An application of these powerful rolls to crushed stone for ballast, concrete stone, etc., is shown in perspective in Fig. 3. This is the Tomkins Cove Stone Co.'s plant at Tomkins Cove, N. Y. It consists of one set each of 6' \times 7' rolls, 4' \times 4' rolls, and 4' \times 3' rolls, engine driven and having a capacity of 7,000 tons for 10 hours.

To effectively size the large quantity of crushed material coming from the Edison rolls, it has been necessary to design special screens. The bank of screens designed for the Tomkins Cove plant is shown in Fig. 4. The absence of moving parts,

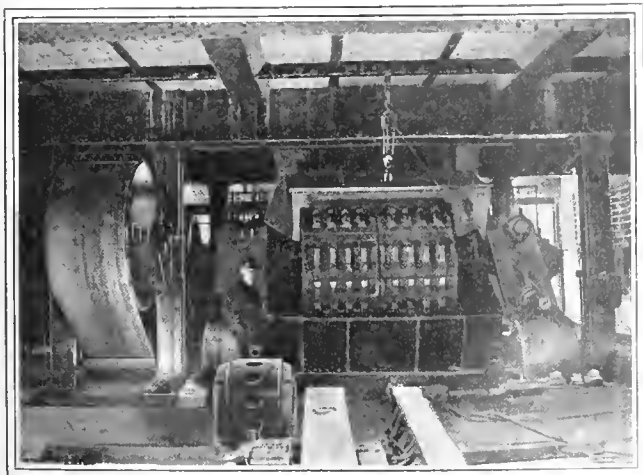

FIG. 1. EDISON 6' \times 7' ROLLS

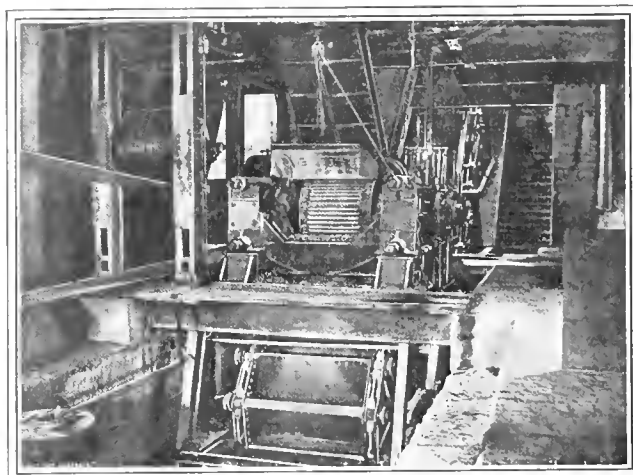

FIG. 2. EDISON 4' \times 3' ROLLS AND CONVEYER

comparatively small floor space. The simplicity of the system appeal to those familiar with the rotary screens as a decided improvement. The stone from Tomkins Cove, after being loaded with steam shovels in the quarry, is dumped into a pair of 6'x7' rolls, which reduce it approximately to 6-inch sizes. Under these rolls there is a hopper having a capacity of about 30 tons. The stone is fed from this hopper by feed rolls to a set of 4'x4' rolls which run at the rate of 250 revolutions per minute. This reduces the stone to about 3½-inch sizes, when it goes directly to a set of 4'x3' rolls and is reduced to about 1½-inch size. A large pan conveyer receives the stone and lifts it to the Edison stationary screen which is shown in Fig. 4. Anything that goes over the screen, that is over 1½ inch, is returned to the lower rolls of the crushing plant for recrushing.

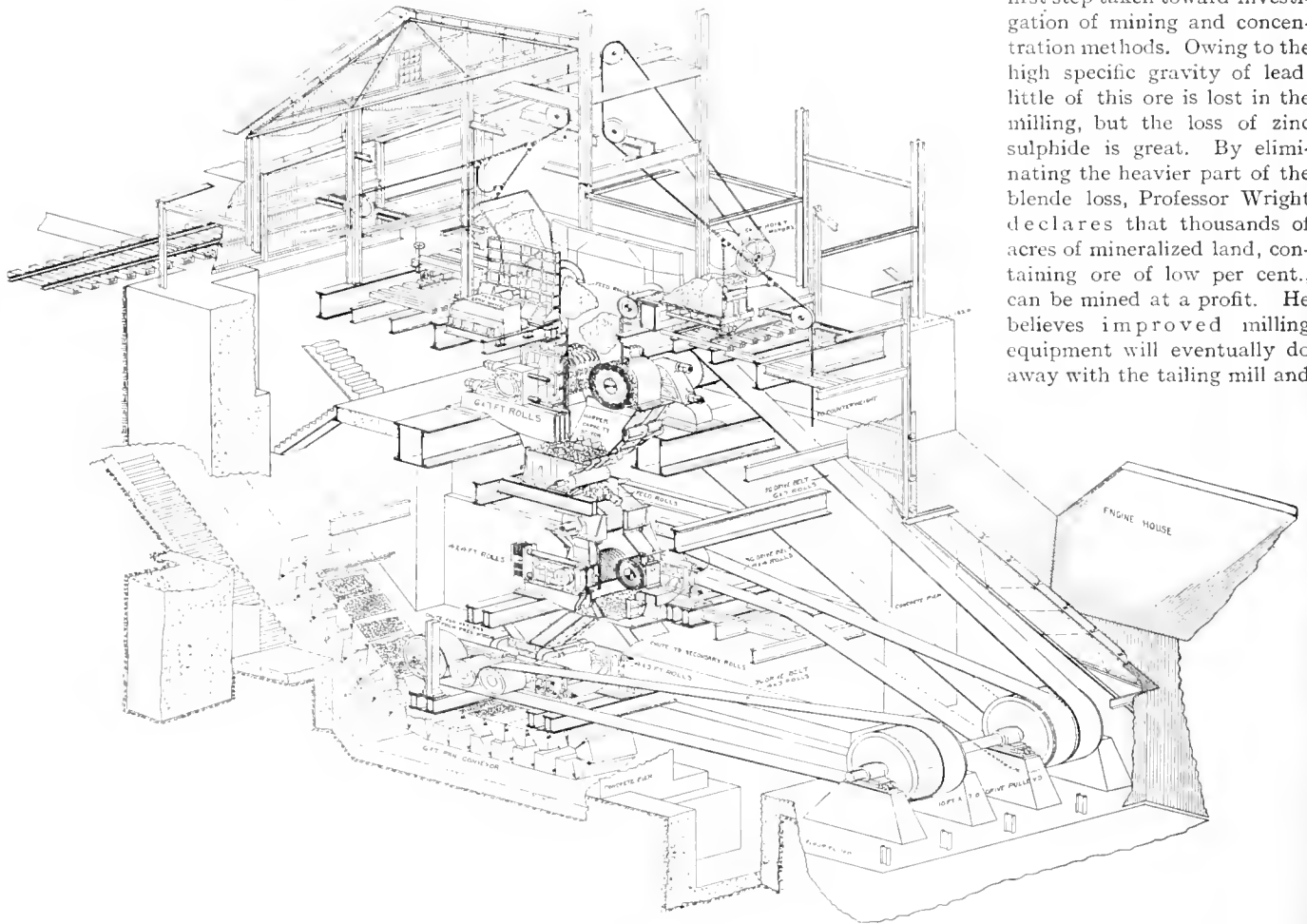

FIG. 3. TOMKINS COVE CRUSHING AND SIZING PLANT

As will be noted from the drawing, the stone is divided into three sizes, known as 1½-inch, ¾-inch, and ¾-inch stone. The finished product is carried by belt conveyers to bins having a capacity of 20,000 tons, from which it can be drawn and delivered by belt conveyers direct to barges on the river or to railroad cars.

來 來

The quantity of asphalt taken from Pitch Lake, Trinidad, which covers an area of 100 acres, during 1910 exceeded that of any previous year. At the present rate of operation the surface level is lowered about 6 inches a year. The depth of the deposit of asphalt over the center of the lake is unknown, as it cannot be sounded by rods, but the supply is supposed to equal the demand for many years; possibly it is inexhaustible.

Zinc and Lead Notes

Government to Aid of Operators.—C. A. Wright, representing the United States Bureau of Mines, is in the Joplin, Mo., district with the view of remaining until next June, his mission being to secure all data possible relative to mining and milling methods and costs and to offer advice and suggestions by which operators may reap a wider margin of profit from the handling of zinc and lead ores. The interest shown by the government in undertaking to improve local conditions is appreciated by the majority of operators who are aiding Professor Wright in his work. At the close of his stay in Joplin, Professor Wright intends to issue a pamphlet on his study of local conditions. While the government has made quite complete geological studies of the ore formations in the Joplin district, this is the

first step taken toward investigation of mining and concentration methods. Owing to the high specific gravity of lead, little of this ore is lost in the milling, but the loss of zinc sulphide is great. By eliminating the heavier part of the blende loss, Professor Wright declares that thousands of acres of mineralized land, containing ore of low per cent., can be mined at a profit. He believes improved milling equipment will eventually do away with the tailing mill and

will make it useless to try to work at a profit tailings that have once passed through a concentrating plant.

The Ore Market.—Talk of exporting zinc sulphides to Europe is heard on every hand. A. O. Ihlseng, who engineered the exportation of zinc sulphide to Swansea, Wales, in 1898, is trying to arouse interest in a similar move. He claims local ore prices are not high enough to warrant producers disposing of their output. Spelter, at East St. Louis, is strong, prices ranging between \$5.85 and \$6, while producers are experiencing difficulty getting what they think a fair price. According to the old "eight to one" basis that once prevailed throughout the district, 60 per cent. grades should be commanding \$47 and \$48 a ton. At no time recently, despite the fact that spelter climbed to \$6.05 not many weeks ago, has the price exceeded \$45 a ton, assay basis of 60 per cent. metallic zinc. From this

it has ranged down to \$38 in carload lots, and producers of smaller lots have received as low as \$30 a ton. Producers of calamine, on the other hand, have enjoyed phenomenally high prices, the basis offering for grades running 40 per cent. metallic zinc having ranged from \$22 to \$25, with choice lots commanding as high as \$32. Floods curtailed the calamine production in August and since then the buyers have experienced difficulty in securing enough ore to meet their demands. Shipments, of late, have averaged 700 tons weekly. Lead ore shipments continue strong and 1911 will be the banner year in

Sherwood mines in that locality, that section was considered a phenomenal producer of high-grade zinc blende. Following the suspension of work at the Sherwood, Thoms Station remained idle for years, little or no production coming from the district. Today this long-abandoned camp is producing more than 1,500,000 pounds of blende weekly, more than 50 per cent. of the total production of the Joplin camp. The chief producer is the Mexico-Joplin land, embracing several hundred acres, on which are situated the Mary C mine, the Katy mine, the Catharine mine, the High Tariff mine, all of which are mill propositions, and several smaller properties. On adjoining tracts are the Sitting Bull mine, the Modoc mine, the Big Irishman mine, the Little Israelite mine, the Federated mine, all mill propositions, and scores of rich prospects. The ore occurs in soft ground and in places runs 25 per cent. of the dirt milled. In

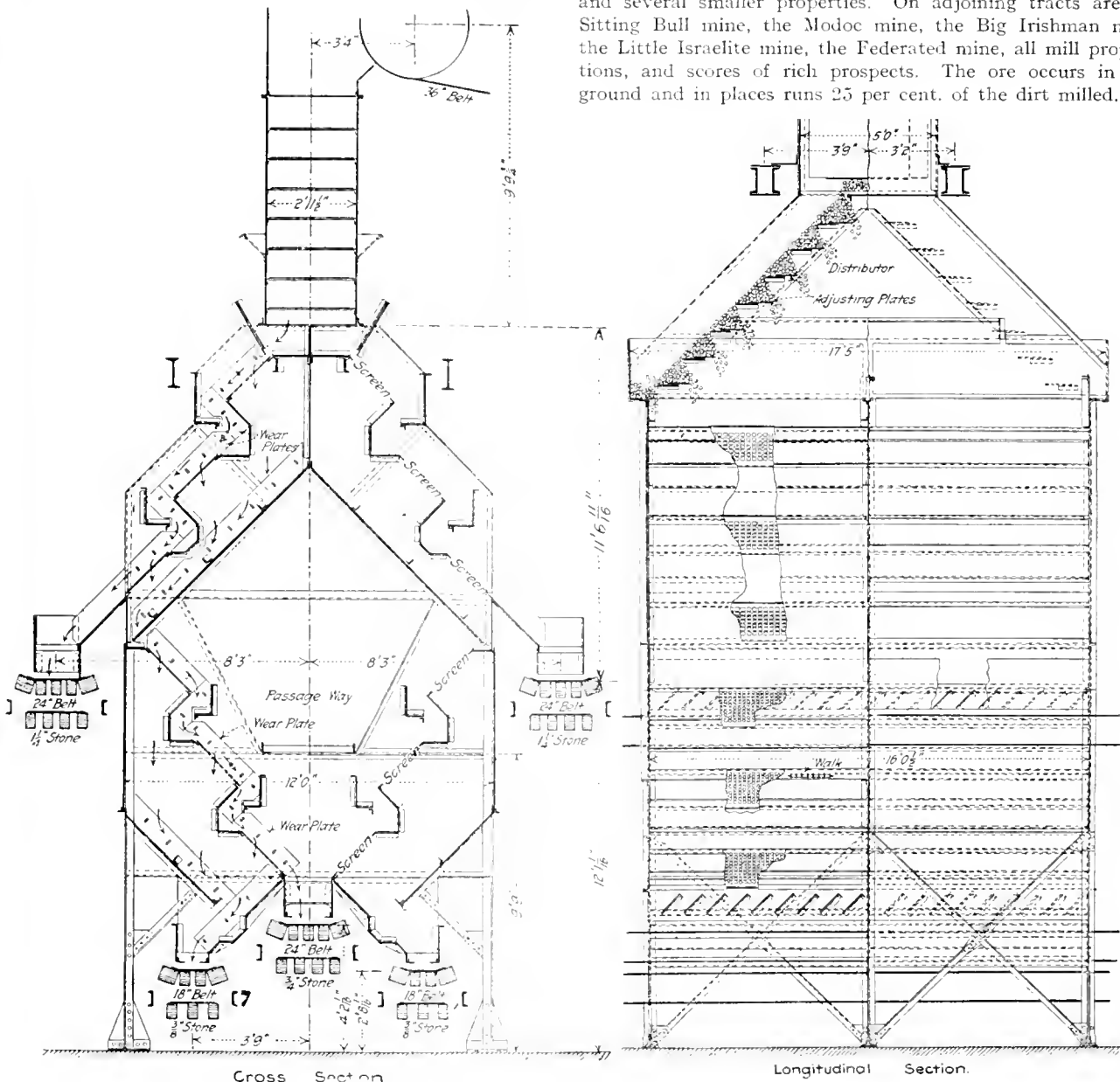

FIG. 4. DIAGRAM OF SCREENS, TOMKINS COVE PLANT

lead production in the history of the Joplin district. The aggregate value also will be the highest of any year in the district. The price has ranged from \$56 to \$63 per ton. Metal at East St. Louis remains strong, ranging from \$5.35 to \$5.45.

New Soft Ground District.—The ability of mining tracts to enjoy a second or even third period of productiveness, after once being thought exhausted, is one of the features that has distinguished the Joplin district, but never before has the truth of this condition been so unmistakably proven as in the case of Thoms Station, a "new-old" camp, several miles north of Joplin, Mo. A dozen or more years ago, in the days of the old

some instances the quality of the concentrates is lowered by the presence of iron pyrite, but the bulk of the ore will run close to 60 per cent. metallic content.

In the Spring City Camp.—Development in the Spring City district, south of Joplin, has been somewhat handicapped by the lack of transportation facilities, but despite this condition, some excellent strikes have been made on the land of O. D. Bittick, more than a mile west of the main portion of the camp, and in virgin territory. Marcum, Smith, Congdon, and Myers have a shaft into blende, lead, and calamine, at a depth of 156 feet, the strike verifying the drillings made several months ago.

Proposed Modification of the Square Set

Method of Timbering by Which Greater Resistance to Uneven Pressure is Attained

By A. J. Moore

The following paper, by A. J. Moore, describing a modification of the square set appeared in the Transactions of the Australian Institute of Mining Engineers.

When the writer first saw the square-set timbering, he was at once impressed with the fact that the frames made by the sets, along the lode and across it, were composed of panels with rectangular openings, and it was puzzling to understand how such a collapsible construction could resist pressure that came unevenly on it. Later he learned that the sets did not satisfactorily resist such pressure, but that filling had, to a great extent, to undertake this duty for them. So it appeared that the sets were practically an expensive scaffolding, enabling the miners to work in the face and carry the stope forward, till the filling was put in behind them to take the pressure of the roof and sides of the excavation. Of course some of the pressure is taken by the sets, but this is because the set timbers prevent the filling being done perfectly; if it were practicable to remove the sets before filling, the filling by itself would more effectively support the back and wall, than do the combined sets and filling. On the whole therefore the sets can hardly be said to be of much benefit where pressure has to be resisted. Despite this, the system has been of immense service in mining wide lodes, but for all that, it can only be pronounced a makeshift. This is no reflection on Deidesheimer, the famous originator of the square set, for, as will be shown later on, this way of using the square set was not his way, a fact of which the writer only lately became aware.

At odd times during the last few years, the writer has often tried to think out a way of applying the triangular principle to the sets, but, as it appeared necessary to do this along the lode, as well as across it, the problem was apparently quite insoluble; however, when the fact was properly appreciated, that the pressure strutways (along the lode) was usually insignificant compared to the pressures of the back, and hanging wall, the problem was simplified; and by treating the caps and legs as a series of frames supporting these two weights—to which frames the struts act merely as distance pieces—it was then seen that it was only necessary to triangulate these cross frames. This was done as shown in Fig. 1, by dispensing with the leg and substituting two diagonals.

There is of course nothing original in the triangulation principle that is applied, because (according to W. H. Storms) it is the principle that Deidesheimer adopted 50 years ago, in his first application of the square-set system. His manner of application, however, was different, as he secured the triangulation by putting a diagonal piece in every panel across the lode, and also had wall plates up the hanging wall and foot-wall, into which each frame, made by the caps, legs, and diagonals, was jointed. This jointing was very elaborate, and made the wall plates a most expensive matter. For this reason they have long since been discarded, and, in addition, the systematic use

of the diagonals was dropped. These deprivations greatly weakened the frames, and it was soon learned, from disastrous experience, that the sets could not stand without the aid of filling. But it is proved sufficiently that the principle applied by Deidesheimer was the right one, by the fact that the big stope, which was from 60 to over 100 feet wide and several hundred feet long—timbered under his personal supervision at the Ophir mine—was not filled till it had reached the great height of 400 feet. It was only a phenomenally rich stope such as this, that could bear the expense of such elaborate timbering; and unsatisfactory as is the present system of skeleton sets—plus filling—it must be a considerably cheaper method.

The writer believes that his way of applying the principle combines the strength of the Deidesheimer system with the cheapness of the later method, and has additional advantages of strength and convenience due to the fact that the diagonals are in two directions.

Before going into the details of the proposed construction, it is interesting to notice the effect the triangulation principle has on the frames. Fig. 2 represents a cross-section of a stope timbered: (a) With the ordinary square set; (b) with the

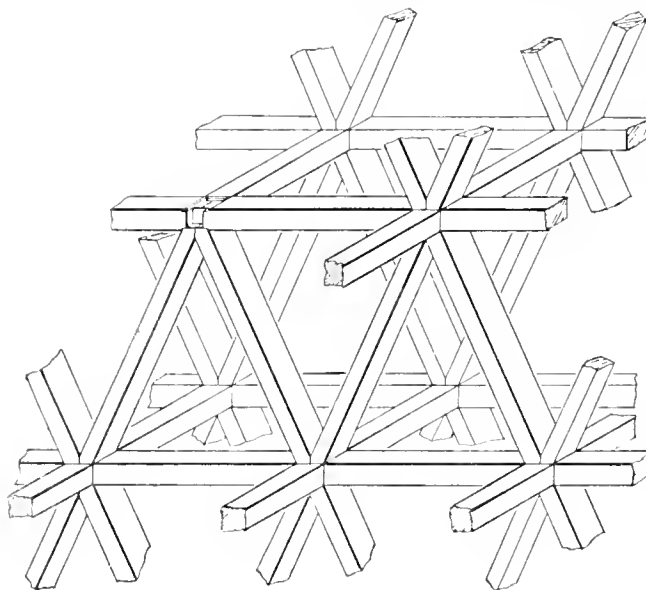

FIG. 1

proposed modification of the square set; (c) with the Deidesheimer sets; *M* is a loose cylinder of rock whose weight comes on the corner "A" of a set in each case.

In case (a), this weight will be supported by the line of caps *AC* and line of legs *AB*. All the other members of the frame, being at right angles to one or other of these, are unable to give any assistance to them.

In case (b) the weight is supported as before by *AC* and *AB*. In a high stope, it will be seen that in this case *AB* will get to solid support on the foot-wall in a much shorter distance than in case (a). But there is more in it than this. Suppose for some reason that any link—say *mn*—of *AC* or *AB* fails. The pressure along *Am* would then be split along *mp* and *mq*,

and similarly at *p* and *q* there are three members that are capable of sharing the stress, and if these ramifications are followed up, it will be found that every member of the frame can share in the stress applied at *A*.

In case (c) similarly, all the members enclosed between *AB* and *AC* and the foot-wall can share the stress. But the members above *AC*, and on the hanging wall side of *AB* are not able to lend any assistance.

Where an isolated weight from the back comes on a joint, the superiority of the proposed construction is further demonstrated. In case (a) the line of the legs directly under the weight, alone supports it. In case (b) every member as before shares the stress. In case (c) all the members on the hanging wall side of the line of legs immediately below the weight do not give any assistance.

In fact it almost appears in case (b) as though the weight of the hanging wall and the weight of the back becomes mutually supporting, and possibly it would be found that when these pressures come unevenly on the various corners of the sets, the stress is, however, distributed evenly over the frame. In any case it is apparent that the form of construction of (b) has great superiority in strength and stability over that of case (a) and in a lesser degree over that of case (c).

The proposed construction of the set is shown in Fig. 1

The caps and struts are of 10"×8" timbers, the diagonals of 10 in.×6 in., all of them put in with their wider sides downwards. The angle of the diagonals may be whatever best suits the particular case to be dealt with. Properly speaking the angle should correspond to the angle of the hanging wall, but in practice this will not always be convenient. The angle the diagonals in the figure make with the horizontal (and which the writer thinks will be found suitable to most cases) is 65 degrees. Taking the center lines of the caps as 8 feet apart vertically, this will give a cap length of 7 feet 6 inches; strutways the caps are 5-foot centers, 6 feet would not be perhaps too much, but it gives too great a span between the drive sets.

The joint is of course the vital part of the set; but before going into that question, it is as well to point out one or two things about the present joint. Fig. 3 is an isometric projection of this joint; it is designed to resist top pressure mainly. In America this form is seldom used, and in that country the joint has been greatly varied by different fields to suit local requirements. With the joint shown in Fig. 3 the leg becomes the weaker member of the set, whereas it should be the strongest; whilst the strut is the strongest, though it should be the weakest. It is in the 4"×4" spill that the leg is weak. If the face be heavy, it is necessary to put in face boards whose ends press on the legs, and if there be much weight on the boards there is only the strength of the 4"×4" spill in resistance, and a breakage in such a case is fairly common. Similarly, when a rock is blasted from the face against the leg, there is only the 4"×4" spill to resist breakage. In the former case it is often necessary to put under the cap a 10"×2" or 10"×4" liner whose ends bear against the full width of the legs. In the case of the cap, a liner is also often necessary when a heavy back weight comes on it; the 1-inch hold the cap has (at the sides of the spill) on the shoulder of the leg is not sufficient as that part of the top of the leg will chip away, and the cap tends to sink into the leg.

Fig. 4 (a) is a projection of the proposed joint. As the top pressure becomes translated partly into side pressure, and vice versa, there is no need to design the joint to resist either in particular. It is convenient to have the caps butting against one another. This is done by spills of 5 in.×5 in. section and 3½ inches deep. The strut spill is 7 in.×5 in. and 2½ inches deep. These dimensions allow the ends of the diagonals to be housed in for a depth of 1½ inches. The area of the faces of the diagonals pressing against one another is 10 in.×5 in. The cap has a bearing surface for its full width of over 2 inches (taking in the bevel) on the diagonal, in addition to its spill bearing. The cap's full depth also bears against the strut shoulder practically for 1½ inches. It will be seen, therefore, that the cap has its full section to depend on for a blow from the face, or for any weight on its top side. Similarly the diagonal opposes a section of 10 in.×5 in. area to the side weight; this section has about eight times the strength of the 4"×4" spill section. It will be seen also that the caps and diagonals are edge on to the face and can stand a heavier blow than if lying the other way. Further, if there is any tendency of the diagonals to crush the joint (which is unlikely, as the pressure cannot be concentrated on single lines as in the ordinary set), this across-grain pressure becomes to a great extent translated into a pressure along the grain, by means of the beveled face on the cap. The strut spill is not so strong as in the square-set case, but is strong enough.

This joint will be more expensive to cut. The diagonals are simpler and cheaper to cut than the legs, but the strut is a little more expensive, and the cap more so. The writer believes that the increase of expense will not be very marked, and will by no means counterbalance the advantages of the joint.

A cheaper form of the joint is shown at Fig. 4 (b). This gives a strut spill of 8½ in.×5 in., but reduces the full width bearing of the cap on the diagonal to the beveled surface, which is, however, over 1½ inches in depth.

Two more variations of the joint can be got by making the cap spill 6 in.×6 in. section in these two cases; this will reduce the depth of the strut spill from 2½ inches to 2 inches and the housing in of the diagonals to 1 inch, and will increase the thickness of the strut spill to 6 inches.

In practice the most suitable joint would soon be evolved.

The drive set is shown in Fig. 5. Its form is arrived at by simply removing two of the diagonals and putting a 10"×10" upright under each end of the cap and afterwards lining with 10"×10" timber the underside of the diagonals as shown, the outside of the drive being lagged with 10"×4" timber. It may be pointed out here that the vertical load of filling on these 10"×4" timbers will be less than half what it would be if they were lying flat.

On the drive cap and two legs, the pressure is nearly all along the grain, though there is a bending moment on each of them, but in each case near to the point of support. The crushing on the cap ends, however, is likely to be severe, and for this reason it would be preferable to have the cap of hard wood. It will be seen that a good deal of any necessary repairing could be done without interrupting the traffic, and room also is left for further reinforcement of the sets if required. In putting in this drive set it would not be done all in one stage. Probably, in standing ground, the sill with the legs and cap (or internal set) would be put in first and the 10"×4" lagging laid on the top for the time being. Later, the two diagonals would be added at the side and lagged with 10"×4" timbers and, when the second floor of sets was being put in, the upper part of the drive would be put in and lagged, and the lining with 10"×10" timbers done when desired. In heavy ground a somewhat similar method would be adopted with driving laths, probably in the place of the temporary 10"×4" timbers on the caps.

In Fig. 6 is shown a way of putting in the sets, where the wall is vertical, or where a pillar is left. At every second floor a half cap will be put in, its spill on the pillar end being a plain

5"×5" spill to accommodate the top of a 10"×5" or 10"×4" upright, and 10"×5" or 10"×4" struts as shown (the office of these 10"×5" timbers being mainly to keep the end of the cap up to its work). The 10"×5" uprights will fit into the spill of the 10"×8" struts above and below the half cap; all these joints being well blocked against the ground.

In the case of pillar, the filling could then be done in the manner of the Broken Hill Proprietary mine, by laying, as the filling rises, 5"×2" paddock laths (3 inches apart) horizontally with their ends against these 10"×4" uprights and, for residue filling, putting waste candlebox pieces and sawmill slabs to block the 3-inch openings. An advantage of the sets is that the chutes can be put in on the slope, or vertically, as desired.

For working the sets in the admirable method, used so extensively in the Broken Hill Proprietary mine, of hanging the sets from a boom and stoping underhand, there is to the writer no apparent difficulty. The difference would be that

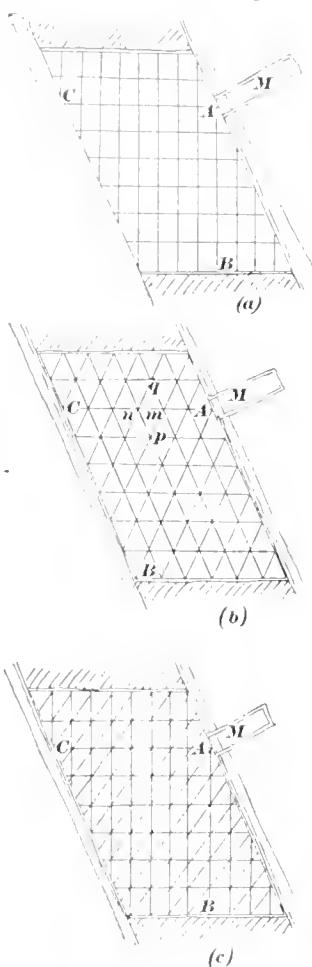

FIG. 2

the sets will be carried down on a rill, and in running ground this would be rather an advantage. There would not be so much weight on the boom as in the case of vertical sets.

To arrive at the amount of timber used by the proposed set, the writer took a space 24 ft. high \times 30 ft. \times 30 ft. and calculated the amount of material required to timber it in the case of the 7' \times 6' \times 5' square set, and the 8' \times 6' \times 6' square set with 10" \times 10" timber; and the proposed set with 7-foot 6-inch caps, spaced 8-foot centers vertically and 5-foot center strut-

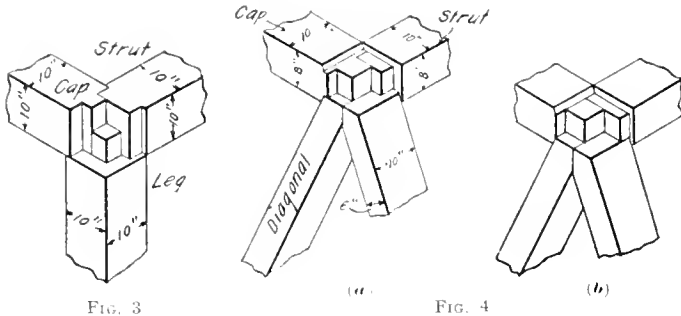

FIG. 3

FIG. 4

ways, caps and struts of 10 in. \times 8 in. and diagonals of 10 in. \times 6 in. with the following result:

	Equivalent Length of 10" \times 10" Timber Required Feet	Amount Used in the Frames Across the Lode Feet	Percentage Used in the Cross-Frames Per Cent.
Square set, 7 ft. \times 6 ft. \times 5 ft.	1,850	1,340	72½
Square set, 8 ft. \times 6 ft. \times 6 ft.	1,500	1,050	70
Proposed set.....	1,483	1,200	81

It will be seen that, in comparison with the most favorable case for the square set (and making no allowance for diagonals, liners, etc., in the square set case) the proposed set uses about 1 per cent. less timber, but has 14 per cent. more timber in its cross-frames, where it is most required.

In conclusion, the writer admits the slight extra expense of cutting the timbers for the joint, and also foresees some slight difficulties in using the set, but these, he expects, will in practice be easily overcome. On the other hand he believes that the

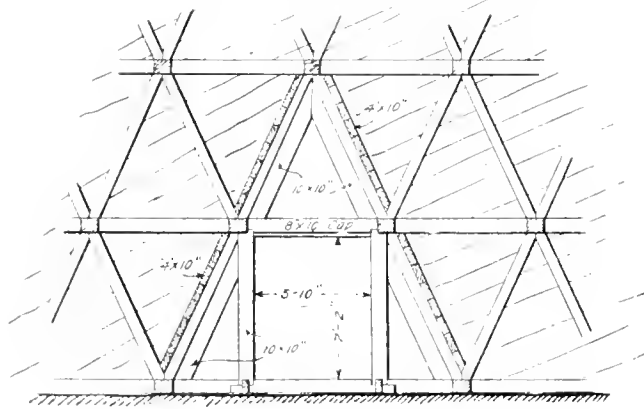

FIG. 5

proposed modification may be said to have the following advantages:

- (1) Far greater strength, without any more timber being used.
- (2) Much greater stability under uneven pressure.
- (3) Filling will not be required in many cases.
- (4) Where filling is required, it can be done more cheaply because the face can be carried forward much further in advance of the older filling, and so the newer filling can be put in, in greater quantities at a time.

(5) It is stronger than the Deidesheimer set, which was admittedly much stronger than the present set.

(6) It has a flexibility of application, as the angle of the diagonals can be varied to a certain extent.

(7) The joint is much stronger than the present joint.

(8) A much stronger drive set can be used with it.

(9) Chutes can be put in more conveniently.

(10) It has a greater proportion of its timber in the frames across the lode.

(11) The timbers are lighter to handle.

采 采

Mining Regulations in China

In a recent United States Consular Report, Consul General Bergholz, of Canton, gives the following facts in regard to mining regulations in that country:

Mining in China has been handicapped by fees, royalties, transit, likin, and export charges, etc., imposed upon the output of mines by the central government. Mines are not to be opened until there has been obtained from the Board of Commerce a permit to prospect and a permit to operate. Mining concessions must not be over 30 square li (li = ¼ mile) in area and the length may not be more than four times the width. Should there be graves upon the land included in the concession, care must be taken in sinking shafts to avoid them, and when such avoidance is absolutely impossible a liberal allowance must be made for removing the graves. The permit to prospect allows merely an examination of the surface outcrop of the vein, and such examination "must not be carried to too great a depth or over too great an extent of ground." Foreign capital may be admitted to only equal shares with Chinese capital in any original mining enterprise.

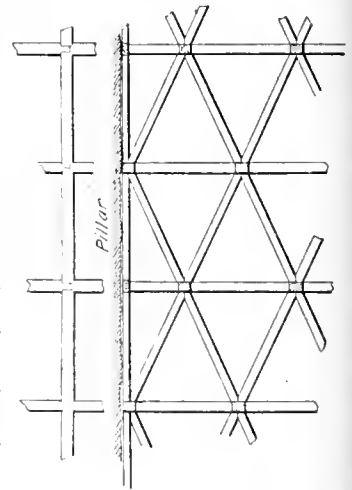

FIG. 6

Should a company consisting solely of Chinese capital find its funds too limited to conduct the undertaking properly, it may raise a foreign loan upon the security of its machinery and plant, but it can not mortgage the mine for this purpose. The ordinary land tax must be paid on all private land affected by a permit to prospect. Public lands affected by such a permit shall pay an annual rental of 1 kuping tael (67 cents) per mow (⅓ of an acre). The fee for a permit to prospect is established at \$33.50 and before prospecting may begin one year's rental on all government land thereby affected must be paid. The fee for a permit to work a mine is established at \$67 for any area of 10 square li or less, and for every additional square li, \$6.70. A tax must be paid on the gross output of all mines as follows: (1) Coal, antimony, iron, alum, and borax, 5 per cent. ad valorem; (2) petroleum, copper, tin, lead, sulphur, and cinnabar, 7½ per cent.; (3) gold, platinum, silver, mercury, and zinc, 10 per cent.; (4) quartz crystal and all sorts of precious stones, 20 per cent. Export duty must be paid on all ore or minerals exported, according to the customs regulations. Upon receipt of a permit to prospect, a bond of 5,000 taels (\$3,350) must be filed, and on receipt of a permit to work a bond of 10,000 taels (\$6,700) is required by the authorities.

When to these provisions of the law are added the long and complicated process by which such permits can alone be obtained, and the numerous and indefinite but necessary payments involved therein, the difficulties encountered by mine operators in China are apparent.

Parral Tank as a Slime Agitator

Details of Construction and Method of Operation Compared with Pachuca Tank

During the San Francisco, Cal., meeting of the American Institute of Mining Engineers, in October, 1911, Bernard MacDonald, of Pasadena, Cal., presented a paper on "The Parral Tank System of Slime Agitation." The paper announced a new and improved system of slime agitation which Mr. MacDonald has devised and patented, and which is in operation at the Veta Colorado M. & S. Co. cyanide mill, Parral, Mex. The following is abstracted from that paper:

Agitation is an essential part of the treatment of slime in cyanidation, for by agitation the solids in the slime pulp are kept in suspension and mixed with a solution in the proper proportions required for the treatment. If the proper weight of solution to solids be determined as two parts by weight of water to one part of dry ore, which is approximately 5 to 1 by volume, this proportion should be maintained in every part of the charge; that is, each solid particle of the pulp, whether it be 180- or 400-mesh size, should be surrounded by five times its own volume of solution throughout the whole period of treatment. The reason for this is that the quantity of chemicals necessary for dissolving the gold and silver contained in the slime is held in uniform solution, and therefore the determined portions of solutions and solids must be maintained at all times during treatment. For, if the pulp should be allowed to thicken at the bottom of the tank so as to contain say only four parts by volume of the solution to one part of solid, there would be only four-fifths of the chemicals present in this part of the tank charge, while the other one-fifth would be present in another part of the tank charge where it was not required. Besides maintaining the proper proportional mixture of solution and ore, agitation is designed to furnish aeration to the slime pulp during treatment. The superior economy of air-lift agitation, or the Pachuca tank system of slime agitation, and the energy of the patentee of this system, soon brought this method into popularity and most of the recently constructed cyanide plants have adopted it.

Figs. 4 and 5 respectively show standard Pachuca and Parral tanks of approximately equal holding capacities. The corresponding items in the two tanks are as follows:

	Pachuca	Parral
Height in feet.....	45	15
Diameter in feet.....	15	25
Horizontal area in square feet.....	176.7	490.8
Effective holding height in feet.....	39	14
Holding capacity in cubic feet.....	6891.2	7671.2
—Holding capacity in Metric Tons—		
Pulp: Solution 2, Solids 1.....	83.38	92.8
Pulp: Solution 2, Solids 1.....	139.5	155.3

As may be seen from Fig. 4, the Pachuca tank is a tall cylinder *a* having a cone bottom. In the center of the tank is fixed the air-lift tube *b*, which, commencing about 18 inches from the apex of the cone bottom, extends to within a few inches of the top of the tank. The diameter of this tube is proportioned to the diameter of the tank, approximately as 1 to 12.

The explanation of the pipe equipment in Fig. 4 is as follows: *a* is the side of the tank; *b* is the air-lift tube; *c* is the pipe which delivers the compressed air into the bottom of the air-lift tube; *d* is the foot-rest which holds the compressed-air pipe in the center of the air-lift tube; *e* is an auxiliary compressed-air pipe used for delivering compressed air at the bottom of the tank to keep the pulp in agitation while the charge is being received; *f* is a system of pipes extending radially from a hollow "bustle" or distributor attached to the air-lift tube to which is connected a feed pipe leading from the air main at the top of the tank, through which compressed air or solution under pressure may be turned into the bottom of the tank to assist in agitating the pulp while the tank is being charged, or to restore the pulp, in case of packing, to a fluidal consistency so it can be transferred through the air-lift tube.

The compressed air, high-pressure solution, and pulp charging mains for the pipe connections are shown at the top of the tank. It should be noted that the end of the compressed-air pipe *c* is capped, and for a length of about 7 inches above the cap is perforated by a number of small holes through which the compressed air escapes into the air-lift tube. To prevent the pulp from entering these holes and choking the pipe when the compressed air is shut off, a tight-fitting rubber stocking or tube is drawn over the holes and clamped to the pipe above them. When the air is on, the stocking expands and the air flows underneath it and escapes at its lower end, which is left open. When the air is shut off, the stocking closes over the perforations and prevents the pulp from entering them.

In operation, when the tank is receiving its charge from the pulp-charging main, compressed air is turned on through pipe *c* to keep the pulp in agitation and prevent it from settling in and around the bottom of the air-lift tube. In case the compressed air fails during the charging of the tank and the pulp packs around the bottom of the air-lift tube and the rubber stocking, so hard as to prevent the operation of the air lift when the compressed air comes on, air or solution, or both, may be turned into the auxiliary pipes *e* and *f* to bring back the packed pulp to fluidal consistency, and, in case this fails, the tank is provided with a manhole shown in the figure, which may be opened and the packed pulp excavated. When the tank has received its full charge of pulp, com-



FIG. 1. TRANSFER PIPES IN TANK

pressure is turned on in pipe c, which starts the operation of the air-lift tube, and the auxiliary-air agitation pipes are then closed. At the operation of the air-lift tube the thick pulp at the bottom of the tank is drawn into and carried up through it and discharged at the top where it falls back on the tank charge and mingles with the thin pulp there.

The transfer of the pulp from the bottom to the top of the tank continues throughout the treatment period and preserves the proper proportional mixture of solution and solids. By these means and in this manner the agitation of slime pulp is effected by the Pachuca tank system.

All defects in the Pachuca tank system result from the design of the tank and the apparatus with which it is equipped. Its great height and small diameter make its holding capacity comparatively small, and consequently its cost of construction per unit of holding capacity high. The height of the tank and the large diameter of the air-lift tube necessitates a corresponding high pressure and large volume of compressed air to effect the transfer of the pulp, which adds to the cost of agitation.

The pulp transferred through the air-lift tube overflows

agitation of such charge should be 10 per cent. greater, or say .60 pound for each foot in height of tank charge. When the compressed air of .60 pound foot pressure is turned on in the air pipe terminating near the bottom of the lift tube, it flows into the pulp there which only has a pressure of .54 pound per foot in height. The compressed air on entering the pulp in the lift pipe assumes the form of bubbles, which, rising through the pulp, immediately join together, forming a large flattened bubble which, extending to the sides of the pipe, takes the form of a disk or piston, in which form it rises to the surface, pushing the pulp before it. Rivalry now begins between the pulp and compressed air for the privilege of filling the space being vacated by the ascending air disk. The pulp, endeavoring to restore the hydrostatic equilibrium between the contents of the air-lift tube and the tank outside, and, by reason of its greater volume owing to the disparity of size between the compressed air and air-lift tubes, rushes past the air nozzle holding back the issue of air, momentarily. But, immediately, the air on account of its higher pressure, again succeeds in entering the lift tube in sufficient quantity to form another air disk with the same result as before. Thus, by jets of compressed air alternating with rushes of pulp of great frequency into the bottom of the air-lift tube, the lifting operation is effected.

It is not improbable, however, that in certain kinds of liquids having great viscosity, the inflow of compressed air would be imprisoned in it as numerous small individual bubbles, and would, in this way form an emulsion of the liquid within the tube, and this being lighter than the pulp outside, would be lifted or shoved upward by the heavier pulp coming in to displace it. But this condition would not be probable in the case of an ore slime.

Regarding the defects of the air nozzle of the Pachuca tank, the principal one is the amount of ineffective work that must be done by the compressed air in making its numerous jet-like escapes into the air-lift tube. The superficial area of the exterior of the rubber stocking that must open and close for each jet of air escaping, is 36 square inches at least, and on each inch of this area there is a continuous pressure of .54 pound per inch per foot in height of the tank charge. As filled in operating, there are 43 feet of pulp in the tank which makes an external pressure

of 23.22 pounds on each square inch, or a total of 836 pounds on the movable part of the stocking, which weight must be lifted by each jet of air admitted to the air-lift tube. Owing to the great frequency of the air jets the enormous amount of useless work which this form of valve necessitates will be apparent. The numerous alternate openings and closings of the rubber stocking soon destroy its elasticity and wear it out.*

It should also be understood that the efficiency of air pumping is affected differently from that of mechanical pumping. For instance, a mechanical pump designed for a 6-inch discharge pipe will pump as easily the same quantity through a 16-inch discharge. But in case of air-lift pumping, the volume and pressure of compressed air that would be sufficient to pump violently through a 6-inch discharge pipe will have no lifting effect, whatever, through a 16-inch pipe; for the compressed air would rise in a stream of separate bubbles through the liquid in the lift tube, and would be not of sufficient volume to form

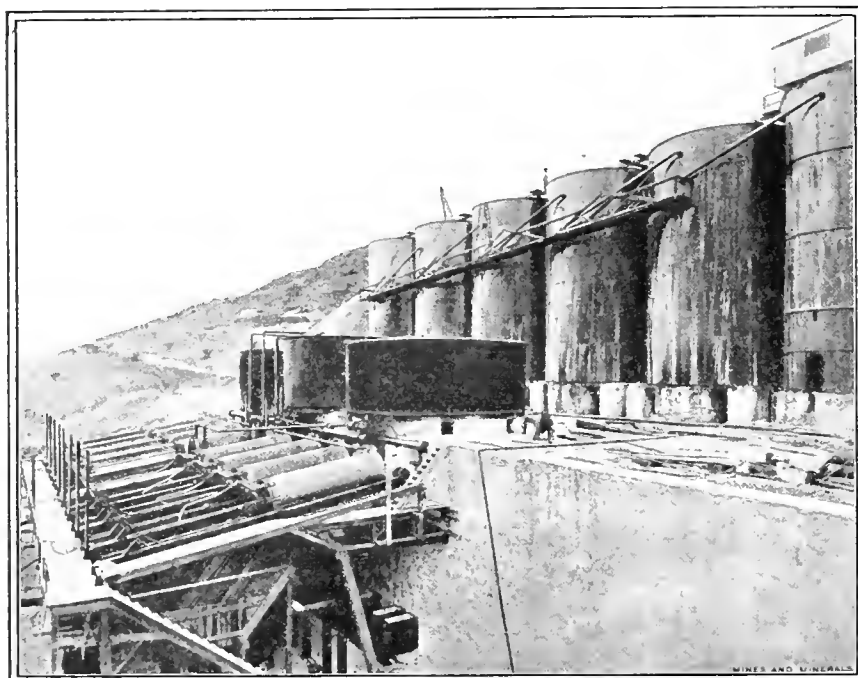

FIG. 2. PARRAL AND PACHUCA TANKS

on the top of the charge close around the tube, in which relative position the solid particles settle vertically to the bottom, where the steeply sloping sides of the cone bottom carry them to intake of the lift tube, which throws them back again on the top of the charge. Under normal conditions of operation, the air-lift tube turns over the entire charge in a Pachuca tank of standard size in about 15 minutes. The violence of this operation would not be necessary to keep the pulp in proper mixture, but, on account of the tall narrow tank and the cone bottom it is necessary, in order to keep the air-lift tube and the air nozzle from being choked.

The air nozzle within the lift tube is a crude mechanical device, expensive to operate and expensive to maintain.

Before the reasons for these assertions are submitted, the principles of air-lift pumping should be reviewed.

At the starting of agitation, after the tank has received its charge, the pulp level is the same within and without the air-lift tube, which extends say 3 or 4 inches above the pulp level. If the pulp has the consistency of 2 to 1 of solution and solids, the pulp pressure on the bottom of the tank will be .54 pound for each foot in height of tank charge. The air pressure for the

*The difficulties attending agitation in Pachuca tanks are described by Huntington Adams, in a paper read at the Wilkes-Barre meeting of the Institute, June, 1911, and need not be repeated here.

solid air disks that would reach from wall to wall of the lift pipe, and the liquid column would be unbroken and maintain itself in hydrostatic balance with that outside the lift tube and no displacement would result. This points to the economy of using the smallest air-lift tube consistent with the volume of liquid to be pumped.

In the Parral tank system of slime agitation, which was designed and developed by the writer, and for which United States and Mexican patents have been obtained, the defects in the Pachuca tank system, above referred to, have been eliminated and corresponding advantages secured.

A complete tank equipment of this system having the capacity of treating 500 tons daily, and consisting of five tanks, has been installed at the milling plant of the Veta Colorado M. & S. Co., at Parral, Mex. Along with the Parral tanks are installed two of the standard Pachuca tanks, one of which is used as a treatment tank and the other for holding the wash water for the filter-press plant.

The Parral tanks are equipped with the special piping and the apparatus peculiar to this system, while the Pachuca tank is equipped with the piping and apparatus common to that system. The treatment tanks, that is the one Pachuca and five Parral tanks, have been piped for individual and continuous systems of treatment, and each of these systems has been tried out separately and a complete record of the results carefully kept. No advantage has been shown in the extraction of values by either of these systems over the other, but the continuous system is more economically operated by reason of its great simplicity and fool-proofness.

Fig. 2 shows the battery of treatment tanks, the Pachuca tanks being on the extreme right, on top of which is the deck house used for the titration of samples, while in the same row and to the left, are the five Parral tanks. Along the front of the tanks near their tops is seen the piping for the continuous-treatment system, and the sampling platform. In the center and lower left corner are shown the 'excess' tanks and the battery of Kelly filter presses appurtenant to the plant.

The object of the Parral tank system of agitation is the same as that of the Pachuca tank system, but the tank design and the mechanical equipment are entirely different from that of the Pachuca system.

The Parral tank is flat bottomed, 25 feet in diameter and 42 feet in height with a capacity two and a half times as great as the standard Pachuca tank. For raising slime pulp from the bottom to the top of the tank, four transfer pipes *a*, shown in Fig. 5, are installed, each 12 inches in diameter and set 12 inches from the bottom and 4 feet from the tank side and equidistant from each other. The compressed air is admitted into these pipes through a patented nozzle fitted with a ball valve, which automatically opens and closes, intermittently, as required in the jet feeding of the compressed air.

In case the compressed air should fail, and in the momentary intervals between the jet issues, the air nozzle is securely and automatically sealed by the ball *a*, Fig. 7, falling back on its seat, and the entrance of the pulp to the air pipes is prevented.

On the delivery or top ends of the transfer pipes, tees of equal diameter are bolted with the run in line with the pipes and the outlets so directed as to discharge the pulp in line of segment cords to the circumference of the tank. The discharge of all the transfer pipes is in the same direction, and the force of the discharge sets up a spiral or rotary flow in the tank

charge which in a short time extends down to the bottom of the tank.

Fig. 3 shows the pulp discharging from the transfer pipes and the undulations of the rotary flow set up in the tank charge. When Parral tanks are receiving their charge for individual-charge treatment, an auxiliary air pipe is extended down alongside each transfer pipe to a point near the bottom of the tank, and the compressed air issuing from these pipes keeps the pulp in agitation and prevents its settling on the bottom. In the continuous system this pipe is never used.

When the tank is filled to within 10 or 12 feet of the top, the air is closed off the auxiliary pipes *b*, Fig. 5, and turned on within the transfer pipes. Fig. 4 shows a workman making this change and the transfer of the pulp (lift at this time) commencing. This illustration also shows the method of fastening the transfer pipes fast to the tank in a secure and simple manner.

The spiral flow set up in the tank carries the pulp particles round and round, so that the distance traveled by the pulp from the time it is delivered at the top until it reaches the

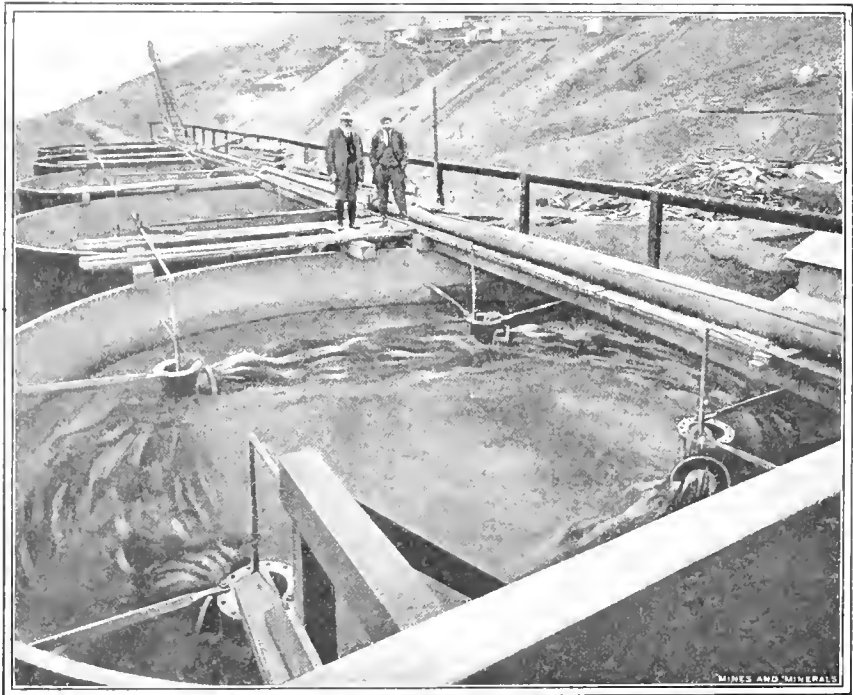

FIG. 3. ROTARY FLOW IN TANKS

bottom, is many times greater than if it settled vertically, as in the Pachuca tank. The solids carried in suspension by the rotary flow of the solution and their settlement thus retarded, the necessity for frequently transferring the pulp from the bottom of the tank to its top is lessened and the cost of the work compared with the Pachuca tank reduced.

In the Parral tank system no special diameter of tank need be adhered to as in the Pachuca system. The relation of the diameter to the height of the tank may be whatever is economical in holding capacity, which should be the main consideration in designing tank diameter.

To secure perfect agitation and the necessary rotary flow in tanks of 30 feet or more in diameter it would be necessary to install a proper number of transfer pipes with the discharge outlets placed so as to set up and maintain the rotary flow.

The compressed-air nozzle with its ball valve, which may be used in any air lift, makes for the highest possible efficiency of compressed air used as a lifting agency. Fig. 7 illustrates the construction and operating methods of the ball valve. An analysis of the operation will show that the pressure on the ball due to the hydrostatic head of the pulp charge, is balanced,

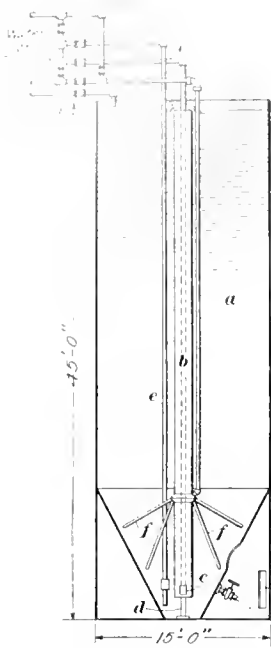

FIG. 4. PACHUCA TANK

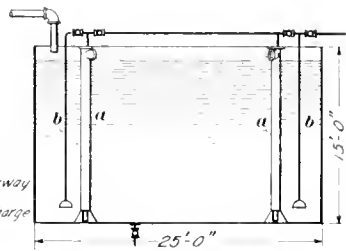

FIG. 5. PARRAL TANK (Same capacity as Fig. 1)

except for that area of the ball which rests on the seat. The seat area of the valve which is 2 inches in diameter (equal to a horizontal area of 3.1416 square inches), leaves an unbalanced weight of 73 pounds on the ball, if it were to replace the rubber stocking in the Pachuca tank, or 763 pounds in favor of the ball valve.

As the air nozzle is called upon to open and close several times each second in permitting the jet discharge of compressed air into the transfer pipe, the aggregate of the useless work the rubber stocking imposes on the compressed air, and the comparative advantage which the ball valve possesses over it, will be easily estimated. The reason for stating that the probable frequency of the air-jet discharge will amount to several each second is that the sound of the seatings of the ball valves, as heard by one going underneath the tank, seem almost as frequent as the blows of an air hammer.

For comparison between the life of the two kinds of valves, the Panilla mill is taken, where equipment includes 12 standard Pachuca tanks, 10 of which were equipped with the rubber-stocking valve and two with the nozzle and ball valve. These tanks began operation on January 1, 1911. The rubber stockings soon wore out and were replaced by Parral valves while the original Parral valves are apparently as good as when first installed. In this plant and in that of the Veta Colorado M & S Co. the Parral valves never gave any trouble in starting up, even after the air had been closed off for 3 hours at a time, while under the same conditions the valves of the Pachuca tanks were only started after a great amount of trouble.

Although the transfer pipes in the Parral tanks are 12 inches

in diameter, probably pipes 8 inches in diameter would produce sufficient rotary flow in the tank charge to give the required agitation. When the transfer of the pulp is started and a strong rotary motion (about 6 feet per second) communicated to the charge, the air valve is partly closed until the flow of

TABLE I. PACHUCA AND PARRAL TANKS COMPARED

Points of Comparison	Dimensions or Number	
	Pachuca	Parral
Height in feet.....	45	42
Diameter in feet.....	15	25
Area of bottom of tanks in square feet.....	176.7	490.8
Holding capacity for each foot in height, cubic feet..	176.7	490.8
Number of air lift or transfer pipes.....	1	4
Diameter of each air-lift pipe in inches.....	16	12
Total cross-sectional area of air-lift pipes, square inches	201	452
Diameter of each compressed-air pipe in lift pipes....	1 1/2	1
Total cross-sectional areas of air pipes in lift tubes....	1.7671	3.1416
Proportional area of tank bottom for each square inch of cross-section air-lift tubes, square feet.....	.8	1.8
Area of tank bottom for each square inch of compressed air pipe, square feet.....	100	156

pulp from the transfer pipes is reduced to one-third of their normal capacity and so continued to the end of the treatment. From repeated tests, it has been shown that the extraction of gold and silver was equally as good under these conditions as when they were being operated at full capacity. From these tests

it has been deduced that so long as the spiral flow in the tanks is maintained at a speed sufficient to materially retard the vertical settlement of the solids the extraction of gold and silver proceeds just as rapidly as when the pulp is violently agitated.

There are no exact data from which to estimate the comparative amount of air consumed per ton of pulp treated in the two systems, for

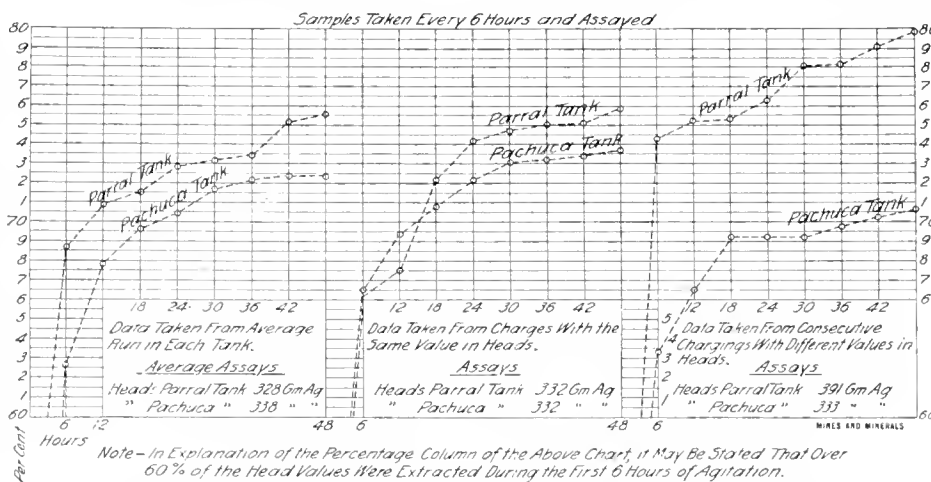

FIG. 6. RECORDS OF REGULAR OPERATIONS OF PARRAL AND PACHUCA TANKS
Chemical Constituents of Solution KCN, 15 per cent.; Protective Alk. dimity, S50 Gm.; Lead, 3 Gm.
Physical Condition of Pulp: Dilution 2 to 1; Specific Gravity 1.26; Screen Sizes +200, 15 to 20 per cent.; -200, 75 to 80 per cent.

the air has never been metered, but engineers who operated the valves on the air pipes of both tanks experimentally, with a view of estimating the flow of air, by the proportional valve openings, have reached the conclusion that it requires no more air to operate the four 12-inch transfer pipes of the Parral tanks than the one 16-inch transfer pipe of the Pachuca tank.

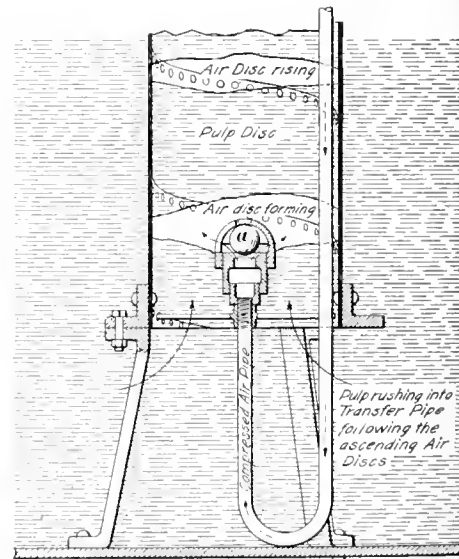

FIG. 7. OPERATION OF BALL VALVE

The comparative dimensions of the Parral tanks, as installed at the mill of the Veta Colorado M. & S. Co. and of the standard Pachuca tanks, with the individual equipment of each, may be seen in Table 1.

It may be repeated in this connection that 15 feet is the largest diameter that can be given to the Pachuca tank, while the diameter of the Parral tank may be made as great and the height as low as desirable.

An unexpected result became manifested in plotting the time extraction curves shown in Fig. 6, from the assay records of the samples taken during the treatment operations, from the Parral and Pachuca tanks when operating on the individual-charge method. In the figure the curves show parallel results obtained from the two tanks treating similar pulp under three different conditions.

采 采

Ore Mining Notes

Loretto Iron Mine, Michigan—Among the numerous places of interest visited by the members of the Lake Superior Mining Institute during their recent annual meeting was the Loretto iron mine. This mine is at Loretto in the eastern part of Dickinson County on the Sturgeon River, a tributary of the Menominee River. As the Sturgeon River formerly passed over the ore body the mine was worked by the room-and-pillar system to a depth of 800 feet. In 1908 the course of the river was diverted to the west of the ore body by excavating a new river channel, a part of which is shown in Fig. 1. Since that time mining has consisted in working out by the top-slicing system the pillars that were left.

Leadville Sugar Loaf District—Development at depth in the Sugar Loaf section of the Leadville, Colo., district indicates the coming transformation of the region into a copper camp. Placer mining for gold was the first activity in Leadville. Then followed the discovery of immense silver-bearing lead carbonate deposits of blanket formations. Later some of the mines became producers of high-grade gold ore. In recent years the production of manganese and zinc sulphide ores has been an important industry, and only last year large deposits of zinc carbonates that had previously escaped detection were found and have added largely to the output of the district. Within the last few years also, exploration has disclosed large ore shoots in fissure veins that extend through the overlying limestone and quartzite down into the granite. Two years ago, J. D. Irving, then with the United States Geological Survey, was quoted as saying: "The Sugar Loaf section will be a second Butte when it has attained the depth. The formation is exactly the same and if a Butte man was put into one of the Sugar Loaf properties without letting him know where he was, he would say he was in Butte." Ore running from 3 to 8 per cent. in copper is now taken from Sugar Loaf mines, and mining men here believe that in a few years Leadville will be a great copper camp, the first in Colorado.

Spokane Interstate Fair.—Attractive mineral exhibits from various parts of the Inland Empire were shown. The following awards were made in competitions: Best display of mine products, maps and notes, the East Pacific mine, Winston, Mont. Best district display, Covada Commercial Club, Covada, Wash. Finest ore display, Princess Republic mine, Republic, Wash. Finest display of tungsten ores and products, the Tungsten

Consolidated Co., Loon Lake, Wash. Best cabinet exhibit, Oriole mine, Metaline, Wash. Finest coal exhibit, Boundary Mining and Exploration Co., beating the Crows Nest Co., winner of the silver trophy cup in 1910. Best petrographical exhibit, University of Idaho, Moscow. Finest assaying exhibit, State College of Washington, Pullman. Exhibit of paleontology and mineralogy, Spokane College. Ore display of the North Fork, Cour d'Alene, honorable mention. A. W.

The Bureau of Mines in Colorado.—Plans for experiment work in mining and metallurgy are taking more definite shape. To provide for undertaking investigations that would reduce the costs of metal production, and thus open to profitable mining large ore deposits that cannot now be worked, was one of the purposes for which the United States Bureau of Mines was established, and the last appropriation made for the support of the Bureau gives it \$40,000 that can be used for this purpose. When Dr. Joseph A. Holmes was in Denver, on his way to Alaska, a conference of mining men was called to discuss with him the various plans for beginning the investigations in Colorado. Representatives of the San Juan district, where there are exceptionally large deposits of mixed sulphide ores, are urging the establishment of a metallurgical experiment station at Silverton. Others believe that the site should be more central, at Denver or Pueblo, for example; and still others think that advantage should be taken of the equipment available at the mining schools. No decision was reached but the adoption of some one of the plans appears probable. The Colorado School of Mines at Golden is now building a large testing plant in which ore can be handled on a commercial scale, and it has been suggested that cooperation, between this school and the Bureau of Mines would be desirable.

California Natural Gas Law.—All persons, firms, corporations, and associations in California are prohibited from willfully permitting any natural gas wastefully to escape into the atmosphere. This act is now in effect and as a misdemeanor a violation of it is subject to a penalty of \$1,000 fine, a year in the county jail, or both fine and imprisonment. The necessity for a measure of this kind arose from the fact that at different places in the state where wells have been drilled for oil and other purposes, only gas has been met with. Where it has been possible to utilize this gas for domestic or other purposes, it has been done, but there are many instances where the wells have been abandoned and countless millions of cubic feet of gas have been allowed to go to waste in the atmosphere and no attempts were made to cap the wells. Some of these wells have been flowing for years. Demonstrations that gasoline can be profitably extracted from natural gas have been made in Ohio, West Virginia, and Pennsylvania, where a number of plants have been installed. It is reported that a large plant is soon to be established in Kern County, on the Honolulu gas well, where it is expected to handle 4,000,000 cubic feet of gas daily, which is expected to yield 8,000 gallons of gasoline per day. In some instances it has been found difficult and almost impossible to control the flow of gas in wells. Owners have made every attempt to do so; but, in numerous instances where oil was sought for and only gas encountered, the wells have been abandoned without any attempt to check them. Hence, with a knowledge of these facts, State Mineralogist Aubury brought the matter to the attention of the Conservation Commission where the above bill was prepared and presented to the legislature.

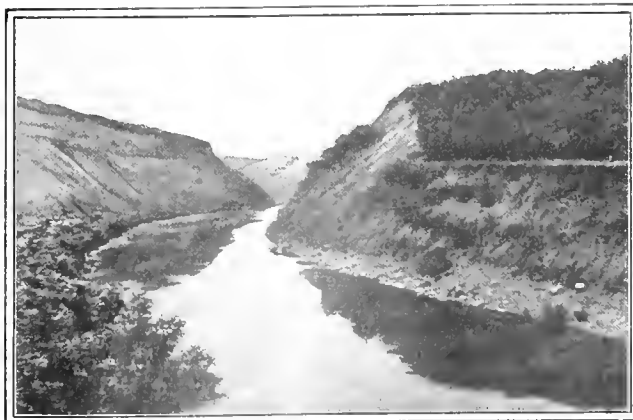

FIG. 1. NEW RIVER CHANNEL, STURGEON RIVER

Amendments to Mineral Laws.—In an address at the 25th anniversary of the Michigan School of Mines, held at Ann Arbor, George Otis Smith, director of the United States Geological Survey, talked on "The Mining Industry and the Public Lands," and "The Necessary Amendments to the Mineral Laws." It is regretted that the entire speech cannot be reprinted. Abstracts from the speech follow, and the suggestion is made that the western readers of MINES AND MINERALS send to Washington, D. C., for the entire speech.

Legislation for United States Oil Lands.—The need for remedial oil legislation is somewhat less acute than it was two years ago, by reason of the passage of the act approved March 2, 1911, the effect of which is to validate a class of oil claims which, while clouded by the construction which the Department of the Interior was forced to place upon the misfit placer law, under which title to oil lands must now be made, were bona fide, in that the inception of their development antedated the oil land withdrawals. This enactment was in accord with the spirit of the withdrawal act, which provides for the protection of equities already established. The need for a better law is, however, imperative and the legislative action demanded by the situation should not be limited to an attempt to revamp the general placer law.—GEO. OTIS SMITH.

Repeal of the Apex Law.—The same knowledge of natural conditions that leads to the suggestion of a repeal of the law of the apex forces the further suggestion that discovery of ore in place cannot be made universally a prerequisite to the location of a mining claim. Geologic study of ore deposits has furnished examples in a number of regions where the present law cannot be complied with, although rich deposits exist underground and their extent can be more definitely surmised than in most cases where ore is discovered at the surface. To meet such actual conditions the law should provide for the acquisition of metalliferous mineral land classified as such upon the basis of adequate geologic evidence, whether actual outcrops are present or not.—GEO. OTIS SMITH.

Square Mine Claims Advocated.—The unit of disposition should be the claim, preferably square, limited on its four sides by vertical planes, and of a size sufficient to allow the miner occupying two contiguous claims to follow the vein or lode to considerable depth, even if its dip is only 45 degrees. Such definition of a mining claim is found practicable in both Mexico and British Columbia, and in the latter country the change from the apex law was effected without trouble or confusion. GEO. OTIS SMITH.

Results From Grubstake.—The richest sample of ore received from the prospectors sent out by the grubstake committee of the Denver Chamber of Commerce assayed \$460 to the ton. It was found in the La Plata district, about 2 miles from Durango, by O. N. Kee. "There have been stampedes to new mining districts for strikes of less promise than this," said Ernest LeNeve Foster, a member of the committee.

Quebec Placer Mine.—Owing to the name "Dominion" being associated with mining schemes of more or less "wild-catty" nature in various parts of Canada, the directors of the Dominion Gold Fields, Limited, in Beauce, Quebec, have changed the name to "La Compagnie des Champs-d'Or Rigand-Vaudreuil." This company was the one mentioned in the Report of Mining Operations in the Province of Quebec, 1910, issued by the Quebec Department of Mines.

Tungsten in Colorado.—Because of the depressed condition of the steel industry, and the contracted market for tungsten, there has been less activity than usual the past year in the tungsten fields of Boulder County, but the gold output of the country is increasing. The tonnage handled by the Chamberlain-Dillingham sampler at Boulder is 23 per cent. heavier, while there has been a gain of 80 per cent. in the total value of the ore sampled. To some extent the increased production is due to the distribution of central station power throughout the country.—C. S. I.

Platinum in Colorado.—Platinum assaying \$500 a ton is reported in what is said to be a sandstone deposit that was recently discovered in the Naturita Valley, near Norwood, in San Miguel County. In appearance the ore resembles the vanadium ore found in the same region. The platinum discovery was made on claims located a month or two ago. Assays of the first samples gave gold, one \$80 and one \$64 a ton. The latest assays give \$500 in platinum, \$84 in gold, and a trace of silver.—C. S. I.

Clear Creek County Gains.—Gains of 15 to 20 per cent. in the quantity of ore handled each month this past year are reported by the management of the Chamberlain & Dillingham sampler at Idaho Springs. The tonnage for July was 2,200 compared with 1,720 for the same month a year ago. The Hudson mill, at Idaho Springs, is to be converted into a cyanide plant, and the manager, A. B. Roller, is confident that he will be able to treat at a profit ore running as low as \$2.75 a ton.

Alaskan Gold.—He—The last boat from Alaska brought \$1,800,000 in gold. She—Was any of it yours? Nome.

Vanadium Reaction Plant.—According to advices the only local plant in Colorado that treats the vanadium ores of Paradox Valley is the Primos Chemical Co., of Newmire, Colo. The product obtained is vanadic acid and no attempt is made to recover the uranium in the ore.

Cripple Creek Independence Mine.—The gross production of Stratton's Independence, Limited, computed to January 1, 1912, has been \$22,200,000. John Hays Hammond, in a report made in October, 1900, said that the production up to that time had been \$8,250,000, and placed an estimated value of \$2,290,000 on the ore then in reserve. It is now believed that the mine has at least another 10 years of profitable production.—C. B. I.

Cripple Creek Drainage.—Work has begun on an extension of the Roosevelt tunnel, which provides deep drainage for the mines of the Cripple Creek district. In the 12 months since the completion of the tunnel the water level has been lowered 65 feet. The present flow is about 6,000 gallons per minute, and pumping has been stopped in the Portland, Elkton, and other large mines. Before drainage provided by the tunnel became effective, the pumping expense in the Elkton alone amounted to \$375 a day. The extension on which work has just been started will be 2,000 feet in length. In about 1,000 feet it is expected to cut the Gold Dollar water courses, thus increasing the flow from the tunnel and the rate at which the water level is lowered. A fund for extending the tunnel has been raised, the principal contributors being the Portland, Elkton, Vindicator, Strong, Gold Dollar, Cresson, Blue Bird, Stratton's Cripple Creek, and Granite companies and the railroads of the district. The El Paso will soon start drifting on the C. K. & H. vein from the point where it was intersected by the Fuller cross-cut from the Roosevelt tunnel. The flow from this vein, which is now 1,200 gallons a minute, will increase as the drifting proceeds.—C. S. B.

Hecla Mining Co., Idaho.—By the payment of its ninety-ninth dividend this company has paid almost 10 times the par value of the capital stock.—A. W.

Kendall Mine, Mont.—This company, incorporated for \$500,000, has paid \$2,000,000 dividends to date.

Discovery of Platinum.—Discovery of platinum near Slocan Junction, B. C., has resulted in a rush of locators to the Kootenai River. The assays from samples range in value from \$72 to \$176 a ton. The extent to which claims are being located will be understood when it is known that one prospector staked a claim, which included the city power plant at Nelson. Ranchers in the district are defending their holdings against invaders.—A. W.

Idaho Placer Rediscovered.—James Daniels, deputy collector for the United States Custom House in Spokane, has received advices from Ah Yen, a local Chinese trader, of the rediscovery of rich placer ground in the Blackfoot district, in

Idaho, 93 miles southeast of Spokane, where fortunes were washed from the sand and gravel more than 30 years ago. Yen asserts that the original find was made by two Chinese miners who were killed and robbed by a white claim jumper following a clean-up in 1882. The placers are 4 miles from a flowing stream, Yen says, adding that it would require 15 miles of flumes to convey water to the deposits. Ah Yen said he would not locate the claims, as he feared meeting the fate of his countrymen.—A. W.

Independence Placer Claims Co. is organizing a crew to work its properties on Moose and Independence creeks, below Moose City, Idaho, which was a prominent mining center 47 years ago. Recent discoveries of gold are the causes leading to this renewed activity in one of the oldest placer camps in the Coeur d'Alene district.—A. W.

Liberty Bell Mine.—A damage suit for \$500,000, brought by the Morehead M. & M. Co. against the Liberty Bell G. M. Co., is the occasion for convening the District Court in special session at Telluride. Trespass is alleged and admitted, but the defendant company asserts that the trespass was inadvertent and that no ore of any value was removed from the property of the plaintiff.

Hibernia Mine Accident.—On October 19 the miners in one of the Hibernia iron mines, Morris County, N. J., belonging to the Wharton Steel Co., broke into an adjacent abandoned mine containing water. The rush of water was so great 12 men were drowned. Pumping is continued night and day, but it is not thought that the bodies will be recovered before the 1st of December.

United States Smelting, Refining, and Mining Co., which operates custom plants in Mexico, California, Utah, and other states, has taken out a license in Washington and appointed A. C. Barke, formerly connected with the smelter at Northport, Wash., as its representative. The company also has agents in the Coeur d'Alene and Nelson districts. Mr. Barke confirms the report that the company has acquired the Gold Road mine in Arizona for \$1,250,000 and the Rainbow mine in the Mormon Basin, Oregon, for \$700,000. The company has no mines in the Coeur d'Alenes, but handles the bulk of the ore produced in that district.—A. W.

Nevada Hills New Mill.—The Nevada Hills mill has now been tested and is meeting the difficulties incident to beginnings. The plant is still unfinished, and some of the ore is sent to Hazen for treatment. As reduced in Fairview, it averages about \$2.50 a pound. The ore is like the Tonopah ores, much of it high grade, containing manganese and difficult of treatment. The handling is now being adjusted to the product. No high grade is risked in these first runs, but the ore, culled, as it is with a view to economical experiment, averages \$20 per ton. From the very first, economy was aimed at in the running of the plant and ignored in its building. No expense was spared. The mill was built by the company which was to operate it. Every board and every screw was inspected; and, when \$1 was not enough to patch a weak place, \$5 were expended if necessary. In this plant the treatment of the ore is continuous. A given particle never stops from the time it enters the stamps until it leaves as tailing at the foot of the mill. There are nine Pachuca tanks, and the slime is passing continuously until it has gone through the series. This saves the transfer and waiting of the ordinary process, and the constant danger of choking. Three large tanks arranged tandem and filled with cyanide solution much reduce the work of the filters and minimize the values left in the tailing. The mill site was selected close to the mine shaft. Large quantities of the rock are soft and can be broken down with a pick. It is easy for even a layman to see how expense will be minimized with the rock simply knocked from the ledge and hoisted directly to the mill hopper. The mill was designed by Fleming, the constructor of the Goldfield Consolidated mill. He was justified in saying, as he did: "This is the most up-to-date and the finest mill in the state of

Nevada." Of late there has been considerable speculation over the future of a property adjoining Nevada Hills, and having substantially the same management. This is Golden Boulder, of which George Wingfield is president. It is just over the hill, its tunnel with a shaft about 200 yards from the Eagle shaft of the Nevada Hills. The old Nevada Hills shaft, the Eagle shaft, and the Golden Boulder workings being nearly in a straight line, are supposed to be on one ledge. High-grade ore is in the collar of Golden Boulder's shaft. Milling ore is here and at the 50-foot level.—H. F. A.

Western Illinois Zinc Furnaces.—Cheap coal continues to be the drawing feature of zinc smelteries in western Illinois. The Lanyon Zinc Co., of Kansas, is planning to build a zinc smelter at Allen's Park, a few miles east of East St. Louis, Ill. This is the third zinc plant that has been started in this section within the last year. The largest of these plants is situated near Hillsboro, which, when completed, will have cost \$1,500,000. There is a smaller plant being built in Hillsboro and both are to utilize the sulphur fumes from the roasters to manufacture sulphuric acid. The zinc smeltery at Sandoval is being remodeled to a zinc-lead refinery.—J. I. B.

乘 乘

Catalogs Received

ALLIS-CHALMERS Co., Milwaukee, Wis., Bulletin No. 1074, Direct-Current Motors and Generators, types H and HI, 12 pages; Bulletin No. 1075, Belted Alternating Current Generators, 16 pages; Bulletin No. 1077, Lighting Transformers, 12 pages; Bulletin No. 1078, Alternating Current Generators, 16 pages; Bulletin No. 1082, Engine-Driven Direct-Current Generators, types I and IW, 16 pages; Bulletin No. 1083, Direct Current Motors and Generators, type K, 20 pages; Bulletin No. 1211, Feeders for Roller Mills, 4 pages; Bulletin No. 1519, Barometric Condensers, type AN, 12 pages; Bulletin No. 1721, Trimmers, Slashers, and Cut-Off Saws, 20 pages.

THE C. O. BARTLETT & SNOW Co., Cleveland, Ohio, Catalog No. 32, Triumph Drop Forged Chains, 32 pages.

CARNEGIE STEEL Co., Pittsburg, Pa., Heat-Treated Axles, Shafts, and Similar Parts, 38 pages.

GENERAL ELECTRIC Co., Schenectady, N. Y., Bulletin No. 4857, Switchboard and High Tension Relays for Alternating and Direct Current, 32 pages; Bulletin No. 4876, Small Plant Direct-Current Switchboards 76 inches high, 12 pages; Bulletin No. 4878, Cloth Pinions, 6 pages; Bulletin No. 4879, Direct-Current Instruments, types D-7 and D-8, 12 pages; Bulletin No. 4882, Enclosed Flame Arc Lamps, type K, 4 pages; Bulletin No. 4883, Curtis Steam Turbine Generators, 48 pages; Bulletin No. 4884, The Lighting of Iron and Steel Works, 40 pages; Ignition Cables, 8 pages; A Few G. E. Switchboards, 4 pages.

INGERSOLL-RAND Co., 11 Broadway, New York, N. Y., Class PB Duplex Power Driven Air Compressors, 24 pages; Class NE-1 Power Driven Single Stage Straight Line Air Compressors, 12 pages; Imperial Type X Duplex Steam Driven Compressors, 20 pages.

JEFFREY MFG. Co., Columbus, Ohio, Catalog No. 50, Jeffrey Power Transmission Machinery, 142 pages.

NATIONAL ELECTRIC LAMP ASSOCIATION, 4411 Hough Ave., Cleveland, Ohio, Bulletin No. 8C, Miniature Carbon Lamps, 22 pages; Bulletin No. 12A, The Electric Lighting of Automobiles, 28 pages.

CHICAGO PNEUMATIC TOOL Co., Chicago, Ill., Catalog No. 36, Rock Drills, 88 pages.

ROBERTS & SCHAEFER Co., Chicago, Ill., Bulletin No. 23, Holmen Locomotive Coaling Stations, 32 pages.

ROBINS CONVEYING BELT Co., New York, N. Y., Bulletin No. 46, the first of a new series to be issued monthly, 48 pages.

WHEELER CONDENSER AND ENGINEERING Co., Carteret, N. J., Bulletin No. 107, High Vacuum Jet Condensers, 20 pages.

Topographical and Geological Mapping

Methods and Instruments Employed by the Parties Making the Survey in the Field

By A. J. Hoskins, E. M.*

The layman who reads a geological survey report and peruses the accompanying maps is usually impressed with a degree of inquiry as to how these documents were prepared in the field. Even a person who has studied the theories of geology and surveying (unless he has had the field experience) is often at a loss to explain to his own satisfaction just how the work and the observations are conducted on the ground.

There are many facts, of varying sorts, to be determined in the field for incorporation into text matter and maps; and the successful man at this profession requires knowledge that can be derived only through actual field acquaintance with the problems involved.

Geography, topography, geology, and the improvements or alterations accomplished by men constitute the usual items to be considered in the preparation of any map that will prove most useful to the average citizen. And, since it is the intention of the federal and state governments to place such publications in the hands of the practical, every-day citizen rather than of the scientist, the reports and the maps that go with them must be prepared accordingly. This statement must not be construed to mean that such surveys are lacking in scientific accuracy, for such is not the fact. But, while containing the essence of such correctness these documents must be so prepared as to convey such scientific truth to the average reader in popular language.

There are usually two or more ways of accomplishing any desired end, as is testified by the old saw about "skinning a cat." Geological surveying is no exception to this great statement. Hence, it must not be supposed that all geologists and topographers employ precisely similar field methods. The published report usually gives no inkling as to the procedure of the field work that secured the notes therefor.

Dissimilar natural conditions or work requiring different degrees of detail in results will call for unlike methods. Thus, a survey in a comparatively flat region with dense vegetation and very few exposures of rocks in natural place calls for efforts different from those employed in the survey of a rugged area above timber line. One can carry out this line of reasoning to any extent and find a multiplicity of natural conditions that might probably be approached by the geological surveyor in varying ways. But, even assuming certain conditions to prevail in any given instance, it is quite probable that two different surveyors would exercise their personal and differing ideas in accomplishing the field work preparatory to writing a report and drawing a map. Therefore a complete description of all the geological survey methods used even in the United States alone would be voluminous and it would undoubtedly prove very uninteresting to most magazine readers. Accordingly, this article will confine itself to the methods of but one survey party, and thereof the writer can speak with full knowledge. The following is submitted as a description of the work performed by one corps of the Colorado State Geological Survey. The methods have produced good results for several seasons. Some experienced field geologists will probably prefer to follow different schemes, but, on the whole, the procedures described herein could be readily adapted to surveys of like character in any mountainous regions. It is not, however, the object of this paper to instruct the professional geological surveyor, but to give the layman some notions about the labors involved in the preparation of geological surveys.

The Colorado Geological Survey is directed by the State Geologist, Prof. R. D. George, of Boulder. As Director of the

Survey, he organizes parties that spend the three summer months on field work in various portions of the state. The selection of areas is based upon the desires of the state's citizens; and such localities are surveyed as appear to present to the prospectors and miners the greatest difficulties in the interpretation of the formations. Generally, there are several parties out in the field each summer. The results of such field work are worked up into publishable form during the following winter months, so that the reports are issued the following year.

The number of men to a party is variable and depends upon the extent of the district covered as well as upon the extent of detailed work required. Parties will therefore contain from 2 to 18 men.

The chief object of the survey is to promote the mining industry of the state, and the reports thus far issued have been almost entirely on mining districts. In Colorado, the metal-mining districts are in mountainous country, in which the desirable season for careful study of the formation is during the few months of summer when the ground is bare of snow. Often a survey will cover patches of snow that never leave, and the geologist must make due allowances. The reports of the survey are for free distribution to parties who are sufficiently interested to apply to Director George for copies.

Since the districts surveyed are usually of considerable extent and remote from most modern conveniences, the party under description has provided itself with a very complete tenting outfit. One large mess tent serves not only as an eating place but it really constitutes the office and headquarters while the party is in the field. Adjoining this tent is erected the cook tent and pantry. A separate tent is used for storing instruments and the miscellaneous articles needed on such trips. Since there are horses required in the work, provision is made for housing grain and saddles, the animals themselves being picketed in the open. The horses have proven indispensable in reaching areas that are distant, or at considerably different elevations from camp.

The number of sleeping tents depends upon the size of the party. The men in charge occupy tents individually, but the younger members of the party to be mentioned later are assigned two to a tent. The cook has a tent by himself.

The instrument outfit is not required to be extensive. It includes two to four good, accurately adjusted transits, one or two levels, short and long steel tapes, level, and stadia rods reading to hundredths of a foot, range poles, a supply of white and waterproof red bunting for making flags, drafting boards, parallel rulers, protractors, drawing pens and pencils, various colors of inks and pencils, eggshell vellum papers. Each man is provided with a pocket magnifying glass, a field note book, and a small plane table. Each of these individual plane tables is simply a 12"×16" pine board 1 inch thick, with a nut recessed into its under side whereby it may be mounted upon an ordinary light camera tripod. An oil cloth tacked along one edge serves as a flap cover for the map that is thumbtacked on the upper surface of the board. One such small plane table will contain sufficient mapping area for many days of work in the field.

Each member of the party is provided also with an Atwood clinometer constructed especially according to specifications prepared by Dr. H. B. Patton, of the Colorado School of Mines, and who is the chief of this party under description. This little instrument, 3 in. × 6 in. × ½ in., fits the pocket and serves splendidly as a clinometer, compass, alidade, and protractor.

Topography Methods.—The first task of the party, after establishing camp, is to select and run a base line. This line must be so chosen that from the ends of it many of the prominent features of the landscape are visible. The longer the line can be, the greater satisfaction it will give. Whenever possible, the line is laid off perfectly straight; but, sometimes, to gain sufficient length, it must contain angles. In rough mountainous country, the selection of this line may amount to quite a task.

* 308 Commonwealth Building, Denver, Colo.

It is not always possible to pick out a base line whose ends will be visible from one another, but this feature of mutual visibility is a very desirable one. Since known elevations or bench marks are generally along the valley or gulch portions of a rough district, the carrying of elevations must proceed from such low ground. Hence, this party has followed a practice of establishing its base lines along the water courses, or in as open low country as possible. Sometimes, when surveying a very large area, two base lines are run quite independently, in different parts of the district, and these are subsequently connected by triangulation.

The running of the base line is done repeatedly, by different men, using different instruments and tapes, and making use of independent intermediate stations. The horizontal distances are calculated from the slope measurements, using the cosines of the observed vertical angles. All measurements are made to hundredths of a foot. The steel tapes used are graduated every foot, and each member of a surveying party carries a short 1-foot scale for use in interpolating the fractional distances. These tapes have been standardized by comparison with accurate tapes. In making a measurement in the field, it has not been deemed necessary to make allowances for changes in temperatures; but the facts that the primary lines are run several times, by different parties, using different tapes and usually upon different days and under varying conditions of weather and temperature, and that the averages of such measurements are taken as the final ones, make it reasonably fair to assume that the distances thus determined are within any limits of error that could possibly have any appreciable effect in results. To avoid complex calculations for tension in tape and foreshortening due to the catenary, the writer has had the transitman follow the practice of giving the long tape, at times of measurement, a swaying motion in a vertical plane, the fore-chainman meanwhile holding the zero mark on the tape constantly on the forward station. In this way, the transitman will cause the tape at his position to lengthen and shorten with each sway, and by repeatedly moving his thumb and finger with each observed shortest distance, he will within a few moments have gripped the tape at the exact point that indicates the true distance between the axis of his instrument and the forward station, for this distance will be along a straight line. This scheme puts no great stress in the tape, and, in fact, at the moment of shortest length, the stress is the least possible and is just sufficient to assure that all small kinks in the tape are pulled out taut. Hence there are no allowances required for either curvature or tension.

Having established the two ends of a base line by the erection of permanent stations, precise leveling is next done to determine the difference in elevation between the end, or primary, stations. This work, also, is gone over repeatedly by different parties, and the average of the several results taken as standard. Meanwhile, very careful leveling is being carried on to connect either end of the base line with some known, reliable bench mark. Should there be a branch of one of the main railroad systems within a reasonable distance, the office of the chief engineer of such railroad system will generally be able to furnish data that are amply accurate; for the leveling of railroad lines is carried over so many devious routes, with so many opportunities for rechecking, not only by surveys over a company's various branches but also by turning into surveys of other railroad companies, that elevations along the rights of way are pretty accurate. If some railroad line is not accessible, it is possible that there has been an elevation established somewhere not far away, by some public or private surveying party. As a last resort and to be used only as a temporary expedient, for subsequent correction, elevations may be carried into the district from an outside bench mark, by repeated readings of high-grade aneroid barometers.

The base-line primary stations are designated by letters, as A and B. All other stations are given numbers. From

both ends of the line—and sometimes, also, from an intermediate station along the line—observations are made to stations previously set on prominences that are visible from the primary stations, and very careful readings are taken on the vertical and horizontal angles. True bearings are determined from repeated observations on the sun. All angles are taken by reading the instrument erect and inverted. The horizontal angles are repeated by doubling and quadrupling. Calculations from these notes are made in camp by the usual trigonometrical methods. To show the routine followed by this field party in

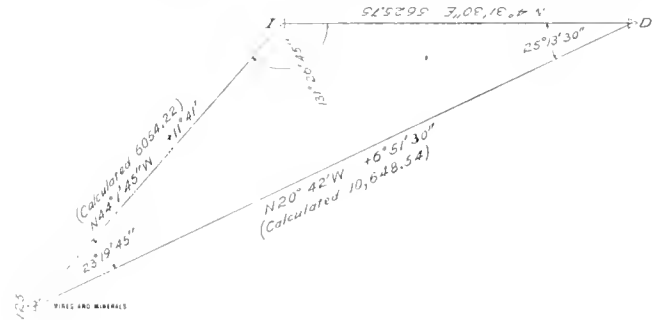

FIG. 1

reducing its field notes, an example, taken at random, is given here. The line constituting the base of the triangle is one of the primary base lines, designated as *D-I*. Its length has been determined as 5,625.75 feet, and its course is $N 4^{\circ} 31' 30'' E$. With a height of instrument of 3.51 feet at *D*, the averages of the readings gave for the line *D-125*, bearing $N 20^{\circ} 42' W$ on a vertical angle of $+6^{\circ} 51' 30''$. Setting up at *I*, the height of instrument was 2.67 feet, the bearing to *125* was $N 44^{\circ} 1' 45'' W$, and the vertical angle was $+11^{\circ} 41'$. A sketch is first drawn on the calculation sheet, freehand, as in Fig. 1, herewith, and the computations are as follows:

Log. 5625.75	13.7501804		
Log. sin. $23^{\circ} 19' 45''$	-9.5977094		
	11524710		4.1524710
Log. sin. $25^{\circ} 13' 30''$	-9.6295870	Log. sin. $31^{\circ} 26' 45''$	9.8718190
Log. 6054.22	3.7820580	Log. 10,648.54	4.0272900
Log. tan. $11^{\circ} 41'$	-9.3155226	Log. tan. $6^{\circ} 51' 30''$	9.0801771
	3.0975806		3.1074671
	1251.93		1280.76
H I	2.67	H. I	3.51
Elev. I.	10170.54	Elev. D	10410.49
	11725.14		11724.76
11725.14			
11724.76			
2)23449.90			
11724.95 = elevation of 125			

On the published map this elevation would be given as 11,725 feet.

The triangulation work is extended indefinitely, precisely similar calculations being made for all the secondary work.

All wagon roads, fences, streams, and trails are run by transit and stadia rod, for they are subsequently checked into place by measurements here and there from the triangulated points, which are numerous. In the survey of an area covering about 50 square miles, we established over 200 stations accurately with their elevations.

All platting is done on a scale of 1,500 feet to the inch. Having constructed a plat of the triangulation and the stadia work, this constitutes the skeleton upon which is built the topographic and geologic maps. For the further work, the entire party is divided up into squads of two men each, and

each territory is referred to a specific portion of the district. This territory is spoken as a "territory." Within this restricted area the squad in charge "works in" all the topographical and geological details. Contours are drawn every 100 feet. For this work the pocket level proves its constant usefulness. Upon surfaces of nearly uniform slope, it is possible for surveyors to determine and sketch in the contours without actually leveling from top to bottom (or vice versa), for the intervals that will show between the contour lines on the map are nothing more nor less than 100 times the natural cotangent of the angle of slope that is observed with the clinometer. Therefore, as many of the contours can be traced on the map as are required to fill the differences of elevation between the bottom and top of the slope, and this without the task of climbing. Usually the ground must be gone over completely twice—once for topography and once for geology. Naturally, in the course of the contouring, much attention will be devoted to the formations, and the notions thus obtained will prove useful in arriving at the details subsequently. There are frequently portions of territories that are of such difficult access as to make it desirable to traverse them but once on foot, and in such areas the duties of contouring and geologizing are done simultaneously.

Although two men perform the work of detailing the geology and topography in their particular territory, it is obvious that they are obliged to consult with and work in conjunction with the squads operating the adjoining territories in order to make their results harmonize at the boundaries which do not appear in the resulting map. For the field mapping, the small plane tables already mentioned are used. In contouring, when it is often necessary to use the pocket instrument as an alidade, the boards are carried upon the light tripods; but if the topography has been sketched in, the working in of the geological details is done by merely carrying and using the board as a support for the map.

After the platting of the skeleton map previously mentioned, the men of the several squads trace from it the features that belong in their respective territories, and this is the basis of their subsequent field work. The whole plat is ruled into 1-inch squares, as shown in Fig. 2, and the traced portions that are carried into the field by the squads show these same subdivisions, which are extremely useful in the designation of localities from which rock specimens may be obtained during the progress of the field work. These quadrille rulings also very materially assist the surveyor in his scaling of distances while in the field. If it seems well to bring to camp specimens of a rock or mineral for determinations that cannot be made in the field, such specimens are labeled with the decimal abbreviation that is apparent from this scheme. The largest unit represents 4,500 square feet and bears a number, as in this instance 59. This unit comprises nine squares of 1 inch on a side, each inch square thus covering a field area of 1,500 by 1,500 feet. Further subdivision brings the size of a square to $\frac{1}{3}$ of an inch, representing a distance of 500 feet. This is as far as the subdivision is carried, but when occasion arises for minute location, the small squares may be repeatedly subdivided. Thus a specimen taken at the cross would be labeled 59 1953.

The time required in doing such field work naturally depends upon many conditions of nature as well as upon the experience and number of men in a party. Probably one-half of the entire time is occupied upon the triangulation and topography, especially in the rough country of Colorado's mining regions. With a party of 10 to 12 men, in 8 weeks an area of about 28 square miles in very rough country was surveyed this past summer. It must be borne in mind that this field work will be followed by a great amount of office work before reports and maps can be published. This work is now in progress.

The cost of this sort of work is extremely low, when compared with many other kinds of professional work of no higher grade. The state of Colorado has been fortunate in securing the services of experienced geologists who occupy collegiate professorships and who are very glad to spend their summer vacations in their chosen lines under conditions that are of distinct benefit to the physical man. They are willing, therefore, to perform this work at prices far lower than such expert service is worth.

Dr. H. B. Patton, Professor of Geology at the Colorado

School of Mines, is the real head of the party, whose methods are described in this article. Some few years ago he conceived and inaugurated a scheme whereby the state of Colorado was greatly benefited and whereby also the students of the school were granted unusual privileges. These are required for graduation from this institution. These may be selected along geological lines with the permission of the faculty. At the close of the junior year, therefore, a selection is made from those applicants who have expressed a wish to take geological theses the coming year. This selection is based upon the grades attained by the applicants in their geology, mineralogy, and surveying courses. These successful students are required to pay all of their traveling and camping expenses, and in return they benefit by the splendid

4	48	6	4	49	6	4	50
7	8	9	7	8	9	7	8
1	2	3	1	2	3	1	2
4	58	6	4	59	6	4	60
7	8	9	7	8	9	7	8
1	2	3	1	2	3	1	2
4	68	6	4	69	6	4	70
7	8	9	7	8	9	7	8

FIG. 2

experience and the acquisition of material for theses. Low railroad rates are obtained for such a party, while provisions are purchased in wholesale lots; and in this way the actual cash cost to a man is not great. Two or three experienced men will direct all the field and office operations. The state is charged only for the small salaries paid the men in charge and for their legitimate expenses, which are very small indeed. There was a considerable outlay the first season for equipment, such as tents, cooking and eating utensils, etc., and there is a small annual expense for repairs and upkeep, but this is nominal. Horses are usually purchased at the beginning of the season and sold at the close of the season. Careful accounts are kept by Doctor Patton of all expenditures. At the end, these are pro rated among the individuals of the party. In this way, the Geological Survey finds an economy through the employment of these undergraduates, for the per capita expense will naturally be less as the size of the party increases. The actual expenses per man will run about 80 cents per day and this must be conceded as extremely reasonable. The total cost of a summer's survey by this one party, chargeable to the Survey's account, is, in round numbers, about \$1,000, or \$38.46 per square mile, or 6 cents per acre.

Treatment of Broken Hill Ores

The Huntington-Heberlein, Carmichael-Bradford, Savelsberg, and Other Sintering Processes

By W. Poole, B. E.*

This abstract is from a paper "On Treatment of Broken Hill Ores," read by Director Poole before the Sydney University Engineering Society. It treats of the Huntington-Heberlein, Carmichael-Bradford, Savelsberg, and other pot-sintering processes.

Originally most of the Broken Hill companies smelted their ore at Broken Hill, but one by one, especially since the treatment of sulphide ore became necessary, the various companies dismantled their old and erected new plants on the seaboard, e. g., the British company, at Port Pirie; the Junction company, at Dry Creek; Block 14, at Port Adelaide; and the B. H. P. Company, at Port Pirie, all in South Australia; and the Sulphide Corporation (Central mine), at Cockle Creek, near Newcastle, New South Wales. Since then, one by one, these reduction works, with the exception of the B. H. P. Company's Port Pirie works, Fig. 3, and the Cockle Creek works, have ceased operation. A customs works, erected at Dapto, New South Wales, largely to treat Broken Hill concentrates, has also closed down. The B. H. P. Company treats the products of several other Broken Hill mines besides its own, but the production of the remaining companies not possessing smelters is sent to Europe (mostly Germany) for treatment.

The Port Pirie metallurgical works is probably the largest of its kind in the world. At these works a complete series of processes is in operation, resulting in the production of desilverized and refined soft lead, antimonial lead, as well as silver bullion and gold bullion of great fineness. The following descriptions will principally be those in operation at Port Pirie, both because they are more complete, and also because the writer has a more intimate knowledge of them, having been night superintendent and assistant metallurgist there for several years.

After exhaustive experimental trials in 1901, the Huntington-Heberlein desulphurizing and sintering process was adopted. The introduction of this epoch-making process caused a great alteration in the general practice, increased the capacity of the plant, and effected great economy in the production of lead bullion. So great was the increase in capacity that eight blast furnaces did more work than thirteen had previously been able to do.

It will be of advantage and increased interest to also consider similar and parallel processes to the Huntington-Heberlein process, and the Carmichael-Bradford process, which are applied to Broken Hill lead products. These processes are the Kapp-Kunze process, used at Zeehan, Tasmania, and Chillagoe, Queensland; and the Savelsburg process, used in Germany on leady ores; and the McMurtry-Rogers process for

copper ores and mattes used at Wallaroo, South Australia. It will be advantageous also to consider the heap-roasting of slimes at Broken Hill.

Huntington-Heberlein Process.—This process was the pioneer of the pot-desulphurizing and sintering processes. It has been used principally with lead ores and leady concentrates.

In brief, this process consists in mixing limestone and ironstone with the ore, and also in adding siliceous material if the ore or concentrates do not contain sufficient silica. The mixed material is partly desulphurized in a roasting furnace. Upon discharge, and while still red hot, it is fed into conical or bowl-shaped iron vessels of suitable construction, and a blast of air forced through the charge Fig. 2. Thermochemical action takes place, resulting in the ore being desulphurized to a low point, and at the same time the heat generated by the action has been sufficient to fuse or sinter the whole mass, which upon cooling is somewhat like coarse vesicular lava. The total desulphurization is equal to a good straight-out roasting, while the physical condition of the product is an ideal one, instead of a mass of fines which had previously been the nightmare of blast-furnace metallurgists, especially those treating lead ores. Previous to the introduction of this process, and

those directly suggested by it, it had been necessary to sinter the fines on a special hearth at the end of the roasting (as originally at Cockle Creek works), causing an appreciable loss of lead and silver by volatilization and giving a passable product; or the fines were mixed with a small proportion of lime or other binding, and briquetted in machines, under heavy pressure, or worked up on a pug mill, molded, and dried as at Port Pirie. Both the latter were expensive, costing from \$1 to \$1.25 per ton and the pug mill product was far from satisfactory.

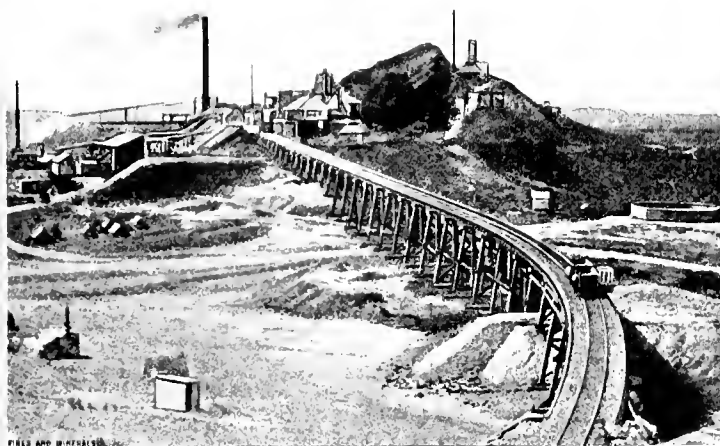

FIG. 1. PROPRIETARY MINE VIADUCT, BROKEN HILL

The Huntington-Heberlein process marks an epoch in modern lead smelting, rendering the treatment of fine lead concentrates easy, economical, and admitting of high recoveries of lead, silver, and gold. The introduction of this process has been of inestimable value to the lead industry of Australia and Tasmania and it has been installed in the Tasmanian Smelting Co.'s works, at Zeehan, Tasmania; the Sulphide Corporation works, at Cockle Creek, New South Wales; the B. H. P. Company's works, at Port Pirie, in South Australia; and at the Chillagoe Mining and Railway Co.'s reduction works, at Chillagoe, North Queensland; also at the Fremantle Smelting works.

The practice at Port Pirie is as follows: Before charging into the roasting furnaces the concentrates are mixed with amorphous limestone, ironstone, or silicious ore or sand. The limestone is put through a crushing mill and reduced to the size of coarse sand, or finer. Amorphous limestone was found, after comparative trials, to give much better roasting results than the hard crystalline limestone used as direct flux in the blast furnaces. The ironstone is a rich hematite from Iron Knob, South Australia. It is also finely crushed. Sometimes a portion of the ordinary lead concentrate is replaced by raw settled slime or by crushed raw lead matte. The mixture is made up in definite charges. The proper weight of concentrate is taken from the bins, then the requisite weights of crushed

* Director of Charters Towers School of Mines, Australia.

limestone, iron ore and siliceous ore or sand are placed into the same truck, which now holds one charge, and this is tipped with a further mixing into the feed-hoppers of the Ropp furnaces. The charge is fed continually into the furnaces by means of a revolving fluted cylinder at the bottom of the feed-hopper. The action of the rabblers is to thoroughly mix the ingredients by the time they have traveled a few feet into the furnace. These Ropp furnaces, five in number, are of very large size—150 ft. × 14 ft. There are six sets of rabblers—one set turns the material to the right, the next to the left, and each works it slightly forward. It takes about 12 to 16 hours for material to work through the furnace. When coal-fired, there were three fireboxes to each roaster, spaced along one side of the furnace. The one at the discharge side, or finishing end, is most strongly fired, and the other two successively less. These furnaces are now fired with producer gas. They had originally been erected for an ordinary non-sintering roasting. Hoppers at the discharge end were added when the Huntington-Heberlein process was installed, so as to accumulate and keep hot material for charging a converting pot. Formerly a complete charge of hot material was drawn from the furnace hopper for each pot, the blast turned on, the "cooking," or converting, proceeding until the operation was finished. Recently an

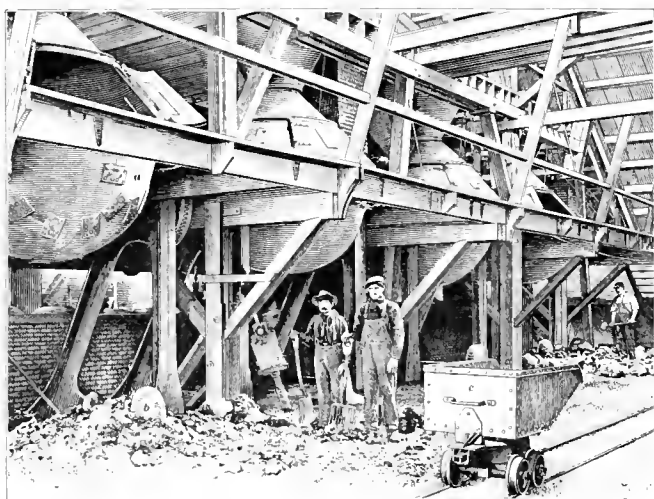

FIG. 2. DESULPHURIZING AND SINTERING FURNACES

important alteration was made, viz., the lower portion of the charge consists of hot material as formerly, but the upper and larger part consists of roasted material, which has been wetted, and is charged in a wet condition into the pots. This alteration has improved the process. It will be shown later that in the other pot-roasting processes the material is charged cold, and generally in a wet or damp condition. The action commences at the bottom of the charge and around the inlet of the compressed air, and gradually creeps up through the charge to the top. Bars are inserted from time to time to break up blow-hole tubes, which, if left unchecked, would allow the action to reach the surface by a few tubes and die out, leaving much of the charge unsintered. When a well-appointed mixture is used and properly attended to in the pot sintering, the whole of about 2 ounces pressure is turned on, so soon as the chips of the mass, except a small amount on the top, are converted into a sintered compact vesicular mass. When the action is complete the blast is shut off, the pot inverted, and the mass tipped out on the ground beneath, more or less breaking it, cooled by a jet of water, the large lumps broken and the whole of the material except the fine pieces sent to the blast furnaces. The fine pieces are put back into the pots with later charges. The action in the pots is completed in from 4 to 6 hours. The dust from the roaster, pot converter, and smelter flues is put in a part of the pot charge.

At the Cockle Creek works large quantities of auriferous pyrite concentrate are worked up in the process. Godfrey furnaces, with fixed rabblers and mechanically revolving circular hearths, are used for roasting, and large conical cast-iron pots for converting.

Edwards's roasting furnaces and large semispherical cast-iron pots are used at both the Zeehan and Chillagoe works. At the latter place the complex cupriferous and zincy lead ores have caused trouble in treatment.

Carmichael-Bradford Process.—This pot-roasting and desulphurizing process differs in several very essential features from the Huntington-Heberlein process. In it the raw sulphide ore, or concentrate, is mixed with partly dehydrated gypsum, wetted, dried, broken into lumps, and charged direct without previous roasting into converter pots, in which a small fire has been made in the bottom to start the action, which then continues without any external heat. The product is a well desulphurized, porous, sintered mass.

Flour, or ground, rock gypsum is dehydrated to 50 per cent. of its original combined water. It is heated on iron plates at a low temperature, and then put through a trommel to remove the lumps, which, in the case of the flour gypsum at Broken Hill, are silicious, and forthwith discarded. Three parts of concentrate, slime, or mixed concentrate and slime, and one part of partly hydrated gypsum, are mixed with a small amount of water in a pug mill, and passed through a trommel to ball it into lumps. The partly hydrated gypsum in the pug mixture combines with more water, and sets into very hard lumps. The surplus water is expelled by drying the lumps on a floor or drying furnace at a low temperature. The mixture is then ready to be fed into the converting pots. Pots suitable for the Huntington-Heberlein process will do equally well for this process, though they may with advantage be made deeper. A shovelful of embers, and then a bucketful or two of chips, are placed in the bottom of the pot, a gentle blast is turned on and when the charge is well lighted the granulated mixture is run in from a hopper, and the blast raised to about 8 to 12 ounces pressure. In about 10 to 15 minutes the action is going strongly, and SO_2 gas coming off freely. During the early stages of converting, the water is driven off, and condenses in the off-take flues. The action commences quickly, is soon going strongly, and continues thus to within a short time of finishing. The converting or cooking is complete in about 3 to 4 hours, and is appreciably quicker than in the Huntington-Heberlein process. The sintered material is tipped out on to the floor by inverting the pots. It is then cooled, broken up, and sent to the smelters.

The Carmichael-Bradford process requires very little attention to, and working of, the charge in the pots during converting. This process will readily treat the slime formed in the milling operations. One of concentrate, to three of slime makes an excellent combination for treatment by the Carmichael-Bradford process, whereas a mixture of one of concentrate to one of slime gives very indifferent results by the straight-out Huntington-Heberlein process.

The percentage of SO_2 in the gas given off in the Carmichael-Bradford process quickly rises, and remains high to very near the end of the process, rendering it suitable for the manufacture of sulphuric acid. In this respect it is superior to the Huntington-Heberlein process.

The plant required is less expensive than for the Huntington-Heberlein process, and where limestone and gypsum are both readily obtained it also has a less working cost per ton.

For localities where gypsum can be obtained at a reasonable cost, the writer considers the Carmichael-Bradford process is superior to the Huntington-Heberlein process both metallurgically and economically for treating leady concentrates, and more especially slimes.

Savelsberg Process.—In this process lead ores, mixed with a sufficient quantity of limestone, are fed directly into pots

without previous roasting, and desulphurized in one operation by blowing air through them. The reactions are started, as in the Carmichael-Bradford process, by a small amount of carbonaceous lighted fuel placed in the bottom of the pot.

For the best working of this process* it is claimed that the amount of limestone varies with the constitution of the ores, but in general amounts to about 15 to 20 per cent. of the charge. In order that the blowing in of the air may not cause particles of limestone to escape in the form of dust before the action begins, it is necessary to add to the charge a considerable amount of water, say, 5 per cent. or more. This water prevents the escape of dust, and it also contributes to the formation of sulphuric acid, which, by its oxidizing action, promotes the reaction, and consequently also the desulphurization. It is also advised that the chamber (pot) be gradually charged, i. e., in layers—as by this means the reaction takes place more regularly. While the chamber of a pot is being charged, air under low pressure ($2\frac{3}{4}$ to $4\frac{1}{2}$ ounces) is blown through, but when the pot is filled a larger quantity of air at a higher pressure ($11\frac{1}{2}$ to $13\frac{1}{2}$ ounces) is used. Scorification then takes place, a powerful desulphurization having preceded it. The desulphurization is completed during the scorification. When the process is completed or the charge "cooked," the pot is tilted, the fused mass falls out and is broken up into pieces for smelting. A typical charge at Ramsbeck is:

Lead ore, 100 parts; quartzose silver ore, 10 parts; spathic iron ore, 10 parts; limestone, 19 parts.

As in the Huntington-Heberlein process, the thorough mixing of the component parts is essential. The presence of pyrites in the ore is favorable to desulphurization.

The desulphurization of a charge is completed in about 18 hours, and requires the allowance of one man per pot. As compared with the Huntington-Heberlein and Carmichael-Bradford processes, as worked in Australia, the pot conversion is slow, viz., 18 hours, as against $3\frac{1}{2}$ to $5\frac{1}{2}$ in the former; while the labor is excessive, viz., one man per pot as against one man per five pots—but this may be due wholly or partly to the greater efficiency and capacity of the more highly paid Australian workman. A much larger converting plant and staff of men is therefore required.

Kapp-Kunze Process.—Another of the modifications of the Huntington-Heberlein process has been in operation in Zeehan (Tasmania) and Chillagoe (Queensland) for some considerable time—upwards of 4 years. It was brought out by Messrs. Kapp and Kunze, at Zeehan, where it has been worked under a veil of secrecy. As it has been held by law that lime roasting is an essential feature of the Huntington-Heberlein process, the modification of Kapp and Kunze should be considered, and is claimed to be, a distinct process. This process has, for short, been termed the K.-K. process.

The main features of the process are—the raw lead sulphide or cupriforous lead sulphide ore, broken to 2-inch cubes or less, is mixed with a determined quantity of hematite or iron gossan. The pots are the same as used in the Huntington-Heberlein, Carmichael-Bradford, etc., processes. A small amount of lighted carbonaceous fuel, as in the Carmichael-Bradford process, is placed in the bottom of the converter pots, a slight blast turned on, and a full charge of mixed ore and ironstone is fed in. As the desulphurizing action extends through the mass, the quantity of air is increased. The desulphurization, scorification, and sintering take place as in the previous mentioned processes, with a similar ultimate product. About 8 hours are required to convert and "cook" each potful.

Direct pot desulphurizing is not suitable for ores containing an appreciable percentage of zinc sulphide, as the desulphurization of the blende is not satisfactory, and causes trouble in the subsequent blast-furnace treatment. Ores containing an appreciable amount of zinc are therefore first roasted without

lime, and then cooked with ironstone in pots, as in the Huntington-Heberlein process.

McMurtry-Rogers Process.—This process is for desulphurizing copper sulphide ores and copper sulphide furnace products.

"The ore may be of any size, $2\frac{1}{2}$ -inch gauge down to fine slimes, but preferably the larger pieces should not exceed 1 inch gauge, nor is it advantageous that the charge should consist entirely of slime ore. The charge must contain silica or siliceous material amounting to from 15 to 35 per cent. of silica and from 15 to 25 per cent. sulphur, but the percentage may be somewhat greater or less without very materially affecting the operations of the process, it being also essential that the charge be wetted."*

The upper portion of the pots is more nearly conical than hemispherical, as in the Carmichael-Bradford pots at Broken Hill.

The operation is started by placing some lighted carbonaceous fuel on the bottom of the pots, turning on a slight blast, and then charging in the ore till the pot is about half full, the blast being increased until the ore becomes red, and then adding the balance of the charge.

The blast pressure is usually about 13 ounces, but ranges up to 20 ounces. The time to burn a charge varies from 8 to 12 hours.

Raw ore containing 20 per cent. sulphur is desulphurized down to about 5 per cent. sulphur. The cost of desulphurizing is about 87 cents per ton.

The sintered material is tipped out as a solid lump and

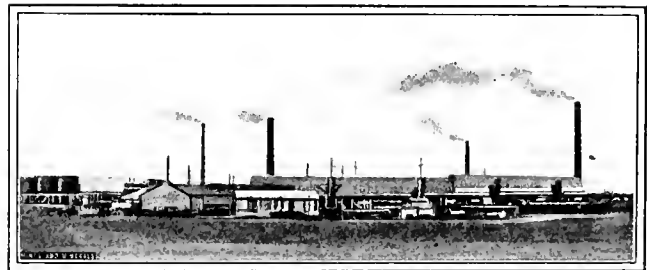

FIG. 3. SMELTER WITH WHARF IN BACKGROUND, PORT PIRIE

broken up as in similar pot processes into suitably sized pieces for treatment in furnaces.

The process has been installed at Wallaroo, South Australia.

Heap Roasting of Slimes.—The B. H. P. Company runs out its settled slimes in a semifluid condition as a layer about 6 inches to 1 foot thick over the ground, and it is left for several days to dry. While still in a plastic condition, the mass is cut with spades into rectangular blocks about 6 inches across, and left to dry into hard lumps containing about 1 per cent. of moisture. The lumps are loaded into trucks and railed to a spot about 5 miles out of the town, and here they are built into heaps and roasted. The heaps are about 20 feet wide, 7 feet high, and about 200 to 250 feet long. A central flue, to within a few feet of either end, is built of loose bricks along the ground, and side flues about 10 feet apart from the center flue to the sides. The lumps are packed into heaps of the above dimensions, with the sides battered back at about 60 degrees. The fines and small lumps are mixed in a pug mill, and used to plaster the sides and ends of the heaps, filling up all spaces and cracks, the surface being smoothed off. Wood fires are lighted in the side flues until the action has got well started. They are then discontinued, and the supply of air is regulated. The fire reaches all parts of the heap in 2 days. The heaps burn for about 8 days. The central portion of the heap has now sintered into a black porous mass, while the outer strip is of brownish, half-roasted material, which is built into the next heap. When cool, the heap is picked down, the mass broken up, loaded on to railway trucks, and sent to the metallurgical works at

* *Engineering and Mining Journal*, December 9, 1905.

* *Abstract, Trans. I. M. M.*, Vol. XVI.

Port Pirie. The portion rapidly takes up water of hydration and the powder, the slightly sintered lumps from the furnace, crumble into powder if exposed to the weather for a considerable time.

Mr. Clark gives the following interesting analyses.*

	Before Sintering Per Cent.	After Sintering Per Cent.
Lead	17	14.5
Zinc	16	12.5
Sulphur	12.5	7.1
Silver	17.5 oz. per ton	15.8 oz. per ton

About two-thirds of the sulphur is as sulphate and the remainder sulphide.

The losses in this sintering heap roast are approximately:

	Per Cent.
Lead	19
Zinc	29
Silver	15
Sulphur	45

It is seen that while the desulphurization is only moderate, the metal losses are very high, and much beyond what is to be expected; but the cause of such high losses is not clear. Although the loss of values is high in heap sintering, the product is one that can readily be treated in the blast furnaces, as the desulphurization is sufficient, and the physical condition

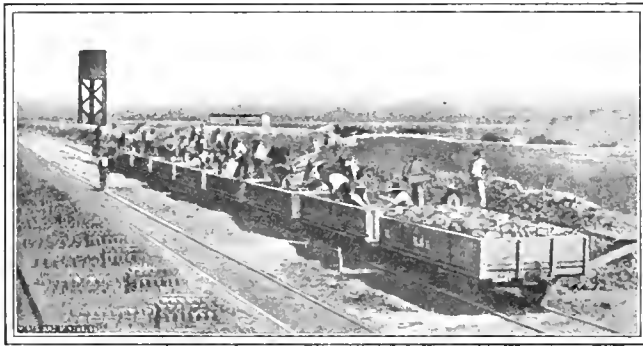
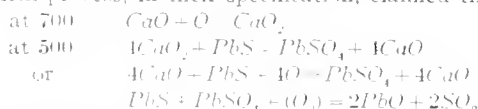

FIG. 4. HEAP ROASTING AND SINTERING NEAR BROKEN HILL.

is excellent. On the other hand, these slimes do not roast well in mechanically rabbled furnaces. They cause much dusting, and are by themselves untreatable by the Huntington-Heberlein process in use at Port Pirie. When more than a moderate amount of these slimes is mixed with ordinary lead concentrates, they prevent a satisfactory sintering in the Huntington-Heberlein process. As explained elsewhere, they give a satisfactory desulphurized and sintered product by the Carmichael-Bradford process. As this process is being installed, and is to be worked on a large scale at Port Pirie, it is probable that a large quantity of slimes will be treated by it, the extra cost of treatment being more than compensated by the improved recoveries of lead and silver.

Pot-Roasting Reactions—The reactions which take place in the Huntington-Heberlein and similar processes have been the subject of much discussion, in which there has been far from a unanimity of opinion. The patentees of the Huntington-Heberlein process, in their specification, claimed that



As metallic lead is sometimes seen in the sintered product of the process, no doubt the well-known reaction between oxides, sulphides, and sulphates also take place. This occurrence of metallic lead, however, seldom takes place, and then only to a small extent

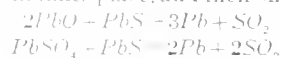

* Trans. Aust. Inst. of Mining Engineers, Vol. XII.

This explanation of the process has not been received with satisfaction, especially the reaction relating to the CaO_2 , which is decomposed at a low temperature. In a later communication* the patentees claim that the action of the CaO is catalytic, in the same way as spongy platinum, metallic silver, or oxide of iron. They also pointed out that the process will work well with Fe_2O_3 . This is certainly the case, as shown by the Kapp-Kunze modification successfully worked at Zeehan, and at the experimental plant at Chillagoe, and also more extensively in some of the installations in the United States of America.

There is little doubt that the reactions summarized by



also take place in the heated mass, as in heap roasting. It is also claimed † that the following reactions, resulting in calcium plumbate, take place:



and that the CaS is further oxidized to CaSO_4

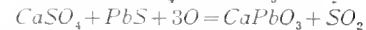

The presence of a fairly large percentage of silica is an essential to all pot-roasting processes, but its action and influence is rarely discussed. It forms silicates with iron and (or) calcium, and probably also with part of the lead, zinc, copper, etc., present in the various processes. In discussing the reactions, those leading to desulphurization are mentioned, whereas those leading to the scorification and sintering of the charge are nearly always neglected. Besides desulphurizing, the object of these processes is to obtain a product in a physical form suitable for blast furnaces, i. e., as lumps, not as fines. Desulphurized fines can be readily obtained by roasting in reverberatory furnaces.

The presence of water is also beneficial in these processes. It is taken up by the CaSO_4 of the Carmichael-Bradford process. Its addition as a wetting of the charge is a special feature of the Savelsberg and McMurtry-Rogers processes, and in the Huntington-Heberlein process it has been found beneficial to wet portion of the furnace-roasted product, and feed it on top of a bottom layer of hot material. In the Carmichael-Bradford process the patentees claim that the following reaction takes place:

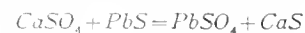

They also claim that CaPbO_3 is formed as a final product, and, in fact, much of the lead exists in that condition.

Savelsberg, ‡ in his patent specification, makes an interesting claim relating to the reactions due to lime, and these have not been disputed. They throw much light on the reactions of all the processes using compound of calcium as an essential feature. He says: "The limestone gives rise to chemical reactions. By its decomposition it produces lime, which at the moment of its formation is converted into calcium sulphate at the expense of the sulphur in the ore. The calcium sulphate at the time of slag formation is converted into silicate by the silica present, sulphuric acid being evolved. The limestone, therefore, assists directly and forcibly in the desulphurization by the ore, causing the formation of sulphuric acid at the expense of the sulphur in the ore, the sulphuric acid then acting as a strong oxidizing agent toward the sulphur in the ore." Calcium sulphate is formed during the furnace roast in the Huntington-Heberlein process, and its importance was overlooked. It is formed at an early stage of the pot blowing of the Savelsberg process, and its significance recognized, and it is made one of the starting points of the Carmichael-Bradford process. There is no doubt that the reactions which take place are many and varied under the thermal conditions, which vary from warm to white heat, the latter taking place at the slagging of the material. The desulphurized and slagged portions of the charge where action has ceased, are cooled by the cold air blast.

* Eng. and Min. Journal, May 20, 1906.

† Donald Clark, Aust. Mining and Metallurgy, page 440.

‡ Ingall's "Lead Smelting and Refining," page 123.

Milling at Stratton's Independence

Recent History of the Mine, Geology of Its Ore Deposits, and Milling of the Low-Grade Ores

Philip Henry Argall, M. A.

Stratton's Independence is the mine which made Cripple Creek, Colo., famous, and on no less than four occasions has it been vividly brought to the attention of miners and metallurgists: First, in 1895, by the discovery of the immense ore body between the second and fifth levels, and the production of ore so rich as to win for this area the name of the "Jewelry Shop." Second, the sale of the mine to the Venture Corporation of London, in 1899, for \$10,000,000. Third, the report that the mine was "worked out" in 1900, and again in 1907, followed by the big cave-in. Fourth, the successful milling of its low-grade ores in 1909 together with the rejuvenation of the mine.

Four years ago, gutted by company and lessees, the mine caved from the surface to the 500-foot level, taking with it some 10 acres of surface and the railroad tracks upon it, marking, in the general belief, the end of Stratton's Independence. The dawn of the year 1908 found the company heavily in debt and with an incompleting mill on its hands—in a seemingly hopeless condition.

The stockholders, however, with true British pluck and tenacity, subscribed a quarter of a million dollars to reopen their mine and complete the mill; the former an admitted forlorn hope and the latter freely acknowledged by the "wise ones" to be a "metallurgical impossibility."

The mill undertook the task of making a profit in milling \$4 sulpho-telluride ores, something that had not been accomplished anywhere before, and in spite of the fact that when handled on a large scale the ore was found to average a little over \$3 per ton instead of the expected \$4, nevertheless this low-grade refractory rock has been milled so profitably that the net earnings of the mine and mill have some time since exceeded the quarter of a million dollars subscribed to put the property in condition after the collapse of the mine workings.

It may perhaps prove mildly startling to the individuals who denounced the whole milling scheme because "every one knows that tellurides cannot be concentrated," and to the editors who wrote it down as a failure, when it is stated that the gross value of the concentrate and bullion, shipped from the mill during the fiscal year just past, reached in round figures one quarter of a million dollars.

The reopening of this famous old mine and the successful milling of its supposed worthless dump rock that had been accumulating for 18 years, emphasizes strongly two points, namely, the impossibility of carrying on successful mining without capital, and the importance of cross-cuts in Cripple

Creek mines. Without money to reopen the mine, to drive the levels through the caved area, and to complete the mill, Stratton's Independence would have been finished in 1908, and in all probability a hazy memory today. It took courage to raise money for further work in the face of such a disaster, and the credit for the successful outcome of today is in the largest measure due to the directors and stockholders, whose prompt action and belief in the mine enabled the work to go forward.

A clear definition of a mineral vein is always difficult and at best requires some slight modification for each mining district; but Cripple Creek veins require separate definition, distinguishing them from all others. The volcanic area contains sheeted zones, each sheet, or shear, often being a mineral vein—many of them but films; yet, an aggregation of these films makes, in Stratton's Independence, its principal veins. These films are not uniformly ore bearing, the ore affecting a shoot-like formation, hence, a small seam though barren when first discovered may in a few feet along its strike carry very rich ore. The object of cross-cutting in this formation is to prospect,

and while the mine has main cross-cuts on almost every level, ample perhaps for an average ore occurrence, nevertheless the production of the last two years is due entirely to two causes, the greater of which is the systematic testing of the ground by numerous cross-cuts, and the lesser, carefully prospecting every seam encountered in the cross-cuts.

The lesson to be learned from the reopening and thorough development of the Stratton's Independence mine is: First, one cannot make a success in mining without capital for development; and second, the absolute necessity for numer-

ous cross-cuts when prospecting a sheeted zone—not only on the main levels but in all available places between levels.

The sulpho-tellurides of Cripple Creek yield but a small percentage of their gold to hydro-metallurgical methods, unless roasting is a preliminary step. Roasting \$3 to \$4 ores with coal at \$6 per ton is, however, too costly to contemplate, so other methods had to be discovered looking toward the removal of the sulphur and tellurium as closely as possible and using oxidizing chemicals to attack the remaining tellurium which, owing to the friability of telluride minerals is usually found in the slime.

The scheme elaborated by Philip Argall in the spring of 1907, and laid before and approved by the directors of Stratton's Independence, Ltd., in June of that year, provided for: Crushing the ore in cyanide solution instead of water, in order that the cyanide could begin dissolving gold from the moment crushing began. Removing the tellurides as completely as possible by careful concentration conducted alike on the sand and slime. Leaching the sand in ordinary tanks to effect a further extraction and to wash out the remaining traces of cyanide. Treating the slime by air agitation and bromo-cyanide or other oxidizers

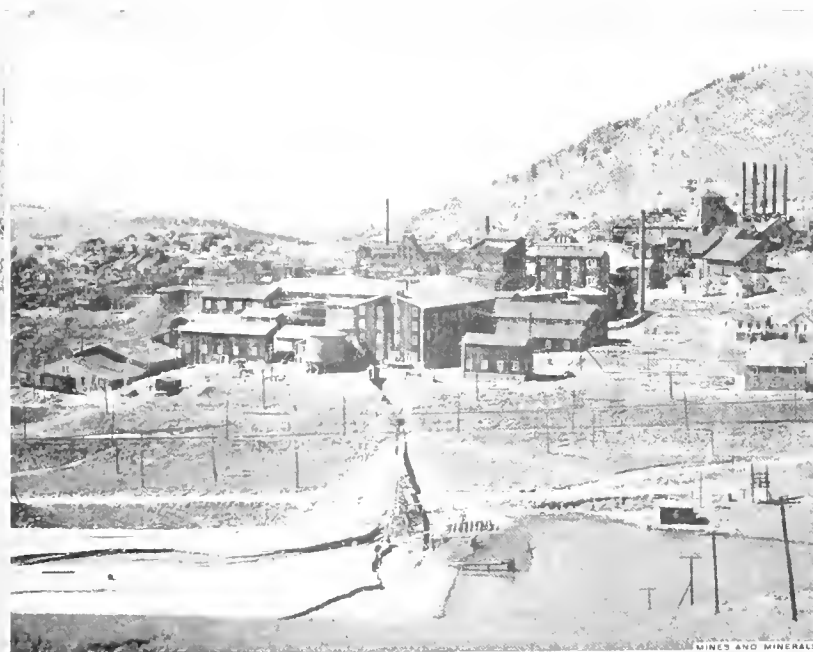

STRATTON'S INDEPENDENCE MILL

when necessary. A long and thorough series of full working tests have established bromo-cyanogen as the best solvent than any other cyanogen is at times useless, and always requires the usual chemical manipulation.)

Despite for a time through financial reasons, the mill started work in April, 1909; and has been ever since in continuous operation and is earning more than 10 per cent. per annum on the capital of the company.

The mill is run chiefly on dump material of ever changing composition; the recovery by concentration is therefore variable—low on partly oxidized ore and high on blue rock or straight sulphide. Yet, in the milling of over 200,000 tons the recovery by concentration has not fallen below 30 per cent., nor risen above 50 per cent. of the assay value of the ore. The general process is as follows:

The dump is mined by means of an electric shovel having a dipper of 1 cubic yard capacity, which discharges into 4-ton cars. An electric hoist draws the loaded cars to the top of the breaker plant where they dump automatically onto a large Gates gyratory rock breaker, which reduces the ore to pass a 4-inch ring. The discharge from this breaker passes onto a picking belt where the red granite (which is of no value) and odds and ends of old drills, bolts, drill steel, car wheels, etc. are removed. The belt discharges to a smaller gyratory breaker which crushes the ore to pass a 1½-inch ring, and discharges onto a conveyer belt, by which the ore is carried to the storage bin. Three hundred and fifty tons of ore are mined by the shovel, crushed and run into the storage bin in 6 hours, leaving the crew which performs this work available for other work two hours each shift.

From the storage bin the ore is drawn off and passed through two sets of 16"×36" rolls, after which it is delivered to the Chilian mill bins in about the size of a coffee bean. Four Akron 6-foot Chilian mills are installed, three of them being in use continuously while the fourth is kept in reserve. Cyanide solution is added at the Chilian mills, so that from this point on to the final filtering the ore is constantly in contact with cyanide solution and extraction is taking place.

The discharge from the Chilian mills passes into two Ovoca classifiers where the sand is separated from the slime, the former passing direct to Card concentrators and the latter, after thickening, to Deister concentrators. Here the sulpho-tellurides are removed as completely as possible, a high-grade concentrate resulting, which is shipped to the smelter, its high iron content and low silica offsetting the treatment charge to a considerable degree. It may be interesting to note here, that while chemical methods do exist wherein it is possible to treat this concentrate at the mill and obtain 90 per cent. extraction, yet, considering the value of the iron which is lost in the chemical treatment—there is no process known today which can compete with smelting on this product.

The sand tailing from the card tables is lifted by means of centrifugal pumps, to the leaching tanks in the cyanide department, where it is given four days treatment, then is washed carefully and sluiced to the tailing pond. The slime tailing from the Deister tables is also pumped to the cyanide department and is received in four large settling tanks, where the slime settles and the clear solution overflows to a storage tank, and later flows to the zinc precipitation boxes, where the gold is precipitated, and thence back to the Chilian mills. The thick slime from the bottom of the collecting tanks is pumped to a tank where it is treated first with cyanide solution, later by bromo-cyanogen solution if required, and is then pumped to the filter storage tank. A filter of the vacuum type then separates the solution from the slime, the solution passing to the zinc precipitation boxes and the slime being sent to the tailing pond. The precipitate from the zinc boxes is removed periodically, acid-treated to remove the zinc, dried, sampled, and shipped to the smelter. From the above brief outline the following points should be emphasized.

The Stratton Independence Co. has the first mill to successfully treat \$3 sulpho-telluride ores anywhere in the world. Concentration with the ore in cyanide solution. The closed circuit, that is, the solution is constantly in circulation from the Chilian mills, over the tables, through the tanks, through the zinc boxes and back to the Chilian mills. The use of bromo-cyanogen on the most refractory ores. The mechanical perfection, which enables 10,000 tons per month to be handled for a total labor cost of 45 cents per ton, everything included, repairs, lighting, and heating.

The difficulties to be overcome in handling dump rock are necessarily of varying composition. In handling ore direct from the mine, oxidized ore can be kept separate from sulphide ore and a feed of known composition can be milled; in a dump all kinds of ore material are jumbled together, and the composition varies hourly and leads to endless complications in concentrating.

The mill has made a profit from the start. Beginning with a capacity of 5,000 tons per month, it has finally reached 10,000 tons—though 15,000 can be milled by using the reserve machinery. It is preferred, however, to run steadily at 10,000 at a total cost of \$1.20 per ton milled, which should no doubt set the record for the treatment of \$3 ore. There are no secrets in the process, it being simply a combination of already well-known processes adapted to meet the conditions. The entire method has since been duplicated, and doubtless will be many times before all of Cripple Creek's \$3 ore is reduced to worthless tailing.

Stratton's Independence is today in better condition than it has been at any time in the past 5 years. Need I add, that the capital pluckily thrown into this old property in the hour of its extremity, has not only been handed back to the contributors in the short space of a couple of years (a remarkable performance for any mining district) but, the stockholders have now a property that will provide dividends for many years to come. And instead of innocuous desuetude around the base of Battle Mountain, there is a busy industry, employing about 250 men with a pay roll, including lessees, of \$30,000 per month. Furthermore, this district has been provided with a cheap milling process for its low-grade ore, something of incalculable value to the mine owners of today, and to the future operators in this great mining district.

采 采

Mining in Uruguay

A recent Consular Report states as follows: The mineral wealth of Uruguay is beginning to attract the attention of the capitalists of Europe, for within its limits is to be found nearly every known mineral. To ascertain the boundaries of the coal-bearing area in the Department of Cerro Largo, borings were continued during 1910 in the vicinity of Canada de los Burros, the results being satisfactory. A deposit of pure mica has been discovered in the Department of Canelones, 2½ miles from Toledo station.

The Uruguay Manganese Co.'s petition for a concession, including 10 years exemption from export duties, has been granted, and authority has been given for the construction of a branch railway to the locality. The work of developing the mines in order to prove definitely the quality and quantity of the ore is being actively advanced; the analyses of the samples obtained from the deepest cuts reached about 49.8 per cent. of metallic manganese, with 1.8 per cent. of silica. The Uruguay Consolidated Gold Mines Co. has a property consisting of five concessions, each with area of 208 acres (84 hectares, the limit allowed by the mining code). In one shaft, at a depth of 1,500 feet, the lead is said to vary from 25 to 80 feet, disclosing a large body of ore; others range from 8 to 35 feet, while the surface outcrop frequently shows valuable ore. The estimated value of ore is \$4.38 per ton.

Mines and Minerals

Vol. XXXII—No. 6. SCRANTON, PA.—JANUARY, 1912—DENVER, COLO. Price, 25 Cents

PUBLISHED MONTHLY AT SCRANTON, PA.

ESTABLISHED 1881

WESTERN EDITORIAL OFFICE: 1221-1222 First Nat'l Bank Bldg., Denver, Colo.
CHICAGO OFFICE: 1006 Michigan Ave.

Entered at the Post Office at Scranton, Pa., as second-class matter
Address all business communications to MINES AND MINERALS, Scranton, Pa.
CABLE ADDRESS, "RETSOP, SCRANTON"

LONDON OFFICE: INTERNATIONAL BUILDINGS, KINGSWAY, LONDON, W. C.
SOUTH AFRICAN OFFICE: MANSION HOUSE CHAMBERS, ALDERLEY STREET, CAPE TOWN.

NEW ZEALAND OFFICE: 63 DIXON STREET, WELLINGTON.
AUSTRALASIAN OFFICE: 83 PITT STREET, SYDNEY.

SUBSCRIPTION RATES

Single Copies.....25 cents
Yearly Subscriptions, including postage:
To United States, Mexico, Cuba, Porto Rico, Hawaii, and Philippines \$2.00
To Canada.....2.50
To all other countries.....3.00

The date after your name on the wrapper is that of the month to which your subscription has been paid. If you do not want to continue your subscription after that time, kindly notify us.

Notice to discontinue or change of address should be sent to the Scranton office.

When notifying us of a change of address always give your former as well as your present address.

TABLE OF CONTENTS

EDITORIAL—

Flushing or Silting Mine Workings—The Briceville, Tenn., Coal Mine Disaster—Portable Electric Lights for Mines..... 321

PERSONALS..... 323
MINING EDUCATIONAL INSTITUTES..... 323
HISTORY OF THE FIRST-AID MOVEMENT..... 324

COAL MINING AND PREPARATION

MODEL STEEL TIPPLE AT ANNABELLE MINES, by Wm. Archie Weldin..... 325
BOTTOM CREEK MINE EXPLOSION..... 332

FIRST-AID WORK AND FIRST-AID CONTESTS, by E. D. Burkhard, M. D., and Samuel Dean, M. I. M. E..... 334

USE OF OXYGEN HELMET IN HIGH TEMPERATURES, by H. H. Sanderson..... 335
TRACK ARRANGEMENT FOR SHAFT BOTTOMS, by Oscar Cartledge..... 336

COLLIERY GAS ENGINE PLANTS, by Frank C. Perkins..... 337
TRADE NOTICES..... 338

ADVANCE IN AIR COMPRESSION..... 339
THE CARBONDALE MINE FIRE, by F. W. Brady..... 340

TESTING GASOLINE MINE LOCOMOTIVES..... 341
EXTINGUISHING THE MAJESTIC MINE FIRE, by R. Y. Williams..... 342

SHAFTS FOR AMERICAN COAL MINES, by R. G. Johnson..... 344
VICTOR-AMERICAN FUEL CO.'S INSTRUCTION CAR..... 348

CRUSHING COAL FOR BOILER USE..... 349

CORRESPONDENCE—
Siphon—Coal Dust Explosions and Air—Car Spotter..... 350

COAL MINING NOTES..... 351
BOOK REVIEW..... 352

EXAMINATION QUESTIONS—
Indiana Examinations, Terre Haute, 1911..... 353

ORE MINING AND METALLURGY

METALLURGY OF MERCUR GOLD ORES, by Theo. P. Holt..... 355
GEOLOGIC STRUCTURE OF SILVER DISTRICTS, by W. G. Matteson..... 358

ELECTROLYTIC REFINING, by Edward B. Durham..... 361
ESTIMATING ALKALINITY IN LIME..... 368

PRESIDENT TAFT IN HOMESTEAKE MINE..... 369
EXHAUST STEAM TURBINES AT MINES..... 370

MINING IN THE TINTIC DISTRICT, UTAH, by Leroy Palmer..... 375
ORE MINING NOTES..... 378

CATALOGS RECEIVED..... 380
TREATMENT OF BROKEN HILL ORES, by Wm. Poole..... 381

HISTORY OF KANSAS OIL DEVELOPMENT, by L. L. Wittich..... 382

SQUIBS—
Garnet Veins on Labrador Coast, 357—Silver Mining in Peru, 360—
Slate and Marble in Newfoundland, 367—Bauxite Production, 1919,
369—Mining Fields of Peru, 369—Irrigation with Artesian Waters
in Australia, 374—Tin Mining in the Federated Malay States..... 374

Flushing or Silting Mine Workings

IN the October number of *The Mining Magazine* (London, Eng.), Mr. Edgar Pam, in an article entitled "Water-Borne Packing for Stope-Filling" says: "This process, commonly known as "sand filling" was started in Silesia in 1901, and its value has been proved by the rapidity with which it has been introduced all over the mining world. * * Many collieries in Silesia, Westphalia, and France are employing this method of filling their workings; the majority of the mining groups on the Witwatersrand have adopted it, and from private information and current literature it appears that a large number of mines in Scotland and the United States are falling into line."

The above statement, while not a direct claim, is a very strong inference that the filling of old workings with sand or other material flushed in with water originated in Europe. Such an inference, however, is at variance with facts.

In 1886, the workings of the Kohinor colliery under the western part of the borough of Shenandoah, Pa., threatened to destroy the surface and the buildings thereon. The Mammoth seam at the Kohinor colliery was in this locality normally from 50 to 60 feet thick, but owing to an overlap there was a bed of fine anthracite from 100 to 120 feet thick.

The Philadelphia & Reading Coal and Iron Co. owned the colliery, having purchased it several years previously from Messrs. R. Heckscher & Co. Most of the mining in the territory mentioned was done by the original owners, and the real extent of the mine openings was not shown on the mine maps, until a new and more accurate map was constructed from surveys by the engineers of the Philadelphia & Reading Coal and Iron Co. It was evident from this map and the fact that a geological cross-section showed less than 400 feet of cover over the seam, that there was some danger of a heavy subsidence of the surface.

At this time (1886) the late R. C. Luther was Chief Mining Engineer for the Philadelphia & Reading Coal and Iron Co., and he conceived the idea of putting 8-inch bore holes from the surface to the higher points in the mine workings, and of flushing culm down these bore holes to fill up the very large cavities. There were large culm piles at the colliery, so scraper lines were constructed running from the culm piles to the bore holes, and water was pumped to them from a neighboring creek. Men at the culm piles screened the culm before it was sent to the bore holes by the scrapers, and men at the bore holes fed it into the holes as fast as the water would carry it down. After the water drained off from the culm it flowed by

gravel to the surface and was thence pumped to the surface. In course of time all the openings were filled, and the plan of the idea has been proved by the fact that 25 years have elapsed since the work was done, and there has been no subsidence of the surface where the culm was packed into the workings.

The surveys and geological cross-sections, and the locations of the several bore holes required, were made under the supervision of Mr. John H. Pollard, then Resident Engineer of the Shenandoah District, and now Division Superintendent of the Mahanoy Division of the P. & R. C. & I. Co.

Thus, in 1886, fifteen years before the plan was adopted in Silesia, it was successfully used in Pennsylvania. Some 2 or 3 years later Mr. James B. Davies, then superintendent of the Haddock collieries at Plymouth, Pa., knowing of the results of the work at the Kohinoor colliery, successfully used the same method, and he also antedated the Silesian engineers.

It is interesting to also record the fact that at the Kohinoor colliery the culm in the mine packed so solidly that gangways or headings were driven through it and the miners reported that it "cut like cheese." The forepoling method of timbering was naturally used in these gangways and through them several hundred thousand tons of coal was mined from the larger pillars, and the new excavations were then filled with culm in the same way. The process was described in MINES AND MINERALS, then known as *The Colliery Engineer*, in the early part of 1888.

來 來

The Briceville, Tenn., Coal Mine Disaster

THE explosion in the Cross Mountain No. 1 mine at Briceville, Tenn., on December 9, was one of the most disastrous, so far as human life is concerned, of the year. As is usual, the first work of the officials of the mine and those of neighboring mines, and also of the rescue corps of the United States Bureau of Mines, under the personal direction of Doctor Holmes, which was early on the ground, was devoted to efforts to rescue such of the mine workers as might be alive, and to recover the bodies of the dead. The inquiry into the cause of the explosion is a matter for subsequent investigation. In the rescue work a commendable spirit of bravery and disregard for personal safety, modified of course by rational precautions, was displayed. MINES AND MINERALS was early represented on the ground, and in the next issue a detailed illustrated account of the accident, showing if possible the cause, and the methods employed in rescue work will be published.

Until full investigation is made, there can be no positive statement as to the cause of the explosion. But as the mine was an extensively worked drift mine, evidenced by the fact that the gathering point from which trips were hauled by the electric motor is 6,600 feet from the drift mouth, that the analysis of the coal shows 40.05 per cent. of volatile hydrocarbons, and that the mine

was classed as a dry and dusty mine, it is probable that the explosion was primarily due to a blown out shot, and was extended by dust. The seam worked in the mine has an average thickness of 46 inches with a slate roof and fire-clay bottom. The ventilation was produced by a 7-foot diameter exhaust fan run by electricity at a speed of 300 revolutions per minute. This fan was 3,100 feet inside the mine and exhausted up an air shaft.

The mine was classified as one which the Chief Mine Inspector or a District Mine Inspector shall inspect and examine at least once every 60 days, and determine if it is operated under the restrictions of the Tennessee Mine Law. Reports received show that such inspections were made by the state officials but a short time before the explosion, and by the operating company's own inspector the day preceding it.

What precautions were taken to neutralize the presence of the dust, and how well the means adopted were carried out, will no doubt be thoroughly investigated, and until the results of such investigations are available it would be unjust and foolish to attempt to fix the responsibility for the disaster either on the operating company, its officials, or any workman.

來 來

Portable Electric Lights for Mines

IN view of the fact that well-designed self-contained portable incandescent lights operated by storage batteries are absolutely safe in explosive mine atmospheres, and that they are now constructed in convenient shapes and of comparatively light weight, it seems as if their adoption by mine managers has been slower than conditions warrant. The first portable incandescent lamps, produced some years ago, were too heavy, inconvenient in size and too unreliable to win universal favor. However some mine managers used them for special occasions and especially for mine rescue work.

The miner's electric lamps, designed to be worn on the cap, now on the market, are great improvements on those first produced and have been proved convenient and reliable by several large mining companies, as has been recorded in our columns. These lamps consist of bulbs attached to light and efficient storage batteries which are recharged each day.

While the incandescent lamp is safe in an explosive atmosphere, it will not detect the presence of gas and, therefore, its use is limited to the functions of a *working* lamp. In other words, a lamp for all the miners and other inside workmen who are not expected to perform the duties of a fire boss.

The incandescent lamp will not show the presence of carbon dioxide or black damp as will an exposed flame, which will either become dim or be entirely extinguished in such gas. Therefore, while not an instrument by means of which the presence of such gas can be detected, it is a most excellent illuminant in rescue work in conjunction with the approved types of oxygen apparatus, and is used

in conjunction with such by the rescue corps of the United States Bureau of Mines and those organized by various mining companies.

As a working lamp for gaseous mines, the portable electric lamp is a success, and when used in connection with "permissible" explosives, it will be a preventative of serious accidents.

It may be said, that the electric light will not warn the miner using it of the presence of gas in an increasing and dangerous quantity, but it must be borne in mind that the average mine worker pays but little attention to the flame in his lamp while at his work; the light which will not ignite the gas is safer in his hands than one which, while capable of detecting gas, is not only a less efficient illuminant, but also a source of danger in the hands of ignorant or careless men.

Personal

Personal

P. H. Dowler, of Heilwood, Pa., gave a dinner to the Pennsylvania delegation at the American Mining Congress in Chicago. They in turn presented him with the assurances of their most distinguished consideration in the form of a silver loving cup on which a suitable inscription was engraved.

W. H. Henderson and Eugene Henry, members of the Crozer Land Association Engineer Corps were killed in an explosion of gas in Bottom Creek coal mine, Vivian, W. Va., on November 18.

The portrait of Col. E. D. Meier, Ex-President of the American Society of Mechanical Engineers, is on exhibition at the Engineers' rooms in New York City. This oil painting was subscribed for by the members of the institute to commemorate the esteemed consideration in which he is held. Mr. Meier is now 71 years of age.

Sidney G. Koon, M. M. E., former editor of *International Marine Engineering* and later metallurgist with Jones & Laughlin Steel Co., is now associated with Walter B. Snow, 170 Sumner St., Boston, Mass.

B. L. Thane, manager for the Kensington Mining Co., has been appointed manager of the Alaska Perseverance mine in the Juneau district.

Wm. B. Phillips, Director of the University of Texas Bureau of Economic Geology and Technology, Austin, Tex., is issuing letters in the interest of the mineral industry of Texas.

W. E. Duncan, M. E., M. I. E. E., consulting engineer of Merritt, B. C., has compiled for private circulation an interesting pamphlet on British Columbia Coal and Coke.

James F. McCarthy, of Wallace, Idaho, has been president and manager of the Hecla Mining Co. since the death of J. R. Smith, of Chicago, Ill.

W. T. Tracy, of Galesburg, Ill., recently acquired control of the Amazon-Manhattan mine in the Sunset district near Wallace, Idaho.

Norman Ebbley, of Wallace, Idaho, will have charge of the Nipsic Co.'s development in the Coeur d'Alenes district. This property has just been through 7 years of litigation.

Dr. Alex. C. Humphreys, of Hoboken, N. J., is president of Stevens Institute and also of the American Society of Mechanical Engineers.

A. F. McClaine, president Traders National Bank, Spokane, Wash., is virtually head of the Rambler-Cariboo.

Lewis E. Aubury, State Mineralogist of California, who so long and successfully combated the timber thieves and mine fakers in California has been deposed by Governor Johnson.

W. H. Storms, of Berkeley, Cal., has been appointed State Mineralogist by Governor Johnson to replace Lewis E. Aubury. Mr. Storms' work is already cut out for him, as he will be obliged to antagonize grafters and fakers from the start of his administration.

E. M. Marshall, B. S., is specializing on cyaniding at Massachusetts Institute of Technology, Boston.

Dr. Walter Fraenkel, Ph. D., Heidelberg, 1908, is specializing on the reduction of lead oxides at Massachusetts Institute of Technology, Boston.

Dr. W. Wanjakow, a graduate, 1906, of the Russian Imperial Technical Institute of Tomsk, Siberia, is specializing on the decomposition of sulphates by means of heat at Massachusetts Institute of Technology, Boston.

Boyd Dudley, B. S., M. S., is specializing on chlorodizing-roasting of ores. He is trying to determine the temperature at which the leading reactions take place. This work he hopes will prove to be valuable in suggesting a method of separating nickel and copper by a modification of the Longmaid-Henderson process.

John S. Nicholl, B. S., one time manager for F. W. Horne, Yokohama, Japan, is now associated with W. B. Snow, 170 Sumner St., Boston, Mass.

Walter W. Davis, formerly of the Yak tunnel, has gone to Aspen, Colo., to take charge of the Smuggler properties that have been unwatered through the Free Coinage shaft.

Prof. G. W. Schneider, of Colorado State School of Mines, addressed a gathering of Leadville mine operators recently on "The Application of Business Principles to Mining."

John G. Coryell, president of the Coryell Coal and Iron Co., died at Williamsport, Pa., on November 3 at the age of 50 years.

The York Coal and Coke Co., of Ashland, Ky., has been incorporated with a capital of \$250,000. The incorporators are John F. Hager, J. J. Johnson, E. P. Price, K. M. Fitzgerald, of Ashland, Ky., and James Sowards, of Pikeville.

The Patten Coal Mining Co., of Hamilton, Tenn., has been incorporated by T. A. Leyshorn, of Barnes; B. D. Turman, W. B. Stewart, and James M. Adams.

V. M. Taylor, of Brockwayville, Pa.; T. M. Kurtz, Punxsutawney; and Fred B. Henderson and E. B. Henderson, of Brookville, Pa., have organized the McKnight Coal Co.

H. P. Dowler, superintendent of the Penn-Mary mine at Heilwood, Pa., is having a building erected as a practice and storage room for first-aid equipment.

Personal

Mining Educational Institutes

The Colorado School of Mines, jointly with the Colorado Scientific Society, has inaugurated a series of practical talks to mining men which are being held at the various mining camps throughout the state. The first meeting, late in October, was held at Idaho Springs, where Chas. A. Chase, general manager of the Liberty Bell Gold Mining Co., of Telluride, read a paper on "Mine Management." The second meeting was held early in November, at Leadville, where Prof. Geo. W. Schneider, of the Colorado School of Mines, read a paper on "The Application of Business Principles to Mining." The third meeting was held in Telluride on December 8, where A. E. Anderson read a paper on "Recent Developments in Explosives." The sessions were well attended and in addition to the reading of the more formal addresses many impromptu discussions took place upon subjects of general interest. These trips afforded those interested an opportunity to visit the more prominent mines and mills of the various districts under unusually favorable circumstances.

West Virginia Coal Mining Institute.—The winter meeting of the West Virginia Coal Mining Institute was held at the Masonic Temple, Fairmont, W. Va., December 4, 5, and 6, 1911. President Frank Haas opened the exercises with an address. This was followed by Judge W. S. Haymond and E. M. Showalter, Esq., who welcomed the delegates to Fairmont in behalf of the Chamber of Commerce. Responses were made in behalf of the Institute by the vice-presidents and directors. During the business sessions the following papers were read: "The Relationship of Manufacturers to Operators," by F. C. Albrecht, E. E., Westinghouse Electric and Mfg. Co., Pittsburg, Pa.; "A Method of Testing for

Black Day," by W. R. Crane, E. M.; "Technical Education With Special Reference to Mining Interests," by Dr. T. C. Hodges, President West Virginia University; "A History of the Fairmont Region," by Ex-Governor A. B. Fleming; "A Mine Foreman," by John Laing, Chief of the Department of Mines; "Forestry for Mining Companies," by R. C. Eggleston, forester, Consolidation Coal Co., Jenkins, Ky.; "Recovery of Coal From the No. 2 Gas Seam in the Kanawha District," by James J. Marshall, Chief Engineer, Loup Creek Colliery Co., Page, W. Va.; "The Economical Production of Steam in the Operation of Coal and Coke Plants," by Chas. N. Hays, Pittsburg.

The following were elected officers for the ensuing year: Frank Haas, President, Fairmont, W. Va. Vice-Presidents, Neil Robinson, Charleston, W. Va.; George Watson, Fairmont, W. Va.; John Laing, Charleston, W. Va.; J. F. Healy, Elkins, W. Va. Executive Board, Lee Ott, Thomas, W. Va.; C. R. Jones, Morgantown, W. Va.; J. J. Lincoln, Elkhorn, W. Va.; Daniel Howard, Clarksburg, W. Va. Secretary-Treasurer, E. B. Day, Pittsburg, Pa.

Short Session for Mining Men.—For the fifteenth time in its history, the College of Mines of the University of Washington will hold its short session for mining men, beginning on January 4, 1912, continuing to April 1. This course is open free of charge to all mining men who wish to spend the "lay-off" season in taking up courses in mining, milling, mineralogy, geology, chemistry, assaying, metallurgy, mine surveying, mining law, and other related subjects. Opportunity is given the men entering these courses to visit the mines, smelters, and plants near Seattle, Tacoma, and Everett; and to make free use of the milling and metallurgical laboratories to concentrate and test their own ores. Courses in coal mining, given in conjunction with the mine-rescue work at the Bureau of Mines Station, are offered to coal-mining men. Particulars regarding the course can be obtained by addressing Dean Milnor Roberts, Mines Building, University of Washington, Seattle.

Coal Mining Institute of America.—The winter meeting of the Coal Mining Institute of America was held at Pittsburg, Pa., December 19-20, 1911. All sessions were held in the Engineers Society of Western Pennsylvania Rooms, Oliver Building, corner of Sixth and Smithfield Streets. On the morning of the 19th a business session was held. Thomas K. Adams, State Mine Inspector, presided over the question box, and the entire afternoon was devoted to the discussion of live practical questions submitted by members of the Institute. In the evening a joint meeting was held with the Engineers Society of Western Pennsylvania, at which an address was made by Walter Riddle, president of the Engineers Society of Western Pennsylvania, after which a paper on "Power Plants With Special Reference to Requirements in Western Pennsylvania," was read by O. S. Lyford, Jr., and R. W. Stovel, engineers with Westinghouse, Church, Kerr & Co., New York City. These were illustrated with lantern slides. On Wednesday the following papers were read: "A Remarkable Coal Formation," by Jesse K. Johnston, Charleroi, Pa.; "Special Methods of Testing for Mine Gases," by W. R. Crane, Dean of the School of Mines, Pennsylvania State College; "The Construction and Maintenance of Telephone, Signal, and Trolley Lines in Mines," by E. M. Weir, Western Electric Co.; "Application of Gas Analyses in Coal Mines," by G. A. Burrell, chemist, United States Bureau of Mines; "The Price of Coal Compared With the Price of Materials Used in Mining," by E. N. Zern, Assistant Professor of Coal Mining, University of Pittsburg; "Electrical Symbols for Use on Mine Maps to Indicate the Character and Location of Electrical Apparatus," by H. H. Clark, electrical engineer, United States Bureau of Mines, and Mr. Randolph of Wood & Randolph, electrical engineers of Pittsburg; "Lignite Mining in Colorado," by C. J. Griswold, Assistant Professor of Mining, Carnegie Technical School, Pittsburg. In the evening an institute dinner was held, after which an address was made by President S. A. Taylor on "The Coal Fields of the World, With Some Statistics and Data Thereon."

The following officers were elected for the ensuing year: President, A. W. Calloway, General Superintendent Rochester & Pittsburg Coal and Iron Co., Punxsutawney, Pa.; first vice-president,

Jesse K. Johnston, Charleroi, Pa.; second vice-president, W. E. Fohl, E. M., Pittsburg, Pa.; third vice-president, Elias Phillips, State Mine Inspector, Du Bois; secretary and treasurer, Chas. L. Fay, Wilkes-Barre. Board of Managers, James Semfield, Lister, Pa.; Nicholas Evans, Punxsutawney, Pa.; S. A. Taylor, Pittsburg.

采 采

History of the First-Aid Movement

In Johnson & Johnson's First-Aid Manual, page 61, there is a cut of Esmarch's triangular bandage on which appears several men with different kinds of bandages. The cut being somewhat familiar, it was traced back through the Pennsylvania Mine Inspectors' Report, which appeared in Part 3 of the Annual Report of the Secretary of Internal Affairs in 1882-3. Here credit is given to Gwilym M. Williams, Inspector of Mines for the Middle Anthracite District in 1882. Looking up this reference we find that Mr. Williams refers to the late Peter Shepard, M. D., who prepared a concise little book of instruction on "Aids for First Help to the Injured." This was published prior to 1879 by the St. John Ambulance Association, of London, and also a pocket aide-memoire from which Mr. Williams' extracts were taken.

In 1881 the Shenandoah *Herald*, the grandfather of MINES AND MINERALS, published a Mine Foremen's Pocketbook, in which will be found rules for resuscitating the injured, and in 1883 another of these pocketbooks contained cuts of "How to Care for the Wounded." The writer is of the opinion that he saw Prof. S. Esmarch's first bandage in a North of England Institute of Mining Engineers Report, published prior to 1881. Mr. Williams, in 1882, had this to say on first-aid to the injured:

"During the last 2 or 3 years I have been deeply impressed with the thought that a little more education regarding the best manner of treating injured persons before, and while being removed to their homes and until the arrival of a physician, would contribute much toward alleviating the pains of those unfortunate fellows who are injured. I have no doubt that many persons' sufferings are intensified and prolonged, and most probably some die, by not having proper treatment immediately upon receiving the injuries. The prevailing custom when a man is injured is to remove him home at once and send for a surgeon. No examination is made of the nature of his injury. A vein or artery may be cut, but it is not discovered until the surgeon arrives, and perhaps when it is too late to save the unfortunate person's life. A limb may be broken and the broken ends of the bones are left to pierce the flesh at every step while he is being conveyed home.

"To many poor fellows with broken limbs their shifting in and out of cars incident to removing them home has been a severe ordeal, intensely painful. The miners are generally willing and ready to make any sacrifice for the comforts of any injured comrades and are ready to handle them with care and tenderness, but they do not know anything concerning the best manner of treating the injuries of the person so as to hasten his recovery and relieve his sufferings during the moving.

"I think if physicians of mining districts could be induced to take interest in this humane question and give free lectures to the people connected with coal mines, instructing them in the best manner of treating injured persons prior to the arrival of a surgeon, they would contribute greatly to allay the torture and pains of their unfortunate fellow beings who are victims of mine accidents."

He next quotes from Doctor Shepard's book on "Aids for First Help to the Injured, Wounds Bleeding From Arteries, Treatment of Broken Bones," and has this to say of Esmarch's triangular bandage: "This bandage is a triangular piece of unbleached calico; the lower border measures 4 feet and the two side borders 2 feet 10 inches each. It can be applied in 32 different ways; it answers every purpose for temporary dressings and the means of making one are always at hand, namely, a pocket handkerchief cut diagonally in two. Its application is so easy that a look at the accompanying diagram will enable any one to use it in the manner indicated in the illustrations."

COAL MINING AND PREPARATION

Model Steel Tipple at Annabelle Mines

An Example of the Newest Methods in Building Construction and in the Methods of Handling Coal

By Wm. Archie Weldin, C. E.*

The Annabelle No. 1 mine of the Four States Coal and Coke Co. is a new mine just put into full operation. The plant is situated in the valley of Tevebaugh Creek, about 3 miles above the village of Worthington, in Marion County, W. Va., and about 10 miles from Fairmont. The principal offices of the company

are at Pittsburg, Pa. The corporation is commonly known as one of the "Jones interests," a term applied to a group of mining companies officered by four brothers of that name. Of these corporations, probably the most widely known is the Pittsburg-Buffalo Co., whose recently equipped Marianna mine is generally recognized as being

one of the most advanced coal-mining installations in the world. The men at the head of these corporations take pride in keeping their organization and equipment fully up to the most progressive standards

The new Annabelle mine is no exception to this rule, and in its design every effort has been made to take advantage of all the newest developments in equipment and methods, so that it may be said to truly represent the "state of the art" today.

The coal mined is of the well-known Pittsburg seam, which here occurs in exceptional purity. A thickness of about 7 feet is mined. The coal lies about 300 feet below the valley, and is reached by two concrete-lined shafts, one of which is used for hoisting and the other for ventilation. Mine No. 2 will be contiguous to No. 1 and will be reached by a slope. The power plant will serve both mines. It is housed in a neat and substantial fireproof building situated between the shafts. The boiler room contains seven 500-horsepower Stirling boilers, equipped with Jones underfeed stokers having automatic feed and draft. The power room contains two high- and two low-pressure compound air compressors, and two Westinghouse generators with switchboard for lighting. The compressors furnish the power for all the underground machinery, including Ingersoll-Rand heading machines, Jeffrey chain and puncher mining machines, and Baldwin compound locomotives. The Vulcan hoisting engine and the Connellsville ventilating fan are housed in continuations of the main building. The fan is

worthy of note on account of its size, being 35 feet in diameter and 8 feet wide.

Aside from the ventilating fan, the tippie is, of course, the principal feature belonging exclusively to the coal-mining industry, and therefore is selected for detailed description in this article. The structure was designed for a capacity of 3,000 tons in 8 hours. Even for this capacity the tippie is unusually large, owing to the extent to which the processes of coal preparation are carried, and the amount of machinery installed for this purpose. The design was prepared by the regular staff of the company, D. G. Jones, president, giving it close personal attention. The adopted arrangement is the result of Mr. Jones' long experience and thorough knowledge of mining practice, which especially fits him to direct such work.

Complete design drawings and elaborate specifications were prepared by A. C. Beeson, chief engineer. A contract was let to the Jeffrey Mfg. Co., of Columbus, Ohio, which covered the furnishing of the entire structure and equipment. This included not only the buildings, screens, dumps, conveyers, etc., but also the hoisting ropes, cages, transfers, driving engines, steam and

water piping, each being carefully specified in detail, even to the electric lighting and signal systems. The contracting company in fact furnished everything necessary for the operation of the tippie and turned it over to the coal company in running order. This arrangement proved eminently satisfactory and resulted in placing the tippie in operation at once on completion, without the delays usually incident

to these installations. Of course, the success of such an arrangement depends upon the inclusion of every necessary item in the contract, and careful and complete specifications as to the exact nature and quality of all the work. Omissions or lack of definiteness in specifications of this nature are especially likely to give rise to disputes.

The tippie is a steel structure of very heavy design. It consists of the tippie proper, which contains the dumps, kickbacks, transfers, and pushers for handling the mine cars, as well as the shaking screens for separating the lump from the fine coal; the picking room, housing the two picking bands which receive the lump coal from the shaking screens and deliver it to the railroad cars, and the rescreening tower, in the top of which are located the revolving screens which separate the nut and slack. The fine coal is elevated to these screens from the shakers and flows from them in closed chutes by gravity to the cars, the picking bands, or to the boiler-fuel conveyer. These chutes are so arranged that all

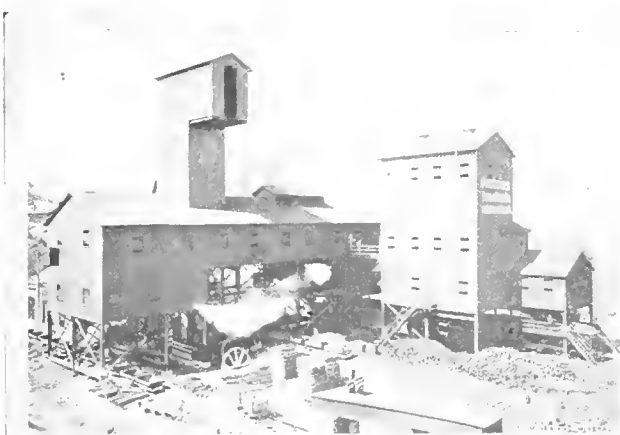

FIG. 1. BACK OF TIPPLE, ANNABELLE MINE



FIG. 2. FRONT OF TIPPLE, ANNABELLE MINE

*Designer, Four States Coal and Coke Co., Pittsburg, Pa.

possible combinations of the different sizes can be made to suit market requirements. About half way to the top of the screening tower and immediately over the end of the picking room is an auxiliary screen room containing a revolving screen adapted to divide the slack into pea and dust. The refuse from the picking bands falls into a plate conveyer running in the opposite direction to that of the picking bands. This refuse conveyer discharges into a transverse conveyer, which delivers into a crusher located in a pit below the surface of the ground. From this crusher the refuse is elevated by a scraper conveyer to the fuel bins in the boiler house, from which it flows to the automatic stokers of the boilers.

In Fig. 2 is shown one side of the tippie. To the right is the brick power house with the inclined conveyer that carries the coal from the crusher to the conveyer over the boiler-fuel bins. The house at the foot of this conveyer covers the crusher. To the left of the crusher house is seen the heavy and rigid framework supporting the shaking screens, designed to reduce the vibrations due to their operation.

As a further precaution against vibration, the frame is so built as to be entirely independent of any other part of the tippie. Not even a plank is allowed to be nailed to both structures, and as a result the slight rhythmic vibration caused by the screens is confined entirely to this frame.

In Fig. 1 is shown the opposite side of the tippie with its four loading tracks, with the sheave house directly above the shaft. It will be noted that there is plenty of head room between the top of the loaded car and the coal bins. In the background of this illustration some of the company's brick dwelling houses are seen.

In Figs. 1 and 2 a conspicuous feature is the sheave house over the shaft head-frame. This house is designed to facilitate the replacement of the head sheaves when the latter become worn or broken. It contains an I beam suspended over the center line of both sheaves and projecting beyond the line of the tippie house. A 4-ton trolley runs on this beam and is used in lowering worn sheaves to the ground and placing new ones. In Fig. 1 the spare sheave is seen leaning against the tippie immediately below the beam where it can be picked up and substituted for a worn or broken sheave in a few minutes, thus eliminating one possible cause of shut-down. The sheave house is large enough to store the spare in it, thus protecting it from the weather and adding to the convenience of replacement. The lower floor of the sheave house is reached, as shown in Fig. 1, from the tippie floor and from the ground by an open stair completely railed. The upper floor is reached from the lower floor from within by means of a steel ladder.

The tippie machinery is driven by three Westinghouse Junior

steam engines, and the empty-car transfer and cager on the tippie floor are each operated directly by steam cylinders.

An addition to the tippie is under construction, which will extend 80 feet to the left of Fig. 1 and will contain the repair shop for mine cars. The floor of this addition will be a continuation of the tippie floor, the empty car tracks being extended entirely through it. This arrangement is one that the company has used at other mines and found to be of great convenience. The addition will end in an abutment on the hillside supporting a level fill connecting with the main wagon road and furnishing a convenient means of access for supplies as well as an out-door yard adjacent to the shop.

This extension will be integral with the tippie proper, though erected after the completion of the latter as a separate contract. The steel framework is being fabricated and erected by the John Eichleay, Jr. Co., of Pittsburg, Pa. It is similar to that of the tippie, though not quite so heavy. There is but one floor level, though a stairway leads to the tippie floor on which is located the

cylinder operating the transfers. This floor has a clear area of 20 ft. \times 36 ft., which will be used for storage of miscellaneous supplies.

The shop is of oak planks, except the central portion, which is of reinforced concrete. Here are located the four power-blown forges for sharpening tools and general smithing. These are placed in a compact group about on the center line of the building. The forge blowers and all tools are driven by a line shaft supported at the center of the roof trusses and actuated by a small air-operated engine. The fol-

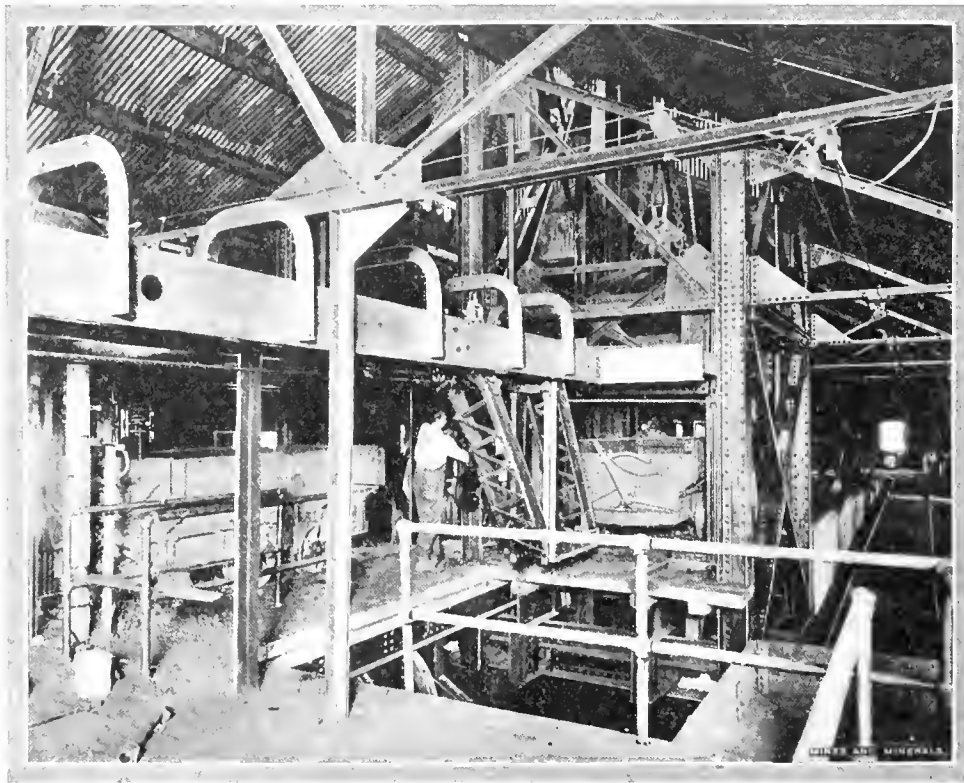

FIG. 3. CAGE LANDING

lowing tools will be installed: One Colloday 20-inch panel planer; one 12-inch power jointer with safety cylinder head; one 40-inch Colloday band saw; one Atlantic Works double-arbor sawing machine with iron tilting table; one 20-inch Brockford upright drill press; one Challenge iron-stand grinder with two 14-inch emery wheels; also several air-operated portable drills and boring tools.

Two 10-inch I beams are suspended from the roof trusses at about the third points in the span. On these run 2-ton naval type chain block trolleys for handling mine cars.

The empty car tracks of the tippie extend through the building on either side, the central area being clear for working space. Two turntables are provided for convenience in running the cars on and off the tracks. A cross-over dump with steel hopper, chute, and under-cut gate is also provided in this building for loading local domestic coal into wagons.

The level yard already mentioned affords a convenient place to store lumber and heavy parts, as well as providing easy access to the tippie for bulky materials to be lowered into the mine.

The principal duty of this shop will be to keep the mine cars in repair. These are of wooden construction and have a capacity of about 2½ tons. They were designed by the company and weigh about 2,800 pounds each, being heavily braced with steel.

The structural framework of the tippie proper is of solid, almost massive design; spans are long, and the design throughout aims at few members of large sections, rather than many lighter pieces. In addition to this, the main members, such as the columns, were arbitrarily increased in section over the stress requirements, in order to insure a long life to the structure.

The importance of this feature of the design has been amply proven in the experience of this and other mining companies during the last 20 years; a period which comprises the general use of steel in coal tippies. The design was begun May, 1910; the contract was let October, 1910; the first shop-detail drawings were received for approval January, 1911, and these drawings completed June, 1911. The tippie was ready for test operation in August, 1911.

In designing the steel framework, all loads and stresses were carefully calculated, though no attempt at great refinement was made, the aim being to insure sufficient strength and stiffness in all parts, rather than to discover the minimum safe load.

Particular attention was given to the design of details which would facilitate cleaning and painting, and eliminate so far as possible pockets which would allow the accumulation of coal dust. Although much has been written on the importance of providing for cleaning and painting, in the design of steel structures, few tippie designers seem to give it any thought, in spite of the fact that very little reflection is needed to make clear the fact that large por-

tions of ordinary structures, such as latticed struts and columns, receive practically no paint at all after the first shop coat, and consequently the useful life of the entire structure is greatly reduced. The fact that rusting is greatly augmented by accumulations of dust and dirt, which holds moisture against the steel, has long been recognized, and it is evident that sulphur compounds in coal dust make this effect greater in tippies than in bridges, etc. Recent experience has shown a graver danger threatening the structure from accumulations of coal dust adjacent to main members. The danger referred to is that of fire. Recent experiments on the explosibility of coal dust in mines have demonstrated that it is a combustible second only to gunpowder. It is not surprising then, that steel tippies are occasionally ruined by short hot fires fed almost entirely on coal dust, which ignites from some small blaze and spreads almost instantly over a large area. In such cases, the buckling and twisting of latticed columns occurs in a few minutes, and the tippie may be a complete wreck even though the

fire be extinguished before the floor planks have been charred half through.

In the Annabelle tippie all columns were of built I section (four angles and web) and the struts were of built I or double-channel section, according to position and connections. The former was used in bracing in the plane of the column webs and the latter the plane of the flanges. In the last-mentioned case, both angle diagonals and channel struts were tied with batten plates, and in the former, stitch rivets were used. No channels less than 8-inch depth were used and these were of section heavier than standard in order to avoid their webs. No metal of less than ¾-inch thickness was used.

Tippie structures are peculiarly subject to rust. A tippie over a shaft is placed in immediate contact with the mine air as it leaves the opening (the hoist shaft usually being upcast). This mine air is not only laden with the natural gases from the workings and

those produced by blasting, but also carries a high percentage of moisture. Where mines are naturally dry, moisture is artificially introduced into the ventilating current in order to keep down the dust. As this mine air is, during the greater part of the year, at a higher temperature than the outside air, the result is that moisture is condensed and deposited on the steel work. This moisture absorbs sulphuric acid from the fine coal dust flying about the tippie and from the oven smoke, where there are coke ovens, the result being intensive corrosion, particularly of the columns and struts immediately above the shaft. It has been necessary at certain mines to replace column sections in this part of the tippie within 5 years after their erection. Such cases were no doubt

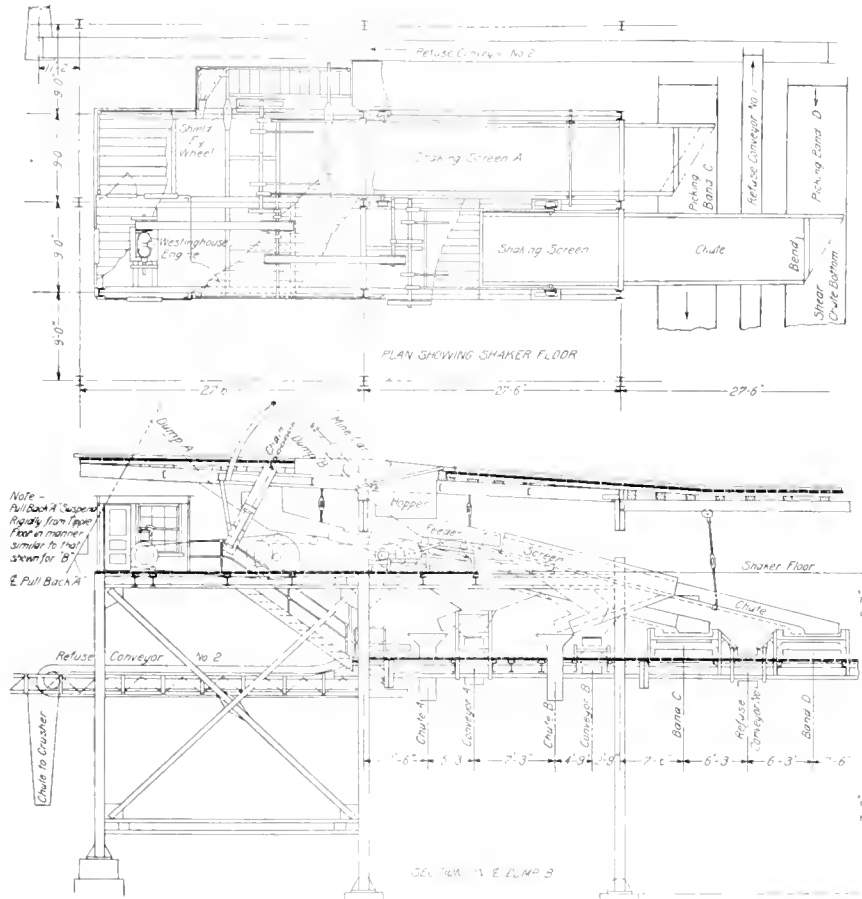

FIG 4. PLAN AND SECTION OF SCREENING FLOOR

aggravated by failure to properly clean and paint the structures, but it is always difficult to secure proper technical attention to structures built at mines. Certainly it is economy to provide excess steel in the design, as the cost of replacements to so complicated a structure is always much higher per pound than the original cost, and what is still more important, the structure is liable to be more or less out of commission during such repairs, and as a consequence the output of the entire operation is reduced. The use of pure-iron sheathing is also in line with this policy. The corrugated steel usually employed for this purpose, even though galvanized, has a very short life, and the expense of replacement is great. In this structure No. 18 gauge roofing and No. 20 gauge siding galvanized corrugated American ingot iron was used throughout.

In the design of this tippie especial attention was given to providing for the safety and convenience of the workmen. All gears and flywheels are provided with guards, easy stairs having ample

head room and complete railings afford communication to each floor, and all parts are accessible by means of railed platforms. Machinery located at or near the floor is railed off and all openings are similarly protected. The revolving screens are completely enclosed in dust-proof steel cases, which also include the discharge end of the conveyers delivering to them, the chutes conveying fine coal from the screens are also enclosed so that the usual clouds of dust are absent. Ample light, both natural and artificial, is provided.

All of the conveyers in this tippie are of the overlapping plate or pan type. This feature constitutes a departure in tippie design, as scraping conveyers are commonly used, especially for fine coal. However, the Four States Coal and Coke Co. adopted the pan type at additional expense in order to eliminate breakage of the coal. Another valuable feature is the duplication of parts. Practically the entire equipment is in duplicate. There are two dumps,

on the cage is pushed off by a steam-operated pusher of special design. In the same operation an empty car is substituted on the cage. The loaded car then gravitates under control of the dumper helper to one of two special cross-over dumps. Here the coal is dumped into a fixed hopper. The empty car then gravitates to a kickback, and thence to a point below and beside the shaft landing. From here it is elevated and traversed by a steam-operated transfer into position to be pushed on to the next cage.

The cages as well as all other parts of the structure and equipment were designed by the engineers of the coal company. They are of very heavy build and are provided with side plates extending to full height. These cages are equipped with the Lepley patent safety device as specified by the purchaser. This device consists of a steel wedge bearing against the side of each guide when in action. The wedges are brought into action by a powerful spring located above the center of the cage. The tension of

the hoisting rope normally holds this spring in compression, and any slackening of the rope allows the spring to expand. This action through suitable levers brings the wedges against the guides, when the weight of the cage acts to create a powerful pressure against the guide. This device is of a very reliable and efficient design, as shown in tests and actual service.

Semiautomatic car stops are provided on the cage, on the transfer, at the transfer pit, and at the bottom of the shaft. The latter, while not a part of the tippie, will be included in this description in order to fully explain the method of handling cars. This

apparatus was designed and installed by the Phillips Mine and Mill Supply Co. It consists essentially of two pairs of "horns" placed on the track. These horns are connected together by a system of levers which also connect to a rocker which is depressed by the cage in descending. The movement of this rocker causes the forward pair of horns to release one car, which gravitates to the cage. The same movement closes the rear pair of horns, retain-

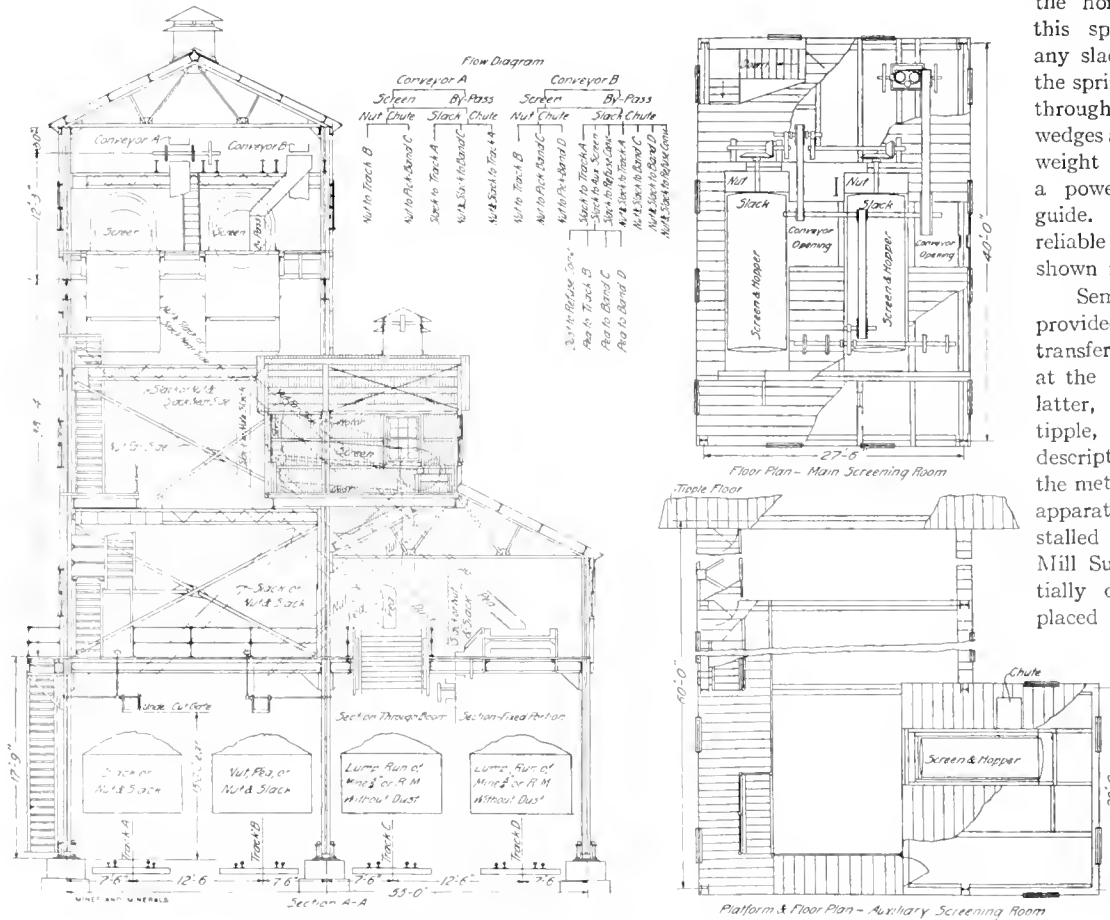

FIG. 5. PLAN, SECTIONS, AND FLOW SHEET OF TIPPLE, ANNABELLE MINE

two feeders, two shaking screens, two picking bands, two elevating fine-coal conveyers, two revolving screens. Thus, one-half of the tippie can be run entirely independent of the other half. In addition to this, the principal units can be by-passed. The conveyers are all of the same size and have head- and foot-shafts of the same diameter, so that chains, attachments, sprockets, and bearings are interchangeable. These parts, as well as all pulleys and gears, are of steel and are, as far as possible, duplicates of similar parts in use at other mines of the company, so that the number of spare parts carried is a minimum.

The structure was erected by a stiff-leg derrick with 80-foot steel boom, mounted on a wooden tower built in the angle between the principal wings of the tippie.

The head-frame supports cage guides which are continuous with those on the shaft. Between them, the cages are hoisted from the shaft bottom to the elevation of the tippie floor. Here they are caught on heavy cast-steel "landers." The loaded car

ing the next car. The rising of the cage causes a reversal of these movements, allowing all the cars to move forward one length, the car which was against the rear horns gravitating to the forward horns ready to move on to the cage when it descends again. The car stop on the cage consists of the tilting dog and the vertically moving stop. The latter is actuated by the levers, which extend to convenient points at each end of the cage. The car, in moving on to the cage, depresses the tilting dog with its chain-haul attachment. The latter then strikes the stop, bringing the car to rest at the center of the cage. The car is prevented from rebounding by the rising of the tilting dog. The stop is automatic except for the release, operated either by the dumper's helper or the transfer man.

The stop at the transfer pit is a simple stop which is normally held up between the rails by a counterweight and depressed by the transfer when it is down. It acts simply as a safety device to guard the pit when the transfer is up. A stop similar to the one on the

cage is provided on the transfer to retain the car. This stop, however, is automatically released at the top of the run.

The car transfers are of the usual type, consisting of two opposed incline cars running on tracks forming the sides of an isosceles triangle. The base of the triangle is occupied by a long steam cylinder. This cylinder has a piston with a rod at each end. These rods are connected to the transfers by ropes passing over sheaves at the angles of the triangle. The arrangement is such that one transfer elevates an empty car while the other is returning light. The pushers are of a design developed by the company's engineers. They consist essentially of two steel-frame carriages each traveling in the planes of the center line of one of the load tracks. They are suspended from overhead runways and connected to each other and to a steam cylinder by means of a wire rope, in such a manner that the travel of the piston traverses one carriage toward the cage and the other away from it at the

The lowering of the right-hand transfer has been accompanied by the rise of the left with an empty car ready for the left-hand cage, which will rise as the right is lowered, the cages and transfers operating in balance. The reversal of the pusher will push the left-hand car on to its cage, displacing the loaded car, and at the same time return the right-hand pusher to the rear, out of the way of the transfer and ready to push the right-hand car. This equipment is very simple and reliable in operation. It eliminates all hand tramping of the mine cars and insures safe handling at maximum capacity.

The Phillips cross-over dumps are extra heavy and are arranged with steam pullbacks. The dumps are operated in the usual way, the steam cylinder being used merely to return them to normal. The only modification made in the dumps to accommodate the pullback is the substitution of a shaft and bearings for the usual rockers, and the placing of this shaft about 8 inches to the rear of

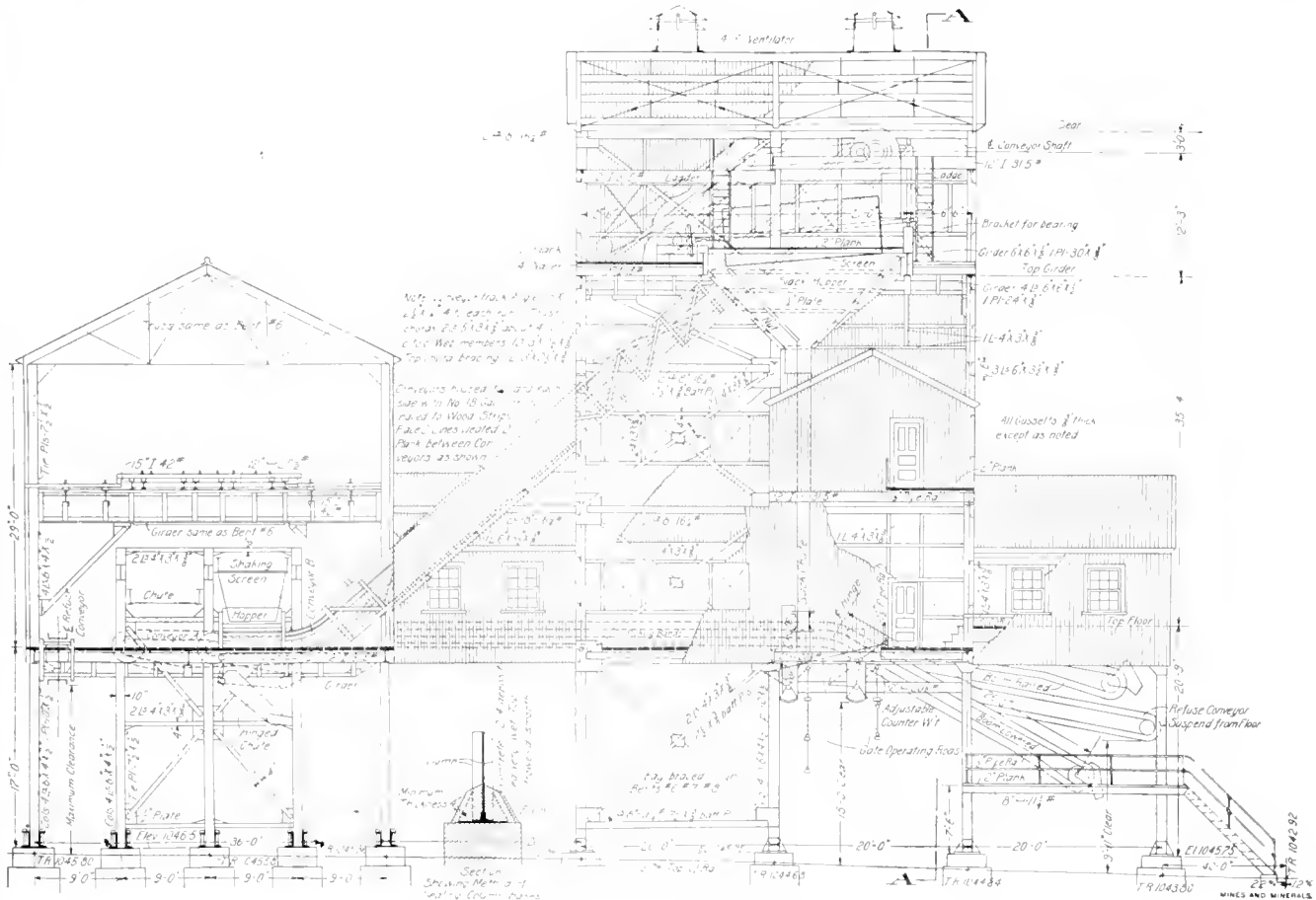

FIG. 6. SIDE ELEVATION OF HOISTING SHAFT TIPPIL

same time. The rope is led around sheaves arranged to give a 4 to 1 reduction of motion. The carriages have cast-iron bumpers on their lower ends. These are attached to spring drawbars and strike the car bumpers. The travel is sufficient to place the empty car on the cage at the same time displacing the loaded car.

The transfers and pushers are operated by a man conveniently placed between and close to the cages. This man also operates the car stop on the cage, the cage landers, and the signal to the hoist runner. He has an unobstructed view of all the parts under his control, as is evident in the photograph, Fig. 3. A cage has just been loaded with an empty car and is about to descend into the mine. The attendant is in the act of pulling the lever releasing the cage landers. The pusher which has just delivered the empty to the cage is still in its forward position, while the corresponding transfer car has been lowered and has received another empty which it has released from the automatic stop on the empty track.

the center of the car instead of about 3 inches, the usual distance for rockers.

The arrangement of the machinery of the Annabelle tippel at the hoisting shaft is shown in Fig. 5 in plan and section, also the flow sheet. Fig. 6 is a side elevation of the hoisting-shaft tippel showing details of the chutes and screen arrangements. Fig. 4 shows the plan and section of the screening floor with chutes and picking bands.

The coal is received from the cars by steel hoppers having reciprocating plates in the bottom. These reciprocating plates extend beyond the hoppers, so that at each stroke a certain amount of coal is delivered to the shaking screens. The amount of the discharge is regulated both by adjusting the length of stroke and by changing the depth of coal on the plate. This is accomplished by means of a vertical gate in the hopper.

Each shaking screen is driven by adjustable eccentrics mounted on the same shaft as those driving the corresponding feeder.

The shafts are driven through transmission belts by a 7" x 9" Wainwright Junior steam engine. The screen plates are in three sections and extra plates are provided, so that by changing the plates of several sizes of coal can be obtained. One set of plates has oval perforations 1 1/4 in. x 2 1/2 in.; another set has 1 1/2" x 3" and 2 1/2" x 5" perforations, respectively. The fine coal which passes through the screen is collected in a shaking hopper which feeds it at a uniform rate to the conveyers leading to the rescreening tower. The large coal which passes over the screen is fed by a shaking chute on to the picking band. Figs. 7, 8, and 12 show the shaking screens discharging on to the picking bands. They also show the drive end of the picking bands and the refuse conveyer. In Fig. 7 are seen the columns and girders supporting the screens as well as the end of one of the fine-coal conveyers, and the railed passage and stairs leading to the driving mechanism. Veil plates are also provided so that run-of-mine coal can be slid directly upon the picking bands.

The two picking bands are each located immediately over the corresponding loading track. They are 6 feet in width and have a clear length for picking of 45 feet. They are formed of overlapping steel plates supported on flanged rollers, running on steel wearing strips supported on angle frames. The bands are driven from the receiving end, and have adjustable take-ups at the discharge end. They move at the rate of 40 feet per minute. The picking is done by men who walk on the bands, as shown in Fig. 9. This method has been found to be much superior to having the men stationed along the sides of the bands, as they are able to follow the coal if necessary to care for an area having an unusual amount of impurity. They are also better able to reach all parts of the bands and are not likely to shirk, as they have to "keep moving." The refuse conveyer runs at the bottom of a trough of steel plates which is triangular in section, the sides extending to the top of the picking bands. This is shown in Fig. 8, which also shows the refuse conveyer rising to discharge on to the second refuse conveyer leading to the boiler house. This view also shows the railings placed at each end to protect the pickers from going too far.

Twenty-six feet of the length of each picking band at the discharge end is free to move in a vertical plane about a trunnion in the frame. The free end is supported by ropes and sheaves attached to the drum of an electric hoist, and carries the end sprocket and take-ups, the picking bands of course passing over these sprockets. To this end is attached a short chute which concentrates the flow of coal to a width of 30 inches, and a second chute is placed below this to catch any coal that may cling to the plates as they turn over the sprockets. Chains limit the downward travel, and friction drives prevent hoisting too high. The object of these booms is to eliminate breakage by lowering the end of the band nearly to the bottom of the car in beginning to load.

Angles on the bands prevent the coal sliding. The booms are controlled from a point at the end of the picking room between the bands, where the operator has an unobstructed view of the end of the bands and the car trimmers through large railed openings in the floor. In addition to the controllers, this man also has convenient levers operating the friction clutches driving the picking bands and electric signals to the dumps. The dumper has in easy reach a lever controlling the clutch on the shaft driving the feeders and the shakers. When a railroad car has been placed in position to begin loading, the crane man lowers the boom until the discharge chute is practically on the bottom of the car. He then

starts the picking bands, signals to the dumper if necessary, and as the car gradually fills up, he lifts the boom little by little until the end of the car is loaded to full height. The car is then slowly dropped down the grade until it is full, when the loader stops the travel of the picking band and raises the boom high enough to clear the car while the trimmers drop down another car. These booms are shown in use in Figs. 10 and 11. Fig. 11 also shows on the right the refuse conveyer, which descends to the height of the top of the car in order that the trimmers may place on it any refuse which may escape the pickers and appear on the car. In Fig. 10, on the tippel column to the right, is also seen the car retarder manufactured by the Fairmont Mining Machinery Co. This

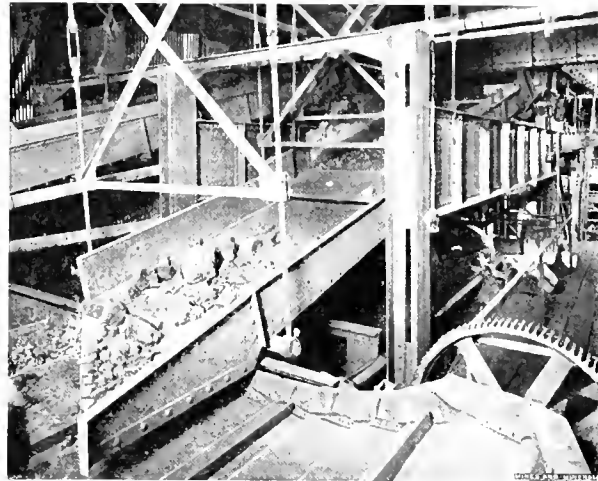

FIG. 7. SCREEN DISCHARGING TO PICKING BAND



FIG. 8. SHAKING SCREEN DISCHARGING ON TO PICKING BAND



FIG. 9. PICKING BAND AND WASTE CONVEYER

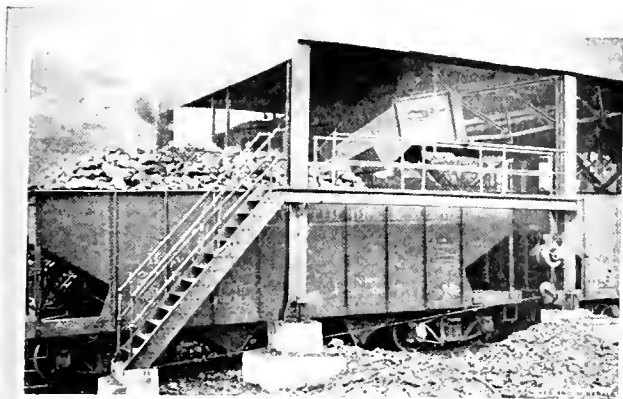

FIG. 10. CAR BEING LOADED

consists of a drum on which is wound a wire rope with a hook for attaching to the car. A hand brake controls the speed of the car, or stops it as required. The brake is operated by the crackerman from his position in the picking room. The track grade here is 2 per cent., so that the motion of the car is always positive and under control. Mine run and various mixed grades are loaded from these booms by means of the closed chutes shown in Fig. 12. This arrangement insures much better preparation than would be possible were the fine coal all allowed to pass on to the picking bands with the lump, as the former would obscure much of the impurity. Veil plates are, however, provided on the shakers as an emergency device. The chutes are so arranged that the nut and slack can be diverted to either picking band, either fine coal track, the refuse conveyer, or the auxiliary screen. The lines operating the gates or flies which divert the coal are seen hanging down and terminating in convenient handles. The small winches which regulate the slope of the terminal chutes on the booms are seen in this view. Branches of the chutes not visible lead to the two fine-coal loading tracks. They are fitted with undercut gates so that the flow can be cut off when shifting cars. These are operated by levers so placed that the gates can be opened or closed either from the car, trimmer's platform, or the floor above. There are large areas left unfloored above the tracks so that the process of loading is in full view of the tippie operatives. These and all other openings are completely railed. At the point where the fine-coal elevators receive their load under the shaking screens, are arranged by-passes by means of which nut and slack can be loaded directly into cars, without being elevated to the rescreening tower.

The two main revolving screens are each 6 feet in diameter and 16 feet long. They are hexagonal in shape and are covered with wire cloth of $\frac{3}{4}$ -inch square mesh. The screens and the conveyers which feed them are driven by a 10" x 9" Westinghouse Junior engine. Each unit is controlled by a friction clutch with convenient operating lever. The screens are enclosed in dust-proof steel cases. These covers also enclose the elevators above the level of the screen floor. The auxiliary screen is of similar construction, and is similarly housed. It is 4 feet in diameter, 12 feet

long, covered with $\frac{1}{2}$ -inch mesh cloth, and is driven by a 10-horsepower electric motor. The principal purpose of this screen is to provide boiler fuel to supplement the picked refuse. The practice of the company at all of its mines is to burn for power purposes only the lowest grades of coal. The fuel will be supplied first by the bone coal from the picking bands; as this is all burned, the men are instructed to throw off good coal rather than to allow any doubtful pieces to pass, thus insuring thorough cleaning. Even their liberality is, however, not sufficient to provide the necessary fuel, and the bone is supplemented with the dust from the auxiliary screen. The removal of this dust has the effect of improving the grade of fine coal shipped. When it becomes necessary to further increase the fuel supply, it will be done by simply opening a gate, allowing the slack to flow on to the refuse conveyer, and thence to the boilers. If necessary, even the nut can be used for this purpose. This tippie is believed to

represent the best practice of today in this class of structures, and for this kind of coal. In the preparation of high-grade coal for market, it is believed to excel anything now in operation.

It is claimed that the Pittsburg coal bed in the Fairmont district possesses qualities which the same coal bed does not possess in other parts of the state. In fact, as a gas producer this coal ranks with the best coal in the Pittsburg, Pa., district, it having the following analysis: Moisture, 1.17; volatile matter, 34.30; fixed carbon, 57.88; ash, 6.65; and sulphur, .82. The number of British thermal units in this coal is 14,100.

Acknowledgment is made to the Jeffrey Mfg. Co., Columbus, Ohio, for the excellent photographs used to illustrate this article, and to the officers of the Four States Coal and Coke Co., David G. Jones, president, E. F. Miller, vice-president, Thomas P. Jones, treasurer, A. C. Beeson, chief engineer, and E. C. Auld, division engineer at Annabelle, for the use of the data accompanying this article.

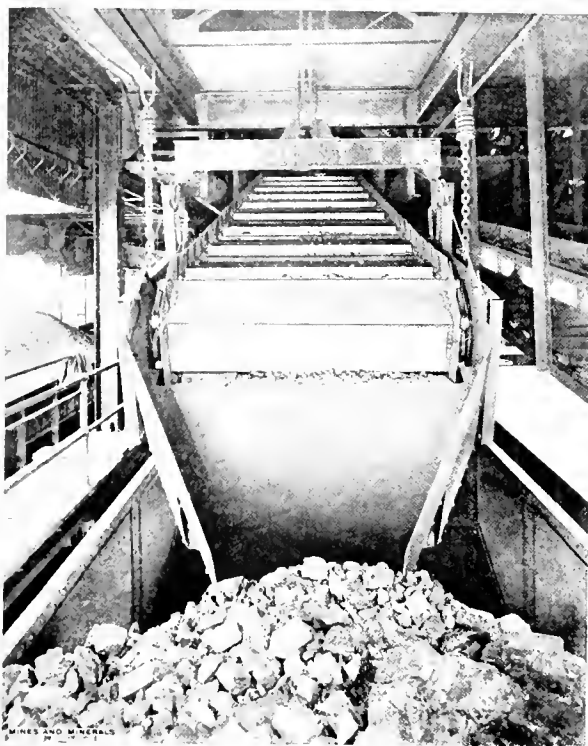

FIG. 11. LOADING INTO CAR

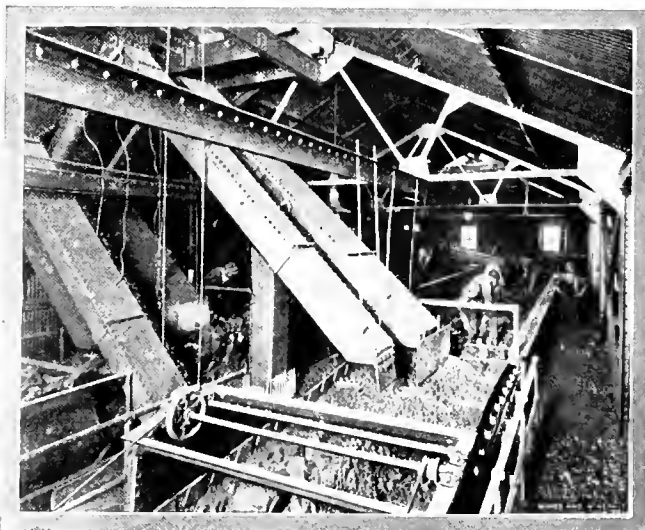

FIG. 12. CLOSED CHUTES DISCHARGING ON PICKING BAND

Bottom Creek Mine Explosion

Conditions Existing at the Mine at the Time of the Explosion When 18 Men Were Killed

On November 18, at 11 A. M., an explosion occurred in the Bottom Creek Coal and Coke Co.'s mine No. 1 at Vivian, McDowell County, W. Va. While the explosion was local and was not felt in some parts of the mine, nevertheless the conditions were such as to cause the death of 18 men, all of whose lives could have been saved had a little precaution been taken prior to the accident by the engineers who lost their lives.

The Bottom Creek mine was opened in 1892 by the late William Spencer, of Pottsville, Pa., and it has been worked continuously since that time. The old workings are quite extensive, although within the last four or five years particular attention has been paid to pillar robbing and entry driving for development rather than to opening new rooms. In some of the new entries a few rooms have been turned and worked more for exploration purposes than for the coal obtained. It was in one of these abandoned rooms that a pocket of gas was ignited that caused the disaster. The Bottom Creek mining village connected with the operation is shown in Fig. 1. The tipples faces Elkhorn Creek, and almost at right angles

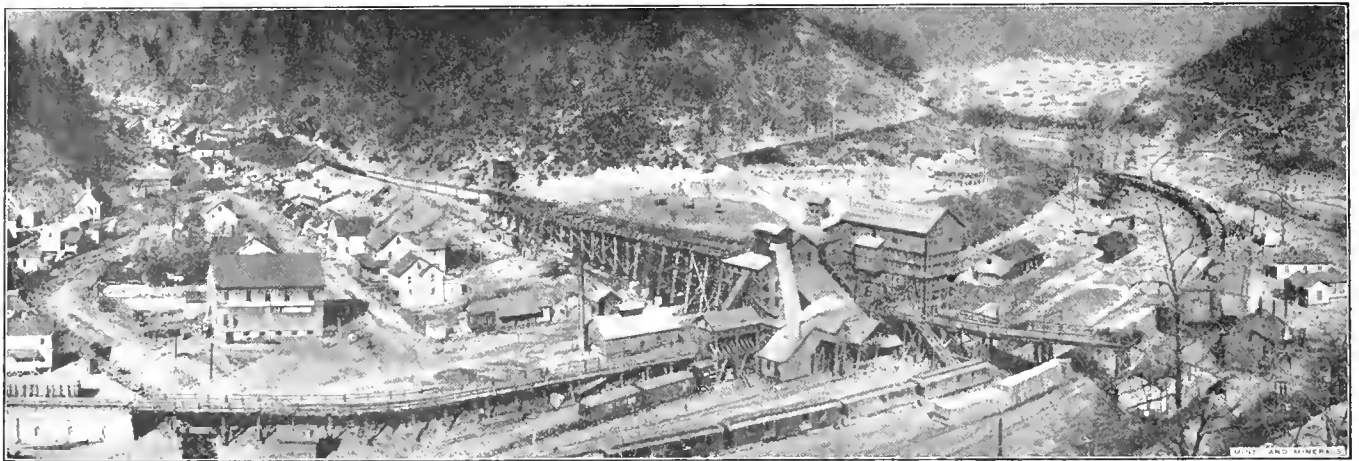

FIG. 1. SURFACE ARRANGEMENTS AT BOTTOM CREEK MINE, W. VA.

to Elkhorn there is a gulch down through which a small stream termed Bottom Creek flows. The railroad station, Vivian, is 28 miles west of Bluefield on the Norfolk & Western Railroad. At this place the No. 3 Pocahontas coal bed crops about 30 feet above Elkhorn Creek, but by going up Bottom Creek a short distance it is possible to strike the coal bed at a level which furnishes a grade suitable for hauling the mine cars direct from the mine to the dump on the tipples floor. The coal at this mine averages 5 feet 9 inches thick with a thin bone parting from 1 to 2 inches thick at from 12 to 15 inches below the roof. Above the coal is a crack possibly one-eighth of an inch thick which contains mother coal, and above this there is a draw slate from 8 to 14 inches thick capped by two layers of black slate which are from 1 to 2 feet in thickness. Owing to the mother coal parting, the draw slate does not cling to the coal and does not come down when the coal is blasted. However it is taken down in entries and also in rooms if in the judgment of the mine foreman some one is likely to be injured by its falling.

The black slate sometimes falls with the draw slate, but generally most of it remains up until the robbing begins. In main entries the black slate is always taken down to prevent accidents and this leaves a hard sandstone roof. Directly under the coal is a hard fireclay, possibly averaging 3 feet in thickness. The mine is worked on the double-entry system, rooms being 20 feet wide and pillars 60 feet wide. The entries are driven 12 feet wide, airways 14 to

16 feet wide and breakthroughs are driven every 80 feet to comply with the West Virginia mine law.

The Bottom Creek mine being opened practically at water level was the first to show gas in the Pocahontas field, and for a number of years the small quantity of gas at this mine has necessitated the employment of a fire boss, whose duty it has been to watch the ventilation, and examine the working places every morning prior to the miners going to work. Air has always been supplied in sufficient quantities to keep the working places free from explosive mixture of gas, and it is seldom that any is detected except in holes where a kettle bottom has fallen from the roof or in rooms driven on a slight rise where the air-current was not active. Of course, in abandoned rooms where a roof fall occurs gas is apt to accumulate in the hole, and the air-current not being able to reach it and sweep it out the diffusion takes place slowly. To guard against any danger from this source the company placed warnings at the entrance to each room, and to guard against any large accumulation of explosive mixture in these old workings, the mine inspector of the district insisted upon their being examined every week.

Ventilation is supplied to this mine by a 16-foot diameter blowing fan driven by a steam engine. In order to dampen the air-current and prevent it from absorbing moisture from the coal the fan engine was allowed to exhaust into the intakes. This arrangement for moistening the mine air has been in operation over two years,

during which time it has proved satisfactory, although it is claimed that the moisture has a tendency to make the slate fall sooner than it otherwise would. However in this mine the roof is bad and the men are always watchful.

On Monday, November 20, two days after the accident, hygrometer readings were made by the mine inspector, and these were as follows:

Dry	Wet	Place	
34	31	Outside	Damp
52	51	Return and drift mouth	Wet
65	64½	Main entry, No. 8 haulway	Wet
60	60	Main entry	Wet
61	60	No. 13 entry	Damp
62½	61½	No. 12 entry	Damp
63	62	Rooms No. 12 entry	Damp
65	63½	No. 9 pillars	Some dust

Before the air-current reaches the active working places it has to travel about 5,000 feet, at which point it is split to pass through the different sections of the mine. This drag on the air-current does not interfere with there being plenty of fresh air in circulation. For example, three days prior to the explosion, measurements were taken: In No. 10 entry at the last breakthrough 7,000 cubic feet of air was passing, in No. 11 entry at the last breakthrough 15,000 cubic feet of air was passing, and it is presumed that this same quan-

tivity of air was passing at the time the explosion occurred. As an executive force at the mine there is a mine boss, fire boss, night boss, and a number of entry bosses who have charge of one or more of the entries being driven. The night boss has charge of the night shift men who are engaged in handling slate, laying tracks, or performing any other necessary duty if the occasion demands. Part of the night boss' duty is to assist the fire boss in making the morning's round of inspection. Each boss after consultation examines different parts of the mine for gas, roof troubles, and to see that the air is moving in the proper direction.

At the time of the accident the mine boss was away and his place was filled by the fire boss, who with his deputy made the usual inspections on the morning of the explosion and found the ventilation and mine in good condition. Earlier in the week they inspected the old workings, as was their custom. At about 11 A. M., November 18, the boss of No. 11 entry was standing near door *a* Fig. 2, when he was knocked down by a gust of air. The door was blown open but not damaged and as soon as the entry boss could rise he ran for his safety lamp and sent word to the men in other parts to leave the mine. The concussion preceding the explosion damaged a patent door *b* on entry No. 12. The fire boss who was in this vicinity immediately had this door repaired and with a few others attempted to go into No. 11 entry, which was the return airway. It is probable that if this door *b* had not been damaged the comparatively small amount of afterdamp which was formed on the return entry No. 11 would not have proved so fatal.

It will be noticed that most of the bodies were found between room No. 7 and room No. 8, a distance of about 300 feet. This rescue force with the fire boss succeeded in bringing out 6 men from No. 11 entry, three of them uninjured. Word of the accident was sent to the outside and men near the mines responded quickly.

The explosion was scarcely felt in any other part of the mine, and beyond the door *b* no damage was done except there was a considerable roof fall due to the concussion. The explosion was probably started at *c* in room No. 7 by the open lights of two engineers igniting a pocket of gas. The flame traveled against the fresh air about 300 feet to *d* where there was an opportunity for the air in room 8 and the breakthrough opposite to rush into the vacuum caused by the compression wave. There being little fuel for the flame to feed on in this direction, naturally the air rushing into the vacuum cooled whatever flame there was at the point *d*. The flame traveled with the air about 800 feet to *e*, where there was an opportunity for the air to rush from rooms 4, 5, and 3 and from the breakthrough, into the vacuum caused by the compression wave in this direction, which, of course, cooled the flame and put it out. Naturally there was more dust in the return and in all probability more fuel for the flame, for it attained sufficient velocity to pass rooms 5 and 4, although it is possible that the expansion of the air from these rooms was instrumental in cooling the flame to such an extent it went out at *e*.

A rescuing party was organized and proceeded up the intake of No. 11 entries repairing the stoppings by the use of brattice cloth until the face of the entry was reached. Working from this point the rescue party brought out 16 bodies. The two remaining bodies were recovered from under a fall of slate in room No. 7 by another

party which went in later for them. It was found that few of these men were burned, the others having suffocated or been struck down with falling slate. The location where the bodies were found is shown by dots on Fig. 2. One man working at about 80 feet from the face of the entry escaped by making his way down the return on No. 12 until he met the first rescue party. Two men working at the face of rooms 4 and 5 got out of their predicament without more than a scratch by running to the first diagonal. Three others were taken out alive and are in a fair way to recovery. Among those who were caught in the accident five were members of the engineering corps of the Crozer Land Association, and it was found that their measuring tape was stretched out in room No. 7, where two of the corps were found dead at *e*, 250 feet from the entry, their bodies being badly burned, and lying under a fall of slate. The appearance of the entry and of the bodies of the victims, and the fact that the explosion was only local, led those who examined the place to the conclusion that a pocket of gas was ignited in room No. 7 by an open lamp in the possession of one of the engineering corps. This was also the verdict of the coroner's jury. The engineering corps of the Crozer Land Co. were making their annual survey of the various mines of this company. No other mine on this company's land has gas, and it is presumed that the engineers did not appreciate the danger into which they were entering at this mine.

These men had been notified some time previous to the accident to consult with the mine boss or fire boss relative to the places they were to visit and measure. The Bottom Creek Co.'s own engineers always do this before going into the mine, and it is customary where gas is present for all engineering corps to take the fire boss along with them; the most charitable construction to put on the mistake therefore is that the young men, not being ac-

customed to gas, did not appreciate the danger in this mine and so neglected to take proper precautions for their own and others safety. On this particular occasion the entry boss did not know the engineering corps were in his entry. The fire boss had seen them for a moment as they got off the motor but did not know where they were going. It is the unanimous opinion of the mine inspectors who visited the mine after the accident that had it not been for the good condition of the mine, especially in respect to the amount of moisture in the air, the quantity of air, and the way in which it was split, that the entire mine might have been affected, and the total force of 125 men who were at work might have lost their lives.

The inspectors were also enthusiastic over the results of this steam jet system as applied to the intake air at this mine. So little damage was done to the mine that about 10 or 12 men would be able to clean it up in a day, and in those parts unaffected work might have continued, but the Department of Mines and the company desired that a thorough investigation be made before work was resumed.

It is presumed that those killed were outside the zone of explosion, working in rooms 9 and 10 and beyond; that after it occurred they rushed down No. 11 entry into the afterdamp and were either overcome or killed by falls of slate.

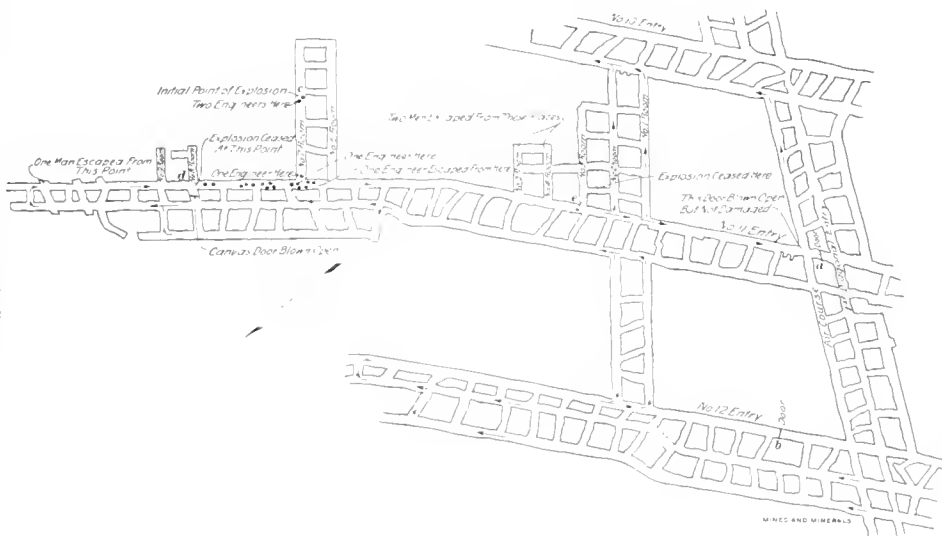

FIG. 2. PLAN OF NO. 1 MINE, BOTTOM CREEK COAL AND COKE CO.

First-Aid Work and First-Aid Contests

The Value of Competition in Stimulating Interest, and the Importance of Organization and Correct Judging

By E. D. Burkhard, M. D., and Samuel Dean, M. I. M. E.

The subject of first aid to the injured first took concrete form in Great Britain, about 1877, coincident with the organizing of St. John's Ambulance Association, and it has grown in latitude and efficiency ever since. In this country the first mine corps was organized in December, 1899, by Dr. M. J. Shields, at Jermyn, Lackawanna County, Pa., and within the past two years the United States Government, through the Bureau of Mines, has taken cognizance of the good work by providing for teaching and conducting it as part of the office of those in charge of the rescue cars. Indeed, the officials of the Bureau of Mines are worthy of being complimented on the good work they have done and are doing in conjunction with the coal mine operators, their success in stimulating interest in first aid being but one of their many laudable efforts.

It is not, and never has been, advocated as a substitute for prompt surgical attention, but as the term implies, it is rational temporary care of the patient until he can receive proper treatment. By such intelligent care and management the injured person is to be spared more or less unnecessary suffering and damage as well as loss of time; unnecessary suffering from improper manipulation and awkward handling; unnecessary damage the result of introduction of sepsis (blood poisoning), greater laceration of tissues, loss of blood, or increase of shock; unnecessary loss of time for repair of the increased damage and complications. The matter is of particular interest to men in the mines, where very severe injuries are received so far from the surface and far from a doctor's reach, and it is strange that the work which, for purely selfish reasons if none other, is of such direct personal interest to all men who go under ground, should receive so little attention from them. Undoubtedly one of the greatest problems is how to cultivate and maintain the personal interest in it.

Rivalry or competition may be made to furnish the desired stimulus and to that end we are having "contests" for prizes, medals, cups, etc. True, the public contests are very good as demonstrating methods, equipment, etc., but the essential benefit is only to the active members of the respective teams, while we need some way to get and hold the real interest of every man in and about the mine. Be it remembered that the work as exemplified in the practice room or on the exhibition ground is equally adapted to actual conditions two or three miles underground, and all men should know the what, how, and when to do.

A large number of teams working in a first-aid contest is no doubt a spectacular sight and arouses public interest; but first aid in itself is not spectacular, and the ultimate good of its aims will be defeated if competing teams are given credit for "grand stand displays" during the competition. In the contest at Trinidad, Colo., recently, seventeen teams were lined up and the winners of the first prize stood conspicuously alone for "originality." That originality consisting of the use of portions of the injured man's clothing instead of the regulation triangular or roller bandages for the dressing of his injuries, and the use of an impromptu stretcher of mine drills and miner's belt construction. During the transportation part of the events the winning team received the applause of the grand stand for its pseudo military manner of marching—a method not objectionable to the imitation patient, but which might be seriously detrimental to an actual patient under similar conditions; and the further fact that the members of that team wore dirty pit clothes and sported blackened faces emphasized the value of "originality" in that particular contest. The argument appears to have been that the winning team gave an exhibition of "first aid" resembling actual conditions in the mines today—that is, we are to infer that modern mines are not supplied with proper first-aid materials in the underground workings. Just here we beg leave to entirely disagree. An

exhibition of first aid should illustrate conditions and methods as they ought to be—not as they are, or rather are supposed to be.

Stretchers and boxes containing proper first-aid materials should be, and at many collieries are, located at different points in the mine within easy reach of the various workings, so that in case of accident any one familiar with first-aid methods would have the equipment to make use of his knowledge and skill to the advantage of all concerned. Unquestionably, an injured man would be much more comfortable and less liable to further injury when being transported on a regulation stretcher than on any kind of an impromptu affair. Again, you are courting dire after results when you bind up a bleeding wound with part or parts of dirty pit clothes, or anything else except the aseptic materials in a sterilized "first-aid package." Any open wound is serious enough, but its dangers are multiplied many times with the introduction of septic material from any source. Fortunately the rocks and coal in a mine are practically sterile and such dirt in the wound only acts as a mechanical irritant until removed under favorable conditions by a competent surgeon.

Splints of an average size for all limbs, and proper padding for them should be provided in addition to regulation sealed first-aid packages, and a good supply of blankets should be easily available. Of course it is important that these should be kept dry—if that is possible in some of our highly humidified mines. The real value of such equipment is acknowledged by common consent, therefore it is farcical to give public displays without using ideal materials.

At this early period it is probably unreasonable to hope to satisfy everybody connected with a first-aid contest, but the adoption of a code and the selection of competent judges will go far toward solving the difficulties. The organization of a contest being a matter of considerable importance, we venture to make some suggestions, hoping they will lead to the adoption of some standard rules and regulations.

Judging.—Coal mine and railroad surgeons are no doubt best qualified to judge such contests, but unless they are far removed from any possible affiliation or association with any of the contestants, we are quite certain to come in contact with the "after-damp" of the disappointed competitors; and if we are not able to eliminate the judge difficulty, it will be far better for the cause to abandon competitions. Competent judges are scarce, and in nearly every contest there will be many more teams than judges, and as first-aid work is not like mathematics, to be decided by the "end result," it is plain that the work itself must be watched with a critical eye. The imitation patient will not suffer from awkward manipulation or slips in asepsis that might be disastrous to the actual patient, although the final dressings might appear to be identical.

Ordinarily, one pair of eyes might be able to observe two teams working at the same time, but it is ridiculous to suppose that any one man could do justice to half a dozen or more teams scattered around and all working at the same time. Our remedy can best be explained by using a concrete example: Let us suppose we have to do with a list of 18 entries and three judges; to reach a fair decision, some sort of elimination process is necessary. Let the contestants be divided into preliminary squads of six teams each, being two teams for each judge in each event, and give the judge authority to halt, temporarily, the work of either team. In the first event let *A* judge teams 1 and 2; *B*, 3 and 4; *C*, 5 and 6; for the second and subsequent events they could progress one station each time, so that in three events each judge would have seen the work of each team and if six events, he would see each team twice. Then average the scores and eliminate the four low-scoring teams. In precisely the same manner, work out the second and third preliminary squads and in the end we will have a fourth squad comprising the two high-scoring teams of each of the preliminaries. This final squad could be worked out in the same manner as the preliminaries, using an elimination process again, if time permits, or have enough events to obtain a fair average of the ability of each team.

Selection of Events.—Before the contest, prepare cards of uniform size, shape, and quality, on each of which is written the details

of one event. Let there be a sufficient number, and if desired, they may be arranged in separate boxes for one-man, two-men, three-men, or full-team events. When a squad is ready to begin work, let a disinterested party draw one or more cards from each of the several boxes, as may be agreed upon, thus naming the events for that particular squad; when finished, return the cards to their respective boxes and repeat the operation for each succeeding squad. In this way, the same event might come out for other squads or there may be no two alike. The same method could be used all the way through, or a fixed and more elaborate program devised for the final trial.

Scoring.—The discount method of scoring has all in its favor and we suggest the following table of rules and discounts:

DISCOUNTS	
Each team starts with a score of 100 and to be penalized as follows:	<i>Per Cent.</i>
For not doing most important thing first	5
For failure to be aseptic	5
For loose splint	5
For loose bandage	5
For loose or granny knot	5
For lack of neatness	5
For wrong artificial respiration	5
For Captain's failure to properly command men	5
For not stopping bleeding	10
For not treating shock	15
For awkward or improper handling of patient either on the stretcher	20
For unfairness by hints, suggestions or any other means	15

The above-mentioned penalties are absolute, and judges are not to increase or decrease them.

In the preliminaries the judges are not to compute scores or make comparisons until all the teams have worked.

Time is Not to Be Considered.—We believe the placing of time limit on an event, or the consideration of time in any way is unwise, as tending to sacrifice care and efficiency for useless speed. If anything in first aid is worth doing at all, it is worth doing well. There are probably two conditions in which speed (not haste) is of importance, the application of tourniquet for spurting hemorrhage and the treatment of shock. Of course there are conditions in connection with rescue work where time counts, but in first aid we are dealing with surgical conditions.

Working along these, or similar lines, the first-aid contest can be of inestimable value to the cause, while the present methods, or at least such as were demonstrated at the Trinidad meeting, will prove a boomerang, doing inestimable damage to it. The "contest" must not be considered an end, but only a means to an end; to be useful it must not become commonplace; therefore, large or public contests should not occur more frequent than once, or possibly twice a year. But the interest in the work must be maintained every day in the year, so there will be plenty of opportunity for the exercise of originality and invention, and for enthusiasm in that direction.

One very commendable plan is the giving of medals or similar rewards for meritorious services under actual conditions. Thus, if a man is seriously injured in or about the mines and has been properly and well cared for by one of his fellows, the satisfaction of having done a humane deed would be reward enough for any thinking man, but the judicious display of a medal or other mark cannot but make it more impressive—especially on his fellow workers.

The medal might be something on the order of the Red Cross with name of recipient, date, and place engraved on it. It should only be given for truly meritorious services, in cases of unquestionable seriousness, according to rules and regulations which should be very carefully worked out; and if presented personally by the president or other important officer of the company it would add still more to its worth.

In conclusion, the writers fully realize that they have not exhausted the subject, nor do they anticipate that their views will meet with universal approval; therefore, they invite criticism and suggestions freely, for the real value of this article may prove to be not what it contains so much as what it may develop by discussion.

Use of Oxygen Helmet in High Temperatures

By H. H. Sanderson*

During the latter part of August a test was made with oxygen rescue apparatus at Virginia City, Nev., which will, no doubt, prove of considerable interest to mining men, especially to those that have similar conditions to contend with.

The test was made at the Ward shaft, which is operated by the Ward Shaft Pumping Association, being worked exclusively for drainage purposes. The shaft is at present about 2,500 feet deep with stations at various levels.

Nearly every one familiar with the mines in this district knows of the excessive heat encountered, especially at the lower levels, and it was the intention of the writer to test the apparatus under the most unfavorable conditions and ascertain if it were possible to wear the helmet in the very high heat.

The Draeger 1910-1911 two-hour helmet type of apparatus was used. It was decided to make the test on the 2,450-foot level and all air was shut off from this level on the night prior to the test. There being some doubt among the mining men as to the strength of the oxygen cylinder, one was charged to 175 atmospheres pressure, which is 25 atmospheres in excess of the regular charge, and placed in the water at the face of the 2,450-foot level, the water registering 165 degrees of temperature. This cylinder remained in the water for over 2 hours without any evidence of change. After assurance of safety from this source, four men, J. D. Moore, superintendent; H. R. Norsworthy, engineer; Ed. Ryan, state mine inspector; and H. H. Sanderson, were lowered to the 2,475-foot level. The men then put on the apparatus and were hoisted to the 2,450-foot level and all men went to the face of the drift, about 300 feet from the shaft. The temperature was about 134 degrees in the drift. On nearing the shaft on the return trip, some of the party felt that the apparatus was not working properly and all were again lowered to the 2,475-foot level. Here the men were cooled off by means of a spray of water coming direct from the surface, and the apparatus examined.

Prior to entering the mine the helmets had been used on the surface for nearly an hour's time in drilling men in a cave filled with sulphur fumes and it was now decided that the cause for the men's discomfort was due to this fact, as the air regenerators were not fresh when the test began. It was therefore decided to make a second try-out and the party again made preparations to descend the shaft. The oxygen cylinders were recharged and the new air regenerators placed in all apparatus. The helmets were put on before leaving the surface and the men lowered direct to the 2,450-foot level. Here it was found that the heat had increased to about 145 degrees. All went to the drift face and remained on the level about 20 minutes without the least discomfort from the helmet and all of the party agreed, that if necessary, this time could have been doubled. While the excessive heat could be felt very plainly on the body and hands, the face and head were kept cool, this being especially noticeable when the helmets were removed where the temperature of the surrounding air was about 100 degrees.

Members of the party wore very heavy woolen suits and heavy canvas gloves. On removing the gloves it was found to be impossible to bear the hand on any of the metal parts of the helmet or apparatus, and the water and rock were too hot to touch.

The test demonstrated two things: First, that in case of fire or bad air in any of the mines in this district it would be possible to enter the mine and work with the apparatus even though the heat was very great. Second, that while working under such conditions, new air regenerators should be used, and if possible changed every 30 or 45 minutes. The length of life of these regenerators could be lengthened by taking an extra one into the mine and exchanging them about every 15 minutes.

*Mining Engineer, Trinidad, Colo.

Track Arrangement for Shaft Bottoms

Four Plans and Their Respective Advantages for Handling Cars at Foot of Shafts

By Oscar Carltidge*

While a great deal of thought and attention has been given to the development of entries and chambers in mines for the practical and economical production of coal, comparatively little has been attempted toward improving the handling of loaded and empty cars at the bottom of the shaft. At present two systems are in general use—one is to cage coal from both sides of the shaft, the empties being run on what is termed the empty track which parallels the loaded one, as shown in Fig. 1; and the other is to cage coal from one side only, the loaded cars bumping the empty cars off the cage where, by a switchback, they are run on to the empty tracks on either side of the shaft, as shown in Fig. 2.

Fig. 1 is the oldest system and the one most in use today. Its disadvantages are that where any considerable tonnage is to be hoisted it requires a large force of men to cage the coal and drag the empties off the cage. Two tracks also require the entries to be at least 16 feet wide, which means that they must be timbered if the roof is tender, and as it will require 200 feet of double track on both sides this is no inconsiderable initial item, and it will have to be renewed at frequent intervals.

Fig. 2 is an improvement over Fig. 1, and was invented, or at least introduced, by Walton Rutledge, State Inspector of Mines, Alton, Ill. It is in general use in the southern part of Illinois and there is no question but that coal can be caged quickly and cheaply by this method. Its disadvantages lie in the fact that, like the old two-side system, the entries must be driven wide enough for two tracks for a considerable distance,

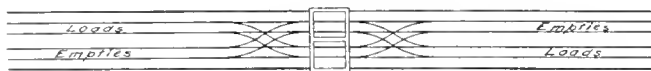

FIG. 1

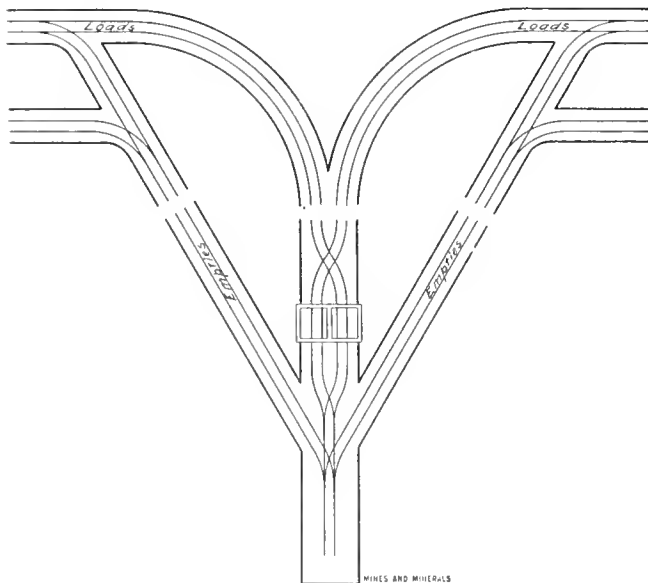

FIG. 2

with the usual accompaniment of expensive timbering and maintenance. Then, too, the exigencies of the case require that passageways must be driven quite a distance without breakthroughs, that the pillars may not be chopped up too much, and this in gaseous mines is a source of no little danger. Last, but not least, in order that the proper gradient may be obtained

* Mine Inspector, Boston, Ill.

in the switchbacks, the bottom must be excavated, which makes a nice lodgement for water, and, if the bottom is hard, is no little job; or the empties must be lifted high enough to obtain the grade by some mechanical means—which will generally be found taking a lay-off just when you are most anxious for it to put in steady time.

Fig. 3 shows a method invented by the writer which is

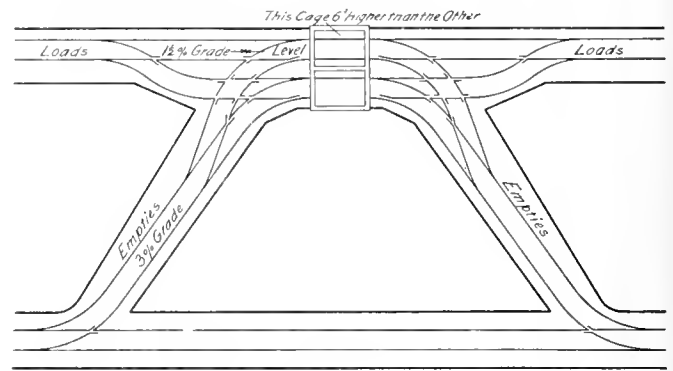

FIG. 3

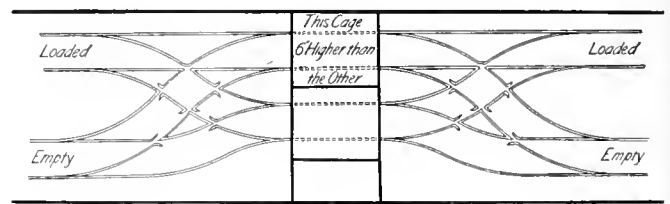

FIG. 4

applicable to all fairly level seams and which contains none of the objectionable features of the other systems.

The main entries can be driven narrow with the exception of about 30 feet on each side of shaft, thus simplifying the timbering proposition where there is tender roof.

Coal can be caged from either or both sides of the shaft, and the empties will take care of themselves without much excavation and with no mechanical handling.

No coal will be hauled a distance of 200 to 400 feet around the shaft as is the case in the one-side bottom shown in Fig. 2.

No mules or motors will come to the shaft bottom but will cut off to get their empty trips at some convenient point up the entry.

All the loads being on single track they can be caged by the minimum number of men—the empties being bumped off the cage from either side of the shaft. All the good features of both methods have been retained, while all the bad ones have been eliminated.

Described in detail the plan is as follows: Sink the shaft so that the main entries will be as nearly as practical on the strike, with the empty tracks to the dip side.

If the seam is level and thick enough, grade can be obtained by filling in at the shaft bottom; or the sump may be sunk deep enough to permit of the bottom being lifted to grade if the seam is thin and it is not desirable to shoot down roof.

The straight track going on to the cage must be as much higher than the other as the per cent. of fall required to gravitate the empties to the empty track—about 6 inches—and the cage dump, or landing, in the tibble should be placed that much higher.

Latches are held by springs, and are always open, thus a load bumping an empty off either cage will always take the empty tracks.

Suitable cut-offs are made at the head of the loaded tracks for mules or motors to drop the loaded trip and pick up empties.

Three or four entries will be required at the beginning according to the method of ventilation adopted, which can be reduced to two or three after the first cross-entries are passed.

If a large amount of coal is to be caged it will be found expedient to cage two cars from one side then two cars from the other, and so on, thus preventing empties from interfering with each other, but this will only be necessary when several cars per minute are being caged. This method will be practical in a majority of cases, and where the roof is bad there is no doubt but that it will be found a decided advantage to be able to keep the main haulage roads narrow.

Fig. 4 is a modification of the system and shows how the tracks can be arranged to operate on the same entry where the roof is good. With this arrangement, empties can be bumped off by the loads and will gravitate to their respective tracks, no matter which cage is down. Nearly all two-side bottoms as now arranged could be easily changed to this plan, and it would be found to greatly facilitate the handling of cars, as both loads and empties have a grade in their favor no matter which cage is down.

The secret of the matter lies in placing the cage and cage landing high on one side of the shaft. We thus secure fall in all directions for the loads and empties, and keep both ropes of equal length.

采 采

Colliery Gas Engine Plants

By Frank C. Perkins

Double-acting gas engines of the four-cycle type now in use for high-power service, have both cylinder ends closed and both sides of the pistons arranged for receiving the power impulse.

For large sizes of 2,400 horsepower capacity, four cylinders are utilized for a single unit, being arranged in twin tandem, as shown in Fig. 2, which is taken from a photograph of the power house at the Bargoed colliery, in England, of the Powell-Duffryn Steam Coal Co., Ltd. For units of moderate size two cylinders are arranged in tandem, as shown in Fig. 1, which is taken from a photograph of the power plant of the Brymbo Steel Co., Ltd., at Brymbo, England. It is held that the tandem arrangement is cheaper in construction than the twin arrangement as the cylinders lie side by side, making two cranks necessary in the latter construction. In Fig. 3 the two twin gas engines of 1,100 brake horsepower capacity shown are at the Societe Anonyme des Arcieres de Micheville, France. In all of these double-acting gas engines of the Nurnberg type,

shown, every stroke has the power impulse like an ordinary single-cylinder steam engine, this being obtained by the introduction of two cylinders, each of which is double acting.

In order that a modern high-power gas engine should be thoroughly reliable and capable of fully competing with large steam engines in every way it is necessary to proportion every part to resist the maximum possible working stresses, and to use only such materials as are suitable for the respective conditions.

It is necessary to allow ample wearing surfaces for the reduction of wear and tear to a minimum; and also necessary to have an effective, well-arranged cooling system; to provide for the best possible methods of lubrication; and it is vitally important that the engine have a reliable ignition system.

The cooling space of the cylinders is large in the engines illustrated and in order to provide effective cooling and to bring the fresh supply of water to the hottest points, special pipes are arranged inside the cooling space which sprinkle the

pockets of the exhaust ports. The piston receives its cooling water through the piston rods, which in their turn receive the water through a link arrangement connected with the middle crosshead.

The cylinder covers are also effectively supplied with cooling water. The return pipes coming from the different parts are all arranged close to each other on one side of the engine, and pour the waste water into a common tank. Each return pipe is fitted with a thermometer and a wheel valve, so that the water temperature of each part to be cooled can be independently regulated to the required degree. The opening of one main stop valve brings the whole cooling arrangement into action, and renders it impossible for the opening of a cooling pipe to be forgotten by the carelessness of the engine driver.

It is stated that the pressure required for the cylinder and exhaust valve cooling water is about 20 pounds per square inch. For the piston cooling, the pressure has to be considerably higher, and about 50 pounds to 60 pounds per square inch should be available. Where water of such a pressure is not available, the engine is supplied with a special water pump, driven by an eccentric and rod direct from the crank-shaft.

The amount of cooling water required for one of these high-power gas engines is about 8 gallons of 60° F. per British horsepower hour, this will be considerably less than the water consumed by a condensing steam engine.

At the Bargoed colliery power house there are in operation three high-power gas engines, having a total capacity of 6,000

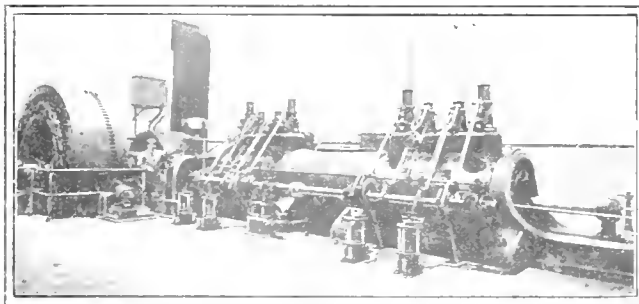

FIG. 1. TANDEM GAS ENGINE AT BRYMBO, ENGLAND

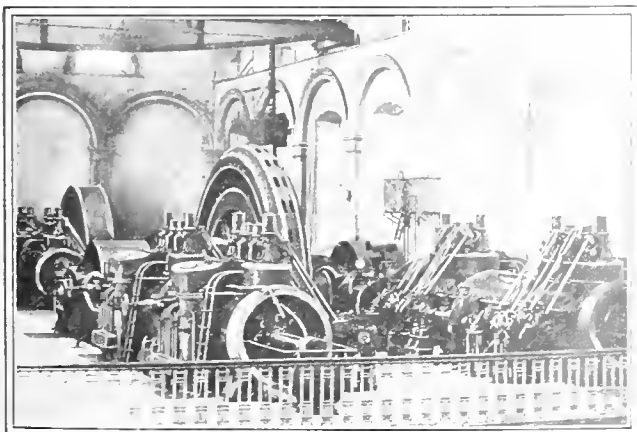

FIG. 2. 2400-HORSEPOWER TWIN TANDEM GAS ENGINES AT BARGOED, ENGLAND

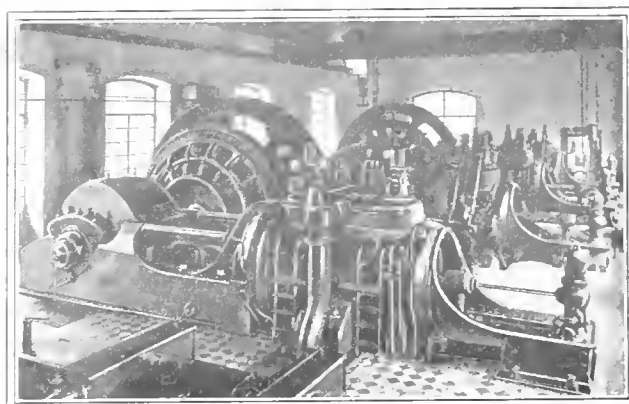

FIG. 3. TWO TWIN TANDEM GAS ENGINES AT MICHEVILLE, FRANCE

horsepower. The first engine installed is direct-connected to a three-phase alternator and develops 1,200 brake horsepower, the remaining two units are of 2,400 horsepower each, one of which is seen in Fig. 2. These engines run in parallel with each other and with a steam engine and exhaust steam turbine some miles away. The Brymbo tandem engine, shown in Fig. 1, develops 900 brake horsepower and is driven by a mixture of coke-oven gas and blast-furnace gas. It operates a three-phase alternator designed and constructed by the Electrical Company, Ltd., of London, while the Nurnberg gas engines were built by Lilleshall Company, Ltd., of Okengates, England.

Trade Notices

Steam, Air, and Gasoline Locomotives.—A circular recently issued by the H. K. Porter Co., of Pittsburg, who have for many years been known as manufacturers of compressed air and light locomotives, states that the company has gone into the manufacture of large and heavy steam locomotives and gasoline locomotives, in addition to the regular line they have been building for the past 45 years. They state that for some time a large portion of their output has been heavy standard-gauge locomotives, extra heavily built along their distinctive lines, in response to customers' increasing requirements. The conditions to be met were steep grades, sharp curves, loads often beyond rated capacity, and long continuous service twenty-four hours daily, which could not be done with any ordinary locomotives. The new specialty, gasoline locomotives, will show the same reliable qualities as the other products of the firm, and within a short time it is intended to keep gasoline locomotives in stock for immediate delivery.

Telephones and Signaling Apparatus.—A catalog recently issued by the Electric Service Supplies Co., of Philadelphia and Chicago, describes telephones and signaling apparatus for mining service, and covers completely the Keystone water-tight mine telephone, underground and office types, pneumatic mine signaling apparatus, and electric block-signal systems, all of which are sold by that company. Several pages of the book are devoted to a discussion of the advantages to be obtained from telephone and signal installations in mines, showing the adaptability of the different devices to the particular conditions for which they were designed. The book should prove of assistance to mining men, and copies may be obtained from either the Philadelphia or Chicago offices.

An Ideal Ore Testing Outfit for Field Use.—A prospector who was a chemist and assayer of wide experience, skilled in metallurgy, and a practical field man as well, while prospecting for tin in the Black Hills of South Dakota, realized from practical experience how helpless the skilled analyst was when away from his laboratory and its appliances. As his blow pipe would not give a satisfactory reduction, and acids failed to put the ore in solution, he set his mind to work on the problem of devising an outfit which could be carried in a coat pocket and be within the reach of the ordinary miner and prospector, and at the same time so simple in operation as to be of value to men of limited education as well as to those who had the benefit of broad technical training. The result was the production of "Way's Pocket Smelter." Over 6,000 of them have been sold in all parts of the world, and the manufacturers, the Way's Pocket Smelter Co., of South Pasadena, Cal., guarantee satisfactory results if the directions are followed. They have published an interesting booklet which describes the outfit in detail, the principles on which it is based and the results of its use, which will be sent free on request.

Engineering Data.—One of the most interesting developments that has come about with our modern systems of great industrial manufacturing combinations and immense and specialized factories has been the production of pamphlets, bulletins, etc., dealing with the technical applications and aspects of the company's products.

It was at first undoubtedly true that these bulletins contained material that was more advertising and laudatory in its nature than replete with concise technical information. It soon became evi-

dent, however, that the engineer desired definite facts concerning the products with which he was dealing. The bulletins accordingly comprised more and more such specialized literature until today they constitute a genuine contribution to the fund of knowledge of the world. The very desire on the part of the manufacturer to be able to place at the call of actual or potential customers all available data caused him to undertake many investigations along lines that might otherwise have been neglected or undeveloped, and these researches have been conducted on a scale impossible for the individual or even the engineering schools.

That the reasons for such endeavor are in the main selfish is undoubtedly true, but there is nevertheless, thereby accumulated a vast amount of information. For some time the Hyatt Roller Bearing Co. has made a practice of issuing bulletins covering in detail the ratings and capacities, indicated uses, and actual application of its flexible roller bearings. Separate issues cover the different types, such as the Long Series for machine tools and similar work; Short Series for automobile service, those employed in standard shafting boxes and those for special work in cars used in the transportation of passengers, freight, and mine products. Forms for the entry of questions or specifications are also provided and with the carefully arranged tables in the bulletins make it easy to procure the proper bearing for the particular instance. These bulletins are at the call of any interested and form a collection of special information worthy of a place in any engineer's office.

Wire Rope.—A new booklet entitled "Wire Rope and the Elements of Its Uses," by Wm. Hewett, M. E., has recently been issued by the Trenton Iron Co. While this is primarily a catalog it also gives valuable information and data in regard to splicing, transmission of power, formulas, etc. It will be sent on request.

Seattle Office.—The Jeffrey Mfg. Co., of Columbus, Ohio, has recently opened a branch office at 1201 American Bank Building, Seattle, Wash., from which the business in the Northwest will be handled. The manager is Percy E. Wright, a sales engineer connected with the home office for the past ten years and thoroughly conversant with the conditions in the northwest territory. The Jeffrey Mfg. Co. now maintains 13 offices in the United States, and nearly 100 agencies in the leading centers all over the world.

The "Wyoming" Steam Trap.—Although a float is employed and is necessary in its action, the Wyoming steam trap does not come under the head known as the float-operated type. The float is only instrumental in releasing the valve weight, which in dropping lifts the discharge valve. No dependence whatever is placed upon the buoyancy or weight of the float to lift the discharge valve from its seat, as is the case with all other float or bucket traps. The valve weight consists of a levered cast-iron ball, the weight of which governs the capacity or size of hole through the discharge valve seat. Therefore by increasing the weight of the valve weight a discharge valve of almost any size can be operated. This is the reason why the capacities of the "Wyoming" trap are from 50 to 200 per cent. larger than other traps, that depend on the float or bucket to lift the valve. In operation the water enters the trap, raising the float to its highest point of travel, when it releases the weight latch and allows the valve weight to fall. In falling, the action of the valve weight in connection with the crank, lifts the discharge valve wide open instantaneously. The discharge valve is then held wide open by means of the rod latch until the water carries the float to its lowest point of travel, which at the same time raises the valve weight. At this point the weight latch again engages and the rod latch disengages, allowing the discharge valve to close instantaneously. The instantaneous valve movement and intermittent discharge is an important consideration, as sudden discharging causes a syphonic action in the pipe line, which draws the water from the pockets along the line. This action is impossible with a continuous-flow trap. To detect the difference between a leak and a discharge of a continuous-flow trap is a difficult matter, as it dribbles continually. With the "Wyoming" trap a waste of steam is detected at once—the valve being entirely open or closed at all times. This trap is made by the W. H. Nicholson Co., of Wilkes-Barre, Pa., who will furnish valuable data to those interested.

Advance in Air Compression

A New Style of Valve Said to Have Advantages Over Those Commonly Used

The fact that compressed air for mining purposes has maintained its ground in competition with other forms of power transmission makes its advantages apparent. During recent years a considerable amount of attention has been paid to the improvement of air compressors, with the result that pneumatic power transmission is as popular as ever it was among mining engineers.

One of the means by which power has been lost has been through the operation of the valves of the compressor. These being usually mechanically operated, the poppet or slide valves required a considerable amount of power to open them on account of the weight, particularly in the larger sizes of compressors. The recent application of the Rogler-Hoerbiger valve has added to the mechanical efficiency of the compressor. This valve consists, as shown in Fig. 3, of a light, flexible, circular steel disk with concentric openings which form ports. This valve works on a cast-iron seating provided with circular rings corresponding to the openings in the valve disk. The valve is ground to a true surface on one side which keeps a perfectly tight joint until it is lifted.

Fig. 3 shows the upper and under side of the valve, in its assembled condition. It will be seen that the lifting portion of the valve is light, and that a small lift will give a large opening for the air to pass, with the expenditure of little power. The valve is provided with light steel springs, two in number on the smaller sizes and four on the larger, which close the valve smartly when the pressure on the end surface is removed; that is to say, when the piston reaches the end of its stroke. The advantage of this is that owing to the absence of back flow of air the volumetric efficiency is very largely increased. Since the valve has no sliding parts lubrication can be done away with without increasing in any way the wear and tear of the valves. Yet another advantage will be apparent to any one who has seen these compressors in action; even at the highest speeds the reliable action and silent working of the valves is noticeable.

The ordinary form of compressor made with these valves for use on work of an intermittent nature, when only small

quantities of air, say 75 pounds pressure to the square inch, or large volumes of air, with low pressure are required, is the horizontal, single-stage, double-acting type with water-jacketed cylinders, and air valves either in the cylinder barrel or in the end of the covers of the cylinder. In this type the leading points are compactness, accessibility, and simplicity. As the parts subjected to wear are few, the attendance and cost of upkeep is minimized. In some cases the compressor is fitted with an automatic pressure regulator, which allows the compressor to run idle as soon as the pressure in the air receiver exceeds a predetermined limit, and which brings the compressor into action should the pressure fall below this limit. In the case of belt drive, the compressor is sometimes fitted with an automatic belt-shifting device which, when the pressure rises, pushes the belt on to the loose pulley and when the pressure falls, pulls the belt back to the fixed pulley, thus making the plant entirely self-contained. If electric current is available it is found advisable to effect the driving of the smaller compressors with electric motors by means of belt, electric driving being smoother and considerably prolonging the life of the compressors, as compared with steam drive, which is often a source of trouble for small plants.

A very interesting development from the above type is a horizontal, single-cylinder, two-stage air compressor which has been designed in order to take advantage of two-stage compression even for units of small and medium capacity without incurring the expense of two cylinders. This type of plant is found to be most useful where only a small amount of floor space is available, inasmuch as the compressor is very compact, particularly substantial, rigid, and suitable for heavy and continuous work. A plant of this description is shown in Fig. 1. The two-stage compression is effected by the use of a differential piston, the first stage of the compression being effected in the

space between the rear side of the piston and the back cover of the cylinder. The second stage takes place in an annular space between the trunk end of the piston and the cylinder wall. The cylinder is water-jacketed and the air on its way from the low- to the high-pressure side of the cylinder passes through an intercooler of ample capacity, attached to the top of the cylinder, and provided with brass tubes through which water circulates. It will thus be seen that, as the temperature of the air is greatly reduced before entering into the high-pressure side of the cylinder, the volumetric efficiency of the compressor is considerably

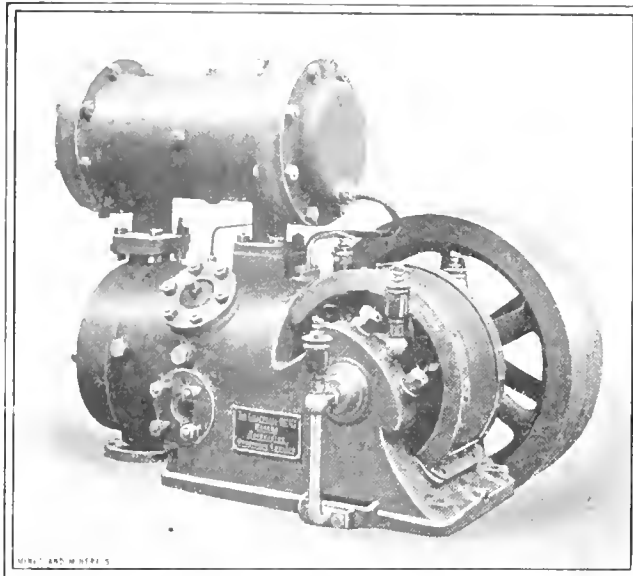

FIG. 1. SINGLE CYLINDER TWO-STAGE AIR COMPRESSOR

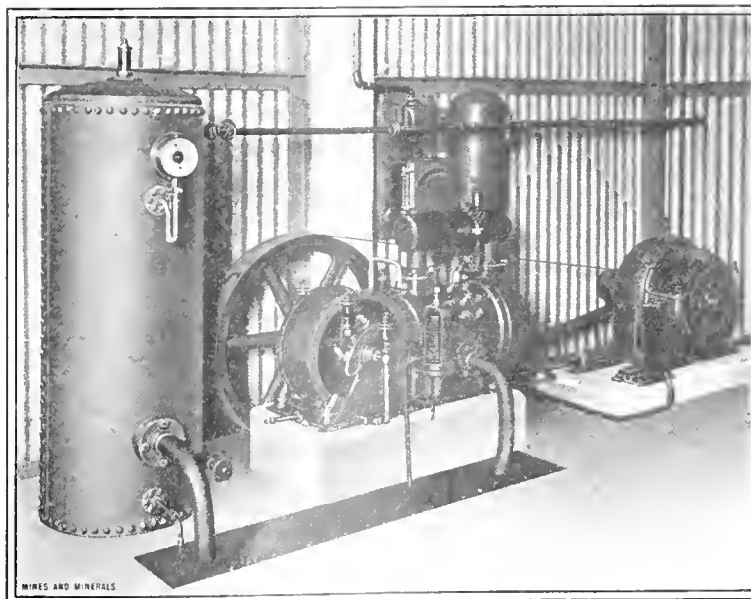

FIG. 2. ELECTRIC DRIVEN COMPRESSOR

increased. In Fig. 2 will be seen a typical installation employing one of these compressors driven by means of electric motor.

The type of Kogler-Hoerbiger valves is not, however, limited to compressors of the smaller sizes, as horizontal, two-stage, belt-driven air compressors that deal with large quantities of air at high pressure are constructed. One of these is a horizontal gas compressor at the United Alkali Co., Widnes, Lancashire, which is driven by a double-acting four-cylinder gas engine, of the Nurnberg type of 600 horsepower running on producer gas. This machine compresses 1,820 cubic feet of lime-kiln gas or carbon dioxide per minute to 40-pounds pressure

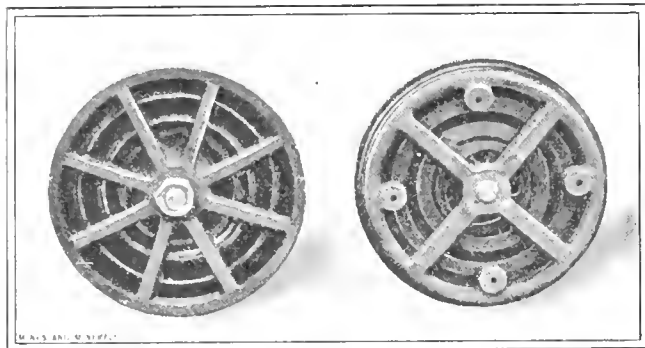

FIG. 3. UPPER AND UNDER SIDE OF VALVE

per square inch, and delivers it to a chemical works for certain chemical operations. The diameter of the gas-engine cylinder is $25\frac{1}{2}$ inches, while the diameter of the compressor cylinder is $31\frac{1}{2}$ inches. The stroke, which is common to both cylinders, is $29\frac{1}{2}$ inches, and the engine runs at 80 revolutions per minute. This plant is of special interest, as it is the first of its kind to be arranged in this manner; that is to say, driven direct by the gas engine and having the compressor fitted with the valves described above.

采 采

The Carbondale Mine Fire

By F. Webster Brady, M. E.

At the regular monthly meeting of the Engineer's Society of Northeastern Pennsylvania, held in Scranton, Pa., October 19, an informal discussion was had on the Carbondale, Pa., mine fire.

The property on fire is about 200 feet above the Lackawanna River, and in the suburbs of Carbondale. It comprises about 50 acres, and is underlaid with six seams of coal. The top seam is about 5 feet thick and has very little rock cover. This seam is estimated to contain about 5,000 tons of pillar coal. The second seam, which is about 6 feet thick and lies about 8 or 10 feet below the first seam, covers about 35 acres. It has been mined and the pillars partly robbed. The area extending beyond the outcrop of the first seam was stripped by steam shovel. It was during the stripping operation that hot coals from the shovel boiler furnace set fire to the refuse in the bank, and finally to the pillars in the seam.

The third seam covers an area of about 46 acres. It was nearly mined out and most of the pillars robbed about the year 1890. When the mine was abandoned, it was estimated that there were about 100,000 tons of coal in seams two and three, and it is this coal that is feeding the fire today.

There have been some mining operations in the fourth seam, but these have been limited owing to the thinness of the seam. The fire has now gotten into the workings of the fourth seam. The fifth seam has been mined extensively. The sixth seam is 70 feet below the fifth and has not been worked.

The first report on the area of the fire was made in 1906 by Frank G. Wolfe, E. M., of Scranton, for the Finn Coal Co. that was operating at this time. The fire was mostly in seam number two and covered probably less than 5 acres. The Finn

company attempted to cut off the fire but it got down into seam number three, and today the fire area is about 36 acres. The spread is estimated to be over 5 acres per year, and the rate westward toward the city of Carbondale at about 10 feet per month. The outcrop which will limit the westward burning is about 600 feet in advance of the present fire line which is now under the reservoir. This western section is more thickly populated than any other as it lies in the city proper. The prospective damage in this section to both private and city property will be quite large as there are 32 private properties on the surface affected by the present fire area. On the south the fire can extend beyond the Canaan road and will eventually destroy all the residences along this road. On the north, the seam crops and the damage from the spread of the fire in this direction will be comparatively slight. To the east the fire will spread into the abandoned workings of the No. 3 seam of the Black Diamond Co., where it could continue burning for many years.

The present conditions over and about the fire area are bad. The surface is honeycombed and there are burning craters. At night and on muggy days the air in the locality is heavily laden with sulphur fumes that make habitation almost unbearable. Gaseous explosions occur occasionally, tearing the surface open and increasing the danger to those who live near. Any one traversing that vicinity might fall through and be smothered.

The State Legislature during its last session appointed a commission to investigate the conditions of the Carbondale fire and report a remedy to the Legislature. The commission recommended that steps be taken at once to prevent the fire spreading, and that the "ditch method" be used. This method consists of opening a trench around the greater portion of the fire area, the estimated length of trench being 6,100 feet. The trench would have to sink through the third seam, which would require an average depth of from 40 to 50 feet, with a width of 20 feet at the bottom, and 60 feet at the top. The cost was estimated at about \$200,000. The Senate took favorable action, but the House turned it down when some complications came up over the contractors that might perform the work.

The trench method was pretty generally discussed by the members of the Club. The consensus of opinion was that this was the only one that would limit the spread of the fire. There were quite a number of suggestions regarding the dimensions of the trench, as to how it should be made, and the nature of the materials for filling it. It was agreed that the trench should be of considerable width, 12 feet or over, in order to prevent the heat of the burning outcrop from igniting the coal just across it. For filling material, sand was considered best. Clay, ashes, and silt flushed in with water were good, but clay would contract when heated and thus open up fissures that might let the fire across. Where the trenching was in rock and the walls would stand, the trench could be more narrow than in looser ground. Also, where good filling material was not available, a 4-foot concrete fire-wall, or ribbon, resting 5 feet below the bottom slate and 5 feet above the top slate could be constructed. The concrete-wall scheme has been used successfully in other cases to stop the spread of mine fires. At some locations where ditching might be difficult it was thought feasible to put down 12-inch bore holes and flush sand and clay into the workings so as to form dams. Some concrete work could also be done in making these dams.

It was not considered feasible to put out the fire in the area which it now covers. The fire must burn out and the time might range anywhere from 10 to 20 years. Two or three plans were proposed to fight the fire and lessen the injury to the residents from a fouled atmosphere. One was to lay 4 miles of 8-inch wood pipe to a location in the Lackawanna River where the head would deliver water to several of the mine openings. Heavy flooding would then be resorted to. The cost of this method for a period of 5 years was estimated at \$75,000. It was practically conceded that the flooding system could not put

out the fire. This decision was based on the known condition of the mine workings. The seams are close together, and the ground badly broken between them. Only about one-third of the property could be watered. The ground is open like a sponge and the water could not be controlled. Flooding has been effective for drowning out fires in some mines, but in these cases there was considerable dip to the seams, and the water supply could be properly located and controlled. To be successful with the flooding in the fire areas requires solid ground and places where dams can be used to hold the water.

Instead of ditching the property, it was suggested that the coal be mined around the fire area, thus forming the safety ditch naturally. But the idea was not considered with favor because it was too hot for mining work. This scheme had been tried in one case and had to be abandoned for the regular open-ditch method.

Covering the fire area with several feet of clay or with concrete, and erecting a stack at the highest point to carry off the gases was mentioned as a method used with success abroad. But the area at Carbondale is so large and the ground so broken and filled with craters, that the covering scheme does not seem practical. The fire is fed by gases coming from below and the smothering method would result in explosions which would shatter and open the surface.

The Carbondale fire has been burning for 7 or 8 years, and the reason that nothing has been done to stop it is because the fire was started by parties other than the owners. The property is a poor mining proposition, and the present owner of the coal seams, Mrs. Watt, could not possibly do anything to protect it.

采 采

Testing Gasoline Mine Locomotives

In this country no standard width of gauge or weight of rail has been adopted for industrial-haulage systems. As a result, locomotives for mining and industrial purposes must invariably be built to suit the existing conditions in the matter of gauge and length of wheel base. Thus, in the design of a testing device, the problem is to provide a simple, ready method of adjusting the device to various gauges and wheel bases and to provide also a track on which the locomotive can travel to its proper position over the testing pit.

The testing-pit device shown in Fig. 1 was gotten up by the Milwaukee Locomotive Mfg. Co., and is interesting to users of mine locomotives as showing the length to which reputable manu-

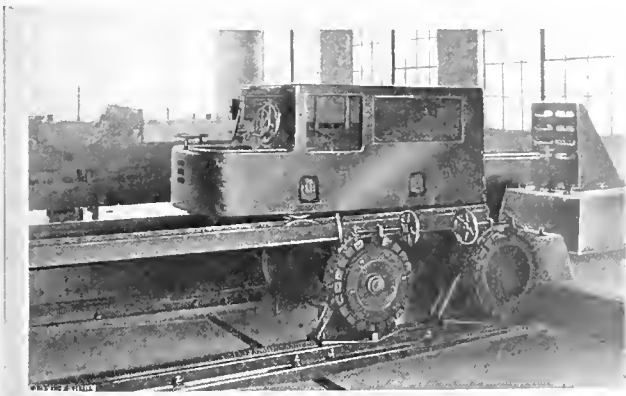

FIG. 1. LOCOMOTIVE TEST PIT

facturers of mining machinery go in order to be able to make their statements and guarantees good. This concern recently completed a 60' x 120' testing house, half of which is devoted to testing locomotives, while the other half, shown in Fig. 2, is arranged for testing gas engines.

The heavy cast-iron frames of the testing device are imbedded in the concrete bottom of the pit, to form a support for the pedestal bearings of the roller shafts. The pedestals are adjusted by rack and pinion in the longitudinal direction of the frames, to secure the desired length of the wheel base. The cross-shafts of the pedestal bearings are fitted with drums on which the rollers slide sideways. T-head bolts in the long hubs of the rollers engage in longitudinal slots of the drums, locking the former in the required position and thus making it possible to adjust the width of gauge as desired.

The top of the testing pit is spanned lengthways by track rails on which the locomotive travels to its position over the rollers.

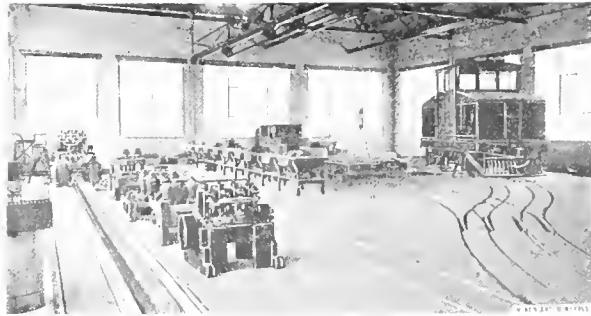

FIG. 2. GASOLINE ENGINE AND LOCOMOTIVE TEST HOUSE

Each of these rails is made of two heavy angle irons placed parallel and so spaced as to permit the rollers to project upward between them. The flanges of the angle turn outward to form a broad base for the rail which rests at the ends on flat plates built into the concrete end walls of the pit. The rails are easily shifted sideways with the rollers without being lifted. Removable sections of cast iron rest on the upturned edges of the angle irons, forming the track rail for locomotive wheels having either inside or outside flanges as the case may be.

When a locomotive has been assembled in the erecting shop, it is lifted on to a special steel transfer truck by means of overhead cranes. The floor of this truck is provided with rails spaced for various gauges and of suitable level for running the locomotive on to the testing table. The transfer truck is hauled to the testing house over a system of standard shop tracks, the motive power being furnished by a gas-driven locomotive of the company's manufacture.

When placed on the testing table the wheels of the locomotive rest on the rollers, each pair of which is rigidly fastened on a shaft, on whose outer end is a friction drum and band brake to provide the necessary resistance to rotation. By means of a dynamometer attached to the drawbar, continuous drawbar pull and speed in miles per hour is automatically registered on a sheet of paper which serves as a permanent filing record. This method of testing also permits the action of all moving parts to be closely observed, conditions that cannot be satisfactorily noted when running tests are made on ordinary outdoor tracks.

Before it is permanently installed in the locomotive, the gas engine is given a thorough test. It is placed on movable supports, over a concrete trench containing water and exhaust piping, the oil and gasoline supplies being drawn from conveniently located points in the piping system, as shown in the illustration, Fig. 2. Parallel with the test rack is a track over which a dynamometer truck can be quickly moved and coupled to the gas engine that it is desired to test. Power and endurance tests are then made and recorded.

A further labor-saving device is a cranking motor which consists of an electric motor mounted on a light hand truck. This truck can be moved up and coupled to the gas engine, which is then started by the cranking motor, the motor automatically disengaging itself when its function is performed.

Extinguishing the Majestic Mine Fire

Investigation by Men Wearing Oxygen Helmets Rendered It Possible to Take Effective Action

By R. Y. Williams, A. B., E. M.*

Conditions of Franklin County, Ill., that make coal mining dangerous offered an opportunity for R. Y. Williams and J. M. Webb, of the United States Geological Survey Rescue Station at Urbana, Ill., to lend assistance with rescue apparatus at the mine of the Majestic Coal and Coke Co. Mr. Williams' account of this fire extinguishing work is one of the best on record, and should be carefully read by all coal-mining men.—EDITOR.

Franklin County coal is mined in the central part of the southern coal field of Illinois, and is considered among the best in the state. The seam worked in this field is the No. 6 or "Blue Band" seam of the Illinois series, also formerly known as the No. 7 seam because of its superiority over the No. 6 seam to the northwest. The seam lies practically level, has a thickness of 9 to 14 feet, and is generally very clean except for occasional sulphur balls and the persistent "Blue Band" slate which runs 1 to 4 inches thick 18 to 20 inches above the floor. It is customary to leave top coal for roof because of the treacherous character of the black slate above: the floor is a medium hard clay. Six samples of this coal, taken from different mines in Franklin County, analyzed by one of the chemists of the United States Geological Survey, Pittsburg, Pa., yielded the following results:

Air Drying Loss	Analysis of Air-Dried Sample				B. T. U. Computed to Ash and Moisture Free
	Moisture	Ash	Sulphur	B. T. U.	
7.8	2.42	6.62	1.01	13,145	14,450
7.6	2.27	7.15	1.04	13,090	14,450
6.8	2.19	8.19	.99	12,955	14,454
3.7	5.89	8.66	1.06	12,395	14,504
4.8	5.87	6.66	1.00	12,711	14,528
3.5	5.16	8.14	1.56	12,551	14,476

The mining of Franklin County coal is generally admitted to present great dangers from explosions and fires. Franklin County, with its nearby southern counties, contains practically all the gaseous mines of Illinois. The series of disastrous explosions at Ziegler, Rend City, and West Frankfort is familiar to every mining man in the state. The danger from fire is so great that many operators when black powder was used employed "fire hunters," who followed the shot firers and inspected as quickly as possible each face after the shooting. The superintendent of a mine that produced 2,500 tons a day stated that on the average the "fire hunters" in his mine discovered and put out 20 fires each shift.

When a fire originates in a Franklin County mine, if it is allowed to gain any headway, it is sure to make a dangerous situation. There are entire mines, as well as certain areas in other mines, that are at present sealed up because fires resisted the efforts of the miners to subdue them with water or chemicals. Until recently, most mining men considered that 30 to 60 days would be a period sufficient to smother any fire within a carefully sealed area; this opinion was based on the thought that large quantities of blackdamp, formed by the combustion, would kill any fire present. While the fire-smothering action of blackdamp must be admitted, several instances of the continuance of fires during long periods, and within closely sealed areas, have recently been observed. For example, in February, 1909, there was an explosion in the West Frankfort mine, known as Dering No. 18, and because the explosion set fire to the mine both shafts were immediately sealed with reinforced concrete. When the shafts were unsealed in June, 112 days later, black smoke was observed issuing from the upcast

shaft as soon as ventilation was established, and a slight explosion or "puff" indicated the continued presence of the fire.

Furthermore, in the Franklin County field, fire-sealed areas rapidly fill with methane, which readily yields an explosive mixture of gas as soon as ventilation shall have furnished sufficient oxygen. In the West Frankford mine mentioned above, after the fire was found to be still burning, it was decided to flood the mine. Several weeks later, during a severe rain storm, large quantities of water were run into the mine by means of surface ditches. During this work, sufficient air was carried down the air-shaft by the falling water to supply the oxygen necessary to unite with the gas present to form an explosive mixture. When this body of gas passed over the flame of the fire, an explosion occurred that tore the concrete off the hoisting shaft and drove a mine rail (which had been used as a reinforcement to the cement) 30 feet into the superstructure of the tippie.

Because of these dangers great care is exercised in Franklin County by both operators and miners to safeguard life and property. There seems to be a general tendency to get away as much as possible from "shooting off the solid," especially in narrow work, and to introduce mining machinery for cutting the coal, in spite of the low differential in favor of the machine-cut coal. Successful efforts have been made in introducing "permissible explosives," and the results are proving satisfactory. At one mine, where all the coal is cut by machinery, 75 per cent. of the coal is shot with a permissible explosive, and as a result, for several months there have been no windy shots and no fires, and the roof has not been bruised, as had frequently happened with the use of black powder.

These facts serve to make the more interesting the successful recovery of a large fire-sealed area in the Majestic mine, Perry County, Ill.

The Majestic mine, operated by the Majestic Coal and Coke Co., is located 5 miles east of DuQuoin, near the western boundary of Franklin County. This mine has a capacity of 2,000 tons per day of 8 hours, and is developed in the No. 6 or "Blue Band" seam, which at this location is about 9 feet in thickness and lies under a cover of 400 feet. The mine is worked on the room-and-pillar system, the main entries running east and west and the cross-entries north and south. Rooms on 50-foot centers are driven east and west off each pair of cross-entries, and are allowed to hole through into the rooms of the adjacent entries. This practice works a serious hindrance when it becomes necessary to seal off a mine fire.

It is customary at this mine in the advancing workings to leave up 2½ feet of top coal as roof, to rob the room pillars as soon as the rooms are completed, and to take the top coal in the retreat.

This is not considered an especially gaseous mine, but the methane factor has to be carefully watched. The coal is rich in volatile matter and is highly inflammable. Ventilation is maintained by a reversible fan which ordinarily runs as a blower, forcing the air through the mine as shown by arrows on the map, Fig. 1.

At 9 o'clock in the evening of September 20, 1909, a charge of black powder was fired in the top coal of room No. 27 on the second south off the main east entry at the point on the mine map marked with a cross. In an unknown manner, the blast set fire to the coal and started what proved to be a serious fire, that was not discovered until 2 o'clock on the morning of September 21, 5 hours after the shot had been fired. During the balance of the night, continued effort was made to fight the fire with water, but as the attempt to control it was unsuccessful, it was decided at 8 o'clock in the morning to seal it off. To accomplish this, stoppings were quickly built of two thicknesses of 1"×12" shiplap boards, made tight with gypsum products and wood-fiber plaster. The stoppings were located at points where the heavy line enclosing the fire area on the map crosses entries and cross-cuts.

At 4 o'clock that afternoon the building of the stoppings had advanced until it was considered that the fire was under control, but it was 4 o'clock on the morning of the 22d before the sealing was completed. Then the room necks on the first south off the main east were bratticed in order to force air along the line of fire-

* Mining Engineer, U. S. B. of M., Urbana, Ill.

stoppings in the cross-cuts between the first and second south entries and thus to prevent the accumulation of bodies of marsh gas. This enclosed the four south entries off the main east, and also the rooms thereon—an area approximating 40 acres and one that required the building of 29 fire stoppings. The following day mining operations were resumed in the balance of the mine.

Naturally, the sealing off of this large territory containing about 60 working places, occasioned a serious curtailment in the production of the mine, and the filling of the enclosed area with methane (CH_4) presented a constant danger to the miners. Accordingly, on the 4th of December, 74 days after the origin of the fire, James M. Webb and the writer, acting on the invitation of the Majestic Coal and Coke Co., arrived at the mine with the rescue apparatus from the Urbana Mine Rescue Station.

After the apparatus had been unpacked and charged, a number of mine bosses and company men were trained on the surface in the use of the oxygen helmets, and then an inspection was made of the stoppings surrounding the fire region in the mine. These stoppings were found to have been carefully built and well plastered; but in a number of instances the plaster had dried and cracked, permitting leakage.

A bottle sample of the air in the fire-sealed area, taken from one of the stoppings through an iron pipe, showed the following: Carbon dioxide, 3.6 per cent.; oxygen, 5.6 per cent.; carbon monoxide, .1 per cent. Careful tests with a safety lamp indicated that the mixture was explosive when mixed with air—a fact further suggested by the above analysis, which leaves 11 per cent. of oxygen unaccounted for.

At this point the plan of campaign adopted included the reversal of the fan, in order that the gas when moved should be exhausted out the air shaft leaving the hoisting shaft pump room, stables, and main entries on the intake of the air, and the building of an air lock in an entry cross-cut as near the point of origin of the fire as possible, in order that an inspection of this important place could be made as easily as possible with the aid of the helmets and with the admission of the least possible amount of fresh air. The location of the air lock is indicated with a circle in Fig. 1, and consisted of two board stoppings 8 feet apart with a door built in the outside stopping. Building of the air lock occupied the remainder of the afternoon.

The next morning a sudden drop in the barometer made it advisable to postpone the work until afternoon, when two men wearing helmets and carrying electric safety lamps entered the air lock and made a door in the inside stopping. After this was completed, helmet men made thorough inspections of rooms 27, 28, and 29. The report of all these examinations showed no fire, no smoke, and no heat; but indicated a very heavy fall of roof in room 28. The course of the ventilation at the time of the fire had carried the heat and flame from room 27, through the last cross-cut between rooms 27 and 28, into room 28, occasioning the heavy fall mentioned above.

In spite of the reported absence of heat, the heavy fall in room 28 indicated a point of danger from a buried fire, considering the known manner in which fires had continued for long periods in sealed areas. It was therefore deemed unsafe to open the fire-sealed area in such a manner as to restore ventilation to its usual

course, because of the following dangers: (a) Hundreds of thousands of cubic feet of explosive gas would be passed over the fall in room 28; (b) the ventilation would fan a smoldering fire into a blaze; (c) an explosion would take place if the explosive gas came in contact with the flame; (d) it would be a long time before this body of gas could be removed, and in case the fire was revived, it would be a long time before men could safely enter and begin the work of cleaning up the fall and fighting the fire.

In order to exhaust this body of gas from the fire region without passing but little gas over the heavy fall in room 28, the following steps were taken in order of their enumeration:

1. The room-neck brattices along the first south entry were made tight enough to pass all the air needed along that entry.
2. The stopping at the extreme south end of the fire-sealed area at the point marked A on the mine map was removed.
3. A canvas curtain was hung across the first south entry immediately south of the cross-cut containing the air lock, as shown at E on the accompanying map.
4. The stopping at the extreme north end of the fire-sealed area at point marked B on the map was removed.

5. The doors of the air lock were opened, allowing ventilation to enter, to split as soon as it had entered the fire region, and to travel, part going north and part going south, as shown by the dotted arrows on the map

This was begun at 9 o'clock in the evening of December 5.

December 6 the room was inspected (this time without helmets) beginning at 5 o'clock in the morning. The indications were that there was a certain amount of heat making over the heavy fall in room 28. The top coal, which had fallen 150 feet back from the slate fall, was thrown off the track and work was started loading out the

slate, which amounted to a matter of some 500 tons.

Shortly after this work was well under way, smoke was seen coming from the heavy fall. At 2 o'clock on the morning of the 7th, a certain glowing of the coal was found, and from that time on until about midnight, when the fall was completely removed, chemicals were used in order to control the fire. For this purpose the coal company had on hand five 8-gallon and three 5-gallon fire extinguishers.

Whenever the contents were exhausted the extinguishers were refilled at the mine with soda carbonate water, and a supply of sulphuric acid in a glass container. These recharged extinguishers were taken in to the fire, and when needed the iron rod of the extinguisher was rammed down breaking the glass container, which allowed the sulphuric acid to act on the carbonate to form carbon dioxide. The force thus generated threw the carbon dioxide and water on the fire through the 3 feet of hose and nozzle attachment to the extinguisher. About 100 gallons of this chemical mixture were used in this work

The above description of the recovery of the fire-sealed area in the Majestic mine shows how modern mine-rescue tactics tend to eliminate the uncertainties connected with mine recovery by substituting definite information gained from a careful reconnaissance by helmet men, for without the actual knowledge of the conditions existing it would have been exceedingly difficult and perhaps impossible to have dealt with it successfully.

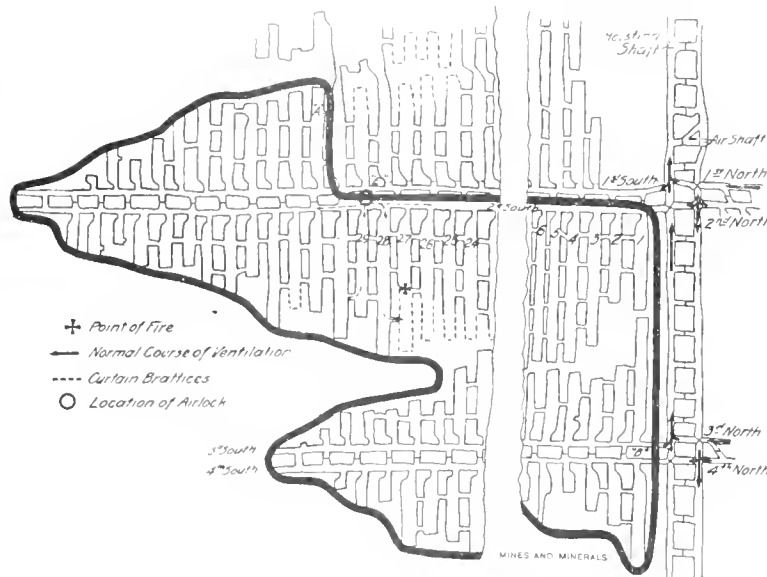

FIG. 1. MAP OF PART OF MAJESTIC MINE

Shafts for American Coal Mines

Methods Employed in Sinking—Dimensions, Timbering, Lining with Concrete, Etc.

By R. G. Johnson*

The following paper was read before the West Virginia Mining Institute under the heading "Shafts and Shaft Sinking for American Coal Mines."

It is the purpose of the writer in discussing the general subject of shaft sinking to describe the design and construction of modern coal-mine shafts in this country. To sink through 170 feet of running sand requires methods which are distinctly products of later-day engineering. In the newer developments and through the thicker overburden, concrete drop-shafts are now sunk. These are concrete shells, usually cylindrical in shape, with a steel cutting edge, a general design of which is shown in Fig. 1. The excavation is done with orange-peel buckets, and as the caisson sinks the concrete is added at the top. The thickness of the shell is designed for weight to aid its dropping as well as for hydrostatic pressure. Boulders, hardpan, etc., require blasting under water. The difficulties are readily imagined when it is remembered that soft-ground shafts are sunk many feet under water at depths too great for pneumatic caisson work. A number of shafts have been sunk under air pressure, and where the head of water is not too great this is the ideal way. When the cutting edge of the caisson has reached the solid rock it is sealed. As shown in Fig. 2, a decking, usually of timber, is placed in the shaft 8 feet or so above the cutting edge of the concrete caisson. In this deck are openings, usually two in number, in which are placed flanged steel cylinders about 3 feet in diameter. To these cylinders are attached air locks, one arranged for hoisting and one for the passage of men. The compressed air is admitted

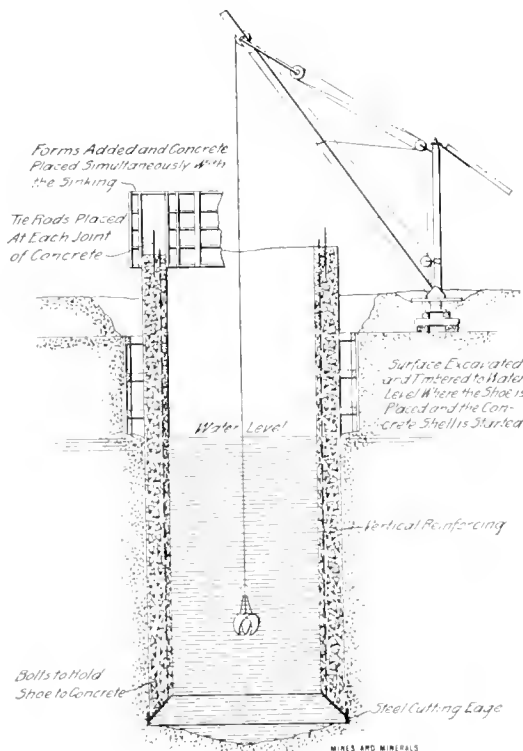

FIG. 1

to the working chamber by pipes through the air deck. When the air is turned on, an extra quantity is needed to force the water out of the working chamber. The men are then put through the lock to work. High air pressures are exceedingly dangerous, and as depth increases the wage per shift increases and the length of shift

* Engineer with Dravo Contracting Co.

decreases. The depth for pneumatic sinking is about 100 feet below water level, for few men can stand the air pressure necessary to overcome the head of water at this depth.

The deep European shafts are circular or elliptical in shape and lined with brick, concrete, or iron tubing. In going through wet strata a process of forcing down a steel cylinder with hydraulic

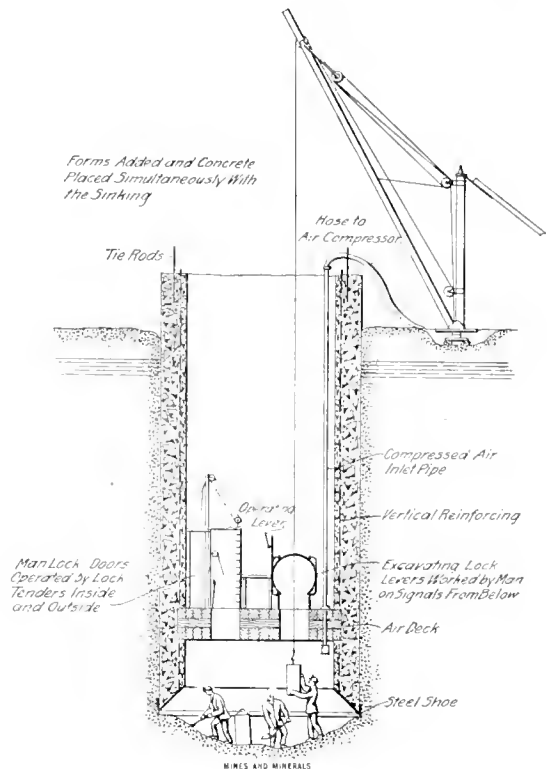

FIG. 2

jacks, sections being added at the top as the cylinder is worked down, has been used very successfully, and engineers are talking of its use in sinking some of the shafts for the Brooklyn end of the new Catskill Aqueduct for New York City. The wet sand which overlies the rock in the lower section of Brooklyn is about 150 feet thick with the water level about 45 feet from the surface. The lining of the European shafts, however, is different from our practice. When the shaft is to be lined with brick the method is to lay on a hanging scaffold, so constructed with a hole in the center that the hoisting bucket can pass through and the sinking operation be carried on beneath simultaneously with the lining process. A cast-iron ring in sections bolted together is placed on a circular hitch in the rock as a foundation for the brickwork. Cast-iron tubing is placed in substantially the same manner, the tubing being in segments, machined and bolted together in the German shafts, but placed with rough leaded joints in most of the English types. In wet strata, cement grout is forced in behind the tubing.

It is seldom that shafts are lined with the timber placed "skin to skin," that is rings of timber placed directly on top of each other without any intermediate posts and without lagging. Timber is too expensive to permit of such extravagant usage.

The two types of shafts which will be considered in new plants are the timber-lined and concrete-lined forms. A brief discussion of the general features of the former is given in order to contrast the improvements that are being made in the concrete-lined type. Timber shafts are usually rectangular, and in the mining of coal a shaft mine must have at least two passageways to the surface. Aside from the fact that most state laws specify that there shall be two distinct openings to the surface available for every mine, the shaft bottom layouts and the plan of air-courses practically dictate that the escapeway and one airway shall be in one shaft and the hoist compartments and the other airway in another shaft with

the pipeway placed in either opening according to the mining engineers pump-room layout, but usually in the hoisting shaft next to one cageway. In designing the shafts, the operator decides on a certain output per day to which his mine will ultimately develop. On his coal acreage will largely depend the kind of plant which he can afford to install. His daily output will determine the size,

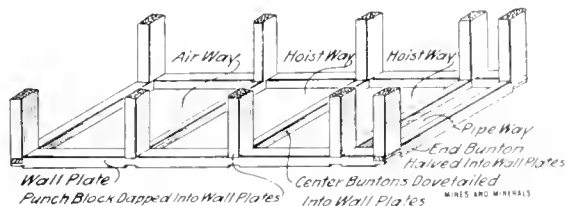

FIG. 3

and the estimated life of the mine will determine the kind, of equipment. When his output is determined, that is, the number of cars per day to be hoisted, the size of the car is determined. The thickness of the coal to be mined, and the grades, etc., determine within certain economical shoveling limits the height of the mine car, and the area of the car is readily figured when its cubical contents are specified. With the adoption of a standard car, the cage dimensions are fixed and the size of the hoisting compartments as well. With the width of the shaft determined by the cageway, the hoisting shaft airway is to be dimensioned. If the fan is to be placed at this shaft, the air compartment is partitioned from the cageways. The size of the fan airway depends upon the number of men to be worked in the mine and whether animals are to be used for haulage.

For every 1,000 cubic feet of air required in the mine there should be 1 square foot of air compartment. If a blower fan is placed at the escapement shaft, usually called the air-shaft, the return airway is placed in the hoisting shaft. It is not necessary to partition this from the cage compartments as is often done. Many believe that by leaving off this partition the cageways can take a portion of the air and hence the return airways can be made much smaller. The mining laws of most of the states dictate that the escapeway shall be provided either with a stairway or a hoisting cage. Tennessee and Illinois specify a stairway, and the former even specifies the minimum dimensions, an exceptionally good thing. In West Virginia the law specifies that either a hoisting way or a stairway for men shall be provided, but does not specify minimum dimensions. If a cageway is used it should be of ample size to carry the standard mine car so that it can be used as a supply and repair shaft. Stairway compartments are usually about 6 feet wide and the flights are placed at about a 45-degree angle. The last of the essential compartments, the pipeway, is determined by water conditions in surrounding mines. If shafts are to be sunk in a new territory a pipeway should undoubtedly be placed as the shaft is sunk.

With the determination of the size of the compartments the dimensions of the timbers are decided. Rock pressures are practically indeterminate. Sandstone actually requires no timbering if the rib is properly scaled down, that is, trimmed of loose or shattered pieces. Only enough timber to support guides, air partition, stairs, and pipe clamps is necessary in sandstone. In good limestone the same is true, but lime shatters more than sandstone and the scaling is too often not thorough. Bastard lime, that is lime with fireclay or slate or sandstone, is very treacherous; and pure fireclay likewise requires heavy timbering, for with the action of air and water it rapidly disintegrates and swells. Notwithstanding oft heard assertions of the squeezing of fireclay beds, the writer has never seen timbers bent from the pressure of a squeeze. He has seen timbers bowed at soft strata but repairs always disclosed a cave-in or slip,

due probably to the shattering and disintegration in the cracks. It therefore behooves the designing engineer to figure strongly in fire-clay country; 8"×10" or 10"×10" white oak or long leaf yellow pine are the usual requirements. These are framed in sets spaced 5 feet center to center. Some engineers will space the timber sets on 2½ feet centers in soft strata and it is a wise plan. Generally with 8"×10" timbers on 5-foot centers no span longer than 12 feet should be used. If conditions require longer spans the timber should be heavier and the center to center spacing shorter. The long side timbers of a set are called the wall plates, the end timbers are called end plates or end buntons. The timber braces divided into compartments are called center buntons or dividers, and the vertical posts which separate the sets are called punch blocks. Behind the sets is placed lagging, usually 2-inch plank. See Fig. 3.

Set accurately to plumb line and gauge, the guides for the cages in the hoist compartments are lapped over the buntons and bolted to them usually with lag screws. The guides should be the best long leaf yellow pine and framed with exceptional care. There are several schemes of splicing the guides; the simplest, which is the half-together joint, is probably the best. There are also many schemes for attaching the guides to the buntons other than direct bolting, as shown in Fig. 4, one using angles screwed to the buntons and bolting the guides to the angles, but here again the simplest form is the best.

The partitions in the shaft are of yellow pine tongued-and-grooved sheathing, usually two layers of 1-inch material spiked with loose joints to the buntons. Stairways are usually built of the same material as the shaft timber as recent tests have shown less rot from oak on oak or from pine on pine than from oak with pine.

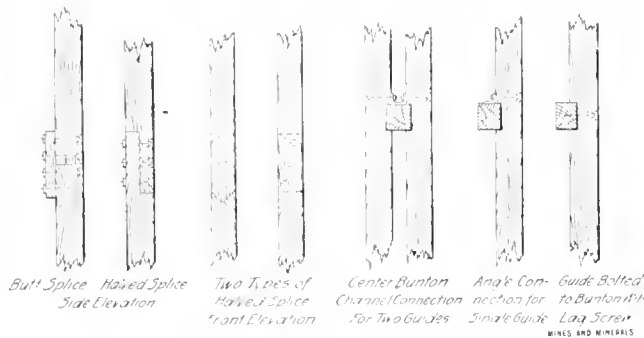

FIG. 4

When water is encountered in the sinking in quantities which it will be objectionable to let fall in the finished shaft, or in quantities which will impede the progress of the sinking contractor, water rings are cut in the rock and concreted to form a drainage channel around the shaft. The general design is as shown in Fig. 5. Rings are concreted to a column pipe leading to the sump in the pipe compartment of the shaft. Strainer plates are placed on each side of the outlet pipe and the lagging left off so that they can be entered for cleaning from the cages or stairway. In air compartments they are of course sheeted over. Where possible, splash boards are placed to deflect the water dripping from the timbers into the rings. The concrete in a ring is placed with a grade of about 8 inches in a shaft 30 feet long to give a good drain toward the outlet pipe. The general value and the location of rings are too often lost sight of. If the shaft is located in low ground where it is liable to influx of surface water, a ring should be placed in the first suitable rock ledge

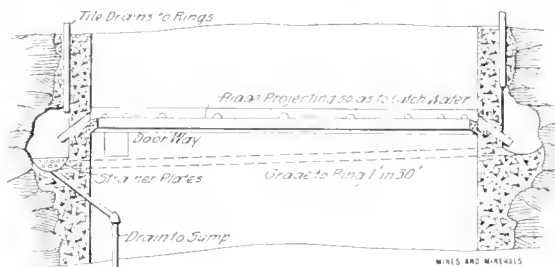

FIG. 5

before the water gets a chance to run through the lagging and drip into the shaft. A ring should be located just above the coal if there is water at all so as to have as dry a shaft bottom as possible. On the first suitable rock in the shaft a concrete coping wall should be built as a foundation for the permanent head-frame and as a retaining wall to withstand the earth pressure. Shaft-bottom timbering

at the coal is designed for cage landers and bumpers and for the admission of the longest rail length to be used in the mine.

The cry for a more permanent and fireproof construction turned engineers to concrete as a lining, and in May, 1903, contract was let for the first concrete-lined coal mine shafts in this country. These shafts were sunk for the United States Coal and Coke Co. at Tug

River, W. Va., and were practically elliptical in shape. The next few shafts constructed were also elliptical in shape except one or two which were a combination of a rectangle and an ellipse, practically a rectangle with arched sides and ends as shown in Fig. 6. About two years ago designers grew bolder and started the construction of a pair of shafts with only the ends arched, the sides being straight to give a surface parallel to the ends of the cages. Nearly all the deeper concrete-lined shafts have since been constructed along these general lines. The excavation is practically elliptical and this is of course a distinct advantage. Figuring the sides as beams the greatest thickness is as it should be, in the center, and since the ends are arched and the thrusts are directed to the ends of the sides, that is the beams, the assumption of the strains seems to be reasonable. In a good many shafts steel reinforcement has been used in the lining in soft rock strata, for engineers are not sure of their theory. The

linings are not figured for hydrostatic pressure, and drains conducting the water to rings are usually put in. These are made of farm tile with broken stone packed around them and protected from the concrete by tar paper or corrugated iron. However, it is possible by means of diamond drill holes always kept below the bottom of the shaft to foresee excessive water troubles in most cases. Grout machines are attached to pipes driven tightly in the holes and cement grout forced into the fissures under great pressure. By this process of cementation the crevices are filled and the ground made solid and dry for sinking. In sinking in a wet country it would seem a wise move to figure on such a method at the start, for not only will the shaft be dry, but money saved in pumping the shaft sump during the life of the mine will be very great. This method has been tried only once in this country to the writer's knowledge, but it was as successful here as it has been in Europe. The concrete-lined shafts used for the downtake and uptake shafts for the huge syphons that pass under valleys and rivers for the new Catskill aqueduct, which is being built to supply increased demands of New York City, are circular in shape. With the concrete in compression, when the aqueduct is empty, by virtue of the arch principle it is possible to subject the lining to considerable rock pressure. Drains made of pieces of wrought-iron pipe and leading from the rock to the concrete forms are laid in the concrete at the wet stratum and the water allowed to run into the shaft. When the shaft is finished grout machines are attached to the drains and cement is pumped into the crevices in the rock. When the grout has set the hole is plugged. This same method is used in the tunnels of the aqueduct.

The best proportions for the concrete mixture for linings are one part of cement mixed with two parts of sand and four parts of gravel or broken stone. If the excavation could be cut accurately

to line like cheese, the cost of lining with concrete would be no more than with timber. But unfortunately, may be fortunately, we do not sink through cheese, and the actual concrete to be placed is about two and one-half times the theoretical quantity, due to slippages and the scaling of shattered rock from the rib, a very thorough performance of the latter job being especially essential with concrete lining. In fact it is more than probable that the natural tendency of soft strata to break back due to disintegration and slipping and the consequent thick lining at these points is the reason there are no failures of lining reported. It is customary to imbed one-man stone in the concrete back of the theoretical lines, as being a cheaper, yet substantial form of back filling. If all the minute air bubbles could be removed from the concrete it would be absolutely impervious to water, but this is rarely possible. The concrete should be mixed fairly wet and made in comparatively thin layers. It should be spaded well, for only by thorough spading can air bubbles be worked out.

Opinions vary greatly regarding the buntuns for concrete-lined shafts, and cross-sections of several that are in use are shown in Fig. 7. By far the cheapest and certainly a most satisfactory form is the timber buntun. The all-steel buntun has many advocates and is used a great deal, but the arguments against it are many. In the first place, it costs about four times as much per foot as the timber buntun, if only a 35-pound per foot section is used. Secondly, it is necessary to allow for corrosion, and for this a very heavy section is required. One company in West Virginia uses a center buntun section weighing about 96 pounds per foot. If a steel buntun is decided on the H section is probably the best made, since it is ideal in shape and rolled in a manner to give an even stress throughout the section. In the next place, the procuring of new steel buntuns in case of wreck takes longer than the procuring of timber. The strongest argument for the use of the steel buntun is its fireproof qualities; but whether a fire sufficient to burn out timber buntuns wet from shaft water and from cage drippings and spaced 5 feet apart in a concrete lining, would not warp and twist steel buntuns until they would have to be replaced is a question for the mine fire expert. A reinforced-concrete buntun seems ideal in a good many ways and its cost would be no more than an all-steel buntun of standard section. A small steel I beam or H beam wrapped with expanded metal and encased in concrete seems a good design. Buntuns of this type are being placed in some Indiana shafts now in the course of construction. If necessary to place a partition in the concrete-lined shaft, tongued-and-grooved pine sheeting is spiked

to the buntuns if they are of timber. In some cases a reinforced-concrete partition wall has been built making the shaft absolutely fireproof. The new state mining law of Illinois specifies now that the shaft in all new propositions shall be of entirely fireproof construction, and we can look for many improvements in shaft details from that section.

Guides for concrete-lined shafts are of practically the same form as for timbered shafts. One company in the South has made a radical departure in using a steel H section with cast-steel sawtooth racks riveted to the web on either side of each guide to engage safety dogs in case of emergency. Besides costing many times as much as timber guides it does not seem to be as practicable. Certainly steel dogs of a cage that is starting to fall, gripping into timber guides, will cause less damage than steel dogs thrown into the teeth of a steel rack. The dynamic force of a loaded cage dropping only a few feet is terrific and if stopped suddenly, as with a steel rack, something is going to break. The rings in concrete-lined

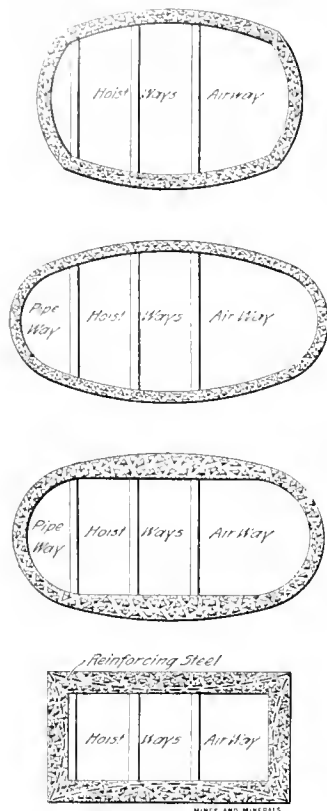

FIG. 6

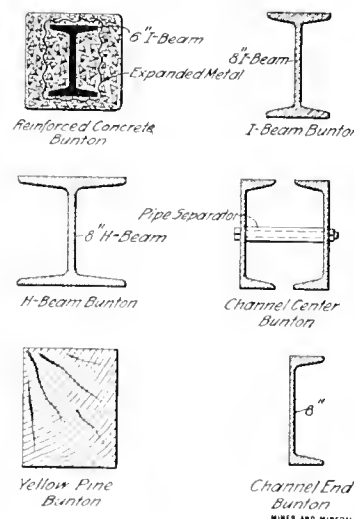

FIG. 7

shafts are the same as in timbered shafts, being practically catch basins running around and behind the concrete lining and piped to the sump.

Concrete-lined shafts permit of exceptionally good arching plans for the shaft bottom, quarter bends in the concrete making ideal air-courses and providing ample space for handling rails from the cages into the mine. The nature of the roof will, of course, determine the thickness of the arches and the necessity for reinforcement.

A description of the usual methods of sinking in rock may be informative to some. The earth surface is excavated, dimensions being ample to allow for concrete coping and head-frame foundations. Rock drills operated by compressed air cut lines of holes at angles to blast out a sump. The holes are usually 8, 10, or 12 feet deep according to the size of the shaft. Pumps are then taken out of the shaft and the holes fired by battery or dynamo. The shooting of the sump fills the shaft with muck to a depth of 4 or 5 feet. As soon as the powder smoke permits, pumps are lowered and connected, and all hands muck at one end to find the solid, when the drills are again set up and the first bench drilled. Enough men are employed to completely muck the sump by the time the first bench is drilled and loaded. As soon as the bench is fired and the pumps are again working, the men muck for the last bench, which is drilled, fired and mucked. The process is then repeated. Of course there are many hitches in this scheme at times, crevices in the rock and soft strata often causing shots to break poorly, expending their force in strata beneath the bottom of the shaft. Ten-foot holes usually pull from 6 to 9 feet of shaft depending on the nature of the rock. The wise superintendent always has muck for the muckers and the shift is regulated with this in mind. The nature of the ground determines the distance the sinking can proceed before it is necessary to stop to timber. Bearing timbers are placed in hitches cut in the rock directly in line with the buntons. The kind of rock determines the depth of the hitches. These bearing timbers, usually called dead logs, are lined, leveled, and blocked, and a set of timber placed on these as a foundation and wedged to line. The timbering is then built up and lagged. The space behind the lagging, which is spiked to the sets, is filled with saw-mill slabs or other suitable packing, to keep loose rock from falling behind the timbers. Practically the same method of lining is followed when a shaft is to be concreted. A platform is built on dead logs hitched in the ribs and the forms started with the platform as a bulkhead. The forms are usually made in slabs as high as the distance from center to center of the buntons, which are concreted in place.

There is no doubt but that the concrete-lined shaft is the ideal form, the question of its adoption in place of the timber lined depending on the life of the mine and the policy of the company. Long leaf yellow pine and white oak will last from 20 to 25 years in a shaft. If the coal will last longer than this, the lining should be of concrete, for not only will retimbering cost more than the excess cost of concrete at the time of sinking, but the shut-down of a mine for repairs in a busy season would soon prove a rapid money loser. Again, fire may hasten the retimbering time and fire shows no partiality for dull seasons. However, doubts regarding the advisability of sinking concrete-lined shafts are rapidly disappearing, and in nearly all the large propositions lately this type has been specified. Where the vein of coal is known its ultimate economy is unquestioned.

The question of speed in sinking is of great importance to the operator. With the interest charges amounting to several hundred

dollars a day on a high-priced coal field, it is readily seen that the speedy contractor is the one to employ at almost any reasonable figure. An average of 70 feet sunk and lined is a fair monthly rate of progress in comparatively dry shafts. This is often exceeded and just lately 183 feet were sunk in 27 working days in hard granite on the New York aqueduct at Storm King, N. Y. Such progress has never been made before in this country in hard rock, although very good records have been made in the soft shales in Kansas and in southern Illinois. In South Africa, 213.5 feet were sunk in one month in the New Kleinfontein shaft on the Rand. This work was carried on by three 8-hour shifts working for 31 days and as far as is known is the world's record. It must be understood that these records are only made in dry shafts. In wet holes the speed rapidly decreases as the water increases. With 150 gallons per minute 50 feet advance per month is fair; with 500 gallons per minute, 25 feet per month is good sinking. Since sinking through increased quantities of water causes an extra cost, the equity of the water clause is readily seen. This clause provides for extra payment for excavation done under conditions which necessitate the pumping of certain specified quantities of water. The contractor naturally bids lower when a water clause is included in the contract, for he does not figure on nearly so great a risk when the greatest danger, water, is taken from the list of contingencies.

In conclusion, a very brief discussion of a few points which are very necessary for the constructor of the new plant for which shafts are to be sunk may be of interest to some. By far the most important is the starting of the shafts at the proper time in reference to the other contracts for the plant. The power plant should be completed by the time the shafts are bottomed. The engines should be ready to operate and even the head-frame can be built while the contractor is sinking, by roofing and siding the contractor's temporary head-frame. If all shafts were dry, these points would not be vital; but since the dry shaft is so rare, it is either a question of letting the holes fill up with water or renting the contractor's equipment. This may seem an easy matter to fix at the start of the plant, but it may surprise some to know that in only about one case out of four has it happened that the coal company was ready to take over and operate the shaft with its own machinery. It costs no more to have engines set up a month before the shafts are bottomed than a month afterwards, as far as the engines are concerned, and the money saved by not having

to pump a drowned shaft, or by not renting boilers, engines, and pumps, will equal the profit on a good many cars of coal. The disposition of the muck from the shaft is another point that can make or lose money for the coal company. Tipple piers, engine foundations, fan foundations, etc., should be built as soon as the shafts are started and the muck from the shafts filled in around them to grade. Distributing the spoil at random and then excavating for foundations through the rock dump is done surprisingly often. The sinking contractor can even fill for the railroad for 300 or 400 feet on each side of the shaft at little extra cost, yet this is very often lost sight of and good costly fill borrowed. A judicious use of excess spoil from shafts in grading will often turn a rough hilly location into an admirable plant layout, convenient for mine-car repair tracks, mine buildings, etc., at a very small cost. In most cases shaft muck is an asset and not a spoil.

The connection between buntons and cage guides is shown in Fig. 1. In the third figure from the right the two guides are fastened each side of the buntun by means of countersunk bolts and a channel iron. In the second an angle iron forms a rigid connection.

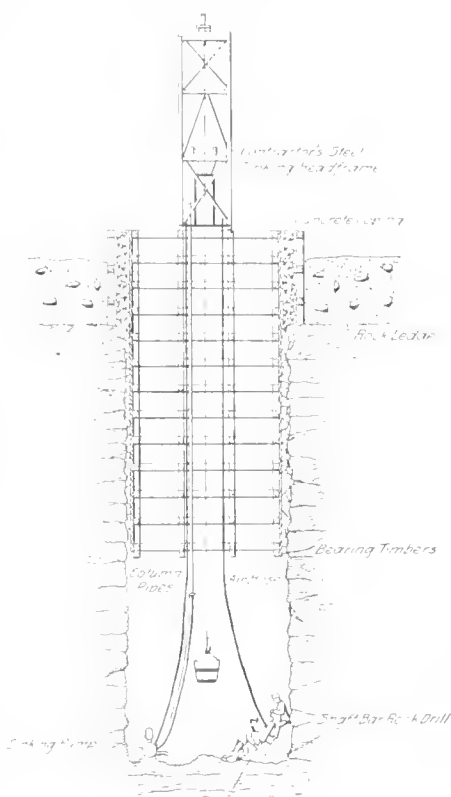

MINES AND MINERALS
Fig. 8

Victor-American Fuel Co.'s Instruction Car

Equipped for Instruction in Rescue Work and to Furnish Apparatus and Aid in Time of Need

The Victor-American Fuel Co.'s instruction car, a term which is preferable to the much-abused designation, "Rescue Car," is permanently stationed at the Hastings, Colo., mine of the company, in charge of Mr. D. H. Reese, to whom, and Mr. G. C. Headley, of the Colorado & Southeastern Railroad, we are indebted for sketches and descriptions.

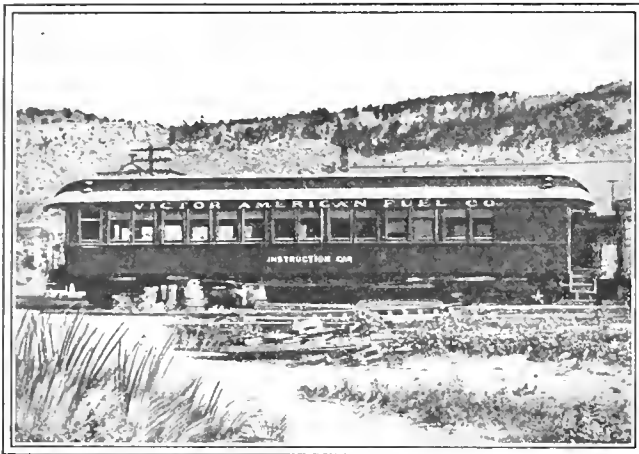

FIG. 1. INSTRUCTION CAR, VICTOR-AMERICAN FUEL CO.

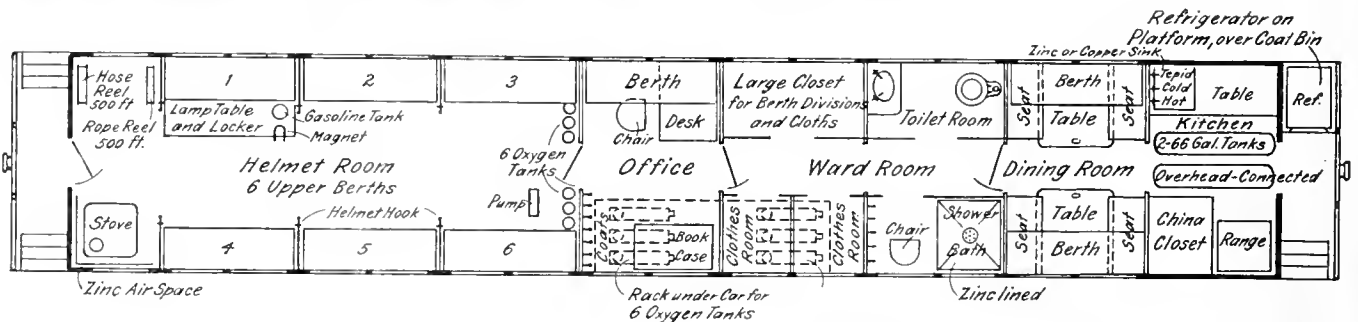

FIG. 2. PLAN OF INSTRUCTION CAR

The car, a former Pullman, as are also those of the United States Bureau of Mines, was remodeled at the shops of the C. & S. E. R. R., under supervision of Mr. Headley, and in many ways is a marked advance upon what may be called the "Government" type of car. One of the most noticeable improvements is the entire absence of the ordinary stuffy and uncleanly Pullman berth equipment. Zinc or linoleum floor covering is used throughout, all lockers and cases for maps, books, equipment, etc., are larger than ordinary and the use of a light maple interior finish gives the car a bright and cheerful appearance.

The general floor plan of the car is shown in Fig. 2. The helmet room is 21 feet long, contains six oxygen tanks in racks, and the necessary pumps. There is also a reel with 500 feet of fire hose and another with the same length of rope. In one corner is a stove for heating when not on the road, although the car is, of course, equipped for steam heating in ordinary train service and at such of the company's mines where steam is available. In this compartment are six upper berths, three on each side. Under the berths are the boxes or racks for the helmets, of which there are six, five of the Westphalia and one of the Proto type, together with one of Doctor Brat's oxygen reviving apparatus. In this room also are 10 large electric lamps of the storage battery type of about 4 candlepower each, and six flash lights with the necessary extra dry batteries.

In one corner is the locker for safety lamps, of which 30 of the Wolf gasoline-burning type are in stock prepared for immediate use. The safety-lamp locker can accommodate 72 lamps in four rows of 18 each, is zinc lined, and partitioned so that the lamps may not tip over. The top of the box has a raised rim, is covered with zinc, and forms a pan in which the lamps are cleaned and filled from a gasoline tank permanently attached to one end of the box. The magnet for locking the lamps is on this box.

The second compartment has on one side the office desk and other necessary equipment, above which is a berth, and on the opposite side a bookcase and small coat room. Here are maps of all the company's mines, which are kept up to date at each quarterly posting. There is also a locker for helmet and lamp parts.

The third compartment, 5 feet 11 inches long, has on one side a large closet for the stowing of berth partitions and bedding and on the other two separate clothes closets.

The fourth compartment is 5 feet 10 inches long, one side being taken up with the toilet facilities and the other with a shower bath, clothes hooks, etc. The shower bath is zinc lined and has both hot- and cold-water equipment, an extra cold-water tank being placed overhead and connected with the hot-water heating system.

The fifth compartment, or dining room, is 5 feet 11 inches long and is equipped with upper and lower berths (four in all) and with removable tables.

The sixth and last compartment, the kitchen, is 5 feet 8½ inches long. The floor is covered with sheet zinc. There are two overhead water tanks of 66 gallons capacity each and one cold-water tank of 30 gallons. The range is set in a sheet-



FIG. 3. HASTINGS, COLO., FIRST-AID TEAM

metal air chamber and the kitchen is provided with the usual china closets, tables, etc., hot- and cold-water taps, and dish-washing sink.

On the platform is a four-compartment refrigerator holding 700 pounds of ice, underneath which is a coal bin.

The car is lighted throughout by improved oil lamps and is wired for electric lamps, which are used whenever possible. The helmet room is smoke tight to permit of training in formaldehyde and other gases. All doors, except those leading

to the platforms and to the helmet room are hung on double-acting swing hinges.

Under the car is a "possum belly" with racks for six additional oxygen tanks as well as potash cartridges, brattice cloth, and heavy tools.

Mr. Reese is constantly with the car, which is always ready and equipped for instant service. There are three regularly-trained helmet crews at the Hastings mine who accompany the car as volunteers in event of accident. These crews consist of five men each, and are captained by Mr. D. H. Reese (in charge of the car), Mr. A. E. Thompson, and Mr. H. Winters.

The other mines of the company have their own helmet crews, and it is the intention, in event of an accident at a mine with the workings of which the Hastings men are naturally not familiar, to drop one of them (the Hastings men) and take a local man in his place by reason of his knowledge of his own mine.

First-aid-to-the-injured and helmet instructions are held every Saturday and Sunday, the company sending two men from more distant mines each week, who, with three men from Hastings, fill out a team to its full complement of five members. The helmet training is carried on in an abandoned mine which is so full of black damp that the safety lamps go out within 5 feet of the drift mouth. In this atmosphere the men work under actual accident conditions and have become very proficient in all departments.

來 來

Crushing Coal for Boiler Use

A few years ago coal consumers objected to receiving run-of-mine coal, in fact any coal that contained less than 80 per cent. lump. Much fine coal therefore was mixed with bone and rock and thrown on the dump where in the course of time it generally took fire and became a further nuisance. From the fact that piles of bony and dirty coal took fire and burned, it was naturally assumed

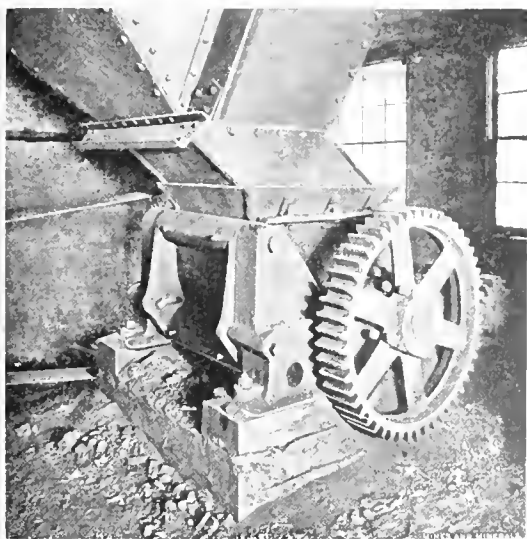

FIG. 1. SINGLE-ROLL CRUSHER

that such coal would burn under boilers. The economical factors embraced in this supposition were that the dirty coal had cost money to mine, haul and waste, and if it could be used under boilers it would release that much good coal for market, thus making a twofold saving

The first engineer that approached a mine manager to prevent this almost criminal waste of fuel, was met with the question, "What business is it of yours?" Matters have greatly changed since then and it is now the custom at those mines which have large boiler plants to install a pair of Cornish rolls and break the material

to a size that can be fed to a mechanical stoker. There are certain matters in connection with Cornish rolls which are fairly well known, among them being the necessity for uniform feeding to prevent their being flooded and choked.

To overcome this feature and to do away with the automatic feeder that accompanies Cornish rolls, the Pocahontas Consolidated Collieries Co., at Switchback, McDowell County, W. Va., installed the Jeffrey single roll crusher shown in Fig. 1, and which after several months trial seems to be giving satisfaction. The crusher consists of a toothed roll shown in Fig. 2, mounted on a shaft, and a breaker plate. A hopper, housing, and suitable gear-wheels com-

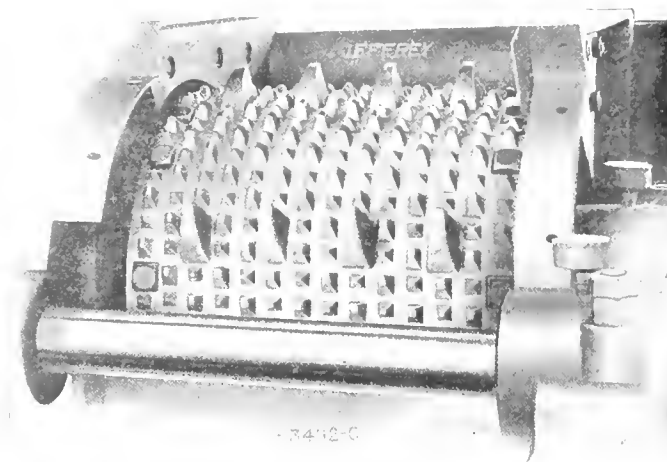

FIG. 2

plete the mechanism. The hopper is so arranged that the coal may be dumped into it from the mine car, the single roll acting as a feeder. The drum of the roll is covered by segments which have varying lengths of teeth. The long hooked teeth act as feeders by gripping the larger pieces of coal or bone and breaking them to a size that will pass through the crusher. The breaker plate is concave. At its upper edge it is hinged to the frame; at its lower edge it is held in position by two rolls which also permit the adjustment of the breaker plate shoe and the surface of the roll to furnish different sized products.

The capacity of the roll shown is given as 160 tons per hour with an expenditure of 17 horsepower, but this capacity would not apply to every kind of coal because of difference in hardness.

A rule of thumb for determining the capacity of bituminous coal crushers is to compute the capacity at one-third the ribbon. By ribbon is meant the area of space between the rolls multiplied by their peripheral speed. Soft, friable coal like that in the Pocahontas fields can be reduced by a simple pressure, and the gap between the rolls may be greater for the same reduction than obtains with a harder, tougher coal, such as Illinois coal. The capacity of the machine would therefore be greater with the softer than with the harder coal.

There is one feature in connection with the single roll crusher which is new, so far as the writer is aware, and will appeal to those who have had hammers, picks, drills, etc., pass into, break, or stop their rolls. The driving pulley is not keyed to the shaft but is mounted on a separate hub which is driven through a set of wooden pins inserted in holes in the pulley. When any undue strain comes on the machine from any cause these wooden pins shear off and the roll stops while the pulley keeps on revolving, thus forming an efficient safety device. A pair of heavy springs are placed on the tension rod, which under ordinary working conditions do not move, but when an undue pressure comes on the breaker plate they act as a cushion, giving way slightly, taking up the inertia of the parts, and allowing time for the pins to shear without breaking the more important elements of the machine.

來	Correspondence	來
---	-----------------------	---

Siphon

Editor Mines and Minerals:

SIR:—We have a large pond of water in a mine which, if possible, we want to remove by a siphon line 3 inches in diameter. From the bottom of the pond to the summit, a distance of 1,000 feet, there is a rise of 24 feet and one right-angled curve. From the summit to the lowest discharge point the distance is 550 feet and the fall 34.66 feet. Will the siphon work under such conditions?

Tracy City, Tenn.

H. L. G.

Coal Dust Explosions and Air

Editor Mines and Minerals:

SIR:—My attention has just been called to a communication from Mr. John Verner, State Mine Inspector of Iowa, published in the September issue of MINES AND MINERALS, in which he replies to comments by myself appearing in the July number, relating to an article on coal-dust explosions published by him in the May number.

The subject is one of very great interest and importance and one which has been too little studied to permit of much generalization. I am glad to find that the opinions of Mr. Verner and myself are really not very divergent, and that apparent differences result more from different uses of language than from fundamentally different conceptions of facts. There is one point, however, on which the opinions are importantly different. Mr. Verner believes that the amount of air is the principal factor in determining the explosiveness of a mixture of coal dust and air. This, in my opinion, is commonly not the case. I believe that it is more often the explosive dust which is deficient in quantity than the air. It is possible for dust to be present in too great quantities, just as it is possible that methane may be present in too great quantities to be explosive, but I believe that both conditions are rare.

It must be noted that not all coal dust is readily explosive and that its explosiveness depends largely upon the fineness of the dust and its contents of volatile combustible matter. It is possible, therefore, for the total quantity of dust to be large, though the readily explosive dust may be present in only small quantities, because most of the dust may be comparatively coarse or because the character of the coal is such that the dust is not readily inflammable. The conditions which I previously stated as necessary for explosiveness are, first an explosive dust, second the suspension of a sufficient quantity of it in the air. These conditions, I think, are rarely met, because most of the dust is either not readily combustible or is not sufficiently fine to be readily suspended in the air.

I wish to refer to a few points mentioned by Mr. Verner. He quotes the testimony of Doctor Payne regarding the explosion at the Monongah mines, in which it is stated that the force of the explosion would have been much greater if there had been sufficient air for complete combustion. If this is true it hardly seems to support the contention of Mr. Verner that a large supply of air is necessary for explosion to be possible. On the other hand, it indicates that an explosion may occur when there is not enough air to burn all of the dust. However, I greatly doubt the possibility of accurately computing the force that would have been developed with a supply of air sufficient to burn all of the volatile combustible matter of the dust. The extent to which this would be consumed in any case depends largely upon the size of the particles of coal. Very minute particles would probably be completely coked, and in the presence of sufficient oxygen, the combustible matter distilled would be burned. Large particles would probably be incompletely coked and only that part of the combustible matter that had been gasified would be burned. The amount of coal taking part in the explosion would also depend upon the amount suspended in the air and it would be very dif-

icult and probably impossible to determine this. An analysis of the mine air immediately after the explosion would have determined whether a larger supply of air would have resulted in the burning of more of the dust, the presence of carbon monoxide indicating insufficient air, but I think no analysis was made.

The reference to the explosion in mine No. 18 of the Dering Coal Co. states that the secondary explosions occurred about 2 hours after the main explosion and suggest to me the explanation that these were not due to coal dust but to gases distilled from heated coal or to carbon monoxide resulting from the incomplete combustion of coal. A mine fire is mentioned, and mine fires almost always produce such gases, as was the case in the explosions at Hanna, Wyo., and Zeigler, Ill.

The statement is also made that old mines suffer less frequently from dust explosions than new mines. I do not know whether this is a general fact and do not care to offer a suggestion without further knowledge of the facts, but suggest that Mr. Verner's conclusion that this is due to a large supply of air in the partly developed mines is not necessarily the only explanation. It is true, however, that suspension of the dust in air is necessary to the explosion, and that the dust is kept in suspension better with a rapid air-current than with a low one. The result is that the ratio between the air supply and the dust in suspension is really reduced.

He refers to the fact that survivors of some dust explosions have noticed a blast of air blowing toward the place of combustion and immediately preceding the passage of the explosion wave. This was evidently one of the phenomena of the explosion itself and not a condition existing before the explosion. It will be noticed that this really did not increase the quantity of air in the mine and that it did not exist before the beginning of the explosion. It is known that the expansion of air caused by the heat of combustion is followed by contraction as the air cools and the water vapor condenses, and that there are districts of comparatively great violence separated by districts of comparative inactivity. I think it probable that these survivors owed their escape to the fact that they occupied positions in which the force of the explosion was slight and that the blast toward the flame was due to contraction of the cooling air at a point where the action had been more violent. Such a blast would aid the progress of the explosion by stirring up the dust and not by increasing the total quantity of air present.

A large number of experiments on the subject of dust explosion have been made at the University of Kansas, and an account of these, with a great deal of other matter, will appear in the forthcoming Volume X of the Reports of the State Geological Survey of Kansas.

My reason for making these comments is the fact that the belief that the quantity of air alone is the determining factor in the explosiveness of dust might lead to the neglect of certain precautions. On the other hand, the belief that the most important factor is the presence of an explosive dust will lead to efforts to decrease the quantity or explosiveness of the dust, which I believe is necessary to safety.

C. M. Young

Lawrence, Kans.

Car Spotter

Editor Mines and Minerals:

SIR:—At our mine we are loading the standard form, 100,000-pound capacity, steel hoppers, the grade under the tippie being seven-tenths of 1 per cent. In order to stop the cars properly they should be dropped 4 feet at each move. It has been our custom to use a pinch bar for starting the cars, but the momentum thus acquired is so great that they commonly run farther than the required 4 feet and have to be pinched back up hill. They may generally be stopped at the proper place by means of a heavy pine cross-tie. Timber with us is very expensive and the ties soon wear out. We would be glad to know if any of your readers is acquainted with some simple device which, under our conditions, will start a car and stop it at the required point.

A. C. G.

Coal Mining Notes

Lake Coal Shipments.—The shipments of soft coal for October, 1911, 2,162,845 short tons, were on a lower scale than in October, 1910, when 2,554,114 short tons were shipped. The shipments for the 10 months of the present year, 14,986,653 short tons, of which over one-half proceeded from Ashtubula and Toledo, likewise fell short of the 1910 shipments of 16,251,819 short tons. Over 95 per cent. of this coal moved to Lake Superior and Lake Michigan destinations, the principal receiving ports, Duluth-Superior and Milwaukee claiming about 64 per cent. of the total receipts of this article.

October shipments of hard coal, 459,861 short tons, likewise proceeded on a smaller scale than in 1910, though the 10 months' figures, 3,722,741 short tons, are larger than those of a year ago. The main destinations of this coal were Duluth-Superior, Milwaukee, and Chicago, the quantities unloaded at Lake Michigan ports exceeding by far those received at Lake Superior destinations.

B. S.

Explosion at the Adrian Mine.—On November 9, 1911, an explosion occurred in the Adrian mine of the Rochester & Pittsburg Coal and Iron Co., DeLancey, Jefferson County, Pa., which caused the death of eight men. This is known as a gaseous mine, but the direct cause of the gas explosion is unknown. Two of the victims were killed by the force of the explosion, the remaining six being overcome by afterdamp, although $\frac{3}{4}$ mile away from the explosion.

Carbide Lamps in Ohio Mines.—George Harrison, Chief Inspector of Mines in Ohio has had so many inquiries relative to the law governing the illuminants in mines of his state he has had printed a pamphlet on the subject. He states in this pamphlet: "The law in our state defines the kind and quality of illuminants to be used in the mines: A pure animal or vegetable oil, also a paraffin wax with not to exceed 4 per cent. of oil or moisture and also electric lights under certain circumstances. Acetylene gas or carbide is not provided for, and in consequence its use is prohibited."

Coal Land Statistics.—The Bureau of the Census, Department of Commerce and Labor, Washington, D. C., furnishes the following interesting information on coal land controlled and held under lease in the principal coal-producing states:

COAL LAND STATISTICS

	Acres Controlled		Acres Owned		Acres Held Under Lease	
	1909	1889	1909	1889	1909	1889
United States	6,906,088	1,711,491	1,782,170	1,248,373	2,134,893	493,118
Anthracite	274,870	213,938	183,144	107,362	102,701	107,196
Bituminous	6,631,218	1,526,953	4,599,026	1,141,011	2,032,192	385,922
Pennsylvania	1,927,829	411,574	1,509,425	240,093	429,379	204,681
Anthracite	274,010	213,938	183,044	107,282	101,941	106,656
Bituminous	1,653,819	239,836	1,326,381	132,811	327,438	98,025
West Virginia	1,147,527	107,521	590,885	61,531	556,642	45,990
Alabama	612,026	222,749	538,122	216,129	73,904	6,620
Illinois	553,711	191,740	398,090	161,468	155,621	30,272
Ohio	498,113	104,898	260,423	66,697	147,990	38,201
Indiana	141,272	21,898	104,938	15,785	36,334	9,023

French Mine Explosion.—Twenty-six men were killed by an explosion in the Bardot coal mine, St. Etienne, France, October 16, 1911. The men were engaged under the supervision of an engineer in fighting a fire which had been burning in one part of the mine for 24 hours.

Anthracite Mining Statistics.—In addition to the anthracite producers of Pennsylvania there were three operators in Colorado and New Mexico, reporting a total capital investment of \$215,000, employing 250 persons, with total expenses of about \$220,000, and a production of approximately 80,000 tons of anthracite valued at about \$230,000 at the mines. In 1889 these states produced 54,000 tons of anthracite, an increase of 48 per cent. in the output in 1909.

PENNSYLVANIA ANTHRACITE STATISTICS

	Census	
	1909	1889
Number of operators	192	(*)
Number of mines	422	392
Capital invested	\$246,700,000	\$161,800,000
Total expenses	\$139,374,000	\$ 61,110,000
Salaries and wages	\$ 96,926,000	\$ 39,279,000
Salaries	\$ 4,583,000	\$ 1,510,000
Wages	\$ 92,343,000	\$ 37,769,000
Cost of materials used	\$ 26,724,000	\$ 10,822,000
Miscellaneous expenses	\$ 15,724,000	\$ 11,009,000
Deduct charges to miners for explosive oil, and blacksmithing	\$ 4,884,000	
Net expenses	\$134,490,000	
Products:		
Total production, tons	72,300,000	40,700,000
Total production, value at mines	\$149,000,000	(*)
Total marketed, tons	64,600,000	37,100,000
Total marketed, value at mines	\$116,000,000	\$65,700,000
Acreage of mineral land controlled by operators (total)	274,010†	213,938
Owned	183,044	107,282
Leased	101,941	106,656
Number of employees:		
Salaried officials and clerks	4,308	1,828
Average number of wage earners	169,000	122,000
Primary horsepower	675,000	(*)

* Not reported.

† Excluding 10,975 acres reported twice in total for "owned" and "held under lease."

Vanishing Coal Supplies.—The dwindling visible coal supplies of the world are engaging the attention of the governments of most countries where coal is found. Sir William Ramsay, the English scientist, startled the British Association some weeks ago by saying in his presidential address that the coal supply in the United Kingdom would not last 175 years, if the wasteful use of material is not promptly checked.

The German technical journal *Kohle und Erz*, which has made a general survey of the world's coal production, states that, barring the United States, and perhaps North China, Germany is still the richest coal-bearing country. America, with its huge production of nearly half a milliard tons a year, is, it says, rapidly approaching exhaustion, and the same may be said of the coal fields in the United Kingdom, where the production is also high and must end in the

giving out of the supply in 150 or 200 years, at all events in the North of England, Northumberland, and Durham. The other English sources may last half a century longer.

The first mines that will have to close down will be those of central France and Bohemia, which only have 100 years more to live. The north of France and the Saarbrucken basin in western Germany come next with a life of between 400 and 500 years. Still better situated are the Belgian and Westphalian coal regions and the fields in the Austrian and Russian parts of Upper Silesia, which may reckon on an uninterrupted output for the next 800 years.

Prussian Silesia is safe for another 1,000 years or more. Nature has made here vast deposits of pure carbon, with lodes of an average

thickness of 40 feet. Some of them are 60 feet thick, so that coal consumers may take heart of grace.

Coal Men and American Mining Congress.—Perhaps never before has there been such a gathering of coal and metal mining men as intermingled at the third-day session of the American Mining Congress in Chicago. It has been predicted that unless the bituminous coal operators could get a fair margin of profit for their product the industry would sooner or later go into bankruptcy and involve the entire commercial fabric in a panic. The operators have been seeking some national organization with which they might affiliate and through it conduct an educational campaign that would relieve the present conditions. The success of the American Mining Congress as an organization of metal-mining men, the rapidly increasing sphere of its influence, and the work it has accomplished, made a strong appeal to them, and they made a vigorous campaign to have the recent convention held in Chicago, that a statement of the conditions surrounding the coal industry might be made and the aid of the Congress enlisted. Having much in common, the Westerners and the operators fraternized during the early days of the session, and, following the presentation of a paper prepared jointly by B. F. Bush, president of the Missouri Pacific Railroad, and A. J. Moorshead, president and general manager of the Madison Coal Corporation, in which the position of the coal men was fully outlined, the metal miners extended the hand of friendship, and the operators at a meeting among themselves, at which there were representatives of 10 or more operators' associations, passed resolutions confirming their decision to affiliate.

The paper by Messrs. Bush and Moorshead was based upon the replies to a list of questions sent to 2,300 coal operators by the Congress, in which were asked the cost of production, selling price, and the additional expense which will be entailed in order to meet the demand of the public for greater protection to life and the conservation of resources. It was shown that the coal operators are absorbing as losses in excess of \$58,500,000 per annum, or slightly in excess of 14 cents per ton. Overproduction was assigned as the cause of this deplorable condition.

Hoisting Record in Illinois.—Secretary David Ross, of the Bureau of Labor Statistics, Springfield, Ill., is in receipt of the following communication from T. G. Hebenstreit, superintendent of the New Staunton Coal Co., Livingston, Ill., relative to the tonnage of that mine: "Livingston mine hoisted during the last half of October 54,649½ tons, working 13½ days, making an average of 4,029 tons per day. Our record hoist September 29 is 4,265 tons, making 1,492 dumps, or hoists, loading 105 railroad cars in 8 hours. The above for your information. We claim the record for the state."

採 采

Book Review

James C. Mills has written a book entitled "SEARCHLIGHTS ON SOME AMERICAN INDUSTRIES." It consists of stories on lumber, salt, sugar, paper, rubber, leather, molding, graphite, and sightless workers. History, the writer states, "deals with the barbaric and takes no account of a nation's intellectual development, or its industrial progress or commercial expansion." "In this enlightened age the life and evolution of the American people lie in their quiet, peaceful, and productive efforts, and in the thoughtful conduct of their affairs." While the book is general, and therefore unsuitable for use as technical literature, nevertheless the stories of the various industries are good reading. It is possible that Mr. Mills has set in vibration a new chord in the harmony of school education, for literature of this class is far better than the *Lady of the Lake*, *The Last Days of Pompeii*, or similar stuff that means nothing to our children. The price of this book is \$1.50 net. A. C. McClurg, Chicago, publishers.

THE COPPER HANDBOOK. The 10th edition of Horace J. Stevens' *Copper Handbook*, is more replete with information dealing with matters strictly pertaining to the copper industry than any heretofore published. Since its inception the *Copper Handbook* has

grown from 328 pages to 1,902 pages, and the last edition contains eight times as much information as the first edition. The *Handbook* is used by editors, engineers, investors, and those interested in copper. It is of especial importance to engineers who contemplate a trip to a special ore district, as it gives them a natural and reliable insight to what has been done in the section to be visited. There are 11 chapters covering the History, Geology, Chemistry, Mining, Milling, Hydrometallurgy, Pyrometallurgy, Alloys, Brands, Grades, and Uses of Copper. There are 10 chapters dealing with Copper Deposits in the United States, Canada, and Newfoundland, Mexico, Central America, the Antilles, South America, Europe, Africa, Asia, Australia, and Oceania. In addition there are chapters on the following subjects: Substitutes for Copper, Glossary of Mining Terms, Copper Statistics, and of course a list of the copper mines of the world, on which depends the greatest value of the book. The price is \$5 and may be had from Horace J. Stevens, Houghton, Mich.

DETAILED COUNTY REPORT ON WIRT, ROANE, AND CALHOUN COUNTIES, W. VA., 573 pages +XX, with case of three maps—topographic, geologic, and soil—published under date of July 1, 1911, and ready for delivery in October. Besides the detailed study and description of all the rocks, minerals, soils, streams, industries, etc., found within the area, the geologic map gives also the true location of all the oil and gas pools developed up to July 1, 1911, and shows by structural contours the several anticlinal and synclinal arches, including the southern extension of the famous Burning Springs or volcano anticlinal. Price, with case of maps, postage paid by the Survey, \$2. Extra copies of geologic or topographic map, 50 cents each. Send remittances to the West Virginia Geological Survey, Morgantown, W. Va., Lock Box No. 448.

RESOURCES OF TENNESSEE. The State Geological Survey publishes a monthly magazine devoted to the description, conservation, and development of the resources of Tennessee. The first issue appeared in July, 1911, and like the subsequent issues, is nicely printed and illustrated with half-tones. All those interested in the geology and natural resources of Tennessee should write Dr. G. H. Ashley, State Geologist, Nashville, Tenn., concerning these issues.

ELECTRICAL MINING INSTALLATIONS, is the name of a pocket-sized book by P. W. Freudemacher, and published by D. Van Nostrand Co., New York. Price \$1. The book has been written especially for colliery engineers and contractors engaged in the installation of electrical plants for mining purposes. There are 12 chapters. In Chapter X the author takes up Electric Winding, and in Chapter XI follows it up with the various Electric Winding Systems. Considerable of the book is practical, and embraces the formulas and calculations necessary to explain power, outputs, etc. Chapter XII gives the special rules for the installation and use of electricity in mines, as they appear in the Coal Mines Regulation Act of Great Britain.

THE MECHANICAL WORLD'S POCKET BOOK AND YEAR BOOK FOR 1912 has been received. It contains 330 pages of reading matter, tables, etc. The chapter covering the various kinds of steam turbines has been revised and enlarged. R. M. Neilson is the writer. This makes the 25th edition of this excellent pocketbook, which can be had, postpaid, for 25 cents, by addressing Emmott & Co., Ltd., Manchester, England.

MINERS' CIRCULAR No. 5, issued by the Federal Bureau of Mines, is on "Electrical Accidents in Mines, Their Causes and Prevention." The pamphlet is by H. H. Clark, W. S. Roberts, L. C. Ilsley, and H. F. Randolph. There are eight pages of reading matter under the captions, Introduction, Definitions, Chances for Shock in Mines, General Causes of Shock, Some Direct Causes of Shock, Precautions, Explosives and Electricity, Some Suggestions, Treatment of Electric Shock, Publications on Mine Accidents and Explosives. One of the purposes of the Bureau of Mines is to make mining safer, and to this end it is suggested that Doctor Holmes send men to every mine using electricity and distribute Circular No. 5; at the same time these men can read and explain the circular to those it is intended to benefit.

Answers to Examination Questions

Questions Asked in Indiana Examinations at Terre Haute, 1911

QUES. 1.—(a) Name the different capacities in which you have been employed in coal mines.

(b) Give the name of the mine and its location in which you were employed in each capacity.

(c) What experience and qualifications, if any, should a mine boss have in order to be successful?

ANS.—(c) A mine boss in Indiana requires a certificate of competency granted by the inspector of mines to all applicants, citizens of the United States passing a satisfactory examination. To be successful a mine boss should have worked as a track layer, timberman, miner, fire boss, and assistant mine foreman, and have a technical knowledge of his work. He should have a technical knowledge of explosives, mining, mine gases, ventilation, mining machinery, and such other matters as come directly under his supervision. He should be moral, level headed, and just in his dealings with men, so as to enforce the state laws and colliery rules without regard to friendship.

QUES. 2.—(a) What is mine ventilation, and why is it necessary in coal mines?

(b) What are the laws of Indiana relative to the ventilation of coal mines?

ANS.—(a) Mine ventilation consists in sending air from outside into the mine in sufficient quantities to dilute the noxious gases that arise from the breath of men and animals, from exploded powder, decaying timber, oxidation of pyrite, oxidation of coal and from natural gas that has collected in the coal or in the rocks on either side of the coal, but particularly in the roof.

(b) Write to the State Inspector of Mines, James Epperson, Terre Haute, Ind., for a copy of the mine laws.

QUES. 3.—(a) What are the causes of mine fires?

(b) How may they be prevented?

(c) Tell when and how you would extinguish a mine fire 1,400 feet from the shaft bottom inside the last breakthrough the first east entry off the main north entry, which is the return for the air-current.

(d) A gob fire in an old abandoned room on the intake of the main air-current.

ANS.—(a) Carelessness in handling lamps; spontaneous combustion from oxidation of gob piles; steam pipes placed too close to overseasoned mine timbers; explosions of gas or fine dust; poor insulation of electric wires.

(b) By carefully handling naked lights; by not permitting gob to accumulate in damp, badly ventilated places, particularly if it contains pyrite; by placing a non-conducting substance between the steam pipe and the timber; by properly ventilating the mine and by using safety lamps in gassy mines; by moistening the air going into the mine with steam, also removing dust from haulways, by placing electric wires where they can be observed and inspected frequently.

(d) If possible, remove all coal and slack from the gob, and arrange that air from the intake be freely circulated through the room and that it be well drained.

QUES. 4.—(a) What are the state laws of Indiana relative to the use of powder, and the drilling, tamping, and firing of shots in coal mines?

(b) What steps would you take to enforce these laws, or detect persons who are violating them?

ANS.—(a) See Section 17, Mine Laws.

(b) Make the miner read the law aloud, or in case he could not read, I would read section 17 to him and see that he understood it, by watching him do his first work in the mine.

QUES. 5.—(a) What are the real dangers connected with the use of dynamite in conjunction with black powder?

(b) In using fine and coarse powder mixed?

(c) In tamping shots with dry coal dust?

ANS.—(a) Dynamite explodes much quicker than black powder, and might throw the black powder out of the hole so it would flame outside, and under certain favorable conditions propagate an explosion.

(b) The mixture not being uniform, there will be a difference in the time in the conflagration of the grains. It is possible that such a mixture might cause a blown-out shot which is dangerous in gassy or dusty mines.

(c) In tamping with dry coal dust, the dust is made finer, and is apt to ignite from the flame of the explosive and propagate an explosion.

QUES. 6.—What changes in roof, bottom, and coal seam are met when approaching a fault?

ANS.—If the fault is normal and the seam only slightly inclined, there may be an upthrow or downthrow according to which side of the fault crack the observer stands. In downthrows the fault crack is met first at the roof and coal will bend slightly downwards, show slickensides and lack cleatage. It will also be dirty if the throw is of considerable length. In case it is an upthrow the fault crack will be met first in the floor and the coal will bend slightly upwards with conditions similar to the downthrow so far as indications go. It may be possible that both the roof and floor will bend in directions opposite to the movement that has occurred.

QUES. 7.—(a) What are the duties of a mine boss as required by law?

(b) What particular points should receive the attention of the mine boss when making his daily rounds of the mine?

ANS.—See Sections 11 and 12 of the Mine Laws.

QUES. 8.—(a) A certain mine has 25,000 cubic feet of air passing per minute at the foot of the downcast; provided the volume of air is properly circulated and sufficient for the removal of deleterious, noxious, and dangerous gases, what number of men and mules may be legally employed in this mine? (Demonstrate in figures.)

(b) Assuming a velocity of 4 feet per second: what volume of air is there passing an airway 8 feet wide at the roof, 6 feet wide at the floor, 1 feet high on one side and 5 feet on the other? (Demonstrate by figures.)

ANS.—(a) There must be 100 cubic feet of air per minute for each person and 300 cubic feet for each animal; hence, 25,000 cubic feet will supply 250 men or 83 1/3 animals. Assuming that there are 20 mules in the mine, they will require 6,000 cubic feet, which leaves 19,000 cubic feet of air that will supply 190 men.

(b) $\frac{8+6}{2} = 7$; $\frac{4+5}{2} = 4.5$; then, $7 \times 4.5 = 31.5$ sq. ft. area.

$q = \text{area} \times \text{velocity per min.}$

$31.5 \times 4 \times 60 = 7,560$ cu. ft. per min.

QUES. 9.—(a) If a fan running 50 revolutions per minute produces 25,000 cubic feet of air per minute, what volume will it produce if the speed is increased to 75 revolutions per minute? (Demonstrate by figures.)

(b) When would you consider a mine properly ventilated?

ANS.—(a) With an increased number of revolutions the velocity of the air is increased and also the friction, which complicates matters to such an extent that the general assumption that the quantity of air in circulation is proportional to the number of revolutions of the fan is incorrect,

$50 : 75 = 2,500 : 37,500$ cu. ft.

In practice the quantity of air is more nearly in proportion to the fifth root of the fourth power of the number of revolutions per minute or in this case

$q = 25,000 \sqrt[5]{\left(\frac{75}{50}\right)^4} = 25,000 \sqrt[5]{1.5^4} = 34,575$. Ans.

(b) When there is sufficient air circulating in each split to comply with the law and as much more as is necessary to make the mine safe in every place. Too much air is bad in winter as it raises dust and dries out the coal causing it to air slack. The air should be sent to every working face, or the mine will not be properly ventilated.

QUES. 10.—Why is each individual's cooperation necessary in the operation of a mine?

ANS.—Carelessness on the part of any one individual in a mine, endangers the lives of all. By leaving a door open, by shutting a

door, by means of blasting; by going into abandoned workings or past a danger signal, an explosion might occur. Each man should comply with the rules of the colliery and the state and take greater precaution to preserve the lives of his fellow working men than his own. He will then not take risks.

QUES. 11.—(a) Name the chief factors that are essential to successful mine haulage.

(b) What arrangements would you make for the safety of drivers and other persons along haulage roads?

ANS.—(a) Good solid road beds well drained, well lined, track tamped to grade and properly gauged.

(b) The haulage roads should be everywhere 18 inches wider on each side than the top width of the car. Posts on the haulways should not extend beyond the rib if thereby they lessen this distance. Safety holes should be cut in the ribs at stated intervals and white-washed so that pedestrians can find escape from a passing trip. The floor on each side of the track should be kept clean of rubbish that might trip a person in hurrying out of the way of the trip.

QUES. 12.—(a) If a prop 5 inches in diameter is required in a 5-foot coal seam, what should be the diameter of the prop for a 6-foot and 8-foot seam? (Demonstrate by figures.)

(b) State how you would timber a working place that is dipping having a soft bottom.

(c) State how you would timber a working place that is dipping having a soft roof.

(d) State how you would timber a working place that is dipping having a soft roof and bottom.

(e) State how you would timber a working place having a soft bottom and roof going to the rise.

ANS.—(a) The diameter of a prop should be proportional to the thickness of the seam in order to present the same resistance to crushing or bending; hence, $5 : 6 = 5 : x = 6$ inches for 6-foot seam, and $5 : 8 = 5 : x = 8$ inches for an 8-foot seam.

(b) If in a room, the prop should be placed on a plank to give it more bearing, and the prop slanted up the dip to allow for any movement of the floor. In slopes the timbers should be placed skin to skin and rest on sills that reach from side to side.

(c) If the roof is not too soft, plank collars should be used on the props in a room and, if necessary use two props to each collar. In the case of a slope, it should be lagged between timber sets, or if very soft, timbers should be put skin to skin.

(d) If a room, use caps and sills of planks, placing the props slightly inclined to the rise. If a slope, place timber sets skin to skin and at right angles to the roof and floor, using side braces or spacing sticks.

(e) In this case the timbers should be set just as soon as the cut is made and the coal out of the way. Care is to be taken to see that there is no loose coal to come down and with it the roof. Planks should be used for sill and cap pieces for each prop, the latter being placed slightly toward the rise.

QUES. 13.—(a) How would you construct a good solid roadway in rise workings having a very soft bottom?

(b) How would you construct a good, solid roadway, in dip workings having a very soft bottom and wet?

ANS.—(a) By first putting down longitudinal sills for the cross-ties, and filling in between the ties with the material best suited to make a good road bed. Ashes and dirt about equally mixed might answer for filling.

(b) Cover the floor with strong lagging; have good ditches if necessary each side; put sills on the lagging and use ashes or broken stone entirely for filling.

QUES. 14.—(a) Given a mine worked on the double-entry system, suppose it is necessary to split the air-current at the first and second north cross-entries, which of the two entries would you use as the intake airway?

(b) Explain why either should have a preference.

(c) Describe in detail how you would arrange the intake and return.

(d) How would you control the air-current so as to deliver the necessary quantity of air to the different splits?

ANS.—(a) Use the second north cross-entry as intake, supposing No. 1 and No. 2 make a pair.

(b) Naturally No. 1 entry will be the haulway, and the return should be on the haulway away from the rooms.

(c) Crossover on No. 2 entry, stoppings between Nos. 1 and 2. Curtains to send air up through those rooms where it is needed. Doors only on slant breakthroughs next to the parting where collecting is being done. Air to be carried to the last breakthrough on No. 2 entry before sent to the return.

(d) By means of regulators and anemometer readings in the intake entry. Theoretical calculations are not to be depended on in such cases.

QUES. 15.—Given two airways of equal length and size, one of which is driven to the rise and one to the dip, the pressure of each being the same, which of the two airways will receive the greater quantity of air? Explain your reasons for your opinion.

ANS.—The dip airway, as the heavier cool air will have gravity to assist its movement, while in the rise heading part of the pressure is expended in overcoming gravity. As a rule it is easier to lower down hill than to pull up hill.

QUES. 16.—Name certain conditions under which dry, rich, fine coal dust may become a dangerous agent in coal mines.

ANS.—Impalpable, dry coal dust, when floating in a mine atmosphere, is always a menace to safety. A powder explosion, blown-out shot, a small gas explosion, a live wire, or any flame may ignite the dust and cause an explosion.

QUES. 17.—(a) Name the different methods of mine haulage in use in coal mines.

(b) Name certain conditions under which one system of haulage should have the preference over another.

(c) Name the conditions under which mules should be replaced with mechanical haulage.

ANS.—(a) Locomotive; gasoline, compressed air, electric. Rope; endless rope; tail-rope; gravity planes; engine planes; head rope combined with motor haulage. Animal haulage.

(b) Gasoline locomotives are used to advantage where the grade is not too heavy, where there is no electric haulage, also for gathering trips. Compressed air haulage is used in gassy mines, where there is danger in the use of electric locomotives. The electric locomotive is used in non-gaseous mines. Where the mine is large and the trips heavy it possesses advantages over other systems of motor haulage. Engine planes and gravity planes are useful where coal is to be raised or lowered inside the mine, and where motor haulage is impossible. Endless-rope haulage may be used to advantage on entries having two tracks, if however there are side tracks to be used here and there for trips to pass it has no advantage over the tail-rope system. If entries are curved or sinuous and several cross-entries are to be served so as to make regular trips, tail-rope haulage is preferable to endless rope. In the endless-rope system the engine runs continuously in one direction; in the tail-rope system the engine is reversed when bringing out or taking in a trip. Rope haulage is preferred to locomotive haulage where grades are uneven, or heavy.

(c) Mules should be replaced by mechanical haulage as soon as the mine development will warrant. It will be found impracticable in many cases to discard mule haulage entirely, particularly, in gathering cars from rooms and headings.

QUES. 18.—(a) At what season of the year is the roof of coal mines most affected?

(b) Why is this true?

(c) What method would you suggest to overcome this difficulty?

ANS.—(a) Summer, if the moisture in the atmosphere is the cause.

(b) The outside air carries considerable moisture which is sometimes precipitated by the change in temperature, and this may be absorbed by some kinds of roof rock to such an extent that it will fall.

(c) Roof that readily air slacks comes down in small pieces as a rule; if the roof rock is liable come down in large pieces it should be taken down before it has a chance to fall and injure some one.

ORE MINING AND METALLURGY

Metallurgy of Mercur Gold Ores

Methods Used at the First Mill in America to Successfully Use the Cyanide Process

By Theo. P. Holt*

It seems rather remarkable that the first gold mine to successfully apply the cyanide process on the American continent should possess one of the most difficult ores treated at the present time. Looking into the history of the Mercur camp one finds that

slime separately. It was then that George Moore conceived the idea of the vacuum filtration of slime, and D. J. Kelly originated his pressure filter. The struggle with slime was a long and strenuous one, for Mercur slime is among the worst to treat.

The only plant operating on Mercur ores at present is the Golden Gate Mill, shown in Fig. 1, owned by the Consolidated Mercur Gold Mines Co. All the other plants of the district have exhausted the visible supply of workable ore. The Golden Gate mill treats some tailing, but for the most part draws its ore supply from the Mercur, Golden Gate, and Brickyard mines. The ore is separated into oxidized, locally termed "mixed," and "base"



FIG. 1. GOLDEN GATE MILL, MERCUR

this very fact of the ore being refractory was responsible for the early adoption of the cyanide process. All hydrometallurgical processes in use at that time were tried and found wanting. The pan-amalgamation process, which had proven satisfactory in treating many ores, could recover only a very small per cent. of the Mercur gold. With the remodeling of the pan-amalgamation mill into a cyanide mill in 1892, the management entered a new and untried field of metallurgy. The cyanide process owes much to the broadmindedness of those in charge of the Mercur plants, whose policy has always been one of original investigation and development rather than the imitation of neighboring plants.

To begin with, the Mercur ores were oxidized and of a high milling grade. It was found possible to secure from them a satisfactory extraction by coarse crushing and leaching in shallow tanks. When later the base ores were encountered, this simple method of treatment was no longer possible. Large roasters to oxidize the ore were found to be the best solution of the new problem. Slime, always a serious problem, became more so when finer crushing became necessary, so that means had to be devised for treating the

grades. Two separate crushing units are provided for the two grades of ore and they are not mixed until the base ore has passed through the roasters. The "mixed" is not roasted but passes directly to the classifiers for the separation of sand and slime.

The general scheme of treatment may be readily followed by reference to the flow sheet shown in Fig. 2. The mixed ore is crushed to pass a $\frac{3}{4}$ -inch screen, while the base ore is crushed to pass a $\frac{1}{8}$ -inch screen. The base ore is delivered to supply bins and from these is passed to the Jackling roasters by automatic feeders. The roasters, all of the straight-line type with drag-chain rabblers, have a capacity of about 80 tons each per day. Recently this tonnage has been considerably increased by "speeding up" the rabblers. From the cooling hearth of the furnace the roasted ore is elevated to the classifiers and along with the fine "mixed" ore passes to the "mixer separators." These are of the log-washer type peculiarly adapted to the separation of the coarse part of the sand. However, it will be noted from the flow sheet, that the classifiers are relied on for the removal of the fine sand. These have a special drive, devised by Albert Johnson and T. H. Franklin, which has proved to be much superior to the old type.

*Asst. Prof. of Mining and Milling, University of Utah, Salt Lake City.

The slime from the classifiers goes direct to the thickeners and without further treatment to the vacuum filters. The sands are discharged into a launder with the mill solution and are carried by gravity to the leaching tanks, where they are treated 1 days with a cyanide solution containing 1.5 pounds of sodium cyanide per ton.

The Mercur ores occur as a series of altered sedimentaries of varying composition. The ore treated is drawn from several mineralized zones or strata, thus giving a wide variation in the kinds of gangue; however, there are several peculiarities common to Mercur ores. In the first place the gold is always extremely fine, it being impossible to detect any free particles with a glass; also the gangue is easily permeated by the cyanide solutions, which makes fine crushing unnecessary. Most of the ore when crushed to $\frac{1}{2}$ inch will yield as much gold as when crushed to pass a 100-mesh screen. In fact, in the case of a long contact, the coarse ore will give a better extraction than when the ore is slimed. A certain per cent. of the gold present is almost instantly dissolved in a cyanide solution, while of the remainder, a very large per cent. is absolutely insoluble. During the past year the ore treated in the mill averaged \$3.21 per ton. During the same period the mill tailing averaged 88 cents, which gives a low recovery for a gold ore. This tailing can be very slightly reduced in gold by further treatment, and the remainder has been termed "insoluble gold."

During the past 2 years experimental work has been carried on both at Mercur and the Utah School of Mines to determine if possible the conditions surrounding this so-called "insoluble gold." A detailed survey of this work is beyond the scope of this article,

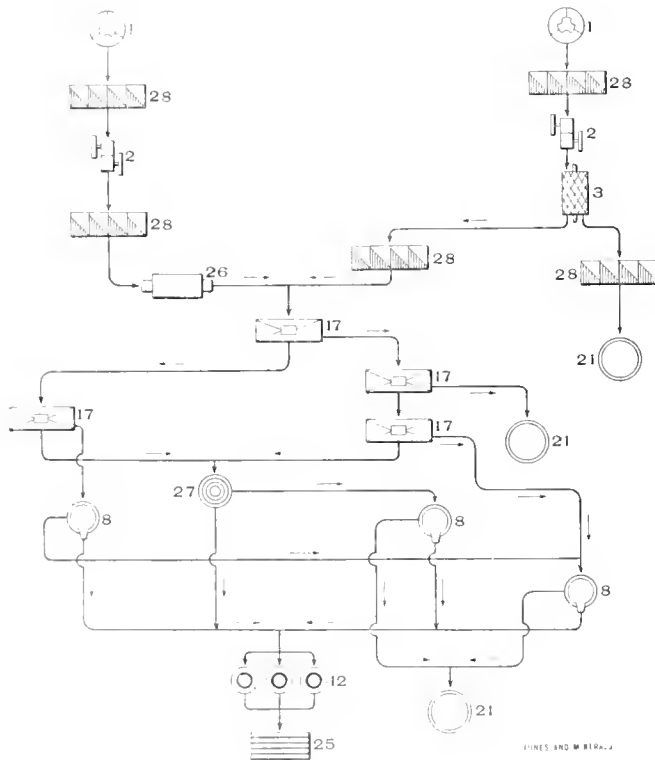

FIG. 2. FLOW SHEET, GOLDEN GATE MILL.

1, Crusher; 2, Rolls; 3, Trommel; 8, Classifiers; 12, Pulp Thickeners; 17, Spitz-kasting; 21, Cyanide Tanks; 26, Rollers; 27, Callow Tanks; 28, Ore Bins.

and only such parts are included as it is believed will be of more than local interest.

Screen sizing tests were made on the ore at all stages in the process of treatment to determine the rate at which the gold passed in to solution. The four following tests on an oxidized sample may be taken as typical. The first was made before the ore entered the cyanide solution; the second and third about 10 minutes later, and the fourth test is that of the sand tailing after 96 hours leach:

1. FINE OXIDIZED ORE

On Mesh	Per Cent. Weight	Assay	Per Cent. Total Value
4	34.55	\$2.37	27.2
10	20.80	3.31	23.0
20	6.10	2.58	5.4
40	3.60	4.13	5.0
60	2.10	3.32	2.3
100	1.30	3.51	1.5
Slime	31.30	3.41	37.0

2. SAND DISCHARGE FROM NO. 1 MIXER

On Mesh	Per Cent. Weight	Assay	Per Cent. Total Value
4	37.8	\$1.03	35.1
8	33.5	1.24	37.2
16	10.7	1.03	10.1
16	7.8	1.03	7.2
Slime	10.1	1.13	10.3

3. SLIME OVERFLOW FROM NO. 2 MIXER

On Mesh	Per Cent. Weight	Assay	Per Cent. Total Value
100	2.5	\$.83	1.9
200	1.2	.83	1.0
200	3.8	.83	2.8
Slime	92.4	1.13	94.3

4. SAND TAILING

On Mesh	Per Cent. Weight	Assay	Per Cent. Total Value
4	21.9	\$.83	18.4
8	37.2	.93	34.9
16	18.3	.83	15.3
40	8.4	.93	7.9
40	7.3	1.03	7.5
Slime	7.0	2.27	16.0

Two points are readily observed. (1) Fully 80 per cent. of the soluble gold is extracted in the first few minutes of treatment. (2) The gold in the slime is increased rather than lowered by long contact with the gold-bearing cyanide solutions. The sand tailing on the average is somewhat lower than indicated in the sizing test and the slime tailing is slightly higher.

The question is sometimes asked: "Why is it necessary to roast the Mercur base ores?" The first reason suggested was the association of the gold with tellurium. But the presence of tellurium has not been proven, although the ore has been analyzed repeatedly. Indirect methods, such as the use of bromocyanide, have also failed to indicate any association of the gold with tellurium.

Ferrous compounds exist in the ore chiefly in the form of the mineral melanterite, the hydrated sulphate of iron. The oxidation of this objectionable compound is one purpose of the roast; in fact, the operation of the roasters is regulated according to the amount of this mineral present, as shown by the following test used as a check on the work. A shift sample from the roaster is ground to pass a 60-mesh screen. Ten grams of the sample is placed in a wide-mouth bottle containing 100 cubic centimeters of water. A .01 per cent. solution of potassium permanganate is added from a 10-cubic centimeter pipette. Should the color fade completely when the bottle is shaken, a second pipette of the permanganate is added. The sample is recorded as from 65 to 95 per cent. oxidized, according to the shade of the color and the number of cubic centimeters added. With the Mercur ores it is also possible to detect a "too hot" roast by the peculiar purple tinge assumed by the solution.

It is well known that ferrous sulphate will precipitate gold from cyanide solutions aside from causing a high consumption of cyanide, and it was thought that this compound might in some way be responsible for the insoluble gold. Several weeks of experimenting lead to the following conclusions:

1. Gold is precipitated from cyanide solutions by ferrous sulphate, but it is readily redissolved by free cyanide upon the oxidation of ferrous compounds.

2. Ferrous sulphate is readily oxidized in the presence of an alkali by agitating the pulp with air. The acid and neutral solutions of this salt are quite stable.

3. The complete oxidation of ferrous sulphate in the Mercur ores does not lower the amount of insoluble gold although it decreases the consumption of cyanide.

The Mercur base ore was thoroughly neutralized by agitation with a solution of lime and then treated with cyanide. This treatment gives as low a cyanide consumption as does the roasted ore, but the amount of gold extracted is less; also there is a greater tendency to precipitate the gold in case of long contact with the ore.

When the base ore is boiled for some time a black scum rises to the surface of the water. A large number of such tests showed that the more refractory the ore the greater the yield of black scum. Upon analysis this proved to contain a large proportion of free carbon, and carries high values in gold. Some samples taken from ore carrying \$4 per ton assayed over \$100. It is, of course, impossible to remove all the carbon in this way, but samples thus treated preliminary to cyaniding gave a much lower tailing. This, coupled with the fact that the gold in the scum is insoluble in cyanide solution, lead to the conclusion that uncombined carbon is responsible for the so-called insoluble gold in Mercur ores.

A later set of tests on different classes of Mercur ores show a very remarkable relation between the content of free carbon and the insoluble gold in the ores.

Sample	Carbon Per Cent.	Ounce Insoluble Gold
Oxidized105	.029
Raw base358	.075
Pyritic base450	.110

With the last two samples reprecipitation was more rapid than solution after an hour of agitation. In fact, the last sample showed not so much as a trace of gold in solution after 20 hours' agitation.

A considerable amount of the carbon is oxidized in the roaster. If the temperature is raised sufficiently in the presence of plenty of oxygen, practically all the carbon may be removed. But here again another difficulty is met: The ore is practically self-fluxing and the gold is easily encased in the gangue if a sintering temperature is reached. The effect of temperature on the roast is shown by a graph of a series of tests. These roasts were run under favorable conditions, having an abundant supply of oxygen present. It would hardly be possible to duplicate these conditions on a commercial scale.

The detailed cost of treatment included below is taken from the last report of the Consolidated Mercur Gold Mines Co. During the past year the plant treated 239,190 tons of ore with a recovery of \$2.32 per ton. This included 78,897 tons of base ore which was put through the roasters. The roasters at the present time are handling 86 tons each. The cost of roasting per ton for the year is as follows:

Labor	\$ 2561
Power0550
Coal3283
All other items0870
Total	\$.9201

Of the total tonnage, 182,708 were treated in the leaching department at the following cost:

Labor	\$ 1779
Power0111
Water0239
Cyanide2151
Lime0200
All other items0288
Total	\$.4867

A very thorough wash is obtained in the leaching vats, as is shown by the fact that the sand tailing averages less than 6 cents

per ton in dissolved values. The slime plant is less satisfactory in this regard, as the ore is discharged with 11 cents dissolved gold. The cost of classifying, settling, and filtering is 11½ cents per ton of slime. The cost of precipitating is divided as follows:

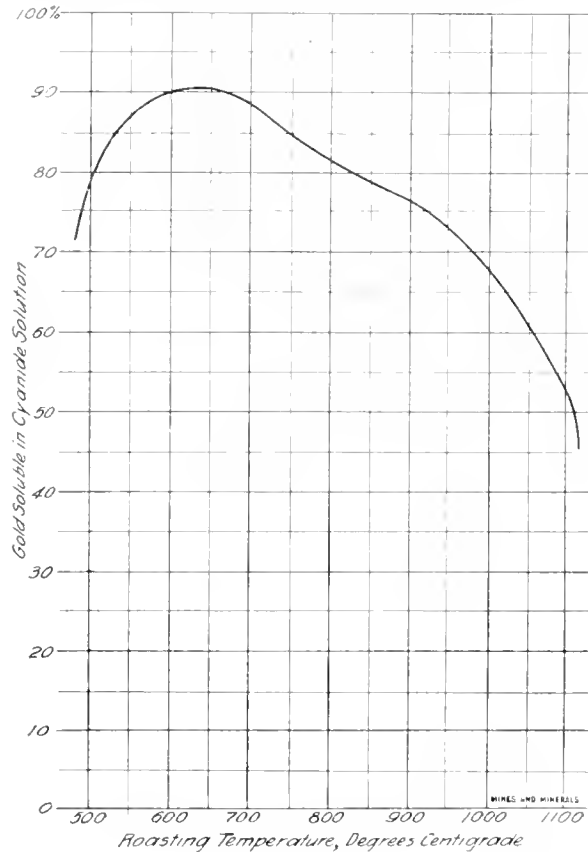

FIG. 1. ROASTING RESULTS

	Per Ton of Ore
Labor	\$.0152
Power0038
Zinc dust0296
All other items0046
Total	\$.0532

The refinery costs were 4.10 cents per ton of ore treated.

采 采

Garnet Veins on Labrador Coast

A garnet deposit of exceptional possibilities has been discovered on an island situated in St. Michaels Bay, southern Labrador (part of Newfoundland's domains), about 35 miles north of Belle Isle, in the straits, according to information from United States Consul at St. Johns. The island is about a mile long, half a mile wide, and 200 feet in height. The vein occurs on the south side of the island near the edge of the cliff, and is exposed for about 330 feet in length and 11 feet in width. It is composed of crystals of garnet about the size of large oranges, with sufficient matrix (a flinty quartz and mica) to hold them together.

On the north side, about 60 feet from the solid vein, and running parallel with it, are smaller crystals, but much farther apart. Beyond the 330 feet in length the rock is covered with sod, and it is assumed this sod covers the extension of the vein. Over the south-side edge of the cliff, which is almost perpendicular, the large garnets are profusely exposed down to about sea level.

The garnet has been tested for abrasive work and pronounced superior for that purpose to any found elsewhere. It is also thought that slabs of any size and thickness can be cut and polished. If so, it will be interesting to building trades, as they would be exceedingly handsome, durable, attractive, and new for both inside and outside ornamental work. Shipping facilities are excellent, the water being deep, and there is perfect security for the largest ships.

Geologic Structure of Silver Districts

The Common Features of the World's Greatest Silver Districts. Volcanic and Sedimentary Formations

By W. G. Motteson

In this article the writer deals with a description of silver deposits whose formations are essentially volcanic, and those whose formations are essentially sedimentary.

Faulting has been a conspicuous factor in the history of the vein formations of the various famous silver camps, consequently it is not surprising to learn that approximately 90 per cent. of the ore bodies of these districts are of the fissure-vein type with some few modifications.

Formations Essentially Volcanic.—The Comstock lode*, at Virginia City, Nev., is a true fissure vein filled with metalliferous gangue enriched in numerous places termed "bonanzas." The main fissure was probably the result of rupture and dislocations following some volcanic outburst. The faulting, which preceded ore deposition, also produced secondary fissures, chief of which is the famous "east vein"; later an uplifting of the foot-wall, involving enormous friction, occurred, resulting in the separation of the foot-wall and hanging wall into sheets parallel to the fissure for a long distance from it. A secondary effect of the same force was the formation of innumerable cracks in these sheets, nearly perpendicular to their partings. The fracturing of the hanging wall in such a manner had an important bearing upon ore deposition, as mineral waters were deflected to a great extent into this fractured mass, dissolving silica and metallic salts from the rocks and depositing them in the main fissure.

This fissure is not simple, but ramified, and but a small fraction of it has been filled with ore. The main body of the lode is a belt of quartz and vein matter 10,000 feet long and several hundred feet broad, showing diverging branches at both ends. The hanging wall is diabase, while the foot-wall for three-fourths the length of the main fissure, consists of a granular diorite, the remainder being composed largely of metamorphic slates. Practically all of the valuable ore bodies of the Comstock have been found at or close to this earlier diabase, and at this point only has exploration been successful, the ores of the most important mines lying on the contact between the diabase and diorite.

The vein consists of clay quartz, argentiferous minerals, and country rocks varying in size from pebbles to horses thousands of feet in length. The famous bonanzas have all been found in a secondary fissure in masses of quartz of lower grade, and closely associated with the diabase. This secondary fissure was the result of faulting preceding ore deposition. Faulting also occurred during the formation of the ore and continued afterwards, as is evidenced by the crushed condition of the ore caused by a movement in the direction of the dip of the main fissure.

The Comstock lode is similar to the Tonopah, Nev., and to the Pachuca, Mex., silver deposits, in the vein-filling material and in the propylitic alteration of the wall rocks at a distance from the main vein. "Horses" are also found in the Pachuca veins, but not to such an extent as in the Comstock. Brecciation in and along the veins is common to the formations of Pachuca, the Comstock, and Guanajuato, Mex. The famous Nevada lode also shows a marked similarity with the districts of Cobalt, Can., and Guanajuato, in the close association of the ores with diabase rocks.

At Tonopah, not far distant from the Comstock, the vein matter filled fissures which were formed by the heavings of volcanic forces. Although the veins possess the appearance of true fissure formations, there is geological evidence that they formed along zones of fracturing or sheeting in the andesite and have replaced the andesite to some extent. Complicated faulting is manifested throughout the area, all the rich veins occurring in a fault block bounded by four faults. The wall rock is of andesite, highly silicified near the veins, but showing considerable propylitic alteration farther away. In structural character, the veins form what might be termed a splitting and reuniting group. Rich bonanzas have been found at the intersection of the traverse fractures with the main vein zone.

The main ore-bearing zone of the Pachuca district of Mexico is a fissure carrying a white quartz gangue and having many branches both on the foot- and hanging-wall sides. In this respect, it is somewhat similar to the Comstock lode. The ore is found in andesite, the indefinite wall rock showing extensive silicification near the veins with considerable propylitic action as the distance from the veins increase.

There is considerable compound branching of the veins in the Pachuca area, forming a splitting and reuniting group. "Horses" are a common feature of this compound branching. As at the Comstock, "horses," or fragments of rocks, displaced from the walls and floating in the main vein, are found at all known depths and of all dimensions. They are more or less angular and are surrounded by a concretion of quartz and sulphide.

The principal veins are remarkable for their constancy and length. A compact breccia is found in the lower and deeper parts of the veins, resulting from dynamic actions subsequent to the filling of the fissures. This occurrence has proved of great influence in the distribution of the rich ore.

Numerous bonanzas have been found at Pachuca, invariably at the junction of a cross branch with the main vein. They are

quite irregular in form, frequently somewhat elliptical, and show a decided inclination for the oxidized zone.

Pachuca, from the standpoint of vein formation, is similar to Tonopah, in that the vein system forms a splitting and reuniting group; to Comstock and Guanajuato in the mineralization and brecciation of the veins; to Tonopah, Comstock, Guanajuato, Aspen, Colo., Park City, Utah, and the Consols mine, Broken Hill, Australia, in the occurrence of bonanzas at the intersection of cross-veins with the main fissures or ore-bearing zones; and to Tonopah in the silicification of the walls close to the vein material with marked propylitic alteration farther away.

The district of Guanajuato, Mex., contains ore deposits similar in many respects to those of the Comstock lode and Pachuca. In the Guanajuato district there has been considerable volcanic activity. Igneous intrusions are abundant and have played an important role in the mineralization of the district. Faulting is extensive and complicated, the ore-bearing solutions invariably following the lines of fracture thus produced. The vein filling may be described as quartz with disseminated particles of silver sulphide. The ore bodies have been formed by replacements of the country rock: the ore solutions permeating far into the rock where the mineral has been concentrated in the crushed zones and intersections of the faults.

An extensive intrusion of a dioritic magma resulting in anticlinal uplifts and extensive metamorphism, later followed by settlement of the magma, is the cause of the faulting. The formation of these fault fissures was accompanied by brecciation and grinding along the walls. Thus an outlet was provided for solutions



ASPEN AND ASPEN MT. FROM SMUGGLER HILL

* Becker—Monograph III.

to deposit their mineral-bearing contents by replacement. Later there was a further faulting, with brecciation of the previously deposited vein material and a continuation of deposition. The deposits are encased in argillaceous schists, and in diabasic and rhyolitic rocks. The highest grade ore is found in chutes at the intersection of complementary cross-veins.

Thus Guanajuato closely resembles the deposits of the Comstock in that the vein material consists of a quartz gangue with disseminated particles of silver sulphide; in the brecciation of the vein material; in the association of some of the ore bodies with diabase; and in the occurrence of the rich ores in bonanzas at the intersection of the cross-veins.

Ores of the Cobalt district, Canada, according to Willet G. Miller, of the Canadian Geological Survey, are derived from a diabase magma. The deposits occupy narrow, practically vertical fissures or joints which cut through a series of slightly inclined metamorphosed, fragmental rocks of lower Huronian age. The fissures were produced by gradual shrinkage of the cooling diabase after eruption; ore-bearing solutions followed the openings and deposited their contents.

Cobalt silver deposits resemble the Comstock and the Guanajuato deposits in their important relationship to diabase magma.

Formations Essentially Sedimentary.—The ore body of Aspen, Colo., is one of the largest continuous silver deposits ever found in the United States. It may be generally classed as a fissure formation, the vein matter consisting of a more or less alteration of the partly decomposed, underlying and brecciated dolomite with associations of baryta and calcspar, rarely marble and quartz. The ore is generally found distributed throughout this material but at depths it has been found in the solid limestone, where a "substitution" or "replacement" has taken place between the carbonates and the ore solutions. Water-formed cavities in blue limestone lined with rich ore are also found close to the main ore body. Thus, in some respects, the deposit resembles both a fissure vein and a mineralized replacement zone.

The Aspen ore-bearing district is cut by a series of faults comprised in north-south and east-west systems and resulted from the uplifting of the sedimentary beds, which in turn resulted from the upward propulsion of igneous rock from a large reservoir below. Aspen Mountain, the locus of the mining district, has been formed through a great fault movement. The most important faults originated before ore deposition and are termed by Spurr as "pre-mineral." The fault fissures have been the chief channels of the ore solutions, and consequently are important in determining the final location of the ore.

Some of the faults are nearly vertical. Many times faulting is almost coincident with the bedding. Such planes show great persistence and a large amount of displacement. Subsequently they have played an important part in the economic development of the entire district, but two such faults in particular have had a much greater influence than the others. One of these, termed the "Contact," is strictly parallel with the bedding at the contact between the blue limestone and the underlying dolomite of the Leadville formation. The richest ore of the district, moreover, has been found at the intersection of the smaller faults with the "Contact," or larger fault fissures.

Thus, with scarcely a single exception, the ores at Aspen are found in the faults or along faulted and fractured zones. The surface extent of the district which has been actually productive is practically identical with the pre-mineral faulted and uplifted region, the appearance of comparatively unbroken strata reveal-

ing an immediate falling off in the tenor of the ore and then disappearance. The Aspen deposits find a close resemblance in the Comstock lode and Pachuca districts in the type of vein formation, in the faulting, and in the occurrence of the richer chutes of ore at the intersection of the secondary fissures with the main faults. The vertical fault fissures of Aspen are also analogous to those found in the Cobalt district of Canada. Faulting has also divided the area into fault blocks, as at Leadville and Tonopah.

At Park City, Utah, the principal ore bodies occur either in fissures or in pockets in limestone beds. The rich silver deposits are found in the fissure veins, but the bulk of the ore has been deposited from solutions in limestone caves. Numerous fissures occur throughout the district, the ore being found in small paystreaks frozen to the walls and in groups of paystreaks included in lodes. The lodes and pockets of ore occur in frequent and intimate association with the porphyry, while the ore-bearing fissures cut indiscriminately across this and all other formations. The porphyry dikes are extremely important, as by cutting through and fracturing the strata they opened the rocks for the mineral-bearing solutions.

Much faulting is evidenced in connection with the principal mineralized fissure zone at Park City, due to the folding that formed the Wasatch Mountain Range. Faulting, fissuring, crushing, and fracturing, together with the igneous activities prepared the way for the mineral-bearing solutions. In general, the ore is found in



A SILVER VEIN

beds of limestone or quartzite through which the fissures pass. The influence of the wall rock is shown by the breccia detached from the walls of the fissures, which provided evidently a loose, coarse, or porous material through which the mineral-bearing solutions could easily pass and deposit the ores. Those ores, which are concentrated within the fissures are generally of high grade. Ontario quartzite is one of the main ore-bearing formations and forms the wall rock of the vein to a considerable depth.

Several vertical fractures in this district have had a strong influence upon ore deposition. The ore bodies or shoots are found to occur in the veins where the latter are cut by these verticals, which thus acted as feeders through which the mineral-bearing solutions passed until precipitated in places possessing the favorable conditions. Deposits of ore have also resulted from the intersection of several large verticals or, in other cases, of ore-bearing fissures.

Thus, at Park City, the valuable silver formations were in deposited fissures crossing the strata transversely, and are intimately associated with masses of crushed rocks. The undisturbed rocks are everywhere barren of ore.

Park City ore deposits closely resemble those at Comstock, Pachuca, and Guanajuato in regard to the presence of brecciated masses in the vein material. The extended block faulting of this region is also characteristic of Leadville and Tonopah, and, as at Aspen, the seat of greatest disturbance is the seat of ore deposition. The bedded deposits find a like similarity in those of Leadville and Aspen, Colo., occurring as replacements in Carboniferous limestone, and in frequent and intimate association with porphyry intrusions. The faults of Park City, Aspen, Guanajuato, and the Comstock are all pre-mineral, and in each instance continued faulting has followed ore deposition.

The lead-silver deposits of the Cour d'Alene district, Idaho, were formed by replacement of siliceous sedimentary rocks along zones of fissuring and combined fissuring and shearing. The age of the veins is probably Mesozoic, but the surrounding formation is pre-Cambrian, including slates and quartzites near the contact with a granite mass of intrusive origin. Many of the productive

fissures and fractures, exhibiting a varying degree of complexity.

The fissure veins of the Coeur d'Alene district have been folded and compressed so as to develop slaty cleavage in all but the massive quartzites. Local zones of slaty cleavage have, in some instances, been the accompaniment of the lead-silver lode.

The theory is advanced that the ore-bearing fissures were formed substantially at the same time as the main faults and are the effect of stresses set up within the faulted blocks in consequence of their displacement. Thus the major faults, although not ore-bearing themselves, played an important part in the initiation of conditions favorable to ore deposition.

The Coeur d'Alene fissure veins find their closest resemblance, structurally, in the fractures of the Tonopah vein system. The faulted area is somewhat analogous to that of Leadville, Aspen, and Tonopah in that it is divided by faults into fault blocks.

The main ore-bearing stratum at Leadville is the Carboniferous blue limestone, which contains a prominent intrusive sheet of gray porphyry 50 feet or more in thickness. Where such sheets have cut across the stratification, they have exercised a most important influence on the precipitation of ores from solution. Thus it is extremely desirable to locate all gray porphyry bodies, for experience has disclosed that valuable ore is generally associated with them.

The ore deposits of Leadville are typical replacements in limestone somewhat similar to the bedded limestone deposits of Park City. Complicated faulting has taken place throughout the district, the faults running generally in a north and south direction. Six faults, approximately parallel, have divided the region into six fault blocks. This abundant faulting has been very favorable to secondary enrichment.

An important structural feature, which bears a close relation to ore development, is the tendency for the beds to bend sharply downward along an east and west line. Emmons stated that some of these beds had been steepened from 15 to 45, 60, and even 80 degrees, while at other points this tendency had passed into an actual fault of small displacement and distributed on several planes of movement. Along this east-west line, there has been an unusual ore concentration, and, in a vertical direction mineralization has also extended to a considerable depth. The ore here seems to occur largely in chutes.

The ore bodies of Leadville find their closest analogy in the bedded deposits of the Park City district. In both instances, the ore bodies show a decided preference for the Carboniferous limestone, occurring therein as replacement bodies. The fissure veins of Aspen are also found largely in the Carboniferous blue limestone.

The ore deposits embraced within the territory of Broken Hill, Australia, vary somewhat, but a general idea of the vein formation may be obtained from a description of the ore occurrences in two important mines, the Broken Hill Consols and the Broken Hill Proprietary. In the Consols mine the lode is a silver one, presenting the features of a true fissure vein. It is very well defined and persistent, cutting obliquely across a bedding of gneiss and schist, and continuing uninterrupted through various bands of eruptive amphibolite.

The ore deposits are the result of the intersection of numerous cross-cutting veins with the main lode. By far the greater part of the ore has been confined to those portions of the lode enclosed in amphibolite, the boundaries of this rock proving identical with the limits of the ore-bearing chutes. Where metamorphic rocks are intersected, the lode invariably pinches.

The true genesis of the Broken Hill lode, of which the Broken Hill Proprietary mine constitutes a large part, has been a matter of controversy for years and data are still lacking to establish unquestionably the fissure-vein or saddle-formation theories. The walls of the lode, however, are not well defined, and metasomatic replacement is a prominent feature, the adjoining country rock bearing ore-bearing for a considerable distance from the main vein.

Conclusions.—From the structural standpoint of vein formations, the ore deposits of the various silver districts may be classified as shown in Table 1.

Other important points of similarity in common are: (1) The division of the ore-bearing area by faults into fault blocks; (2) the intimate association of ore with either diabase or porphyry; (3) the tendency for brecciation of the vein-filling material in fissure formation; (4) the presence of "horses" in large fissures; (5) the tendency of veins to form splitting and reuniting groups; (6) the silicification of the country rock near the veins with propylitic alteration farther away.

TABLE 1

District	Type of Deposit
Comstock	Fissure vein
Pachuca	Strong fault fissure
Tonopah	Replacements in andesite along zones of fracturing
Cobalt	Fissure vein
Aspen	Fissure veins with occasional replacement
Park City	Fissure veins and deposits in limestone caves
Coeur d'Alene	Metasomatic fissure veins
Leadville	Replacements in limestone
Guanajuato	Replacements in fault fissures—brecciated veins
Broken Hill	Fissure or saddle reef (?)

In general, those features common to the majority of the silver districts, and which have had considerable influence upon ore deposition are:

1. Faulting, which has preceded ore deposition in the majority of cases, generally providing channels for the outlet of mineral-bearing solutions or producing zones of fracturing and shearing for subsequent vein filling.
2. Igneous intrusion, always closely associated in some form with ore deposition.
3. The presence of cross-veins and intersecting secondary fissures, which have resulted, almost universally, in the concentration of ores in bonanzas at the intersection of such traversing fractures with the main veins.



Silver Mining in Peru

The following facts in regard to the production of silver in Peru are from an article recently published by the London *Times*: Since Peru's discovery down to as late as 1906 silver was the most important metal mined, but since that date the copper industry, through the Cerro de Pasco operations and the high price of the metal, has taken the lead. The mining of silver ores is entirely confined to copper or lead-silver bearing minerals, very little silver mineral mining being carried on. The industry is widely distributed. Of the various departments of the country, in that of Cajamarca the production is mostly all silver sulphides, the result of the lixiviating process. In Ancash the production is much the same, but a good deal of silver-bearing ore is also exported. In Lima the output is almost entirely due to the argentiferous copper mattes exported. In Junin, the Provinces of Cerro de Pasco and Yauli are the sole silver contributors; that of the former, said to be responsible for more than a third of the entire output of the country, is mainly the silver in the Cerro de Pasco copper cakes, although some argentiferous mattes and silver bars are exported; that of the latter is chiefly in the form of silver-lead ores. In Arequipa the entire production is practically due to the Caylloma mines, where silver-bearing ores and concentrates are shipped. Several other departments, of which Huancavelica and Puno are most important, contribute to the silver production. The production for 1908 amounted to nearly 200,000 kilos (220.4 short tons) of silver, of which nearly 60 per cent. was in copper cakes and mattes, 25 per cent. in silver-bearing ores, and concentrates and 12 per cent. in silver sulphides from lixiviation, the remainder being in bars. The cyanide process is receiving attention at one plant. It has been tried at another plant, but was found to be inferior to concentration.

Electrolytic Refining

Methods and Apparatus Employed at the United States Mint,
at San Francisco, California

By Edward B. Durham

The following paper was presented at the October, 1911, meeting of the American Institute of Mining Engineers, under the title "Electrolytic Refining at the United States Mint, San Francisco, Cal."

The refinery at the San Francisco Mint takes the bullion purchased by the receiving department, and carrying more than 200 parts of precious metals in 1,000, or, in mint parlance, over 200 fine, and separates and refines the various metals contained therein, using electrolytic processes exclusively.

Bullion containing silver is treated in cells charged with a nitric electrolyte. The cells produce fine silver and leave a residue rich in gold.

The residue from the silver cells, together with crude gold bullion, is treated in cells having a chloride electrolyte. These produce fine gold and leave a residue containing silver chloride. The latter is reduced to the metallic state with zinc and is then treated in the silver cells.

The various waste solutions and the wash waters, after being freed from the bulk of their precious metals, still contain copper and other metals. These are removed by scrap iron, and are then treated in the copper cells, having a sulphate electrolyte. These cells produce pure copper, and collect a residue containing lead, some gold and silver, and all the metals of the platinum group that

were in the bullion. This residue is relatively small, and is melted into bars and stored until sufficient accumulates to warrant treating it for platinum, etc.

The refinery occupies three large and three small rooms. The large ones are a melting room, 30 ft. x 34 ft.; a cell room, 39 ft. x 46 ft.; and a wash room, 30 ft. x 33 ft. The small rooms are used as foreman's office, laboratory, and generator room, respectively.

The methods here described are those in use in December, 1909, when notes for the present paper were taken.

SILVER REFINING

An outline of the system is shown by the diagram, Fig. 1, which gives the order of events and the interdependence of the various operations in a brief form.

The Apparatus.—(a) The anodes are made up of crude silver bullion, together with gold bullion that is too low in gold to be easily made up into gold anodes. The endeavor is to make a mixture, such that the anodes will run about 600 thousandths in silver, 300 thousandths in gold, and the remaining 100 thousandths in base metals. The metal is melted in No. 100 graphite crucibles, in Rockwell melting furnaces of the open-top mint type, heated with crude oil. The furnaces are used for melting both the crude metals for the anodes, and the fine gold and silver products of the refinery that are to be cast into bars. Fig. 2 is a view of the melting room. In the background are the furnaces; in the foreground, to the left, is a truck load of anodes; in the center, a truck loaded with gold bars (dark), and behind it a truck loaded with silver bars (white).

The anodes are cast in open cast-iron molds, and are of the dimensions given in Fig. 6. They are suspended from the con-

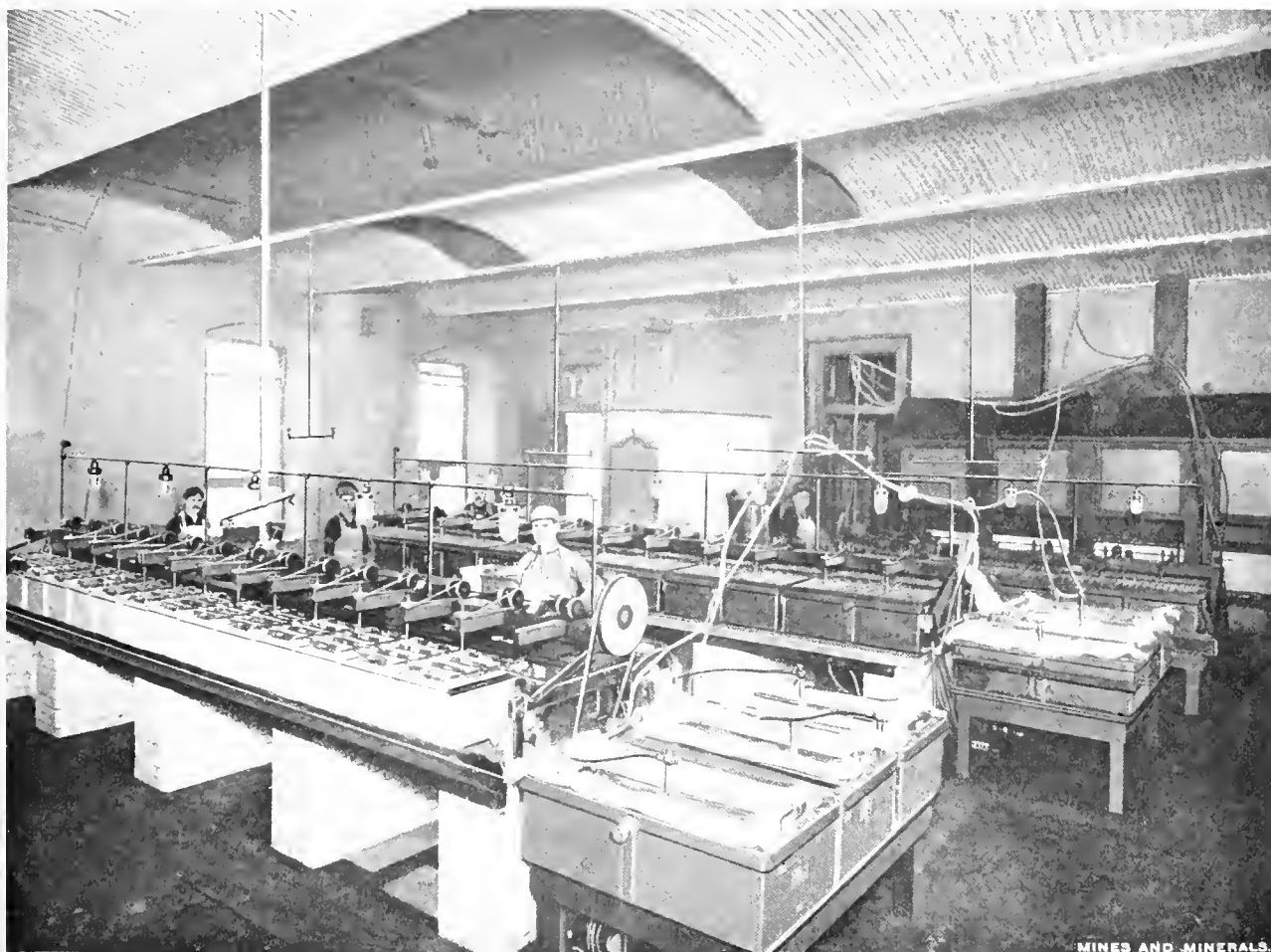

FIG. 1. REFINING ROOM, UNITED STATES MINT, SHOWING CELLS

ductor by C-shaped hooks of gold, which pass through the hole at the top of the plates and over bars which form the conductors for the current. The anodes are immersed for their full depth in the electrolyte.

The cathodes are made of sheets of silver, 1,000 fine, .051 inch thick (No. 16 B. & S. gauge) and 4 inches wide. They are immersed for 8.5 inches in the electrolyte, and are bent over at the top so as to hang from the conductors.

The crystallized silver that collects on the cathodes is loose and is removed daily. To facilitate this stripping, the cathode sheets are treated with a "dope," consisting of silver nitrate, copper nitrate, and hydrochloric acid, all mixed together, and painted on with a rag. The sheets are then dried in the dry room. One dose of this dope lasts 2 or 3 months; then the deposit begins to stick, and the plates are retreated.

(c) The electrolyte consists of water with 3 per cent. of silver, as silver nitrate, from 1.5 to 2.5 of free nitric acid, and a little glue. The latter is dissolved and poured in as a thick liquid. The effect of the glue is to toughen the deposit of silver on the cathode.

The electrolyte dissolves and retains the copper and other

screws alternately to the positive and negative bus-bars, and form the conductors. There are 19 of these across each cell, 10 supporting four cathodes each and nine supporting four anodes each. The bus-bars are of copper and extend along the main wooden frame that covers the top of the entire bench of cells. All woodwork and the copper bars are coated with "biturine solution," an asphaltic paint that comes from Australia, to protect them from the action of the acids.

The solution in the cells is kept in motion by two glass propellers in each cell. This prevents the heavier solutions from settling to the bottom, and makes the deposition uniform over the whole cathode.

Each propeller, 2 inches across, is made in one piece with a glass rod, which runs up vertically between the electrodes, and is driven by a cord running in a grooved pulley at its top. The vertical glass rods, as well as the line shaft, are carried by a wooden frame above the cells, as shown in Fig. 1.

(e) The current is a direct one of 15 volts, and passes through the 18 cells in series, as shown in Fig. 10. The amount of current is such as to give a density of 8.3 amperes per square foot of cathode surface. There are 40 cathodes per cell and each has a normal immersion of 8.5 inches. The end rows of cathodes have only one effective surface, so the total cathode surface per cell is:

$$\begin{aligned} (2 \times 8 \times 4) + (2 \times 4) &= 72 \text{ surfaces, or} \\ \frac{72 \times 4 \times 8.5}{144} &= 17 \text{ sq. ft.} \end{aligned}$$

The total current required is therefore $17 \times 8.3 = 141$ amperes. The generators are driven by current obtained from a public power line and change the direct into current of the required potential for the different operations.

(f) Centrifugal machines are used to separate the moisture from the different products of the refining process, and to wash them free from soluble matter. There are two of these machines. No. 1 belongs primarily to the silver process, and is used exclusively for silver or products charged with nitric compounds. No material containing chlorides is ever placed in it. Centrifugal No. 2 is similar to No. 1, but is reserved for the gold process and for solutions carrying chlorides.

The rotors of the centrifugals are of earthenware and provided with ducts for the escape of the liquids. When in use, the rotor is lined with one thickness of 7-ounce duck, and in this bag is placed the material to be treated. A different filter bag is kept for each different kind of material that is washed.

All the products of the silver process can be dried sufficiently in the centrifugals, so that they can be transferred to the crucibles and melted.

Fig. 3, a view of the wash room, shows the centrifugals with their driving motors.

Operation and Products.—Briefly, the anodes are dissolved; pure silver collects on the cathodes; copper and other metals forming soluble nitrates go into the bath, and gold and other insoluble metals are left as a sponge on the anodes.

As the dissolving action progresses, the anodes are taken out at intervals and the sponge of insoluble metals is shaken off into an earthenware jar, by knocking them against its sides. This spongy material is crude or black gold with about 10 per cent. of silver and 1 per cent. of base metals. After washing in centrifugal machine No. 2, it is melted into anodes for the gold process.

When the anodes are eaten down so that they barely hold together (which takes about 48 hours), they are removed, all the loose spongy material is knocked off, and the hard cores that remain

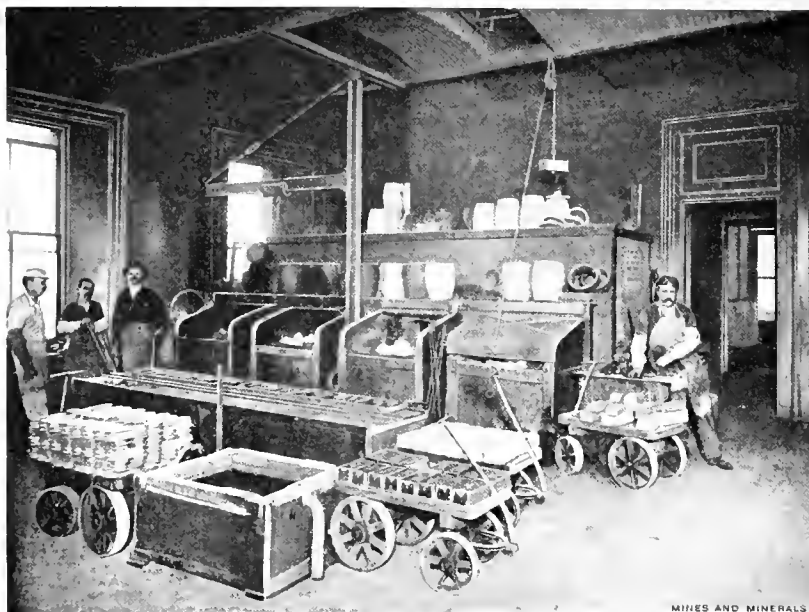

FIG. 2. MELTING ROOM

soluble base metals. These do no harm until the solution becomes so strong that the purity of the silver deposited on the cathodes is affected, when it has to be changed.

(d) The cells are of brown earthenware and their dimensions are shown in Fig. 7. Experience has shown that they are too shallow for advantageous work. There is only a small space between the bottom of the cell and the lower end of the anodes, and the slimes that collect in this space soon cause short circuits which stop the action of the cell. A new set of cells 18 inches deep inside, instead of 12 inches, is about to be installed. These deeper cells will allow longer cathodes to be used, and, since the cores that have to be retreated will be of the same size, there will be a reduction in the percentage of metal to be retreated.

The cells are placed end to end in a double row on two long benches, 12 on one bench and six on the other. This allows all the cells to be easily inspected and attended to, from one side or the other of the benches. These cells are the dark ones on the second and third benches in Fig. 1.

The anodes and cathodes are hung in alternate rows from maple strips, 2 $\frac{1}{2}$ inches apart from center to center, which extend across the cells. Along the top of each is laid a gold strip, bent into the shape of an inverted trough. These gold strips are connected by

are treated in the horizontal cells, to be described later. New anodes are then hung in their places.

So long as the electrolyte contains an ample supply of silver, this is deposited in preference to the base metals.

The electrolyte is tested at intervals to determine its strength in silver, and if this test shows that the bath is too low in silver, its strength is brought up by adding strong silver nitrate solution.

The test for silver is made by gradually adding a standardized solution of ammonium thiocyanate, $AmCNS$, to a sample of the bath, a little ferric sulphate solution having been previously added as an indicator. When all the silver has been precipitated, the ferric salt gives a red color. This is Volhard's method, and is given in detail by Sutton.*

When the bath contains about 8 per cent. of copper it has to be changed, since the silver deposited on the cathodes begins to be contaminated with the copper. This spent electrolyte is treated in the scrap-copper tank to recover the silver, and then passes on to the scrap-iron tank, where the other metals contained in it are caught, as will be described under the head of Copper Refining.

The pure silver collects in a crystalline condition on the cathodes, which are lifted out daily and cleaned over large porcelain jars. At first, the deposit is loose and fern like, and most of it can be removed by knocking the cathodes against the sides of the jars. Gradually a firmer deposit collects that will not knock off, and this has to be removed with a scraper, when it comes away in sheets and leaves the cathode entirely clean. This pure silver is washed in centrifugal machine No. 1 until free from acid and soluble salts, and then is whirled until dry enough for melting, when it is made into fine bars.

A second product of this process consists of the slime that accumulates in the bottom of the cells. This contains black gold that has dropped from the anodes, as they dissolved, and also crystalline silver that failed to stick to the cathodes. This slime is transferred to the horizontal cells for retreatment.

(In some plants the anodes are incased in cloth bags, and the black gold is caught before it can drop to the bottom, and is melted for gold anodes, without further treatment.)

The operation in the horizontal silver cells is the same in principle as in the vertical, but the mechanical details are different. There are two independent sets of the horizontal cells, each having three cells in series. These show at the right-hand end of the first and second benches in Fig. 1. The anodes consist of the cores of the silver anodes from the vertical cells, the slime from the bottom of the vertical silver cells, and the silver reduced from the silver chloride slime from the gold cells. These materials are contained in a wooden basket or tray. The current is led into this mass by a "candle," made of equal parts of gold and silver, the lower end of which is buried in the material. The cathodes consist of graphite plates on the bottom of the cells. The crystalline metallic silver is deposited on these cathodes, and is removed at intervals with a long-handled dipper of hard rubber. The electrolyte is the same as for the vertical silver cells. The current is about 50 amperes, and passes through the three cells in series. This gives a current density of 14.3 amperes per square foot of cathode surface, and requires a potential of 5 volts per cell, or a total of 15 volts.

The baskets are made of maple, and all the joints are dovetailed, so that there is no metal in their construction. The bottoms are made with slats, and the baskets are painted all over with biturine solution. They are considerably smaller than the cells, so that the deposited silver can be scraped and gathered from the

cathodes through the space between a basket and the side of its cell.

The material to be treated is retained on five layers of 7-ounce duck placed in each basket, and the edges are brought up on all sides above the top of the basket. This cloth shows as a white frill around the tops of these cells in Fig. 1. The baskets are suspended in the electrolyte by cleats resting on the tops of the cells.

The material left in the basket, after all the silver has been dissolved, is crude or black gold, and is transferred to centrifugal machine No. 1 and washed. It is then dried in the dry room, melted, and used with other metal to make gold anodes for the gold process.

The spent electrolyte from both the vertical and the horizontal cells contains silver nitrate and the soluble nitrates of the base metals that were in the original bullion. These solutions and the nitric wash waters from the centrifugal machine are passed over scrap copper suspended in wooden tanks, which precipitates the silver and leaves the base nitrates in solution. These tanks are in the wash room, as shown in Fig. 3.

The precipitated silver is washed and dried in centrifugal machine No. 1, and then is melted and cast into bars. These are



FIG. 3. WASH ROOM, SHOWING CENTRIFUGAL WASHERS

added to melts of low-grade gold and made into silver anodes for the vertical silver cells. At times this precipitated silver has been dissolved in nitric acid to make silver nitrate for the electrolyte, but it is often impure, and a better electrolyte is obtained by dissolving pure silver; hence the practice is not common.

The solution containing the base nitrates is treated as described under the head of Copper Refining.

GOLD REFINING

The process tree, Fig. 5, gives an outline of the process of gold refining, and shows the sequence of events in a graphic form.

The Apparatus.—(a) The anodes, of the same size as the silver ones shown in Fig. 6, are made from high-grade gold bullion, and crude gold products from both the gold and the silver refining processes. They carry about 90 per cent. of gold and it is desirable that the silver content be limited to about 7 per cent., since a greater amount interferes with the operations. Copper is less objectionable than silver. The metal for the anodes is melted in the furnaces shown in Fig. 2. The anodes, hung by C-shaped hooks of pure gold from the conductors running across the top of the cells, are immersed 7.5 inches in the electrolyte.

* Volumetric Analysis, page 142, 7th edition (1896).

(b) The cathodes, strips of pure gold 4 inches wide by .012 inch thick (No. 28 B. & S. gauge), weigh about 4.5 ounces. They are bent over at the top, so that they can be hooked over the conductors opening the top of the cells. They are immersed to a depth of 6 inches, and are allowed to remain in the cells until they weigh about 160 ounces, when they are removed and used as the anodes for the second set of cells. By this redistribution the fineness of the final product is raised to about 999.7.

The gold is deposited on the cathodes so tightly that stripping is impracticable, and when the final cathodes have been formed, the deposit with its original cathode sheet is all melted down together. Hence, the original strips have to be made of pure gold in order to maintain the quality of the product.

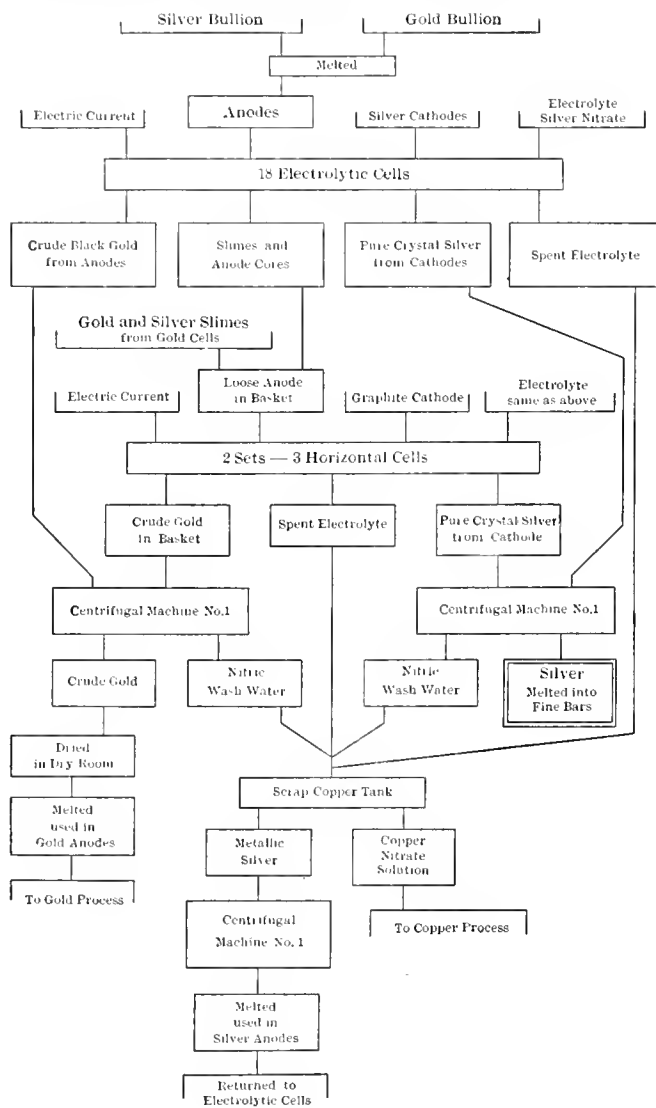

FIG. 1. DIAGRAM OF SILVER PROCESS

(c) The electrolyte is a trichloride solution, carrying in the first set of cells 70 grains of gold per liter, and from 10 to 12 per cent. of free hydrochloric acid, and in the second set, only 60 grains of gold per liter, but with the same amount of acid.

During the operation, the electrolyte decomposes and drops particles of metallic gold, which collect in the slimes. This lowers the strength of the solution in gold, and when it gets below 4 per cent. of gold, the deposit on the cathode is soft and tends to crumble. To prevent this, the bath is tested daily to determine its strength in gold, and if found to be low, is restored to the desired standard by the addition of strong solution.

The test of the electrolyte for gold is made with ferrous ammonium sulphate. A solution of this salt is made up of such strength

that 1 cubic centimeter of it will precipitate 27.5 grains of gold. Then, to a liter of electrolyte is added 3.5 cubic centimeters of $Fe(NH_4)_2(SO_4)_2$ solution, which is capable of precipitating 96.25 grains of gold—more than the bath is likely to contain. The excess of the ferrous salt is then determined by titrating with potassium permanganate, using a solution such that 1 cubic centimeter of $K_2Mn_2O_8$ will oxidize 1 cubic centimeter of $Fe(NH_4)_2(SO_4)_2$. On dropping the permanganate into the solution, its purple color is destroyed as long as any of the ferrous salt remains, but when the latter is completely oxidized, an additional drop will retain its color, indicating the end of the reaction.

After a week, the electrolyte becomes spent and takes on a dirty dark green color, due to the accumulation of copper salts in the solution. When it reaches this condition, the gold deposit on the cathodes is soft, and the electrolyte has to be changed.

The gold chloride for the electrolyte is made by dissolving gold bullion in hydrochloric acid by the aid of an electric current. Anodes of gold 990 fine are hung in strong hydrochloric acid, in five cells slightly larger than those used for the gold-refining process, and the cathodes, also of gold, are hung in porous cups filled with strong hydrochloric acid. On passing a current of 500 amperes at 25 volts through the cells, the anodes are dissolved, giving a solution of gold trichloride in the cells; but, owing to the porous cups, there is no gold deposited on the cathodes. Since hydrochloric acid fumes are liberated in the process, it is performed under a glass-enclosed hood connected to a flue, shown in the right background in Fig. 1. The gold chloride solution obtained from these cells has a strength of from 375 to 500 grains of gold per liter.

(d) The cells are of white royal Berlin porcelain, and have the dimensions shown in Fig. 8. The electrolyte, like that in the silver cells, already described, is kept in motion by one glass propeller in the center of each cell, revolved by a vertical glass rod.

The cells are placed in two rows, of 14 each, on a long bench. Those on one side form the first set, and those on the other the second set, for retreating the cathodes formed in the first.

The space between the adjacent cells is covered with a porcelain strip about 1 in. \times 3 in. in cross-section, clamped to the rim of the cells, and having a series of notches to receive the porcelain bars which support the conductors across the tops of the cells from which the electrodes are hung.

There are three rows of anodes and four of cathodes in each cell. The rows of anodes alternate with the rows of cathodes, and are $2\frac{3}{4}$ inches from center to center. There are two cathodes on each row, making eight cathodes per cell, and there are three anodes on each of two rows, but only two on the center row, making eight anodes per cell. The center anode is omitted to give room for the circulating propeller. The drive for the propellers is similar to that for the silver cells. The arrangement of these parts is shown in Fig. 1, where the gold cells (white) occupy the left foreground.

To the copper bus-bars, which are bolted to the top of the porcelain strips between the cells, are screwed the ends of the conductors that extend across the cells. These conductors are gold strips bent into an inverted trough shape, and fit the top of the porcelain cross-bars. The electrodes hang from these conductors.

(e) The current, a direct one of 15 volts potential, passes through the 14 cells of each set in series, as shown in Fig. 9, requiring nearly 1 volt per cell. The total amount of current is 180 amperes. There are eight cathodes in each cell in parallel, each having an immersed area of 4 in. \times 6 in. = 24 square inches. Four of the cathodes have both sides available for the reception of deposits, and four have only one side available, thus making 12 cathode surfaces of 24 square inches each, or a total of 2 square feet. The current being 180 amperes, the current density is 90 amperes per square foot of cathode surface.

(f) Centrifugal machine No. 2 is identical with No. 1, described under the silver process; but this one is used exclusively for gold products and material charged with chloride waters, which would precipitate silver chloride if it came into contact with solu-

tions of silver salts. A different filter bag is used for each kind of material. This machine is located in the wash room (Fig. 3).

(g) The drying room is of brick, has an iron door, is heated with steam and is built into one corner of the cell room. It is about 5 ft. X 6 ft. It shows in the central background of Fig. 1. It is used to dry fine gold cathodes and other gold products, before charging them into the melting pots.

(h) *Vats and Tubs.*—The vats used for the precipitation of the gold from the spent electrolyte are made of brown earthenware and stand on platform trucks for convenience in moving them about. They are 2 ft. X 4 ft. in area and 2 feet deep.

The tub used for the reduction of the silver chloride to metallic silver, by means of zinc and sulphuric acid, is made of wood, and lined with lead. It is 2 ft. X 4 ft. and 2 feet deep, and mounted on a truck similar to the earthenware ones.

Operations and Products.—Briefly, the anodes are dissolved in the electrolyte, and refined gold is deposited on the cathodes. All the metals in the anodes, including those of the platinum group, go into solution, except the silver and some lead. The last two form chlorides and drop to the bottom of the cells as the anodes dissolve. About 10 per cent. of the anodes is left as undissolved tops and has to be remelted.

It is desirable that the anodes should not carry more than about 7 per cent. of silver. When more than this amount is present, the coating of silver chloride that forms on the anodes is thick enough to retard the dissolving action. When the anodes contain less than about 7 per cent. of silver, they can be treated in a single set of cells, and the gold deposit on the cathodes will be considerably over 999 fine. But when more than 7 per cent. is present, so much silver chloride is formed at the anodes that, in dropping off, some of it is caught by the circulating currents and carried mechanically to the cathodes, where it clings to the rough surface of the gold deposit and lowers its fineness to less than 999. When handling such anodes high in silver, it has been found advisable to deposit the gold on the cathodes of one set of cells, and then transfer these cathodes after washing them to a second set of cells, where they are used as anodes and the gold is redeposited almost pure.

The gold anodes are made exclusively from the gold from the silver cells, which assays about 875 thousandths gold, from 100 to 125 thousandths silver, and a small amount of base metals. This gives, in the first cells, cathodes about 990.7 fine, which, on being re-treated in the second set of cells, produce gold about 999.7 fine. It has generally been considered necessary to boil the crude gold from the silver cells with concentrated sulphuric acid before casting it into anodes for the gold cells, in order to reduce the silver to less than 7 per cent. The desire to do away with this acid treatment and still produce a high grade of gold deposit led to the experiment of redepositing the first gold cathodes.

The same amount of current at the same voltage is used in both sets of cells. The electrolyte in the first set carries 70 grains, that of the second set 60 grains of gold per liter. With the exception of this difference in the strength of the electrolyte, the operation in both sets of cells is identical.

The gold cathodes from the second set of cells are carefully washed in a porcelain filter, dried in the dry room, melted and cast into fine bars about 1,000 ounces in weight, which may be sold as "mint bars," or alloyed with copper and made into coins.

The copper in the anodes goes into solution in the electrolyte; and as long as the proper amount of gold is maintained in the solution, it does no harm until the amount reaches about 4 per cent., when the gold begins to deposit soft and fall from the cathode. Then the electrolyte has to be changed.

The metals of the platinum group also dissolve in the electrolyte; and while they occur in such small quantities in the bullion that they can hardly be detected, the quantity accumulated in the solution by the dissolving of many anodes is quite appreciable, and is recovered as described later, under Copper Refining.

The silver in the anodes forms at the anodes insoluble silver chloride, a part of which, in the first set of cells, is removed at intervals by taking out the anodes and brushing and jarring off

the silver chloride into an earthenware jar. Most of the silver chloride, however, drops to the bottom of the cells.

The slime in the bottom of the cells also contains metallic gold, which comes from the decomposition of the electrolyte, and does not deposit on the cathodes. This decomposition of the electrolyte seems to be due to the displacement of its gold by the copper dissolved from the anodes. In the first set of cells, with anodes containing 10 per cent. of silver, the slimes are about 600 thousandths gold and 300 thousandths silver, and in the second set, with anodes almost free from silver, they are 960 thousandths gold and only 40 thousandths silver.

The slimes from the bottom of the cells, and the silver chloride that has been removed from the anodes, are washed free from

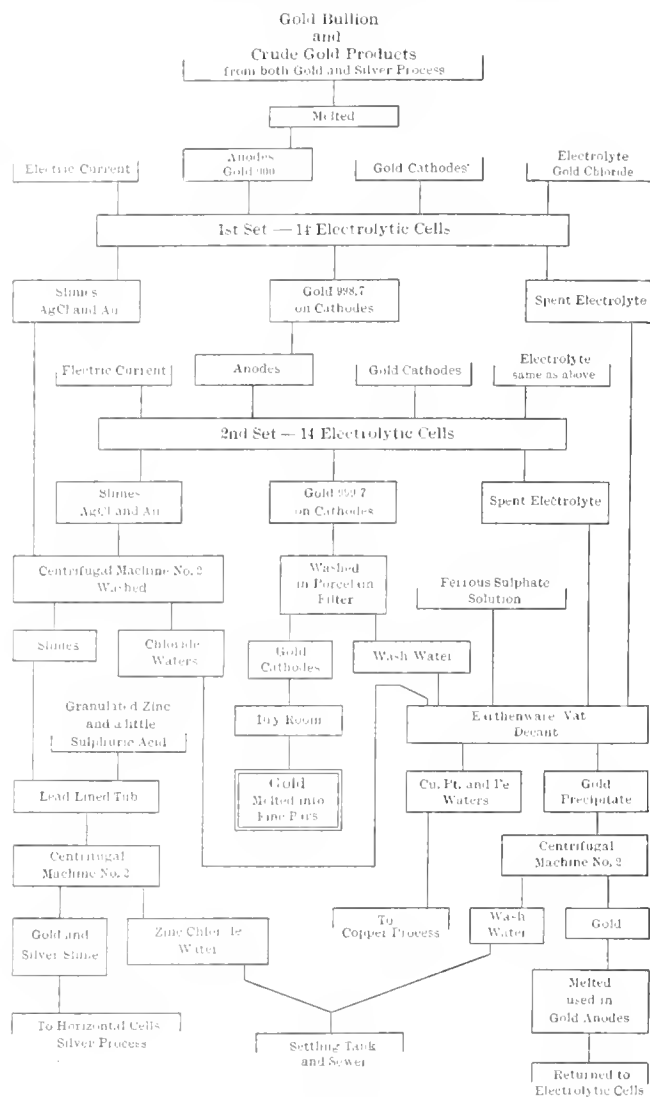

FIG. 5. DIAGRAM OF GOLD PROCESS

soluble chlorides in centrifugal machine No. 2, using hot water in order to carry off the lead chloride, and are treated in a lead-lined tub with granulated zinc, which precipitates the silver in a metallic condition, the zinc becoming zinc chloride. The granulated zinc is stirred into the mass of silver chloride and a little sulphuric acid is added to start the reaction. At first, the wet slime is a gelatinous mass characteristic of silver chloride, but as the reaction progresses it becomes more and more gritty. The mixture is tested toward the end of the process for the presence of silver chloride, and when there is no longer any present, sufficient sulphuric acid is added to dissolve any zinc that remains.

The test for silver chloride is made by treating a sample of the slime with ammonium hydrate, and then adding a few drops of

hydrochloric acid to the clear solution. If there should be any silver chloride present, it would be dissolved by the ammonia, and would reprecipitate on adding the hydrochloric acid.

The granular silver with its gold content, after being washed in centrifugal machine No. 2, to remove all soluble salts, is transferred to the anode basket of the horizontal cells of the silver

to the cells. This does away with the repeated melting and rolling of sheet-copper cathodes, similar to those of the precious metals used in the gold and silver processes. The cathodes are immersed 11 inches in the electrolyte and receive deposits on both sides. When completed, these cathodes are washed free of the electrolyte, dried, and added to melts of coin metal, without previous melting into bars.

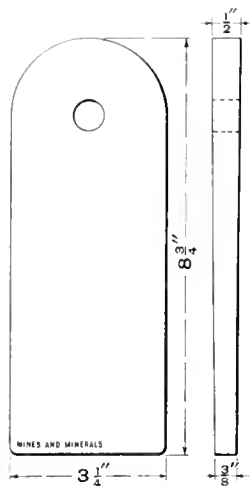

FIG. 6. DIMENSIONS OF ANODES

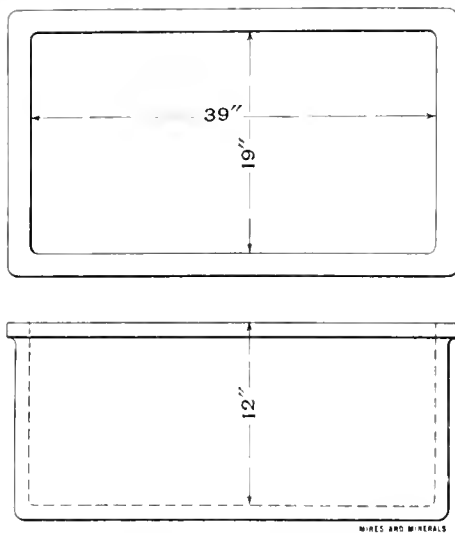

FIG. 7. SILVER CELL OF BROWN EARTHENWARE

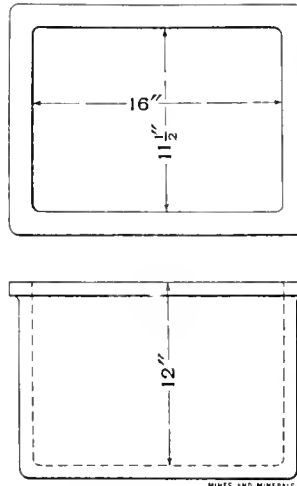

FIG. 8. GOLD CELL

process for the recovery of the silver; and the gold is afterwards obtained from the basket residue.

The wash waters from the slimes and from the gold cathodes, together with the spent electrolyte from both sets of cells, are placed in earthenware vats, and a concentrated solution of ferrous sulphate is added to the liquid. This precipitates the gold, which is allowed to settle by long standing. The liquor, which still contains platinum, copper, and iron salts, is decanted and sent to the scrap-iron tank for further treatment, as described later under the head of Copper Refining. The gold that remains after decantation is washed and dried in centrifugal machine No. 2, melted with low-grade bullion, and cast into anodes, in which form it reenters the process and is re-treated.

COPPER REFINING

This process is used at the San Francisco Mint to work up the copper occurring as base metal in the bullion, and to recover the copper used to precipitate the silver from the various wash waters. It is similar to the commercial process of copper refining; but it is of special interest here, because the metals of the platinum group, taken into solution in the previous operations, have now accumulated in sufficient quantities to be recovered. Fig. 11 shows the tree of the process.

The wash waters and spent electrolyte from all parts of the refinery, from which the gold and silver have been recovered, are sent to the scrap-iron tank and there deposit their copper, lead, and any precious metals, including those of the platinum group that have escaped from the previous operations. This tank is in the wash room (see Fig. 3).

The sludge of cement copper from this tank is washed and drained in wooden tubs with filter bottoms, whence it is transferred to other filter tubs and allowed to air dry, and then is melted down and cast into anodes for refining.

The copper anodes contain lead derived from the silver bullion, metals of the platinum group derived from the gold bullion, and small amounts of gold and silver. They are 5 in. x 14 in. x 3/8 in. thick, and are immersed 13 inches in the electrolyte.

The cathodes are started on sheets of lead 3.75 in. x 15 in., and when both sides have been coated with a copper deposit of sufficient strength, the copper is stripped off the lead and returned

The cells are lead-lined wooden boxes, 3 ft. x 1.5 ft. and 1.5 feet deep. Each cell contains 23 anodes and 34 cathodes, hanging in alternate rows, 2 inches apart from center to center.

The electrolyte is copper sulphate and contains 3 per cent. of copper as sulphate, and from 3 to 4 per cent. of free sulphuric acid. The cells are placed in a series of steps, so that the electrolyte flows through them by gravity. A steam ejector lifts the electrolyte from the sump at the lower end and returns it to the head tank, from which it again flows through the cells.

The current used is direct and has a density of 10 amperes per square foot of cathode surface, and a potential of 3.6 volts, which is equal to .6 volt per cell.

The gold, silver, and metals of the platinum group are insoluble in the sulphate electrolyte, and drop to the bottom of the cells as slimes when the anodes are dissolved. These slimes are collected, washed with dilute sulphuric acid, dried, and melted into bars. These bars are stored until sufficient have accumulated, when they are treated for the separation of the various precious metals, especially those of the platinum group, that they contain.

GENERAL REMARKS ON MINT PROCESSES

The Treasury Department maintains five refineries for the treatment of the gold and silver bullion deposited at the various mints and assay offices. The original installation in each case was the nitric acid process of refining. This was succeeded some 30 years ago by the sulphuric acid process, which in turn is now being displaced by the electrolytic process.

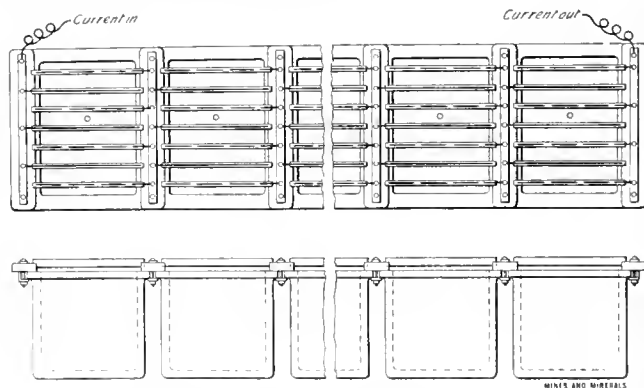

FIG. 9. PATH OF CURRENT THROUGH GOLD CELLS

The electrolytic process was installed in the Philadelphia Mint in 1902, in the Denver Mint in 1906, and in the San Francisco Mint in 1908. It will be used in the New York Assay Office upon the completion of the new building; and the refinery of the New Orleans Mint, where the amount of work is comparatively small, will then be the only government refinery using the sulphuric acid process.

The mints and assay offices accept bullion carrying more than 200 thousandths precious metals. The refining charges run from

1 cent an ounce on good silver bullion up to 8 cents an ounce on bullion carrying 800 thousandths base. The charges on ordinary gold bullion average 4 cents per ounce. On account of these high charges on very base bullion, most of it is sent to private refineries, where the facilities for handling this grade of material are better, and the refining charges are consequently less than at the mints.

In the silver process at the San Francisco Mint, the initial treatment of the bullion is in vertical cells. These are a modification, devised in the Philadelphia Mint, of the Moebius cells. The scraps from the vertical cells are retreated in the horizontal cells, which are a modification of the Thom cells. Both types of cells have their advantages and disadvantages.

For refineries where the silver bullion is the product of cupel furnaces, and carries less than from 50 to 60 thousandths gold, and not more than from 10 to 20 thousandths base metal, there is no question as to the superiority of the horizontal process.

In mint work the case is different. The bullion carries from 100 to 150 thousandths base and from 300 to 400 thousandths gold; the base requires an excess of acid to put it in solution, and the large amount of gold necessitates current for parting, in addition to that needed to dissolve the silver. The presence of the excess acid and of the heavy currents tends to destroy the filter cloths quickly.

The gold process used at all mints is the invention of Dr. Emil Wohlwill, of Hamburg, Germany, and was the outcome of experiments to separate platinum from gold. It was introduced by him into several refineries in Europe, and was first installed in this country in the Philadelphia Mint; but, so far as I know, no private refinery in this country is using it.

The electrolytic process of gold refining possesses three advantages that are important in mint work: (1) It produces purer gold than the old processes. The elimination of the last trace of silver from the gold removes the brittleness from the ingots used for coinage, so that they roll and press much better than alloys of the same fineness in gold, but made of slightly impure gold. (2) The process permits the saving of all the platinum metals without serious inconvenience. (3) The operations do not give off, as did former processes, great quantities of acid fumes, such as used to cause frequent complaints from the people living in the vicinity of the mints, which were all located in cities.

The electrolytic process of gold refining has three disadvantages as compared with the sulphuric acid process: (1) It is more expensive. (2) More care and intelligence are required to conduct it. (3) The losses are liable to be greater on account of having gold in solution in the electrolyte.

In mint work, the advantages more than offset the disadvantages; but in commercial work, the advantages mentioned are of less importance, and the large amount of precious metal invested in the process, with the resulting loss of interest, would be almost prohibitory of its use. This feature is not so important to the

Emil Wohlwill, *Electro-Chemical Industry*, Volume 11, page 221 and 261 (1901).

Robert L. Whitehead, *Electro-Chemical Industry*, Volume VI, pages 355 and 408 (1908).

Melting operations of various kinds at the San Francisco Mint are described by Harold French in *The Pacific Miner* for December, 1909, and for January, 1910.

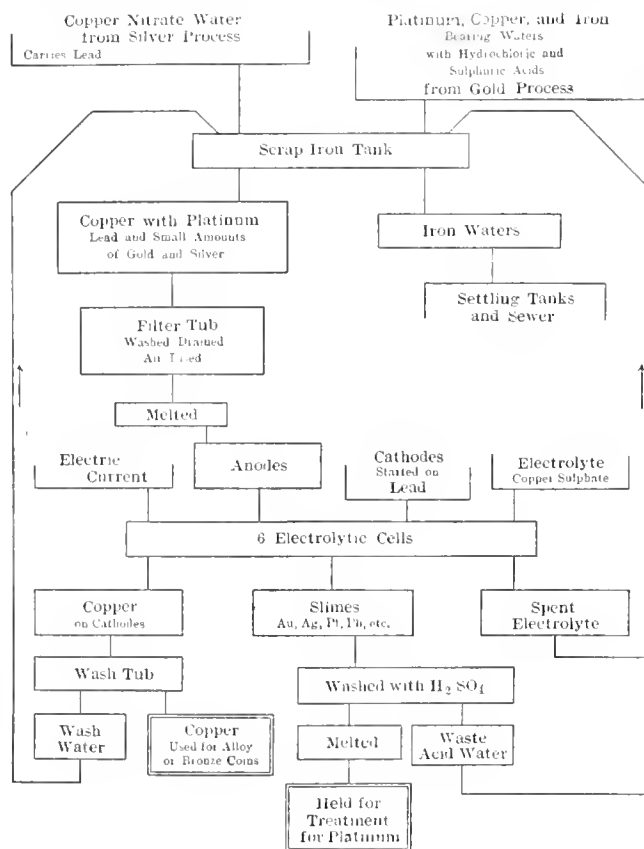

FIG. 11. DIAGRAM OF THE COPPER PROCESS

ACKNOWLEDGMENT

As already mentioned, I collected the notes from which this paper is prepared in December, 1909, and I wish to acknowledge the courtesies which were extended to me by E. R. Leach, melter and refiner, in showing all parts of the process, and in answering numerous questions. Mr. Leach has also furnished the photographs and lent his aid by valued criticism, both of the text and of the illustrations.

來 來

Slate and Marble in Newfoundland

The slate deposits of Newfoundland for roofing and other purposes are at Trinity Bay, about 120 miles by rail and steamer north of St. Johns. According to the United States Consular Report, they are 600 to 800 feet in width, and extend for miles; 75 per cent. of the slate is a bright purple, and the remainder of an attractive grayish green. They belong to the same geological formation (Cambrian) as those of North Wales. The geographical position of these deposits, being so near the Atlantic steamship routes, commands an exceptionally favorable position for the export of their products to the American and European centers of consumption.

A large deposit of marble occurs within a few miles of one of the arms of Bay of Islands, on the west coast of Newfoundland, according to the United States Consular Report. The deposit is 250 feet or more in width, and extends at least 2 miles in length. The marble is of a beautiful cream color when polished and has been pronounced by competent marble workers to be equal to the best Italian.

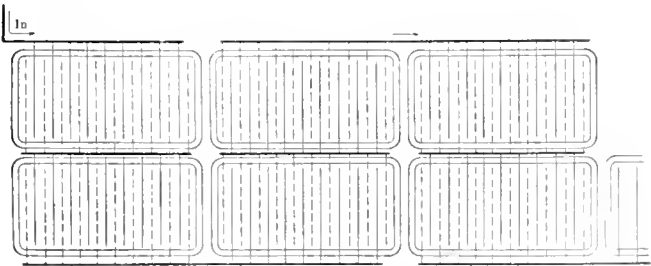

FIG. 10. PATH OF CURRENT

government, as the metal so tied up may be considered as part of the gold reserve, and is accounted for at the time of annual settlements.

REFERENCES

Electrolytic refining of gold, silver, and platinum is treated in the following articles:

D. K. Tuttle, *Electro-Chemical Industry*, Volume I, page 157 (1903).

Estimating Alkalinity in Lime

Rapid Method of Determining the Exact Value of Lime Used in the Cyanide Process

At the meeting of the American Institute of Mining Engineers, San Francisco, Assistant Professor Luther W. Bahney, of Stanford University, California, presented a paper entitled "Rapid Estimation of Available Calcium Oxide in Lime Used in the Cyanide Process," from which the following is abstracted:

Lime is the alkali that is most universally added to solutions in the cyanide process of gold and silver extraction, for maintaining the so-called "protective alkalinity." It is produced by calcining limestone, and therefore varies in the percentage of calcium oxide which it contains according to the purity of the limestone. The value of lime as an alkali depends upon the purity of the limestone, the temperature and period of calcining, the length of time it has been stored, and whether it has been subjected to dampness. Good quicklime can be purchased in the United States from reliable producers, but in Mexico and Central America, where it is apt to be poorly made, the quality is quite variable.

In consideration of the foregoing, it is apparent that there is need for a rapid method of the valuation of lime to be used in a cyanide plant. The determination of a calcium by the gravimetric method requires too much time and is too complicated for an isolated plant. The calculation of the calcium so found to calcium oxide, although sometimes done, is inaccurate.

Several methods of titration by means of a standard acid have been described, and no doubt give results sufficiently accurate for a technical method, but the objections to these methods are that they involve the preparation of a standard solution of some acid, usually decinormal hydrochloric acid, which cannot be weighed out, but must be standardized with some other standard solution. Solutions of the following acids have been used by different operators for standardization: sulphuric, nitric, hydrochloric, and oxalic. Oxalic acid is perhaps the most favorable for this purpose, because a standard solution can be prepared by weighing the solid acid and dissolving in water. The use of the solution employed to determine the alkalinity of the cyanide solutions has also been suggested.

While the method of standardization with oxalic acid is open to the objection that the hydration of the acid may vary somewhat, yet it yields a solution sufficiently accurate for technical work, but so far as I am aware its use has not been suggested.

For the purpose of determining the feasibility of using oxalic acid, the crystals were dissolved in distilled water, and a decinormal solution made. A decinormal solution of pure hydrochloric acid with distilled water was also made, and both were standardized with a solution of chemically pure sodium carbonate.

Pure calcium oxide was prepared by grinding pure white crystals of calcite in an agate mortar and igniting the fine material in a platinum crucible over a strong blast until constant weight resulted.

This oxide, cooled in a desiccator, was ground in an agate mortar to pass 200 mesh, and the percentage of calcium oxide determined gravimetrically; the result was 99.98, as compared with the theoretical 100 per cent.

The calcium oxide so prepared was used as a standard throughout the succeeding tests. Similar weighed portions were titrated with decinormal hydrochloric acid and oxalic acid, using phenolphthalein as an indicator, requiring 44.2 cubic centimeters of hydrochloric acid or 44.6 cubic centimeters oxalic acid to complete the reaction.

The solution of oxalic acid used in the subsequent experiments was made by dissolving 14.6068 grams in enough distilled water to make a liter, this strength being recently suggested for determining the protective alkalinity of cyanide solutions.

The first experiments were made upon small amounts of 140 milligrams of lime, to which was added 100 cubic centimeters of water

before titration, the idea being to have just enough lime present to be theoretically soluble in that amount of water.

This quantity is somewhat small to handle conveniently, and the published method* of weighing out 14 grams, making 1,000 cubic centimeters of emulsion, removing 100 cubic centimeters, and again diluting to 1,000 cubic centimeters and removing 100 cubic centimeters for titration, did not give results which checked upon low-grade limes; moreover, this latter method is open to the objection of extra manipulation. A larger amount was then tried, introduced directly to a flask in which the determination was to be made.

The weight of lime to be taken was calculated so that each cubic centimeter of oxalic acid solution would represent 1 per cent. of calcium oxide, as given in the formula:

$$\text{Lime} \quad \text{Lime} \quad \text{Oxalic} \quad \text{Oxalic} \\ 56.09 : x :: 126.048 : 14.6068, \text{ in which } x = 650$$

This weight, 650 milligrams, was used in all the tests, and Table I shows the results, which are sufficiently satisfactory for a technical method.

The titrations were made in the cold by introducing 650 milligrams of the sample into a 300-cubic centimeter Erlenmeyer flask containing 50 cubic centimeters of distilled water, using phenolphthalein as an indicator.

TABLE I. RESULTS OF TITRATION FOR CALCIUM OXIDE, USING OXALIC ACID

Calcium Carbonate Present Per Cent.	Calcium Oxide Present Per Cent.	Calcium Oxide Determined Per Cent.	Calcium Carbonate Present Per Cent.	Calcium Oxide Present Per Cent.	Calcium Oxide Determined Per Cent.
95	5	5.2	45	55	54.5
90	10	10.3	40	60	59.9
85	15	15.3	35	65	64.8
80	20	20.3	30	70	69.6
75	25	25.0	25	75	74.5
70	30	30.2	20	80	80.2
65	35	35.0	15	85	84.8
60	40	40.0	10	90	90.0
55	45	45.0	5	95	94.7
50	50	49.8	0	100	100.0

The results given in Table I indicate that calcium oxide in the presence of calcium carbonate can be determined by this method with a fair degree of accuracy.

Silica, present in most limes, does not interfere. Magnesia, also present in most limes in greater or less amount, is very slightly soluble in water†, and shows a faint reaction with the indicator; but it is of no value as an alkali in cyanide work and should not be shown in a determination of the available alkali in lime to be used for that purpose.

Fortunately, the point where the alkalinity due to calcium oxide stops is readily recognized after a little practice, for the color is a vivid pink, while that of magnesium oxide is faint. Moreover, the color in the titration of magnesium oxide disappears with the addition of only .1 or .2 cubic centimeter of oxalic acid solution, and returns very slowly and feebly, while that of lime is rapid and sharp. This is illustrated by the fact that a titration of pure calcium oxide requires only 5 minutes, while the same amount of magnesium oxide requires 3.5 hours.

In order to test the oxalic acid titration in the presence of magnesia, two samples of limestones containing magnesia were ground to 200 mesh, ignited in a platinum crucible to constant weight, and titrated. The calcium oxide in each sample was determined by the gravimetric method, since there was no silica present, and only a trace of iron. The following results were obtained:

	Amount of CaO by Gravimetric Method Per Cent.	Amount of CaO by Oxalic Acid Method Per Cent.
Sample No. 1	57.6	57.6
Sample No. 2	50.4	51.0

* Treadwell and Hall, Vol. II, page 453.

† Comey's Dictionary of Solubilities.

These results indicate that the magnesia does not interfere. Its presence can be judged by the behavior of the titration, and the approximate amount can be quite accurately estimated by continuing the titration, if one has the time needed.

Iron oxide in considerable amount is sometimes present in impure limes, and it obscures or masks the color of the indicator, but if the precipitate be allowed to subside, the titration may be carried out to within 1 per cent. of the correct result.

The determination of the amount of carbonate present in an imperfectly burned lime may be carried on as follows: Grind the sample to pass 200 mesh, weigh out 650 milligrams and make the titration in the usual manner; call this result No. 1, "Available Calcium Oxide." Ignite 650 milligrams of the finely ground sample in a muffle or over a blast lamp, and make a second determination; call this result No. 2. Subtract No. 1 from No. 2, divide by 1.78, and the result will be the amount of carbonate present.

Details of the Method.—The sample must be ground to pass through a 200-mesh screen. Into a 300-cubic centimeter Erlenmeyer flask place 50 cubic centimeters of distilled water; then add the 650 milligrams of the finely ground sample, stopper the flask, and shake vigorously for 10 seconds; add two drops of solution of phenolphthalein, and then run in the standard solution of oxalic acid until the pink color is discharged; then replace the stopper and again shake. When the color returns, if it is due to lime it will be a bright, vivid pink, and the addition of perhaps .5 cubic centimeter of solution will be necessary to discharge this color, but if the flask is again shaken and the color is a faint, weak pink returning slowly, this is the endpoint for the lime, and indicates that the magnesia is asserting itself.

At all times during the addition of the oxalic-acid solution the flask should be violently shaken, being careful not to allow any of the solution to splash out, so the calcium oxide will pass into solution. In nearly every instance of titration of a high-grade lime, the pink color remained vivid nearly to the finish, which shows that the calcium oxide is rapidly soluble.

If a complete titration is allowed to stand for from 15 to 30 minutes the pink color will return and show as brightly as in the beginning.

The reading of the burette is in percentage of calcium oxide.

The solutions necessary are: Oxalic acid, 14.6068 grams pure crystals dissolved in enough water to make a liter of solution. Phenolphthalein, .5 gram dissolved in 50 cubic centimeters of alcohol and 50 cubic centimeters of water.

采 采

In a recent report of the United States Geological Survey it is stated that the world's production of bauxite in 1909 totaled 270,581 tons valued at \$949,924, of which the American share was 128,099 tons worth \$251,188.

President Taft in the Homestake Mine

By A. J. M. Ross*

While making an extensive tour through the country President Taft received an invitation from T. J. Grier, general superintendent of the Homestake Mining Co., Lead, S. Dak., to examine the underground workings of the mine when he visited the town.

The President arrived in Lead on the afternoon of October 21, and after a short address to the people, assembled in the Hearst Free Kindergarten grounds, he was presented by the citizens of Lead with a gold candlestick. He was then driven to the Ellison shaft, the largest in the state, and escorted through the mine by a committee composed of T. J. Grier, general superintendent; R. Blackstone, assistant superintendent and chief engineer; B. C. Yates, assistant chief engineer; W. S. O'Brien, general mine foreman; R. L. Daugherty, State Mine Inspector; and others. The descent was made to the 1,100-foot level and a course taken toward the Golden Star shaft, stopping first in a stope where a

large Ingersoll machine, set up on the sill floor, was drilling a n "upper." The next stope visited is 360 feet long by 60 feet wide by 110 feet high, the west 180 feet being shoveled clean of broken ore, while the east 180 feet is full of broken ore. This chamber was illuminated from openings on the 1,000-foot level by burning magnesium ribbon, thus giving the President an excellent opportunity to view one of the largest stopes in the world. On the pile of broken ore a block holing machine was drilling a large rock for blasting into small pieces. The pump room at the Golden Star shaft was next visited, and just before the party was hoisted at this shaft the photograph was



FIG. 1. PRESIDENT TAFT IN HOMESTAKE MINE

taken from which Fig. 1 was reproduced. The President traveled a little over half a mile on the 1,100-foot level and seemed thoroughly interested in all he saw. The Homestake mine is one of the oldest gold mines in the United States. Its operation has made history, and although it has had vicissitudes in plenty, nevertheless it has paid over \$21,000,000 in dividends. The success attained in operating this mine has not been due to the richness of the ore, but to the vast sums of money expended to carry on the operations on a large scale.

Probably no other gold mine has so large and expensive equipment, or works low-grade ore to such advantage.

采 采

The principal mining fields of Peru are confined to the Andean Cordilleras and the coast ranges. The industry is scattered over a possible total area of 150 to 200 square miles. The distribution, according to the claims paying taxes, appears to be gold, copper and silver, silver, petroleum, copper, coal, and, to a much less extent, bismuth, mercury, vanadium, tungsten, nickel, antimony, iron, sulphur, salt, and peat.

Exhaust Steam Turbines at Mines

Method of Utilizing Part of the Power Ordinarily Lost in Exhaust of Reciprocating Engines

The following paper, under the title "Applications of Exhaust-Steam Turbines to the Power Plants of Mines," was presented by John C. Cunningham to the Australasian Institute of Mining Engineers, in June, 1911:

The cost of power is an important matter to mining companies generally, and the thought that the members of the Australasian Institute of Mining Engineers, as well as the engineering and mining profession generally would be interested in any proposal for the reduction of the cost, has led to the presentation of this paper.

In the working up of the electrical data the author has had the able assistance of F. J. Mars, to whom he offers his hearty thanks.

The selection of the best class of power plant for a mine is a difficult and large problem and it is quite out of place to dogmatize that any one of the many systems that offer is better than another; for example, that the all-electrical is better than the partly direct steam driven and partly electrical, or that a gas plant is better than a steam plant. A selection calls for careful consideration, in each particular case, of a large number of factors.

This paper deals with some factors that control the application of exhaust-steam turbines to existing steam power plants of mines, in order to reduce the cost of producing power, where, on account of excessive capital outlay, general impracticability, or poor economy, the decision has gone against other proposals, which entailed the introduction of complete new plant.

It will be apparent that where fuel and water costs are high a greater monetary reduction of the cost of producing power is possible than in localities where fuel and water are cheap. The importance of this will be better understood when it is stated that the cost of producing power in Broken Hill can be reduced by exhaust turbines from 15 per cent. to 35 per cent. in mines where the present annual power cost runs to, say £30,000, £40,000, or even £50,000 without exhaust turbines.

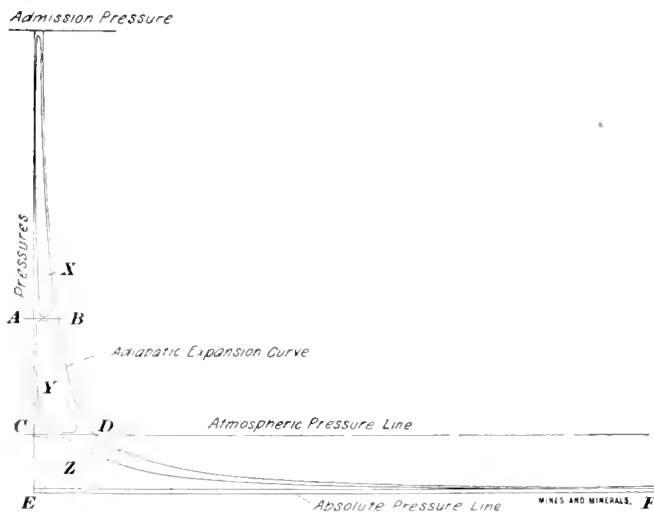

FIG. 1

In a number of the mining districts fuel and water are expensive and probably in many of them the exhaust turbine could be applied with advantage.

For those who are not conversant with turbines, it might be well to explain here why they are able to increase the efficiency of steam plants and so reduce the total cost of power required.

Fig. 1 represents the pressure-volume diagrams of a compound non-condensing engine and attached turbine. *AB* is the volume of the high-pressure cylinder, *CD* is the volume of the low-pressure cylinder, and *EF* is the equivalent volume of an exhaust turbine.

The diagram *X* above the line *AB* represents the actual work done by the high-pressure cylinder, *Y* that of the low, and *Z* that of the turbine.

The work done by each of the above is by the admission and the expansion of the steam from boiler pressure down to about atmospheric in the engine, and from that pressure in the turbine

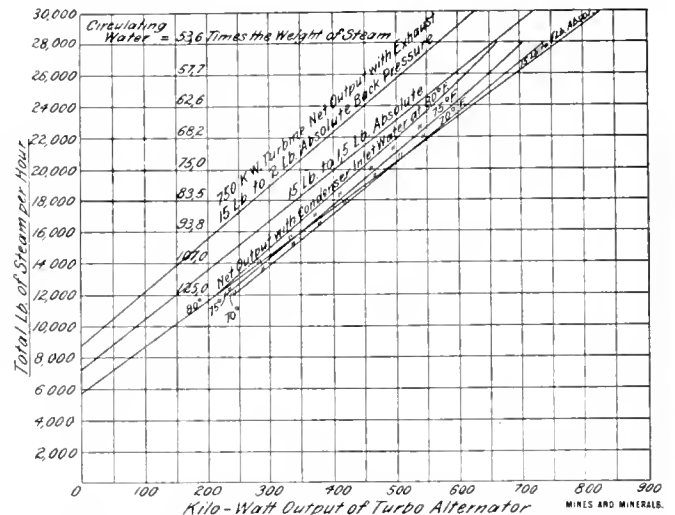

FIG. 2. EFFECT OF TEMPERATURE OF CONDENSER INLET ON VACUUM AND NET OUTPUT OF AN EXHAUST TURBINE WITH COOLING TOWER IN CIRCUIT

down to the vacuum, or absolute back pressure prevailing in the condenser.

It will be noted that the volume of this high-pressure cylinder at admission is one-fifth that of the total low-pressure volume. It will also be noted that the volume of the low-pressure cylinder is about one-eleventh of the equivalent volume of the turbine; in other words, the engine would require another cylinder 11 times the size of the low pressure in order to reap the advantage from expanding steam to the final pressure prevailing in the condenser. For several reasons, largely mechanical ones, such a large low-pressure cylinder is impracticable, and so the turbine has grown in favor during the last 10 years.

The efficiency (or work done for a given expenditure of heat) of a turbine, increases with the vacuum or reduction of absolute back pressure. Fig. 2 shows that by decreasing the back pressure from 2 pounds absolute to 1 pound absolute, the net output with 12,000 pounds steam per hour is increased from 95 kilowatts to 210 kilowatts, or 120 per cent., while with 28,000 pounds steam per hour, it increases from 560 kilowatts to 760 kilowatts, or 36 per cent. This may be expressed another way. For a net output of 200 kilowatts a steam supply of 15,000 pounds per hour is required with a 2-pound absolute back pressure, and 11,700 pounds with 1-pound absolute back pressure, or a saving of 25 per cent. Again for a net output of 600 kilowatts the relative steam consumptions will be 29,100 and 23,300, or a saving of 20 per cent. The back pressure which can be maintained with advantage will depend on the amount of power that must be expended for the production of such a back pressure.

The temperature of the condenser cooling water controls the amount of power required, and where cooling systems have to be used, climatic conditions, as well as design of cooling tower, regulate the temperature of the cooling water and the power required to produce that temperature.

All mines that use steam power apply it generally for somewhat similar purposes and probably all these applications can be classed under the following headings: Electric power generating engines (constant speed); air-compressing engines (variable speed); winding and hauling engines (intermittent and variable speed); pumping engines (various types); plant-driving engines (constant speed).

In the majority of these applications the engines are run non-condensing, and in some cases where the engines are run condensing it will be advantageous to discontinue doing so and install a turbine and suitable condenser to utilize the steam from these and other non-condensing engines.

The power generated by such turbines is almost invariably transmitted to an electrical generator in order that the power may

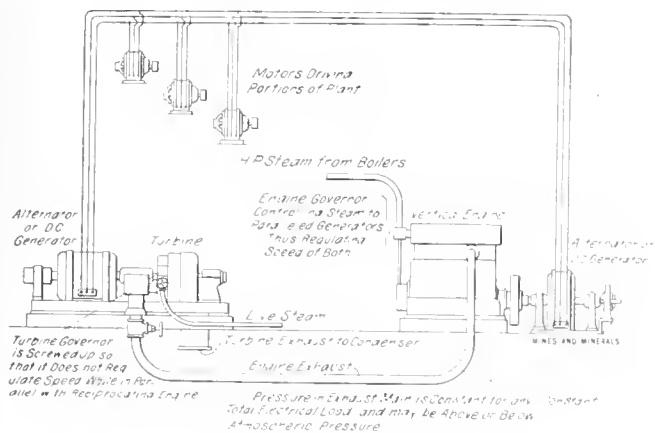

FIG. 3

be distributed electrically through motors where required. In some cases, however, the turbine has been coupled direct to a rotary blower, or compressor for compressing air or other gases; but the present efficiency of such compressors is not so good as the reciprocating compressor, and therefore for mining purposes they do not appear to be suitable, except where exhaust steam is available, which would otherwise discharge itself into the atmosphere.

Of the several classes of reciprocating engines enumerated, the exhaust from electric power generating engines is more easily applied to turbogenerators than any of the others, on account of the ease with which steam supplies can be regulated to both engine and turbine, as shown in diagram Fig. 3. The reason for this is that when the engine and turbogenerators are run in parallel, the turbine governor valve is adjusted for a higher speed, causing the engine governor alone to regulate the supply of steam to the paralleled engine and turbogenerators. It will be recognized, with this arrangement, that the paralleled generators act as a coupling between the engine and turbine, thus making the turbine the amplified low-pressure cylinder, to which reference was made in explaining Fig. 1.

The utilization of the whole of the exhaust from plant-driving engines in a turbogenerator is not so easily done on account of the lack of the electrical link which was present in the last case. For the same reason and also on account of the intermittent flow of the exhausts, the application of the turbogenerator to utilize the whole of the exhaust steam from air-compressing engines, pumping engines, and particularly winding engines, is not so easy as in the case illustrated in Fig. 3.

With all these five types of engines, some of the exhaust of any number or all of them may be utilized in a turbogenerator of the size required to suit ordinary power and lighting requirements. With the arrangement shown in Fig. 4 there will at times be an excess of exhaust steam, which must be allowed to escape to the atmosphere, through the automatic relief valve.

In order to store some of the heat which is lost through the relief valve, during periods of excessive steam supply, pending periods of insufficient steam supply, several forms of accumulators have been utilized.

In nearly all of these some advantage is taken of the increased heat units that can be stored within any given volume, by an increase of the pressure in the exhaust main and accumulator, to the extent of from 2 to 4 pounds per square inch. This storage is due to the increased temperature and density of the steam, brought about by an increase of pressure, as shown in Table 1.

TABLE 1. STEAM ACCUMULATOR TABLE

Absolute Pressure Per Square Inch	Volume Per Pound in Cubic Feet	Total Heat Per Pound of Steam From 32° F.	Accumulation Due to Pressure B. T. U. Per Cubic Foot of Steam	Temperature of Steam Degrees F.	Accumulation Due to Temperature of Water Absorbed B. T. U. Per Cubic Foot of Water 32° F.
15	25.85	1146.9	44.36	213.1	11,318.7
15	21.78	1149.8	52.78	222.5	11,906.3
Increase in B. T. U. per cubic foot of accumulator volume			8.42		587.6

The storage or accumulation due to increased density is instantaneous, but that due to increased temperature is relatively slow and depends on the rate of absorption of the heat by the water or iron which forms the storing body.

It will be apparent that as the absorption of heat cannot be instantaneous, considerable quantities of exhaust steam must still escape through the relief valves to the atmosphere, as in the case shown in Fig. 4.

Large gasometer forms of accumulators could be utilized, but this may not be practicable, and the capital expenditure makes it prohibitive.

With accumulators of the Rateau type, a turbine, during periods of no exhaust steam, will run for about 1 minute on full load before high-pressure steam becomes necessary, owing to a drop in speed.

With a view of eliminating some of the loss that takes place through the escape of steam from the accumulator to the atmosphere in the various cases already dealt with, the following application of the turbogenerator has suggested itself for mines, where the amount of the exhaust from the intermittent and variable-speed engines is sufficient in quantity and frequency to give an improved total fuel economy when utilized in the turbine.

With the arrangements shown in Figs. 5 and 6 no accumulator is required and with proper design and under normal operative

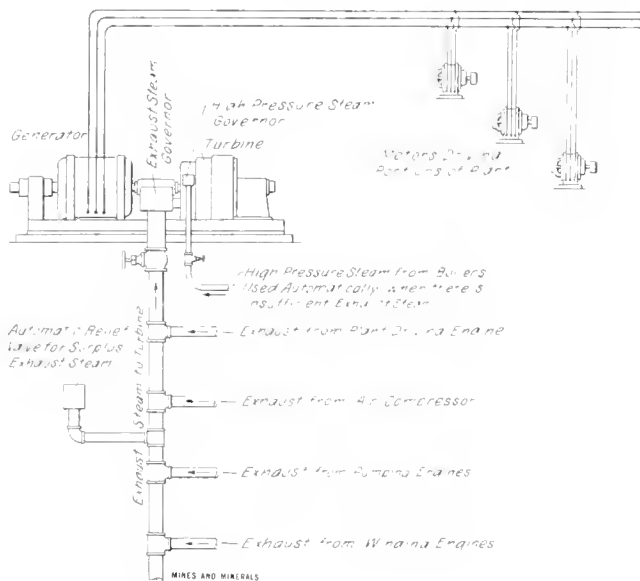

FIG. 4

conditions, the whole of the exhaust steam is utilized. The system may be described as the electrical coupling or paralleling of some of the constant-speed plant-driving engines, with the exhaust turbogenerator, by means of electric motors on the engine shafts or countershafts, so that when the intermittent exhaust steam from the other engines is admitted into the exhaust main, the turbine speed will at once rise, and, through the motors, raise the speed of all their controlled engines. In doing so it will share their loads and

so regulate the amount of live steam passing into these engines through their governor valves and thence from the engine to the exhaust turbine.

In this way excessive rise of pressure in the exhaust main is prevented and consequently loss of steam through the atmospheric relief valves is avoided.

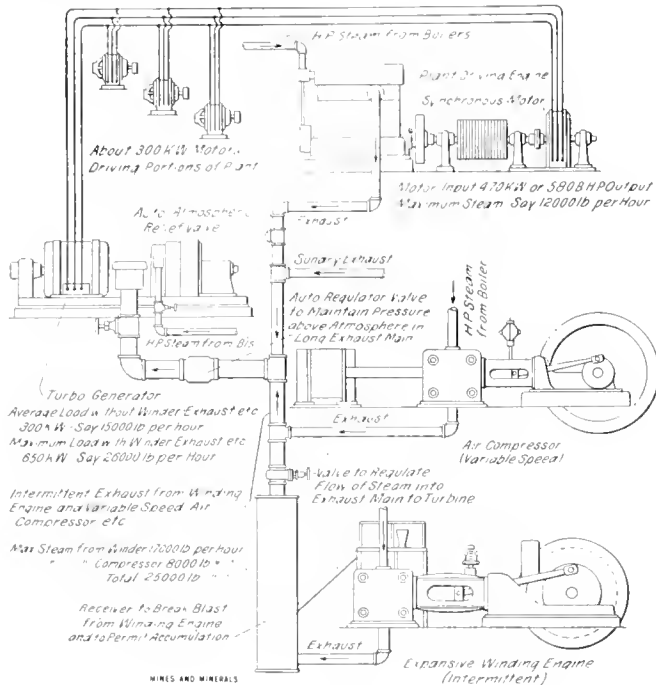

FIG. 5

Of course, in order to obtain this result, certain conditions must exist, some of which are as follows:

1. The turbine and generator must be of sufficient size to generate power from the maximum amount of exhaust steam from the intermittent and uncontrolled engines.
2. The motors on the controlled engine shafts or counter-shafts must be large enough collectively to utilize the increased output from the turbogenerator during the periods of maximum exhaust from the uncontrolled engines.
3. The maximum amount of exhaust from the motor-controlled engines should bear such ratio to the maximum amount from the uncontrolled engines, that the latter can be wholly utilized without excessive pressure in the exhaust main and a possible loss through the relief valves.
4. The average amount of exhaust from the motor-controlled engines should be approximately equal to generating the average electrical power requirements which prevail when the uncontrolled engines are not in operation, in order to avoid the uneconomical use of high-pressure steam in comparatively small turbines of 750 to 1,000 kilowatts.

All of these conditions may be followed in the figures shown in the diagram, Fig. 5, which seems to be a system that must prove particularly suitable where the mine plants are of sufficient size and in lay-out lend themselves to this form of application.

Continuous- or direct-current generators and motors can be arranged to serve as the electrical link and controller for the system, but commutation troubles in the motors, and particularly in the turbine generator at voltages of 600 or more, coupled with the difficulty in closely determining and fixing the relative speeds of motors and generators, does not make such a good arrangement as can be obtained with alternating-current systems.

Where dust is present, the alternating-current systems have decided advantages over direct-current systems and their attendant commutators.

With three-phase alternating systems, either the synchronous motor or the asynchronous or induction motor is used. With the

first type, the speed of revolution must vary exactly with any variation of the phase speed of the synchronous generator, but with the induction motor the speed does not vary exactly with the generator under all load conditions. Fig. 7 shows approximately the speed effect or slip which load has on induction motors and generators; and it also shows that an induction generator must run above the phase speed of the synchronous generator with which it is in parallel before it can share the electrical load.

Referring to Fig. 5 it will now be clear that the increase in turbogenerator phase speed required to cause the plant-driving engine governor to close (when large quantities of exhaust steam flow from the winding engine, etc.), must be much greater where an induction motor is applied than is required with a synchronous motor. The latter type is therefore preferable.

For general mining work, a slight periodical variation of from 2 to 3 per cent. in the phase speed of all generators and motors is not at all objectionable, provided that an automatic voltage regulator be utilized.

Possibly the only class of machines that would be influenced to any extent are centrifugal pumps, which would throw increased quantities of water with every increase of speed. This feature may be advantageous where centrifugal pumps are used for circulating the water through the condensers.

It will be obvious that the governors of all the engines fitted with controlling motors (Figs. 5 and 6), must act with but a small speed variation, and generally be similar to those on the reciprocating engine and the turbogenerator sets.

An advantage of some importance in the arrangement shown in Figs. 5 and 6 is that, in the event of a breakdown of any of the controlled engines, they may be disconnected and the plant may be run by the synchronous motor alone, provided with a squirrel cage or other suitable winding in the motor, or an auxiliary motor be provided for the ready starting up of the synchronous motor.

The increased total electrical load under these conditions

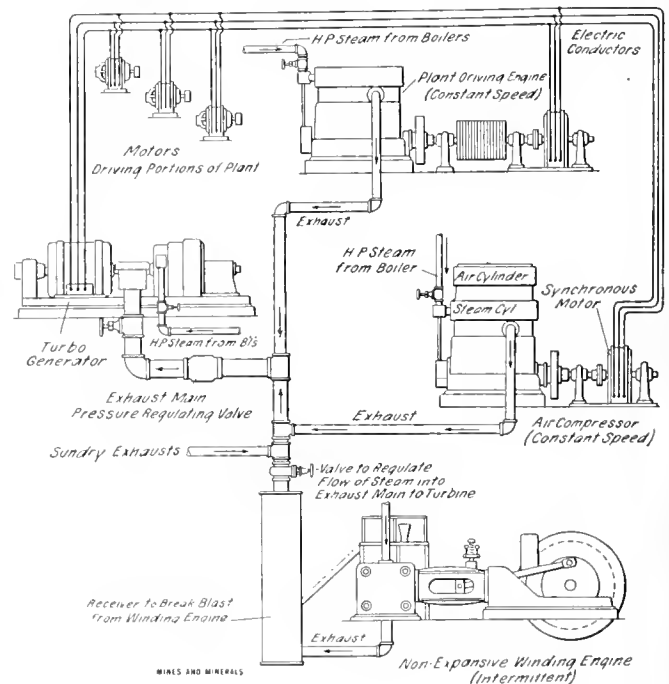

FIG. 6

would be met by a stand-by engine generator or by high-pressure steam in the turbine.

In using synchronous motors advantage should be taken of the opportunity to improve the power factor in the generators, and in the lines connecting the motors and generators, by over-exciting the field on the synchronous motors.

Where the load on the generators is an inductive one, power factors of from 85 per cent. to 70 per cent. or lower may obtain,

which will reduce the power capacity of the alternator proportionately. By over-excitation of a synchronous motor, power factors of nearly 100 per cent. can be obtained in the line and generator and give increased maximum carrying capacity of generator.

Alternators which may not be required when turbine is added to the power plant can be converted to synchronous motors for the

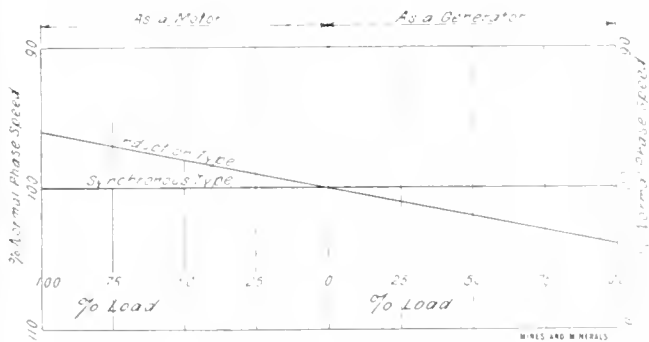

FIG. 7. SHOWING RELATION BETWEEN SPEED AND LOAD OF MOTORS OF THE INDUCTION AND THE SYNCHRONOUS TYPE

electrical linking of plant-driving engines with the turbine under the system shown in Fig. 6.

In many mining plants the distance of the exhaust steam sources from the exhaust turbine may be excessive, and doubt will arise as to the advisability of conveying it to a central turbine. Problems of such a sort can only be solved on the spot, some of the regulating factors being size of main, amount of steam, climatic conditions, etc., but the careful covering of the main by good non-conducting material will permit the use of mains of considerable length up to say 500 feet or more.

Where long mains are unavoidable, the certainty of the pressure in the main falling below atmospheric pressure, when the turbine is running on low load, may cause trouble through the leakage of air in large quantities through the joints into the system.

The effect would be to overtax the air pumps, with a reduction and possibly total loss of vacuum and might cause the whole power system to drop in speed or drop out of parallel.

It will be noticed that Fig. 6 is very similar to Fig. 5, the difference being that the former shows two units and the latter one, in which the supply of exhaust steam is regulated through the agency of synchronous motors. This will convey and express what must be arranged for when the maximum supply of steam from the uncontrolled engines is more than is required by the turbine to generate all the power demands of the induction and synchronous motors shown in Fig. 5.

Steam must be used expansively if it is to be used economically. Expansion has been applied to some winding engines, and actual cases indicate that a reduced steam consumption, amounting to about 65 per cent. of that consumed by the ordinary piston-valve winder, can be effected. It will be clear, therefore, how important is the steam economy of the winding engine to the mine that contemplates installing an exhaust turbine on the system illustrated by Fig. 5, particularly where the winding-engine exhaust constitutes a fairly large proportion of the total exhaust steam available from all sources.

The increase in efficiency of a steam plant fitted with an exhaust turbine is expressed by the diagram shown in Fig. 8. The same diagram also conveys some idea of the low efficiency of what are called modern high-class steam power plants.

The writer is sure that many will be rather taken aback by this graphic representation of the heat balance sheet, even as he was when he first perused it in a catalog of the Allgemeine Elektrizität Gesellschaft.

The diagram has been calculated and set down to represent approximately the average mining plant, where long steam and exhaust mains are general.

It has been pointed out that a turbine excels a reciprocating engine by virtue of the expansion which can be given to the steam

at low pressures. At high pressure and down to atmospheric, the high-class reciprocating engine is at present a more economical heat engine than the turbine, but the advisability of installing mixed plant in any new station on that account will be controlled by the size of the plant, its total first cost, and the interest and sinking fund charges imposed on same.

Of the several points that remain to be touched upon, Fig. 9 shows the steam-consumption curves of two types of exhaust turbines under varying back-pressure conditions. It will be noted that the output of the impulse type increases more than that of the reaction type when the absolute back pressure is reduced from 2 pounds to 1 pound per square inch. It will also be noted that if the condensing plant fails to give a good vacuum then the rated capacity of the set may not be obtainable and the fuel consumption will rise simultaneously.

Fig. 10 shows the steam consumption of different sizes of exhaust turbines and from that it will be readily understood how necessary it is to select a turbine that is not too large for the work to be performed.

In this connection it will be well to point out that the load on a turbine arranged as in Figs. 5 and 6 will reach a maximum only when steam flows from the winding and other engines.

On this account the average load may be deemed to lower the over-all efficiency of the system, but the over-all efficiency is much higher than that of a smaller set working in conjunction with steam accumulators, which latter have only an indifferent efficiency.

Fig. 2 shows the influence the condensing plant has on the satisfactory operation of a turbine.

It is a great mistake to think that any sort of a condensing plant will do for a turbine.

Of all the many points that must be observed in selecting and laying out a turbine plant, there is none of greater importance than the condensing plant. The introduction of the turbine has caused much attention and experiment to be devoted to condenser design and the necessary auxiliaries. Practically all the best surface condenser builders have embodied the contra-flow principle, which was introduced to the engineering world by D B Morison, of Richardson, Westgarth & Co., Ltd., England.

Closely associated with the condenser is the water-cooling plant for the cooling of the condenser-circulating water, and which it is necessary to have in all districts or localities where running water is not available.

A cooling plant of proper design and size may be able to turn out cooled water at 70 degrees, while one of insufficient size may

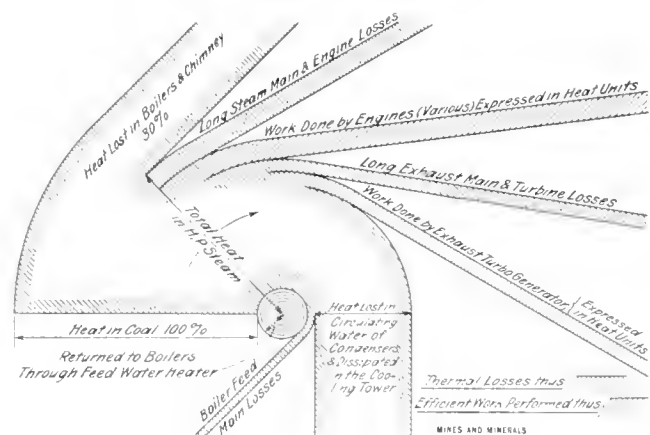

FIG. 8. SHOWING APPROXIMATE THERMAL EFFICIENCY OF A STEAM PLANT ARRANGED AS IN FIG. 6

be able only to give 80 degrees. With water at 70° F., a 750-kilo-watt exhaust turbine with a surface condenser will give a net output with 12,000 pounds of steam per hour, or about 12 per cent. more than can be obtained with the same quantity of water at 80 degrees, and with 24,000 pounds the output will be 9 per cent. greater.

These figures can be read from the curves shown in Fig. 2.

Jet condensers of various forms can be utilized in place of surface condensers, but where cooling towers are in circuit some types are open to objections, which are not to be found in surface types.

The quality of circulating water for the condensers is a very important factor in the maintaining of a good vacuum. It is suggested that the difficulty of maintaining the vacuum in surface condensers, where ordinary make-up water is obtained from town

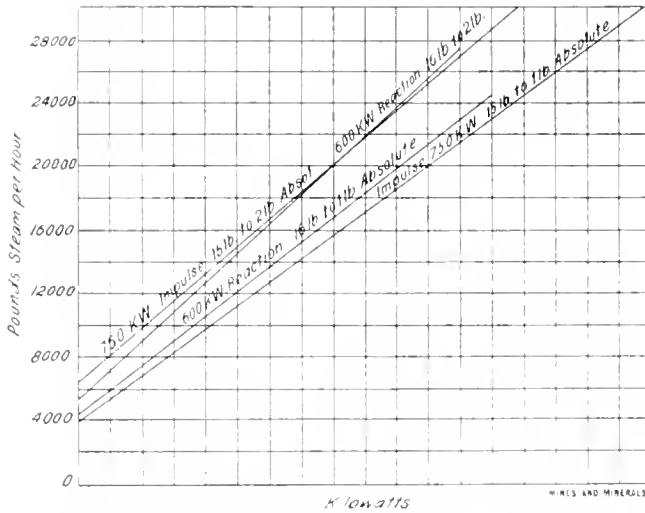

FIG. 9. EXHAUST STEAM CONSUMPTIONS OF IMPULSE AND REACTION MIXED PRESSURE TURBINES, WITH VARIOUS ABSOLUTE BACK PRESSURES

supplies, can be considerably reduced by using the water of condensation instead. With this arrangement no deposit of scale can coat the tubes, and consequently a better vacuum and higher turbine efficiency can be maintained.

This the writer considers will far outweigh any thermal loss due to the fact of the high temperature of the air-pump discharge not being utilized when the condensation water is so made use of.

If a water-softening plant is used, and the use of such is essential where bad water is the only kind that is available for the boilers or for the cooling tower make up, then the fact that the softening process requires temperatures of from 100° F. to 180° F. will make the question of thermal loss just referred to quite immaterial.

In conclusion the various general forms of exhaust turbines that may be applied to generate power from exhaust steam are as follows:

1. Plain exhaust or low-pressure turbines.
2. Semi-mixed pressure turbines.
3. Mixed-pressure turbines.

Plain exhaust pressure turbines are without any high-pressure blades, and if constant operation is required when no exhaust steam is available, then live steam must be admitted to the exhaust main by a reducing valve. Where ample low-pressure steam is available, and high-pressure steam is seldom required, this form of turbine will give the best results.

Mixed-pressure turbines are virtually high-pressure steam turbines, having an additional inlet and governor for the admission and regulation of exhaust- or low-pressure steam.

Semimixed-pressure turbines are similar to mixed-pressure, but fitted with an arrangement of high-pressure blading, which serves to reduce the churning losses that obtain in connection with the mixed-pressure turbine when the high-pressure blading is not in use and all power is being developed by the low-pressure blading.

The selection of one or other of these forms should be controlled by the amount and periods of supply of low- and high-pressure steam, respectively, in order that the best average efficiency may be obtained under all conditions.

Irrigation With Artesian Waters in Australia

Consul Henry D. Baker, of Hobart, Tasmania, in a recent number of the United States Consular Report, mentions a series of experiments carried out in the artesian area of New South Wales by Mr. R. S. Symmonds, agricultural chemist, to ascertain the effects of applying nitric acid to soils impregnated with carbonate of soda from artesian water. The results achieved have been astonishingly successful and seem to justify the hope that vast areas, where artesian water can be obtained by boring, but is ordinarily so alkaline as to injure the soil, can be made in the future capable of yielding large crops.

There is one serious difficulty in the way of applying the nitric-acid remedy to the soil on any large scale in Australia, and that is the high cost of nitric acid, which is now quoted in Sydney at about \$160 per ton. It is suggested, however, that it would be possible to manufacture nitric acid in large amounts from the atmosphere by burning atmospheric air in electric furnaces of tremendous heat, and Mr. Symmonds has proposed, as a means of getting practical results from the use of nitric acid, to utilize the power of the bore water, which frequently soars up hundreds of feet, for obtaining nitrogen from the air.

There are also large deposits of coal in some of the artesian districts which could be utilized for the same purpose. As the bore waters contain considerable lime, carbonate of soda, and other ingredients which, combined with nitrogen, make valuable fertilizers, there seems a possibility that, in connection with manufacture on a large scale of nitric acid for irrigation purposes, lime nitrogen and other nitrates might be produced for export.



Tin Mining in the Federated Malay States

A recent United States Consular Report states that the chief mineral mined in the Federated Malay States is tin ore, the working of which has been of comparatively recent date. Years ago the Siamese mined it to some extent, but it was not until the advent of the Chinese that the states came into prominence as a tin producing country. Until the installation of steam pumps in recent

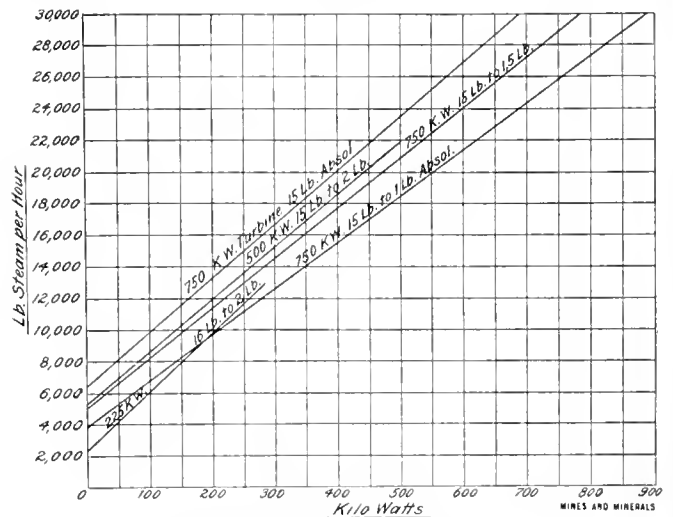

FIG. 10. RELATIVE EXHAUST STEAM CONSUMPTIONS OF DIFFERENT SIZES OF MIXED PRESSURE IMPULSE TURBINES

years, water was removed from the mines in buckets and by means of crude chain pumps operated by waterwheels. In certain deposits the old Chinese methods are still used. Tin is obtained from cassiterite by the reduction of this ore in reverberatory or in Chinese blast furnaces. At least nine-tenths of the ore is obtained from alluvial deposits. Nearly pure tin ore ranges in form from fine dust to lumps of several hundred pounds in weight, and is found in every kind of soil from the surface to depths of 250 feet.

Mining in the Tintic District, Utah

The Godiva-Sioux Zone. Peculiar Caves Filled With Ore. Methods of Mining and Milling

By Leroy Palmer

The Godiva-Sioux zone of the Tintic district embraces that portion locally known as the east side, beginning at the south end of the old North Star mine. It extends northeasterly to the Sioux Mountain then bends to the north until it reaches the north side of Godiva Mountain. The fractures in this zone range from due north, to N 35° E at the south end, to north to N 15° E in the central portion, and from north to N 30° W in the northern portion. All of the fractures are vertical with slight secondary fracturing and the ore bodies follow the fractures. At the south end the ore occurs in several short bodies, but through the central portion there is one continuous ore body that has been proven for 5,000 feet or more, while at the north end the ore is more irregular, being short and lense shaped and pitching south of west. In the central portion the ore bodies, in many cases at the contact of the Godiva limestone and the Humbug formation, depart from the fissures and make off into the bedding planes with a dip eastward of from 25 to 65 degrees.

Some of the ore-bearing fractures have faulted, showing that there were two periods of fracturing. This is especially exemplified at the Spy-Ajax fault, where the fractures on the opposite sides do not correspond, indicating that there has been faulting subsequent to that which occurred in a northerly and southerly direction. The Spy-Ajax fault has been traced to an extrusion of rhyolite, the earliest of the eruptive rocks, some distance away, but does not penetrate it, indicating that faulting occurred previous to the outpouring of the lava.

Most of the mines of the Godiva-Sioux zone are new in comparison with those of the Eureka and Mammoth zones and, consequently, have not reached the depth gained by the latter.

They are all in the oxidized zone and are not troubled by water, the Iron Blossom, No. 1, the deepest of those now working, being still dry at a depth of 1,900 feet. The ore-bearing formation is limestone, as in the other zones, but it is of a compact nature, as a rule, and, except in rare instances, does not call for such heavy timbering. Where bad ground has been encountered it is usually only in a small area, so that it is necessary to support it only while the ore is being extracted, after which the timbers are drawn and the ground caved.

A feature of this zone is the numerous caves found in the limestone, usually filled with rich ore. It was supposed that, in some way, these caves were the cause of the ore found in them, but a much more plausible theory is that the ore is the cause and not the result of the cave. The ore-bearing solutions ascending through the limestone decomposed large portions and deposited the ore in the form of a sulphide. Through the influence of other agencies, probably surface waters percolating through the formations, this ore was oxidized and consequently became porous, after which a movement of the earth's crust caused it to settle and contract, leaving it loose and with a space at the top, sometimes of sufficient size for a man to crawl through between the top of the ore and the roof of the cave. At present the active mines in this belt are the May Day, Uncle Sam, Colorado, Sioux Consolidated, and Iron Blossom, with Beck Tunnel and Yankee Consolidated engaged in development work.

The May Day mine lies at the northern end of the Godiva-Sioux zone, just south of the Godiva, the earliest worked of the

mines in this portion of the district, and which is now idle. The property includes 60 acres in the Godiva limestone and a mill site. Operation is through a shaft and a tunnel which taps it at a point 170 feet below the surface. The shaft is operating only one compartment, but is sunk with two 4 ft. \times 4 ft. 6 in. and a manway to the 800-foot level, from which point a 57-degree incline goes down 300 feet, giving a vertical distance of 250 feet. The tunnel, which is the haulageway, is driven 6 ft. \times 8 ft. through limestone and requires little timbering, as is the case with most of the drifts in this mine, but on the 500-foot and the lower levels a peculiar formation known locally as the "black dike" has been found. This is about 100 feet wide and consists of a black material which analyzes 30 per cent. each of sulphur, iron, and silica. It decomposes on exposure to the air and swells constantly in the drifts, making necessary the continual easing of the timbers. Water constantly seeps through it and this water is so impregnated with sulphuric acid that it has been found necessary to pipe it through wood to an open fissure which is not yet full after receiving it for many years.

The ore in the May Day is found in the north and south fissures that dip slightly toward the east. At present only such an amount as is necessary to supply two shifts at the mill is being taken out. This comes from the 500-foot level about 200 feet east of the black dike, where a raise was put up to reach an ore body that had been worked on the upper levels. This body is 38 feet wide and is being

worked upward for a distance of 100 feet by what might be termed a modification of the room-and-pillar method of coal mining, the difference being that the pillars are left horizontal to withstand the side pressure of the practically vertical walls. Mining is done by the overhand method. The pillars are cut out 20 feet square extending from wall to wall with a 20-foot space to the next pillar. The next set is staggered with the first, that is the pillar is left opposite the open space of the first set. All of the holes drilled in breaking the ore are uppers, and two men break down 10 tons a shift, using hammer-drill stopers with 35 per

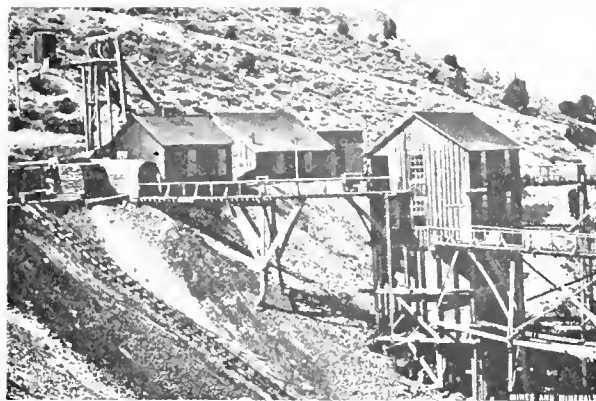

FIG. 1. IRON BLOSSOM HOIST

cent. dynamite. The ore falls from the sto to a raise in which is a 3' \times 3' chute to the 500-foot level, from which it is hoisted to the tunnel and trammed to the mill.

The drifts are made 5 ft. \times 7 ft. with rounds of 11 to 15 holes, the usual round being three rows of three each with one extra cut hole and one extra lifter. Single and double Ingersoll-Rand piston machines are used with 35- to 40-per-cent. dynamite, according to the nature of the ground, which usually requires the stronger explosive. A round will advance the drift from 3 to 4½ feet.

The surface equipment consists of two 40-horsepower Erie return-tubular boilers, an 8' \times 10' duplex hoist with 24' \times 36' drum and ¾-inch rope and 12' \times 12' \times 12' Stillwell-Bierce and Smith-Vaile straight-line compressor with a capacity of 130 cubic feet of free air per minute, working to 90 pounds.

The May Day is the only mine in the district operating a mill. It is situated on a hillside about 100 feet from the mouth of the tunnel at a point such that the ore can be delivered direct to the crusher floor. It is dumped to a 6-inch grizzly, the oversize of which goes to an 8' \times 12' Blake crusher and the undersize to a 2-inch grizzly whose oversize goes to the rolls and undersize to the first trommel. The crusher breaks to 2 inches and discharges to an elevator to a bin from which a shaking feeder discharges it to a set of 26' \times 15' rolls set to ¼ inch. The roll product goes to a ¾-inch-mesh conical trommel whose oversize is elevated back to the bin and the undersize sent to a ¼-inch-mesh conical trommel.

The oversize of the $\frac{1}{2}$ -inch trommel goes to three two-compartment Harz jigs and the undersize to a classifier whose spigot discharge feeds one similar jig. The coarse jigs make finished concentrate on the first compartment and middling on the second, which is tapped through the hutch and shoveled back to the head of the jig. The fine jigs make concentrate through both hutch. The coarse tailing passes over a screen to dewater it and discharges to a bin from which it is loaded to cars and trammed to the dump. The water from this tailing is used in a 5-foot Huntington mill which regrinds the middling product of the fine jig. The middling and the overflow of the classifier that feeds the fine jig go to a single-compartment classifier whose spigot product feeds a Wilfley table. The overflow of the classifier goes to two settling tanks, each of which feeds a table, and the overflow of the tanks is used as wash-water. The tables make only two products, concentrate and tailing. The tailing goes to three tanks in which it is settled and drawn through the spigot with only sufficient water to carry it out of the mill, going to an elevator that raises it to a point from which it will flow to the dump. The overflow of the tank goes to a centrifugal pump and is pumped back and reused. Water, as will be inferred, is scarce and is pumped from Homansville, 2 miles distant. The mill recovery is 83 per cent. on the lead and 50 per cent. on the silver.

South of the May Day mine is the Yankee Consolidated property, in which work is at present confined to the sinking of the



FIG. 2. MAY DAY MILL

main shaft. Next in the chain is the Uncle Sam mine, a fraction of 18 acres lying on a hillside between the Yankee and the Beck Tunnel claims. The mine is operated through a tunnel driven into the hill at comparatively shallow depth. The vein has been followed the length of the claim and seems to conform to the contour of the hill with a dip of 30 degrees to the east. It has been opened up as wide as 350 feet on the dip and shows thickness varying from 8 to 30 feet. About 20 per cent. of the entire amount of ore is a good shipping grade, which is found in chimneys and runs from 30 to 45 per cent. lead without any sorting. The remainder is a lower grade of shipping with a considerable quantity of good milling ore.

The tunnels and drifts correspond in size to those of the May Day and the work is carried on in a similar manner, the two mines being under the same management. The tunnel mentioned goes to a station at the upper end of an incline with a pitch of 67 degrees and a slope distance of 260 feet, equal to a vertical depth of 240 feet. The deposit is in the Goliva limestone, which is uniformly firm and simplifies the matter of timbering. Very little timber is required in the drifts and this incline and the one below it are timbered only about one-third of the way, for the remainder the line walls being unsupported and the skip track resting on ties set in hitches in the rock. Those portions of the drifts and inclines that require timbering have 8" x 8" sticks. The hoisting equipment at each incline consists of a 22-horsepower, General Electric, three-phase, variable-speed induction motor, wound for 440 volts

and geared to a hoist winding a 1-inch rope. Above the level, between the two inclines, the ore is chuted to an ore pocket from which it is loaded to a skip, hoisted through the upper incline, and trammed out of the tunnel, from which it is hauled in wagons to Summit, a station on the Denver & Rio Grande. Below this intermediate level the ore is lowered in the second incline and trammed out through the Beck Tunnel, which adjoins Uncle Sam on the south, and is shipped by the narrow-gauge Eureka Hill Railroad.

In this lower portion the vein is widest and appears more like a bedded deposit, and square setting has been found to be the most practical way of extracting it. Eight by eight-inch timbers are used, and framed with the posts butting, to sustain a pressure that is practically vertical, the stopes being carried to a width of from 30 to 40 feet in a single system of timbering. In the upper portion of the mine the deposit is not so thick and the hanging wall is firm, so that the only timbering used consists of round posts with headboards.

Stoping is done by single-hand drilling. The reason for this is that a great deal of the ore is a very pure galena, consequently soft and crumbly. The machine stopers make so much dust in this ore that the men working in it would get leaded in a short time if machines were used, so the slower method has been adopted as a protection to the miners.

Uncle Sam and its southerly neighbor, Beck Tunnel, recently offered a pleasing contrast to some of the mines of the Tintic district that have carried on bitter litigation covering a period of years. Uncle Sam served notice on the Beck Tunnel that it would go over its side lines into Beck ground and that it claimed the ore by right of apex. As soon as this move was made Beck Tunnel started suit for trespass and Uncle Sam filed counter claim for certain ore bodies in Beck Tunnel ground which is claimed apexed in Uncle Sam. Prospects were good for a stubborn contest which would probably take Uncle Sam out of the dividend class and bankrupt Beck Tunnel, which was then levying assessments, when the two warring factions got together and compromised the matter, Uncle Sam agreeing to cease following the ore body at a certain point beyond the Beck lines and receiving the right to use the Beck Tunnel for the transportation of its ores.

At present Beck Tunnel is engaged in developing the ore bodies near the Uncle Sam lines, so does not present any features of particular interest. The next active mine is the Colorado, which adjoins the Beck Tunnel on the south. The Colorado is opened to the 300-foot level by a two-compartment and manway shaft with 8" x 8" timbers. Drifts on this level connect the Beck Tunnel on the north and the Sioux Consolidated on the south. The mine was first opened on the 250-foot level, where a drift was sent out from the shaft to tap ore bodies that were known to exist in the Beck Tunnel and which it was expected to reach on this level of the Colorado.

This drift broke into an ore-filled cave and during the year that this cave was worked the company paid dividends of \$960,000 on a capital stock of \$200,000. The cave was 150 ft. x 60 ft. x 35 ft., and practically filled with ore so loose that most of it ran like sand. In the mining of this deposit very little powder was required, most of the work being done by pick and shovel, four men being required to load and run the ore that one pick man would loosen. The method of working was to put a raise to the hanging wall and take out the ore by slicing from the top down. While the walls were reasonably firm it was deemed advisable to timber, as a weakness might have started a caving of ground which would have entailed great loss of life and ruined the mine. Most of this timbering was in the form of regular square sets, although in the thinner portions of the vein posts or stulls of round timbers were used. Occasionally the operations encountered large horses of lime that had broken off from the hanging wall. These were supported by timbering carefully with round posts which have been left in and present an interesting sight, huge boulders on stilts in an immense stope. After the cave was worked out the timbers were shot out and the walls and roof allowed to come in.

The average dip is 20 degrees to the east. The ore zone is 60 degrees and there are 150 feet of ore. The system of tunneling used in this mine is similar to that used by the inclined system and the hanging system. It is not necessary to strike and post. The mine has a main drift and one main crosscut drift. The main drift is 100 feet long and the crosscut drift is 100 feet long. The workings are in the 100-foot drift and the crosscut drift.

The plant is built on the 100-foot drift. It has a 100-horsepower motor and a 100-horsepower generator. The Central plant supplies the power to the mine and also in the Iron Branch. The plant has a 100-horsepower motor and a 100-horsepower generator. The plant has a 100-horsepower motor and a 100-horsepower generator. The plant has a 100-horsepower motor and a 100-horsepower generator. The plant has a 100-horsepower motor and a 100-horsepower generator.

The main drift is 100 feet long and the crosscut drift is 100 feet long. The main drift is 100 feet long and the crosscut drift is 100 feet long. The main drift is 100 feet long and the crosscut drift is 100 feet long. The main drift is 100 feet long and the crosscut drift is 100 feet long.

The formation is a layer of... The dip is 20 to 30 degrees to the east. The ore zone was found to be... The square-set method is used... The usual angle braces from top to post... In general, the line is quite firm and the hanging rods are but little timbering... The sets are used and after that part has been worked... where the ground is hard that an attempt is made to recover... left to stay in the slope... the usual angle braces from top to post... ground the sets have been filled with large round timbers... in Fig. 4 so as to withstand any weight they may be called upon to bear... the shape of round timbers set perpendicular to the drift... made to recover these timbers... larger ropes large blocks of... These have been supported in the drift... of an... to recover these timbers they are left in.

Where the ground is hard or moderately hard... work machine... mined by... as to make a hole that will hold a charge of... contains... break up to... level, in the square-set ropes the timbers being run down... the sets and hunted out of the shaft.

The main drift is 100 feet long and the crosscut drift is 100 feet long. The main drift is 100 feet long and the crosscut drift is 100 feet long. The main drift is 100 feet long and the crosscut drift is 100 feet long.

The plant is built on the 100-foot drift. It has a 100-horsepower motor and a 100-horsepower generator. The Central plant supplies the power to the mine and also in the Iron Branch.

The main drift is 100 feet long and the crosscut drift is 100 feet long. The main drift is 100 feet long and the crosscut drift is 100 feet long. The main drift is 100 feet long and the crosscut drift is 100 feet long.

The formation is a layer of... The dip is 20 to 30 degrees to the east. The ore zone was found to be... The square-set method is used... The usual angle braces from top to post... In general, the line is quite firm and the hanging rods are but little timbering... The sets are used and after that part has been worked... where the ground is hard that an attempt is made to recover... left to stay in the slope... the usual angle braces from top to post... ground the sets have been filled with large round timbers... in Fig. 4 so as to withstand any weight they may be called upon to bear... the shape of round timbers set perpendicular to the drift... made to recover these timbers... larger ropes large blocks of... These have been supported in the drift... of an... to recover these timbers they are left in.



Fig. 4. View of mine shaft.

The main drift is 100 feet long and the crosscut drift is 100 feet long. The main drift is 100 feet long and the crosscut drift is 100 feet long. The main drift is 100 feet long and the crosscut drift is 100 feet long.

The plant is built on the 100-foot drift. It has a 100-horsepower motor and a 100-horsepower generator. The Central plant supplies the power to the mine and also in the Iron Branch.

The main drift is 100 feet long and the crosscut drift is 100 feet long. The main drift is 100 feet long and the crosscut drift is 100 feet long. The main drift is 100 feet long and the crosscut drift is 100 feet long.

Where the ground is hard or moderately hard... work machine... mined by... as to make a hole that will hold a charge of... contains... break up to... level, in the square-set ropes the timbers being run down... the sets and hunted out of the shaft.

not equal that of the Eureka zone, but, conditions being considered, compares very favorably.

Acknowledgment to all who assisted in collecting the notes for this article would be impossible. All of the companies visited gave ready access to all portions of the mines and information on all points on which it was sought. The writer is indebted to various officials and employes of the different mines which appear in the above descriptions.

采 采

Ore Mining Notes

Closing Colorado City Reduction Plant.—It is announced that, owing to a shortage of ore from the Cripple Creek district, the Standard plant of the United States Reduction and Refining Co., Colorado City, Colo., will close down for an indefinite period after nearly fifteen years of successful operation. No ore will be received at the mill after December 1, although it is expected actual operations will be continued until about the first of the year to clean up stocks on hand and in transit. All ore contracts of the United States Reduction and Refining Co. will be carried out at the agreed prices by the Golden Cycle mill at the same point. Mr. J. D. Hawkins, president and general manager of the United States Reduction and Refining Co., in his letter to ore shippers says: "When conditions warrant the reopening of our plants, we will promptly advise you, etc.," which indicates that the suspension is but temporary. Some 175 men will be laid off and about 13,000 tons of ore monthly turned over to the Golden Cycle mill by reason of this shut-down.—G. F. D.

Rescue Apparatus at Metal Mines.—The Portland Gold Mining Co., Victor, Colo., has recently installed five sets of rescue apparatus at its mines, being the first metal mining company in the state to take this step. United States Bureau of Mines Rescue Car No. 2 will be at Victor during the last week in December and probably the first week in January to train the men in the use of the helmets.—G. F. D.

The Electra Oil Field, Texas.—Within a few weeks the oil field, in Wichita County, has jumped from a hope to the largest oil producer in Texas. The average production from 28 wells is about 300 barrels daily which is said to be larger than that of the Caddo field in Louisiana. Information concerning this new oil field can be had from Wm. B. Phillips, University of Texas, Austin, Texas, who is Director of the Bureau of Economic Geology and Technology.—W. B. P.

Copper in Texas.—Since the discovery of oil in Archer County, people are again beginning to notice the copper deposits in Archer and in Wichita counties just south of Wichita in the middle northern part of Texas. W. H. Streeruwitz, of Houston, examined this territory in 1883 and 1884. He stated that copper carbonate and pseudomorphous copper glance is found loosely distributed in bluish gray clay. He considered that the ore which was in Permian formation was washed down from the Wichita range. Large masses weighing as much as 2 tons have been found but no ore has been exposed. W. B. Phillips of Texas

Bureau of Economic Geology, says: "Since November 1, we have had letters of inquiry concerning the copper ore that occurs within easy reach of these oil and gas fields. As early as 1874 more than 10,000 pounds of high-grade copper ore was sent from this district to the Schuylkill Copper Works, and the different lots averaged nearly 60 per cent. of copper (Texas Geological Survey, Second Annual Report, 1890, p. 450). Some of the ore from Archer County was used for making gun caps for the Confederate Army.

"In the Report just quoted the statement is made that several hundred tons of better grade ore was mined and shipped to Philadelphia and Baltimore somewhere between 1865 and 1874, the distance to a railroad, in some cases, being 250 miles.

"Gen. Geo. B. McClellan, who died in 1885, was with Captain Marcy in the Red River Expedition in 1852 and had his attention called to these ores at that time. In 1882 to 1884 he organized a company for exploiting and working them, but, owing to a misapprehension as to their nature and the almost total lack of transportation facilities, the enterprise did not succeed.

"With the coming in of cheap fuel and the opening of the region by several lines of railroad, traversing the ore regions, it would appear that some, at least, of these rich copper deposits could be utilized."

Other sporadic attempts have been made to work these deposits, the difficulty however has been in their concentration.

Uranium from Gilpin County, Colo.—A mass of pitchblende or uraninite, weighing 240 pounds, it is reported, was recently taken from one of the uranium producers on Quartz Hill in Gilpin County. This pitch-blende surpasses in radioactivity the pitch-blende produced in Austria, but has not yet been developed in large bodies. Small but rich pockets are occasionally encountered in the devel-

opment of the other ores for which the mines are worked. Similar ore, it is reported, has been shipped in the past from the Jo Reynolds mine in Clear Creek County. Shipments valued at \$120 a ton are reported from the Corydon, a mine that has been idle most of the time for twenty years. The property is owned by Senator Henry N. Teller and associates, of Denver. Shipments reported from the Pittsburg, in Russell Gulch, ran \$325 a ton for the first-class ore, and \$225 a ton for the second class. The ore was taken from the 800-foot level, and preparations have been made to follow it to greater depths.—C. B. I.

Alaska Treadwell Mine.—At the Treadwell mines on Douglas Island the new central hoisting plant is well under way, most of the concrete work for the foundations and ore bins having been completed. This will have a capacity of 5,000 tons of ore per day of 24 hours from a depth of 3,000 feet, and is probably the largest individual hoisting unit in the world. This hoist will be used exclusively for hoisting ore, but double-decked man cages will be swung on guides so the ore skips can be immediately replaced and the man cages used if an accident should interfere with the working of the other hoists.—P. S. S.

Gypsum in Alaska.—The gypsum mine of the Pacific Coast Gypsum Co. in the Sitka district is shipping between 2,000 and 3,000 tons per month of high-grade gypsum



FIG. 4. HORSE OF ROCK SUPPORTED ON POSTS, FILLED SETS IN BACKGROUND

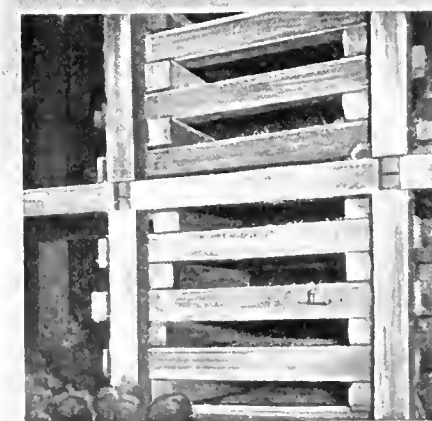

FIG. 5. CRIBBING IN STOPE, SIOUX CONSOLIDATED MINE

to the company's plant at Tacoma, Wash., where it is used largely in the manufacture of wall plaster. The lateral workings of the company have extended over an area of approximately 200 by 500 feet with a depth of 160 feet, though the limits of the ore body have not been determined. Hand boring machines, similar to those used in coal mining, are used in drilling the holes, and the gypsum is broken into a full stope, only enough being removed to give the men room to work until the stope is completed.—P. S. S.

The Mineral Production of North Carolina.—There is given in the table below the production of each mineral produced in North Carolina during 1908, 1909, and 1910; where there were less than three producers the mineral is included under "Miscellaneous."

Mineral	1908	1909	1910
Gold	\$97,495	\$43,075	\$68,586
Silver	668	324	4,888
Copper	2,560	29,186	17,845
Iron	76,877	107,913	114,237
Garnet	4,052	9,188	7,981
Millstone			
Mica (Sheet)	114,540	122,246	193,223
Mica (Scrap)	13,330	26,178	37,237
Precious stones	570	479	790
Monazite	37,224	46,928	16,104
Zircon		250	
Talc and Pyrophyllite	31,443	77,983	69,805
Mineral waters	27,163	20,558	21,389
Stone	824,927	850,807	920,027
Sand and gravel	2,070	13,358	13,406
Clay products	944,317	1,302,611	1,223,794
Miscellaneous*	109,880	133,642	145,314
Totals	\$2,307,116	\$2,783,826	\$2,848,446

*Includes barytes, sand-lime brick, and kaolin productions.

—J. H. P.

Chichagoff Mine, Sitka, Alaska.—The Chichagoff Mining Co. is operating the Golden Gate mine as well as its own, the latter being held under lease and bond. Both properties are situated on a vein of high-grade gold ore and considerable prospecting is being done at other points in an endeavor to pick up the same lead. Two discoveries of rich float on the islands of this district have caused small stampedes recently but nothing of proved value has been found.—P. S. S.

Ketchikan District, Alaska.—In the Ketchikan district there will be considerable winter work, the Rush & Brown, It, Mt. Andrew, and Sulzer mines continuing in the shipping list with a number of other properties prospecting and doing the assessment work.—P. S. S.

Federal Mining and Smelting Co., which has productive mines at Mullan, Wardner, and Mace, Idaho, has declared its regular quarterly dividend of 1½ cents, or \$210,000, on \$12,000,000 of its preferred stock outstanding. This brings the total for the year to \$840,000 and \$6,851,250 to date. The last dividend paid on common stock of the Federal company was in January, 1909. The total dividends on this stock aggregate \$2,708,750. The grand total of dividend disbursements of the company is \$9,560,000.—A. W.

No. 1 Mine, Ainsworth, B. C.—A silver-lead property at Ainsworth, B. C., has been taken over on a lease and bond by the Consolidated Mining and Smelting Co., of Trail, B. C. It has been worked at times during the last 27 years by numerous owners and bondees, none of whom could uncover the large bodies of ore known to exist in the mine, and it remained for a Nova Scotia syndicate to make a shipper out of the property, but owing to lack of funds they made little money. However, the recent leasers did well.—A. W.

Sunset Mine, in the Sunset Peak district of the Coeur d'Alenes, will be opened upon an extensive scale early next spring by William A. Clark, of Butte. The property has been idle nearly 20 years. It is the premier mine of the district. It is announced by Mr. Clark that a large force will be put to work when operations begin.—A. W.

Tungsten Consolidated Cos.—The owners of the tungsten deposits located on Blue Grouse Mountain, six miles northeast of Loon Lake, Wash., have ordered a concentrator mill to be erected at a point

800 feet below the level of the mine, and to be connected with it by means of a gravity tram. A 40-horsepower boiler, air compressor, and hoist have already been installed upon the property. Twenty men are at work opening stopes and drifts and taking out ore.—A. W.

Lake Iron Shipments.—Iron ore shipments during the month totaled 4,670,875 long tons, of which almost 70 per cent. proceeded from Duluth-Superior and Two Harbors. The shipments for the 10 months of the present season totaled 28,777,693 long tons, compared with 39,012,571 and 35,594,583 long tons shipped during the 10 months of 1910 and 1909, respectively. Of the total iron ore receipts for the season, 23,016,219 long tons, or 82 per cent., are credited to Lake Erie ports, and 5,131,618 long tons to Lake Michigan ports. A considerable decline in iron ore receipts is shown for all the important ports with the exception of Conneaut, which reports an increase of half a million tons, and Lorain, the season receipts of which closely approximate those of a year ago.—D. C.

Potash in United States.—Potash deposits exist somewhere in Utah in a form which could be made available for commerce. Feldspar is found in many localities, but to extract potash costs more than it is worth. Professor Hart, of Lafayette College, has succeeded in performing the operation, but not as a commercial proposition although he saved by-products, among them potash alum.

Those desiring full descriptions of feldspar and pegmatite deposits should write to the United States Geological Survey, Washington, D. C., for Bulletin No. 420.—E. B. W.

Maps of the Lake Superior Region.—A small number of extra copies of the geologic maps of the iron and copper districts of Lake Superior district have been printed for field use. These maps may be obtained at the prices indicated below from the Director of the United States Geological Survey, Washington, D. C.

	Price in Cents
Lake Superior region (Pl. 1)	25
Vermilion district, Minnesota (Pl. 6)	20
Mesabi district, Minnesota (Pl. 8)	25
Pigeon Point, Minnesota (Pl. 12)	5
Animikie district (Pl. 13)	1
Central Minnesota, including Cuyuna district (Pl. 14)	1
Penokee-Gogebie district, Michigan and Wisconsin (Pl. 16)	20
Marquette district, Michigan (Pl. 17)	20
Dead River area, Michigan (Pl. 20)	5
Perch Lake district, Michigan (Pl. 21)	5
Crystal Falls district, Michigan (Pl. 22)	10
Calumet district, Michigan (Pl. 23)	5
Iron River district, Michigan (Pl. 24)	10
Florence district, Wisconsin (Pl. 25)	5
Menominee district, Michigan (Pl. 26)	10
Keweenaw Point, Michigan (Pl. 28)	5

A discount of 40 per cent. will be made on all orders for maps amounting to \$5 or more at the prices given above, or these 16 maps, if ordered in one set, can be obtained for \$1.

Pebble Gathering in Normandy.—A recent United States consular report states that the pebble industry is making rapid progress and is assuming considerable importance in upper Normandy. The cliffs of the Caux region, undermined by subterranean springs and by the waves of the English Channel, slip, fall, and break. They are formed of a calcareous mass containing flints. These flints fall to the bottom of the sea, where they become flat and take an egg shape. Their color is blue, spotted with brown, yellow, or red stripes. They are used to manufacture concrete stone and earthenware, and their dust is even employed to make paint and rice-powder imitation. Over 120,000 tons of pebbles are annually picked up on the Normandy beaches. Most of them are sent abroad. Those employed in gathering these pebbles earn 34 cents per cubic meter (35.32 cubic feet).

Fullers' Earth in Texas.—Wm. B. Phillips, Director of the Bureau of Economic Geology and Technology, Texas, says:

"Fullers' earth of excellent quality has been found in several counties, Ellis, Burleson, Shelby, Smith, Fayette and Washington. The best known deposits are in Burleson county, near Somerville, in Washington county, near Burton, and in Fayette county, near O'Quinn and Muldoon. So far as known, at present, the largest deposits are in Fayette County and more is being done there for their development than elsewhere in the state.

"During 1910 the total production of fullers' earth in the United States was 32,822 tons, valued at \$293,709, or \$8.95 a ton. This production was distributed as follows:

Arkansas	2,563
California and Colorado	568
Florida	18,832
Georgia, Massachusetts, and South Carolina	9,995
Texas	864

"The value of the Texas product was \$8,582. Some of these earths are adapted for certain purposes and others for other purposes. For instance, the English earths seem to be better suited for refining vegetable oils and animal fats, while the American earths find their chief use in refining mineral oils. Chemical analyses are important, of course, but they are by no means as important as actual refining tests, conducted by experienced men."

Oil in Montezuma County, Colorado.—Oil sands at a depth of 150 feet are reported in the Big Four well which is now going down in the new field of southwestern Colorado. The drillers expect to encounter the main oil bearing strata at 1,200 to 1,500 feet.—C. B. I.

Saving San Juan Zinc.—Silverton is to have a reduction plant that will put profit into the zinc of the mixed sulphide ores. Arrangements for the construction of the mill have been completed. The Huff electrostatic separator will be used. This machine has been used with the most satisfactory results at the mills of the American Zinc Ore Separating Co. in Wisconsin, Utah, and elsewhere, and takes a readily marketable zinc concentrate out of San Juan ore that would otherwise have to pay a penalty on its zinc content when shipped to lead smelters.—C. B. I.

Unwatering Leadville Mines. The plans for unwatering the lower levels of the mines on Carbonate and Fryer hills have taken definite shape by the incorporation of the Leadville Mines Pumping Co. The work will begin at once. The directors of the company are Charles B. Dickinson, president of the Williams Lumber Co. of Leadville; J. B. McDonald, manager of the New Monarch Mining Co.; J. Clarence Hersey, a mining man; John Harvey, merchant and mine owner; George Argall, general manager of Iron Silver Mining Co.; Jesse F. McDonald, ex-governor of Colorado; L. P. Hammond, manager sales department of Central Colorado Power Co.—C. B. I.

Gold in the Wanakah Caves.—While examining a surface opening on the Ironclad claim of the Wanakah Co., Ouray, Colo., recently the manager and the superintendent of the company accidentally broke through the side of the cut into an open space. Further investigation showed it to be a cave with a floor of loose honeycomb quartz carrying high values in gold. This cave is similar to one opened on Wanakah ground in August, 1910, and from the latter 250 tons of rich ore was shipped. Similar caves have been the source of a large production on the American Nettle, a neighboring mine. The bulk of the production from Wanakah, however, comes from great deposits of low-grade pyrite ore.—C. B. I.

Alaska Perseverance Mine.—The final clean-up of the season of the Alaska Perseverance mine in the Juneau district is just completed, and the 100-stamp mill of the company at the head of Silver Bay basin has been shut down for the winter owing to the shortage of water during the cold weather, and the plates have been sent

to Seattle to be cleaned and replated. An 11,000-foot tunnel was started some time ago from the shore of Gastineau channel just opposite the Treadwell mines that will tap the Perseverance ore body several hundred feet lower than the present workings and open reserves for the new mill which the company is planning to build on the channel. When this tunnel is completed it is expected that the company will set a record for cheap working costs, as under the present unfavorable conditions the ore has been mined and milled for less than 80 cents per ton. The new mill will contain from 200 to 500 stamps. The ore body which is a sheared zone of slate containing numerous quartz stringers varies in width from 50 to 100 feet.—P. S. S.

乘 乘

Catalogs Received

VULCANITE PORTLAND CEMENT Co., New York, N. Y., Pamphlet No. 6, Selection and Proportion of Aggregates for Concrete, 31 pages.

ALLIS-CHALMERS Co., Milwaukee, Wis., Bulletin No. 1800, The Richards-Janney Classifier, 24 pages.

BUFFALO FORGE Co., Buffalo, N. Y., Catalog No. 199, Conoidal Fans, 46 pages.

ELECTRIC SERVICE SUPPLIES Co., Philadelphia, Pa., Mine Telephones, Signaling Apparatus, 19 pages.

GENERAL ELECTRIC Co., Schenectady, N. Y., Bulletin No. 4860, Generators for Electrolytic Work, 9 pages; Bulletin No. 4886, Electricity in Coal Mines, 60 pages.

GOULDS MFG. Co., Seneca Falls N. Y., Goulds Air Pressure and Vacuum Pumps, 16 pages; Bulletin No. 101, Triplex Plunger Pumps, 12 pages; Bulletin No. 103, Vertical, Single-Acting Triplex Plunger Pumps, 20 pages; Bulletin No. 104, Double-Acting Triplex Piston Pumps, 12 pages.

THE HESS FLUME Co., Denver, Colo., The Hess Galvanized Toncan Metal Flumes, 16 pages.

TRENTON IRON Co., Trenton, N. J., Wire Rope and the Elements of Its Uses, 80 pages.

INGERSOLL-RAND Co., 11 Broadway, New York, N. Y., "Little Giant" Rock Drills, 16 pages.

JEFFREY MFG. Co., Columbus, Ohio, Bulletin No. 41, Jeffrey Single Roll Coal Crusher, 8 pages.

H. W. JOHNS-MANVILLE Co., New York, N. Y., Blue Book, J-M Sea Rings, 16 pages.

JOHNSON & JOHNSON, New Brunswick, N. J., Circular No. 110, First Aid to the Injured, First Aid Outfits, 8 pages.

KEUFFEL & ESSER Co., New York, N. Y., Mathematical and Drawing Instruments, 8 pages.

PENNSYLVANIA CRUSHER Co., Philadelphia, Pa., Pennsylvania Crushers and Coal Cleaners, 16 pages.

STREETER-AMET WEIGHING and RECORDING Co., Chicago, Ill., Bulletin No. 2, Descriptive Circular of Automatic Weight Recorders.

TAYLOR IRON AND STEEL Co., High Bridge, N. J., Bulletin No. 100-B, Tisco Manganese Steel Gears and Pinions, 28 pages; Bulletin No. 113, Tisco Manganese Steel Chains, Sprockets and Spiral Conveyers, 20 pages.

THE GOULDS MANUFACTURING Co., Seneca Falls, N. Y., Bulletin No. 106, Vacuum and Stuff Pumps, 16 pages.

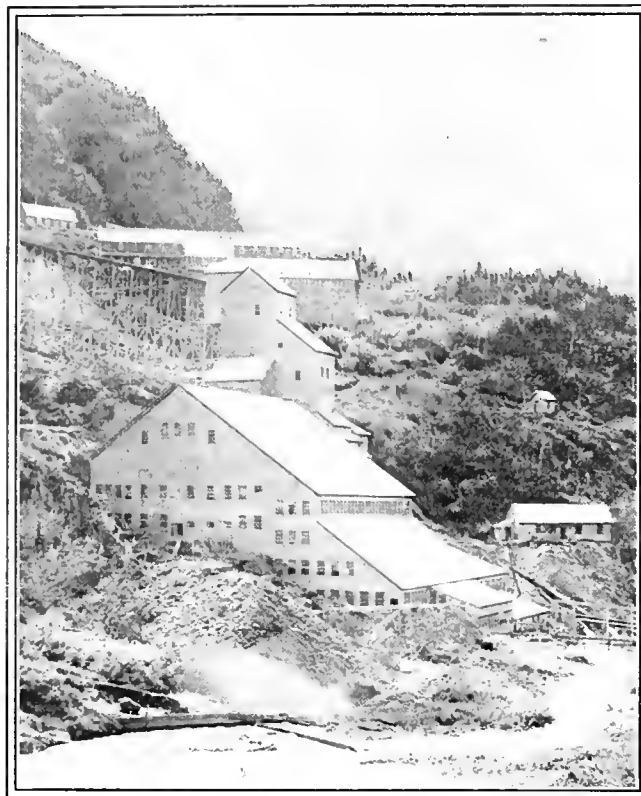

ALASKA PERSEVERANCE MILL

Treatment of Broken Hill Ores

A Description of Blast Furnace Operations as Conducted at the Port Pirie Smelting Works

By Wm. Poole

The following is an abstract from a paper presented before the Sydney University Engineering Society by William Poole, B. E., Director Charters Towers School of Mines:

The Port Pirie smelting works treats ore about as follows:

1. A mixed charge of concentrate, limestone, iron ore, and silicious ore (or if the latter is not to be had sand is substituted) is partially desulphurized in a roasting furnace.

2. Some of this roasted mixture is charged hot into converting pots, and a cooled wetted quantity of the same mixture is charged above it, and both blown with compressed air from underneath. This pot-sintered and desulphurized product is dumped on the floor, broken, and sent to the blast-furnace ore bins.

3. Sintered mixture from 2; sintered slime from concentrating mill, or fume products sintered; raw concentrate, iron ore, and limestone are charged into the blast furnace, furnishing slag and base bullion.

4. Flue products from the Huntington-Heberlein converting pots 2, from the blast furnace, and from the bag house are briquetted and sent to the Huntington-Heberlein converting pots and sintered previous to being charged in the furnace.

Blast Furnace Operations.—As originally constituted at Port Pirie there were 11 furnaces 212 in. \times 62 in., and two furnaces 120 in. \times 60 in. The height from the tapping floor to the feed-floor was 20 feet 6 inches. The down-take flues took off from the sides of the furnaces 6 feet below the feed-floor. The depth of the charge was about 11 feet. Later on the feed-floor was raised 4 feet, increasing the depth of the charge 4 feet, which enabled a higher blast to be used and greater capacity and closer recovery of products were obtained. The feed-floor immediately surrounding each furnace was of cast-iron plates supported on wrought-iron girders, an oblong feed-hole being left over the center of the furnace. More recently the down-take flue was replaced by a plate-iron hood 4 ft. \times 8 ft. over the furnaces, the lower end being slightly tapered and projecting 3 feet into the body of the furnace and charge.

This comparatively inexpensive alteration increased the height of the charge by another 3 feet, measured to the bottom of the flue, and 6 feet if to the floor, and has enabled still greater recovery of metals to be made, viz., the recovery now being: Lead*, 95 per cent.; silver, 98 per cent.; and at the same time decreasing the wall accretions.

The 212" \times 62" furnaces had 10 tuyeres on each side, the 120" \times 60", six tuyeres on each side and one at the end. The side tuyeres projected 9 inches into the furnaces, but it was long known that it made little difference if the ends of the tuyeres were burnt off, though they were considered useful in holding up the charge. The pro-

jecting tuyeres have now been generally discarded, the end being flush with the jackets. There are now 11 tuyeres on each side instead of 10, the end tuyeres being closer into the corners than formerly. Blast furnaces for lead smelting in Australia are usually considerably wider than those favored in the United States. The penetration of the blast is very efficient in these wide furnaces.

Blast-furnace practice in America has reached a position of exceedingly high efficiency if it is superior to that at Port Pirie and Cockle Creek, and we have good reasons to think it has not surpassed them, even if it is their equal.

In the matter of blast penetration, an experimental furnace, built at Port Pirie to the ideas of the Huntington-Heberlein representatives, is of considerable interest. It was circular in shape, 7 feet 4 inches in diameter at the tuyeres, and had vertical cast-iron water-jackets 2 feet 10 inches high, surmounted by a vertical ring of brickwork 9 inches thick by 14 inches high, to connect the jackets to the brick shaft, which was 16 feet high and increased in diameter to 11 feet 4 inches at the feed-floor level. The crucible pan was 10 feet 6 inches diameter by 4 feet 6 inches high, and the crucible was 2 feet deep below the jackets. The original arrangement of tuyeres was unusual—viz., seven tuyeres, 1-inch diameter and 6 inches above the bottoms of the jackets, and eight tuyeres, 1.5-inch diameter, 14 inches above the bottoms of the jackets. The penetration of the blast was effective, but the capacity was smaller than a 120" \times 60" furnace. The small tuyeres were replaced by 3-inch diameter tuyeres 9 inches above the bottoms of the jackets, giving an increased capacity. The recovery of metals was higher than the rectangular furnaces on the same charge, this no doubt being due to the large increase of area—viz., 125 per cent. between tuyere level and flue level, as against only 5 per cent. in the rectangular furnaces. Owing to the shortness of the jackets, considerable trouble was experienced, due to the burning out of the narrow ring of brickwork connecting the jackets to the main shaft. Trouble was also sometimes experienced owing to the charge slipping down into the crucible at the commencement of the campaign. The experiment showed that the furnace was readily workable with very high recovery, even though the tonnage was moderate. A properly designed furnace of this type—viz., with boshed jackets of greater height, and perhaps projecting tuyeres to hold the charge when blown in—would be exceedingly valuable for smelting ore rich in gold and silver, and volatile constituents, such as antimony, etc.

The Port Pirie works are built on reclaimed salt swamp land alongside the Port Pirie River. This is a good example where all the departments—viz., roasters, sintering plant, blast furnaces, refinery, and power plant—are all built on the same level. The Cockle Creek works are also so built, whereas the now abandoned Dapto works are on a series of steps. The one-level system of laying out large works has the great advantage of compactness, and the more ready access from one department to the other. The raw concentrates and sintered slime are shunted up an inclined embankment and trestle to the smelter feed-floor, and there unloaded from the railway trucks—the raw concentrate into supply bins for the

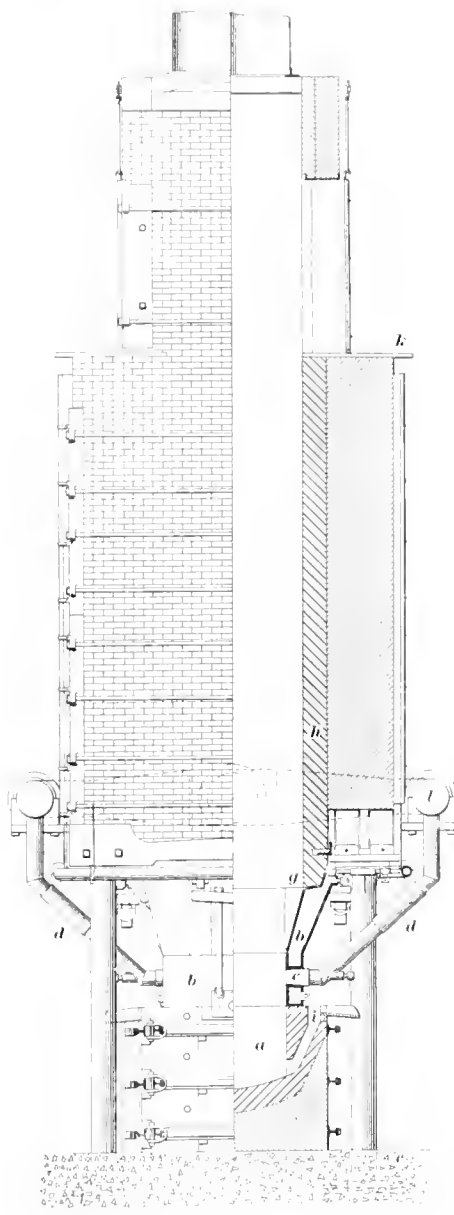

FIG. 1. LEAD SMELTING FURNACE

* Delprat, Trans. Aust. I. M. E., Vol. XII, page 19.

roasters, and the sintered slime direct to the furnaces—any excess being unloaded into large bins on the ground floor. Sintered concentrate, limestone, ironstone, and old slag are hoisted and tipped into bins above the feed-floor by aerial-hoist conveyers (locally termed "flying foxes"). Coke is also similarly hoisted on to a platform. The cost of hoisting is very low, and is much more than balanced by the reduced cost of handling the material on the feed-floor, owing to its great accessibility and convenience in running the material from chutes into the charge barrows.

Each charge totals about 2.5 tons. The charge barrows, Fig. 2, have a pair of high wheels, and hold about 500 to 800 pounds of ore or flux. The ore, flux, and returning slag are tipped on to the feed-plates, and shoveled into the furnace. They are brought in a regular order, so arranged that when fed in they are thoroughly mixed. The coke is, however, fed as a separate layer between each charge, this method having been found to give better results than when mixed through the charge. In order to preserve the layer feeding of coke on the large furnaces, the complete round of feeding consists of two charges, but with the full complement of coke fed as a single layer.

Fine material of any kind, except when in small proportion, quickly reduced the capacity of a furnace. Fine limestone had the most paralyzing effect.

The quantity of coke in a charge appreciably affects the cleanliness of the slags. A certain percentage of coke may effectively

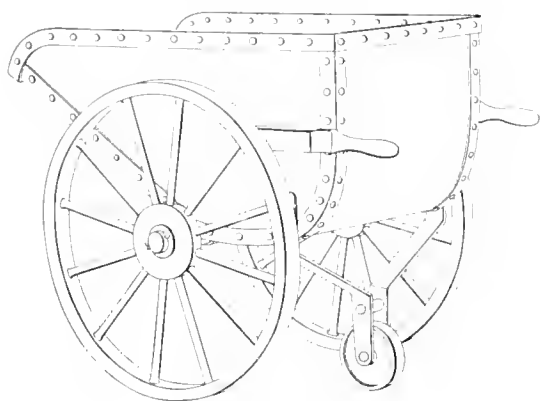

FIG. 2. FEED BARROW

melt the charge, but produce a "dirty" slag—i. e., one containing too much metal—whereas a higher percentage of coke may have the effect of cleaning it, as shown by the following example—the average obtained by running several furnaces for several weeks on the same charge, but with varying percentages of coke: With 12.5 per cent. of coke, the slags contained 2.5 per cent. lead; with 14 per cent. coke the slags contained 2 per cent. lead; with 16 per cent. coke the slags contained 1.2 per cent. lead.

The slag is drawn off at both ends, and if the furnace is working well may be kept continuously running, the slag being trapped by a breast separator. Clean slag is run out into large bowls, two of which are carried on a four-wheeled truck, the pair of bowls holding about 1.6 tons of slag. The pairs of slag pots are hauled by horses to the dump and easily tipped, as they are pivoted at about the center of gravity of the full pot. Foul slag is wheeled out into the yard in hand pots, and afterwards fed as return slag to the furnaces. The large furnaces have two lead wells, both on the same side. The bullion is run out through a movable spout into molds on a movable truck. The bars, 26 to the ton, are sampled, weighed, and sent to the refinery. The sampling is done as follows: A small piece about the size of a large pea is picked out of both the top and bottom surfaces of each bar, the position of sample working diagonally across five bars placed together. This method of sampling is very quickly performed, and is of sufficient accuracy for interdepartmental records. A day's sampling is melted down, well stirred, and a dip sample taken for the general sample of all furnaces on the same charge. Each furnace also has a special

dip sample taken each 12 hours from the lead well. These are assayed separately, to check the working of each furnace. Lead scraps and tapping-floor sweepings are returned once a shift to their respective furnaces.

Runaways of lead occasionally take place at the most carefully managed furnaces. It is remarkable how few men take

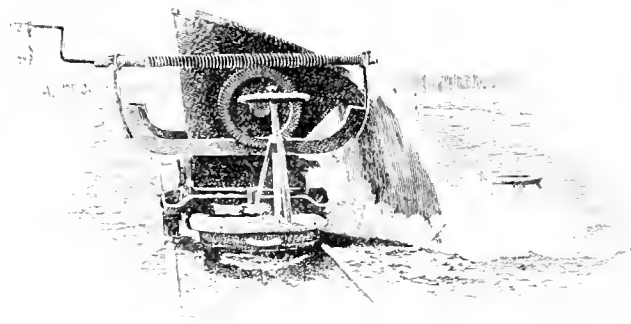

FIG. 3. SLAG POT

advantage of a fairly well known property of lead—viz., that, for a considerable range of temperature below point of solidification, lead is brittle, and can be broken by bars almost as readily as oat cakes, the fracture of which it closely resembles at that stage. If the lead is broken by bars as it solidifies, it can be readily hooked out of the way, and the mess cleaned up in a surprisingly short time. If it is allowed to get cold, it usually takes hours to laboriously cut it up with hammer and chisel.

The blast for the furnace is supplied by large Green blowers, at a pressure of about 30 to 35 ounces. These blowers are being supplemented by three turbo blowers.

The circulating water for the furnace jacket is salt water which has passed through the surface condensers in the power plant.

The flue dust obtained from the roaster, converter, and blast furnace flues is wetted down and fed into the sintering pots. Bag-house experiments for condensing fume have recently been undertaken in connection with the blast-furnace flues. The results are reported to be so satisfactory that an installation will probably be built to treat the whole of the gases now passing up the stack.

An interesting experiment was made to test the difficulties of smelting sintered slime without other ore or sintered concentrate. Ironstone and limestone were added to give a slag approximating to that normally obtained. The percentage of zinc was, however, considerably higher. The result was successful, except

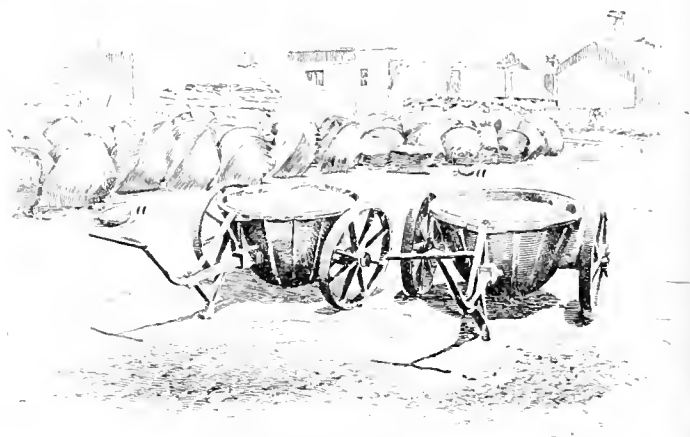

FIG. 4. HAND SLAG POT

in the essential item of recovery of metals. It was found that there were no furnace difficulties in merely smelting the material—the furnace ran considerably faster than usual, giving a hot and very liquid slag. This high temperature was undoubtedly due to the unusually large amount of uncombined siliceous matter forcing a much larger amount of the charge to reach a higher tem-

perature before fusing, and thus raising the average temperature of the slag. In an ordinary charge of Huntington-Heberlein material, much of it, including the returned slag, has already been more or less fused to silicates, and therefore a proportion of the charge melts and runs down as soon as the temperature in the blast furnace is sufficient, without reaching to the temperature of the for-

12 per cent.; *ZnO*, zinc oxide, 13 per cent.; *Al₂O₃*, alumina, 6 per cent.; *S*, sulphur, 3 per cent.; *Pb*, lead, 15 per cent.

The above slag is similar to former slags, except that the *CaO* has been decreased by about 3 to 4 per cent., and the *FeO* plus *MnO* increased by about the same amount, making it more suitable to carry the large amount of *ZnO* present.

TABLE 1. ANALYSIS OF PRODUCTS AT VARIOUS STAGES DURING ROASTING, SINTERING, AND SMELTING

	<i>Pb</i> Per Cent.	<i>Ag</i> Ounce Per Ton	<i>Ar</i> Ounce Per Ton	<i>Cu</i> Per Cent.	Insol. Per Cent.	<i>SiO₂</i> Per Cent.	<i>FeO</i> Per Cent.	<i>MnO</i> Per Cent.	<i>CaO</i> Per Cent.	<i>Al₂O₃</i> Per Cent.	<i>Zn</i> Per Cent.	<i>ZnO</i> Per Cent.	Sulphur				<i>Pb</i> as <i>PbSO₄</i> Per Cent.	
													Total Per Cent.	As Sulphide Per Cent.	As Sulphate Per Cent.	As <i>PbSO₄</i> Per Cent.		
Raw concentrates	42.98	22.90	.0100	.166	21.25	10.80	5.84	6.27	1.60	4.30	11.05							
Silicious ore to roasters	8.49	17.40	.0150	.110	71.00	57.60	9.32	8.66	1.92	7.70	trace							
Roasted material to converter	34.97	20.35	.0100	.160	19.02	11.75	7.57	5.47	6.70	4.40	8.63	10.75	8.45	5.75	2.70	.96	4.20	
Roaster product	28.32	13.12	.0075	.150	15.35	10.10	7.38	3.11	6.65	3.15	4.36	5.98	10.20	4.07	6.13	3.50	22.70	
Sintered product	35.92	21.70	.0075	.140	15.12	12.67	7.38	5.66	6.65	3.80	8.72	10.86	3.94	1.34	2.60	1.68	10.90	
Converter flue dust	35.34	20.43	.0100	.098	17.96	11.15	6.04	3.32	5.46	4.00	7.12	8.87	7.79	4.64	3.15	1.43	9.30	
Smelter flue dust	32.10	9.50	.0010		26.50		8.10	1.80	3.00	2.10			5.24	4.14	1.15			
Smelter slag	1.73	.59				26.90	26.20	7.90	16.20	4.50		12.50	2.90					
Smelter bullion	98.80		.0440	.340	.23							.05	.38					
Copper dross	80.40	31.60	.0380	5.520								.86	6.24					
Ironstone					3.00		8.50	.50										
Limestone					2.00				54.00									

* Insol. as *Sb*, etc.

mation of silicates. For this reason charges of Huntington-Heberlein sintered material, or ore containing a high percentage of zinc, should contain sufficient uncombined silica so as to produce a high temperature slag, but at the same time this slag must be high in *FeO* or *MnO*. A high temperature zincy slag causes little trouble at the tap hole, and the high temperature also keeps the crucible in a healthier condition.

The accompanying Table 1 shows the analysis of product at various stages during the roasting, sintering, and smelting operations, and is typical of the working of the Huntington-Heberlein process during the early stages of its career at the works.

At a later stage the following may be taken as typical of the smelting:

Charge	Pounds	Slag	Per Cent. Per Ton
Huntington-Heberlein sintered concentrates	2,400	<i>SiO₂</i>	26.0
Sintered slime	800	<i>FeO</i>	30.0
Oxidized ore	300	<i>MnO</i>	6.0
Ironstone	700	<i>CaO</i>	16.0
Limestone	600	<i>Al₂O₃</i>	5.9
Returned slag	800	<i>ZnO</i>	12.0
		<i>PbO</i>	1.6
Total	5,600	<i>Ag</i> , ounce per ton	S
Coke	900		

The sintered slime or concentrate did not contain enough sulphur to sever from matter during smelting. The fact has since been made use of to treat an appreciable amount of raw concentrate. At the present time the following may be taken as typical of the furnace work*:

Charge	Pounds
Sintered slime	1,000
Converted concentrate	2,000
Raw concentrate	200
Old slag	800
Ironstone	1,050
Limestone	550
Total	5,600
Coke	840

The charge carries about 17 per cent. of lead. The recovery is about 95 per cent. of lead, 98 per cent. of silver, and practically all the gold.

Slag: *SiO₂*, silica, 25 per cent.; *FeO*, ferrous oxide, 33 per cent.; *MnO*, manganese oxide, 6 per cent.; *CaO*, calcium oxide,

* Delprat, Trans. Aust. I. M. E., Vol. XII, page 19.

The operation of blowing in a blast furnace at Port Pirie is so timed that it is ready for the blast to be put on early in the day shift. On the previous day shift, or earlier, all the jackets and tuyeres are replaced, and the air and water connections made, with the exception that the tapping jackets at both ends are for the present omitted, and a tuyere sleeve at each end is attached to a 3-inch galvanized tube to be used in supplying a forced draft of air to the wood fire in the crucible, which is kept going during the afternoon shift so as to thoroughly heat the crucible. If the crucible has been freshly built in, a small wood fire is maintained for a day or two to dry it before it is strongly heated ready for blowing in. During the night shift a strong wood fire is maintained, and at the same time 500 to 600 bars of smelter bullion are melted down into the crucible. The wood ashes are raked out from time to time, and a final and complete raking out takes place at the close of the shift. As much firewood as possible is then fed in through the space for the tapping jackets, which are then built in and attached to the water service, and the separating bows and spouts fixed in position. While the heating of the crucible and running down of the bullion has been proceeding, blowing-in charges have been weighed out and stacked closely round the mouth of the furnace on the feed-floor, so that the shaft may be filled with as little delay as possible. The requisite amount of coke is weighed, bagged, and placed on its respective charge. The following charge may be taken as typical of blowing in a large furnace:

	Pounds
Firewood	about 1 ton
Coke	3,200
Slag	2,000 } 20 charges, with 3 bars to
Coke	670 } each charge.
Slag	2,000
H.-H. mixture	1,200
Kaolin ore	1,000 } 20 charges, with 3 bars bullion
Ironstone	800 } to each charge until bullion
Limestone	600 } (about 100 bars) is finished.
Coke	670

As soon as the tapping jackets are placed in position the extra firewood is thrown down, followed by a large charge of coke alone, then by 20 slag charges, each with three (sometimes five) bars of bullion with charge. This is followed by about 20 easy smelting ore-with-slag charges, each with extra bullion bars, until the supply of bullion is finished. The regular ore charges are then commenced and continued. The object of the bullion added to the slag and early ore charges is to give a stream of hot lead into the crucible to restore and increase the temperature of the molten bullion, which has been losing heat since the running down was completed. By the time the tapping jackets have been built in, connected to

water connections, etc., spouts placed in position, and the rest of the wood thrown in, molten slag from another furnace is poured on it to light the firewood, and the shaft charged to a considerable height. A gentle blast is now allowed in through the tuyeres, and is progressively increased as the charge of wood and coke is fully alight and as the column of charge is raised. The furnaces require careful handling for several shifts until they settle down to normal work. Great care is exercised only to draw off lead from the lead wells when it is showing in the tap holes at the ends. If much lead is early drawn off it may cause the whole column of charge to slip down the smooth side of the furnace, and to then force out a further and undue amount of lead bullion. The partly fused bottom of the charge will then be forced down below the fusion zone, and remain as an exceedingly troublesome crust over the crucible, resulting in greatly decreasing the working capacity of the furnace. When there are spare furnaces it is sometimes better to blow in another and then blow out the sick furnace.

Incrustations form on the side of the furnace and have to be removed from time to time. The usual procedure is as follows: The furnace is fed down on slag charges until the top of the charge

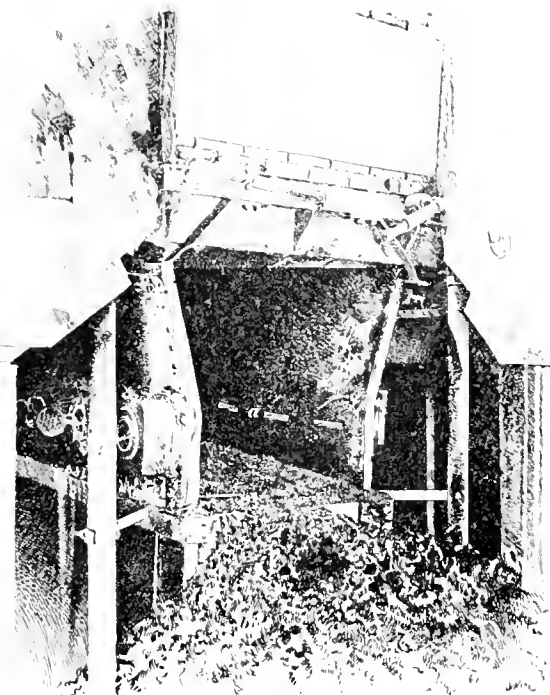

FIG. 5. FURNACE WITH JACKET REMOVED

is down to the jackets. The furnace is drained as dry as possible of liquid slag and the wind then taken off. A large charge of coke is then fed in, and on the top of this is usually placed scrap iron. The incrustation is barred and worked off by means of long bars, further coke and scrap iron being added from time to time as the barrings accumulate in the bottom of the furnace. When the incrustation is removed, or as much as the accumulated barrings will allow, the furnace is filled up and restarted. If the furnace was badly encrusted, it may be necessary to run it down a second time as soon as the barrings have been smelted out. The slag produced at such time is foul, so it is saved, to be returned as the slag constituent of the charges.

When blowing out, the furnace is fed down with slag charges—i. e., charges of slag and coke are added, and at the same time the height of the charge column is allowed to lower and the blast is reduced. During the latter part of the lowering of the surface of the charge the feed-openings are covered over and water played on to the floor plates to keep them from becoming too hot. The column is lowered as far as possible, the slag drained out and the blast taken off, the tapping jackets removed, a hole cut down

through the charge and crust into the crucible, and all the lead possible dipped out. The end jackets are then removed, and the remaining charge raked out. The rest is watered, allowed to cool, and then removed by chisels.

At the Cackle Creek works the practice is briefly as follows: Besides smelting lead concentrates from Broken Hill these works do a large custom business in ore and concentrates of gold, silver, and lead. Their practice is consequently more elastic to suit the conditions, and not so sharply defined as at Port Pirie. The roasting of the Huntington-Heberlein mixture is done in Godfrey revolving-hearth furnaces. The roasted mixture is converted in large conical pots. The sintered mixture is smelted in a furnace 120 in. \times 50 in., at the tuyeres, and 36 feet from tapping to feed-floor. The blast is supplied by a large electrically driven positive blower, at a pressure of about 60 ounces. The furnace is provided with a central uptake flue, as in the Port Pirie furnaces—the latter, however, having been installed owing to the very successful working of the Cackle Creek furnaces. The bullion is tapped into pots, taken to and poured into a drossing furnace, from which the bullion is run out into molds in a circular molding machine. The bars while still molten are skimmed, and when solidified are tipped out, sampled, and shipped to Europe for further treatment. The dross from the drossing furnace is returned to the blast furnace. The slag is run out into large pots holding about 4 tons. The pots are poured by rotating them by gearing. The skulls left in the pots are used for returned slag on the charge.

來 來

History of Kansas Oil Development

By L. L. Wittich

In 1850, or near that date, pioneers in Eastern Kansas learned from Indian "medicine men" that oil seeps were not uncommon in certain localities. The redskins used the thick, black petroleum for medicinal purposes. Legendary stories are told of the great warriors holding their councils around the lights of mysterious burning springs. Gas seepage, instead of oil, was often accountable for the strange, flickering fires that often wavered back and forth over acres of ground. One of the most notable burning springs in the Mid-Continent field is found in the northeastern part of Pittsburg County, Okla., about 20 miles northeast of McAlester. At this point gas escapes from crevices that zig zag across an area much larger than a city block. On either side rise high, rocky bluffs. When ignited, the gas burns for weeks or even months. Conforming with the theories of the majority of geologists, it is significant to note that this natural gas seepage occurs near the crest of an anticline. Prospecting near the area of gas seepage has revealed no oil, and very little gas, the great bulk of the natural reserves having escaped during the countless years that the seepage has been in progress. Many similar seepages, both of gas and oil, are found throughout Oklahoma and Kansas. Even as far east as Tar Creek, in Kansas, only about 20 miles west of Joplin, Mo., oil seepage is found along the banks of the stream.

The occurrence of oil on the surface led the early settlers of Kansas to investigate, and in 1860 Dr. G. W. Brown began a prospecting campaign east of Paola. From this time on, spasmodic efforts were made to develop the petroleum fields, the importance of which began to be appreciated, until 1890, when the first real development in Kansas was undertaken. The first natural gas was piped into Neodesha, Kans., and lighted on the evening of July 4, 1894, a great celebration being held in honor of the event.

While the oil industry of Oklahoma is yet in its infancy, so is the oil production of the world, the first deep drilling for the purpose of securing petroleum having been started at Titusville, Pa. Success crowned this venture, other wells followed rapidly, and the production of oil became a remunerative occupation. Ohio, Indiana, and Illinois were among the first states to figure as oil producers; then came Kansas, Texas, California, and Oklahoma, the production of the latter state now being eclipsed only by California, where cooperation on the part of producers has worked wonders in the development of the western fields.

Mines and Minerals

Vol. XXXII—No. 7. SCRANTON, PA.—FEBRUARY, 1912—DENVER, COLO. Price, 25 Cents

PUBLISHED MONTHLY AT SCRANTON, PA.

ESTABLISHED 1881

WESTERN EDITORIAL OFFICE: 1221-1222 First Nat'l Bank Bldg., Denver, Colo.
CHICAGO OFFICE: 1006 Michigan Ave.

Entered at the Post Office at Scranton, Pa., as second-class matter
Address all business communications to MINES AND MINERALS, Scranton, Pa.
CABLE ADDRESS, "RETSOP, SCRANTON"

LONDON OFFICE: INTERNATIONAL BUILDINGS, KINGSWAY, LONDON, W. C.
SOUTH AFRICAN OFFICE: MANSION HOUSE CHAMBERS, ALDERLEY STREET,
CAPE TOWN.

NEW ZEALAND OFFICE: 63 DIXON STREET, WELLINGTON.
AUSTRALASIAN OFFICE: 53 PITT STREET, SYDNEY.

SUBSCRIPTION RATES

Single Copies.....25 cents
Yearly Subscriptions, including postage:
To United States, Mexico, Cuba, Porto Rico, Hawaii, and Philippines \$2.00
To Canada.....2.50
To all other countries.....3.00
The date after your name on the wrapper is that of the month to which your subscription has been paid. If you do not want to continue your subscription after that time, kindly notify us.
Notice to discontinue or change of address should be sent to the Scranton office.
When notifying us of a change of address always give your FORMER as well as your present address.

TABLE OF CONTENTS

EDITORIAL—	
Flushing or Silting Mine Workings—Zinc Mining in Missouri.....	385
COAL MINING AND PREPARATION	
MINE No. 3, SALINE COUNTY COAL Co., by Oscar Cartledge.....	387
COAL WASHING AT LAHAUSAGE, by Day Allen Willey.....	391
TRADE NOTICES.....	392
CROSS MOUNTAIN MINE EXPLOSION.....	393
PURCHASING LOCOMOTIVE FUEL.....	398
COAL MINING NOTES.....	399
CORRESPONDENCE—	
Grades for Rope Hauls—Allowable Error in Closing Survey—Coal Dust—Siphons.....	401
METHOD OF MINING, by Wm. Griffith.....	402
VENTILATING BLIND CHUTES IN GASEOUS MINES.....	403
WIRE ROPE AS APPLIED TO MINING.....	404
OXYGEN STRETCHER.....	406
CATALOGS RECEIVED.....	406
PERSONALS.....	407
COKE MAKING IN ITALY.....	408
AUTOMATIC SWITCH FOR SHAFT BOTTOMS.....	408
RELIEVING ACCUMULATIONS OF GAS, by W. H. Cunningham and C. R. Con- nor.....	409
BOOK REVIEW.....	410
MINE MANAGEMENT DIAGRAM.....	411
WORKMEN'S LIABILITY INSURANCE, by C. O. Bartlett.....	412
SHAFT BOTTOM AT ARENBERG MINE.....	413
FIRST MINING SCHOOL IN ENGLAND.....	414
SPONTANEOUS COMBUSTION OF COAL.....	414
HOISTING BY ELECTRICITY, by J. J. Barnes.....	416
QUICK TAPE REPAIR BANDS.....	416
EXAMINATION QUESTIONS—	
Mine Formen Indiana, 1911—Firebosses, Indiana, 1911.....	417
ORE MINING AND METALLURGY	
BAUXITE MINING IN TENNESSEE, by George H. Ashley.....	419
A REMARKABLE HOME-MADE MINING PLANT, by Frank C. Perkins.....	421
PLACER MINING IN QUEBEC, CANADA.....	422
REFINING OF BASE BULLION, by W. Poole.....	423
QUICKSILVER WORKS IN AUSTRIA.....	427
ROTARY TRAY CONCENTRATION, by Al. H. Martin.....	428
CUTTING AND BENDING GLASS TUBES.....	429
GEOLOGY OF THE BRECKENRIEGE PLACERS, by Arthur Lakes.....	430
ORE MINING NOTES.....	433
ZINC-LEAD PRODUCTION OF MISSOURI, KANSAS, AND OKLAHOMA, 1911.....	433
THE GIROUX MINE FIRE, by H. H. Sanderson.....	435
COBALT, ONTARIO, SILVER SHIPMENTS, 1911.....	436
SIXTEEN TONS OF HIGH EXPLOSIVES IN A BLAST, by Frank C. Perkins.....	437
MINERALS COMMON TO SILVER DEPOSITS, by W. G. Matteson.....	438
MINERAL OUTPUT OF THE WORLD.....	442
MINING ORE AT THE TALISMAN MINE, N. Z.....	443
CANADIAN MINING INSTITUTE.....	447
THE JOPLIN DISTRICT IN 1911, by L. L. Wittich.....	447
IRON ORE IN 1911.....	448
SQUIBS—	
Petroleum in South Africa, 399—Bolivia's Tin Production, 1911, 421— Report of the Broken Hill South Silver Mining Co., 426—Cooper- ative Drainage, 436—The Modern Flint and Steel.....	440

Flushing or Silting Mine Workings

IN OUR last issue we showed conclusively that the credit for originating the flushing or silting of mines with sand, culm, or other suitable material, was due to American mining engineers, who used the method at least 15 years prior to its adoption by Silesian engineers. In the same article we gave the late R. C. Luther credit for conceiving the idea and of first putting it to practical use at the Kohinoor colliery, at Shenandoah, Pa.

A few days ago Mr. Eli T. Conner, mining engineer, informed the writer that Mr. Frank Pardee, general superintendent of the collieries of A. Pardee & Co., Hazleton, Pa., told him that he thought he (Mr. Pardee) had used the method about a year previous to its adoption by Mr. Luther.

We accordingly wrote Mr. Pardee for further information and he kindly furnished us with an original letter written by the late P. W. Sheaffer on February 19, 1887, to Mr. Calvin Pardee, who was general superintendent of the collieries of A. Pardee & Co., in the Hazleton region. Mr. Frank Pardee was at that time his assistant.

Mr. Sheaffer was part owner of the coal land being worked at the Kohinoor colliery, and was an eminent coal geologist. It is probable that the land owners paid a part of the expenses for flushing the culm into the Kohinoor workings and the object of Mr. Sheaffer's letter was to learn if Mr. Pardee's method of accomplishing the work possessed any features that were less expensive or more efficient than the plans proposed by Mr. Luther.

Mr. Sheaffer's letter was as follows:

POTTSVILLE, Pa., Feb 19, 1887

MR. CALVIN PARDEE,
Hazleton, Penna.

MY DEAR SIR:—Will you oblige us with your mode of filling cavities in mines with coal dirt, as we now learn you are doing? We have just started a bore hole 8 inches diameter in Shenandoah, about 400 feet down to large open space in main bed, into which we want to run culm with water. The dirt bank is about 1,500 feet distant and up hill. If we shall run dirt in cars or scrapers, and how to do it is our query. If you can advise us of your plan and how to prevent its spread in the mines below, you will greatly oblige.

Yours truly,
P. W. SHEAFER

Mr. Calvin Pardee made a pencil notation on this letter as follows:

Frank, will you please reply to this.

CALVIN PARDEE

Mr. Pardee, in addition to Mr. Sheaffer's letter, sent us the following statement:

In the latter part of 1885, we had an extensive squeeze in the second and third levels in our Laurel Hill (Hazleton No. 5) mine.

It was creeping slowly toward the west and it passed our timbering as fast as we put it in place. I then suggested to my father and brother that we select two breasts east of the slope and bore holes into them. (The first hole was finished January 29, 1886, and the second one March 8, 1886.) The coal seam had a heavy pitch, so we placed across the chutes, just below the batteries, strong dams which would keep the culm from running out of the breasts, but which would allow the water to drain through. We then, through the bore holes, filled the breasts, using the material direct from the breaker, conveying it to the holes through water troughs. The work was practically finished at the time Mr. Sheaffer wrote my brother. When the squeeze reached the breasts filled with culm, it stopped.

I think as Mr. Sheaffer's letter is dated February 19, 1887, and the work at the Kohinoor colliery was the first experiment of the kind in the Schuylkill region, and while the surveys for the location of the Kohinoor holes were made in 1886, the holes were not finished and put in operation, as far as flushing is concerned, until 1887. Therefore, to the best of my knowledge and belief, mine was the first experiment of the kind in the anthracite coal fields.

As Mr. Sheaffer was one of the most interested persons in the success of the Kohinoor flushing, and his letter dated February 19, 1887, infers that the flushing had not actually commenced at that date, it is evident that Mr. Pardee's work at Hazleton antedated that at the Kohinoor colliery, and he is, therefore, entitled to the credit of being the originator of the method in the anthracite coal fields, and, as far as we can learn, in any other coal field.

A peculiar circumstance, is the fact that Mr. Luther must have personally conceived the same idea a few months or a year after Mr. Pardee did, as is evidenced by the phrase "*as we now learn you are doing*" in Mr. Sheaffer's letter, which was not written until after Mr. Luther's plans were well under way. This shows that Mr. Pardee's successful use of the plan was not known by Mr. Luther or Mr. Sheaffer prior to February, 1887.

That the flushing of culm into mine workings at an American mine, for another purpose, occurred at a still earlier date is evidenced by the following information kindly furnished MINES AND MINERALS by Mr. Geo. S. Clemens, mining engineer, of the Philadelphia & Reading Coal and Iron Co.:

At our Buck Ridge colliery, near Shamokin, Pa., on August 20, 1884, a fire broke out in the main hoisting slope in the bottom split of the Mammoth seam (the Mammoth seam in this locality being split into two seams with enough rock between to enable them to be worked as two distinct seams). There were six lifts off this slope, three above water level, and three below water level. The slope was 440 yards long, varying in pitch from 35 degrees at the top to 45 degrees at the bottom, of which the upper 350 yards was on fire, with flames bursting out of the top, to a height of 50 feet. The top was with difficulty covered with plank and earth until pumps, etc., could be installed for flushing the slope with culm. Twenty-two thousand five hundred cubic yards of culm, with 1,000 gallons of water to the cubic yard of culm were flushed into the mouth of the slope and the fire was extinguished. The idea was originated by the late John Veith, the general mine superintendent of the company, and I believe it was the first instance of mine flushing with culm.

If any of our readers can furnish evidence of the flushing of mines prior to the instances already recorded we will be glad to receive it, and if it is conclusive we will

cheerfully accord the credit of originating the idea. As the evidence now stands, Mr. Pardee was the first to flush culm into a mine to support the overlying strata, and the late John Veith was the first to flush it into a mine for another purpose.

來 來

Zinc Mining in Missouri

A CASUAL question relative to zinc mining in Missouri produced such a flux of pessimistic words, a layman with his eyes shut could surmise that the speaker had gotten in the wrong mining company. Among the scandalous things said, one was that "Mining in Missouri was like hunting for a needle in a hay stack," from which it may be inferred that the particular kind of mining which had the esteemed considerations of the speaker consisted in driving rock headings indiscriminately for something that he had not been able to find.

The risks connected with zinc ore mining have been minimized by Missourians practicing their motto, "You must show me." Nevertheless, whoever ventures in zinc mining will necessarily engage in a somewhat doubtful investment. The monetary risks involved in metal mining, comparatively speaking, increase in direct proportion to the market value of the metal, while the profits usually increase in the inverse ratio.

To illustrate, zinc is 12 times as difficult to find and prepare for market as iron ore; silver is 200 times as rare and expensive as zinc; while gold is from 16 to 22 times as rare as silver.

In the Kansas-Missouri-Oklahoma zinc field there is money made in mining, for at the beginning of 1912 over 500 different properties were being prospected and a large number of abandoned mines were being reopened. What was called zinc mining in the past, was in reality "wild catting," as it consisted in leasing a piece of property—supposed to have zinc somewhere within its surface lines because on another piece of property in the vicinity zinc was found, and in sinking a shaft from which drifts radiated in several directions.

The old system of procedure has given place to a more intelligent method of operation, which, if it is not always successful in results, at least reduces the loss to a minimum.

Instead of sinking a shaft for prospecting purposes, drills are used, with the chances of finding ore increased about 25 times; that is, one drill hole will cost one-twenty-fifth as much as a shaft. Instead of sinking a shaft for prospecting, that may prove blank, and then driving headings in barren ground in several directions, drills are requisitioned to find the deposit and its extent prior to shaft sinking and drifting. All the experience derived from years of mining and intelligent observation in Missouri has reduced zinc mining risks to an extent where smelting concerns, which are always anxious and ready for the miner to assume all the risks, have entered into the game.

COAL MINING AND PREPARATION

Mine No. 3, Saline County Coal Co.

Method of Fireproof Construction of Shaft—Handling Cars. Method of Mining

By Oscar Carlidge

A recent development in the Southern Illinois coal field is the No. 3 mine of the Saline County Coal Co., located 1 mile west of Harrisburg. This company has for a number of years operated mines in the northern part of the state, and for the past 5 or 6 years has had two large mines in Saline County.

C. I. Pierce is president; William Johnson, general superintendent; George Morris, superintendent; R. Williams, engineer; with the main offices located in the Peoples Gas Building, Chicago.

The coal mined is geologically known as No. 5 bed of the Illinois Survey, and extends practically throughout the county, Harrisburg approximating the geographic center. It ranges in thickness from 4½ feet at the north end of the county to 8 feet at the south; has no dirt or blue band, is very free from impurities, has a hard strong roof, with a draw slate running in thickness from nothing up to 8 inches, and a hard dry floor. The average dip to the north is about 40 feet to the mile, and at the No. 3 mine the overlying strata are 275 feet thick.

The No. 7 coal bed, which lies about 170 feet above the No. 5, and which averages 4 feet 10 inches in thickness, also exists throughout the field, but is not at the present time being mined to any considerable extent.

At No. 3 mine the coal bed No. 5 is 8 feet thick, has practically no draw slate over it, and has so far developed no slips or faults. An analysis of the coal reveals the following: Moisture, 3.74; volatile matter, 38.21; fixed carbon, 52.01; ash, 6.04; total, 100. Sulphur, 1.02; theoretical British thermal units, 13,950; theoretical evaporation, 14.41 pounds of water per pound fuel; practical evaporation, 8.95 pounds of water per pound fuel.

An act of the General Assembly of Illinois, approved and in force March 8, 1910, entitled "An Act to require fire-fighting equipment and other means for the prevention and controlling of fires and the prevention of loss of life from fires in coal mines," after specifying certain stringent regulations for mines then in operation, beginning at Section 6, reads as follows: The following requirements also shall apply to all coal mines developed within the state of Illinois after the passage of this act: Provided, that paragraphs (a) and (b) shall not apply to mines where 10 men or less are employed.

(a) The hoisting shaft and the air and escapement shaft, designated as such under the law in shaft mines, and the air and escapement shaft nearest the main opening in slope or drift mines, shall be of fireproof construction, except the cage

guides may be wood. Provided, that this section shall not apply to shafts in actual course of construction at the time this Act takes effect.

(b) The roof and walls of the passageway leading from the bottom of the hoisting shaft and the air and escapement shaft, designated as such under the law, within a distance of 300 feet from the bottom of either of said shafts, shall be of fireproof construction, except that the coal rib or pillar may be used as a wall in such passageway.

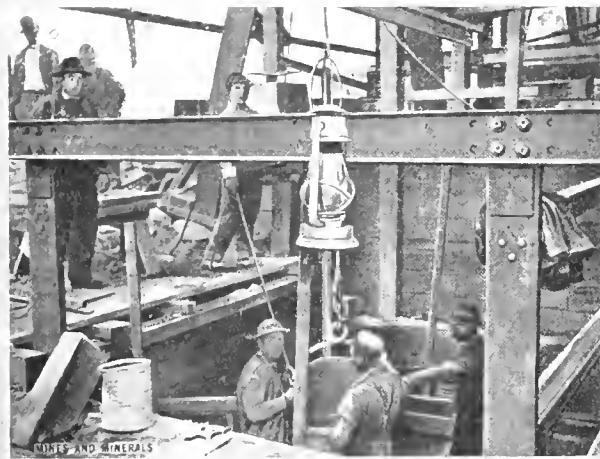

FIG. 1. FIREPROOFING MAIN SHAFT



FIG. 2. DRESSING THE CONCRETE FIREPROOFING



FIG. 3. TOP OF SHAFT, COMPLETED

(c) All underground stables and the openings therein shall be of fireproof construction.

(d) At mines constructed in conformity with the requirements of this section of this Act, the fire-fighting equipment described in Section 2, and the fire drill described in Section 5 of this Act shall not be required, except that there shall be kept at convenient places, designated by the mine manager, throughout each mine, one not less than 3-gallon chemical fire extinguisher,

should develop mines after March 8, 1910: All shafts over 50 feet in depth shall be lined with concrete for a distance of not less than 25 feet from the top downward, and not less than 25 feet from the bottom upward. The space between may be timbered with wood and covered with non-expanding metal covered over with fireproof cement; and all shafts 50 feet or less in depth shall be constructed of concrete or brick from top to bottom. In all shafts the buntons shall be of steel.

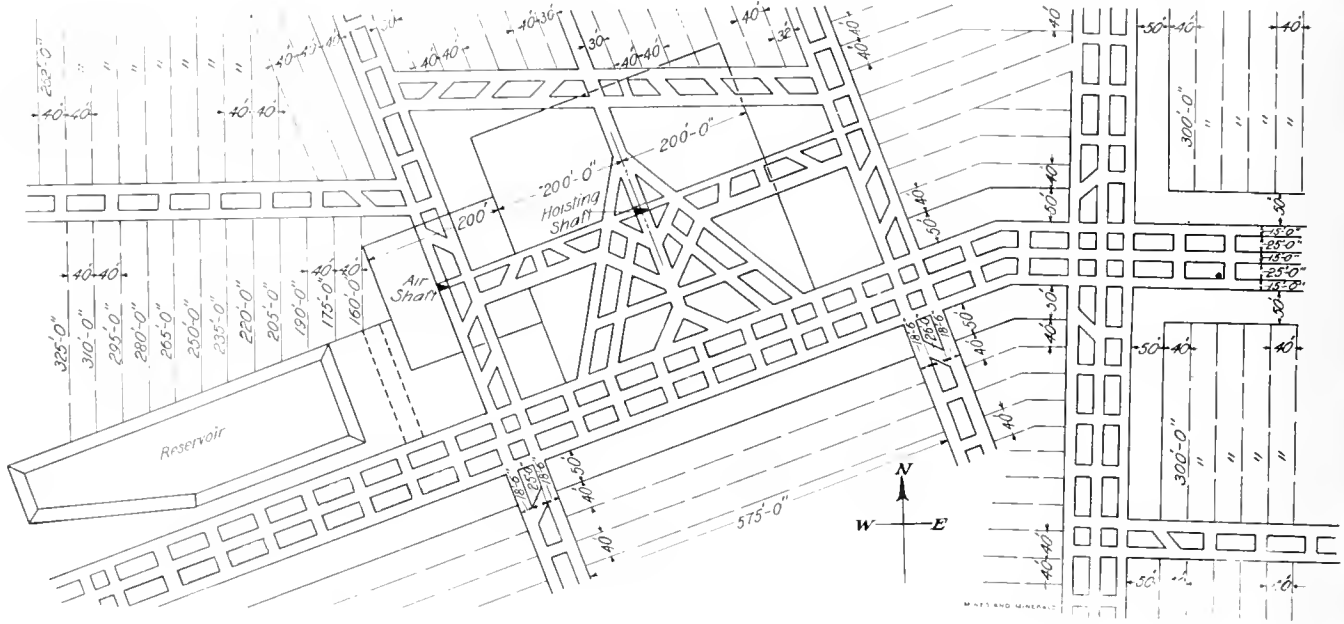

FIG. 4. DEVELOPMENT PLAN, MINE NO. 3, SALINE COUNTY COAL CO.

and one not less than 6-gallon hand-pump bucket for each 50 employes in the mine, with a minimum of six extinguishers and six pump buckets, and such extinguishers and buckets shall be kept filled and ready for use: Provided, that in mines employing 10 men or less underground, the chemical fire extinguishers shall not be required.

Owing to the many interpretations placed upon the phrase "fireproof construction," soon after the passage of the act the State Inspectors of Mines met, and, in order to arrive at some degree of uniformity, adopted the following rule to be observed by all who

The Saline County Co.'s No. 3 mine was not begun until the summer of 1910, and therefore came under the provisions of Section 6.

In conformity to the law and the rule of the inspectors, the main shaft and the air-shaft, which are 10 ft. X 20 ft. and 10 ft. X 14 ft., respectively, in the clear, were carried down through the soil to the rock, or rather to No. 7 seam, with timber set about 2 feet outside of the intended clearance of the shafts, as shown in Fig. 8. From there down to the No. 5 the strata are of such a nature that no timbering is required to support the sides, and the

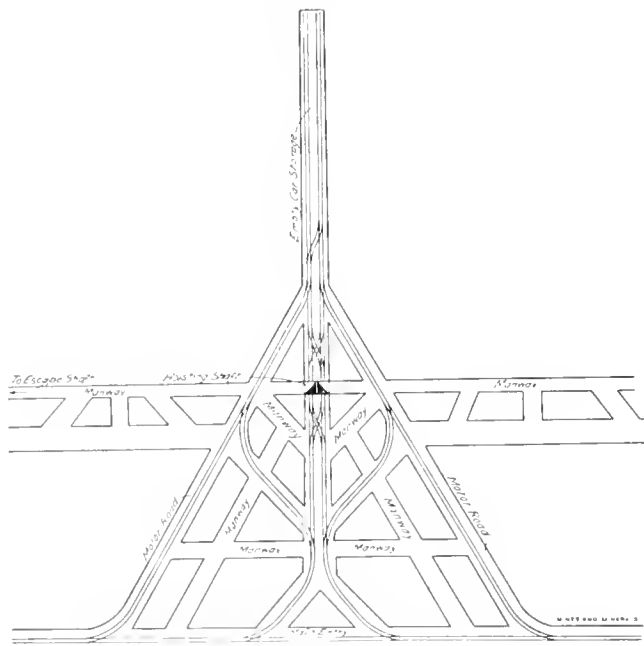

FIG. 5. PLAN OF SHAFT BOTTOM

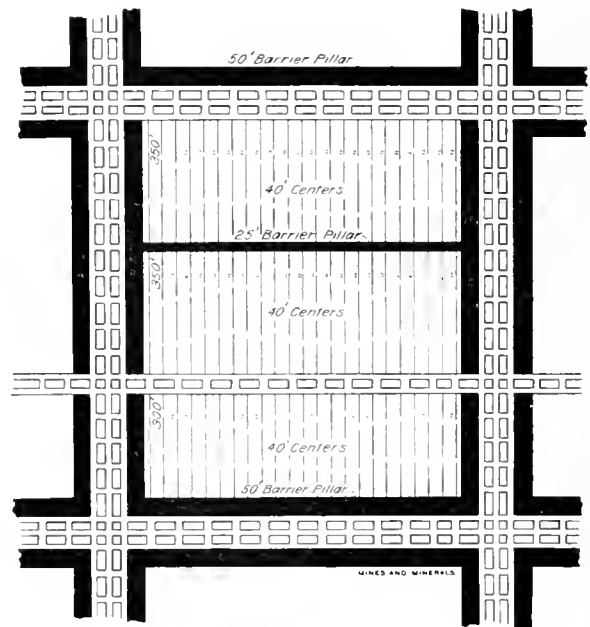

FIG. 6. METHOD OF WORKING

shafts were stepped in to the required dimensions. Precautions were taken to not shatter the walls, by placing the blasts well in, and then trimming with pick and wedge. At the main shaft when the top of the coal was reached the rock was cleaned off and sinking ceased.

Beginning at the step-off and placing removable iron doors over the No. 7 coal bed so that it would be easy of access in case it was ever wanted to develop same, a 2-foot wall of reinforced concrete was carried up to about 5 feet above the level of the ground.

The coal hoisting was continued from the air-shaft until the top equipment, which was under course of construction all of this time, was completed. Then operations were reversed, coal being hoisted from the main shaft while the escapement shaft was being fireproofed.

At the time hoisting was discontinued at the air-shaft over 500 tons of coal per day of 24 hours were being raised.

Everything on the surface is fireproof, as shown in Fig. 7. The main building, which houses the hoisting engines, generators, boilers, pumps, etc., is 134 ft. x 60 ft., and is built of brick with a solid brick partition between the engines and boilers.

The engine room contains a pair of 24" x 36" first-motion Danville hoisting engines with a 6-foot single-spool drum; a three-panel marble switchboard with the usual equipment; one 100-kilowatt Ridgway generator, direct connected to a Ridgway engine, and one 300-kilowatt 275-volt generator, direct connected to a 26" x 24" automatic engine.

In the boiler room there are four 150-horsepower horizontal tubular boilers, with space for two more; a feedwater heater with feed-pumps and other necessary accessories.

The smoke stack is 7 feet in diameter and is constructed of concrete for a distance of 20 feet, capped with 105 feet of steel.

Coal is delivered to the boiler room by a steel conveyer drag extending from the screens.

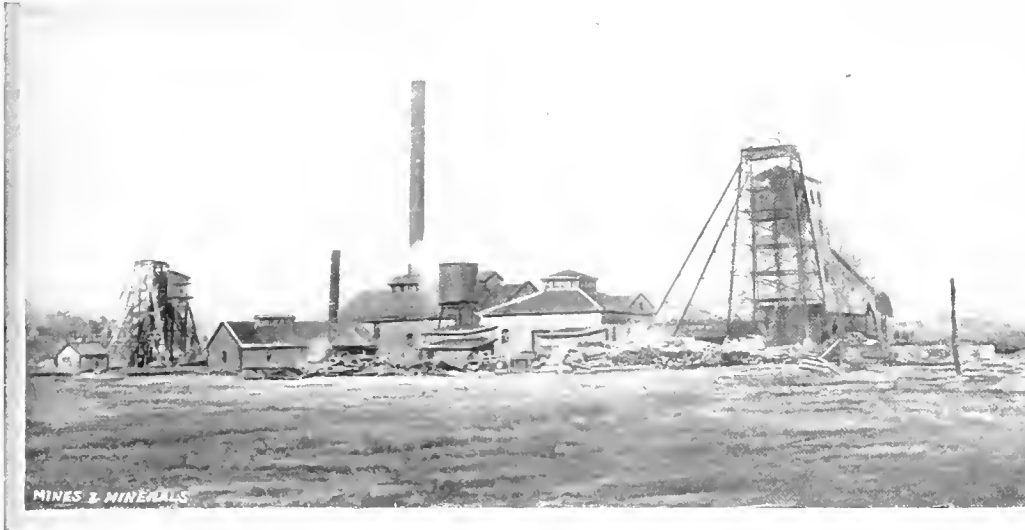

FIG. 7. SURFACE PLANT, MINE NO. 3, SALINE COUNTY COAL CO.

Figs. 1 and 2 show the work in process of construction and Fig. 3 its completion at the surface. In order that the temporary cage guides in the escapement shaft might be supported and held in place, temporary wood buntons were hitched into the rock and secured by wedges tightly driven at the ends. These buntons were later removed and the hitches used to good advantage on the manway side in building the concrete separation wall shown in longitudinal section, Fig. 8.

In building this wall, where every other buntan had been hitched there was securely fixed a section of 20-pound steel rail; and running perpendicular to the shaft, and at right angles to these, were placed 3/4-inch square-twisted rods, interlapping the rails, and at a distance apart of about 10 inches. A 6-inch form was made; concrete rammed in, and after it had hardened the form was removed.

This reinforced wall was carried up the entire length of the shaft, and makes a substantial and air-tight partition between the manway and the air compartment.

As no water is found below the No. 7 coal the concrete lining effectually dams back the water and the stairway is perfectly dry.

Complying with the law requiring that the roof and passageways leading from the bottom of the hoisting shaft and the air and escapement shaft, within a distance of 300 feet from the bottom of either of said shafts, shall be of fireproof construction, steel I beams were placed 4 feet apart and roofed over with steel plates, the whole making a solid steel roof, with the I beams having the support of solid concrete walls extending the entire distance on either side of the passageways.

It should be mentioned that while the work was under construction in the main shaft, coal was being hoisted at the air-shaft; the work proceeding continuously with three shifts of 8 hours each. The fireproofing, trimming of walls, placing the buntons, guides, etc., in the main shaft occupied about 3 months, during which time the connecting passageway from the escapement shaft was driven up to within 7 feet; a 3-inch hole was drilled upward at an angle of about 40 degrees; a pipe, with valve inserted, and the water which had accumulated in the main shaft to a depth of nearly 60 feet was allowed to flow into the passageway, where it was taken care of by a pump located near the bottom of the air-shaft.

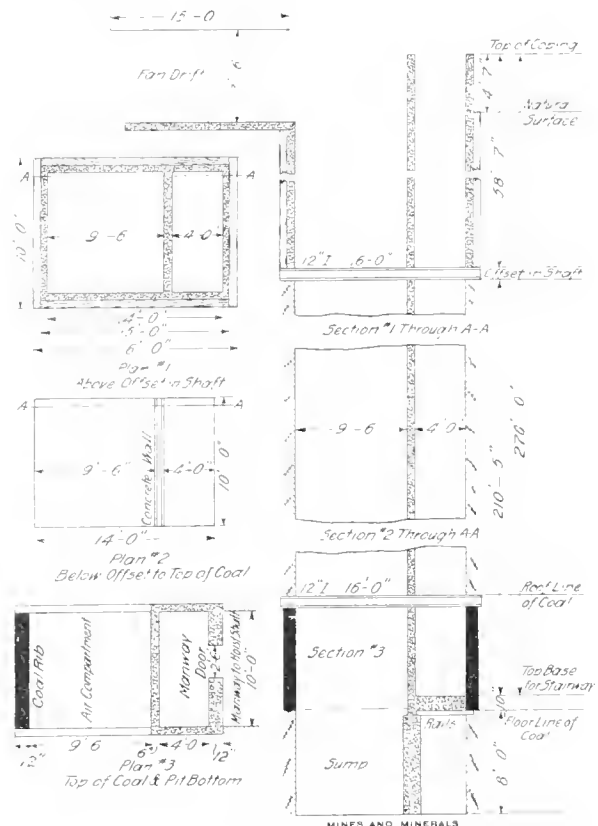

FIG. 8. PLANS AND LONGITUDINAL SECTIONS OF AIR SHAFT

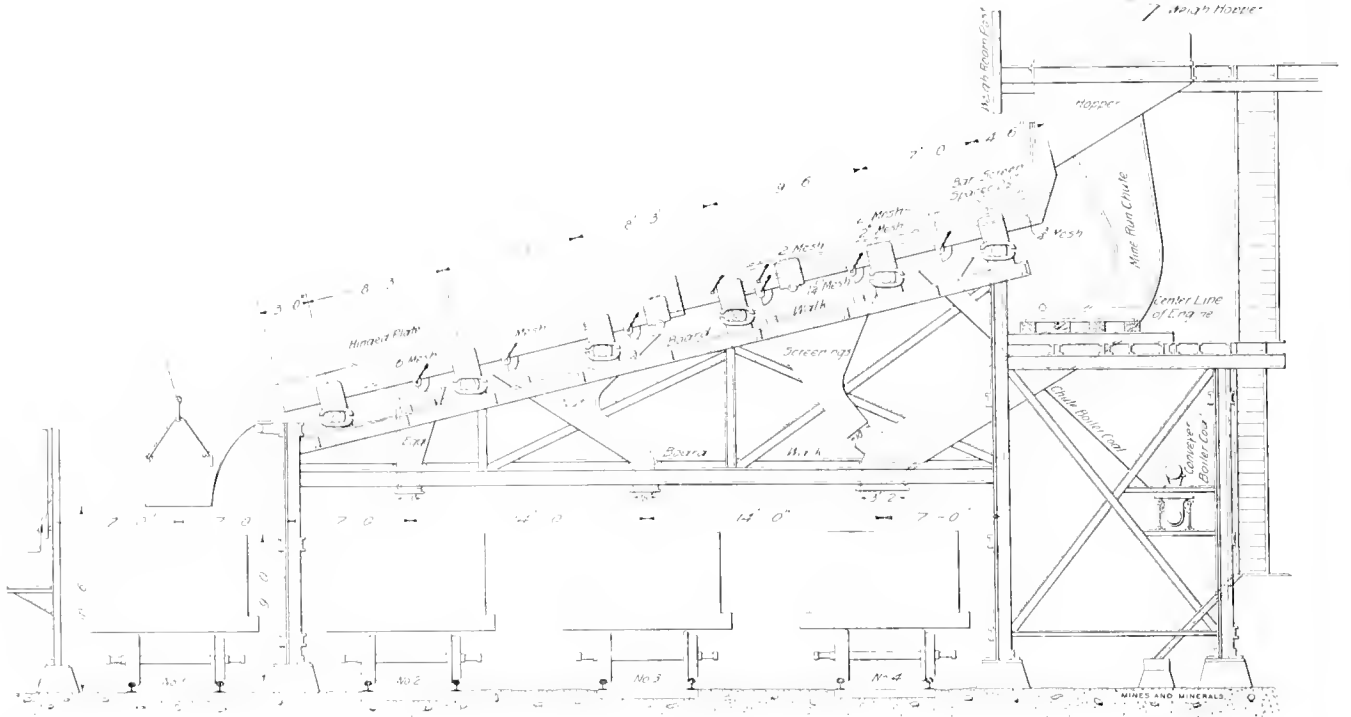

FIG. 9. SHAKER SCREEN

TABLE 1. INSTRUCTIONS ACCOMPANYING BLUEPRINT OF SHAKER SCREEN, MINE NO. 3

Plates							Remarks
Number	Size	Mesh	Screening Surface	Area Square Feet	Number Perforations	Per Square Feet	
2	5'x10'	3"	4' 9" x 9' 7"	45.50	6,006	132.0	Lower deck top section Lower deck top section Upper deck top section Upper deck top section Upper deck lower section Upper deck lower section
1	6'x10'	1 1/2"	5' 4" x 9' 7"	51.64	2,840	55.5	
2	5'x10'	2"	4' 8" x 9' 7"	44.64	1,100	24.6	
1	6'x10'	2"	5' 8" x 9' 7"	54.22	1,320	24.3	
2	5'x10'	3"	4' 8" x 9' 7"	44.64	270	6.0	
1	4'x10'	6"	3' 8" x 9' 7"	35.06	108	3.0	
Bars							
35	1"		6'x10'	60.00			Covering the first 2-inch plate top section of screen.

General pitch of screen, 14° 0'

TABLE 2. PREPARATION OF COAL

Number of Combination	Track No. 1 Grades	Track No. 2 Grades	Track No. 3 Grades	Track No. 4 Grades
1	3" Lp.			1" Scgs.
2	2" Lp.		1 x 2" Nut	1" Scgs.
3	6" Lp.	2 x 6" Egg	1 x 2" Nut	1" Scgs.
4	14" Lp.			1 1/2" Scgs.
5	2" Lp.		1 1/2 x 2" Nut	1 1/2" Scgs.
6	6" Lp.	2 x 6" Egg	1 1/2 x 2" Nut	1 1/2" Scgs.
7	3" Lp.		1 1/2 x 3" Nut	1 1/2" Scgs.
8	6" Lp.	3 x 6" Egg	1 1/2 x 3" Nut	1 1/2" Scgs.
9	6" Lp.	1 1/2 x 6" Egg		1 1/2" Scgs.
10	2" Lp.			2" Scgs.
11	3" Lp.		2 x 3" Nut	2" Scgs.
12	6" Lp.	3 x 6" Egg	2 x 3" Nut	2" Scgs.
13	3" Lp.		3" Scgs.	
14	6" Lp.	3 x 6" Egg	3" Scgs.	
15	6" Lp.	6" M.R.		

TABLE 4. USE OF LEVER ON SCREENS

Lever Number

1	Door open, 4-inch coal to conveyer
2	Door open, 4-inch coal to screening chute track No. 4
3	Door open, 1 1/2-inch coal to screening chute track No. 4
4	Door open, 2-inch coal to solid plate, deck No. 3
5	Door open, 2-inch coal to nut chute, track No. 3
6	Door open, 3-inch coal to nut chute, track No. 3
7	Door open, 3-and 6-inch coal to egg chute, track No. 2
8	Door open, 2-inch coal to screening chute, track No. 1

TABLE 3. OPERATION OF SCREENS

To Make Combination Number	Screening	
	Open Doors by Lever No.*	Close Doors No.*
1	2	3-8-4-5-6-7
2	2-4-5	3-8-6-7
3	2-4-5-7	3-8-6
4	2-3	8-4-5-6-7
5	2-3-4-5	8-6-7
6	2-3-4-5-7	8-6
7	2-3-4-5-6	8-7
8	2-3-4-5-6-7	8
9	2-3-4-7	5-6-8
10	2-3-8	4-5-6-7
11	2-3-8-6	4-5-7
12	2-3-8-6-7	4-5
13	4-5-6	2-3-8-7
14	4-5-6-7	2-3-8
15	4-7	2-3-8-5-6

* See Table 4 of screen arrangement.

The tippie is a double A frame end hoist, 85 feet high to the sheaves, with a four-track shaker screen structure independent from the tippie.

The screens have three decks; are 10 feet wide; mounted on rollers, and are direct connected to two engines placed in the framing on each side. By a system of doors, butterflies, and plates, the coal

can be separated into 15 different combinations of sizes without the aid of a rescreening plant. Fig. 9 shows the arrangement of the screens and tracks, and the operation of the levers, doors, etc.

That the men in charge of the screens might acquaint themselves with its operation a blueprint is given them to which is attached typewritten instructions fully explaining just what doors to open or close and what levers to operate to make any required combination. A copy of the instructions is given in Tables 1, 2, 3, and 4.

The hoisting ropes are $1\frac{3}{8}$ -inch plough steel, and the cages are of the Bond type, self-dumping, and very massive and strong.

Air is forced into the mine by a slow-speed fan 20 feet in diameter. The stairway in the escapement shaft is steel from top to bottom with grate-bar steps so constructed that no water can accumulate on them.

When the plant is complete there will be a brick machine shop 60 ft. \times 100 ft., equipped with planer, lathe, trip hammers and other tools required in a first-class mine shop.

The surface tracks, which at present have a storage capacity of 80 loaded and 80 empty cars, are connected to the "Big Four" lines of the New York Central system, and are projected to eventually handle the output from the No. 3 shaft and a future shaft which will develop the No. 7 coal. Plans for the location of this shaft have been approved and adopted by the company.

The track arrangements at the shaft bottom shown in Fig. 5, provide for the coal all being caged from one side of the shaft, the empty cars being bumped off the cage by the loaded cars going on and then back switched by gravity to the empty tracks on either side the shaft.

Development began about the middle of January, 1911, and it is confidently expected that 1,500 tons per day will be the coal output at the close of the first year's work.

All of this coal has been handled by one Morgan-Gardner and two Goodman 6-ton gathering motors, no animals being used in the mine. The motors are equipped with both cable and crab, and each is gathering and delivering nearly 400 tons of coal to the shaft bottom, and, from the ease with which they are doing it, 500 tons each will not be too much to expect. When the development is extended sufficiently the gathering motors will deliver the coal to convenient partings and two 15-ton motors will haul it to the shaft bottom.

The projected workings as shown by Figs. 4 and 6 are on the panel system. Fig. 6 shows in detail the method employed. Triple entries are driven to the four points of the compass with cross-entries in pairs turned at right angles. Rooms 20 feet wide are turned with 40 feet centers and are driven from 300 and 350 feet; a barrier pillar 25 feet thick being left between the rooms from each entry. When the rooms in a panel are worked in to the limit it is expected to recover a greater part of the pillar coal by the retreating method.

The tracks on the main roads are laid with 50-pound steel rails, 20-pound steel rails being used in the rooms.

As the coal in this field is not always uniform in thickness the management has thoughtfully provided for such a contingency by making the pit cars very wide and very low, being 6 feet 2 inches

wide, 9 feet long, and 10 inches high. They have an 18-inch wheel, 27-inch wheel base, 42-inch track gauge, are equipped with gravity couplings, and will hold an average of $4\frac{1}{2}$ tons of coal.

All the coal will be undercut with electric chain breast machines, 12 of which are now at the mine, and the output is expected to reach over 4,000 tons per 8-hour shift.

The shaft sinking, fireproofing, etc., were contracted to and completed by Isaac Lindenmuth, Harrisburg, Ill.

采 采

Coal Washing at Lahausage

By Dav Allen Willey

A system of washing bituminous coal noted for its simplicity and economy has been placed in service to work on Alabama coal at the mining town of Lahausage in that state. By the method referred to, the coal, as it comes from the mines, is not only washed and separated but is crushed to the sizes desired for forge purposes.

The object of the plant is to supply coal of a suitable quality and size and free from impurities, for smithing and similar purposes.

The vein of coal mined, which is treated by washing, is located about 40 miles south of Chattanooga, near the town of Mento, and a few miles from a Southern Railway line, connected with the plant. Thus, the company has transportation facilities for marketing all the coal mined and washed. While the seam mined has an average thickness of but 24 inches, its quality makes it especially suitable for forge and steam fuel. It is slow burning coal, not too pasty, high in fixed carbon, low in ash and sulphur. The benefit of washing the coal is indicated by a comparative analysis made of the coal before and after being treated by water.

The washing reduces the ash in the slack from 14.17 per cent. to 9.43 per cent., effecting a reduction of 33.45 per cent., and the sulphur is reduced 19 per cent. or each 100 parts of sulphur in the unwashed becomes 81 parts in the

washed. Also 100 parts of ash in the unwashed becomes 66 $\frac{1}{2}$ parts in the washed product. The coal has a specific gravity of 1.31, and has been subjected to specific gravity solution test with the following result:

Unwashed coal contains 14.10 per cent. of ash and 1.20 per cent. of sulphur. Specific-gravity solution tests show that this unwashed coal contains 79 per cent. of material running 6.44 per cent. ash; 8.83 per cent. of material running 19.80 per cent. ash; and 11.38 per cent. of material running 52 per cent. ash.

The total capacity of the washer, which is located adjacent to the mine tippie, so that it is served by a chute, is 350 tons. Its equipment comprises one double New Century jig, one 75-horsepower engine, one 80-horsepower boiler, and one No. 2 Williams crushing mill. After the coal leaves the mining cars, it is delivered by a chute to a 20-foot Jeffrey flight conveyor; this conveys or delivers the run-of-mine product to a crusher where it is crushed to a size of $1\frac{1}{2}$ inches and under, and passing to a Link-Belt continuous-bucket elevator with 45-foot centers, it is delivered to a retention bin, from which it is fed directly by gravity to the jigs.

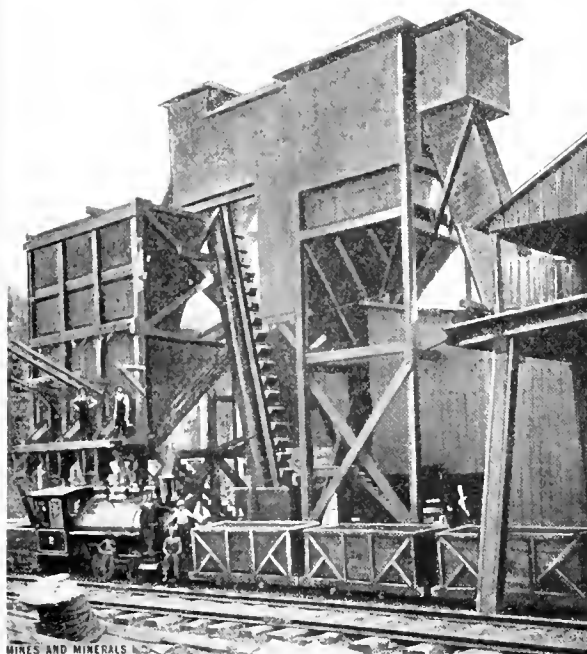

CONVEYORS FOR UNLOADING CARS AT LAHAUSAGE WASHERY

These jigs run at the rate of 145 revolutions per minute, each stroke requiring the equivalent of a 2½-inch stream of water, which is piped from a tank near the jigs. The capacity of the tank is 10,000 gallons. The washed coal leaves the jigs with the overflow, thence, by launder, to an elevator with perforated buckets for dewatering and delivering to a settling bin, the latter having a capacity of 300 tons. The elevators have a speed of 12½ revolutions per minute.

The coal-hauling and washing machinery is driven by a drive of three strands of 1-inch manila transmission rope, traveling 1,884 feet per minute. The engine speed is 150 revolutions per minute. The crusher is driven by a 12-inch double-leather belt with cemented connections, from a countershaft with 20-foot belt centers. The crusher has a speed of 1,200 revolutions per minute, with 20-inch pulley, and the latter a speed of 500 revolutions per minute and a 48-inch wood split pulley; the crusher belt travels at a speed of 6,200 feet per minute. This countershaft is driven by a 12-inch Gandy belt from a 72-inch pulley on the engine to a 26-inch pulley on the countershaft.

The refuse from the jigs is handled by unique automatic slate valves and is delivered to the bottom of the jig tanks, thence by bucket elevator to the launder, where it is loaded in railroad cars and used for filling trestles.

The coal is shipped from the washer by means of an inclined cable railroad 2,000 feet long, connecting with a spur of the Chattanooga Southern Railway. The total cost of building this connection and equipping it was \$57,454, while the washing plant, ready for service, cost \$10,000 with complete mechanical equipment.

The originator of the plan and director of construction was A. W. Evans, superintendent of the Lookout Fuel Co., which owns the mine.

采 采

Trade Notices

New Fans.—J. C. Stine, of Tyrone, Pa., writes that his company has received an order from South Africa for two fans. Recently he has received orders from Penn-Mary Coal Co., Deep Vein Coal Co., Ind., and from Premier Pocahontas Colliery Co., Premier, W. Va., for disk fans.

Electric Lighting Improvements.—The Western Electric Co. is introducing what it terms Holophane steel reflectors for shop work. Holophane reflectors with Mazda or tungsten lamps produce, it is said, a working illumination of sunshine efficiency. When properly placed, all shadows are eliminated and there is no eye-tiring glare.

A New World's Record for Coal Hoisting.—The Superior Coal Co.'s No. 3 mine, at Gillespie, Ill., broke its own and the world's record for a single day's hoisting of coal on December 22, hoisting 4,468 tons and 1,300 pounds of coal in 8 hours from a vertical depth of 392 feet. This record was made by a pair of 24×36 hoisting engines built by the Litchfield Foundry and Machine Co., of Litchfield, Ill. These engines are of this company's standard design and have been in service more than 7 years, during which time they have gradually raised the average output from 2,000 tons a day to a present average of over 4,000 tons. Both the Superior Coal Co. and the Litchfield Foundry and Machine Co. are to be congratulated on this consistent performance.

New Office.—On January 1, the Ridgway Dynamo and Engine Co., of Ridgway, Pa., opened a new office at Room 1417, Oliver Building, Pittsburg, Pa. The local manager is Mr. J. F. Rodgers, a native of Pittsburg, who enjoys a wide acquaintance among mine, mill, and manufacturing interests.

Double-Crimped Mining Screens.—While ordinary punched mining screens serve their purpose, there has been placed upon the market a double-crimped screen known as "The Perfect," and manufactured by the Ludlow-Saylor Wire Co., St. Louis, Mo. The manufacturers claim a number of valuable features in their booklet. Among them are these: The wire used is of such unusual toughness and so true to gauge that a long life is assured,

together with much extra screening surface. The double crimping makes the mesh accurate, prevents the spreading of the mesh if rock splinters become wedged, and gives a uniform distribution of strain. A very striking catalog describing the various kinds of screens made, together with sizes and prices, has been issued and will be sent on request.

Electric Hoists.—Bulletin No. 200, recently issued by the Ottumwa Iron Works, illustrates and concisely describes an attractive series of designs for electric motors. It is seldom that one sees all the necessary information concerning certain types of machinery given in such a concise and simple manner. On the first three pages is given a general description of Ottumwa electric hoists and a page is devoted to a series of questions to be answered when making inquiries regarding particular installations. The balance of the bulletin is devoted to illustrating and giving specifications for the various types of hoists made by them. It will be sent to any interested mine manager or superintendent who will write to Ottumwa Iron Works, Ottumwa, Iowa.

The Trenton Iron Co. announces that Harry G. Stoddard has resigned as president of that company to become associated with the Wyman & Gordon Co., drop forging manufacturers., Worcester, Mass. James W. Smith, formerly superintendent, has been elected manager of the company, and William E. Corne, formerly New York sales manager, has been made general sales agent. The general selling offices of the company will be located in the Hudson Terminal Building, 30 Church Street, New York City, N. Y.

Hammer Drills.—A 12-page pamphlet issued by Ingersoll-Rand Co., 11 Broadway, New York City, describes their "MC-22" telescope feed hammer drill. This drill is of the "valveless" type, in which the piston itself performs the valve functions by covering or uncovering ports, which control its forward-and-back movement. This tool is intended for stoping, raising, and, to a limited extent, drifting. It is not recommended for steady work in holes at less than 20 degrees from the horizontal, because of the difficulty of cleaning such holes. The telescope feed is designated by the company as the "reversed feed;" the inner, or piston, tube is attached to the drill, and the outer, or cylinder, tube runs out under pressure. The advantage of this arrangement is that the hose is stationary, not turning with the drill, and the tool may be used on a tripod or column by clamping the outer feed cylinder to the mounting.

Presentation of Testimonial.—When the National Association of Steam Engineers held their convention in Cincinnati last September, they were entertained by the Lunkenheimer Company of that city and given a river ride, picnic, barbecue, and burgoo. On December 11, at a banquet given by the company at the Cincinnati Business Men's Club, F. W. Ravin, national secretary of the N. A. S. E., presented to the company an embossed testimonial on behalf of the association. David C. Jones, secretary of the Lunkenheimer Company, acted as toastmaster, and responded to the presentation speech made by Mr. Raven. Other speakers of the evening were J. Kerley, chairman of the convention committee; Messrs. Delaney, Pratt, Schuler, Wilson, Boyer, Wermel, Thompson, Knopp, and Haberkoppee, all members of the local convention committee, and Mr. H. E. Poole, of the company. This is only the second time in the history of the N. A. S. E. that a testimonial was presented, and the company naturally feels highly honored and gratified.

"The Proof of the Motor."—This practically covers the idea of a 20-page booklet issued by the George D. Whitcomb Company, of Rochelle, Ill. The Whitcomb Company has developed and perfected a really wonderful gasoline motor for mine haulage. Among its many advantages is the fact that it can operate in extremely narrow passages and is so flexible as to always follow the track, no matter what the curve or how uneven the track may be. The motor may be operated from either end and is designed to protect all vulnerable parts from dirt and mud in the mines. The booklet referred to gives a series of letters showing the difference in cost between the operation of the Whitcomb gasoline motor and the use of mules for the same work. The mules cost about twice as much. All further details may be had from the company.

Cross Mountain Mine Explosion

The Mine, Its Ventilation Plan, the Effects of the Explosion, and the Recovery Work

On Saturday, December 9, 1911, at 7:20 A. M., an explosion occurred in Cross Mountain No. 1 mine, near Briceville, Tenn., in which 84 men lost their lives.

Cross Mountain, from which the mine is named, is one of the high peaks of the Cumberland Mountains, that attains an elevation of 3,500 feet above sea level; the elevation of the Cross Mountain coal bed, however, is 1005 feet above sea level at the place where the Cross Mountain mine drifts penetrate the mountain on Slate Stone Run. Briceville is reached from Coal Creek, on the Southern, and the Louisville and Nashville railways, by stage, and Cross Mountain mine, about $1\frac{1}{2}$ miles from Briceville, is reached by walking the railroad track. Here the Knoxville Iron Co. leases 2,900 acres of the property in which the coal bed is found, from the Coal Creek Mining and Mfg. Co. Cross Mountain coal bed outcrops about 40 feet above Slate Stone Run in a gulch so narrow the tippie trestle spans it, as shown in Fig 1, thus making it possible for the one tippie to answer for both No. 1 and No. 2 mines.

From the drift mouth of No. 1 mine, in which the explosion took place, there is a gradual rise of the coal bed on a 2-per-cent. grade for a distance of 3,100 feet, after which there is a gradual descent on a 2-per-cent. grade to the ends of the entries, which have a length of about 8,400 feet. Owing to there being little cover and that being weak rock and wash dirt, the cross-entries up to the anticline have been worked only slightly, the main workings being beyond the crest. Cross Mountain No. 1 mine was opened in 1888, and because it has been worked continuously it is an extensive mine with long cross-entries extending right and left from the two main entries. At first the operation was ventilated by an air-shaft A, Fig. 2, sunk about 100 feet from the surface to the crest of the anticline inside. This arrangement was capable of furnishing 10,000 cubic feet of air per minute by natural ventilation. In due time natural ventilation was aided by a furnace, which was abandoned in 1903 and replaced by an electrical-driven 7-foot Johnson exhaust fan erected inside at the bottom of the shaft. From air measurements furnished by Superintendent Lynch, the fan when running at 300 revolutions per minute, exhausted 50,000 cubic feet of air per minute, a quantity sufficient according to the German standard for ventilation based on the number of tons of coal mined, or 1.5 cubic meters, equal 50 cubic feet, of air per ton, and the Tennessee standard of 100 cubic feet per minute for each man and 500 cubic feet per minute for each animal in the mine, there being 125 men and 7 mules working as a rule. An analysis of the Cross Mountain coal bed furnished by Superintendent Lynch is as follows: Fixed carbon, 55.55 per cent.; volatile matter, 40 per cent.; ash, 3.10 per cent.; moisture, 1.35. Total, 100 per cent. Sulphur, .63 per cent.

Data furnished by the Knoxville Iron Co., which uses approximately 100 tons of this coal daily in the rolling mill, is to the effect that each ton produces 10,000 cubic feet of 16-candlepower gas. While there are a number of coal beds in the Cross Mountain

district, only three of them are said to be more than 36 inches thick, but the average thickness of the Cross Mountain or principal bed is given as 46 inches.

As stated, the covering to the crest of the anticline is poor, but beyond that there is 25 feet of hard slate above the coal, which forms an excellent roof, while below the coal there is about $2\frac{1}{2}$ feet of fireclay that is occasionally given to creeping. The mine is laid out systematically and worked on the double-entry system. Entries are driven $9\frac{1}{2}$ to 10 feet wide on 60-foot centers, the haulage roads being brushed. Breakthroughs are driven at intervals as prescribed by law, those between the main entries being closed by 9-inch brick walls, and those between the cross-entries by stone, with the exception of two or three close to working faces where temporary board air stoppings are adopted. The distance between two pairs of cross-entries on the main entries is 330 feet, and from one entry of each pair, double rooms 40 feet wide are turned on 100-foot centers, advantage being taken of the 2-per-cent. rise for haulage and drainage purposes. Mules and motors gather the loaded cars, which are hauled from the mine in trips varying from 25 to 40 cars each, by Goodman electric locomotives.

Fresh air entered the mine at the two drift mouths and traveled through both the entry and air-course, there being no brattices between these two parallel headings, to the upcast shaft, a distance of 3,000 feet. On account of the tender top prevailing under the low foot-hills referred to above, the roof had fallen out up to a small

seam of coal some 15 feet above the main seam. This gave the haulage entry and air-course an approximate area of 150 square feet each, and the brattices being out, the passing of motor trips did not tend to baffle the air, but allowed an uninterrupted flow of fresh air to reach the anticline at the shaft; here the double intake ceased, but as a good slate roof set in at this point the main heading was widened out for side-track purposes, and continued on down a



FIG. 1. TIPPLE AT CROSS MOUNTAIN

2-per-cent. grade to the head of the main entries, at double-track width, giving an average area of 100 square feet all the way. The full volume of 50,000 cubic feet of air passed down this 2-per-cent. grade to the head of the main and was there split, going each way to right and left, as the men were about equally divided, 50 to 60 on each side. Double-entry mining being followed, the cross or butt entries were turned each 330 feet, and extended to the property line on each side about 3,000 feet. The air-course for a pair of cross-entries was on the inside, was driven 16 feet wide and no top brushed. The haulage entry paralleling the air-course was a gob entry, 16 feet wide, but the roof was brushed to furnish mule and motor height.

The rooms on 100-foot centers on the upper side of the entry, allow 40-foot double-track rooms with a room neck for each track; the cross-entries are 30 feet apart and breakthroughs between them are driven every 60 feet. After the air split at the head of the main-haulage entry it passed up the butt entry air-course and down the haulage to the main-entry air-course and out to the next butt, up this and back as before, but this was only done on the new butt entries. As soon as a series of rooms is mined full length, about every fourth one is driven through to the air-course of the next pair of entries. This allows the air to short-circuit up near the head instead of going clear back to the main entry air-course; as the air naturally would seek the shortest cut,

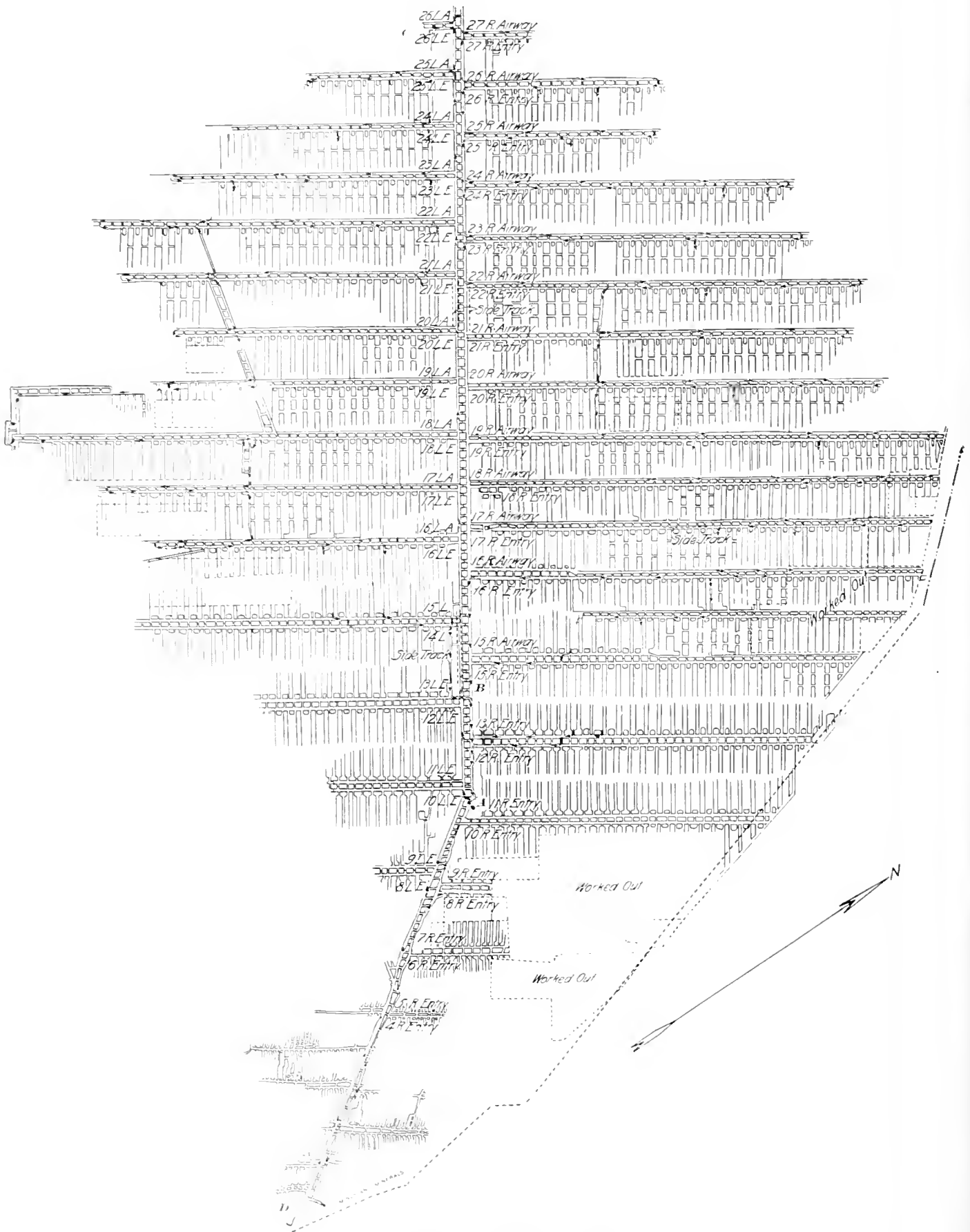

FIG. 2. MAP OF CROSS MOUNTAIN MINE
A, Upcast Shaft; B, Overcast; C, Last Left Entry; D, Emergency Fan.

it may be seen that by keeping these rooms cut through near the head of the butts, the air was kept well up to the face of the workings; so true is this that there was very little velocity on the long butts out near the main, and the anemometer showed 8,000 to 10,000 cubic feet at the last breakthrough.

On the right side, after passing around the faces of some 10 pairs of butt entries, the air found its way through the old rooms to the shaft *A*, located on the right at the top of the antiline. On the left it followed the same routine, except that after ventilating the live workings it passed through the old rooms and an overcast *B* over the main entry between 14 and 15 cross-entries to the shaft. As the right side had the shortest pull to the upcast shaft it tended to rob the left side, and this was overcome by placing a regulator near the head of the main. After reaching the top of the hill the large volume of fresh cool air sought the lower levels down the 2-per-cent. grade 5,000 feet to the head of the mains naturally and quickly; passing around the faces it began to warm up and expand, now going back up hill as naturally as it went down before, rushing out the upcast shaft 100 feet in depth. When one considers the long distance this air traveled, 8,000 feet on the mains and out the butts 3,000 feet, with their rough gob sides, and only a 7-foot disk fan in a thin vein, the splendid ventilation has few parallels in this country; the answer is probably found by reason of the unusually large intake and the fact of the fan being located at the upcast shaft, which alone has a motive power sufficient to produce 10,000 cubic feet of natural ventilation. It was suggested by some that the fan set up after the explosion should have been made an exhaust fan; to have put it at the top of the upcast shaft would have required 2 days work, as there were no buildings or fan house there of any kind, and

the top of the shaft is a half mile back in the foot-hills where there was no power. To have made it exhaust at the drift mouth, it is very doubtful, with a fan of this kind, if it could have overcome the natural motive column at the upcast shaft, but granting that it would have caused some vacuum, the air that went down the shaft would have diffused itself out through the old works on the right, and since the main parallel air-course had not been used as a return for years, it being a manway with doors between each pair of butts, the air going around the head of the butts, as explained above, no air would have got through it over on the left side of the mine at all; but by placing a pressure fan at the drift mouth, as was done, the air flowed in just as it did before the explosion and the shaft aided it as before; moreover the mine workers all knew how the air traveled and to have reversed it upon them would have meant death to all. Some have suggested that the Thistle mine, being an exhaust, acted as a booster to the Cross Mountain mine and served to pull the afterdamp on to the men. This is not true, because the connection between these mines was mainly back at 10, 11, 12, 13, and 14 right entries, which had not been cut through at all, except a small hole serving to indicate that the boundary line had been reached, and these had been bratticed off. The territory had long since been robbed and caved,

and as the Thistle fan was located 7,000 feet away from the afterdamp, and with no direct connection, it could not possibly have overcome the effects of the upcast shaft close by.

In point of violence the explosion was not near so great as that at the experimental Brucetown mine which the government experts say was caused by dry dust that would pass a screen having 10,000 holes to the square inch, for no report was heard at the drift mouth; nothing was projected from the drift mouth with violence and the portals were not injured. The concussion was, however, sufficiently great inside to blow down the 9 inches thick brick air stoppings, with the exception of two or three nearest the faces of the main entries, and a few of the rock stoppings on the cross-entries nearest to the main entries.

Although gas had been detected at times, the mine was not gaseous and open lights were used, but owing to the Fraterville mine explosion which occurred in a nearby mine 9½ years ago, R. A. Shifflett, State Mine Inspector, ordered the Knoxville Iron Co. to employ a fire boss who should inspect the workings thoroughly within 3 hours before the men entered the mine in the morning. This was done during the night preceding the explosion, the fire

boss coming out at 1:30 A. M. and reporting everything in order.

District Mine Inspector Joseph Richards, of Tennessee, after an examination ending October 31, 1911, pronounced the mine in good condition; it must be assumed therefore that, so far as man's means of observations go, the mine was in good condition and it was a very methodically worked double-entry mine.

On the morning of the explosion two men who were advancing the heading marked *C*, the last cross-entry on the left, entered the mine at 5:30 A. M., in order to break coal for the day's run, they having been cleaned

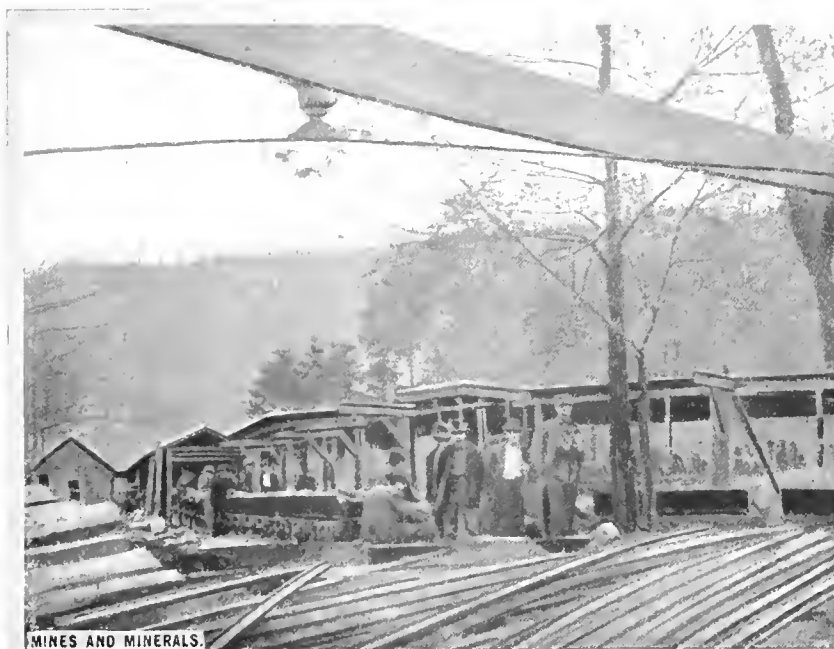

FIG. 3. CROSS MOUNTAIN MINE SHEDS

up the previous day. It is customary at this mine on account of the distance the men have to walk from the drift mouth to their working places, to carry them in on cars at a stated time in the morning. The men having all been hauled into the mine, there was nothing but the mules and drivers that could have stirred up any dust, the trip having gone in on the main entry, half of which was continually moist from the effects of running water escaping from the left side of the mine, and the other half sprinkled by the water boxes the day before. The condition in the airway was somewhat different, as only the mules and drivers traveled this, cutting up the fireclay bottom, making a shale dust that was not explosive and was not affected by the flame, and it was the only dusty part on either the main haulway or the airway, there being no coal dust in this particular part of the mine. In so far as dust causing the explosion is concerned, the chemical composition and the physical structure of the coal are factors which had considerable bearing on the violence of the explosion, and the extent of the damage so far as the loss of life is concerned. By an examination of the analysis, it will be seen that this is a gas coal approximating cannel coal in composition; consequently, while classed as a dusty mine, the coal does not readily air slack and become impalpable powder that will explode after the manner of the dust

used at the Brucetown mine explosion, or the dust from friable coals that air slack and lose their moisture until they become dust. This statement does not preclude the fact that Cross Mountain coal on roadbeds may become fine by attrition from car wheels, mules, etc., to a limited extent, and that such dust might be rendered less dangerous if the roadbeds were given an occasional dressing of surface dirt. Again the physical structure combined with the chemical composition of the Cross Mountain coal is such that water sprinkling or saturating the ingoing air with steam would have but little effect on it, nevertheless the inspector ordered that the roadbeds should be watered and sprinkling cars were run over the entries at stated intervals.

Cannel coals and some gas coals high in volatile matter can be set on fire with a match, and all that was necessary at this mine to set fire to the dust was a propagating flame which could have been furnished by a blown-out shot or by the explosion of a can of powder. Assuming that the statements of the men who escaped are reliable, and taking into consideration that the explosive wave passed down both main entries, that the brick air stoppings were destroyed with a few exceptions near the main entry headings, that few bodies off the main entries were burned, that the greatest violence was evident at about the middle length of the main entries to 26 left, that some coke was found on but one edge of some timbers and both sides of others, it follows as a natural sequence that the explosion origi-

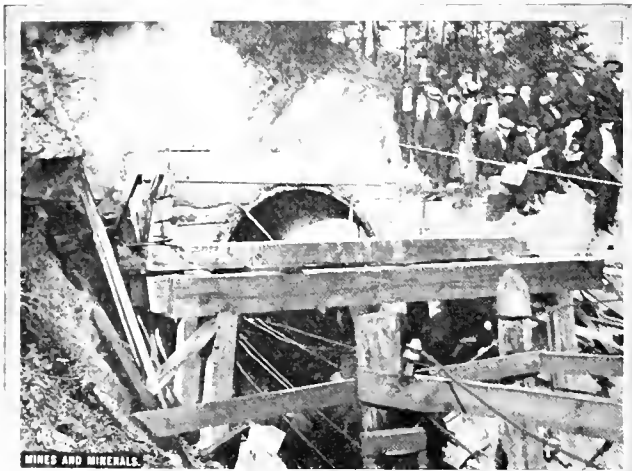

FIG. 4. EMERGENCY FAN AFTER ACCIDENT

nated near the heading of the main entries, traveled comparatively slowly so that the heat of the propagating flame distilled gas from the fine coal drawn into the vacuum behind the concussion wave, and setting fire to it filled the entries with flame. It has been well established that dust explosions increase in violence as they travel, provided there is fuel to feed them; naturally then the air stoppings nearest to the cause of the explosion would not be blown down, as the intensity of the concussion wave would not be so great at this point.

Milton Henderson, one of the survivors, stated that, "he was on entry No. 18 left when he heard the explosion, and by jumping into a room dodged fire"; "a great rush of air and smoke followed and then came the afterdamp, which smelled like powder smoke."

Arthur Scott, another survivor, stated that, "he was on entry No. 18 left and that smoke followed the explosion with very little coal dust." While all the men saved were in the left entries at the time of the explosion, H. A. Irish, boss of the entry, who was near the entrance to 18 left, was thrown back into the cross-entry several feet and injured so badly he insisted upon the others leaving him and saving themselves. His son who went to his rescue was badly burned in dragging his father from the fire zone near the mouth of the entry, and these were the only two men of a party of eight that were badly burned. Comparing the force of this explosion with the Brucetown affair which wrecked the mine and

threw a mine car, standing outside the mine, a distance said to be 200 feet, it will be seen to have been relatively slight. Another feature worthy of note is that the concussion traveled alternately faster in one entry than in the other, for the brick stoppings were thrown for a while in one direction and then in the other.

As soon as word of the explosion was sent abroad, mine foremen and miners from neighboring operations rushed to the scene, and others from distant mines as well, to offer their services. To these men President Stephenson wishes through MINES AND MINERALS to extend his heartfelt thanks for their kindly consideration of the unfortunate men in the mine and their helpfulness in the time of trouble. MINES AND MINERALS joins with him in complimenting these men on their bravery and on the untiring zeal with which they prosecuted recovery work under most exasperating conditions without thought of compensation. At this time union men and non-union men welded together by the common impulse ignored their differences of opinion and worked side by side, frequently risking their own lives in their endeavors to save those shut in the mine by deadly afterdamp.

The first rescue party headed by Supt. P. J. Lynch and George Bulmer, mine foreman, entered the mine almost immediately, and in 30 minutes after the explosion reached the air-shaft, 3,000 feet from the mouth of the mine. At this point, being stopped by bad air and heat, they turned their attentions to restoring the ventilation. With this end in view brush fires were started about the top of the shaft to induce natural ventilation and board air stops were built where the brick ones were blown down, thus advancing in from the air-shaft slowly. The first bodies were found in the main entry.

Soon after the accident President T. I. Stephenson was telephoned and he immediately chartered a special train to leave Knoxville at 11 A. M. with a rescue party. He then went to the Knoxville Station of the Federal Bureau of Mines for helmet men. E. B. Sutton, in charge of the Knoxville Station, reached Briceville about 1:30 P. M., December 9, and was accompanied by Assistant State Mine Inspector Joseph Richards. Mine Rescue Car No. 7 in charge of William Burke as foreman, and John Ferrell as first-aid miner, reached Briceville about 5:30 P. M., December 9, coming from Warren, Ky. Geo. E. Sylvester and W. T. Richards reached the mine on the afternoon of the 9th, and Mr. Rose, Mr. Sylvester's other assistant, arrived on Sunday, the 10th, all of the state officials having given the matter immediate attention upon having been notified. President Stephenson in the meantime having heard of a disk fan being at the Black Diamond mine got in communication with the owners and the Southern Railway officials, so that by 2 A. M. Sunday, the 10th, it was in running order on the old return airway near the tippie. This fan, shown in Fig. 4, was used to force air into the mine, which necessitated that a door be placed at the haulage-road entrance to the mine; the air, however, was continued in the direction in which it had circulated previous to the explosion.

A. R. Brown, foreman in charge of the Birmingham, Ala., Station, reached Briceville, Sunday morning, December 10; Dr. J. A. Holmes, Director of the Bureau of Mines, arrived Sunday evening. Mr. Sutton had reached a point on the main entry between the 14th and 15th right entries at the time car No. 7 arrived. About 1 A. M., Sunday, the 10th, some of the men had reached a point opposite the 23d right; at 11:30 P. M., Sunday, the rescue men had reached the inside end of No. 3 side track.

The face of the main entry was reached about 2 A. M. Monday, the 11th. About 6 P. M. Monday, Brown and Ferrell and Richards, when going into the mine and passing the mouth of the 18th left, heard some one knocking on the temporary air stopping. The party assisted by the driver, procured picks, tore open the stopping and found Milton Henderson, Wm. Henderson, and Irbin Smith, inside of the stopping. The two Hendersons, father and son, were in good condition, but Smith had been badly burned. These men informed the rescue party that there were two men still inside the mine barricaded on the haulway between 16th and 17th left who were unable to come out with the other party, one of them, Irish,

being burned. J. W. Paul, who was in charge of the rescue work, and was at this time on the main entry at the mouth of 22d right, was informed of the living men being in the mine, and made arrangements to bring them out at once. The party composed of Redunbush, of Car No. 6, which had arrived an hour or two previous, and Ferrell, of Car No. 7, and John Richards, of Rockwood, and Brown, of Birmingham, went into the 18th left and brought out Dora Irish, who had been badly burned about the hands and face, and Erwin Scott, who was uninjured. These men had successfully barricaded themselves and by the use of the gob stopping made tight by hay from the mule stable, had been able to keep away from the afterdamp. Irish was bandaged up and then the two remaining survivors were sent out of the mine, between 9 and 10 P. M. Monday. Tuesday morning at 6 A. M., a fire was discovered to be burning in a breakthrough in the 17th left. This was played on with fire extinguishers, and afterwards loaded out by the mine foreman, Geo. Bulmer and his men. A fire was discovered Wednesday night in the 18th left. This was a gob fire and was extinguished by loading out the gob. On Thursday a large fire was found in the 17th right in a breakthrough.

Although the first helmet men from the Bureau of Mines arrived Saturday afternoon and the first rescue car Saturday night, nothing of moment was accomplished by the government experts until after the fan had been started Sunday night, when Dr. J. A. Holmes arrived and took charge of the inside work, while President Stephenson and his assistants maintained an efficient rescue organization outside, who went in the mine to work in short shifts of 2 hours. By Tuesday morning 32 bodies were recovered and 5 men escaped from the left entry alive. The fire on No. 17 left was discovered while rescuers were looking for two men who were known to be groping about that part of the mine. This fire delayed rescue work seriously, for when it was presumably out it would start again. Water was taken into the mine in barrels to help extinguish it, and finally the heroic measure of shoveling the burning material out was adopted. While fire fighting was in progress the rescue men were compelled to remain idle and this rather discouraged them. Every now and then some one would be overcome by afterdamp; however, none of the rescuers lost their lives, as their inanimated bodies were recovered quickly and taken outside or the pulmotors were quickly applied. From Tuesday morning to Wednesday noon when the Birmingham helmet men arrived, but three bodies had been recovered, although several were located by helmet men. The Birmingham corps being fresh and experienced men were able to work to better advantage than those crews first on the ground, who by this time were exhausted, consequently with their advent under the direction of Doctor Groves matters began to assume a more energetic appearance. Although the end of the main air-course was reached by 2 A. M. Monday morning, the right cross-entries, which up to this time cleared slowly of afterdamp, were not explored until Wednesday night. Could the disk fan have been used as an exhauster, and the shaft closed, which under the conditions would have required additional work, the cool air would have had a straight away course down the main haulway; diffusion would then have been quicker; the bad air in the entries would have been diluted and probably more lives would have been saved. This is evident from the fact that the fire discovered Tuesday on No. 17 left should not have prevented the rescuers from working until Wednesday night on the right entries and is further borne out by finding the Miller party of five at the end of No. 22 right, where they had gone to escape the afterdamp. These men were evidently overcome a short time before, while they slept, for when found their bodies were warm and their coats were under their heads for pillows.

Investigations of accidents of this description, yielding knowledge as to their cause and what remedies should be applied for their prevention, lose their value if their results are not published to the fraternity at the earliest possible moment. Therefore, if the investigations to be made by the United States Bureau of Mines and the Mining Department of Tennessee are to be of real value, the results of such investigations should be given the mining public as soon as they are determined, and not to be held up for months

until the government or state printers get time to issue the reports. In connection with what follows in regard to the explosion it is to be understood that the cause is not definitely known and probably never will be, and whatever is stated in this report is derived from inquiries made with a view to attempting to establish a plausible theory.

There is nothing of a scientific nature to be learned from a mere explosion of gas, dust, or a combination of gas and dust. What the coal-mining public desires to know is the cause of the primal explosion; the safeguards taken by the mine officials to avoid the explosion; what safeguards were neglected; the detailed description of the rescue work, and such other matters as have a practical bearing on the subject of mine explosions.

The conclusions to draw from this explosion are in some particulars different from those that have previously appeared in *MINES AND MINERALS* after an explosion. (1) The State Mine Inspector of Tennessee should not have allowed the fan to have been placed inside the mine where it was sure to be put out of commission in case of an explosion. (2) Black powder should not be used in any bituminous coal mine, and as a precaution, although not an infallible preventive, the use of permissible explosives should be insisted upon by state inspectors. (3) Sprinkling the mine or humidifying the air entering the mine with steam is not always a preventive to coal-dust explosions; but on haulage roads where highly bituminous coal, not easily air slacked, is mined, dirt will be found efficacious. (4) The speed of the concussion wave will be stopped where there

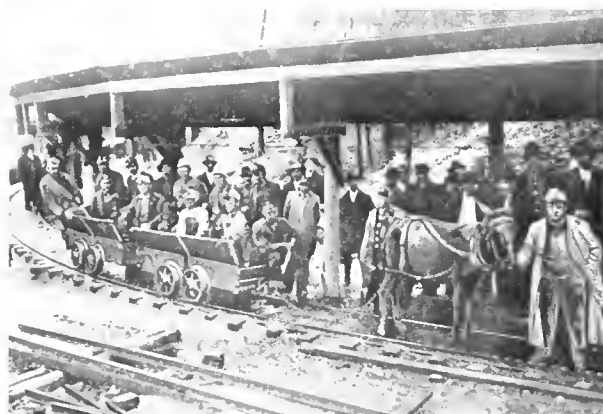

FIG. 5. RESCUERS GOING INTO MINE

is a chance for its expansion, and if conditions are favorable the propagating flame following will be extinguished by cool air, free from coal dust, rushing into the vacuum.

Reports of mine explosions that have appeared in *MINES AND MINERALS* for the past 2 years have demonstrated that where there has been a chance for the concussion wave to expand or where there has been standing water to cool the flame and not allow dust to be drawn into the vacuum for the flame to feed upon, the propagating flame has ceased. As stated, the propagating flame in Cross Mountain mine traveled both main entries with unequal speeds, due perhaps to the turnouts slowing them up first on one entry and then on the other. It is therefore the firm belief of the writer that had the turnouts been surfaced with dirt the flames would not have crossed over them, for no coal dust would have been drawn into the vacuum to feed them.

There seems to be no reason for attaching blame to the management of the Cross Mountain mine for this accident. All the instructions ordered by the state mine inspectors were complied with, and the calamity was more appalling and surprising to the owners than probably to any one else. To the management of Cross Mountain mine there is an individual loss not to be reckoned in money but based on friendships that originated at the time of serious labor troubles when those miners now dead remained loyal to the company under exasperating and trying circumstances.

Purchasing Locomotive Fuel

Qualities Necessary for a Good Locomotive Coal. Other Conditions Determining Values

The following is abstracted from a paper by R. D. Quinckel, E. M.,* read at the Mining Institute of Kentucky, and entitled "A Few Factors Entering Into the Purchase of Locomotive Fuel Coal":

The coal problem is one of the greatest that confronts the railroads of today. When it is considered that 13 per cent. of the operating expenses of the railroads in the United States is spent for fuel, or, putting it in another form, 8 or 9 per cent. of the gross earnings of America's railways is spent for coal, it is seen why, today, we are hearing so much about fuel economy. The locomotives of this country burn about one-fourth of the coal production of the United States and one-tenth of the production of the world. Therefore, as coal is of such importance from an operating standpoint, it can be understood why the railroads have formed special departments for the purchase and supervision of such a necessary adjunct to their operation.

From an operating standpoint, the most desirable coals, other things being equal, are those which cost the least f. o. b. engine tenders.

From the traffic department's standpoint, the most desirable coals are those which give the greatest earnings from freight and passenger business. Taking into consideration the interests of the railroad and the coal company located on its line, the most desirable coals are those which give the greatest net earnings to the respective companies.

Frequently, it is impossible for a railroad to use a certain coal, owing to the fact that it will not burn under the same conditions as the other coals which are in use. While the rejected coal may be of excellent character so far as heating value, ash, and sulphur are concerned, yet the relation of its fixed carbon and volatile matter may require special draft arrangements for its proper and economical combustion. The draft arrangement of a locomotive cannot be changed to suit the particular fuel, but must be adjusted so that the engine will give a maximum steam pressure for all the coals in use on a division. Again, certain types of locomotives will demand certain kinds of fuel. One type will show greater economy with gas coal than with splint; another type will show the reverse.

Very frequently operators say that their coal is better by analysis and British thermal unit determination than the grade of coal being used by the railroad, and they are at a loss to understand why their coal is not considered. The reason is, their coal will not burn under the same conditions as the coals in use.

From an efficiency standpoint, a railroad would be operating under the best conditions if it used one kind of coal over the entire road. On a large railroad this is impracticable, as one mine or group of mines could not probably supply the necessary quantity, and also because the haul necessary to deliver the coal would be unprofitable to the railroad company.

One of the worst practices in vogue today is the placing of a variety of coals on one division. This practice is bad on account of the personal element in firing entering into the actual combustion of the fuel. The locomotive fireman responsible for the proper use of the fuel, and who has become accustomed to using one or two kinds of coal, will probably have trouble in keeping up steam if forced to use fuel with which he is not familiar. While the third kind of fuel may be excellent, yet the fireman will be unable to produce results, as he will be unable to fire it properly. For instance, the coals on the C. N. O. & T. P., from the first mine, located at Alpine, Ky., to the Glen Mary mines, located at Glen Mary, Tenn., can be raked or sliced without much damage to the fire; yet coals from the Harriman & Northeastern mines will, if hooked, give a great deal of trouble from clinkers, but if let alone will give excellent results, and a fireman will hold 200 pounds of

* Fuel Agent, Queen and Crescent Route.

steam from Oakdale, Tenn., to Chattanooga, Tenn., and never use the slice bar.

Another thing to be considered in letting a coal contract is the standing and responsibility of the concern bidding, its ability to fill contracts, or several contracts of any magnitude. Sometimes a coal company will over contract its tonnage, and this the fuel agent must guard against, as such a firm is not to be depended upon to furnish contract tonnage when coal is at a premium.

Were it not for railroad contracts, the mines of this state, as well as others, would not be able to exist, at least in the numbers that they do now. While it is true that railroads demand cheaper coal than others, yet a mine having a railroad contract is assured of 12 months business and does not have any difficulty in placing this tonnage. Further, it has practically no outside expenses, such as traveling and hotel bills. Considering everything, operators can well afford to sell coal a little cheaper to railroads than to industrial plants.

Conditions on other roads may vary, but it is true that if it were not for the Queen & Crescent Railroad taking their steam coal, the mines on that road would not be able to exist. While their railroad contracts do not give them a great profit, yet, it is in line with prices existing in other localities, and they are in a position to make and sell domestic coal at a good profit when the market warrants it. If the domestic market is off, they still have their railroad contracts, from which they can keep their organization intact and their mines in good shape and sell their product for a fair price.

The coal furnished on a railroad contract, first, must be such as to enable the firemen to make sufficient steam to go over the road on schedule time. To determine whether a coal is of a quality to do this, it must be actually tested on a locomotive. Proximate analysis and British thermal unit determinations may give a fair idea of a coal, but will not show whether the coal will be absolutely satisfactory. The proximate analysis will show the moisture, ash, and sulphur in a coal, and such an analysis is valuable for those reasons. Moisture, of course, enters into the actual weight of the coal on the purchase price, and as ash is the refuse from combustion, a company is not going to buy more of this than it can help. Ash is also expensive to handle, both on the road and at terminals. Sulphur is determined because, while it is combustible and will burn with an intense heat, yet it will, if there are any other fusible substances present, clinker and corrode grate fingers, fireboxes, and boiler tubes.

The other impurities which should determine the purchase price of locomotive coal are bone, slate, laminated coal, and "rash." While these impurities are, as a rule, largely removed, nevertheless they may occur in quantities sufficient to affect the value of the product. Slate and bone coal form clinkers, while "rash" and laminated coal cause the firebox to fill up. Any large percentage of iron and silicious material will form what is known as "honey comb," a ferrous silicate, which collects in the boiler tubes and not only corrodes the boiler tubes, but seriously interferes with the draft.

A railroad locomotive is an expensive piece of machinery; it must be kept in first-class condition, and since a firebox temperature of about 2,300° F. is absolutely necessary for its proper operation, the various impurities that occur with coal and injure the boiler tend to increase the operating expenses besides interfere with the proper combustion of its fuel; therefore, the fuel used should be free from impurities.

There was a time when some operators paid little attention to the preparation of their locomotive fuel, taking the stand that a thorough preparation was unnecessary, as the railroad would take it any way. That feeling should be banished, as the railroads are not going to purchase poorly prepared fuel.

Another matter to be taken into consideration is the degree of hardness or friability of the coal. This is important, as it affects the amount of slack in the final product when put on the locomotive tender.

Some fuel experts contend that a certain percentage of slack in a coal is beneficial. The author believes that run-of-mine coal,

containing not more than 30 per cent. fine coal under 1 inch, is perfectly satisfactory for engine use. Slack, when clean, is readily combustible, yet if there are impurities in the coal, the greatest amount is in the smaller sizes; hence, too much slack should be guarded against. An engine burning fuel containing a large percentage of slack will not show the economy that it will when burning coal containing a larger percentage of lump. It is not economy, therefore, for the fuel purchasing agent to buy a coal that is inclined to make a great deal of slack. It has been found by experiment that there is an increased consumption of 33½ per cent. when using 2-inch nut and slack coal, compared with 5-inch mine run. Engine failures can be attributed often to nothing but slack coal. The personal element of the fireman enters here again, for changing from run of mine, which contains an average percentage of slack, to a coal containing a large percentage, is virtually changing the grade of coal, and the method of firing must change accordingly.

Some kinds of coal, containing a large percentage of slack, are more economical to use than others. For instance, it is more economical to use a coking coal containing a large quantity of slack than it is to use a non-coking coal containing the same percentage of slack, assuming that the fine coal is comparatively clean in both cases. The slack of the non-coking coal will almost instantly be lost through the flues, after being thrown into the firebox, while the coking coal, if previously moistened, will give fair results, if properly fired.

Railroads are sometimes accused of favoritism in placing coal contracts with the larger operators. There is a very good reason for this, namely, that the large companies are, as a rule, responsible, can be depended upon to fill contracts for 12 months of the year, and on account of the size of their investments are in a position to properly prepare the coal. The larger operator can, as a rule, sell a better coal at less price.

The thing for a coal company to do that desires to sell railroad fuel is to show that it can first prepare a good coal at a reasonable price, and then show the railroad company that they are in business for not 3 or 4 months of the year, but are there to get out coal every day they can get their miners in the pit.

While railroads have not as yet taken to purchasing coal on the premium system, yet the day will soon come when the man who buys coal by the trade name, as he does now, will be the exception. Some coal operators may not agree with this, but in support of it, there is a mine where the trade name would have had absolutely no bearing on the kind of coal mined had the trade name been the name of the seam worked, as is true of a large percentage of trade names. The main entry of the mine referred to divides the mine into two distinct districts. The right-hand entries tap a body of coal that is absolutely worthless for steam purposes, while on the left-hand entries, in the same seam, the coal is excellent. In this particular instance a trade name would have been absolutely worthless.

Then again, take two operators working the same seam, within a comparatively short distance of each other. Operator number one is very careful in the preparation of his coal, while operator number two is careless. Operator number two sells his coal on operator number one's reputation, with resulting damage to operator number one's trade. Then again, a coal seam is not necessarily uniform, and a man operating in a part of the seam where the coal is of extraordinarily good quality is hampered by the reputation of the man who is operating where the quality is not so good. On account of variations in the quality of coal seams, trade names, which take the name of the company operating, are also of no value.

采 采

Petroleum in South Africa

The latest reported discovery of petroleum in South Africa is from the Barkly East district of the Cape Province. The analysis obtained by the government analyst at Cape Town states that the sample contains over 80 per cent. of pure paraffin and valuable by-products. Overlying the oil is a great bed of bituminous rock,

extending for 8 miles. This is regarded as superior to ordinary asphalt, and is expected to provide an industry of itself, the obstacle in the way at present being the lack of transport; but if satisfactorily proved, no doubt a railway would be run to the spot, which is at Mosbeshford, close to the Basutoland border.

采 采

Coal Mining Notes

The Largest By-Product Oven Plant.—The Gary, Ind., plant of the United States Steel Corporation has eight batteries of 75 Kopper's by-product coke ovens. Each oven takes 12½ tons of coal for a charge, and the 650 ovens require 9,500 net tons per day. From this coal there is obtained a yield of 84 per cent., or 8,000 tons of coke and the by-products gas, ammonium sulphate, and tar. The gas evolved during the 18-hour coking period is 95,000,000 cubic feet, of which 50 per cent. is used in the steel mills and 50 per cent. is used in heating the ovens.

General Miners Day.—At the instigation of the mine owners of Austria, a committee held a session on December 5, in which the resolution was passed to hold a "General Miners Day" at Vienna in the second half of the month of September, 1912. Chairman, G. Huttemann, Imperial Mining Counsellor; first secretary, Doctor Blanhorn, M. P.

Anthracite Outlook.—That "coming events cast their shadows before" may be the lesson to be gathered from the continued activity shown by the various coal-mining companies in the repairs to old and the building of new fences around their different collieries. We trust this view may not be realized; but they are evidently profiting by the old adage: "In time of peace prepare for war." This and the increasing in capacity of storage plants, and the storage of coal, represents the one side, apparently. The foreigners' remarks of "wait till spring and we'll show them," and the business man's shortness in cash receipts, to which he attributes "the increase in the local banks' reserves," showing some one is laying by money for a rainy day, is the other side. Time will tell. We do not believe there will be a serious strike; but a suspension of mining seems obvious. Anthracite operators are said to be willing to increase wages, provided the miners will continue the Conciliation Board.

Box-Car Loaders for Anthracite.—In some western points domestic sizes in anthracite are at a premium, being 75 cents a ton higher, and hard to get at that. Many are using coke and find it a fair substitute. Realizing the importance of the western trade, some firms have and are installing the Ottumwa box-car loader at their collieries. This machine will easily load from 75 to 100 box cars in a day, receiving the coal into one end of the car and then the other, and trimming it mechanically. Box cars are also used extensively in the eastern and tide shipments.

Fireproof Mine Structures.—The recent enactment of the Pennsylvania Legislature (Act No. 788), which requires all inside structures to be of fireproof material, is causing much additional expense in the operation of coal mines, but it will undoubtedly add to the safety of man and beast, and in addition save annually thousands of dollars in valuable property. This, with the installation of overhoist controllers at shafts, should materially reduce the large annual list of accidents.

Green Mountain Tunnel.—The Highland Coal Co. (G. B. Marple & Co.), who during the past summer let a contract for the construction of a tunnel to be about 1¼ miles in length, connecting its Nos. 1 and 2 Highland collieries, has recently closed another contract with the same firm, D. Rosser & Co., Kingston, Pa., for an additional tunnel at these works which will require several years to complete. These operations will give No. 1 Highland a greatly increased output, as this breaker now also prepares the coal from the Keiper tract, which is situated in the Green Mountain basin, transportation being via an outside locomotive road.

Coal and Zinc.—About 4 miles from Carl Junction, Jasper County, Mo., near the Weaver zinc mine, an 8-foot bed of coal has been found. The coal is found at a depth of 22 feet, and investigation has proven that a good quality of it continues on down to

30 feet. A company is being organized to mine the deposit and furnish coal for the zinc and lead mines in the immediate vicinity. The extent of the deposit is not yet known, but should it be a pocket of good size, it will not need to go far for a good market.

Radley, Kans., Explosion.—While Howard Richards and Napoleon Latinin, two shot firers, were at work at the Radley coal mines on December 9, 1911, an explosion took place which is supposed to have killed both instantly. Men on the surface heard the concussion, but were prevented from entering the mine owing to the afterdamp. One-half hour after the explosion (4:30 P. M.), the first rescue crew went down the shaft; at 5 P. M. another party replaced them; and at 5:30 P. M. several rescue crews were able to enter the mines. The bodies were found a little before 6 P. M. A windy shot is thought to be the cause of the explosion. The value of shot firers in such mines as life savers is once more proven, and if the Kansas operators will install the Utah system of shot firing there is sure to be a further decrease in loss of life.

Anthracite Output in 1911.—The total production of anthracite in 1911 was approximately 92,000,000 tons. The total shipments with the quantity used at the mines for steam consumption is given at 90,000,000 net tons, to which should be added 2,000,000 net tons that were stocked and not marketed.

Bituminous Coal Output in 1911.—The production of bituminous coal in the United States in 1911 will approximate 400,000,000 net tons, there being from 3 to 5 per cent. decrease compared with the output of 1910.

Coke Production in 1911.—Mr. E. W. Parker, of the United States Geological Survey, in a preliminary estimate of the coke production, says it is likely to be from 20 to 30 per cent. less than in 1910, when it amounted to 41,708,810 tons. Whether the difference is 8,341,762 tons or 12,512,643 tons, the estimate is near enough for practical purposes.

Explosives in English Mines.—The following figures, issued in the report of the British Home Office, show the kind of explosives, and the amounts, used in coal and metal mining, and in the other mines and quarries of Great Britain in 1910. From the table it will be noticed that only 28.2 per cent. of the explosives were consumed in coal mines. Of the 44 different permitted explosives used in coal mines, 13.1 per cent. was Bobbinite and 12.4 per cent. Samsonite.

Name of Explosive	Quantity Pounds	Per Cent. of Total
"Permitted" explosives.....	8,607,882	28.2
Gunpowder.....	17,664,483	57.8
Gelignite.....	3,039,256	10.0
Gelatine dynamite.....	494,560	1.6
Blasting gelatine.....	257,756	.9
Blastine.....	165,456	.5
Cheddite.....	123,584	.4
Saxomite.....	118,886	.4
Various.....	66,258	.2
Total.....	30,538,121	100.0

Lackawanna County (Pa.) Mine Inspectors.—Chief Roderick has assigned the Lackawanna County mine inspectors to the following subdistricts: First District, Carbondale, Mayfield, and vicinity, P. J. Moore. Second District, North Scranton and Mid Valley, L. M. Evans. Third District, Mt. Pleasant mine to Throop, S. J. Phillips. Fourth District, lower West Scranton and Taylor, J. T. Reese. Fifth District, Old Forge and vicinity, Augustus McDade. Phillips and Reese are new men, taking the places of H. O. Prytherch and David T. Williams. The former goes back to Wales and Williams retires to enter other business.

Bricville Mine Fire.—According to advices received at the time of going to press, the fire in the Cross Mountain mine at Bricville, Tenn., where recently 84 miners lost their lives, has not been extinguished. This fire, coming so close after the explosion, is an additional hardship on the company, and seems to carry out the adage, "it never rains but it pours."

Commission to Revise Anthracite Mine Laws.—On January 5 Governor Tener announced the appointment of the commission

to revise and codify the present anthracite mining laws of Pennsylvania as follows: Sterling R. Catlin, Wilkes-Barre, State Senator, chairman; Edward E. Jones, Susquehanna County, member House of Representatives; James E. Roderick, Hazleton, State Chief of Mines; W. R. Reinhardt, Shamokin, operator; W. D. Owens, West Pittston, operator; W. G. Robertson, Scranton, operator; Martin Nash, Glen Carbon, Schuylkill, mine worker; H. C. Morgan, Scranton, mine worker; Peter O'Donnell, Wilkes-Barre mine worker. The act of June 14, 1911, creating the commission, provides that it shall consist of nine members, three of whom shall be selected from among the operators, managers, and superintendents of the anthracite region; three from among the mine workers of that region; one shall be a member of the Senate; one a member of the House of Representatives; and one shall be a person versed in the art of mining. Senator Catlin is named as the member of the Senate, and Edward Jones, of Susquehanna County, as the Representative, the Forest City part of the latter's district being included in the anthracite region. James E. Roderick, Chief of the Department of Mines, is the expert picked by Governor Tener. The three operators are well known in mining circles. Mr. Reinhardt is superintendent of one of the Susquehanna Coal Co.'s collieries, at Shamokin, and Mr. Robertson is a widely known Lackawanna operator. Mr. Owens is district superintendent of no less than six Lehigh Valley collieries in and around Pittston. Martin Nash, of Glen Carbon, becomes a national executive officer of the United Mine Workers on April 1. H. C. Morgan, of Scranton, was recommended by President Dempsey, of the United Mine Workers, and Peter O'Donnell is a district organizer of the United Mine Workers.

FATAL MINE ACCIDENTS IN OHIO

	1910	1911
Falls of roof.....	97	81
Electricity.....	7	3
Mine cars.....	19	7
Miscellaneous.....	38	16

New Mining Towns.—The Consolidation Coal Co., of Baltimore, Md., are building the town of Jenkins, on Elkhorn, the town of McRoberts, on Wright's Fork of Boone River, Ky., and it is announced that they will start the third town, to be called Dunham, at the mouth of Potter's Fork on the main line of the Lexington & Eastern Railroad.—C. T. B.

Colorado's Coal Production, 1911.—James Dalrymple, State Coal Mine Inspector of Colorado, in his annual report, furnishes the following interesting data:

TONS OF COAL MINED	
Lignite.....	1,676,975
Semibituminous.....	761,526
Bituminous.....	7,502,981
Anthracite.....	64,379
Unclassified.....	70,000
Total.....	10,075,861
Coke ovens.....	2,764
Coal mine workers.....	13,813
Tons per man.....	729.4

Uniform Mapping of Electrical Equipment.—At a conference of a large number of coal operators, electricians, etc., from various parts of Pennsylvania, Walter R. Calverly, general superintendent of the Berwind-White Coal Mining Co., was empowered to name the committee to devise methods of complying with Paragraph 14 of Section 11, of the new bituminous coal mine code, of Pennsylvania. The paragraph calls for a uniform system of indicating on mine maps places where electrical equipment is in use. At the recent meeting of the Coal Mining Institute of America, H. H. Clark, electrical engineer of the Federal Bureau of Mines, presented a paper on "Electrical Symbols for Mine Maps." Should the committee appointed by Mr. Calverly be guided by Mr. Clark's paper it's work will have been three-quarters accomplished. The committee is as follows: Pittsburg District, E. T. Taylor and Earl Kiser; Irwin-Greensburg District, George W. Lewis and George Shaw; Punxsutawney District, Charles Means and Maurice L. Coulter; Cambria-Somerset District, C. W. Parkhurst and Eugene A. Delaney; Connellsville District, J. P. K. Miller, George Wells.

<div style="border: 1px solid black; padding: 5px; width: 100%; height: 100%; display: flex; align-items: center; justify-content: center;"> 乘 </div>	<div style="border: 1px solid black; padding: 5px; width: 100%; height: 100%; display: flex; align-items: center; justify-content: center;"> Correspondence </div>	<div style="border: 1px solid black; padding: 5px; width: 100%; height: 100%; display: flex; align-items: center; justify-content: center;"> 乘 </div>
--	---	--

Grades for Rope Hauls

Editor Mines and Minerals:

SIR:—Re inquiry in the Correspondence of December issue MINES AND MINERALS "Grade For Rope Hauls." I personally asked this same question about three years ago and received no reply. Since that time I have been operating an endless rope with a screw grab on a slope pitching $17\frac{1}{2}$ degrees. Would be pleased to give Mr. Handley any further particulars he should care to have.

Joggins Mines, N. S.

GEO. B. BURCHELL

Allowable Error in Closing Survey

Editor Mines and Minerals:

SIR:—What is the maximum error allowable in the closure of traverse of mine survey lines. It is common practice to require an angle tie of 2 or 3 minutes, but I have never heard of a mining engineer having a standard maximum error of traverse closure. Such a standard would be convenient, I believe.

The Canadian Public Land Survey has a standard in the form of the equation $e = c \sqrt{D}$ in which e is the error in feet and D is the length of the traverse in miles, but I do not remember the value of the constant c . The form of this standard appears to me to be good, and if it impresses others likewise, I should like their judgment as to the proper value of the constant.

C. G. O.

Coal Dust

Editor Mines and Minerals:

SIR:—There still appears to be much difference of opinion regarding the humidification of mine air. Some time ago Mr. Haas stated that the introduction of exhaust steam "will distribute water uniformly and in any quantity desirable, with no attention and entirely free from human opinion or direction."

Later on he modified this statement a little and said: "The object of saturating a mine atmosphere with water vapor is not for the purpose of furnishing the water for wetting the mine, as is sometimes supposed, but for preventing the evaporation of such water as is naturally there or such as has artificially been supplied."

He also stated: "The mining man has in recent years been compelled by law to keep his mine wet. But he has found in attempting to comply with the laws, in so far as keeping all parts of his mine wet by the sprinkling method, that he has undertaken an impracticable proposition."

Mr. Haas makes this additional statement, which appears to be sound: "Fog in working places, manways, or haulage roads is an objectionable feature and should be avoided. This would demand that if steam is introduced into the air-current it should be in the air-course where no person is supposed to travel except for inspection or repairs, and that a blowing fan be used. The system can be used, however, with an exhaust fan, but it would require other than the ordinary entries for the intake."

I was surprised a few days ago when discussing this system with one of its advocates to hear him say that it was immaterial whether a blowing or exhausting fan was used. All that was necessary was to install heaters or radiators at the mouth of the intake to raise the temperature above the temperature of the interior of the mine. Allow the steam to escape through small holes in the pipes at the inby end of the coils. The humidity of the air will then be 100 per cent., and there will be no fog in the haulage road.

I would like the opinion of some of your readers on the above statement. I would also like to know, if there are mine roofs which will not stand sprinkling, and steam is not for the purpose of furnishing water for wetting the mine, how such roofs are to be made wet? The method I favor is schistification, which means the innoculating of coal dust with shale or stone dust. In the experimental galleries stone dust zones have always stopped coal-dust explosions.

But I do not advocate zones. I believe in sprinkling stone dust, especially on the roof and sides all the way from the shaft bottom to the face. I believe it can be applied in many mines where steam is now used, the humidity produced by the steam being no detriment to the stone dust inby. And additional safety will be added.

Delagua, Colo.

SAMUEL DEAN

Siphons

Editor Mines and Minerals:

SIR:—In reply to the inquiry of H. L. G., of Tracy City, Tenn., I would say that if it was possible for him to construct his siphon of one continuous pipe without joints, eliminate all friction, and also eliminate the air in the water, a siphon such as he describes would work splendidly and would probably produce the exact results shown by calculating the standard formulas for such cases. But as a practical proposition I would call his attention to a somewhat similar case, described in Trautwines' Engineer's Pocketbook, eighteenth edition, page 521. The description is as follows:

"At Blue Ridge Tunnel, Virginia, Col. C. Crozet constructed a drainage siphon 1,792 feet long, of cast-iron faucet pipes, 3-inch bore, 9 feet long. Its summit was 9 feet above the surface of the water to be drained, and its discharge end was 20 feet below said surface, thus giving it a head of 20 feet. At the summit, 570 feet from the inlet, was an ordinary cast-iron air vessel with a chamber 3 feet high and 15 inches inner diameter. In the stem, connecting it with the siphon, was a cut-off stop-cock, and at its top was an opening 6 inches in diameter, closed by an air-tight screw lid. At each end of the siphon was a stop-cock. To start the flow these end cocks are closed and the entire siphon and air vessel are filled with water through the opening at the top of the air vessel. This opening is then closed air-tight, and the two end cocks afterwards opened, the cut-off cock remaining open. The flow then begins and theoretically it should continue without diminution, except so far as the head diminishes by the lowering of the surface level of the pond. But, in practice with very long siphons this is not the case, for air begins at once to disengage itself from the water, and to travel up the siphon to the summit, where it enters the air vessel, and rising to the top of the chamber gradually drives out the water. If this is allowed to continue, the air would first fill the entire chamber, and then the summit of the siphon itself, where it would act as a wad completely stopping the flow. The water level in the air chamber can be detected by the sound made by tapping against the outside with a hammer.

"To prevent the stoppage, the cut-off at the foot of the chamber is closed before the water is all driven out, and the lid on top being removed, the chamber is refilled with water, the lid replaced and the cut-off again opened. The flow in the meantime continues uninterrupted, but still gradually diminishing, notwithstanding the refilling of the chamber; and after a number of refillings it will cease altogether, and the whole operation must then be repeated by filling the whole siphon and air chamber with water as at the start. At Colonel Crozet's siphon at first, owing to the porosity of the joint caulking, which was nothing but oakum and pitch, air entered the pipes so rapidly as to drive all the water from the chamber and thus require it to be refilled every 5 or 10 minutes; but still in 2 hours the siphon would run dry. The joints were then thoroughly recaulked with lead, and protected by a covering of white and red lead made into a putty with Japan varnish and boiled linseed oil. But even then the chamber had to be refilled with water about every 2 hours, and after 6 hours the siphon ran dry, and had to be refilled. In this way it continued to work."

As a practical engineer, I consider this authentic and well-described description of the actual working of a somewhat similar siphon to that described by H. L. G., will give that gentleman a more accurate answer to his question than if I used up several columns of mathematical formulas, and it will enable him to determine whether a siphon requiring such care and attention in both construction and operation, considering also its liability to frequent stoppages, is as efficient and economical as a pump would be.

Pittsburg

J. R. F.

Method of Mining Coal

Filling Rooms by Blasting Floor Up and Roof Down to Occupy the Worked-Out Space

By William Griffith *

In mining bedded or stratified deposits of metal or coal one general plan or system is used with variations. In mining coal the usual system in the United States is what is known as the room-and-pillar system. This method of mining is varied somewhat necessarily on account of the disposition of the coal veins in the rock, for permitting mining on flat or horizontal veins, and in pitching veins. The mining of flat or horizontal veins by the ordinary method contemplates the sorting of the coal from the refuse in the room or part of the mine where it is removed from its natural bed, and the refuse material, such as slate, bony coal, fireclay, and rock, is left in the room, and the coal is loaded in the cars and taken out. In cases where coal occurs in such a steep pitch that the loose material will slide down and not remain where deposited, it is necessary to remove all of the mined matter loosened by the mining operation, including coal and refuse matter, which coal and refuse matter must be sorted after having reached the surface.

In mining coal according to the present method approximately one-third of the coal in the vein is left in the mines to support the roof. In some instances other methods are used where all of the coal is taken out and the roof is purposely allowed to fall, and in other instances foreign matter, as stone, sand, and the like, is brought into the mine, and the mine is filled therewith as fast as the coal is removed, so as to prevent the roof from falling.

This invention is intended to obviate as far as possible any injury or breaking down of any property on the surface of the ground, and at the same time to render available for shipment larger quantities of coal from a given coal field than is now possible to mine without endangering the lives of the miners or life and property on the surface of the ground.

The process or method consists briefly in blasting up the floor which is usually rock, or blasting down the rock roof of the mine, or blasting up the floor and the roof directly over it, allowing the debris of the blasting to remain where it falls, thus taking advantage of the well-known characteristics of blasted rock, that it occupies considerably more space than when in the solid condition. Preferably the floor is first blasted up and caused to fill approximately half of the room or opening; that is, not only to fill the space from which it was blasted, but also to cause a pile of blasted rock to occupy approximately half of the vertical space of the room, and then a sufficient part of the rock roof is blasted for filling the remainder of the space. It will be noted that the blasted rock remains at the point blasted, and is not moved from one place to the other, but is always blasted wherever wanted, and in the desired quantities. The debris from the blasting will fill up the total space and afford a safe support for the overburdened roof of the coal mine, and will allow but little subsiding of the earth above the mine, and any such subsiding will be small and will take place gradually at different times.

In the accompanying drawings is shown a concrete example of the process involved. Either after the mine has been partly worked or abandoned or during the mining operation a plurality of drillings or borings *a* are provided from room *b*. The borings *a* are in the roof while similar borings *c* are provided in the floor.

In these respective borings are placed dynamite or other explosives which are arranged to be set off by fuses or any other desired means. These borings are made sufficiently deep for blasting up sufficient rock to fill the hole formed in either the floor or roof, and to also fill approximately half the room *b*. Preferably the charges in the first one or two holes are set off, and then one or two charges immediately above are set off for blasting up and down the floor and roof, as shown more particularly in Fig. 2. After this has been done, one or more charges in the floor are set off, and again one or more in the roof. This alternate setting off of the charges is continued for any desired distance, as shown in Fig. 3, for filling room *b* to any desired extent. If it is desired to remove the pillars *d* the room *b* is preferably entirely filled with this blasted rock (Fig. 6), and then the pillars each side removed, after which the rooms on each side are filled with blasted rock in a similar manner to that just described. If it is desired to remove all the coal during the first mining no pillars of coal are left at all, their places as roof supports being occupied by the blasted rock from the roof and floor—the excavations of the mine being gradually thus filled (or as nearly so as necessary) as rapidly as mining advances. It will be evident that if desired the floor and roof may be blasted at the same time, or either the floor or roof may be blasted independently, for filling

the entire space. By this arrangement of providing a support for the roof, the roof is supported by the usual pillars, and by this auxiliary support. If it is desired the pillars of coal may be removed, leaving nothing but crushed rock for supporting the roof, which roof will subside but little, and such subsiding will be very slow.

In Figs. 4 and 5 the principle involved in the invention is shown as applied to pitching veins where the vein *e* is at considerable angle. In a mine of this character an entry *f* is provided for the usual mining car, and from this entry an opening *g* is dug for a short distance into which opening is placed a chute *h*. Chute *h* may be made of timber, metal, or of any other desired material, and is designed to permit the entrance of the workmen and to present means for directing the mined coal to the car *i*. The chute *h* fills the opening *g* so that the workmen may throw all of the coal in the chute which will pass out and be dumped in car *i*, while the slate, and

other refuse material, will be dumped in the bottom of the opening or mined room. As the coal is dug away from above and it is found that there is not sufficient slate or other refuse matter to provide supporting means for the workmen, part of the roof is blasted down. This acts in a double capacity, namely, as a platform or scaffolding for supporting men, and also as a roof support for preventing the collapsing of the mine. By this arrangement all of the coal may be mined. Heretofore in mining pitching veins all of the coal and slate and other matter mined was removed, but by this arrangement of means and process for carrying out the same nothing is removed except the coal.

The method embodying the invention is aimed to not only protect the miners while at work, but to protect the surface property, and in addition to permit the removal of all of the coal from the mine. The cost involved is reduced to a minimum by utilizing the crushed rock already in the mine at the place blasted or operated upon.

In old or abandoned mines the method of operation on the floor and roof may be employed for affording ample support for the superimposed strata for holding up the same properly, and also any property on the surface. This method may be used simply as an auxiliary support in old mines for assisting the pillars therein, or may be used as the entire support for the roof of an old mine when it is desired to remove the pillars therefrom.

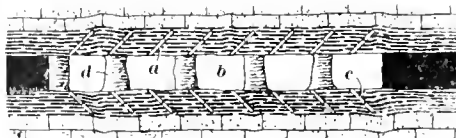

FIG. 1

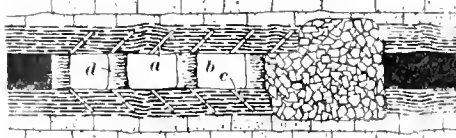

FIG. 2

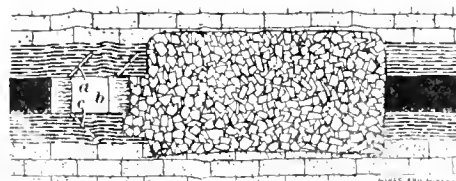

FIG. 3

*Application filed March 6, 1911. Serial No. 612,668.

What I claim is:

1. The method of mining comprising blasting the floor of the mine for partially filling the mine at the point of blasting, and then blasting down a sufficient part of the roof for filling the remaining open space in the mine, the blasted material being allowed to remain where it falls for filling the open space in the mine and the space caused by blasting, for providing supporting means for the roof.

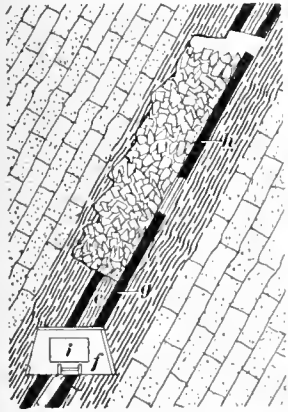

FIG. 4

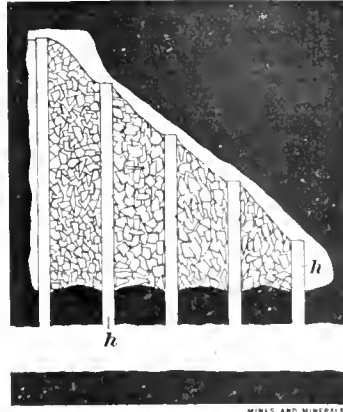

FIG. 5

2. The method of mining which comprises the running of gangways along the body of the material to be mined, forming rooms at one side and connected to these gangways, taking out the material to be mined and packing the refuse in said rooms on the side of the rooms, blasting up part of the floor of the rooms for filling the space out of which the mined material has been removed, and which has not been filled by the refuse, the blasting down a sufficient part of the roof for filling the remaining opening in the rooms not filled by the blasting up of the floor and refuse matter.

3. The method of mining which comprehends running gangways along the body of material to be mined, working out the waste material in the space from which the mined material has been removed, and blasting down a sufficient part of the roof by completely filling the space provided by removing the mined material when taken with the waste material placed therein.

4. The method of mining which comprehends taking out the material being mined, the erecting of a chute in the opening formed by the removal of the mined material, the placing of the waste material in the bottom of the opening provided by the removal of the mined material, discharging the mined material through said chute, and blasting down from the roof a sufficient part thereof for filling the space provided by the removal of the mined material which is not already filled by the waste material for providing a roof support.

5. The method of mining which consists in driving in the vein to be mined, a series of entries for haulage and airways, the entries being spaced apart so as to leave pillars heavy enough to sustain their normal share of the superimposed strata, and the working out of rooms at one side of these entries, placing charges of explosives in the floor and roof of the rooms, and successively discharging the explosives in the floor and roof for filling the rooms with crushed material from the floor and roof for providing auxiliary supports for the roof.

6. The method of mining which comprises the running of a gangway along the body of material to be mined, forming rooms to one side of the gangway, and connecting the rooms to the gangway, blasting up part of the floor of any of the rooms, and leaving the blasted material in the place where it falls, and then blasting down a sufficient part of the roof for filling the space immediately above the first mentioned blasted material for providing an artificial pillar for supporting the roof.

7. The method of mining which comprehends forming explosive receiving bores in the roof and floor of the mine, placing explo-

sive material in each of said bores, exploding the explosive material in part of the bores of the floor, exploding the explosive material in part of the bores of the roof arranged above the explosive material exploded in the floor, and then exploding the explosives in the bores of the floor and roof alternately until the desired supporting pillar is provided.

8. The method of mining which comprehends the placing of an explosive in the floor of an abandoned mine, the placing of an explosive in the roof of the mine, and exploding the explosives in any desired sequence, and leaving the matter loosened by the explosives in the place where it falls for providing a support for the roof of the mine.

采采

Ventilating Blind Chutes in Gaseous Mines

For many years in mines in the anthracite region, generating explosive gas, particularly where the seams were of a comparatively heavy pitch, it was customary to ventilate the chutes driven 10 or 12 yards up the pitch before encountering the first heading, with sheet-iron hand fans turned by a boy, the air being conducted from the gangway to the face of the chute in wooden pipes 10 or 12 inches square.

This method required the constant work of a boy, and as it was exceedingly monotonous the boy either fell asleep or his arm becoming tired he at times ceased turning the fan. The miner driving the chute did not always notice the stoppage of the fan until a cap appeared on the flame of his safety lamp, or until the lamp ignited the gas and he was more or less severely burned, as was occasionally the case with the boy. When the miner discovered the fan had stopped before anything happened there was apt to be an explosion of another kind, which was of a vocal character, and strong language was hurled at the offending boy.

John M. Humphrey, division superintendent of the Lehigh Valley Coal Co., has devised a simple means of doing away with the old noisy sheet-iron fan and the service of a boy to run it at mines where electric power is used. His plan is to take an ordinary electric office fan and enclose it in a box with openings at both ends. One of the openings in the box is attached to an ordinary square wooden pipe and the other left free for the ingress of fresh air. By attaching the wires from the fan to the feed-wire used for carrying electric power, the

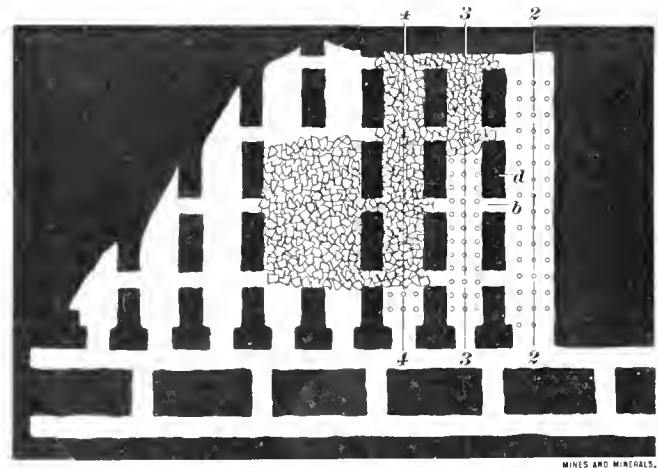

FIG. 6

fan is started, is kept constantly in motion, and blows the air up the chute with greater regularity and more volume than any boy turning the old fan could possibly furnish. In addition, the cost of the fan is really no more than the cost of the old-fashioned, clumsy, and inefficient hand fan.

Mr. Humphrey's idea can, under certain conditions, be used to considerable advantage in all kinds of mines where electric power is available.

Wire Rope as Applied to Mining

Different Makes of Rope. Methods of Testing. Calculations.
Length of Life of Rope

The following is abstracted from Mr. Dugald Baird's paper in the Transactions of the Mining Institute of Scotland.

To the mine manager the care of wire ropes is of the greatest importance, therefore he should have knowledge of their construction, quality, testing, and preservation, that he may have confidence in them and be able to select the best kind of rope for the work to be performed. The following remarks relate more particularly to winding ropes, but they are applicable to haulage ropes unless otherwise stated. Wire-rope makers have gone to considerable expense to publish many good tables, rules, and instructions on wire ropes. These have been guides to users of ropes and the makers are most willing when asked to advise as to the kind of rope to use under given conditions. Some managers are satisfied to leave the selection of the rope entirely to the makers, after they have furnished the particulars under which the rope has to work. This, however, is no reason why a manager should be unable to judge the kind and size of rope wanted, and it is possible that both the manager and the rope maker are needed to determine the correct size and kind of rope required.

The various materials from which a selection of wire ropes may be made are wire, Bessemer-steel wire, patent-steel wire, and plough-steel wire. Iron wire has a tensile strength of from 30 to 40 tons per square inch; Bessemer-steel wire from 45 to 60; patent-steel wire from 65 to 90; and plough-steel wire from 95 to 125. It should be noted that the tensile strength can be so shaded in wire drawing that the higher strength can be gotten from inferior metal. In specifications for wire ropes, therefore, more than tensile strength should be mentioned. When inferior metal is drawn to give a higher tensile strength than is natural, it becomes brittle and will not stand the test, then a bending test may be added which is more trying and more conclusive. The fatigue test commonly used in America, is performed by passing the wire over two wheels, one several feet vertically above the other. The ends of the wire are glanded together, a weight is hung on the lower pulley and the wire is made to run up and down between the pulleys until it breaks, the number of trips being noted by a counter. When a rope is tested in this manner the wheels have a size proportioned to the size of the wire thus bringing the conditions of this test nearer to the working test than any other. Rope specifications should contain data on the weight to be lifted including the weight of the rope; the diameter of the drum and sheave wheels, and the speed of winding, and the makers should be asked to send a full specification of the rope offered with their guarantee as to tension, torsion, and bending. After the rope is received, 3 feet cut from the end will be sufficient for all three tests. These results of the tests are to be entered in a rope book for future reference, and if the wires do not come up to the guaranteed figures the matter is to be taken up with the makers. If the results are seriously under the guarantees, a new rope will be required. It may be assumed that only a few managers have the necessary testing machines at their command and it is suggested that some responsible engineering firm should be approached with a view to having a rope testing station added to its establishment where ropes could be tested with accuracy and expedition.

Usually tests are made of individual wires and the results averaged, but with a suitable establishment the fatigue test as well as that of testing the whole rope at once could be performed.

In the absence of a machine suitable for testing the rope as a whole, the next best course is to take the rope to pieces and test the wires individually. The sum of the breaking strains of the several wires, less a percentage for combination, gives the breaking strain of the rope. This percentage deduction varies with the size and the construction of the rope from 5 per cent. with a 6-strand 7-wire rope to 17½ per cent. with a 6-strand 37-wire rope, but the

average may be taken at 10 per cent. Makers' tables are based on the average breaking strain of the individual wires, and 10 per cent. should be deducted from the total breaking strain in order to reduce the results to the actual breaking strain.

The testing of a rope, after the testing machines and the tables necessary to guide in the results are obtained, is the simplest part of the whole matter. What is more difficult is laying out the engines, drums, pulley wheels, and cage chairs, so as to give the rope the best chance of doing a large amount of work before it requires to be taken off.

The following enumerate the more important points, and a few practical remarks are offered on them without pursuing the subject to scientific conclusions:

1. The drum should be at such a distance from the shaft mouth that the angle of the lead of the rope should be under 2 degrees when the cage is at the top, otherwise the side wear on the rope will be excessive.

2. The drum should be of sufficient size to admit of rope being only one course deep. If in certain circumstances this is impossible, then a simple step should be provided for the rope where it mounts for the second course.

3. The diameter of the drum and the pulley wheels should not be less than 100 times the diameter of the rope and a thousand times the diameter of the thickest individual wire in the rope.

4. A rope lasts longer if there are no cage rests at the pit bank, and it is better for the cage at the pit bottom to have, if resting, no slack rope, for it has been proven that 6 inches of slack doubles the strain on the rope when the load is lifted.

5. The pulley wheels should be so proportioned and of such material as to prevent them remaining stationary, when the rope is let out, or continuing to revolve after the cage comes to the bank. There is nothing so detrimental to a rope as this, and its prevention is a problem that has not been properly solved. If a white mark is put on the wheels and the total revolutions made during a rapid wind counted, there will be cause for astonishment when they are compared with the total which should be made if there were no slip. As much as 50 per cent. of slip may sometimes be noted even when the wheels are neither excessively large nor excessively heavy. A dressing of stiff rope oil partly cures this defect but care should be taken that the substance put on contains no acid that will attack the wire. If, however, the rim of the pulley is made narrow enough at the bottom so that about one-third of the circumference of rope is supported by it and at the same time is wide enough at the outside of the groove for the angle of lead of the rope, the tendency to slip will be less.

6. All winding ropes should be specially constructed. In Lang's lay rope the wires in the strand and the strands themselves are twisted in the same direction, whereas in ordinary lay they are twisted in opposite directions.

7. Where the drums are lagged with wood it is desirable to have a groove turned all the way around so that the rope does not rub on itself as it coils on and off the drum. The pitch of the groove thus formed should be such as to have a space of about $\frac{3}{32}$ inch between the coils of the rope. This is always a good arrangement, but it is indispensable when the drums happen to be too close to the pit, otherwise the rope will be apt to ride on its neighboring coil before the outer edge of the drum is reached.

8. In all cases the wires of the rope should be as large as possible, consistent with the size of the drum and wheels, so that they may take longer to wear through. Compound ropes lend themselves to this better than ordinary wire ropes of 6 strands of 7 wires each, as the inside wires being smaller the outside wires will be larger and the rope will still have sufficient flexibility.

The different kinds of ropes in general use are 6 strands of 7 wires, 6 strands of 12 wires, 6 strands of 19 wires*, 6 strands of 24 wires, 6 strands of 37 wires. These are selected in accordance with the conditions under which they are required to work.

9. Unless in very favorable situations, where a thick coating

* This kind of rope with hemp core is usually adopted for hoisting in the United States.

of preservative can be put on and maintained so that scarcely any of the wires can be seen, which is itself a drawback for examining purposes, all winding ropes should be galvanized.† The galvanized coating preserves the inside of the rope from rust, so that when the rope is examined and no broken wires are seen it is tolerably certain that there are none inside. So long as external wires remain whole and the rope is not too much worn, it can with safety be worked longer than if it were not galvanized. It is found in practice that galvanizing plough steel of a tensile strength of 115 tons per square inch and more, makes the wires more brittle than wires of a lower tensile strength, and where galvanizing is desired a very high tensile strength should not be asked for. With the tensile strength under 115 tons per square inch the reductions caused by galvanizing appear to be as follows: Tensile strength $2\frac{1}{2}$ per cent., torsion 20 per cent., bending 25 per cent.

10. The time which a winding rope should be kept in service depends upon the conditions under which the rope is working, but if of the proper material, size, and construction for the work, it will vary from $1\frac{1}{2}$ to 6 years, and the writer's experience is that a 50 per cent. longer life can be gotten with galvanized ropes than with bright wire ropes. They of course require to be greased like other ropes in order to reduce the internal friction. A well-oiled rope will last twice as long as one neglected and left to run dry. When broken wires begin to show it is time to take the rope off, and especially so if the broken wires are near each other. The most common place to first find broken wires is near the drum, when the cage is at the bottom of the shaft, as that is the place of greatest strain. They may also be found near the cage fastening, where they may be gotten rid of by resocketing, but there is no cure for those near the drum. If a rope is made of such excellent wire that the wires will wear down considerably and not break, the reduced circumference of the rope will be a good guide as to when it should be taken off. If, when new, the rope has a factor of safety of 10, and it measures $1\frac{1}{4}$ inches in diameter or $3\frac{1}{2}$ inches in circumference, and after it is worn it is found to be only 1 inch in diameter or $3\frac{1}{2}$ inches in circumference, then its factor of safety will be about $6\frac{1}{2}$, which is too small. It will be found that if internal corrosion is going on the rope will shrink into a smaller diameter more quickly, and where there is any evidence of this the rope should be replaced at once. Ropes have actually been known under such conditions to break in two when taken off.

A few simple rules may not be out of place here. There is nothing original about them, but they are easily remembered and it saves time in consulting tables which may not be at hand at the time.

If C equals the circumference of a rope in inches, then the breaking strain of a rope, in tons, if made of 100-ton wire, equals $C^2 \times 4$, and all others in proportion, so that if a Bessemer-steel rope is being considered, $C^2 \times 2$ will be the rule, 10 per cent. being as usual taken off for construction. This rule does not apply to special makes of ropes, such as locked-coil wire ropes and others having a larger amount of metal in a given area, but only to ordinary 6- or 7-strand wire ropes with hempen cores. The weight per fathom of these ordinary ropes may be taken at C^3 equal to pounds per fathom.

EXAMPLE.—A rope 4 inches in circumference made of 100-ton wire will weigh 16 pounds per fathom and have an aggregate breaking strain of $(C^2 \times 4) = 64$ tons, less 10 per cent. for construction, or 57.6 actual breaking strain, and with a factor of safety of 10, a working load of 5.76 tons; or, if a factor of safety of 11 be taken, the 10 per cent. for construction may be left out and the result will be practically the same.

Ropes for sinking purposes are, or should be, of non-rotating construction, and can now be obtained from almost any maker. These ropes are constructed of two ropes, one inside the other, and laid in the opposite direction to each other. When they are taken off a reel and put on the drum, care should be taken to prevent them from turning, as they are liable to get out of the twist and so bring about what is called "bird-caging." If properly handled

at the first they are not likely to give any trouble. Such ropes are most useful for sinking purposes, but it is doubtful whether they are to be recommended for ordinary coal winding. Crab ropes should also be constructed so as to be at least partly non-rotating, that is, the core should be Bessemer steel and twisted the reverse way to the rope. They are not absolutely non-rotating, but serve the purpose of a crab very well.

Flat ropes for winding purposes are sometimes used. They consist of 6 or 8 small ropes, $\frac{1}{2}$, $\frac{3}{8}$, $\frac{3}{4}$, or 1 inch in diameter, according to the strength wanted, and are stitched together with Bessemer wire. They are more expensive than round ropes, and usually give trouble by splitting asunder, and in such a case need to be restitched. The only point in their favor is that they give an ideal scroll drum movement similar to that of flat hempen ropes, so that engines of smaller size will do the same work as larger engines would do with a parallel drum. Everything considered, they are, in the writer's opinion, not to be recommended, as they do not give a long life. Even with moderate winding, from 2 to 3 years is a fair average life.

Other two questions as to the life of winding ropes are raised here, chiefly for the purpose of drawing forth the experience of others:

1. Does the rope coming off the top of the winding drum or the one coming off the underside of it have the longer life? The generally accepted answer is in favor of the top rope, as both of the bends it makes are in the same direction, whereas the lower rope bends first one way and then the other. So far as the writer's experience goes, it is found that the difference, if any, is not pronounced.

2. Does a rope running on a wood-clad drum last longer than one running on iron or steel cleading? The writer has no recorded experience on this point, but he understands that the difference is very much in favor of wood, and this fact ought therefore to be better known than it is at present.

Mr. William Jarvie (Bothwell) said that, in the construction of haulage ropes especially, so many factors had to be considered that managers must cooperate with the makers to get the best result. The proper size of a rope was easily determined, but the system of haulage, tension, size of pulleys, kind of haulage clip, and protection against water, all required careful consideration in the construction of the rope.

While Mr. Baird advocated Lang's lay for all winding ropes, Mr. Jarvie's experience was very much in favor of ordinary lay. He found with the former that the strands opened out and admitted water, allowing the rope to stretch, with the result that the life of the rope was considerably shortened. This remark also applied to endless haulage ropes with Smallman or similar clips.

He thought that the brittleness of wires when galvanized was a very serious disadvantage, and that galvanizing should only be adopted where the water was exceptionally corrosive.

He did not altogether agree with the proposal in the new Coal Mines Bill to limit the life of all winding ropes to $3\frac{1}{2}$ years. The average life of their winding ropes was nearly 4 years, and he has seen ropes taken off after fully 5 years work without a broken wire. The compulsory systematic resocketing of ropes was, however, very desirable.

Taking the figures for eight winding engines over a period of 15 years, he found that the life of the rope coming off the top of the drum averaged about 3 months longer than the other. He was inclined to regard this as a coincidence, as two of the underside ropes had the longest lives.

He had tried plough-steel winding ropes, but had discarded them, as they compared very unfavorably with patent improved steel in the cost per 100 tons raised.

Mr. Baird's remarks on the slip of winding pulleys were most interesting, and he was greatly surprised to learn that the slip could amount to 50 per cent., even over the period of retardation.

A recent accident in a blind pit, with a rope $2\frac{1}{2}$ inches in circumference, had impressed upon him the danger of internal corrosion. No signs of weakness were apparent to two men who

† Not the editor's opinion.

examined the rope before the accident. A portion of the rope next the break gave a breaking strain of 20 tons, with a satisfactory torsion test, yet the rope broke under a strain which could not have exceeded 1 ton.

He agreed with Mr. Baird that very few collieries had satisfactory machines for testing ropes, and believed that the proposal to establish a rope-testing station would find support.

Mr. R. W. Dron (Glasgow) said that when one considered the small cost of winding ropes in relation to the tonnage of output, it seemed unnecessary to incur any risk such as might be run by using a rope for 5 or 7 years. In his opinion a winding rope ought not to be run beyond the period that the new Mines Bill stipulated, namely, $3\frac{1}{2}$ years. While 99 ropes out of 100 might work quite safely for a longer period, still there was always the risk of some unseemly flaw. Some years ago he had experience of a case of this kind, where a winding rope broke while drawing an empty cage. The rope had been in regular use for fully 3 years, but as far as external examination went it appeared to be in quite a sound condition. It was well oiled and cared for, and had been subjected to no unusual conditions. It was in the downcast shaft, and there was no acid water in the shaft. The colliery had been in operation for about 20 years, and this was the only occasion on which there had been a failure of a winding rope. An examination of the rope after the accident showed a very serious amount of internal corrosion which at once accounted for the breakage.

On the question of galvanizing, he would point out that if a rope had to be galvanized, there must be allowance made for a lower tensile strength. This, of course, involved a heavier rope, and it would be an interesting calculation to know how many extra tons of coal were to be burned in the course of the year in order to wind this heavier load. When they counted up the extra cost of the fuel and the extra cost of the galvanized rope, they would find that there was no advantage whatever. Then they had always to remember that galvanizing made the rope more brittle and unreliable. Generally speaking, for ordinary mining work the non-galvanized rope was better. The new Mines Bill stipulated that winding ropes were to be recapped every 6 months, and this was a very wise provision.

Mr. Robert A. Muir (Bothwell) said that he agreed in great measure with what Mr. Baird had written in his paper. Mr. Baird had mentioned the unsuitability of the non-rotating sinking ropes for winding and Mr. Muir also had experience with them, and had found them most unsuitable for the purpose. He also agreed with Mr. Baird in regard to wood-clad drums. He had had experience of drums with iron and steel cladding, and had found them unsuitable. In a case which he had in view, a number of wires were broken in the rope just where the rope touched the drum when the cage was at the top, and he thought that the damage must have been due to the vibration of the cage on the steel-clad drum, causing crystallization and ultimately breakage of the wires at that point. Wooden cladding was put on top of the steel plates and no more broken wires were found at that point.

Another important point was to take great care not to have rope too long or the connecting chains too short, as great damage was done by the socket resting on the top of the cage and knuckling over, thus bending and breaking the rope at the end of the socket. He had known of two cases of ropes breaking on that account.

In regard to the greasing of ropes, he did not think that a proper greaser had as yet been invented. He had some little

experience of one in which the grease was pushed into the rope by means of steam pressure in the form of spray, and this did exceedingly well.

來 來

Oxygen Stretcher

In rescue work after a coal-mine explosion it not infrequently happens that a man is found, unconscious but still breathing, beyond a stretch of bad air. Could the man so overcome be safely brought to daylight, in many cases his life might be saved by the application of a pulmotor, or some similar device. In order to carry a helpless patient through bad air D. H. Reese, foreman in charge of the instruction car of the Victor-American Fuel Co., Hastings, Colo., uses a combination of an ordinary stretcher with the standard form of oxygen apparatus which has proved very effective whenever tried.

The outfit consists of a stretcher of extra heavy canvas to which is fastened a complete set of Westphalia oxygen apparatus, in the position shown in Fig. 1. The oxygen tank rests in a steel bracket fastened to the bottom of the stretcher, and when empty may be replaced in a few seconds. The indicator, reducing valve,

breathing bag, hose, etc. are all of the standard pattern and interchangeable with similar parts used by the regular rescue crews. The face mask is fastened on with double straps. It will be noted that straps are provided to securely fasten the patient upon the stretcher in event of his having to be carried over falls or the apparatus has to be "up ended" when placed on a cage. The breast strap is 3 feet long and 2 inches wide; that over the hands, 5 feet long and 1 inch wide, and the abdominal and leg straps each 3 feet long and 1 inch wide.

In actual practice it is found possible to have an unconscious patient breathing oxygen within 1 minute of his discovery, and strapped upon the stretcher within 4 minutes more. The entire apparatus as used by Mr. Reese weighs 42 pounds.

來 來

Catalogs Received

ALLIS-CHALMERS Co., Milwaukee, Wis., Bulletin No. 1523, Portable and Stationary Air Compressors for Industrial

Purposes, 16 pages; Bulletin No. 1524, Price List of Repair Parts for Auxiliary Air-Brake Apparatus, 16 pages; Bulletin No. 1625, The Hydro-Electric Development of the Great Northern Power Co., 16 pages; Bulletin No. 1800, The Richards-Janney Classifier, 24 pages.

AMERICAN BLOWER Co., Detroit, Mich., folder entitled "A Factor in Efficiency."

ALDRICH PUMP DEPARTMENT, Allentown, Pa., Bulletin No. 21A, Pump Data, The Aldrich Vertical Quintuplex Electric Mine Pump, 12 pages.

BALDWIN LOCOMOTIVE WORKS, Philadelphia, Pa., Record No. 71, Locomotives for Industrial and Contractors' Service, 32 pages.

CHICAGO PNEUMATIC TOOL Co., Chicago, Ill., "Chicago Pneumatic" Compressors for Air and Gas, 12 pages; Bulletin No. 34A, Class G "Chicago Pneumatic" Steam-Driven Compressors, 16 pages; Bulletin No. 34C, "Chicago Pneumatic" Tandem Gasoline-Driven Compressors, 15 pages; Bulletin No. 34E, "Railroad" Type Straight-Line Duplex Steam-Driven and Belted Compressors, 18 pages; Bulletin No. 34H, General Instructions for Installing and Operating "Chicago Pneumatic" Compressors, 16 pages.

THE DEANE STEAM PUMP Co., 115 Broadway, New York, N. Y., Triplex Power Pumps, Vertical Double-Acting, 32 pages.

THE GOULDS MFG. Co., Seneca Falls, N. Y., Bulletin No. 107,

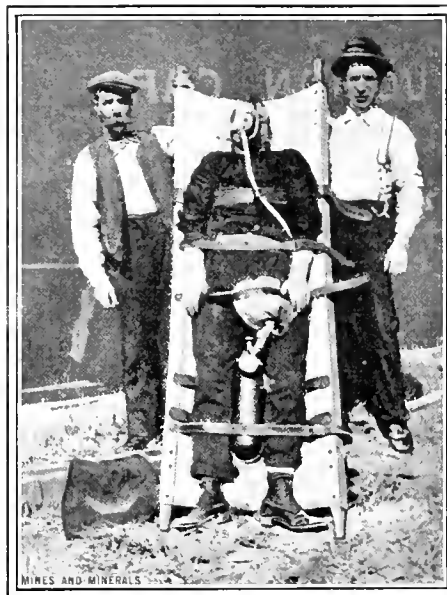

FIG. 1. MAN AND OXYGEN APPARATUS STRAPPED TO STRETCHER

Deep Well Triplex Pumps, 12 pages; Bulletin No. 108, Deep Well Working Heads, 12 pages; Bulletin No. 109, Pumps for Special Services, 20 pages.

GENERAL ELECTRIC Co., Schenectady, N. Y., Bulletin No. 4912, General Electric Ozonators, Ozone and Ventilation, 14 pages; Bulletin No. 4892, Battery Truck Crane, 9 pages; Bulletin No. 4895, Electric Fans, 39 pages.

INGERSOLL-RAND Co., 11 Broadway, New York, N. Y., "Imperial" Valveless Telescope Feed Hammer Drill (Type "MC-22"), 16 pages; "B-104," "Sergeant" Rock Drill, 4 pages.

THE SCHAEFER & BUDENBERG MFG. Co., Brooklyn, N. Y., Columbia Recording Thermometers, 38 pages.

ROBINS CONVEYING BELT Co., New York, N. Y., Bulletin No. 47, Ore, Robins System, 80 pages.

E. I. DUPONT DE NEMOURS POWDER Co., Wilmington, Del., The Sport Alluring, 36 pages.

ELECTRIC WEIGHING Co., 180 Thirteenth Avenue, New York, N. Y., The Electric Weigher for Weighing Ore, Coal, Cement, and All Materials in Bulk, 15 pages.

CALENDARS RECEIVED

ROESSLER & HASSLACHER CHEMICAL Co. 100 William Street, New York.

BALDWIN LOCOMOTIVE WORKS, Philadelphia, Pa.

JOHN A. ROEBLING'S SONS Co., Trenton, N. J.

YORK BRIDGE Co., York, Pa.

THE ALDRICH PUMP DEPARTMENT, Allentown, Pa.

WATT MINING CAR WHEEL Co., Barnesville, Ohio.



Personals

W. W. Mein has been appointed consulting engineer for the Dome mines of Porcupine, Ontario. Mr. Mein has had experience in Robinson Deep mine, South Africa, and in the West.

W. L. Affelder, superintendent of the Redstone plant of the H. C. Frick Coke Co., recently made an extended inspection tour through the anthracite region to examine into the various methods employed in the recovery of culm.

C. M. Riker, of the West Kentucky Coal Co., Paducah, Ky., has been appointed assistant to President W. B. Kennedy, of the Nortonville Coal Co., Nortonville, Ky.

Edward S. McKinley, Jr., was killed by a coal car in the Yampa Valley Coal Co.'s mine, at Oak Creek, Colo., in December. He was in charge of the property.

Henry T. Shillingford, president of the Kittanning Coal Co., and for many years widely known in bituminous coal-mining circles, died at the age of 65 while attending a Presbyterian Church banquet.

C. H. Palmer, ex-president Butte & Boston Mining Co., died on December 27, at Atlantic City, N. J.

Augustus P. Barnard, E. M., connected for many years with United States Coast and Geodetic Survey, died in New York City of pneumonia on December 26.

H. K. Christ, of Mahanoy City, Pa., has the contract for the construction of a 500-ton breaker for the Beaver Valley Coal Co., at Scotch Valley, Pa.

Charles Sumner, manager of the Moose Smelting and Refining Co., of Alma, Colo., will spend the next 2 or 3 months at his old home in Birmingham, Ala.

W. H. Blackburn, superintendent of Tonopah Mining Co., Tonopah, Nev., passed the holidays in Denver.

A. H. Brown, one time manager of the Pike Lake mines, of Swastika, Ontario, is now manager of the Temiskaming and Hudson Bay property in Cobalt.

Horace G. Young, former manager of the Temiskaming and Hudson Bay property, has resigned, to look after the development of his interests in Porcupine, Ontario.

W. R. Elliott, manager of the Utah Engineering and Machinery Co., of Salt Lake City, Utah, has returned to his office after spending the month of December in Pittsburg and vicinity.

Bernard P. Manley, formerly inspector of mines for the Colorado Fuel and Iron Co., at Walsenburg, Colo., has opened an office in Denver for the practice of his profession. Mr. Manley will specialize in economic mine management and cost reduction.

George R. Delamater, consulting engineer, of Denver, is at the plant of the Carbon Coal and Coke Co., Cokedale, Colo., investigating the ovens and washeries.

Morgan T. Townsend, district representative of the Ingersoll-Rand Co., has returned to Leadville, Colo., from a month's vacation in the East.

The coal-mine inspectors of the State of Wyoming are George Blacker, District No. 1, Cumberland, and Wm. E. Jones, District No. 2, Sheridan.

Chas. H. Tobey has been promoted to superintendent of the D. L. & W. Coal Co., with headquarters at Scranton, Pa. Mr. Tobey has been connected with the coal mining department of the D. L. & W. Railroad for 11 years, about one-half of the time as chief clerk and the other half as assistant superintendent.

W. F. Rossman, of Caney, Kans., has been appointed general manager of the American Zinc, Lead and Smelting Co.'s smelters.

W. S. Pate has been appointed general manager of the Falls City Lead and Zinc Co., Falls City, Mo.

W. H. Robertson, of Webb City, and B. K. Blair, of Joplin, are meeting with numerous obstacles in the endeavor to rehabilitate the old Kansas Zinc Co.'s smelter at Nevada, Mo.

J. C. Parrish has been inspecting the Mexico-Joplin zinc mines at Thoms Station, Joplin, Mo.

W. H. Loomis has been appointed general manager of the Rockhill Iron and Coal Co., Robertsdale, Huntington County, Pa.

John Evans, for the past 5 years superintendent of the coal properties of the St. Louis, Rocky Mountain & Pacific Coal Co., at Koehler, N. Mex., died suddenly of heart failure Christmas morning. Mr. Evans was about 55 years of age, and one of the best known coal-mining men in the Southwest, having been at various times in the employ of the C. F. & I. Co., both on the western slope and at Berwind, near Trinidad, and was at one time superintendent of the Gray Creek mine of the Victor American Fuel Co. The remains were interred in the Masonic cemetery, Trinidad, on the 28th.

Col. W. S. Hopewell, president of the New Mexico Fuel and Iron Co., and owner of the New Mexico Central Railroad, was stricken with paralysis on December 23, while riding from his ranch in Sierra County, N. Mex., to the railroad to take the train for his home in Albuquerque. Mr. Hopewell was not found until several hours after his seizure and it is feared that the exposure—he being 60 years of age—will result fatally.

W. B. Wise, of New York City, W. C. Corts, of Coffeyville, Kans., and John Cregan, of South Bethlehem, Pa., have been examining and estimating on the cost of starting up the Ozark Zinc Oxide Co., of Joplin, Mo.

W. B. Phillips, former superintendent of D. L. & W. Coal Co., has been promoted to general manager of the same company, with headquarters at Scranton, Pa.

H. S. Hawley, of Spokane, Wash., is now the principal owner of the Della property of the Silver Hoard group, near Ainsworth, B. C.

L. J. Harper, general manager of the Republic and Emperor-Quilp companies, Republic, Wash., announces that "heretofore we have been unable to ship from the intermediate level of the Surprise, because the only railroad which served those workings had no connection with our markets. With the new railroad the output from now on will be between two and three carloads a day, about half of which will go to Tacoma and the other half to the Washoe Sampling Works at Butte."

Albert Ladd Colby, consulting engineer, 165 Broadway, New York, has returned from a 3 months' study of the latest developments in German by-product coke manufacture.

R. J. Young, of the North Chicago works of the United States Steel Corporation, gave an illustrated lecture to the students of the College of Engineering of the University of Illinois, on Decem-

ber 13, in which he described devices for protecting workmen against accident in steel mills.

Charles Of, E. M., one time with MINES AND MINERALS, later in mining practice, and altogether a broadly educated man in mining and metallurgy, is now editor of the *Mineral Industry*.

Marshall Haney, of Geer, Va., has been examining coal lands in Kentucky, Indiana, and Ohio, and on the strength of his reports some large tracts have been purchased which it is intended to develop in the spring.

Capt. W. A. May, former general manager of the Pennsylvania Coal Co. and Hillside Coal and Iron Co., has been promoted to the vice-presidency.

Baird Snyder, Jr., resigned as general superintendent of the Lehigh Coal and Navigation Co. on January 1, and has opened an office at Pottsville, Pa., as a consulting engineer, but will devote most of his time to his personal bituminous coal interests in Virginia and West Virginia.

J. B. Tyrrell, M. A., of Toronto, recently examined the Lucky Cross mine, at Swastika, Can. J. B. Vandergrift, manager of the mine, also issued a report which Mr. Tyrrell for the most part verifies.

W. H. Charlton has resigned as chief clerk and purchasing agent of the Winona Copper Co., King Philip Copper Co., Ojibway Mining Co., and Houghton Copper Co., at Houghton, Mich., and will locate in Detroit, Mich., devoting his time to other work in connection with the mining industry.

James W. Graham has been appointed one of the three deputy coal-mine inspectors of Colorado, vice Harry Douthwaite, resigned. Mr. Graham will make his headquarters in Denver and have charge of the counties of Boulder, Weld, El Paso, and Routt.

The Colorado Scientific Society elected the following officers to serve during 1912: President, George E. Collins; first vice-president, E. N. Hawkins; second vice-president, W. P. J. Dinsmoor; treasurer, John W. Richards; secretary, H. C. Parmelee; executive committee, Professor George L. Cannon, George G. Anderson, term expires January 1, 1915.

B. C. Carpenter has been appointed manager of the Markle collieries, with headquarters at Jeddo, Pa.



Coke Making in Italy

The following notes were abstracted from a paper entitled "The Present State of the Metallurgical Industry in Italy," by L. Dompe and F. S. Pucci, of Milan, which was read at a recent meeting of the Iron and Steel Institute in England.

The coke ovens at the Elba company's plant at Portoferrio, Italy, are of two kinds, namely, retort ovens with and without by-product recovery. The first are arranged in two parallel batteries of 60 chambers each. They are of the Bernard type, with steam coke discharger. Coal crushers supply 500 tons of finely crushed coal per 24 hours, and each oven yields 3 tons of coke in the same time. A mixture of Newcastle and Cardiff coal is used, so as to ensure absence of phosphorus, which would be injurious in the Bessemer converters. The waste gas is used for heating the oven and for raising steam in the boilers.

There are also two batteries of Koppers by-product ovens, one of 40, the other of 60 chambers. They are charged either with loose or with compressed coal, and each oven yields about 4 tons of coke per 24 hours. The daily production thus amounts to 760 tons of coke, which is more than that required for consumption in the three blast furnaces. The excess is stored in case of stoppage for repairs to the ovens, and some is sold.

The gases are collected in a receiver, condensed and cooled for deposition of tar. They are then washed, and the ammoniacal liquors are led off into distilling apparatus and treated with sulphuric acid for the manufacture of sulphate of ammonia, of which 5 tons daily are produced, together with 8 tons of tar.

The Societa' Alti Forni Fondere Ed Acciaierie Di Piombino, at Porto Vecchio, has 74 Otto ovens, producing 400 tons of coke

per day. The equipment includes a coke charger and pusher, the former, which compresses the coal, by means of a worm-gear, into a cake of 10 tons weight, and after 36 hours of coking pushes it out on the opposite side. After recovery of the usual by-products the gas is used partly for heating the ovens and partly for raising steam in Babcock & Wilcox boilers, driving engines aggregating 2,000 horsepower. In 1910 the construction of a new battery of ovens was begun.

The Ilva Iron Co., at Bagnoli, was established in 1904, and has the most modern iron and steel plant in Italy. The works are divided into four sections—coke ovens, blast furnaces, steel works, and rolling mills—besides departments for general service and accessories.

The coke ovens use coal that is either washed small coal of German origin or English coking coal. It is mixed by automatic mixing machinery, according to its composition, and is crushed fine. It is then conveyed to storage bins, each of 500-tons capacity, whence it is readily loaded into trucks. The coal is not compressed before charging, but it can be stamped if desired, by stamping machines provided for the purpose. The ovens are in two parallel lines of 60 chambers each, and the excess gas, mixed with blast-furnace gas, serves for heating the open-hearth furnaces, the reheating furnaces, and for steam raising, a gasometer of 30,000 cubic meters capacity being provided for its storage. The equipment includes two coke pushers to each battery. A by-product recovery plant of special construction also forms part of the installation. The daily consumption of coal is 600 tons, and the production amounts to 480 tons of coke, 10 tons of tar, and 6 tons of sulphate of ammonia



Automatic Switch for Shaft Bottoms

At the Fremont and Rockvale coal mines of the Colorado Fuel and Iron Co. an automatic switch is in use which it is believed was designed by J. Q. McNatt, mining engineer, of Florence, Colo.

The object of the device is to distribute loaded mine cars alternately to the bottom of a double-compartment shaft, and

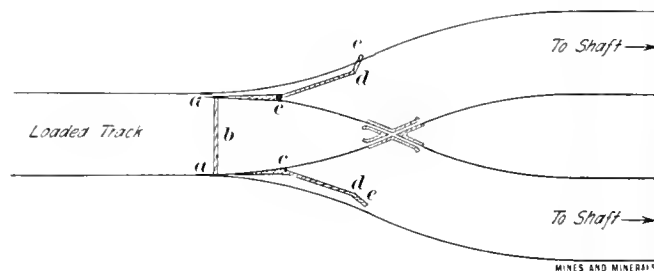

FIG. 1. AUTOMATIC SWITCH

while it is not old it so far has proven successful. By reference to Fig. 1 it will be seen that the two bent arms *a c d e* terminate in the switch points *a* that are bolted to the switch rod *b*, thus causing the three parts to move as one.

The arms are pivoted at *c* and bent in such a manner that the part *d e* of one or the other of them rests on the outer rail of the parting. As the switch is set the loaded mine car will take the track leading to left-hand shaft compartment, and when it reaches the bend of the arm *d e* on the rail will push it in, thereby throwing the other arm over and the bend *d e* on the track leading to the right-hand shaft compartment.

The dimensions given are for a track having 3-foot gauge, and are as follows: From rod *b* to *a*, 6 inches; from *b* to *c*, 2 feet 7 inches; from *c* to *d*, 2 feet 6 inches; from *d* to *e*, 8 inches. The wheel base of the mine cars is 20 inches and of course enters into the calculations for any other track gauge.

Relieving Accumulations of Gas

Use of Bore Holes by Which Gas Under Pressure Was Drawn Off from a Lower Seam

By *W. H. Cunningham, General Manager, and C. R. Connor, Manager of Mines**

The following interesting and valuable paper was read at the Kentucky Mining Institute under the title "Bore Holes for Relieving Accumulations of Gas."

From time to time we hear of some accident due to the sudden release of accumulations of gas in abandoned mines and old workings in active mines. This is usually caused by old workings being tapped unexpectedly by live workings and thereby endangering the lives of many.

There has been but little scientific research into the methods of relieving gas pockets and accumulations and accordingly a very broad field is left open for discussion; however, the writers will confine themselves briefly as to the method of handling one particular situation which came under their direct supervision.

About 4:25 P. M., Saturday, December 11, 1909, a huge column of water was thrown out of the main hoisting shaft at the mine carrying with it the cage which had been at the landing of the No. 12 seam. The column of water was closely followed by smoke and fire, and almost instantly the tibble was enveloped in flames. As far as could be ascertained from eye witnesses there were two explosions in rapid succession, which were heard a little after the flame was first seen shooting up the shaft, and these were later followed by some seven or eight minor explosions. As late as 8:30 in the evening two small explosions were heard.

Immediately after the explosion, relief parties were formed and hurried to the scene of the disaster; the state mine department was notified, as well as neighboring operators, who responded promptly volunteering assistance, and by the time Assistant State Mine Inspector T. O. Long arrived at the mine, a little after 8 P. M., the surface fire was under control, the shaft roped off, and a force of men at work repairing the fan, which had been badly damaged. As soon as the fan was repaired, a rescue party was formed which was joined the next day by Prof. C. J. Norwood, Chief Inspector of Mines, who remained at the head of the relief party until the bodies of the seven unfortunates who lost their lives

* West Kentucky Coal Co.

were removed from the mine. The shaft had originally been sunk to the No. 9 seam, a distance of 211 feet, and after being worked for several years, the mine was abandoned, standing idle for some months and allowed to fill up with water, the shaft also being filled to a point about 96 feet from the top. It was then decided to make an opening in the No. 12 seam in the same shaft a distance of 125 feet above the No. 9 seam, and 86 feet from the top of the shaft. This work was commenced before the writers connection with this company. Fig. 1 is a map of the workings in the No. 12 seam up to the time of abandonment, with part of the workings in No. 9 seam shown dotted, and Fig. 2 is a log of the hoisting shaft. At the time of the disaster the opening in the No. 12 seam had been working nearly 3 years.

In the investigations held by the coroner's jury, county and state mining departments, the coal company and its officials were held absolutely blameless. The state mining department then advised that before any one would be permitted to reenter the

No. 12 seam, it would be necessary, in some manner, to provide an outlet for future accumulations of gas in the No. 9 seam, to enable working in the upper seam with safety.

After thoroughly canvassing the situation, at a conference between Professor Norwood, Mr. Long, and the writers, it was decided that if bore holes could be drilled into the No. 9 seam, it would be the practical means of relieving the situation and would meet with the approval of the state mining department.

The engineering problem which confronted us was not so much the drilling of the holes, but to have them properly tap points near the faces of the three rise headings in the lower or No. 9 seam

and at the same time pass through solid pillars of coal in the upper or No. 12 seam. This is obvious and was deemed of the utmost importance in order to prevent possible leak from the bore-hole casings into the No. 12 seam. The subject of escape of gases from wells into mines was ably presented by C. H. Tarleton, of the Consolidation Coal Co., of West Virginia, in his paper "Mine Explosions From Natural Gas Wells," read at the last annual meeting of the West Virginia Coal Mining Institute.

Old survey records of the No. 9 seam were carefully plotted, and as far as possible, tied with and fitted to surveys in the No. 12 seam. The superimposed map in Fig. 1, shows the nature of this work and the final location of the bore holes marked O 1, 2, 3. We learned from old employes that the workings in the No. 9 seam had given considerable trouble with gases, and we decided that when abandoned it was quite probable that before a sufficient quantity of water had collected to fill all the workings, a consider-



FIG. 1. PLAN OF MINE, SHOWING LOCATION OF BORE HOLES. O 1, 2, 3 BORE HOLES

able amount of gas probably accumulated at the faces of the three rise headings, being held in check there by the pressure of the water standing in the shaft below the No. 12 seam. This was taken under careful consideration and caused the selection of the bore-hole locations as close as possible to the faces of the three rise headings in No. 9 seam, at the same time passing through good-sized pillars in the No. 12 seam. The dip is 3.6 per cent., N 35 E, the three headings being driven directly to the rise.

On December 18, work was started on the bore holes using two ordinary churn-drill rigs. These put down holes to carry 8-inch casing to the rock, ranging from 24 feet in one hole to 80 feet in the deepest. The bits were then changed, reducing the holes to a diameter suitable to carry 6-inch pipe. This was carried to a point 10 feet below the No. 12 seam, then grouted with a mixture of 1 part cement to 1 part sand between the 6- and 8-inch casing up to the surface. This was allowed to stand 48 hours to set. From this point down to the No. 9 seam, 5½-inch holes were drilled, in which 4-inch pipes were placed, the bottom 6 feet of which were perforated in many places to permit the gas at the roof to escape while the ends rested on the bottom. From the surface down to a depth of 10 feet, grout was poured between the 4-inch and 6-inch pipe to prevent gas escaping anywhere except from the top of the pipes which extended above the surface 20 feet. Upon the end of these three 4-inch pipes were securely fastened copper gauze caps or hoods 6 inches in diameter by 6 inches high, 784 meshes per square inch, this mesh gauze being impervious to flame. The average cost per foot of these bore holes, completed, including pipe, grouting, and other material, was \$2.75.

When the holes were near completion, the fires under the drill-rig boilers were drawn and the holes completed by steam furnished from the boiler plant at the mine, this precaution being taken to protect the drillers. There was considerable pressure at the first hole for several hours after the drilling was completed, slight pressure at the third hole, and a noticeable suction down the second hole; however, an increased pressure was noticed at the first hole during the period of suction at the second hole. All three holes were successful in hitting the headings as planned.

At the completion of the drilling an inspection and test of the holes was made by Assistant State Mine Inspector Mr. Long, who also tested with a Pieler lamp around the pillars in the No. 12 seam through which the holes passed. He found the work satisfactory.

As a further precaution, a 3-foot concrete basin was built at the top of the shaft, into which is pumped all the water from the sump, which is the shaft below No. 12 seam, the water being kept to a point 10 feet below the cage landing. This enables a close watch to be kept on all water pumped out in order that any disturbance may be quickly detected. Since the mine has been in operation a watch is kept on the holes to see that they are in working order at all times, and we have found that they have well served their purpose.

It may be of interest to members of this Institute, for the purpose of discussion, to hear several of the theories advanced by mining experts as to the cause of the explosion that necessitated drilling the three holes. Several operators have advanced the idea that the explosion took place in the upper No. 12 seam, a pocket of gas having been ignited by one of the seven men at work. The idea is further advanced that the rush of air after the explosion, in passing up the shaft, caused such a suction as to draw the column of water about 110 feet solid up the 211-foot shaft, releasing the pent-up gas from the No. 9 seam, the opinion being that the gas in passing up the shaft was fired at the opening to the No. 12 seam,

setting fire to the shaft timbering and tibble. A second theory was that air and gas were compressed in such volume that a heavy fall in the lower seam was sufficient to cause the column of water to be ejected from the shaft, followed by gas which expanded through the upper seam and was ignited from the lamps of the men.

A third theory, and the one most generally accepted, is as follows: A large fall or some unusual disturbance in the No. 9 seam caused the ignition of the gas and subsequent explosion at that point, forcing out the water, the seven men in the No. 12 seam being overcome with afterdamp. From the position of the bodies when found, it appears that the men, who were the only ones in the mine at the time of the accident, were on their way to the bottom, having finished work for the day. There was also very little evidence of the explosion in the upper seam, and there were no lights at the cage landing as the generator was not running that day. Hence the third theory seems the most probable of those advanced; particularly so from the fact that gas had never been found in the No. 12 seam in sufficient quantities to cause it to be mentioned in the report of the mine inspector. This is also true since the mine has resumed operations.

It is impossible to have any exact information as to the origin of the explosion; however, it has been demonstrated that the use of the bore holes has proven successful, permitting the uninterrupted operation of the No. 12 seam.

采采

Book Review

MINING WITHOUT TIMBER, by Robert Bruce Brinsmade, B. S., E. M. The rapid depletion of forests in America has raised the price of timber so rapidly the mining industry is becoming alarmed as to its future supply. Economy in the use of timber has been essential to commercial success in European mining for several generations, and it was to the Old World that our operators went for their first systems of timberless mining. The practice described in this book is mostly from North America, Australia, and South Africa. In all there are 303 pages, 9 in. x 6 in., divided into 23 chapters, with 146 illustrations and index. Mr. Brinsmade has traveled extensively, has been a close observer of matters relating to mining and metallurgy, and is a capable writer, as the back volumes of *MINES AND MINERALS* will show. One error, however, we notice in the first paragraph of Chapter XXI. The author there states that the flushing system was first developed in 1891 at the Dodson mine, near Wilkes-Barre, Pa. As a matter of fact it was first used by Frank Pardee, E. M., at the Hazleton No. 5 mine of A. Pardee & Co., at Hazleton, Pa., in 1885-86, and on a more extensive scale by the P. & R. C. and I. Co. at the Kohinoor colliery, Shenandoah, Pa., in 1887. The book is printed by McGraw-Hill Book Co., New York City, its price being \$3 net.

MODERN PRACTICE IN FUEL CONTRACTS, by Myles Brown, M. E. Published by *The Science and Art of Mining*, Wigan, England. The object of this book is to place at the service of those who buy and sell fuel the best modern practice in fuel contract notes, and to provide information to contracting parties, which will enable them to adopt specifications that are indispensable to the construction of a scientific and commercially sound contract note. There are 125 pages 8½ in. x 5½ in., divided into 10 chapters with index. Price, 4 shillings. The book is practical and shows how to purchase coal and make contracts. It treats on the comparative values of coal; their classification; and on briquets; gives calorific formulas and much other useful information. While the book deals with conditions in Great Britain more particularly, as out-

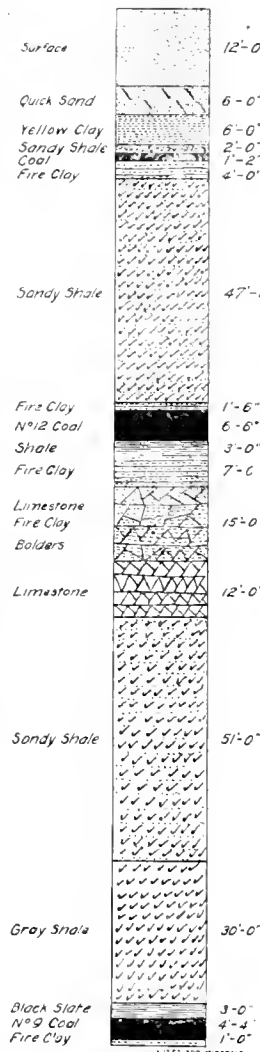

FIG. 2. SECTION

lined it should be helpful to Americans engaged in the coal industry.

THE VENTILATION OF MINES, by R. A. S. Redmayne, His Majesty's Chief Inspector of Mines, is the fourth volume of the Modern Practice in Mining by the same author. This book contains 231 pages 5½ in. × 8½ in., with 210 illustrations and two folders. It is intended for mining students, is practical, not given to romancing, although there is some ancient history and quite a few rather indefinite statements, the author evidently believing the subject not proven to an extent that would warrant making his text absolute. The nine chapters into which the book is divided touch upon nearly everything pertaining to mine ventilation, although but a little more than six pages is given to "dust explosions," while 11 pages are given to the early forms and now obsolete methods of producing a ventilating current. The book is a good one and well worth the \$2.10 asked for it by Longman's Green & Co., publishers, New York City and London.

A. H. Ricketts, Esq., of San Francisco, has written a book on mine laws of the United States, Alaska, and the Philippines. The title of the book is "RICKETTS ON MINES." It contains about 500 pages and will undoubtedly be of use to those interested in United States mineral land laws. In a casual glance at the index the term "Blanket Sluice" is noted. If the reader wonders what a blanket sluice has to do with law he will find on examination that it has nothing whatever. However, he will find the word "sulphurets," which T. A. Rickard said is employed by people who ought to know better; also the words "tailings" and "concentrates," the use of which Mr. Rickard calls a bad habit, and moreover, a Mormonism of style. Lawyers, like poets, take unlimited license with the English language; for instance, ore is defined as a compound of metal and some other substance, when it should be "any mineral that can be worked at a profit." It is certainly a pity a book of this description could not be edited by a mining engineer before being given to the public. In order to make section 99 scientifically correct it would be necessary to tear it piecemeal. However, it is sufficiently correct for lawyers, who need something for argument, and the definitions are judges' interpretations, based on what they don't know. Scientific Publishing Co., San Francisco, Cal., publishers

The second edition of WALLS, BINS, AND GRAIN ELEVATORS, by Milo S. Ketchum, C. E., Dean of the College of Engineering, University of Colorado, has been issued by the McGraw-Hill Book Co., of New York. This is a standard work on the design of walls, bins, and grain elevators. that will be helpful to designers of ore and coal bins, mills, tipples, breakers, and similar structures. There are three parts and an appendix. Part I treats on The Design of Retaining Walls; Rankine's Theory; Rankine's Theory Modified; Coulomb's Theory; Reinforced Concrete Retaining Walls; Effect of Cohesion; Stresses in Bracing Trenches; Stresses in Tunnels; Experiments on Retaining Walls, and Methods of Construction and Cost of Retaining Walls. Part II refers to The Design of Coal Bins, Ore Bins, etc.; Stresses in Bins; Experiments on Pressures

on Bin Walls; Examples and Details of Bins; Cost of Bins; and Methods of Handling Materials. Part III is on Grain Bins; Grain Elevators; Stresses in Grain Bins; Experiments on the Pressure of Grain in Deep Bins; Design of Grain Bins and Elevators; Cost of Grain Bins and Elevators; and Examples of Grain Elevators. Appendix I has four chapters on Concrete, Plain and Reinforced. This book is suitable for students and engineers, as it combines theory with practical examples and cost data. There are 556 pages 6 in. × 8½ in., 266 illustrations, suitable tables, in fact nearly every kind of data pertaining to the subjects covered. Price \$4.



Mine Management Diagram

By Edwin Ludlow

The question of distribution of mine management varies amongst different mining companies, as it does in various railway systems, and in some cases certain heads of departments report to the general superintendent, in other cases they report direct to the general manager, and men are sometimes placed directly under the master mechanic, and in other mining companies, under the superintendent. This always creates more or less confusion with men passing from one mining company to another, and in order to define the matter it has been found to be advantageous to get out a management diagram to be posted in the various offices of the heads of departments, so that each man can find exactly to whom he is immediately responsible.

I enclose a form of the diagram in use at the New River Collieries Co. and it has been

accepted by all of the men as being very advantageous to them in avoiding any question of direct authority or responsibility. The full line shown on the diagram represents direct authority, while the dotted line represents indirect authority in regard to other portions of their work.

For example, the weighman and timekeeper, while working under the authority of the local superintendent, have to make their reports to the pay-roll clerk, who is under direct charge of the auditor.

The underground mechanic looking after the pumps and mining machines has direct charge of the pumpmen, motor men, and machine runners, and works himself directly under the authority of the mine foreman, who instructs where the work shall be done and how it shall be done.

The responsibility for the machinery under his charge is represented by the dotted line to the master mechanic, who holds the underground mechanic responsible for keeping up his machinery in good working order. The pumpmen, motormen, and machine runners are also subject to the electrical engineer, as shown by the dotted line, for keeping their electrical machinery in good working order. Thus the relation of each man to the whole organization is evident.

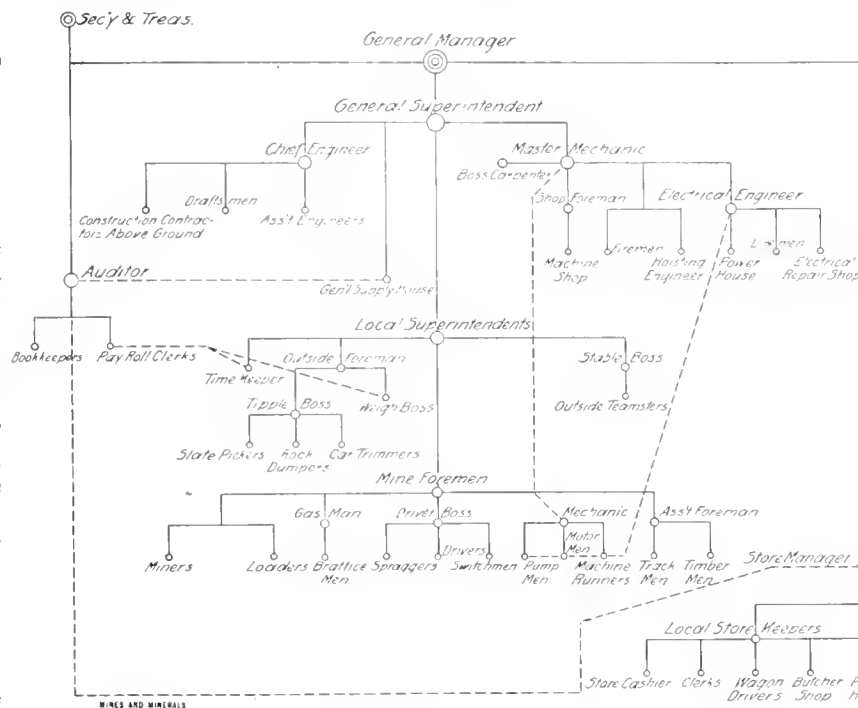

MINE MANAGEMENT DIAGRAM

Workmen's Liability Insurance

The Cost, and Who Shall Pay It—Relative Dangers of the Different Industries

By C. O. Bartlett*

The following article is abstracted from Mr. Bartlett's paper on "Workmen's Liability Insurance," which he read at the Chicago meeting of the American Mining Congress:

During the last year much has been said about workmen's liability insurance, and a number of states have enacted laws pertaining to this important question. The bone of contention is: Who shall pay the bill? It is certainly very nice for every workman in a mine, factory, or on a farm to have a workmen's insurance policy, and especially would this be true if somebody else paid the premium.

There seems to be a sort of general opinion that insurance companies are robbers, that they have made vast fortunes out of the employers' insurance business, and if the state or general government would go into this business, the rate would be very much less. Now the true facts of such matters, judging from the past, are that all business done by a city, state, or general government costs nearly twice as much as when done by private corporations or individuals, and we see no reason why there should be any variation from this general rule in the insurance business, and I think it is fair to assume that when any state, or the United States as a whole, gets into the liability insurance business, the cost will increase the same as it has done in other lines, and the idea that a lot of money will be saved is only a myth.

In taking up the question, we should consider most carefully, that where there is one large mining corporation, there are hundreds of smaller ones, and I wish to speak especially to these medium-sized corporations or companies. The large companies like the Philadelphia & Reading Coal and Iron Co., the United States Steel Corporation, the Pittsburg Coal Co., the Standard Oil Co., the International Harvester Co., and some others control largely the selling prices of their products; in other words, when they say thumbs up, up they go, and when they say thumbs down, down they go, but the medium-sized companies, with competition on every corner, cannot do this, and if we add to the expense of these companies, even at the rate of 1 per cent. a year on capital stock, it will mean just as sure as the sun will rise tomorrow that thousands of them will go to the wall.

To illustrate this: Two years ago the state of Ohio, which is one of the largest manufacturing states in the Union, one of the best located for manufacturing purposes, with plenty of cheap coal, with cheap iron ore, the best of water and rail transportation facilities, the best of farming lands from one end to the other to supply bread and meat, and perhaps more natural advantages than any other state in the Union, put a special tax of $\frac{1}{10}$ of 1 per cent. on all corporations, and last year they increased this by 50 per cent., making a yearly tax of $1\frac{1}{2}$ mills on every dollar of the capital stock. In other words, a company of \$60,000 capital stock is now compelled to put into the state treasury as a special yearly tax \$90 per year. This may seem like a small amount, but last spring more than 1,200 of the Ohio corporations were delinquent in this special tax, the delinquency amounting to more than \$2,000.

To further illustrate, if a tax of 1 cent a ton were put on all coal mined in the United States, it will mean very nearly 1 per cent. on the selling price of all the coal mined in the United States, and according to Mr. Parker the output of coal in the United States in 1910 was 501,000,000 tons, and at 1 cent a ton means over \$5,000,000. I do not hesitate to state that the 33,000,000 tons of coal mined in the state of Ohio last year did not pay dividends to the owners of the mines of more than 2 per cent., and a tax of 1 per cent. would mean ruin.

According to this same report by Mr. Parker, the average price of bituminous coal is a little over \$1 a ton. Now then, it has

* Cleveland, Ohio;

never been estimated by any actuary that the workmen's liability insurance tax against any mining or other company would be less than this amount, and probably it would be more, possibly 200 per cent. more; in fact, we are told by insurance companies that it will be fully this much, and, at any event, so important a measure as the workmen's liability insurance should receive the most careful consideration.

When we look at the question thoughtfully, it means that all workmen in mines will have a liability insurance policy so that in case of accident they shall draw a certain amount a week, say 60 per cent. of their wages: that in case of death their families will draw a certain amount a week up to a certain maximum, say \$3,000 or \$4,000.

It is certainly a good thing for each workman to have an insurance against injury or death, but who should pay the bill? Naturally the workmen are anxious for the employer to pay the premium, and naturally the employer is somewhat loath to do it. We must not forget the fact that over 80 per cent. of the men engaged in business, mining, or other kinds of business, do not meet with success. Again, I wish to say, to the miners and manufacturers, that if it is legal to insure the workman in the mines and factories throughout the cities and towns, it is equally as important to the workmen on the farms.

There seems to be a prevailing idea that mining is a dangerous occupation, yet statistics show that mining is far less dangerous than a large number of manufacturing industries. By statistics given by the government, it is found that in Pennsylvania mining is about one-thirtieth as dangerous as making nuts and bolts. It is not more dangerous than railroading, and only half as dangerous as farming. By such statistics as can be had in this country and in Germany, more than 45 per cent. of all the accidents happen on farms, and there is no question whatever in my judgment but what farming, as it is carried on at the present time in the United States, with its improved machinery, is far more dangerous than mining. Now, if it is necessary to protect the mine worker, why not protect the men on the farm, and any law that protects one without protecting the other should never be sustained by any court.

Very much is being said about the high cost of living. You cannot expect the boys to remain in the country and work 12 hours a day for \$1.50 when they can get two or three times this amount in a mine and work 6 or 8 hours a day. Now if we throw in an insurance policy besides, it will add to the burden.

All manufacturers of the United States are very much interested in this question, and I feel that I am expressing the majority sentiment of the manufacturers of Ohio when I state that they do not feel as though they should pay the premium. It seems to me that the only fair way to do this is for the employer to pay half and the employe pay the other half, and let the general government, either state or national, bear the expense of the burden of carrying out the provision of the law.

The true object of a liability insurance should be to prevent accidents, and from an experience of many years I feel absolutely confident in making the assertion that if any mine or factory insures its employes and pays for the entire insurance, the number of accidents will increase very rapidly; but if you say to the workman, you pay half of the cost and I will pay the other half, then you will have prevented to a large extent all accidents, for the reason that the workmen will be equally as interested and will try in every way to prevent accidents as well as the employer.

Another, and one of the most important matters connected with liability insurance, is that this will bring the employer and employe to a close and friendly relationship, and that is one of the great questions, for both are in the same boat and should work in harmony.

Very much has been said about the splendid laws regarding liability insurance in the old countries, especially Germany. One would almost believe by hearing some of the addresses and by reading some of the articles of the magazines that Germany was almost a paradise to work in, but like all other questions, there are pros

and cons, and of the cons we do not hear so much. They do not state that the taxes in Germany are two and sometimes more than four times as much as they are here; that is, the direct tax; and then there is another tax in this great Germany, a tax that is far more mighty than dollars and cents, and that is that every boy must be taken from his home and devote 5 years of his life to the army. Just for a moment consider what his tax would mean to you and to me. Just as your boy or mine is ready to enter college, how would you like to have the government step in and say: Here Charlie or William, you come with me for 5 years; I want you, and he has to go. Now then, if an observing man knows anything, he knows that army life is very bad for a young man, and I am told by good authority, by some of the men who have been through this army in Germany, that many of the good moral boys, in fact the majority, that enter the army come out very bad men at the end of their term, and I say right here that if there is any one thing that I am thankful for, it is that we do not live under such laws as they have in Germany.

But let us go a little further into these good laws of Germany. One would almost be led to believe that many workmen would immediately go to work under these favorable conditions, but how many mechanics from your town left for Germany last year? I venture to say that you would count the number on your four fingers, and I can furthermore venture to say that then you can divide it by four, and in many cases you can subtract one from this amount. On the other hand, how many of the workmen from that country have come to this country to better their conditions? Over 180,000 German people came here last year, and they have bettered their conditions, and we are

glad to have them here. In Germany the employers only pay one-third of the cost, and I repeat that we should consider, and consider most carefully, before we burden our mining operators and manufacturers with the tremendous cost of workmen's insurance.

采 采

Shaft Bottom at the Arenberg Mine

This third of a series of articles on Shaft Bottoms was abstracted from L. Saelier's article that appeared in *Revue Universelle des Mines*, August, 1904.

At the Arenberg mine, in France, two coal beds, one at a depth of 722 feet and the other at a depth of 1,108 feet, are worked simultaneously. The beds have an inclination of about 30 degrees and are reached by two circular shafts, one the main shaft 16.4 feet in diameter and the other, the air-shaft, 12.5 feet in diameter. The main hoisting shaft has two cages, each with three decks and each deck has room for four mine cars of 1,320 pounds capacity, on two tracks. For a maximum output of 1,650 tons per day, 2,512 mine cars must be hoisted, consequently the movement of the cars on, off, and to the cages must proceed with precision and regularity. With this end in view, the shaft bottom shown in Fig. 1 was planned.

In the illustration *a* is the main hoisting shaft, *b* the upcast, and *c* an inside shaft or winze from the upper to the lower coal seams. Although the two coal beds are worked simultaneously, it is customary to keep the lower workings about 1,000 feet in advance of the upper, to be sure that faults or rolls will not influence the positions of the haulage roads relative to each other. The inside shaft *c* has a gravity hoist with two cages, one of which carries two loaded mine cars from the upper to the lower level, and when so doing raises two empty cars on the other cage. All coal is thus carried to the shaft bottom *a* in the lower level and raised from there to the surface, unless it should happen that the gravity hoist *c* broke down, in which case coal could be hoisted from the landing in the upper bed through the main shaft. Ordinarily, a single loading station considerably increases the capacity of a shaft and does away with the accidents that almost invariably accompany the use of several loading stations in a shaft.

In the illustration the dotted lines represent the upper workings and the heavy line the shaft bottom, but the arrangement about the shaft in the upper level is similar to that in the lower level. As the loaded cars reach the lower level through shaft *c* they run down grade to the cage, while the empty cars run down

grade from the empty track to the gravity shaft. Owing to bad ground, large openings at the shaft bottom were almost impossible and it will be noted that double tracks are restricted to the immediate vicinity of the shaft.

It will be observed that the loaded cars all go down grade to the shaft and that arrangements are complete for keeping the loaded and empty cars separate and practically traveling in circuit. The roads are graded so that advantage may be

taken of the action of gravity, thus all loaded cars are run by gravity to the cages and empty cars are moved by gravity from the cages.

This arrangement prevents congestion of traffic and permits a large number of cars to be handled with comparative ease. On the gravity hoist at *c* two cars are carried on a single deck, and the caging of the loaded cars and the running off of the empties is done automatically with the assistance of gravity and one man. The cages of the main shaft are received at the bottom on hydraulic chairs which stop successively the three decks before the cars can be run on or off.

The three decks of the cage are horizontal when hanging in the shaft, but by a system of levers they are tilted slightly at the landings. Another system of levers holds the cars on the cage until it is desired to have them run off and then empty cars or loaded cars, as the case may be, replace them. With this system the topman and one assistant gets 12 empties in position, while two foot-men distribute the loaded cars on the tracks leading to the cages. One man can quickly run 12 cars off the cage and run 12 cars on, while it takes two men to place the cars in position for the cagers. By this arrangement the coal is quickly and economically handled.

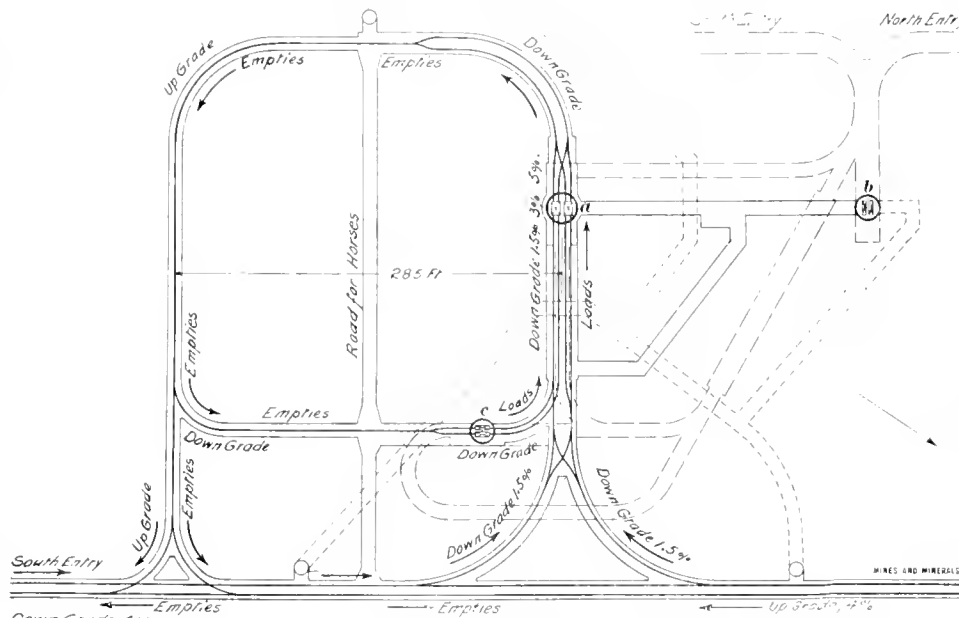

FIG. 1. PLAN OF SHAFT BOTTOM AT ARENBERG MINE

First Mining School in England

During Queen Victoria's Jubilee in 1887, the *Newcastle Courant* reproduced a copy of the *Newcastle Courant*, published at Newcastle-upon-Tyne, England, November 26, 1712, and from it is taken the first advertisement (reproduced on this and the following page), of probably the first English mining school on record.

MINES AND MINERALS is indebted to William Clifford, E. M., of Jeanette, Pa., who it will be remembered introduced the Capel and afterwards the Clifford fans in this country, for allowing it to be reproduced.

As an advertising lesson it is a classic, and as an educational proposition it shows speed for its time; however, according to the adage that there is nothing new under the sun, we must assume from George Agricola's book, that mining schools had previously started on the Continent around the year 1500.

采 采

Spontaneous Combustion of Coal

Influence of Chemical Composition of Coal—Storage Conditions That Tend to Avoid Ignition

The following is an abstract from a paper presented before the joint meeting of the American Chemical, American Electrochemical, and Chemical Industry societies in New York city, on "Deterioration in Storage and Spontaneous Heating of Coal." The paper is a joint one prepared by Horace C. Porter and F. K. Ovitz, chemists, who are connected with the Federal Bureau of Mines and is of such importance it will appeal to every coal man, although every coal man will not agree with their findings.

Losses in coal due to spontaneous heating are a serious matter. Oxidation, i. e., probably in the main an absorption of oxygen by the unsaturated chemical compounds in the coal substance, begins at ordinary temperature in any coal, attacking the surfaces of the particles, thus slowly developing heat. In a small mass of coal this slowly developed heat can readily dissipate itself by radiation and no rise in temperature results. If radiation is restricted, however, as in a large pile densely packed, the temperature slowly rises. Now, the curve of oxidation rate plotted against temperature, rises with great rapidity, and when the storage conditions are such as to allow a certain point (near 100° C.) to be passed, the rate of oxidation is great enough ordinarily so that the heat developed overbalances the heat radiated and the temperature will rise to the ignition point if the air supply is adequate. The importance therefore can be seen of guarding against even moderate heating in the coal either from internal spontaneous causes or by radiation from external sources. Increased loss of heating value and of volatile matter occurs at moderately increased temperatures even though the ignition point is not reached.

The amount of surface exposed to oxidation in a given mass depends on the size of the particles and increases very rapidly as the fineness approaches that of dust. Dust is therefore a dangerous thing in a coal pile, particularly if it is mixed with larger sized coal which forms air passages to the interior. Spontaneous combustion is brought about by slow oxidation in an air supply sufficient to support the oxidation but insufficient to carry away all the heat formed. There is a wide variation among coals in friability. In comparative rattler tests under certain standard conditions, Pocahontas, New River, W. Va., and Cambria County, Pa., coals produced nearly twice as much dust (through $\frac{1}{8}$ -inch screen) as a sample from the Pittsburg seam. This is a large factor in spontaneous combustion. Mixed lump and fine, i. e., run-of-mine, with a large percentage of dust, and piled so as to admit to the interior a limited supply of air, make ideal conditions for spontaneous heating.

High volatile matter does not of itself increase the liability to spontaneous heating. A recent circular letter of inquiry on spon-

aneous combustion sent by the Bureau to more than 2,000 large coal consumers of the United States has brought 1,200 replies, of which 260 report instances of spontaneous combustion, 220 of them naming the coal. Of these 220, 95 are in semibituminous coals of the Appalachian region, and 55 in western and middle western coals. This result shows at least no falling behind on the part of the "smokeless" type and no cause for placing special confidence in these coals for safety in storage.

A serious fire in cinder filling under a manufacturing plant in Pittsburg was recently investigated by the Bureau, and all the evidence pointed to spontaneous combustion as the cause, induced by external heat radiated from a furnace. The cinders contained 40 per cent. of carbon. A similar fire occurred 2 years ago in cinder

[10]

W *Hereas the Knowledge of Mechanicks may be generally useful to all Sorts of Persons, but especially to Gentlemen concerned in Collieries and Lead-Mines; by enabling them, To examine and improve the Engines and Methods, commonly used for drawing their Coals and Lead Ore, and clearing their Pits of Water; As likewise, to form a certain judgment of any new Contrivance, invented by themselves and others for these Services, which will prevent their being imposed upon by Pretenders to Perpetual Movements, and other vain and deceitful Projects; It is hoped that the following Proposals, for an evident and publick Good, will meet with suitable Encouragement, from a Country, to which a design of this Nature may be of greater Service, than to any other Part of the Kingdom.*

PROPOSALS

*For carrying on by Subscription
A compleat Course of Mechanicks.*

BY which Gentlemen, unacquainted with any Part of the Mathematics, in the Space of twelve or eighteen Months, by meeting three Times a Week for an Hour at a time, may be enabled to compute the Effect of any Machine whatsoever, or to solve any other Problem of the like Nature.

That the Course consist of

1. So much of the Principles of Geometry, Arithmetick, and Algebra, as shall be necessary for this undertaking.
2. The general Laws of Motion, and the Principles of Mechanicks deduced from them.
3. The Doctrine of Percussion, or the Effects which follow from the Stroke of Bodies upon one another.
4. The Natural Motion of all heavy Bodies.
5. The Motion of Bodies upon inclined Plains.
6. The Theory of all Kinds of Engines simple and compound, with a par

filling under a smelting plant on Staten Island in which case the cinders contained 33 per cent. carbon. Damage amounting to \$20,000 was done. The cause was not definitely determined, but from the reports of the insurance adjusters spontaneous heating appears to be the most plausible explanation. The volatile matter in the material could not have been a factor in these causes.

Pocahontas coal gives a great deal of trouble with spontaneous fires in the large storage piles at Panama. It is reported also by several large by-product coke concerns to be more troublesome in this respect than their high volatile gas coals. The high volatile coals of the West are, to be sure, usually very liable to spontaneous heating, but they owe this property to chemical nature of the substances which compose the coal rather than to the amount of volatile matter. Strange as it may seem, a high oxygen content in coal appears to parallel its avidity for oxygen and to promote therefore its tendency to spontaneous combustion.

The influence of moisture and that of sulphur upon spontaneous heating of coal are mooted questions much discussed, not very much actually investigated, and certainly not yet settled. Richters has shown that in the laboratory dry coal oxidizes more rapidly than moist, but the weight of opinion among practical users of coal is that moisture promotes spontaneous heating.

The observation by the Bureau of many actual cases has not

[II]

particular Explication of the Engines used in Collieries, and the Method of Examining their Advantages or Defects.

7. Hydrostatics, under which Head will be demonstrated by Experiment; The chief Properties of Water and other Fluids; as, That their Pressure is directed not only downward, but sideways, and upward; That this pressure is always Proportional to the Perpendicular Height of the Fluid; The Method of Calculating the Weight or Pressure of Water against the Banks of Rivers, or Milldams, the Gates of Sluices, Sides of Pipes, and other Surfaces, and consequently determining the Strength requisite for those Bodies to support the Pressure; The Explication and use of the Hydrostatical Balance, in finding the Specifick or Relative Weights of Bodies, and by this Means discovering the Adulteration, either of solid Substances, as of Money, Jewels, &c. or of Liquors.

8. Pneumatics, The Weight and Spring of the Air, it's Rarefaction and Condensation, It's density and spring demonstrated to increase in Proportion to the Force that Compresses it. The Air-Pump, and Condenser, together with the Barometer, Thermometer, Hygrometer, or the Instruments for measuring the Weight, the Heat, and Moisture of the Air, their Nature and Uses explained. The Effects of the Air applied to Mechanical Uses in Pumps, Syringes, Siphons, Engines for quenching Fire, &c.

9. Hydraulicks, or the Doctrine of Water and other Fluids in Motion. The Method of estimating the Swiftnes of Water running in any Canals open or closed, as in Rivers, or Mill-races, Drifts, Pumps, Conduit Pipes, &c. with the Quantities of Water that they Discharge. A particular Application to the draining of Collieries in determining the Quantity of Water carry'd off by any Engine in a given Time, or the Time requisite for carrying off any Quantity of Water by an Engine given; as likewise the force to be applied to any Engine, and the requisite proportion of the several parts of the Machine, for drawing off any Quantity of Water in a certain time, or for clearing and keeping a Colliery clear of Water. Of the Force of Fluids, as Air, or Water, to carry about the Sails or Wheels of Mills and other Engines, and the best proportion of the Machines driven by them, or by Horses.

10. Lastly, The Important Theory of the Friction or Rubbing of Machines, with the Impediment caused by the stiffness of the Ropes, for want of which the greatest Engineers have been disappointed in their undertakings, and the best concerted Machines have been rendered useless. As this has been lately set in a clearer light by the Experiments and Discourses of several Members of the Royal Academy of Sciences at *Paris*, it will be explain'd in an easy manner, partly by Experiment, and the Application of it to the Calculation of Machines will be Demonstrated.

That

[12]

That the Number of Subscribers do not exceed 10, or 12 at the most; And that after all have Subscribed, such proper Hours for their meeting be agreed on, as may be for their general Convenience.

That every Gentleman intending to be present at the Course, pay upon Subscription 2 Guineas, and afterwards half a Guinea a Month.

Which it is hoped, considering the very great charge of the Apparatus for Experiments, and the Labour of compiling and digesting the Course, cannot but be thought highly reasonable, being but half the lowest Rate of Private Teaching Mathematicks in *London*, tho' without any Experiments.

Gentlemen already Qualify'd with Geometry and Algebra, may Subscribe only to the Mechanical and Experimental part of the Course on the same Terms. The Hydrostatical and Pneumatical Experiments alone, may be seen for Two Guineas.

Any other Gentleman, not engaging in the Course, that out of a publick Spirit, shall be pleas'd to Contribute any thing to the Charge of so useful an Undertaking, shall have his Benefaction thankfully acknowledged, and shall at any time be welcome, to see what Particular Experiments he pleases.

Subscriptions will be received by the Undertaker, James Jurin, Master of the free Grammar School in Newcastle, or by Mr. Jaspar Harrison, at his Coffee-House on the Sand-Hill.

developed any instances where moisture could be proven to have had such an effect. Sulphur on the other hand has been shown by these investigations to have, in most cases, only a minor influence. In a number of actual cases, samples of the heated coal from areas where the heat was greatest have been analyzed, both for the total sulphur and that in the sulphate form. The difference between these, or in other words, the unoxidized sulphur, was in no case less than 75 per cent. of the average total sulphur in the original. In other words, not more than one-fourth of the total sulphur has entered into any heat producing reaction. The possibility remains, however, that all of the sulphur which was oxidized was concentrated in one pocket of moist flaky pyrites, and thus sufficient heat was developed in one spot to act as an igniter.

On the other hand, there is the case of a Boston company, using Dominion (Nova Scotia) coal of 3 to 4 per cent. sulphur, that has much trouble with spontaneous fires in storage, but a number of samples taken by the Bureau from exposed piles of this coal in which heating had occurred, showed that 90 per cent. of the sulphur was still unoxidized.

Experiments in the laboratory, passing air over coal at 120° C. have developed enough heat to ignite the coal and no change was found in the form of the sulphur. While not entirely conclusive, these results point to a very minor contribution, if any, on the part of sulphur to spontaneous heating in coal.

Freshly mined coal, and even fresh surfaces exposed by crushing lump coal, exhibit a remarkable avidity for oxygen, but after a time become coated with oxidized material, "seasoned" as it were, so that the action of the air becomes much less vigorous. It is found in practice that if coal, which has been stored for 6 weeks or 2 months and has even become already somewhat heated, be rehandled and thoroughly cooled by the air, spontaneous heating rarely begins again. A large power plant in New York crushes its coal to pass a 4-inch screen immediately after unloading from barges, the fines and dust, 50 per cent. or more, being left in the coal to be stored. This freshly crushed coal is elevated to iron hopper-shaped bunkers directly over the boilers and the air temperature in these often reaches 100° F. As the coal hangs on the sloping sides sometimes 3 or 4 months at a time, it seems hardly surprising that some of the bunkers are on fire practically all the time.

With full appreciation of the fact that any or all of the following recommendations may under certain conditions be found impracticable, they are offered as being advisable precautions for safety in storing coal whenever their use does not involve an unreasonable expense:

1. Do not pile over 12 feet deep nor so that any point in the interior will be over 10 feet from an air-cooled surface.
2. If possible, store only lump.
3. Keep dust out as much as possible; therefore reduce handling to a minimum.
4. Pile so that lump and fine are distributed as evenly as possible; not as is often done allowing lumps to roll down from a peak and form air passages at the bottom.
5. Rehandle and screen after 2 months.
6. Keep away external sources of heat even though moderate in degree.
7. Allow 6 weeks "seasoning" after mining before storing.
8. Avoid alternate wetting and drying.
9. Avoid admission of air to interior of pile through interstices around foreign objects such as timbers or irregular brickwork; also through porous bottoms such as coarse cinders.
10. Do not try to ventilate by pipes as more harm is often done than good.

Hoisting by Electricity

By J. J. Barnes*

Great attention is being given by English colliery engineers to the prevention of accidents during the winding of men in the pit shafts, as during recent years several accidents resulting in loss of life have occurred. The opinions and experience of English experts on the subject may be interesting to American readers. It seems remarkable that serious accidents are not more frequent, taking into consideration all the surroundings, the great speed of the winding, the depth of the shafts, and the small clearances between the cages as they pass and repass each other. A comparison between English and other European practice may be of interest, as these accidents are sufficiently frequent and serious. The essential difference between English and Continental practice is that the former depends on the use of steam engines, whereas the latter is very generally dependent on electricity, not only for winding, but for other colliery work.

There are no doubt a few electrical winding engines at work in England and several have during the last two or three years been provided in the South Wales colliery district, but taking the country as a whole, the steam engine holds its own and colliery engineers hesitate to recommend a change. This cannot be ascribed to ignorance of what has been done elsewhere, as many English mining engineers have paid collective visits to foreign mines for the special purpose of studying some of the numerous electrical winding plants which have been erected in Germany and France. On the continent most of the recent and larger pits have been electrically equipped.

Ease and certainty of control are the essential advantages of electrical winding. Steam winding engines are large powerful mechanisms with heavy moving parts and they are relatively difficult to control. Moreover the speed is low, the cylinders are of considerable diameter to develop the required power and in consequence of the slow speed there is considerable variation in the angular velocity of the cranks; the drum has a varying turning movement, resulting in unsteadiness of the ropes.

The difference between the control of the steam engine and of an electrical equipment is considerable, the former throws a great and continual strain on the acting engineer; he has to work a throttle valve, reversing lever, and a foot-brake, by means of large and heavy levers; the safety of the winding depends entirely on his attention, for no mechanical control gear has been produced sufficiently reliable to merit general approval. It is necessary for the engineer to watch the depth indicator, to attend to the bell and to work the levers controlling the engine, and he makes the reversing gear act as a brake. In comparison, the electrical winding gear is simple and is easily controlled by dealing with the small exciting current of the generator field instead of with the heavy currents in the armatures of the winding motors. Two small levers provide for all requirements, one controls the winding motor and another brings the brake into action. The engineer determines the direction of the wind by pulling the control lever toward himself or pushing it from him. The two levers (control and brake) are of course interlocked so that the latter is released when the former is operated and the winding commenced.

A mechanism has been devised, which makes it impossible for the engineer to exceed a given speed, when the lower speed is required for winding men, which should always be less than that used for winding coal. The electrical equipment includes a combined depth indicator and an automatic safety gear, the latter prevents the engineer starting too quickly. Should the engineer forget to apply the brakes at the end of the wind or to bring the control lever to the "off" position, these operations are automatically done for him. As a further precaution, a special emergency brake is provided, actuated by air pressure, with the object of holding the brake off as long as everything is working as required. Should, however, the pressure fail or

* Manchester, England.

should the bank be overrun, the emergency brake automatically applies itself and cuts off the current from the winding motor. This gear does not depend on electricity, it is therefore safe and reliable as it cannot fail; as long as the electrical equipment is in complete working order the winding gear can be controlled in the ordinary way, but should anything fail, say the supply of current or should anything occur to the engineer, the emergency brake would come into action at once as the power controlling it is gone and the force of gravity would apply the brake.

A motor generator provided with a heavy flywheel and one or two motors directly coupled to the drum shaft make up an electrical winding gear; the work done in accelerating or retarding the load is to a considerable extent saved as the power used for acceleration at the commencement of the winding is largely regained during braking, but with the steam engine this is energy lost. Again, during braking the winding motor acts as a generator as it absorbs the power given off by the moving masses during retardation and reconverts it into power and stores it in the flywheel of the motor generator.

The first cost of an electrical winding equipment is a heavy one; it is therefore more applicable for new collieries than as an alternative for steam in existing ones.

采 采

Quick Tape Repair Bands

In the December number appeared an article by J. A. Smith, E. M., on "Repairing Broken Steel Tapes." Since then the following remarks on quick tape repair bands have been received:

William Archie Weldin, C. E., of Pittsburg, writes: "Mr Smith's article reminded me of my father's efforts to secure a simple and reliable device adapted to field repairing of tapes. In his practice he frequently had a number of full corps surveying at points often distant from any railroad, and the expense and delays due to broken tapes proved very serious, even though extra tapes and cumbersome repair outfits were carried constantly. After trying several devices he developed a mender which required few accessories and gave an accurate and strong splice which would not cause new breaks, catch when dragged along the ground, or tear the hand. The splice which he patented is shown in Fig. 1 (b) and is used as follows:

"The broken ends of the tape are inserted from opposite ends of the clip and rest on the central portion *a* which is bent down. The end flaps *b* are then bent down firmly on the tape with a hammer, and finally the long flap *c* is bent down over all. No tools are required to be carried, no solder, solutions, punchers, rivets, etc., and the splice cannot break the tape. A slot is cut between the flaps so that although the tape is firmly gripped, the slight bend is not enough to cause a breakage. The central portion *a* which is bent flat constitutes an automatic test of the quality of the metal in each splice."

Simultaneously with Mr. Weldin's letter, Mr. E. R. Tozer, of J. C. Uhner & Co., wrote the following concerning the Lucas quick tape repair band, shown in Fig. 1 (a):

"The Lucas quick tape repair bands are made from stout sheet brass so prepared that all it is necessary to do to repair a tape is to flatten the broken edges, remove any grease or rust with emery or sand paper, pieces of soft stone, or a knife, insert the ends equally into each end of the band; tap the band lightly to tighten it on the tape, then apply a little soldering material from a tube and heat with a match or two until the solder starts to run freely. After cooling, a strong, accurate job results, and it has taken only a moment.

These bands are made in sizes from $\frac{1}{8}$ inch up to $\frac{5}{8}$ inch. The whole outfit is contained in a little box which will go in a vest pocket. There are no liquids and all the tools needed are a stone and a match.

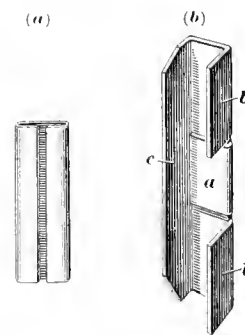

MINES AND MINERALS.
FIG. 1

Answers to Examination Questions

Questions Asked in Indiana Examinations at Terre Haute, 1911

(Continued from January)

QUES. 19.—(a) Describe the difference between the exhaust and blow-fan system of ventilation.

(b) Which is to be preferred under certain conditions for the ventilation of coal mines?

(c) Is the resistance any greater to be overcome in the use of the exhaust or the blow fan?

(d) In increasing the velocity of the air-current, or lengthening the distance the air has to travel through a mine is the resistance increased; if so, why?

ANS.—(a) The exhaust fan by creating a partial vacuum draws air from the mine. The blowing fan propels the air into the mine by creating a pressure, in fact is the reverse of the exhaust fan.

(b) As a theoretical proposition the exhaust fan is superior to the blowing fan. If the hoisting shaft is in a cold climate the main haulage way should be the return and this necessitates a blowing fan.

(c) The resistance is greater where a blowing fan is used at shaft mines.

(d) The resistance to the passage of air through airways increases as the square of the velocity. Lengthening the airway increases the rubbing surface which increases the friction, and hence resists the passage of air.

QUES. 20.—(a) If there are 27 cubic feet in a ton of coal, how many tons are there in an area of 5,000 square yards 6 feet thick?

(b) If 65 per cent. of this coal is recovered, without leaving any coal on the bottom or to support the roof, what is the area mined?

ANS.—(a) $9 \text{ sq. ft.} \times 5,000 \times 6 \div 27 = 10,000 \text{ tons.}$

(b) $5,000 \times .65 = 3,250 \text{ sq. yd.}$

EXAMINATION FOR FIRE BOSSES, TERRE HAUTE, 1911

QUES. 1. (a) State what experience you have had in gaseous mines. (b) The length of time you have been employed in coal mines. (c) What experience have you had with mine gases?

QUES. 2. What are the duties of a fire boss as required by law?

ANS.—This question is not definitely answered in the Indiana Mine Laws, 1907. He should enter the mine before the men go to work in time to examine the air-current, see that it is sufficient in volume, and is traveling in the proper directions. He should examine all working places and rooms to see if there has been an accumulation of gas; and if there has, he should fence off such place and permit no one to enter until the gas has been removed. He should frequently examine the edges and accessible parts of new roof falls, and old worked-out places for gas. If the territory he is obliged to cover is too large to perform the duties properly he should require an assistant. The object of the fire boss is to preserve lives and property; therefore, he must examine all working places—not merely the entrance to them. Other minor duties may be assigned to him, such as acting as assistant foreman after making his examination and report on the condition of the mine.

QUES. 3.—Should a fire boss be in absolute authority as to things pertaining to his work, or should he be under the supervision of the mine boss?

ANS.—The fire boss should be under the supervision of the mine boss; but he should have complete supervision over the mine and men until the mine boss relieves him of the responsibility by signing his report of inspection.

QUES. 4.—(a) What is a safety lamp? (b) Why is it safe?

ANS.—(a) The safety lamp is an arrangement whereby no outside atmosphere can reach the flame except through a wire gauze. (b) Safety lamps will not, unless their gauzes become overheated, allow the flame to pass through the gauze to the outside atmosphere. The standard lamp gauze has 28 parallel wires to the inch, crossing 28 other parallel wires, thus giving $28 \times 28 = 784$ openings

to the square inch. Under certain conditions, which every mine should know, safety lamps are not safe. Certain lamps are unsafe in an air-current of 7.5 feet per second, or when a person travels 4 feet per second against a current moving at 4 feet per second. Any lamp may become unsafe by overheating the gauze, or if an explosion occurs inside the lamp, or dirt accumulates on the gauze so as to glow and conduct the heat.

QUES. 5.—State what size blaze you would use in your safety lamp when examining for firedamp and why?

ANS.—I would use a low flame about $\frac{1}{4}$ inch high when testing for gas, because the non-luminous flame cap can be readily detected with this height, and the flame also will be elongated, thus furnishing at once a double method of detection. Percentages of gas can only be detected by practice with known quantities of gas, owing to the differences existing in people's eyesight.

QUES. 6.—(a) Name the different explosive gases found in coal mines. (b) How is each detected? (c) Give the composition of each. (d) Give their chemical symbols. (e) State where each is to be found.

ANS.—(a) There are but two explosive gases found in coal mines. One is a natural mixture of several gases and is variously termed marsh gas or firedamp by miners, and methane by chemists. If there is an explosion of marsh gas or powder or a gob fire, an explosive gas is formed called by miners "whitedamp," by chemists carbon monoxide. This, however, is seldom if ever found native. The other gas is hydrogen sulphide, which is sometimes found in small quantities. Although there is no record of its having caused a mine explosion, it is said to be violently explosive when mixed with seven times its volume of air and fired. (b) Marsh gas is detected with a safety lamp, and hydrogen sulphide, also called "stink damp," by its odor of rotten eggs. If carbon monoxide is to be included in the list, it is detected by birds or mice, who are killed more quickly by it than men. (c) Marsh gas is composed of one part carbon and four parts hydrogen. Hydrogen sulphide is composed of two parts hydrogen and one part sulphur. Carbon monoxide is composed of one part carbon and one part oxygen. (d) Marsh gas, CH_4 . Hydrogen sulphide, H_2S . Carbon monoxide, CO . (e) Marsh gas being lighter than air should show first at the roof, particularly where there has been a fall, or the air-current is sluggish. Carbon monoxide will be found in those parts of mines where there has been a firedamp explosion, a powder explosion, or a mine fire. Hydrogen sulphide is found where there is pyrite oxidizing in the roof, floor, or gob.

QUES. 7.—(a) Name the different non-explosive gases found in coal mines. (b) How is each detected? (c) Give the composition of each. (d) Give their chemical symbols. (e) State where each is to be found.

ANS.—(a) Nitrogen, oxygen, carbon dioxide. (b) Nitrogen and carbon dioxide will not support combustion, while oxygen will cause lights to burn more briskly. (c) and (d) Nitrogen, N ; oxygen, O ; carbon dioxide, one part carbon two parts oxygen, CO_2 . (e) Usually throughout the entire mine. Carbon dioxide, however, being heavier than air, will accumulate in dips if the air-current is not sufficiently brisk to sweep it out or cause it to diffuse.

QUES. 8.—(a) What is the meaning of specific gravity? (b) Give the specific gravity of gases found in coal mines.

ANS.—(a) (1) The specific gravity of a gas is the ratio between the weights of like volumes of gas and air having the same temperature and same pressure. (2) The specific gravity of a solid is the ratio of its weight to the weight of an equal bulk of pure water at a temperature of 62° F. (b) Air, 1; carbon dioxide, 1.529; carbon monoxide, .967; marsh gas, .550; nitrogen, .9713; oxygen, 1.1056; hydrogen sulphide, 1.1912.

QUES. 9.—(a) What is meant by the "Relative Weight" of the different gases? (b) Give the relative weights of the different gases found in coal mines.

ANS.—(a) Probably the weight of a certain volume of one gas compared with another under the same conditions of temperature and pressure. (b) Weight per cubic foot of air at 60° F. and 29 inches of mercury is .07405. If the mine gases are under similar

temperature and barometric pressure, then a cubic foot of the following gases would weigh:

Carbon dioxide	1.529	$\times .07405 = .11322$ lb.
Carbon monoxide	.967	$\times .07405 = .07260$ lb.
Marsh gas	.550	$\times .07405 = .04072$ lb.
Nitrogen	.9713	$\times .07405 = .07192$ lb.
Oxygen	1.1056	$\times .07405 = .08187$ lb.
Hydrogen sulphide	1.1912	$\times .07405 = .08821$ lb.

QUES. 10.—How many cubic feet of air is traveling an air-course which is $8\frac{1}{2}$ feet wide at the bottom and $7\frac{1}{2}$ feet wide at the top, and $5\frac{1}{2}$ feet high, with the anemometer showing a reading of 85 revolutions per minute?

ANS.—If one revolution of the anemometer corresponds to 1 foot of air passing, then

$$\frac{7.5 + 8.5}{2} \times 5.5 \times 85 = 3,740 \text{ cu. ft. air per min.}$$

QUES. 11.—(a) What effect does coal dust have on an explosion of firedamp? (b) What effect does whitedamp have? (c) What effect does blackdamp have?

ANS.—(a) Increases the explosion materially by producing a large volume of explosive gas. The kind of coal dust has a bearing on the force of the explosion. (b) Whitedamp or carbon monoxide will increase the intensity of an explosion, is exceedingly poisonous, and a few breaths of air containing 2 per cent. of the gas will render a man unconscious. (c) Blackdamp will tend to decrease an explosion.

QUES. 12.—What are the principal causes of mine fires, and what dangers and difficulties are to be met with in extinguishing them?

ANS.—Assuming that the question refers to spontaneous combustion, then oxidation is the cause of most coal mine fires. This occurs most rapidly in gob piles where there is little ventilation. When coal through oxidation reaches a temperature of 150° F., heat will increase rapidly. When 485° F. is reached it will ignite if exposed to oxygen of air. The dangers connected with mine fires under ordinary circumstances are: Asphyxiation in trying to put out the fire; back firing when fighting the fire; danger of fire spreading; or of generating coal gas and CO in volumes that might cause a general mine explosion. Among the difficulties incident to fighting mine fires are heat, smoke, getting to the fire so as to work and extinguish it satisfactorily.

QUES. 14.—(a) What is afterdamp? (b) What are its chemical properties?

ANS.—(a) A mixture of carbon dioxide, carbon monoxide, nitrogen, oxygen, hydrogen, carbon smoke and dust, or the products of combustion arising from an explosion of gas, dust, or gas and dust. (b) If it was derived from an explosion of gas the resultant gases would be carbon dioxide, carbon monoxide, hydrogen, nitrogen, and oxygen. If from dust, the same gases would be in evidence with more carbon monoxide. The chemical properties of afterdamp are usually of such a nature that they produce death.

QUES. 15.—(a) What is the composition of black powder? (b) What is the composition of dynamite? (c) What gases are generated by each when exploded?

ANS.—(a) Charcoal, sulphur, and saltpeter. (b) Nitro-glycerine with infusorial earth as dope or modifier. Wood pulp and other dopes are used at times. (c) Carbon dioxide, carbon monoxide, oxygen, hydrogen, and nitrogen. In the case of gun-powder, hydrogen sulphide, sulphur monoxide, and sulphur dioxide are additional. In case of dynamite, nitric and nitrous oxides are additional gases.

QUES. 16.—(a) What is the composition of fuse? (b) What gases does it generate in burning?

ANS.—(a) A jute thread saturated with gunpowder, first covered with a layer of yarn, then wound with a layer of tape, which is coated with pitch and surfaced with fuller's earth to prevent sticking. If two tapes are used for winding, fuse is known as double tape. Cotton and hemp fuse unwound with tape is sometimes made, but coated tape is more reliable as a rule. (b) The gases resulting from combustion are CO, CO₂, H₂, N₂, O₂, surely, and possibly some methane, in this case with smoke.

QUES. 17.—(a) What dangers arise from drawing pillars in a mine generating marsh gas? (b) What dangers would arise from drawing pillars from a mine generating a large amount of marsh gas which is being worked immediately under another mine separated by 125 feet of strata?

ANS.—(a) There is apt to be a liberation of gas from the roof rocks in such quantities as to form explosive mixtures by diffusion, or which, by catching fire, cause a mine fire difficult to extinguish. (b) To the dangers mentioned in (a) would be added the danger of filling the mine above with an explosive mixture from the gas that would find its way upwards through cracks in the roof rocks.

QUES. 18.—If, in the case of the mine mentioned in the above question, it should become necessary to draw pillars in the lower mine for the purpose of relieving a squeeze, what precaution would you take to insure the safety of the men in the upper mine? And if the pillars that were withdrawn in the lower mine were in advance of the workings of the upper mine what dangers would arise in driving toward the caved district, and what precaution would you take in so doing?

ANS.—This question implies that the squeeze will affect the mine above by gas and by a sinking of the floor. Under these circumstances the men should be withdrawn from the affected area until settling has ceased. It is possible that the floor, coal, and roof of the upper seam will be so broken that it cannot be worked to advantage if the pillars are withdrawn ahead of the upper coal workings. Danger would arise not only in supporting weak roof, sides, and floor, but from the gas that finds its way into the excavation. There should be a dam made and the gas which accumulates in the upper heading drawn off gradually so that the air-current will render it harmless. If it would take a long time to clear the affected area by this means, the matter could be hastened by attaching the discharge pipe to an air compressor, thus draining it off and discharging the gas outside the mine.

QUES. 19.—(a) Show by sketch how you would remove accumulated gas from the face of a working place which is considerable distance ahead of the air. (b) What precaution would you take to insure the safety of the men on the return air-current?

ANS.—(a) Place curtain at *a*, Fig. 1. Hang brattice cloth to posts, as shown at *b*. Arrows show direction of air. This work is frequently performed by a hand fan placed at *c*, an air pipe being used to carry the air in to the face. No curtain is then needed at *a*. (b) If there was more gas than the current could dilute, or if the gas was forced out in a mass before the air-current, the only safe thing to do would be to call the men out of a few rooms ahead of the gas, and keep open lights off the return until the gas has cleared.

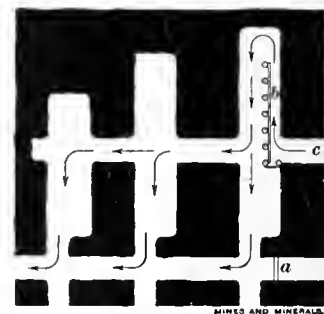

FIG. 1

QUES. 20.—(a) What is the meaning of an initial explosion? (b) If you were fire bossing in a mine where the old works had caved and filled up with gas, what precaution would you take to prevent an explosion? (c) What causes might lead to an explosion in this case?

ANS.—(a) When one explosion follows from another, the first explosion would be the initial explosion. (b) If possible, completely shut them off and draw off the gas gradually. This question is so broad it could be answered in other ways, depending upon the applicant's imagination; for instance, a bore hole might be put down from the surface and the gas allowed to escape in that way, but even then the old workings must be kept free from trespassers. (c) A fall suddenly driving gas into the airways; trespassers; increased diffusion due to fall in barometer. However, if the old workings are shut off and drained systematically, the above probable causes could not materialize.

ORE MINING AND METALLURGY

Bauxite Mining in Tennessee

Minerals Yielding Aluminum—Description of the Ores, Method of Occurrence and Mines in Operation

By George H. Ashley*

In the olden time it was the dream of men to find the philosophers' stone, which would change the baser metals to gold, but today men would be well satisfied to find some cheap and easy method of separating from ordinary clay the metal aluminum which it contains. Common clay, when pure, contains about 20 per cent. of the metal. A few years ago aluminum was a chemical curiosity, practically unknown to the average person; today it is extensively used in the arts and manufactures. It has many of the qualities of iron, and many desirable qualities that iron is lacking; but while aluminum is the most abundant metal in the earth, the separation by any present known



FIG. 1. BAUXITE MINE ON EAST SIDE OF MISSIONARY RIDGE

process is costly. Our present familiarity with the element is due in part to the fact that there are other substances besides clay that contain aluminum, and some of these yield the metal more readily than clay. Unfortunately all of these minerals from which the metal can be more readily obtained are comparatively rare. The best known are corundum, emery, cryolite, a mineral obtained principally in Greenland, and bauxite, pronounced bo'zit, though commonly called "boz'ite," named from the town of Baux ("Bo"), in France, near where it was first found. Corundum is a mineral too valuable as an abrasive to use as an ore of aluminum. Cryolite has been the common ore for some years, being brought down from Greenland as ballast by the whaling vessels; but of late bauxite has come to be the chief source of the metal. Chemically, bauxite, a compound of aluminum and oxygen, commonly contains from 50 to 70 per cent. of alumina, Al_2O_3 , and from 25 to 30 per cent. of water, with small amounts of silicon, iron, and titanium oxides.

Aluminum was first obtained in 1827 by the chemist, Wohler, as a fine gray powder, and afterwards as globules of metal; but the process was so difficult that even with improvements in

method, in 1856 the metal still sold for \$90 a pound. In that year the French chemist, Deville, invented a process that reduced the cost from \$90 to \$27, but even with this process the price continued high for another 30 years, or until the method of extraction by electrolysis was invented by an American, Castner. Under that process the price dropped in 1889 to \$2 a pound. Later improvements have continued to still further reduce the price to 20 cents per pound.

Bauxite was discovered in America in 1887, a few miles north of Rome, Georgia, in Floyd County. Ore shipments were made from that point in 1889. In 1891 shipments began from Alabama,

and about that time large deposits were found in Arkansas, which has since continued to be the principal source of the ore in this country.

Bauxite has been mined in Tennessee for about 5 years, principally by the National Bauxite Co., of Philadelphia. Only one mine, the Perry mine, is at present working. This mine is situated on the east side of Missionary Ridge, east of Chattanooga, half a mile south of the Southern Railroad tunnel that pierces the ridge in the suburb of

Sherman Heights. It can be reached readily by taking the Sherman Heights or East Chattanooga car to Glass Street. The mine consists of a rounded pit approximately 200 or 300 feet in diameter, 100 feet deep. A still larger area has been stripped, the stripping running from about 10 feet on the east side to a maximum of about 40 feet on the west side. The bauxite was first found in a well on the east side of the pit. Below the stripping, which contains a small proportion of scattered bauxite, the main deposit forms practically a solid mass, so far as developed, but the bottom of the deposit has not yet been reached. The mass is apparently lenticular, having increased in cross-section for

some distance in going down, but at present the cross-section is diminishing. While the deposit, as a whole, is a solid mass, in places there are "horses" of clay. One such "horse" on the east side, has extended downward the full depth of the pit, and a smaller clay mass projects cornerwise into the deposit on the west side.

West of the main pit is a smaller pit not being worked, as it is being used as a reservoir for water for the boilers of the mill. This pit has been excavated to 40 or 50 feet below the surface.

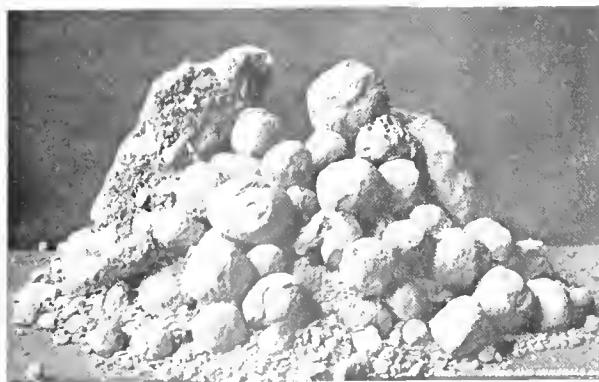

FIG. 2. PEBBLES OF SOFT BAUXITE ORE

*Resources of Tennessee.

The ore is mainly of a gray to creamy earthy substance sometimes stained red, in which are irregular masses of harder ore, which vary in color from an ashen gray to a dull red. These commonly consist of small rounded pellets, from gray to red in color, and from the size of fish roe to a diameter of from 1 to 2 inches, in a cement of similar material. In places where the pellets are the



FIG. 3. BAUXITE MINE, NATIONAL BAUXITE CO.

size of pebbles and the cement is soft, they are readily separated and accumulated in piles, as shown in Fig. 2. More commonly the cement is harder than the pellets, which often consist of a thin crust filled with a powdery substance, so that the mass as a whole resembles a rock sponge of a creamy or pink color. The pink or red color is due to the presence of iron, and in some cases the pellets are almost pure iron ore, and deep red, while the cement may contain very little iron and be light gray in color. When the pellets in this type of ore are one-eighth of an inch or less in diameter it is known as "oolitic" ore; when one-half or three-quarters of an inch it is known as "pisolitic" ore. Sometimes the pellets are fairly uniform in size, and are uniformly distributed; in other cases they are abundant in parts of the mass and scattered or lacking in other parts. When the mass contains very few "oolitic" concretions, locally called "block ore," it is rich in alumina, and low in both iron and sand. In parts of the mine these harder blocks are rather widely scattered, and in other places they form almost the entire mass.

Except the harder lumps of roughly rounded shape, the ore under ground is fairly soft. In the Perry mine, shown in Figs. 1 and 3, the ore is pick mined, and placed in cars on tracks that radiate from a central turntable from which, by slope, they are raised to the surface, and then go to the dryer, placed between the two pits. The bauxite as mined, especially the soft ore, contains a large percentage of water, and to save freight charges this is dried before shipping. The hard ore contains less moisture, and is separated in the pit and not dried. The drying kilns consist of large, slightly inclined, rotary cylinders, into the upper end of which the ores are continuously fed, while the heat is supplied by a firebox at the lower end, using coke. In case the pebble ore contains a large amount of clay, this is separated by a log washer. After prepara-

tion, the ore is carted one mile to a siding on the Southern Railroad. The two carloads a day being mined, go mainly to Philadelphia for the manufacture of alum.

Although this is the only mine working in Tennessee, bauxite has been found in a number of places nearby to the south and east.

Apparently not much ore is in sight at the prospect pits, but when it is remembered that the pits being worked showed no ore at the surface and increased in cross-section with depth, it seems as if there should be more ore than now appears at the surface. Again, the surface of the slope of the ridge where the bauxite occurs is weathered to a considerable depth and composed mainly of clay and chert fragments working their way down hill, so that it is likely that pockets of ore exist, of which no indication is seen at the surface.

At first sight it seems a hopeless task to hunt for a mineral that probably exists only in scattered pockets, an acre or less in size, lying hidden beneath the surface anywhere in an area of many thousand square miles. It is here that the geologists must step in and, if possible, determine the exact conditions that have led to the occurrence of the bauxite in the places now known, and then to find similar conditions so as to confine prospecting to those limited areas. In this study much can be gained by an examination of the developed deposits of Georgia and Alabama, as the Tennessee deposits appear to be in an extension of the same field.

First, it may be noted that the deposits so far known in Tennessee occur in a great formation of limestones, dolomites, and cherts, known as the Knox dolomite. The same condition is found to exist in Georgia and Alabama. But the Knox dolomite comprises a very uniform series of rocks from 3,000 to 4,500 feet thick, that are folded in various ways so as to underlie several thousand square miles in the Great Valley of East Tennessee. If it be true that the ore is confined to that series of rocks, prospecting need not be undertaken in the thousands of square miles underlain by other rock formations. But the area left is still too large to offer an attractive field, for it would still be too much like "hunting for a

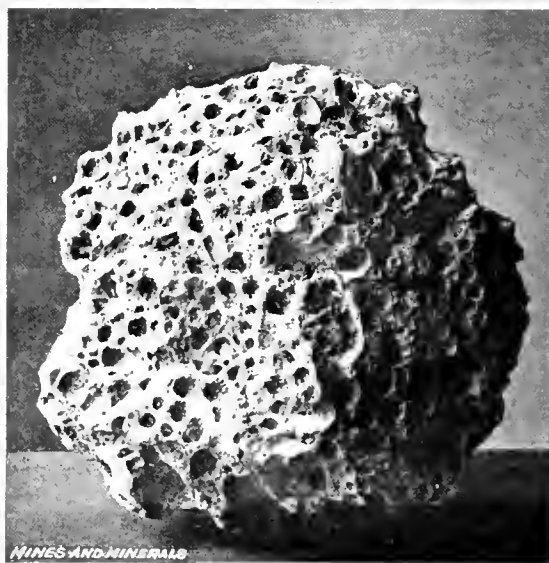

FIG. 4. BOULDER OF HARD BAUXITE ORE

needle in a hay stack." The exact conditions that give rise to the pockets of bauxite are little known. The association of the bauxite with certain other minerals, such as limonite and kaolin, may be noted, and the finding of those minerals on the surface may prove the key to the occurrence of the bauxite. Specimens of limonite found in the pit west of Hornville, suggest that the bauxite was an alteration or replacement product from the limonite, the iron of the limonite having been removed and replaced with alumina.

But one or two other features appear. It has been observed

that the bauxite pockets along the east side of Missionary Ridge are almost in a straight line parallel with the crest of the ridge, or in the "strike" of the rocks. Next it has been learned that the several occurrences have similar surface material at the points where found. It is observed that, starting from the crest of the ridge, there is a long fairly uniform slope from half to two-thirds of the distance down, then occurs a marked bench or flat, which has been cut through by the heads of the little gullies, leaving a series of flat projecting points. From this bench the ground again slopes down to the valleys on the east. The bauxite appears to occur only at the west side of this flat bench or where the bench meets the slope from the top of the ridge. The presence of the bench is evidence of a difference in the rocks underlying this slope, and the bauxite is evidently associated in some way with that difference. In the limited area examined on the east side of Missionary Ridge, the rocks have weathered to such a depth that only clay and chert could be seen. So that, without more extended investigations, it could not be determined just what kind of rock was responsible for the bench. One or two things are suggested. Either that there is a thin bed of rock in the Knox dolomite whose composition is readily susceptible to the secondary changes that result in the bauxite, or else there has been a break in the rocks and a displacement so as to bring rocks of a different composition in outcrop under the bench from that in the slope immediately to the west, and the deposits of bauxite have resulted from the presence of the break allowing movement of surface waters. In Georgia there seems to be a close connection between the deposits of bauxite and certain lines of faulting, in which the rocks have been broken across and pushed over each other. Such a fault does exist in Missionary Ridge, but in previous geologic work by the United States Geological Survey it has been mapped as occurring on the west side of the ridge rather than on the east side. Along the line of that fault the rocks on the east side have been pushed up so that the cherty limestones and dolomites of the Knox formation have been pushed over the rocks that naturally belong much higher, and which in general contain the red iron ores of East Tennessee. The ridge itself is the result of the presence on the east side of the cherts left from the decomposition of the dolomite, while on the west are the softer shales and limestones of the Rockwood formation, the iron ore-bearing formation of this district, and Chickamauga formation. Whether, in addition to the main fault, there is a nearly parallel smaller fault, which has been responsible for the presence of the bauxite, has not been demonstrated. Should such a fault be found, and should it appear probable that the fault has been primarily responsible for the occurrence of the bauxite, it will then be necessary to examine the whole area of outcrop of the Knox dolomite for the purpose of locating other similar faults. When such faults

have been located, it will then be in order to examine them critically both on the surface and with the drill in the hope of locating other deposits of bauxite.

來 來

A Remarkable Home-Made Mining Plant

By Frank C. Perkins

The waterwheel shown in the accompanying illustration is 29 feet in diameter and forms a part of a home-made mining and milling plant at Idaho Springs, Colo. This mining installation was started and completed with day's pay by C. M. Taylor, a miner of wonderful energy and ability who insisted on working the mine himself with his own resources, harnessing the waterpower of a neighboring creek to help him in his labors.

This mine consists of two large veins which cross like an X by the side of the creek, the mine drift being sunk at the junction

He states that the ore bodies are 10 and 12 feet wide and contain gold, silver, lead, and copper.

The 29-foot waterwheel was erected at the shaft, as shown in the illustration, to furnish the power for hoisting the ore and also for running a 10-stamp mill which the miner installed. The gate is moved at the top by a lever, allowing the water to overflow or to operate the wheel as desired. A drum on the end of the waterwheel shaft hoists the bucket out of the mine shaft and dumps the ore into the mill hopper. The ore is fed by an automatic feeder to the stamps and then passes over an amalgamating plate and through a quick-silver trap on to a concentrating table.

The hoist is controlled by a lever at the frame, and the bucket is dumped by hook and chain while the operator holds the lever, without leaving his post. If moist, the ore is dumped by another hook and chain into a bin or chute to be trammed away. The small boiler shown at the right in the illustration furnishes steam to run a compressor for a machine drill in the mine. The mill runs day and night, only one man being required to handle the mill and the mining equipment. The machinery is not housed in, and on account of the unique construction and the low expense of operation, this energetic miner is enabled to handle the same with but very little hand labor and without outside capital. He holds that with these large ore bodies this will grow into a great mine in the near future. Without doubt this installation is one of the most unique mining, milling, amalgamating, and concentrating plants in Colorado.

來 來

Bolivia's tin production increased materially during the first 6 months of 1911. The exports amounted to 19,052 metric tons of 60-per-cent. ore and 12,431 metric tons of pure tin.

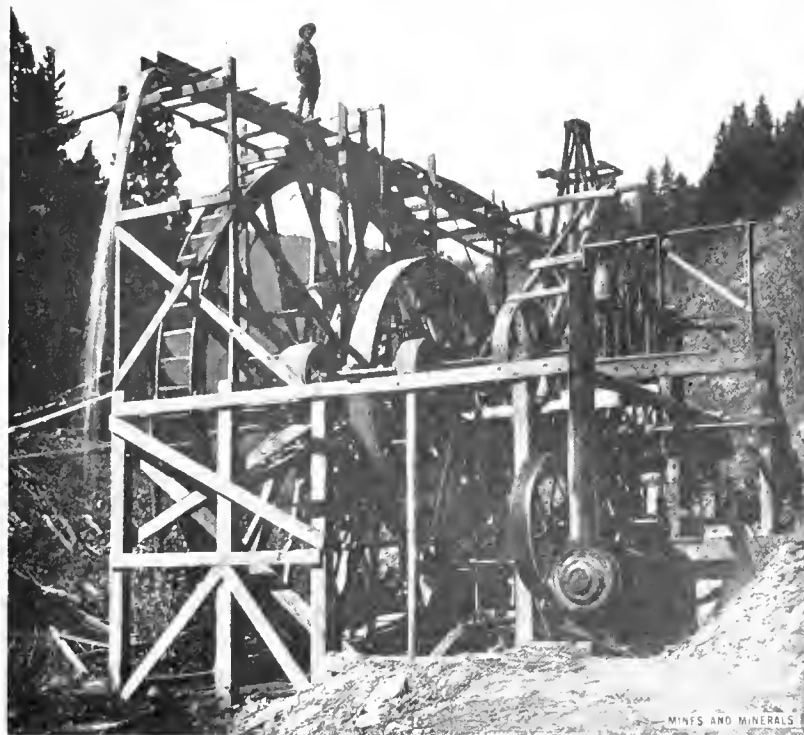

HOME-MADE REDUCTION PLANT

Placer Mining in Quebec, Canada

Extensive Operations Following a Course of Systematic Prospecting of the Ground

The following information is obtained from several sources, chiefly, however, from the Report on Mining Operations in the Province of Quebec, 1910, issued by Department of Mines, Quebec.

In Southeastern Quebec, in Beauce and Dorchester districts, tributary to the River Chaudiere, considerable washing was done for gold in the 60's and 70's, particularly near River Gilbert Gold Mines. While there is some coarse gold in the alluvials of this valley, the greater part of it is fine and does not average enough to make day's wages with the pan, except when a rich spot is found. After carefully drilling and washing the dirt from the holes to ascertain the quantity of gold and so obtain its average worth, The Dominion Gold Fields Co., Ltd., acquired the right to wash or mine for gold on 70,000 acres of land on the Rigaud-Vaudreuil Seignior, in Beauce district.

Mr. Fritz Cirkel, of Montreal, consulting engineer for the company, used up the entire season of 1910 in testing the ground, in the selection of the place to commence operations, and in the preliminary construction necessary for hydraulic placer mining, so that in the spring or summer of 1911 mining operations could be pushed vigorously.

The company for good and sufficient reasons had its name changed in 1911 to "La Compagnie des Champ-d'Or Rigaud-Vaudreuil," and began mining on Des Meules Creek, 1 mile southwest of Beauceville. To obtain water for the hydraulic nozzles at a sufficient head to disintegrate the gravel deposit, Lac Fortin, a body of water $\frac{2}{3}$ of a mile wide and $1\frac{1}{2}$ miles long, was decided on, although it was about $7\frac{1}{2}$ miles distant. From this lake 32,000 feet of ditch, 4,500 feet of flume, and 2,400 feet of pipe line were constructed. The ditch, which in section is $3\frac{1}{2}$ feet wide at the bottom, 5 feet wide at the top, and 3 feet high, and the flume, which is 4 ft. x 4 ft., terminate in a penstock to which the pipe line is connected. The difference in elevation between the hydraulic nozzles and the penstock is 260 feet, which will furnish a pressure of about 110 lb. per square inch at the nozzle, which is considered sufficient in this case. At a distance of 1,400 feet from the penstock the 18-inch diameter steel riveted pipe is connected with two 10-inch diameter branch pipes, each 500 feet long, steel riveted, and terminating in hydraulic nozzles. Each branch pipe is fur-

nished with a set of three nozzles having orifices 2, 3, and 4 inches in diameter. One of the nozzles is to disintegrate the gravel and the others to furnish water to drive the material through the bed-rock sluice to the elevator pit. The bottom of the sluice is on highly inclined rock strata, which offer natural riffles for holding the gold; therefore, the use of block or stone riffles is not anticipated to be necessary. At the date this is written three satisfactory clean-ups have been made without the use of block riffles. At the end of the sluice there is an elevator pit which is supplied with an electric-driven bucket elevator equipped with a stacker to take care of the debris resulting from the washing operations.

The tailing material is raised 40 feet by elevator buckets having a capacity of $1\frac{1}{2}$ cubic feet and weighing 550 pounds, and is discharged into a steel-plate sluice where the material is carried to the end of the stacker by a stream of water supplied by an electric-driven centrifugal pump having a capacity of 6,000 gallons a minute.

Power is supplied from a steam power house built near the station at Beauceville. The equipment consists of two 100-horsepower boilers, one 220-horsepower engine, with a flywheel 15 feet in diameter. The engine drives a 150-kilowatt dynamo, superheaters for boiler water, injecting pumps, fan for force draft, etc.

The power is transmitted to the field of operations by a copper transmission line 8,000 feet long at a voltage of 2,200, which is reduced by a transformer to 440 volts.

The plant is in charge of a staff of California miners of experience, and nothing is being neglected for the success of this enterprise. This is the first installation of its kind in the alluvial gold fields of the eastern townships, and the results are awaited with great interest.

采 采

A United States Consular Report states that in the Nogales district, Mexico, mining operations are carried on in every conceivable fashion, from the methods of the native Indian placer

miner, who ekes out a bare living with a crude dry washer, to those of powerful companies with millions of dollars invested and employing thousands of men. As a whole, however, the mining industry in this district is still in the development stage. Some companies have spent large sums in development work. In a few instances two or three million dollars have been invested in mines which have not yet begun to ship ore. In fact, at this time only a few companies are marketing their product in any considerable quantities.



HYDRAULIC "GIANT" NEAR BEAUCEVILLE

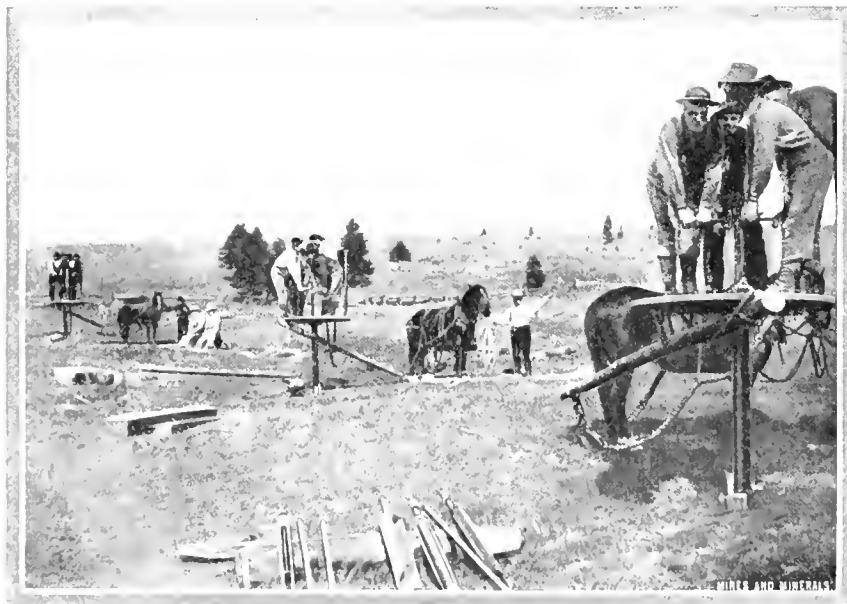

TESTING ALLUVIAL DEPOSITS WITH EMPIRE DRILLS

Refining of Base Bullion

The Processes Used in Softening, Desilvering, and Refining Base Bullion at Broken Hill, Australia

By W. Poole, B. E.

This article is abstracted from a paper entitled "Treatment of Broken Hill Ores" read by W. Poole, B. E., Director of the Charters Towers School of Mines, before the Sydney University Engineering Society.

The only lead refinery in Australasia at present at work is that of the Broken Hill Proprietary Co., at Port Pirie, South Australia. The following will, therefore, be mainly a description of the process as carried out at Port Pirie. These works are very complete. The products are soft lead, antimonial lead, refined silver, and refined gold.

The refinery contains five units, each consisting of copper softening furnace, antimony softening furnace, two desilvering kettles, refining furnace, and molding kettle; together with four liquation furnaces (not in use), two double retort furnaces, eight cupel furnaces, one reverberatory furnace for treating retort drosses, a doré parting plant, a small reverberatory furnace and cupola for treating antimonial by-products, and a power plant for supplying motive power, compressed air, circulating water, etc.

Copper Softening.—The base bullion from the smelters is fed into the reverberatory softening furnace shown in Fig. 1 through the two doors at the side, and the one at the end, an implement called a "peel" being used for this purpose. A charge contains 35 to 40 tons, a usual one being 38 tons, giving about 31 tons of soft lead at the molding kettle, the other seven tons being removed from the charge during the various processes of softening, desilvering, and refining. The charging takes 2 to 3 hours. The furnace is fired sufficiently to cause the charge to be slowly settling down while charging. The charge is allowed to stand at a low heat and then cooled back, and the solidified dross is skimmed off by a slightly dished and perforated iron plate on the end of a long iron rod. The dross contains most of the copper as a copper-lead alloy of less fusibility than the rest of the bullion, together with any sulphides which may have been dissolved in the bullion, as well as any mechanically held foreign matter. The copper dross obtained is 3,000 to 6,000 pounds per charge. The operation takes from 6 to 12 hours, 8 hours being the average time. The operation is lengthened or shortened to suit arrangements with the antimony softener. The dross varies in composition, containing lead, 70 to 80 per cent.; copper, 6 to 12 per cent.; silver, 45 to 65 ounces per ton.

The following may be taken as typical of the composition: Lead, 70 per cent.; copper, 8 per cent.; silver, 58 ounces; gold, .3 pennyweight; iron, .8 per cent.; zinc, 1 per cent.; sulphur, 5 per cent.; arsenic, .5 per cent.; antimony, .7 per cent.; insoluble 2 per cent.

The bullion from the copper contains* copper, .125 per cent.; arsenic, .094 per cent.; antimony, .18 per cent.; silver, 70 to 80 ounces per ton; gold, 1 pennyweight per ton.

The copper dross is sent to the smelters for treatment in a blast furnace, in which the various refinery by-products are retreated. The skimmed lead is tapped into the antimony softener, which is at a lower level, crossing to it by means of an iron launder.

There is a tendency for accretions to grow on the side walls of the furnace at about bath level. The accretions are chipped off from time to time, and the effects of the chipping constitute the greatest wear and tear on the furnace linings. The lead bath is kept just about level with the top of the water-jacket. The fuel used in the furnace is about 2 per cent of the bullion.

Antimony Softening.—A reverberatory furnace is used of the same type and size as that for copper dressing, but is more strongly stayed, to resist the greater strain thrown upon it by the stronger firing. The sides in front of the water-jacket burn back to the nose of the jacket in the space of a few days. The level of the lead is then kept down to the point of the jacket, and not over the top inclined side, as this latter requires very much extra firing on account of extra cooling action on the bath. These furnaces require repairing, principally relining around the bath level, about every 3 weeks. A good stream of water is required to be kept going through the jackets. If the side stays spring out, the bottom is apt to spring and lift up. The charge consists of the bullion from the copper softener, together with 50 to 80 bars of antimonial lead from the antimony dross furnace. The furnace is strongly fired for about 6 hours, during which the molten charge is stirred, so as to bring the antimony and other impurities to the surface to oxidize them. The furnace is cooled slightly, and as soon as the litharge and contained impurities have solidified they are skimmed off.

The furnace is again strongly fired, stirred, and allowed to cool slightly, and is skimmed again. This operation is repeated until the litharge is of a bright yellow color

First skimming, from 1,000 to 2,000 pounds (average 1,300 to 1,400 pounds), dross is obtained.

Second skimming, from 1,000 to 2,000 pounds (average 1,400 to 1,600 pounds) of dross is removed.

Third skimming, from 0 to 700 pounds of solidified impurities.

Generally, there are only two skimmings, in which case the second is a heavy one. The time taken for softening is from 12 to

16 hours, but is lengthened to suit convenience of desilvering kettle. The coal used in firing is equal to about 3 per cent. of the bullion.

The skimmings vary in composition about as follows: Lead, 70 to 85 per cent.; antimony, 7 to 12 per cent.; silver, 1 to 5 ounces per ton; arsenic, .5 to 1.5 per cent.

The following may be taken as typical dross: Lead, 73.8 per cent.; antimony, 9 per cent.; silver, 3 ounces per ton; arsenic, 12 per cent.

The bullion still contains small quantities of impurities, which do not materially affect the desilvering process; for instance, copper, from .10 to 1.4 per cent.; arsenic, from nil to trace; antimony, from .05 to .1 per cent.

The bullion is tapped into desilvering kettles, which are on a lower level. The softness of the lead bullion in the antimony softener is determined as follows: A small ladleful of metal is taken from the furnace and quickly poured out on the clean iron floor plates. If there is more than a minute amount of antimony present, the lead runs out more or less in beads, and the surface is white. If the lead is soft enough to be sent to the zinc kettles the lead runs in a thin sheet, the surface of which is bluish iridescent in color. The softened bullion is tapped from the furnace into a launder, and flows into the desilvering kettles, also known as the zinc kettles.

Treatment of Antimony Skimmings—The skimmings from the antimony softener are treated in a small reverberatory furnace, 11 ft. x 6 ft. 6 in. internal dimensions. The crucible is encased

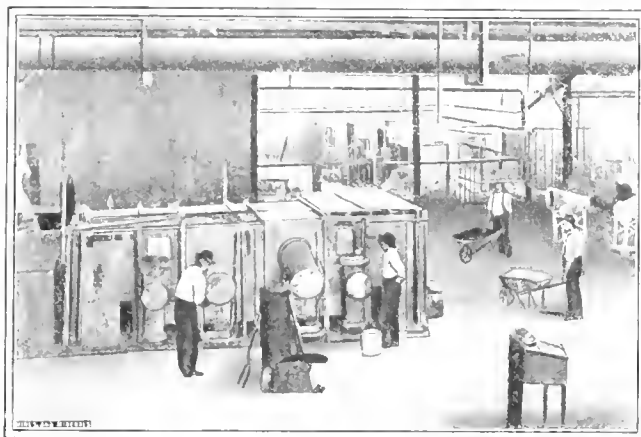

FIG. 1. REVERBERATORY FURNACE AT PORT PIRIE

* Baly, Trans. Aust. Inst. Mining Engineers, Vol. XII.

in an iron pan, but is not water-jacketed. The furnace is known as the antimony dross furnace.

The skimmings are charged into the furnace, mixed with fine coke and coal, producing bullion and slag. The slag contains a large percentage of lead and most of the antimony, the bullion containing a low percentage of antimony. If it is attempted to clean too much lead out of the slag an increasingly larger amount of antimony is also thrown out into the bullion. The bullion is returned to the antimony softener, and the slag is further treated in a small blast furnace. A charge for the reverberatory furnace is, antimony skimmings, 2,800 pounds; powdered coke, 110 pounds; powdered coal, 110 pounds.

Twelve charges per 24 hours are treated, and the slag is tapped once a day. It is run out and across three matte molds to catch any metal. The slag passes out into a compound on the floor, made of fine slag and strips of wrought iron. After cooling, the slag is broken up and stacked for treatment in the antimony blast furnace, which is only run periodically. The product from reverberatory furnace is bullion, from 100 to 150 bars per day; slag, from 8,000 to 13,000 pounds per day.

A typical analysis of antimony dross furnace slag and bullion is—Slag: lead, 52 per cent.; antimony, 27 per cent.; arsenic, 5.5 per cent.; silica, .7 per cent.; silver, 2 ounces per ton. Bullion contains: arsenic, trace; zinc, .005; copper, .12 per cent.; antimony, .66.

The slag from the antimony dross furnace is treated in a small water-jacket blast furnace, 32 in. X 48 in. There are four tuyeres to this furnace, each 3-inch diameter. The shaft is 10 feet 6 inches from tuyeres to flue. Composition of charge: antimony slag, 450 pounds; returned slag, 250 pounds; scrap iron, 10 pounds; coke, 90 pounds.

About 32 charges per 8-hour shift are treated, producing 70 to 75 bars of antimonial metal. The iron takes up most of the arsenic and some of the antimony to form a speiss. About 5 to 10 tons of basic slag is obtained from the smelter, and used over and over

There is very little silver in the antimonial metal or blast furnace slag, most of it being removed in the bullion resulting from the operation in the antimony dross furnace.

The antimonial lead bullion is run out into a drossing kettle, shown in Fig. 2. This kettle is semispherical, about 4 feet diameter. The top of the kettle is 2 feet above the floor. The kettle is set in brickwork, and the latter set in iron. Fire is placed under the kettle, so that the bullion may be maintained at a proper molding temperature, which is below red heat. A tubular ring of wrought iron, 1 inch thick by 3 feet diameter and 18 inches deep, floats in the bath of molten metal. When bullion is tapped from the furnace it runs into the kettle between the outside of the kettle and outside of the bailing ring, and the dross collects as a mush on the outside of the ring, and is removed from time to time. The molten metal on the inside of the ring is carefully skimmed, and the metal then ladled out into molds, and the surface of the metal in the molds carefully skimmed before it sets. The dross and skimmings are returned to the furnace.

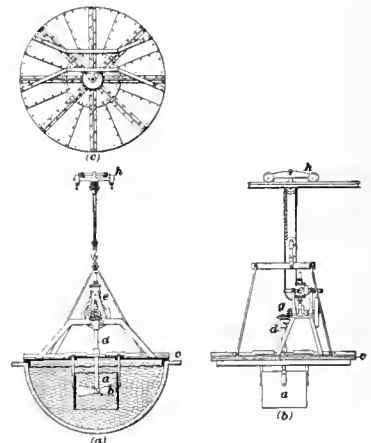

FIG. 3. HOWARD STIRRER

The Desilvering of Softened Lead Bullion.—The Parkes process is used for removing the silver and small amount of gold present in the bullion. Zinc forms alloys with silver, gold, lead, and copper, which have lower specific gravities and higher melting points than metallic lead. Zinc has a greater selective power for gold and copper than for silver. It is, therefore, possible to remove by successive small applications of zinc the whole of the gold, while leaving the greater part of the silver in the bullion. The amount of gold in the bullion is small; viz., about 1 pennyweight. If the gold-silver-lead-zinc alloy obtained by the first application of zinc is directly treated and reduced to doré bullion, the amount of gold contained in the latter is very small. The gold-zinc alloy is, therefore, returned to several fresh pans of bullion, in order to increase the gold contents of the gold-zinc crust, and ultimately to greatly reduce the amount of doré bullion to be parted.

The charge run out from the antimony softening furnace into the zinc pans is skimmed, and 1 to 2 hundredweights of dross removed and returned to the furnace. This dross contains on an average about 85 ounces of silver. The process is a complicated one, and is as follows:

Gold Zincing.—First first-zinc: To an untreated pan is added 250 pounds of spelter, melted down, stirred in, pan cooled back, and then skimmed. The skimmings are put one side. "First time through" = B.

Second first-zinc: Zinc according to the gold left in the pan is added, stirred in, pan cooled back, and skimmed, and skimming put one side = C.

Pan is now clean of gold.

Another pan of bullion is then treated as follows:

First first-zinc: Both of the above zinc skimmings B and C are put together into the pan, and stirred, the pan cooled back and skimmed, and the skimmings put on one side. Known as "First zinc second time through" = A.

Second first-zinc: Spelter or scrap zinc is now added, the amount varying according to the amount of gold left in the pan. The zinc is stirred in, pan cooled back, and skimmed. The skimmings are put on one side as a second first-zinc = C.

The pan is clean of gold.

A third pan of bullion is treated as follows:

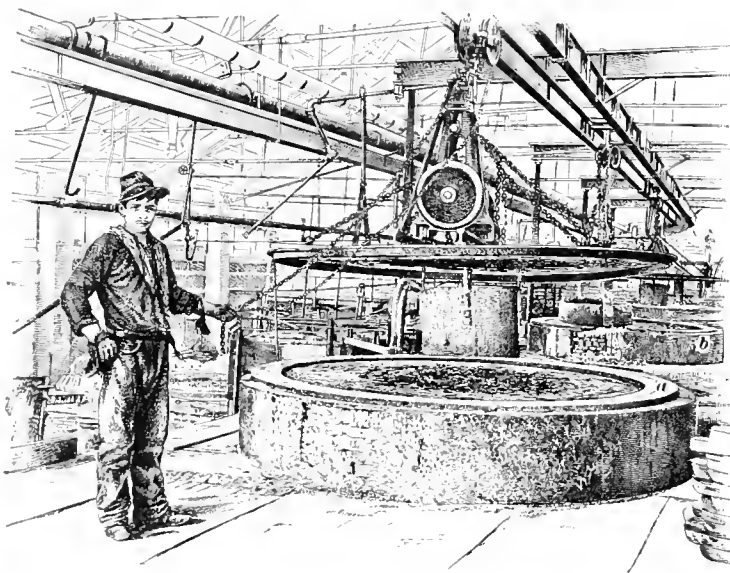

FIG. 2. DROSSING KETTLE

until it is foul, then it is sent to the dump. The products from the antimony blast furnace have the following analyses:

ANTIMONIAL LEAD	
Lead.....	76.0 per cent.
Arsenic.....	1.8 per cent.
Zinc.....	.1 per cent.
Copper.....	.2 per cent.
Antimony.....	21.5 per cent.
Silver.....	2.0 ounces

ANTIMONY BLAST FURNACE SLAG	
Lead and antimony.....	6.2 per cent.
SiO ₂	30.5 per cent.
FeO.....	26.9 per cent.
MnO.....	3.8 per cent.
CaO.....	9.5 per cent.
Al ₂ O ₃	17.0 per cent.
Zn.....	5.0 per cent.
Ag.....	1.0 ounce

First first-zinc: The previous second first *C*, together with 150 pounds scrap zinc or 120 pounds ingot spelter, is added, stirred in, pan cooled back, and skimmed, and called "First-zinc first time through" = *B*.

Second first-zinc: Then sufficient zinc to clean from gold is added, stirred in, pan cooled back, and skimmed, and the skimmings put on one side = *C*.

A fourth pan of bullion is treated as follows:

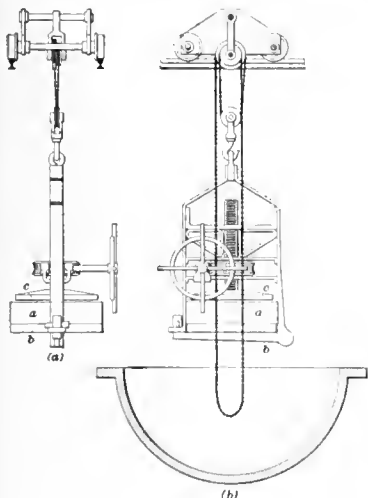

FIG. 4. HOWARD PRESS

First first-zinc: To this pan is added a first time through first skimming *B*, and also second first skimming *C*, stirred in, pan cooled back, and skimmed. This skimming is a "First-zinc second time through" = *A*.

Second first-zinc as before, product = *C*.

A fifth pan of bullion is treated as follows:

Two lots of low-grade alloy, known as "first-zinc second time through" *A*, are added and stirred in. After the pot has been cooled back it is skimmed, and the skimming pressed in a Howard press. The product is known as "pressed gold alloy."

Treatment of Gold-Zinc Alloys.—The gold-zinc alloy is allowed to accumulate for a "run." It is fed into retorts, and kept there for 4 hours. No zinc is recovered, as the retort furnaces are not fired enough. The dross is skimmed off from the retort charge, and the bullion dipped out into molds. This bullion contains about 225 ounces of silver and 7 ounces of gold per ton of bullion. It is stacked until there are about 1,600 bars, that is, sufficient for a charge in a zinc pan. It is then fed into a zinc pan, and melted down at a low temperature. When the charging is complete the temperature is raised, and the charge well stirred, without the addition of zinc. After the pan has been allowed to cool back it is skimmed, and the skimming pressed. The pressed skimming, low in gold, is treated in sweat cupels. A large amount of zinc is added to the charge in the zinc pan, and stirred in. After the pan has been cooled back it is skimmed, but not pressed. The gold-zinc alloy, now very high in gold, is sent to the retorts. The bullion from these is run down in cupels to doré bullion, as hereafter explained.

Silver Zincings.—Second zinc: The first lot of zinc added to remove the greater part of the silver is known as the "second zinc." Usually the zinc added to the charge is the zinc alloy skimmed from the third zinc. If there is insufficient or no "third zinc" skimmings available, it is in part or wholly replaced by scrap zinc or spelter. In the latter case about 700 pounds of zinc is added. After the "second zinc" has been added it is stirred in, the pan cooled back, the alloy skimmed, and pressed. The pressed silver alloy is sent to the retort furnaces for treatment, as hereafter described.

Third zinc: About 700 to 800 pounds of spelter or scrap zinc is added and stirred in. After the pan has been cooled back the alloy is skimmed off, and set aside, to be used as a "second zinc."

Fourth zinc: The third zinging usually leaves the pan clean—that is, .3 to .4 ounce of silver per ton of bullion. If not, a small amount of zinc is added. The amount of zinc used is determined by the amount of silver left in the charge, a table based on experience having been drawn up for that purpose. The alloy is skimmed off, and set aside without pressing, and is often fed into another pan as part of the third zinc.

The time of the whole of the desilvering (including gold) operations for each pan is about 32 hours for each charge. About 3.2 per cent. of coal is used in this operation.

Bullion from antimony softener: *Au*, 1 to .6 pennyweight; *Ag*, 72 to 82 ounces; *Cu*, .12 per cent.; *As*, nil; *Sb*, .089 per cent.

After "first first-zinc": *Au*, 19 grains; *Ag*, 70 to 80 ounces per ton.

After "second first-zinc": *Au*, trace to 5 grains; *Ag*, 68 to 75 ounces.

After "second zinc": *Au*, none; *Ag*, 20 to 30 ounces.

After "third zinc": *Au*, none; *Ag*, .3 to .5 ounce per ton; *Zn*, .56 per cent.; *Cu*, .00026 per cent.; *Sb*, .00325 per cent.

Howard stirrers, shown in Fig. 3, are used to stir the zinc into the charge of bullion, doing away with the very hot and laborious hand stirring. Howard presses, shown in Fig. 4, are used to press the excess lead out of the zinc alloy skimmings instead of liquating the zinc crust in a liquation furnace, effecting a great saving in time and also in cost.

After the pans are clean of silver, the bullion is siphoned off, and run into the refining furnaces.

Lead Refining.—The operation known as refining is undertaken to remove any residual impurities which may remain in the desilverized lead before it is run into the molds as soft lead. In this operation the lead is refined in a reverberatory furnace, then run into large pans, in which it is allowed to cool to a convenient molding temperature.

These reverberatories are similar in size and construction to those used in copper dressing and antimony softening, except that the depth of the bath is naturally less and the furnace is more strongly bound together than either of the preceding, on account of the long-continued strong firing. The residual of the zinc added in desilvering is removed, together with any antimony which may not have been removed during softening.

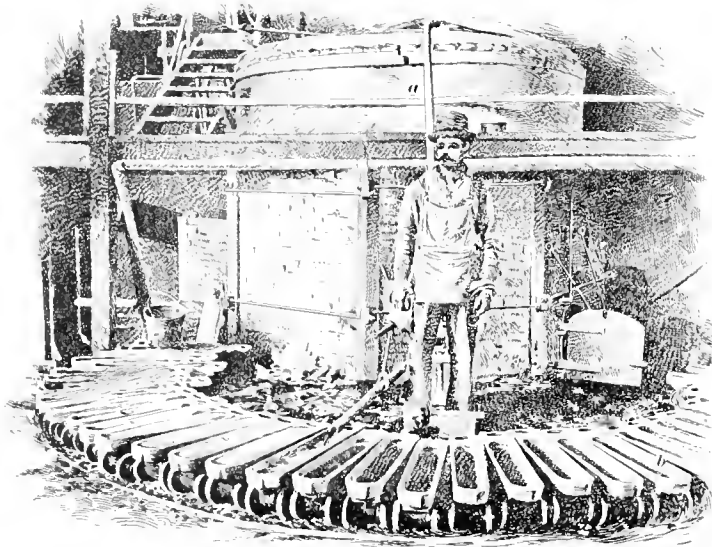

FIG. 5. LEAD MOLDS

The furnace is strongly fired, and the charge stirred to bring fresh metal to the surface. The heat is let down to stiffen the skimmings, which are then swept off into slag pots. The pots are stood aside to cool somewhat, and any lead which may have been drained out of the skimmings is tapped into bars through the hole in the bottom of the pot. These bars are returned to the furnace. The skimmings are known as "lead dross." Two skimmings are taken off. Prior to removing the second, the lead is tested for softness. The bath is stirred up, and a ladleful is removed and allowed to cool, skimmed with a piece of board, then poured into a taper mold, 8 in. x 2 in. x 1 in., and again skimmed. The presence of antimony is shown by a white spot or frosting on the surface of the bar. The presence of zinc prevents the surface of the bar

showing the characteristic fern-like crystals. The surface of the bar also does not show the typical bluish-white surface or the iridescent indigo-blue tint. The latter is a good test of freedom from impurities, although the absence of such tint is not a proof of impurity. The surface of the bar should be very easily scratched with a finger nail.

The lead dross is sent for treatment to the blast furnace. Time of operation, about 16 hours. Coal used is equal in weight to 4 per cent. of bullion.

Typical composition of lead dross: Lead, 85 per cent.; silver, .1 ounce per ton; zinc, 11 per cent.

After the lead has been cooled back it is tapped into the molding kettles. Accretions of zinc compound grow on the walls of the furnace, and require chipping off from time to time. As the lead dross skimmings contain an infinitesimal amount of silver (about .1 ounce), experiments have been made to arrive at a workable process by which to work them up to soft lead without sending them to the blast furnace, where the resulting lead again becomes mixed with silver-lead bullion, and must, therefore, again go through the whole desilvering and refining process. In one case they were treated in an iron kettle, but without success, as they stuck to the side and the kettle failed. On another occasion they were put into a refining reverberatory furnace, but without success. The bottom of the furnace failed, and the lead ran out through the bottom of the pan. They could be treated successfully in a small blast furnace set apart for their use.

Molding for Market.—The lead pans are of cast iron, similar to the desilverizing pans, of the same diameter, but not so deep. They hold about 35 tons of lead.

The lead is here again skimmed of the dross which forms on its surface, brought to the requisite temperature, which is below red heat, and then siphoned into molds, as shown in Fig. 5, which are arranged in a semicircle in the molding pit. The skinning of litharge which is removed from the pan is returned to the refining furnace. The molds are of two sizes. The larger give large, or "China," bars, about 11 to the ton, and are destined for the China market. The smaller give "Europe" bars, about 20 to the ton, and are intended for all markets except China.

The siphon is similar to that for emptying the desilverizing pots. The horizontal limb may be worked round in a semicircle. Each mold is separate, provided with a pair of wheels at one end, and with a stump foot and a handle at the other. Before the molding is commenced, and at intervals during the molding, the molds are whitewashed with lime. Two men undertake the molding operation, one in charge of the siphon outlet running the lead into the mold and then skimming it with a convenient iron tool; the second man stamps each bar with the number of the molding, wheeling each bar and stacking it at the side of the pit, and replacing the mold at its original place in the semicircle for further use. Time of operation, about 4 hours. The refined lead is one of the softest and purest on the English market. The following analyses may be taken as typical:

	Per Cent.	Per Cent.	Per Cent.
	1	2	3
Lead.....			99.99366
Silver.....	.001710	.001220	.00096
Copper.....	.000324	.000277	.00026
Zinc.....	.001710	.000926	.00187
Antimony.....	.003170	.002970	.00325

1 and 2 private notes. 3. Average for year.

Soft lead for the British and European market requires to be very low in silver (.2 to .3 ounce per ton). The recovery of silver to this cleanness does not pay for the silver recovered, but it is necessary to come down to this, as a large amount gives a slight yellow tint to white lead, in the manufacture of which much of the Broken Hill Proprietary Co.'s lead is used. Lead containing over the above amount and less than 1 ounce is molded into China bars.

Retort Furnaces.—The retort furnaces contain two compartments, back to back, with two retorts in each compartment. The

furnaces are fired with gas, which is generated in a small adjacent producer. The furnace is built over regenerative chambers, to heat the air used for combustion. Each compartment is fired separately, and has its own separate producer and regenerative chambers. The directions of the current of air and furnace gases are reversed every half hour by means of a butterfly valve. An ordinary clock is fitted to ring an electric bell, so that the time of reversal is not overlooked. Gas firing enables the temperature of the furnace to be more fully regulated. The interior of the furnace is kept clean, and the retorts kept free from adhering coke, clinker, ash, etc., and therefore last longer. Also, in cases of failure of retort, the bullion is not mixed with a lot of ashes, etc., and is easier removed.

The retorts, 3 feet 6 inches high by 2 feet, are made of a plum-bago mixture; they are fixed in an inclined position, and last about 50 to 60 charges. Tilting furnaces enable the charge to be more readily removed, but they do not last so long, nor are they so easily and economically fired. The retorts are bailed by hand. Two men look after the furnaces, and take it in turns to bail. The man doing the bailing stands on a movable platform, and dips the bullion out into molds placed on a long iron truck. The other man takes the truck of full molds away, tips the bullion out of the molds, stacks it for further treatment in cupel furnaces, and places another truck of empty molds in a handy position for his mate who is bailing. The latter man is protected in front from neck to knee by a thick apron made of jute bagging. The hand and arm near the retort are protected by a thick gauntlet and sleeve of the same material. A muffler is wrapped round the neck and lower part of the face, and a thick slouch felt hat drawn down as low as possible over the face. Thus protected, the furnacemen experience little difficulty or inconvenience in dipping the bullion out of the white-hot retorts.

About 12 hundredweight of dry alloy is fed in per charge. The retort is filled up to the neck with lumps of alloy. As this settles the rest is fed in until the retort contains the whole charge. The condenser is then wheeled up in position, the mouth luted to the sides with fireclay, and the heat of the furnace raised. The condenser is of sheet iron, lined with the same material as used for cupel buttons. The condenser is cylindrical in form, and inclines downwards from the furnace. The far end is flat, and has a small tap hole, closed by cement, while a small vent is left on top of the cylinder. The length of operation is about 10½ to 12 hours. The products are: *Au-Ag-Pb* bullion, or *Ag-Pb* bullion, distilled and condensed zinc dross, a small amount of blue powder and fume. The zinc is distilled off from the alloy, and is condensed in the cylindrical condenser, from which it is tapped from time to time. The zinc is returned for further use in the zinc pans. The fume, small in amount, is zinc with a little lead. It escapes from the top of the condenser, and is lost. The blue powder is sent to the blast furnace on refinery drosses. When the distillation is complete all the remaining zinc is tapped from the condenser into molds, and the condenser removed, the dross skimmed off, and the bullion tipped out into molds. The further treatment of the bullion and dross will be described later. Old retorts are broken up, and sent to the blast furnaces on refinery products.

來 來

Report of Broken Hill South Silver Mining Co.

The average assay of the sulphide ore being mined at the Broken Hill South, New South Wales, Australia, was 14.6 per cent. lead, 6.5 per cent. silver, and 13.6 per cent. zinc. The value of this ore has increased between the 970- and the 1,070-foot levels, but is not nearly so rich as at the 425-foot level. The cost of mining ore was 10 shillings 8.6 pence per ton; the cost of filling stopes 1 shilling 7.7 pence per ton; development work cost 1 shilling 3 pence per ton; milling cost 3 shillings 6.4 pence per ton. The tonnage milled is approximately 6,750 tons per week. The first recovery of metal contents is 54.9 per cent. The concentration was 4 to 1. Broken Hill mines, which were originally silver mines, are now classed as zinc mines.

Quicksilver Works in Austria

History of the Mines—Methods of Preparing and Refining the Ores

The following was extracted from M. Von Lipold's article on the Imperial Quicksilver Works, at Idria Krain, Austria.

The leading foreign quicksilver mines are the Almaden, in Spain, and Idria, in Austria. The Almaden has been worked for hundreds of years and is still producing largely. From 1864 to 1875 its output was 3,482,758 flasks, a flask being about 75 pounds avoirdupois. The Idria mine was discovered in 1490, or 1497, and next to the Almaden has furnished the greater part of the world's quicksilver supply for nearly four centuries. Since 1850 the California mines have contributed one-half of the total supply.

The discovery of quicksilver at Idria is said to have been made by a cooper, who placed a tub in a spring, where the metal adhered to it. In the rocks containing quicksilver are fossil imprints which place their age as Triassic; it is presumed, however, from numerous fissures and disturbances in these rocks that the solutions which deposited the metal were of the Tertiary period, as in California.

In Idria the ore deposits occur along the line of a great fault. In one place it is associated with conglomerate as a bedded deposit; in another place it occurs as a vein between a shattered dolomitic limestone foot-wall and a shattered chalky conglomerate deposit impregnated with cinnabar as a hanging wall. Below the dolomite are slates and these too contain ore. The ore occurs as a stockwork in the limestone and dolomite, showing that previous to its deposition those rocks were shattered, and since they are Triassic there does not seem to be much doubt but that the solutions occurred during the later Tertiary period. The slates are the principal ore carriers, though not uniformly or continuously; the cinnabar being in layers, in cracks, in pockets, and in lenticular-shaped masses; in other words, wherever the slates were distorted and the solutions could find an entrance the cinnabar was deposited. The metal is found as native quicksilver, in the form of cinnabar; as steel ore containing 75 per cent. quicksilver, which occurs in compact and granular form. The liver-colored ore is dense and shining, forming pockets in the steel ore. What is termed brick ore is bright red and sandy granular, with crystalline cinnabar disseminated through its mass. This ore is found principally on the boundary of rich masses where slates are not so fractured. A special variety of brick ore is termed "coral ore," which occurs where slates are dark and contain coral-like fossils. Pyrite commonly accompanies the ore, as it appears to be indigenous to the slate. It is said that wherever the slates are ore-bearing they carry organic matter, which, when concentrated in places forms a resinous substance known as idrialite and appears with the "liver" ores. The ore filling in the shattered limestones and dolomite of the northwestern region is of crystalline cinnabar, appearing partly in the limestone and partly in the cracks of the dolomite in all directions as thin veins, incrustations, nests, and in thicker layers. These rocks are particularly rich where they are between the slate beds, and then at times they contain native quicksilver. Globular segregations of pyrite on the faces of the strata are sometimes impregnated by native quicksilver.

One of the rich fissures upwards of 3 feet wide, consists of calcareous or slaty masses, richly impregnated with crystalline cinnabar and often with "steel" and "brick" ore. It is richest at the junction with another fissure. From these fissures the cinnabar extends far into the hanging and foot-walls. No other mineral occurs with the cinnabar except pyrite, although there is a little calcite, dolomite, and quartz. Idrialite and anthracite are found only in compact masses. Calomel is said to have been observed.

It seems conceded that the cinnabar ores of Idria were deposited from aqueous solutions. The rocks in which they are often distributed as incrustations show no traces of high temperatures, such as sublimation would require. The limestone and dolomite, in whose crevices the cinnabar is deposited, would have experienced a change at a high temperature. The Idria ore deposit increases with size in depth showing the fissure was filled from below. The solution naturally passed upward between the bedding of the slates and spread itself out in the bordering fissures and hollow spaces of the broken lime and dolomite and deposited its cinnabar there.

The beginning of mining was near the site of the present Holy Trinity Church on the northern side of the valley slope, but in 1500 prospecting was carried to the southern declivity, and in the bottom of the valley a shaft in 1508 struck a rich ore deposit, called the Achazi shaft, and the company was called the company of St. Achaius. The shaft is on the old school square. The Catherine shaft was opened by the reigning Prince in the same valley, also the George shaft. The shafts attained almost 500 feet depth. In 1709 a tunnel was begun to explore the southern slope, and another for the exploration of the northern slope, but without success. Several other unsuccessful tunnels were undertaken.

The quicksilver mines of Idria consist of 23 single claims. This extensive mining district is worked by six shafts and two tunnels. The ore is opened on 12 horizons or levels, with drifts for a distance of 4,500 feet, and by cross-cuts for a width of 1,720 feet. These levels are connected with the main shafts and inclines. The sum of the length of the drifts is about 67,589 feet. The method of working some of the deposits is by floor mining with stowing. The mass to be mined is cut into rectangular blocks by drivages 6.5 feet high, which run from the cross-cuts to the middle beginning at the extreme north and south limits, avoiding at the same time the entire removal of the barren part of the deposit near the main levels. The roof is supported by timbers 3 feet apart, made safe by adled waste material or stowing.

After the complete removal of this layer, the stoping of the next 6.5-foot high course, or floor above, is undertaken from the main levels and numerous upraises are made to the next higher floors; so the next higher floors are opened and filled up in the same order as if worked by overhand stoping. The yearly amount of excavation is about 40,800 feet of solid material, corresponding to a working area of about 20,400 square feet. The output has a metallic content of about 63.5 pounds of quicksilver for 35.3 cubic feet of solid material. The still remaining ore mass would, at this rate, last 70 years.

The filling of the worked-out portions is accomplished by using the material from the drifts and prospect tunnels, and also the material broken in widening out work by mason and timberman.

Ore dressing at Idria originally consisted in sorting the ore by hand picking, and screens, and washing in troughs.

In 1696 a stamp battery was erected and in 1736 an improvement in stamping, washing, and concentration took place.

The product from the mine was separated into three kinds with long unpronounceable German names.

The ore to be washed was treated on screens with water, then concentrated either by being picked over, if coarse, or by being sifted, if fine, or washed on inclined hearths if very fine. The material separated for stamping, together with the poorer residues from sifting, was crushed wet in a five-stamp battery, and the pulp, partly sorted by troughs, was concentrated to "slick," partly on inclined hearths, and partly on percussion tables.

The order of dry preparation of the mine product is as follows: The broken ore is separated in the mine into ore, ore to be concentrated, and waste. At the shafts are grizzlies upon which the ore is dumped to separate the fine from the coarse. The coarse ore is broken by a Blake crusher. Beneath

the crusher are sieves and a revolving table which further separates the sizes.

Rich and poor ores are stamped in a battery and again passed through various sieves and stamps, and finally go to the reduction works.

Originally quicksilver was won by a simple washing of the ore upon sieves, and then roasting in heaps. The ores were piled in alternate layers with wood in heaps, covered with turf, and set on fire. After extinguishing and cooling, quicksilver was obtained, partly free and partly from washing the roasted material in which it had condensed. In the 16th century, the ore was placed in earthen vessels, one over the other in pairs, and heated by an open fire, first uncovered, then covered.

In 1668 retort furnaces were built, and later seven vertical fume furnaces with masonry condensation chambers. In 1842 continuously working reverberatory furnaces with inclined iron condensation tubes, cooled by water, were made. Five of these furnaces were built, and later muffle furnaces were introduced to burn the soot.

The well-known fact of the penetration of the furnace walls and condensation chambers by metallic quicksilver, and its combinations, confirmed by the pulling down of old furnaces, gave rise to the introduction of iron shells with a light lining of masonry, as also of light wood and masonry constructions for condensation chambers, together with tubes cooled by means of water. So the evolution has gone on to the present state of perfection whose details are too elaborate to describe in this paper.

The products of the treatment of the ore are: (a) Metallic quicksilver; (b) soot, a mixture of quicksilver and chloride and sulphide of quicksilver, quicksilver oxide, flue dust, and various distillation products of the ore; (c) rich rubbish from masonry and wall scrapings.

The quicksilver from (a), without further refining goes directly to the bottling room.

The soot is treated first

mechanically, by which means the quicksilver is extracted; and residues from the pans with the rich rubbish (c) from masonry and wall scrapings are added to the furnace charge.

One of the valuable products derived from quicksilver is vermilion. This, as first manufactured in Austria, was merely pure pulverized cinnabar ore; later it was produced by sublimation of the ore.

The process of manufacture of vermilion from dry ore requires one stamp battery; one amalgamating plant with 18 small barrels; four sublimation furnaces, with six retorts of cast iron; four vermilion mills, each driven by 2.5 horsepower; kettles and vats for heating, digesting, and refining ground cinnabar; and one drying hearth.

The preparation of vermilion for commerce consists of:

1. Preparation of raw material.
2. Sublimation, i. e., preparation of cake cinnabar.
3. Grinding of cake cinnabar, refining and drying vermilion.

Three sorts of vermilion are manufactured: H. R. = high red vermilion; D. R. = dark red; C. = Chinese.

From the mill, cinnabar is refined by digesting it in potash lye. It is then washed and dried, sifted and packed in tanned sheepskin packages, a pair of which are placed in a wooden keg.

In the United States vermilion, which is an artificial sulphide of mercury, is manufactured at Baltimore and Philadelphia. There are numerous other red pigments, but genuine

quicksilver vermilion is known as "quicksilver," "California," or "English" vermilion. It is better than the imported article. Domestic vermilion is made from California quicksilver, or from foreign metal. The process consists in bringing quicksilver, sulphur, potassium hydroxide, and water together in a revolving drum. The mixture is gently heated until 115° F. is reached, the temperature is then kept constant, and the reddening action proceeds. Composition of vermilion is approximately, mercury 86.3 parts, sulphur 13.7 parts. There are many other vermilion products produced from various elements, but none are said to be so permanent and rich as quicksilver vermilion.

采 采

Rotary Tray Concentration

A New Form of Concentrating Table that Has Been Used in Some of the Mines of California

By Al. H. Martin

From the earliest days of California gold mining, the canvas table has played an important part in the advancement of the industry. Not only has it contributed largely to success in the California gold fields, but it has pioneered the way for the design

of many of the modern concentrators now used throughout the mining world. Owing to the low grade of the ore, and its free-milling qualities, milling practices on the Mother Lode, California's principal gold producing belt, manifest little variance from methods employed in the days of the Argonauts. The average of Mother Lode ore runs about \$5 per ton, consequently there has been little incentive for endeavors to improve milling methods, as the ore yields readily to stamp crushing, amalgamation, and concentration on Frue vanners and canvas tables. It is largely because of the free milling nature of the ore that modern milling progress has been

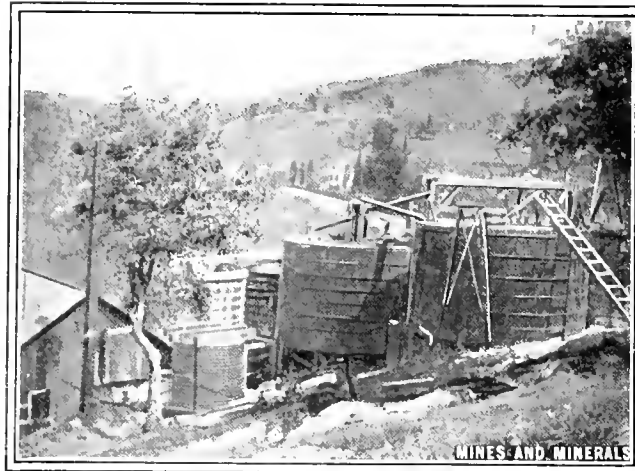

FIG. 1. DARROW-HAMBRIC PLANT, BUNKER HILL MILL

so little influenced by California experience.

For years the ordinary canvas table was exclusively employed to save the fine gold that had passed the vanners, and usually it achieved excellent results. The attention of many Mother Lode metallurgists has been centered on the improvement of the canvas table, and the Darrow-Hambric table is one of the results. The first table was installed in 1908, but the principal improvements have been made during the past year. The table has superseded the old canvas plants at four of the large mines of the Mother Lode, and is claiming attention from other gold mine operators.

The table or buddle, as shown in Fig. 2, consists of a series of broad sluices mounted on a circular frame, usually having a diameter of 28 feet. The tables are arranged in decks with 21 to 24 tables or trays to the deck. Each tray is 4 feet wide by 3 feet long, giving each a surface area of 12 square feet. Each machine has from six to ten decks, the number of trays varying according to size from 126 in the smaller to 240 in the larger. In some instances two machines are employed. The smaller buddle gives a surface area of 1,512 square feet, and the larger an area of 2,880 square feet. The circular frame is mounted upon an upright axis at the centre, with arms radiating to the outer circle. The frame is rotated by means of an encircling rope passing over a driving pulley, operated by a waterwheel, or other motive power.

The first buddles constructed had canvas-covered trays, but in the later designs a radical change has been made. In some instances

asphaltic felt is employed, while in others the plain lumber surface is first covered with asphalt paint and then coated with fine sand. In both cases it is stated that results have been more satisfactory than where canvas was employed. The sand-coated tables will not collect as heavy loads as the canvas or felt surfaces, but it has been found that by rotating the buddle rapidly enough, the sanded

charging into a settling tank, by means of a spray from a perforated pipe. The entire operation is automatic and continuous, requiring practically no attention.

It is understood that these machines effect a recovery exceeding 60 per cent. of the assay value of the tailing as it comes from the mills. That a higher rate is not obtained is due to the gold being in the coarse sand, from which it can only be released by fine grinding. It is understood that the gold carried by the tailing permitted to run waste assays around 60 cents per ton, but no attempt has ever been made on the Mother Lode to recover this, the companies apparently considering regrinding is not justified by the small amount going to waste. It is thus apparent that the concentrating machines are somewhat handicapped, but operators appear satisfied with general results.

The Darrow-Hambrie system of concentration is the patented invention of two metallurgists of long experience on the Mother Lode. W. E. Darrow was largely responsible for the success attending the canvas plant at the Golden Gate mine, near Sonora, while P. Hambrie built and operated the Gates canvas plant at the Zeila mine, Jackson district.

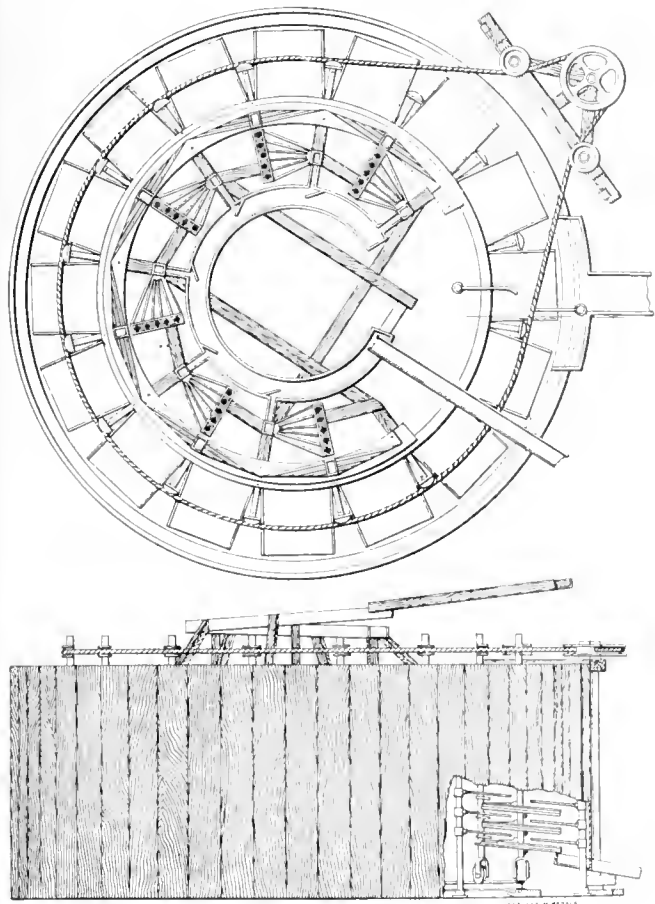

FIG. 2

surfaces speedily become filled with the fine sulphides. It is claimed that the sanded surface tables recover a larger quantity and a cleaner product than the fuzzy materials; also they have proven particularly valuable as a cleaning agency, and in conjunction with the felt-covered trays, effect a high average saving. At one mine the product is subsequently treated by agitation in weak cyanide solution in Pachuca tanks. At this plant no effort is made to clean the concentrate on the tables, the sweeps only running \$10 to \$15 per ton.

The superiority claimed for this buddle over the ordinary canvas table consists in its automatic operation, the cleaner product obtained, the elimination of the labor required in the average canvas plant, and its practical indestructibility. In designing the machines the inventors have utilized every opportunity to reduce operating costs and effect at the same time the highest possible recovery.

In operation the pulp from the classifying cone is divided by "spreaders" on the inside row of each deck of trays, insuring the even flow so necessary to achieve successful results. The tables incline slightly toward the centre of the machine, the inclination being generally about 1 1/4 inches to the foot. The grade is regulated at the pleasure of the operator, and any tray may be taken from machine and replaced with another at any time. The feed is automatically regulated, being shut off at a certain interval as each section arrives at the point of the feed discharge. Movements are so arranged that each deck of trays makes one revolution in 15 to 20 minutes, the sand-coated tables being operated at a more rapid rate than the felt or canvas-covered trays. After the tray is loaded a gentle current of clear water is run on it and the lighter sand is washed away. The concentrate is deflected into a launder, dis-

采 采

Cutting and Bending Glass Tubes

There are frequently occasions when mining men who have had no practical experience in using glass tubes can use them to advantage in experimental work, if they are properly informed as to their adaptability. Their advantages are transparency, ease with which they can be worked and shaped when hot and plastic, and the fact that they resist the action of most chemicals. If for any purpose it is desired to cut a glass tube, the operation can easily be performed with no tools but a sharp file and the hands. With the file make a nick in the tube at the desired point, then hold the tube in both hands, the two forefingers together, immediately under the nick, and the two thumbs above, as shown in Fig. 1. Turn the wrists outward and downward, around the forefingers as axes, and the tube will break at the place nicked by the file.



FIG. 1

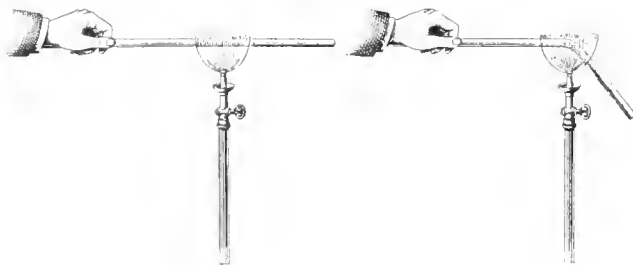

FIG. 2

FIG. 3

If it is desired to bend a glass tube, the method most frequently used is to hold it lengthwise along a flat gas flame of fish-tail or bat's-wing shape, as shown in Fig. 2. Keep it moving slowly round and round and also to and fro. As soon as it gets slightly soft, hold it by one hand and cease rotating it. The free end will gradually fall, as shown in Fig. 3.

As soon as it is bent to the desired angle remove it from the flame. A fault of this method is that the glass is likely to bunch at the bend and partly close the tube. If the tube is held at both ends, and as soon as the glass softens, it is bent upwards, a smoother and more uniform bend is secured.

Geology of the Breckenridge Placers

Large Deposits of Gravel and Boulders—Description of the Methods Used in Working Them

By Arthur Lakes

Near Breckenridge, Summit County, Colo., hydraulic and placer mining has been carried on many years, and in the later years gold dredging as well; in fact, the gold gravel in the vicinity of Blue River has run the gamut through gold pan, rocker, sluices, high-line ditches, hydraulic nozzles, elevators, booming, dredging and many experimental machines that have been found wanting.

The Evans elevator was tried and experimented with several years, but was unable to deal with the great boulders found in the gravels. An effort was made to overcome the difficulty of the large boulders, some of them 6 feet in diameter and weighing many tons, by the instituting of cranes, but the labor and expense connected with these auxiliaries to the elevators and hydraulic pipes were

these may be seen at intervals along the Swan River. Finally powerful bucket dredges were built and these, both on the Swan and Blue rivers and on French Creek, have proved eminently successful. But before all these were the hydraulic miners with their rockers, sluices, and giants, who as early comers into the region reaped a rich harvest from the upper benches composed of softer and finer gravels. These sometimes varied from a few feet to nearly a hundred in depth, and were extensively worked both on small and large scales. Some are still worked with giant nozzles and others are contemplating resuming business, the ground being far from worked out. The main necessity in working these grounds was an abundant supply and force of water. This was obtained by bringing long pipe-line ditches and flumes above the banks, and by tapping the headwaters of the Blue River and other tributary streams. Many miles of these ditches and flumes can be seen high up along the flanks of the mountains. The placer workings, of course, had to be below the level of these ditches, and their progress into the banks was limited often by their position relative to these, rather than to the banks of gravel giving out or the gold failing,



FIG. 1. PANORAMIC VIEW OF BLUE RIVER PLACER AND DREDGING GROUND



FIG. 2. TEN-MILE RANGE, SHOWING CIRQUES AND CAÑONS; ALSO THE HIGH TERRACE PLACERS ALONG THE BLUE RIVER

found so costly as to overbalance the profits that might be attained by the elevator proper. In the upper part of the Blue River, about half a mile south of town of Breckenridge, where this system was put to its severest test, the depth to bed rock was found to be upwards of 75 feet. Down the river this lessened as a rule, but with variations to about 40 or 50 feet. Next a curious-looking machine was tried, known as the clam-shell digger, which consisted of a sort of double scoopshovel with locking teeth in two sections, the whole—when the compartments were closed—comparable to a shellfish such as the clam. This, by the aid of machinery—a beam and crane—dove down into the debris and bore up the material between its closed jaws reeking with mud and slime and dripping with muddy water and deposited it in a sluice. This ingenious machine, after a brief trial was found wholly incompetent to tackle the boulders, which often clogged its jaws, preventing them closing, and so spilling all the finer matter containing the principal gold. The relics of this device now stand on the banks of the Blue River as a monument of failure. Next in order some small bucket dredges were tried, but their machinery and buckets proved far too small and weak to contend with the boulders. Wrecks and relics of

After working these banks considerably and obtaining much of the "cream" of the easily obtainable gold from them, the placer miner's work ceased, as he was unable, with his appliances, to attack the gold which might be in and at the bottom of the great river beds and flat river meadows. This was left for the domain of the dredge. Thus it would appear there are two forms of alluvial gold mining represented in this region, one composed of the high banks and terraces of gravel and fragmentary rocks extending on either side up from the river and river meadows for sometimes 1,000 feet on the flanks of the mountains; the other composed of river beds, bottoms, and river meadows only. The former was strictly the domain of the hydraulic miner, the latter of the dredges and kindred devices, including, by the way, lately a sort of steam-shovel apparatus combined with some of the mechanism of a dredge being tried near Dillon, a few miles south of Breckenridge, on the Blue River.

The origin of the large boulder gravels, such as occupy the cañon of the Blue River to a point a short distance south of the town of Breckenridge, is due to glacial action, whilst that gravel occupying the bed of the Blue River for some miles, as well as underlying the flood plain meadow of this stream, are probably the result of com-

bined glacial and river action or a modification of the latter by the former, or may be wholly due to the former. On the other hand, the high terrace gravels would appear to have a somewhat different origin, or a modification of those mentioned. The evidences of glaciation are in the 10-mile range of mountains, particularly in the cañon of the Blue River leading up to the headwaters of that stream at the Hoosier Pass, a divide which separates the headwaters of the Platte on the west side from those of the Blue and its affluents on the east side. The unmistakable evidences are huge amphitheaters near the crest of the range, where the ice first collected and from which the tributary glaciers started on their downward course to join the main glacier occupying the upper part of the Blue River. This main valley has the typical U shape of valleys once widened and filled by a glacier. Lateral rock spurs are truncated and smoothed off. The bed rock in these valleys, as well as projecting points and benches over which the glacier passed, are polished and ground. Lakelets occupy rock basins hollowed out of the solid rock by the pounding of the ice, or are formed by the drainage of the cañon being dammed back by a moraine. The valleys contain lateral and terminal moraines, and large ice-borne boulders are dropped and remain poised at points high above the bottom of the valley, where ice only could possibly have left them. These and several other signs show unmistakably the extensive former existence of glaciers in this region.

According to S. R. Capps, Jr., in Bulletin 386, United States Geological Survey, the ice of the last epoch of glaciation covered by far the greater part of the surface of the mountains in the higher parts of the ranges. Here only the narrow crests of the ridges projected above the ice from this collecting and continuous field of snow and ice on the crests. The glacial ice moved down the mountains. The ice was deepest in the larger mountain valleys, each occupied by a glacier with ice tongues extending down the slopes and even into the river meadows.

A system of glaciers, according to Capps, occupied the valley of Blue River from its head to a point half mile north of Breckenridge. It had a maximum length of 12 miles and an area of 14 square miles, and was formed by the ice from four cirques from the west joining in the valley of the Blue River. No ice, he thinks, was contributed to this system from the east, probably because the mountains on that side are not as high as those on the west.

The principal tributary glaciers were from Spruce Creek, Quandary, and Monte Cristo side gulches. The main valley of the Blue River from the Hoosier Pass to its terminal moraine just above Breckenridge is everywhere covered with heavy glacial drift of large boulders.

Beyond the terminal moraine, the Blue Valley is filled with gravels, which form the seat of the hydraulic placer mining industry. These gravels extend up a mile or more on the flanks of the 10-mile range below Breckenridge for over 1,000 feet vertically, and for a thickness of over 100 feet. They extend also on a minor scale along the lower hills on the east side of the Blue River and up several of the tributary valleys on this stream. The gravels do not extend as high as on the opposite mountain side, nor are they so deep, rarely exceeding 60 or 70 feet to bed rock. The boulders in these gravels are much smaller than those in the true glacial area, and are angular and subangular, rarely rounded or showing river or water action.

Whilst a large majority of the high bench or terrace placers worked in early days have been permanently or temporarily abandoned, some being worked out, others having reached the limit of the water-supplying ditch or flume, there are others that are only temporarily idle, with all appliances on the ground ready very soon to resume work; others are still working on portions of old notoriously rich ground, and a few have opened up and are working new and untried ground. Those who worked in various ways these high bench placers in early days probably reaped a rich harvest, although there are no very reliable records of what they actually obtained. Some of the side-gulch placers, such as Gold Run, the Peabody placer, and those of French Gulch have a reputation of having produced many millions, and a vast number of nuggets having been

found varying in size from that of a walnut to others several pounds in weight and in value from a few dollars to many thousands. Some of these nuggets were considerably water worn, others were flattish and showed little attrition, and still retained evidence of their crystalline origin and structure, the latter usually attributed to leaf and crystalline gold found in place on Farncombe Hill. There has also been considerable variation in the fineness of the nuggets found in different gulches, some being quite low grade and very light in color and much alloyed with silver, having a fineness of not over 16 per cent. Others again attained a fineness of over 90 per cent. and were of nearly pure yellow gold. A few were found still embedded or clinging to fragments of quartz; the majority were free from any stony matrix. Some doubtless originated from quartz veins in place, others from gold disseminated in breccia or in decomposed porphyries, others in zones of auriferous quartzite.

Prominent among the great excavations into the hillside gravels is the Banner placer on the west bank of the Blue River, and on the vast amount of gravels extending for many thousands of feet up the eastern face of the 10-mile range about 3 miles below Breckenridge. These gravels were worked in early days by primitive appliances, but it was not till Colonel Kingsbury, of Breckenridge, in later years took hold of them, that they were developed on a large scale, with flumes, sluices, giants, and other up-to-date appliances.

About 2 miles below Breckenridge there is a long ridge capped with nearly horizontal Cambrian quartzite. On this formation is the Iron Mask mine, which has produced in the past a great amount of gold-bearing ore. A mile or more across Cucumber Gulch from the Iron Mask, and nearly opposite, there is a rounded gently sloping hill containing at about its center the workings of the Banner placer. This rounded hill is profusely scattered over with angular fragments and boulders of the same quartzite as that overlying the Iron Mask mine and capping Shock Hill. Amongst these are numerous blocks of oxidized rusty quartzite assaying well in gold and silver that would be called rich looking float. This quartzite ceases higher up the mountain, where granite debris alone is found. It would seem probable that the whole of Banner Hill was at one time capped by a body of gently dipping gold-bearing quartzite, in which were either zones, blanket veins, or pressure veins oxidized and carrying gold. This quartzite cap was gradually broken up *in situ* or with but little transportation and was disintegrated by various surface agencies, such as frost, snow, ice, and periodic freshets, issuing from the mountains above.

At the summit of the hill are the well-built cabins of the company, equipped with electric lights, etc., operated by electricity generated from the flume and pipe supplying power to the placer. Close to the cabins is the edge of the vertical cliffs of the placer. Looking down from here the great excavation is seen that was made by the united forces of booming, a cutting ground sluice, waterfall and stream, and by auxiliary hydraulic giants. The section of the deposits as shown at this point was, beginning with the grass roots, 2 feet of white sandy material composed of comminuted fragments of quartzite said to average from 75 cents to \$3.25 gold per cubic yard, sufficiently rich to have in former days been worked by surface miners in what are locally known as "shin" or "skin" shallow diggings and found to be profitable at the rate of \$26 per day per man, even after paying a royalty of 50 per cent. Below this is 6 feet of gravel containing angular quartzite boulders and fragments sometimes cemented by iron oxide. This zone was said to carry from 36 to 40 cents in gold on an average per cubic yard. Below this to the stream bed is almost 70 feet of unsorted gravels with quartzite boulders also carrying gold. Bed rock has not yet been reached but is believed to be about 20 feet below the present stream bed, making the thickness of the deposit about 100 feet. This body of gravels shows occasional lenticular bands and splashes of clay and finer gravel, but there is no sign of regular stratification or other indications of its having been deposited in still water or in continuously running water. Gold has been found at bed rock where the latter, consisting of upturned gneiss, was found lower down the placer exposed near the Blue River. Although bed rock has not yet been found higher up the placer, Colonel Kingsbury

hopes soon to reach it by the steady force of his waterfall and ground-slucice stream cutting at the rate of about a foot per week. Colonel Kingsbury intends to increase his present waterpower by making a reservoir high above the placer with capacity of 300,000 feet of water and a 700-foot fall. By letting this body of water go suddenly in what is called "booming" from time to time, he expects to cut very quickly to bed rock, where it is believed, as in other placers, the richest gold is most likely to lie. The present water is about 40,000 miner's inches with fall of $4\frac{1}{2}$ per cent. It is conveyed from a ditch and flume lying on a natural bench or plateau to a steel pipe 1 mile long with diameter 22 to 24 inches, tapering toward the placer where there is 1,000 feet of 9-inch pipe to which the giants are attached. Two side pipes also issue at an angle from the main pipe toward the placer pit, where great nozzles are attached to them.

The present source of the water used lies in the watershed along the base of the upper portion of the mountain for about

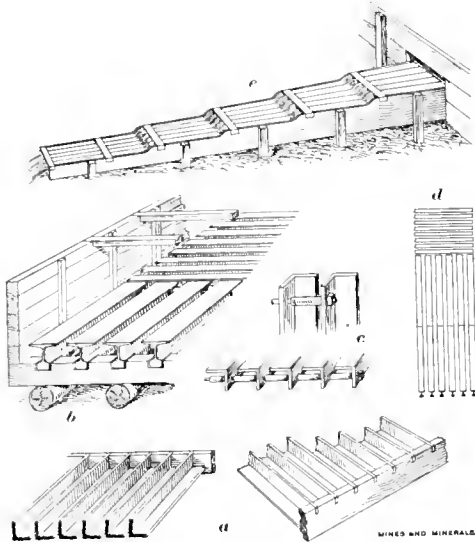

FIG. 3. RIFFLES AT KINGSBURY PLACER
a, Angle Iron Riffles; b and d, Arrangement of Riffles;
c, Vibratory Riffles; e, Bent Metal Riffles

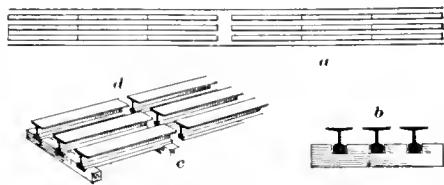

FIG. 4. RIFFLES AT STOFER PEABODY PLACER
a, Plan; b, Section; c, Riffles Showing Space
for Nuggets at d

6 miles. From this there are ditches and flumes; one of the principal is called Cucumber Ditch. The face of the mountain, following up the course of the pipe line west, rises gently to the base of a ridge or plateau about 50 to 100 feet high, on top of which is a small lake. Down the face of this ridge the pipe line under great pressure descends at a moderate angle and continues down on the gentler slope to the head of the main placer. There is also an open ditch leading to the ground-slucice waterfall at the head of the cañon, being cut back from the main excavation of the placer. The area occupied by the placer with its several arms, side and parallel excavations, is 1,100 acres, 600 of which are patented.

Above the present pipe line and ditch is a peculiar country, abounding in glacial hummocks, some containing small ponds or lakelets. These are capable, with a little artificial damming, of forming a large reservoir that will supply the power required for booming or placer mining throughout the greater portion of the year. At present there is a good force of water from the spring months to August and September, when the water is apt to slacken.

Gold nuggets have been found plentifully at different spots in the placer, all being waterworn and slightly flattened, but none showing a crystalline structure. One nugget is said to have weighed over 6 pounds, valued at \$17.50 per ounce. Colonel Kingsbury has taken out and retains some weighing over 6 ounces. Gold in the placer is what is known as "shot gold," although fine gold also occurs. A peculiar feature of the placer is the great amount of "float" found in blocks of oxidized quartzite, doubtless derived from quartz veins. If it results from fissure veins they will be uncovered as the development increases.

In the lower part of the placer are the flumes, undercurrents, riffles, sluices, and giants. In these are several patterns and varieties of riffle used, Fig. 3, some being the inventions of Colonel Kingsbury. One in particular is called by him a vibrating riffle in which the angle irons instead of being rigid, as commonly, are loose, and by aid of a swivel have a vibratory movement which the inventor claims to have found very successful in arresting and depositing the gold, and particularly in disposing of the choking "black sand." All these different patterns are mainly endeavors to imitate the natural rock riffles found in the bed of the streams. Another arrangement of riffles are the bent or step riffles composed of angle irons bent at one end to simulate in the undercurrent the slight irregularities or steps in a stream bed over which the flowing water carrying gold-bearing gravel falls and partly deposits its burden. Both mine rails and angle irons, as well as steel strips nailed on to wooden slats, are used. The mine rails are placed upside down to what they are in a mine track or railroad, the broad portion or plate being uppermost. In the main sluice there is an alternation of railroad irons running parallel and placed longitudinally with steel-plated wooden riffles or strips placed horizontally or at right angles to these. All these ingenious devices aid more or less the precipitation of the gold at various points of the sluices.

Stofer & Jaycott Hydraulic Workings on Peabody Placer in Gold Run.—Gold Run is a wide shallow valley, the pathway of a stream. On either side, but especially on the south, are remnants of high bench placers extending back to the quartzite ridges dividing the drainage of Gold Run and the adjoining Swan River from that of French Creek further south. The run has been the scene of extensive hydraulic mining in the past and a large portion of the available gravels have been worked out below the high-line ditch and flume above them. Some rich portions, however, have been left, and these on the lower part of the ravine, on what is known as the Peabody placer, are being worked by giants and sluices.

Source of the Gold.—About two-thirds of the way up the river is the Jessie mine, which at one time produced much free gold in a brecciated zone of porphyry. It is notable that below this mine and brecciated dike of quartz porphyry the placers were found prolific in gold, while above this zone the bench placers or gravels were found notably barren. The Run is underlaid by gently dipping shale traversed at intervals by decomposed sills of quartz-porphry. The gold is commonly most abundant in connection with these decomposed porphyries where the workings cross them. On the hill south of the river are located some notable gold mines, such as the Jumbo, whose ores were likewise associated with porphyry, whilst beyond them is a long ridge of quartzite similar to and of the same age as that on Shock Hill and at the Iron Mask mine, and which appears to have yielded much of the gold of the Banner placer.

The bank of high terrace gravels attacked by the giants of the Stofer placer mining is about 70 feet thick or deep to bed rock, which consists of uplifted shale forming natural riffles. The bank stretches back south upwards of a mile to the great dividing ridge of quartzite and the material forming the gravels as well as the angular pebbles are all of this quartzite. The angular boulders lying in the yellow gravel are rarely large. On the north bank of Gold Run, opposite the placer, a large sill of quartz porphyry is seen traversing the shales diagonally. It is expected when this is crossed in the placer that the ground will be rich.

The mode of working the placer is by two giants supplying material to a wooden sluice below them. It is 100 feet long, lined

with mine-rail riffles placed longitudinally like Hungarian or pole riffles. A wide steel pipe brings down water at high pressure from a high-line flume and ditch on the hill above, about half a mile distant from the placer. Both giants, one a few feet above the other, play on the gravel at bed rock convergently, endeavoring to undermine the cliff of gravel and precipitate it in large masses into the ground-slucice waters which lead to the main or wooden-riffled sluice. From the upper giant a continuous stream of water pours down the bank of loose debris, whilst the lower giant, located about the level of bed rock, assists both in undermining the cliff and in pushing along the debris into the mouth of the wooden sluice, where the gold is precipitated by aid of mercury and arrested in the riffles. The riffles are made of mine rails placed upside down so that the broad top or plate is exposed for catchment. These railroad irons are in short longitudinal sections placed as before described.

Between each section of rails or set of riffles a small space *d*, Fig. 4, is left for catching nuggets. The rails are inserted on 4"×4" timbers at intervals of every 4 feet. The rails are set into the cross-piece of 4"×4" timbers to a depth of 1½ inches and kept in place by wedges. Below them is a small space to act as a sort of miniature under-current. The railroad irons are 16-pound rails.

The water pressure is 1 pound to every 2 feet elevation, or 100 pounds to every 200 feet elevation. In the penstock of the flume is a screen or grizzly for arresting and keeping out floating rubbish. Along the pipe from the penstock are air-relief stations at long intervals.

At present three men are at work. Cleanups are made at intervals of about a month; the trouble of taking up and laying down again the riffles is considerable and causes delay. The gold, after being retorted, is placed in the city bank.

The Peabody placer, though generally accredited with being rich, is inclined to be spotty and uncertain. The values are commonly at or near or within bed rock, that is, a foot or so below the surface. A rough porphyry bed rock is better than a smooth shale for gold. From the workings we can look down the Run to Swan River and see the dredges and dumps of the Colorado Dredging Co.

At the headwaters of Swan River, near the east base of Farncombe Hill, the Snider placer has been working for some time on bench gravels about 30 feet thick. At first the placer was worked by a tunnel driven in on bed rock and the gold gravel ground sluiced. At present, in addition to this are two giants. The placer is said to be rich and the gold, coarse and crystalline, is supposed to be derived from Farncombe Hill above it. Besides the Banner diggings on the west side of the Blue River, is the Jackson placer, a few hundred yards directly west of town, running several hundred

yards back on to the hill of bench gravels. A characteristic feature of this placer, as compared with the Banner, is the prevalence of decomposed quartz porphyry boulders. Opposite the Banner, across the Run, are the old Yuba Dam workings. Proceeding north down the river are the old Gold Hill workings, a little below the confluence of the Swan and Blue rivers. All these placers have produced their thousands, or even millions, in their day.

It is a noteworthy fact that wherever quartzite fragments prevail in these placer beds, as relics of the old Cambrian auriferous sheet that once covered a large portion of this area, the placers are rich. About 10 miles down the Blue River from Breckenridge, near Dillon, is encountered a large area of placer ground lying between Ten-Mile and Willow Creek, which has been worked both by Evans elevators and by primitive sluices and rockers. A notable bank of this placer material is seen up Salt Creek on the flanks of Buffalo Mountain. The principal material of these placers is a quartzite of much later date than that further north, it belonging to outcrops plainly visible of Dakota Cretaceous overlaid and underlain by shale and marls. On the Salt Creek—Buffalo placer—the Briggs steam-shovel-dredge combination, is being at present tried.

采 采

Ore Mining Notes

Trail, B. C., Smelter.—The operation of the Trail, B. C., smelter was rendered quite expensive during the last few months because it was dependent on Pennsylvania coke for a fuel supply, but R. H. Stewart, general manager of the Canadian Consolidated Mining and Smelting Co., believes the next annual report of the company will show a material gain, both in profits and volume of business. S. G. Blaylock, smelter superintendent, announced in Spokane that the smelter is running at its full capacity. The lead side of the plant has a capacity of 250 tons a day. The copper side has a capacity of 1,500 tons daily, but never has been operated to a greater capacity than 900 tons, at which rate it is running at present.—A. W.

Dead Medicine Mine Rehabilitated.—It is reported the old Dead Medicine mine, on Clugston Creek, 16 miles north of Colville, Wash., which was a paying producer of lead and silver ore 20 years ago, under the management of Colonel I. N. Peyton, of Spokane, and which was abandoned as a worked-out project, has again taken its place among shippers of ore from the Stevens County district. Spokane mining men, who rehabilitated it under the name of the Clugston mine and have had it under development for more than 18 months, have run nearly 700 feet of tunnel and have encountered a full face of ore on the 450-foot level, nearly 200 feet below the

Zinc-Lead Production of Missouri, Kansas, and Oklahoma for 1911

Camps	Zinc Blende		Calamine		Lead		Total Value
	Pounds	Value	Pounds	Value	Pounds	Value	
Webb City, Carterville, Mo.....	189,376,352	\$3,828,906			49,239,545	\$1,428,076	\$ 5,256,982
Joplin, Mo.....	116,869,886	2,331,600	3,797,190	\$ 46,296	17,620,492	507,940	2,885,836
Galena, Kans.....	34,947,656	747,362	167,242	2,786	7,707,460	221,264	971,412
Duenweg, Mo.....	30,363,950	611,795	4,512,255	56,075	3,822,970	110,061	777,901
Alba, Mo.....	32,123,750	672,619			639,240	18,753	691,372
Oronogo, Mo.....	20,330,390	399,135			2,735,790	75,129	474,264
Granby, Mo.....	8,225,510	143,616	18,731,540	238,600	1,315,830	34,369	416,585
Miami, Okla.....	16,373,679	243,977			5,354,105	149,882	393,859
Spring City, Mo.....	4,871,505	104,131	5,594,040	66,601	1,925,890	50,114	220,846
Carl Junction, Mo.....	8,986,316	187,667			127,920	3,522	191,189
Aurora, Mo.....	6,824,935	131,836	3,556,755	42,618	162,700	4,571	179,025
Cave Springs, Mo.....	8,022,546	173,693			499,190	15,548	189,241
Quapaw, Okla.....	4,295,120	82,960	18,010	216	560,585	15,754	98,930
Carthage, Mo.....	3,052,350	61,417	43,800	5,347	82,370	2,244	69,008
Sarcoxic, Mo.....	2,235,210	43,800	622,310	7,210	12,150	330	56,340
Springfield, Mo.....	1,639,620	36,309			489,720	13,836	50,145
Badger-Peacock, Kans.....	2,401,580	47,675			82,100	2,054	49,729
Lawton, Kans.....	1,767,926	36,633			49,230	1,447	38,110
Stotts City, Mo.....	1,236,570	24,309					24,309
Wentworth, Mo.....	504,150	10,085					10,085
Reeds, Mo.....	286,470	5,650					5,650
Seneca, Mo.....			256,900	3,320	60,490	1,644	4,964
Peoria, Mo.....			222,750	2,724			2,724
Greenfield, Mo.....			197,670	2,005			2,005
Total shipments.....	494,631,471	\$9,925,145	38,133,422	\$473,798	92,487,777	\$2,656,568	\$13,055,511

old workings. The new discovery is believed to be the same ore shoot found on the surface. It runs from \$12 to \$70 in silver.

Quicksilver in Ontario.—It has been stated that quicksilver has been found on Ground Hog River 6 miles north of the Transcontinental Railway in Ontario. On the claim which has been staked the mercury is said to occur native in small globules and as cinnabar. The claim is to be worked with the assistance of Toronto capitalists.—C. N.

Coniagas Mine, Ontario.—During the six years that the Coniagas silver mine has been shipping ore from Cobalt, Ontario, it has sent out 10,582,128 ounces of silver. Of the 7,360.6 tons of ore shipped in that time, 2,489.9 tons was concentrate containing 3,193,492 ounces of silver. During the last fiscal year 52,320 tons of ore averaging 36.3 ounces of silver was milled, yielding 1,418.4 tons of concentrate containing 1,643,616 ounces of silver, while 619.1 tons of ore containing 2,142,536 ounces completed the total shipments of 2,037.5 tons.—C. N.

Cobalt Silver Deposits.—During the summer of 1903 men were building the Temiskaming and Northern Ontario Railroad to open agricultural lands beyond the district now known as the Porcupine gold field, and native silver was discovered by James McKinley and Earnest J. Darrow at the south end of Cobalt Lake. Early in 1904 the finds were extended and prospecting for silver was kept up continuously until 1908 when prospectors reaching out from Gowganda 51 miles found gold in the Porcupine fields. Since then silver has been neglected, although the possibilities for obtaining paying quantities of silver are better than of obtaining paying quantities of gold.

An Aerial Tramway at Cobalt.—The first aerial tramway for carrying ore in Cobalt has been installed and put in operation. It is nearly one mile long and connects the Crown Reserve and the Kerr Lake mines with the Nova Scotia mill. Each bucket carries 500 pounds and the capacity of the tramway is between 150 and 175 tons per day.—C. N.

Dome Mine Financed.—The Dome mine at Porcupine was taken over by the Monell Syndicate in March, 1910, who were to develop the property and build a suitable mill and cyanide plant. The syndicate spent over \$180,000 in development work and agreed to erect a mill costing at least a quarter of a million dollars for the treatment of its ore. This agreement is being carried out. The property was originally turned into the Dome Company, capitalized for \$2,500,000, the owners receiving \$50,000 in cash, \$450,000 in bonds, and \$1,500,000 in stock. Recently the capital was increased by \$1,000,000 and subscribed for at par by the holders of the original stock, which fund went into the treasury of the company. Of this amount \$450,000 was used to take up the bonds, the balance of the money to be used in development work. After all the agreements of the Monell Syndicate are carried out the company will have a mill and cyanide plant fully equipped, with a capacity of from 300 to 350 tons per day, no encumbrance against the property or company, a fully developed mine, and approximately \$200,000 in cash as an operating fund. The present mill will be running on or about the 1st of February.

Tungsten Concentrator.—W. A. Brockway, of Spokane, Wash., general manager of the Tungsten Consolidated Co., announces that a 60-ton concentrator is being built near Loon Lake, Wash., and that it is expected that by the time the mill is ready for operation there will be enough ore on the dump to pay for its construction. With 5-per-cent. mill feed the concentrator should produce 4 tons of concentrate daily, of an average value of \$500 to the ton. There is sufficient ore in sight now to insure the mining of 7,500 tons, with only a little more development required.

South Dakota Production.—The annual report of State Mine Inspector R. L. Daugherty shows the mines of the Black Hills of South Dakota to have had a most prosperous year for the 12 months covered by his report, from October 31, 1910, to October 31, 1911. During this period \$7,625,506 was extracted from 1,945,329 tons of gold ore and a quantity of placer gravel not tabulated. The largest producer was the Homestake mine, which made a bullion production valued at \$5,875,000 from 1,511,302 tons of ore. The

Golden Reward produced \$392,000; the Mogul, \$481,000; Wasp No. 2, \$295,000; Lundberg, Dorr & Wilson, \$75,000; New Reliance, \$31,000. Other producers of ore sold bullion to the value of \$379,000, and placer production is credited with \$83,000. The mine inspector gives the total of men employed in the mines at 3,974. In addition to the gold and silver production, there are important mica mines in Custer County, owned by the Westinghouse company, which were large producers; some galena ore was shipped to smelters; and lithia ores, including lepidolite and amblygonite, were marketed from the Keystone district. The figures show that the production is next to the largest ever recorded for the Black Hills, being exceeded only by 1908, when the gross production was valued at \$7,783,295.

Wasp No. 2.—A steam shovel, the first to be used in a Black Hills mine, is being installed by the Wasp No. 2 company at its property near Deadwood, S. Dak. It will be used for stripping the overburden from a gold deposit, ore from which has been successfully milled for a number of years. During the present year the mill has been handling from 14,000 to 15,000 tons per month, the average recovery being less than \$2 per ton in the cyanide mill. Operations are so well managed that monthly dividends of 2 cents per share, or \$10,000, have been maintained. The mine is an open-cut proposition, and the company intends to install another shovel next spring for handling and loading ore.—J. S.

Sixty-Mile River Placers.—With the thermometer -40° F. several hundred prospectors left Dawson, Yukon Territory, for the new gold discovery at the head of Sixty-Mile River. Many of these men are poor and started to walk the 130 miles to the diggings not named; it is probable, therefore, that a number will lose their lives. The reports are that the ground is fabulously rich and that more than one pan of dirt has furnished \$100 in gold at one washing. There are already several hundred men in the new fields or on their way. Supplies for saloons, gambling houses, a hotel and general store are being rushed over the trail to the new camp, which is yet to be named.

Election of Michigan Mine Inspectors.—Beginning next fall, mine inspectors both in the iron and copper regions of Upper Michigan are to be elected by direct vote of the people. This is provided by a law enacted at the last session of the legislature. Heretofore the mine inspectors have been appointed by the various county boards of supervisors.

The law establishes certain qualifications for candidates for the office. They must speak the English language, and, if practical miners, must have had at least 10 years experience in mining, timbering, and general underground work; if graduate mining engineers, they must have had 2 years practical experience. Mining inspectors in all iron and copper counties elected in the fall of 1912 will take office January 1, 1913. It is provided that all inspectors shall receive not less than \$5 a day and the assistant inspectors not less than \$3.50 a day for all time actually put in on their work.

The duties of the inspectors are explicitly set forth in a long section of the law. They are required to visit all the working mines in their jurisdiction at least once in 60 days and to condemn all places where conditions are found to be dangerous, reporting the same to the men in charge of the operations. The law provides that any men who are continued at work in places that are condemned by the inspector shall do so at the employer's risk.

As a matter of fact, mining men express no concern at the presence of the law in the statute books. They are bending all their energies to putting their mines in the best of condition against the day when the operation of an employer's liability law will make them bear directly the money loss that will arise from casualties in the workings. Thousands of dollars have been spent in Marquette County alone the past few months in the introduction of safety appliances about the mines and shops.

Green Castle No. 2.—The final act of dismantling the old Green Castle mill No. 2, on the Rex land, has just been completed. For several years the process of tearing down the plant has been going on, occasionally a small piece of machinery or part of the mill being taken, until at last all left of the plant is the frame shell.

The Giroux Mine Fire

Facts in Regard to Its Occurrence and the Methods of Recovering After the Fire

By H. H. Sanderson*

The Giroux shaft, of the Consolidated Mines Co., is situated at Kimberly, about 12 miles northwest of Ely in the heart of the copper district of eastern Nevada. With it is connected, at the 770-, 1,000-, and 1,200-foot levels, the Alpha shaft of the same company which will be remembered in connection with the rescue therefrom a year ago of three men who had been imprisoned behind a cave for 47 days.

The main, or Giroux, shaft, used as an upcast for the air, the Alpha serving as the downcast, is divided into five compartments. The largest compartment, used for sinking, is bulkheaded at the 1,000-foot level. a small engine at the surface hoisting the rock from the bottom of the shaft to the 1,400-foot level where it is transferred to other cages. The four other compartments are used as a manway, pipeway, and two for hoisting muck. To date, nothing but development work has been done upon the property. In addition to the three levels named above, there is a fourth at 1,400 feet, which, however, has been driven but 500 feet from the Giroux shaft.

The fire, which was discovered on the evening of August 23, last, is supposed to have started in the shaft between the 1,000- and 1,200-foot levels, its origin being unknown. Clarence Gates, one of the survivors, says that those of the shift working at the bottom of the shaft (which was some 50 feet below the last, or 1,400-foot, level) were ordered by Timothy Gilmore, the shift boss, to "come up at once." No reason was assigned for the command, but as the men decided from the tone of his voice that something was amiss they immediately hastened to obey. The shaft timbers being in place within four feet of the bottom, Ed. Knox, one of the shift, climbed up on these while the others waited for the bucket, which was hanging immediately above them, to be lowered. Knox reached the 1,400 level before his companion who waited for the bucket and at once went to the telephone to communicate with the topman. Failing to receive a reply from the surface it was supposed that the cable containing the telephone wires had already been burned. Finding no one at the 1,400-foot station and a glance up the shaft showing that it was ablaze, Gates seized the hempen bell cord to signal the hoisting engineer when it gave way under the strain, the dropping end being on fire. About this time the men heard an explosion which they then believed was that of the underground magazine, but which now seems to have been, in all probability, that of the box of detonating caps stored on the 1,200-foot level.

When the hemp rope broke Gates tried to pull the bell wire of the other cage, but required the assistance of two of the others before it was possible to give the danger signal in the engine room. Having received the danger signal and noticing the bell cord move, the engineer lowered the cage to the 1,400-foot level, and the men, having gotten on, gave the signal to hoist. The engineer, not knowing the location of the fire and probably believing that there might be men at the 1,200-foot station and that the guides might be damaged, hoisted very slowly and the occupants of the cage while passing through the zone of the fire were badly, some of them fatally, burned. Those sur-

viving the trip state that J. J. McNulty started with them from the 1,400-foot level. On the way up a jar was felt from which it is presumed that he fell from the cage at that time, as his badly mangled body was later found on a driving set a short distance below the 1,000-foot level. At the time the others left the 1,400-foot level on the one cage, it appears that Daniel Drae, the cager, was on the other (it being used in counter-balance) on his way to the surface to give instructions in regard to the fire. The fact that his body was found later on the ladder adjoining the cage compartment only 15 feet from the surface, together with the presence of his lantern on the cage itself would seem to confirm this belief.

While these events were occurring in the main, or Giroux, shaft, three men, John Wilhelmy, Thomas Odalovich, and Timothy Gilmore went along the 1,200-foot level to the Alpha shaft up which they attempted to climb on the vertical ladders. The turning on of the sprinkler in the Giroux shaft caused the air-current to be reversed and the men were suffocated by the smoke and fumes, their bodies being found soon after hanging to the ladder about 400 feet from the surface.

About two hours after the discovery of the fire, the bodies of Daniel Drae and J. J. McNulty still being in the mine, both shafts were closed and tightly sealed. Before closing, however, a 2-inch pipe was lowered a distance of 500 feet down the Giroux shaft and through this pipe, and independently down the Alpha shaft, live steam was forced into the workings. The supply at the mine being limited, water was hauled to the mine in railroad tank cars and after being mixed with salt, was run into the main shaft.

Edward Ryan, mine inspector for the state of Nevada, reached Kimberly on the evening of the 25th of August with rescue apparatus and upon his arrival telegraphed for the writer, who reached the mine with additional oxygen apparatus 24 hours later.

On the morning of the 27th one compartment of the shaft was uncovered for a few minutes to permit the hoisting of one of the cages, but as considerable smoke and fumes were detected, it was immediately resealed. Equipment was then prepared for the purpose of descending the shaft as soon as it could be opened. Skeleton shoes, Fig. 1, about 20 feet long were attached to the upper part of the cage upon which had been built a solid wooden fence 4 feet high that it might be impossible for any of the rescue party to fall off in event of his being overcome by gas. An iron sinking bucket was suspended by a heavy chain about 10 feet below the bottom of the cage. A large cluster of electric lights was placed on the bucket in addition to hand lamps, and the cage was provided with single lamps. These lights were all connected by means of a single coupling to a feed-wire which was lowered down the shaft with the cage. When the cage was hoisted the coupling was disconnected and the feed-wire allowed to remain suspended in the shaft. A bell cord was also carried from the surface and it and the light feed were held in place by staples driven into the timbers about 25 feet apart.

The opening of the shaft was delayed somewhat by lack of water, but on the morning of the 31st, the storage tanks and reservoirs being full, it was finally unsealed. A small stream of water was allowed to run down the compartment the exploring party were to use, that the smoke and steam might be forced from it into the largest compartment, from which it was separated by a thin lining. Before descending the shaft the old hemp bell rope was pulled up and it was found that all but 500 feet had been burned.

It was decided safer to use two cages in the work; the regular one in the main way and that in

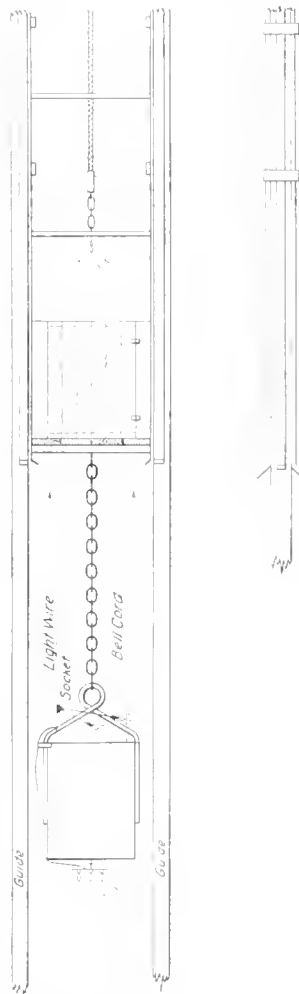

FIG. 1. ARRANGEMENT OF GUIDES AND CAGE

* Mining Engineer, Trinidad, Colo.

the pipe way. The party consisted of four men equipped with oxygen helmets, two of whom were in the hanging bucket, one in the cage immediately above and the fourth in the second cage in the pipeway. The two men in the bucket, by means of the lights suspended below it, were easily able to inspect the condition of the shaft, as the cage was at no time lowered more than 6 feet on one signal. The man on the cage attended to the lowering of the feed-wire and bell cords and also gave all the signals.

Immediately upon clearing the shaft the body of Drae was found, as stated before, on the first ladder landing and but 15 feet from the surface. On this, the first day, it was impossible to descend over 500 feet and but little damage to the shaft was found to this depth. Owing to the limited water supply prohibiting a second shift, the shaft was sealed for the night. Similar work was carried on during the three following days, September 1, 2, and 3, but as the quality of the air continued to improve, the men in the bucket discarded their helmets to better carry on the work of retimbering, although the man in the cage continued to wear the apparatus so that if any gas was encountered one of the party might be in a position to see to it that all were safely brought to the surface.

The first indications of the fire were encountered at about 600 feet from the surface where the lagging was slightly scorched. From this point down to the 1,000-foot level conditions constantly grew worse, although the fact that the door at the first, or 770 foot, station had been closed prevented any damage at all being done to the level itself. At 950 feet from the surface the lagging was almost entirely burned out, the guides were nearly destroyed, and in some places there were bad caves owing to the destruction of the blocking of the wall plates.

On the morning of September 4 it was decided to make an attempt to reach the 1,000-foot level in the hope of recovering the body of McNulty. The recovery party consisting of Messrs. Ryan, McGuinn, and Sanderson, wearing helmets, were slowly lowered to this level. The shaft and station were found to be in very bad condition and the latter seemed still to be on fire. It being impossible to enter the station or to descend lower in the shaft, the party was hoisted to the surface and preparations made to again seal the workings. A pipe was again lowered, but this time to the level of the 1,000-foot station, and after sealing, live steam was turned into the workings as before.

Upon finally opening the two shafts after a period of about two weeks the fire was found to be completely out and the work of retimbering was begun. When this work was finished it was found that the most damage had been done in the vicinity of the 1,000-foot level. The water was found to have risen in the shaft to within 30 feet of this station, but at the surface of the water the timbers were but slightly scorched, indicating that the fire had started at the 1,000-foot level, either in the station or in the station pocket.

The following men comprised the shift in the mine on the night of the fire: Timothy Gilmore, shift boss, John Wilhelm, Thomas Odalovich, Edward Walsh, M. E. Foley, Daniel Drae, and J. J. McNulty, who lost their lives, and Clarence Gates, Peter Harrington, and Edward Knox, who, while badly burned, still survive.

采 采

Cooperative Drainage

Drainage through the Roosevelt tunnel is adding 740 feet to the workable depth of the mines in the Cripple Creek district; and the estimated gross value of the ore in the new ground thus made available for profitable mining exceeds \$200,000,000. The flow of water from the tunnel has been increased by the work done in the last few months, and is now about 8,500 gallons per minute. This is lowering the water level throughout the district at the rate of 4½ inches daily. Tunnel drainage by taking advantage of the topography of the camp is accomplishing for less than \$600,000 a work that would have required \$10,000,000

to accomplish by pumping. The success of the undertaking is the result of voluntary cooperation.

In the Leadville district the large outlay of capital that would be involved in the construction of a drainage tunnel makes it necessary to depend on pumping to keep the deeper workings dry. Cooperation, however, is just as economical in pumping as it is in the construction of tunnels, and there has recently been organized at Leadville a cooperative company for unwatering the deep levels of the mines on Carbonate and Fryer hills. Power for operating the pumps will be furnished by the Central Colorado Power Co., which is taking an active interest in the enterprise. In Clear Creek and Gilpin counties, the Argo or Newhouse, the Central, and other long adits have provided cheap drainage for mines where the expense of pumping for years made ore production unprofitable. These tunnels are private enterprises, and for a return on the capital invested they depend on contracts made with the mine owners and operators.

The unwatering of the old mines at Aspen through the Free Coinage shaft has also been a private enterprise. In other mining districts there are opportunities for making comparatively small expenditures in drainage yield large returns in the opening of new and productive ground.

Under the provisions of an act passed by the last legislature, cooperation may be made compulsory in drainage enterprises. The act permits the organization of drainage districts with functions corresponding to those of municipal improvement districts with power to issue bonds and levy assessments on property benefited by the tunnels and other means.

采 采

Cobalt, Ontario, Silver Shipments, 1911

According to the Cobalt *Nugget*, there was shipped from the Cobalt, Ontario, silver district, 24,831 tons of ore containing 32,000,000 ounces of silver in 1911. This was a reduction in tonnage compared with 1910, which was about 32,800,000 tons, but this is accounted for by a number of mines having their ore concentrated previous to shipment. The approximate value of the ore is given as \$17,000,000, which is an increase over that in 1910.

Total shipments made by the 31 producing mines for the years 1910 and 1911 are as follows:

Mine	1910	1911
Badger		27.10
Bailey		20.00
Beaver	140.06	790.81
Buffalo	1,183.77	1,063.11
Casey-Cobalt	48.40	150.84
Chambers-Ferland	885.92	622.85
City of Cobalt	329.40	281.30
Cobalt Central	283.62	22.40
Cobalt Lake	296.80	2,111.46
Cobalt Townsite	310.99	720.21
Colonial	178.60	114.10
Coniagas	1,268.28	1,824.28
Crown Reserve	2,814.25	977.33
Drummond	2,194.41	706.99
Green Meehan		101.90
Hargraves	343.68	102.44
Hudson Bay	260.33	909.05
Kerr Lake	5,088.78	1,292.58
King Edward	134.12	20.00
La Rose	5,131.53	3,581.54
McKinley-Darragh	2,393.39	2,655.20
Nancy Helen		
Nipissing	6,833.81	2,952.20
Nova Scotia		
North Cobalt		3.73
O'Brien	608.57	683.53
Peterson Lake		
Little Nip	313.76	28.45
Nova Scotia		
Provincial	52.05	100.54
Right of Way	981.41	664.98
Rochester	28.30	
Silver Bar		3.00
Silver Cliff	156.84	92.30
Silver Leaf		
Silver Queen		
Femisgaming	1,119.12	855.60
Trethewey	536.64	630.46
Waldman	31.99	
Wyandoh	24.15	
	33,976.97	24,831.32

Sixteen Tons of High Explosive in a Blast

By Frank C. Perkins

The accompanying illustrations show the results of the use of dynamite and Judson powder to the extent of 33,250 pounds, exploded at one time at the western end of Roseville Mountain, near Netcong, N. J., by which 23,000 cubic yards of rock were broken. This remarkable blast was made in the construction of the Lackawanna cut-off.

Fig. 1 shows the east side of the mountain before the blast; Fig. 2 shows the blast at the moment the high explosives were set off at Roseville Mountain; and Fig. 3 shows the broken rock and the condition of the east side of Roseville Mountain after the blast had taken place.

It is of interest to note that the first explosive placed in the tunnel constructed for the blast consisted of 1,700 bags of Judson railroad powder, each 12½ pounds in weight. When all these were put in the 65-foot arm of the rear transverse section, the pile was higher than the knees of the workers. This powder, manufactured at the Kenvil works of the Du Pont de Nemours Powder Co., because of the presence of 5 per cent. of nitroglycerine, can be classed as a high explosive, but is neither dynamite nor black powder. It consists of ground coal mixed with nitrate of soda and sulphur. The grains of this composition do not absorb the nitroglycerine, but furnish a surface for it. The reddish brown smoke that was seen after the blast was caused by the nitrous gases given off by this explosive. Judson powder acts more rapidly than black powder and slower than dynamite. It is held that whereas dynamite has a powerful shattering effect, Judson railroad powder exerts more of a lifting force. These different characteristics were easily seen following the explosion. Contractor Waltz, although greatly pleased over the success of the explosion, regretted that 60-per-cent. straight dynamite had not been used in this particular part of the tunnel as in the rest, for the rock would have been broken to a greater extent and could have been more easily removed.

The 240 cases of "straight" dynamite, weighing 50 pounds, which were placed in the five other compartments of the tunnel, were 60-per-cent. "Red Cross," a kind of dynamite made at Lake

Hopatcong, so as to have the low freezing point of 35° F. It was found that there was no danger of this mixture of nitroglycerine, wood pulp, and nitrate of soda freezing, for the average temperature of the tunnel was 60° F.

After the explosion it was found that nine-tenths of the rock was broken into such sizes as to be easily handled by a steam shovel. The immense boulders, which were left, some of them weighing 100 tons or more, were later broken by minor dynamite blasts. The residents of Netcong and Stanhope, 5 miles away, had heard so much about the explosion that they expected nothing to be left of their belongings.

Pictures had been knocked off the wall by the Communipaw explosion, and so they were taking no chances with 17 tons of explosives in their back yard. It is stated that in Stanhope and Netcong some people had even gone so far as to take the pictures off the walls, pack the dishes away in trunks, and open the windows, and it is said that students in far away Princeton were sitting around the seismograph with watches trembling in their hands. Princeton was going to record tremors of the earth, which it turned out that most of the spectators did not notice. An explosive expert present, whose system is a sort of seismograph apparatus, since he has experienced so many explosions, said that the tremor felt by him about 500 feet away from the tunnel was surprisingly small. It is

stated that before the 1,500-foot fill across Lubber Run Valley to Roseville Mountain had been entirely completed several men began the work of tunneling, but only two could conveniently work in a space 5 feet high and 4 feet wide. After the tunnel had been driven 73 feet in from the face of the cliff two transverse sections were made. The one at the rear end was 90 feet long, running 25 feet to the north and 65 feet to the south. The other transverse section was 28 feet from the opening. Its length was 12 feet to the north and 15 feet to the south. Between these two transverse sections, near the 90-foot one, the road bed was made and the rails laid. Such an arrangement as this with a combination of dynamite and "Judson railroad powder" had never been tried before in making a railroad cut.



FIG. 2. DURING THE BLAST



FIG. 1. BEFORE THE BLAST



FIG. 3. AFTER THE BLAST

Minerals Common to Silver Deposits

Similarity in Mineralogical Formation of Veins in Various Silver Districts of the World

By W. G. Malletson, E. M.

The discussion of areal geology and vein formation has disclosed their marked similarity in the various silver districts. Since such similarities indicate that the regions were subjected to like chemical and physical conditions at the time of their formation and ore deposition, an investigation along mineralogical lines should reveal many common points of interest.

The Comstock Lode, Nev., consists mainly of a metalliferous, quartz gangue containing disseminated particles of argentite. The vein matter contains clay, quartz, argentiferous minerals, and country rock varying in size from a grain of sand to horses thousands of feet in length. The principal silver ores are argentite, stephanite, native silver, and galena. The rich products are found on the hanging wall side in close association with the earlier diabase, the tenor falling off rapidly as the west wall of diorite is approached. Fragments of country rock, enclosed in the vein, serve as crystallization centers. The gangue of the lode is essentially quartz although calcite is found in certain areas.

At Tonopah, Nev., the ores are in quartz veins, the quartz, as in the case of the Comstock, constituting almost the entire vein with particles of silver minerals disseminated so finely as to be barely visible to the naked eye. The primary ores have a

gangue of quartz, adularia, some sericite and carbonates, and contain besides argentite, polybasite, stephanite, silver selenide, gold, chalcocopyrite, pyrite, some galena, and sphalerite. Near the surface, the ore is not a truly oxidized one but an intimate mixture of original sulphides and selenides together with secondary sulphides, chlorides, and oxides. Secondary sulphides include argentite and pyrargyrite.

Pyrargyrite is abundant; combinations of silver with chlorine, bromine, and iodine as embolite and iodyrite are also found. The principal metallic mineral is a black sulphide of argentite and polybasite. The important veins all occur in the earlier andesite.

The silver veins of Pachuca, Mex., like those of the Comstock and Tonopah, consist of a gangue of white quartz carrying silver minerals. There are two zones, the upper composed of oxides and the lower of black sulphides. The upper zone contains, as principal minerals, outside of auriferous iron, oxides of manganese, and chlorides and bromides of silver. The lower zone contains sulphides of silver, lead, etc.

Calcite is found only in small quantities in the gangue. Pyrite, galena, and argentite have often been deposited at the same time as the quartz and are so perfectly blended with the latter that physical separation is impracticable. The quartz, as in the case of the Comstock, has been deposited alone in places, the barren portions alternating with the rich sections.

The horses present are covered with quartz and sulphides.

Manganese, as the oxide and carbonate, is so abundant in the veins that it sometimes constitutes a large part of the matrix. Pyrite is frequent in the mineralized portions of the veins and in the immediate vicinity, where it has often served to indicate the proximity of deposits. Pyrite, occurring in crystals, is barren; the granular pyrite of the veins, on the other hand, is always associated with fine-grained galena, argentite, chalcocopyrite, and sometimes stephanite and polybasite. Native silver is found at all depths. Generally where there is rhodonite the ore is rich in its silver content.

At Guanajuato, Mex., the ores are designated as white and black. The white ores, as in the three previous instances, consist largely of a white quartz gangue with fine disseminated particles of argentite. Calcite as a gangue associate, and the silver minerals, stephanite, polybasite, and miargyrite, are also present. Copper, lead, and zinc minerals are observed. Proustite, cerargyrite, and embolite may be found in the upper workings. The black ores contain argentite and pyrite chiefly.

The vein filling at Cobalt, Ont., consists of native silver in masses, films, flakes, sheets and wire-like forms associated with calcite as a gangue material. Quartz is also present as a gangue, but not to any great extent. Dyscrasite, found at the Consols mine, Broken Hill, Australia, in abundance, also occurs at Cobalt,

associated with silver. Silver also occurs intimately mixed with arsenides of cobalt and nickel. Most of the veins are found in the lower Huronian, some in the diabase and some in the Keewatin. The intimate association of the veins with the diabase finds a close analogy in the mineral occurrences at the Comstock Lode.

The chief silver minerals

found at Aspen, Colo., are a fine-grained, argentiferous steel galena, varying in value from a few to several thousand ounces of silver per ton; exceedingly rich polybasite, silver glance, and cerargyrite or chloride of silver, the latter not infrequently adhering to calcite crystals lining open cavities in the limestone. Gangues, which accompany these minerals, consist chiefly of quartz in small crystals or crystalline aggregates, crystallized ferrous dolomite, barite, and calcite.

Near the surface, the ores of the Aspen district occur as oxides, sulphates, and carbonates, mixed with the sulphides from which they were derived. These oxides and sulphates disappear with depth giving way to the sulphides. By a process of reduction, much native silver has been formed. Local dolomitization and extensive silicification have invariably accompanied ore deposition. The chief ore deposits occur in limestone or dolomite and, as at Pachuca and the Comstock, the ore bodies increase in size with depth.

The ores at Park City, Utah, consist essentially of argentiferous lead sulphides with accessory gold, copper, and a silicious gangue. The values in the sulphide zone are found in the galena, tetrahedrite, and pyrite; in the oxidized zone they occur in the cerussite, anglesite, azurite, malachite, and complex oxidation products. Silver is found in the native state; zinc is a common associate in fissure ore and appears to increase in depth. Barite and fluorite occur sparingly.

The Leadville, Colo., minerals which carry the main values in silver are an argentiferous galena, cerussite, cerargyrite, and a basic



DALY-WEST MINE AND MILL, PARK CITY, COLO.

Table Showing the Distribution of the Most Important Minerals of the World's Greatest Silver Districts

Mineral	Chemical Composition	Comstock	Tonopah	Pachuca	Guana-juato	Aspen	Leadville	Park City	Coeur d'Alene	Cobalt	Broken Hill
Argentite.....	Ag ₂ S	+	+	+	+	+					
Stephanite.....	Ag ₂ Sb ₂ S ₄	+	+	+	+		+	+			+
Polybasite.....	(Ag, Cu) ₂ Sb ₂ S ₄		+	+	+	+					
Cerargyrite.....	AgCl		+	+	+						
Proustite.....	Ag ₂ As ₂ S ₃	+			+				+		
Pyrrargyrite.....	Ag ₂ Sb ₂ S ₃	+			+	+				+	
Ag Selenide.....	AgSe		+								
Native Silver.....	Ag	+			+	+	+	+			+
Dyscrasite.....	Ag ₂ Sb, Ag ₂ Sb			+	+	+		+		+	+
Miargyrite.....	Ag ₂ S ⁺ Sb ₂ S ₃				+					+	
Iodyrite.....	AgI		+	+							+
Embolite.....	Ag(Cl, Br)		+	+			+				+
Stromeyerite.....	(Ag, Cu) ₂ S			+	+						+
Silver-Antimony Cl.....	Sb-AgCl										+
Fahlerz ¹	4(Cu, Fe, Zn, Hg, Ag) + (Sb, As, Bi) ₂ S ₂										+
Panabase ¹	4(Cu, Fe, Zn, Hg, Ag) + (Sb, As, Bi) ₂ S ₂										+
Freieslebenite.....	5(Pb, Ag) ₂ S + 2Sb ₂ S ₃				+						+
Bromyrite.....	AgBr				+						+
Naumannite.....	(AgPb)Se				+						+
Galena.....	PbS	+	+	+	+	+	+	+			+
Anglesite.....	PbSO ₄				+	+	+	+			+
Cerussite.....	PbCO ₃				+	+	+	+			+
Pyromorphite.....	(PbCl)Pb ₃ P ₂ O ₁₁				+	+	+	+			+
Minium.....	Pb ₃ O ₄					+	+	+			+
Litharge.....	PbO					+	+	+			+
Massicot.....	PbO						+	+			+
Plattnerite.....	PbO ₂							+			+
Wulfenite.....	PbMoO ₄						+	+			+
Dechenite.....	PbV ₂ O ₅						+	+			+
Tetrahedrite.....	Cu ₁₂ Sb ₂ S ₇			+		+		+	+		+
Tennantite.....	Cu ₁₂ As ₂ S ₇			+		+		+	+		+
Chalcopyrite.....	CuFeS ₂		+	+	+	+	+	+			+
Bornite.....	Cu ₅ FeS ₄				+	+	+	+			+
Azurite.....	2CuCO ₃ ·CuO·H ₂ O				+	+	+	+			+
Malachite.....	CuCO ₃ ·CuO·H ₂ O				+	+	+	+			+
Melaconite.....	CuO					+	+	+			+
Cuprite.....	Cu ₂ O					+	+	+			+
Chalcocite.....	Cu ₂ S					+	+	+			+
Covellite.....	CuS						+	+			+
Native Cu.....	Cu						+	+			+
Chrysocolla.....	CuSiO ₃ ·2H ₂ O				+	+	+	+			+
Pyrite.....	FeS ₂	+	+	+	+	+	+	+			+
Siderite.....	FeCO ₃		+	+	+	+	+	+			+
Pyrrhotite.....	Fe _n S _{n+1}						+	+			+
Magnetite.....	Fe ₃ O ₄						+	+			+
Martite ²	Fe ₂ O ₃						+	+			+
Hematite.....	Fe ₂ O ₃				+	+	+	+			+
Limonite.....	2Fe ₂ O ₃ ·3H ₂ O				+	+	+	+			+
Mispickel.....	FeAsS						+	+	+		+
Sphalerite.....	ZnS	+	+	+	+	+	+	+			+
Smithsonite.....	ZnCO ₃				+	+	+	+			+
Calamine.....	H ₂ Zn ₂ SiO ₃						+	+			+
Rhodochrosite.....	MnCO ₃		+	+	+	+	+	+			+
Rhodonite.....	MnSiO ₃			+	+	+	+	+			+
Wad.....	BogMn					+	+	+			+
Mn Oxides.....					+	+	+	+			+
Pyrolusite.....	MnO ₂				+	+	+	+			+
Bustamite.....	(Mn, CaO)SiO ₃			+			+	+			+
Cobaltite.....	CoAsS									+	+
Smaltite.....	(Co, Ni)As ₂									+	+
Chloanthite.....	(Ni, Co)As ₂									+	+
Erythrite.....	Co ₂ As ₂ O ₈ + 8H ₂ O									+	+
Nickel.....	Ni						+	+			+
Nicolite.....	NiAs									+	+
Millerite.....	NiS									+	+
Annabergite.....	Ni ₂ As ₂ O ₈ + 8H ₂ O									+	+
Native Gold.....	Au	+	+		+		+	+			+
Native Bismuth.....	Bi									+	+
Graphite.....	C									+	+
As Sulphide.....							+	+			+
Antimony Sulphide.....							+	+			+
Bi-Sulphide.....							+	+			+
Tin.....	Sn						+	+			+
Cadmium.....	Cd						+	+			+
Selenium.....	Se		+				+	+			+
Tellurium.....	Te						+	+			+
Stibnite.....	Sb ₂ S ₃								+		+
Scheelite.....	CaWO ₄								+		+
Epsomite.....	MgSO ₄ ·7H ₂ O								+		+
Quartz.....	SiO ₂	+	+	+	+	+	+	+	+	+	+
Adularia ³	KAlSi ₃ O ₈		+	+	+	+	+	+	+	+	+
Sericite.....	Mica		+	+	+	+	+	+	+	+	+
Calcite.....	CaCO ₃	+		+	+	+	+	+	+	+	+
Barite.....	BaSO ₄			+	+	+	+	+	+	+	+
Gypsum.....	CaSO ₄ ·2H ₂ O				+	+	+	+	+	+	+
Aragonite.....	CaCO ₃				+	+	+	+	+	+	+
Dolomite.....	(Ca, Mg)CO ₃				+	+	+	+	+	+	+
Amethyst ⁴	SiO ₂				+	+	+	+	+	+	+
Chalcedony ⁴	SiO ₂				+	+	+	+	+	+	+
Valencianite ³	KAlSi ₃ O ₈				+	+	+	+	+	+	+
Fluorite.....	CaF ₂				+	+	+	+	+	+	+
Barytine.....	BaSO ₄				+	+	+	+	+	+	+
Apophyllite.....	H ₇ KCa ₄ (SiO ₃) ₆ ·4H ₂ O				+	+	+	+	+	+	+
Stilbite.....	H ₄ {CO ₃ / NO ₃ }Al ₂ Si ₆ O ₁₈ ·4H ₂ O	+			+	+	+	+	+	+	+
Anthophyllite.....	(Mg, Fe)SiO ₃				+	+	+	+	+	+	+
Xonolite.....	4Ca ₂ SiO ₃ + H ₂ O			+	+	+	+	+	+	+	+
Chlorite.....	Hydrous Silicate of Al, Fe, Mg						+	+	+	+	+
Silica.....	SiO ₂						+	+	+	+	+
Chabasite.....	(Ca, Na ₂ K ₂)Al ₂ Si ₄ O ₁₂ ·6H ₂ O	+					+	+	+	+	+
Garnet.....	{Ca / Mg / Fe / Mn} {Al / Fe / Cr / Ti} (SiO ₄) ₃							+	+	+	+
Tourmaline.....	{Na / Li} {Mg / Fe} {Al / Cr} B ₂ Si ₆ O ₁₈							+	+	+	+
Biotite.....	{K / H} {Mg / Fe} Al ₂ Si ₃ O ₁₂							+	+	+	+

¹Variety of Tetrahedrite. ²Pseudomorphic. ³Variety of Orthoclase. ⁴Variety of Quartz.

sulphate. The gangue minerals consist of silica, with oxides of iron and manganese. In the oxidized zone, the predominant mineral is cerussite, while silver chloride occurs in a matrix of impure iron and manganese oxide, resulting from the oxidation of pyrite. Native silver, unaltered galena, smithsonite with vugs of calamine are also found. Generally in the oxidized ores, the silver content diminishes with depth.

The unoxidized zone contains large quantities of galena and pyrite carrying silver. Sphalerite is also somewhat common. Rhodonite and rhodochrosite are entirely absent from the sulphide ore bodies.

Argentiferous galena, intimately associated with siderite, constitutes the main ore of the Cœur d'Alene, Idaho, region. The minerals found in the oxidized zone are cerussite, cerargyrite, native silver, pyromorphite, malachite, azurite, and limonite. The sulphide zone consists of argentiferous galena with pyrite, pyrrotite, chalcocopyrite, sphalerite, and rarely stibnite or chalcostibite as associates. The most common gangue mineral is siderite, although quartz is by no means uncommon. Other gangue minerals, somewhat less common, are barite, calcite, garnet, and chlorite. Tetrahedrite, occurring in bunches, is an important silver-bearing mineral. Pyrite

The ores at the Broken Hill Consols mine, in New South Wales, are almost exclusively silver ores, the bulk of the metal being present as stromeyerite and other permanent silver sulphides. To a vertical depth of 130 feet, the lode gangue is limonite, and below this, siderite and calcite. Dyscrasite is a frequently occurring mineral, having been found in quantities ranging from small crystals to huge blocks weighing over a ton.

The ore bodies at the Consols mine are constantly associated with cobalt minerals. The two seem to be inseparable, neither being found without the other. The cobalt is in the form of cobaltite and as a rule does not occur in immediate contact with the silver ore, but in a separate vein of lode material above or below the silver.

Mineralogical Comparisons.—An excellent idea of the marked similarity in mineralogical conditions existing between the various silver districts is given by the accompanying table. It will be seen that, with perhaps one exception, the important silver mineral is argentite, existing as such in a quartz gangue or intimately associated with steel galena. All the districts, except Cobalt, contain galena, pyrite, and sphalerite, either as ores or important associates. Quartz is found in all camps but Leadville, and is the important gangue constituent in the majority of cases. Calcite is present in every district, usually associated with quartz. Where quartz is subordinate, calcite generally becomes the important gangue constituent, except in the case of the Cœur d'Alene district.

The marked similarity in minerals of those districts where volcanic activity has been widespread is worthy of especial note. These regions are practically identical in their vein filling (a massive quartz gangue with finely disseminated particles of argentite and other silver minerals), in their kind of silver ores (stephanite, polybasite, and cerargyrite being found in all districts except the Comstock, where stephanite only is important), and in their oxidized zones.

The sedimentary districts of Aspen, Leadville, Park City, Cœur d'Alene, and Broken Hill* are also similar in their kinds of important ores and in their oxidized and unoxidized zones. Other minor points of similarity between two or more of the districts mentioned will be noticed when studying the table.

來 來

The Modern "Flint and Steel"

These "flints and steels," like those of our forefathers, produce sparks by the blow of a piece of steel on a special stone. But this stone is not the old flint of long ago, and the sparks are so hot that at the first blow they will kindle tinder or a match soaked in benzine or alcohol. This discovery is due to Auer, who found the necessary qualities in an alloy of iron and cerium. It has been known for some time that other metals than iron would give pyrophoric sparks when struck. M. Chesneau, in 1896, showed that uranium gave sparks that would kindle a mixture of inflammable gases. The pyrophoric qualities of the cerium family of metals have long been known. But alone they are too soft and light, and Auer conceived the idea of alloying them with iron.—*La Nature*.

*According to Stokes, doubt still seems to exist as to whether the Broken Hill region is of sedimentary or volcanic origin.



LEADVILLE, SHOWING SAWATCH RANGE IN DISTANCE, FROM YORK MILL

is usually associated with the quartz. In general, the low-grade ore is quartzose and pyritic, while the rich product consists chiefly of galena and siderite. The ores show a decrease in tenor with depth.

Broken Hill Proprietary mines in New South Wales have ore composed of an intimate mixture of galena and zinc blende with silver in combination as argentite. Generally speaking, the mines at the northern and southern ends of the field have a quartz-calcite gangue, while those more centrally situated have a gangue of garnet sandstone and rhodonite.

The surface at Broken Hill consists of a massive black outcrop of magnetic ironstone. Underneath this cap occurred the oxidized ores known as the carbonate dry, high and low grade. The carbonate ores always contained cerussite with a considerable portion of silicate of aluminum and oxides of iron and manganese; the dry, high-grade ore consisted of kaolin containing garnet and quartz carrying native silver, cerargyrite, embolite, and iodyrite running up to 300 ounces of silver per ton.

Below the oxidized zone are found the friable sulphides, consisting of somewhat loose aggregates of galena, blende, and a gangue of silica and garnet. Beneath the friable sulphides are the compact sulphides, composed of an intimately mixed mass of galena and blende with a gangue of quartz, rhodonite, and garnet.

Queensland Miners' Health Commission

Conditions in Regard to Temperature and Dust From Ores and Methods for Overcoming Them

In February, 1911, a Royal Commission was appointed to inquire into and report upon the health conditions in the Queensland mines. The Commission reported on June 30, 1911, and the following abstract from their report is taken from the *Queensland Government Mining Journal*. Three conditions were required of the Commission and are given in their order.

First: The Conditions of Work in Relation to the Health of the Miners.—These, underground, are dust and fumes, temperature and humidity, drinking water supply, sanitary conveniences, and change houses. The dust underground in ore mines is produced by rock drilling, by operations connected with shoveling broken ore and rock, tramping, filling stopes, tipping ore and rock in the chutes and drawing it therefrom, and by the use of explosives. The latter is the chief agent in the production of fumes. Rock drilling, owing to the nature of the dust produced is generally regarded as the most serious from the health point of view. Although dust is produced in hand

drilling the amount in suspension in the air, and thus liable to be inhaled, is inconsiderable in comparison with that made with machine drills. The production and danger of inhalation of dust in the use of machine rock drills are influenced chiefly by the kind of work, method, and appliances used, the type and construction of the drill being definite factors. No dust is given off from holes where water can be used, but where it is necessary to bore at such an angle that water cannot be used without special appliances, the sharp dust is discharged from the hole. Dry holes are avoided in some of the operations, but the majority of the work requiring rock drills necessitates the boring of dry holes from which the dust is produced. The most acute conditions are in rises where the men become rapidly covered with dust. A machine leaking from the front head, or where the exhaust blows too much to the front, aggravates the dust trouble from machines.

Dust and fumes from the use of explosives are especially troublesome in confined places where the ventilation is not regular, and may be troublesome in other places where firing is done during shifts, in which case they may be carried in the air to men working in other parts of the mine. The trouble from dust in this connection arises not only from actual work in hand, but in certain parts of the mines dust raised by various operations settles on the timber and elsewhere, and when heavy firing takes place it rises and remains in the air. In certain work, such as drives, where after the first holes are fired the miners proceed as soon as possible to take out the remainder of the face, the extreme conditions are met while charging the next round of holes.

In regard to the dust from explosives, from shoveling, tramping, and other causes, conditions in various cases have an important bearing on dust prevention, as in a number of cases moist or wet conditions prevail in the mines rather than dry. The kind of rock in the mines is of importance as a factor in the nature and hardness

of the dust; with but few exceptions the harmful effects traceable to dust are found to rise from its action as a mechanical irritant and not from any chemical action exercised by it in the body. As regards actual poisonous dust, trouble is caused by the dust from lead ore in the form of carbonate.

Views were advanced as to the particular nature of the rock and dust in various mines by a number of witnesses, particularly at Croydon, in regard to the so-called plumbago, and on this account samples were obtained from a number of mines, dust also being collected on dishes coated with vaseline, by exposure in different atmospheres with a view of obtaining a comparative idea of the amount of dust present.

The principal factors which were found to affect temperature and humidity underground are the depth of the mines, geographical position, and the quantity of fresh air furnished the workings. A large number of observations underground of wet-bulb and dry-bulb temperatures were taken.

In the metalliferous mines high temperatures are met with under more or less special circumstances in nearly all cases, but at a greater depth special circumstances render excessive conditions very frequent. A factor of great importance in some of the workings of moderate depth is the heat evolved in the oxidation of the ores, and instances of this occur in some of the larger deposits, particularly at Mungana and Mount Elliott. An instance at the latter mine was brought prominently under the notice of the Commission, where a record of 101° F. with complete saturation was obtained in a portion of a stope close by where men were endeavoring to work.

The circumstances under which high temperatures are most generally recorded in the mines are in rises, ends, and places difficult to ventilate, but in the very deep mines where records were taken at 2,800 feet, conditions under which it is not possible to do continuous work tend to become the common rule. That this is the case, abundant proof was furnished to the Commission in seeing the men continually coming out and cooling off at the plats as the mines were visited, and also by the evidence given by practically all the witnesses at Charters Towers. The temperature conditions observed in some of the stopes in these mines were often over 90° F. with almost complete saturation.

At the greater depths, heat contributed to the mine air by increasing temperature of the rocks is a most important factor. Mr. Poole gave some evidence on this point, and some observations supplied in the report of the inspector of mines are attached to the report, from which it may be deduced that rock temperatures as high as 109° F. occur in the mines at Charters Towers. This can only be dealt with by increasing the supply of air and it is the inadequacy of the available and usual means of effecting this object that is largely responsible for the excessive conditions existing.

At nearly all the metalliferous mines satisfactory arrangements in the form of bath and change houses are provided and they are kept in fairly good order, although occasionally they are placed rather far from the main exits of the mine. Provision for drying and washing clothes is not always satisfactory, and there are sometimes none at all. It appears from some of the reports



FIG. 1. SPRAYING TO PREVENT DRILL DUST

that where shower baths are provided the men do not make use of them.

In most of the larger and more advanced mines drinking water is supplied for underground use, either by pipes connected with a municipal service, or in tanks or drums taken down from the surface. The mine water, even where fresh, appears to be generally avoided for drinking purposes, and its use is not to be recommended. Where there is no pipe supply, rain water is generally used. At Chillagoe the rain water supplied to the men at the reduction works is boiled before distribution. At Mount Elliott the mine has a special water service laid on to the surface. The men take their own water bags into the mines. A supply of tea is frequently brought by the men when coming on shifts, and in some mines where electricity is available, boxes fitted with electric lights are provided for keeping receptacles warm.

Inquiry was made concerning the effects of mine waters as possible causes of skin diseases. In very few instances was this effect stated by witnesses, although in some mines the water was apparently mineralized. In the few mines where such diseases were stated to occur the men had adopted the use of greasy applications as a preventive with apparently satisfactory results.

At an early stage of the inquiry it became evident that certain conditions connected with work in mines were largely dependent



FIG. 2. SPRAYING DUST AT CHUTE

for their existence upon the voluntary procedure of men themselves. Attention was therefore given to this aspect, both during inspection of the mines and in the course of examination of mining witnesses. A notable feature disclosed was the admitted neglect of miners to apply for spray or jets where they were known to be available on request, and although they themselves strongly advocated their use as a preventive of risk from dusty occupations. The use of respirators in dusty treatment processes was neglected in practice, even where they were available on request and their employment was advocated by the men. Complete appreciation was displayed in respect of the risks from stone dust, but in no instance did any effort appear to be put forth by the men to secure mitigation of these risks, nor was any active assistance afforded the efforts made in the past by various managements to introduce sprays and other dust-preventive measures.

Where drinking water was provided in the mines frequent complaints were made concerning the use of common drinking vessels by men believed to be suffering from disease. The obvious solution afforded by the miners bringing their own vessels is hit upon. Even in the case of private water bags in some of the mines the absence of any practice which was frequently quoted as a source of transmission of disease was very evident.

The spitting habit was noticeably prevalent amongst miners at work, due in part perhaps to the irritation of the throat pro-

duced by dust. Its possible effect of spreading consumption was not appreciated or understood in practice, even where the prevalence of lung diseases amongst miners was most actively appreciated. Some attention was given to the part played by alcohol in connection with the health of miners, and it was found that the free use of alcoholic drinks exercise a well recognized predisposing effect in the production of tubercular pulmonary diseases.

No evidence pointing to the existence of ankylostomiasis was obtained either from direct observation or from medical witnesses. Skin diseases apparently arising from work in mineralized water or mineral dusts were met with in a few instances, but did not appear to be common or widespread.

Second: The Extent to Which the Said Conditions Contribute to Pulmonary Diseases Amongst Miners.—For reasons we conclude that certain forms of pulmonary diseases appear to exercise a special incidence upon metalliferous miners in Queensland, and that this incidence is reasonably ascribed to particular conditions associated with their work. Several of these conditions have been credited with the production of pulmonary diseases amongst miners and are briefly discussed.

Emanations from decaying timber and from the lungs and bodies of men are of somewhat indefinite composition, and their actions have not been thoroughly worked out. Certain volatile substances are present in mines which appear to play a considerable part in producing the feelings of oppression which are so evident in badly ventilated places. It is probable that these agencies have much to do with the production of lowered vitality from the inhalation, for long periods, of air in ill-ventilated occupied places, and that they may therefore serve in some degree as predisposing agencies for the production of certain pulmonary diseases amongst people whose lungs are prepared for the reception of specific infection. It has been found by direct pathological observation that the inhalation for sufficient periods of certain kinds of dust will eventually damage the finer lung tissues, and will lead to the production of fibrous tissue as a result of chronic inflammatory action. This effect is associated in its earlier stages with the destruction of the cilia, whose purpose and action are to sweep particular matter out of the finer air tubes of the lungs. The ultimate result is that the area of lung tissue available for purification of the blood by respiratory interchange and the amounts of air and blood, respectively, which can reach those portions of the lung tissue wherein are carried on the respiratory interchange of gases, are both diminished.

Precise pathological proof concerning the relative activities of various kinds of dust in producing this condition of pulmonary fibrosis has not been encountered by us, and the conditions of inquiry prevented direct experiments.

采 采

Mineral Output of the World

The British Home Office has issued a report in which it is stated that the number of persons employed in the mines and quarries of the world in 1909 was 6,000,000, of whom 1,250,000 were employed in the British Isles and 1,000,000 in other parts of the British Empire.

The world production of coal was 1,113,000,000 metric tons (metric ton=2,204.6 pounds), of which the British Isles produced 268,000,000 tons and the rest of the British Empire 37,000,000, the United States 418,000,000 tons, and the German Empire 217,000,000 tons.

The world output of copper was 800,000 tons; of fine gold, 600,000 kilos (kilo=2.2046 pounds), of which the Transvaal furnished 226,000 kilos; of iron, 58,000,000 tons, of which 26,000,000 tons were in the United States; lead, 1,000,000 tons; petroleum, 40,000,000 tons, of which 24,000,000 tons were American; salt, 17,000,000 tons; fine silver, 6,000,000 kilos, of which 2,250,000 kilos were Mexican; tin, 116,000 tons; and zinc, 855,000 tons.

The total value of the above production is estimated at \$4,209,522,500, the value of the coal output being \$1,946,600,000. The output of gold is said to have had a value of \$455,830,455.

Mining Ore at the Talisman Mine, N. Z.

Geology of the Reef—Methods of Mining and Handling the Ore—Description of the Pumping Machinery

The following is an abstract taken from a paper on mining and ore treatment at the Talisman mine, Karangahake, New Zealand, and presented by Arthur Jamnan to the Australian Institute of Mining Engineers.

The Talisman mine is situated on the Waitawaheta River just above its junction with the Ohinemuri. The explored portion of the property includes the angle formed by the junction of the rivers and extends southwards for slightly over a mile. The triangulation station on Karangahake Mountain is directly above the workings of the Bonanza section and is 1,680 feet above river level, the adit from the gorge giving 1,200 feet of backs measured

it is found that after stoping excellent ore, the grade sometimes decreases until no longer payable, though the change is not accompanied by any change in the macroscopic character of the country rock. Thus the vertical projection, Fig. 1, shows that no stoping has been carried on between levels 6 and 8. Again between levels 11 and 12, and 12 and 13, in the northern portion of the Bonanza shoot, there are horizontal patches which are unprofitable for a vertical depth of about 70 feet in each instance. Changes from good to bad country rock are met when driving levels and cross-cuts.

The Maria reef is the only one of importance at present. It strikes approximately north and south. The outcrop is seen on both sides of the Waitawaheta gorge and the reef has been driven on southwards for over 4,000 feet. It is a fissure vein formed by simple deposition and also by replacement of brecciated material in the fissure. In the upper levels it is almost vertical. The northern half has a slight tendency to dip to the west. A small

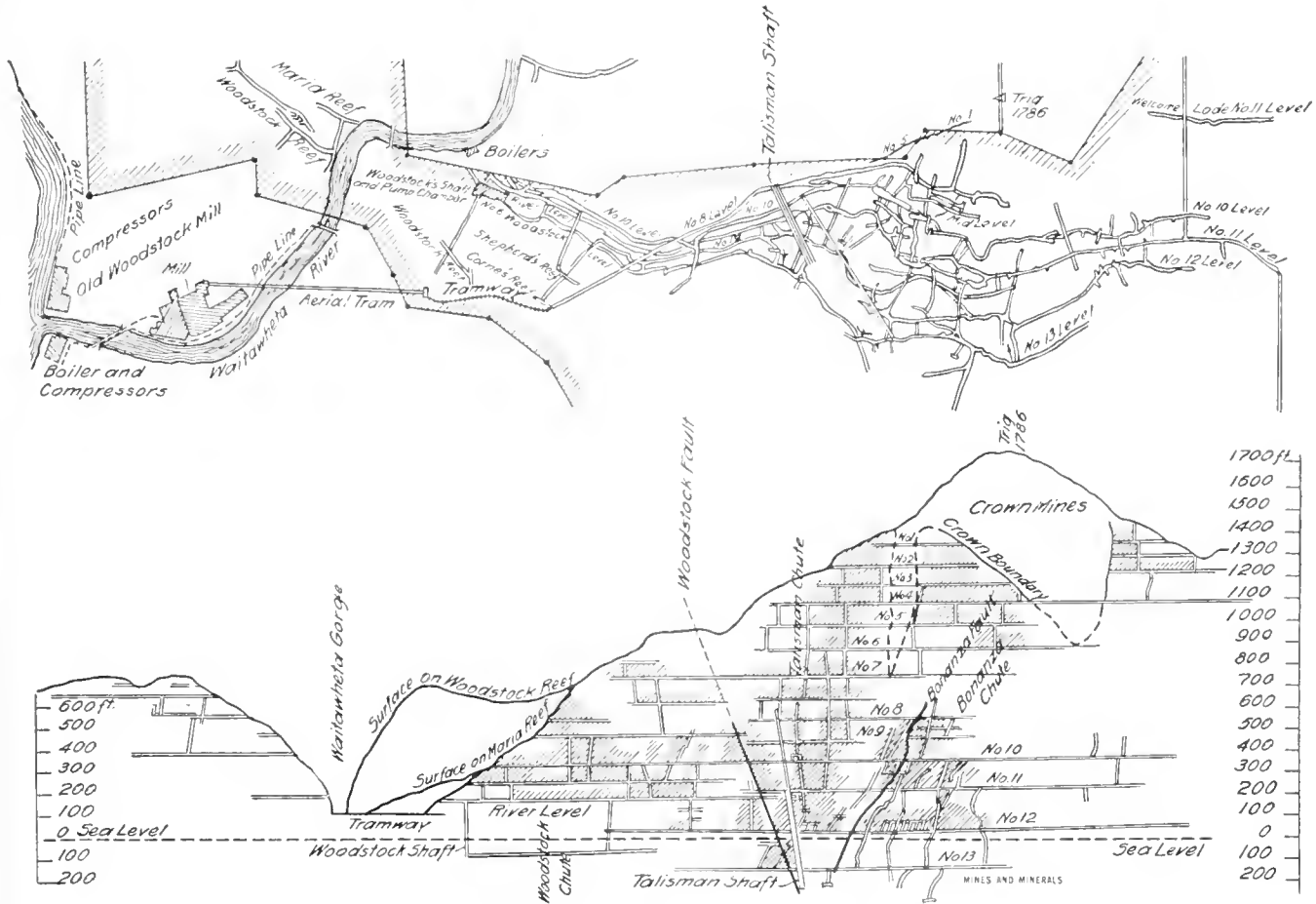

FIG. 1. PLAN AND VERTICAL PROJECTION OF PART OF TALISMAN MINE

vertically. The rocks of the district are andesites and dacites much altered and silicified.

In the zone of oxidation the good country rock is a light bluish-grey compact material which drills well, while in the lower levels it is darker, harder, and a partial alteration of the mass has given it a patchy mottled appearance. Poor country rock may be light bluish-grey and soft enough to clog the holes when drilling by machines, or it may be less decomposed, and hence darker and hard, so that it drills well, but owing to its jointed nature it often breaks in rough slabs when blasted.

The Maria, or the principal reef, does not necessarily carry ore when traversing good country rock, and its patchy nature may be due partly to secondary enrichment having transferred the minerals from barren rocks to the enriched zones below.

In the Bonanza section, the richest portion of the lode, the variations in assay values are more noticeable than elsewhere and

section of the southern portions dipped slightly to the east and crossed the boundary of the Crown mines down to the No. 7 level, as shown by the dotted lines in Fig. 1. Elsewhere in the southern section the dip was always westerly and below No. 6 level it decreased considerably.

There are four pay shoots in the deposit, termed, respectively, Woodstock, Talisman, Bonanza, and Dubbo, which were formerly worked near the surface by separate companies. The width of the vein varies, and where payable ranges from 2 to 12 feet.

In the Woodstock and Talisman shoots the ore has been subjected to oxidation down to the lowest levels of the mine and is not high grade. It is generally white quartz with a faint bluish-grey structure due to sulphides of silver minerals, and as a rule the valuable portion of the vein does not extend across it, but occurs on either wall or in the center.

The Bonanza shoot is the chief ore producer at present. It is

in this section that the change of dip has been so noticeable. Below No. 6 level it flattens until in places it is only 30 degrees from the horizontal. Below No. 12 level the dip again became steep, and this change was accompanied by increased richness of the ore. In most places the vein was good when steep and small and poor when flat. The clay selvage is 3 inches or more thick, generally existing on the hanging wall of the flattened vein. The length of the pay shoot at No. 8 level was only about 20 feet but it lengthened considerably at each succeeding level until at No. 12 it is 600 feet long and at No. 13 over 1,000 feet long, though it should be noted that there are stretches of unprofitable material in these lengths.

The zone of oxidation does not extend below water level, or 1,250 feet vertical from the outcrop. In this zone, which is above the 1,150-foot level, the high-grade ore has evidently possessed the banded structure of the sulphide ore of lower levels, but oxidation has converted much of the sulphides into brown and red oxides of iron, thus giving brown and red streaks alongside the black.

Where masses of sulphides have been converted into hematite the gold is sometimes scattered throughout the mass and has a fineness of about 900.

At No. 10 level the general proportion was 4Ag to 1Au and at No. 11 it had risen to 15Ag to 1Au, although the ore did not carry heavy black sulphide streaks.

At No. 12 level the ore is quartzose with streaks of soft black sulphides of lead and silver running parallel with the walls of the vein, thus giving it a banded structure. Some of the sulphide streaks at No. 12 and 13 levels are 12 inches wide and very rich, so that some of this material was bagged and shipped direct to the smelter.

The bullion carried from 10 to 30 ounces of Ag to 1 ounce of Au. At No. 13 level the sulphide streaks are slightly harder and copper pyrite is more noticeable. Rhodonite, the silicate of manganese, which appeared first at No. 12 level is a true indicator of rich ore in and below No. 13 level.

Where the percentage of copper pyrite is high the ratio of gold to silver dropped to 3 to 1, but in the southern portion of the shoot copper is not so noticeable. The sulphides are more closely grained and the ratio of silver to gold is 8 to 1. At the bottom of the winzes Nos. 6 and 12, the proportion of the copper has increased further and the ratio of silver to gold has fallen 1 to 1. The variability of the gold-silver ratio and the existence of barren or poor patches in this rich Bonanza shoot are both notable features.

At Nos. 5 and 6 levels above the upmost bank there are considerable deposits of friable quartz with black oxide of manganese; and below, there is the rich sulphide zone, strongest at No. 12 level; and again below this is the rhodonite zone at No. 13 level. These zones, arranged as described, suggest very forcibly that secondary enrichment has taken place. In this connection it should be noted that there have been no alluvial workings in this district.

The Dubbo shoot gave a small run of good ore on No. 10 level, but the ore was poor on each of the succeeding levels. At No. 11 level there is about 200 feet of friable quartz with manganese oxides which is unprofitable, and in view of the experience on the Bonanza shoot it will be interesting to watch developments on this shoot at greater depths.

A branch vein diverges from the Maria in the Talisman section at various places above No. 9 level, on the foot-wall side in the upper levels, and on the hanging wall side at Nos. 8 and 9. Below the latter it pinched out, but a considerable tonnage of ore was obtained from this branch. An east branch vein about 3 feet wide commences above No. 11 in the Bonanza section. At No. 11 level it runs alongside the main reef for 500 feet at a distance of 10 to 50 feet but joins with it at both ends. The values here are good. On No. 12 level it diverges up to 200 from the parent vein for a length of 500 feet, but here the ore is not so rich as on No. 11, and does not extend the full length of the branch. At No. 13 this branch vein has been followed for 250 feet and only carries ore for a very short distance which has been winzed on for 80 feet. A

hanging wall branch vein has been cut by a cross-cut on No. 13 level and driven on for 200 feet in which two small sections were payable.

In the Woodstock section there is the Woodstock vein which runs parallel with the main vein at a distance of about 550 feet. It is 4 to 5 feet wide and was only payable near the outcrop. Between these veins are two smaller ones termed Shepherd and Cornes veins, both of which have been cross-cut in No. 8 from No. 12 level. Cornes vein was of low grade but Shepherd was high grade near the outcrop and continued for a depth of 550 feet. These veins, which have been worked on the north side of the Waitawaheta River on Taukani Hill, are probably a continuation of Shepherd and Maria veins. The workings extend nearly to the river level, and when the Woodstock shaft has been sunk 400 feet below the river a level will be extended under the river to explore these veins at that depth. The summer flow of the river is 21.3 cubic feet per second. In the Crown mine, which adjoins the Talisman on the eastern boundary, the main vein is the Welcome. At river level it runs approximately parallel to the Maria about 1,000 feet from it as shown in Fig. 1. It has been intersected in the Dubbo section of the Talisman mine by a cross-cut from the 11th level, and so 350 feet of drifting was done on it without meeting ore. This vein dips west toward the Talisman boundary.

The Maria vein is intersected by several faults which run east and west and give a displacement of from 5 to 15 feet. Two of these, the Woodstock and Bonanza faults, pass through the pay shoots, and consequently have been followed with interest. The Woodstock fault dips south at about 60 degrees from the horizontal and keeps a very steady course through the Talisman shoot. Between the 10th and 11th levels good ore exists on the south sides but between the 11th and 12th levels there was good ore on both sides, that on the north being of lower grade than that on the south. Between levels 12 and 13 it passes through the stopes, and 80 feet below level 13 it cuts the inclined shaft and the water coming from it was too much for the pumps.

The fault material is clay and oxides and the stopes on either side contain a considerable quantity of this material as horses or fault walls. The Bonanza fault dips to the north, the amount of the dip varying as shown in the section, Fig. 1. Above level No. 10 it is in the center of the Bonanza shoot but between levels 11 and 13 it runs approximately on the northern boundary, but below level 13 in No. 6 winze high-grade ore occurs on its northern side.

It is interesting to note that what is probably the same fault passes through the principal pay shoot of the Welcome reef in the Crown mines, these shoots being opposite to one another on parallel lines. Down on the 8th level access to the workings in the Talisman, Bonanza, and Dubbo sections was obtained by adits only. From this level an inclined shaft was sunk, dipping west 62 degrees from the horizontal and also pitching slightly south. This was put down by the old Talisman company. To the 11th level it is divided into three compartments, a ladderway and two skipways. Below the 11th level a fourth compartment is added, the dimensions of the shaft being over all 18 ft. \times 6 ft. and containing skipways together occupying 7 ft. \times 4 ft., one rock skipway 3 ft. 6 in. \times 4 ft., and one compartment 4 ft. 10 in. \times 4 ft. for the ladderway and pump pipes. At present ore is hoisted by air winzes up to the top of this incline shaft in No. 8 level, from which it is hauled by horses to the top station of an aerial tramway connected with the mill.

In the Woodstock mine access was obtained by adits driven in the vein and the deposit from the precipitous edge of the Waitawaheta ravine. The river level, which is about 30 feet above the ordinary water level, now provides a chief entrance to the Talisman mine. The tramway at the mouth of this level is cut out of the rock in many places. After driving this level 100 feet, a station was cut in which a head-gear was erected and a shaft then sunk vertically for 240 feet. This Woodstock shaft has three compartments, a pump and ladderway compartment 6 ft. 6 in. \times 6 ft., and two hoisting compartments, each 4 ft. \times 6 ft. inside the timbers. Sinking is to be continued for another 200 feet, and a straight haulage level will then be driven to connect with

No. 14 level, which will be the next one to be opened on the Talisman and Bonanza shoots.

Ore is now being obtained on the Woodstock shoots in No. 12 level, and should this be found to continue downwards the haulage level will be driven on the course of the vein. Electric haulage will be used. This shaft will be the pumping shaft and will be sunk in advance of other development workings, so there should be no further trouble occasioned by water.

To accommodate the pump engine, winding engine, and pump winch, the existing chamber had to be considerably enlarged. Considerable economy should result from using this shaft as a main traveling and haulage way. At present the miners walk in along the river level to the Talisman shaft 1,650 feet, and those who work on levels 11, 12, and 13, then descend the ladderway. All this traveling is done on the company's time. Wages are paid from the time of entering to the time of leaving the mine. When the new arrangements are completed the men will descend by cages to No. 14 level and use trolleys to get to their work. Apart from the time saved there will be considerable husbandry of energy.

The horizons of former levels are shown on section, Fig. 1. The present system of development is to open a new level for each 200 feet sunk in the Talisman shaft measured along the dip. The levels are driven 8 ft. \times 5½ ft. in the clear and rise 9 inches per 100 feet. Connections are established by raising the winzes in the pay shoots at intervals from 100 to 150 feet. Should this development work disclose a barren zone which would generally be horizontal, and should subsequent stoping prove it to be extensive, an intermediate level is driven from the rise at the place where ore again becomes satisfactory. In this way the breaking of barren material is avoided as far as possible. The system of mining is by overhand stoping, the men standing upon broken country rock obtained from development work or by robbing the filled abandoned stopes overhead. Any waste material obtained from level 13 is hoisted by the rock skip to a hopper at No. 11 level, from which it is drawn for filling between levels 11 and 12. Between levels 12 and 13 the only material available is that obtained on level 12, and when this is horizontal so that waste will not pass down the rises, it is necessary to project rises in the hanging wall country rock to obtain material for filling. These rock rises are driven at a grade sufficient for the material excavated to run down in the stope with little assistance, about 50 degrees, and the contractors are paid for foot run of rise measuring 8 ft. \times 8 ft., or its equivalent in cubical contents. After starting they prefer to open not less than 9 ft. \times 12 ft. The price paid for this work is 25 shillings per cubic foot, and includes the distribution of the material in the stopes. The length of a rise depends upon the amount of material required and may be up to 80 feet. Though this is dead work and expensive as a filling, such rises have occasionally been useful in branch veins in the hanging wall country.

Stoping proceeds from the main rises in a series of slices, sloping at the angle found to be most convenient for shoveling the quartz and filling. Should a stope disclose an extension of ore horizontally, either north or south, then the end of that stope is carried on as an intermediate level until the material is no longer payable. For convenience in handling the ore, it may be necessary to rise from the level below up to this point. The filling is covered with planking before ore is shot down, and, when rich, sacks are placed underneath the planks to prevent loss of fine friable sulphides. Rock drilling in stopes is performed by machines as far as possible. The machine used is the improved No. 2 National, made by Taylor Horsfield, of Bendigo, Victoria. The piston is 3½ inches in diameter and has a 5½-inch stroke, giving approximately 400 strokes per minute with a pressure of 80 pounds of air at the machine. The men object to anything lower than 70 pounds. The valve of the receiver at the river level of the Talisman shaft is sufficient to blow off at 90 pounds and it is assumed that the loss by friction from here to the stopes is about 10 pounds. The machine weighs 300 pounds and the columns vary from 2 feet 6 inches to 11 feet 6 inches long with a jack-screw at one end. The drill steel has star bits, the starter being 2¾ inches in diameter, 1 foot 6 inches long,

and the finishing drill 1¾ inches and 7 feet long. The same machine and drill are used in development work. In ordinary faces a 4-hole pyramidal center cut is drilled and from 15 to 18 holes for the whole round.

Nobels gelignite, 1½ inches in diameter, and No. 6 detonators are used for blasting. During boring a water jet is employed, the water being taken from the rising main of the pump, the pressure varying up to 130 or 140 pounds per square inch according to the height of the stope. When blasting, a nozzle ⅜ inch in diameter is screwed on to the end of the compressed air supply pipe, and with this safety guard against waste, compressed air is used to clear away the smoke.

It is interesting to note here that one of the above machines was employed for drilling 6-inch holes for the foundation bolts of the large Cornish pump. The drills were of 2-inch diameter hexagonal steel. The starting bit was 6½ inches in diameter and the finishing drill 6 inches in diameter and about 7 feet long, weighing about 8½ pounds. The rate of progress was 1 foot per hour in hard andesite. A tripod was not obtainable and a jury rig was substituted in the form of a bar of 4-inch steam piping clamped on to two chairs or pedestals, each 3 feet 6 inches high, made from 2½" \times ½" round iron and bolted to an 8" \times 4" wooden base piece.

In order to accommodate the pump capstan, new winding engine, and pump engine, the chamber at the head of the Wood-

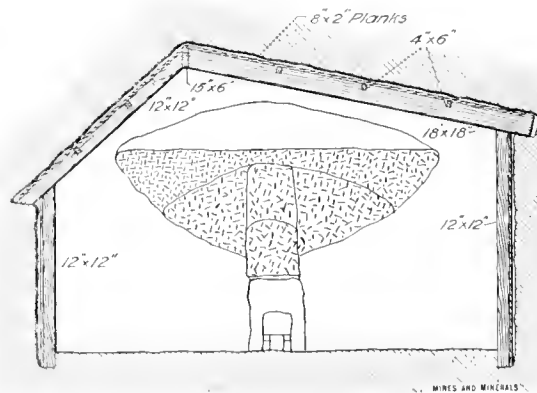

FIG. 2. METHOD OF EXCAVATING PUMP ROOM

stock shaft had to be enlarged. That portion which accommodates the pump engine is 100 ft. \times 40 ft. \times 25 ft. high and its excavation was interesting.

On the south end of the rock was a firm blue altered andesite decomposed to a softer brown rock in patches, especially adjacent to a small quartz vein which ran through the chamber at an acute angle to its longer axis. This softer material made the roof treacherous and it was deemed advisable not to use machine drills. The whole of the work was done by hand drilling and day labor.

From the existing chamber, a drive was projected to the full length of the required extension and this was met at right angles by a cross-cut from the river level thus providing the necessary ventilation. Leading stopes, with a height of 4 feet, were carried along this drive and also along that portion of the cross-cut which was to form the back or end of the chamber, Fig. 2. Light stulls were placed in hitches cut at 7 feet from the floor at intervals of 3 feet 6 inches. Across these were laid rough slabs to support the broken rock and the excess was drawn off into trucks by moving or withdrawing one or two of the slabs after the manner of a "China-man." Another stope about 5 feet high was carried along and then the sides were broken into about 2 feet above the stulls, the floor formed on either side being given an upward pitch. This procedure was repeated until the height of the center of the arch was reached and the necessary width obtained. Sufficient broken rock was always left in the stope for the men to stand on and conveniently sound the roof for treacherous or loose ground. A 6-foot barrier was allowed to remain between the new chamber and the

existing one until the timbering of the former was completed, an inclined rise being put through it so that timber could be hauled into the chamber by a hand winch.

The roof at the center and western ends was at all times heavy and it was thought safer to catch it up by rafters and close slabs before excavating the floor. Also, at this stage of the proceedings, the timber was more easily handled than would have been possible had the chamber been completely excavated.

Twenty sets of rafters were put in at intervals of 5 feet. These are of kauri 20 ft. \times 12 in. \times 12 in. at the south end where the span is 30 feet. The rafters increase on the west side of the chamber to 30 ft. \times 18 in. \times 18 in. toward the north end where the span widens to 40 feet, as shown in Fig. 2.

Hitches 2 feet high by 2 feet 6 inches wide were cut to receive the rafters, the depth of the hitches varying from 2 feet 6 inches to 4 feet according to the state of the rock. A centerpiece of 15" \times 6" hard wood was suspended by wrought-iron bolts 10 feet apart, let into the rock and firmly wedged in place. Against this centerpiece the upper ends of the rafters rested, 6" \times 4" spreaders or distance pieces were put between the rafters to prevent end movement, two or more being used to each space. Planks, 8 in. \times 2 in., were placed across the rafters and the space behind them filled with broken rock.

The roof having been secured, the end barrier was removed and the timbering over this portion completed and joined to that of the existing chamber, which was 40 feet high.

The broken rock was then removed from the chamber and the excavation of the floor portion commenced from the south end, the work proceeding in benches from the center so as to take advantage of the rill as far as possible. The walls were next secured by uprights of rata 16 ft. \times 12 in. \times 12 in., let into hitches 12 inches deep in the floor and the top end of the leg was cut to fit against the rafter and kept in place by a block nailed on to the rafter; 8" \times 2" kauri planks were placed behind these uprights and the space behind them filled with waste rock. An inside roof was constructed of 12" \times 1" boards lined behind with rubberoid in order to prevent slightly acid water from dripping on to the machinery.

The winding station was then widened on the east and west sides to accommodate a new winding engine and a capstan engine for handling pump rods. The roof was also heightened to enable the 40-foot rods to be lowered.

The completion of this chamber together with the erection of two Babcock & Wilcox boilers on an outdoor site excavated on the side of the gorge will enable the existing 240 feet of shaft to be utilized in the near future. Any outside site for a shaft would have been exceedingly difficult of access owing to the precipitous nature of the country and would also have entailed much extra sinking.

The ventilation is natural, the river level being the intake and the Talisman inclined shaft the upcast. The ordinary air-current at the intake equals 13,000 cubic feet per minute and the compressed air equals 3,500 cubic feet per minute, giving a total of 16,500. The number of men underground is 180 to 200. At the north end of No. 13 level the temperature is 71° F. and at the south end 75° F. (November, 1911). Sanitation is carefully attended to and no case of ankylostomiasis has been suspected.

All levels rise 9 inches per 100 feet. Surface water is picked up at No. 7 level and is utilized to drive the smithy blower at the mine buildings at the entrance of No. 8 level. Practically no further water is encountered until below No. 13 level, where the average flow is 25,000 to 30,000 gallons per hour, partly from the bottom of the shaft and partly from No. 12 winze. When the Crown mine was idle in 1909, there was much more water to be handled, about 41,000 gallons per hour, and it is quite probable that a cross-fissure connects the Maria reef system with that of the Welcome reef, the flow through it being somewhat restricted. The above water is dealt with by the following pumps:

Suspended at the bottom of the Talisman shaft are three pumps which are constantly in use and another which is kept in reserve; the capacities of these three being, respectively, 18,000, 12,000, and

11,000 gallons per hour, at a piston speed of 100 feet per minute, as ascertained by pumping into a cistern of known capacity at the flat of No. 13 level, the lift being 80 feet. From here the water is lifted 200 feet to the river level by two horizontal station pumps each of a tested capacity of 22,500 gallons per hour at 45 revolutions per minute. These pumps have two air cylinders, 12-inch diameter by 24-inch stroke with cranks at 90 degrees. Behind each air cylinder are two water cylinders (i. e., four water cylinders to each pump) 5½ inch diameter by 24-inch stroke on the same center line. The plunger of the first is driven directly by a tail piston rod from the air cylinder and that of the second is driven by two outside rods connected with the crosshead and passing one on each side through the cylinder flanges, which act as guides, to the rear end of the water cylinder. Each water cylinder with its valves, is a separate unit, and can be disconnected if necessary.

To prevent the formation of ice at the exhaust ports and dense fog in the exhausted air, the exhaust chamber has been tapped and a ½-inch pipe supplies water from the rising main to each exhaust port. This has effectually prevented the formation of ice and fog, but if the water supply be cut off from the ports, frost forms in less than 2 minutes. The air exhaust pipe is fitted with a drain pipe to carry this water back to the cistern.

An air-driven pump is installed in winze No. 12 below No. 13 level, and is supplied with air by a 4-inch pipe from the 6-inch main in the Talisman shaft. After the fire destroyed the old compressor house, this pump had to be stopped as the air was required for ordinary drill work. It was then found that running at 80 strokes (16 inches) per minute, it took about 161 cubic feet of air at slightly under 80 pounds, which was equal to the air required for 18½ of the drilling machines. This amount of air pumped 19,000 gallons per hour through a lift of 120 feet. The station pumps use the air expansively and take 190 cubic feet of air at 80 pounds for a capacity of 45,000 gallons per hour through a lift of 340 feet.

Four other pumps are held in reserve.

The new Cornish pump which is being installed in the Woodstock shaft is estimated to have a maximum capacity of 124,000 gallons per hour in three lifts of 250 feet each. 92,500 gallons per hour through first lift; 99,500 gallons per hour through second lift; 124,000 gallons per hour through third lift.

It has three plungers each 26 inches in diameter and with strokes of 10, 8, and 6 feet, respectively. At 10 revolutions per minute of the crank-shaft, this plunger gives displacements of 124,000, 110,400, and 102,800 gallons per hour, or, allowing 10 per cent. slip, which is probably excessive, a capacity of 124,000, 99,500, and 92,500 gallons, respectively. The engine driving this pump is a cross-coupled compound Corliss engine with cylinders 18 inch and 34 inch by 48-inch stroke running at 100 revolutions per minute. The flywheel is 10 feet in diameter, and by a rope-drive of sixteen 2-inch ropes it drives a 20-foot rope-wheel connected to the pump gear, thus giving a reduction of speed of 2 to 1. The big spur flywheel of the pump gear is 17 feet 6 inches in diameter and weighs 43 tons. The spur gearing, by which it drives the pump, effects a further reduction in speed of 5 to 1, a total reduction of 10 to 1. By this means the piston speed of the engine is kept reasonably high. Steam is supplied at 150 pounds per square inch by two Babcock & Wilcox boilers each of 1,619 square feet heating surface, superheaters each with 250 square feet, and chain-grate mechanical stokers. The exhaust steam goes to a jet condenser of barometric type.

The pump rods are in 40-foot lengths of Oregon pine and are, respectively, 24-inch, 22-inch, and 18-inch square for the three lifts. Butt joints are used with 15" \times 1" side plates, 18 feet long. The balance bob has a radius of 16 feet and will weigh about 40 tons. The pump column is 24 inches in diameter.

The mine trucks have a capacity of 16 cubic feet and the broken ore averages 25 cubic feet per ton of 2,240 pounds. One of the wheels on each axle is loose and the other fixed, one free wheel being on the right-hand side and the other on the left. This ensures easy running. The gauge is 18-inch and the rails are 14-pound. Ore

and mullock pockets are used, from which hoisting is done in skips. From the mine trucks the broken material is tipped between the rails directly into the hoppers and, to prevent large lumps from going through, a 4"×1" iron bar is secured between the rails, thus reducing the width of opening to 7 inches. Large lumps therefore have to be spalled, and in this way the doors of the ore pockets are kept in good order. The quartz hoppers have been made as large as could conveniently be arranged—about 75 tons capacity. Mullock hoppers are smaller—20 tons. They are excavated in the hanging wall. Formerly the bottoms of these pockets were lined with boiler plate, but this wore away quickly. They are now protected by old rails laid closely together after the fashion of grizzly bars. Fine stuff packs itself between them, and the protection afforded has prevented further wear.

The average load for an ore skip is 28.5 cubic feet (25 cubic feet equals 1 long ton) and for the mullock skip, 15.5 cubic feet. The bearers are 50 feet below the level floors and the tracks are laid with 30-pound rails set to 2 feet 5 inches gauge. Winding of ore is done chiefly on the day shift, but is not confined to it. A good average for the 8-hour shift is 150 long tons from the hoppers on Nos. 12 and 13 levels to No. 8 level. The winding engine is operated by compressed air. It has two cylinders, 12-inch diameter by 15-inch stroke, and gearing 5 to 1. The drum is 3 feet 6 inches in diameter and rope 1 inch.

From the hopper at No. 8 level the ore is trucked by a contractor to the aerial tram terminus outside the mine. The trucks are of 21 cubic feet capacity, and the way is laid with 28-pound rails at 2 feet 5 inches gauge. The horse is loaned by the company and the contractor has to get out 160 tons per day. Another contractor dispatches the ore to the battery by the aerial tram. A skip load is 15 cubic feet or 12 hundredweight of ore. The grade of the line is 18 degrees and the usual time taken for filling is 16 seconds and traveling 31 seconds, total 47 seconds—say 40 tons per hour.

With the exception of the Cornish pump, which is steam driven, all pumping and winding is done by compressed air. The pressure at the receivers at the compressor houses is from 90 to 100 pounds per square inch. The main to the receivers in the mine is 8 inches and the fall of pressure to No. 13 level, a distance of over 4,500 feet, is about 6½ pounds. By the time the air reaches the working faces the fall is about 15 per cent. The pipe line is closely inspected every day and two pairs of fitters make the rounds of the working faces and pipe lines to effect repairs.

采 采

Canadian Mining Institute

The Porcupine Branch of the Canadian Mining Institute held its first session at the King George Hotel, December 16. Quite a number of the men including Doctor Adams, Dean of McGill University, and President of the Institute, were present.

The following were elected officers of the branch: C. H. Poirier, Chairman; Alexander Smith, Secretary; Messrs. Globe, H. C. Meek, Pattary, and C. E. Watson were named as an executive committee.

A communication was read from the Toronto branch of the Institute respecting legislation affecting the employers' liability and workmen's compensation. W. F. Ferrier, of Toronto, led the discussion which was indulged in by several of those present. Henry Harrison, who has charge of the mill construction at the Dome mine, Porcupine, read an interesting paper on "Fine Grinding." Mr. Bateman a paper on "Sampling." Prof. A. G. Burrows read a paper on "The So-Called Slates of the Dome." Carl Reinhart, of Cobalt, talked on the "Researches in the Cross Lake District." Doctor Burrows referred to the discovery of scheelite and tungsten carbonate in a vein at the Jupiter mine where gold is found.

On the 6th, 7th, and 8th of March, 1912, there will be held the annual meeting of the Canadian Mining Institute, at Ottawa, at which there will be present members of the American Institute of Mining Engineers and a number of English engineers who will visit Porcupine and Cobalt.

The following is a list of the men present at the first Porcupine Branch meeting of the Institute:

H. G. S. Anderson, Cobalt; G. M. Colvocoresses, Gowganda; W. F. Ferrier, Toronto; George Glendinning, James E. Day, Toronto; R. W. Brigstocke, Cobalt; J. W. Shaw, C. G. Horton, Cobalt; Glen Anderson, Cobalt; M. F. Fairlie, Cobalt; T. W. Harpel, Toronto; Julius I. Wile, Chicago; J. B. Tyrell, W. S. Lecky, James McEvoy, Toronto; J. J. Byrnes, Sudbury; T. L. Goldie, Guelph; A. G. Burrows, Toronto; G. George Rapley, Orillia; W. F. Almy, Providence, R. I.; H. J. Deyell, L. A. Schmidt, E. V. Neilands, Cobalt; M. Campbell, C. G. Campbell, James Hylands, A. A. Smith, Norman A. Fisher, C. E. F. Galbraith, J. E. Leckie, T. G. Code, H. Collette, J. A. McVichie, John Seward, A. A. Cole, Cobalt; L. E. Bedford, Col. A. M. Hay, Haileybury; B. G. McBurney, Cobalt; H. S. Anderson, Toronto; T. H. Rea, Toronto; Carl Reinhart, Cobalt; G. W. Thomson, Pearl Lake; E. C. Hill, Toronto; H. C. Meek, Dome; W. W. Muir, San Francisco; J. C. Nichols, San Francisco; Henry Hasson, Dome; C. H. Poirier, Vipond; D. G. Allan, L. R. Timmins, Montreal.

采 采

The Joplin District in 1911

By Lucius L. Wittich

At the close of 1911 zinc and lead ores commanded a much higher price than at the beginning of the year. During the year there was an extraordinary increase in the tonnage of lead shipped from the Missouri-Kansas-Oklahoma district; and the new year commences with conditions throughout the mining district brighter than they have been since 1907.

The total valuation of zinc and lead ores was approximately \$13,000,000; the blende being valued at more than \$10,000,000, the calamine at more than \$400,000 and the lead at more than \$2,600,000. The aggregate valuation for the previous year was \$14,262,201.

The approximate shipments of blende aggregated 493,000,000 pounds; calamine 39,000,000 pounds and lead 90,442,110 pounds; the latter figure representing an increase of 1,000 tons over the aggregate shipments of 1910, which were, in turn, 233 tons greater than any previous year's shipments. In value, the 1911 shipments of lead ore were \$265,000 in excess of those of 1910, and more than \$150,000 in excess of the valuation of 1909, which was the greatest valuation of lead up to that year.

From the standpoint of development, 1911 was one of the most remarkable periods in the district's history, as it witnessed the beginning of the passing of the thin-sheet ground mines, the decrease in production of concentrate, which was counterbalanced, to a certain degree, by the opening of new mines in rich soft-ground areas, which, toward the close of the year, began to figure conspicuously in the production column. For years the sheet-ground mines had led by a good margin in the weekly production of both zinc and lead concentrates. Toward the close of 1911 a noticeable decrease in the output from these mines was apparent; yet their output continued to be sufficiently great to make apparent the importance of this kind of deposit. It is not because the sheet-ground areas are showing indications of becoming exhausted that this kind of mining is on the wane, to a slight extent; it is because the price of ore must permit of the low grades being mined and concentrated at a reasonable profit. Sheet ground, as a rule, does not carry a high percentage of blende, although the cleaned concentrate frequently assays high in metallic zinc. Mine operators vary regarding the figure at which profitable sheet-ground mining can be conducted, but the prevailing sentiment of the majority of the larger producers would fix a figure somewhere between \$10 to \$15 a ton, assay basis of 60 per cent. metallic zinc. Of course, with zinc ore selling for a greater figure than this still thinner deposits may be worked, and, with improvements in concentration processes, the possibility is ever present that the recovery of ore may be so perfected that greater margins of profit may be realized.

With the decline in sheet-ground mining came a revival in soft ground development at Thoms Station, Mo.; Carl Junction, Mo.; Galena, Kans.; and other smaller places. Outlying operations also

figured to some extent in the production of the district, Springfield, Mo., to the extreme northeast of the main developed area, having had a fair showing of concentrates for the year, the output being chiefly zinc blende, although some galena was produced. The new town of Lawton, Kans., north of the Galena, has reached a stage of development which entitles it to recognition. In Miami, Okla., while the 1911 production has not shown a marked increase over the previous year, new ore bodies, rich in galena, have been opened at much lower levels than any heretofore mined. The L. C. Church mine, in the extreme north part of the Miami district, has begun the shipment of concentrate. The Chapman & Lennan mine, on a lease of the Miami Royalty Co.'s land, has two shafts into the deep run of ore, and prospect drifting shows the formation to be extensive.

Since the beginning of 1911, shipments of both zinc and lead ores have shown a tendency to increase, and the price became stronger gradually, until at the close of the year zinc blende was worth more than \$50 a ton, assay basis of 60 per cent. metallic zinc. In the first week of 1911 blende shipments were barely in excess of 3,000 tons, calamine barely 100 tons, and lead about 500 tons, while the prices were \$40 to \$44 basis for blende, \$22 to \$24 for calamine and \$56 to \$58 for lead. The last month of the year the average weekly blende shipments were about 5,000 tons, calamine 400 tons, and lead 900 tons, with prices ranging as follows: Blende \$44 to \$48 basis with a top of \$51; calamine \$24 to \$28 basis with a top of \$35, and lead, \$60 to \$62.

The blende prices are those offered in the open market, where various smelting companies compete for the production. Ores selling on contract, based on the average price of East St. Louis spelter, brought a higher figure. The inauguration of the contract system was one of the important features of the year. The American Zinc, Lead, and Smelting Co. has bought regularly on this contract, being out of the market only for a few weeks in August and September, when the company's smelters at Deering and Caney, Kans., were shut down because of labor difficulties. The production of ores, however, from the company's mines at Webb City continued steadily, and when the labor difficulties were adjusted the company had an enormous reserve of blende from which to draw.

On the contract basis, blende is sold for \$37 a ton when the average price of zinc at East St. Louis, for the previous week, is \$5; for each one cent advance, per 100 pounds, in metal, the price for blende, per ton, is advanced 8.5 cents. For ores carrying little or no iron and small percentages of lead, premiums are paid, thus raising the basis price of first-class blende several dollars a ton. The first contract settlement was made for the week ending January 14, the ore bringing \$40.19 a ton. Spelter was then \$5.375. At the close of the year spelter had gone to \$6.80 and better, and the contract basis was in excess of \$52.45, while extra fine ore commanded as high as \$55.50, or \$4.50 greater than the highest figure paid in the open market.

That 1911 was a year of great prosperity for the smelters, and that the future held inducements, was indicated by the plans for new smelters and additions to old smelters, much work of this kind being commenced toward the close of the year.

The following table shows the companies buying zinc ore in 1911, the retorts being of 50 pounds capacity and capable of handling a charge every 24 hours:

	Retorts
Bartlesville Zinc Co., Bartlesville, Okla.....	3,456
Lanyon-Starr Co., Bartlesville, Okla.....	3,456
Cockerill Zinc Co., La Harpe, Kans.....	1,856
Vogelstein & Co., Gas City, Kans.....	2,560
American Z. L. and S. Co., Deering, Kans.....	3,840
American Z. L. and S. Co., Caney, Kans.....	3,648
National Zinc Co., Bartlesville, Okla.....	2,432
Beer, Sondheimer & Co., Altoona, Kans.....	3,480
Prime Western Spelter Co., Gas City, Kans.....	8,584
Mineral Point Zinc Co., Mineral Point, Wis.....	3,920
New Jersey Zinc Co., Palmerton, Pa.....	2,880
New Jersey Zinc Co., Bethlehem, Pa.....	5,104
Hegeler Bros., Danville, Ill.....	1,800
Matthiessen & Hegeler, La Salle, Ill.....	4,380
Edgar Zinc Co., St. Louis, Mo.....	2,000
Edgar Zinc Co., Cherryvale, Kans.....	4,800
Granby M. and S. Co., Neodesha, Kans.....	3,840
Bertha Mineral Co., Pulaski, Va. (Discontinued in 1911).....	1,400
Chanute Zinc Co., Chanute, Kans.....	1,280
Grasselli Chemical Co., Clarksburg, W. Va.....	5,670
Illinois Zinc Co., Peru, Ill.....	4,640
United Zinc and Chemical Co., Springfield, Ill.....	1,600

The output of some of the largest concerns is controlled by the American Metal Co.; Vogelstein & Co.; Beer, Sondheimer & Co., and others, and the impression has always been prevalent throughout the Joplin district that ore prices were agreed upon by the larger concerns. In rare instances only has the competition in the open market been sharp enough to indicate that such cooperation did not exist.

During the year the Lanyon Zinc Co. discontinued operations at its plants at Iola and La Harpe, Kans., 9,860 retorts being thus suspended. For the ensuing year more than 13,000 retorts will be added. The American Zinc, Lead, and Smelting Co. is building a new smelter of 4,000 retorts at Hillsboro, Ill.; the Bartlesville Zinc Co. is building a new plant of 3,200 retorts at Collinsville, Okla.; the Robert Lanyon Zinc and Acid Co., of Hillsboro, Ill., is building a smelter of 1,600 retorts, and the Prime Western Zinc Co. has started a new smelter of 4,680 retorts at Collinsville, Okla. This plant will be conducted under the firm name of the Tulsa Fuel and Mfg. Co. Several of the smelters now in operation may be closed this year.

乘 乘 Iron Ore in 1911

Preliminary estimates of iron ore sold in 1911 were sent to the Geological Survey by 26 of the largest iron-mining companies in the United States at the close of the year. The combined output of these companies represents more than 80 per cent. of the total production of the United States. From these returns it is estimated by E. F. Burchard, of the Survey, that the total quantity of iron ore marketed in the United States in 1911, not including stocks left at the mines, was between 43,000,000 and 46,000,000 long tons. This quantity represents a decrease of 22 to 24 per cent. of the sales for 1910, which aggregated 56,889,734 long tons. The output for 1910 was the largest quantity of iron ore ever marketed in a single year in the United States, and according to the present estimate the quantity produced in the year 1911 will take fifth place, being exceeded by that of 1910, 1907, 1909, and 1906, in the order named. It is estimated that of the ore produced in 1911, between 39,250,000 and 42,000,000 long tons was red hematite, the remainder consisting of brown hematite, magnetite, and iron carbonate ores. According to the returns received, the Lake Superior district, in Minnesota, Michigan, and Wisconsin, apparently produced between 33,000,000 and 35,000,000 long tons of red and specular hematite, which represents a decrease of 23 to 28 per cent. compared with the production of 1910—46,328,743 long tons.

In the Birmingham district, Alabama, the second largest iron-mining center, the production of iron ore apparently decreased 18 to 20 per cent. from that of 1910, the estimated production for 1911 being between 3,050,000 and 3,125,000 long tons, compared with 3,802,115 long tons in the preceding year. The ore mined in the Birmingham district consists of red and brown hematite in the proportion of about 4 to 1.

The production of iron ore in Tennessee and Virginia apparently decreased only about 16 per cent., according to reports from the principal producers in those states.

As the production of pig iron for 1911 may exceed 23,500,000 tons, a larger production of iron ore might appear to be required than has been estimated above, but it must be considered that at the close of 1910 there was 9,408,235 long tons of iron ore in stock at the mines in the United States, and that of this total 8,471,108 long tons was at the mines in the Lake Superior district. Just how heavily this surplus stock of ore was drawn upon in 1911 it is impossible to state at present, but owing to the increased activity in the manufacture of pig iron toward the close of 1911 it is probable that the 1910 surplus was in part cleaned up and that at the end of 1911 only a relatively small quantity of iron ore remained at the mines.

[The production of iron ore in New York state approximated that of 1909, when 1,015,000 tons found a market, most of which was magnetite. The production of New Jersey continued nearly up to the average, 543,000 tons.—EDITOR.]

Mines *and* Minerals

Vol. XXXII—No. 8.

SCRANTON, PA.—MARCH, 1912—DENVER, COLO.

Price, 25 Cents

PUBLISHED MONTHLY AT SCRANTON, PA.

ESTABLISHED 1881

INTERNATIONAL TEXTBOOK CO., PUBLISHERS

T. J. FOSTER, President S. P. ALLEN, Secretary E. H. LAWALL, Treasurer
RUFUS J. FOSTER, Vice-President and Manager

EUGENE B. WILSON, Editor ARTHUR J. HOSKIN, Associate Editor

WESTERN EDITORIAL OFFICE: 1221-1222 First Nat'l Bank Bldg., Denver, Colo.

CHICAGO OFFICE: 1006 Michigan Ave.

Entered at the Post Office at Scranton, Pa., as second-class matter

Address all business communications to MINES AND MINERALS, Scranton, Pa.

CABLE ADDRESS, "RETSOF, SCRANTON"

LONDON OFFICE: INTERNATIONAL BUILDINGS, KINGSWAY, LONDON, W. C.
SOUTH AFRICAN OFFICE: MANSION HOUSE CHAMBERS, ALDERLEY STREET,
CAPE TOWN.

NEW ZEALAND OFFICE: 63 DIXON STREET, WELLINGTON.

AUSTRALASIAN OFFICE: 83 PITT STREET, SYDNEY.

SUBSCRIPTION RATES

Single Copies..... 25 cents

Yearly Subscriptions, including postage:

To United States, Mexico, Cuba, Porto Rico, Hawaii, and Philippines..... \$2 00

To Canada..... 2 50

To all other countries..... 3 00

The date after your name on the wrapper is that of the month to which your subscription has been paid. If you do not want to continue your subscription after that time, kindly notify us.

Notice to discontinue or change of address should be sent to the Scranton office.

When notifying us of a change of address always give your FORMER as well as your present address.

TABLE OF CONTENTS

EDITORIAL—	
Overproduction in Mine Shares—Mine Rules and Mine Laws.....	449
NEW RUSSIAN MINE LAW.....	450
COAL MINING AND PREPARATION	
LONGWALL MINING IN ILLINOIS.....	451
ORE AND COAL MINING MACHINERY, by C. A. Tupper.....	454
TIPPLE AT DELAGUA MINE, COLO., by A. J. Reef.....	456
TRAOE NOTICES.....	458
SCIENTIFIC COAL MINE MANAGEMENT, by Sim and W. H. Reynolds.....	459
MINING SOCIETY NOTICES.....	460
STANDARDIZATION IN COAL WASHING, by Geo. R. Delamater.....	461
OBITUARY—	
William Washington Taylor—E. R. Buckley—James A. Snedaker—William C. Wetherill.....	465
JEFFREY-O'TOOLE COAL CUTTER.....	466
THE SMOKELESS COAL FIELO OF WEST VIRGINIA, by Edwin Ludlow.....	467
CONSOLIDATED COAL WASHERY AT SAGINAW, MICH.....	468
MICHIGAN COAL PRODUCTION, 1910, 1911.....	469
ECONOMY IN THE USE OF STEAM, by R. H. Rowland.....	470
PENN-MARY ROCK LARRY.....	471
AMERICAN INSTITUTE OF MINING ENGINEERS.....	471
CORRESPONDENCE—	
Grade for Rope Hauls—Panel System of Longwall—Allowable Error in Closing Survey.....	472
ELECTRICAL SYMBOLS FOR MINE MAPS, by H. H. Clark.....	473
DETERIORATION OF COAL IN STORAGE, by Horace C. Porter and F. K. Ovitz.....	475
EXAMINATION QUESTIONS—	
Tennessee Mine Foremen's, 1911.....	477
BOOK REVIEW.....	479
COAL DEVELOPMENT AT STEARNS, KY., by J. E. Butler.....	481
MANUFACTURE OF EXPLOSIVES IN 1909.....	482
ORE MINING AND METALLURGY	
LIMONITE PROSPECTING AND MINING, by Charlton Dixon.....	483
HOISTING AT CALUMET AND ARIZONA.....	485
DRY PLACER MINING METHODS, by Wilbur Greely Burroughs.....	486
EL PASO SHAFT, CRIPPLE CREEK, COLO.....	488
GOLD PRODUCTION IN 1910.....	488
THE SPECIFIC GRAVITY FLASK, by H. Stadler.....	489
THE HOLLINGER MINE REPORT.....	491
STOPE MODEL, by W. G. Zulch.....	491
MILLING THE TAM O'SHANTER ORE, by James M. McClave.....	492
PERSONALS.....	494
SHAFT RAISING IN HARD ROCK.....	495
ELECTROLYTIC ASSAY OF GOLD SOLUTIONS, by C. Crichton.....	496
PERVERSITY OF MINERS.....	497
LAKE SUPERIOR COPPER NOTES.....	497
TREATING ZINC CRUSTS AND DROSSSES, by Wm. Poole.....	498
ORE MINING NOTES.....	501
SHAFT SINKING BY CEMENT INJECTION, by A. L. Shrager.....	502
GENESIS OF SILVER DEPOSITS, by W. G. Matteson.....	504
CATALOGS RECEIVED.....	506
GOLD AND SILVER OUTPUT, 1911.....	506
NOTES ON HYDRAULIC PLACER MINING, by N. A. Loggin.....	507
SQUIBS—	
Recommended Appropriations for the Bureau of Mines, 455—Coke for Foundry Purposes, 458—New Zealand Mineral Oil, 465—Civil Service Examinations, 465—Shale Oil Enterprise in New Brunswick, 472—Iron in New South Wales, 482—To Break Hot Lead, 491 It Is to Laugh, 501—Bauxite and Aluminum Production, 503 Mechanical Efficiency.....	460

Overproduction in Mine Shares

THE discovery of gold in Porcupine came at a time when the cupidity of the people had been whetted by the wonderful output of silver from the Cobalt mines, south of Porcupine. All the elements of a first-class boom were in the hands of promoters and share speculators, who made the most of their opportunity. The excitement over Porcupine shares is on the wane, the first failure causing such a panic that the Toronto Mining Stock Exchange was compelled to close its doors temporarily.

While there are properties in the Porcupine district which should be remunerative, there are none as yet on a dividend-paying basis, by which the public can estimate their worth as an investment. The tendency to place fictitious values on shares of promising properties, practically using as a basis of valuation the excellent dividend-paying mines of Cobalt, is radically wrong from an ethical and business standpoint. In the Porcupine district, where there is one promising property there are probably 100 without any promise whatever, yet they have been carried on the crest of the wave of speculative mania which periodically occurs. One of the most promising properties, according to reports, is the Hollinger, which, among other things, is said to have had nearly \$2,000,000 expended on its development. The capitalization of the company is \$3,000,000, yet the shares are selling considerably above par. Taking the report of the manager of this mine, there is nothing to warrant any such price; for instance, he has overestimated the ore in sight one-third, and then assumes that 100 per cent. will be recovered. If 85 per cent. of the gold is recovered, and one-third reduction is made for over-estimation, the \$10,000,000 estimated value of the ore in sight will be cut in two. In addition to this deduction, it is conservative to say that 50 per cent. of the estimated value will be paid for expenses connected with mining and treatment, thus reducing the value of the ore to \$2,500,000. Another feature in connection with the Hollinger report, as it appeared in the Cobalt *Nugget*, is suggestive of the promoter and not the carefully prepared report of the mining engineer. The part referred to reads as follows: "Experience in similar rock formation in other parts of the world has shown that the veins continue to depths of 1,000 to 2,000 feet, so that there can be no doubt as to the conservatism of the estimated depth of the Hollinger veins, none of which have been estimated on a greater depth than 300 feet." Probably never in the history of gold mining has a deposit similar to that of Porcupine been worked to a depth of 2,000 feet, and since the veins are lenticular they are as apt to cut out with

depth as with length. When all matters pertaining to mining are referred to mining engineers by the investing public, the statement that "mining is a rocky road to easy money" will not be so true as at present.

來 來

Mine Rules and Mine Laws

SOME time ago six miners were killed at the Black Rock mine of the Butte-Superior Copper Co. in Montana by their disregarding rules. It appears that in their haste to reach the surface they disregarded the station tender's pleading not to go up with the tools and pushed past him on to the cage. According to the Montana mine law of 1903, no one has the right to give signals except the station tender, and this one broke the company rule, as he gave the signal to hoist with men and tools on the cage. If he had refused to give the signal until the men left the cage or if he had removed the tools, the accident would not have happened. He broke the rule at the lower landing and rode up to the 1,000-foot level without accident. Here he left the cage and the other station tender took his place and continued the infraction of the company's rules. Above the 1,000-foot landing the tools were dislodged in some manner so that they projected beyond the sides of the cage and thrashing about knocked the five miners and station tender off the cage to the sump below.

It would appear from the account received that miners have little regard for company's rules in Montana, and that frequently the companies do not enforce their own rules as strictly as they should. There are more men killed and injured in ore mines per 1,000 employed than in coal mines, yet little attention has been given the matter, because in but few instances are more than one or two killed by the same accident. This loss of life is unnecessary and a large part of it can be avoided if the ore mining states enact rational laws, which not only require reasonable precautions on the part of the mine owners, but also provide suitable penalties for infraction of local rules formed to protect the employes, even when the employes themselves violate them.

The American Mining Congress has taken upon itself to formulate a uniform metal-mine law to guard against just such accidents as occurred at the Black Rock mine. This law should be made operative in every ore-mining state, its necessity being clearly apparent to miners and operators alike. If no penalty is connected with its infraction, however, the law will be of little value.

來 來

New Russian Mine Law

The Russian Ministry of Trade and Industry has completed the law affecting the protection of workmen in mines. The law is divided into three parts, reviewing the regulations hitherto existing, with supplementary regulations for gold mines and a series of rules for special protection from results of electrical installations and the use of explosives in gaseous mines. The striking feature of the new code is the fact that regulations as to explosives in gas-

eous mines and electrical installations are practically novelties in Russian mining law, which hitherto has only dealt with these questions sporadically in the form of departmental decrees.

The most important features in the new law affect the paragraphs on the exit of workmen from underground workings, including the essential requirement that there shall be at least two exits and, besides the usual methods of approach by the miners, in cases where shafts exceed 75 sazhen in depth (505 feet) mechanical methods of exit shall be obligatory, besides the usual ladders. In raising or letting down workmen in the shafts, it is required that the hauling machine shall be furnished with two brakes; and at the same time the speed of the engine shall be automatically registered so that men shall not be raised at a greater speed than is formally permitted. A rule is attached that whilst men are being raised there shall always be a spare engineman at hand as well as the one actually engaged on the engine. In cases where the cage passes several levels the signaling must consist of both light and sound. All damages to ropes must be registered; acidulous water must be carefully removed from the shafts so that ropes may not become corroded. The diameter of hauling ropes is increased in proportion to the depth of the shaft. The speed is fixed for raising buckets and regulations are established for testing ropes required only for raising material.

Respecting ventilation, it will now be required that the maximum content of carbon dioxide in the air shall be reduced from 1½ to 1 per cent. and in cases of steeply inclined workings the ventilation must be effected through special airways. In mines with mixed explosive gases, observation is required to be more strict as to the content thereof in the air, according to the degree of danger. These degrees are three, and in the last of them compressed air must be used and special ventilators in preparatory workings. Ventilating doors are under special regulations, and for the lighting the workings lamps of simple type hitherto used must be suppressed, as well as all manner of percussion lighting apparatus, meaning thereby matches and the like.

Gold mines are included; but the regulations respecting these are not so interesting nor striking as in the case of the more dangerous forms of mining, but the regulations in respect to gold mines include a complete series of rules governing the operating of dredges on behalf of the workmen engaged therein.

An absolutely novel feature in Russian mining regulations is that which includes electrical installations; and every variety of these likely to be in use underground is subject to the strictest control, and of course special attention is paid to the danger of the electric spark igniting coal gas. All electric wiring has to be efficiently insulated wherever workmen might come into contact with it, as also boosters, meters, rheostats, etc. To complete the work of protection for those employed in the mines, a special chapter applies to the use of explosives in mines where explosive gas is abundant and where there is much coal dust. These regulations will effect quite a revolution in mining in Russia, as can be the more easily understood, when it is stated that the existing rules affecting explosives were issued in the year 1887 when explosive gas was little understood in Russian mines, and the rules affecting them considered chiefly the questions of the right of acquiring explosives, storing and carrying the same, without in any way dealing with the methods of employing them under dangerous circumstances. The new instructions insist that in gaseous mines where permitted explosives are employed, safety fuses must be used, and the explosion must be caused by detonators of determined strength. The rules govern the laying of the fuses, which must not be fired before the air has been officially investigated for its content of explosive gas, and in cases of particular danger, as in danger class No. 3, explosives may only be used with the express permission of the Mining Department and under conditions as stipulated in the new law.

The only exceptions to the immediate applicability of the law will be those cases where alterations in the plant, machinery or airways, etc., are required. Delays may be accorded for a period of as much as three years when such alterations, in the opinion of the governing body, appear to require such time for their effectuation.

COAL MINING AND PREPARATION

Longwall Mining in Illinois

Plan Used in Mines of Spring Valley Coal Co.—Method of Timbering—Building Cogs

In the United States longwall mining is little practised, while in England coal beds up to 7 feet in thickness are worked satisfac-

so follow in the footsteps of anthracite miners who in most cases were unable to work their mines longwall if they so desired on account of the hard brittle roof above the coal beds. In those sections of the United States where the coal is mined through drifts, longwall mining would require that the boundaries of the property be blocked out by entries, or that the center of the property be reached before mining commenced. The former plan would be the better; however, both would require a large capital outlay before mining

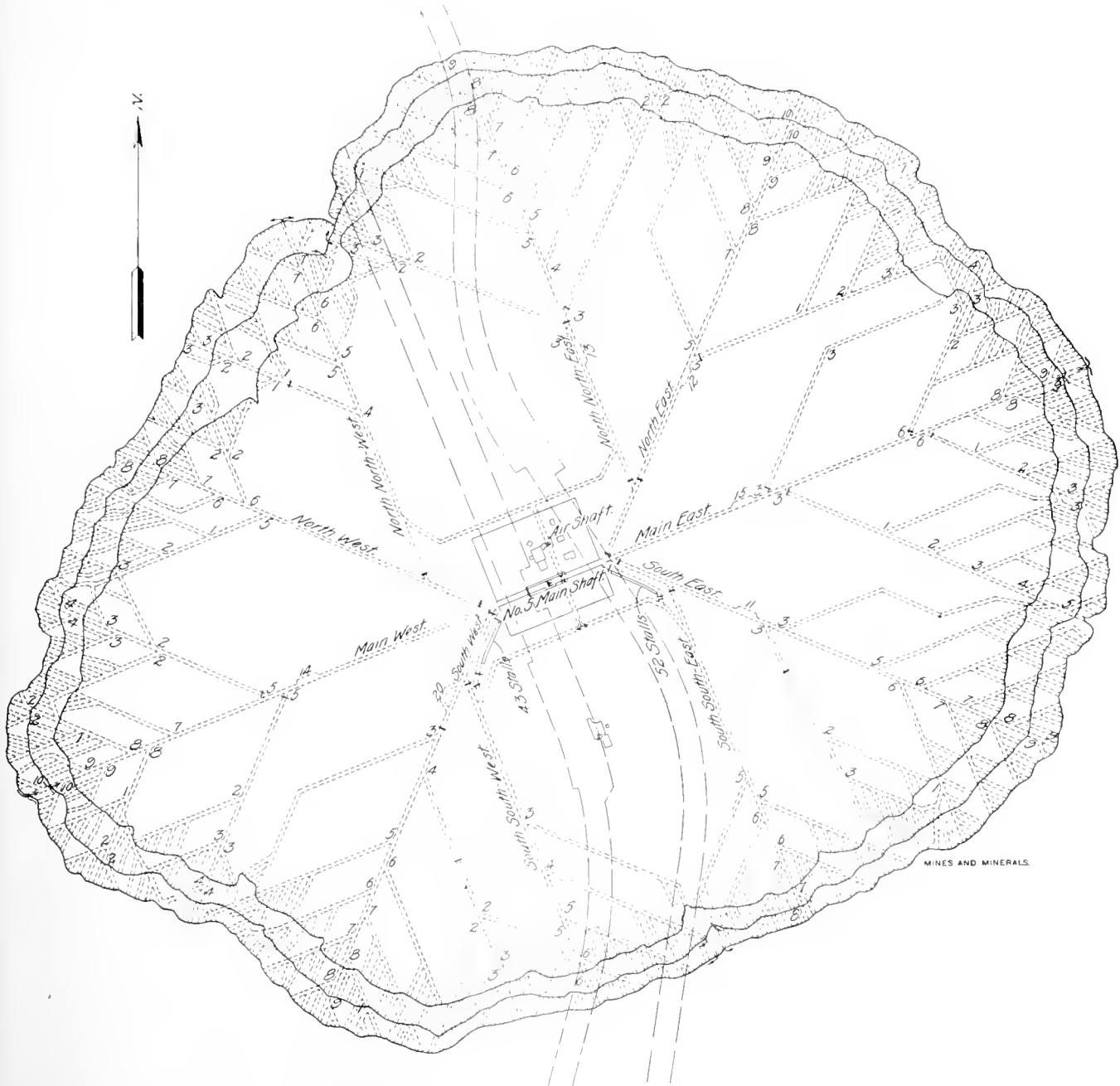

FIG. 1. PLAN OF SPRING VALLEY MINE

torily by the system. It may be possible to account for this conservatism by assuming that the majority of coal operators are unwilling to attempt a new system of which they know little, and

would yield a profit. In some sections of the United States the most economical plan of mining is denied the operator, even though he desired to follow it, for leases of coal land are made which demand

that the system of room-and-pillar mining be followed along certain lines specified in the lease.

Longwall mining contemplates the removal of all coal on the first attack, thus leaving no pillars to be recovered on the possibility of robbing after a while. In England longwall mining is practiced in two ways, one called longwall retreating, and the other longwall advancing. The latter method predominates, for the reason that less capital is locked up, and cash returns are realized long before the boundaries of the property could be reached to carry on the retreating systems.

The chief points to be considered in longwall mining are: cleatage in the coal, slip joints in the roof, and the building of pack-walls. In this system, if the coal is worked "on face" or "on end," less powder will be required than where it is worked "half end on," but the advancing line of face should always be at an angle with the roof joints. The question of whether the face should be in one continuous line or stepped, will depend upon the cleatage and the system of working, and may be varied to suit conditions if it effects the support of the roof and the size of the coal.

Iowa and Illinois have thin coal seams that are worked longwall at a number of mines. In Bureau, Grundy, and La Salle counties, Illinois, the Scotch, or

45-degree system of longwall advancing has been practiced for more than a generation. Here the coal is undercut by picks, and spragged. It is possible that in some mines in Illinois longwall coal cutting machines are used, as they are in Iowa. In the Spring Valley mines, however, the miner does the undercutting with his pick. If the conditions are such that the roof is bending down after the mining, which is ascertained by sounding the coal with the side of the pick, the undercut need only be from 18 to 24 inches; and if left in this condition over night, and the sprags are knocked out the coal will come down in blocky pieces owing to the weight of the roof bearing on it. In case the roof is not working properly, but hangs after the last prop is pulled, deeper undercuts must be made, and then if the coal does not come it is wedged down.

The space immediately back of the face where the miner works is held up by props. In the Spring Valley mines the props are left standing until they break, and none are recovered. It is the usual custom in working longwall to stand three props staggered behind the miner, and, as soon as there is room between the first post and the face, to pull the rear prop and reset it in front.

The Spring Valley Coal Co. has five mines in the vicinity of Spring Valley, Ill., from which over 1,000,000 tons of coal is shipped annually. The No. 3 coal bed of the Illinois Geological Survey is 42 inches thick in this vicinity, and is of such excellent quality it is the only bed mined by this company. It is also better developed than the No. 2 seam 172 feet below, which is worked extensively in La Salle County.

Below the coal there is approximately 6 feet of fireclay, immediately above, about 15 feet of yellowish brown clay shale carrying pyrite, and above this 3 feet of black shale. The clay shale air-slacks readily and because of its unctuous feel is locally termed "soapstone." It comes down in a satisfactory manner and forms an arch over the roadways. The No. 3 bed, being 421 feet below the surface, is reached by shafts; therefore, a description of No. 5 colliery shafts will suffice for all.

The hoisting shaft is 13 ft. 8 in. x 17 ft. 4 in. outside and 12 ft. x 16 ft. inside. The wall plates are of 6" x 8" sticks placed skin to skin with 6" x 8" buntons to separate the shaft into two compartments 5 ft. 7 in. x 8 ft. The escapement, or air-shaft,

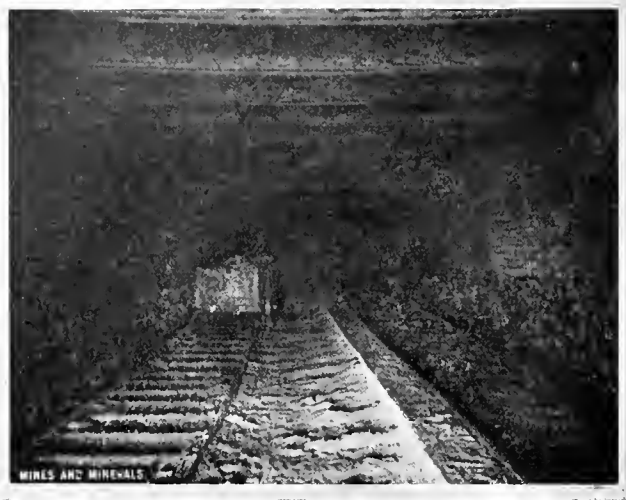

FIG. 2. SHAFT BOTTOM ENTRY

Geological Section at La Salle, Ill.		Feet	Inches
No. 1	Drift clay and gravel.....	13	
No. 2	Green and purple shales, with thin bands of impure limestone and a thin coal seam.....	60	
No. 3	Limestone, in two beds.....	27	
No. 4	Blue, green, and gray shales.....	215	
No. 5	Black slate.....	8	
No. 6	Coal No. 4.....	4	
No. 7	Fire and potter's clay.....	16	
No. 8	Clay shale.....	14	
No. 9	Coal No. 3 would be about here if 172 feet above No. 2.....	3	6
No. 10	Fireclay.....	5	
No. 11	Sandstone.....	5	
No. 12	Clay shale.....	54	
No. 13	Brown shale.....	90	
No. 14	Black slate.....	2	
No. 15	Sandstone.....	14	
No. 16	Black slate.....	2	
No. 17	Clay shale.....	14	
No. 18	Coal No. 2.....	3	10
Total depth.....		550	4

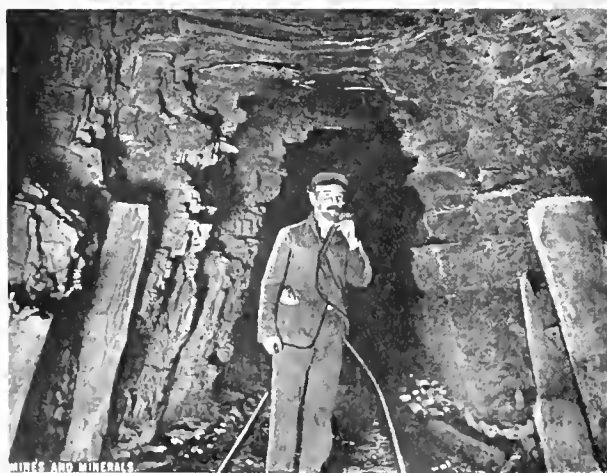

FIG. 3. ENTRY WITH COLLARS REMOVED AFTER ARCHING



FIG. 4. TIMBERS AND LAGGING SHOWING FUNGUS GROWTH

9 ft. \times 13 ft., has two compartments, the airway being 6 ft. $3\frac{1}{2}$ in. \times 7 ft. $10\frac{1}{4}$ in., and the stairway 5 ft. \times 8 ft. Between the airway and stairway a partition is constructed of 1-inch rough boards nailed to the buntons and covered with $\frac{3}{8}$ -inch matched boards to make it airtight. Ventilation is by a $12\frac{1}{2}$ \times 5' blowing fan, direct connected to a 16" \times 15" engine that makes at present 140 revolutions per minute and furnishes 110,000 cubic feet of air with the water gauge standing at $1\frac{1}{2}$ inches, equivalent to a ventilating pressure of 7.8 pounds per square foot. All fans of this company have recording charts, which show the water gauge during the 24 hours.

In the mine about the shaft a substantial pillar of coal 500 ft. \times 500 ft. is left, through which a main entry is driven east and west, as shown in plan of mine, Fig. 1. The shaft-bottom entry is two tracked, the cover above being supported as shown in Fig. 2, by steel I beams resting at the ends on brick and stone walls. From the east and west main entries beyond the shaft pillar, 45-degree slant entries, designated as Northeast, Southeast, Southwest, and Northwest, are driven as permanent haulage roads. These and the main entries are 30 feet wide with 10 feet of building or packwalls on each side, thus leaving the entries 10 feet wide. As the roof of the haulage road sinks as the face advances, it is brushed and timbered with three-piece sets near the face. After the roof has arched, as shown in Fig. 3, the collars are removed by company men and the road retimbered. Sometimes these arches have to be filled up with lagging, as shown in Fig. 4, in order to catch up the roof, which would otherwise fall and crush the timber sets in time. At turnouts, or what are termed "lyes," timber sets such as shown in Fig. 6, are needed for supports. Those shown are of special interest, because the squared collars have been in place 22 years and are still sound, while the timbers shown in Fig. 4 are rotting after 14 months use. The difference in the life of these timbers is due to their respective situations in the mine, the latter being in the return airway, which is damp, and the former in the intake, which has pure dry air. At regular distances from the timbered entries mentioned, other entries are turned from them at angles of 45 degrees, boxing the compass at North-Northeast, South-Southeast, South-Southwest, and North-North-

west. Where permanent entries meet, the angle or lye cogs shown in Fig. 7 are built to support the roadways. The method of building cogs is better shown in Fig. 5, which is a side view of another cog; the timbers in both cogs are sound after being in place 20 years in Spring Valley No. 1 mine.

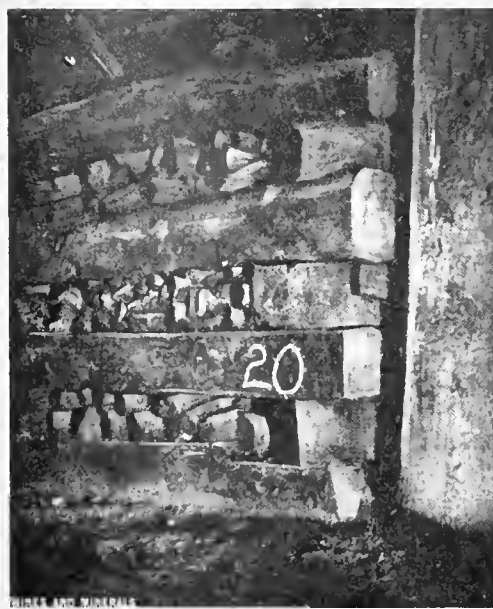

FIG. 5. COGS OF SQUARE TIMBER 20 YEARS OLD

The nomenclature of entries in these mines may be illustrated by stating that the cog shown in Fig. 7 is at the junction of the second left entry, off the third left entry, off the main Southwest entry, which goes to show that the mine boss is an underground mariner as well as an expert miner. Usually, slabs of rock are employed for rock filling, but if good stone is not available round poles are driven in between the crib timbers. It will be seen from Fig. 1 that those angle or gob roads which branch at 45 degrees from the main haulage roads are designated by points of the compass and numbered 1, 2, 3, etc., but wherever the coal has been removed and the roads closed, as for instance on South-southwest, the first number on the left is 3 and the first on the right 5. These gob entries are turned off on 225-foot centers, which gives the gateways to the rooms 60-foot centers, and the

rooms 42 $\frac{1}{2}$ -foot centers when pack walls are 9 feet wide. Experience has shown that a gateway to the face that exceeds 225 feet in length must have its track lowered or the roof rebrushed before completion; therefore, the gateways to gob entry 3 are abandoned as soon as they are cut off by the gob entry 4, etc.

The coal is mined from the shaft pillar out (longwall advancing), and the entries, as in the Scotch system, do not advance beyond the coal face. The outside circular line on the map is the coal face at the survey period, and the dotted lines show the entries and rooms of the mines. The miner's working place is 42 $\frac{1}{2}$ feet wide with his roadway in the center, so that his farthest coal is approximately 21 feet from the car. This coal he is obliged to handle more than once to load it into his car. The miner makes an undercut of from 8 to 18 inches in the fireclay with a pick, throwing the chips made back among the timbers, after which he sprags the coal and allows it to remain until next day, when he loads it out, and undercuts the other side of the room. The miners brush or take down 24 inches of the roof in their gateway, which makes it about 6' \times 6 $\frac{1}{2}$ ' area. The rock from the roof of the roadway they use for



FIG. 6. SQUARED TIMBERING AT "LYE"



FIG. 7. COGS AT MEETING OF PERMANENT ENTRIES

"building," that is, making the packwalls each side of their gateway. The miners lay their own tracks, set their own props, do their own building, and load their own coal. The company drivers get the loaded cars at the face and leave the empty cars at the nearest switch, from which place the miners push the empty cars to the face.

The advantages to be derived from longwall mining are: It produces the largest percentage of lump coal of any system so far devised; it permits the largest recovery of the entire coal seam; it is economical in thin beds; and it restricts the use of explosives to a minimum. At the Spring Valley Coal Co.'s No. 5 mine no coal is broken by explosives. Of course there are disadvantages to the system, and in many situations these would more than balance the advantages. Take for instance the following conditions: Roof too strong; building material scarce; cleatage and roof joints unfavorable; where the roof of a seam consists of 5 or 6 feet of soft rubble—more of the nature of soil than stone—which falls in the face, and is of no use for building packs; frequency of faults; and at coking collieries where lump coal is not particularly wanted.

The writer is indebted to F. D. Chadwick, engineer, Spring Valley Coal Co., for the information and illustrations in this article.

采 采

Kick-Back

In ordinary practice it is customary to have a special switch just before the tippie is reached upon which cars of rock or dirt may be side tracked and passed around the tippie to the rock dump.

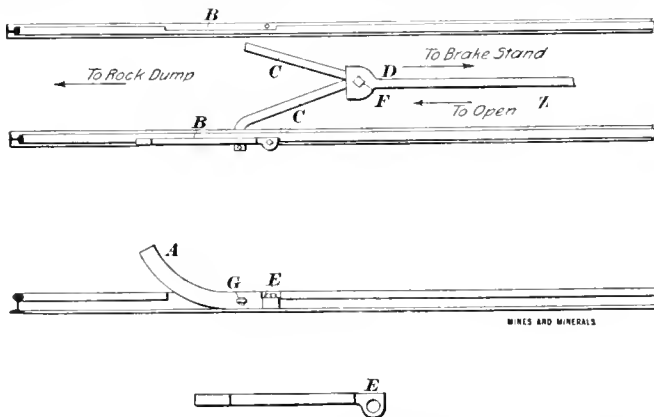

A device at the Heaton mine, Gibson, N. Mex., does away with this extra switching and saves considerable time in handling waste material.

The horns, *A*, of the kick-back are made of 1"×4" iron, reinforced by other pieces of iron where they are under the rail. These horns fit in slots cut from the rail as shown at *B*. The end of each horn is shaped as shown at *E*, where it is movable about a bolt through the rails. The pieces *C C*, are of ½"×2" flat iron. Holes are punched through their ends and through the end of the brake rod *D*. The two pieces *C C* and the brake rod *D* are held together by a bolt at *F*, about which they are movable. At the end opposite *F* the bars *C C* pass through slots cut in the rail at *B*. They are fastened to the horns *A* by a bolt, about which they are movable, as shown at *G*. The rod *D* passes to an ordinary switch stand placed convenient to the dumper at the check house.

When a car of rock or dirt is found in the regular trip the horns of the tippie are opened and the car passes over it. The horns of the kick-back are then opened by throwing the brake rod (operated by the lever at the switch stand) in the direction of the arrow *Z*. The car naturally passes through and on to the rock dump, when the horns are closed by pulling the brake rod in the opposite direction from that of the arrow *Z*. In event of the loaded trip not being under control as the tippie is approached, it may be passed through the dump and the kick-back and be stopped before any damage is done.

Ore and Coal-Mining Machinery

Its Similarity, and What Each Branch of the Industry Owes the Other for Its Development

By C. A. Tupper*

There has been observable, within the past few years, a widening of the breach between coal and metal mining, and a disposition on the part of many men engaged in the latter to look down upon the former as an inferior class of mining. This view, however, cannot be entertained by any one who has made a study of actual conditions. In fact, he will discover early in his investigation that the colliery operators have been by far the more progressive of the two; that metal mining owes to coal mining a debt which has been growing rather than decreasing and will perhaps never be fully repaid in kind.

At the same time, it is apparent that opportunity exists for an interchange of information and experience which renders close cooperation between men engaged in these two classes of mining not only practicable but highly desirable.

The earliest steam engines, as is well known, were pumps for dewatering pits in Cornwall, and what is known as the Cornish pumping system is largely in use to this day. Steam pumps for service in and about coal mines have, however, been generally developed along more modern lines and colliery practice has steadily maintained an equal if not leading position in this respect as compared with that of metal mines.

When the subject of motor-driven pumps began to be agitated, nearly a century after the construction of the first steam-pumping engine, colliery engineers were again the pioneers in their application to mining service. This time the movement originated in Germany. Here the coal mines are close together. For example, in the Dortmund, Westphalia, district, which covers about 1,390 square miles, there are over 200 collieries, with a yearly production of 90,000,000 tons, and the emulation in bringing about improved methods at the different properties is always keen. Consequently, progress has been correspondingly rapid.

In the construction and operation of steam hoists for shallow workings, or mines of moderate depth, colliery practice has been analogous to that of steam pumping, in that it led the way and has maintained at least equality of place. For shafts of great depth, such as those of some of the copper properties of Lake Superior, the metal miners have, naturally, passed collieries in the size and character of the problems to be solved, although some collieries are now worked to depths of several thousand feet.

With the application of electricity to hoisting service the history of colliery operation has, however, been one of further advance, and the lead gained over metal mining by the progress made in this field is only just beginning to be closed in upon by the latter. The greatest progress has thus far been made in Europe, and it has been most highly developed there in the principal colliery districts, what is known as the Ilgner system of flywheel equalizers, with Ward Leonard control, being now most generally used.

Pneumatic drills found their first application in collieries and the use of electric drills for coal mining antedated by some years their recent installation in metal mines. The same is true of cutting and tunneling machines; but, as these are not adapted to work in metalliferous mines, except under special conditions, the comparison is not especially pertinent.

Ventilation by mechanical means was, of course, forced upon colliery operators by the emission from the veins of dangerous gases in large volume; hence, this branch of mine engineering naturally received the greatest amount of attention in collieries; but many metalliferous mines, particularly those from which sulphides are recovered, now find it desirable to install similar plants. In the design of these they have, of course, the benefit of the extensive experience of the coal miners.

* Consulting Engineer, Milwaukee, Wis.

For the removal of coal or ore underground the methods used in collieries and metal mines show wide variations, according to divergent conditions; yet there has been a very considerable intermingling of experience. The room-and-pillar system and long-wall method, with their several modifications, were outgrowths of colliery work; while slicing, milling, and scrambling are more distinctly metal mining. Operations such as shaft or adit driving, tunneling, drifting, stoping, raising, etc., are, of course, common to all classes of mining. The hydraulic back-filling of old workings, which has recently been inaugurated in Germany, is purely a colliery development first used in the anthracite regions of Pennsylvania, and holds out possibilities for the avoidance of waste or tailing heaps elsewhere.

The sinking of shafts through wet or treacherous ground was a result of the studied effort at German collieries to reduce expenses and avoid mishaps from caving in. Of concrete shaft lining, the writer is not so sure where credit belongs, but believes that it should be assigned to the same source. Both systems, which bear a close relation, are now being used for metal mines where the soil formation makes them desirable.

The use of underground-haulage machines, whether propelled by electric or gasoline motors, was widely adopted in collieries before being taken up by many metal mines. The latter are now extending the system to include over-head tramping, and for stock piles, waste heaps, etc., with appreciable economies as a result. Underground, however, there are still lessons to be learned from the collieries, where material is brought to the shafts so regularly that hoisting can be done much more continuously than in the average metal mine.

For the installation and care of electrical machinery placed under ground, better provision generally has been made in collieries than in metal mines, and the systems of wiring and connections have been more carefully worked out, with use of a higher grade of material. This was necessitated by the danger in coal mines from the ignition of explosive gases; but it has also resulted in less interruption to service from avoidable mishaps to electrical equipment; and the metal miners who are beginning to take similar precautions from that standpoint alone find that it pays them. Here, again, the experience of collieries gives them systems of installation all ready to their hand.

Classification by screening was undoubtedly practiced to a large extent at anthracite coal breakers long before it was adopted for screening ore. An excellent witness of this is the fact that the large manufacturers of screen frames and perforated metals, today, built up this department of their business mainly from the colliery and quarry trade. When we turn to washing and jigging, the credit for pioneer effort is not so easy to place. Coal washing was actually entered upon somewhere in the 80's, being again the outcome of European practice; but there were few noteworthy examples of it before, say, 1875, and its general development has been since 1880. On the other hand, hydraulic separation of ore from gangue, with classification and concentration by jigging, has been extensively used by metal miners for many years. The influence of the collieries has here been felt chiefly in an improvement of processes, and one method of dressing a product reacts upon the other.

Most of the problems connected with the conveying and surface hauling of material, whether by means of larries, elevators, belt or bucket conveyers, aerial tramways, cranes or overhead crawls, were carried to their present remarkable state of mechanical efficiency mainly at collieries. Of recent years the work at collieries has been paralleled in installations made for ore-handling plants; but the former was in an advanced state of development long before the owners of metalliferous mines perceived the economy of similar investments. On the other hand, the erection of steel head-frames and shaft houses improved crushing plants and other head-works originated at metal mines, and have increased greatly at coal mines.

To metal miners must be given credit, also, for working out the problems of hoisting heavy loads in balance from extreme depths, and this experience has been of material value to coal miners as the depths of their operations have increased.

The use of steam shovels for stripping and loading iron and copper ore has, too, been taken up by coal miners where beds or seams lie near the surface, as well as in the recovery of phosphate rock, clays, shales, etc.

The efficiency of the pneumatic drill has been greatly increased as a result of the experience gained in metal mines and quarries, with corresponding benefit to colliery economy; and the history of the electric percussion drill from this time forward will undoubtedly show similar results.

The wider use of pumps handling gritty or acid water has stimulated efforts on the part of manufacturers to find materials for their construction which resist both erosion and corrosion. Carrying this idea further, it will be readily seen that, wherever metal miners have taken an idea from collieries and adopted it or elaborated upon it for their own requirements, the result has been a simultaneous development, which cannot fail to react favorably upon coal-mine equipment. Not least among these mutual benefits, in connection with the operation of motor-driven machines, has been the successful solution of many problems involving automatic or distance control.

There are, of course, in metal mining, problems connected with the concentration and reduction of ore which have no parallel in colliery operation; but the former in its more complicated phases gets beyond the pale of mining, considered as the production and grading of raw material from the earth, and the latter is entirely within the domain of metallurgy, a branch of industry quite distinct from mining.

All of the service above enumerated requires, of course, the manufacture of a large quantity of machinery and other apparatus. Among the firms engaged in this class of work there has also been a tendency on the part of some, in recent years, to draw away from the colliery field and concentrate their attention upon metal mining, where the related lines of metallurgy afford opportunity to dispose of a greater variety of equipment. To the writer this would not seem to be the part of wisdom, except for manufacturers remote from the colliery trade. Aside from restriction of the field, which may be desirable as a business policy, they lose the benefit of much valuable experience and are apt to be behind the best practice in their designs. In the two classes of trade there are, of course, distinctive differences; but the equipment used, when not identical, is near enough alike to enable designs to be worked out side by side, with common advantage to all.

Meetings where the coal and metal-mining interests come together, like that of the American Mining Congress held in Chicago, will do much to cement their mutual relations; and there ought to be, in other directions, every possible encouragement for an interweaving of experience and progress.



Recommended Appropriations for Bureau of Mines

In the general estimate for appropriations for the fiscal year 1912, which begins July 1, 1912, Secretary of the Interior Walter L. Fisher has recommended the following items for the Bureau of Mines: For the investigation as to the causes of mine explosions, methods of mining, especially in relation to the safety of miners, the appliances best adapted to prevent accidents, the possible improvement of conditions under which mining operations are carried on, the use of explosives and electricity, the prevention of accidents, and other inquiries and technologic investigations pertinent to the mining industry, \$360,000.

For the investigation, analyzing, and testing of the coals, lignites, and other mineral fuel substances belonging to or for the use of the United States, \$135,000.

For investigations into the treatment of ores and other mineral substances, with special reference to the prevention of waste in the mining and utilization of important mineral resources, \$100,000.

For the investigations of the coals of Alaska, with reference to their mining, transportation, and utilization, \$50,000.

Tipple at Delagua Mine, Colorado

Novel Haulage and Other Features of New Tipple at the Mines of the Victor-American Fuel Co.

By A. J. Reef*

On October 6, 1910, the tipple, washery, boiler house, and blacksmith shop of the Delagua mine were burned completely. Some interesting work was done in the way of rush construction to get the mine running again, which was accomplished in 8 days. The subject of this description, however, is the new tipple, which permanently replaced the old.

This is a double tipple, receiving coal from both sides of a narrow cañon and dumping over two sets of screens, as shown in Fig. 1. The tipple is 625 feet long, 24 feet wide on the north side, and 34 feet wide on the south, and at the horns of the dumps is 33 feet 9 inches above the railroad tracks beneath, measuring top of rail to top of rail.

Mine-car tracks are 36-inch gauge, and on the north side are three in number, the loaded track in the center, the locomotive passing track 7 feet to the west, and the empty track 8 feet to the east. On the south side of the tipple, as shown in Fig. 6, coal is received from two sources, a rope haulage which pulls coal from a slope at *a* on the north side of the cañon across a bridge *b*, and lets it down onto the tipple *c* on the south side, and from electric locomotives bringing coal directly from the south side mines *d*. Because the rope pulls longer trips than the locomotive, and to make each haulage independent of troubles on the other, the south side of the tipple has four tracks, a loaded and empty for each haulage system. No locomotive passing track is provided, but since the total amount of coal brought in by the locomotives on this side is small, time can be taken for the locomotive to switch around each trip before reaching the tipple, and push it in.

The old tipple had been considerably lower than this one, and since the railroad tracks remained at the same elevation, and the ends of the tipple could not be raised without considerable expense, an entirely gravity system of handling cars on the tipple seemed

*Assistant Chief Engineer, Victor-American Fuel Co., Denver, Colo.

out of the question. Car hauls shown in plan, Fig. 2, with gravity dogs furnished by the Link-Belt Co. are therefore used to feed the cars into the scales and dumps. The original hauling power delivers the loaded trip on the tipple so the front car can be engaged by the car haul. In order to make sure of this delivery with the rope haul on the south side, the car haul on this track was made 66 feet long center to center. This has since been found unnecessary, as the momentum of the incoming trip readily carries it to the head end of the car haul; the other two hauls are 17 feet centers. The dogs are 10 feet centers on Link-Belt car-haul chain.

The cars in the trips remain coupled until past the car hauls, the whole trip being steadily moved forward, and individual cars

being cut loose when past the car haul, and run over the scales and dump. The grade from car hauls to dumps is 2.5 per cent., so that the cars run by gravity. The speed of the hauls is 15 feet per minute, and the cars stand coupled therefore at about 10-foot centers, so they are fed and readily handled at the rate of one and one-half cars per minute. The hauls are favored by the grade of the track, which is 1 per cent. on the south side and $\frac{1}{4}$ of 1 per cent. on

the north side; consequently no trouble is experienced in handling trips of 30 mine cars, or a gross weight of 190,000 pounds; the mine cars weighing 2,300 pounds empty, and about 6,300 loaded.

An odd feature of the car haul on the north side is that electric locomotives coming in at the head of the trips pass over it, leaving the head cars of the trip standing on it, before cutting off and backing into the motor track, as shown in Fig. 2. It was first attempted to permit the locomotives, whose clearance above the rails is less than 2 inches, to pass over it, by lengthening the dogs and depressing the chains, so that when the dogs were down they would clear the locomotives, and when up would catch the axles of the cars. While this arrangement worked well enough on trips of 20 cars, it was not satisfactory on longer ones, as the leverage on the long dog tended to kink and break the chain; so the very simple expedient was adopted of leaving out one dog so that with the car-haul chain in a certain position no dogs stand above the rail; the haul is regularly stopped in this position and the locomotive safely passes over. The haul is long enough, so that the dog just behind the blank space in the chain catches the second car behind the one just leaving the car haul and no jerky motion or uneven feeding results.



FIG. 1. TIPPLE, NORTH SIDE OF OVENS

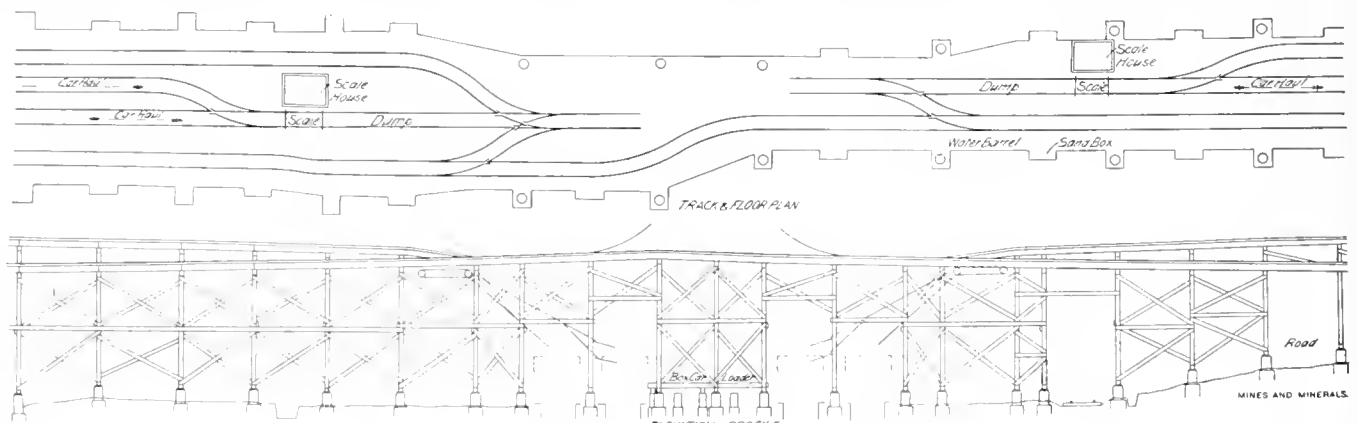

FIG. 2. PLAN AND ELEVATION OF TIPPLE AT DELAGUA MINE

The coal is weighed in pit cars on 5-ton scales with dial, and passes to Phillips cross-over dumps. From these the empties pass to kick-backs, and back to their respective empty tracks on gradually decreasing grades, starting with 3 per cent. and running out level at the bottom of the empty basins, as in Fig. 2.

Only two sizes of screened coal are loaded at this plant, so stationary bar screens are employed, but in order to insure good screening, they were made 7 feet wide, with screening surface 20 feet long, set on 29-degree pitch. The main objection to a stationary screen is that the coal passes over it in a mass and fails to separate. This was overcome by installing a feeder between the dump and screen. This feeder is really a hopper with stationary steel sides and an apron conveyer 5 feet wide and 10 feet long for a bottom. These conveyers were furnished by the Jeffrey Mfg. Co. and were originally installed as shown in Fig. 4. It was expected that practically all coal would be discharged onto the screen, the conveyer being recommended by the manufacturers as capable of such a discharge, and what little failed to be so discharged would be caught by the slack chute. This worked very well when running screened coal, but when mine-run orders were being filled, the slack going down the chute was considerable in quantity and not readily disposed of; so the conveyer was changed as in Fig. 5, and all trouble from leakage disappeared. The original speed of 20 feet per minute was found to be too slow to take the coal away from the dump, and the conveyer was speeded up to 40 and then to 60 feet per minute, and even at this speed it distributes the coal uniformly on the screen and exceptionally clean lump results. C. F. & I. screen bars are used, and the screen-bar rests are slotted on both sides so that two spacings are available by simply turning these rests over.

Victor box-car loaders, built by the Link-Belt Co., are provided for loading lump and mine-run in box cars.

The slack chutes have their sides run up to the screens, and are hoppers at the bottom end, so that by closing a sliding door, about 5 tons of slack can be held in each, while the railroad car on the slack track is being changed. This eliminates a large part of the delays in dumping on account of changing railroad cars.

Two railroad tracks pass under each screen, and as is customary with this company, track scales are immediately under the screens. By the use of rods and knee levers all scale beams are in one house, located between the tracks, about 12 feet below the tippie floor, and supported entirely independent of the tippie structure. But the remarkable part of the installation is the scales themselves.

Railroad-track scales of steel construction, except the deck, are standard practice with railroads, and not so rare among coal mines, but Delagua has four 74-foot, 100-ton, track scales of all-steel construction, including the deck, and on a 2-per-cent. grade. This was accomplished by the use of tapered built-up girders, 18 inches high at the low end and 36 at the other; on each girder rests an oak cushion, then the steel-



FIG. 3. TIPPLE, SOUTH SIDE OF OVENS

plate deck, and on it the rail, bolted through the deck and cushion to the top flange of the girder. Steel plates bolted to concrete form the coping, and steel plates loosely hinged cover the crack between the coping and the deck. Perforated-steel trap doors in the deck give ventilation and access to the parts of the scale beneath.

The tippie is entirely of wood; sills, posts, and caps being 12 in. x 12 in., and bracing 4 in. x 12 in. under dumps and screens; otherwise, sills and posts 10 in. x 10 in., caps 10 in. x 12 in., and bracing 3 in. x 10 in., all securely bolted. Stringers under tracks carrying locomotives are 4 in. and 8 in. x 16 in., and otherwise 4 in. and 6 in. x 12 in. These stringer sizes are determined by 15-ton electric locomotives on 16- and 18-foot spans. Material is almost entirely Oregon fir, and posts are all full length from sill to main cap.

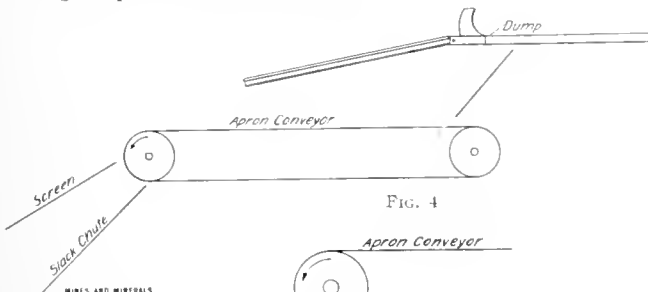

FIG. 4

MINES AND MINERALS

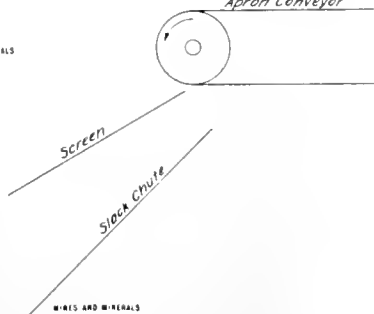

FIG. 5

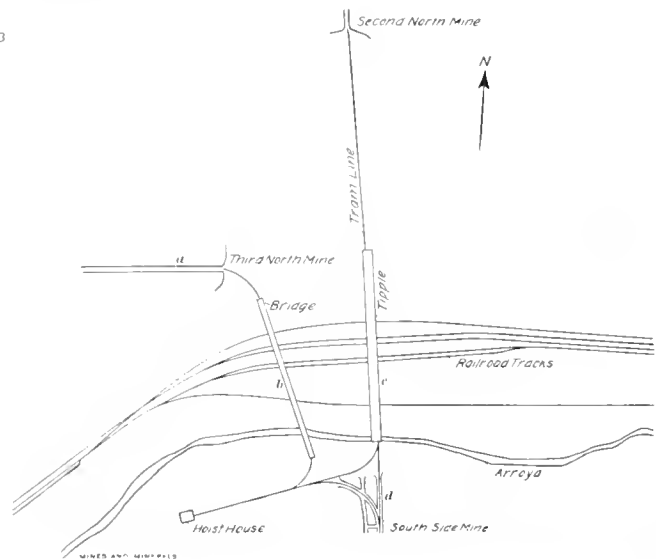

FIG. 6. MAP OF SURFACE ARRANGEMENTS AT DELAGUA

The timber bents are carried by square concrete piers immediately under each post, and which extend not less than 30 inches above the present ground level, so that in spite of the natural filling up which almost invariably takes place around a coal tippie, the sills are safe from rotting for some time.

The capacity of the tippie at present is determined by the speed of the car hauls, and is about 1,700 tons per day for each side, or 3,800 tons for the tippie. Should it become necessary, however, the car hauls could be speeded up so that the limiting factor would be the dumps, whose capacity is easily 2,000 tons each.

A 15-horsepower motor on each side is belted to a main countershaft for that side on which all clutches are mounted. This countershaft is belted to the car hauls and connected by rope drive to the feeder conveyer. These two countershafts, which run at the same speed, are connected by a rope drive so arranged as to drive from either end, so that in case of motor trouble on either side, merely throwing two jaw clutches will bring power from the other; one 15-horsepower motor will readily handle all the machinery on the whole tippie.

At about 30-foot centers on each side the floor projects in a 4-foot square, carrying a water barrel; and on the same centers between the barrels are 2 ft. \times 6 ft. projections carrying boxes, with lids, full of sand, which is a better medium for fighting fires of electric origin than water. A layer of sand is also kept on the floor between the rails and for 18 inches on either side of the track this catches all oil drippings and is an effective protection for the floor.

Goodman, Westinghouse, and Jeffrey electric locomotives of 250-volts direct current are used, and in weights of from 4 to 15 tons. There are two rack-rail locomotives in use on the south side. One and one-quarter inch cast-steel haulage rope is used on the hoisting engine, which is a single drum, two-motor hoist, with 20,000 pounds rope pull capacity.

When the plant burned in 1910 the mine was taking some power from the Southern Colorado Power Co. and now takes all its power from that company's successor, the Federal Light and Power Co. The substation for stepping this power down from 22,000 to 2,300 volts is a concrete and steel fireproof structure, which while slightly damaged by falling stacks, was not seriously injured by the fire, and was a powerful factor in restoring operations so soon after.

The coal worked is known as the Delagua seam, is from 6 to 7 feet thick, and is mined by room and pillar in a modified panel system.

采 采

Trade Notices

Tippie, McGregor Coal Co.—The Link-Belt Co. has contracted for building a coal tippie for the McGregor Coal Co., which will be erected on Rums Creek, Logan County, W. Va. The president of the company is John Laing, who is also chief mine inspector for the state of West Virginia. The tippie will be one of the largest in that section of the country and will be built of structural steel, sheathed and roofed with corrugated iron, and contain car feeders, trip makers, picking bands, a double set of "Link-Belt" shaking screens, slack conveyers, and conveyers for taking the slack coal to the boiler house. The Link-Belt Co. will design, furnish, and erect the entire equipment complete.

H. W. Johns-Manville Co.'s New Offices.—Owing to increasing business in Louisville, Ky., the H. W. Johns-Manville Co. have moved their offices from the Lincoln Savings Bank Building to 205 Paul Jones Building. The office will be in charge of Mr. J. R. Chowning, who for a considerable time traveled in that section from the Milwaukee office. A complete line of J-M asbestos and magnesia products, electrical supplies, packings, pipe coverings, roofings, etc., will be handled from this office. On January 24, the Pittsburg branch of the H. W. Johns-Manville Co. was moved and now occupies the entire eight-story stone, reinforced-concrete and

steel building at the northeast corner of Wood Street and First Avenue, which has been leased by them for a term of years. This building has a total gross floor space of approximately 23,808 square feet, and is one of the most substantial structures in the down-town section of Pittsburg.

Goulds Mfg. Co. House Warming.—The completion of the three new buildings of the Goulds Mfg. Co., Seneca Falls, N. Y., was celebrated Friday evening, January 19, by a grand ball, given by the Goulds Mutual Benefit Association. The two new machine shops used for the ball, were handsomely decorated and equipped with special illumination for the occasion. One was used for dancing and the other was fitted up for the dining hall and cloak room. It also contained card tables for those who did not care to dance. From 8 until 10 p. m. a concert was given by a band from Syracuse, N. Y., after which the floor was cleared for dancing. The new hard maple floor had an excellent surface and there was plenty of room for all, although over 2,000 were present. Supper was served by a caterer and every one reported a most enjoyable time. The association, which is an organization for the benefit of sick members, made a handsome profit from the proceeds.

Thermometers.—Exact knowledge of temperatures of air at mines is important, both in regard to ventilation and in case of fires underground, while economies are often possible from accurate determination of temperatures of boiler feedwater, flue gases, and solutions used in metallurgical processes. To obtain this knowledge requires instruments, not only exact in their indications, but suited in shape and construction to the special uses to which they are to be put. A recent catalog of Schaeffer & Budenberg Mfg. Co., of Brooklyn, N. Y., illustrates and describes thermometers of their manufacture suited to use in nearly a hundred different industries, and capable of measuring temperatures up to 1,000° F. It also includes recording and dial thermometers. Besides these they make indicating and recording instruments for measuring pressure, temperature, draft, power, and speed, including pressure and vacuum gauges, electrical pyrometers, dynamometers, tachometers, counters, and engine registers, indicators for steam engines, and calorimeters. The catalog will be sent on application.

"Advance in Air Compression."—Owing to the numerous inquiries that have been received by MINES AND MINERALS relative to the manufacture of the Rogler-Hoerbiger valve, described in the January issue of MINES AND MINERALS in an article entitled "An Advance in Air Compression," it is stated that the manufacturers of this valve are the Lilleshall Co., Ltd., Oakengates, Shropshire, England.

The Watt Mining Car Wheel Co., announce that the arrangement by which they were represented in Chicago by Ira E. Stevens and the Stevens Mine Fan Co., has been discontinued, and that all business will hereafter be handled direct from the office of the Watt Mining Car Wheel Co., Barnesville, Ohio. Patrons are requested to make use of the services of the expert car men connected with the company for the purpose of designing new equipment or changing old to meet present mining conditions.

采 采

Coke for Foundry Purposes

For foundry purposes coke should be strong and hard, dense, of good cell structure, as free as possible from ash, should contain only a little sulphur, and should be uniform in texture. The best coke should not contain more than .7 to .8 per cent. of sulphur; if it contains more than 1.3 per cent. it is unsuitable for use in the cupola. High carbon coke with little ash and low sulphur, with suitable physical characteristics to enable rapid and complete burning in the smallest space, will insure the best results from the cupola by the rapid melting of clean, hot metal with the lowest possible fuel consumption. Coke should be kept dry under cover, for water introduced into the cupola means waste of heat. If the cupola is properly designed and the air supply properly regulated the coke cannot be too dry.

Scientific Coal Mine Management

Three Devices by Which Accurate Knowledge of Working Conditions Can Be Had Daily

By Sim* and W. H. Reynolds

In the following article it is not intended to imply that the ideas incorporated are in every case wholly original. Neither, perhaps, are they explanatory of the best possible methods extant by which the object sought is attained; but they are in each instance

of every idle room or heading which is in a bad (unworkable) condition. A blue-headed pin is inserted at the point on the chalk map designating the face of every workable room or heading which is temporarily idle. All places on the board which are free of pins of any sort are known instantly as "working."

Changes are made daily in the location of these pins by the fire bosses or foremen, because a place that was "vacant" or "in bad order" yesterday might be in good working condition, or occupied by workmen, today. Likewise a room or entry which yesterday was in good shape or working, might be idle or impossible today by the reason of its having suddenly developed a horseback, an enlargement of a clay vein, or the advent of some ugly roof. Being thus kept up from day to day, a glance at this board shows the mine foreman, the superintendent, or the manager, the actual condition of things, without the necessity of a trip of inspection over many miles of workings. The mine foreman can see at a glance those sections that require his special attention, and this tends toward efficiency on his part, at the same time giving that needed conservation of managerial energy essential in keeping a large plant up to the required standard.

For any foreman to retain in his memory an acute working remembrance of so vast an underground system without some such concrete yet accurate "picture" thereof, in addition to the thousand other matters daily and hourly demanding his attention, becomes at once a physical impossibility. For this reason alone, in the great possibilities for good to the foreman, his men and his employers, the worth of such an arrangement is incalculable, and may be the means ultimately of bringing a mine to that plane of safety and economy which precludes disaster—either physical or financial.

At the Marianna mines the writer had the blackboard photographed and prints made postcard size. One of these "handy maps" is carried by every mine officer among his other requisites of service while underground. In this pocket-size replica of the blackboard map each official has an accurate, handy, and up-to-the-minute mine map. New copies can easily be taken after each weekly change is made on the blackboard. As the only available substitute for such a map, it is common practice with some mine officials to carry around a bulky mine blueprint, unfolding it at intervals to become familiar with workings perhaps totally new to them. A photographic card answers this particular purpose and is more convenient to handle, especially in a windy airway.

"Trouble Sheet."—Another idea born of acute necessity for a better system than that obtaining in the management of some mines,

Check	Working Place	Reason given for leaving mine	Time
350	2 South 4 Butt	No coal. Place not cut	8 am
275	Buddy to above	" " Same reason	8 "
69	4 Left R. Face	Entryman. Water in place. Came broke	10 "
47	R Face Entry	Has some business at home	10.35
360	2 Butt 1 South	Place finished. Got new place tomorrow	11 00
435	3 Butt 1 Blanche	Boss sent him home. Didn't cut up, boots	12 25
66	2 Butt R Face	Fall in room. Wait for timbermen	2 PM
460	Main Entryman	Too much sick. Big head. Yesterday drunk	2.35
461	Buddy of above	Little bit sick too	" " 2.35
260	R Face Aircourse	Sprained his back. Going to doctor	2.40
330	2 Butt 1 South	Not enough cars	3.05
331	Buddy of above	Same as above	3.05
047	1 Raise Face Entry	Cutter. Machine Broken. Work tonight	3.10
0047	Buddy	Scraper. Come back tonight	3.10

FIG. 1. TROUBLE SHEET

original, in so far as the writer has never hitherto seen them put into practice nor publicly explained.

Although every mine may not be so large, nor the necessity so urgent, as to call for the use of these and many other lesser and larger "schemes" which have helped to make things run more smoothly for the mine manager of one of the largest and most excellently equipped plants in the United States, yet from an intimate knowledge of other mines not so extensive the fact is presupposed that there is hardly a plant anywhere but the need for some such "ingenious" method of getting around things exists at some time or other, and no matter how large or small the plant these ideas may prove of service if applied in the same way.

Blackboard and Miniature Mine Map.—Idea number one is simply a chalk sketch of the standard mine map drawn on a blackboard situated in the underground manager's office in the Rachel shaft, Marianna, Pa., and is about 8 feet by 12 feet in dimensions. The blackboard map is an accurate copy of the regular mine map blueprint, excepting only the station numbers, surface marks, and other things not essential to the particular purpose for which this chalk sketch is intended. It does, however, show all entries, air-courses, traveling ways, etc., on a scale approximating 50 feet to the inch. As weekly measurements are taken throughout the mine, the blackboard map is changed to keep it up to date at all times.

The idea of an arrangement of this kind originated in the necessity of knowing at a glance, at any moment, the actual condition of the mine, in so far as concerns the working places. This is accomplished in the following manner:

On this board, which is constructed of the softest pine, are used two different colored pins, commonly called "push pins." A red-headed pin is inserted at that point of the chalk map designating the present face

Time	AM 8	AM 9	AM 10	AM 11	AM 12	PM 1	PM 2	PM 3	PM 4	PM 5	Remarks
2 nd	35	79	120	170	200	200	265	350	410		Short of coal
3 rd	50	50	150	185	210	210	271	340	375		motor in shop 1 hour for repairs
4 th	45	60	130	170	200	200	285	350	410		no delays
5 th	60	110	160	206	235	235	315	305	430		" "
6 th	65	120	170	215	250	250	330	390	450		" "
7 th	35	115	150	175	210	210	290	330	380		Short of coal
9 th	43	76	110	180	216	216	276	310	403		
10 th	54	89	105	150	200	200	240	290	350		Broke down Shop 70 minutes
11 th	46	75	83	120	190	190	220	293	374		Short of coal
12 th	53	86	115	167	193	193	213	280	370		Hot. motor Bars. This must be remedied immediately. Must be kept above 400 mark.
13 th	64	93	130	170	211	211	227	286	360		
14 th	47	87	125	190	220	220	279	350	390		S. C. R.
16 th	53	78	110	178	215	215	280	310	370		
17 th	47	63	100	150	190	190	250	319	378		
18 th	60	100	135	178	215	215	260	300	340		wrecked 50 minutes

FIG. 2. RECORD SHEET OF MOTOR PERFORMANCE

*Underground Manager of the Marianna Mines, Pittsburg-Buffalo Coal Co., Marianna, Pa.

is a daily record similar to that illustrated in Fig. 1. At the Marianna mine we call this bit of system "The Trouble Sheet." This graphic system of keeping checks on troubles is possible of accomplishment only where the men enter and leave the mine by one way. At Marianna this record is kept by a timekeeper whose office is so located that he sees every man who leaves the mine outside of regular hours. It could, however, be quite as easily kept at a smaller mine by the cager, or some other capable employe whose services keep him near or at the exit.

This "Trouble Sheet" is turned in to the chief foreman when possible, otherwise to the superintendent or general manager, at the end of each shift, or perhaps the next morning.

On it is recorded the check number of any employe leaving the mine during working hours, his room or entry number, and, if a room man, then the entry in which he works; with this is a brief explanation as to why he left the mine earlier than the regular quitting time. One man, for instance, going home at 8 o'clock, gives as his reason: "Place full of water." Two or three others perhaps come out from places near together and give as their reason for going home: "No cars." Singly or collectively we learn of some from another section whose day is spoiled because "Their places have not been cut for two days."

A glance at this sheet at night readily conveys to the head official the information that some of these men, and perhaps all, might have been at work if certain others employed by the company, probably as day men, had not been lax in their duty. The water, for instance, should not have been left standing in the room or entry, and a little extra attention to cutting and hauling in other sections would have obviated the necessity of other men going home. It occurs to the manager that some one is responsible for these conditions, and with the concrete facts of "The Trouble Sheet" standing before him he has at his finger end the means of readily placing the responsibility.

Where men are allowed to come and go unnoticed and unrecorded it is not alone the loss of their services and the consequent diminishment of output which affect the company's books, but the more vital fact that an inefficient day man may continue drawing unearned pay without being found out. Nor, with this plan, may the blame for certain bad conditions be shifted onto the innocent, as is sometimes the case. The fact that "The Trouble Sheet" bears no indictment from a certain employe's section day after day or week after week, and yet again from another part is constantly recurring iteration of "trouble," generally implies inefficiency somewhere, or if not that, then at least the suggestion that an investigation is needed that will straighten out matters to the better satisfaction of all concerned.

Records of Motor Performances.—Another idea in connection with scientific mine management which has been found of much value is keeping records of motor performances. These are looked after by the switchman, and kept on file, for comparison, at his shanty at the shaft bottom. In the Marianna mine at this point several express motors deliver the loads collected in their various sections, after they have been placed at the different stations by the gathering motors. At the end of each working hour the switchman records on a sheet, Fig. 2, the number of loads brought to the shaft by each motor, which is totalled at the end of the shift, and grand totalled at the month's end. By instant comparison either the motorman, or any other man interested, whether he be general manager or any other officer in the mine, can at any time find out all he desires to know as to the work being done by any given motor or motorman, whether it's "comin' or goin'," as a motor boss explained recently. Reduced to purer if not more practical English this meant of course that he could on a minute's notice find out whether any one of his men were falling below standard; whether a certain motor had to its credit during the hours of 7 to 12 on November 5 as much tonnage delivered at the shaft bottom as it had during the same hours on the same day a month previous.

The result of this method concerning motor runs to a specific spot, while indefinite and not very easily translatable to paper, has

nevertheless proved valuable in at least one mine. This constant availability of service records of men working by the day serves as an automatic stimulant to the men directly identified therewith. The records serve as a silent, unsalaried, yet valuable assistant to the motor boss, and in case there is in his force a persistent laggard, it enables him to place his finger on the one at fault, and get rid of him if necessary. And this matter of instant identification of the "sore spot" is, in all three of the methods of management mentioned in this article, perhaps the most valuable item resulting therefrom. In any large mine employing a great number of men and much diversity of labor, it becomes a hard matter, without some such automatic aid as herein detailed, to readily find just where the fault lies. And any means which tends to lessen the inevitable confusion of extensive yet more or less unsystematic management should be of much worth to the employer and the employes as well, since the latter in the end are bound to profit by it as much as the former.

采 采

Mining Society Notices

The fifteenth General Annual Meeting of the Canadian Mining Institute will be held at the King Edward Hotel, Toronto, Ontario, beginning Wednesday, March 6, and including March 8, 1912. It was the original intention to hold this meeting in Ottawa, but the subcommittee of the council reluctantly concluded to reconsider their decision. In explanation of its action in this regard, the committee desires to state that although definite assurance had been given that adequate hotel accommodation for members and others attending the meeting would be provided at Ottawa, the conditions are such that the Committee do not feel justified in jeopardizing the success of the meeting by dependence on these assurances, particularly in view of the large number of applications for reservations already received. For this meeting 34 papers have been announced and others have been promised. There are five papers on gold, three on silver, five on coal, one on platinum, one on petroleum, one on asbestos, five on geology, two on smelting, one on safety appliances, one on company law, one on manganese, one on iron; other subjects not announced.

The West Virginia Coal Mining Institute is proposing some radical amendments to the constitution of that society. It is proposed to amend Article V, Section I, so that but one meeting shall be held annually, between September 1 and October 31. In order to keep the interest alive in the Institute, between the meetings, it has been suggested that the president appoint various members to prepare papers, have them printed in pamphlet form and sent out to all members at intervals of one every two months. The members could then prepare their discussion or questions in written form, in a logical manner, and send them to the president, who in turn could turn them over to the writer of the paper for his remarks, or the writer could answer the questions at the next meeting. This plan would do away with the actual reading of the papers at the meetings and would leave more time for the discussion of the papers, which, after all, is one of the most important and interesting features of the meetings.

Mining Society, University of Illinois, held the regular semi-annual election of officers recently. The following were elected: President, Leonard V. Newton; first vice-president, A. L. Voight; second vice-president, L. R. Bell; secretary, L. Swett; treasurer, W. S. Middleton. The following men gave talks: Mr. Andros, of the United States Bureau of Mines, on "Placer Mining"; Mr. Rossbach on the "History of Coal"; Mr. Voight on the "Arrangement of Shaft Bottoms."

采 采

The mechanical efficiency of a ventilating equipment is the ratio of the actual horsepower output to the actual horsepower input. If, for example, the actual horsepower output is 31.5, and the actual horsepower input is 44.4; then, dividing the output by the input, $31.5 \div 44.4 = 71$ per cent. the mechanical efficiency of the equipment.

Standardization in Coal Washing

A Plea for Uniformity in Tests and Reports—Formulas for Accurate Comparison of Washery Work

By Geo. R. Delamater*

In reviewing the rather limited literature of the past 5 or 6 years upon the subject of coal washery tests and control, one is impressed by the fact that it has excited so little discussion on the part of those supposedly interested in the subject. This lack of discussion has led to such a divergence in the methods of making reports and to such a difference in the usage and meaning of terms commonly employed that it is, at present, practically impossible to tell from a report the exact results obtained at any particular washery, or to compare the efficiency of one plant with another. The average report, while describing with more or less fullness the machinery in use at the plant under consideration, and likewise giving sufficient data to show that a washed product of satisfactory quality is being made, is almost invariably silent upon such important questions as the amount of good coal carried away in the refuse, the amount of refuse unnecessarily present in the washed coal, and, consequently, upon the efficiency of the plant as a whole.

In the present paper, the writer desires to call attention to certain phases of the coal-washing problem and to present some new data, formulas, and the like, in the hope that a general discussion of the subject through the columns of MINES AND MINERALS will lead to the ultimate adoption not only of a uniform method of determining washery efficiency, but also of a uniform type of report, to the end that coal washing may cease to be the haphazard branch of engineering it too long has been.

The specific gravity bath, which is more commonly known as the "float-and-sink" method of separation, has been almost universally accepted as the only way in which all free pieces of impurities may positively be removed from the coal. It therefore may be truly considered as the standard method of separation, always having an efficiency of 100 per cent., and should be used as the basis of all calculations of plant or washing-machine efficiencies. It is unfortunate this method is not commercially adaptable. It is stated that a machine has recently been constructed along these lines using a solution of the relatively cheap calcium chloride for the bath. Many coals, however, require for their separation a bath having a greater density than 1.43, which is the maximum obtainable with cold solutions of calcium chloride. If heated, the density may be increased by the addition of more of the chloride salt, but crystallization takes place upon cooling, to the detriment of the product. Zinc chloride, twice as costly as the corresponding calcium chloride salt, may be used and will yield solutions as high as 2.00 in density when cold. However, either salt is expensive, and as there must be a constant replacement of the solution carried away in both the washed coal and the refuse, the cost of washing by this method, perfect as it is, cannot be held as low as in properly designed systems where water alone is employed.

The methods and apparatus used in making float-and-sink tests were discussed at length by the writer in the issues of this journal for August and September, 1907, and for August, 1909. For the benefit of those who are not familiar with the use of the float-and-sink tests and for the purpose of showing the reason for some slight changes the writer has since made in regard to their use, the following brief outline of such tests is submitted:

"Preliminary" float tests are made on a coal when it is desired to determine the feasibility of washing it. These tests show what percentage of refuse must be removed to obtain a washed product of the desired quality, and also show the fineness to which the coal must be crushed to give the best results. Briefly stated, the preliminary, or raw coal tests, are made as follows:

Coking Coal Propositions.—The coal is crushed to a maximum size of usually $1\frac{1}{4}$ or $1\frac{1}{2}$ inches. Generally $1\frac{1}{4}$ -inch slack is used in the manufacture of coke. A representative sample is properly

divided into, as a rule, six smaller samples. A series of six liquid baths is then prepared, the specific gravities or densities of which range from 1.35 to 1.60, or higher, depending on the coal to be tested. Into these baths, in the order of their density, are deposited the samples of coal above mentioned. The material remaining or floating on the surface of the bath is known as the "float," and corresponds with the washed coal of the washery, and that which settles to the bottom is known as "sink," and corresponds with the refuse or waste product of the washery. A smaller percentage of float will result on the 1.30 specific gravity bath than from any of those of greater density, and as the percentage of float is increased on each succeeding increase of bath specific gravity, so will the ash content of the float be increased. Therefore, a float from some one of the baths will show an ash content of the desired percentage, but it may be found that the percentage of sink (refuse) is high and that many pieces of sink have considerable pieces of coal adhering to them. Another sample of coal, crushed somewhat smaller, say to a maximum size of $\frac{3}{4}$ inch, is then divided into six smaller samples and the same procedure followed as before. Naturally more of the coal is broken free from the impurities and a lower percentage of sink will result from these tests. This operation is continued until it is determined just how fine the coal must be crushed to obtain the most satisfactory results.

As an illustration of the use of the preliminary float-and-sink tests, assume that it is desired to produce a coke containing 15 per cent. ash. Roughly, 1 per cent. of ash in the coal will result in 1.5 per cent. ash in the coke. Therefore, to produce a 15-per-cent. ash coke, the coal from which it is made must not analyze more than 10 per cent. ash. Should it be found that a bath of 1.45 specific gravity yields, say 90 per cent. float (washed coal) with an ash content of the desired 10 per cent., and that a less density diminishes the yield of float, or a greater one increases the percentage of ash, then 1.45 is the proper specific gravity for the bath to be used for this particular coal unless the tests on the coal crushed to a greater degree of fineness prove otherwise, though the suitable specific gravity seldom changes in these tests, the percentages of float and sink only being affected.

Domestic Coal Propositions.—If the coal tested is intended for domestic use, the question of crushing does not enter into the problem. The only consideration is the amount of possible improvement as indicated by these tests. As the size of the coal is, of course, fixed, one full set of six tests will be found ample.

Throughout the balance of this paper, the specific gravity of the bath thus found suitable for the raw coal tested will be referred to as the "permissible bath" or "permissible specific gravity."

Now, from what has been presented above, we find that a properly operating washery, or one operating at 100 per cent. efficiency would be a plant the washed-coal product of which, when tested on the permissible bath, would show absolutely no sink, and likewise, the refuse product tested on the permissible bath would show absolutely no float. We therefore have another use of the float-and-sink test in checking up the work done by the operating plant for, if any sink results from the washed-coal test, this sink properly belongs in the refuse, and, likewise, if any float results from the refuse test, this float properly belongs with the washed coal. This is true regardless of the analysis of either float or sink, as the same specific gravity has been used in all tests. This will be treated more fully under the subject of "Good Coal."

From the above the following formulas, which hold true whether weights or percentages are used, may be given here:

For a perfectly working plant,

$$(A) \text{ Raw Coal} = \text{Pure Washed Coal} + \text{Pure Refuse.}$$

As perfection is not obtainable we will generally have,

$$(B) \text{ Raw Coal} = \left\{ \begin{array}{c} \text{Pure Washed Coal} \\ + \\ \text{Refuse in Washed Coal} \end{array} \right\} + \left\{ \begin{array}{c} \text{Pure Refuse} \\ + \\ \text{Coal in Refuse} \end{array} \right\}$$

When used in connection with float-and-sink tests, (B) becomes,

$$(C) \text{ Raw Coal} = \left\{ \begin{array}{c} \text{Washed Coal Float} \\ + \\ \text{Washed Coal Sink} \end{array} \right\} + \left\{ \begin{array}{c} \text{Refuse Sink} \\ + \\ \text{Refuse Float} \end{array} \right\}$$

* Consulting Engineer, Denver, Colo.

The more nearly (B) and (C) approach (A) by a decrease in the amount of refuse in the washed coal (washed coal sink), and in the coal in the refuse (refuse coal), the more nearly perfect is the working of the plant.

As it is apparent that changes in the density of the testing bath must cause variations in both the amount and the composition of the float and sink, it follows that:

1. In investigations at any given plant the density of the solution should be the same in making the raw coal, washed coal, and refuse tests.

Only when the character of the coal changes, will an alteration in the density of the testing solution be necessary. An increase in the amount of heavy slate or sandstone in the raw coal demands no such alteration, but should a gradual change take place in the character of the bone coal, it may become necessary to use a solution of a different density from that of the one upon which the plant was designed. However, in any particular series of tests the density of the bath should be the same throughout.

Engineers vary in the meaning placed upon the term "good coal," and particularly upon that of "good coal lost in the refuse." Until very recently the writer held to the generally accepted view that "good coal" was material of the same composition as the washed coal the plant is designed to produce. Recently, Mr. J. B. Morrow, superintendent of ovens and washeries for the Stag Cañon Fuel Co., at Dawson, N. Mex., has advanced a different view, which the writer now accepts as being more in accordance with the results obtained in actual practice. In Mr. Morrow's opinion "good coal" is anything that floats on the permissible bath, regardless of its mineralogical composition or ash content. Assume that the raw-coal tests have demonstrated the possibility of a washed coal containing 10 per cent. ash. The washed-coal tests show no sink, but the refuse tests show a certain amount of float, some pieces of which analyze as high as 20 and some as low as 2 per cent. in ash. The washed coal and refuse floats are now mixed. It is evident that the joint product cannot show more than 10 per cent. ash, as we now have the same float as was obtained on the permissible bath test of the raw coal. It is also evident that this refuse float must be "good coal" and is lost with the refuse. Had the washed-coal tests shown a certain percentage of sink, then it might be possible that, were the refuse float added to the washed coal, the percentage of ash in the combined coal would be higher than the 10 per cent. intended for it, caused, of course, by the presence of the sink. An attempt should then be made to eliminate the sink from the washed coal by readjustment of the washing machines.

It is not a general custom among engineers to determine the amount of refuse matter in the washed coal by the float-and-sink method. There also exists a difference of opinion regarding how the percentage of coal loss in the refuse should be calculated. Many calculate the loss of good coal as a percentage of the raw coal. As an example, assume a certain plant is producing 15 per cent. refuse and 85 per cent. washed coal. Also that the permissible bath test of the refuse gave a float of 10 per cent. To calculate the loss of coal by the above method the loss would be,

$$\frac{10 \text{ per cent. (refuse float)} \times 15 \text{ per cent. (refuse)}}{100 \text{ per cent. (raw coal)}} = .015, \text{ or } 1.5 \text{ per cent.}$$

Mr. Morrow, quoted above, holds that "good coal" is only that material floated by the permissible bath test of the raw coal and that, to calculate or express the "good coal" loss as a percentage of the raw coal is a misnomer, and instead it should be calculated and expressed as a percentage of the "good coal" carried by the raw coal. Therefore, in calculating the loss in the above example, one must first refer back to the permissible bath test of the raw coal and we will assume the float in this test amounted to 90 per cent. The calculation would therefore be:

$$1. \text{ Coal loss} = \frac{10 \text{ per cent. (refuse float)} \times 15 \text{ per cent. (refuse)}}{90 \text{ per cent. (permissible float or "good coal")}} = .0167 = 1.7 \text{ per cent.}$$

From this follows:

2. The percentage of loss of good coal in the refuse should be

based upon the percentage of float obtained in the permissible raw, coal float test.

The following formula (D) is submitted for properly determining the percentage of good coal lost in the refuse:

Let,

X = per cent. of good coal lost in the refuse;

b = per cent. of raw-coal float (from permissible bath);

i = per cent. of refuse produced by the plant;

j = per cent. of refuse float (from permissible bath);

M = j × i = per cent. of float coal in the refuse in terms of the raw coal.

Then we will have,

$$(D) \quad X = \frac{j \cdot i}{b} = \frac{M}{b}$$

Plant Efficiencies.—As the writer has never seen this subject discussed in print, he presents the following suggestions with considerable hesitancy. When applied to machinery, efficiency is taken to mean the ratio of the useful to the total work performed by the machine. In coal washing, efficiency may be considered as the ratio existing between the actual and the possible separation effected by the machine or plant.

In every plant there is both a washed coal and a refuse efficiency to be considered. The writer desires to suggest the following method of calculating these efficiencies: From formulas (A), (B), and (C) we determined that a perfectly operating plant must produce a washed coal product in which no sink may be obtained by the permissible bath test, and likewise a refuse product from which no float will result from such test. Therefore, if the float test of the washed coal gives 10 per cent. sink, the washed coal efficiency would be 100 - 10 = 90 per cent. Likewise, if the float test of the refuse gives 15 per cent. float, the refuse efficiency would be 100 - 15 = 85 per cent. To state these as formulas, (E) (F) we have:

Let, W = washed coal efficiency;

R = refuse efficiency;

g = per cent. of washed coal sink;

j = per cent. of refuse float.

Then,

$$(E) \quad W = 100 - g, \text{ and } (F) \quad R = 100 - j.$$

In suggesting the above formulas for calculating washed coal and refuse efficiencies, the writer realizes that the primary object of all coal washing is the attainment of a washed product suitable for the requirements of the proposition in hand, as for instance, to wash a 20-per-cent ash raw coal and produce a washed coal of 10 per cent. ash to be used in the manufacture of coke, of which the ash must not exceed 15 per cent. Many may assume that if two machines working upon the same raw material, each produce therefrom a washed coal analyzing 10 per cent. ash, they have equal efficiencies. Such is far from being true, as a little reflection will show.

Take the case of a washery treating 100 tons of raw coal daily the average ash content of which is 20 per cent. Float-and-sink tests show that it is possible to produce from this, by washing, 80 tons, or 80 per cent. washed coal analyzing 10 per cent. ash; and 20 tons, or 20 per cent., refuse analyzing 60 per cent. ash. Other float tests show that this 80 tons of washed coal is made up of:

	Per Cent. Ash
60 tons (75 per cent.) of coal analyzing 5 per cent. ash. In terms of total washed coal = 5 per cent. (ash) × 75 per cent. (coal).....	= 3.75
20 tons (25 per cent.) of bone coal analyzing 25 per cent. ash. In terms of total washed coal = 25 per cent. (ash) × 25 per cent. (coal).....	= 6.25
Per cent. of ash in 80 tons of washed coal.....	= 10.00

The washed coal production having fallen off, though the same tonnage of raw coal is washed, float tests are made and the washed coal is found to contain:

	Per Cent. Ash
60 tons (90.91 per cent.) of coal analyzing 5 per cent. ash. In terms of total washed coal = 5 per cent. (ash) × 90.91 per cent. (coal).....	= 4.5455
6 tons (9.09 per cent.) of refuse matter analyzing 60 per cent. ash. In terms of total washed coal = 60 per cent. (ash) × 9.09 per cent. (coal).....	= 5.4545
Per cent. of ash in 66 tons of washed coal.....	= 10.0000

Thus, while in each case the washed coal contains the required 10 per cent. of ash, 14 tons more washed coal are produced in the first case than in the other. If the raw coal delivered to the washery is worth \$1 per ton, the cost of the washed coal (neglecting operating charges) in the two cases is, respectively, $100 \div 80$ and $100 \div 66$, or \$1.25 and \$1.52 per ton. In the second case, aside from the increased cost in the washed coal of 27 cents a ton, there is a further charge to be made for the additional 14 tons of refuse that must be handled. At the very low cost of 2 cents a ton this will amount to 28 cents for each 100 tons of raw coal handled by the plant. Also, the presence of the bone coal in the refuse pile may cause trouble by reason of fires started through spontaneous combustion usually caused by the presence of more or less iron pyrites therein, and slate in the washed coal, being infusible, will determine lines of easy breakage in the coke.

The total efficiency of a plant, or of individual machines, may now be considered to be the average of the washed coal and refuse efficiencies, or

$$(G) \text{ Total efficiency } T = \frac{W+R}{2}$$

The formulas given *A*, *B*, *C*, *D*, *E*, and *F* (but not *G*), while enabling us to compare the efficiencies of two or more machines or plants working upon the same coal, do not permit us to decide whether a machine operating under markedly different conditions will prove satisfactory at our own plant. That is, these formulas are more special than general in their application.

As an illustration, we will assume that a certain plant *A*, operating in the bituminous coal fields of Pennsylvania, is washing a coal of which the permissible raw-coal float test gave a possible washed-coal product of 85 per cent., together with 15 per cent. refuse. Another plant, *B*, is operating in the anthracite coal fields of the same state, but under very dissimilar conditions, say at a culm bank, the permissible raw-coal float test of which gave a possible washed-coal product of but 50 per cent., and a refuse product of 50 per cent. We will assume that the refuse float tests show that 20 per cent. of the refuse in both cases is good coal. Special note having been made of this, study closely the results of our efficiency figures shown in the following comparative table of the two plants:

	Plant A Per Cent.	Plant B Per Cent.
Washed coal (actual production).....	83.00	45.00
Refuse (actual production).....	17.00	55.00
Raw-coal float.....	85.00	50.00
Raw-coal sink.....	15.00	50.00
Washed-coal float.....	98.31	86.70
Washed-coal sink.....	1.69	13.30
Refuse float.....	20.00	20.00
Refuse sink.....	80.00	80.00
Loss of good coal in the refuse.....	4.00	13.75
Washed coal efficiency.....	98.00	86.70
Refuse efficiency.....	80.00	80.00
Total efficiency.....	89.00	83.35

From the above we find the following:

To compare the work done at the two plants by means of the data showing the loss of good coal, we find plant *A* accomplished over three times better results than plant *B*, yet the percentage of refuse in each case, which was good coal, was identically the same. Obviously, this is an unfair comparison. The percentage of refuse float in both cases is the same, and for this reason some may claim this should be used as the comparative figure, yet again we have a difference in the percentages of washed-coal sink, and this most certainly should be considered. The refuse efficiencies agree, but again the washed-coal efficiencies do not.

The writer has gone into this in detail to show the confusion arising when an attempt is made to compare the merits of two different machines working upon two different coals. Formula (*D*) is most serviceable in comparing the performances of different machines or plants working under the same or essentially the same conditions, but fails absolutely in such cases as the one used for illustration. The writer is rather inclined to the opinion that the

total efficiency as herein determined is the correct method to be used in the comparison of all plants, whether working upon like coal or not. My reason is that the nearer both the washed coal and refuse efficiencies approach 100 per cent. the nearer will the total efficiency be to 100 per cent. Also, and what is more important, the higher the refuse efficiency, the lower will be the coal loss. To make this more clear, suppose the refuse is pure. In such a case the refuse efficiency is 100 per cent. and the coal loss must be zero. If the washed-coal efficiency is 90 per cent., the total efficiency is 95 per cent. Were the washed-coal efficiency 100 per cent., then the total efficiency would likewise be 100 per cent. If what has been written herein has been closely followed it will be seen that all of the efficiencies and other data given are based upon the fact that the washed-coal product has an ash content within the limits of the proposition in hand, so it cannot be said that the only feature of washing worthy of attention is the ash content of the washed product, for the total efficiency is most certainly an item worthy of careful consideration. In the example given of plants *A* and *B* it appears to the writer that the total efficiencies given, 89 per cent. for plant *A* and 83.35 per cent. for plant *B*, show very conclusively that plant *A* was doing a better total work than plant *B*. This is sustained by all the data given, for it will be noted that both plants are producing less washed coal than has been shown by the permissible raw-coal float test it is possible to obtain. In fact, the only advantage plant *A* has is in the washed-coal efficiency and in loss of coal.

As some machines will give better results when operating upon a coarse than upon a fine coal, and vice versa, there is little doubt that in comparing plant or machine efficiencies the size of the coal treated should be taken into consideration; that is, the size of coal washed should always be stated in the report. If this were done, we would then be able to determine the machine capable of operating successfully and with the highest efficiency under the greatest variation of coal sizes.

At some plants the raw coal is weighed; at probably all, the washed coal is weighed, but at few, if any, operations is the refuse actually weighed. The refuse is more generally estimated by counting the cars or buckets used per day in its removal and multiplying this number by a figure supposed to represent the weight of refuse it will carry. On account of the variation in the amount put in the bucket or car it is usually found that the weight of refuse thus obtained does not agree with the weight as obtained from other sources.

For this reason the following formulas may be of value, as by their use it is possible to determine, within very narrow limits, the percentages of both washed coal and refuse without having recourse to their actual weights. The tonnage may be figured if the weight of either the raw or washed coal is known. It is assumed that the three regular float-and-sink tests have been made upon the raw coal, washed coal, and refuse, respectively, and that the percentages of float and sink in each have been determined. We may here interpolate without explanation, as they are self-evident, two useful formulas of the same general nature as (*A*), (*B*), and (*C*). They are:

$$(H) \text{ Raw-coal sink} = \text{washed-coal sink} + \text{refuse sink.}$$

$$(I) \text{ Raw-coal float} = \text{washed-coal float} + \text{refuse float.}$$

As a number of formulas involving a long series of terms may now be deducted, it seems advisable, in order to prevent confusion, to here present in tabular form all the letters used and their respective meanings:

- a* = per cent. of raw coal used;
- b* = per cent. of raw-coal float;
- c* = per cent. of raw-coal sink;
- d* = per cent. of ash in raw coal;
- e* = per cent. of washed coal;
- f* = per cent. of washed-coal float;
- g* = per cent. of washed-coal sink;
- h* = per cent. of ash in washed coal;
- i* = per cent. of refuse;
- j* = per cent. of refuse float;
- k* = per cent. of refuse sink;
- l* = per cent. of ash in the refuse.

From a consideration of the formula (D), given before, we have:

$$(J) \quad j i + f e = b$$

$$(K) \quad k i + g e = c$$

Now, having the results of our float-and-sink tests, but not knowing the percentages of washed coal and refuse, we find that we have here two equations containing two unknown quantities, e and i , which may be solved for either value. Solving for i , we have

$$(L) \quad i = \frac{f c - g b}{f k - g j} = \frac{g}{f} \frac{c-b}{k-j}$$

By definition we have,

$$(M) \quad e = 100 - i$$

Or the value of e may be deduced from the above and,

$$(N) \quad e = \frac{k b - j c}{k f - j g} = \frac{j}{k} \frac{b-c}{f-g}$$

And similarly, from (M),

$$(O) \quad i = 100 - e.$$

Formula (L) cannot be used if the percentage of washed-coal sink is greater than the washed-coal float, nor can formula (N) be used if the refuse float is greater than the refuse sink. However, as such results occurring simultaneously would at once indicate an absolutely worthless washing, one or the other of these formulas will always be found applicable.

Aside from their adaptability to determine the percentages of washed coal and refuse produced, the above formulas enable us to check up all the steps of a series of float-and-sink tests, as well as all the analyses made in the course thereof.

Another serviceable formula taken from Richards' Ore Dressing and adapted to coal-washing tests is:

$$(P) \quad i = \frac{d-h}{l-h}$$

If the value of i obtained from this formula (P) does not agree with that obtained from (L), an error has been made. If the mistake has been in the float-and-sink tests some of the formulas from (A) to (I) will not balance. If they balance, some one of the three analyses must be wrong. If the analyses are found, upon being remade, to be correct, then the samples used for this purpose were not representative. If any of the formulas from (A) to (I) will not balance, then some one or all of the samples used in the float-and-sink tests are not representative.

Too much care cannot be exercised in sampling, which should be done by automatic samplers where possible, as a non-representative sample for either float-and-sink tests or for analyses renders all subsequent work worthless. Of the above formulas (A to I, L and P), the last has been employed for some time, and its use has often shown the existence of an error, without, however, affording a means of exactly locating it. Combining it with the others it is possible to check every item of a test, and nothing is left to guess-work. The writer believes that if reports upon coal-washing operations contained the proof of their accuracy by citing the above formulas, there would not be the opportunity for criticism of alleged results there is at present.

The following are inserted merely to complete the data and will be understood by the reader. Given the percentages of washed coal and refuse and the percentages of ash in the raw coal and washed coal, to determine the percentage of ash in the refuse, we have

$$(Q) \quad l = \frac{d-h e}{i}$$

If the percentages of washed coal and refuse are given, as well as the percentages of ash in the raw coal and the refuse, formula (Q) may be transposed to give the percentage of ash in the washed coal, and

$$(R) \quad h = \frac{d-l i}{e}$$

Using the formulas given above, together with those in the previously mentioned issues of MINES AND MINERALS, the writer wishes to recommend the following system of making reports upon coal-washing machines or plants.

There should be two separate forms or reports, one for preliminary investigations and another for machine or plant tests. The preliminary report is used in the original float-and-sink work undertaken to determine the size to which the coal should be crushed to give the most economic separation as well as the resultant amounts of washed coal and refuse. In the form submitted, spaces are provided for tests upon eight sizes of coal ranging from 1½ inches down to ⅜ inch. If nothing to the contrary is stated, it is to be understood that the coal treated contains all sizes from the largest to the smallest, under which it is listed. That is to say, if the test is recorded in the 1¼-inch column, the sample used was crushed so that while the largest pieces were of that size, all the finer material was present, none of it having been screened out.

If the test is made of a sized sample, say one which has passed through a 1¼-inch screen and over a ¾-inch or ½-inch screen, the observations should be entered in the column headed 1¼ inches, with a notation under the head of remarks to the effect that all the material finer than ¾-inch or ½-inch has been screened out. The percentage of fine coal screened out may also appear in the remarks column if it is desired to make a note of it. Space is also provided for recording tests with baths of six different specific gravities; a number ample for most purposes. The form for reporting upon operating plants is self-explanatory and needs no further comment.

It should be remembered that all analyses must be reduced to a dry basis, otherwise the results will be very seriously affected by differences in the percentages of moisture.

REPORT OF PRELIMINARY INVESTIGATION

Date _____

Owner of mine _____
 Address _____
 Name of mine _____
 Location _____
 Kind of coal _____
 Raw coal analysis: Moisture, _____%, V. M., _____%, Fixed Carbon, _____% Ash, _____%, Sul., _____%
 Tests made by _____
 Remarks _____

Specific Gravity of Solution	Item	Maximum Size of Coal							
		1½"	1¼"	1"	¾"	½"	⅜"	⅓"	⅛"
	Per cent. float								
	Per cent. sink								
	Float-coal analysis { Ash								
	{ Sulphur								
	Per cent. float								
	Per cent. sink								
	Float-coal analysis { Ash								
	{ Sulphur								
	Per cent. float								
	Per cent. sink								
	Float-coal analysis { Ash								
	{ Sulphur								
	Per cent. float								
	Per cent. sink								
	Float-coal analysis { Ash								
	{ Sulphur								

COAL WASHING REPORT

Date, _____

Owner of mine, _____
 Address, _____
 Name of mine, _____
 Location, _____
 Kind of coal, _____
 Size of coal as tested, _____
 Name of coal washing machine used, _____
 Screen area, _____ Bed depth, _____
 Strokes per minute, _____ Stroke length, _____
 Total raw coal washed, _____ Amount per hour, _____
 Water used per ton of raw coal washed, _____
 Duration of test, _____ Hours, _____ Minutes, _____
 Remarks, _____

Analyses

Moisture	Fixed Carbon	Volatile Matter	Ash	Sulphur
----------	--------------	-----------------	-----	---------

Raw coal.....				
Washed coal.....				
Refuse.....				

Washed coal efficiency, _____
 Refuse efficiency, _____
 Total efficiency, _____

Percentage of washed coal { By weight, _____
 { By float test formula, _____
 { By analysis formula, _____

Percentage of refuse { By weight, _____
 { By float test formula, _____
 { By analysis formula, _____

Loss of good coal in the refuse, _____
 Percentage of the refuse which is good coal, _____

Per cent. reduction { Ash, _____
 { Sulphur, _____

Per cent. removed { Ash, _____
 { Sulphur, _____

FLOAT-AND-SINK TESTS

Specific gravity of solution, _____
 Per cent. float from raw coal, _____
 Per cent. sink from raw coal, _____
 Per cent. float from washed coal, _____
 Per cent. sink from washed coal, _____
 Per cent. float from refuse, _____
 Per cent. sink from refuse, _____
 Per cent. ash in raw coal float, _____ % sulphur, _____ %
 Per cent. ash in raw coal sink, _____ % sulphur, _____ %



Civil Service Examinations

United States Civil Service Commission announces an examination on March 20-21 for the following positions: Ballistic engineer, salary, \$1,800; laboratory aid and engineer, salary, \$900; practical paper maker, salary \$1,000; assistant engineer in forest products, salary, \$1,200 to \$1,500; engineer in forest products, salary \$1,600 to \$2,500; assistant chemical engineer in forest products, salary \$1,200 to \$1,500. Applicants should apply to the United States Civil Service Commission, Washington, D. C., for application and examination for Form 1,312, or to the secretary of the board of examiners at any of the state capitals.



New Zealand Mineral Oil

On the western coast of the North Island of New Zealand, in the vicinity of Mount Egmont, and close by the sea at New Plymouth, there have been for many years promising indications of mineral oil, but attempts to bore for the oil have not met with much success, the wells apparently not being sunk to a sufficient depth. Lately, however, according to the United States Consular Report, three bores sunk to a depth of about 2,500 feet have resulted in a fair flow of oil being obtained, and also a strong pressure of natural gas. From these bores about 20 barrels of oil a day are now being obtained, this oil being shipped in a crude state to Auckland and Wellington, where it is used in the local gas works.

Obituary

WILLIAM WASHINGTON TAYLOR

William Washington Taylor, who was born at Fort Dearborn, Ill., October 31, 1858, where the Auditorium Hotel now stands in Chicago, died at Roundup, Mont., of blood poisoning, on December 29, 1911. Those who were at the meeting of the American Mining Congress will remember him from his forceful and genial personality. Mr. Taylor obtained his education at Notre Dame University, after which he entered politics and eventually became sheriff of LaSalle County. During his 12 years term of sheriff, he was called on in 1890 to settle the mining troubles at LaSalle,



WILLIAM W. TAYLOR

where he was shot and presumably pounded to death. In 1903 he became connected with the Spring Valley Coal Co. as general superintendent of the St. Paul Coal Co. He was in charge of the Cherry mine at the time of the disaster. His labors and grief at that disaster so affected his health that for a time his life was despaired of. Although not personally a physical sufferer as a result of the fire, it is probable that nothing ever affected him so much as the sufferings of others caused by the fire. Recently he was elected president of the St. Paul Coal Co.

E. R. BUCKLEY

E. R. Buckley, mining geologist, born at Millbury, Mass., September 3, 1872, died of pneumonia January 19, at the Stratford Hotel, in Chicago. From 1901 to 1908 he was Director of the Bureau of Geology and Mines of Missouri, and State Geologist. Since 1908 he has been mining geologist of the Federal Lead Co. Recently he opened an office in Chicago as a consulting engineer, and his sudden death will be a shock to his friends.

He was a life member of the Geological Society of America, American Institute of Mining Engineers, American Association for the Advancement of Science, ex-president of the American Mining Congress, member of the National Geological Society, member of the Mining and Metallurgical Society of America, Wisconsin Academy of Science, Arts and Letters, Wisconsin National History Society, American Society of Testing Materials, honorary member of the Black Hills Mining Men's Association, and member of the Wisconsin Clay Workers Society.

JAMES A. SNEDAKER

James A. Snedaker, wealthy mine owner and engineer, died at his residence in Denver, Colo., February 10, 1912, of ptomaine poison

undoubtedly contracted two days before from food of which he had partaken while en route home from attendance at the annual meeting in Duluth, Minn., of the Giroux Consolidated Copper Co., in which he was interested. His health was excellent when he started homeward, but he was violently ill before arrival at Denver. Mr. Snedaker settled at Aspen, Colo., when a young man of 23, and immediately met with success in the practice of his profession and in mining. His interests gradually extended until at present they are throughout the West. He was, for a few years, associated with A. E. Reynolds. He has been active in scientific and Masonic circles in Denver. He died at the age of 54 years.

WILLIAM C. WETHERILL

William C. Wetherill dropped dead of heart trouble in the lobby of the Symes Building, in which was his office, Denver, Colo., on February 10, 1912. Mr. Wetherill was known among mining men as the inventor of the magnetic ore separator bearing his name. He has taken an active part in the modern development of ore dressing and metallurgy. He was especially interested in methods for dressing and reducing ores of zinc, and, at his death, had been consulting engineer of the Empire Zinc Co. for a number of years. He was 65 years old, was an active member of the Colorado Scientific Society and frequently participated in its discussions.

來 來

Jeffrey-O'Toole Coal Cutter

The coal cutter described in this article is an entirely new device that Col. E. O'Toole, general superintendent of the United States Coal and Coke Co., suggested for the mines at Gary, W. Va. The Jeffrey engineers with the cooperation of Mr. O'Toole perfected the machine, which is now in successful operation. The machine is built to channel at various heights, depending upon the thickness of the seams, and is particularly useful in cutting thick seams where the presence of dust or gas limits the amount of explosive that can be used for each shot. In such cases the seam is cut in about its center and small charges of explosives are sufficient to bring down the upper one-half and lift the lower one-half.

One objectionable feature in connection with chain coal cutters has been the time and labor consumed in moving them from one place to another, and the necessity of loading them on trucks and hauling them from one room to the next after a cut has been made.

To overcome this loss of time, Colonel O'Toole has arranged the details of the machine so that it is self-propelling and requires no labor in loading. With this machine it is only necessary to connect up the driving chain, release the jacks, switch on the power to the motor, and move out of the room. Fig. 1 shows on the rear of the truck a self-winding and paying-out cable which carries the power for running the motor. Also, the cutter bar has an 18-foot diameter sweep consequently one set up is sufficient to cut clear across a room face.

The track should be placed in the center of room, as shown in

Fig. 1, which is the starting position, but if this is not practical on account of space for refuse, the end of the track may be curved so that the machine is in the center of the room when at the face. The runner, as soon as the truck-chain drive is disconnected, immediately starts the machine, and while the arm is swinging over from its position parallel with the track to a position where it starts to cut, the helper sets the jacks. The room face is cut in a semicircle 18 feet in diameter, and the machine advances 5 feet for each cut. The cutter arm is provided with a ratchet feed which is varied by an arrangement that causes the engagement of one or more teeth per revolution. The total time required to feed the arm in a complete semicircle is from 7 to 25 minutes, depending on conditions.

The fast feed is used to bring the cutter arm up to the coal and from the coal back to the center position. At the beginning of the cut a quicker feed can be used than at its center part, when the arm is fully under the coal. The machine operator can readily stop and start the feed by means of a disk friction clutch, which also acts as a safety slip in case the machine encounters material which cannot be cut. The bed frame of the machine consists of a circular steel casting upon which is mounted the motor, all gearing, and the cutter arm. This bed frame rests upon and revolves inside of a large steel ring which forms the stationary frame. Riveted to this ring at three points, 120 degrees apart, are cast-steel screw brackets, through which large adjusting screws pass. These screws are bolted to the top plate of the truck and are fitted with adjusting nuts to vary the height of the ring above the truck, and to tilt the cutter head at any desired angle.

The feed mechanism consists of a ratchet and lever operated by an eccentric on the main drive shaft. On the same shaft with the ratchet wheel is a worm which meshes with a worm-wheel on the drum shaft. A disk friction clutch mounted on the drum shaft engages a rope drum, on which is wound a steel rope. One end of this rope is fastened to the hub of the drum and the other end hooked to the stationary steel ring. Around the periphery of the circular bedplate are sheave wheels, over which the steel rope passes, and as the ratchet turns, the worm and drum revolve, winding up the rope and pulling the cutter arm around in a circle. The disk friction clutch on the drum not only acts as a safety slip but allows a variation in the feed. The ratchet is also arranged to engage one or more teeth at each stroke of the eccentric, thus permitting the feed to be varied at any time while the cutting is in progress.

The machine can cut entries as well as rooms. When cutting entries, it is placed close to one rib and the cutter arm started in on the other rib. It is then sent under the coal until it cuts up to the rib by which the machine stands. It is probable that in the Pocahontas field an average day's work is 140 feet of face per day. As the room is 18 feet wide, the ordinary chain machines make forty 3.5-foot cuts daily; that is, each cut requires for setting up and moving machine 15 minutes. Assuming that the time required to make a cut and move the O'Toole machine to the next room is 30 minutes, then 360 feet of face would be cut per day and a saving of 72 per cent. in time and two and one-half times increase in output would result from its use.



FIG. 1. JEFFREY-O'TOOLE COAL CUTTER

The Smokeless Coal Field of West Virginia

Legal and Business Conditions Which Operate to Promote the Wasteful Exploitation of Coal Lands

By Edwin Ludlow

The area of coal land stretching from the Pocahontas field on the Norfolk & Western Railway to the New River field on the Chesapeake & Ohio Railway, and served by these two railroads, and also by the more recently built Virginian Railway, between them, comprises a unique coal territory similar, in many respects, to the anthracite field of Pennsylvania; and from a commercial point of view, is in very much the condition of that field 30 years ago.

At that time each company was trying to get the best of some competitor and to work out a survival of the fittest by selling coal below cost. Those who remember the dilapidated appearance of the average anthracite breaker of those days, and also knew of the wasteful methods of mining then in vogue, will realize by comparison with the present, what advantages have accrued to all, both miners and consumers, from the common-sense business methods by which the various companies have drawn together their interests and brought industrial peace where there had formerly been only ruinous competition, and have been able to double the life of that field by using their increased revenue in opening deeper mines and working thin and impure seams that could formerly only have been operated at a heavy financial loss.

The average appearance of the mines in the smokeless field will tell any trained observer that the same suicidal policy is being pursued here. That while coal is being sold by the newer and more fortunately located mines at a small profit, the older and more expensive must either shut down and their organizations scatter and their entire investment deteriorate, or continue to mine at a loss, hoping for some change that will bring them better times. In the meantime, they cannot afford to install new machinery to meet the increasing length of their underground hauls, or other improvements, that might be a factor in increasing the tonnage and reducing costs; and more important of all, they can only afford to work the best coal in their mines, and thin or impure parts of the vein are left unworked, and large areas of coal that could and should be mined to extract their full tonnage are abandoned and permanently lost, as with the robbing back of the best coal the sections not worked can never again be reached and the coal reserves of the country are thus wasted. Many thin veins lying immediately over the thicker ones that could only have been worked either simultaneously with the thicker ones or before the thick ones were mined at all, have been permanently lost as the working out and robbing of the underlying vein has broken the separating rock so that the upper vein is hopelessly crushed and can never be mined profitably.

This exhaustion of the smokeless coal is as serious a problem for the country as the exhaustion of the anthracite field. This coal is not only smokeless but gives the highest tests as a steam producer and is only equaled by the best grade of Cardiff Admiralty coal in England, as shown by an analysis of New River Admiralty coal recently shipped to the United States navy. The samples were taken by a Navy inspector and the analysis made by the government chemist, resulted as follows:

Moisture, .84; volatile matter, 17.56; fixed carbon, 77.45; ash, 4.13; sulphur, 0; British thermal units, 15,100. On dry basis, 15,227.

The coal is constantly increasing in demand not only along the Atlantic seaboard, where vessel owners and other steam users want the best, but is the only coal to replace the small grades of anthracite for furnishing power in the cities, both East and West, where ordinances prohibit smoky chimneys. Chicago, St. Louis, Cleveland, and other western cities, use millions of tons of this West Virginia smokeless coal in spite of their close proximity to their local coal fields, that can furnish a good steam coal delivered at less than the freight rate from West Virginia. They don't use this smokeless coal because they want to, but because they have

to, and they could and would pay the few cents a ton more that would make the difference to the mine operator between profit and loss; but as the annual tonnage always increases a little more than the increased demand, and as long as anything but ruinous competition is liable to increase the coal operators' troubles by adding a jail sentence to his other woes, so long will this insane policy of giving away the best steam coal mined in this country continue.

There is one other hope for the coal operator, and that is, to so increase the demand by the widening of his market that surplus stocks will be absorbed and prices automatically rise to a living basis. This is where our friends in England can show us something. The exports from England for the first 10 months of this year were:

Country	Quantity Tons	Value (Pounds Sterling)
Russia.....	3,093,037	1,700,697
Sweden.....	3,084,636	1,575,164
Norway.....	1,582,672	749,920
Denmark.....	2,274,927	1,149,464
Germany.....	7,347,881	3,415,699
Netherlands.....	1,769,482	866,882
Belgium.....	1,451,067	619,643
France.....	8,486,717	4,530,473
Portugal.....	879,077	548,657
Spain.....	2,484,365	1,533,923
Italy.....	7,564,879	4,413,180
Austria-Hungary.....	825,333	422,340
Greece.....	583,939	326,750
Turkey.....	420,746	267,054
Egypt.....	2,563,792	1,612,797
Algeria.....	887,243	489,743
United States.....	6,120	4,242
Chili.....	579,755	399,743
Brazil.....	1,353,591	1,020,102
Uruguay.....	744,581	567,304
Argentina.....	2,657,609	1,958,350
Gibraltar.....	272,533	171,584
Malta.....	348,216	214,688
British South Africa.....	58,725	38,654
British India.....	168,834	107,589
Straits Settlements.....	25,811	20,313
Ceylon.....	214,884	163,076
Other Countries.....	1,527,346	1,073,432
Total Anthracite.....	1,984,480	1,496,271
Total steam.....	38,831,231	22,407,044
Total gas.....	8,672,664	4,218,602
Total household.....	1,258,758	658,882
Other sorts.....	2,510,317	1,200,664
Totals.....	53,257,450	29,981,463
Total coke.....	837,891	630,866
Total briquets.....	1,347,495	943,927
Total coal, coke, and briquets....	55,442,836	31,556,256

While Northern France and Germany and North Europe are too close to England to permit of our competing on an equal basis, we have found that with reasonable ocean freights, we could compete at all Mediterranean ports, and allowing half of France as representing the imports in southern ports, the total Mediterranean tonnage open for competition is 19,611,779 tons; equal to the entire output of smokeless coal.

During the extremely slack business of the past summer, several of the larger companies had their agents in Europe trying to get a share of this business; and while trial cargoes were shipped in English vessels at rates of \$s 6d., when the movement was found by the English ship owners to be a constantly increasing one, and that the coal gave entire satisfaction wherever used and would interfere with England's own coal business, the rates went up to 12s. a ton, and as all prices had to be made delivered, the trade has languished and will probably continue to languish as long as the United States has no merchant marine of its own and must depend upon English ships for their export trade.

Next consider the amount of coal England puts into South America, 5,214,407 tons in 10 months of this year. If this smokeless field could only get a fair percentage of this business, the surplus stocks at tidewater would be a thing of the past and New England would pay a living price for her fuel instead of 90 cents a ton for coal that costs \$1 to mine. The English received for this coal on board vessel \$3.30 to \$3.50 per ton. The distance from England to South America is greater than from Hampton Roads, and the smokeless coal has been sold as low as \$2.50 per ton f. o. b. vessel, although that price is 50 cents per ton less than the coal should bring to give the the mine owner a proper return on his investment.

Some of our conservation friends may say that it is unwise to deplete our resources for the benefit of foreign countries. It is only necessary to refer to any one familiar with the Alaskan situation to show the futility of carrying the conservation idea to

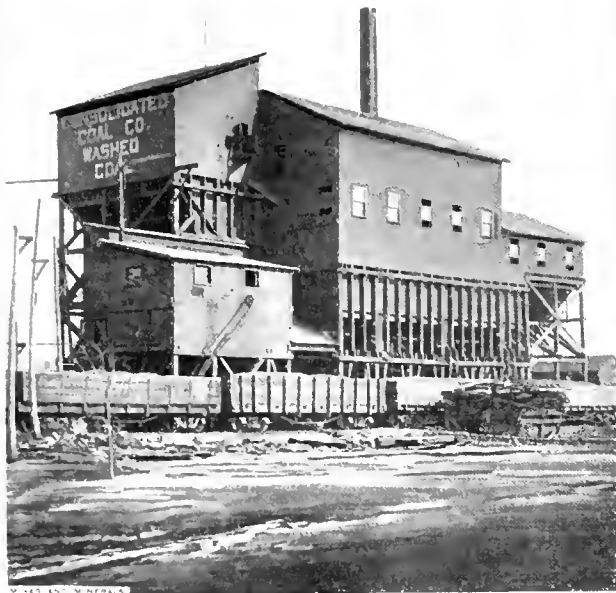

FIG. 1. COAL WASHERY, 1,000 TONS CAPACITY, SAGINAW, MICH.

these impractical extremes. As a matter of fact, an export market that should take the surplus coal and assist, by eliminating competition or restriction, in bringing the revenue of the coal operator to a profitable basis, would conserve our resources of coal by causing him to mine the seams that cannot now be worked profitably; also by the installation of washing and other types of coal cleaning plants that would enable him to work parts of his mine where the coal is now so banded with impurities that it cannot be cleaned and prepared at a profit, and is consequently abandoned.

The increasing revenues coming to the operator in the anthracite field have caused these things to be done there, and they would also be done here. It is useless to say that there are too many mines. While that is true, still the mines have been opened, the money invested, and no one is going to give up his investment for the benefit of others. Restricting output is another favorite suggestion, but all who are familiar with coal mining, know that restriction is an expensive luxury that none but the rich operator can stand. The fixed cost of ventilation, pumping, and supervision, not to speak of interest on the investment, goes on during the period of restriction the same as when the mine is in operation; and the consequent cost per ton of coal mined in any month of restricted output is unavoidably so much higher that the selling price cannot cover it, and the operator is lucky when it does not absorb all of the profits from stores and rents.

The position of the coal operator in the smokeless field is not a happy one. If he meets his brother operator, and remarks that coal is selling too cheap, he is immediately a conspirator in restraint of trade and liable to fine and imprisonment. If he tries to sell his coal in a foreign market, he finds that his own country, while rich in battleships, is very short on merchant marine, and he has to go to London to get a vessel, and if his orders interfere with any of John Bull's business,

he doesn't get it at a price that enables him to compete. The only one who is the gainer by this situation is the manufacturer, who with his heavy protection on all he makes, is able to buy his fuel from his own country at less than the cost of production.

The interesting question is: What are we going to do about it? Our paternal government, while willing to give unlimited advice as to the purchase of oxygen helmets and how to install the best methods of elaborate and costly sprinkling devices to keep down coal dust and avoid explosions and to show how these have lessened the number of accidents in the anthracite region, still if asked some simple question as to how we can so consolidate our interests as to get a price for coal that would enable such expenditures to be made, will look pained and advise that even a discussion of such a question is illegal.

There is no difficulty in getting lawyers to tell what shall not be done, but all confess that a legal solution of the problem is impossible, as the recent interpretations of the Sherman Act have only made the real meaning more obscure.

Will Congress help us? Perhaps, but not in a year of political activity preceding the presidential election, when the voters might be led to think from some muck-raking magazine that the so-called coal barons were getting a helping hand.

The truth is they need it, as their choice is jail or the poor house.

來 來

Consolidated Coal Washery at Saginaw, Mich.

A coal washery, possessing a number of unusual and interesting points in design, was put in operation several years ago in the city of Saginaw, Mich., by the Consolidated Coal Co., whose plants were described in October, 1911, MINES AND MINERALS.

It is a well-known fact that no two coals are exactly alike, even in the same field and seam, and that they vary in kind and amount of free impurities, such as pyrites, slate, fireclay, etc., also in the facility or difficulty experienced in eliminating or reducing them. It is furthermore found, that some coals when mined contain small particles of coal that will float on water, whereas other fine coals are all of appreciable size that will readily settle. Some coals will break into cubes, others into slabby pieces, and others

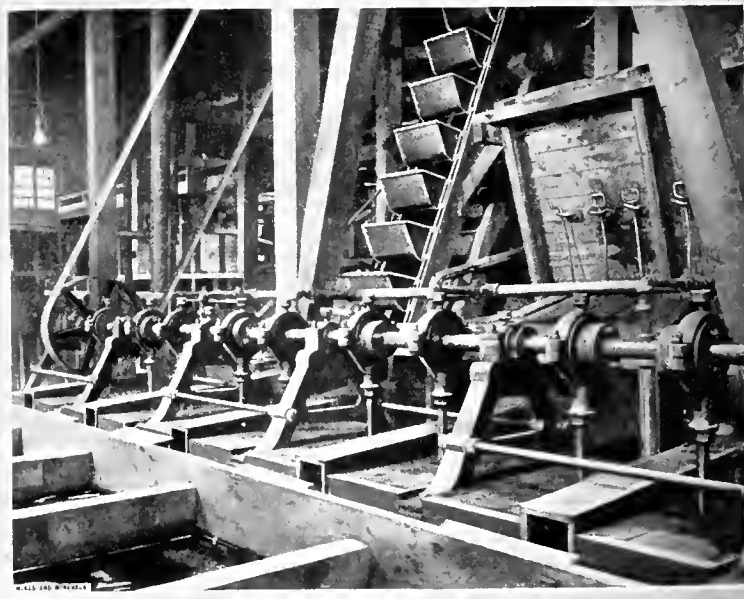

FIG. 2. LUHRIG REWASHING JIGS AND WASHED COAL ELEVATOR

again into pieces more or less conchoidal in shape. Very little or no fireclay is found in the slack of some coals, in others the percentage is high. The fine coal in some cases is very clean and the nut sizes are dirty; in other cases the reverse is true.

These varying physical features, in addition to the operating and commercial considerations, must be understood when designing washing plants for cleaning coal intended for fuel.

An efficient design for a plant also means that the machinery for unloading shall require a minimum of labor and maintenance; that the coal throughout the plant shall be dropped and handled as little as possible; that the jigs shall be of proper design and number to separate the impurities from the coal; that the equipment for recovering the coal from the wash water be sufficient; and that the screening or sizing equipment shall be ample.

Dropping coal invariably means that pieces will be chipped off, a larger proportion of slack and smaller sizes produced, and consequently a lower total price realized than would have been the case had degradation not taken place.

An insufficient number of the wrong kind of jigs will result in a washed product containing impurities, thus reducing its desirability as a fuel and making it more difficult to market.

A screening equipment of ample proportions and proper design is absolutely essential to a successful washery, as coal not well sized is frequently rejected by dealers and consumers.

Coal that is not recovered from the wash water is circulated with the water to the jigs, and ultimately finds its way to the refuse pile, thus causing a direct loss.

In the Saginaw plant some of the special considerations in its design were: (1) The large number of mines from which the slack would be received; (2) the large range in ash content (12 per cent. to 40 per cent.); (3) the washed products would be sold in competition with Western Pennsylvania coals in Bay City and Saginaw markets. These several requirements, when considered in conjunction with the peculiar physical features of the coal, made it apparent that special treatment of the fine coal would be necessary, and it was decided to equip the plant with a set of Stewart jigs and a set of Luhrig fine-coal jigs for rewashing the material under $\frac{1}{4}$ -inch diameter, which would be only partly cleaned in the primary washing equipment.

That this plan was the proper one to follow is evident when the analyses for ash of the raw coal and the various products are considered. For the purpose of a test to determine what the plant was doing, samples were taken at regular intervals during a day's run of raw coal, washed nut, washed slack through 1-inch perforation, primary washed slack through $\frac{1}{4}$ -inch round perforation, rewashed slack through $\frac{1}{4}$ -inch round perforations, and the refuse.

On this day the raw coal contained 24.65 per cent. ash, the washed nut 3.82 per cent., the washed slack through 1-inch round

perforation, 5.71 per cent., the primary washed slack through $\frac{1}{4}$ -inch round perforations, 8.89 per cent., and the refuse, 56.5 per cent.

It will be seen from these results that the $\frac{1}{4}$ -inch slack before rewashing contained nearly 8.89 per cent. ash, or nearly 5 per cent. more than the washed nut, and that rewashing reduced the ash content to within 2 per cent. of that in the washed nut coal.



FIG. 3. PART OF INTERIOR OF WASHERY, SAGINAW, MICH.

The plant was designed and built by the Link-Belt Company, Chicago, and we are indebted to J. H. D. Petersen, engineer of the coal-mining department of that company, for the information furnished in this article.

來 來

Michigan Coal Production, Dec. 1, 1910, to Aug. 1, 1911

Average number of mines in operation	24
Average number of employes	2,520
Average number of hours worked per day	7.9
Average number of days worked per month	17.6
Average daily earnings of each employe	\$3.41
Aggregate sum paid in wages	\$1,224,010.88
Total number of gallons of oil used	15,575
Total number of kegs of powder used	29,564
Aggregate output of mines in tons of picked coal	519,919
Aggregate output of mines in tons of machine coal	375,701
Aggregate cost of output	\$1,689,617.62
Average cost per ton	\$1.88

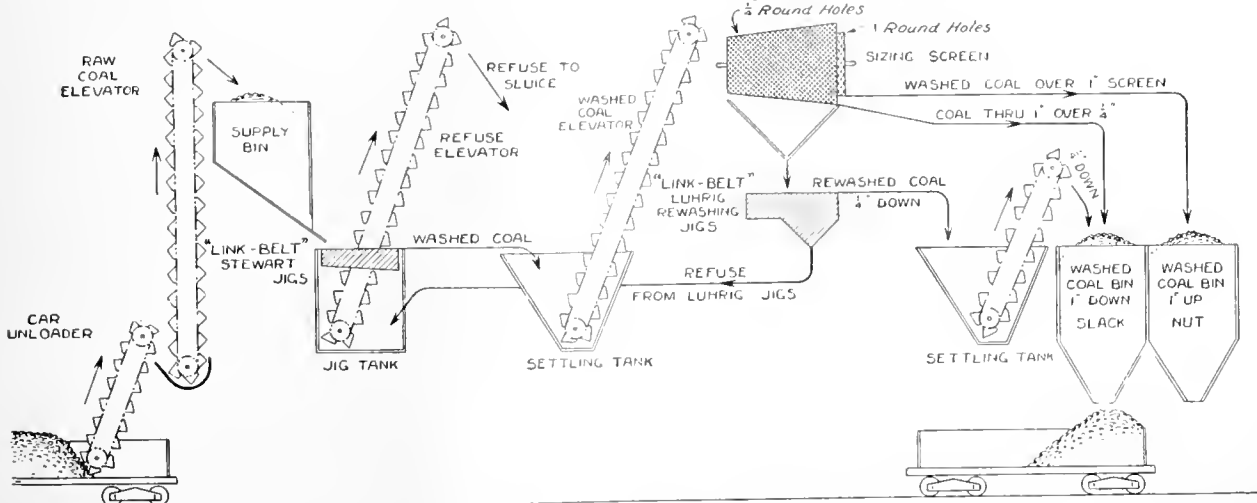

FIG. 4. FLOW SHEET SHOWING METHOD OF TREATMENT, CONSOLIDATED COAL COMPANY WASHERY

Economy in the Use of Steam

Treatment of Bad Water—Requirements for a Good Boiler. Feedwater Heating

By R. H. Rowland*

The question of the economical use of steam is from time to time brought home to all, especially when by some addition to our plant we have drawn upon or actually eliminated the boiler power reserve; and it is then a question as to whether we install an additional boiler plant, or whether there is a more economical and expeditious method of deriving the same result.

It is my intention to consider here the various ways of economizing steam.

In the care of boilers attention should be paid to eliminating the scale or deposit that forms inside. The custom of allowing boiler scale to form, and afterwards chipping it off, when the boiler is cleaned, is similar to allowing a child to get sick so as to doctor it; whereas, after analysis of the boiler feedwater, this formation may be almost, if not entirely, eliminated by an ounce of chemical cure.

When a boiler scale of $\frac{1}{16}$ inch has been proved to cause an additional consumption of fuel of 10 per cent., a scale of $\frac{1}{8}$ inch an additional consumption of 22 per cent., a scale of $\frac{3}{16}$ inch 33 per cent., and a scale of $\frac{1}{4}$ inch 47 per cent., or practically one-half the fuel consumption, the importance of this detail is better realized. It can also be easily realized that apart from the fuel economy the scale or deposit must seriously add to the cost of boiler repairs.

So many and various boiler disinfectants have been tried and failed, that many operators and engineers are prejudiced against all; nevertheless, it is a fact that suitable disinfectants can be found for all feeds, so that in the case of bad water, it is advisable to expend considerable money in the matter of experiments.

There are many mines that have to rely on boiler feedwater that is pumped from the mine. If this be basic or acid, water-softening machinery should not be overlooked, and inasmuch as the action of the air appears to a great extent to soften the water, and presumably cause it to deposit some portion of the lime held in solution, the use of a large pond, or reservoir, is to be recommended.

If water is particularly bad, the adoption of water-softening machinery is almost essential; and although it entails considerable initial expenditure, it undoubtedly results in a reduced consumption of fuel, and also in boiler repairs. Therefore, wherever possible, the use of a disinfectant is a preferable and simpler way.

The kind of boiler to be adopted, and the pressure at which it is to work, requires consideration.

Engineering experience and scientific investigation have established the following as the requirements of a perfect steam boiler:

1. The best materials sanctioned by use, simple in construction, perfect in workmanship, and not liable to require early repairs.
2. A mud-drum to receive all impurities deposited from the water in a place removed from the direct action of the fire.
3. A steam and water capacity sufficient to prevent any fluctuation in pressure or water level.
4. A large water surface for the disengagement of the steam from the water to prevent foaming.
5. A constant and thorough circulation of water throughout the boiler, in order to maintain all parts at one temperature.
6. The water space to be divided into sections, and so arranged that should any section give out, no general explosion could occur; therefore, the destructive effect would be confined to the escape of the contents. Also large and free passages between the various sections to equalize the water line and pressure to all.
7. A great excess of strength for any legitimate strain, and so constructed as not to be liable to be strained by unequal expansion; also, if possible, no joints exposed to the direct action of the fire.
8. A combustion chamber so arranged that the combustion of gas in the furnace will be completed before the escape to the chimney.

* Civil and Mining Engineer, Brooklyn, N. Y.

9. The heating surface as nearly as possible at right angles to the currents of heated gases, so as to break up the currents and extract the entire available heat from them.

10. All parts to be readily accessible for cleaning and repairs. This is a point of greatest importance, as regards safety and economy.

11. Proportioned for the work to be done and capable of working to full load capacity, always with the highest economy.

12. The very best gauges, safety valves, and other fixtures.

Inasmuch as the finest kind of slack coal has its especial use and value, and that mines and collieries produce so little waste fuel that it is largely supplemented by saleable fuel, it would appear that the cost of a new plant should be recovered from the additional sale of fuel.

It should be remembered, also, in deciding on the steam pressure, that almost as great an expenditure of fuel is required to obtain a pressure of 50, as 80 or 100 pounds, inasmuch as the greater expenditure of fuel is in the boiler heating of the water. It would seem that if this is done the higher pressure would take very little additional heat, and this gains significance from the fact that with the higher pressures the economy of automatic expansion is greatly increased. Not long ago 80 to 100 pounds was looked upon as the pressure limit of a simple engine, while today there are mines in this and foreign countries using steam, with compound engines, at 300 pounds and even greater pressures.

The use of hot boiler feedwater is recommended where advantage is taken of the exhaust steam to heat the water previous to its being forced into the boiler by a feed-pump. With such an arrangement an economy can be effected of from 10 to 15 per cent. in the fuel consumption while heating the water to about 190° F. in the case of an exhaust injector, and greatly reducing the repairs to the boilers.

With the best arrangements the water can be introduced into the boiler at a temperature of from 260° to 270° F. It can be understood that with hand stoking this arrangement will greatly facilitate the stokers' labor, and should remove any ground for complaint on the score of defective stoking.

As from 12 to 35 per cent. of the fuel consumed is carried off in the gases that go to the chimney, and except for the maintenance of natural draft is wasted, the advantage of an economizer is apparent on examination of the following table, which shows the percentage of saving of fuel by the heating of feedwater.

TABLE 1. PERCENTAGE OF SAVING BY ECONOMIZER (STEAM AT 60 POUNDS)

Temperature Leaving	Temperature of Water Entering Economizer			
	32° F.	40° F.	50° F.	60° F.
60	2.39	1.71	.86	
80	4.09	3.43	2.53	1.74
100	5.79	5.14	4.32	3.49
120	7.50	6.83	6.05	5.23
140	9.20	8.57	7.77	6.97
160	10.90	10.28	9.50	8.72
180	12.60	12.00	11.23	10.46
200	14.30	13.71	13.00	12.20
220	16.00	15.42	14.70	14.00
240	17.79	17.13	16.42	15.69
260	19.40	18.85	18.15	17.14
280	21.10	20.56	19.87	19.18
300	22.88	22.27	21.67	20.92

An inferior class of fuel can be used and stoking facilitated if supplemented by some system of forced draft. This can be acquired by the use of thin fire-bars set $\frac{1}{8}$ inch to $\frac{1}{2}$ inch apart, and the use of usually two blowers or long cast-iron tubes of trumpet terminations. A very small central nozzle is fixed at the outer end of the tube, and a jet of steam is injected through it, into a closed ash pit; thus giving motion to the air in the tube, and causing a considerable amount of pressure in the tube; in most cases $\frac{1}{2}$ inch to $\frac{5}{8}$ inch of water gauge. This blast can be regulated by means of a valve under the control of the stoker.

Probably the greatest of all economies is obtained by using steam expansively; for not only is the steam saved from the point at which the engine cuts off, but in many cases a further saving of

fuel is obtained in the reduction, or practically total absence, of back pressure. It was a matter of great surprise to me some time ago when viewing a pair of high-pressure winding engines to see how rapidly this rose as the engine gained speed. Of course a limit of cut-off is reached, governed by the shocks caused to the machinery by great changes in pressure, and the condensation due to the variations in pressure and temperature.

The compound engine, while exhausting its steam into a receiver, from which the low-pressure cylinder is fed, allows of great expansion, inasmuch as expansion occurs in either cylinder. In view of the fact that triple expansion engines are not seen at collieries and mines, it will be unnecessary to consider them.

There have been many objections raised to the use of compound engines for hoisting, principally because they do not start quickly. This latter objection, however, has now largely disappeared, and it is customary in many plants to adopt some arrangement by which high-pressure steam can be passed through a reducing valve into a low-pressure cylinder at starting if required, and the use of a balance rope has been found to be of great assistance. The great weight of the spiral drum, which in many cases accompanies this arrangement, as also the large simple engine, is a very great drawback, inasmuch as they have to be started from a condition of rest, and gotten into a high speed in a very short time, and it is an absolutely dead load at the start. Toward the end, however, the weight acts like a flywheel, and accounts to some extent for the energy absorbed.

It would seem that a quick start, a high speed during the wind, and a prompt return to rest, are the essentials required of the modern winding engine.

It is necessary to cover boilers, steam pipes, and engine cylinders with non-conducting, non-heat-radiating materials to economize in steam. Although well known and recognized as having a great bearing on the economy of steam, this is a matter often overlooked by superintendents, managers, and engineers, in the pressure of other work, at both large and small collieries.

In the case of boilers which require repairs, and of pipes, which need joints to be made from time to time, the covering should be of such a nature that it may be readily removed and replaced, without loss of time or material. For this reason, and also on account of its being an exceptionally bad conductor, silicate of cotton, covered with thin sheet iron, is to be recommended.

There are many companies that look at this matter from a monetary standpoint, without realizing that a cheap compound is of little or no use with reference to non-conducting qualities, but it must be apparent that well covered pipes will convey steam great distances without any serious loss; at a certain mine steam is stated to be conveyed 6,000 feet at a loss of only 21 per cent. or 13 pounds, while at another colliery steam is conveyed but 1,000 feet with a loss of 19 per cent. It is an essential fact, therefore, that the boilers should not only be covered, but also substantially roofed in, steel and iron being preferably alone adopted.

In large winding plants, it is now becoming customary to adopt separate engines for condensing, particularly so if the engines employed are of the compound type. The high speeds of the modern hoisting engine prevent the direct attachment of the ordinary bucket condensers, and since it has been stated that an economy in fuel of 20 per cent. is obtainable with triple expansion engines, and

of over 50 per cent. with low-pressure engines, it appears strange that so few colliery engines condense, especially taking into consideration the great advantage obtained in an additional 12 to 15 pounds of pressure.

采 采

Penn-Mary Rock Larry

The handling of waste material at any mine is a subject which appeals to mine managers. At the Penn-Mary mine, Heilwood, Pa., an interesting rock larry was designed and put in use. As shown in Fig. 1, it has three swinging doors, one in front and one in each side. The larry has 4-foot 8½-inch gauge, holds 12 tons of rock, and is propelled by a 25-horsepower electric motor, with reduction gear. The rock is dumped from the mine car into this larry until it is filled, after which it is run by its own motor to the end of the rock dump. The three doors are opened by one blow of a hammer, allowing the car to empty its contents on the front and two sides of the dump. There is considerable economy in a rock car of this description, because it allows the mine cars to be kept moving and in service in the mine; further, the rock dump requires no trestling, as the car makes its own track fill. We are indebted to H. P. Dowler, superintendent, for information concerning this larry.

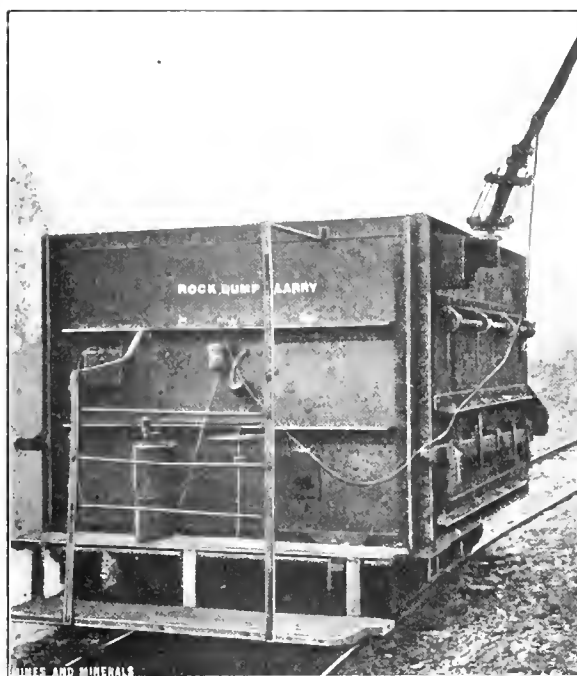

FIG. 1. ELECTRIC ROCK LARRY

采 采

American Institute of Mining Engineers

The 102d meeting of the American Institute of Mining Engineers was held in New York City, beginning Monday evening, February 19, 1912. Headquarters were at the Institute office, in the Engineering Societies Building, 29 West 39th Street, where a bureau of information, in charge of George Buckman, office manager of the Institute, was maintained. The sessions were held in one of the assembly rooms of the building.

The arrangements for the meeting, apart from the technical sessions, were in the hands of Benjamin B. Lawrence, chairman; James Douglas, vice-chairman; Bradley Stoughton, secretary-treasurer; C. P. Perin and Dr. George F. Kunz. All local matters were under the management of Mr. Bradley Stoughton, 165 Broadway, New York, N. Y., while the control of the papers and discussions was exercised by the president and the secretary of the council, as usual.

Details of the technical sessions of the meeting were given in the program of the local committee, which was furnished to each member or guest on registration at Institute headquarters.

The annual business meeting of the Institute was held at the Institute headquarters on Tuesday, February 20, 1912, at 10 A. M. The following officers were elected:

For president of the council, James F. Kemp, New York, N. Y. (Term expires February, 1913.) For vice-presidents of the council, Benjamin B. Thayer, New York, N. Y.; Karl Eilers, New York, N. Y.; Waldemar Lindgren, Washington, D. C. (Terms expire February, 1914.) For secretary of the council, Joseph Struthers, New York, N. Y. (Term expires February, 1913.) For members of the council, Joseph W. Richards, South Bethlehem, Pa.; John H. Janeway, Jr., New York, N. Y.; Sidney J. Jennings, Dobbs Ferry, N. Y. (Terms expire February, 1915.) Directors: E. B. Kirby, Geo. C. Stone, C. F. Rang.

✻

Correspondence

✻

Grade for Rope Hauls

Editor Mines and Minerals:

SIR:—Re letter in February issue on "Grade for Rope Hauls," would say that satisfactory results can be obtained with endless-rope haulage on pitches anywhere from flat to 25 degrees. The writer has seen and operated many miles of rope haulage with grades which varied within the above limits. In most cases the rope was carried above the cars.

JOHN T. FULLER

Panel System of Longwall

Editor Mines and Minerals:

SIR:—The panel system of longwall mining described by Mr. C. Krebs in your September number is a decided improvement over the prevailing pillar-and-stall system now generally adopted in the bituminous coal fields of this country; but the plan as outlined can further be modified by eliminating all to the entries designated "2 L-1, 2 L-2," etc., for two purposes: first, to save the time required to make the connection with the respective face entries; second, on account of the reduction in cost.

Since the driving of the entries would interfere with the working of the longwall face, and the distance between the cross-entries is 11,000 feet, under the most favorable conditions it would require from eight months to a year to make the connection, and as to the item of cost, under the yardage rates now prevailing in Indiana with mining machines the yardage work for coal alone in the driving of these entries and cross-cuts would be equivalent to $2\frac{1}{2}$ cents per ton if all of the pillars are extracted.

With Mr. Krebs' method it would be necessary to carry a rock wall along the roadway, and no benefit can be seen from having the entries driven ahead in the face. If, therefore, the conditions of the mine permit longwall operations, the method as shown on the enclosed sketch will be even better, less costly, and enable quicker development. Instead of driving the panels the full distance of 11,000-foot block, it is suggested to take half the distance, and as soon as the center of the block is reached, work out the intermediate block on the retreating system with the use of the roads established for the working of the first series of blocks.

CARL SCHOLZ

Allowable Error in Closing Survey

Editor Mines and Minerals:

SIR:—I wish to comment on C. G. O.'s question relative to error of closure in mine surveys.

While it is evident that we must have some limit on our angle tie, say 3 minutes, I believe that it is not wise to set a certain limit

on the error which accumulates from the measurements, or the error of closure of the traverse. From the standpoint of a bituminous mine engineer I would say that the error that we allow as acceptable depends wholly upon conditions. The following cases may be illustrative:

Consider two entries driving to the outcrop. Suppose a line had been carried in the air-course independently of the one in the heading, these lines being tied after say 1,000 feet had been driven, these entries to be finished when the outcrop is reached at a distance of about say 600 feet. Suppose that the error of closure was 1 : 1,500. I should consider this allowable, since nothing further depends on the values of our stations in these entries excepting a traverse to the outcrop.

Consider again two headings driving to meet, say through rock, where an error in meeting of say a few feet, might cause expense on account of poor alinement. In this case I should hold myself to a maximum error of about 1 : 5,000, a limit which is not difficult to keep within, in good work.

Consider also two different places in the same mine. Supposing that we have two entries driving to meet each other in each place.

The line necessary to run in order to close a traverse for the first two entries is only say 2,000 feet. For the other it is say 10,000 feet. In the first case we need the headings for an airway only. Suppose that our error of closure is 1 : 2,000. We know by this that our entries would not miss by more than a foot or two. Consequently I would let this stand. Suppose that our other two entries are to be connected for a motor road. A failure to meet by 2 feet would be the most that we could allow ourselves. In order to be sure of this, our traverse could not have an error greater than 1 : 5,000.

Another thing to be considered is the expense of the surveys, and the fact that whether the result we aim for will warrant the expenditure of the money necessary, when we resurvey and trace over old lines to find small errors.

In other words, if C. G. O. wants a value for his constant, I would say, let each engineer put in a different constant for each class of work, getting away from the fixed idea of going by rule, and paying some attention to the theory of precision of measurements.

WILLIAM MCN. SCHOFIELD, S. B.,

Eckman, W. Va.

Mining Engineer

Shale-Oil Enterprise in New Brunswick

It is stated by Consul Michael J. Hendrick, Moncton, Can., that oil-shale lands in that and adjoining counties of New Brunswick have been acquired by parties who purpose development on a large scale. Local newspapers state that Sir William MacKenzie and his Canadian Northern associates have made extensive purchases of oil-shale lands. The plan is to expend about \$2,000,000 in the construction of a plant with retort and refining machinery, as used in the Scotch shale-oil fields, for the distillation of oil and securing the sulphate of ammonia and other by-products.

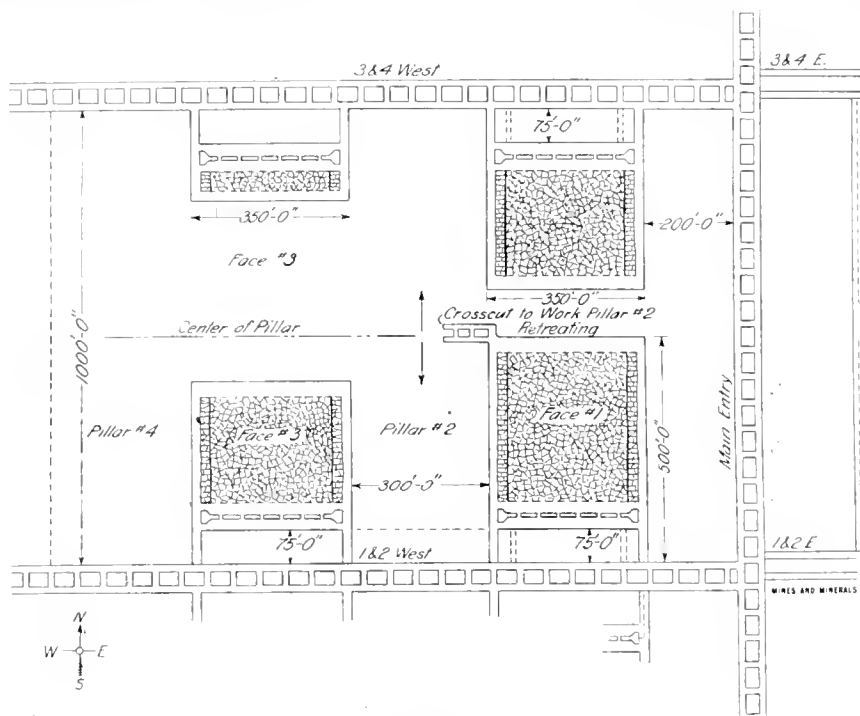

PANEL SYSTEM OF LONGWALL

Electrical Symbols for Mine Maps

Suggested Symbols and an Example Showing the Method of Application and Interpretation

By H. H. Clark*

The following is an abstract of the paper read at the Coal Mining Institute of America held in Pittsburg, December 20, 1911:

Some time ago the Federal Bureau of Mines began the preparation of a list of symbols to be used in reporting mine examinations. This list was designed to cover electrical apparatus and many other things as well.

When the new Pennsylvania mine law went into effect, the list of electrical symbols was revised and enlarged with the idea that it might, at some future time, be of use to those interested in the preparation of mine maps for showing the location and character of

used for other purposes in the same field. Electrical apparatus is frequently represented by symbols in engineering work above ground, and in preparing the list of symbols which is used by the Bureau of Mines certain characters were included which, in the past, have been quite generally used in electrical diagrams.

In making up the list of symbols, it was comparatively simple to select characters for apparatus and machines, but the representation of conductors was not so easy. If there are only one or two conductors in an entry, they may be easily shown by lines of different colors or by lines made up of different arrangements of dots and dashes. If there are many conductors and the scale of the map is 200 feet to the inch, this method is not so satisfactory.

The following method, which is general in its application, will hardly be as clear as the line method, when only one or two conductors are involved; however, it will probably be less confusing where several different circuits are to be shown on small scale maps. A description of the method is as follows: Letters are used to indicate conductors: thus *T* denotes a trolley wire, *B* a bare low voltage conductor, etc. Figures are used in conjunction with the letters to

denote the number of conductors of any kind. Thus *2T* denotes two trolley wires, and *3B* denotes three bare conductors. Other kinds of circuits are denoted by other letters. These letters are placed on the map along the side of an entry to show what circuits are passing through that entry. Whenever a conductor is added or dropped, a new symbol is put on the map at the proper place, showing one letter more or less as the case may be.

In Fig. 1 there is shown the list of symbols covering machines and miscellaneous apparatus. This list shows more or less apparatus that is not used in every mine, some that is used in but very few mines, but it was the intention to make the list as complete as possible. The machine symbols are based upon practice which has become more or less standard by continued use. Explosion-proof motors are represented by enclosing in a square the symbol for the open motor. The transformer symbol is that used by the National Electrical Contractors' Association.

<u>MACHINES</u>		<u>DUTY</u>				<u>MISCELLANEOUS</u>	
		FANS	PUMPS	HOISTS			
<u>MOTORS</u>					<u>TELEPHONES</u>		
A.C. LOW VOLTAGE OPEN					<u>LIGHTNING ARRESTERS</u>		
" HIGH " " "					<u>TERMINAL AND JUNCTION BOXES</u>		
" LOW VOLT. EXP. PROOF					<u>JOINTS</u>		
D.C. " " " "					<u>SWITCH BOARDS</u>		
" " " OPEN					<u>MAN HOLES</u>		
<u>GENERATORS</u>					<u>CONDUITS</u>		
A.C.					<u>SECTION INSULATORS (IN TROLLEY)</u>		
D.C.					<u>BORE HOLES FOR WIRES</u>		
ROTARY CONVERTERS					<u>END OF ELECTRIC WIRING</u>		
MOTOR GEN SET, HIGH VOLT. MOTOR					<u>MARGINAL NOTE</u>		
" " " LOW " "					<u>CIRCUIT BREAKERS</u>		
TRANSFORMERS					<u>STARTING RHEOSTAT</u>		
					<u>LAMPS</u>		
					ARC		
					INCANDESCENT		
					<u>SIGNALS</u>		
					LIGHTS		
					BELLS OR GONGS		
					<u>FUSES</u>		
					OPEN LINK		
					CARTRIDGE		
					<u>GROUND CONNECTIONS</u>		
					TO EARTH		
					TO PIPE		
					TO RAIL		
					CROSS BONDING OF PIPE & RAIL		

NOTE: THE FIGURES USED IN CONJUNCTION WITH THE MACHINE SYMBOLS REPRESENT THE H.P. CAPACITY OF MOTORS OR K.W. CAPACITY OF GENERATORS AND TRANSFORMERS.

FIG. 1

electrical apparatus, as required by Paragraph 14, Sec. 1, Article XI, of the New Code.

If those interested in this matter should adopt one set of symbols for the purpose, at least two advantages would be gained:

First. The advantages resulting from uniformity of practice, which are too obvious to require discussion, and—

Second. Every individual desiring to use symbols would not have to spend the time and thought necessary to develop a system of his own.

There is also another probable advantage. A system of symbols, to be of general application, must be considered from so many view points and by so many different people that the resulting plan would be more complete, more flexible and more satisfactory than a list prepared under other conditions.

There is nothing absolute about a list of symbols, the characters are all arbitrary, although it is best to interrelate them when this does not involve complication. The main thing is to select characters that are distinctive, easily made and duplicated, and not

*Electrical Engineer, Bureau Mine.

tion to make the list as complete as possible. The machine symbols are based upon practice which has become more or less standard by continued use. Explosion-proof motors are represented by enclosing in a square the symbol for the open motor. The transformer symbol is that used by the National Electrical Contractors' Association.

As to the miscellaneous list, the telephone symbol was selected as being distinctive and easily made and duplicated. The old conventional symbol has been used for ground connections with the addition of letters to show the kind of ground connection.

In Fig. 2 are shown the symbols for conductors and switches. The application of the conductor symbols will be shown more fully in Fig. 3. The National Electrical Contractors' Association symbol, somewhat modified, has been used to represent switches. The enclosing square is used to designate explosion-proof construction.

Fig. 3 shows, in the simplest form, the method of applying the conductor symbols. Only one entry is shown, the parallel entry being omitted for the sake of clearness. It has been suggested that the use of letters to indicate conductors be supplemented by a single

colored or dotted line, which shall extend everywhere that there is any electric wiring. The presence and extent of electric wiring would then be shown by this line, and the specific character and number of the circuits could be learned from the symbols.

This plan seems to have decided advantages. The original method was without the dotted line shown in the suggested method. In Fig. 3 the presence of electric conductors of any sort is indicated

SWITCHES

<i>S.P. S.T.</i>	— [\$] —	\$
<i>S.P. D.T.</i>	— [\$ ²] —	\$ ²
<i>D.P. S.T.</i>	— [2 \$] —	2 \$
<i>D.P. D.T.</i>	— [2 \$ ²] —	2 \$ ²
<i>T.P. S.T.</i>	— [3 \$] —	3 \$
<i>T.P. D.T.</i>	— [3 \$ ²] —	3 \$ ²
<i>A.P. S.T.</i>	— [4 \$] —	4 \$
<i>A.P. D.T.</i>	— [4 \$ ²] —	4 \$ ²
<i>OIL, AUTOMATIC</i>	— [•••] —	⊞
<i>OIL, HAND OPERATED</i>	— [•••] —	⊞
<i>AUTOMATIC TROLLEY</i>	— [□] —	□

by a dotted line, and the specific kind of the conductors is shown by

CONDUCTORS

<i>TROLLEY</i>	— — — — —	T
<i>MEDIUM AND LOW VOLTAGE</i>	— B —	BARE
" " "	— —	INSULATED
" " "	— D —	LEADED
" " "	— E —	ARMORED
<i>HIGH VOLTAGE</i>	— L —	LEADED
" " "	— A —	ARMORED
<i>GROUND</i>	— G —	
<i>SIGNAL</i>	— S —	
<i>TELEPHONE</i>	— P —	
<i>SHOT-FIRING</i>	— H —	
<i>HIGH TENSION LINES ON SURFACE</i>	— — — — —	

FOR DETAIL DRAWINGS

<i>TROLLEY</i>	— — — — —
<i>LOW AND MEDIUM VOLTAGE POWER (EXCEPT TROLLEY)</i>	— — — — —
<i>HIGH VOLTAGE</i>	— — — — —
<i>SIGNAL, TEL., SHOT-FIRING</i>	— — — — —

FIG. 2

NOTE: IN CONJUNCTION WITH THE LETTERS REPRESENTING CONDUCTORS, FIGURES CAN BE USED TO INDICATE THE NUMBER OF SUCH CONDUCTORS WHICH ARE PASSING ANY POINT

the letters in the rectangles alongside of the entry. The letters show that a trolley line, a telephone line, and a signal line all enter the pit's mouth. All these lines follow the main entry as far as the first right entry. The trolley and telephone lines follow the first right entry as far as the first left cross-entry. They turn in there and continue as far as the slant breakthrough, where the telephone line is dropped, the trolley line continuing down the cross-entry. The symbol 2B shows that two bare wires are strung in the breakthrough.

Returning to the main entry, the symbol TP shows that the signal line is dropped just beyond the first cross-entry, but that the trolley and telephone lines continue as far as the symbol T, which shows that beyond this point on the main entry there is nothing but trolley wire. The symbol TP on the first left cross-entry shows that both the trolley and the telephone lines run up this entry.

Fig. 4 shows how the symbols look when applied to an actual mine map. In this case it is necessary to use about 30 of the symbols. It is assumed for the purpose of illustration that the power is taken from an underground substation at which point is installed a 300-kilowatt rotary converter fed by transformers having an aggregate capacity of 350 kilowatts. The symbols show that there is a high-voltage lead-covered cable going down a bore hole to the substation. This cable receives its power from an overhead transmission line and is protected by a lightning arrester. Marginal note No. 3 gives some additional information about this cable. In the underground substation, besides the transformer and the rotary converter, are located a switchboard, a telephone, and 4 incandescent lamps.

The mine is shown with an electrically operated fan. At the fan house the symbols show a high-voltage transmission line and lightning arresters, a 150-horsepower, low-voltage alternating-current motor, a 150-kilowatt transformer, a switchboard, and incan-

descent lights. Marginal note No. 2 gives some additional information regarding the motor.

The symbols show that in pump room No. 1 are located a 50-horsepower direct-current motor of the open type, a switchboard, a telephone, and 4 incandescent lights. There is also a symbol which shows that the return circuit of the motor is grounded to the pipe line leading from the pump.

In pump room No. 2 are located a high-voltage alternating-current motor of 100-horsepower capacity, a switchboard, a telephone, and 4 incandescent lights. There is a high-tension transmission line on the surface which supplies power from a high-voltage leaded cable leading to the pump room through the bore hole and protected by a lightning arrester on the surface. Marginal note No. 4 gives some additional information in regard to the cable.

This mine is supposed to use miscellaneous apparatus; for instance, signal lights are shown at almost every junction of a side entry with the main haulage way. Automatic trolley switches or section insulators with single-pole switches are on every side entry where motors operate. This mine is supposed to use a system by which shots are fired from the surface and the shot-firing lines are carried to the face of all entries. On this particular map the idea of using dotted lines for showing electrical conductors has not been used.

Starting from the hoisting shaft and working toward the inside of the mine, the symbols show that there are two trolley wires, a telephone wire, and a shot-firing line running along the main entry. The second symbol shows that a signal line has been added for operating the signal light in No. 1 North. At the junction of No. 1 North with the main entry the first symbol shows that a trolley line, a signal circuit, a telephone circuit, a bare low-voltage conductor, and a shot-firing circuit are in this entry. The next symbol marks the point where the signal line is dropped. At the entrance to No. 4 West and No. 6 West the symbol 2-BH shows that two bare low-voltage conductors are installed in these entries. The next symbol

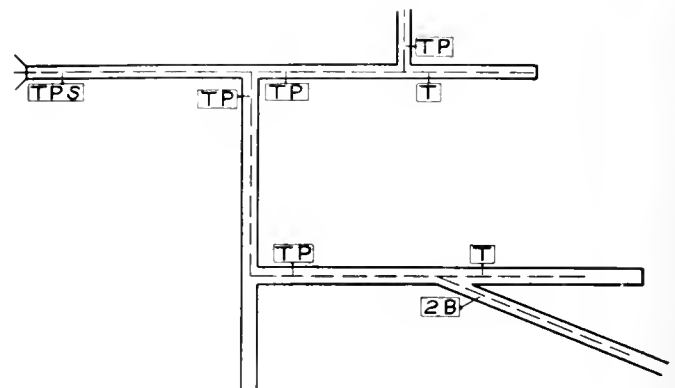

FIG. 3

on No. 1 North, which occurs between No. 6 and No. 7 West, indicates that the signal wire has been picked up. At the entrance to No. 8 West a symbol shows that the trolley wire, a signal line, two bare conductors, and a shot-firing line are carried in this entry. The next symbol shows where the signal line is dropped. The remainder of the conductors are carried in this entry. The next symbol shows where the signal line is dropped. The remainder of the conductors are carried on to the "stop" symbol put outside the last cross-cut

on this entry. The next symbol on No. 1 North indicates the double trolley line at the parting, the signal line for No. 8 West and No. 6 East, a telephone line, a bare feeder, and a shot-firing line. The next symbol shows the dropping of the signal line. Following this there is a symbol which marks the end of the double trolley and the beginning of the signal line for No. 10 West and No. 8 East. Beyond this point *T P B H* marks the end of the signal wire, *T S P B H* indicates the beginning of another signal wire, which in turn is dropped at the next symbol *T P B H* just before reaching the substation. The symbol *T H* shows that both the telephone line and the bare

Deterioration of Coal in Storage

Results of Experiments Showing Effect of Weather on Various Coals Under Different Conditions

By Horace C. Porter and F. K. Oviatt

This article was abstracted from a paper presented at a joint meeting of the New York Sections, American Chemical Society,

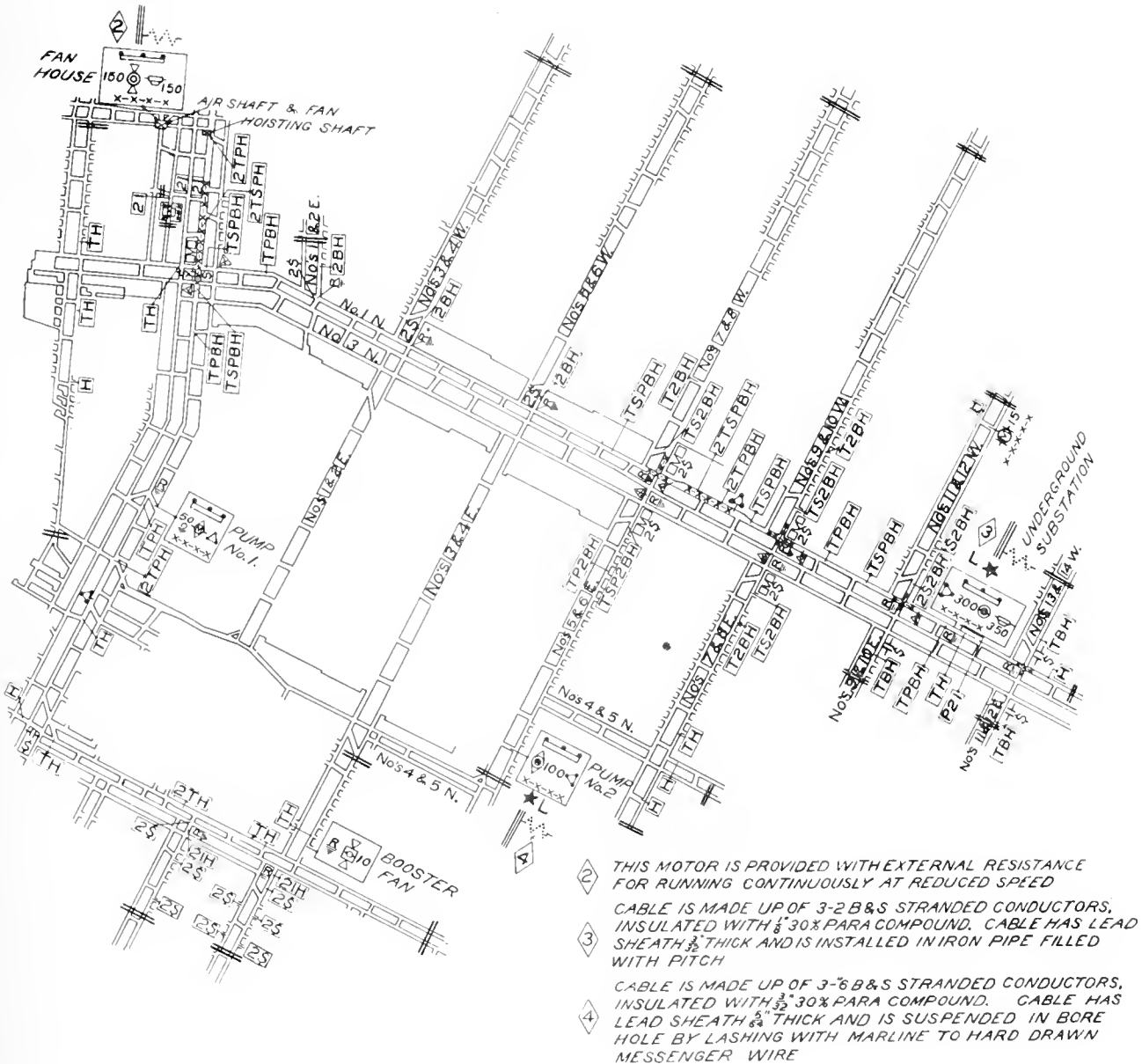

FIG. 4

feeder have been dropped. Just beyond No. 14 West the symbol *H* marks the end of the trolley line, while the shot-firing line is carried to the stop mark near the face.

來 來

Volumetric capacity of a fan is the ratio of the actual volume produced to the cubical contents of the fan multiplied by number of revolutions. The cubical contents of a fan 10 feet diameter, 5 feet wide, is 392 cubic feet, and running at 100 revolutions per minute = 39,200. If we find the actual volume delivered by the fan to be 78,400, we have $78,400 \div 39,200 = 200$ per cent. volumetric capacity.

American Electrochemical Society, and the Society of Chemical Industry, New York, November 10, 1911.

Not many years ago, coal was commonly regarded as an extremely unstable material, subject to very serious alteration and losses on exposure to the elements. E. C. Pechin, in 1872, speaking before the American Institute of Mining Engineers, says: "Fuel suffers materially by storage; especially with bituminous and semi-bituminous coals is the loss heavy, an exposure of only two weeks causing a loss of carbon to the extent of 10 to 25 per cent." Similar views have been held in much more recent times. For example, in a paper before the U. S. Naval Institute in 1906 we find the statement: "The pressure of the weight of coal causes gases to be

evolved; these gases constitute the chief and only value of the coal in that they furnish the heat units. It is claimed that if a ton of fine bituminous coal be spread out on a concrete pavement in the open air in this climate (Key West, Florida) for 1 year, it will lose all its calorific properties. The gases are simply free to escape, and when the coal has lost all its gas it will have lost all its heat units and be simply coke." This was only 5 years ago.

In 1907 a German gas-works engineer claims to have found that moist fine coal sustained an average loss per week of 1.7 per cent., this loss being due to gas. The 1889 edition of Groves & Thorp's *Chemical Technology of Fuels* says: "In some places coal is known to lose 50 per cent. of its heating value in six months." Other statements like these are to be found in recent literature, but probably the great majority of chemists and engineers today hold no such exaggerated ideas on the subject. There is, on the other hand, a well-defined suspicion, in the minds of many that sufficient loss of volatile matter and sufficient deterioration by oxidation does occur in coal to be of industrial importance; and for that reason the investigations described in this paper were undertaken by the Bureau of Mines to determine accurately the extent of the deterioration in different kinds of coal.

First, a study was made in the laboratory of the loss of volatile matter from crushed coal during storage. A number of 20-pound samples representing coal from widely separated fields, were broken to about $\frac{1}{2}$ -inch mesh and immediately placed in glass bottles in the respective mines. At the laboratory the accumulated gas was withdrawn and a free continuous escape of the volatile products permitted at atmospheric pressure and temperature. The results of these experiments have been published in Technical Paper No. 2, Bureau of Mines, entitled "The Escape of Gas from Coal." It was found that while several coals evolve methane in the early period after mining, the coal lost in one year a maximum calorific value of but .16 per cent.

It seems therefore that the loss due to escape of volatile matter from coal has been greatly overestimated.

At the instance of the Navy Department, which stores large lots of coal in warm climates for long periods, more elaborate tests were undertaken to determine the total loss in coal by weathering. The saving to be accomplished by water submergence compared with open-air storage was another point, and the question as to whether salt water possessed any peculiar advantage over fresh water for this purpose was to be settled. An English railway and dock superintendent reported in 1903 that he had found that coal submerged for 10 years in the salt mud of the English Channel, actually improved in calorific value by 1.8 per cent. He claimed that salt will preserve the virtues of coal and that if coal was given a strong dose of coarse salt and water, 12 hours before using, its calorific value was improved.

Coal-storage problems have assumed importance during the last few years on account of the uncertainties of supply due to strikes and transportation difficulties. The naval coaling stations, the Panama Railroad Co., the Great Lakes commercial coal distributing companies, large coke and gas or power plants at a distance from the coal fields, and the railroads themselves, particularly those in the West, keep 50,000 to 500,000 tons in storage much of the time.

In brief outline the tests were carried out as follows: Four kinds of coal were chosen: New River, on account of its large use by the Navy; Pocahontas, as a widely used steaming and coking coal in the East, and as being also the principal fuel used in the Panama canal work; Pittsburg coal, as a type of rich coking and gas coal; and Sheridan, Wyo., subbituminous or "black lignite," a type much used in the West. With the New River coal, 50-pound portions were made up out of one large lot, which had been crushed to $\frac{1}{2}$ -inch size and well mixed. These portions confined in perforated wooden boxes were submerged under sea water at three Navy Yards differing widely from each other in climatic conditions, and 300-pound portions from the same original lot were exposed to the open air, both out of doors and indoors, at the same places.

With the Pocahontas coal, test was made only at one point, the Isthmus of Panama, run-of-mine coal being placed in a 120-ton pile,

exposed to the weather. Pittsburg coal was stored as run of mine in open outdoor bins of 5 tons capacity, at Ann Arbor, Mich., also in 300-pound barrels submerged under fresh water. The Wyoming subbituminous was stored at Sheridan, both as run of mine and slack, in outdoor bins holding three to 6 tons each.

Every test portion was sampled each time in duplicate, and in all cases, except the outdoor pile at Panama and the 300-pound open-air piles of New River coal, the sampling was done by rehandling the entire amount. In the excepted cases mentioned it was not thought fair to disturb the entire lot, and therefore at Panama a vertical section of 10 tons only was removed each time (8 samples being taken from the 10-ton section), while in the case of the outdoor lots at the Navy Yards a number of small portions, well distributed, were taken from each pile, mixed, and quartered down.

Small lots and a fine state of division were conditions purposely adopted with the New River coal so as to make the tests of maximum severity.

Moisture, ash, sulphur, and calorific value determinations, were made on each sample, the latter by means of the Mahler bomb calorimeter and a carefully calibrated Beckman thermometer. The calorimetric work on all except the Sheridan, Wyo., tests, has been done throughout by one man, Mr. Ovitz, and with the same instrument. All the calorific values in the tables have been calculated to a comparable unit basis, viz., that of the actual coal substance free from moisture, sulphur, and corrected ash.

The results show, in the case of the New River coal, less than 1 per cent. loss of calorific value in 1 year by weathering in the open. There was practically no loss at all in the submerged samples and fresh water seemed to "preserve the virtues" of the coal as well as salt. There was almost no slacking of lump in the run-of-mine samples and the crushed coal in all cases deteriorated more rapidly than run of mine.

The Pocahontas run of mine in a 120-ton pile on the Isthmus of Panama lost during one year's outdoor weathering less than .4 per cent. in heating value, and suffered little or no physical deterioration of lumps.

The Pittsburg gas coal during six months outdoor exposure suffered no loss whatever of calorific value, measurable by the calorimetric method used, not even in the upper surface layer of the bins.

The Wyoming coal lost as much as 5.3 per cent. in one of the bins during two and three-quarter years, and 3.5 per cent. even in the first three months. There was bad slacking and crumbling of the lumps on the surface of the piles, but where the surface was fully exposed to the weather this slacking did not penetrate more than 12 to 18 inches in the 2 $\frac{1}{2}$ -year period.

No outdoor weathering tests have been made by the Bureau on coal of the Illinois type. Thorough tests, however, on this type have been reported by Prof. S. W. Parr, of the University of Illinois, and by A. Bement, of Chicago, both of whom find from 1 to 3 per cent. calorific loss in a year by weathering. Mr. Bement reports a slacking of lumps (in tests on small samples) of over 80 per cent. in one case and about 12 per cent. in another. It is probable that in this type as in the Wyoming, the slacking in a large pile would not penetrate far from the surface.

Storage under water unquestionably preserves the heating value and the physical strength of coal. But it practically necessitates firing wet coal, and therefore means the evaporating in the furnace of an amount of moisture varying from 1 per cent. to 15 per cent. according to the kind of coal. This factor is an important drawback to under-water storage with coals like the Illinois and Wyoming types, which mechanically retain 5 to 15 per cent. of water after draining, but in case of the high grade eastern coals, if firemen are permitted, as is ordinarily the case, to wet down their coal before firing, "so as to make," as they say, "a hotter fire," then the addition during storage of the 2 or 3 per cent. moisture which these coals retain would be of little consequence. Submergence storage is an absolute preventative of spontaneous combustion, and on that account alone its use may be justified with some coals, but merely for the sake of the saving to be secured by avoidance of weathering there does not seem to be good ground for its use.

Answers to Examination Questions

Answers to Questions Asked at Examinations for Mine Foremen in Tennessee in 1911

The questions asked in this examination are more practical than theoretical, the object being to gauge the applicant's general knowledge of the mine law and practical mining. There are 72 questions asked, some of which would naturally be answered differently by each applicant, according to his experience. Nine of the first 10 questions are on mine law. A copy of the laws should be obtained from George E. Sylvester, Chief Mine Inspector, Nashville, Tenn.

QUES. 11.—If you had an entry averaging at the place of measuring 6 feet high and $5\frac{1}{2}$ feet wide, and should get an anemometer reading of 684 feet per minute at this point, how many cubic feet of air per minute would you record?

ANS.—Every revolution of the anemometer represents a velocity of 1 foot. The area of the entry is $6 \times 5\frac{1}{2} = 33$ feet, and $33 \times 684 = 22,572$ cubic feet of air passing.

QUES. 12.—In two airways one 7 feet wide and 6 feet high, the other 14 feet wide and 3 feet high, which would pass the greater quantity of air, other conditions being equal, and why?

ANS.—The free movement of air is impeded by its rubbing along the sides of the entries. This resistance called friction increases according to the rubbing surface, but the friction will be less in large than in small areas, because the perimeters, or rubbing surfaces, relative to the areas of the entries are less: thus $7+7+6+6 = 28$ feet rubbing surface for one entry; and $14+14+3+3 = 34$ feet rubbing surface for the other, therefore if the pressure, length, and velocity are the same in both entries, the $14' \times 3'$ entry will pass the most air.

QUES. 13.—What is a water gauge? Explain the construction and how it operates.

ANS.—The water gauge is a glass tube bent in U shape as shown in Fig. 1 with both ends open. One end of the tube is bent at right angles and is fitted with a brass extension tube which is inserted in a small hole bored in the brattice separating two airways as shown in Fig. 2. The purpose of the instrument is to measure the difference in pressure between two airways. Water is poured in the tube and, when there is no difference in pressure, is level in both arms. When the pressure in one airway exceeds that in the other, the water will sink in one arm, the intake, and rise in the other, the return. The difference in levels between the water in the two arms is read on the scale shown in Fig. 1. Any difference in water level as read from the scale on the water gauge represents a ventilating pressure necessary to overcome the friction due to passage of air under conditions prevailing. Each inch of water represents a drag of 5.2 pounds per square foot or a ventilating pressure of 5.2 pounds per square foot. The constant 5.2 is derived from the weight of water, 1 cubic inch of which weighs .036 pound, hence a square foot would exert a pressure of $.036 \times 144 = 5.184$ or practically 5.2 pounds to the square foot.

QUES. 14.—What is meant by splitting the ventilation? What are the advantages of a split in the ventilation? What is the greatest number of men and mules that the law allows to be worked upon any one split?

ANS.—The ventilating current, not "ventilation," is split when different sections of a mine are supplied with certain quantities of the fresh intake air-current for their individual use.

The advantages derived from splitting the ventilating current are increase in volume with the same power, due to decrease in friction resulting from decrease in velocity.

Purer air is supplied, as the return air from one section is not permitted to enter a second section of the mine, but empties into the main return airway. The Tennessee law, Section 32, says: "It shall be unlawful to work more than 50 men and 8 mules in any split or district unless in the judgment of the chief mine inspector it is impracticable to comply with this section."

The following questions have been recently answered in MINES AND MINERALS and are therefore not answered:

QUES. 15.—What are the principal gases that may be found in coal mines? Give common names, chemical names, and symbols.

QUES. 16.—What are the properties of marsh gas? Where found? How detected?

QUES. 17.—What are the properties of carbonic oxide gas? Where found? How detected?

QUES. 18.—What are the properties of carbonic dioxide? Where would you look for this gas? How detected? By what common name is it known among miners.

QUES. 19.—What is known as firedamp?

QUES. 20.—What is known as afterdamp?

QUES. 21.—State the principle of a safety lamp, and why it will not ignite a body of gas.

QUES. 22.—What safety lamp are you most familiar with? Describe same in detail.

QUES. 23.—State in detail what experience you have had with safety lamp, stating where, for how long, and in what capacity you were employed while using same.

QUES. 24.—In going into the mine in the capacity of foreman or gas boss, what would be the first thing you would do after receiving your lamp?

QUES. 25.—How would you proceed upon arriving near the face or place where you suspected there might be gas?

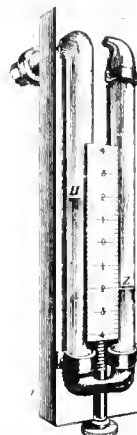

FIG. 1

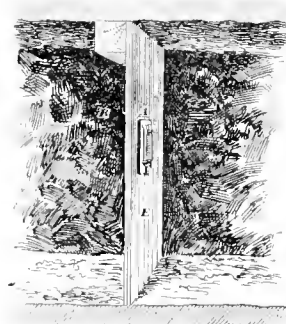

FIG. 2

QUES. 26.—In making test in a considerable body of gas with a Wolf lamp, how would you proceed to keep from getting a "knock-out?"

QUES. 27.—What is the law in a Class A mine in regard to emergency safety lamps?

ANS.—Every Class A mine must keep 25 safety lamps for use in case of emergency and the lamps must be in condition for immediate use.

QUES. 28.—In opening a mine, what do you think is the most essential point to be considered?

ANS.—The position of the openings relative to the tippel that will permit of working nearest to face on up grade.

QUES. 29.—Describe the different methods of producing ventilation in mines that you know of, or are familiar with. What are the advantages and disadvantages of each method?

ANS.—Natural ventilation, where a column of cool fresh air displaces by its weight a column of heated air. Furnace ventilation, which is similar to natural ventilation in principle, but increased by heating the mine air. Mechanical ventilation, either by exhaust or pressure fans. Natural ventilation is practical at small openings where the output would not warrant the expense of a fan. Furnace ventilation has no advantage over mechanical ventilation. Mechanical or fan ventilation produces a more dependable air-current than the furnace, does away with fire in the mine and its attendant risks. The exhaust fan makes the hoisting shaft the intake, the blower or pressure fan makes the hoisting shaft the return, unless special

openings are provided. In some cases one arrangement may be better than the other. The tendency of late years is to use a blower.

QUES. 30.—Name systems of mining you are familiar with, and describe same.

QUES. 31.—In a flat bed mine, what is the advantage of the three-entry system?

ANS.—In the triple entry system, Fig. 3, the middle entry is the haulage road and intake airway, the two outside entries are the return airways and traveling roads for each side of the mine. With this arrangement there is no necessity for the men traveling on the haulage road, the air can be split for each district without trouble, and regulated to conform with the number of men at work in a given district.

QUES. 32.—What is the importance of tight brattices? Why should all the breakthroughs except the last one usually be kept closed, especially in gaseous mines?

ANS.—If a brattice is not tight a considerable quantity of air will be diverted from the direction in which it is intended to go. Breakthroughs should be kept closed in order that the air may reach the working face and not short-circuit.

QUES. 33.—If, in working a room or heading, with face some distance ahead of last breakthrough, you should encounter a considerable feeder or amount of gas, what would you do? Describe in detail.

QUES. 34.—Supposing in this last-named case you should find

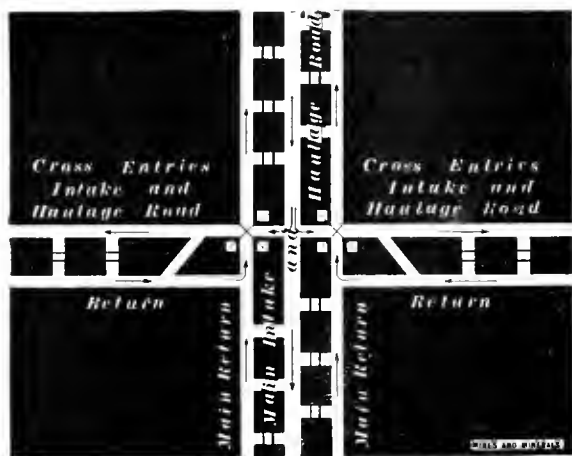

FIG. 3

the flow of gas so strong that the whole heading for a considerable distance back from the face was so full of gas that you could not enter it with a safety lamp, how would you proceed?

ANS. 33 and 34—See Examination Questions in February, 1912, MINES AND MINERALS.

QUES. 35.—Suppose in making gas rounds in a mine known to make gas, before shift went on, you should find a door on a main entry left open by the last shift, which would short-circuit air and leave a considerable part of the mine without ventilation, what would you do? Describe in detail.

ANS.—Put up warning, shut the door and proceed slowly into the workings to see that the ventilating current had been restored and no gas remained. Having satisfied myself that conditions were normal I would remove the danger signal, and try to find the person who had left the door open, at the same time put up a bulletin telling the miners of the danger they incurred through the neglect of some one of them.

QUES. 36.—What would you instruct your miners to do in a gassy mine if they should find a door left open? Give reasons.

ANS.—Instruct them neither to shut the door nor pass it, but report the matter at once. The reasons for this are that some official may purposely have left it open, and if not, the official should precede the miner in seeing that the ventilating current is restored and conditions normal before any one else goes into the district.

QUES. 37.—In setting a prop in a room with hard or sandstone top and bottom, how should you prepare your prop for setting? What kind of cap should you use? Give your reasons for so doing.

ANS.—In setting a prop under the conditions named, I would have both ends squared, the prop a little shorter than the distance between the floor and roof, and drive over it a plank cap tapered so it would wedge. The reasons for this proceeding are:

1. To make the prop perpendicular and so obtain the greatest possible resistance from it.

2. To prevent any sag in the roof which might bring on pressure the prop could not withstand.

3. The prop is unable to support the weight of the entire roof above it, but by the increased area of the plank cap over the area of the prop it can keep a greater area of roof from sagging and working loose.

QUES. 38.—How should you take care of a room with a bad loose and shelly top?

ANS.—Timber close along the track and at the face. If the roof is good above the shelly top it might be advisable to let it fall after the face has advanced. Economical conditions will have weight in a question of this kind, also whether the pillars are to stand or be immediately pulled, as in some mines in the Pittsburg district. In any case with such roof the undercuts should be spragged and timbers kept close as possible to the face, with rooms driven narrow.

QUES. 39.—To protect haulways through a wide place where pressure was so great that props would be insufficient, what would you do? Describe in detail.

ANS.—It might be necessary in this case to use timber sets of three or four pieces, with a post in the middle length of the collar, and then lag over all.

QUES. 40.—What are double timbers, and when or for what should they be used?

ANS.—Double timbering in a mine refers to a leg with a collar resting in a hitch on one side of the entry and on the leg at the other side. Three-stick timbering refers to two legs and a collar, which is sometimes wrongly termed double timbering. Double timbering is used on entries where there is danger of some part of the entry roof giving way and a prop cannot be set directly under the weak spot on account of being in the way.

QUES. 41.—In a gaseous mine, would it be a safe proposition to brattice the worked-out territory entirely off from your circulation? Explain fully what you would do.

ANS.—In all probability it would not be safe, as gas might accumulate under pressure and find its way into the mine. Further, when there is little or no ventilation gob fires are apt to occur, and under certain conditions such fires would cause an explosion or their intensity would be increased by gas igniting. While the abandoned territory should be sealed off it should be ventilated by a separate current behind the air stoppings and passing directly to the main return airway.

QUES. 42.—What is an overcast? For what purpose is it used?

ANS.—An overcast is an airway constructed over an entry, for the purpose of carrying the fresh air to a certain part of the mine before it is discharged into the return.

QUES. 43.—What is the use of doors in a mine? What are the principal essentials for a good mine door?

ANS.—To prevent air short circuiting or to force it to go into a definite part of the workings where it is needed. The essentials for a mine door are strength, tightness, and good hinges; that it be hung so it can be opened readily against the air and closed tight without too much jar. The door posts or jambs and their proper setting and anchoring are extremely essential to a good mine door.

QUES. 44.—When it is necessary to control the air circulation by doors on the main haulway, how can you arrange same to keep from short circuiting air during passage of trips through door?

ANS.—If this is absolutely necessary double doors are adopted and one opened after the other is closed.

QUES. 45.—When can curtains be advantageously used, instead of doors?

ANS.—When it is desired to send a temporary air-current up a room on airways not much used for traveling.

QUES. 46.—When is it necessary to have trappers at doors?

ANS.—When doors are required on main haulways. It is possible in many cases by additional first cost to do away with doors and trappers. Usually this course is economical in the end and much safer.

QUES. 47.—What kinds of mechanical haulage do you know of that are now used in coal mines?

ANS.—Endless rope, tail-rope, engine plane, self-acting or gravity plane, compressed air locomotives, electric locomotives, gasoline locomotives and occasionally steam locomotives.

QUES. 48.—State what you consider the dangers, if any, of each kind of haulage? What precautions would you take in the installation and operation of each kind to make each as safe as possible to the miner?

ANS.—Danger from the ropes and riding on the cars. Danger from crossing over a rope haulage. Locomotives are not dangerous to miners if the miners keep off the haulways. Electric haulage should have the trolley wire housed at crossings where men or animals are apt to come in contact with it.

QUES. 49.—What precautions should you use in a mine which generated gas, and in which electric haulage was used?

ANS.—Make the intake the haulage road. Use encased motors; at the same time keep them out of the danger zone.

QUES. 50.—What is the law in regard to men riding a loaded trip? What would be your policy as mine foreman in regard to same?

ANS.—Unless hired for the purpose, it is against the law, Section 33, and subject to a \$25 fine. Have him fined.

QUES. 51.—What is a blown-out or windy shot?

ANS.—A shot not properly placed that has blown out tamping and not broken down the coal.

QUES. 52.—How are they caused?

ANS.—By being wrongly pointed or too little powder used.

QUES. 53.—What are their dangers?

ANS.—Setting fire to gas or dust.

QUES. 54.—What precaution would you take to avoid them as much as possible?

ANS.—Watch a new miner and see how he points his holes. Instruct him, if he lacks experience, or else have some one point the holes. In some mines the boss instructs the miners on pointing and loading, particularly in mines where shot firers are required.

QUES. 55.—What are known as permissible explosives?

ANS.—Explosives which have been tested by the United States Bureau of Mines and have been found to be less dangerous in flaming than "black powder." Every explosive, if fired in large quantities, will cause ignition of gas, therefore an arbitrary charge of 1½ pounds is established as the quantity used in making tests. Permissible explosives when fired give a low flame temperature compared with that of black powder.

QUES. 56.—Which is the most dangerous time of year in a dry mine, winter or summer, and why?

ANS.—Winter, because the air entering the mine abstracts moisture from the coal in some cases.

QUES. 57.—What precautions would you take in case you found your mine beginning to be dry and dusty?

ANS.—Turn steam in the intake and sprinkle the road beds in a very soft coal; and cover the haulways with fireclay or loam in case of a pitchy coal, leaving out the sprinkling but using some steam.

QUES. 58.—On your inspection of a man's room before he went to work, if you should find a bad roof, what would you do?

ANS.—Have it taken down or propped before any work was done.

QUES. 59.—What is known as a creep in a coal mine?

ANS.—The floor is generally soft and pushed up into the excavations by the weight of the rocks above.

Book Review

HEATON'S ANNUAL for 1912 is the Commercial Handbook of Canada and Boards of Trade Register. The book is used by the Canadian government officials and British consuls, as it is the standard authority upon the Canadian customs tariff law and regulations. It contains about everything a business or professional man wants to know including the most complete summary of the resources of the Dominion and a Gazetteer of Towns, invaluable as a guide to manufacturers and commercial travelers. The Annual is the official Register of the Canadian Boards of Trade and contains the requirements of all professions in each province. A new feature in the 1912 volume is a list of insurance companies licensed to carry on business by the Dominion and Provincial governments. The book can be obtained for \$1.12 from Heaton's Agency, 32 Church St., Toronto, Canada.

STAMP MILLING is the name of a treatise on practical stamp milling and stamp mill construction, by Algernon Del Mar. It contains 129 8vo pages, 98 illustrations and index. The book is divided into seven chapters.

Probably one of the best ways to give the seeker after knowledge an idea of the author's knowledge of his subject is to quote some of his remarks. For this reason Chapter III, "Practical Working of the Stamp Mill," is taken. "The time expended in doing a good job will be repaid in the gain in running time. The five factors, weight of stamp, height of drop, number of drops per minute, character of screen and height of discharge should be so correlated as to produce the best results on the ore under treatment. As the maximum height of the drop is fixed by the shape of the cam this should have been determined before the mill was ordered. The height of discharge is perhaps the most difficult factor to determine. Cam-shaft collars loosen by vibration of the cam-shaft. The remedy is to line up the shaft, thus reducing the vibrations to a minimum. Cam-shafts sometimes crystallize or change structure so that they break. Broken stems should be annealed before being used again to correct any crystallization remaining near the broken end. Bosses or boss-heads come off because the drop is either too high for the speed, causing camming, or too low for the style of cam, causing a series of blows which may force the stem out of the socket of the boss. Shoes come off from too much play in the guides, too much ore in the mortar, or from the pounding of the shoe on the die. Dies seldom become misplaced unless they are worn down to near the discarding point and should then be tightly wedged with iron or wooden wedges. Steel cams seldom break, the only cause being by camming due to a loose tappet, a shoe off, a boss off, or a runaway of the engine. Tappets usually slip from the stem having worn too small for the gib to hold. Any millman that cannot set his tappets from the cam-shaft floor had better be given his time."

The price of this book is \$2 and should be in the hands of every practical millman. It is published by the McGraw-Hill Book Co., New York, N. Y.

THE AUTOBIOGRAPHY OF JOHN FRITZ, by John Fritz. This book, which contains 327 8vo pages, is illustrated with full-page half tones. It is printed by John Wiley & Sons, New York, N. Y. Price, \$2. The book is dedicated to "the loyal, able, brave, and fearless men who so faithfully stood by me throughout my career." In the preface Mr. Fritz tells how he came to write the book. "My undertaking came about wholly through the persistent urging of a number of old friends, who insisted on my writing out for them in my own words an account of my life struggles; and the publication of my autobiography before my death is again owing to the fact that, against my wishes, these good friends would not wait for it, but insisted on having it now. So I have jotted down the record of my life and it is given to you as I wrote it. You must not expect fine language nor eloquent periods, but only the honest record of the hard working life of one who loves his country and his fellow men and who has tried to serve both." There are 28 chapters in the book, also forewords by Robert W. Hunt, Axel Sahlin, D. A. Tompkins, and John Alfred Brashear.

John Fritz was born August 21, 1822, in Londonderry Township, Chester County, Pa. His parents, who were Germans, landed in Philadelphia, August 26, 1802. Mr. Fritz's more than 89 years have covered the most eventful era in the world's history, in fact it is hard to realize that any life could have witnessed so many and such wonderful achievements. In Mr. Fritz's own particular field of engineering he witnessed the discovery, and participated in the development, of the epoch-making Bessemer process, followed by the acid and basic open-hearth processes, and besides those other tremendous developments in the iron and steel arts in which he was an active factor.

MODERN ASSAYING, a book containing 145 pages, 115 illustrations and 21 chapters, is a concise treatise describing the latest methods and appliances of modern fire assaying and some volumetric assaying, by J. Reginald Smith. The book is published by the J. B. Lippincott Co., Philadelphia, Pa., and London, Eng. The price is \$1.50, and it is edited by F. W. Braun. Unfortunately there is no index and one has to depend upon the Table of Contents for any particular subject which he desires to find. This method of preparing a book is objectionable to the busy man. Specially interesting material is found in the following chapters: Chapter IX describes the Touch Stone and Test Needles; Chapter X, Volumetric Determination of Copper with Solution of Potassium Cyanide; Chapter XI deals with the Modification of Keri's Swedish Copper Assays; Chapter XII, Electrolytic Assaying with the Guess-Haultain Electrolytic Outfit; Chapter XIII, Wet Assays of Lead; Chapter XIV, Volumetric Determination of Lead by the Molybdate Method; Chapter XV, Distilled Water; Chapter XVI, Mercury Determination by Distillation; Chapter XVII, Whitton's Method of Mercury Determination. There are some new features in this book which have not appeared in others.

MINERALOGY, by F. H. Hatch, Fourth Edition, entirely rewritten and enlarged, with 124 illustrations and 241 pages with index. The MacMillan Co., 66 Fifth Ave., New York, N. Y., are the publishers. The price is \$1.40 net. Whittaker & Co., 2 White Hart St., Paternoster Square, London, E. C., are the English publishers. The book is divided into two parts, The Properties of Minerals, and Descriptive Mineralogy. The first edition of the book was published in 1892. This appears to be a useful little book, as it takes up minerals first giving their chemical formulas, then the crystallization, streak, color, luster, hardness, density, fusibility, and solubility. In some cases wet tests are given and in others they are lacking.

BUSINESS PROSPECTS YEAR BOOK FOR 1912, by the Business Statistics Co., Ltd., 12 James St., Cardiff, or 20 Victoria St., S. W., London. This book is edited by Joseph Davies and C. P. Hailey, and tells what will happen to coal, iron, copper, tin, tin plates, oil, shipping, rails, wheat, cotton, rubber, hog products and dairy produce. The price is 5s., net. In all sections of commerce and finance success is synonymous with foresight. The mine owner, the manufacturer, the merchant, the middleman has, if his business career is to be successful, to take into consideration events which have taken place in all parts of the world, form a judgment of the course of markets, and act upon the same even at the risk of having events turn out quite differently. The book contains a large amount of statistical information on the subjects already mentioned, and should appeal to those engaged in commercial pursuits of this kind.

TYPES OF ORE DEPOSITS is the name of a book published by the Mining and Scientific Press, San Francisco, Cal., and the Mining Magazine, 819 Salisbury House, London, E. C. It contains 378 pages, indexed and illustrated. The price is \$2. The book is not by any one particular author, but contains chapters on different ore deposits by men who have made studies of them. The Clinton Type of Iron Ore Deposits is written by C. H. Smyth, Jr. The Lake Superior Type of Iron Ore Deposits is by C. K. Leith, a man who has devoted a number of years to their study; Flats and Pitches of the Wisconsin Lead and Zinc District, by H. Foster Bain, who was geologist in that section of the country for a number of years; Lead and Zinc Deposits of the Ozark Region, by E. R. Buckley, well known as a geologist and mining engineer, who was located for some time at Rolla, Mo.; Native Copper Deposits, by Alfred C.

Lane, a well-known geologist of Tufts College; Cobalt District, Ontario, by S. F. Emmons; Geology at Treadwell Mines, by Oscar H. Hershey; the Saddle Reef, by T. A. Rickard, who spent considerable time in Bendigo; Contact Deposits, by James F. Kemp, professor at Columbia, and author of Kemp's Ore Deposits; The Conglomerates of the Witwatersrand, by F. H. Hatch; Replacement Ore Bodies and the Criteria by Means of Which They May Be Recognized, by J. D. Irving; Outcrop of Ore Bodies, by William H. Emmons; Some Causes of Ore Shoots, by R. A. F. Penrose, Jr. This galaxy of geologists, writing as they do on special subjects, should say something which has particular bearing on the subjects upon which they write. Mr. Lane's discussion of Native Copper Deposits, and Mr. Irving's of Replacement Ore Bodies were read before the Canadian Mining Institute last winter. Mr. Hershey's paper on the Treadwell Deposits, that of S. F. Emmons on Cobalt, and of W. H. Emmons on Outcrop of Ore Bodies are reproduced from the *Mining and Scientific Press*. The remaining chapters were written for this book from material previously printed in the Transactions of the American Institute of Mining Engineers, and from the reports of the United States Geological Survey and the State Geological Surveys. The compilation together with the various writings should make this one of the most valuable books on ore deposits.

THE ANNUAL REPORT OF THE BOARD OF REGENTS OF THE SMITHSONIAN INSTITUTION FOR 1910 has been received and seems to lack nothing of the high class of former volumes. It covers a variety of subjects which are splendidly illustrated. Among the various papers in the general appendix those that appear to have any bearing whatever upon the mining industry are as follows: Progress in Reclamation of Arid Lands in the Western United States, by F. H. Newell; Some Modern Developments in Methods of Testing Explosives, by Charles E. Munroe; Forest Preservation, by Henry S. Graves; Biography of Alexander Agassiz; Cave Dwellings of the Old and New Worlds, by J. Walter Fewkes. There are a number of articles which will appeal to nearly every kind of profession, among them are Aviation, Precision Measurements of the Ion, The Solar Constant of Radiation, Astrophysics, A Review of Current Research in Isostasy, and The Sacred Ear Flower of the Aztecs.

MINE ACCIDENTS AND THEIR PREVENTION. This is a book of instruction for mine workers especially adapted for teaching English to foreign mine workers. It was prepared by J. H. Dague and S. J. Phillips, secretaries for the education of mine workers, Young Men's Christian Association of Scranton, under the direction of R. A. Phillips, manager, and C. E. Tobey, superintendent, of the coal mining department of the D., L. & W. Ry., and is published by the department. The purpose of the book is to familiarize mine workers with safe methods of mining anthracite; to give a knowledge of colloquial English to non-English speaking mine workers that they may understand orders and thus be better able to protect themselves against the dangers of the mine. Dr. Peter Roberts' plan of teaching English, which was explained in August, 1910, *MINES AND MINERALS*, is followed, with 200 excellent illustrations from photographs taken by W. B. Bunnell, official photographer of the company. Each page is an illustrated lesson and in all there are 62. The wrong way of doing things is shown first, followed by the right way on the opposite page, thus the two are pictorially compared. The following are some of the subjects treated: Failure to examine roof after a shot; knocking out a prop with a hammer; props knocked out with a shot; working under bad roof; miner leaving chamber unsafe; drivers and their dangers; motorman and his dangers; dangers from runaway cars; trappers and their dangers; dangers from shot firing; thawing dynamite; crossing over trip of cars; danger from electric wires; danger on cages; careless workmen; naked lamp in gassy chamber; safety lamp in gassy chamber. There are also a few pages by W. J. Torrey, Esq., on how to become a citizen of the United States. Those miners who receive this book cannot but be helped by examining the illustrations. It is our belief that Colonel Phillips has by this plan done a great service to the miner whether he is English speaking or not. The book is to be printed in several languages we are informed.

Coal Developments at Stearns, Ky.

Use of an Aerial Tramway to Transport Coal Across a River Description of Equipment and Surface Arrangements

By J. E. Butler*

The following is an abstract of a paper read before the Kentucky Mining Institute at Lexington, Ky., December 11, 1911:

No attempt is made in this paper to instruct in the methods of mining, how to conduct a coal-mine operation, or to offer any panacea for the ills of the coal operator. If, however, any operator here delights in dwelling upon the details of each particular malady I shall gladly retire with him to the sewing circle of my acquaintance, and there depict, with the vividness born of personal experience, the horrors of the mining epidemics known as "chain machines and electric drills in high sulphur coal," "local power plants," "mining by day labor," Janey couplers for mine cars, gas and dust explosions, mine fires, strikes, and other contagious diseases of mining.

Stearns is a town on the Cincinnati Southern Railroad, 190 miles south of Cincinnati, Ohio, and 144 miles north of Chattanooga, Tenn. Here are located the offices of the Stearns Coal Co., Ltd., the Kentucky and Tennessee Railway, and other companies owned by the Stearns people. There are no expensive shafts, no spectacular surface work, not even an incline to relieve the monotony of a plain coal-mining town and belie the assertion of Mark Twain that a mine is a hole in the ground and its owner a liar.

The property consists of approximately 85,000 acres of coal and timber land lying adjacent to the South Fork of the Cumberland River, in Whitley, Wayne, and Pulaski counties, Ky., and in Scott, Pickett, and Fentress counties, Tenn. The coal seams, three in number, occur in the Lee conglomerate. They are the lowest in the Carboniferous series and are designated locally as 1, 2, and 3. Seams 1 and 2 are being developed. In thickness they are quite irregular with extremes of 2½ feet and 7 feet, averaging between 4 and 5 feet. The coal may be described as a very hard domestic and steam coal with excellent gas and coking possibilities. The following approximate analysis of the No. 1 seam will give some idea of its quality.

	Per Cent.
Moisture.....	3
Volatile matter....	35
Fixed carbon.....	57
Ash.....	5
Total.....	100
Sulphur.....	.73

railroad starting considerably higher than the top seam, intersecting the seams successively as it descends the valley of the South Fork of the Cumberland River.

The first mine was opened in 1903, at Barthwell, Ky. Since then two more have been started at Worley and Yamacraw, with a capacity of 3,000 tons in 9 hours, and an actual production of 2,000 tons daily. For the purpose of furnishing electrical power to the mine, a central power station was erected at the sawmill at Stearns, permitting the use of sawdust as fuel when the mill is



FIG. 2. LOADING CARS FROM TRAMWAY

running. Here a 450-kilowatt, 40-cycle, three-phase, General Electric, alternating-current generator produces a current which is stepped up to 13,000 volts for the high-tension transmission line which delivers current to the substations at the mines, where it is stepped down to 575 volts, for driving fans, pumps, air compressor, and the direct-current generators, which furnish current for motor haulage and for chain coal cutters. This plant is inadequate for the rapidly growing business, and the company is now planning to erect a new and larger one at Yamacraw of not less than 1,000 horse-power capacity.

Among the developments of the past year was the installation of the motor haulage on the main entries in mine No. 4. Gathering with locomotives was not successful owing to the many irregularities in thickness of the bed and so many local raises and swags. The combination of mules and motors was tried and worked well. Previous to introducing electric haulage, track grades were reduced, roads were straightened and easy curves put in, and track relaid with 25- and 35-pound steel rails on white oak ties, 5 in. x 6 in. x 5½ ft., spaced at 18-inch centers. A compressed-terminal bond, consisting of a head on the end of a copper conductor, was used. This head is compressed in a drill hole in the rail by means of a screw jack which exerts a pressure of from 10 to 20 tons on the head of the bond, causing the copper to expand in the hole and form an intimate contact. These bonds have thus far eliminated the troubles arising from poor bond contacts. The trolley wire is 4-0 V grooved. The machine wire is No. 4. The clamps are the "sure grip."

Power is obtained from a Jeffrey 150-kilowatt generator, to which is directly connected an induction motor, forming a motor-generator set. The three haulage motors were made by the Jeffrey company.

Recently No. 11 mine was opened at Yamacraw on the west bank of the South Fork of the Cumberland River. As the railroad is on the east bank it became necessary to provide means for transporting the coal across the river temporarily for the development and construction period, and later for the regular operation of the mine. Temporarily an old steam hoist was set up near the railroad, and a 1¼-inch plow-steel cable was strung across the river and anchored in solid rock on either side. On this was suspended from a trolley a sheet-iron bucket of 2 tons capacity. The coal is dumped from the mine car through a short chute directly into the bucket, pulled across the river by means of the steam hoist, dropped



FIG. 1. LOADING STATION AT MINE

The coal outcrops at tippie height above the railroad track. It may be explained that this is not due to chance. In planning the railroad it was arranged that the elevation of the main line should be approximately 34 feet below the coal beds where it was convenient to open mines. This was possible on account of the

* General Manager.

into a chute leading to the railway cars, and shipped as run-of-mine. With this equipment 150 tons of coal was loaded in 9 hours at a cost not to exceed 10 cents per ton, and the wasteful practice of stacking the development coal in the mine yard was avoided. At the time the permanent equipment was ready for use on November 1, forty rooms were ready for the miners and not a ton of coal was lying around anywhere within 30 days after the mine was put in operation.

The permanent equipment consists of an aerial tramway of 550-foot clear span operated by a 35-horsepower General Electric variable speed motor, geared to the main driving wheel of the tramway. The 1½-inch lock-coil track-ropes cables reach from cliff to cliff across the river, and are anchored in solid rock and concrete. The traction cables are ½-inch plow steel. The buckets are 52 cubic feet capacity and travel at a speed of 800 feet per minute. Fig. 1 gives an idea of the loading station at the mine and Fig. 2 the tippie at the tracks although not finished.

The present capacity of the tramway, which requires the services of one man to operate, is 500 tons in 9 hours and consumes from 20 to 28 horsepower.

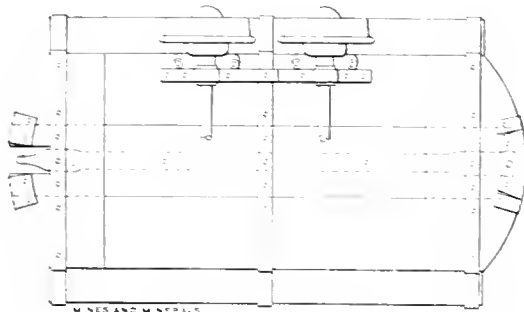
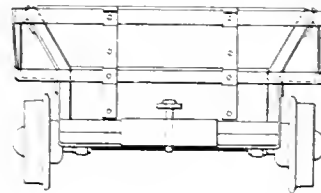
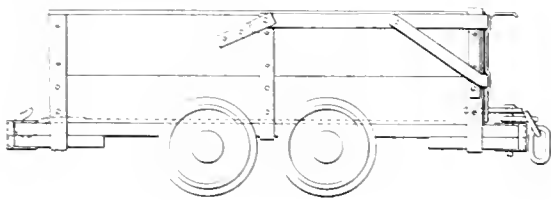

FIG. 3. CAR ADOPTED AT MINE NO. 11

The coal is dumped from the mine cars over a Phillips automatic kick-back tip on to the ridge of a 60-ton capacity storage bin built in the shape of the letter W. The buckets are alternately loaded through undercut gates at the bottom of the bin. At the tippie the bucket-door latches are automatically tripped and the coal discharged on to shaker screens, designed for four grades of coal at any given time, but several combinations of grades may be obtained by the opening and closing of valves in the main pan, without stopping the screens. The screens are operated at 120 revolutions per minute by means of a 12-horsepower induction motor.

The horns of the loading tippie being but 100 feet from the mine mouth, it was necessary to extend the sidings into the mine. The track grades were arranged so that 200 feet of 1.5-per-cent. grade is in favor of the hoists and a corresponding 200 feet of 1½-per-cent. grade in favor of the cars returning to the mine through a second entry. With satisfactory grades, with roller-bearing wheel cars and with the aid of the automatic tip, one man has weighed and tipped 150 tons of coal in 9 hours.

The mine is worked on the room-and-pillar system. A main entry and drifts are driven into the mountain. From them secondary entries are driven to the right and left in 400-foot centers. Fifty of these 24-foot rooms are mined in 40-foot centers. With slight alterations the plans are followed in all of the Stearns mines.

In selecting a hauler for this new operation it was the intention to obtain as far as possible the best available features of the best haulers in use, the Sandford-Day roller-bearing wheels and the best type for the self-loading type, reducing the cost for oil

and labor materially, and the car resistance by 50 per cent. The center bumper, Fig. 3, was substituted for the corner bumper, greatly reducing the repair bills, owing to the wrecking due to "bumpering" and interlocking of bumpers. The hook-and-link coupling was retained, by making a slot 4½ inches wide in the rear bumper for the hook. Harris hitchings replaced the ordinary welded chain couplings, eliminating the annoyance of broken couplings. Double clips for tripping the car doors were substituted for the single center clip, causing the door, when the car is dumped, to lift vertically and prevent door irons being twisted. The size and weight of the car also was kept within the bounds where one man could handle it, either loaded or empty, on reasonable grades.

All shots are fired by two specially appointed shot lighters after all others are out of the mine. The miners pay for one of these and the company pays the other.



Manufacture of Explosives in 1909

The preliminary report of the Census Bureau on the manufacture of explosives in 1909, has been published by the Department of Commerce and Labor, Washington, D. C. The tabular summaries are interesting, because the greater part of the explosives are used in mining enterprises.

Comparative summaries follow, giving the general statistics for the industry and the different products by kind and quantity, 1909 and 1904

EXPLOSIVES—GENERAL SUMMARY: 1909 AND 1904

	Census		Per Cent. of Increase 1904-1909
	1909	1904	
Number of establishments	86	124	*31
Capital	\$50,168,000	\$42,307,000	19
Cost of materials	\$22,812,000	\$17,204,000	33
Salaries and wages	\$ 5,438,000	\$ 5,106,000	6
Salaries	\$ 1,134,000	\$ 1,797,000	*37
Wages	\$ 4,304,000	\$ 3,309,000	30
Miscellaneous expenses	\$ 3,211,000	\$ 1,658,000	94
Value of products	\$40,140,000	\$29,603,000	36
Value added by manufacture, products less cost of materials	\$17,328,000	\$12,399,000	40
Employees:			
Number of salaried officials and clerks	763	1,289	*41
Average number of wage earners employed during the year	6,274	5,800	8
Primary horsepower	28,601	29,665	*4

* Decrease.

EXPLOSIVES—PRODUCTS BY KIND AND QUANTITY: 1909 AND 1904

	Census		Per Cent. of Increase, 1904-1909
	1909	1904	
Dynamite, pounds	177,153,851	130,920,829	35
Nitroglycerine, pounds	28,913,253	7,935,936	264
Blasting powder, kegs (25 pounds)	9,339,087	8,217,448	14
Gunpowder, pounds	12,862,700	10,383,944	24
Permissible explosives, pounds	9,607,448	(†)	
Other explosives, pounds	7,464,825	6,303,825	18

* In addition, in 1909, 1,700,398 pounds, and in 1904, 1,104,532 pounds of "other explosives" were made by Federal establishments and by establishments engaged primarily in the manufacture of other products.

† Not reported.

‡ Includes gun-cotton and smokeless powder.



Consul General John P. Bray, of Sydney, Australia, reports that experiments recently made in the iron works at Lithgow with certain ore taken from the Mudgee district of New South Wales, have proved extremely satisfactory, the ore averaging 42 per cent. pure iron. The quality is so good that the owners of the works have made application to the railroad for a daily train to convey the ore to Lithgow. It is stated that there is sufficient ore in sight to keep the Lithgow works going for years.

ORE MINING AND METALLURGY

Limonite Prospecting and Mining

Large Deposits of Ore in Virginia Mined by Open-Cut With Steam Shovels and Also by Underground Work

By Charlton Dixon, Mine Manager*

This article deals with brown hematite prospecting and open cut mining as practiced in Alleghany and Craig counties, Virginia. The districts embraced in these counties are popularly known as the Rich Patch and Potts Valley districts, and it is from them the Low Moor Iron Furnace, shown in Fig. 1, obtains its ore supply. Mining in these districts commenced early in 1800 and continued to the Civil War, with more or less regularity, for the purpose of supplying small charcoal furnaces with iron ore. After war times the ore beds formed one incentive for the construction and operation of the Low Moor iron furnace, the other incentive being the New River, W. Va., coking coal beds. Mining in the early days consisted in taking the best and cheapest ore wherever found on or close to the surface. When the overburden of waste threatened to increase the cost of producing ore at an opening it was abandoned and another commenced. Many of the open cuts furnished thousands of tons of ore with practically no expense save the actual cost of blasting, loading, and haulage. There were no stripping, timbering, or pumping expenses, as the ore stood perpendicular for several hundred feet in length and from 30 to 60 feet in width.

There are profitable open cuts today, but nearly four years' experience failed to disclose anything to compare with the old openings as regards quality, with but one or two exceptions. At the largest operation in the field, where all the ore is obtained from surface workings, it is necessary to run it through the washer to obtain a percentage of iron several points inferior to the product direct from the old mines worked years ago.

The policy today is to mine at the surface as long as possible, yet the underground product is cheaper in nearly every case, at the year's end. The quality being the same, that from underground is always the better on account of less waste being shipped with it to the washer, due to more careful mining invariably practiced inside. The greater cost of explosives, narrow work and timber is offset by having less waste to handle and ability to work independent of the weather.

It does not pay to carry on surface mining during January and February, but to prevent the disintegration of the organization it

*Pittsburg, Pa.

is practiced. In addition to the above, when attempting any underground mining and especially in the first thing is to examine an untouched vein thoroughly for an outcrop. As probably less than 10 per cent. of the deposit is horizontal it is only a matter of climbing the mountain side to where the black-slate capping rock (Alleghany) outcrops. This does not always lead a prospector to ore, but will without fail take him where it should be according to the geological formation shown in Fig. 2. On account of talus and wash dirt on the hillside careful examination may fail to discover even float. Under these conditions the ore is sought by narrow drifts through the loose earth, shale, and cap rock, as shown in Fig. 2. Such drifts, only wide enough for a wheelbarrow, are arched nicely but not numbered. If no ore is found another drift is driven about 50 feet below the first. A study of the ground disclosed in the drifts decides whether mining will be prosecuted with pick and shovel and whether further prospecting shall be carried on by portable drilling machines of the Star and Hepstone



FIG. 1. LOW MOOR IRON FURNACE

type. Comparisons made between hand work and machine prospecting favor the latter in speed, and results are in general more satisfactory. When using machines it is customary to follow the outcrop of the shale using the magnetic course N 45° E or S 45° W as a guide because of its being the strike of the mountain system and because it is generally the strike of most iron ore deposits in the Appalachian mountains. The float ore on the surface is also used as an indicator provided the outcrop is covered or other indications are obliterated.

A line of holes 50 feet apart is then drilled as far as desired, a hole and one 50 feet below the first, the holes being staggered in order to sample the ground between. This is followed out to the bottom of the hill, and then the drill is taken to the opposite hill, where the same routine is followed. Sometimes the holes are only drilled to a depth of 60 feet for two reasons: First, if ore is found at that depth of sufficient thickness that the stripping will not exceed 241 over sufficient area, it will be open-cut work; should the reverse prove true it means an underground operation. Second, it shows where waste may and may not be dumped. By not paying proper attention to the dumping ground good ore has been covered with waste that later had to be removed at considerable expense. Usually a thorough survey is made of the ground to be prospecting, and the area is divided into 50-foot squares, staggered like a checker board, staked at each intersection and numbered consecutively.

The hole when drilled takes the stake number. The drill cuttings from each hole that is in ore are analyzed for iron and manganese. The drill hole furnishes all the information required; namely, depth of cover, thickness, and quality of the ore, and dip of the bed, besides being suggestive of the best system of extraction

under the circumstances. The most convenient places to deposit the overburden are now selected, usually the steepest slopes in the vicinity. Two dumps are nearly always used where a steam shovel is employed. The track is of steel rails up to 65 pounds with standard 4-foot 8½-inch gauge. Anything lighter than this equipment will be troublesome where 4-cubic-yard cars and 14-ton locomotives are used. During rainy weather the dump piles sink and slip, and even with heavy road bed equipment it is almost impossible to maintain the tracks in proper condition to guarantee the steady operation of shovel, locomotives, and crews.

The 65-ton steam shovel was used in the heaviest stripping proposition ever attempted in this vicinity and gave perfect satisfaction.

When provision for the disposition of the overburden has been made, the shovel is started at a point where a sloping cut of not more than 6 per cent. will reach the bottom of the ore at the most

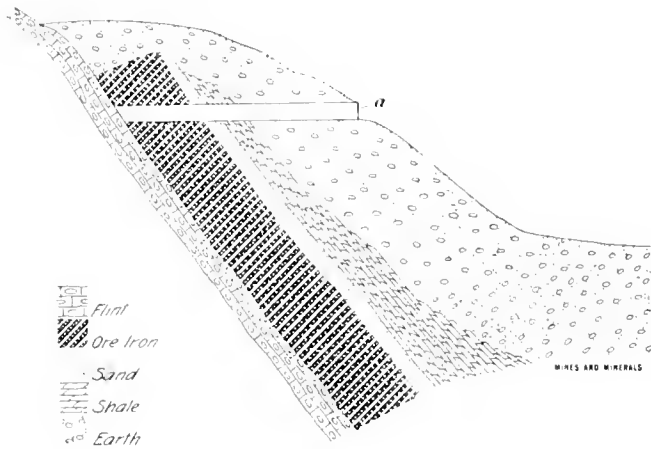

FIG. 2

convenient spot. This grade is carried down until the maximum depth is attained at which the cars can be loaded, and then this level is maintained to the boundary of the workable ore, the loading being on the most convenient side of the cut. The first trench, known as the "through cut," having been made, the shovel is brought back to the bottom of the slope and a side cut taken, the loading track being now laid in the trench. The side cutting is continued until the boundary is reached when another through cut is commenced and the slope followed down until the loading capacity of the boom is reached, after which the former process is repeated. Convenient sidetracks are laid which enable the empty trip to come in behind the one being loaded, so that there may be the least delay possible to the shovel. This exceedingly important point is one upon which too much stress cannot be laid. A good track gang is always in attendance with several track jacks and plenty of old car plank to level up the track when necessary.

The above described operation is continued until the capping rock is reached. At this stage some really difficult and costly work must be done. One reading description of strip-

ping done by these monstrous machines is apt to imagine them forcing their way through all obstacles. It is not so in practice, and it is surprising what a small ledge *in situ* will paralyze them completely. The capping rock is irregular; and when stripped by hand, rocky hummocks project here and there in the line of projected work. The fire and dust following the contact of the manganese steel teeth of the buckets with the Oriskany sandstone are a warning that any impression made will be at the expense of chain or gearing. If one of these rocky hummocks is uncovered early in the morning a steam drill is set up and connected with a locomotive or the steam-shovel boiler. Then the necessary holes are drilled and the obstacle blasted from the path. In the meantime the shovel and "dinkey" crews are assiduously doing nothing except holding a piece of waste, a habit which seems indigenous to their relative positions as higher paid artisans, and which interpreted means "must not apply me elsewhere." This condition of affairs may continue several weeks, today working on waste, tomorrow on capping rock and ore.

It is very slow and expensive. Invariably after all possible has been removed by the machine there remain scores of tons to be dug out of the crevices and depressions by hand. After this, comes the removal of the capping, which runs from 2 to 5 feet thick, carrying from 5 to 35 per cent. iron. Occasionally in the haste to obtain ore the removal of this rock is neglected and rock and ore are blasted in one promiscuous mass, a process not conducive to economical mining practice, besides entailing costs on other departments of the company.

The mixture goes to the washer, where it piles on the picking belts, and much of it necessarily finds its way into the ore bins.

TABLE 1. PROSPECT HOLES 25 FEET APART

No.	Float	Shale	Sand	Ore	Remarks
1	48	20	4	00	
2	35	49	10	10	Medium
3	3	41	00	20	Medium
4	28	00	00	20	Medium
5	58	00	00	16	Medium
6	00	00	00	32	Good
7	00	00	00	24	Good
8	00	00	00	36	Good
9	00	20	00	16	Good
10	00	30	00	00	
11	00	72	00	00	
12	18	17	00	12	

Freight is paid on it. There is an extra cost for the abnormal amount of coke required, blast is wasted, and slag is increased. Generally speaking, every effort is made to ship clean ore, being mindful of the fact that the ore itself ordinarily contains 55 per cent. of waste. After the stripping is completed it is often found

that the ore in spots is very thin and poor, a demonstration that drill holes 50 feet apart where only a general knowledge is desired may be satisfactory, but are not where one wishes to particularize as a preliminary to actual mining. In this ore much closer drilling should be done, not over 25 feet, and 15 feet apart would be better, for these holes 3 inches in diameter are nearly all eventually used for blasting; thus they serve a double purpose.

Holes 25 feet apart, as shown in Table 1, furnish information that futures the condi-



FIG. 3. FENWICK MINE. LOW MOOR

tions to be met in stripping, in mining, in quality of the ore, and in its preparation.

The quality of the ore is the *bete noire* of the foreman, and if it were richer or poorer it would be easy to decide its finale, but being balanced between the waste pile and the ore bin, it presents an ethical as well as a moral side to the cost sheet.

When foremen are anxious for quantity they take the ethical side of the subject, where the furnacemen always adhere to the moral side as that is ethical with them. It is due to this changeability that the district is known as "the graveyard of furnacemen's reputations." Where much of this change in ore grade occurs, the loading is done by hand. In fact, it is an open question whether the latter method is not always more profitable; for, even in the very best of this ore there are seams of flint and clay, and in addition there is the omnipresent flint foot-wall which disintegrates rapidly on exposure to the atmosphere and almost continually therefore slides and mixes with the ore. The foot-wall, when in contact with water, separates into small checkers and sufficient pickers cannot be gotten at the tables to get it all. Its specific gravity is so near that of the ore that its complete separation by the jigs is an impossibility, and a satisfactory product is only obtained by a serious loss in the tailing.

The only instance where this loss is prevented is at the Jordan washer; here the tailing is recrushed by rolls and rejigged. Much of this material, known locally as "black flint," is not easily distinguished from the ore. In fact, during the examination of one of the mines the superintendent and foreman differed in their judgment concerning a seam traversing a face. The superintendent said "ore"; the foreman, "flint." A sample fractured in daylight decided in favor of the latter. Both of these men with over 30 years' experience were unable to determine the two by sight, and the foreman, although right, was far from positive.



Hoisting at Calumet and Arizona

One of the first electric hoisting outfits in the United States was purchased by J. R. Del Mar for his Del Mar mine, in Owyhee County, Idaho, in the 80's. It proved anything but satisfactory, but since then great strides have been made in engineering, and miners who once refused to work under electric hoisters have now no compunctions against doing so. In September, 1909, The Calumet and Arizona Mining Co., whose Irish Mag mine adjoins the Cop-

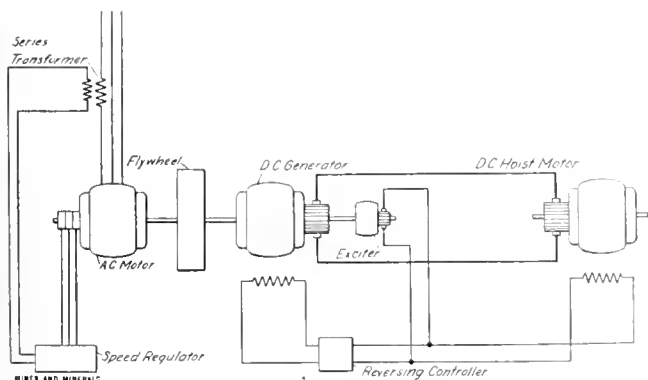

FIG. 1. DIAGRAM OF ELECTRIC HOIST

per Queen, at Bisbee, in the Warren copper district of Cochise County, Ariz., installed what is known as the Westinghouse equalizer system of hoisting. The other shafts of this company had previously been equipped with electric hoisters, consequently it was quite natural that the work performed with the latest improved hoister should be watched. The installation consists of a 220-horsepower, 550-volt, 63-revolutions-per-minute, shunt-wound, commutating pole, direct-current motor, direct connected to the hoisting drums, as shown in Fig. 2.

The motor receives its power from a flywheel motor generator set, which includes a Westinghouse 180-kilowatt, 575-volt, 1,200-revolutions-per-minute, shunt-wound, commutating pole, direct-current generator, shown in Fig. 1; also a 22,700-pound laminated flywheel; a Westinghouse 180-horsepower, 220-volt, three-phase, 60-cycle, six-pole, 1,000-1,200-revolutions-per-minute induction motor; and a 15-kilowatt, 125-volt exciter, with the necessary controlling and regulating devices.

Tests made under severe operating conditions where the hoister is running most of the time during the day, show that the average

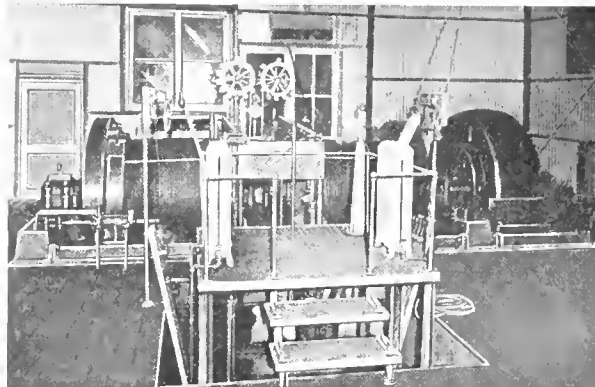

FIG. 2. ELECTRIC HOIST IRISH MAG MINE

input will not exceed 25 per cent. of the maximum load, and that the rate of input is practically constant.

With some small hoists it has been found satisfactory to use alternating-current induction motors directly applied, but where heavy loads are to be raised at high speeds the peak due to the acceleration of the rapidly moving parts is always greatly in excess of the average requirements of the hoist. Further, if the current is obtained from a line also carrying a lighting load, the resulting fluctuations of voltage prove most objectionable. Again, in most cases the hoist is at the end of a long transmission line, and so an excessive amount of copper must be installed to prevent drop in the voltage during maximum demand. Therefore, the line must be equipped for peak instead of average load at a greatly increased expense.

It was to overcome these drawbacks to successful electric hoisting apparatus that the Westinghouse engineers applied their skill. The hoister was to have an unbalanced load of 6,000 pounds that was to be raised from a depth of 1,200 feet at the rate of 1,000 feet per minute. It was decided therefore to electrically connect direct the armature of the generator and the hoisting motor. The field of each machine, however, is excited separately, constant full field being maintained in the motor. The hoist is started by gradually increasing the field of the generator and so delivering a proportional voltage to the hoisting motor. When the load on the alternating-current motor reaches a certain point, resistance is automatically applied to its secondary circuit, reducing the speed of the set, and the energy stored in the flywheel is used to overcome the peak of the hoisting cycle. Thus there is a minimum use of current.

The hoist is stopped by gradually weakening the generator field and thus allowing all excess in the descending cage, the rotating hoisting motor, and the drums to be returned to the flywheel through the generator, which momentarily acts as a motor, receiving energy from the hoisting motor, which for the moment acts as a generator.

The overall efficiency of this hoist is from 50 to 60 per cent. when operating under normal conditions. Because of the ease of control and the general features of the set, it is easy to devise reliable safety devices which do not depend on mechanical brakes.

The first cost of this installation is greater than for a motor hoister with rheostat control, but the reduction of power cost due to the equalization of the load is so great that the initial expenditure becomes a secondary matter, especially when power is purchased on a maximum demand system.

Dry-Placer Mining Methods

Different Kinds of Separating Apparatus Used—Geology of the Dry Placer Deposits

By Wilbur Greeley Burroughs

Of all the various modes of mining, the dry placer is essentially that of the poor man. He is able to construct his own mining apparatus, if he so desires, at an expenditure of but a few dollars. And if he wishes to buy his machine already made, the cost is relatively small, usually between \$50 and \$100. Thus provided with a standard type of dry washer, the miner is on an equal footing with the

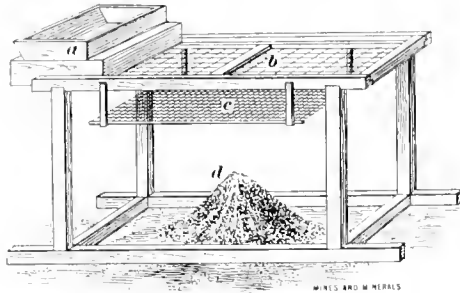

FIG. 1

man of unlimited capital. The reason for this is the climate in which the dry placer occurs, for in a place far removed from water supply, where if any water can be obtained it does not more than meet the needs of the men for drinking purposes, it is impossible to use the customary water placer-mining methods, involving, as in hydraulic and dredge mining, expensive apparatus. In the dry-placer machine, air is used as the separating medium in place of water. Very large dry blowing machines are seldom used, due to their imperfections in separating the gold from great quantities of material, the pockety character of many of the deposits, and the difficulties in the transportation of fuel, hence the small dry blower is predominant.

An illustration of the use of the small dry-blower machine is seen in the founding of Randsburg, Cal., in the early 90's. Three men with a handpower dry washer, two mules, a wagon, and two barrels of water, were prospecting in the Mojave desert of Southern California, about 150 miles southwest of where is now located the town of Goldfield, Nev. Wandering over the desert, they saw in the distance some mountains. They made for them and when they at last arrived, followed a ravine, dry-washing the sand which they got by digging to bed rock several feet below the surface. At length they found gold in unusual quantities. They remained and worked this placer for a while till one day one of them suggested that they go up the ravine and find the vein from which the gold was derived. This was done and a vein 40 feet with a high content of gold was discovered. Securing capital they commenced to mine the vein which they named the Yellow Astor, and the town of Randsburg was founded. It was due to the dry-blowing machine that the camp owes its existence.

Methods Employed in Dry Blowing.—The simplest type of dry blowing is done with two iron pans. The miner fills one pan with dirt. He then shakes the pan bringing the larger pieces of rock and gravel to the top. These he scrapes off with his hand. On the ground is placed the second pan on a blanket. Standing with his side to the wind, the miner pours the dirt from one pan into the other, the wind blowing the finer dust away and the gold and heavier material dropping into the empty pan on the ground. The blanket, the greater part of which is spread to the leeward of the pan, catches any fine particles of gold that are blown away. This process is continued until only heavy material remains. The separation is then further continued by tossing the dirt up and down in the pan, the pan held slanting forward and jerked so as to throw the dirt from the front to the back of the pan. The coarser portions thus separated are removed by hand. The next step is to shake the pan as is done in panning gold where water is used. Separating the waste material which this last operation has freed from the gold, the miner

uses his breath to get rid of any fine dust which remains. He has now in his pan gold and ironstone which he separates by picking out by hand.

The readiness with which this operation is accomplished is due in no slight degree to the climate. Owing to the perfect dryness of the dirt and the heat imparted to the surface of the iron pan under a tropical sun, the material behaves with much of the mobility which it would have if water and not air were the vehicle employed. The rapidity and completeness of the operation depend on the strength and uniformity of the wind. A difference in level of the land where the mining is being carried on, and the near-by land, is often the cause of a constant breeze which assists the dry-placer miner.

There are a number of different kinds of dry-blower machines, but they are all based on the principle of a shaking movement of the material to be separated in the presence of a current of air. In the simplest of these machines the material is passed through a series of screens without any air-current save the wind of the region, the final separation being made by hand as already described.

Fig. 1 shows a simple type of machine 4 feet long by 2 feet wide; *a* is a hopper with sheet-iron bottom perforated by 1-inch holes; *b* is a 12-mesh screen; *c* is an 18-mesh screen, and *d* a final product of the operation which is further separated by hand. With this machine a man can run through about 5 tons of loose dirt in 7 hours.

Fig. 2 shows a somewhat more elaborate type of machine. The trays, 1, 2, 3, 4, and 5, hung from *b*, *c*, *d*, are 22 inches in diameter, comparatively flat, and have screen bottoms; No. 1, has 1-inch holes, No. 2 has $\frac{3}{4}$ -inch holes, No. 3 has a 10-mesh screen, and No. 4 has an 18-mesh screen. No. 5 is flat and retains the final product which is dry-blown by hand. The trays are 5 inches apart, and are held in place by wires, *h*. Through the center of these trays passes an iron rod to eccentric *g*, which receives the required movement through the lever *a e f*, of which *a* is the handle.

The more complicated machine shown in Fig. 4 utilizes an artificial air-current and thus effects a more thorough separation of the gold. In this machine *a* is a hopper; *b*, *e*, *f*, *g*, *h* form a series of screens; *m* is a handle by the turning of which wheel *k* is revolved; and this, by means of a belt, transmits its movement to the pulley which shakes screen *b*, through eccentric-rod *i*, and at the same time, by means of a crank, operates the bellows *d*. The material is put into hopper *a* and the machine set in motion. The large lumps run off over the sizing screen *b*, the finer material falling into chutes *c* and *e* passes to *f* which is a 12-mesh screen supplied with riffles. As it descends through screens *g* and *h*, both 18-mesh, the blast of air from the bellows keeps it in agitation, thus aiding still further the separation between the particles of gold and the dust. The final product is panned by hand.

The machines shown in Figs. 1, 2, and 3 are described by T. A. Rickard, in Transactions American Institute Mining Engineers, Vol. 28. Fig. 3 shows the Woods dry placer machine in operation, which is very similar to the one shown in Fig. 4.

The material composing the placer is often cemented together so firmly that it has to be pulverized to liberate the gold before passing through the dry-blower machine. The difficulty of constructing machines which would pulverize large amounts of hard material and separate the gold from the pulverized rock at a small cost has helped toward keeping dry-placer mining generally in economic insignificance. Up to the last year or two only a few cubic yards

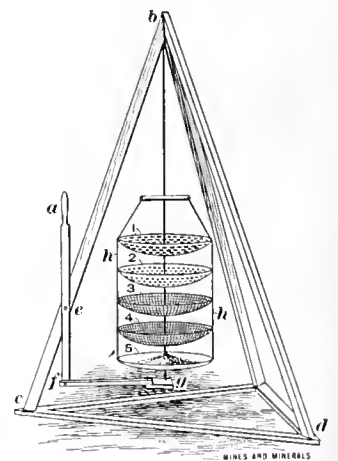

FIG. 2

per day could be handled by any of the machines. There are now on the market a pulverizer and a separator which it is claimed will handle large quantities of material. The pulverizer, it is said, will handle 30 tons of dirt per hour with a gasoline consumption of about 2 gallons. The separator has a capacity it is claimed of 15 tons per hour. These machines are expensive, however, compared to the ordinary dry blower. The pulverizer costs \$1,500 and the separator, \$1,000.

A dry-blowing machine should also be reasonably portable and readily knocked down and set up, for the placers will be scattered. Jigging with magnetic devices is sometimes employed in the separation of the dirt and ironstone from the gold. For the most economical working of certain types of dry placers, lifting and conveying apparatus will be advisable.

Geology of the Dry-Placer Deposit. Placer gravels in the Pacific coast region are derived chiefly from quartz veins of Mesozoic age. The Cretaceous rocks of the Sierras with their veins of free-milling ores disintegrated into good placers with gold of a high degree of purity, but the veins in the Tertiary lavas of the Rockies have not furnished as much placer gold nor of as good quality as that in California. The reason for this is that the Rocky Mountain veins usually contain the metals in such a finely divided condition, or in such combination, that they do not readily accumulate in stream channels

The dry placer may originate in any of the ways that the placer which is worked by means of water is formed—by streams, waves on the shores of lakes or oceans, floating ice, shore ice, and glaciers. The climate being too arid to allow of washing the material, places the deposit in the class of the dry placer. But they are also formed by other agencies than those already cited. These are the deposits formed *in situ* in the weathered and softened portions of the solid veins. The concentration is aided by the winds which blow away the finer and looser material and leave the heavier particles. Rain, when it does come, helps to the same end, removing material both mechanically and in solution. Thus, the residual deposit is very often richer than the vein below. The vein, however, is not always directly below the placer but may be some yards or more distant due to the wind and rain.

In the arid region of West Australia are numerous examples of dry placers *in situ* or only a short distance from the parent vein. The placer deposits are generally patchy in character. They lie at the upper ends of the depressions formed where the ground slopes away from the ridges along which run the veins of gold-bearing quartz. The wind has sorted the residual material, blowing the dust far and wide; the broken pieces of ironstone remain near their seat of origin till they are ground into dust and blown away; the gold, too heavy to be carried far by the wind, will therefore be near the vein of quartz. The finer gold can be found scattered in the sand for half a mile from its point of origin; and gold may also be traced up to the outcrop which yielded it; but the rich and only workable portion of the placer will ordinarily be found at a distance of 30 to 40 feet from the vein.

Of the dry placers formed by aqueous agencies, by far the greater number have been deposited by intermittent streams. These streams are supplied with water from melting snow on the

mountains down which they flow, and by rains that are generally violent while they last. The stream swollen by the "cloud burst," carries an abundant load. In New Mexico boulders up to 10 feet in diameter are found 10 to 20 miles from the mountains from which they came. The water rises quickly and goes down again as rapidly as it rose, depositing the material it was carrying. These floods sometimes cut gullies in the surface of the land. After the water has subsided and time goes on, these gullies, by gradual erosion and deposition, will become smoothed over and level with the surrounding

plain, but in their hidden channels may be deposited gold, brought down when the depression was filled with a raging torrent. The gold pay streak occurs in places in rather large sheets as though deposited on the going down of a great flood. In other places the gold is in a narrow and crooked pay streak evidently left in the bottom of the gully proper.

In an arid region there is no predominant bed rock. The gold cannot settle upon the true bed rock except when that happens to form the bottom of a wash or channel, because the flow of water lasts but a few hours and there is no time to soften the underlying earth except for a few inches. The pay streaks will be found at various levels above the true bed rock. In some regions an important false bed rock above which the gold accumulates is at or near the grass roots. The reason is that the soil on becoming wet changes to mud for a few inches down and the gold sinks through this mud until it comes to the hard ground into which it cannot sink; the grass roots though making the ground more permeable, do not penetrate the hard earth beneath where the rain water ceases to soften the soil, so that the pay streak and the grass roots are located near one another. This is true not only in the case of gold deposited by intermittent streams, but also in placers formed near the gold bearing vein by wind and rain. Further erosion on the surface by wind and rain takes place. The gold, protected by the soil above, becomes more and more concentrated, as hundreds of feet of material containing small quantities of gold are removed, leaving behind the heavy particles of gold. The gold thus left sinks a few inches into the ground until it comes to an impervious formation where it remains until the false bed rock is softened, due to the lowering of the surface above, when it once more sinks to the new bed-rock level. An extremely rich placer is thus formed.

Placer gold is found in the wash from volcanic mountains. At some of the dry-placer regions of New Mexico, the lower slopes of the mountains are covered with talus. The gold is at one or more levels, sometimes at or near true bed rock, at others many feet above it. It occurs in pay streaks that are usually less than one or two feet thick. They are narrow, and seldom more than a few feet or rods in length. The material, ranging from dust to boulders, is firmly cemented, the cement being a fine earthy matter often bound by lime and iron oxides and hydrates. Other kinds of placer cement are the alkaline earths, borates, sodium chloride, sodium nitrate, and sodium sulphate. The pay streaks are often tunneled and mined like coal. After the tunneling and shafting have been completed, the material containing the gold is mined and hoisted to the surface where it is dried, pulverized, screened, and dry washed.

In the Altar district of Sonora, Mexico, where a considerable

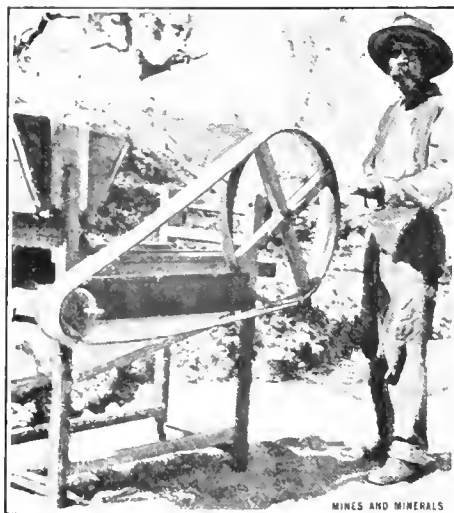

FIG. 3

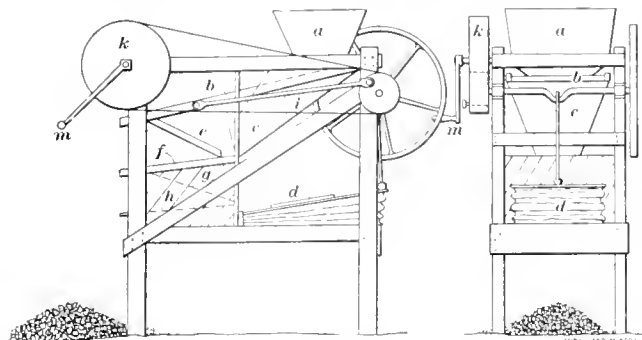

FIG. 4.

amount of dry washing is carried on, there is a saying that the Indians leave some gold in the placer they are working as seed so that more gold will grow. The basis for this belief is that unless the cemented gravel is separated grain from grain, all the enclosed gold will not be released. But the tailing from the dry-blowing machine, after lying in the sun and rain for a length of time, will have become disintegrated so that the particles held by the cement are set free, and on dry washing once more, this gold, which it was impossible to recover the first time, will be secured.

Dry placer mining in the United States is carried on chiefly in the arid regions of Southern California, Nevada, New Mexico, and Arizona. In the last mentioned state a rich gold placer area lies west of Tucson and extends north and south some distance on both sides of the Mexican boundary line. In 1907, Yavapai, Yuma, and Pima counties produced the largest quantities of placer gold in Arizona, most of this gold being obtained by dry washing and some sluicing. Numerous dry placers are reported.



El Paso Shaft, Cripple Creek, Colo.

The El Paso mine, midway between Victor and Cripple Creek, is of interest as being the property through which, by means of a bore hole, the mines of the district are draining into the Roosevelt tunnel. The following notes, furnished by W. G. Zulch, mining engineer, Cripple Creek, Colo., show some other interesting features:

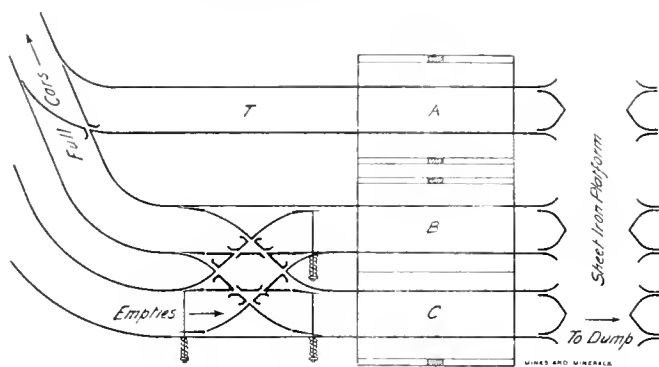

FIG. 1

The use of rails and switches in place of the customary transfer plate is to be commended as being much easier in operation. The diamond spring switch used on the ore-house level is shown in Fig. 1, and the drawing is practically self-explanatory.

As the full cars always take the one track to the ore bins, the spring switches are set accordingly. The empties, always returning on the same track, require that a "kick" switch be used for their proper distribution. The track *T* is used as a storage for empties, two sizes of cars being used, the smaller going to the lower levels and the larger being supplied to lessees on the upper levels.

Fig. 2 shows the compartment arrangement at the ground level. The smaller compartment is now occupied by a single-decked cage as a counterbalance for the cage in the larger compartment. This single-decked cage is being replaced by a standard double-decked cage. The double-tracked cage on which two cars are placed side by side is an unusual and commendable feature in ore mining, although the practice is old in coal mining. The time saved in loading and unloading a cage of this type over one of the ordinary double-deck type is apparent.

The main cage is of an unusual type and is shown in plan and elevation in Fig. 3. The arrangement of the guides is peculiar and well illustrated by the small space available. It will be noted that this compartment is also provided with a holder.

The main hoisting engine is of the Webster, Camp & Lane type and is used for flat rope. The hub of the reel is 2 feet 6 inches in diameter and the reel when full of rope is 12 feet in diameter. The drum diameter is 2 in. x 5 in. and consists of 14 ropes of four strands

each. The engine, whose cylinders are 16 in. x 48 in., hoists from a depth of 1,020 feet cars that weigh, when light, from 850 to 950 pounds, and when loaded, from 2,000 to 2,500 pounds.

The man engine is of most peculiar design, and is intended for use in cramped spaces. The dimensions are, cylinders 9 in.

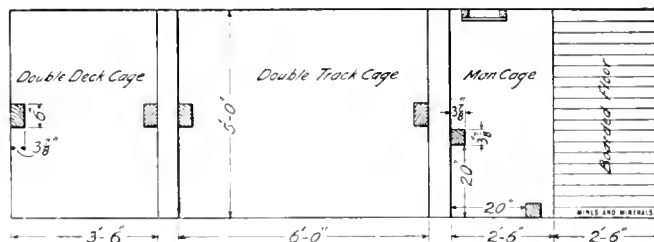

FIG. 2. PLAN OF EL PASO SHAFT

x 22 in., drum 24 inches, cable 3/4 inch, depth of hoisting 1,000 feet. This is a remarkably small size engine and drum for hoisting from such a depth.



Cold Production in 1910

According to figures compiled by Charles G. Yale for the United States Geological Survey, the mine production for California in 1910 was gold, \$19,715,440; silver, \$993,646; copper, \$6,184,996; and lead, \$126,323. This is a decrease in gold, silver, and copper, but an increase in lead.

There were 1,079 mines producing gold, silver, copper, or lead in California in 1910, of which 564 were gold placer mines. Of the deep mines 485 were gold mines, nine were silver mines, 10 were silver-lead mines, and 11 were copper mines. Of the placer producers 168 were hydraulic mines, 72 were dredges operated by 41 companies, 139 were drift mines in ancient river gravels, and 185 were sluicing mines. Measured by the number of producers as well as by tonnage and metal output, deep mining decreased somewhat in California in 1910. Among the placers sluicing decreased also, but dredge and drift mining increased.

According to figures compiled by Charles W. Henderson for the United States Geological Survey, the production of gold, silver, and copper decreased in Colorado in 1910, while that of lead and zinc increased. The total value of all metals was \$33,673,870, of which amount gold was \$20,507,058.

According to statistics supplied the United States Geological Survey by V. C. Heikes, Nevada had an increased production of gold, silver, and copper, but a decreased output in lead and zinc in 1910. The total value of all metals amounted to \$34,152,148, of which \$18,878,864 was gold; \$6,739,130, silver; \$8,173,643, copper; \$214,329, lead; and \$146,182, zinc. The Goldfield district, Esmeralda County, produced \$11,137,150 of the gold.

V. C. Heikes also furnished the figures for Utah, and states that the output of copper and zinc increased, while that of gold, silver, and lead decreased. The total value of all metals amounted to \$32,199,185, of which \$4,032,085 was gold.

Mr. Heikes gives \$42,731,519 as the total value of the metal production of Arizona in 1910, of which amount \$3,149,306 was gold; \$1,385,925, silver; \$37,781,376, copper; \$118,668, lead; and \$296,184, zinc. While there were 373 mines in operation in 1910, compared with 208 in 1909, there was an increased output in gold but a decreased output in silver, copper, lead, and zinc.

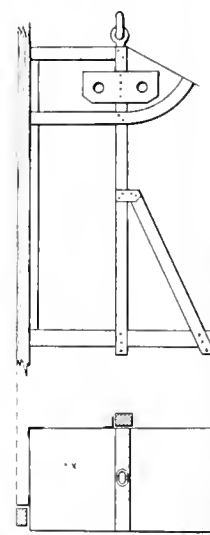

FIG. 3

The Specific Gravity Flask

Determinations of Specific Gravities of Pulps by the Specific Gravity Flask

By H. Stadler

The following is extracted from H. Stadler's paper, "Practical Applications of the Specific Gravity or Moisture Flask," which appeared in the November, 1911, issue of the Journal of the Chemical, Metallurgical, and Mining Society, of South Africa.

These notes show the practical possibilities of the specific gravity flask, which should prove to be one of the most useful and indispensable instruments for efficient and reliable control of the conditions of mill pulp.

It has been found that flasks having a large mouth ground true, the ground edge to be used as the mark of capacity, are more convenient for taking fair samples than the usual glasses with a mark below the mouth. In consequence of sand adhering to the glass above the mark, the latter are more difficult to fill accurately.

I. Determination of Density (Specific Gravity) of Solids.—If the specific gravity of the solid ore under treatment be not taken at an accepted average value it may be determined by any well-known method; for instance:

If the material is dry, a known weight (in grams) of the material under examination is placed in the flask, and water added up to the mark (in the suggested flask up to the top), the total weight of the contents is then taken. The density is obtained by the use of formula (1), Table I. Wet material, such as mill pulp, is preferably dried and weighed after the determination of the specific gravity of the pulp.

II. Determination of Specific Gravity of Pulps. Almost all factors determining the nature of pulps, from the mill man's point of view, are governed by the specific gravity of the pulp. If the metric system of weights be used, the specific gravity is at once obtained by dividing the net weight of the pulp by the volume occupied, or, when a 1,000-cubic-centimeter flask is used, by cutting off the last three decimals of the net weight of the pulp (in grams).

The specific gravity of slime pulp, in which all solids are freely suspended, may be measured by a hydrometer.

III. Determination of Percentage (by Weight) of Dry Solid and Water.—Although the specific gravity is representative of the constituency of pulps, the percentage of dry solid or moisture conveys a more definite impression to the average mind.

The usual method of determining the percentages of solids and moisture, by drying and weighing, is troublesome, unreliable, and inaccurate. Hence, methods based on specific gravity, formula (3), Table I, are quicker and more convenient.

Any alteration in the composition and in the rate of flow of pulps is shown by a marked change in the percentage of moisture and therefore gives a reliable, sensitive, and effective control in the uniform distribution of the pulp and the regular working of the classifiers. For instance, at a mine where a set of eight similar classifiers was fed with the same battery pulp, the moisture in the underflow of the different classifiers varied, at the same moment, from 35 to 75 per cent., thus showing that the distribution of the pulp over the classifiers was very irregular.

It is to be hoped that with such a convenient means at hand, mill men will pay more attention to the control of individual units, as the total average always gives more or less practicable figures, but which are no help in detecting faulty work.

IV. Tonnage Measurements of Total Pulps (Tp) and of Dry Solid in Pulps (Ts).—Tonnage measurements of flowing quantities are generally made by running pulp for a measured time into a vessel of sufficient capacity to give fairly accurate results. Scales for weighing the large quantities collected are not available, and the drawing off of the water, drying, and weighing of the solid portion in such quantities still less practicable.

All these inconveniences are avoided by reckoning the tonnage

from the volume occupied by the total pulp (in cubic feet) and its specific gravity, by formula (4) for the total pulp, and by formula (5), in Table I, for the dry solid portion only.

The simplest manner to carry out these measurements is to run the pulp into a box of known capacity, large enough to take at least 1 minute's flow of the stream. The exact time required for filling is taken by a stop watch, the point of overflow being easily and exactly determinable. The specific gravity is determined from separate representative samples taken simultaneously, and the calculated weight of pulp or dry slime passing during the time t (in seconds) is then used to give the hourly or daily quantities.

If, in all measurements, boxes of equal capacity are used, for instance, 16 cubic feet (the volume of half a ton of water), all the constant factors may be condensed into one. For a box of the above capacity the formulas for Rand ore are:

$$\begin{aligned} \text{Tons of total pulp in 24 hours: } Tp &= \frac{43,200 p}{t} \\ \text{Tons of dry solid only } Ts &= \frac{(p-1) 68609}{t} \end{aligned}$$

Since the capacities of launders, vats, pumps, etc., as well as the rates of overflow of classifiers are determined by the volume of the pulp, the "fluid ton" of 32 cubic feet (equal to the volume of 2,000 pounds water, on the assumption that 1 cubic foot of water weighs 62.5 pounds) is frequently used as a unit in milling work. The tonnage of pulps of known specific gravities is readily converted into fluid tons by formula (7) for the total pulp and by formula (9), Table I, for the dry solid portion.

The same method is also applicable to tonnage measurements of vats, etc., provided the consistency of the pulp is not changed by drawing off water or slime (as is the case with sand-collecting and slime-settling vat), or by adding cyanide solution (as happens with slime-treatment vats). For large tonnage measurements the practical utility of this method is therefore confined to agitation or circulating vats, and in all other cases, for lack of better methods, resort is made to the method commonly practiced, inaccurate as it is, of estimating the dry solid by the established dry weight of the settlement volume. This varies considerably with the nature and the fineness of the ore, and should therefore be checked frequently, and corrected if necessary by actual test. For such tests the method described is suitable, as no draining nor drying is necessary.

At the Knight Central Gold Mining Co. the daily tonnage measurements of the mill pulp for several years past have been regularly taken by the gravity method, which, after careful investigation, was found to give most reliable results. In addition there is the advantage that it can be carried out without waiting for settlement of the slime. After filling the first transfer tank with solution and after circulation (the whole operation taking about 4 hours) two samples are taken, one at the delivery pipe, representing the pulp at the bottom of the tank, and one from the upper part, to get a representative average for the whole content.

V. Relations of Flowing Quantities in Classifiers.—The relation of flowing quantities in classifiers may be calculated from the percentage of any of their components measured at the inflow, overflow, and underflow. No component can so quickly and reliably be measured as the percentage of dry solid taken with the specific gravity flask. From the percentages of dry solid so obtained, the tonnage of the total pulp underflow (as a percentage of the total pulp inflow) is calculated by formula (10) and the tonnage of dry solid underflow (as a percentage of dry solid inflow), by formula (11), Table I. In neither case is it first necessary to calculate the percentage of solid, since the flowing quantities of the underflow can directly be determined from the values of the specific gravity, by formula (12) to get the percentage of the total pulp, and by (13), Table I, to that get of the dry solid portion only.

Accuracy.—The accuracy obtainable by the specific gravity method is only limited in practice by the accuracy with which the means at disposal determine the correct values of (A), the volumetric weight of the pulp w ; (B), the density of the solid d ; and (C), the specific gravity of the liquid ρ .

A. Accuracy of Volumetric Weight of Pulp.—When using a 1,000-cubic-centimeter flask an error in content or in weighing of even 10 cubic centimeters or grams, respectively, affects the specific gravity p of the pulp in the third decimal only. For a 1 : 1 pulp the error is .007 per cent., which increases with the dilution of the pulp.

A variation in p of .01 in a 1 : 1 pulp (Rand ore) gives an absolute error of .74 per cent. in the calculation of the dry solid or moisture percentages, corresponding to 1.48 per cent. of the true value. With the dilution of the pulp the error increases progressively. The accuracy of the tonnage measurement of the total pulp varies as that of p , whilst the tonnage of the dry portion shows an error of 2.17 per cent., which increases progressively with the dilution of the pulp. If such rough work is allowed in milling prac-

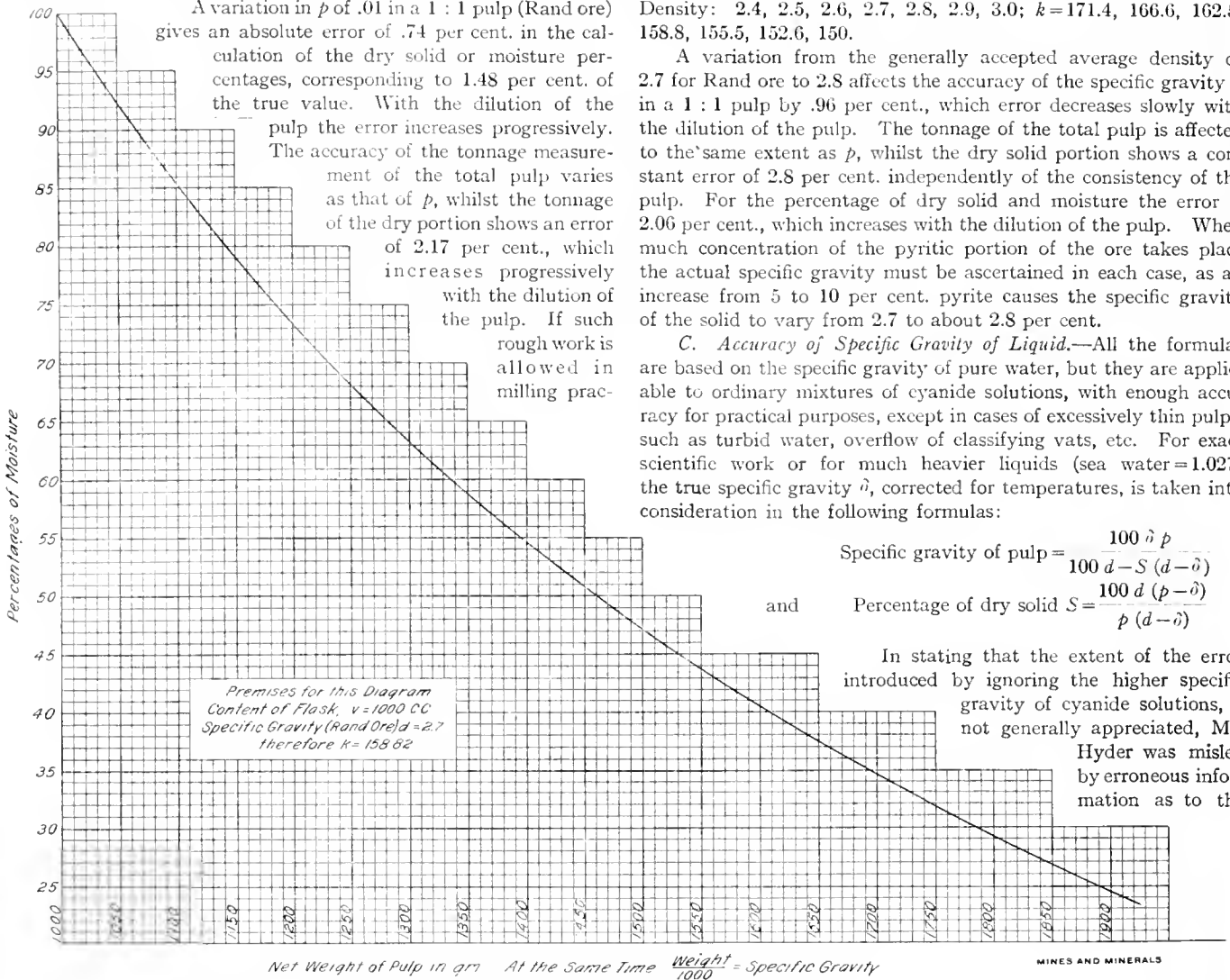

tice the curve shown in Fig. 1 gives the percentage of moisture or solid within 1/2 to 1 per cent.

B. Accuracy of Density of Solid.—It seems that the average density of Rand ore is, at least, for individual mines, fairly steady. The constant k in the formula varies with the density as follows: Density: 2.4, 2.5, 2.6, 2.7, 2.8, 2.9, 3.0; $k=171.4, 166.6, 162.5, 158.8, 155.5, 152.6, 150$.

A variation from the generally accepted average density of 2.7 for Rand ore to 2.8 affects the accuracy of the specific gravity p in a 1 : 1 pulp by .96 per cent., which error decreases slowly with the dilution of the pulp. The tonnage of the total pulp is affected to the same extent as p , whilst the dry solid portion shows a constant error of 2.8 per cent. independently of the consistency of the pulp. For the percentage of dry solid and moisture the error is 2.06 per cent., which increases with the dilution of the pulp. When much concentration of the pyritic portion of the ore takes place the actual specific gravity must be ascertained in each case, as an increase from 5 to 10 per cent. pyrite causes the specific gravity of the solid to vary from 2.7 to about 2.8 per cent.

C. Accuracy of Specific Gravity of Liquid.—All the formulas are based on the specific gravity of pure water, but they are applicable to ordinary mixtures of cyanide solutions, with enough accuracy for practical purposes, except in cases of excessively thin pulps, such as turbid water, overflow of classifying vats, etc. For exact scientific work or for much heavier liquids (sea water=1.027) the true specific gravity δ , corrected for temperatures, is taken into consideration in the following formulas:

$$\text{Specific gravity of pulp} = \frac{100 \delta p}{100 d - S (d - \delta)}$$

$$\text{and Percentage of dry solid } S = \frac{100 d (p - \delta)}{p (d - \delta)}$$

In stating that the extent of the error introduced by ignoring the higher specific gravity of cyanide solutions, is not generally appreciated, Mr.

Hyder was misled by erroneous information as to the

Table 1. Practical Applications of Specific Gravity, or Moisture, Flask

n = Net Weight of (v) c. c. Pulp, in gm.
 v = Content of Flask, in c. c.
 p = Specific Gravity of Pulp (Mixture of Water and Solid).
 d = Density, or Specific Gravity of Solid.
 $T p$ = Tons Pulp (Water and Solid).
 $T s$ = Tons Dry Solid in Pulp.
 W = Per Cent. (by weight) of Moisture in Pulp.
 S = Per Cent. (by weight) of Dry Solid in Pulp.
 V = Volume of Pulp in Cubic Feet.
 k = A Constant for Any Particular Value of d ;
 $= \frac{100 d}{d-1}$. For $d=2.7$ (Rand Ore) $k=158.82$.
 $F l$ = Fluid Tons (1 fluid ton = 32 cubic feet pulp = volume occupied by 2,000 lb. water, if 1 cu. ft. of water = 62.5 lb.).

I. Determination of Density d of Material σ in gm.
 (1) $d = \frac{\sigma}{v + a + n}$

II. Relation between Specific Gravity p and Net Weight n of Pulp.
 (2) $p = \frac{n}{v}$, $n = v p$

III. Relation between per cent. of Dry Solids S and Moisture W , and Specific Gravity of Pulp p . $W + S = 100$ per cent.

(3) $S = \frac{(p-1)k}{p}$, $p = \frac{k}{k-S}$

IV. Tonnage Measurements of Pulps ($T p$), and Dry Solids in Pulp ($T s$).
 (4) $T p = V \cdot .03125 p$, $T s = V (p-1) \frac{k}{3200}$;
 or for $k=158.8$ (Rand Ore)
 (5) $T s = V (p-1) \cdot 04963$
 Tonnages and Fluid Tons,
 (6) $T p = F l p$
 (7) $F l = \frac{T p}{p}$, $T s = F l (p-1) \frac{k}{100}$;
 or for $\frac{k}{100} = 1.588$ (Rand Ore)
 (8) $T s = F l (p-1) 1.588$
 (9) $F l = \frac{T s}{(p-1) 1.588}$

V. Relation of Flowing Quantities in Classifiers.
 Inflow i
 $W i$ = per cent. water
 $S i$ = per cent. dry solid
 $I p$ = Tons pulp inflow
 $I s$ = Tons dry solid inflow

Overflow o
 $W o$ = per cent. water
 $S o$ = per cent. solid
 $O p$ = Tons pulp overflow in per cent. of inflow
 $O s$ = Tons dry solid in per cent. of inflow

Underflow u
 $W u$ = per cent. water
 $S u$ = per cent. dry solid
 $U p$ = Tons pulp underflow in per cent. of inflow
 $U s$ = Tons dry solid in per cent. of inflow

Quantities of Underflow in per cent. of inflow
 (10) $U p = 100 \left(\frac{S i - S o}{S u - S o} \right)$
 (11) $U s = \frac{100 S u (S i - S o)}{S i (S u - S o)}$
 (12) $U p = \frac{p u}{p i} \times \frac{100 (p i - p o)}{p u - p o}$
 (13) $U s = \frac{p u - 1}{p i - 1} \times \frac{100 (p i - p o)}{p u - p o}$

average density of ordinary cyanide solutions. This strength does not generally exceed .18 per cent. for sand, .025 per cent. for slime, and .3 per cent. for black sand. I am indebted to Mr. M. T. Murray, lecturer of the South Africa School of Mines, for the exact determinations of the specific gravity of an ordinary cyanide solution, assaying .126 KCN and .01 alkalinity. He obtained a value of 1.0021, and from the data given above it will be seen that the small variation from the specific gravity of pure water is negligible.

采 采

The Hollinger Mine Report

The much looked for report on the Hollinger property, at Porcupine, made its appearance in the latter part of January. The following excerpts of the report were taken from the Cobalt *Nugget*, and it will be seen that it is based largely on estimates. Manager Robbins estimates that there are 462,000 tons of ore in sight, whose gross value is \$10,230,000. Comprehensive tests made upon the ore show that by cyaniding practically complete extraction of gold is possible. The report contains results of

ESTIMATED TONNAGE AND VALUES OF HOLLINGER ORE

Vein	Depth Working	Depth Vein Allowed	Estimated Tonnage	Gross Gold Contents
1	200 feet	300 feet	210,000	\$7,568,000
2	200 feet	200 feet	110,000	1,200,000
3	100 feet	100 feet	20,000	150,000
4	100 feet	200 feet	35,000	450,000
8	100 feet	200 feet	10,000	140,000
Miscellaneous veins, surface			77,000	730,000
Totals			462,000	\$10,230,000

sampling on various veins both upon the surface and underground, the estimates of tonnage and gold are based upon conservative allowances for the persistence of values beyond the present workings. Approximately 3,000 samples were taken, involving the chipping of 8,400 feet of sample trenches. A minimum stoping width of 3 feet has been allowed and a minimum of \$4 a ton has been included as payable.

No. 1 vein has a surface exposure of 950 feet, average width 9½ feet, average assay \$32.96 a ton in gold. One-hundred-foot level, 1,000 feet of drifting in ore, average width 8 feet, average gold \$31.54 a ton; 200-foot level, 350 feet of drifting, average width 9½ feet, average in gold \$49.30 a ton.

No. 2 vein is exposed upon the surface for 300 feet, average width 7 feet, average in gold \$7 a ton. Cross-cut at three points upon 100-foot level proving additional length of 450 feet, cross-cut at one point upon 200-foot level 25 additional feet of drifting upon 100-foot level. Cross-cuts show the following values at points cut: \$7.20 over width of 13 feet; \$16 over width of 8 feet; the drift upon the 100-foot level averages approximately \$20 over the width of the drift for the distance of 25 feet driven.

No. 3 vein is exposed 350 feet upon the surface, shows the average in gold to be \$9.30 a ton over width of 5½ feet. Thirty-five feet of drifting upon 100-foot level shows \$4.50 in gold a ton, over an average of 5½ feet.

No. 4 vein is exposed 375 feet on the surface and shows an average gold content of \$11.60 a ton over an average of 8 feet. Cross-cut at 100-foot level shows width of 22 feet and average in gold of \$16 a ton over the full width. Fifty feet of drifting at 100-foot level shows \$32.40 in gold a ton across the width of the drift.

No. 8 vein shows an average width of 7 feet, carrying \$13 in gold over an average length of 86 feet upon surface. Cross-cut upon 100-foot level shows width of 25 feet and gold to the value of \$7 a ton. Besides the above-mentioned veins there are 31 veins upon which no development work has been done. These have been exposed at intervals upon the surface and thoroughly sampled.

In the aggregate the ore bodies so far discovered will yield for each 100 feet of depth, approximately 225,000 tons, containing gross gold amounting to \$4,000,000, from which a net profit of \$2,500,000 may be expected for each 100 feet of depth.

采 采

Stope Model

By W. G. Zulch, E. M.*

This model was made to be used as an exhibit in a lawsuit between the lessees and one of the largest companies in the Cripple Creek district. The lease was not a block lease, as is the usual method of giving leases in the district, but was given on a certain vein. This vein intersected with two others, and the lessees followed one of the other two, which caused the trouble. The model was to show on a large scale just how the veins were situated, and it did much to make the situation clear.

The model is made on a scale of 5 feet to the inch. The first step was to saw the drifts out of boards of the required thickness, a band saw being used for the purpose, and then secure these drifts in their relative positions. The lowest level was first secured to the baseboard of the model. Next the main braces were put in. These are ¼-inch iron rods, threaded at the ends. The lengths, and also the amounts which these rods must be bent, can easily be figured, since the horizontal distance between the points which are to be the ends of the braces may be scaled from the mine map, and the distances between levels are known. The relative position of the levels is obtained by suspending a small plumb bob from one level to the one beneath. The outlines of the stopes are shown by small wires. These are in the form of horizontal contours, showing intervals of 5 feet, held together by vertical cross-sections, and soldered at the intersections. These cross-sections are easily determined in the mine by suspending the tape from a point on the roof of the stope, and taking off-sets on the way down. This is done at regular intervals. The model is easily made, and shows the drifts and stopes on large scale, very clearly and accurately.

采 采

It is remarkable how few take advantage of a fairly well known property of lead, namely, that for a considerable range of temperature below the point of solidification lead is brittle and can be broken up by bars. If the lead is broken up as it solidifies it can be readily hooked out of the way and the running mass cleaned up in a short time. If it is allowed to get cold it takes hours to cut it up with hammer and chisel.

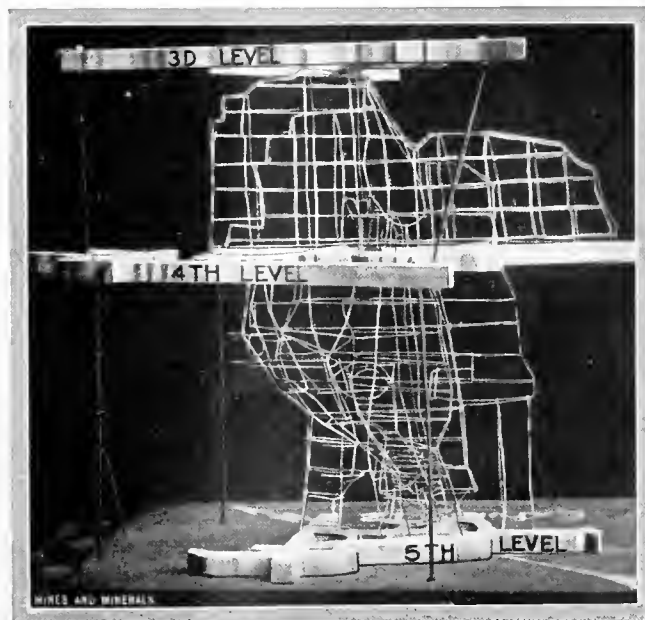

STOPE MODEL

* Cripple Creek, Colo.

Milling the Tam O'Shanter Ore

Transporting Ore With an Aerial Tramway—Water Power for Electric Drive—Milling Methods

By James M. McClave

The Montezuma Tam O'Shanter group of claims at Ashcroft, Colo., was operated during the early days of the Leadville excitement by the late Senator Tabor. The surface ores were rich in lead and silver, but with depth became complex, the lead being in a large measure replaced by zinc, and were unsuited to the smelting operations of the time. At that date, and in fact until comparatively recently, little was known of zinc ores by the average Colorado miner, and in sorting for shipment zinc sulphide was often mistaken for lead. A large shipment made through this error was sent to the old Philadelphia smelter at Pueblo, Colo., and upon being found to contain some 20 per cent. of zinc, was dumped into the Arkansas River. This discouraged the owners and the property was permitted to lie dormant over 25 years until the increased demand for lead ores and the lesser penalization for zinc in lead ores permitted the reopening of the mines and the erection of a modern mill designed to make a lead concentrate suitable for shipment and a zinc-lead middling which is being stored pending the development of a process for its treatment.

The cross-cut tunnel from which the present ore supply is derived is at an elevation of 12,800 feet above sea level and is 2,300 feet above the mill. The mine and mill are connected by a Bleichert gravity aerial tramway 6,100 feet in length built by the Trenton Iron Co., of Trenton, N. J. The cables are supported on 23 wooden frame towers and carry 36 special buckets, Fig. 3, for both passengers and ore. Fig. 2 shows the necessity for an arrangement that will carry both ore and passengers. The carrier cables are $1\frac{1}{2}$ inches, the return cable 1 inch, and the traction cables $\frac{3}{4}$ inch in diameter, all being of the lock-coil type. While the capacity of the tram is 10 tons per hour, 75 tons are usually carried in an 8-hour shift. Three men are required to operate the tram, one at the mine to attend to the brake, a second at the same point

to load the buckets, and a third at the lower terminal to dump the buckets and return them to the cable. When working full the cost of operation for 75 tons in 8 hours is, for three men at \$3.50 each, \$10.50, and for oil and supplies, 25 cents, a total of \$10.75, equivalent to 14.75 cents a ton.

Hydraulic power is obtained from both Castle and Montezuma creeks. A 12-foot dam on the first-named stream impounds 150,000 cubic feet of water, which is conveyed a distance of 2,100 feet to the mill through 400 feet of 18-inch steel-riveted pipe, 500 feet of the same kind of pipe, but 16 inches in diameter, and 1,200 feet of 12-inch wrought-iron pipe. At the mill, under 400 feet head and through a $1\frac{1}{2}$ -inch nozzle, the water operates an impulse water wheel 4 feet in diameter provided with a water regulator. The water wheel drives a General Electric direct-current generator developing 75 kilowatts at 250 volts. This, in turn, operates five motors as follows: One of 30 horsepower driving the tube mill, jigs, five tables, sand pump and classifier; one of 25 horsepower driving the Blake crusher; two of

5 horsepower each driving, respectively, a cross-cut saw and the elevator at the tram terminal; and one of 3 horsepower operating the machinery in the assay office.

Montezuma Creek is closed by an 8-foot dam serving as a head gate only, as no water is impounded here. Fourteen hundred feet of pipe line, consisting of 300 feet of 8-inch galvanized riveted pipe and 1,100 feet of 6-inch steel riveted pipe, conveys the water to the mill where, over the ore bin in the upper part of the building, it operates a double waterwheel 2 feet in diameter. The water discharged from this wheel is taken to a storage tank whence it is used on the jigs and tables. This wheel, which develops 50 horsepower, is belted to a main line shaft and drives two sets of rolls, three trommels, and the main elevator and conveyer belt.

The mill building, shown in Fig. 3, is placed below the tram terminal on a 45-degree slope of the mountain, and is 44 feet high with four floors 40 ft. \times 42 ft. in dimensions. On the first floor are the boiler room and lead-concentrate bins; on the second floor, the tube mill, sand pump, and tables; on the third floor, the rolls, jigs, classifier, and motor; and on the fourth floor, the crusher, conveyer, screen, waterwheel, and electric motor.

As stated, the mill is designed to treat a lead-zinc ore, making a finished lead concentrate suitable for smelting, and a zinc middling which is



FIG. 1. TAM O'SHANTER MILL AND TRAMWAY TERMINAL



FIG. 2. TAM O'SHANTER TRAMWAY

stored on the ground pending the development of a method of separating the zinc and iron. Following the course of the ore, the mill equipment in detail is as follows: Fourth floor, one 9"×15" Blake crusher driven by a 25-horsepower electric motor, one 75-foot 14-inch canvas conveyor fitted with standard carriers and return idlers, a 23-inch iron frame double waterwheel with 6-inch gate valve and an 8-foot shaft with triple bearings, three 3'×6' standard trommels with iron housings (No. 1 covered with a 5-millimeter punched steel screen, No. 2 with a 10-mesh wire screen, and No. 3 with a 20-mesh wire screen), a 26-foot main line shaft fitted with pulleys for driving rolls, elevator, and screen line, and provided with a clutch for throwing out the rolls, and an ore bin of 100 tons capacity.

On the third floor is a 30-horsepower electric motor equipped with starting box, automatic circuit breakers, speed controller, and volt and ammeters, which drives the main line shaft. There are also on this floor one Challenge ore feeder, two sets of 14"×27" rolls, one main elevator with 32-foot centers, 12-inch rubber elevator belt with pressed steel buckets with 36-inch head and 21-inch boot pulleys, working in a cast-iron boot, one double four-compartment Hartz jig with cast-iron body and frame, the compartments being 24 in. × 36 in. in size, one 1 1/2"×20' line shaft with pulleys and belts for driving the jig, one 2 1/2"×28' main line shaft with the necessary pulleys and belts for driving the tube mill and the table and jig line shafts, and one six-compartment classifier.



FIG. 3. BUCKET FOR PASSENGERS AND ORE

bin, the ore is fed by a Challenge automatic feeder to the No. 1 14"×27" coarse-crushing rolls, and thence to the elevator to No. 1 trommel with 5-millimeter openings. From the No. 1 trommel the oversize goes to a set of fine-crushing rolls and back to the main elevator, thus making a very close circuit on the roll crushing. The undersize from the No. 1 trommel goes to No. 2 trommel, from which the oversize goes to the coarse side of the double four-compartment Hartz jig, and the undersize to No. 3 trommel. The oversize from this No. 3 trommel goes to the fine side of the Hartz jig, and the undersize to a six-compartment classifier.

The jig makes three products: a finished lead concentrate from the hutches of the first compartment having the following composition: Silver, 24 ounces; lead, 45 per cent.; iron, 12 per cent.; copper, 1.25 per cent.; silica, 4 per cent.

A lead-zinc middling is made in the second, third, and fourth compartments, which is discharged through the main launder to the storage pile, and has the following composition: Silver, 15 ounces; lead, 5 per cent.; zinc, 20 per cent.; iron, 15 per cent.; silica, 15 per cent. The tailing goes to the creek.

The regrinding of zinc middling in a tube mill was a novelty 3 years ago, but is now recognized as standard practice. When properly equipped, a tube mill will handle this product better than a Huntington or Chilean mill. The tube mill reduces the jig middling to 20 mesh, discharging it into an elevator, and thence to an 8-foot Callow tank. The overflow from the Callow tank goes to

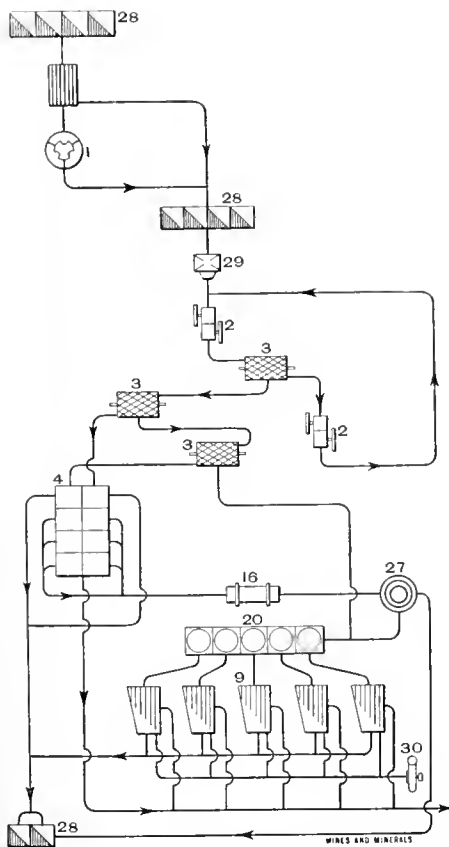

FIG. 4. FLOW SHEET

1, Crusher; 2, Rolls; 3, Trommels; 4, Jigs; 9, Concentrating Tables; 16, Frue Vanners; 20, Richards Jigs or Classifiers; 27, Callow Tanks; 28, Ore Bin; 29, Ore Feeder; 30, Centrifugal Pumps

On the second floor are one 4'×10' tube mill with gear drive and clutch pulley; one 2 1/2-inch centrifugal sand pump, five concentrating tables, and one 1 1/2"×36' line shaft with pulleys and belts to drive the tables and sand pump.

On the first floor are one 10-horsepower portable locomotive boiler for heating the buildings, and two 100-ton capacity each lead concentrate bins fitted with cocoa matting filter bottoms.

The ore is a complex lead-zinc, iron sulphide carrying some silver and copper. The gangue consists of a hard quartz and a yet undetermined metamorphic rock,

the ore as it comes to the mill containing considerable country rock due to fracturing of the hanging wall. Daily mill samples show the following average content for the crude ore: Silver, 8 ounces; lead, 7 per cent.; zinc, 7.5 per cent.; iron, 8 per cent.; copper, .5 per cent.; silica, 40 per cent. This is concentrated to an 8 to 1 lead concentrate and a 10 to 1 zinc middling. The flow sheet of the mill is shown in Fig. 4.

The crude ore from the mine is discharged by the tram line into a storage bin of 200 tons capacity. It is then passed over a grizzly with 2-inch openings. The undersize goes to the conveyer belt and thence to the mill storage bin, and the oversize to a small platform in front of the crusher, through the crusher to the conveyer, and thence also to the mill storage bin. The 9"×15" crusher has a capacity of 15 tons an hour, and operating one shift supplies enough material to keep the mill running three shifts. From the crude ore mill storage

TABLE 1

Products	Tons 24 Hours	Per Cent.	Assays					
			Ag	Pb	Zn	Fe	Cu	SiO ₂
Mill feed.....	76 00	100 0	9.5	7.8	7.6	7.0	7	38.0
Lead concentrates.....	11 40	15.0	25.0	40.5	10.0	11.6	1.5	5.5
Zinc middling.....	9 50	12.5	13.0	5.5	20.5	10.5	9	17.0
Tailing.....	55 10	72.5	2.0	5	2.6	5.0	.1	52.0
Division of mill pulp:								
To jigs.....	40 28	53 0						
To tables.....	35 72	47 0						

RECOVERY AND METALS ACCOUNTED FOR

Products	Per Cent.					
	Silver	Lead	Zinc	Iron	Copper	
In lead concentrate.....	54	78	20	25	33	
In zinc middling.....	23	5	34	18	16	
In tailing.....	15	5	25	51	10	

the lead concentrate bins, and the spigot discharge to the classifier, which grades the ore into five sizes, the coarser going to two tables and the medium and finer to three tables. These tables make a finished lead-iron concentrate and a zinc middling and tailing. The lead-iron concentrate is discharged into the concentrate bin with the finished lead product from the jigs. The zinc middling is conveyed by a launder to the sand pump and discharged outside the mill awaiting further treatment, and the tailing passes into the main tailing launder and thence to the creek. The silver recovery is 76 per cent., and that of the lead, 85 per cent.

Recent time tests show a capacity of 3½ tons per hour, with none of the ore-dressing machinery running full. The jigs and tables easily handle this amount of material and would not be overloaded with 4 tons an hour.

To operate this mill requires two men on each shift, or six for the 24 hours, one crusherman on the day shift and a superintendent. The total milling costs per day are:

One superintendent.....	\$ 6.66
Three mill men at \$3.75.....	11.25
Three mill men helpers, at \$3.....	9.00
One crusherman.....	3.50
Supplies, repairs, renewals.....	5.00
Miscellaneous expense.....	2.00
Total for 24 hours.....	\$37.41

When treating 75 tons per day, the usual average, the milling cost is 50 cents per ton.

Table 1 is a general average of all the Montezuma Tam O'Shanter mill products taken over a period of 60 days; also the division of products for the same period. The recovery of zinc-iron and copper were less on account of treating air-oxidized ore from near the surface.

Personal

Philip D. Wilson, formerly of the Copper Queen mine, Bisbee, Ariz., is now with the Transvaal company at Cumpas, Mexico.

Arthur D. Little, chemist and engineer, president-elect of the American Chemical Society and president of Arthur D. Little, Inc., Boston, Mass., has been nominated by the Alumni Association of the Massachusetts Institute of Technology as a member of the corporation.

Norman Fisher has been elected president of the Cobalt branch of the Canadian Mining Institute. A. A. Cole was reelected secretary.

Charles Butters, president of the Butters Filter Co., is now examining his Salvador mines in Central America.

T. Lane Carter, of Chicago, recently lectured on "Mining in Africa" to the students of Yale University.

W. M. Drury, manager of the mining department of the American Smelting and Refining Co., has returned to Chihuahua, Mexico, from a visit to the United States.

S. T. Wellman broke his leg while on the Pacific coast examining the Heroult works of the Noble Electric Steel Co.

W. Gus Smith, mine manager, of Corbin, B. C., is in Eastern Pennsylvania, examining the method of stripping in the vicinity of Hazleton with a possible view of adopting similar methods.

George A. Guess, M. A., has been selected for the new chair of metallurgy at the University of Toronto, Canada. Mr. Guess has several years experience in concentrating and smelting work with Greene Cananea, Tennessee Copper Co., and Cerro de Pasco Mining Co., consequently is eminently fitted for the professorship. He is a graduate of Queens College.

Wm. S. Sutton, of the California Gold and Copper Co., Von Trigger, Cal., is visiting at his old home in Wilkes-Barre, Pa.

W. H. Blatchley, recently of Tonopah, Nev., is now with the new mill of the Santa Gertrudis Co., at Pachuca, Mexico.

H. W. Turner has returned from Siberia and is in San Francisco.

Edwin Ludlow has been appointed second vice-president of the Lehigh Coal and Navigation Co., with headquarters at Lansford, Pa. The office of general superintendent, resigned by Mr. Baird Snyder, Jr., on January 1, has been abolished. Mr. Ludlow in addition to other duties will have the supervision of all of the

company's collieries. Mr. Ludlow graduated at Columbia School of Mines, and was assistant engineer under his brother Gen. William Ludlow, in charge of the hydrographic survey and dredging work in the Delaware River. In 1881-1889 he was assistant superintendent and engineer for the Mineral Railway and Mining Co. at Shamokin, Pa. From 1889 till 1899 he was superintendent of mines for the Choctaw, Oklahoma & Gulf Railway Co., with headquarters at Hartshorn, Ind. Ter. From 1899 till January 1, 1911, he was general manager of the Mexican Coal and Coke Co., with headquarters at Las Esperanzas, Mex. Since January 1, 1911, until he accepted his present position, he was vice-president and general manager of the New River Collieries Co., at Eccles, W. Va. Mr. Ludlow has at various times been a valuable contributor to MINES AND MINERALS.

J. H. Cooper, formerly manager of the San Diego property at Santa Barbara, has been appointed superintendent of La Blanca mine at Pachuca, Mexico.

R. M. Raymond, of the Exploration Company of England, is in Santa Eulalia, Mexico.

Kirby Thomas, of New York, has gone to Mexican states on professional business.

Arthur Lakes is at Ymir, B. C., on consultation work for his son, Arthur Lakes, Jr., who is superintendent for the Ymir-Wilcox Development Co., Ltd.

C. Guy Warfel, who has been engineering various mining enterprises throughout Mexico, has returned to Denver, Colo., to recuperate from a severe siege of typhoid fever.

C. W. Merrill, of San Francisco, is in Colorado on filter-press business.

J. H. East, Jr., is superintendent of the Winona Gold-Copper Mining and Milling Co., developing an extensive tract of mineralized country in Western Wyoming. His address is Painter, Wyo.

Max W. Ball is chairman of the Metalliferous Deposits and Oil Lands Classification Boards of the U. S. Geological Survey, Washington, D. C. He has recently prepared a lengthy treatise on the coal-land controversies that are now occupying so much attention.

Hamilton Kilgour has recently made examinations of several Porcupine, Ontario, properties. At present, he is at home, East Orange, N. J., perfecting inventions of certain metallurgical improvements and mechanisms.

George E. Collins, of Denver, has been in London, Eng., several weeks on mining business.

R. Rodric Foster and J. Virgil Booth have purchased the engineering business of Lineberger & Rone, at Torreon, Mexico, and will do general mining and civil engineering work.

W. L. Affelder, superintendent of the Redstone Plant of the H. C. Frick Coke Co., at Brownfield, Pa., has resigned and accepted the position of general manager of the Bulger Block Coal Co., which operates a 1,000-ton per day mine at Bulger, on the Pan Handle Railroad, 23 miles west of Pittsburg. Mr. Affelder will reside at Crafton, Pa., a suburb of Pittsburg.

Robert Livermore, of Boston, has been appointed manager of the Kerr Lake Mining Co., Cobalt, Canada.

George Poore, of Scranton, Pa., formerly of South Africa, is now at Porcupine, Canada, a place which seems attractive to former South Africans.

Charles H. Henrotin, for some years superintendent at the Kimberley mines, South Africa, has been appointed superintendent of underground work at the Dome mine, Porcupine, Canada.

R. B. Brinsmade has moved his engineering office from Mexico City to Puebla, Pue., Apartado 185.

F. Julius Fohs, E. M., for the past seven years assistant geologist with the Kentucky Geological Survey has opened an office at Lexington, Ky., and will conduct a mining engineering business.

Charles Booth, who has been connected with the Chicago Pneumatic Tool Co. since its organization, has been appointed district manager of the company's New England territory with headquarters at 191 High Street, Boston, Mass., vice J. M. Towle, resigned. Mr. Booth, up to September 1, 1911, was vice-president of the company, at which time he was compelled to resign owing to ill health.

Shaft Raising in Hard Rock

Methods of Timbering, Drilling, Blasting, and Handling the Rock in Shaft

At the 16th annual meeting of the Lake Superior Mining Institute, S. J. Goodney, of Crystal Falls, Mich., presented an excellent and practical paper entitled "Raising Shaft on Timber in Hard Rock at the Armenia Mine," which is here reprinted.

breaking the air pipes or ladders, and with the chute nearly full all the time, it makes the ventilation excellent, as the farther the shaft was advanced the better the ventilation.

At first there were four miners on each shift of 10 hours each, with four hammer drills. The rock being a hard jasper and blocky, the progress was unsatisfactory. The hammer drills were taken out and four No. 3 Rand piston drills put in mounted on ordinary 8-foot shaft bars and clamps. Two more miners were put on each shift, making three men to two drills at each end of the shaft. The rounds consisted of 32 holes drilled 6 feet deep, as shown in Fig. 4.

All holes were fired with fuse, the electric blast was considered too heavy on the timber, the 16 cut holes being fired first. After trimming the roof, as shown in Fig. 5, a set of shaft timber was put in and lined up with the station set (all sets being lined from station set), and blocked securely. Flat timber was put on this new set with round maple lagging and secured the same as on the previous set. The tools were all passed up, and

the chute and ladder road extended. The remaining 16 holes, eight on each end, were then fired. The cut being already blasted out, these holes are not as heavy and do not affect the timber to any great extent. As much rock as possible from this blast was kept on the lagging, as shown in Fig. 6, to make the best possible protection for the new set of shaft timber from the cut holes of the next round. With this system progress was much more satisfactory, considering the hard and blocky nature of the rock. Three sets of 10"×10" shaft timbers and four studdles, making each set 4 feet 10 inches high, were put in weekly.

At the same time that the shaft raise was started, there was a heading driven 20 feet from the south side of the station, where a 5'×6' winze was sunk 30 feet. A drift was advanced along the hanging of the shaft from the bottom of this winze. When this drift had reached a point opposite the center line of the shaft it

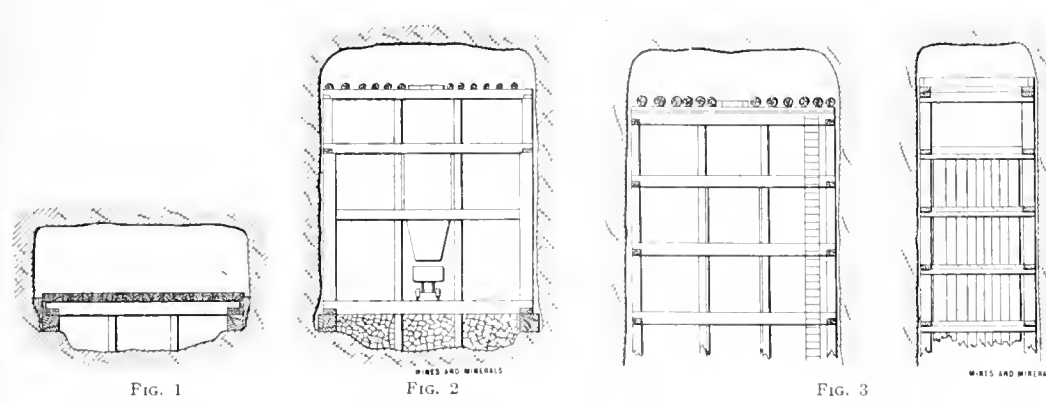

When the shaft was raised from the 7th level at the Armenia mine of Corrigan, McKinney & Co., the following method was used.

A winze was sunk a short distance from the main shaft on the 6th level where the best ore and least amount of water would be expected, and carried down 125 feet. Drifting was carried on from the bottom of the winze both ways at the same time; one drift to open up the new level so that when the shaft was completed the new level would be developed for some distance, the other drift going to a point directly under the shaft. At this point a room was opened up the full size of the shaft, and a sink cut taken up about 6 feet deep. The hitches were then cut and the shaft bearers put in, also the level set of shaft timbers. These were lined and squared with the transit, and the set blocked up solid and covered with 8-foot lagging of flat timber, as shown in Fig. 1. The ground above was then blasted down to make room for the station sets of the shaft. After these were in place, room was made and four sets of round timber put in the level station.

The shaft having three compartments, a rock chute was built in the center compartment by spiking plank on the inside of the divides, the plank being extended up to the second set from the top. By having one set open, as is shown in Fig. 2, it insures good ventilation. The north compartment was used as an airway and the south compartment for the air pipe, ladder road, and bucket way to hoist drills, tools, timber, etc. A small hoisting engine and $\frac{3}{8}$ -inch wire rope were used. The top set was covered with pieces of maple timber, 6 in. × 8 in., laid on top of the wall plates, as shown in Fig. 3, to protect them when blasting. The shaft was lagged over on top of the flat timber with 10-inch round maple timbers, hewn off a little on each end to prevent rolling. A 2-foot space in the center was left open for the broken rock to pass through into the chute, and for the miners to pass up to their working places. Two pieces of flat timber were put in between the round timber, one at each end, and spiked to prevent the lagging getting out of place when blasting. With the ladder road covered in this manner the danger to the men in going up the shaft after a blast is reduced to the minimum. By tramping enough rock from the chute so that it will hold all the rock from one blast, there is no danger of

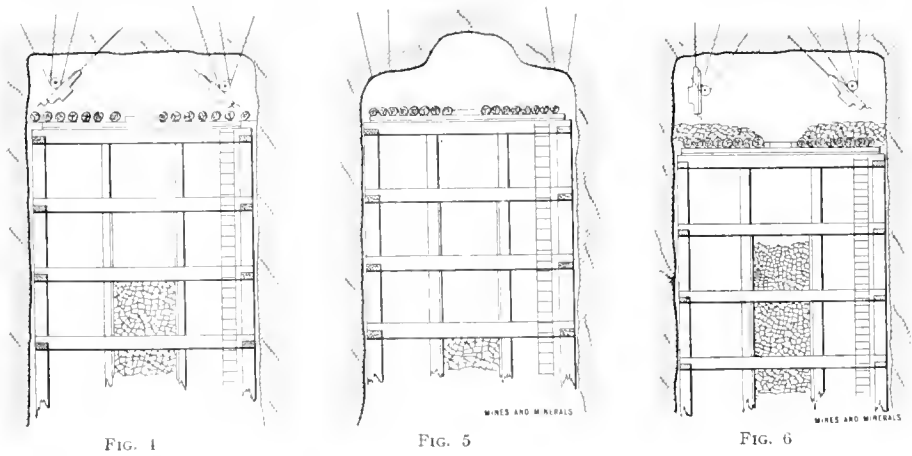

was turned at right angles for about 10 feet, and a small raise put up. By the time this raise was holed to the level, the main-shaft raise had advanced to a point where a 6-foot test hole was drilled through into the bottom of the shaft above. On being certain that there was only 6 feet of rock between the raise and the bottom of the shaft above, as shown in Fig. 7, the last round of holes was drilled accordingly, and let stand until all was ready to fire them. The timber in the raise was extended up as far as possible, so that when the pillar was shot out it would take only one set of timber to fill the space between the new and old shaft timber. The top

set in the shaft was then lagged over and blocked up solid. Then the tools were sent down, the broken rock trammed out of the chute, and the chute plank taken out; also the shaft raise cleaned down and skip sump stripped, and the broken rock passed through the small raise, where it was trammed with a bucket on a truck and hoisted up to the level through the winze. After completing the sump the skip runners or guides were put in, the chutes built, the car dumps put in, and everything completed. The pillar was shot out at 11 o'clock Saturday night and on the following Monday at noon all was ready to hoist ore, only delaying the hoisting 5 hours.

As stated, the drift from the bottom of the small winze was driven along the hanging wall side of the shaft. Fig. 8 shows the

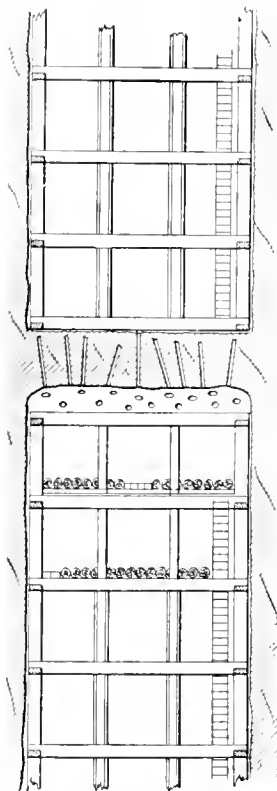

FIG. 7

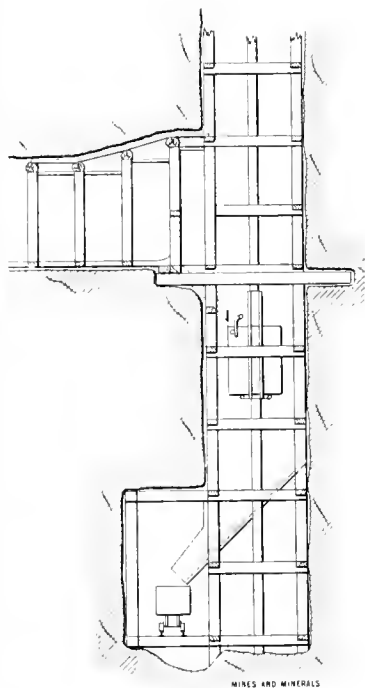

FIG. 8

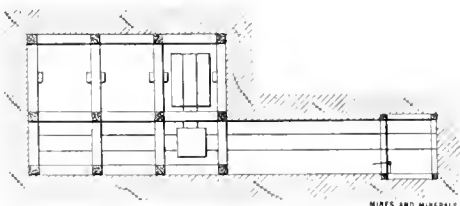

FIG. 9

reason for this, also the arrangement for cleaning out the skip pit of all ore or rock that may fall into the shaft from the skips being overloaded. The chutes can be emptied at any time without interrupting the hoisting of ore, as it is not necessary for any one to be in the shaft. This eliminates the overtime, as this work was usually done after 11 o'clock on Saturday night. Two men can now do the work in the same time it took eight men before. The cars are run under the chutes and loaded the same as at any other chute, and then run to the turn sheet and put on the cage, as shown in plan, Fig. 9, hoisted to the next level 30 feet above, and then run back and dumped into the skip. In case the cage is in use lowering timber, or otherwise engaged, there is a truck and bucket to hoist the material through the winze, dumping it in a car as usual. This, of course, takes two more men, one to land and dump the bucket, and one to run the small hoister.

Electrolytic Assay of Gold Solutions

The following paper was read by C. Crichton, F. C. S., at the September, 1911, meeting of the Chemical, Metallurgical, and Mining Society of South Africa on "The Assay of Gold-Bearing Cyanide Solutions":

Some four years ago Mr. Erskine, chief metallurgist to the Kleinfontein Group, had his attention drawn to an article in an Australian journal, giving a description of an apparatus for the assay of gold-bearing solutions by electrolysis, and as this method, as opposed to the usual precipitation or evaporation processes, seemed to indicate a great saving in labor and time expended, he decided to give the method a trial.

The results obtained from the first experimental run were in every way satisfactory, and during the four years in which, at the Kleinfontein Group Central Administration Assay Office, this process has been in constant use, no inaccuracies in the results obtained have been detected. From time to time check assays of the solutions have been made by means of evaporation with litharge, the values shown by the two methods being identical.

The estimation of metals by means of electrolytic deposition is in general use in most laboratories, the only difference between the determination of gold and, say nickel or copper, by this means being that in the latter case the increase in weight on a platinum cathode is noted, and in the former a lead cathode is used and the gold obtained by cupellation.

The apparatus at present in use at the above assay office consists of four oblong frames, 2 feet 10 inches by 3 inches by 6 inches,

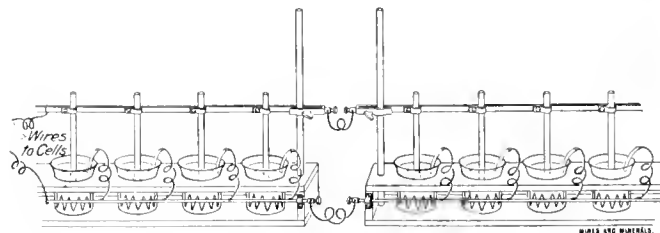

FIG. 1

connected in parallel, and each holding eight beakers. The frames or boxes are provided with two copper rods, as seen in Fig. 1.

Anode Connection Rod.—The anodes consist of ordinary $\frac{1}{8}$ -inch arc-lamp carbons, and are held in position in the center of each beaker by means of clamps fitted to a horizontal copper bar which runs parallel to and 6 inches above the top of the box. By means of a slot and thumbscrew the anode connection rod is attached to two uprights fixed at either end of the box, so that each section of eight carbons may be either lifted clear of the beakers or lowered, as required, in one movement.

Cathode Connection Rod.—This runs along the front side of the frame, slightly above the top, and about 2 inches from it; at suitable intervals along the rod are soldered eight single flexible insulated wires, forming a connection for the lead cathodes.

Description of the Cathodes.—The cathodes are made from ordinary assay lead foil, a suitable length being 9 inches, and as the foil is usually obtained in strips 36 inches long, a good quantity of the necessary lengths can be obtained in a short time by cutting the strips of foil into four equal portions. About a dozen of the lengths are placed together and \wedge shaped pieces cut out from along the edge intended for the bottom of the cathode, this is to allow for the better circulation of the ions through the solution. Arrangement has to be made for connecting up the flexible wire from the cathode rod; for this purpose a strip about $\frac{1}{4}$ inch broad is all but severed from one end of the foil, and is folded over, forming a terminal. The two ends of the lead are now brought together and connected by folding the edges; to ensure a smooth surface and circular shape, a glass bottle having a slightly smaller diameter than the inside of the beakers in use will be found to be convenient for this operation. Very little time is occupied in making the cathodes,

a native can, during a very few hours, make a sufficient number for 200 or 300 assays.

The necessary current for the deposition of the gold in solution on to the cathode is obtained from three 2-volt accumulator cells, which being connected in series give a terminal pressure of just over 6 volts. The amperage varies, of course, with the resistance offered by the solution through which it passes, i. e., the stronger the solution is in KCN the greater will be the amperage. For example, a solution having a strength of .3 per cent. KCN passes .1 of an ampere, and a slime solution (.02 per cent. KCN) will take a current of about .04 ampere. The accumulators are charged from a direct current lighting circuit through a suitable lamp resistance, and connection can be effected between the lighting circuit and accumulators, or accumulators and electrolytic apparatus, as desired, by means of two-way switches.

Having roughly described the apparatus, little remains to be said except that perhaps a few details regarding the *modus operandi* may be of interest. The usual number of solutions assayed each day is 22; these are sent up in marked bottles from the cyanide works at 6 A. M. and 10 A. T. portions are at once measured out from each bottle and placed in beakers belonging to the apparatus, which are prepared the previous evening, so that as soon as connection is made no further attention is required. The time required for the complete deposition of the gold is 4 hours, after which period the carbons are removed clear of the beakers, the current is switched off and the lead cathodes disconnected and removed to a hot plate to dry; when dry, these are folded into a small compass and cupelled with a little silver, parted and weighed, the values being reported to the cyanide works manager by 11 A. M. Although from start to finish this process occupies about five hours, only a few minutes are expended in actual personal attention, and the measuring out of the quantities of solutions can be done either by the cyanide works shiftsman, or, as in our case, by the reduction works sampler. I might mention that if 20 A. T. of solution is required for use instead of 10 A. T., the same time only is necessary for the complete deposition of the gold on the cathodes.

Precautions should be taken against having the carbon anodes in contact with gold-bearing solution in the absence of any current passing through. Negligence in this particular results in gold being precipitated on the anode.

In the event of a solution offering too great a resistance to the current, the addition of a small quantity of KCN will remedy this, and accelerate the deposition of gold.

It has also been found advantageous to add a little ammonia to solutions which deposit salts.

I regret that I cannot give the name of the author to whose article I have already referred, neither have I the name of the journal in which it appeared, and unfortunately at the moment Mr. Erskine, who could probably supply the information, is away on leave.

來 來

The Perversity of Miners

It has been found by investigators that dust made from drilling dry holes in quartz mines will cause pulmonary disease, and that dust from some lead mines will poison the miners. To lessen the danger from these sources the Queensland Mines Regulation Act has adopted rules that make it obligatory for the managers of ore mines to furnish jets or sprays allaying rock dust, and also respirators where men must work in dusty places. The rule is: "In ends, or rises, and as far as practicable in other places, no person shall, where water is available, remove, or cause, or allow to be removed, the rock broken if dry and dusty, unless it has been effectively dampened so as to prevent the escape of dust into the air during the movement." Although the miners strongly advocated these innovations, so soon as they were incorporated in the Mines Regulation Act they showed complete apathy as to their use.

As the law compels the managers to see that the rules are enforced, and the men for various reasons of their own will not carry out instructions in this regard, there seems to be a deadlock due to the perversity of the miners. The attitude of the men is said to be due

to the increased humidity of the atmosphere that causes inconvenience and loss of time, the dust sticking to everything. In steep rises where the sprays have been successful in laying dust the claim is that they cause too much discomfort. Previous to their introduction pails were provided at some mines that miners might have water to allay the dust, but they refused to carry the water a short distance, although they knew it was for their best interest. Trouble, loss of time and indifference on the part of the men seem also to be the main factors accounting for the apparently general disinclination to use water for laying dust underground. Even where water is laid in pipes so as to be conveniently handled as possible, the men in most cases do not use it as it should be used.

Complete provision is made in the Act with respect to the attitude of the men by making it a punishable offense if any person wilfully refuses or omits to make use of the means provided for laying dust or otherwise safeguarding health.

來 來

Lake Superior Copper Notes

Ahmeek Mine Development.—Development work in the Ahmeek mine during 1911 made five levels of new ground at both No. 3 and No. 4 shaft. No stoping has been done on these levels, and the sixth and seventh levels have been extended to the boundary of the Mohawk property. It is assumed that the mine will expend large sums in development and equipment including an addition to the mill which contains four stamps. With but three stamps working, Ahmeek produced 15,000,000 pounds of copper in 1911.—T. C. N.

The Tamarack Mining Co.'s Existence.—A special meeting of the stockholders of the Tamarack Mining Co. was held January 2, 1912, for the purpose of considering the continuance of corporate existence of the company for a term of 30 years. There were 45,411 shares represented at the meeting, all voting in favor of the motion. The Tamarack has not paid a dividend since 1907, which, however, does not signify it may not in the future. It is an historical mine that at present has \$1,052,000 assets on hand.

The Copper Share Market.—The recent advance in Calumet and Hecla stock carried up four of its subsidiaries, the Ahmeek, Allouez, Centennial, and Isle Royale. On May 1, 1911, the Calumet and Hecla owned 21,800 of the 50,000 outstanding Ahmeek shares. Since the lowest point reached in 1911 the 40,000 odd shares of the Allouez have increased in value 114 per cent.; the 44,000 odd shares of the Centennial 134 per cent.; and the 27,500 shares of Isle Royale have increased 100 per cent. in value.

Representation vs. Taxation.—A list of the securities deposited with the New England Trust Co. to satisfy judgment obtained by the Old Dominion Copper Mining and Smelting Co. is wanted by the Tax Commissioner of Michigan for taxation purposes. These securities were deposited by A. S. Bigelow in lieu of a bond at the time the Old Dominion won its suit for \$2,250,000 last year. If these securities are found taxable, the assessment must be paid by the interest finally winning the suit, which has been appealed to the United States Supreme Court. In the event that the Old Dominion wins the suit these securities become the property of the company. Pending a determination of the taxation question the parties in interest will not disclose the nature of the securities deposited which are understood to be a miscellaneous character including mining shares.—C. T.

The Franklin Mine.—The Franklin mine is about ready to go into operation under the new order of things, with new and enlarged equipment at the mine, and the remodeled and improved mill—the equal of any—for the economical handling of rock, and to secure a full average recovery of the copper in the rock. The new machinery is probably tuned up by this time and in readiness for full duty. The openings for several levels disclose highly mineralized ground, carrying considerable mass and barrel copper, natural to the Pewabic lode. With the new equipment at the mine and the improved mill, to treat the rock and obtain a full average recovery the new Franklin should make good.

Treating Zinc Crusts and Drosses

Treatment of Gold and Silver Crusts—Cupellation—Retort Dross Parting—Refinery Drosses

By William Poole, B. E.*

This article is the last one to be abstracted from the paper read by Professor Poole before the Sydney University Engineering Society and entitled "Treatment of Broken Hill Ores." Those who have back numbers of MINES AND MINERALS, dating from November, 1911, are fortunate, as they possess a practical treatise on metallurgy. Professor Poole has written on his own as well as the latest practice in the treatment of lead-zinc ores carrying gold and silver. MINES AND MINERALS thanks Professor Poole for kindly permitting its readers to have the benefit of his writings.

Gold Crusts.—The pressed dross skimmings from the special gold pan are not retorted, but treated direct with litharge in a cupel furnace, in which most of the zinc is burned off. About 1,200 pounds of this gold crust is treated per shift, in lots of 400 pounds each. Before each lot is fed in, the crust, known as "gold sweatings," is skimmed off, and sent for further treatment to the blast furnaces on refinery products, and part of the bullion is laded out and sent to the concentrating cupels.

The gold-zinc alloy obtained from the "special gold pan" is sent to the retort furnaces, where it is fed into the retorts, and retorted for about 12 hours. The condensers are removed, and the zinc which has been recovered is returned for further use in the zinc pans. The dross is removed from the retorts, and, together with the dross obtained in the previous partial retorting, is treated on sweat cupels. Retort bullion contains: Gold, 12 ounces per ton; silver, 250 to 300 ounces per ton. Retort dross contains: Silver, 120 to 130 ounces per ton; lead, 60 per cent. The bullion is dipped out into molds, and concentrated in cupels to about 16,000 ounces *Ag* per ton; 480 to 640 ounces *Au* per ton.

The bullion is then dipped out and refined in another cupel, and afterwards dried, as explained in the production of silver bullion. The doré bullion is placed in the strong room until sufficient has been collected to run the parting plant, where it is treated toward the close of each half-year. Gold contents about 30 to 40 ounces per 10,000 ounces doré bullion.

Treatment of Silver Crusts.—A charge of 1,200 pounds of silver zinc crusts are treated in a retort. The products are distilled zinc, dross, bullion, a small amount of blue powder, and fume. The bullion is cupelled and the dross treated in the "retort dross furnace."

Retort bullion contains, silver, 3,000 to 3,500 ounces per ton; gold, trace; zinc, 1.3 to 3.3 per cent. The retort dross contains, silver, 2,200 to 2,500 ounces per ton; lead, 55 to 60 per cent.

The bullion is equal to about 34 per cent., the dross to about 3 per cent., and the condensed zinc to about 10.5 per cent. of the charge.

Coal consumed equals about 15 per cent. of weight of alloy treated.

Cupellation.—The cupellation is undertaken in furnaces of the English type—that is, like a small reverberatory furnace, the hearth of which has a replaceable bottom cupel, or "test," as shown in Fig. 1. The furnace is fired with coal on a hearth on one side.

* Director Charters Towers School of Mines.

The flame and products of combustion pass across the minor axis of the test, and run down a flue at the other side. The test frame is an elliptical iron pan 5 feet by 4 feet by about 12 inches deep. The pan is lined with a filling composed of: Marble, 300 pounds; limestone, 120 pounds; Portland cement, 120 pounds; and fireclay, 60 pounds. All the constituents are finely ground and well mixed. The mixture is moistened and thoroughly tamped into position. The well of the test is formed by placing an inverted mold in proper position, and well tamping the filling round it. After the mold has been removed the outlet gutter is cut. The width of the top of the filling is here about 9 inches, and at the far side about 4 inches. The tests are covered over with wet bags for some time, and stacked in a warm place for several months to become thoroughly dry.

The tests for the concentrating cupel are water-cooled around the rims by a 1-inch water pipe, which enters near the outlet, passes right around, and is bedded in the upper portion of the side of the test. There is also a water-cooled outlet. A tuyere, with a horizontal slit nozzle directs a current of air on to the bath of molten metal. The litharge, as it is formed, is blown across the outlet, and a fresh surface of metal exposed to the air-current. The molten litharge runs continuously from the outlet into slag pots. The bath of metal is kept to its proper height by feeding fresh bars of bullion through a door especially arranged for that purpose. When the bullion has reached the desired concentration—viz., to

about 50 per cent. silver, the blast is taken off, and the bullion is dipped out into molds and taken to the refining cupels. Concentrating cupels give about 1,800 pounds of litharge and 25 to 30 bars of bullion per shift of 8 hours. Part of the litharge is kept for treatment in the retort dross furnace, and the rest sent to the blast furnace on refinery products.

The concentrated bullion is now further concentrated to crude silver in another cupel furnace, the test of which is similar to the previous, except that it is shallower and not water-cooled around the edge. The outlet, however, has a water-cooled block. The con-

centration is continued until the silver has very little lead in it. It is then dipped out into tapered rectangular molds, containing about 1,000 ounces.

The crude silver is further refined or "dried," on a finishing cupel similar to the former, except that no outlet is used. The test used is one that has never been used before. It is afterwards used for the preceding operation. After the silver has been melted down, a little lime or dry test composition is thrown on the surface. The fire is then strongly urged and the last trace of lead is volatilized or absorbed by the powdered lime or composition. The latter is gathered into a ball, and removed by an iron bar. The refined silver is dipped out into hexagonal molds, containing about 700 ounces. The molds are of a different shape, so that the bars of "dried silver" are not mistaken for those of "crude silver." The top of the solidifying ingot is stirred to prevent undue frothing and spitting during the cooling of the silver.

During the molding a sample for assay is taken by pouring a little from several ladles into a pail of water. This rough-cast silver is almost pure, and has a "fineness" of about 998.5 to 999.2.

Remolding of Silver Into Market Bars.—The rough hexagonal ingots are remelted in plumbago crucibles, about 2,050 ounces to the charge, and cast into two brick-shaped bars, slightly tapered to one side, weighing about 1,020 ounces each, and a sample for assaying poured into water. A little pure copper is added to each charge to bring the "fineness" of the silver back to 996.0 or 996.2,

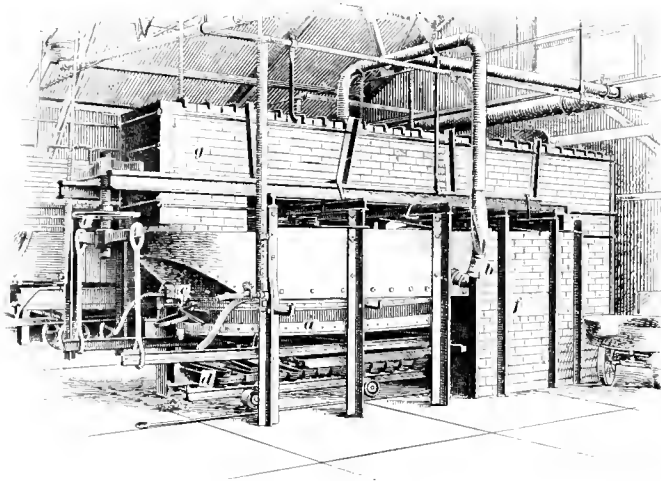

FIG. 1. CUPEL FURNACE

as greater fineness than 996 is not paid for. The freshly poured bars are skimmed, and when solidified turned out of the mold and plunged into water. The bars are freed from rough excrescences of surface by chiselling, scraping, and filing, the edges being slightly rounded. The upper surface and one end are hammered all over. Upon the hammered end is placed the company's brand, number of batch, number of bar, fineness of silver, and weight to the nearest half ounce. The silver bullion is sent away once a week in lots of about 100,000 ounces, its destination usually being India or China.

Treatment of Retort Dross.—The retort dross is stored and treated periodically in a reverberatory similar to those for treating lead in softening and refining.

The retort dross is treated with litharge and fine coal. A bath of about 5 tons of lead bullion is first melted down, otherwise the dross sticks firmly to the bottom of the furnace hearth. A charge consists of: Retort dross, 750 pounds; litharge, 500 pounds; fine coal, 25 pounds. Four charges are added for each 8-hour shift, producing from 2,200 to 2,300 pounds of slag, which is removed once a shift in a similar manner to a skimming from a softening furnace. The bullion is tapped periodically into a small lead kettle, and then bailed out into molds. This bullion is very rich in silver, and is cupelled without any intermediate process.

The slag, known as dross furnace slag, is sent to the blast furnace on refinery products. The products approximately contain:

Bullion—Silver, 3,000 ounces per ton.

Slag—Silver, 300 ounces per ton; lead, 50 per cent.; zinc, 34 per cent.

Parting.—The doré bullion is parted by the use of Gutzow's modified process, which, in brief, is as follows: The doré bullion is treated in cast-iron kettles, with a considerable excess of strong sulphuric acid H_2SO_4 . The silver goes into solution as sulphate and the gold remains as metallic gold sludge. The strong acid and dissolved silver sulphate is siphoned off into a vat. The liquor is kept hot, and diluted by passing steam into it, and then cooled, the silver sulphate crystallizing out. The liquor is drawn off, the silver sulphate crystals washed, dried, and reduced by a small amount of carbon in a cupel to metallic silver. The gold sludge is further treated with H_2SO_4 , washed, treated with hydrochloric acid HCl , washed, and smelted into bars. There are three kettles of soft cast iron, 2 feet 10 inches by 2 feet 9 inches deep and 2 inches thick, and with a rim 5 inches wide around the top. This rim rests on cast-iron plates 2 inches thick, which in turn rest upon the brickwork of the furnace. There is a gutter around the edge of the cast-iron plate to catch any acid liquors which may be spilt, or in case the charge boils over. The gutters lead into a launder, which discharges into a lead-lined vat. Each kettle is separately fired from underneath. The bottom of the ashpan is of cast iron, sloping to one side, so as to catch any solution which may leak through should a pot crack or break. The kettles have cast-iron conical-shaped covers, as shown in Fig. 2, which have a 12 inches by 8 inches working door in the side. The top of each cover is connected by a large lead pipe leading to the top of a lead-lined condenser, 16 feet long

by 3 feet 6 inches broad. Another lead pipe leads from this condensing chamber to a tower 10 feet high by 2 feet 6 inches by 2 feet 6 inches, filled with coke. A 4-inch diameter pipe leads from near the bottom of the tower to a flue leading to the main stack, which produces the suction for the draft. The vaporized acid liquor which boils off from the kettle is caught in the condensing chamber of the tower, any uncondensed acid vapor passing to the main stack. A small lead pipe leads from the bottom of the condensing chamber, and another from the cooling tower to a lead-lined vat, in which the liquor is concentrated to 58 degrees Baumé by means of a steam coil. The concentrated liquor is then elevated to the mother liquor tank for further use. Charges are run down in the first and third kettles, and the gold sludge afterwards sweetened in the second kettle.

A charge for each running down kettle consists of four bars of doré bullion, containing 4,000 to 4,800 ounces. About 600 pounds of fresh, strong H_2SO_4 is now run in from the acid storage vat. The acid is first passed into a measuring tank, so that the quantity can be properly gauged. It was found that granulated doré bullion caused too much frothing, so it is charged in large bars. The fire is then started, and urged strongly until the action is brisk. It should then be kept going at a steady rate until the whole is dissolved. The contents of the kettles are then allowed to cool down. When cool enough another liquor of 55 to 58 degrees Baumé is run into each kettle, until they are within 4 inches of being full, the whole being well stirred, so as to thoroughly mix the strong, thick sulphate of silver solution with the mother liquor. The fires are then restarted, and the contents of the kettles strongly heated. The gold sludge is now carefully removed in an iron ladle, draining it as free as possible of silver solution. The ladle is then passed into the sweetening kettle (which is half full of strong acid), and depressed below the surface of the acid before emptying, to prevent splashing. As much of the gold sludge is removed as possible. The running-down kettle is then steadily fired for a couple of hours,

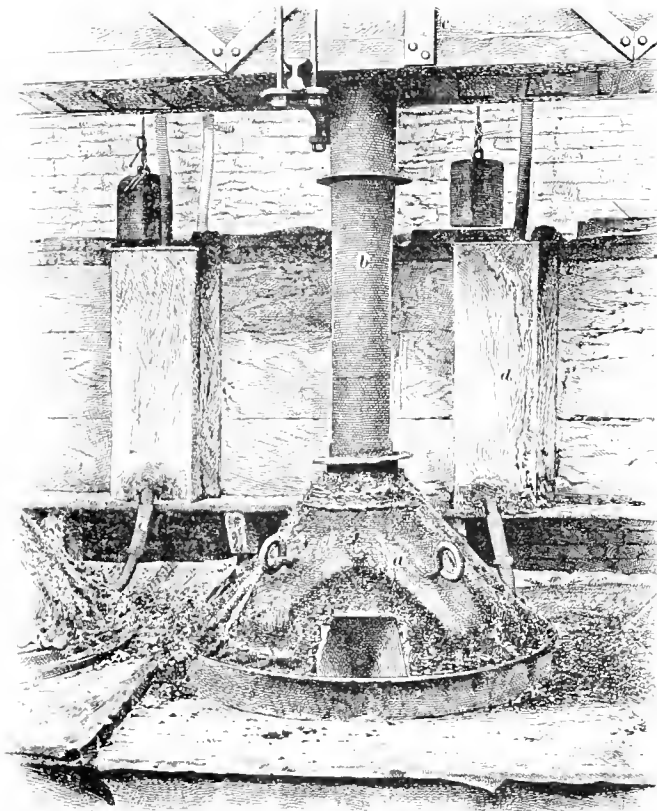

FIG. 2. UPPER PART OF PARTING KETTLE

until the liquor is hot enough to run down into the pans, when the solution is allowed to stop boiling, and is carefully siphoned through an iron pipe into settling pans. These pans are of cast iron, 6 feet by 3 feet by 18 inches deep, with an outlet hole 1 inch above the bottom. The object of the pans is to retain any gold which may have been drawn over from the kettles. Prior to the liquor being siphoned from the kettles, the pans have 4 to 6 inches of mother liquor run into them, with the object of loosening the small amount of crystals which form from the previous day's work when the pan gets cold. After standing for half an hour the liquor is run off into the crystallizing vats. These vats are of the same material and size as the settling vats, and are placed in another vat of cast iron, leaving a 3-inch space round the sides and under the bottom. This space is for circulating cooling water. The crystallizing vats have a half-inch diameter lead pipe reaching to within 1 inch of the bottom. The pipe is drawn to a nozzle. These pipes are used for steaming up the solution and also for reducing the strength of the silver sulphate solution.

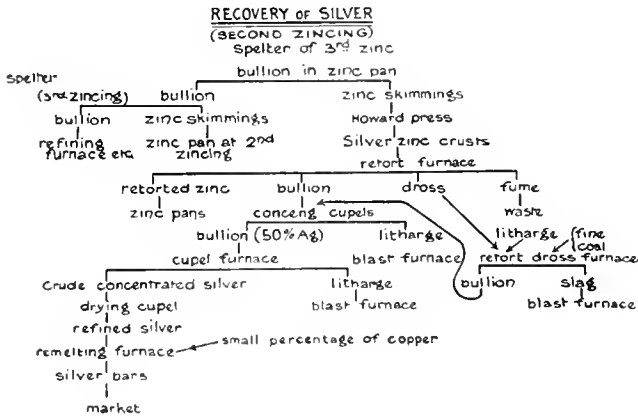
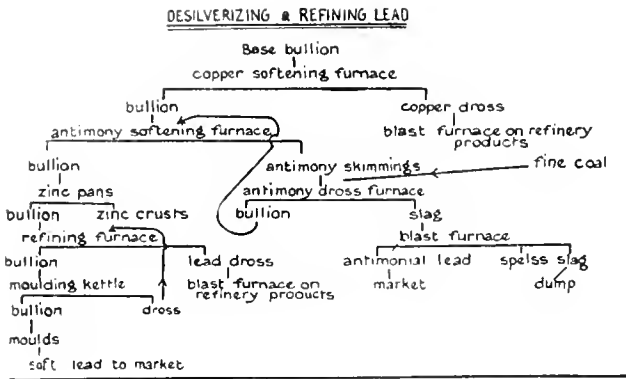

FIG. 3

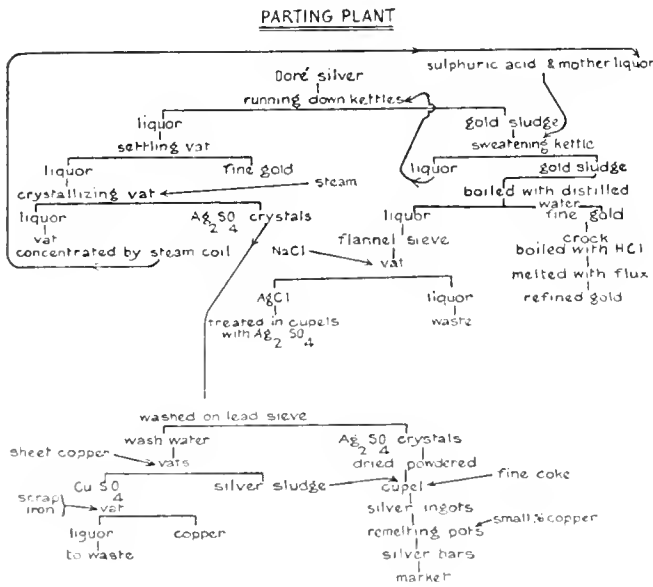
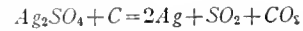

FIG. 4

When the solution in the kettle is ready for siphoning the steam is turned on rapidly to heat the liquor already in the crystallizing vat. The liquor is then siphoned off from the kettles, and allowed to stand in the settling vats from 10 to 20 minutes to allow gold sludge to settle. During this time the kettles are recharged with doré bullion and strong acid. The liquor is then run from the settling vat into the crystallizing vat, and the steam quickly turned on. Before steam is turned on, the liquor should be about 64 to 65 degrees Baumé. When it has been reduced to from 61 to 62 degrees the steam is turned off, and the pipe removed. Wooden bars, from which are suspended 2-inch strips of sheet lead, are then placed across the vat. These strips reach nearly to the bottom. Silver sulphate crystals form on these strips, and prevent a too large crop forming on the bottom. After the pan has been cooling for about an hour the circulating water is turned on, and left running all

night. By morning the greater part of the silver sulphate in solution has crystallized out. The outlet is then opened, and the liquor drained into a lower vat, where it is concentrated by a steam coil, and then elevated to the mother liquor supply tanks. The crystals are removed from the strips to a lead sieve in a washing box, and washed about five times with cold, fresh water. The wash water runs into lead-lined wooden vats, where the small amount of silver sulphate dissolved in the water is precipitated as silver sludge by means of sheets of copper. The copper sulphate is afterwards recovered as cement copper by means of scrap iron.

The washed silver sulphate crystals are dried, powdered, mixed with about 6 per cent. of fine coke, and reduced in an ordinary cupel furnace to metallic silver, which is skimmed and molded ready for remelting. The reaction is



The silver precipitated in the wash-water vat is collected and washed free from acid and copper sulphate solution on a lead sieve with hot water, dried, and mixed in the charge with the silver sulphate crystals.

When a fair quantity of gold (500 to 1,000 ounces) has accumulated in the sweetening kettle, it is boiled five or six times of about 2 hours each, with about 300 pounds of H₂SO₄ acid until it shows only a trace of silver in solution. When working continuously the acid from the sweetening kettle was sent to the running-down kettle in a single run. At present it is stored for future use. When short runs are made, the sides and covers of the running-down kettles are carefully washed down with a broom, and the sludge transferred to the sweetening kettle, which is likewise carefully washed down at the end of the sweetening. The gold sludge is carefully removed to

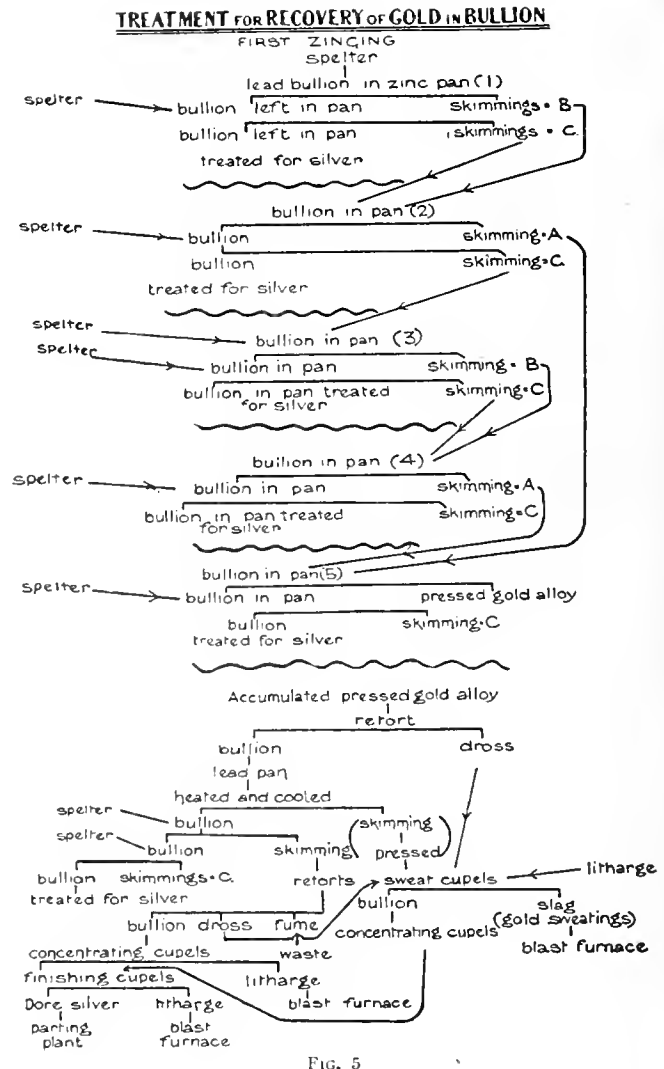

FIG. 5

a lead-lined wood vat and boiled up with distilled or condensed water by means of a steam coil. It is boiled for 30 to 45 minutes, and then allowed to settle for the same length of time. The liquor is siphoned off through a flannel sieve into a similar trough, where sodium chloride $NaCl$ is added to the liquor, to deposit any silver as silver chloride $AgCl$, which is run down in the cupel with the silver sulphate. The liquor is siphoned off through a flannel filter into the waste drain. Another lot of condensed water is added to the gold residue tank, boiled, and siphoned off as described above. These boilings are continued until the water is free from silver, after which it receives two boiling washes. The gold residue is then carefully removed, and placed in a large earthenware crock, hydrochloric acid is added to remove any iron, lead, etc., remaining, and the liquor is heated by steam for a few hours. The acid is decanted off through a flannel, the gold transferred to a flannel filter, washed several times with boiling water, and dried. The flannel filters used to catch gold residue are afterwards burnt in the crucible when running down the gold. The gold is smelted in plumbago pots, using borax, nitre, and common salt as a flux. The slag is skimmed off, and the gold poured on to bars of about 400 ounces each. A sample is granulated for assay. Fineness, 995 to 997.

Treatment of Refinery Drosses.—Drosses and by-products not specially treated at the refinery are sent to the blast furnaces, one of which is specially set apart for their treatment.

The principal refinery by-products treated in this way are: Copper dross from the copper softener, lead dross from the refining furnace, litharge from cupel furnaces, and dross furnace slag. These are added as an extra of from 800 pounds to 1,600 pounds to the ordinary blast-furnace charge. The addition of these by-products has the effect not only to increase the output of the blast furnace, but also enables the furnace to treat a larger tonnage of ordinary charge per day. A small amount of 10 to 15 per cent. copper matte is produced during the treatment of the copper dross.

Fig. 3 shows diagrammatically the process of desilverizing and refining lead, and of the recovery of silver. Fig. 4 shows the process used in parting plant, and Fig. 5 shows the treatment for the recovery of gold bullion.

采 采

Ore Mining Notes

The Thompson-Gamey Silver Property.—This property is near Spawning Lake, in the Elk Lake District, Ontario. For various reasons it was decided to try to reach the silver vein which outcropped on the surface by means of a cross-cut tunnel. After driving 600 feet an 18-inch vein of calcite and silver was found giving a depth of 225 feet of stoping ore to the surface.

Future of Cobalt.—Thomas W. Gibson, Deputy Minister of Mines for Ontario, in his review for 1911, says: "While it is quite possible that the climax of production may prove to have been reached in 1911, the indications are that for many years to come the Cobalt mines will yield silver in considerable quantities. Naturally the phenomenally rich ore at first obtained is now less in evidence, although by no means worked out, and more and more dependence is being placed on the low-grade concentrating material. This is shown by the fact that while the aggregate tonnage of shipments was less than in 1910, the shipments of concentrates increased from 6,874 tons to over 9,000 tons. Some of the high-grade ores are also now being refined on the spot." After reviewing the production of bullion in the camp he comments on the fact that the tendency toward the final treatment of ores in the camp, or at least in the province, was a strongly marked feature of the operations of 1911.

Tungsten Mineral in Porcupine.—At the formation of a branch of the Canadian Mining Institute in Porcupine, a few weeks ago, a paper on this ore was read by one of those present and greatly appreciated. Samples were passed around and the next day the mineral was found at several of the properties, including the Hollinger, where, in some places, it was found in large quantities. The United States in 1910 produced 1,607 tons, valued at \$550,000,

and this forms a goodly percentage of the world's output. At Porcupine the mineral was discovered for the first time in Ontario, although small deposits have been known to exist in British Columbia and Nova Scotia in the gold mines. Whether the deposits in Porcupine will be of commercial use or not remains to be seen.

Porcupine's Activity in Toronto.—The Dominion Stock Exchange of Toronto, decided on January 17 to suspend operations until the crisis brought on by the failure of the stock brokerage firm of E. D. Warren & Co. has subsided. The firm was promoting the Crown Chartered property in Porcupine. The stock fell from 47 to 13 and bounded to 20. There will undoubtedly be family crises owing to speculation in Porcupine and no rebound.

Coniagas Mine, Cobalt.—By the time that this is in print the fourth level of the Coniagas mine will have been reached by a winze driven from the 225-foot level to the 300-foot level. During the sinking of the winze the width of the vein was 3 inches of from 2,000 to 3,000 ounces of silver to the ton, while the wall rock contained the usual kind of milling ore found in the upper levels. According to Manager R. W. Leonard's report, the cost of mining during the year was 8.8 cents per ounce of silver. The total ounces of silver mined and shipped during the year were 3,789,274, and the cost of 8.8 cents per ounce includes mining, concentrating, assaying, treatment charges, office expenses, and royalties. The mill crushed during the year 52,320 tons of ore, and shipped 1,418.4 tons of concentrate containing 1,643,616 ounces of silver.

Zinc in Ontario.—Zinc minerals are found in Sesekinika and Dorrien townships, Ontario, but in what quantities it is impossible to say until more prospecting has been done. Zinc mining in Canada is handicapped, inasmuch as all ore has to be shipped to the United States for treatment, there being no zinc smelting plant in that country. The entry duty into the United States makes this shipping operation an expensive one, as the zinc miners of British Columbia have discovered. The United States is the largest user of zinc, the Steel Corporation using 75 per cent. of the total production, while the paint manufacturers create a large demand for zinc oxide.

Passing of Wernher, Beit & Co.—The disruption of the firm of Wernher, Beit & Co., which so long has held the whip hand in the production of diamonds and gold in South Africa, is due, it is claimed, to Sir Julius Wernher's infirmity, due to the weight of years. The bulk of the firm's mining business was transferred to the Central Mining and Investment Corporation, while a number of the share assets were taken over by Rand Mines, Limited. Sir Julius Wernher retains the chairmanship of the Central Mining Corporation. The diamond branch of the business is taken over by the other partners of the firm, under the name of L. Brietmeyer & Co.

Chilean Trade Notes.—Chile's copper exports for the first 9½ months of 1911 showed a loss of 3,500 metric tons (metric ton = 2,204 pounds) from the same period of 1910. Nitrate shipments of Chile to the United States during October, 1911, amounted to 480,300 quintals (quintal = 101.41 pounds) more than during the same month of 1910.

采 采

It Is to Laugh

In an article on "Saving Wood Waste" in the *Saturday Evening Post*, Forrest Crissey says: "In coal mines having horizontal shafts the cars are pulled out by a power cable; the return portion of the cable underneath the tramway rests upon a series of rough wood cylinders called mine rollers. Ordinarily the miners go out in the woods, cut young trees and then turn them in a lathe down to a diameter of 6 inches."

Mr. Crissey seems to know as much about mining and to express himself as positively as the general magazine writer who writes on industrial and sociological conditions in coal regions for some of the popular magazines. In justice to Mr. Crissey, however, it must be said that his article in the *Post* is not a criticism of mining conditions, but in the main is an interesting one showing how wood that was formerly wasted is now being utilized.

Shaft Sinking by Cement Injection

Apparatus and Methods Used in Sinking 262 Feet Through Running Ground in France

The following is an abstract from a paper on "Shaft Sinking Against Water in Fissured Ground by Cement Injection," by A. L. Shrager. Mr. Shrager presented his paper to The Institution of Mining and Metallurgy, and because of its importance and practical bearing on the subject of shaft sinking it is here reprinted:

Cement injection is now replacing to some extent the Poetsch freezing process for the sinking of shafts in water-bearing ground. It was developed in the chalky formation of the Pas-de-Calais coal field, but is equally suited for any fissured water-bearing rocks, although not for soft running ground such as quicksand. It consists of a number of bore holes of suitable dimensions sunk at equal intervals in the form of a ring surrounding the proposed site of the shaft. Cement and water, injected through these bore holes by means of a force pump, find their way into all the cavities and crevices of the ground surrounding each hole, in which the cement sets. As the cement from one hole penetrates the rocks surrounding it, that coming from the adjoining hole is encountered and a cemented, water-tight wall is formed around the proposed site of the shaft, and it is in this way that one is able to get rid of the water troubles that occur in the process of sinking. The equipment for this process is small and comparatively inexpensive. The cost of sinking by the cement injection process is only about one-third that of the Poetsch process.

Its practical advantage is that water is almost completely shut out, and the erection of a masonry lining, if necessary, is made more secure; indeed, the solid wall of concrete makes the lining almost superfluous.

The danger to shaft sinkers is greatly lessened by the employment of this method, as they have not to cope with continual water troubles when sinking, and, in the event of repairs to shaft lining being necessary later, the existence of the permanent cement wall practically shuts out all water from the shaft.

The particular shaft to which reference is now made was sunk at a coal field in the Concession of Lens, in the Pas-de-Calais basin, where the process has proved so successful that all the most modern shafts have been sunk by this method.

The section of ground through which the shaft passed was as follows, in descending order:

Earth, 16 feet 3 inches; chalk, 65 feet; chalk and flint, 118 feet 1 inch; sandstone, 131 feet; gray marl, 213 feet; blue marl, 262 feet.

Deeper than this the strata were strong and practically impervious to water; thus the process only required to be taken down to 262 feet.

A preliminary pit was first dug to facilitate operations and to afford a fairly solid stratum for inserting injection pipes. The pit was lined with masonry 2 feet 3 inches thick to an inside diameter of 24 feet 4 inches; and six bore holes, evenly spaced around a circle having a radius of 14 feet 3 inches, were then bored and injected with cement in successive stages.

Each hole was bored with a churn drill when encountering hard measures, but for soft, argillaceous strata, rotary auger drills were

used. The lining case *a* shown in Fig. 1, at the head of each bore hole was packed around with concrete *b* in order to prevent leakage around the upper end of the hole and to ensure the application of the full pressure of the pumps.

The lining case was made of steel 2 inches in thickness, with an inside diameter of 11.6 inches. Its upper end has a cast-iron head or plug *c* to which the necessary pipe connections were made.

An iron pipe *d* fitted with a pressure gauge and stop-cock enters the side of the casing just below the plug. During the washing of the hole which followed each drilling operation, this pipe carried off the muddy water, but as soon as the water came clear the pipe was connected to the cement mixer, in order that any excess of cement injected might be returned to the mixer and utilized.

For boring through the limestone the percussive system of drilling was used, which permitted of more rapid progress and quicker injection of cement than was obtainable by the lighter drills which were originally tried.

Special augers were employed for boring in the measures containing over 18 per cent. clay, as these measures resisted all attempts at cementation on account of the chips of clayey material produced by ordinary boring augers, which would lodge in the fissures and crevices and effectually block them, even against pressures of as high as 142 pounds per square inch.

The adhesion of the material cut by these augers in the argillaceous marl was sufficient to bring it to the surface attached to the augers.

Each application of the augers deepened the hole about 3 feet 3 inches, and the walls of the hole were then scraped by means of reamers, which removed any clay covering or other material that had been forced into the cavities and fissures, and which would otherwise prevent the cement from penetrating into the cracks and fissures. The drill stem, which was formed of hollow steel tubes of 2½-inch internal diameter, was used for injecting the

cement. By this method between 10 and 13 feet were bored and cemented per day of 13 hours.

In order to ensure a perfect mixing of the cement and water, as well as to save in labor, mechanical mixers were adopted. These consisted of a tub in which a shaft with paddles makes about one revolution per second. The cement and water are thrown in at the top and the mixture run off to the pumps through pipes placed near the bottom of the tub, but above and connected with the valves of the pump. The general arrangement is shown in Fig. 2. The pumps are of the Weise and Monski compound type, with flywheel and two plungers, run at 75 revolutions per minute, and delivering a flow of 335 cubic feet per hour.

In order to avoid the corrosive action of the cement the ordinary valves were replaced by steel balls 3½ inches in diameter, weighing 10 pounds apiece. With this precaution it was possible to pump from 200,000 pounds to 250,000 pounds of cement without difficulty, otherwise the valves had to be changed after every 6,000 to 8,000 pounds of cement had been pumped.

From the bottom of the casing pipe, embedded in concrete, the strata were either injected with cement in successive stages of 16 feet 5 inches, at pressures varying according to the ground, or in some cases a bore hole was driven to its full depth so as to cement around the entire length of the hole in one process.

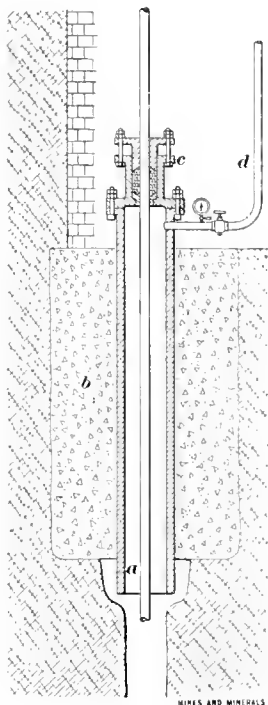

FIG. 1

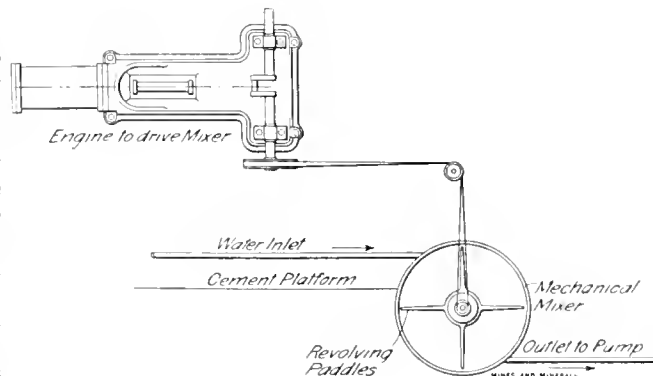

FIG. 2

If the injection was being done by stages, after the required depth has been bored and the hole thoroughly washed in each case before injection, a cup-shaped plug was lowered to the bottom of the hole for the purpose of preventing any cement from sinking downwards that would naturally solidify and hinder the boring of the next stage. This plug was raised after each injection and not lowered until the next injection was required.

The injection pipe should be of comparatively small section, so as to compel a rapid circulation of the liquid cement in the pipe and round the bottom of the hole, whereby any tendency of the mortar to separate is overcome.

If at the surface the pipe is connected to the pump by means of a strong rubber hose that permits a certain amount of vibratory and sliding motion to the pipe, the accumulation of the cement in the pipe that would tend to choke it is to some extent prevented.

After the injection pipe has been lowered almost to the bottom of the hole the head gear or "plug" is bolted to it. Clear water is then put through the pump, the cock on the return pipe at the top of the casing under the plug being left open.

After a thorough washing of the hole and when the return water is clear, the cock is shut and the pump worked to its full capacity, in order to drive any debris remaining as far back as possible into the fissures and cavities to be cemented.

The water pressure is continued about a half hour, and then, without changing any conditions, cement is injected gradually to form about 5 per cent. of the weight of mixture.

After about 1 hour the quantity of cement is raised to 10 per cent. if no increase of pressure has been noticed in the hole. As the cement deposits in the fissures of the rock the pressure recorded by the gauge increases.

Finally, as the fissures become more thoroughly plugged with cement, in order to avoid too great a pressure and the stopping of the pump, the cock on the

return is gradually opened and any excess of cement carried back to the mixer.

Fig. 3 shows the circuit for the cement, leaving out the pump, which under some conditions is not required, since, if the mixer is sufficiently elevated, this comparative position will supply the pressure necessary to inject the cement.

The operation is finished when it becomes necessary to keep the return pipe entirely open to maintain the working of the pumps.

The pump and pipes are then cleaned by running through them a current of water, after which the pressure pipe is withdrawn and the hole left from 8 to 10 hours to allow the cement to set.

No cement is left in the hole after the washing; all the cement used has found its way into the surrounding ground.

When it is noticed that the pressure in the injection pipe has suddenly dropped (this being due to the dislodgment of a plug in a partially solidified cemented fissure or to the opening of a channel connecting with the surface), mortar containing 30 to 33 per cent. of cement is injected under low pressure. Another way of meeting this trouble is to line the hole down to some solid stratum with a casing pipe smaller than the upper one. All six bore holes were injected in the same manner, and, after they had been carried to a depth of from 10 to 15 meters*, sinking operations were started.

The work of boring was not actually done by the company, but by an outside firm of contractors, Churtiez de la Basse.

The following prices were paid:

* 1 meter = 3.28 feet.

1. For the first 40 meters of bore holes, 25 francs per meter* or about \$1.47 per foot; for the rest, 30 francs per meter, provided that a minimum of 360 meters was sunk in all.

2. A charge of 150 francs was made for the "head" or plug in the top of each bore hole; that is to say, for placing the tubes and accessories in position, which prevented the cement sludge from overflowing at the top of the hole.

3. A charge of 9 francs per meter of bore hole was made for the necessary steam to drive the machinery.

The total cost was as follows for the six bore holes required for cementing the ground around the shaft, which was sunk with a diameter of 15 feet 6 inches.

The six bore holes cost:

	Francs
(1) 240 meters, at 25 francs per meter.....	6,000
120 meters, at 30 francs per meter.....	3,600
(2) Tubes and accessories at the surface of the six bore holes, at 150 francs each.....	900
(3) Cost of steam for all purposes, 363 meters at 9 francs per meter.....	3,240
(4) The cement injection cost.....	1,584
(5) Manual labor employed by company.....	1,790
(6) Explosives, 60 kilograms† at 12 francs per kilogram.....	720
(7) Cement consumed.....	12,758
(8) The Weisse and Monski pumps.....	2,450
(9) Repairs, etc.....	60
(10) Sundry necessities, oil, rubber, tubes, etc.....	383
(11) Necessary materials for the head of each bore hole.....	500
(12) The cost of labor to move the machinery.....	175
	34,160
	\$6,592.88 = £1,364 =

To give some idea of the amount of cement injected and the pressure required in different cases, No. 2 bore hole is taken as an example:

Depth	Rock	Cement Absorbed in Pounds	Cement Returned Pounds	Pressure Per Square Inch Pounds
Fl. In.				
16 0	Earth.....			
32 0	Crumbly chalk.....	27,700	700	71.0
49 0	Crumbly chalk.....	46,300	2,000	14.2—142
65 0	Crumbly chalk.....	48,200	3,000	42.6—183
81 0	Chalk and flints.....	42,900	3,000	48.4—128
97 6	Chalk and flints.....	33,200	4,400	42.6—170
114 0	Chalk and flints.....	23,600	4,000	42.6—7.1
130 0	Chalk and flints.....	33,900	6,000	42.6—185
146 0	Chalk and flints.....	7,400		85.2—121
260 0	Gray fuller's earth....			
	Total for 146 feet .	263,200	23,100	

Consumption of Cement.—The cement used in the six different holes, 705,200 pounds; the cement brought to the surface in washing, 110,400 pounds; the cement absorbed in the holes and therefore utilized, 598,800 pounds.

During the actual operation of injection the percentage of the total consumption of cement used effectively in the six different holes was 84 per cent., but of course the remaining 16 per cent. were subsequently utilized by being pumped back, and subsequently injected into other holes.



Bauxite and Aluminum Production

As stated in a bulletin of the United States Geological Survey, the 1910 output of bauxite in the United States was 148,932 long tons, valued at \$716,258. The average price at the mines has been: 1908, \$5.06; 1909, \$5.26; 1910, \$4.81. Bauxite is principally used in the production of metallic aluminum, and in the manufacture of the artificial abrasive, alundum, at Niagara Falls. This abrasive is made in the electric furnace by fusing calcined bauxite. Experiments are also being made in admixing bauxite with other materials for making refractory brick, which for linings far exceeds the life of silica or fireclay bricks. In a recent report of the United States Geological Survey it is stated that the world's production of bauxite in 1909 totaled 270,581 tons, valued at \$949,924, of which the American share was 128,099 tons, worth \$251,188.

* 1 franc = \$.193.
† Kilogram = 2.2 pounds.

Genesis of Silver Deposits

Comparisons of Geological Features and Conclusions in Regard to The Origin of Various American Deposits

By W. G. Mattson

In this article, which is the last of a series on the features common to the world's greatest silver districts, the genesis of the silver deposits is treated. The author has previously shown that 90 per cent. of famous silver deposits are in veins. Faulting, fissuring, and ore deposition, furthermore, are closely associated factors; consequently it is not surprising that a study of ore genesis reveals many marked points of similarity in the origin of the various silver lodes.

The Origin of the Comstock Lode.—Becker, in his treatise on the Comstock Lode, Nev., proposes the lateral secretion theory as an explanation for the Comstock ores. After the formation of the main fissure of this region, floods of heated waters, containing carbonic and sulphuric acids and possibly other active reagents in solution, rose from great depths. These waters followed the fissure as far as possible but were largely deflected into the fractured mass of the hanging wall, causing widespread decomposition. In this process, silica and metallic salts were set free from the mineral constituents of the rock, were carried into the open spaces of the fissure and, on relief of the great pressure and diminution of the temperature to which they had been subjected, deposited simultaneously their silicious and mineral contents. The precious metal constituents were derived from the augite of the diabase which forms the hanging wall, as upon assay the fresh diabase shows noticeable quantities of gold and silver, sufficient to account for the Comstock ores, while the decomposed diabase shows little value in these constituents.

Thus, the origin of the lode began with deep-seated solutions which rose from considerable depth under tremendous heat and pressure, and eventually permeating the country rock, dissolved out the silica and metallic constituents of the diabase, depositing the same in the open fissure on relief of temperature and pressure. This theory of Becker seems plausible since: It agrees with all observed facts; it accounts for the indefinite character and widespread decomposition of the hanging wall; the intense heat of the Comstock mines at depths of two to three thousand feet is conclusive evidence of the presence of solfataras and thermal springs, carrying the necessary chemical reagents; the volcanic character of the country and the presence of solfataras and correlative facts.*

Tonopah Silver Deposit.—This is closely analogous to the Comstock, in that there is a noticeable increase of heat with depth. During most of the Tertiary period, Tonopah, Nev., was the seat of tremendous volcanic activity. Each eruption was followed by solfataric and fumarolic action, succeeded by hot springs, resulting in a thorough alteration of the rocks in various parts of the district. During the period of subsiding volcanism, the water and other vapors, given off by the congealing lava below, carried with them metallic and silicious constituents which were separated and concentrated from the magma and deposited in the fractures produced by the volcanic forces. The nature of the metallic constituents found in these fractures depends, in all probability, upon the particular magma from whence the emanations proceeded. This magma, in the case of the Tonopah veins, was the earlier andesite, the formation in which the rich veins are found.

Origin of the Pachuca Silver Deposits.—Ascending solutions, which gathered their metallic constituents from deep-seated magmas, are conceded generally to be the origin of the Pachuca, Mexico, ores. The eruptions of andesite in this region took place through large

fissures, and during these eruptions other openings, parallel and adjacent to the fissures, were produced. Fumarolic and solfataric action with the circulation of silicious streams of hot waters followed, transporting from below, the sulphides, chlorides, and metallic salts present in the magmas. Thus, on diminution of temperature and pressure, the constituents of these waters were deposited in the open fissures. The similarity in the mineralization of the Pachuca district with that of the Comstock is revealed in the indefinite character of the wall rock in the Mexican camp. The veins of the Pachuca ore bodies are found in pyroxene andesite.

Guanajuato Silver Deposits.—The origin of the Guanajuato, Mexico, ore deposits is also accounted for by ascending solutions which gathered their constituents from the rocks traversed in their upward course. Faulting and fissuring, preceding ore deposition, provided an outlet for the underground circulating waters, which under great temperature and pressure, took into solution, in order of their solubility, whatever metals and minerals they encountered. Subsequently, these solutions gradually cooled and the pressure decreased, thus lessening the solvent power of the water. The more insoluble burdens were, therefore, deposited in place of the easily soluble materials they came in contact with, and thus replacement occurred. The first solutions were highly alkaline and, therefore, showed a tendency to attack the more silicious rocks, thus accounting for the presence of the rich ore deposits in rhyolite. As in the previous instances, the walls of the veins in portions of the district are more or less completely destroyed or decomposed by the ore-bearing solutions.

Aspen Silver Deposits.—While ascending solutions are the origin of the Aspen, Colo., ores, the source of the water was from above. These surface waters, working downward, came in contact with the igneous mass which underlaid this area, were thus subjected to great heat and pressure and subsequently dissolved some of the surrounding rock materials including the precious metals. These heated waters were then forced upward, and deposited their contents mainly at the intersections of fault fissures where they met other solutions containing precipitating agents. The precious metals were derived from the dark colored silicates of the igneous mass such as hornblende, biotite, and olivene.

Park City Silver Deposits.—At Park City, Utah, faulting and fissuring preceded all chemical activity. The igneous intrusions and slowly cooling laccolitic masses gave up their heat to the mineral-bearing solutions, thus subjecting them to high temperature and pressure, which in turn stimulated their circulation. These solutions, on working their way to the surface, were slowly cooled simultaneously with decrease in pressure, deposition of their metallic contents resulting. Other factors, such as the mingling of solutions of different kinds, the nature of the gangue filling the fissures, the composition of the wall rock, and, in the case of the bedded deposits, the union or intersection of different verticals in a horizon favorable to metasomatic replacement, had considerable effect on precipitation of the minerals. The ore-bearing solution was alkaline and probably derived its metallic contents from the dark silicates of the igneous masses.

Cobalt Silver Deposits.—Diabase magma is the source of the silver minerals of the Cobalt, Canada, district. The metals were deposited from highly heated and impure waters which circulated through the cracks and fissures of the formations, following the post-middle Huronian diabase eruption, leaching the diabase of its metals and depositing them in the fissures when conditions were favorable for precipitation.

Coeur d'Alene Silver Deposits.—The great vertical range of the ore deposits of the Coeur d'Alene, Idaho, district, the shape of the pay shoots, the lack of dependence of deposition on details of the present topography, indicate that the source of the ores is deep seated and that they were precipitated from ascending solutions. These solutions, and perhaps gases, came undoubtedly from an underlying monzonitic magma and were under high temperature and pressure. They first effected the metamorphism of the contact zone, depositing ores rich in sphalerite and pyrrhotite. Later the important galena-siderite minerals were precipitated.

* Although the writer has quoted Becker as authority on the geology of the Comstock Lode, it must be remembered that Becker made his investigation at a time when the study of ore genesis was in its infancy and Sandberger's theory of lateral secretion was almost universally accepted as the origin of most ore deposits. Since then the investigations of Hague and Iddings have shown that the Comstock is a fault fissure in one kind of rock and not a contact fissure between diorite and diabase, as stated by Becker. The theory of ore deposits has also made rapid advancement and in the light of present deduction on this subject, it is possible that, with the same evidence, some other theory of ore genesis might be applied to the Comstock Lode.

Leadville Silver Deposits.—While many theories have been propounded to account for the origin of the famous Leadville, Colo., deposits, not one has overcome all objections sufficiently to meet with general approval. According to Emmons,* plenty of evidence is at hand to indicate that:

- The ores were deposited from aqueous solutions;
- The ores were deposited in the original form of sulphides;

The process of ore deposition was a metasomatic interchange between the materials brought in by the solutions and those forming the country rock:

The ores were deposited after the porphyry sheets were intruded and consolidated but before the dynamic movements which produced the great and numerous faults of this region;

The ore solutions did not come directly from below, but were probably ascending in nature;

The mineral-bearing solutions derived their contents mainly from the porphyry bodies above the blue limestone.

Thus, Emmons distinguishes from an ultimate and immediate source of the ore, and believes the latter to be from aqueous solutions which entered the blue limestone along the contact of the porphyry sheets, obtaining their precious metal content from the igneous rocks above. While the ultimate source is believed to be ascending solutions, sufficient data have never been presented to firmly establish such an hypothesis.

Broken Hill Silver-Lead-Zinc Deposits.—The origin of the ore bodies of the Broken Hill, Australia, field has been for years, and still is, a matter of controversy. Jaquet and Pittman believe the ore body to be a saddle lode, Jaquet claiming lateral secretion as the process of ore deposition. Donald Clark, on the other hand, considers the lode as formed by materials brought up from below and filling cavities which were produced during the uplifting of the range.

The metals of the Broken Hill Consols lode were brought up in solution from depths and, according to George Smith, a mining engineer of that region, were deposited by a continual succession of electro-magnetic currents passing through the cross-veins.

COMPARISONS AND CONCLUSIONS

The following table summarizes briefly the genesis of the described silver deposits:

TABLE I. GENESIS OF VARIOUS SILVER DEPOSITS

District	Origin of Ore Bodies	Source of Ore
Comstock.....	Ascending solutions—lateral secretion	Diabase
Tonopah.....	Ascending solutions	Andesite magma
Pachuca.....	Ascending solutions	Deep-seated magmas
Guanajuato.....	Ascending solutions	Igneous magmas
Aspen.....	Ascending solutions	Biotite, Hornblende, Olivine
Park City.....	Ascending solutions	Dark colored silicates of eruptive rocks
Cobalt.....	Ascending solutions (?)	Diabase
Coeur d'Alene.....	Ascending solutions	Monzonitic magma
Leadville.....	Descending and ascending (?) solutions	Porphyry
Broken Hill.....	Ascending solutions	?

(?) Controversy still existing in these cases.

Thus an investigation of ore genesis of the world's greatest silver districts reveals the following points of similarity:

1. Ascending solutions have been either the ultimate or immediate origin of the ores in practically every case.
2. With one exception, fissuring and fracturing has preceded ore deposition and mineralization.
3. Igneous rocks are inseparably connected with the ore-bearing solutions, the latter deriving their precious-metal content from the former in every instance.
4. The prevalent tendency of the ascending solutions is to decompose the country rock and give an indefinite character to the vein walls.
5. Fissuring and ascending mineral-bearing solutions seem inseparable phenomena, the latter invariably succeeding the former.

* S. F. Emmons—U. S. G. S. Monograph XII, Bulletin 320.

6. Precipitation of the metals and minerals from solution is accomplished invariably by lowering of temperature and pressure. Other factors having an important bearing on precipitation are the character of the wall rock, the character of the gangue and the mingling of solutions of different compositions.

7. The mineral bearers in general possess a definite method of rock selection, depending upon the nature of the solution (whether acid or alkaline).

THEORY OF METALLOGRAPHIC AND PETROGRAPHIC PROVINCES AS APPLIED TO THE WORLD'S GREATEST SILVER DISTRICT

Investigations by various geologists, especially Spurr in the United States and Alaska, and Ordonez in Mexico, have led to the conclusion that the entire western portion of the western hemisphere, beginning with Alaska and proceeding southward past Sitka, through Washington, Oregon, the Sierra Nevadas, Nevada, Mexico, the Andes, Central and South America, is a zone which might be termed a petrographic province; in other words, it is a zone underlain by a single body of molten magma, which has supplied, at different periods, lavas of similar composition to all parts of the overlying surface. The general sequence of these lavas, as given by Spurr, is

1. Rhyolite (Eocene);
2. Andesite (Miocene);
3. Rhyolite with occasional basalt (Miocene-Pliocene);
4. Andesite (late Pliocene-early Pleistocene);
5. Basalts and occasional rhyolites (Pleistocene).

The great majority of the mining districts in this area are, furthermore, characterized by minerals of like composition, which leads to the development of the theory of metallographic provinces which, in many instances, are closely allied with the great petrographic area.

There is little doubt but what the districts of Comstock, Tonopah, Pachuca, and Guanajuato belong to the same petrographic province. The eruptive rocks covering these areas are practically identical, being composed of Tertiary volcanics, chiefly andesites, the geologic succession of rocks is very similar and the veins are found in andesite magmas of Miocene age. Moreover, the general sequence of lavas is practically the same as that outlined above.

It has been shown in the discussion of the mineralogical features in February, 1912, MINES AND MINERALS, that these districts were practically identical in the kind of ores, the occurrence of the ores and in the physical conditions of the various ore zones. Hence these districts are in a metallographic province which coincides exactly with the petrographic area.

Leadville, Aspen, and Park City districts, possessing identity in age, and order of succession of the strata, may be said to exist in a single petrographic province, which, however, is somewhat different from that described above. The formations here are essentially sedimentary, but that they are underlain by an enormous eruptive mass is evident from the intrusive rocks found in these beds. Furthermore, the similarity in the kind of intrusives (white porphyry) strengthens the evidence that the igneous mass underlying each particular district in question is part of a single body of magma.

Leadville, Aspen, and Park City, also, belong to the same metallographic province, the similarity of ores, the kinds of minerals found and the conditions of the mineralized zones are almost identical, while marked similarity is shown in other features such as the ore occurrence and the effect of the igneous intrusives.

All the silver districts, classified as those in which the formations were essentially sedimentary, may be placed in a single metallographic province, but in this case the latter only partly coincides with the petrographic province of Leadville, Aspen, and Park City, since the formations of Cobalt and Broken Hill vary too much in essential details to be classed in the same petrographic area with them, and are also too remote from each other.

It is clearly seen from the foregoing that a sharp line of demarcation may be drawn in the classification of the described silver districts into those districts where the deposits are found chiefly in eruptive rocks and into those districts where the rock formations are essentially sedimentary, and that the deposits included in each

grouping possess marked similarity in areal geology, in vein formation, mineralogy, and ore genesis. The groups themselves are drawn close together by certain features common practically to every district. Thus, an analysis of the subject has revealed:

1. That all the silver deposits are intimately and inseparably connected with eruptive rocks from which the precious metal constituents have been derived.

2. That hot ascending solutions under tremendous pressure have been generally the vehicle of ore deposition, precipitation of the minerals and metals usually resulting from the lowering of temperature and pressure.

3. That faulting, fissuring, or fracturing, combined with igneous intrusion has generally preceded ore deposition.

4. That practically all veins (90 per cent.) are characterized in the main details by fissure formations.

5. That decomposition or alteration of the country rock in the vicinity of the veins has resulted usually from the hot ascending mineralizers or ore carriers.

6. That the wall rock has had an immense influence on deposition, producing what might be termed "selective precipitation."

7. That fissuring and hot ascending mineral-bearing solutions seem inseparable phenomena.

8. Finally, the many marked features of similarity permit the application of the theory of petrographic and metallographic provinces to each group.

來 來

Catalogs Received

ALLIS-CHALMERS Co., Milwaukee, Wis., Bulletin No. 1801, The Isbell Vanner, 20 pages.

ATLAS ENGINE WORKS, Indianapolis, Ind., Bulletin No. 201, Atlas Crude-Oil Engines (Diesel Type), 36 pages.

THE BRISTOL Co., Waterbury, Conn., Bulletin No. 161, Wm. H. Bristol, Electric Pyrometer, 16 pages; Bulletin No. 162, Bristol's Recording Gauges, 16 pages.

BEST MFG. Co., Pittsburg, Pa., Catalog No. 103, Piping Materials for Steam, Air, Hydraulic, High-Pressure Piping Systems, 395 pages.

THE FERRO MACHINE AND FOUNDRY Co., Cleveland, Ohio, Ferro Engines, A Practical Treatise, 48 pages.

GENERAL ELECTRIC Co., Schenectady, N. Y., Bulletin No. 4893, General Electric Automatic Time Switch, Types T-5 and T-6, for Alternating- and Direct-Current Circuits, 4 pages; Bulletin No. 4896, High Voltage Core Type Transformers, 9 pages; Bulletin No. 4903, Isolated and Small Plant Direct-Current Switchboards, 16 pages; Bulletin No. 4904, Small Plant Alternating-Current Switchboards, 1,150 and 2,300 volts, 60 to 125 cycles, 8 pages; Bulletin No. 4905, Small Plant Alternating-Current Switchboards, With or Without Separate Feeders, 16 pages.

HOWELLS MINING DRILL Co., Plymouth, Pa., Catalog No. 28, Howells Mining Drills Operated by Electricity, Air, and Hand Power, 111 pages.

THE INDUSTRIAL INSTRUMENT Co., Foxboro, Mass., Bulletin No. 58, Thermometers and Thermographs for Indicating and Recording Temperature, 24 pages; Bulletin No. 59, Recording Liquid-Level Gauges, 12 pages.

INGERSOLL-RAND Co., 11 Broadway, New York, N. Y., "Arc Valve" Tappet Rock Drills, 16 pages.

KEYSTONE DRILLER Co., Beaver Falls, Pa., Catalog No. 4, Keystone Cable Drills for Drilling Blast Holes, 36 pages.

THE SCHAEFFER & BUDENBERG MFG. Co., Brooklyn, N. Y., Catalog No. 27, Thermometers, 1911, 72 pages.

THE UNION IRON WORKS Co., San Francisco, Cal., Catalog No. 5, Evans Hydraulic Elevators and Hydraulic Mining Machinery, 23 pages.

ZIERMOKE REGULATOR Co., Johnsonburg, Pa., Perfection in Pressure Controlling and Regulating Valves, Styles A, B, D, G, and K.

GENERAL FIRE EXTINGUISHER Co., Providence, R. I., "Grinnell" Automatic Sprinkler Bulletin, 26 pages.

Gold and Silver Output, 1911

The following preliminary estimates furnished by the United States Geological Survey, will not be greatly changed:

In addition to the yields of gold from placers and silicious and pyritic ores, notable contributions to the gold production were made from copper, lead, and mixed ores. Silver mining as an industry is of relatively small importance in the United States, the domestic production depending on the output of gold, silver-gold, copper, and lead ores. Aside from the milling of the silver-gold ores of Tonopah, Nev., the bulk of the silver production was derived from smelting copper, lead, mixed ores, and concentrates. Increased copper production in Alaska added to the silver output of that territory. The average price of silver in 1911 was 53 cents per ounce, against 54 in 1910.

	Gold, 1911	Silver, 1911
Arizona	\$2,954,790	\$876,935
Colorado	\$19,153,860	\$4,142,017
California	\$20,310,987	\$1,500,035
New Mexico	\$639,897	\$628,284
South Dakota	\$7,430,367	\$113,403
Idaho	\$1,169,261	\$4,129,291
Alaska	\$17,150,000	\$220,000
Montana	\$3,169,840	\$6,114,228
Utah	\$4,709,747	\$6,973,798
Nevada	\$18,968,578	\$5,858,364
Oregon	\$599,235	\$38,014
Washington	\$504,537	\$78,209

Preliminary figures of the Director of the Mint indicate a total domestic gold output of \$96,233,528 in 1911, against \$96,269,100 in 1910.

According to estimates made by the Bureau of Statistics the imports in 1911 comprised gold valued at \$11,150,000 in foreign ore, \$29,300,000 in foreign bullion, \$5,750,000 in United States coin, and \$10,050,000 in foreign coin—a total of \$56,250,000. The gold exported in 1911 was valued at \$500,000 in domestic ore, \$8,050,000 in domestic bullion, \$30,000,000 in United States coin, and \$2,250,000 in foreign coin—a total of \$40,800,000. The excess of imports over exports was about \$15,500,000, indicating a marked change from the conditions in 1910, when the excess of imports over exports was \$447,696, and also from those in 1909, when the excess of exports was \$88,793,855.

The gold imported in 1911 was mainly in the form of ore and bullion, and came chiefly from Mexico, although considerable gold is received from Canada every year and smaller amounts from the Central and South American countries, and in 1911 a large quantity of gold was imported from Japan. The exports consisted largely of gold coin and went chiefly to Canada, although smaller shipments were also made to France, South America, the West Indies, and Japan.

Preliminary figures compiled by the Director of the Mint indicate a total domestic production of silver in 1911 as 57,796,117 fine ounces, valued at \$31,787,866. The production in 1910 was 57,137,900 fine ounces of silver, valued at \$30,854,500.

According to estimates made by the Bureau of Statistics the imports of silver in 1911 were valued at \$27,450,000 in foreign ore, \$12,850,000 in foreign bullion, \$2,150,000 in United States coin, and \$1,350,000 in foreign coin—a total of \$43,800,000. The exports of silver during the same year were valued at \$135,000 in domestic ore, \$65,000 in foreign ore, \$59,000,000 in domestic bullion, \$4,750,000 in foreign bullion, \$100,000 in United States coin, and \$600,000 in foreign coin—a total of \$64,650,000, or \$20,850,000 in excess of the value of the imports.

In 1910 the value of the excess of exports over imports of silver was \$11,482,805; in 1909 it was \$11,404,607, and in 1908 it was \$9,613,541. Previous to 1908 it had not been below \$15,000,000 for several years.

The imports of silver in 1911 were, as usual, chiefly in ore and bullion and came mainly from Mexico and Canada. The exports were almost wholly in ore and bullion and went, as usual, chiefly to the United Kingdom and in smaller amounts to Hongkong and France.

Notes on Hydraulic Placer Mining

Examining the Ground—Water Supply—Construction of Dams, Flumes, Sluices, Pipe Lines, etc.

This paper was presented to the Institute of Mining and Metallurgy by N. A. Loggin, under the title, "Notes On Placer Mining, With Special Reference to Hydraulic Sluicing."

The mining of gold by the hydraulic process is in theory a simple operation. It consists in conveying water through pipes, under a pressure obtained either by gravity or pumping, to a point whence it can be delivered through a reducing nozzle against the bank of alluvial requiring to be worked. The gravel is undermined by this means, and the loose stuff is washed into a specially constructed wooden sluice box, provided with spaces in its floor into which the gold drops by virtue of its greater specific gravity, whilst the waste debris passes down the sluice to a dump. In practice, this apparently simple operation involves difficulties which can only be overcome by experience, and it is with a view to affording useful hints to those who have not had that experience that these notes are submitted.

At the outset, the value of the placer mine must be established, and sufficient gold must be found per cubic yard to make it a profitable proposition. In reporting on a mine of this description, the gravel is usually estimated by the cubic yard, and it is usually considered that there are about 120 pans to the cubic yard. A cubic yard of gravel generally weighs about 1½ tons as it comes from the

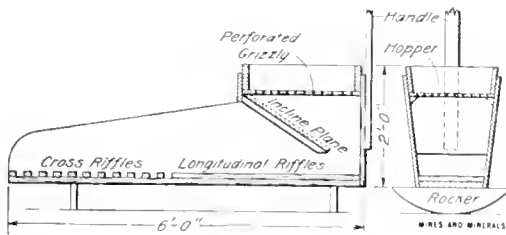

FIG. 1. THE ROCKER

in values, is to mark off the ground in areas of about 100 feet square, and sink holes at each corner of the different sections.

The rocker is illustrated in Fig. 1, and is made of boards; it is usually about 1 foot wide and 2 feet deep, and from 3 to 6 feet long. The interior is provided with a hopper, having a perforated iron tray at its bottom to separate out coarse material. Below this screen is a wooden frame with canvas nailed on it, sloping toward the back of the rocker, over which the particles which pass the screen travel. On the bottom there are series of riffles, some lengthwise and some across, formed by strips of wood about 1 inch square, which are detachable for cleaning up. The operator holds the handle at the back of the rocker whilst he or some other man places the gravel into the hopper. A small stream of water is fed in at the same time through a pipe or trough, and the rocking motion is maintained while there is any material in the rocker. The coarser material left in the hopper is removed from time to time, but the finer particles pass through and over the sloping plane on to the riffles, which arrest the greater part of the black sand and the gold, allowing the gravel to pass on and out to the dump. When a sufficient quantity has been washed the riffles are taken out and foreign substances removed, the concentrates being panned.

The sluice box consists merely of three boards nailed together so as to be water-tight, to make a trough about 12 feet long by 1 foot wide and 1 foot deep, set on a grade of 6 inches in 12 feet or more, according to the requirements of the operator. It has also a series of riffles, sometimes lengthwise and sometimes across. A series of these sluice boxes is often used, one following the other, and for this purpose they are usually made slightly tapering, so that the

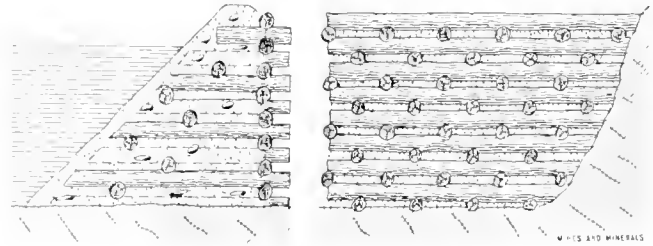

FIG. 2. MUD AND LOG DAM

bank, but of course this varies according to the quantity of water put into it.

Various methods are employed for making determinations of the value of gravel. If the property is small, the usual way is to dig shafts to bed-rock, and pan every foot or so all the way down, exercising care not to favor unduly the streaks of black sand, red gravel, or other indications met with. The fairest way of proceeding is to use a rocker or small sluice box, if there is water available, using it impartially from top to bottom of the shaft section, and keeping an accurate account of the total amount of gravel washed. When a certain amount has been through the rocker, washing may be stopped, and the residue panned, the gold being placed in small bottles after separating the magnetic iron and other elements that may be mixed with it. To do this, the residue should be placed on a piece of white paper, and a magnet passed through it to extract the black sand; after this has been done several times with care, and the magnetic particles are removed, the magnet should further be passed to and fro below the paper, to draw out the smaller particles that for any reason failed to be attracted by the magnet previously. After this operation, any further particles other than gold can be winnowed out by blowing with the mouth, and the gold is then ready to be weighed. On the average, placer gold is worth about 35 cents per grain. Having weighed the gold, the number of cubic yards of gravel that have been washed must be estimated, and the value of the ground per cubic yard can thus be found.

When there is a large area of gravel to examine, it is best to employ a mechanical appliance, such as a Keystone drill, as this will be found much cheaper and quicker than hand sinking. One of the systems of exploiting where the ground is known to be uneven

end of one will fit inside the upper end of the next below it, thus preventing the residues from going to waste. Experience shows that gold seldom travels far in a sluice box when the gravel is shoveled in by hand, most of it being found within the length of a few feet. It is found that the rocker or sluice box will give a nearer estimate of the gold that can be saved in actual practice than the pan, as there is more impartiality in the method adopted of shoveling the gravel into the hopper or box than in filling the pan with a sample.

After determining the value of the mine by one or other of the foregoing methods, the next matter for consideration is the possibility of a suitable water supply.

A good way to estimate the water in a stream is to measure the depth and width of the stream at several different places, add the figures together, and divide by the number of measurements taken; this gives the average volume of the water. Then measure off a given distance, say 300 feet, along the river bank, and after throwing several floats or pieces of wood into the stream opposite the higher mark, take the number of seconds they occupy in traveling to the other point; the average of the series, less a deduction of 25 per cent. to allow for the friction of the wetted perimeter, will give the rate of discharge of the stream in feet per second. For example, if a stream should measure 12 feet across on the average, taking it as of the usual contour of bed, it should be estimated as of 8 feet mean width; taking the depth as 3 feet, and the mean velocity to be 3 feet per second, we get 8 ft. × 3 ft. × 3 ft. per second equals 72 feet per second as the mean discharge of the stream.

It is often necessary to go many miles back from the site of the mine to find the best place for diverting the water in order to get the necessary "head" which should be at least 150 feet, and preferably

between 200 and 300 feet. An approximate estimation of the head can be obtained by means of an aneroid barometer, calculating from the proposed intake to the upper part of the mine, if time does not allow of more exact measurement with a level. The best way is to take a point sufficiently high above the mine to give the necessary "head" and then run a line with a level rising about 1 foot per 500 feet, until the stream from which the water is to be obtained is reached, when the length of ditch required can be ascertained.

A point that requires particular attention is the place at which the ditch takes its water from the supplying stream. For this a piece of rocky ground should be selected, if possible, and the intake should be lined with hydraulic cement. To insure a proper supply of water at all times it is customary to block the stream with a small dam immediately below the intake. The dam is generally built of logs and rocks, and a good method is to employ the system shown in Fig. 2, consisting of a set of ordinary log cribbing built across the stream with logs laid longitudinally to the stream at intervals of about 5 feet, these being further braced at the other end with other transverse logs. The spaces between these logs are then filled with rock and mud. Wings of logs should extend either side well on to the banks of the stream to guide the stream over the dam, which should have a boarded top inclined at a grade of 1 inch per foot to allow the overflow to get off quickly.

Ditches and waterways require great care and good judgment in their construction; a badly made ditch will cause untold trouble. The usual gradient through average soil is from 10 to 12 feet per mile, which will ensure a free run to the water without causing undue erosion or caving of the banks. The term "ditch" is used

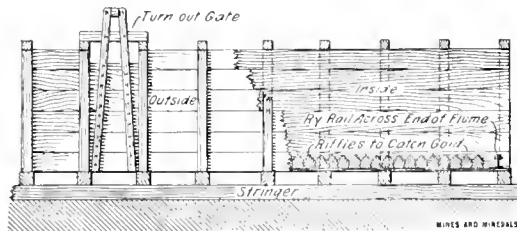

FIG. 3. SECTION OF FLUME

The best form of ditch is one in which the width is about one and three-quarters the height of the sides; these proportions seem to produce the least friction and to be most satisfactory in every way.

As the depth of water in a flume decreases, the friction augments in ratio to the volume of water carried, so that the deeper the water relatively to its volume the faster the flow. Generally speaking, a mean depth of water of from 18 to 20 inches and a grade of 10 feet 6 inches to the mile, represent proved good practice, with the width in proportion as above mentioned. Most ditches are made with their sides too steep, causing a tendency to cave or filter in; the natural slope of earth is about 45 degrees, but the author favors a slope of about 1 in 4 at the top, curving gradually toward the bottom, so as to approximate to the semicircular cross-section already alluded to as the best form.

When the banks have to be raised above ground level, the outside curve should always have extra thickness, for, if there is vegetation on it, the earth will be porous, and the seeping of the water will before long take the bank with it, causing loss of time and labor, and possibly heavy bills for damages. It must be remembered always that without water the placer property is of no value as a mine, and that if the ditch breaks the whole of the operation must perforce stop. For this reason it is of vital importance that all ditches should be properly supervised by a man well qualified for the job, as one bad break will sometimes mean a greater extra expenditure than all the season's wages of the men under normal working conditions.

The velocity of the water should not be more than 3 feet per second, which allows the sediment carried in suspension from the

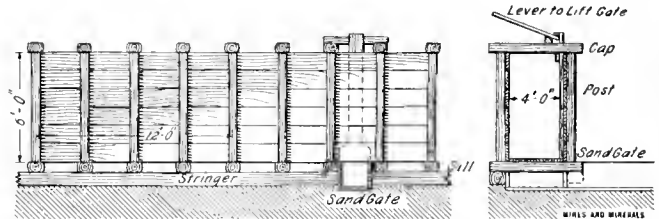

FIG. 4. FLUME WITH SAND GATE

in this connection to indicate a channel cut through rock or soil. Ditches for hydraulic mines are often brought through apparently impossible country. Sometimes loose gravel or "slide rock," which will not hold water, is encountered, and in that case the sides and bottom must be puddled with a mixture of clay and gravel pounded with a pole until thoroughly mixed. This forms a sort of cement which is impervious to water if properly made. In some cases, however, this process cannot be adopted, for instance, in "slide rock," where there is no soil to speak of, this part will have to be flumed, and it is quite common to have numerous sections of flume along a waterway, sometimes to the extent of half the distance or more, on account of the porous ground encountered. It is better, however, to use as much "ditch" as possible, for ditches are found to improve with age, whilst flumes decay.

In joining a length of ditch to a section of flume, care should be taken at the junction to make the flume about 2 inches lower than the ditch, for the reason that the ditch, no matter how well it is built, will cave to a certain extent, and the flume will tend, in this event, to draw off the ditch. In the same way, the lower end of the flume should be left about 2 inches high to facilitate drawing off, as the ditch will tend to fill up at that point.

Ditches should not be built with sharp corners, but should be well rounded in section. To make them square is a waste of time and labor, as they will in time assume a rounded section, however shaped originally. A ditch should be made as straight as possible, even at a slight extra cost: sharp turns obstruct the flow of the water, and, worse still, they have a tendency to produce caves, which are dangerous, to say the least of them. Where sharp bends are unavoidable, it is good practice to "rip rap" or build stone into the outside bend of the bank, to prevent it from being washed away; this practice also strengthens the bank generally.

stream to precipitate, and to seal any leaks that may exist. When water is running at too great a speed a ditch is seldom tight.

The kind of the ground through which the ditch is dug has much to do in deciding the form of construction and the velocity of the water, and as a ditch line usually has to encounter almost every kind of condition in its course, due allowance must be made for these changes. In fact, it is difficult to apply any set rule, as what may be correct practice in one part of the course will be quite incorrect elsewhere.

In planing the ditch, it is always better to provide for more water to come through than is actually required; a margin is required to meet the incidence of dry seasons, or the decision to work on a larger scale than was at first anticipated. An engineer planned a ditch and had it dug, on the basis of a flow of 20 feet per second. At the discharge end of the system the amount coming through was not more than 2 feet per second, so badly was the ditch laid out. The engineer had worked according to theory and formula, instead of from practical experience, and had not made allowance for the three disturbing elements of friction, seepage, and evaporation. Evaporation is a factor always to be taken into the account; it is productive of a considerable loss, especially in dry countries.

It is common practice to build the flume part of the waterway to a steeper grade than the ditch, also of smaller area, the theory being that water can be run faster through a flume, with safety, than through a ditch; but moderation should be exercised in this, otherwise it will be found that if the water attains too high a velocity in the flume, it will tend to scour out the end of the ditch immediately following, and this washed up material will subsequently settle and cause an obstruction lower down.

Flumes with open tops, braced at the sides, are not so satisfactory as those which are capped; the sill, post, and cap method

of construction will be found to be the best, with the running board on top for the ditch watcher's accommodation. This is usually a board about 10 inches wide nailed on top of the caps, either in the middle or at one side over one post; the latter is the better system, as it enables the man to exercise better supervision.

Great care should be taken in building a flume, to see that it has a good foundation. If the sills cannot be laid on solid rock, it is better to lay stringers below them, as leaks or overflows are certain to occur from time to time, with the consequent risk of the ground being washed away from under the flume and letting it down. Stringers are merely rough poles placed lengthwise under the sills, one along each side of the flume, and they should not be less than 15 feet long. A flume leaks to some extent until the boards become swollen, and though the leak may be small, it should be watched carefully, as it will tend to wash out the bed and tip the flume, so causing worse leaks, if not total destruction of the flume. A good method of stopping leaks in the flume is to haul several loads of manure or sawdust to a point above the defective part and dump into the stream; and the same remedy will also save trouble with leaky pipes.

Some miners build their flumes of 2-inch lumber and calk the joints, but two 1-inch boards are better, as they can be laid to break joints, which makes the surface self-sealing.

It is not advisable to make too narrow a flume, but this is, of course, a matter dependent on the amount of water to be carried. For example, to convey any quantity from 30 to 50 feet per second, the flume should not be of less cross-section than 4 feet wide and

make a truss bridge over the dangerous part, leaving a clear space below. This is not such a formidable piece of work as it would seem at first glance, and it is quite feasible to build trusses 65 feet long with the round timber cut on the spot, and with only six 1-inch iron truss rods on either side. This has been done for a flume carrying 50 feet of water per second. The greater the distance between the top and bottom members of the truss—of course within the limits of reason—the less the tension on the lower member and the compression of the top member; by attention to this matter, it is often possible to use comparatively light timber.

Miners in olden times did not always have levels and surveying instruments with which to lay out the ditch line, and would use instead an ordinary carpenter's level with a square, placed on a straight piece of board. A ditch laid out in this rough-and-ready fashion, with approximate and far from uniform grades, would frequently make a sudden drop of several feet, the section at this place being lined with poles and rocks to prevent wholesale removal of the surrounding country; yet so securely were these weak places built, and so good was the general work, that cases were known of waterways in use 40 years that require very little repair work even now.

Turn-out gates are a necessity in all ditch work, and in laying a waterway care must be taken to have as many of these as possible, so that in the event of a breakage of the bank the ditch watcher will not have far to go in order to divert the flow from the channel. The places for these gates must be chosen with discretion, preferably in rocky ground, or failing that, in firm soil; and, as an additional precaution, it is desirable to form the turn-out with a length of flume to carry the water clear of the main flume. At each of these points of turn-out two gates will be required, one opening into the turn-out, and the other blocking the main flume immediately below, so that in case of a break lower down the water can be entirely diverted into the turn-out. These gates do not require to be elaborate appliances. A gate can be made from double boards placed horizontally and securely braced with cross-straps extending above the top of the flume; further cross-pieces are nailed at the upper ends of these pieces, so that a lever can be inserted and rested on a convenient fulcrum for the purpose of lifting the gate. The gate rises and falls between guides, but it will be found convenient to have an inner guide on one side only, as there is no pressure from outside, and this omission naturally reduces the friction, and consequently the labor of raising the gate. A gate of this description is shown in Fig. 3, and is all that is necessary, though some men will devise much more elaborate and expensive contrivances to serve the same purpose.

The sand gate is another important feature in connection with the intake. Streams are frequently muddy, and carry solid matter. To stop this from going down the ditch it is usual to make a screen of poles or strips of wood, which is placed across the intake at a slope of about 45 degrees. This slope causes floating wood, etc., to rise and so not block the screen, whilst the floating mud and sand pass through until they reach the sand gate at about 20 to 30 feet lower down. The design of this (Fig. 4) is generally a small cross-flume, about 2 feet deep, set below the floor of the main flume and extending at right angles for a distance of 8 feet or more. The sand drops into the cavity and is conveyed away from the ditch. The gate is arranged to open or shut according to the requirements of the moment. In addition to the sand gate provided at the intake, it will be found good practice to arrange for others at intervals along the waterway to clear the water on its course down to the mine face.

Overflows should be arranged for at intervals along the ditch, in order to deal with exceptional quantities of water in flood time. This can be contrived simply enough in conjunction with the turn-out gates as follows: Assuming that the greatest depth allowed in the ditch or flume should be 36 inches, the turn-out gate should be only 36 inches high, and any surplus of water above that depth would naturally flow to waste over the gate.

Tunnels, where they have to be driven along the line of the ditch, should never be timbered if they will stand without it, as the lining tends to check the flow of water. They should be cut

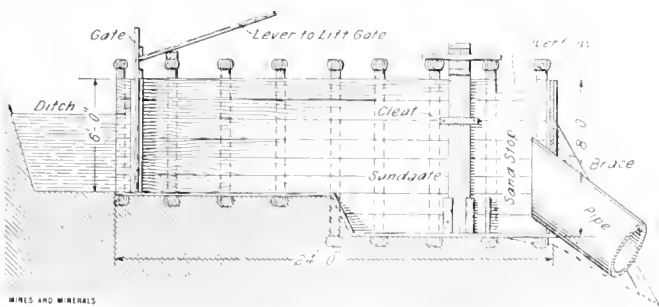

FIG. 5. PENSTOCK CONNECTING PIPE LINE WITH DITCH

4 feet high; the sills should not be less than 6 inches diameter at the small end, beveled on both sides to 4 inches, and the posts should be of not less than 4-inch diameter at the small end, hewn on one side. The caps should be of the same size as the posts, and should not be hewn. It is good practice to allow 6 inches outside the gain in the sills and the caps. The gain, which is cut into the side of the sill and into the underside of the cap, should be about 4 inches wide and 3 inches deep, and the post is cut through at the end to fit each of these respectively and fastened on with nails long enough to take a good hold. Four of these sets to each box of 12-foot lengths are generally considered to be ample. Allowing a margin for strength, the sills and caps should be 64 inches long, and the posts 54 inches. In practice, it is not necessary to carry the sides right up to the top of the posts, as it would not be probable that there would be more than 36 inches of water in the flume under any conditions.

In taking water through hilly country, it is often necessary to carry the flume across cañons by means of trestles. These can be built quite well from timber cut on the spot if such is available and there is no facility for obtaining sawn timber. In building a trestle for this purpose, it is best to put in the posts inclining together at the top at a slope of 1 in 4, and each pair at about 8 feet apart, so that each length of box has two supports. If the trestle is more than 30 feet high it is advisable to make a "double deck" as ordinary round timbers are scarcely stiff enough to be used singly of such a length, unless they are also very heavy to handle. In any case they must be well braced.

In places where there is a likelihood of frequent snow slides, or rock slides, it is good practice, if the span is not too great, to

as nearly as possible to a Gothic shape, with a more or less pointed crown, as it is found that they generally cave to that shape eventually. They should be on a slightly steeper grade than the other part of the ditch, so as to lessen the risk of being blocked by float wood or other debris.

Where there is not too abundant a supply of water, it is good practice to make a reservoir to catch the surplus water brought by the ditch when it is not required in the pipe line. It will also prove useful if at any time the ditch has to be emptied, in whole or in part, for repairs. The reservoir will usually be made by building a dam across a convenient gulch. A concrete or masonry dam, though doubtless the best, will generally be found too costly, in view of the location of most placer mines, so that it is more common to fall back upon one of timber and mud, of much the same construction as that shown in Fig. 2. It is necessary, however, to have a lumber outlet for the water, with a gate, or the dam would soon be washed away, and for this purpose a wooden tunnel is first constructed the whole width of the dam and projecting out into the reservoir, at which point the gate is placed.

The best form of gate for this position is the trap-door type, which keeps tight if well fitted, and is easier to work than the sliding variety, especially if the slides of the latter are of wood. A properly made dam, constructed in the manner described of logs with earth well placed, has been known to stand for 35 years without leaking, after it became consolidated. At first, however, constant supervision is needed to prevent leaks from developing.

The pipe line of the hydraulic plant requires a practical judgment, and great care in its design and construction. To take the water from the ditch a penstock is built. As shown in Fig. 5, it is usually built in two sections each about 12 feet long and one about 2 feet below the level of the other. The upper box is butted into the side of the ditch on a level with it, and is made about 5 feet wide and 4 feet deep, with a grade of about 2 inches in its length. At the upper end is a gate to shut off the water constructed of two thicknesses of 1-inch boards, with cross-bracings. The lower part of the penstock is built up to the same height at top as the upper portion, and closed at its lower end with timber through which the exit pipe leads. The whole is made water-tight and firmly braced, transversely by means of iron rods extending from side to side, and at the front end it is stayed against the pressure of the water by outside braces. The penstock is provided with a sand gate as shown, and with an overflow outlet. The exit pipe is inserted a distance of about 6 inches into the penstock, and has its mouth bell shaped; it should be about 3 feet in diameter at the opening, and should have its highest part sufficiently below the water level to prevent the risk of taking in air.

The pipe should gradually taper down to a diameter of 11 inches. The average placer miner experiences considerable difficulty in estimating the correct size and strength of his pipe. Two instances of this may be mentioned. In one instance, where the knowledge of hydraulics was limited, a pipe line having a uniform diameter of 10 inches to feed two 5-inch nozzles was ordered and found unable to keep one nozzle supplied at 300-foot pressure. Friction accounted for some part of this failure. In another case, a man put in a new pipe twice the size of that first installed, expecting to double his pressure. He gained a slight advantage, but not because his pressure was increased.

The point to remember in this connection is that the nozzle at the face of the mine is required to discharge a certain number of cubic feet of water per second, under a certain hydrostatic pressure, and that the nozzle must be supplied with sufficient water to yield those results. At the same time the water should not flow through the pipe line at a velocity exceeding 3 feet per second, or there will be too much friction. The size of the pipe depends upon the well known, though not always appreciated fact, that the area of a circle varies as the square of the diameter, whilst the circumference varies directly as the diameter; thus it happens that the friction in a small pipe is greater relatively to a given quantity of water passing through it than in a larger pipe.

A simple formula for finding the size of pipe required is to multiply the diameter in feet by the head in feet, and divide by the length of the pipe line in feet; then take the square root of the product and multiply it by 50, which gives the velocity in feet per second; that multiplied by the area of the pipe in square feet will give the amount of water in cubic feet discharged per second. This applies to the case where an approximate amount of water is required for a pipe of given size at the discharge end, but as the work required to be done varies, a good margin should be allowed.

A practical instance of a plant that worked in a quite satisfactory manner may be more useful than formulas. The plant was fed from a ditch at the rate of 30 cubic feet per second, into a pipe line which at the penstock end was 36 inches in diameter. In the first 100 feet the pipe tapered down to 24 inches, thence in the next 1,000 feet to 15 inches. This diameter was continued for about 3,000 feet, to the gates put in to feed various pipes. In the next few hundred feet the pipe tapered from 15 inches down to 12 and 11 inches, where it entered the "joint" which supplied two 4-inch nozzles with all the water required for efficient working. The pipe line was comparatively straight, and was constructed of No. 16 riveted steel pipe, which was quite satisfactory at first, but as the line rusted and otherwise deteriorated with age, it appeared that better practice would have been to use No. 12 gauge pipe. The hydrostatic pressure, or head, was 200 feet.

Great care should be exercised in laying a pipe line, to see that it is properly supported under every joint and frequently in between, for if the pipe is allowed to sag it will certainly leak. The pipe should be coated with a good thick layer of asphaltum inside and

out; a bath should be made for this purpose, slightly longer than the pipe to be dipped, which should be supported at each end by iron blocks to a height of about 2 feet, so that a fire can be lighted beneath it for heating the asphaltum. When the pipe has been dipped it is set aside to

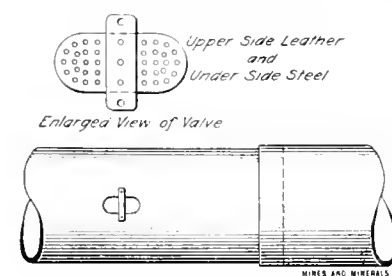

FIG. 6. PIPE LINE WITH AIR VALVE

drain. In this way, a large number can be treated in one day, and new pipe, when thus treated, can be jointed together and will remain tight without caulking, but if the pipe is old, it is a good plan to procure some cheese cloth or similar material to wrap around the ends, which can then be driven together, making a tight joint.

The line should be braced at every turn, no matter how slight the bend may be, as the outward pressure is considerable. Elbows should be avoided as much as possible, as they reduce the efficiency of the water; if it is absolutely necessary to use them, they should be put in while the diameter of the pipe remains large, as the friction will be less than in a smaller diameter of pipe. Elbows require a large amount of bracing in order to keep them in place, and in addition they should be loaded down with earth and rock to the weight of several tons, otherwise they will rise. The same precautions with regard to bracing apply to the tapers or reducing joints, where the increased pressure exercises a tremendous force tending to push them apart, and these also should be loaded down, as they have an inclination to rise.

In laying a pipe line, care must be taken to put a number of air valves into the pipes, especially if the line follows uneven ground, so that when the water supply drops at any time air can be sucked in to take its place; otherwise there will be danger of the pipes collapsing under the atmospheric pressure. These valves, which should preferably be of the "butterfly" type, can be made quite easily, and on the spot if necessary, nothing being required except some sole leather and cuttings from a steel pipe. A hole is cut in the pipe, as shown in Fig. 6, of an oval shape and about 4 inches long by 2 inches wide. A piece of leather is cut to the same shape but about an inch larger in each dimension, and two pieces of steel are shaped to the leather, leaving a space of about 1 inch between

them. The steel and leather are then riveted together, as shown in the enlarged view of the valve, and two steel strips about 4 inches long by $\frac{1}{2}$ inch wide by $\frac{1}{8}$ inch thick are riveted to the portion of uncovered leather. The valve is inserted into the pipe with the leather side outermost, and bolts are passed through suitable holes made in the pipe and the two steel strips, securing the valve firmly in position. The tendency of the valve is to remain open until water or other pressure in the pipe forces the butterfly wings up against the inner surface of the pipe.

If the pipe line is laid in a country where changes in the contours of the supplying stream are likely to cause corresponding changes in the lay of the pipe, it is well to use pipes flanged at each end with angle iron and secured by bolts, rather than those with slip joints. Flanged pipes can be readily disconnected and put together again, and without damage, whereas the pulling apart of slip joints is generally attended with some stretching of the mouth of the pipe, which will subsequently cause trouble. The first cost of flanges is undoubtedly considerable, but they will pay for themselves in time, especially when wages are high.

Giants, or monitors, require to be set in the pipes carefully, and to be well secured to counteract the end thrust tending to push them off the pipes, and then must furthermore be loaded down, as otherwise they are sure to rise under the pressure. Deflectors, of which there are a number on the market, throw a compact and strong stream, but they are not so effective for cleaning the bed rock as the ordinary "hat" as miners call it, which is an appliance that can be made in the blacksmith's shop if required. It consists of a cylinder of steel pipe about 15 inches long by 5 or 6 inches in diameter, according to the size of nozzle wanted, with bands of iron riveted on it to secure it to the pipe and nozzle by means of threaded bolts.

It has been found by experience that under average conditions, with a 4-foot flume and a grade of 4 inches in 12 feet, 1 cubic foot of water per second at 200 pounds pressure will take out and wash about 100 cubic feet of gravel per 24 hours. Of course, rocky ground requires more water than that composed of finer material, and deposits which have a quantity of clay intermixed may sometimes need the aid of explosives to disintegrate the material before the water can operate on it properly.

To find the rate of discharge of the nozzle an approximate estimation is made as follows: Multiply the square root of the effective head in feet by 8.03; this gives the velocity (theoretically) in feet per second, which, multiplied by the area of the discharge end of the nozzle in feet, will give the discharge in cubic feet per second. This is the theoretical figure, but in practice it is safer to multiply this by .75, in order to make due allowance for friction and other losses; or, to put it more simply, in the first multiplication use 6.02 instead of 8.03 for the multiplier. Losses due to friction and air resistance may be taken as about 16 per cent.

In hydraulic mining the term ground "sluice" should properly be applied to a rocky channel carrying water and gravel from the bank to the sluice box or sluice. In working the ground, the water that passes through the giant or monitor is not sufficient in volume to carry away the amount of gravel that it breaks down, which collects in what is known as a "pit." To meet this difficulty a ditch is made, leading from the main supply and delivering a stream at the pit, which "bank" or "waste" water, as it is called, is generally more than equal in volume to that coming through the giant. It is the object of the "piper," or miner, to keep this water in hand, as it is, of course, of little service if dispersed, and accordingly he makes a ground "sluice" down which the water carries the gravel on its way to the sluice. The sluice itself is the channel into which the gravel is run to be washed and deprived of its gold, which is deposited and subsequently recovered.

The upper end of the ground sluice should be provided with "wings" or bottle-necked openings to guide the material into it, and prevent any risk of the gold escaping. There is no specific length for these wings, as this is a factor that more or less depends upon the circumstances of the particular case, but in any circumstances they should be of considerable height, especially when bed rock is being

swept at the finishing of the pit, in order to obviate risk of gold being forced over the top of the rebound of the water.

Sluice boxes are built on various grades, ranging from 2 inches to 8 inches for the box of 12 feet. The grade is usually governed by the dumping facilities; but, presuming that the dump has not to be reckoned with, the grade will generally be arranged in accordance with the kind of the gravel that is being worked. For example, if the bank contains much rock, it is what is termed heavy ground, and requires a steeper grade than light gravel, which contains a large proportion of sand; again, rounded gravel will run on a flatter grade than flat or angular gravel, as it will roll where the latter will lodge and gradually collect. There is considerable "knack" in running gravel, much more than might be imagined, for one man will often run a far larger quantity than another.

Apart from a steeper grade assisting the gravel to run faster and more freely, it has the further advantage of "roughening" the water, which helps the gold to precipitate. In fact, the rougher the water the better the precipitation, and to serve this end it is also good practice in laying out a sluice to arrange for several sudden drops in the level of the floor, which aid in disintegrating the material and releasing the gold.

Sluices should be not less than 500 or 600 feet in length, the longer the better, and they should be made with as few bends as possible. When these cannot be avoided it is advisable to give a slight amount of superelevation to the outside edge of the floor, as this helps the material along, and the tendency of the water on the inside of the bend to go slowly is counteracted. Of course, care must be taken to render sluice boxes water-tight, as any quicksilver that travels down will escape; in fact, it will get through where water cannot.

The bottoms of sluices are paved with blocks of various materials, rock, wood, and iron. Iron is not in general use, on account of the expense, though some types of iron riffles on the market are very convenient, as they can be taken out in sections when the time comes for cleaning up. They are also good gold savers. Wood riffles are usually in the form of blocks made by cutting a tree into 10-inch lengths, which are fitted into the flume as close together as possible, and secured by means of strips nailed across from side to side. The writer is not much in favor of wood riffles, except where the water supply is small for several reasons; the gold does not readily precipitate between them, traveling some distance before doing so, and when it does the wood absorbs considerable, so that it is a common practice to burn the blocks after use, when a quite appreciable quantity of gold is recovered by panning the ashes; moreover, the method of securing the blocks increases the labor of taking them out. When rocks are employed as riffles they must be of a fairly uniform size and of a hard nature. What are known as boulders are good, but quartz is the best, as it is hard and does not wear or break up, besides being easy to clean. Rock is put in on much the same plan as wood riffles, but does not require holding-down strips, since it does not float. It is advisable, however, to nail a cross-piece into the sluice box at intervals (usually a piece of pole is chosen), for the purpose of preventing the whole series of rocks from washing down in the event of a section becoming dislodged.

Speaking generally, the method of riffling adopted conforms usually to a particular operator's idea, and in some degree to the conditions of working. Rock riffles are sometimes used in the upper part of the flume, where the larger part of the gold is saved, and wood is employed lower down. So far as the actual advantages in gold saving are concerned, it must be remembered that the riffles are often completely covered by gravel, and are only visible at the clean-up.

However that may be, the percentage of gold that travels a great distance down the sluice is comparatively trifling, that which gets away being rusty or adhering to quartz in such small amount that it does not appreciably increase the weight of the rock. Flour gold will travel some distance at times, and so will flat gold if the water is smooth, hence the desirability of planning the sluice so as to have comparatively rough water.

There is a diversity of opinion with regard to the proper width for a sluice. Some men are inclined to favor wide and shallow sluices, whilst others prefer them comparatively narrow and deep. In the same way, some at the outset aim at a complete saving of the gold values, with a consequent restriction in the amount of gravel washed, whilst others, after practical experience, make it their purpose to get as much gravel through the sluice as possible, and, if they lose a certain percentage of gold in the process, consider that they are repaid by the greater quantity run through at a smaller cost. Speaking generally, the sluice should be built in accordance with the water supply, and if a depth of water of 2 feet can be ensured in the sluice this will be enough to carry the boulders through, with sufficient force to keep the channel clear. A volume of water such as this implies, moving at the rate of 8 or 9 miles per hour, has a tremendous force, especially when loaded with debris of various kinds.

There are many contrivances adopted for the catching of gold that has traveled too far. Mercury traps have been tried, but they do not generally find favor on large hydraulic mines, the time taken in looking after them at the expense of the gravel output hardly paying for the extra value they might save.

In mines where the gold is finely divided or is found to adhere somewhat strongly to the fine quartz, an undercurrent is sometimes put into the sluice, preferably just above one of the "drops" alluded to. For this purpose, a section of the bottom of the sluice is left out, and the gap covered with bars of iron placed just far enough apart to allow the finest material to get through them, but not providing a sufficient passage to draw off so much of the water from the sluice as to stop its proper working. Below the bars, which are of round iron, or railway rails if these are more readily available, is a shallow box or tank about 20 feet square, arranged generally with a drop of about 20 inches to one end, which is paved with riffles formed of hard wood in strips or bridge rails. The fine stuff that drops through the "grizzly" spreads over this surface and drops its gold on the riffles.

It is customary to try to return the water thus diverted back to the sluice whence it came in order to prevent waste; hence the desirability of arranging the undercurrent in the neighborhood of a "drop." Care must be taken, however, in running a side sluice into the main, to do so at a very acute angle, otherwise trouble will ensue. Sometimes the point of reentry is arranged to give a drop of some little height to the returning water, but this is not good practice in the writer's opinion, as it tends to impede the flow of water in the main.

Having determined the water supply, an almost equally necessary requirement is to inspect the facilities for dumping, for in this method of mining it is a question of shifting, not tons, but millions of tons, of gravel from one side to another. For this is needed either a considerable valley or a swiftly running river that will carry off the debris. In the latter instance care must be taken to ascertain that the river will not be dammed by the quantity of gravel dumped into it, and equally that no damage will be done to property lying farther down stream, such as power plants, farms, etc. Much of the placer mining in California had to be stopped on account of the debris spreading over agricultural lands after its discharge into rivers.

The location of the dump has also to be decided with some reference to its position as regards the mine, so as to secure the requisite drop for the sluice. A good plan consists in taking the levels from the point of work to the point of dump, to find what grade can be allowed to the boxes. In practice it is not advisable to try to run gravel on a grade of less than about 3 inches to the box of 12 feet, which means a grade of approximately about 2 per cent. In making these calculations care must be taken to find the depth of bed rock at the bank, as if this is overlooked it may be discovered too late that the grade is far less than was calculated. This can be readily understood in the case where the depth from the top of a bank to be worked down to bed rock is 40 feet or more. Perhaps the safest plan to adopt is to find the bed rock at the point of dumpage, and work the grades backward from there to the works.

After installing the requisite plant, in the shape of water supply to the mine, the hydraulic appliances for attacking the gravel bed, and the washing down sluice and dump, the first week of operation is usually well occupied in breaking bank and washing away the top barren "dirt," and the pipe is seldom turned toward the sluice until the "sweeping in" process is started. This is the term used to describe the operation following upon the period when most of the gravel brought down has been sluiced into the sluice by the water used in breaking down, and the concentrate, in the shape of fine material, remains on the bed rock. Most of the gold is found in this concentrate. At this stage of the work the giant is removed and set back at a point of the pit commanding the whole area; and the concentrate is swept off the pit and into the sluice until nothing is left but the bare bed rock. It is for assisting in this operation that the wings at the head of the sluice, are provided, and the sluice should not be nearer to the face of the bank than from 30 to 50 feet, as the bank is always liable to cave and damage both wings and sluice.

It is advisable to dig out a depth of about 2 feet of ground immediately at the head of the sluice, and to sink some boards so that they come flush with the door of the sluice, in order to prevent the stream from the giant undermining it, and for the same reason it is necessary to nail a cross-piece firmly above the first set of riffles in the sluice to prevent them from being driven down stream by the force of the water.

The clean-up in hydraulic mining is undertaken after all the boulders and heavy stuff have gone down the sluice, leaving perhaps a foot of gravel or less remaining on the floor. This is run off by turning in a head of water until the paving is left clean to the tops of the riffles, only the interstices being filled with concentrate. The mercury for amalgamation is not run into the sluice generally until a week or more after the pit is started, or about the time when the sweeping-in process is started, as it is only then that the gold is carried down in a form likely to become amalgamated. Men are then put to work in the sluice with picks to loosen the riffled paving, which is further washed until quite clean, when it is thrown out and the concentrate is left on the floor. This will consist of fine gravel, slime, and gold, the latter not being visible in any appreciable quantity. A further small flush of water is used to move what is left in the sluice, and henceforth the amalgam will begin to appear as a silver streak behind the slowly moving concentrate.

A special clean-up shovel is used, having a perfectly flat bottom and sides about an inch high. Into the back of the shovel is fitted a piece of sheet steel about the same height as the sides and inclined at an angle of 45 degrees, care being taken that it makes a tight joint with the bottom and sides of the shovel. Holding the tool in the ordinary way, a man stands in the running water in the sluice, facing down stream, and buries his shovel in the solid matter in front of him; then, turning so as to face in the opposite direction, he pushes the shovel against the flow of the stream, which has the effect of washing the lighter material over the sloping back of the shovel, leaving the amalgam behind, which is transferred into a suitable receptacle, either an iron bucket or what is known as a "granite-ware" pail. This operation is continued until the paving is reached.

No matter how well a sluice may be constructed, it will be found that there are always some particles of amalgam to be saved from cracks or corners after the shoveling, and these have to be picked up by means of "amalgamated" spoons made of copper, shaped like a teaspoon, but narrower. These are dipped first in a solution of nitric acid, and then into mercury. When coated in this manner particles of amalgam brought in contact with the spoon will adhere to it, and may be transferred to the bucket, where a smart tap releases them. This process, which is called "picking," will recover every particle that is in sight.

After the clean-up the sluice is ready to be paved again, unless it has to be torn up and removed to another site. In that case, the nails joining the sections are punched out, and the separate boxes can be lifted out bodily and drawn away by teams to any desired distance.

Mines and Minerals

Vol. XXXII—No. 9.

SCRANTON, PA.—APRIL, 1912—DENVER, COLO.

Price, 25 Cents

PUBLISHED MONTHLY AT SCRANTON, PA.

ESTABLISHED 1881

INTERNATIONAL TEXTBOOK CO., PUBLISHERS

T. J. FOSTER, President S. P. ALLEN, Secretary E. H. LAWALL, Treasurer
 RUFUS J. FOSTER, Vice-President and Manager
 EUGENE B. WILSON, Editor ARTHUR J. HOSKIN, Associate Editor
 WESTERN EDITORIAL OFFICE: 1221-1222 First Nat'l Bank Bldg., Denver, Colo.
 CHICAGO OFFICE: 1006 Michigan Ave.

Entered at the Post Office at Scranton, Pa., as second-class matter
 Address all business communications to MINES AND MINERALS, Scranton, Pa.
 CABLE ADDRESS, "RETSOF, SCRANTON"
 LONDON OFFICE: INTERNATIONAL BUILDINGS, KINGSWAY, LONDON, W. C.
 SOUTH AFRICAN OFFICE: MANSION HOUSE CHAMBERS, ALDERLEY STREET,
 CAPE TOWN.
 NEW ZEALAND OFFICE: 63 DIXON STREET, WELLINGTON.
 AUSTRALASIAN OFFICE: 83 PITT STREET, SYDNEY.

SUBSCRIPTION RATES

Single Copies..... 25 cents
 Yearly Subscriptions, including postage:
 To United States, Mexico, Cuba, Porto Rico, Hawaii, and Philippines. \$2.00
 To Canada..... 2.50
 To all other countries..... 3.00
 The date after your name on the wrapper is that of the month to which your
 subscription has been paid. If you do not want to continue your subscription
 after that time, kindly notify us.

Notice to discontinue or change of address should be sent to the Scranton
 office.

When notifying us of a change of address always give your FORMER as well
 as your present address.

TABLE OF CONTENTS

EDITORIAL—	
Ore and Coal Mining Problems—Mine Officials of the Future—Tech- nical Education—Self-Appointed Fiduciaries of Mining.....	513
COAL MINING AND PREPARATION	
OVERCASTS WITH LIGHT WALLS, by A. A. Steel.....	515
BRITISH RESCUE AND AID ACT.....	516
A MOTOR CAR FOR MINE-RESCUE WORK.....	517
GLÜCK AUF, by C. L. Bryden.....	517
MINING COST CHART, by Carson W. Smith.....	518
FIRST AID SAVES LIFE.....	519
ENGINEERING SOCIETY NEWS.....	519
OBITUARY—	
George Jarvis Brush—Richard Palmer—John Maguire.....	520
CONSTRUCTION AND APPLICATION OF CURVES, by A. R. Dennington.....	521
KENOVA-QUADRANGLE COAL STRATA.....	522
COAL MINING NOTES.....	522
LESSONS FROM RECENT MINE DISASTERS, by Dr. Joseph A. Holmes.....	524
WANTED—COAL MINE MANAGERS, by Eli T. Conner.....	526
1911 BITUMINOUS MINE LAW OF PENNSYLVANIA.....	527
TRADE NOTICES.....	528
BY-PRODUCT COKE OVENS IN AMERICA, by F. E. Lucas.....	530
AUTOMATIC DRAINAGE.....	531
AN EFFECTIVE AIR HUMIDIFIER.....	531
MINE GAS INVESTIGATIONS, by G. A. Burrell.....	532
CATALOGS RECEIVED.....	533
MINE STABLE MANAGEMENT, by Beverly S. Randolph.....	534
CORRESPONDENCE—	
Correction—Position of Stoppings to Withstand Explosion—Tests for Oil Wanted—Accidents During Second Ten Days of Month— Capacity of Siphon—Legal Interpretation of Technical Terms— Humidifying Mine Air—Coal Washing.....	535
CHINESE COAL FOR THE UNITED STATES, by S. S. Knabenshue.....	537
FLUSHING APPLIANCES IN GERMANY.....	538
MAKING A CARBOARD INK STAND.....	538
BIG BLAST AT STEINS, N. MEX.....	539
BOOK REVIEW.....	540
PERSONALS.....	541
WILKES-BARRE MINING INSTITUTE BANQUET.....	541
SPIRAL FOR RAISING ROPE TO KNUCKLE.....	542
EXAMINATION QUESTIONS—	
Pennsylvania Bituminous Second-Grade Mine Foremen's Certificates.....	543
ORE MINING AND METALLURGY	
MIAMI CONCENTRATING MILL, by C. E. Golding.....	545
THE COKER CREEK GOLD FIELD, by Geo. H. Ashley.....	547
LEADVILLE, COLO., FISSURE VEINS, by Oliver C. Ralston.....	549
FUNDAMENTALS IN TECHNICAL EDUCATION, by Regis Chauvenet.....	550
BROWN HEMATITE MINING IN VIRGINIA, by Charlton Dixon.....	553
HOMESTAKE EMPLOYEES AID FUND, by Jesse Simmons.....	555
FOLLOWING THE ORE IN JOPLIN MINES, by L. L. Wittick.....	556
SINTERING FINE IRON-BEARING MATERIALS, by James Gayley.....	559
MECHANICAL DRYING FURNACES, by John S. Nicholl.....	561
PORTLAND MINE AND MILLS.....	562
ORE MINING NOTES.....	563
AN OIL-FIRED CONVERTER, by Frank C. Perkins.....	565
UNWATERING TRANSVAEVEAN MINE, CORNWALL, by Cyril Brackenbury.....	566
CLOTH PINIONS FOR ELECTRIC MOTORS.....	570
STRAITON'S INDEPENDENCE MILL.....	570
THE TESORERO MINE AERIAL TRAMWAY, by Frank C. Perkins.....	571
SOME KALGOORLIE HOISTING ARRANGEMENTS.....	572
THE AMHERST, QUEBEC, GRAPHITE DEPOSITS, by Fritz Cirkel.....	573
PHONOLITH AS A FERTILIZER.....	574
SQUIBS—	
The Clinkering of Coal, 526—Pressure Formula, 536—Flushing Appli- cances in Germany, 538—The Talc Industry, 547—Nickel-Zinc Alloys, 555—Radium in Australia, 558—A Pulverizer for Assayers, 560—Minerals in China.....	572

Ore and Coal Mining Problems

IN OUR last issue we published an interesting article by Mr. C. A. Tupper, consulting engineer, of Milwaukee, on the similarity of ore and coal-mining machinery, and what each branch of the mining industry owes the other for its development. Mr. Tupper wrote from the standpoint of a mechanical engineer with extensive experience in the designing of mining machinery. The mining engineer who has not confined his observations exclusively to the branch of mining in which he is actually engaged, realizes that in mining methods also there are frequent similarities, and that in methods as well as in machinery, each branch is indebted to the other for many important practical ideas.

There is no monopoly of brains in either branch of the industry, but, eliminating metallurgy, and speaking strictly of mining, it must be conceded that coal mining presents more complex problems to be solved than does ore mining. As many of the solutions of such problems can be adapted to overcoming difficulties in ore mining, it pays the ore mine official to read carefully prepared and well illustrated articles dealing with practical coal mining. Conversely, it pays the coal mine official to read similar articles on ore mining, for there are certain points in which the ore mine official is as far in advance of the coal mine official as the latter is in advance of the former in other points. To be an up-to-date mining journal, a publication must therefore cover both coal and ore mining methods. Otherwise, it is not giving its readers the service they have a right to expect.



Mine Officials of the Future

WE PUBLISH in this issue a short article by Mr. Eli T. Conner, mining engineer, on the necessity of educating and training young men for official positions at coal mines. This necessity is not a recent one. It has existed since the birth of the coal-mining industry, but in America, owing to our original enormous coal supply and shortsightedness, it was not realized as it is now by many mine owners and mine managers. The fact that so large a percentage of the coal mine workers of today are men from central and southern Europe, unfamiliar with the English language, and with habits of living very different from American standards, does not mean that the source of supply from which to draw young men susceptible to training and education is limited.

Experience has shown that the children of emigrants from southern and central Europe are mentally bright, and that they make as rapid progress in the public schools

as do the children of native-born parents, or those of parents from northern or western Europe. They also quickly assimilate American methods of living, and American ideas generally. Therefore, they are just as competent to absorb education and training, both general and technical as were the sons of the emigrants from northern and western Europe. In fact, there are a large number of young Slavs, Magyars, Lithuanians, Poles, and Italians devoting a large portion of their leisure hours to study to fit themselves for official positions in the mines, and for other occupations, including what are generally termed the "learned professions." Some of them are now successfully filling positions as certificated mine foremen. Others have succeeded in other occupations. Young attorneys, physicians, and clergymen, who were either natives of southern or central Europe, or who are the sons of natives of those sections of the continent, have already proved that the material exists in the families of these mine workers from which able and aggressive leaders in industrial pursuits can and will be recruited.

采 采

Technical Education

IF ONE is familiar with the catalogs issued nowadays by the institutions of technical education in the United States, he will appreciate some of the comments in the article by Regis Chauvenet elsewhere in this issue. It is amusing to contemplate the utter futility of a single youth assimilating the veriest fundamentals of the multiplicity of subjects propounded as "courses" leading to some of the engineering and scientific degrees. We have before us a recent announcement of a technical institution which states: "The specified work of the senior year covers the following subjects: Electro-Chemical Analysis, Theoretical Chemistry, Physical Chemistry, Industrial Organic Chemistry, Technology of the Non-Metals, Electrometallurgy, Metallography, Assaying, Geology of the Non-Metals, Ceramic Geology, Rare Metals, English." There arises the inquiry as to whether it is really possible for a student to perform useful work when his efforts are dissipated into so many channels. This and other vital questions will be found answered in the series of papers prepared for MINES AND MINERALS by the eminently capable Doctor Chauvenet.

This writer knows whereof he speaks. He is a member of a distinguished scientific family. He was given the best education attainable in his youth. He has traveled widely, always grasping knowledge everywhere. He is a keen investigator. At present he is a practicing engineer with many metallurgical and mining interests. For years he was president of the Colorado School of Mines, building it up from its beginnings. He has visited most of the engineering schools of the world, and he knows the history and accomplishments of them all. At present, he has in press a book on Stoichiometry that will cover many scientific points not given in any other books.

We know our readers will be well repaid for the time

spent in perusing this and the following articles published under the general title of "Fundamentals in Technical Education." The subsequent numbers will deal primarily with the essentials of education for mining and metallurgical engineers, and it will be shown that colleges and universities can properly lay no exclusive claim to the *sine qua non* that is so familiarly assumed by them. In the commercial language of the day, "results count," and this being true, it matters little how a skilful engineer acquires his knowledge and ability. Experience is said to be the best teacher, but our present author prefers to make certain rational amendments to this broad assertion, as will appear.

采 采

Self-Appointed Fiduciaries of Mining

IN THE correspondence column of this issue will be found a letter from A. H. Ricketts, Esq., of San Francisco, who is the author of the recently published book, "Ricketts on Mines." One sentence in this letter furnishes sufficient food for reflection to last mining men some time; it is as follows:

"I am forced when writing a law book to accept the published and judicial interpretations of mining and scientific terms as defined for purposes of *justice* by the Supreme Court of the United States and other tribunals of Federal and State judiciary."

This sentence shows that men ignorant of mining and mining terms can contort and twist the definition of well-established words to suit the exigencies of their particular cases, and that self-appointed fiduciaries of mining determine the definitions of technical words, thus becoming the irresponsible lexicographers from which no appeal can lie. It would seem to the layman that it was not within the province of lawyers to make definitions for well understood technical terms, but to interpret them as found.

In Vol. VI, page 685, of the Mineral Industry, Dr. R. W. Raymond paid his compliments to the self-appointed fiduciaries as follows: "To the generally loose, clumsy, and incorrect use of English in the Act of 1872, Section 2323 forms no exception. The hand that could write 'apex' meaning not a point, nor a line, but the total thickness of cross-area of a vein nearest the surface, and could describe the 'extending' of horizontal surface lines 'downward vertically' was quite competent to label a cross-adit 'tunnel.'"

Fewer lawyers and more practical business men should be elected to Congress and state legislatures, as experience has shown that the average lawyer lawmaker is unable to draft a law on any business proposition which is not full of meaningless words for future litigation, or which is, in a large measure, if not wholly, impracticable.

The Mining and Metallurgical Society of America have drafted a set of mine laws which the American Mining Congress hope to have passed, so that a uniform code will prevail throughout the various states. As conditions are today, thanks to self-appointed fiduciaries, if a man invests in a mining claim in the West he is in grave danger of investing in a lawsuit as well.

COAL MINING AND PREPARATION

Overcasts With Light Walls

Method of Construction That Will Afford Relief for Explosion Pressure and Can Be Readily Repaired

By A. A. Steel*

To promptly recover a mine after a severe explosion, it is necessary to restore the ventilation in more than one entry at a time, and this requires some form of overcast in a fairly effective condition. Explosion-proof overcasts can only be made by driving tunnels above some solid rock stratum, and from behind solid pil-

lars of coal, and there will be no feasible way to remove the waste without an opening to be afterwards closed by a stopping. In many mines the overlying strata are so weak that an explosion would cause a heavy rock fall at such an overcast. The ventilation of this rock tunnel will be difficult, and an effective rock tunnel is

forbidden in some states by laws requiring a cross-cut every 30 feet. For these reasons, it seems best to protect the main structure of the overcast by providing ample relief passages for the pressure caused by an explosion.

Fig. 1 shows a design for such an overcast to carry a 10-foot air-course over a parting 14 feet wide. It will be noticed that the main frame of this overcast is sheltered as much as possible by solid coal or rock. For this purpose, both the entry and the air-course

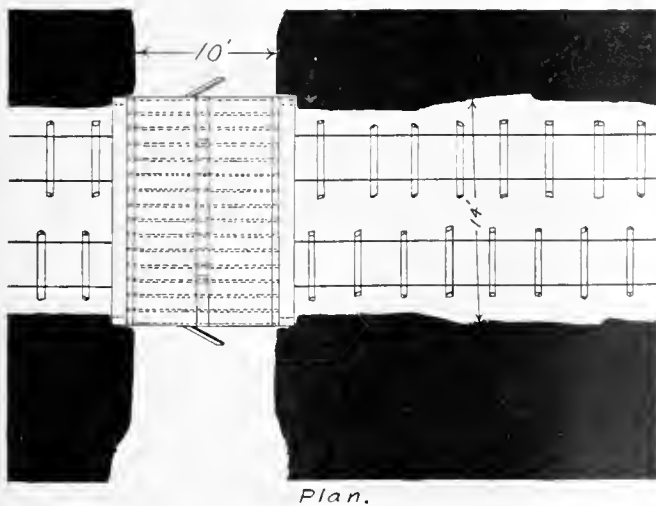
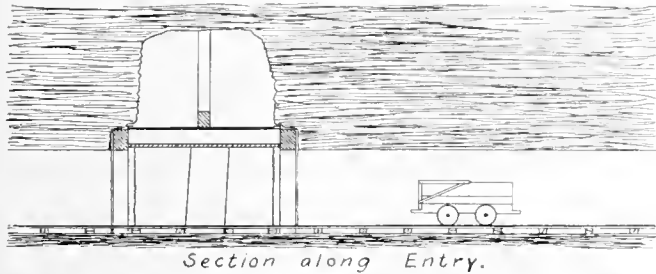
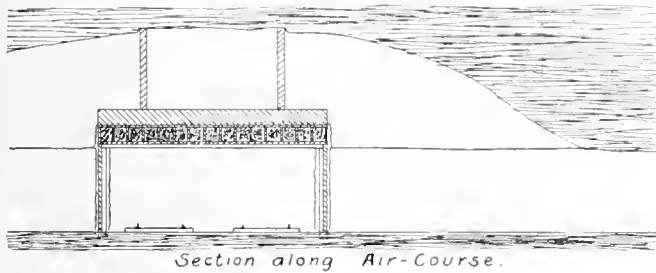

FIG. 1. PROTECTED OVERCAST WITH LIGHT WALLS

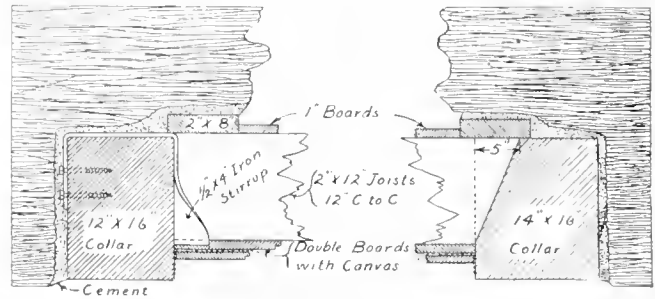

FIG. 2. DETAILS OF OVERCAST

should first be driven a foot or two narrower than the intended width and then widened by pulling down all loose coal and dressing the walls smooth with a pick. These smooth walls will reduce the size of air-course needed and the width of the overcast can be further reduced by making the cut in the rock higher than is at present customary. All spaces between the timbers and the coal or rock should be packed solid with strong cement mortar.

To proportion the members of the overcast for equal strength, the roof and the main frame are designed just strong enough to support a quiet downward load of 20 pounds per square inch, or nearly a ton and a half per square foot, in addition to its own weight. The posts are made as wide as the collars to give sufficient bearing area; this gives them much surplus strength as columns and will make them more secure against blows from derailed cars.

Table 1 gives the size of collars and the size and spacing of the joints for overcasts of various sizes to resist 20 pounds per square inch downward pressure if fair yellow pine is used. It should be noted that short overcasts will be much cheaper than the long ones of the same strength.

TABLE 1. DIMENSIONS OF TIMBERS OF OVERCASTS

Width of Air Course Feet	Width of Entry in Feet	Size of Collar in Inches	Size of Legs in Inches	Size of Joist in Inches	Spacing of Joist in Inches
6	8	6x10	6x10	2x10	20
	10	6x12	6x12	2x10	20
	14	12x12	8x12	2x10	20
8	8	6x12	6x12	2x12	16
	10	8x12	6x12	2x12	16
	14	12x14	12x12	2x12	16
10	10	10x12	6x12	2x12	12
	14	12x16	12x12	2x12	12

If beams of about the same size of the collar be placed above the overcast and braced against the roof by two props at one-fifth the length of the beam from the ends, the overcast will not fail from upward pressure until the force equals 80 pounds per square inch. This construction is especially advisable if the entry carries the intake air-current. In this case, the main shock of the explosion will be from the entry toward the air-course. A smaller beam and more props would be cheaper for the long overcasts. If a cheaper overcast is desired, a 10'x14' overcast to resist only half

*Professor of Mining, University of Arkansas, Fayetteville.

as much pressure will require 2"×12" joists spaced about 22 inches center to center, and 10"×12" collars.

Fig. 2 shows two suggested details for framing the roof. Both of these have about the same ultimate strength as the beams, but will yield somewhat by crushing of the wood before the beams will break. The iron stirrups are a more nearly standard construction for buildings, but are more expensive. The beveled notch in the beam can be used only if the collar is made from 2 to 4 inches wider than the dimensions given in the table. It is also necessary that roof rock be so strong that the beams cannot be forced apart. Because the joists must be held down by wedging against the rock, it will be necessary to frame the overcast a foot or so below its final position and to jack it up after the joists are in place. Cement should be packed in above the collar to make a tight joint before the 2"×8" is put in.

To lessen the grip of the explosive blast, both top and bottom of the roof should be covered with smooth boards. To prevent leakage either the top or bottom covering should be double with tarred canvas between the layers. The resistance of the overcast to a sudden shock can be greatly increased by weighting it with stone and sand between the joists. This should be well packed in.

The side walls of the overcast can be made with two layers of inch boards with tarred canvas between and supported at the top against a 2"×4" nailed to the roof so as to resist ordinary windy shots only. If necessary, doors for the convenience of the fire boss may be placed in these partitions, if they are made self-closing by leaning the hinges and if they open against the air pressure. In case these walls are totally destroyed, and the roof remains substantially intact, the side walls can be replaced by brattice cloth and ventilation restored in a few moments. Even if the entire overcast is destroyed, the smooth niche in the coal and roof will make it much easier to build a canvas overcast on a wooden frame than in the case of any style of masonry overcast.

The extra cost of such an overcast is chiefly in the extra labor of preparing the entries. This will be repaid by reduced maintenance. This overcast is very much cheaper than a rock tunnel and just about as effective, because it can be restored as easily as the stopping leading to a rock tunnel can be replaced. Its disadvantage is the fact that it will rot, and if a long life is needed, concrete might be better, but the concrete should be provided with equally large explosion doors.



British Rescue and Aid Act

The following is an order made by the Secretary of State under Section 1 of the Mines Accident (Rescue and Aid) Act, 1910, of Great Britain:

In pursuance of Section 1 of the Mines Accidents (Rescue and Aid) Act, 1910, I hereby make the following order:

1. This order shall apply to all mines in which coal is worked, provided, however, that the Secretary of State may, if he thinks fit, exempt from the order any mine at which the total number of underground employes is less than 100 if the mine is so situated that in the opinion of the Secretary of State the organization of a Central Rescue Station from which it could be served, is impracticable.

2. No person, unless authorized by the manager or official appointed by the manager for the purpose, or, in the absence of the manager or such official, by the principal official of the mine present at the surface, shall be allowed to enter a mine after an explosion of firedamp or coal dust, or after the occurrence of a fire, for the purpose of engaging in rescue work.

3. (a) There shall be organized and maintained at every mine, as soon as is reasonably practicable, competent rescue brigades on the following scale: Where the number of underground employes is 250 or less, one brigade; where the number of underground employes is more than 250, but not more than 700, two brigades; where the number of underground employes is more than

700, but not more than 1,000, three brigades; where the number of underground employes is more than 1,000, four brigades. But the owner, agent, or manager of a mine, at which the total number of underground employes is less than 100, shall be deemed to have complied with this provision if he has acquired the privilege of calling for a brigade from a Central Rescue Station. A group of mines belonging to the same owner, of which all the shafts or exits for the time being in use in working the mines lie within a circle having a radius of 2 miles shall, for the purpose of ascertaining the number of brigades required, be treated as one mine. (b) A rescue brigade shall consist of not less than five persons employed at the mine, carefully selected on account of their knowledge of underground work, coolness, and powers of endurance, and certified to be medically fit, a majority of whom shall be trained in first-aid and shall hold a certificate of the St. John's Ambulance Association or of the St. Andrew's Association. (c) There shall be selected from the ranks of each rescue brigade one person or leader who shall act as captain of the brigade. (d) A brigade shall not be deemed competent unless (1) it undergoes a course of training approved by the Secretary of State; (2) after the preliminary course of training it undergoes in every quarter at least one day's practice with breathing apparatus, which practice shall at least twice in the year take place at the mines; (3) the members of the brigade shall have received instructions in the reading of mine plans, in the use and construction of breathing apparatus, in the properties and detection of poisonous or inflammable gases, and in the various appliances used in connection with mine-rescue and recovery work. (e) Arrangements shall be made at every mine for summoning members of rescue brigades immediately their services are required.

4. If it can be clearly proved that the necessary number of persons employed underground at a mine will not consent to form a brigade or brigades, or having offered their services fail to be trained or maintain their training, the owner, agent, or manager of the mine shall not be liable to any penalty, provided first that he has endeavored to the best of his ability to constitute the requisite brigade or brigades, and has afforded every opportunity to the persons employed at the mine to undergo the necessary training, and secondly that he has made a bona fide attempt to arrange for the supply from a central rescue station of such rescue brigades as he is unable to provide at his mine.

5. (a) There shall be provided and maintained at every mine suits of portable breathing apparatus in the proportion of two suits to each brigade required by Sec. 3 (a). The apparatus must be capable of enabling the wearer to remain for at least 1 hour in an irrespirable atmosphere, and must be kept ready for immediate use. The apparatus must be housed in suitable receptacles in a dry and cool room. The owner, agent, or manager of a mine shall be deemed to have complied with this requirement if he has acquired the privilege of calling for such of these appliances as he may not possess from a central rescue station, always provided that the central rescue station is situated within a radius of 10 miles from the mine and is in telephonic communication with the mine. If it can be shown that it is not possible, at the date of this order, to procure the aforesaid breathing appliances, owing to lack of supply, the owner, agent, or manager shall be deemed to have complied with this order if he procures such appliances as soon as is reasonably practicable. (b) There shall be kept at every mine tracings of the workings of the mine up to a date not more than 3 months previously, showing the ventilation and all principal doors, stoppings, and air-crossings and regulators, and distinguishing the intake air by a different color from the return air, which tracings shall be in a suitable form for use by the brigades. (c) There shall also be provided and maintained at every mine which maintains a rescue brigade or brigades: (1) Two or more small birds or mice for testing for carbon monoxide; (2) two electric hand lamps for each brigade, ready for immediate use and capable of giving light for at least 4 hours; (3) one oxygen reviving apparatus; (4) a safety lamp for each member of the rescue brigade for testing for firedamp; (5) an ambulance box provided by the St. John's Ambulance Asso-

ciation or similar box, together with antiseptic solution and fresh drinking water.

6. There shall be kept and maintained in every central rescue station not less than 15 complete suits of breathing apparatus, with means of supplying sufficient oxygen or liquid air to enable such apparatus to be constantly used for 2 days, and of charging such apparatus; and 20 electric hand lamps; four oxygen reviving apparatus; an ambulance box or boxes, provided by the St. John's Ambulance Association, or similar boxes, together with antiseptic solution and fresh drinking water; cages of birds. A motor car shall be kept in constant readiness.

7. Every central rescue station shall be placed under the immediate control of a competent person conversant with the use of the appliances.

8. There shall be adopted at every mine by the owner, agent, or manager such rules for the conduct and guidance of persons employed in rescue work in or about the mine as may appear best calculated for the carrying out of rescue operations, and the rescue brigade or brigades, if any, maintained at the mine shall be thoroughly instructed in such rules.

9. "Central rescue station" means a station established to serve several collieries.

采 采

A Motor Car for Mine-Rescue Work

By Frank C. Perkins

The motor car of the Durham and Northumberland collieries fire and rescue brigade, built by Sir W. G. Armstrong, is shown in Fig. 1. This fire-car has a capacity of seven firemen, one of whom drives. The purpose of this machine is to attend calls where rescue apparatus is required.

There are 10 liquid-air rescue devices carried in the box body of the machine. Two metal containers, each holding 52 pounds of liquid air, or a total of 104 pounds, are carried on a light angle-iron frame; one of these containers is shown back of the firemen. Suitable spiral springs attached to the top of the box hook and to the bottom of each container, prevent its swinging very far when the car is in motion.

It is maintained that the above quantity of liquid air is sufficient to charge the 10 rescue apparatuses for 3 hours' work each. A "pulumotor" reviving apparatus, with two spare cylinders, is carried in a compartment under the rear frame of the machine. There is also provided 2 miles of special light telephone wire wound on drums which hold one-eighth of a mile. These reels are carried in the foot-board boxes, together with two breast carriers for them. A heavier drum with a semiportable carrier is stowed in the box body. This drum with a semiportable carrier on which 880 yards of wire is wound is stowed in the box body. This is used when it is desired to establish telephone communication between the top and the bottom of the shaft.

Three portable telephone boxes are carried in the foot-board boxes, two of which can be used at either extremity of the line, and the third can be coupled in at any position on the line. Twelve electric hand lamps and a surgical haversack are also carried.

There is a special ventilating box on top of the foot-board boxes on the off side of this rescue car which contains four small bird cages, each containing a canary. The side and rear lamps can be used either as electric or oil lamps. In

the former case they are switched on from the driver's seat. It is of interest to note that dissolved acetylene is burnt in the head-lamps and these are lit electrically by means of a switch from the dash board. Detachable rims are fitted to the wheels and two spare rims complete with tires are carried and ample accommodation is provided for tools and spare parts.

It may be mentioned that for brigades using rescue apparatus of the oxygen type, arrangements could be provided for carrying 10 helmets and sufficient charges to last each 4 hours. The chassis is of Armstrong-Whitworth design with four speeds forward and reverse. A speed of 35 to 40 miles per hour can be easily obtained, and notwithstanding this, a hill of 1 in 3 with a full load can be negotiated without difficulty.

采 采

"Glück Auf!"

By C. L. Bryden

An American mining engineer traveling through the mining districts of Europe is greatly impressed with the ideas and ways of doing things so different from those of his own country.

There are many sayings in the German language that are beautiful and have a great depth of meaning. Often they are difficult to translate into English and some of them cannot be translated, but can only be described. One of these, common to the mining regions of Germany, is the familiar greeting at meeting and departure of friends, and the salutation of men going in and coming out of the mines. Everywhere one hears the greeting, "Glück auf!"

The pastor greets his parishioners with it, the business man his employes; the school children use it in saluting their school teacher on arriving and leaving school, and the miners seldom use any other form of greeting. In fact, all the people in the mining regions use it more or less, but generally with a different meaning from the meaning the miners and their associates put into it.

The people not actually working in or around the mines use it instead of "Guten Morgen" or "Wie geht's" and "Auf Wiedersehen." The miner puts his whole heart and soul into the saying and gives practically the same meaning to it as we do, when we say, "God be with you till we meet again."

As a usual thing, the American miner does not think of any salutation when he steps on the cage to descend to his daily work. Not so with the German miner. When the cage is lifted off the keeps and starts to descend, the headman calls out, "Glück auf!" and the men on the descending cage answer in unison, "Glück auf!" In the same way, on returning to the surface the same salutations are exchanged.

Here the headman wishes his comrades a safe trip to their daily work, with no accidents during the day and a safe return to the surface when the day's work is done. In their answer to the headman, the miners wish him a good-bye, implying that they hope to see him again when their day's work is over. On returning to the surface by the exchange of "Glück auf!" they imply such a meaning as, "By the hand of Providence we greet each other again."

After a person interested in mining has been associated with the German miners for some time and sees the feeling that is put into this greeting, he is convinced that it is not only one of the most beautiful sayings in the German language, but that it is as essential to the German miner as his daily lunch.

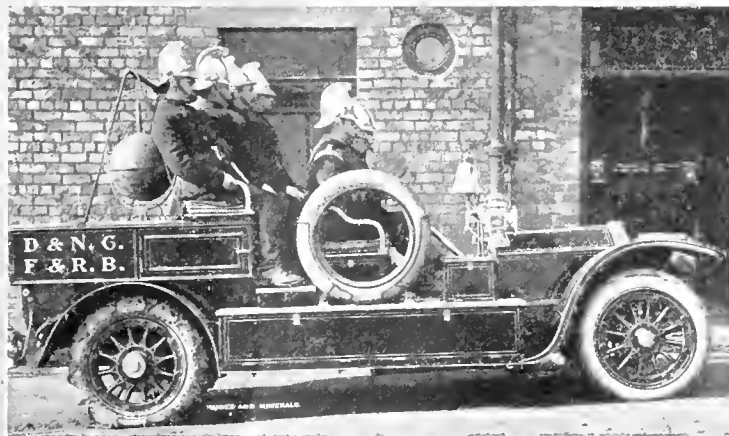

FIG 1 MOTOR CAR FOR RESCUE WORK

Mining Cost Chart

A Graphical Determination of Present and Future Profits and Showing the Influence of Tonnage on Costs

By Carson W. Smith

While this article was written by Mr. Smith with special reference to cost keeping at coal mines, it nevertheless is more applicable to ore mining, where contract mining is less in vogue than at coal mines. Mr. Leo Gluck, assistant to the president of the Pittsburgh Coal Co., has used charts for following as well as forecasting conditions at that company's numerous mines, as well as the total number of mines.—EDITOR.

The Consolidated Coal and Coke Co., of Denver, Colo., has devised and applied a graphical method of cost inspection, analysis, and determination, which presents some new points of considerable interest.

Coal-mine operating costs are difficult to forecast, and especially is it so in the Northern Colorado lignite field, in which is located the property of this company. With the numerous and conflicting factors which go to make up the total cost of operating any coal property, and the wide variation these factors as costs per ton suffer, due to fluctuations in the tonnage produced from period to period, it is always difficult to forecast with any satisfactory degree of certainty the profits to be expected for any future period, even under certain assumed and probable conditions.

The method herein outlined undertakes to solve this problem of future profit or loss in a graphical way by combining two curves, one of which represents the actual past performance of the mine in question, under certain known and fixed conditions, the other curve representing the limiting conditions under which the mine may operate profitably. These curves are drawn up in such a way as to separate and hold aside the unknown and variable factors for separate inspection, thereby eliminating one cause of much un-

In the broadest sense the only way to forecast costs is to project past costs into the future and base all computations upon them;

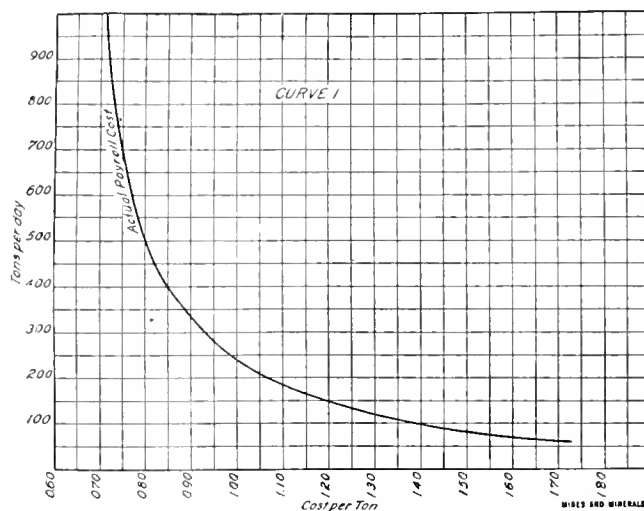

FIG. 1. FUTURE PAY ROLL COSTS AT MINE UNDER NORMAL CONDITIONS

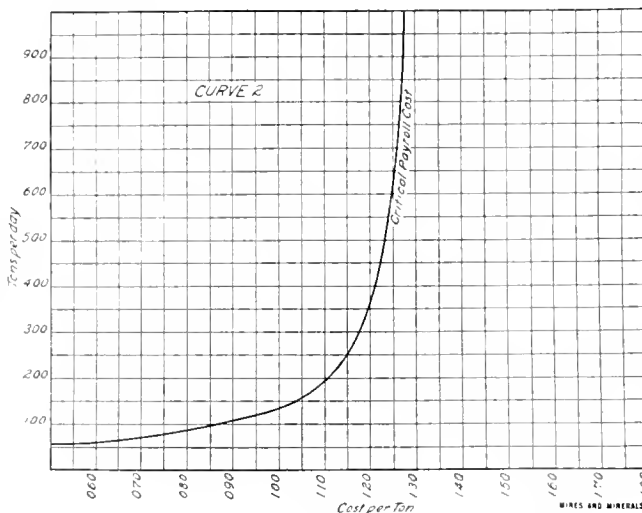

FIG. 2. LIMITING OR "CRITICAL" PAY ROLL COSTS AT MINE

however, due to the vast array of factors that govern costs, and especially the mysterious influence that a varying tonnage has upon costs and profits, any mathematical forecast seems bound to lead into uncertainties that largely tend to confuse. Now it is possible to determine, for a mine of several years operation and of a variable production, a fairly satisfactory curve representing the mere production or pay-roll costs per ton for a range of tonnages varying from the lowest tonnage produced per day at the mine to the highest, this curve representing costs under certain normal periods of known conditions.

Fig. 1 shows such a curve as determined for the Baum mine of the Consolidated Coal and Coke Company. This curve shows operating or pay-roll costs at the mine for a certain range of tonnages, the curve being drawn up as carefully as possible from past records of certain normal periods under definitely known conditions, and should hold good for future normal operation under corresponding conditions.

Fig. 2 shows a curve representing the limiting or critical mine pay-roll cost per ton for different tonnages per day. By "limiting cost" is meant that cost above which would be a deficit for the company and under which a profit would be shown. "Critical cost" properly defines it.

Curves 1 and 2 are combined in Fig. 3. One can readily see what interesting and useful information is shown by the combination, holding in mind always that the curves are both for mine pay-roll or operating costs; Fig. 1 representing the probable actual pay-roll cost, and Fig. 2 showing the critical pay-roll cost—the boundary line between profit and loss for the company. For instance, at an average possible production of 500 tons per day for the next month, what profit should be expected? Fig. 3 gives an instantaneous and reliable estimate. For 500 tons per day the pay-roll cost will be 80 cents (curve 1). The limiting or critical pay-roll cost for 500 tons per day is \$1.23 (curve 2). The difference, 43 cents, represents the gross profits per ton that may be expected.

As has been said, curve 1 represents operation under certain known and fixed conditions. Any variation in these conditions

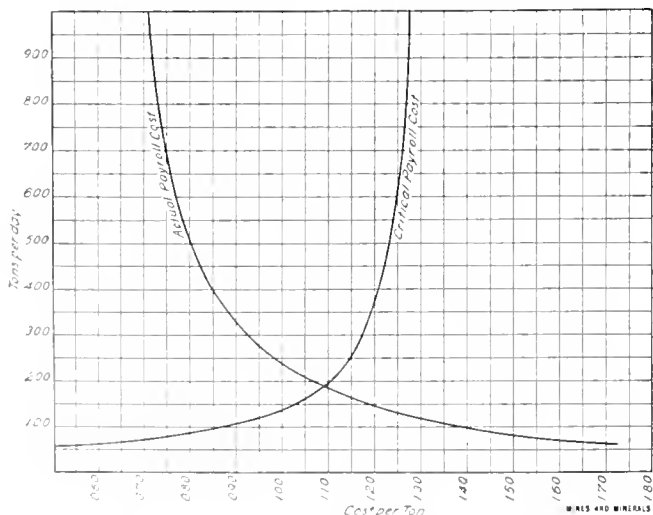

FIG. 3. PROFIT AND LOSS CURVES, COMBINING CURVES 1 AND 2

certainty and thus giving the greatest opportunity for the highest degree of accuracy.

either at the present time or estimated for the future, affects to a corresponding degree the net profit to be expected. One variable feature or factor in this cost that is always taken into consideration is the yardage cost. This varies from season to season according to the proportion of development work going on, and can be quite accurately foretold. The curve is plotted for a normal yardage cost of 9 cents per ton, but the cost ranges from considerably below this in the winter time up to 25 cents per ton in the summer time, when nothing but narrow work is being driven. Another factor is that of supplies; the gross profit shown by the curves is always subject to the supply cost per ton. By supplies is here meant all materials purchased, whether repairs, equipment, or otherwise. A few years experience and accounting has shown about what may be expected in this line; but as the supply cost is always decidedly erratic, it seems best to hold it as an entity outside of normal operating costs.

Another factor that will affect these "paper profits" is that of extraordinary or non-operative costs, a certain amount of which are bound to occur from time to time. By this such things are meant as lawsuits, a possible fire, a severe cave or squeeze, relining a shaft, etc., all of which must be considered in looking ahead at the future costs and profits. So really in estimating net profits for any future period from these two curves, these three things, yardage, supplies, and extraordinary costs, must always be forecasted as well as possible, and deducted from the shown gross profits.

A skilled mathematician could probably study these curves and make some very interesting deductions besides those shown so plainly. One of the most striking things shown, however, is the rate at which profits disappear and debits build up below a certain production. There seems to be likewise a "critical tonnage" for every mine below which the loss rapidly increases as the tonnage goes down, and above which the profits grow rapidly with every few additional tons gained per day in production. The combination of the two curves locates this point very nicely and right there affords a piece of information that would be worth a good deal to a great many managers. Also the curves give a quick and accurate answer to the perplexing question that always comes up when contracts are being made; namely, the question of the probable profits from the contract under consideration, at any given price; and further, the curves afford an intelligent method of properly determining the lowest price that can profitably be offered for a desirable contract. Such a determination at least gives a valuable check to the usual method of price making.

At first consideration it may seem impossible to accurately represent the critical pay-roll cost, as defined in this article, by a curve, but the fact remains that such a curve as shown in Fig. 2 does actually represent the conditions given; namely, that pay-roll cost per ton which cannot be exceeded without loss to the company. This curve is accurate to the extent of the accuracy of the figures from which its equation is derived and as such actually shows the critical or limiting cost of labor at the mine. The many uses to which a curve of this nature can be put are obvious, and a study of such a curve gives an interesting and pertinent rating to the financial soundness of the company and its existing contracts.

The idea embodied in these curves is not limited to coal mines and can be applied to other operations than mining with the same happy results.

來 來

First-Aid Saves Life

At the Diamond mine of the D., L. & W. Coal Co., West Scranton, Pa., a gas explosion occurred on March 15, which killed W. R. Davis, of Scranton, while three others were overcome by after-damp. McDonough, who was a partner of Davis, was knocked down, but revived sufficiently to crawl to the foot of the shaft and notify Sidney Baker, mine foreman. Baker's first call was for the first-aid team, but, with Davis dead and McDonough barely

able to move, James Green was the only first-aid man available. With bandages and stretchers Baker and Green started for the explosion. After 15 minutes the miners called David Davis, team captain, from the coal seam above, and he took with him Kelley and several volunteers to search for the missing men. Half way to the place where the explosion occurred they found Foreman Baker and Green unconscious. A short distance further they found Alexander Domshefsky. The unconscious men were placed on stretchers, hurried to pure air, and first aid applied by Davis and Kelley. For nearly an hour, assisted by fellow miners, they worked over their foreman before he gave signs of returning life. Green, the first-aid man, was the second to come around, and then the two first-aid men gave all their efforts to Domshefsky, who appeared to be dead. Domshefsky had been in the afterdamp so long that life was nearly extinct when the rescue men reached him, but they spared no effort in their work, and raised and lowered his arms until their own arms were as lead with the continued effort. Finally Domshefsky's eyelids wavered, there was a slight heave of his chest, and a minute later he breathed of his own will. He had been unconscious for an hour and a half.

Davis, the victim of the explosion, leaves a wife and four children. McDonough's crawl through the deadly gas was possible only by his keeping his head close to the ground, and his hands and face were cut and scratched and his lungs so filled with the fumes that it was with hard work he was resuscitated after he reached the foot of the shaft and told his foreman of the explosion.

來 來

Engineering Society News

American Institute of Mining Engineers.—The annual business meeting of the American Institute of Mining Engineers, held February 19, in the Engineering Society's Building, in New York, was largely attended. Action on the proposed amendments to the constitution, namely, change of name and increase in annual dues, was postponed, and a resolution passed appointing Messrs. Kemp, Corning, Stone, Nichols, and Ledoux a committee to study all the affairs of the institute, their report to be considered at a later date. The following papers were presented: "The Sintering of Fine Iron Ore," by B. G. Klugh, Birdsboro, Pa.; "Agglomeration of Fine Materials," by W. S. Landis, South Bethlehem, Pa.; "The Grondal Briquetting Process," by N. V. Hansell, New York, N. Y.; "Electrostatic Concentration or Separation of Ores," by H. A. Wentworth, Boston, Mass.; "Progress in Roll Crushing," by C. Q. Payne, New York, N. Y.; "Gold Hill Mining District in Western Utah," by Prof. James F. Kemp, New York, N. Y.; "Geology of the New Catskill Aqueduct," by Charles P. Berkey, New York, N. Y.; "Geology and Ore Deposits of the Silverbell Mining District, Arizona," by C. A. Stewart, University of Idaho, Moscow, Idaho; "The Decomposition of Some Metallic Sulphates at an Elevated Temperature in a Current of Air," by Prof. H. O. Hofman and W. Wanjukow, Massachusetts Institute of Technology, Boston, Mass.; "Vanadium in Pig Iron," by Porter W. Shimer, Easton, Pa.; "Temperature Conversion Tables," by Dr. Leonard Waldo, New York, N. Y.; "Treatment of Copper Mine Water," by Prof. Joseph W. Richards, South Bethlehem, Pa.; "Stagnant Mine Waters," by Prof. Alfred C. Lane, Tufts College, Boston, Mass.; "Rational Valuation and Quality Efficiency of Furnace Stock," by Prof. John Jermain Porter, University of Cincinnati, Ohio; "Bearing of the Theories of the Origin of Magnetic Iron Ores on Their Possible Extent," by Frank L. Nason, West Haven, Conn.; "Geology of Harrison Gulch in Shasta County, California," by H. E. Kramm, Ithaca, N. Y.; "Direct Determination of Small Amounts of Platinum in Ores and Bullion," by F. P. Dewey, Washington, D. C.; "An Early Discovery of Fuller's Earth in Arkansas," by J. C. Branner, Stanford University, Cal.; "Occurrence of Silver, Copper and Lead Ores at the Veta Rica Mine, Sierra Mojada, Coahuila, Mex.," by Frank R. Van Horn, Cleveland, Ohio; "A Concise Method of Showing Ore Reserves," by N. H. Emmons, Copperhill, Tenn.; "Study of Pre-Cambrian Rocks of the Harney Peak District, South

Dakota," by Gordon S. Duncan, London, England; "Treatment of Complex Silver Ore at the Lucky Tiger Mine, El Tigre, Sonora, Mex.," by D. L. H. Forbes, Toronto, Ontario, Can.; "Gold in Certain Copper Alloys, Soluble in Nitric Acid," by Edward Keller, Perth Amboy, N. J.; "Electrolytic Refining of Impure Copper," by Horace H. Emrich, Kyshtim, Russia; "Fuel Economy of Dry Blast," by R. S. Moore, New York, N. Y.; "The St. Helen's Mining District, Skamania County, Wash.," by Horace V. Winchell, Minneapolis, Minn.; "The San Nicholas Mining District," by I. H. Wentworth, Matchuala, Mex.; "Abrasion and Dust Losses in Ore Drying," by Carl F. Dietz and Dyke V. Keedy, Boston, Mass.; "The Smokeless Coal Field of West Virginia," by Edwin Ludlow, Eccles, W. Va.; "Sintering and Briquetting of Fuel Dust," by Felix A. Vogel, New York, N. Y.; "The Shumacher Briquetting Process," by Joseph W. Richards, South Bethlehem, Pa.; "Mine Lamps," by David B. Rushmore, Schenectady, N. Y.

Lackawanna Chemical Society.—At the annual meeting of the Lackawanna Chemical Society, the following were elected officers for the ensuing year: E. B. Wilson, president; C. L. Bryden, vice-president; W. L. Whitehouse, secretary-treasurer. After the dinner the society was addressed by Joseph W. Richards, Ph. D., Professor of Metallurgy, Lehigh University, who talked on Electrochemistry in Sweden and Norway.

Affiliated Student Societies.—Any society of undergraduates at a technical school, comprising students in any branch of engineering, metallurgy, chemistry, geology, etc., may be recognized by the Council of the American Institute of Mining Engineers, in its discretion, as an affiliated Student Society. The following societies have been placed on the list by the Council:

The Mining Society of the Sheffield Scientific School, Yale University, New Haven, Conn. President, Karl C. Stadtmiller; secretary, S. B. Gordy.

The University of Illinois Student Branch of the American Institute of Mining Engineers, Champaign, Ill. President, A. L. Voight; secretary, M. L. Nebel.

The Engineering Society of the University of Nevada, Reno, Nev. President, Walter Harris; secretary, E. R. Bennett.

The University of Wisconsin Mining Club, Madison, Wis. President, H. E. Schmidt; secretary, W. V. Bickelhaupt.

The Mining and Geological Society of Lehigh University, South Bethlehem, Pa. President, William E. Fairhurst; secretary, Carl W. Mitman.

The School of Mines Society of the University of Minnesota, Minneapolis, Minn. President, Emory P. Baker.

The Mining Engineering Society of the Massachusetts Institute of Technology. President, L. B. Duke; secretary, Lionel H. Lehmaier.

The Student Auxiliary Society of the American Institute of Mining Engineers of the University of Kansas, Lawrence, Kans. President, A. H. Mangelsdorf; secretary, C. J. Hainbach.

The Associated Miners of the University of Idaho, Moscow, Idaho. President, James W. Gwinn; secretary, J. Wallace Strohecker.

The State College of Washington Mining and Geological Society, Pullman, Wash. President, R. V. Ageton; secretary, W. M. McCarty.

The Tejas Technical Society, School of Mines, University of Texas. President, G. C. Cartwright; secretary, David S. Alley.

The Ohio State University Student Branch of the American Institute of Mining Engineers, Columbus, Ohio. President, Hugh B. Lee; secretary, E. P. Elliott.

The Stanford Geology and Mining Society, Stanford University, Cal. President, B. E. Parsons; secretary, E. D. Nolan.

The Senior Mining Society of Columbia University, New York, N. Y. President, Roger L. Strobel; secretary, Clark G. Mitchell. Mining Association of the University of California, Berkeley, Cal. President, W. E. De Berry; secretary, J. F. Dodge.

Tufts College Chemical Society, Tufts College, Mass. President, P. G. Savage; secretary, W. S. Frost.

University of Washington Mining Society, Seattle, Wash. President, Horace H. Crary; secretary, Clinton R. Lewis.

Student Branch of the American Institute of Mining Engineers, Iowa State College, Ames, Iowa. President, M. B. Hadley; secretary, R. L. Hurst.

Missouri Mining Association of the Missouri School of Mines, Rolla, Mo. President, D. L. Forrester; secretary, J. S. Irwin.

來 來 Obituary

GEORGE JARVIS BRUSH

George Jarvis Brush, the first director of the Sheffield Scientific School of Yale University, died in New Haven, Conn., February 8. Those who studied under and were brought in contact with him when Sheffield had comparatively few students always held him in respect, not only for his ability, but for his lovable qualities and the kindly interest he took in all. This respect increased until it had almost reached veneration at the time of his death. It was largely due to Mr. Brush that Sheffield was incorporated in 1861, and it is also largely due to him, as director from 1872-1898, that it has reached the commanding position it holds among the scientific schools of today. The following is a chronology of Professor Brush's life as recorded by himself in "Who's Who": George Jarvis Brush, mineralogist; born at Brooklyn, December 15, 1831; son of Jarvis and Sarah (Keeler) Brush; private school education; studied chemistry and mineralogy at New Haven; in October, 1850, went to Louisville as assistant to Professor Silliman in university there; Ph. B., Yale, 1852 (Honorary A. M., 1857; LL. D., Harvard, 1886); married Harriet Silliman Trumbull, of Colchester, Conn., Dec. 23, 1864; assistant in chemistry, University of Virginia, 1852-3; studied in Europe, 1863-6; Professor of Metallurgy, Yale, 1855-71; Professor of Mineralogy, 1864-98, Professor Emeritus, Yale, since 1898, Director Sheffield Scientific School (Yale) 1872-98. Fellow American Association for Advancement of Science (president 1880), American Academy of Art and Sciences; member National Academy of Sciences, Geological Society of London, Edinburgh Geological Society; honorary member Mineral Society of Great Britain; member St. Petersburg Imperial Mineral Society, Bavarian Royal Academy, American Philosophical Society, etc. Has written extensively on mineralogical topics.

RICHARD PALMER

Richard Palmer died at Parsons, Pa., March 14. Mr. Palmer came from England and settled at Ashland, Schuylkill County, in 1854. Later he became inside superintendent of William Penn colliery. He retained this responsible position for 30 years, and after the mine had been sold to the Susquehanna Coal Co. On account of age he retired a few years ago.

JOHN MAGUIRE

John Maguire, of Pottsville, Pa., died March 12, at Pottsville. Mr. Maguire, who was born in England, came to this country with his parents in 1852, and at 10 years of age began life as a slate picker at Saint Clair. In 1862 he enlisted with the emergency men in Co. C, Sixth Pennsylvania Volunteer militia, and was mustered out with his regiment. Again, in June, 1863, he enlisted as a private in the Thirty-Ninth Pennsylvania militia, when the second invasion, which terminated with the battle of Gettysburg, began. In February, 1864, he joined Co. F, Seventh Pennsylvania Cavalry, and after being mustered out at Macon, Ga., was honorably discharged at Harrisburg in 1865.

He next assisted in sinking the Pine Forest shaft at St. Clair. Here he became fire boss, assistant mine foreman, and in 1868 was made mine foreman. In 1881 he was transferred to Richardson colliery of the Philadelphia & Reading, and was appointed district superintendent in the Tremont district, where under his supervision, 95 per cent. of the coal was recovered at the Brookside colliery. In 1894 he was made state mine inspector. In 1902 he resigned to become division superintendent of the Philadelphia & Reading collieries south of Broad Mountain. He was a man of sound judgment and absolutely fearless in the performance of his duty.

Construction and Application of Curves

Methods of Making Diagrams to Illustrate the Effects of Varying Conditions and Forces

By A. R. Dennington

The extensive use of curves plotted on cross-section paper for representing the variation of one quantity with reference to one or more others, makes the explanation of the methods of constructing the curves and the statement of the advantages of their use of special interest.

Coordinate curves are those which are plotted with reference to two straight lines drawn at right angles to each other and called the coordinate axes. The horizontal axis, $X'X'$, Fig. 1, is referred to as the X axis or the axis of abscissas, while the vertical axis, $Y'Y'$, is called the Y axis or the axis of ordinates. All horizontal distances measured on the cross-section paper from the Y' axis along or parallel to the X axis are called abscissas, and all vertical distances measured from the X axis along or parallel to the Y axis are called ordinates. The point O where the axes intersect is called the origin. Abscissas measured to the right of the Y' axis are considered as having positive values, while those measured to the left of the Y axis are considered as having negative values. In a similar manner the ordinates measured above the X axis are considered as positive, while those measured below the axis are negative. In almost all engineering work the measurements are positive and therefore the curve lies in quadrant a between the axes $O'X'$ and $O'Y'$. This brings the origin of the curve at the lower left-hand corner of the curve sheet if the measurements are considered as starting from zero. In some curves the true origin does not appear on the curve sheet, because an auxiliary axis of abscissa as $O'X''$ or an auxiliary axis of ordinates $O'Y''$ has been used to reduce the length of ordinates or abscissas and to allow the use of a larger scale; that is, larger distances to represent the units in which the curve is plotted.

Choice of Scales.—In deciding upon the scale to be used for any coordinate curve it is necessary to consider the purpose for which the curve is intended. If it is desired to show up small differences, the units must be plotted to a large scale, while if there are wide differences between the values to be plotted the scales must be such that the largest value can be included on the cross-section paper. Very often it is convenient to plot several curves on one sheet and in this case two or more scales of ordinates and abscissas are

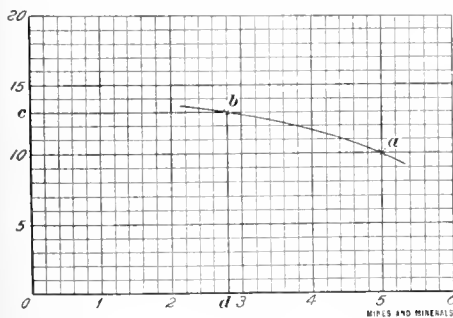

FIG. 2

used. The curves are lettered or named so that it is possible to refer to the proper scales.

Location of Points.—The position of any point on the cross-section paper is definitely determined by means of its abscissa and ordinate, since the abscissa tells the distance of the point from the Y axis and the ordinate tells its distance from the X axis. The

abscissa and ordinate of any point are known as the coordinates of the point. For example, in Fig. 2, the abscissa of the point a is equal to 5 units on the scale of abscissa and the ordinate is equal to 10 units on the scale of the ordinates. If an ordinate line is drawn in Fig. 2, at a point 5 on the scale of abscissa, this ordinate must contain all points which are 5 units distant from the Y axis. As the ordinate of the point to be located is 10 units, it is only necessary to lay off on the ordinate line a distance equal to 10 units on the scale of ordinates in order to definitely locate the point. It is also possible to determine the value of the ordinate corresponding to a given abscissa of a point b on a curve by drawing a horizontal line $b'c$ through the point and noting the value of the ordinate $O'c$ on the scale of ordinates. In this case the ordinate has a value of 13. This process may be modified if it is desired to find the value of the abscissa corresponding to a certain ordinate. In this case a vertical line $b'd$ would be drawn through the point and the value of the abscissa $O'd$ is determined by referring to the scale of abscissas at the bottom of the diagram. The value of the abscissa is shown by the diagram to be 2.8.

Application of Coordinate Curves.—The curve showing the power required to operate the water hoist of the Hampton Mine, Scranton, Pa., is shown in Fig. 3. The hoist is operated by an induction motor rated at 800 horsepower and running continuously at a speed of approximately 225 revolutions per minute. When the water is being discharged from the buckets they are held stationary for a period of 6 seconds. The time in seconds is plotted as the abscissas of the curve, while the power in kilowatts supplied to the induction motor is plotted as ordinates. After the water from a bucket has

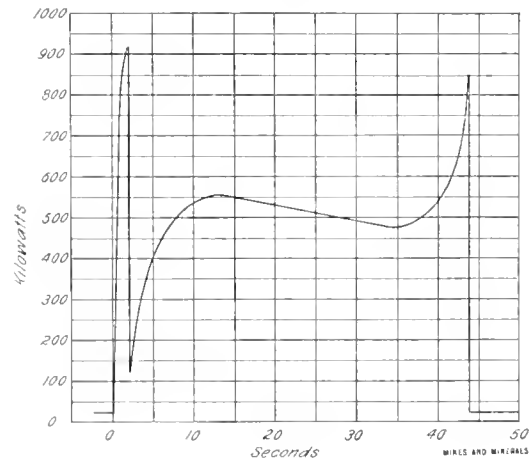

FIG. 3

been discharged the hoisting mechanism is thrown into gear. The power required by the motor increases from a minimum of about 20 kilowatts to a little more than 900 kilowatts. This momentary increase in power is necessary in order to overcome the inertia of the buckets and the hoisting mechanism. As soon as the buckets begin to move, the power required by the motor drops to a value of about 120 kilowatts, but begins to rise again immediately. The rapid increase in power after 2 seconds have elapsed is due to the buckets at the bottom of the shaft being raised out of the water, and it is also due to an increase in the speed of the moving buckets. The power required gradually increases to a maximum of 550 kilowatts and then drops to a value of 480 kilowatts. When the empty bucket gets near the bottom of the shaft and begins to enter the water, as is the case from the 35th to the 44th second, the power increases rapidly because the balancing weight of the empty bucket is removed from the hoisting cable. As soon as the loaded bucket reaches the top and becomes stationary during the discharge, the power drops to the original 20 kilowatts. The curve shows the power required at any instant during a complete cycle of operations, and by means of the curve the average power might be computed by adding the lengths of the various ordinates of the curve and dividing by the number of ordinates taken. The greater the num-

ber of ordinates included in the measurements, the more accurate would be the determination of the average power.

The flow of water through pipes may be estimated very conveniently by means of coordinate curves. A set of curves which may be used for this purpose is given in Fig. 4. In this case the values of the abscissas are given in gallons of water per minute and the ordinates are given in frictional heads in feet of water and also at the right of the curve the frictional head in pounds per square inch. The various curves have the sizes of pipes marked on the curves and the length of each pipe is assumed to be 1,000 feet. The curve shows that if the flow of water through a 6-inch pipe is 300 gallons per minute, the frictional head is equivalent to about 8.5 feet of water, or to 3.68 pounds. If the flow of water is 1,000 gallons per minute through a 10-inch pipe, the frictional head is equivalent to 7.3 feet of water, while if 1,000 gallons flows through a 12-inch pipe the frictional head is only 3 feet of water. By means of curves it is thus possible to determine the frictional head or the loss of pressure for any ordinary size of pipe.

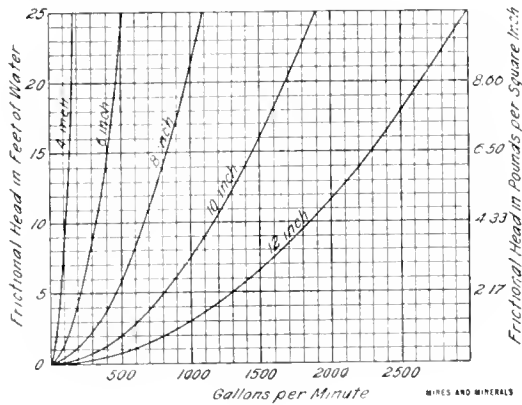

FIG. 4

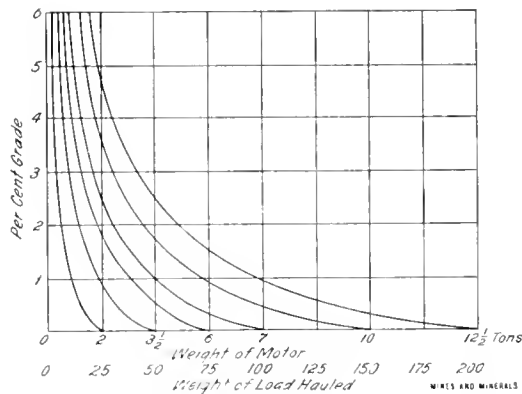

FIG. 5

The curves represented in Fig. 5 show the limitations of the weight of a load which a given mining motor can haul up a grade. For example, a motor having a weight of 7 tons can pull a load of 100 tons on level track, but will be unable to pull this weight up any grade. In order to pull a load of 100 tons up a .4-per-cent. grade it would be necessary to have a motor weighing about 10 tons. This would leave very little margin for extra friction due to bearings, and it would be much better to have a motor with a weight of 12½ tons in order to pull a 100-ton load up a grade .4 per cent. or .5 per cent. If a 7-ton motor is installed, and the maximum grade is 3 per cent., the load which the motor can haul will be found by following the curve from the abscissa marked 7 to a point where the ordinate has a value of 3. By following the vertical line from the curve to the scale of abscissas giving the weight of the load, it is found that the maximum weight is about 20 tons. A 10-ton locomotive can haul a load of 30 tons up a 3-per-cent. grade or can haul 17.5 tons up a 5-per-cent. grade. This latter value is found by tracing the curve until it intersects the horizontal line 5 on the

scale of ordinates and following the vertical line on this point to the scale of abscissa which gives the load in tons. The curves are based on a drawbar pull of 20 pounds to each ton of car load to a level track.

采 采

Kenova-Quadrangle Coal Strata

The readers of MINES AND MINERALS are indebted to Irvin Frailey, E. M., of Windber, Pa., for the Kenova quadrangle coal-rock sections given on the opposite page. The generalized sections of the Carboniferous rocks in Kentucky and West Virginia, with correlations, as determined by the West Virginia and Kentucky Geological Surveys, are connected by dotted lines. In the center is a map showing the location of the sections. Believing that this diagram will appeal to many subscribers to MINES AND MINERALS a number of extra copies, suitable for office use, have been printed and can be obtained by addressing MINES AND MINERALS, and enclosing a 2-cent stamp.

采 采

Coal Mining Notes

Pocahontas Special Map.—The "Pocahontas special map" has just been published by the United States Geological Survey as a part of the topographic map of the United States, which is being made by the Geological Survey in rectangular sections, most of which represent areas of about 200 square miles each. The area shown on the Pocahontas sheet covers operations of western Virginia and southeastern West Virginia and, as the name implies, includes the famous Pocahontas coal area. The survey of the West Virginia portion was carried on in cooperation between the Federal Geological Survey and the state of West Virginia, each paying one-half the cost of the field work. The map is published on a scale of 1 mile to 1 inch, with 50-foot-contour intervals. It gives an excellent delineation of the topography of the country—the mountains, valleys, ridges, slopes, rivers, creeks, and all other natural features—besides all the works of man. The town of Pocahontas is located in the south-central portion of the area, and the Geological Survey's bench mark at this point shows an elevation of 2,320 feet above the sea level. The map is sold by the United States Geological Survey for 5 cents a copy, or \$3 a hundred, the cost of paper and printing. Application should be made to the Director, Geological Survey, Washington, D. C.

Eight-Hour Law in Pennsylvania.—Hoisting engineers in the Lackawanna and Wyoming valleys of Pennsylvania have been granted 8-hour shifts, without decrease in wages. The D., L. & W., Susquehanna, and Lehigh Valley coal companies were the first to grant an 8-hour shift and it is predicted other companies will soon follow. It was claimed that 10 hours at the throttle of a hoisting engine was too exhausting on the men, and accidents were liable to happen, if the men did not have shorter hours of work.

Explosion in Truesdale Colliery.—An explosion of gas in the Truesdale colliery of the D. L. & W. Coal Co., February 25, caused the death of two men and considerably damaged the mine. The men were engaged in removing a brattice in order to hang a door when the gas was ignited. The force of the explosion was such that the men were thrown with violence and badly bruised. Their safety lamps were found some distance from their bodies and one was found open. Had the explosion occurred on a working day it is probable that more lives would have been lost.

Fire in No. 5 Mine Near Lehigh, Okla.—The No. 5 mine of the Western Coal and Mining Co., near Lehigh, Okla., caught fire on February 22, shortly before noon. The majority of the men at work escaped, although nine lost their lives. Owing to two driver boys giving the alarm most of the men were able to escape before the fire gained such headway as to entomb or suffocate them. Eight supposedly dead men were resuscitated. The cause of the fire is not stated, and it was reported that the mine was flooded in order to quench the fire.

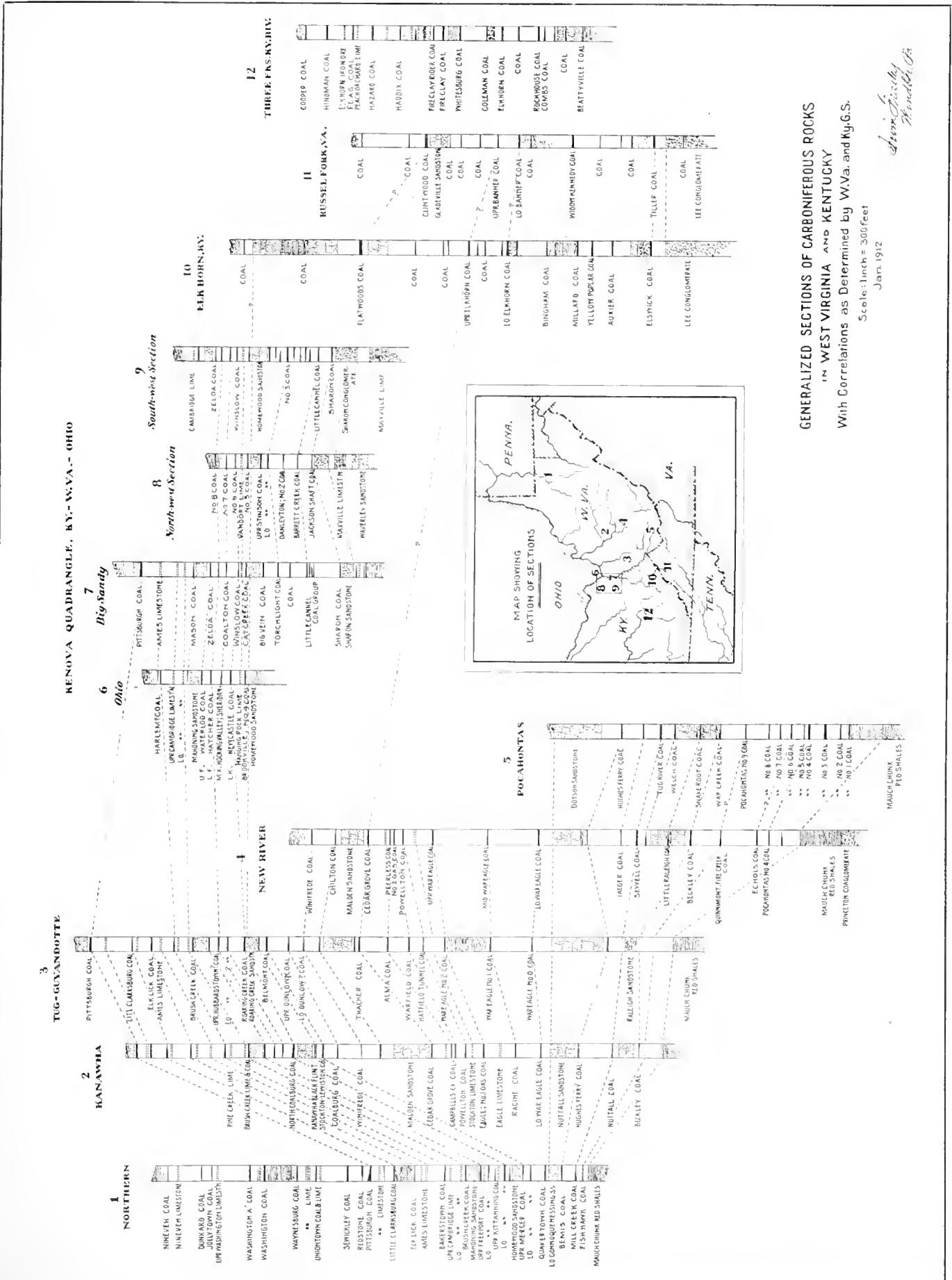

GENERALIZED SECTIONS OF CARBONIFEROUS ROCKS
 IN WEST VIRGINIA AND KENTUCKY
 With Correlations as Determined by W.Va. and Ky.G.S.

Scale: 1 inch = 300 feet
 Jan. 1912

John G. Tracy
Hendricks Co.

Lessons From Recent Mine Disasters

Precautions Against Fires and Explosions—Importance of Trained Rescue Men and Cooperation

Dr. Joseph A. Holmes, Director of the United States Bureau of Mines, addressed the Southern Appalachian Coal Operators' Association, at Knoxville, Tenn., February 13, on "Some Lessons From Recent Mine Disasters," as follows: It would be unfortunate as well as unpardonable if from the many American mine disasters of the past few years we have not learned some lessons that may help to prevent or minimize future disasters, or reduce the loss of life resulting from them. I shall endeavor to call attention to a few of these lessons that stand out most prominently.

First of all, attention may be called to the fact that we are not making satisfactory progress in reducing the loss of life in our mines; and we will never make this progress until we get away from the theory and get down to actual practice, and develop that hearty determined cooperation between the mine owner and the mine worker, which is absolutely essential to success.

Of the fatalities in coal mines for 1910, 47 per cent. were from falls of roof and coal; 16 per cent. were from mine cars; 18 per cent. were from mine explosions; 4 per cent. were from explosives; 2½ per cent. were from electricity. Of the total fatalities 90 per cent. were under ground, 10 per cent. above ground.

Lessons From Mine Fires.—Mine disasters have resulted from mine fires, gas explosions, or dust explosions, or a combination of two or all of them. The most notable recent disasters from mine fires were the Cherry disaster of November 13, 1909, where 259 men lost their lives—the fire having started from the burning of hay in the mine stable—and the Pancoast mine disaster, near Scranton, where 72 men lost their lives from a fire which appears to have started from the inflammable material at one of the underground power stations.

In neither of these two mine-fire disasters does there appear to have been any accompanying gas or dust explosion. It is evident that the men were suffocated or poisoned by the gases generated from the fire (excepting of course the few who were killed from the heat of the fire itself).

The two most important lessons taught by these two disasters were, the risks that always attend the practice, which is entirely too common, of carrying into our mines inflammable materials and keeping these materials in the mine; and, second, the inadequacy of the methods and equipment for fighting and extinguishing mine fires.

Of course we must have timber in the mine, and no economical method is now known for fire-proofing this timber. As long as we keep mules in the mines, certain materials must be carried into the mines with which to feed them; but if baled hay must be taken into the mines for feeding purposes, it can be easily and superfluently wet either by sprinkling or dipping it quickly into a tank of water, and it can be carried in closed cars. By all means the easiest way to prevent the risk of fires in mine stables is to keep these stables outside of the mine.

Lessons From Mine Explosions.—In the gas explosions of the anthracite regions, I have no evidence that the dust has in any case become involved in the explosion to the extent of increasing the force of the explosion, though I have no doubt but that much of the finer dust is partly consumed in the burning of the gas of the explosion and thereby increases the quantity of poisonous gases generated in the mine. In a number of gas explosions in the soft coal mines that I have examined, it is evident that coal dust took part in the explosion itself. In other words, there was a joint explosion of the gas and the dust.

In several mine explosions in the soft-coal region, where the larger part of the mine was wet, either from fresh, heavy sprinkling or from natural seepage, it has been evident that the explosion was limited to a small portion of the mine where the gas was present in sufficient quantity; that the dust took part only to a limited

extent in that immediate vicinity; and the explosion did not extend to other portions of the mine, because of the fact that the mine dust elsewhere was wet.

In several other mine explosions which I have examined, where the mine was thoroughly dry and dusty, and where there was no evidence to show that gas was present either before or subsequently, I have been convinced that the explosion was a dust explosion pure and simple, having been neither started nor propagated by gas.

Whether the original explosion was due to gas or to dust, or to the two combined, in many cases mine fires have resulted from the explosion, and the continuance of these mine fires has, in several recorded cases, been the cause of a second or third explosion, due to the generation of gas and the subsequent admission of air in an attempt to open up and ventilate the mine. In these second and third explosions, occurring in succession, it is more than probable that, in the soft-coal districts, both the gas and the dust have been involved each time.

Prevention of Gas Explosions.—In connection with the prevention of gas explosions, the lesson which all past experience teaches as being of first importance is to sweep the gas out of the mine by means of adequate ventilation. In connection with such a ventilating system it is important that there should be duplicate fans, so that, if in any way, one is destroyed, another is immediately available. In order to prevent the destruction of fans, they should be placed where they will not be in the line of force of any explosion in the mine.

Safety lamps and permissible or quick-flame explosives each contribute to safety; the keeping of electricity out of gaseous mines is a further wise precaution; and there are a number of other minor precautions that are important; but all will agree that the first essential is adequate ventilation. An unexpected outburst of gas from the breaking into an old gas well or from the smaller hidden reservoirs in the coal itself, each contributes a danger which it has been found difficult to provide against in many cases, but against which every precaution should be taken. In quite a number of mines the danger from gas has been reduced by an extension of the entries far in advance of ordinary working operations, and taking the gas from these advanced entries out of the mine through special exits, so as to get rid of a large portion of the gas from the coal in advance of the ordinary mining work without overloading with it the ordinary return air-currents.

Dust Explosions.—The lessons taught in the recent study of dust explosions both in connection with mine disasters and special experiments, are that the dust from practically all of the bituminous coals will explode under favorable conditions without any gas being present. They have also shown that a small gas explosion is one of the easiest ways of starting a dust explosion, which, if the mine is wet, will be a local explosion, from which many miners may escape; or if the dust is dry and abundant, will be a general explosion, extending to every part of the mine, and killing by its violence or its poisonous gases all the men in the mine.

Wet Coal Dust Will Not Explode.—One of the important lessons taught by certain recent mine explosions is that coal dust while thoroughly wet will not explode, but that with modern ventilation, and especially during cold weather, wet coal dust often becomes dry and dangerous within a few hours, and that therefore the sprinkling of coal dust "once a month" or "once a week" only gives us safer conditions for a few hours immediately following the sprinkling. Indeed sprinkling "occasionally" is often a useless and even a dangerous practice, as it does little or no good unless done thoroughly and frequently and it often tends to make us less careful in dealing with half-dry or dry coal dust in between the periods of sprinkling, and it never reaches the gob piles or other unused parts of the mine.

Wetting coal dust through the introduction of steam alone with the air-current is by all means the most effective and cheapest way of moistening the coal dust during the cold weather. This steam warms the inflowing air and saturates it with moisture, which moisture is in turn deposited on and wets the coal dust in all parts of the mine where the air penetrates. This method

continues through the winter season, the natural "sweating" process which keeps the dust wet and helps to prevent dust explosions during the summer season.

As far as possible we should keep the coal dust out of the mine. And what we cannot remove we should keep wet, either by liberal, frequent sprinkling, or turning exhaust steam into the mine, or keeping it mixed with fine soil dust, ashes, or stone dust. Permissible explosives should be used as being less likely to start a dust explosion than is black powder. Great care should be taken not to have nor to ignite local pockets of gas in a mine for fear that this might ignite the dust.

The influence of stone dust in preventing or checking coal-dust explosions is being carefully considered in France and other European countries; and in many mines the stone dust is considered more effective than water. In this country the stone dust has not passed beyond the experimental stage. But it is worthy of serious consideration and a thorough trial. Many of our mines have no steam plant near enough to be effective. And in many places the water supply is so limited that even the occasional sprinkling is out of the question. In all such cases if the use of stone dust can be made effective, the solution of this problem will be much simplified.

Good ventilation and the proper use of permissible explosives and safety lamps, and proper precautions in the use of electricity, all tend to prevent gas explosions. These precautions together with the use of steam, or water, or stone dust, tend to prevent coal-dust explosions; and the tendency of these modern precautions is to localize the explosions which they may not altogether prevent.

General and Local Mine Explosions.—A mine explosion may become a general and a disastrous explosion under either of the following conditions: (a) When explosive mine gases are allowed to accumulate there may be a general gas explosion regardless of the condition or absence of the coal dust; (b) if the mine is full of dry, inflammable coal dust which becomes ignited from a blown-out shot or any other cause, we may have a general dust explosion without there being any gas in the mine. (c) the ventilation may be sufficient to keep all the gas out of the mine except a small pocket in some remote part of the mine. This good ventilation may also dry out the coal dust throughout the mine. If now this local pocket of gas is fired by an open light it may in turn ignite the dry coal dust and cause a dust explosion that will extend through all parts of the mine. But good ventilation driving out the gas and the wetting of the coal dust or the use of the stone dust, all tend to localize the mine explosion. This especially is apt to be the case where the explosion is a local gas explosion and the coal dust does not become generally involved on account of its being wet, in a part or all of the mine.

Localizing the Explosion Increases the Chances of Rescuing Miners. In all such cases there are possibilities of men saving themselves by retreating to the remote portions of the mine and setting up barricades of brattice cloth or other material that will protect them against the poisonous gases that may result from an explosion in another part of the mine. Where the coal dust in a mine is dry and where the explosion becomes general, facts seem to indicate that nearly all of the men in the mine are killed either from the violence of the explosion or from suffocation at the time of the explosion or within a few minutes thereafter. In such cases hope of recovering the men alive several hours or several days after the explosion is exceedingly remote.

But miners are now coming to understand that efforts will be made to rescue them; and they will more and more try to protect themselves behind temporary barricades. Materials suitable for such barricades should be kept in the mines. Some day we may have a breathing apparatus so small and so cheap that every miner may have one of his own to keep in the mine, so that he can walk out through the poisonous gases whenever necessary.

Improved Rescue Methods.—Some important lessons have been learned in the last few years in connection with the rescue methods following a mine explosion. I am glad that not a man was lost in the rescue work at Briceville. And I may add that I have never

anywhere seen a more orderly and well-directed rescue work than that at Briceville, nor a better class of miners. The equipment of the Bureau of Mines and the number of men trained in the use of the helmet was entirely inadequate, and as a result the progress was unfortunately slow. But a few lives were saved; no lives were lost; the experience gained will be most helpful in future work.

At the Hanna mine, in Wyoming, a few years ago, some 40 rescuers rushed into a mine in the hope of rescuing 15 or 16 miners who had been caught in an explosion; and all of the 40 rescuers were killed. It is to be hoped that such an experience will never be repeated in the history of American rescue work. American miners of today are just as brave as those in any other country, or those of any other time, but they are learning by experience that there is nothing to be gained by rashness in mine rescue work.

Under the new system now being introduced, men wearing different types of breathing apparatus are expected to go into the mine in advance to investigate the condition of the mine, adopt the necessary steps toward ventilation, and find and extinguish smouldering mine fires; also find and rescue any persons who may still be living in the remoter portions of the mine. This modern type of rescue work is new; it is still imperfect and open to improvement. It frequently arouses criticism on the part of those who watch but do not take part in its progress; and under the circumstances this is not to be wondered at. The special breathing apparatus of today is heavy and cumbersome and the oxygen supply that it carries does not last as long as it should. Nevertheless, progress is being made, and the results of each year's experience will prove more and more satisfactory and encouraging. Recent experience in this new type of mine-rescue work at Briceville and other mine disasters has taught some important lessons. One of these is that there should be at every mine or every group of mines a number of young men trained in the use of modern breathing and rescue equipment, who are familiar with the mines in that particular district; also that the men who are trained in this work should be actual miners, men thoroughly acquainted with the mining conditions. They should be sound in health and they should be men who are not easily excited, but remain cool and thoughtful at the time of greatest risk.

There Should Be Trained Rescue Men at Every Mine or Group of Mines.—There should be at every mine or group of mines a sufficiently large number of men equipped with the breathing apparatus who can begin the rescue work in the mine as soon as the disaster occurs, expecting to be relieved or aided when other rescuers arrive.

The more training and experience a miner has in this new type of rescue work the more efficient he becomes, and the more he can accomplish within a given space of time; and the less is the risk of losing his own life. But even after a week's training such as is given by the Government mine rescue cars a miner should be prepared to take part in the rescue work following a mine disaster. Under no ordinary circumstances, should a man who has had no training previously in wearing the helmet outfit, make a trip to a remote part of the mine filled by poisonous gases; this should be done only by men who have already had such training for at least a week.

The number of men trained and supplied with modern rescue equipment should be rapidly and greatly increased in every important coal field. Within a few years more it is hoped this system will be carried forward to such an extent that in the case of such a disaster as that at Briceville, and within a few hours after a disaster, there can be assembled there from 50 to 100 men, well trained and fully equipped with special breathing apparatus, and also fairly familiar with the immediate mining district.

With a force of this kind it would be possible within a few hours to reach all the remoter portions of the mine. With the present limited number of trained men in different parts of the country, this is impossible. At no disaster previous to that at Briceville have we been able to bring together within a short time as many as a dozen experienced and well-equipped men. For a short time at Briceville, there were as many as 20 men who had some training

with helmets, but one-half of these were without actual experience and not one of them was familiar with the mining conditions in that region. A week was therefore required to accomplish results which should have been accomplished in less than 24 hours.

With a general improvement of mining conditions and the increased efforts to prevent or limit dust explosions, through sprinkling, exhaust steam, stone dust, or ashes, or otherwise, it is becoming more and more likely that explosions which may occur in spite of such precautions, will be limited to certain portions of the mine. In such cases, the chances of men escaping through other openings, or living in the mine after the explosion for several days, by putting up barricades in remote parts of the mine, will be greatly increased.

While, therefore, all will agree that the most important thing of all is to prevent mine disasters, we should also in this connection endeavor as rapidly as possible to improve our facilities for rescuing and first-aid work.

The Lesson of Cooperation.—Another lesson for us to learn is that in all efforts looking to the health and safety of the men, and the welfare of the mining industry, the active cooperation of all interested parties is necessary. Miners and mine owners may have their proper differences concerning other matters, but in everything relating to safety these other differences should give way to hearty cooperation, and they should cooperate, each with the other, to the fullest possible extent.

Meanwhile also many miners and mine officials can help this movement by sending to the Bureau of Mines a statement of their practical experience and difficulties in connection with the causes of mine accidents, mine fires, and means of preventing the same. Both operators and miners should also cooperate with the State Mine Inspectors and the Bureau of Mines in all matters pertaining to the welfare of the men and the welfare of the industry.

The existing ruinous competitive systems upon which coal mining in the United States is based at the present time should be changed, and the price paid for coal at the mines should be such as will permit and secure safe and efficient mining—mining unaccompanied by either this large loss or waste of resources, mining which can have due regard not only to the safety but also to the health and comfort of the men who toil underground and whose labor is so essential to the welfare of the nation. In my opinion, all this can be done without adding appreciably to the burden of the average American citizen, without any increase in the price of coal at the poor man's cottage, and without risk of any unreasonable restraint of trade.

The Lesson of Destructive Economic Conditions.—The economic conditions upon which the bituminous coal industry is based in this country are fundamentally bad; and if we are largely to decrease the loss of life and waste of resources we must get at and apply the remedy to the tap root of the evil, by changing these basic conditions.

采 采

The Clinkering of Coal

In an article by L. S. Marks in the *Engineering News*, this subject is taken up. After discussing the question of clinkering and the usual remedies, the investigation proceeds to discover the conditions under which the clinkering of a poor coal could be diminished. The results may be summarized as follows: The elements which cause clinkering are chiefly calcium, iron, and sulphur. The exact amounts which may be present without causing trouble are not yet known with sufficient accuracy to permit the use of such a formula as Prost's with any security. In a general sense Prost's formula is correct, that is the fusion temperature rises as the alumina increases, and falls with the increase of the other elements, but it cannot be relied upon for any particular ash. The only real cure for clinkering is low temperature combustion. If the temperatures are high, clinkering can generally be reduced by the use of steam or by adding kaolin or quartz, but these are too expensive to be commercially justifiable.

Wanted—Coal Mine Managers

By Eli T. Conner*

Coal mining, like most other industrial pursuits, has within recent years felt the need of more technically trained men for positions of responsibility.

In nearly all of the American coal fields the managements of large and small plants experience difficulty in finding capable men for the positions of fire boss, inside and outside foremen, superintendent, and managers.

In former years, there was a growing generation, sons of American, English, Welsh, Scotch, or German mining men, who were training for such positions, and many of the best managers worked their way up through the ranks and reached the highest positions, by their native ability and earnest perseverance.

This source of supply is steadily but surely becoming exhausted, largely due to the fact that from 60 to 70 per cent. of the mining population now consists of men from the central and southern countries of Europe, who so far have not generally shown the necessary qualifications for such advancement.

I am frequently asked to suggest names of men suitable for such positions, as I mention. It has before been suggested that the coal companies should systematically develop a practical school, or what might be termed "apprenticeship," for the training in all of the departments of actual coal mining, of men who have acquired a technical education. I think this plan should speedily be worked out, and put into effect, and that it could be greatly assisted by the technical and properly organized correspondence schools directing the attention of students toward the demand for energetic educated young men, who are willing to serve a sufficient length of time in minor positions to qualify for promotion.

I do not mean that these men should merely be employed on the colliery engineer corps, though such experience should be a necessary part of the development, but they should also be afforded opportunity to see and participate in every class of work connected with the development and operation of coal mines. They should diligently study and personally "take a hand" for longer or shorter periods in all of the work, bringing to bear upon each operation their superior intelligence in order to learn effective methods.

It is an acknowledged fact that underground methods, particularly with relation to the recovery of a maximum yield of the original deposit, speaking generally, have not in American mining practice improved much, if any, over those of 30 to 50 years ago.

This is a reproach that should by every possible means be overcome. One remedial measure in my opinion is more careful study and detailed supervision by trained men.

I do not wish to be understood as reflecting upon the ability of the average coal-mine managers, for as a class I think they compare favorably with similar men in other industries, but I think there is room for improvement in methods that in many instances will handsomely repay the effort and cost of "growing new managerial timber," and the suggestion I make is with this object in view. Of course, the object aimed at would be defeated unless promotion is based absolutely upon actual efficiency.

It is well known that many mining companies have to some extent put into effect the plan I mention, but I do not think they have gone far enough—according to my observation, there is often insufficient attention given to every part of the underground work. As a general thing, the mine foreman who is supreme "below the grass roots" is grievously overburdened, and consequently many methods and practices detrimental to the property and the safety of the employes are tolerated, that if the work were out in the daylight, where easily seen, would promptly be corrected.

To make the plan suggested successful, the technically trained men aspiring to positions of trust, such as mentioned, must realize that when they graduate from the best of schools of mines or correspondence schools, instead of their education being "finished," it is just beginning when they enter upon the practical course I have outlined.

*Mining Engineer, Philadelphia.

1911 Bituminous Mining Law of Pennsylvania

An Analysis of the Portions of the Law Which Will Increase the Cost of Mining

A careful and critical analysis of the 1911 Bituminous Mine Law of Pennsylvania cannot do otherwise than awaken a suspicion that the bituminous operators who sanctioned its passage did not fully realize to what extent the law would increase their cost of production. For years the producers of soft coal in Pennsylvania have suffered from keen competition with West Virginia, due to the lower mining rates in the non-union districts of the latter state, as well as the differentials in transportation rates. It is therefore all the more unfortunate that another element has crept in that will still further increase the already high cost of the Pennsylvania product.

It is entirely outside the province of this article to analyze the new law, from a standpoint of safety, nor is it the writer's intention to offer any criticisms upon the merits of the law as it was passed. It is merely intended to compare such sections of the new law as must necessarily augment cost of production with the corresponding sections of the prior law of 1893, with the double purpose of showing wherein increases in cost will be inevitable and of simultaneously impressing upon mine officials some of the many radical changes in the new law. The sections of the new law which differ sufficiently from the old law will be taken up consecutively, but will in many instances be quoted only in part. The writer has occasionally resorted to the use of italics which, of course, do not occur in the laws themselves, but it will be readily apparent to the reader that they have been used only to make comparisons more obvious.

ARTICLE III

SEC. 3. " * * * Danger signals in all mines shall be uniform, and of a *design approved by the Chief of the Department of Mines*. All danger signals shall be kept in good condition, and no defective signal shall be allowed to remain in any mine." According to the old law (Article V, Section 1), " * * * shall be properly fenced off, and cautionary notices shall be posted upon said fencing to warn persons of danger," and (Article XX, Rule 7), "He (the mine foreman) shall see that all dangerous places are properly fenced off and proper danger signal boards so hung on such fencing, that they may be plainly seen; * * *." The old law was sufficiently complied with when the word "danger" was chalked upon a piece of board or wood rail so placed as to barricade the dangerous place. It is now necessary to provide and to renew as often as their condition requires, signs not less than 24 inches long having a black background with a red center surrounding the word "danger" in white letters. These signs will not be an item of very great expense except to the owners of large mines with extensive abandoned workings.

SEC. 6. " * * * and he (the superintendent) shall also provide suitable signals to be placed on the rear end of the rear car of all trips hauled in the mines by locomotives of any kind." This is a new requirement and has been interpreted by a number of inspectors to intend that a light be kept burning on the rear car. Considerable difficulty has been experienced in attempting to provide a light which would burn continuously in the strong drafts and which would withstand the jolting. Neither safety lamps nor storage battery lamps have been entirely satisfactory.

ARTICLE IV

SEC. 1. " * * * If the mine is generating explosive gas in quantities sufficient to be detected by an approved safety lamp, the mine foreman's assistants must possess *first grade assistant mine foremen's certificates*." According to the old law (Article VI, Section 7), " * * * And in all mines where firedamp is generated the said assistant or assistants shall possess a certificate of competency as mine foreman or fire boss." It goes without saying that it will be necessary, in most cases, to pay more for the services of first grade assistant mine foremen than for fire bosses on account of the differ-

ence in the qualifications required of them, as enumerated in a later section of the new law.

SEC. 2. "He shall also see that proper cut-throughs are made in the pillars of all rooms and of all entries, * * * and that they are closed when necessary so that the ventilating current can be conducted in sufficient quantity *through the last cut-through to the face of each room and entry* by means of check doors."

The old law read (Article VI, Section 3): " * * * and the ventilation shall be conducted through said cut-throughs *into* rooms by means of check doors made of canvas or other suitable material, placed in the entries, or other suitable places, * * *." The distinction between conducting the air-current to the face of each room and into rooms is obvious.

SEC. 3. "The mine foreman or his assistant shall, at least once every week measure the air-current * * *, and also in the last cut-through in the last room * * * in each entry." This is a new provision, and while not apparently of great moment, is one of the many new provisions which collectively require the employment of assistants to mine foremen.

SEC. 5. "The mine foreman shall notify the superintendent, in writing, whenever in his opinion the mine is becoming dangerous through lack of ample ventilation at the face of entries, rooms, or other portions of the mine, caused by the undue length of entries and airways, or from any other cause, resulting in the accumulation of gas or coal dust, or both, in various portions of the mine. The superintendent shall then notify the inspector of the report of the mine foreman requesting him to come and make a personal examination, and if he finds it is becoming dangerous he shall at once direct the superintendent to have it put in safe condition, *and, if necessary, have an additional opening of ample dimensions sunk from the surface to the interior* * * *." This is a new power invested in the inspector.

A further requirement of the same section reads: "In all mines generating explosive gas in quantities sufficient to be detected by an approved safety lamp, the mine foreman shall see that, when the permanent station of the fire boss is located a mile or more from the entrance of the mine, *all abandoned, finished or unfinished workings, in the intervening distance between the permanent station and the entrance to the mine are completely shut off from the main intake or manway headings of the mine by stoppings of masonry, concrete, or some other incombustible material of sufficient thickness to keep the explosive or noxious gases from coming into contact with the intake air or with persons employed therein*."

The old law read (Article V, Section 4): "The fire boss shall at each entrance to the mine or in the main intake airway near to the main entrance, prepare a permanent station * * *." Whereas the new law provides for a distant station within the mine, the cost of the required stoppings would greatly exceed the requirements of Article V, Section 1 of the old law reading: "No accumulation of explosive gas shall be allowed to exist in the worked-out or abandoned parts of any mine when it is practicable to remove it, and the entrance or entrances to said worked-out and abandoned places shall be properly *fenced off*, and cautionary notices shall be posted upon said fencing to warn persons of danger."

SEC. 8. " * * * All shelter holes shall be made on the *same side* of the entry. *All entries* driven after the passage of this act shall have a clear space of two and one-half feet from the side of the car to the rib, *which shall be made and continued throughout on one side of the entry*, if in the judgment of the inspector the condition of the roof will permit, *and shall be kept clear of obstruction*."

The old law (Article VI, Section 4) did not require all shelter holes to be on the same side of the entry. To comply with the new law, many mines will have to dig a very considerable number of shelter holes. Article XX, Section 1, Rule 3 reads: "He shall see that the entries *at such places where road grades necessitate sprags or brakes to be applied or removed* shall have a clear level width of not less than two and one-half feet between the side of the car and the rib * * *." The cost of providing a clear and unobstructed space of two and one-half feet on one side of all entries will be very excessive in thin seams in which bottom is taken up to provide proper

entry heights for haulage as it has been the common practice in such cases to take up bottom to no greater width than was actually necessary for the cars and locomotives.

"No persons except officials or repairmen shall be permitted to travel on slopes, gravity or incline planes, while the cars thereon are in motion." This portion of the law necessitates traveling ways for men in many cases, while the old law (Article XX, Section 1, Rule 47) prohibited such travel only "when other good roads are provided for that purpose."

SEC. 9. "The mine foreman shall direct that the coal is properly mined before it is blasted. 'Properly mined' shall mean that the coal shall be undercut, center-cut, top-cut, or sheared by pick or machine, and *in any case the undercutting shall be as deep as the holes are laid.* In mines generating explosive gas in quantities sufficient to be detected by an approved safety lamp, when the coal seam is five feet six inches or more in thickness, 'properly mined' shall mean that in all entries less than ten feet wide, wherein the coal is undercut, it shall also be sheared on one side as deep as the undercutting before any holes are charged and fired, or the coal shall be blasted in sections by placing the first hole near the center of the coal seam. * * * Provided, however, That in districts in which it has been the common practice to blast coal from the solid, said practice or method may be continued, notwithstanding anything to the contrary herein contained." The old law (Article XX, Section 1, Rule 4) merely required that: "He shall direct that all miners undermine the coal *properly* before blasting * * *," leaving the interpretation of the word "properly" to the individual discretion of each and every mine foreman. While the new law in no way affects such districts in which it was customary to shoot off the solid—notably the Connellsville coke region—it has added expensive restriction to mining methods in districts in which undercutting was in vogue.

"In such portions of a dry and dusty mine where explosive gas is being generated in quantities sufficient to be detected by an approved safety lamp, the mine foreman shall direct and see that the rooms and entries are moistened by water or other efficient means as often as necessary to keep the dust in damp condition, and he shall direct and see that the dust is loaded and taken out of the mine as often as necessary." According to the old law (Article XX, Section 1, Rule 60) "In mines where coal dust has accumulated to a dangerous extent, care shall be exercised to prevent said dust from floating in the atmosphere by sprinkling it with water, or otherwise, as far as practicable." The new law requires sufficient sprinkling in dusty entries and rooms to keep the dust in damp condition at all times, while the old law merely required sufficient sprinkling to prevent the dust from floating in such parts of the mine where it had accumulated to a dangerous extent, and that meager requirement was limited by "as far as practicable." The new law requires not only continuous dampening, but also requires that the dust shall be loaded out of the mine.

SEC. 10. "He (the mine foreman) or his assistant shall *once each week* travel and examine all the air-courses and roads and all openings that give access to old workings or falls * * *." According to the old law (Article XX, Section 1, Rule 7) " * * * he shall also travel all air-courses and roads and examine all the accessible openings to old workings *as often as is necessary* to insure their safety." By requiring an examination once each week, another element is introduced toward necessitating the employment of additional assistants.

"In all mines the mine foreman shall employ a sufficient number of assistants to insure a visit to each working place, either by himself or by his assistants, *ONCE EACH DAY* while the employes are at work, and in addition thereto shall give special care, oversight, and attention to the men drawing pillars, particularly when falls are thereby being made." This requirement alone practically necessitates doubling the number of mine foremen and assistants, for the old law (Article VI, Section 6) merely required: " * * * in mines where a fire boss is not employed, the said mine foreman or his assistant shall visit and examine every working place therein at least *once every alternate day* while the miners of such place are or should

be at work." In a mine in which a fire boss was employed, it was not even necessary for the mine foreman or his assistant to visit the working places on alternate days unless *required to do so by the owner or operator.*

SEC. 12. "In any mine where it has been found impracticable to remove explosive gas from the inaccessible top of a fall, it shall be the duty of the mine foreman to make this fact known at once, in writing, to the superintendent, who shall immediately report the same to the inspector, requesting him to make a prompt personal investigation. If the superintendent and the inspector are unable to devise means to have said explosive gas removed within a reasonable time, the inspector shall direct that a bore hole or bore holes, not less than six inches in diameter, be drilled from the surface to a high point on said fall, in order to give the gas an opening to escape to the surface." The old law (Article V, Section 1) read: " * * * No accumulation of explosive gas shall be allowed to exist in the worked-out or abandoned parts of any mine when it is practicable to remove it, * * *." To adhere strictly to the new law, a mine foreman could require his company to drill bore holes in almost numberless quantities into the gob sections of most mines, as very few mines with large gob sections are devoid of large quantities of gas at the inaccessible tops of the falls.

SEC. 14. "In such portions of a mine where explosive gas is being generated in quantities sufficient to be detected by an approved safety lamp, and in which locked safety lamps are used, the mine foreman shall employ a sufficient number of competent persons, who are able to speak the English language, to act as shot-firers, whose duty shall be to charge, tamp, and fire all holes properly placed by the miners, and to refuse to charge any holes not properly placed. *No holes shall be fired by any person other than a shot-firer.* * * * In all mines in which coal is blasted from the solid, all holes shall be fired *when all the workmen are out of the mine* except the shot-firers and other persons delegated by the mine foreman to safeguard property. No shot-firer or any other person shall fire a shot in any working place or in any mine if his safety lamp can detect explosive gas at the roof. *In gaseous, dusty mines in which locked safety lamps are used, he shall fire no holes unless the entries and rooms which are dry and dusty are so thoroughly wetted as to prevent the existence of any dry dust for a distance of not less than eighty feet from the hole to be fired.* * * *." The additional expense to be borne by the operators in hiring shot-firers and wetting dust as required by the new law is so apparent that it need not be dwelt upon. The old law (Article VIII, Section 5) permitted the miners to shoot in working places where locked safety lamps were used "by the consent and in the presence of the mine foreman, his assistant or fire boss, or any competent party designated by the mine foreman for that purpose." In Article XX, Section 1, Rule 4, provision was made so that "blasting shall be done at only such hours as he (the mine foreman) shall direct," although his power to set the time was limited in Article VIII, Section 5, by the inspector's power to designate the hours of blasting in mines in which the air became too much vitiated.

來 來

Trade Notices

Removal.—The Pennsylvania Storage Battery Co. announces the removal of its offices to 221-227 North Third St., Philadelphia, Pa.

Fiftieth Anniversary of The Lunkenheimer Co.—In honor of the fiftieth anniversary of the founding of the company, The Lunkenheimer Co., of Cincinnati, Ohio, tendered their employes and families an elaborate entertainment and dance, on February 17. Over 4,000 people attended at the O. N. G. Armory. Provision was made for the entertainment of the employes' children and they were present in large numbers. Refreshments to meet the tastes of men, women, and children, were served in great abundance. In 1862, when the late Frederick Lunkenheimer laid the foundation of the company, it was but a small one-man shop. By the production of only the highest grade of engineering specialties, he

created a demand for his products that soon necessitated larger workshops and more men, and this increase in space and employees has continued until today. The Lunkenhimer Co. occupies factories, covering acres of ground, in which are employed 1,000 men, and produces the greatest variety of articles, among them being: brass, iron, semi- and cast-steel valves; water columns and gauges; ground key work, whistles, injectors and ejectors; lubricators; sliding valves, oil and grease cups, automobile and motor-boat specialties, etc. The products of the company have an international reputation, and are extensively used all over the world.

The Wash Mining Car Wheel Co. on February 1 sent out a circular letter announcing the discontinuance of their Chicago office. They state that while it was intended to merely refer to the Chicago territory, it gave a number of people the impression that they had discontinued all other offices than the home office at Barnsville. This is not correct. They still are represented in Denver, Colo., by Lindroth, Shubart & Co.; in San Francisco, by N. D. Phelps, Sheldon Building; and in Etahlan, Jalisco, Mex., by Mr. Carlos Romero.

"Scranto" Acetylene Lamps.—Two very attractive four-page folders describing in detail the "Scranto" acetylene lamps have just been issued. One circular is devoted to the lamp particularly adapted for use by miners, engineers, electricians, and repairmen, while the other one describes its advantages to hunters, campers, campers, and sportsmen. The "Scranto" lamp was invented by L. M. Evans, Mine Inspector for the Second District of Pennsylvania, and a man of many years mining experience. There is not space here to give details of construction of the lamp, but application to the Scranton Acetylene Lamp Co., Scranton, Pa., will bring the desired information.

A New "Big Stick."—A new chain graphite, especially intended for lubricating the chains of motor trucks and pleasure cars, has been put on the market by The Joseph Dixon Crucible Co., of Jersey City. It is put up in sticks, cylindrical shape, 2 in. x 8 in., encased in a neat cardboard carton and weighing about 1 lb. and each. It is made of the same material as the Dixon Bicycle Stick Graphite with which bicycle owners are familiar, and is a most convenient chain lubricant, for a bar may be carried on the car ready for use at any time. To apply, it is simply necessary to rub the bar against the sprocket side of the chain. The "big stick" makes it easy to keep automobile driving chains in first-class condition. Unlike oils and greases, it will not collect dust and dirt.

Increase of Capitalization.—The C. O. Bartlett & Snow Co., of Cleveland, Ohio, in order to keep pace with its remarkable growth, has increased its capitalization to \$500,000. About 25 years ago, Mr. C. O. Bartlett, now the company's president and treasurer, laid the foundation of this business. Its operations during the earlier years were the manufacture of oatmeal, barley pearing, and general mill machinery, but, gradually, one line after another has been added, and the business has increased to such an extent that the company is now manufacturer of all kinds of elevating and conveying machinery, complete coal rippers and coal handling machinery at the mines and docks, as well as coal and ash handling machinery and fueling scows for fueling lake vessels, mechanical dryers, both direct heat and steam dryers for rendering establishments; also crushed stone, gravel, and sand-handling and washing plants; also complete garbage disposal plants, soft mud brick machinery, and equipment for the economical handling of nearly all kinds of materials. The company has a large export business especially in Mexico, Canada, and South America. The officers of the company in addition to Mr. Bartlett are E. J. Neville, first vice-president and general manager, H. H. Bighouse, second vice-president; H. L. McKinnon, third vice-president; and I. M. Snow, secretary.

New Gas-Testing Device.—An attachment for rendering the flame of a safety lamp non-luminous, thus making the gas cap more plainly visible, is being introduced by John Davis & Son, (Derby, Ltd., Baltimore, Md.), who describe it as follows:

This attachment, the invention of Mr. Henry Briggs, consists merely of a loop of copper wire, supported on a vertical brass stalk

which extends through the glass vessel of the lamp. When it is required to make a test for gas, the loop is moved into the flame, which then immediately becomes non-luminous, allowing the gas cap to be clearly seen if fire-damp is present. The loop can be fitted to any lamp, burning any kind of oil or spirit, and using any shape of wick, and it obviates the necessity of drawing the flame down when looking for gas, hence there is no risk of losing the light. Changing from a working to a testing flame, or vice versa, is practically an instantaneous operation and the loop does not interfere with the lighting power of the lamp; nor does it curtail the height of the flame when testing. It is not delicate or fragile and the wire only oxidizes away very slowly, so that one loop lasts a long time. An ordinary Marsaut or Clanny lamp, burning three parts of oil to one of paraffin, with a flat $\frac{1}{4}$ -inch wick, and fitted with Briggs' loop, gives a cap 1 inch in height when $\frac{1}{2}$ per cent. of fire-damp is present, the flame being $\frac{1}{4}$ -inch high. A trained person can detect as little as .8 per cent. by such a lamp.

Water-Purifying Apparatus.—A contract has been awarded to the Geo. W. Lord Co. by the United States Government, for manure boiler compound for 1912, amounting to 125,000 pounds, which is a testimonial to its merits. Previously the Lord company has devoted practically its entire efforts to the stationary field, but the organization has been enlarged recently to such an extent that the company is prepared to enter new fields. Besides facilities for manufacturing and selling water-purifying chemicals, the company has a filter that is absolutely automatic in its operation, and thus is able to supply its patrons with whatever system is best adapted to the conditions existing in their individual plants. If chemicals can be supplied that will remedy the trouble without the necessity of putting in a filter, this is recommended, but where filtering apparatus is necessary it is claimed that the Lord type offers one of the most economical to install, because of its simplicity, and at the same time one of the easiest to operate, as the turning of a valve sets the whole system in operation, and no further attention on the part of the engineer is required, except to see that the chemical tank is kept supplied with chemical, and each night attend to drawing off of all impurities collected in the bottom of the filter. This is also accomplished by the mere turning of a valve. It will pay any one interested in the subject to send for one of their filter catalogs.

Cast-Steel Valves.—Superheat and high steam pressures have created a demand for valves of greater strength and durability than those made of cast iron. Anticipating the requirements, The Lunkenhimer Co., of Cincinnati, Ohio, has designed a complete line of globe, angle, cross, gate, check, non-return boiler stop, etc. valves, made of cast steel, all of which will be found in actual use, and giving satisfaction in a large number of high-pressure power plants. With the exception of the largest sizes, these valves are made of crucible steel, and not open-hearth or converter steel. Crucible steel is made and melted in closed crucibles, out of all exposure to furnace gases, and solid castings free from blow-holes are insured. This is not true of the open-hearth and converter steels, the first of which is heated by blowing hot gases over the molten metal, and the second by blowing them sometimes through the metal. Aside from forming blow holes these gases form oxides, which dissolve in the steel and thereby reduce its ductility and cause a low elastic limit. The Lunkenhimer cast-steel valves are annealed, which relieves all internal stresses and makes a fine crystalline structure, which is essential to strong steel. The company claims that these valves are the only ones which are made to meet the specifications of the American Society for Testing Materials, and that they are the only steel valves containing less than .5 per cent. of either phosphorus or sulphur. The tensile strength of Lunkenhimer cast steel is about 80,000 pounds per square inch, with a safe elastic limit and excellent elongation. For lower pressures and degrees of superheat, the company manufactures a large line of cast-iron and "puddled" semi-steel valves. Descriptive matter pertaining to these valves or any of their extensive line of engineering specialties will be sent to any one interested.

By-Product Coke Ovens in America

Economy of Saving By-Products—Increased Market for Them for Agriculture and Other Purposes

By F. E. Lucas*

So much has been said and written about the waste of natural resources in America that it seems almost useless to add to it. But the fact remains that due to this waste we have to face problems and conditions today that do not seem to have occurred to our forefathers.

In the last few decades while giant strides have been made in America in building up a magnificent steel industry, millions of dollars have been lost by making coke in beehive ovens; lost through the lower yield of coke obtained in comparison with by-product ovens and, lost in the gas that has been allowed to escape without even raising the steam necessary to run the plant.

Today steel makers are facing the problem of making pig iron and steel at a reasonable profit without raising the price so high as to kill the market.

The day of 60-per-cent. ore is about past and consequently the quantity of coke used per ton of iron made is higher. The ore from most mines costs more per ton delivered at the furnace than it did a few years ago. The demand for open-hearth steel is daily increasing, and that costs more than the Bessemer steel. Labor costs are also higher. Labor-saving devices are being added, and as labor becomes dearer and scarcer their need is more apparent.

The size of blast furnaces seems to have reached its maximum. Other causes might be mentioned to show why it costs more today to make iron than it did some years ago, but while small savings may be made through organization, labor-saving devices, etc., there does not seem to be any immediate hope of great savings in the furnace and steel departments.

The fact that a saving can be made in the coke department is just beginning to be recognized in America, although in England and Europe they have recognized it some time ago, when necessity drove them to taking advantage of every economical factor, particularly the saving of by-products. This economy has now extended to all departments; and brick, cement and slag wool are obtained from blast-furnace slag. Fertilizer is produced from basic steel slag, and ammonia, tar, and benzol from coke-oven gas. The former waste coke-oven gas is used for firing boilers, and the tar, particularly in Germany, turned into innumerable other by-products, while the waste blast-furnace gas is used in gas engines.

A few years ago one of the reasons given for building beehive ovens was that there was no market for the by-products and that the beehive ovens were much lower in first cost.

Any comparison between the cost of beehive and by-product ovens should take into consideration the large difference in yield of coke in favor of the by-product oven which will show that the difference in cost of plants per ton of output is not so great after all. Add to this the values of the ammonia, tar, and surplus fuel gas available for use around a steel plant, and the scale swings far in favor of the by-product oven.

The market for by-products, at the worst, makes it pay well to recover them in connection with the manufacture of coke, and it is growing every year.

The demand for ammonium sulphate is increasing and is bound to increase each year as the population of the country grows. The average yield of crops per acre in the United States has been decreasing and as a result many in the past few years have packed up their lares and penates and gone to the Canadian West where the virgin soil promises larger returns. But every one cannot do this, and yet the land must be

* Superintendent Coke Oven Department, Dominion Iron and Steel Co., Ltd., Sydney, N. S.

made to produce. Sulphate of ammonia is going to help in doing it.

The agricultural scientists have proved this fact and are doing the advertising. At present the production of ammonium sulphate in the United States is not sufficient for the demand, and thousands of tons are imported annually, besides all the nitrate of soda and other fertilizers.

The market for the tar is also increasing. The demand for creosote oil, one of the chief products from the tar is increasing, and it will probably not be long before all railroad ties, pit timbers, bridge timbers, etc., will be creosoted. The naphtha, benzol, and finer oils find a ready market, and as the use of internal combustion engines becomes more general the value of some of the tar products will increase.

The pitch market has fluctuated greatly, but even at its lowest price it cannot be proved that by-product ovens do not pay. Pitch is being adopted for road paving and the next few years will see a considerable development of the briquetting industry, which will create a further market for it.

Recent tests made by the United States Government have shown that for fuel purposes it pays to burn briquets rather than loose coal. In France, Belgium, and Germany, practically all the railroad locomotives are fired with briquets.

The writer recently visited the principal iron and coal centers of England and Europe mainly with the object of critically examining the various types of ovens and by-product recovery systems and briquetting plants. Last year most of the by-product oven plants in the United States were visited.

It is difficult to draw comparisons between the general practice in this country and that of England and Europe, for there is a great difference in the conditions under which they are working. In general, labor-saving machinery has not been adopted to such a large extent on the other side as in America. The reasons given for this are that labor is cheaper, and the extra fixed charges and cost of maintenance involved in the machinery just about equals the extra labor necessary to do the same work. Then when business is slack the men can be laid off but with the machinery the charges go on just the same.

Although there are some very excellent types of ovens in operation in England and Europe they do not run them to such high efficiency, so far as the production of coke is concerned, as is done in some of the plants on this side. Twenty-four hours is about the limit for the coking time, though there are ovens that could do better if they cared to force them. In both coke-oven and blast-furnace practice the general idea seems to be that it is more economical not to force matters so much as is the general practice on this side. They claim they get longer life in their ovens and furnaces and also less trouble in operating.

If the coke manufacturers in America were suddenly confronted with some of the problems that many of the plants on the other side are daily contending with, it would mean a sad upsetting until business was adjusted to the new conditions. But the conditions changed gradually and one cannot help but admire the way in which the Europeans adapted themselves to the change and overcame difficulties which at first would seem almost insurmountable. In many places in England, Belgium, and Germany the best coking coals have been exhausted, and in nearly every case it is necessary to wash the coal. In most cases, except some few places in Wales and England and some of the plants in Westphalia, it is necessary to tamp the coal before charging it in order to get a coke at all fit for metallurgical use.

Added to this, many of the furnaces are working ores running as low as 25 per cent. iron and have to calcine them before charging in the furnace. The product from the calcining plants carries only from 30 to 35 per cent. iron. Other pig-iron furnaces are working almost entirely on imported ores. There are of course a few plants more favorably situated than others that still have good ore supplies

The most striking difference between America and the older countries is in the saving of by-products, and in this we are far behind. Germany particularly has a long lead both in the quantity of by-products recovered and also in the simplicity of the apparatus used.

This is not due to their superior inventive genius but to the necessity for saving everything possible in order to make finished material at a price which would allow them to compete for the world's trade; and secondly, the fact that the laws will not permit them to pollute the air and streams with gases and sewage as in this country; and since the operators had to dispose of them by other means they made the work pay for itself by the recovery of by-products.

One of the chief reasons why Germany has such a lead over all others is due to their system of education and the facilities that are given to any young chemist of promise for research work. The chemist knows that if he discovers a new by-product that can be made a commercial success, or if he can discover a method for synthetically manufacturing some product cheaper than the natural product can be obtained, his future is assured.

There are many things on the other side which, if adopted on this side, would mean a great saving, and there are also things on this side which could well be adopted in Europe. But the difficulties which they have met and overcome will just as surely one day confront us, and with the knowledge of their failures and successes, the solution of the problems should be much easier for us.

柔 柔

Automatic Drainage

So great is the number of details incident to mining which require personal attention and supervision, that every advantage should be taken of automatic equipment. An interesting device of such a nature was worked successfully for a number of years in a Western Pennsylvania coal mine. It was a combination of an electrically driven pump and a self-starting siphon.

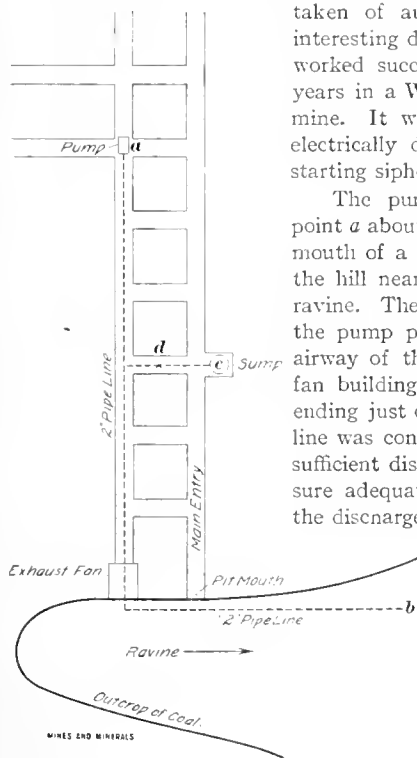

FIG. 1

In driving the main entry of the mine, a local swamp was encountered about 700 feet from the entrance to the mine, and considerable annoyance was experienced with water which accumulated in this swamp. To handle this water, a sump was dug at *c* and a 2-inch pipe line was laid from the discharge line of the pump to the sump, with a swinging check-valve at *d*, so placed that it was kept closed by the pressure of the pump.

Like many another coal mine, the quantity of electric power was none too great, as a result of which it was no unusual thing for the power lines in the mine to become sufficiently overloaded

to knock out the main circuit-breaker located in the power house, resulting, of course, in a temporary stoppage of the pump, which remained idle until a nearby trapper restarted it. In the meantime, the automatic feature of the apparatus had been in operation, for immediately upon the stopping of the pump the release of pressure in the discharge line allowed the check-valve *d* to swing open, and the line from the sump *c* to the end of the line at *b* became operative as a very efficient siphon line.

The restarting of the pump immediately closed the check-valve, thereby shutting off the siphoning from the sump, but the intermittent action of the siphon line took care of the sump in a very satisfactory manner. It may be possible for such a system to be adapted to suit existing conditions in other mines where topographic conditions are such as to admit of converting discharge lines into siphon lines.

柔 柔

An Effective Mine-Air Humidifier

In the descriptive article on the Penn-Mary mine plant, which appeared in the December, 1911, issue of *MINES AND MINERALS*, mention was made of an arrangement for humidifying air entering a mine. In a recent issue of the *Coal and Coke Operator*, Walter Proctor, E. M., states that Col. Lawrence E. Tierney, of Powhatan, W. Va., commenced experimenting along similar lines in May, 1911, at his Powhatan mine and that the experiments were eminently satisfactory.

The humidifier here described differs from Mr. Tierney's only in construction and method of heating the air going into the mine.

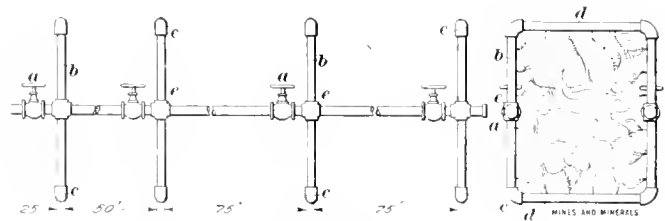

FIG. 1

Cold air must be heated to the normal temperature of the mine and humidified, otherwise it will absorb moisture from the coal, and it is probable that Mr. Frank Haas, of Fairmont, W. Va., was the first to suggest the use of steam as an air moistener and temperature raiser combined. In Fig. 1 a steam pipe, 4 inches in diameter, connects the four 4-inch diameter pipe frames *b* at distances ranging from 25 to 75 feet apart along the intake. The pipes composing the frame are perforated inside as shown at *d* in elevation so that the openings will be at right angles to the walls in order that all cold air entering the mine will pass through the escaping steam. The first frame will heat the air and cause it to absorb some moisture but not sufficient to increase the humidity to 90%, the generally desired hygrometric point, therefore a second frame is placed 50 feet beyond the first, and a third 75 feet beyond the second and a fourth 75 feet beyond the third. Each frame is connected with the main steam pipe by a throttle valve *a* because all four frames will be needed only when there is exceptionally cold dry air outside. This arrangement will permit the humidity of the air circulating in the mine to be regulated.

The temperature in coal mines should not exceed 70° F., and even then the mine atmosphere should not be saturated with moisture. Another matter of moment connected with this subject is that too much reliance placed in moisture in mine atmospheres may prove disastrous, for dust already formed will absorb little if any moisture from the atmosphere, consequently it must be removed from the entries or made innocuous. The object of humidifying mine air is to prevent its absorbing moisture from friable coals like the Pittsburgh, Pocahontas, Freeport, and the Colorado coking coals, that are easily air slacked, and rendered in a favorable condition for an explosion, if a propagating flame originates from any cause.

Mine Gas Investigations

The Results of Analyses of Gases in Anthracite and Bituminous Mines Taken Under a Variety of Conditions

This is an abstract from G. A. Burrell's paper on "The Composition of Some Mine Gases, and a Description of a Simple Methane Apparatus," which was read at the December meeting of the Coal Mining Institute of America. Mr Burrell is chemist of mine gas investigations for the Federal Bureau of Mines, and in his paper he furnishes data on combustion of methane, powder fumes, gases from fire in an anthracite mine, gases from fire in a bituminous mine, gases from a working mine, and gases from a mine 18 hours after an explosion.

From two mixtures of methane and air with an insufficient supply of air for complete combustion of the carbon, the percentage results shown in Table I were obtained after explosion.

TABLE I. INCOMPLETE COMBUSTION OF METHANE CH_4

Percentage of Methane	10.03	10.94
Carbon dioxide.....	10.16	8.35
Carbon monoxide.....	2.13	4.47
Hydrogen.....	1.39	3.66
Nitrogen.....	86.32	83.52

The most explosive proportions of methane and air are methane 9.47 per cent., air 90.53. According to these experiments, as a natural inference, carbon monoxide and hydrogen increase as methane is increased and the air supply decreased. The carbon monoxide found in afterdamp is due to incomplete combustion of gas, and in some bituminous mines, to coal dust being heated to incandescence, thus liberating the CO . Table 2 gives the gases obtained after explosives had been fired in coal mines.

TABLE 2. GASES GIVEN OFF BY EXPLOSIVES

Series Number	II		III			
	1	2	1A	2A	3B	4B
Carbon dioxide.....	16.8	9.1	1.40	.56	2.50	.30
Oxygen.....	4.3	7.5	19.31	20.22	16.91	20.61
Carbon monoxide.....	22.8	3.2	1.45	.16	1.21	.02
Methane.....	17.3	14.1	1.40	.71	4.88	.25
Hydrogen.....	8.9	4.1	.74	.06	1.06	.01
Nitrogen.....	29.9	62.0	75.74	78.29	73.44	78.51

Samples 1 and 2, series II, were obtained from crevices after blasting coal. Both black powder and permissible explosives produce noxious gases. The quantities of methane and carbon monoxide show both explosive and noxious qualities and account for the miner getting burned when he fires his powder smoke.

Samples 1 A and 3 B were crevice samples taken immediately after shots had been fired. Samples 2 A and 4 B were taken 4 minutes after the shots had been fired. In one case, .16 per cent. of carbon monoxide was found a harmful quantity. These explosives were fired under conditions which do not represent the best practice. The experiments show what has been advised for many years, that it is bad practice to proceed immediately to the face after a shot.

Black powder, which contains sufficient oxygen for the complete combustion of the carbonaceous matter present, produces when fired in coal mines, some carbon monoxide, due to reaction with the carbon of the coal dust. Some explosives, however, are themselves very deficient in oxygen.

Table 3 shows the composition of the atmosphere in an enclosed section of an anthracite mine. This section of the mine was sealed off because of a fire which existed in an adjoining section. The fire did not affect the particular area from which these samples were obtained because of a heavy intervening roof fall, consequently, the gases represent those trapped and given off normally in a stag-

nant section, except that a stopping was leaking and some air was finding its way into the interior from the ventilating current. The stopping was tightened and the rapid absorption of oxygen by the coal is shown by the third analysis. Four days later the oxygen had dropped to 3 per cent. Even so, some air was finding access. The rapid accumulation of methane is also shown, 53 per cent. on the sixth day.

TABLE 3. GASES FROM AN ENCLOSED AREA IN AN ANTHRACITE MINE

Sample	Date	CO_2	O_2	CO	CH_4	H_2
1	October 31.....	2.2	15.0	0	14.0	68.8
2	November 1.....	2.3	14.6	0	18.1	65.0
3	November 2.....	2.6	6.2	0	24.2	67.0
4	November 2.....	2.9	5.7	0	29.3	62.1
5	November 3.....	2.8	4.1	0	34.9	58.2
6	November 6.....	2.6	3.0	0	53.0	41.4

The composition of two samples of gases from an enclosed area in a bituminous mine is given in Table 4.

TABLE 4. GASES FROM AN ENCLOSED AREA IN A BITUMINOUS MINE

Sample No.	CO_2	O_2	CO	CH_4	N_2
1	1.50	.30	0	5.29	92.91
2	1.20	.30	0	5.37	93.13

A mine fire had once existed in the area and these samples were collected by means of breathing helmets 9 months after the fire had originated and prior to the reopening of the mine. The oxygen had almost entirely disappeared.

Samples Nos. 1 and 2 in Table 5 were obtained directly from a fire area, 4 and 7 hours, respectively, after the mine had been sealed off.

TABLE 5. BITUMINOUS MINE FIRE GASES

Sample No.	CO_2	O_2	CO	H_2	CH_4	N_2
1	8.07	1.69	1.58	1.37	3.39	83.90
2	9.14	1.83	1.32	1.03	3.60	83.08
3	2.93	10.34	.56	.13	.82	85.22

The fire occurred just inside the pit mouth of a bituminous drift mine. Samples were obtained by boring holes through the thin roof covering. These analyses, with others, showed that the air was not leaking to an appreciable extent and the existence of an atmosphere that could not further the progress of the fire. No. 3 analysis of this series represents the atmosphere in the same mine about 1,400 feet away from the seat of the fire. The mine was entered through another entry, and with the aid of oxygen helmets samples of gas were obtained. The party could not proceed farther because of heavy smoke. It was impossible to shut off the air because of various small openings in the outcrop.

The composition of the atmosphere in an enclosed area of an anthracite mine while a fire existed therein is shown in Table 6.

TABLE 6. ANTHRACITE MINE FIRE GASES

Sample No.	October	Time	CO_2	O_2	CO	CH_4
1	27	12:00 P. M.	3.5	8.3	1.3	11.5
2	27	12:00 P. M.	3.8	9.6	.7	13.1
3	28	9:45 A. M.	3.4	10.9	.6	10.8
4	28	4:00 P. M.	3.4	11.3	.6	10.3
5	28	4:30 P. M.	3.0	12.6	.4	9.6
6	29	11:00 A. M.	3.3	14.1	.6	9.0
7	29	3:30 P. M.	4.0	13.6	.8	12.0
8	30	10:30 A. M.	4.8	10.1	1.2	14.1
9	30	5:00 P. M.	4.0	12.2	1.0	12.2
10	31	6:30 A. M.	12.2	6.6	.4	6.6

Dams were in place and water was being forced behind the dams in an effort to flood the fire area. Samples of the atmosphere behind the dams were obtained and analyzed. The first two analyses behind the dams were obtained and analyzed. The first two

analyses show the results of the first day's sampling. The 2 days following, despite efforts to tighten the dams, leakage of air occurred to such an extent that the fire burst forth with renewed intensity. This happened when the oxygen in sample No. 6 had risen to 14.1 per cent. The air was inleaking through another dam, and some of the products of combustion were finding exit at the dam where sample No. 6 was taken. After sample No. 6 was taken the fire was again brought under temporary control, as shown by the decrease in oxygen. The carbon dioxide and carbon monoxide also rose. Then air again started to inleak and in order to avoid another outburst of fire, a carbon dioxide fire extinguisher was brought into the mine and carbon dioxide was forced behind one of the dams for 5 hours, checking the fire until new and tighter dams could be built. The rise in carbon dioxide due to this cause, is shown by sample No. 10, collected one-half hour after the use of the extinguisher had been discontinued. The new dams held water well, and excluded air, so that the fire was rapidly brought under control.

No. 8 Series.—Table 7 shows samples of normal mine air taken from different sections of a mine in the Pittsburg seam.

TABLE 7. NORMAL MINE AIR IN PITTSBURG SEAM

Sample No.	Cubic Feet of Air Per Minute	CO ₂ Per Cent.	CH ₄ Per Cent.	Cubic Feet of CH ₄ Per Minute
1	17,400	.04	.10	.17
2	21,600	.06	.04	.203
Return Face 3	63,000	.11	.75	473
4	air still	.12	1.80	
Return 5	79,800	.15	.19	152
6	21,600	.06	.10	.22
7	31,500	.13	.70	220
Face 8	air still	.11	1.35	
9	39,200	.15	.75	291
10	8,100	.09	.34	.28
11	11,400	.06	.14	.16
12	32,400	.09	.94	305
13	23,200	.05	.95	220

At the time the new Pennsylvania mining code was proposed, embracing certain features relating to the percentage of methane allowable, one of the mining companies asked the Bureau to sample the air in its mines with a view to determining just how much methane was present. Since that time the Bureau has trained a chemist for the work, installed a gas-analysis apparatus, and the company is now having daily analyses made. It can be stated that the Bureau will do this much for other mining companies if they desire closer methane determinations than the safety lamp will show. The state inspection department of Alabama, among others, is being given similar aid. The Chief Mine Inspector is installing a laboratory in his office and his men will frequently send in samples.

Column 1 in Table 8 shows the composition of gas obtained from the face of an entry 18 hours after a mine explosion and before ventilation had been restored. Column 2 is an analysis of a gas taken from the same mine in another place after ventilation had partly been restored.

TABLE 8. ANALYSIS OF GAS AFTER A MINE EXPLOSION

Composition	1	2
CO ₂	1.37	.32
O ₂	18.14	20.50
CO	.60	.04
CH ₄	1.23	.19
H ₂	.28	(below .02 per cent.)
N ₂	78.38	76.95

The seat of the explosion was supposed to have been close to where No. 1 sample was taken. A canary bird carried by an exploring party, unequipped with helmets, collapsed as it was being carried in this entry about 200 feet back from the face. The bird revived when brought back to fresh air. The sample is further interesting in that 1.23 per cent. of methane was found to be present. This particular explosion was supposed by some to have been originated by the flash of short-circuited electric wires igniting

coal dust, but the fact that considerable methane was found at the face, points to the possibility of firedamp playing some part in the catastrophe.

No. 2 sample contains .04 per cent. of carbon monoxide. Some time was spent in this section without feeling any effects from the whitedamp, although one member stated he did not feel very well. This man had, however, been traversing this and other sections of the mine for 7 or 8 hours; consequently, it is possible that he had been breathing small percentages of carbon monoxide a large part of the time. Eight men lost their lives in this explosion, and at least six of them were overcome by carbon monoxide. Some of the rescue party also experienced very narrow escapes from the after-damp. If they had provided themselves with canary birds in the beginning of the explosion work, it is probable that a large part of the distress experienced by them would have been avoided.

來 來

Catalogs Received

- ALLIS-CHALMERS Co., Milwaukee, Wis., Bulletin No. 1801, The Isbell Varner, 20 pages.
- WALTER O. AMSLER, D. Sc., Pittsburg, Pa., The Amsler Gas Producer, 36 pages.
- AMERICAN CONCENTRATOR Co., Joplin, Mo., Bulletin No. 13, N. C. Coal-Washing Machinery, 28 pages.
- BARCO BRASS AND JOINT Co., 230 N. Jefferson St., Chicago, Ill., Barco Flexible Joint, 20 pages.
- BUCKEYE ENGINE Co., Salem, Ohio, The Buckeye Engine, 48 pages; The Buckeye Four-Stroke Cycle Gas Engine, 44 pages.
- CROSS ENGINEERING Co., Carbondale, Pa., Perforated Metal and Coal Preparing Machinery, 39 pages.
- CHICAGO PNEUMATIC TOOL Co., Chicago, Ill., Catalog No. 38, Model 'D' "Little Giant" Commercial Car, 24 pages; Bulletin E-19, Universal Electric Drills Operating on Direct or Alternating Current, 8 pages; Bulletin E-20, A New Line of Electric Drills for Heavy Duty, 8 pages; Circular No. 97, Chicago Giant Rock Drills, 4 pages.
- GENERAL ELECTRIC Co., Schenectady, N. Y., Bulletin No. 4917, Direct Current Exciter Panels, 8 pages; Bulletin No. 4918, Direct Current Switchboards, 14 pages; Bulletin No. 4919, Small Plant Direct Current Switchboards, 4 pages.
- GOULDS MFG. Co., Seneca Falls, N. Y., How and Where Pumping Costs Can Be Reduced, 16 pages.
- HARBISON-WALKER REFRACTORIES Co., Pittsburg, Pa., Fire Brick for Boiler Settings, 76 pages.
- HENDRIE & BULTHOFF MFG. AND SUPPLY Co., Denver, Colo., Coal Mine Number of the H. & B. Bulletin, 48 pages.
- INGERSOLL-RAND Co., 11 Broadway, New York, N. Y., Form 4111, Type "BC" Hammer Drills, 15 pages.
- J. M. & O. R. JOHNSON, Ishpeming, Mich., Recording Machines for Mines and Elevators, 4 pages.
- LEA EQUIPMENT Co., Philadelphia, Pa., Lea High-Duty Turbine Pumps, 16 pages.
- MCKIERNAN-TERRY DRILL Co., 115 Broadway, New York, N. Y., Hammer Drills, 12 pages.
- W. H. NICHOLSON & Co., Wilkes-Barre, Pa., "The Wyoming" Automatic Eliminator, 4 pages.
- NATIONAL ELECTRIC LAMP ASSOCIATION, Cleveland, Ohio, Bulletin No. 18, Street Railway Lamps, 8 pages; Bulletin No. 19, Electric Luminous Radiators, 8 pages.
- JOHN A. ROEBLING'S SONS Co., Trenton, N. J., Wire Rope and Wire, 183 pages.
- ROBINS CONVEYING BELT Co., New York, N. Y., Bulletin No. 48, Chains, Sprockets and Elevators, 132 pages; Bulletin No. 49, Conveyor Belts, 4 pages.
- STROMBERG-CARLSON TELEPHONE MFG. Co., Rochester, N. Y., Private Telephone Systems, 20 pages; Handy Convenient Combination Phones, 16 pages.
- A. WYCKOFF, Elmira, N. Y., Cypress the Wood Eternal, Wyckoff's Improved Steam Pipe Covering, 12 pages.

Mine Stable Management

Importance of Access to Water and Open Air—Responsibility of Drivers—Methods of Accounting

By *Beverly S. Randolph**

Since in many mines the coal output is in direct proportion to the efficiency of the stable, this department frequently attains an importance second to none with which the manager has to deal. Wherever animals are used for gathering cars no amount of efficiency in the mechanical haulage on main roads will compensate for weakness in the gathering force.

The following notes on the successful reorganization of a large mine stable some years ago might be dignified with the title of an example of "scientific management" but which has always seemed to the writer like merely giving a new name to a very old subject. At the time it happened it was simply what every man hoped to accomplish when brought to a new proposition.

When the stable in question first came under the control of the writer, it averaged about 65 head of horses and mules, approximately equal numbers of each. These were quartered in frame stables, near one of the four mines in which they worked. The coal seam mined was high, so there was no limit to the size of the animals used. The horses had been purchased by a standard of 1,400 pounds, while the mules were lighter, but by careful searching of the market mules weighing 1,400 when in fair flesh were subsequently obtained.

It had been the practice to keep the animals stabled throughout the year, except when actually engaged in work in the mine. A complete change was made in this. Commodious yards with sheds were arranged and large grass lots were set aside for the use of these animals. On Sundays and idle days, except in the most inclement weather, all animals were turned out to run in the yards in winter and the grass lots in summer.

Oats and hay had been the exclusive diet, under the impression that other feeds were debilitating. While these were retained as the staple food, continuous effort was made to provide as great a variety as practicable, bran especially being used to maintain a normal condition of the bowels.

Access to water had been confined to that obtained at troughs in the mine and the stable yard. To improve this, each stall was equipped with an individual water trough. These were all placed on the same level, a small pipe from the bottom of each trough connecting with a main controlled by a valve at the end of the stable. These branch pipes and mains were so adjusted as to drain to this valve where a waste pipe with a valve was located. By this arrangement all the troughs could be filled at once by simply turning the inlet valve and could be emptied by closing this valve and opening that in the waste pipe, thus avoiding any damage from freezing.

The utility of such an arrangement cannot be appreciated by one who has not had experience with it. No animal that has been working all day, especially when perspiring freely, can drink enough at one time to satisfy his needs until the following morning, but will be found to be ravenously thirsty an hour or two after the evening meal. Sometimes these troughs were filled three or four times in an evening.

The effect of these changes was soon apparent in the improved coats and general condition of the animals. Injuries healed rapidly and showed less tendency to degenerate into fistulous condition.

Inside mine roads were cleaned and muddy places drained or filled with broken stone, thus securing less frictional resistance to the movement of cars and better footing for the animals.

A system of strict responsibility was established among the drivers. The practice had been to give preference to those drivers who were most efficient in bringing out coal. Under this practice, if the animal of an efficient driver was killed or crippled the driver was continued at work with an animal taken from a less efficient man who in turn lost his job. This was entirely changed. If an animal was killed the driver in whose charge it was at the time was

discharged, unless he could show plainly that he was not in fault, in which case he was allowed to do extra driving until there was another animal for him. If an animal was crippled, the driver was laid off until the animal was ready for work again unless it could be shown that the driver was not at fault, when he was allowed to do extra driving. This gave each driver an interest in his animal, frequently amounting to an attachment which insured good treatment.

A considerable source of loss had been due to the failure of newly purchased animals to work satisfactorily. The practice of the previous management had been to require that an animal be actually tried out in the mine before being accepted. This worked satisfactorily in the case of animals purchased in the vicinity of the mines, but could not be applied to animals purchased in carload lots from the western market. Since it was desired to use mules altogether, under the belief that they would prove more servicable, and they could only be obtained on the western market, some arrangement to meet this difficulty was called for. To this end one of the farms rented by the company was taken under direct management. Newly purchased mules were sent to this farm; nursed through any acclimation sickness; and worked under the direction of the farm foreman, a thoroughly competent horseman, until he considered them ready for the mine. Under this arrangement every animal purchased eventually worked satisfactorily in the mines. Incidentally this farm showed a continuous and satisfactory profit.

It should be mentioned that it became the practice to clip all the hair short on every animal about the first of November each year, after the winter coat had grown. The writer confesses that he was led into this against his preconceived opinion concerning its advisability. It seemed so unnatural to remove the coat which Nature had been at so much pains to provide, therefore it was tried first on a few animals the number being added to each year as the benefit became apparent, until it was eventually applied to all animals working in the mines. The reason for the good effect obtained seemed to lie in the fact that the long hair becomes wet in the mine, and on coming out into the cold air is worse than no protection, frequently freezing before it has had time to dry. The clipped animal dries out promptly and really suffers less from cold than his long-haired companion. Freshly clipped animals frequently shiver, especially if the weather turns cold immediately after they have been clipped, but Nature appears to come to the rescue with especial provision and after a few days they show no signs of feeling the cold more than the long-haired animal.

To check results, a separate stable account was kept in which all stable expenses, including the cost of new animals, was charged, and which was credited in turn with the number of days worked by the animals at an arbitrary price per day. This daily rate was fixed at an amount sufficient to insure a small profit on the account at the end of the year.

When the writer took charge of the establishment this rate, as the result of a number of years experience, was established at \$1 75 per day. The first year's operations showed a profit much higher than was desired and the rate was reduced. Further reductions followed as the result of undesirably large profits in subsequent years, until the rate reached \$1.15 per day at which point it remained stationary, indicating a saving of 60 cents per day on each day worked. Since the animals worked about 280 days per year this makes a saving of \$168 on each animal and as the number working eventually reached 150, the total amount saved per year was over \$25,000, or about one-third the original cost of maintenance.

Coincident with the decrease in the cost of maintenance is to be noted the increase in the number of mules. Under the management of the writer only mules were purchased and the horses gradually disappeared. With so many other influences at work it is impossible to determine just how far this affected the result, but so far as could be judged without definite figures this was not without effect. It is generally conceded that the mule eats less. He certainly recovers more completely after a period of exhausting work and takes better care of himself in a wreck. On more than one occasion in the presence of "epizootic diseases" all the horses were laid up while the mules were scarcely affected.

* Civil and Mining Engineer, Berkeley Springs, W. Va.

乘	Correspondence	乘
---	----------------	---

Correction

In the article on the Standardization in Coal Washing, by Geo. R. Delamater, in March number, in the first paragraph on page 462, third line, the words (refuse coal) should read (refuse float).

Position of Stoppings to Withstand Explosion

Editor Mines and Minerals:

SIR:—I recently visited a number of mines, in all of which concrete and brick, or hollow tile stoppings were employed in the breakthroughs between the intake and return headings. At some of the mines the stopping was placed midway between the two entries, in others the stopping was flush with the rib of the intake (main or haulage road) and in one case was even with the rib of the return (back heading or air-course). The average thickness of the pillar between the entries was very nearly 30 feet. The coal possessing most excellent coking qualities and its dust thus lending itself to propagating an explosion which, presumably, would originate on the intake main, or haulage entry side, the question arises as to whether there is any choice in the location of the stoppings, from the standpoint of withstanding an explosion. I.

Tests for Oil Wanted

Editor Mines and Minerals:

SIR:—The mining papers are full of articles on hackneyed subjects. Why does not some one define what constitutes good cylinder oil, car oil, and engine oil. When once defined tell how to select them without reference to the brand, but purely the quality. It is easy to get along while using an expensive oil, but many want to know how to select oils that will be suitable for the various requirements at soft coal mines and economize in cost.

Any one can write an article in general terms, but what is required is something practical and definite by which others may be guided when purchasing.

F. D. BUFFUM
Ellsworth, Pa.

[An article on "Testing Miners' Oil," by C. S. Scott, of the Consolidated Coal Co., Fairmont, W. Va., appeared in MINES AND MINERALS, July, 1911, page 764. An article on "Oils for Lubrication," by C. E. Ward, Purchasing Agent Pittsburgh Coal Co., was written for the Coal Mining Institute of America and printed in August, 1911, issue of MINES AND MINERALS.—EDITOR.]

Accidents During Second Ten Days of Month

Editor Mines and Minerals:

DEAR SIR:—I have made from the Reports of the Inspectors of Mines of Pennsylvania, a table showing the number of fatalities due to falls of coal or roof in the anthracite mines of Pennsylvania during the calendar year 1910, showing the days of the months on which the accidents occurred. An analysis of this table shows that approximately 33½ per cent. more fatalities occurred from falls of coal or roof between the 10th and 20th of the month than between the two other periods, viz., the 1st and 10th, and the 20th and 30th. Eliminating the mine fatalities that occurred on the 31st of those months having 31 days, the number for the first 10 days and the third 10 days of the month varies less than 1.5 per cent. This shows that there was probably a preventable cause for the preponderance of such accidents during the middle days of the month. Can any mine official specifically locate this cause? A similar analysis of the same class of accidents in the various bituminous coal fields of Pennsylvania for the same year, shows that 95 fatalities occurred in the first 10 days, 101 in the second 10 days, and 97 in the third 10 days. Here again the first and third periods are nearly alike and the middle period is higher, but not proportionately as much higher, as is the case in the anthracite regions.

MINE MANAGER

Capacity of Siphon

Editor Mines and Minerals:

SIR:—Below you will find a solution of the question concerning a siphon, asked by H. L. G., of Tracy City, Tenn., in January MINES AND MINERALS:

Q = quantity in gallons per second;
 h = difference between water levels (in feet);
 d = diameter of pipe (inches);
 l = length of pipe;
 f = coefficient of friction.

$$Q = .09445 d^2 \sqrt{\frac{h d}{f l \times 1.125 d}}$$

Substituting these values the equation is

$$Q = .09445 \times 3^2 \sqrt{\frac{10.66 \times 3}{.02628 \times 1550 + 1.125 \times 3}}$$

or .74974, or, say .75 gallon per second. $60 \times 60 \times .75 = 2,700$ gallons per hour.

You will note the head $h = 34.66 - 24 = 10.66$ feet, was obtained by assuming the bottom of the pond to be the water level. H. L. G. should have measured from the surface of the water, instead of the bottom of the pond. The loss due to the 90-degree curve in quantity discharged I have not determined.

Rochester, N. Y.

A. R. WENTWORTH

Legal Interpretations of Technical Terms

Editor Mines and Minerals:

SIR:—I have been much interested in reading in your February edition, your recent criticism of my literary effort, and permit me to say that in your conclusion I agree with you absolutely as to the non-scientific accuracy in many of my interpretations of mining terms. I trust, however, that it will be patent to you that my work is not a treatise upon either mineralogy, geology, or mining engineering.

You must, therefore, fully recognize that, as but an humble instrument of the law, I am forced when writing a law book to accept the published and judicial interpretation of mining and scientific terms as defined for purposes of justice by the Supreme Court of the United States and other tribunals of Federal and State Judiciary. While it is undoubtedly a pity, as you suggest, that I could not have used the scientific knowledge of some of our leading mining engineers, or geologists, still, had I done so, my work would have been absolutely valueless to either the lawyer, or the mine owner, or the mining engineer, who refer to it, not to find out the proper scientific definition of a term, but to find out what have been the decisions of our highest courts and what is their interpretation of the law of the land.

Trusting that you will agree with me in above, and with appreciation of an honest criticism, I am, most sincerely,

San Francisco, Cal.

A. H. RICKETTS

Humidifying Mine Air

Editor Mines and Minerals:

SIR:—In the February MINES AND MINERALS I noticed an article on humidifying mine air, by Samuel Dean, Delagua, Colo., and being the advocate referred to in the article, I wish to say that upon the recommendation of this office, the Colorado Fuel and Iron Co. installed radiators and steam pipes in the intake in all their coking coal mines in southern Colorado; the radiators to raise the temperature of the ingoing air and the steam pipes to furnish the necessary moisture in the form of steam.

I have visited some of these mines since the installation of the above-named devices and find the following conditions:

At the Starkville mine the main haulage way was the intake and the fan forcing, with no visible steam in the ventilating current of 39,600 cubic feet per minute. Outside temperature 26° F., humidity 100 per cent.; underground 100 feet outside of radiator 38° F., humidity 40 per cent.; 100 feet inside of radiator 61° F., humidity 14 per cent.

Fourth south parting, 56° F., humidity 100 per cent.; 4th south intake, 59° F., humidity 100 per cent.; 1,200 feet inside of 4th south, 61° F., humidity 100 per cent.

J-6, 63° F., humidity 95 per cent. At this point there are a number of burlap curtains, which are wet as often as necessary from water pipes. These curtains extend for a distance of 300 feet. At the inner end of the curtains the temperature was 63°, humidity 95 per cent. At J-5, 63° F., humidity 100 per cent. At intersection of 8th south and J-9, 71° F., humidity 90 per cent. J-5, 79° F., humidity 90 per cent. Intersection of 8th south and J-6, 70° F., humidity 100 per cent.

At the main North Primero mine the same system of humidification is carried on with practically the same results, the haulage way being the intake and the fan exhausting.

I mention this to show that it is immaterial so far as the action of the fan is concerned, so long as the haulage way is the main intake and the temperature of the ingoing air is raised sufficiently to absorb the steam and carry it in the form of vapor, thereby rendering it invisible to the eye.

In contradiction to Mr. Dean's statement, that in order to get 100 per cent. saturation all that was necessary was to install radiators and steam, I never made any such statement.

The percentage of saturation obtained will depend upon the volume of air entering the mine and its temperature, the heating surface of radiator and the amount of moisture supplied. That is, the larger the volume and the lower the outside temperature, the greater the heating surface and amount of moisture will have to be to give the same results.

The temperature of the mines not being uniform, and the lack of moisture in the surrounding strata make it very difficult to obtain a 100 per cent. saturated atmosphere.

However, I believe it can be accomplished by putting in adequate water sprays at the different places in the mine where the temperature is high and the humidity is low.

Of course, every one is entitled to his opinions and if a person believes there is no such thing as an atmosphere containing 100 per cent. humidity, I, like Bobby Burns, do not believe in "convincing a man against his will, as he is of the same opinion still."

Denver, Colo.

JAMES DALRYMPLE
State Inspector of Coal Mines

Coal Washing

Editor Mines and Minerals:

SIR:—Mr. G. R. Delamater's article on "Standardization in Coal Washing," is an able one, and I do not see that, as a whole, exceptions can be taken, but the following comments might be made:

Mr. Delamater points out the 100 per cent. efficiency of the specific gravity bath with the aid of calcium chloride and zinc chloride and regrets that the method cannot be universally adopted on account of the cost and the inability to keep the solution at the correct density. This is true, and the same can be said of sulphuric acid, which will also make almost a perfect separation, but neither is practical for general use, as the solution will weaken by wet coal coming to the jigs, so you can see that it is good only for making tests. When I say almost perfect, I have in mind that in some instances, good coal sinks and also refuse floats, and the solution cannot be made to suit these conditions without making it unfit for general use.

It might be well to mention here the proper method to bring about the desired 100 per cent. efficiency. First, the plant must be properly equipped, having machinery sufficient to carry on the work without crowding; second, great care must be taken especially at the refuse end. Very frequently in erecting a plant too much is expected of a jig, and one is installed where there should be two or three; for instance, the coarse material comes to the jigs at 70 per cent. rock, and the best that could be expected, and at the same time maintain a perfect slate end, would be to bring it down to about 45 per cent.; therefore, in order to make it marketable as domestic sizes or fit to grind down to steam sizes, it must be run through two more jigs.

In all cases where grinding is done, I would advise jiggling it first in its regular size, taking out the pure rock, allowing the coal and bone to be crushed, then rejig in the smaller sizes.

J. B. Morrow's contention can in a general way be accepted as correct, that is, that everything that floats is good coal and that which sinks is refuse, regardless of the mineralogical or ash content, as the product is marketable regardless of the fact that there may be some pieces in this product that by taking them separately would not stand the test and still would float. The same can be said of the refuse end. You will find some good coal that will sink, but in actual preparation of coal this cannot be overcome, as the bath must suit the general conditions.

So far we have considered only the coarse material coming from the bank and believe that nearly 100 per cent. efficiency can be obtained, provided it is handled in the proper way.

Now the question of the entire plant efficiency is to be considered. In taking in raw coal from the dump, the percentages of sizes in the different banks are not the same: therefore, a percentage must be assumed, which may be as follows: All sizes above buckwheat, 20 per cent.; buckwheat, 15 per cent.; rice, 18 per cent.; barley, 25 per cent.; No. 2 barley, 12 per cent.; silt, 10 per cent.; total, 100 per cent.

This raw coal is run through the washery and sized, the fine coal going to the pockets, the buckwheat and all sizes above run through the jigs for slate separation, which will be done without a loss of coal. Should it be ground down for steam sizes it is again resized and added to the fine as it comes from the bank to the loading pockets.

Should you have in mind only the efficiency of the plant or in other words be making special efforts to attain perfection, both on the good coal and on the refuse ends, much can be done in that line, but in most operations the question of cost is considered, and the foreman in charge is apt to force his plant in order to secure tonnage and thereby reduce cost, at the expense of a loss of efficiency. This has been encouraged in the early days of anthracite coal preparation, but at the present time, different views are taken and a great deal is being done to prevent waste of good coal. It must be understood that I am speaking of the possible not the actual, as I believe the plants are very scarce that are operating at 100 per cent. on the refuse end, and should there be any, I believe reports should be made in this way: The slate end being perfect and the coal product marketable, should give the desired 100 per cent. plant efficiency.

GEO. J. WETHERS,
Supt. of Washeries, D. L. & W. Co.

Editor Mines and Minerals:

SIR:—Re "Standardization of Coal Washing," by G. R. Delamater, in your March issue of MINES AND MINERALS:

In the many tests which I have made I found that a float test made with only one liquid does not give any definite information as to the quality of the coal, nor of the refuse, because it does not show the percentage of bone or bony coal, and that has nearly as much to do with quality as slate. In some very bony veins this is of more importance than slate. You can readily see this by assuming a sample of very bony coal containing a small percentage of iron in combination. The specific gravity of iron is about 5 times that of coal, but the specific gravity of what is called "slate" in coal is only about $1\frac{1}{2}$ that of coal. Such coal would show a very large percentage of "sink" although most of the "sink" would be bony coal very nearly as good as most of the bony "float."

Scranton, Pa.

ARTHUR LANGERFELD,
Designer of Coal Preparing Machinery

The water gauge or pressure required to force air through a mine varies directly as the square of volumes. If a mine is passing 100,000 cubic feet at 1-inch gauge, what pressure will be required to pass 200,000 cubic feet? From the following proportion: $(100,000)^2 : (200,000)^2 :: 1 : x$, we have $x = 4$ -inch water gauge.

Chinese Coal for United States

Facts in Regard to Natural Resources and the Development of Chinese Coal and Coke Companies

By S. S. Knabenshue*

Some time ago a Chinese mining company made a shipment of sample coal, coke, and cement to San Francisco, the total value of the shipment amounting to \$34,563, the cargo being made up as follows: Anthracite, 2,000 tons; lump, 920 tons; slack, 1,980 tons; special coke, 5 tons; cement, 10 casks.

The foregoing company sent several shipments of sample coal, coke, firebrick, tiles, cement, etc., to San Francisco and Manila last year, but this is the largest single shipment which it has made. This fact is more significant when it is considered in the light of the departure for the United States of a representative of the company, under instructions to inspect the larger towns and cities of the Pacific coast with a view to discovering a market therein for the products of his company. It means that a definite and energetic attempt is being made by the company to find an opening outside of China for its excess output, and if the attempt is successful, American coal will find a dangerous rival on the Pacific slope. This company is one of the strongest and best managed industrial concerns in China, if not the strongest. It has behind it substantial Belgian and British capitalists, and its direction is by an able foreign engineer. Up to the present it may be said to have been in a stage of preparation. It is now in a position to hold its own in the China coal market and to look abroad for other markets to supply.

The head office in China is at Tientsin and the mines and factories of the company are in what is commonly known as the Kaiping Basin, about 200 miles northeast of Tientsin, on the line of the Imperial Railways of North China. One of the mines and the factories are in the town of Tangshan, on the railway.

The resources of the company's mines are not insignificant. In 1909 the total output of the three mines was 1,361,730 tons, or nearly 600,000 tons under the estimated present possible annual output. It is probable that the company could and would increase its annual output to a figure far above 1,937,000 if it should find in the United States or elsewhere a profitable market for its excess production.

In addition to the mines of this company there are four other large mines now being operated with foreign and Chinese capital, under foreign direction and management, and by foreign methods. These are the Peking syndicate mines at Weihsien in Honan, which produced 244,380 tons of anthracite in 1909; the Lincheng mines (Belgian mines), in the northern part of Chihli, which produced in 1909, 200,000 tons of anthracite; the Pachsin mines, in Shansi, which produced 100,000 tons of anthracite; and the Ching-Ching mines, in Chihli, which probably produced in the neighborhood of 100,000 tons of anthracite. The output of the Ching-Ching mines for 1909 cannot be definitely ascertained from the agents in Tientsin. The total output of coal from these five mines, controlled by foreign interests, may be estimated, then, at about 2,000,000 tons in 1909.

In addition to these mines there are smaller anthracite deposits west and south of Peking, which are worked partly by Chinese and partly by foreign methods, and hundreds of small deposits of anthracite and bituminous coal distributed throughout Chihli, Shansi, and Honan, worked entirely by Chinese, without the aid of foreign capital or skill. The smaller mines, while too insignificant to export coal themselves, supply a certain share of the local demand.

There are, in North China, several other mining enterprises being carried on by foreigners, notably by the Germans in

Shantung and the Japanese in Manchuria. The product of the Japanese mines at Fushun has already made a considerable inroad into the market for Kyushu coal, and last year made its appearance in Tientsin and other ports on the China coast. The South Manchurian Railway, which controls these mines, is now making a strong fight for a wider market in China, and may eventually turn its attention to the United States. In both Shantung and Manchuria there is the same sprinkling of small coal deposits, being worked by the Chinese in their primitive way, as is found in this district.

With the exception of the mining company first mentioned, which may be said to have begun in the early eighties, the mining companies in this district date back scarcely a decade, some of them not so far. They are, therefore, far from having reached their maximum output. In one case the interference of the Chinese has seriously checked the mine's progress, and in other cases the mines have filled with water and become temporarily unproductive. It is safe to predict, however, that in another decade the output of coal in this district and in all North China will be twice what it is today. This will be brought about by the improvement of the at present only partially equipped foreign-controlled mines and the adoption by the Chinese in many smaller mines of foreign machinery and methods.

The greatest need, however, if any such development in the coal-mining industry is to be experienced, is a larger market for the output. This extension of market may be found partly in China and partly outside of that country. It cannot be supposed that it will be found entirely in China. Until the advent of foreigners to their shores the Chinese used little coal.

At present, even, very little coal is used as household fuel in China outside of foreign homes. Their railways, however, and their ever-increasing industrial furnaces and the coast steamers afford a considerable demand, which is bound to increase. It will not, however, increase as rapidly as the production can be increased profitably by the mine owners, if they can find a foreign market for their surplus production. It is this fact that has turned the eyes of the coal men of North China to the United States and other countries.

The mining company referred to is the oldest foreign-controlled mining company in China, and its mines have an early history under native management. When Li Hung Chang had effected his scheme for a merchant fleet under the Chinese flag and created the China Merchants' Navigation Co., he realized that he needed coal for his ships' bunkers, and the Kaiping mines being the most accessible from Tientsin, the then northern terminus of the China Merchants' line, he created a company for their development. He then realized that a railway was needed to bring the coal from the mines to the ships, and set out to build the first section of the Imperial Railways of North China—from the mines to the Haiho. Thanks to an indirect subsidy from the Government, the steamship line still flies the Chinese flag; the railway, however, had to be completed by foreign engineers and with foreign capital, and the mines were later taken over by the present Belgo-British syndicate.

This company, from the fact that it was the first in the field and, furthermore, because of the proximity of its mines to the seacoast, and its early and better means of railway transportation, was already well established in North China and on the coast when the other companies made their appearance in the market. It is partly this fact that has kept down the output and the development of other mines. They have been unable to find a ready sale for their coal. By steady plodding, however, they have succeeded in getting a considerable sale for their products, thereby cutting down the domestic sales of the older company and forcing it to look elsewhere for markets for a part of its output. This cause more than anything else has stimulated the company to look abroad.

The mines at Tangshan and Linsi produce a good grade of bituminous coal, which has been used successfully on the rail-

* U. S. Consul General, Tientsin, China.

ways of North China, on the merchant ships along the coast, and on many foreign war vessels. It has also a large sale for household and factory consumption. It is probably quite as good as the ordinary American product. Once the company has found a market in the United States or elsewhere overseas it is probable that the other mining companies will follow more or less promptly its lead and begin the exportation of their coals. I think a safe estimate of the possible export output of coal from the mines of North China, including Manchuria, at the end of 10 years would be 2,000,000 tons annually, provided, of course, the necessary markets are found.

There is no question that the output of coal, cement, fire-bricks, fireclay, tiles, etc., in North China can be increased over the maximum possible local demand to an extent which will allow them to compete freely with other products of the same nature in markets outside of China. They are being handled by progressive and able business men, and will certainly be pushed with energy, and the low cost of production in China and the cheap ocean freight rates will make it possible to lay them down at San Francisco or at Manila at prices which will allow them to compete with no small hope of success with American products.

In the early part of 1911 a Pacific coast steel corporation in the United States entered into a contract with the Ta Yeh iron mines on the Yangtze to take annually for the next 15 years 36,000 tons of pig iron and 36,000 tons of iron ore, to be transported to the United States and there turned into finished products. While this fact is widely separated from the present campaign instituted in China to force an entrance into American markets for China coal, cement, bricks, etc., the two are alike significant in demonstrating that, commercially speaking, China is moving, or is being moved, which, in the end, will amount to the same thing.

The present course of events in China points to a not far distant resumption by the Chinese of the few railway and mining concessions still held by foreign interests, and when this complete resumption has been effected the competition between Chinese products and foreign products in China and elsewhere will mean the competition between Chinese and foreigners, and not at present between foreigners in China and foreigners as elsewhere.

Forty years ago China did not have a railway or a mine worked by anything but the most primitive native methods. Today the empire is already beginning to feel the restrictions of domestic demand for its iron and coal and other products and is looking abroad for markets for the surplus production.

采 采

Flushing Appliances in Germany

In Gluckauf, 1910, Vol. XLVI, is a description of flushing appliance at the Consolidation Colliery Shaft. The chief feature of the system is the employment of wire netting, in place of the usual brattice cloth, for keeping the packing in place laterally, and allowing the water to drain through. The netting is of galvanized-iron wire, with $\frac{3}{8}$ -inch (9 millimeters) mesh. The lowermost portion of the goaf in each section is packed by hand, in order to insure partial clarification of the water on the spot. The packing dries so quickly that the wire netting, with its supporting timbers, can be removed on the following day. To protect the bends in the wrought-iron pipes from premature abrasion by the packing material, they are fitted with wrought-iron liners of suitable diameter, bent to the proper curvature, and cut into short pieces 4 to 8 inches (10 to 20 centimeters) long, each of which is wrapped in wire netting and coated with cement mortar before insertion. Worn places in the straight lengths are patched with sheet iron, lapped with wire, the entire pipe being then wrapped with thin wire netting and coated with concrete, about 2 $\frac{1}{4}$ to 2 $\frac{3}{4}$ inches (60 to 70 millimeters) thick. In point of economy, it is calculated that the actual cost of hydraulic packing is a fraction under 6 cents (23 pfennings) per ton of coal higher than that of hand pack-

ing; but when the proportion of haulage expenses, etc., chargeable to the latter system is taken into consideration, together with the saving in manual labor and the increased protection against surface subsidence, the advantage is regarded as largely in favor of hydraulic packing.

采 采

Making a Cardboard Inkstand

Frequently engineers living in camps are compelled to use ink, and frequently that ink is spilled. E. F. Woodson, of Bevier, Mo., shows how the spilling can be prevented in tents on windy days or when inclined boards are converted into writing desks. The stand, which is easily made, can be tacked down to prevent the ink bottle slipping or being knocked over.

Believing that many of the readers of MINES AND MINERALS would appreciate this device, Mr. Woodson has taken the trouble

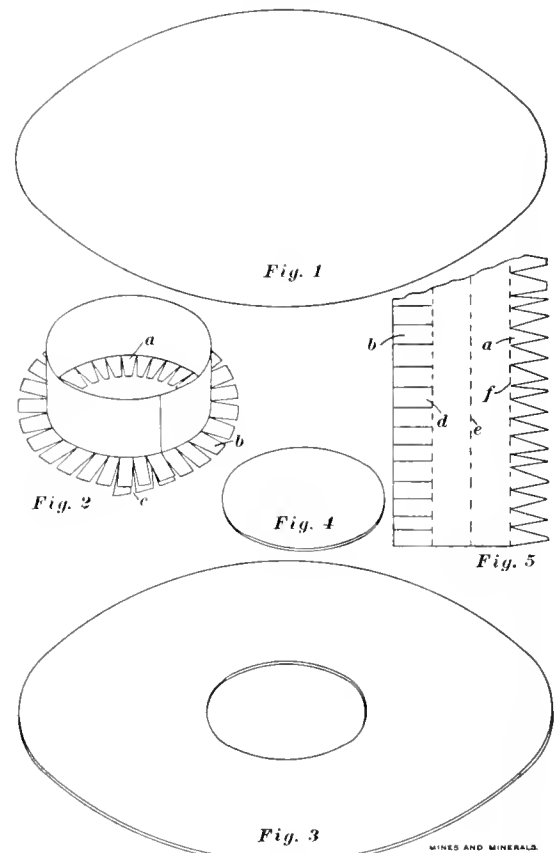

to draw plans for making it and gives the following directions for setting it up.

The illustration nearly explains itself. The first four figures show the parts relative to the stand after completion.

Cut Fig. 1, from heavy paper and Fig. 3 from cardboard, having the center slightly larger than the bottle for which the stand is being made. Trim this center to the size of the bottle as represented in Fig. 4.

Cut Fig. 5 from heavy paper, penciling lines as indicated by the dotted lines, *d*, *e*, and *f*. Cut flaps as represented by *a* and *b*, in Figs. 4 and 5, respectively.

First bend along line *e* for a complete turn of 360 degrees, then bend flaps *a* and *b* along lines *f* and *d*, respectively, 90 degrees and in opposite directions.

Cut Fig. 5, $\frac{1}{2}$ inch longer than the perimeter of the bottle, the joint being made by inserting one end inside the other as represented at *c*, Fig. 2.

Insert Fig. 2 in hole of Fig. 3, glue flaps *a* and *b*, then paste Fig. 1 on bottom. Paste Fig. 4 inside Fig. 2, thus completing the inkstand.

Big Blast at Steins, N. Mex.

The Explosion of 77,600 lbs. of Explosive in One Blast, Moving 237,000 Yards of Material

One of the largest blasts ever attempted was fired in the ballast quarry of the Southern Pacific Railroad near Steins, N. Mex. Larger quantities of explosives have been detonated before at one time, but these very large blasts are generally made necessary by some unusual conditions and rarely give perfectly satisfactory results. In this instance, however, each ounce of explosive appears

angle of 45 degrees, it appeared advisable that a pit or winze be sunk at the end of each cross-cut to hold the powder charge, and to avoid as far as possible leaving spurs of rock jutting above the level of the quarry floor after the blast. These pits, *a* to *p*, were sunk to a depth of 4 feet; the tunnels all being 6 ft. \times 5 ft., the end of each cross-cut then was 10 ft. \times 5 ft. Making these pits occupied 4 days time working day and night. The large size of these tunnels was most objectionable, because it concentrated the charges and required too much tamping; therefore, in future operations they will be reduced to 5 ft. \times 3 ft. in area. The next series of tunnels driven will have but one portal instead of four. This will be more effective, will require less powder, and will afford less chance for the escape of gases, besides requiring less tamping. This tunnel, when blasted, is expected to furnish from 7 to 8 cubic yards of broken stone per pound of powder, as there is 250 feet overburden.

All the labor in this vicinity is Mexican, and 60 men were detailed to assist in loading the powder during the day, 50 men being detailed to load powder at night. These men were searched and all matches, tobacco, and cigarette papers confiscated during the loading and until 2 feet of muck covered each charge of powder. Six of the most intelligent men from each detail were selected, and these men were deprived of their shoes, sacking being substituted. Two pits were loaded at one time, three men being stationed in each pit to receive the powder, dump it out of the boxes, and tread on it. The pits in each of the back cross-cuts were primed in the center of the charge with 200 pounds 60-per-cent. Hercules dynamite, and again on top of each charge with 150 pounds of the same explosive; a Victor 30-foot electric fuse was placed in each primer, the wires being attached to the back wall of each pit and brought up and out along the roof of each cross-cut to the main tunnel, where they were connected to leading wires and thence along the roof to the front cross-cuts, where other connections were made, and thence along the roof of main tunnels to portals. The dynamite primers were left in the cases as received from the factory. The charge of Judson powder R. R. P. in the back cross-cuts varied from 6,000 pounds to 6,500 pounds in each pit. The charges of Judson powder in the pits in the front cross-cuts varied from 2,250 pounds to 3,250 pounds, according to nature of the ground. The primer placed in the center of each of these charges consisted of 150 to 200 pounds of 60-per-cent. Hercules dynamite. One 30-foot Victor electric fuse was used in each primer. Sixteen charges of powder contained 24 distinct primers—1,350 pounds of 60-per-cent. Hercules dynamite being used in primers and 73,250 pounds of Judson powder, or a total charge of 77,600 pounds. Loading the powder and covering each charge with 2 feet of tamping occupied 2 days and 2 nights, lanterns being used at night in the tunnels with a man in charge of each lantern used. All cross-cuts were then filled and tamped to the intersection of the main tunnel, together with 10 feet of the main tunnels, with fine dirt. The main tunnels were filled with old railroad ties laid lengthwise in courses with dirt tamped between. The main tunnels being completely filled to the portals. Tamping occupied 3 days, working night and

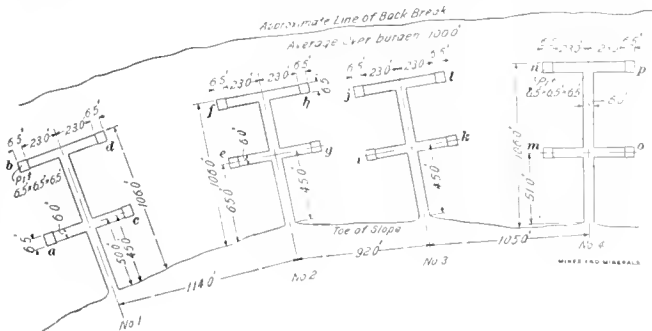

FIG. 1. PLAN OF TUNNELS FOR BLAST

to have exerted its maximum energy at precisely the proper instant and in the desired direction, resulting in a record quantity of material blasted per pound of explosive used.

The loading, connecting up, and firing of this blast was conducted by A. H. Crane, of the DuPont Powder Co., the blast having been conceived, work laid out, and excavating done under the supervision of W. H. Whalen, division superintendent; J. D. Matthews, division engineer; and Samuel Mustain, quarry superintendent, of the Southern Pacific Railroad Co.

The plant at the quarry consisted of two Gates rock crushers, power plant, compressor plant, etc., all valued at something over \$30,000, and this plant was situated directly in line with the contemplated blast, and 350 feet distant therefrom, making it a somewhat hazardous undertaking to obtain good results from the blast and at the same time leave the plant uninjured.

The breast formed an arc of a circle, as shown in Fig. 1, pierced by four tunnels each 106 feet long, each tunnel was cross-cut 45 feet back from the breast and cross-cut again at the back, each cross-cut extending 25 feet to 30 feet on either side of the main tunnels. The extreme distance between portals of tunnel No. 1 and tunnel No. 4 was 311 feet. At the front cross-cuts, the distance between the ends of west cross-cut of tunnel No. 1 and east cross-cut of tunnel No. 4 was 400 feet. These tunnels were not parallel, but diverged until at the back the distance between the end of west cross-cut of tunnel No. 1 and of east cross-cut of tunnel No. 4 was 450 feet. Owing to the dip of the ground being inward at an



BEFORE THE BLAST



AFTER THE BLAST

day, as all tamping was carried in on the men's backs. Connecting wire was used for connecting the portals of main tunnels, and a double length—1,200 feet—of No. 10 insulated copper wire was used as leading wire. All connections were tested with a galvanometer during tamping once each hour, day and night, and two breaks were detected and remedied before being completely buried. A No. 4 three-post blasting machine was used, two posts only of which were used. The result of the blast was to move the toe out on the quarry floor 150 feet, and break as computed 237,037 cubic yards. The interested officers of the Southern Pacific were delighted with results, as they expected but 80,000 cubic yards.

One stone was thrown, cutting a large elevator belt. Repairs to this belt occupied three men 2 hours. As the rock-crushing plant was entirely shut down owing to lack of material, no actual running time was lost by the accident. The material blasted is a tough volcanic rock with some granite. Many huge boulders were thrown out that required bulldozing, but this was expected. It is estimated that this blast would furnish rock ballast for about 100 miles of track.

The charge used in each pit is given, as well as the primer. The high cost per yard of broken stone, \$2.21 (it should not have exceeded \$1.50 in New Mexico), was due to making the tunnels of large area, which, of course, required extra drilling, explosives, mucking, and transporting of material, also increased cost in tamping. While in some cases large blasts are desirable, their economy, compared with outside quarry work, is debatable.

Pit	Charge	
	Judson R. R. P. Pounds	6-Per-Cent. Dyn. Pounds
A	3,000	200
B	6,000	350
C	2,250	150
D	6,000	350
E	3,250	200
F	6,000	350
G	2,500	200
H	6,500	350
I	3,000	200
J	6,500	350
K	2,500	200
L	6,500	350
M	3,000	200
N	6,500	350
O	3,250	200
P	6,500	350
Total	73,250	4,350

來來

Book Review

UNITED STATES GEOLOGICAL SURVEY PUBLICATIONS, Washington, D. C. Bulletin No. 470, Contributions to Economic Geology, 1910, Part I, Metals and Nonmetals Except Fuels, by C. W. Hayes and Waldemar Lindgren; Bulletin No. 471-A, Advance Chapter From Contributions to Economic Geology, 1910, Part II, Mineral Fuels, Petroleum and Natural Gas, by M. J. Munn, C. H. Wegemann, E. G. Woodruff, and Robert Anderson; Bulletin No. 504, The Sitka Mining District, Alaska, by Adolph Knopf; Bulletin No. 511, Alunite, A Newly-Discovered Deposit Near Marysvale, Utah, by B. S. Butler and I. S. Gale; Bulletin No. 512, Potash-Bearing Rocks of the Leucite Hills, Sweetwater County, Wyo., by Alfred R. Schultz and Whitman Cross; Gold, Silver, Copper, Lead, and Zinc in the Western States and Territories in 1910, by A. H. Brooks, C. N. Gerry, V. C. Heikes, C. W. Henderson, H. D. McCaskey, and C. G. Yale; The Production of Tungsten, Nickel, Cobalt, Vanadium, Titanium, Molybdenum, Uranium, Tantalum, and Tin in 1910, by Frank L. Hess; The Production of Gold and Silver in 1910, by H. D. McCaskey; The Production of Antimony, Arsenic, Bismuth, and Selenium in 1910, by Frank L. Hess; Summary of the Mineral Production of the United States in 1910, by W. T. Thom. Water-Supply Paper No. 287, Surface Water Supply of the United States in 1910, Part VII, Lower Mississippi Basin, by W. B. Freeman and J. G. Mathers. Report of the Secretary of the Interior for the Fiscal Year Ended June 30, 1911. Mineral Resources of the United States, Part I, Metals, 1910.

UNITED STATES DEPARTMENT OF AGRICULTURE, Washington, D. C., Bulletin No. 100, The Crater National Forest: Its Resources and Their Conservation, by Findley Burns.

DEPARTMENT OF COMMERCE AND LABOR, BUREAU OF THE CENSUS, E. Dana Durand, Director, Washington, D. C., Forest Products, No. 1, Pulp-Wood Consumption, 1910; Forest Products, No. 5, Veneers, 1910; Forest Products, No. 7, Wood Distillation, 1910.

DEPARTMENT OF COLONIZATION, MINES AND FISHERIES, MINES BRANCH, Quebec, Canada. Report on the Geology and Mineral Resources of the Chibougamau Region, Quebec, by the Chibougamau Mining Commission; Geologie du Canton de Fabre Comte de Pontiac, by Robert Harvie, M. Sc.

ANNUAL REPORT OF THE DEPARTMENT OF PUBLIC WORKS OF THE PROVINCE OF ALBERTA, 1910, Edmonton, Canada.

ANNUAL REPORT OF THE STATE MINE INSPECTOR OF SOUTH DAKOTA FOR 1911, Lead, S. Dak.

WASHINGTON GEOLOGICAL SURVEY, Henry Landes, State Geologist, Seattle, Wash. Bulletin No. 5, Part I, Geology and Ore Deposits of the Myers Creek Mining District; Part II, Geology and Ore Deposits of the Oroville-Nighthawk Mining District, by Joseph B. Umpleby.

ANNUAL REPORT OF THE SECRETARY OF INTERNAL AFFAIRS, COMMONWEALTH OF PENNSYLVANIA, Harrisburg, Pa. Part III, Thirty-Eighth Report of the Bureau of Industrial Statistics.

MICHIGAN GEOLOGICAL AND BIOLOGICAL SURVEY, Lansing, Mich. Publication 4, Biological Series 2, A Biological Survey of the Sand Dune Region on the South Shore of Saginaw Bay, Mich.; Publication 5, Geological Series 3, The Late Glacial and Post Glacial Uplift of the Michigan Basin, Earthquakes in Michigan, by Wm. Herbert Hobbs.

GEOLOGICAL SURVEY OF GEORGIA, S. W. MacCallie, State Geologist, Atlanta, Ga. Bulletin No. 26, Preliminary Report on the Geology of the Coastal Plain of Georgia.

THIRTIETH ANNUAL COAL REPORT OF ILLINOIS STATE MINING BOARD, 1911, Springfield, Ill.

THE JOURNAL OF THE IRON AND STEEL INSTITUTE, 1911, No. 11, Vol. LXXXIV, 28 Victoria Street, London, S. W.

BULLETIN NO. 8 OF THE GEOLOGICAL SURVEY OF OKLAHOMA, by L. C. Snider. This bulletin is a preliminary report on the road materials and road conditions of Oklahoma. It is divided into seven chapters treating of the following subjects: History of Road Building and Advantages of Good Roads; Road Materials and Their Properties; Construction and Maintenance of Earth, Sand, and Sand-Clay Roads; Paved Roads and Streets; Road Laws and Road Administration; Road Materials of Oklahoma; Road Materials by Counties. The bulletin contains 44 half-tones and three maps. Under the heading Asphalt and Bitumens we find that the asphalts of Oklahoma occur pure, as gilsonite or grahamite, and also as impregnations of sandstone, limestone, and shale. The asphalt impregnating the sandstones and limestones varies in nature in different deposits, some of it being of a hard pitch-like consistency and some of it being soft and oily. Very successful pavements have been laid by combining two or three natural rock asphalts; that is, a lime asphalt, a sand asphalt containing a soft pitch, and a sand asphalt containing a hard pitch. This combination furnishes all the necessary ingredients for the asphalt pavement surface; that is, the mineral aggregate, sand and limestone, the hard pitch, and the soft or heavy oil.

THE SOUTH WALES COAL ANNUAL FOR 1912, published by the Business Statistics Co., Ltd., 12 James St., Cardiff, comprises data on steam, bituminous and anthracite coal, coke, and patent fuel. It gives wages, prices, freights, exports, docking facilities, railways, and general statistics. The price of the book is 7s. 6d., net.

DREDGES AND DREDGING, by Charles Prelini, contains 274 8vo pages with index and illustrations. The book is printed by the D. Van Nostrand Co., 23 Murray St., New York, N. Y., and sells for \$3. There are 29 chapters, all of which have practical bearing on the subject of Dredging. In the preface the author says: "It is a singular fact that nearly every man feels that he is competent to carry on a job of earth or rock excavation, yet there is nothing more difficult than to do such work economically. Man since prehistoric times has been digging into mother earth, yet there is always

something to learn regarding excavation work. In this treatise only one class of excavation is touched upon, namely, dredging." Among the topics treated are: Soundings and Hydraulic Surveys, Excavation of Sub-Aqueous Rocks, Hints on Selecting Dredges for Various Kinds of Work, Classification and Capacities of Dredges, Sea-Going Dredges, Semi-Sea-Going Dredges, Universal Dredges, Stirring Dredges, Pneumatic Dredges, Dipper Dredges, Grab Dredges, Clamshell Dredges, Transportation of Debris, Dredges for Metals, Dry Land Dredging, and Cost of Operating Dredges. That part of the book which relates to dredging for gold, Chapter XXV, contains 16 pages. The book is more suited to industrial and deep-sea dredging than to gold dredging, and without doubt will be extremely useful to those engaged in river and harbor improvements, canal dredging, etc.

BUREAU OF MINES, Washington, D. C., Bulletin No. 6, Coals Available for the Manufacture of Illuminating Gas, by A. H. White and Perry Barker, compiled and revised by Herbert M. Wilson; Bulletin No. 16, The Uses of Peat for Fuel and Other Purposes, by Charles A. Davis.

DEPARTMENT OF MINES, Ottawa, Canada, Mines Branch, Eugene Haanel, Ph. D., Director, A General Summary of the Mineral Production of Canada During the Calendar Year 1910, by John McLeish, B. A.; The Production of Iron and Steel in Canada During the Calendar Year 1910, John McLeish, B. A.; The Production of Coal and Coke in Canada During the Calendar Year 1910, by John McLeish, B. A.; The Production of Cement, Lime, Clay Products, Stone, and Other Structural Material in Canada During the Calendar Year 1910, by John McLeish, B. A.

GEOLOGY AND MINERAL RESOURCES OF A PORTION OF FREMONT COUNTY, WYO., Bulletin No. 2, Series B, C. E. Jamison, State Geologist, Cheyenne, Wyo.

UNIVERSITY OF ILLINOIS, Urbana, Ill., Bulletin No. 50, Tests of a Suction Gas Producer, by C. M. Garland and A. P. Kriatz.

REPORT OF THE MINING DEPARTMENT, MINERAL RESOURCES OF TENNESSEE, 1910, R. A. Shifflett, Chief Mine Inspector, Nashville, Tenn.

WATER-SUPPLY COMMISSION, Harrisburg, Pa., Annual Report of the Water-Supply Commission of Pennsylvania for 1909.

VERSLAG VAN DE ALGEMENE BESTUURDER VAN SPOORWEGEN EN HAVENS, DE UNIE VAN ZUID-AFRIKA, Over Het Jaar Geëindigd 31 Desember 1910, Pretoria, South Africa.

REPORT OF THE LIBRARIAN OF CONGRESS for the Fiscal Year Ending June 30, 1911, Washington, D. C.

Personal

C. C. Owens has recently been placed in charge of the Detroit district sales office of the Westinghouse Electric Mfg. Co., with the title of district manager. For the last 8 years he has been connected with the New York sales office, having had charge of the industrial and power division for the two years previous to his transfer to Detroit.

One of the gold medals of the Institution of Mining and Metallurgy, London, was awarded to E. P. Mathewson, general manager of the Anaconda Copper Co., Butte, Mont., in recognition of his eminent services in the advancement of metallurgy generally and especially in regard to copper.

A gold medal was awarded to Walter McDermott by the Institution of Mining and Metallurgy, London, in recognition of his services in the equipment of the Bessemer Laboratory of the Royal School of Mines, etc.

Robert A. Quinn, general manager of the Susquehanna Coal Co., has been appointed on the new board of examiners that will pass on the qualifications of applicants for anthracite mine inspectors in the districts included in Luzerne County, Pa.

The gold medal awarded by the Institution of Mining and Metallurgy to its members in the South African gold fields, goes to Walford R. Dowling, for his paper on "The Amalgamation of Gold in Banket Ore."

Prof. H. M. Parks, head of the school of mines at the Oregon Agricultural College, was appointed by Governor West to represent Oregon at the Northwestern Mining Congress, at Spokane.

John W. Berry, mining engineer, West Pittston, Pa., has been appointed examiner of applicants for mine inspectorships in Luzerne County, Pa., anthracite district.

The Institution of Mining and Metallurgy has awarded a premium of 40 guineas to Mr. A. M. Finlayson for his paper on "Secondary Enrichment in the Copper Deposits of Huelva, Spain."

J. R. Sharp has been appointed superintendent of the mines of the Consolidated Indiana Coal Co., in Sullivan County, Ind., with headquarters at Hynera, Ind.

William Gates, of Spokane, known all over the Northwest and Alaska as "Swiftwater Bill," has organized a company with a capitalization of \$5,000,000 to develop his mining concessions in Peru. The corporation is known as the Inambar-Huari-Huari Pachani Mining Co. Alaskan and western Washington capital is interested in the project.

Charles H. Repath and A. G. McGregor, with headquarters at Douglas, Ariz., announce that they have formed a copartnership for the purpose of conducting an engineering business, making a specialty of the mechanical and electrical engineering of metallurgical and mining plants.

H. Kenyon Burch, mechanical and metallurgical engineer, has opened an office in the Union Oil Building, Los Angeles, Cal. His specialties are concentration of ores and economic handling of materials.

Francis S. Peabody, president of the Peabody Coal Co., of Chicago, Ill., delivered an address to the students in engineering at the University of Illinois on "The Operation of Coal Mines from a Commercial Standpoint."

Eugene B. Wilson, of Scranton, Pa., delivered an address February 21 to the Mining Engineering Society of Yale University on "The Commercial Preparation of Anthracite."

G. W. Traer and son, of Danville, Ill., are associated in the Traer Coal Co., just commencing operations near Danville.

采采

Wilkes-Barre Mining Institute Banquet

The annual banquet of the Wilkes-Barre District Mining Institute was held in Irem Temple, Wilkes-Barre, on March 5. Over 1,400 members of the association were present. More than 2,400 tickets were sold, and a large number of them had to be recalled owing to the impossibility of obtaining a building large enough to accommodate such an assemblage at dinner. Both dining halls of the temple were crowded to their utmost capacity.

Mr. H. G. Davis, president, stated among other things that the membership of the institute had increased from 826 to 1,686 in 1 year. Forty-two students in the mining school passed the state examination for mine foreman and assistant mine foreman. Mr. Davis admonished them not to stop but to continue their studies further until they had made themselves absolute masters of mining. He admonished them to persevere or success would not come to them; never to be discouraged at what they could not understand tonight, for tomorrow it would be clear. Not to imagine that because they were not making rapid progress they were not advancing. The very difficulty upon which they were at work might be all that stands between them and an easy grasp of the many succeeding problems. Also they should remember that the solidity of character is not attained by doing great deeds alone, but by doing common duties promptly and faithfully, and that any mine worker can become an honored man by deserving the esteem and confidence of his fellow workers and superiors; for bad as the world is, virtue and efficiency are still powerful in winning the favor of men.

Superintendent T. H. Williams, of the Kingston Coal Co., gave an encouraging address, and General C. Bow Dougherty advocated the adoption of vocational schools as authorized under the new school code. During the evening the Kingston Coal Co.'s double male quartet rendered several selections.

Spiral for Raising Rope to Knuckle

A Device for Automatically Raising the Rope, Thus Avoiding Danger and Expense

By A. A. Steel*

At a great many slope tipples, it is necessary after the empty trip has started down, for some man to raise the hoisting rope up to the knuckle sheave by means of an iron hook. This requires considerable strength and dexterity and is dangerous. Moreover it takes the time of the coupler, and therefore he cannot hold the safety derailing switch in position to let the trip down the slope. Consequently such mines do not have the derailing switch.

At a good many modern tipples, the rope is carried to the knuckle sheave by some sort of carriage spanning the track for the empties, or running between the tracks. It is rather difficult to get these to work automatically and they generally require as much of the coupler's time as the iron hook. At the slope of the Bolen Darnall Coal Co., at Hartford, Ark., a spiral is arranged to raise the rope most of the way up. This has suggested the possibility of arranging a spiral to do all the work.

For best results, it is necessary to place bends in both tracks as shown in Fig. 1. In the loaded track, this is necessary to allow the knuckle sheave to be placed between the loaded and empty track. This presents little difficulty unless the slope of the tippie is very steep, in which case the bend must be sharp to throw the trip over after the first car has raised the rope off the sheave. It has an advantage for handling a loaded trip while some loaded cars are still standing on the tippie. The bend in the other track is only needed in case there is considerable difference in elevation and not room enough for the spiral between the knuckle sheave and the empty track.

The correct design of the spiral is also a little troublesome, and the method is given below. With a correctly designed spiral, the coupler has nothing to do with the rope except to attach it to the prepared empty trip. He can then release the stop and send the trip down the mine while he holds the safety switch closed.

Fig. 2 shows a screw made of a 1-inch square iron rod riveted spirally around an 8-inch steam pipe. The detail shows a possible method of construction. The pipe is fastened by riveted arms to a 2-inch square shaft turned at the ends. For simplicity in designing the bearings, the spiral should be attached to a timber parallel to its axis as shown. The support of this timber depends upon the general design of the tippie. The lower bearing is a simple thrust bearing but the upper one must carry a heavy wing to guide

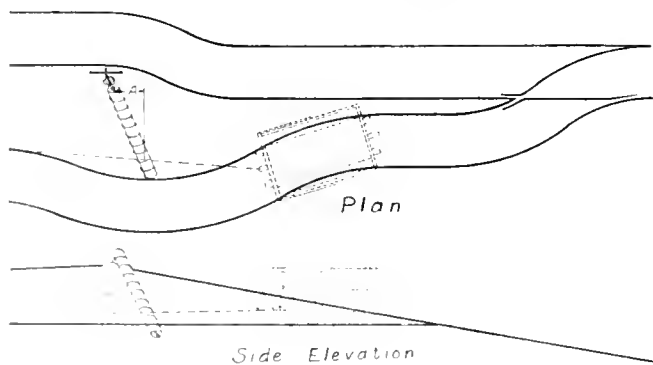

FIG. 1

the rope from the highest point of the pipe to the knuckle sheave. In order that the rope may bear equally upon the pipe and the spiral, the horizontal distance between the ends of the pipe at right angles to the center line of the tippie should equal the vertical distance.

* Professor of Mining, University of Arkansas, Fayetteville.

For best results, the spiral should make the same angle with the axis of the screw that the rope does. In this case, the rope is supported evenly on its lower side by the spiral. It is also necessary that the rope reach the top of the spiral at about the time the end of the trip has swung over upon the main track. To bring this about, the total length of the spiral, above the point at which the rope first touches it, must equal the distance the rope travels from the time it touches the spiral until the trip is upon the main track. This distance depends upon the grade of the tracks and the vertical distance between them at the knuckle. When too great, it can be

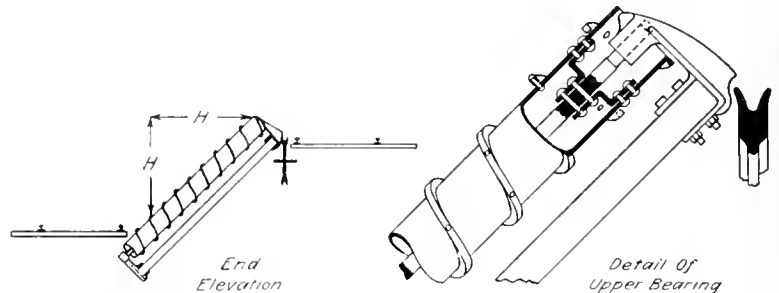

FIG. 2. DETAILS OF SPIRAL FOR RAISING ROPE TO KNUCKLE SHEAVE

reduced by keeping the empty track so far from the loaded track that the rope will not touch the spiral until the trip has nearly reached the frog between the tracks.

The length of the spiral depends upon the number of turns it makes around the pipe. This is increased by placing the pipe more nearly at right angles to the rope. This reduces the offset A (shown on plan, Fig. 1) measured from the point at which the rope first touches the spiral to the point at which it leaves it. If the spiral is to be parallel to the rope at the point of contact, and if the rope is to reach the top after it has traveled a distance L , the offset A is given by the formula

$$A = \frac{L}{2} - \sqrt{\frac{L^2}{4} - 2H^2}$$

In this, H is the vertical distance the rope must be lifted and A and L are as just defined.

The position of the spiral upon the pipe can be marked out for the blacksmith by wrapping around the pipe a piece of paper cut off at the angle the spiral is to make. This angle can be laid off by measuring on the side of the paper a distance equal to 1.414 times H , and, at right angles to this, the distance A , and completing the triangle by joining the ends of the two legs. This triangle may be made to any scale and applied to the pipe as often as necessary. The computation can then be checked by measuring the length of the spiral to see if it equals L .

If the trigonometrical tables are available, the angle of the spiral S may be obtained more simply from the formula

$$\sin 2S = \frac{2\sqrt{2}H}{L}$$

The horizontal angle P , that the projections of the spiral upon the plan makes with the perpendicular to the direction of the rope, is then given by the relation

$$\tan P = \sqrt{2} \tan S$$

This is readily laid out on the drawing board. H can be taken as the difference in elevation between the two tracks at the knuckle.

來 來

The Mining and Metallurgical Society of America has decided not to be absorbed by the American Institute of Mining Engineers. This move will undoubtedly or should be one good reason why the name of the American Institute should remain intact. The Mining and Metallurgical Society has a province of its own in which it is performing good work.

Answers to Examination Questions

Questions From Pennsylvania Bituminous Examinations for Second Grade Mine Foremen's Certificates, 1911

QUES. 1.—What are the legal requirements on haulage roads?

See Article IV, Section 8, of 1911 Bituminous Mine Laws. For copies of these laws address James Roderick, Chief of the Bureau of Mines, Harrisburg, Pa.

QUES. 2.—How would you reduce accidents from falls of coal and slate at the working faces?

ANS.—Teach and impress on the miners the necessity of sound-ing the roof and either pulling down the loose pieces or propping them up before doing other work. This applies both to coal left for roof support or to slate. In Wyoming 80 per cent. of the fatal accidents in coal mines in 1911 were due to roof falls, Fig. 1; and about 65 per cent. of the accidents in the bituminous mines of all states are due to the same cause. The coal at the face should be spragged when undercutting with the pick either by a small pillar of coal or a wooden block preferably the latter, as shown at *a* in Fig. 2. If the coal is on a pitch, cockermegs *b c*, can be used to advantage; in a flat seam, however, they are seldom used except possibly in longwall.

QUES. 3.—How would you prevent accidents from mine cars?

ANS.—Keep men off the haulage roads so far as possible. Place an alarm on the cars to give warning of the approach of the trip. Comply with the law; see that all entries have a clear space of 2½ feet from the side of the car to the rib on one side of the road, if in the judgment of the inspector the condition of the roof will permit, and keep the entries clear of obstructions. See that men obey the rules and do not ride on cars. Caution the drivers and car runners against taking unnecessary risks and see that they follow instructions.

QUES. 4.—How many gallons of water will be discharged per minute by a pump 10 inches in diameter, the length of stroke being 4 feet, and making 48 strokes per minute allowing 15 per cent. for slip of pump.

ANS.—To find the area of 10-inch diameter pump, $\frac{\pi d^2}{4} = \frac{3.1416 \times 10 \times 10}{4} = 78.54$. To find the number of gallons, multiply the area by the number of strokes and by the length of the stroke in inches, and divide by 231, the number of cubic inches in a gallon.

$$\text{Gallons per minute} = \frac{78.54 \times 48 \times 4 \times 12 \times .85}{231} = 665.77 \text{ gallons.}$$

The factor .85 is obtained by subtracting 15 per cent. from 100 per cent.

QUES. 5.—Supposing a fire should take place in the inlet airway and your men were at work inside of the fire. How would you proceed to rescue them.

ANS.—This is a broad question and a sketch map should accompany it, for the reason that men must act differently according as the mine is worked by slope, shaft, or drift. There is one thing to do in every case, send word to the men to run for their lives. If it is possible to dam off the fire with canvas curtains and lead the air about it through some split on the intake it should be done; this will keep the air going in the normal direction. It may be possible to reverse the current, but this should not be undertaken unless the men inside have been warned of the change. In non-gaseous mines the fan might be slowed or even stopped for a few minutes. In a recent fire at Lehig mine, Oklahoma, two boys saved a number of lives

by running to the different working places and warning the men. There were eight lives lost in this fire.

QUES. 6.—What are the legal requirements relative to ventilators and the ventilation of bituminous coal mines?

ANS.—See Article IX, Bituminous Mine Laws.

QUES. 7.—A shaft 50 feet deep is located on the side of a hill and is 500 feet from a creek bed which is 100 feet lower than the bottom of the shaft. Can the water be drained from the shaft into the creek by a siphon? Give reasons for your answer.

ANS.—If the shaft is full of water and at sea level, a siphon would work only to a depth of about 33 feet from the top of the shaft; it would then cease to flow because the weight of the atmosphere only supports a column of water between 33 and 34 feet, theoretically, at sea level.

QUES. 8.—In timbering rooms with a fair roof, how far apart would you place the posts; if the roof was broken how should they be placed? How should a prop be set to carry the greatest possible load?

ANS.—As far apart as conditions would warrant after testing the roof. The distance between posts is also determined by the width of a room and the method of working. In ordinary room-and-pillar work with a room 18 to 20 feet wide having fair roof, props should be placed every 10 feet along the room and about 9 feet from the straight rib and wherever the roof sounds hollow. If there is a roof crack a prop and collar or two or more props and collars should be placed as conditions demand. A prop should be squared at both ends, set perpendicularly, and have a cap piece driven in tight above it, so that there will be no roof sag. In some methods of mining and in robbing or working long wall, the props are pointed at one end so that they will broom when the weight of the roof comes on them. These props should not be used in ordinary room-and-pillar work except when pulling pillars.

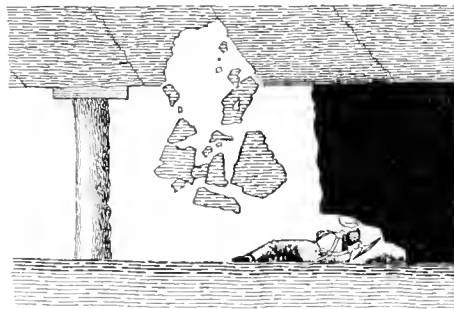

FIG. 1

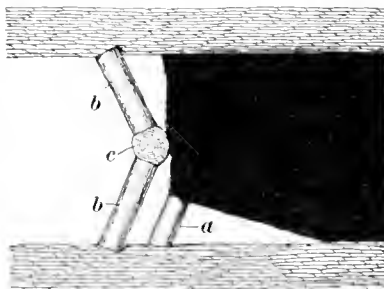

FIG. 2

QUES. 9.—Under what conditions would you consider coal dust dangerous in mines, and if much dust was being produced therein what precautions would you take to keep the mine safe?

ANS.—Coal dust is dangerous in a mine when it is suspended in considerable quantities in the atmosphere. It is also dangerous when it has accumulated where it can be stirred up in case there is a blown-out shot, a powder explosion, or a gas ignition, for in such cases it will increase the force of the explosion if ignited. Coal dust is dangerous when fine and should be cleaned out of main entries and as far as possible side entries. If the entry walls are washed down, the roads cleaned, and an occasional sprinkling of sand or clay from outside the mine is given the main haulage roads, especially at turnouts and for some distance at their ends, the danger of a dust explosion becoming general will be greatly lessened. In mines whose coal air slacks readily, steam jets should be used at the intake during weather when the air is dry. Also clean out the dust and surface with clay. In non-friable coal, water jets and clay surfacing should be followed. See also Article IV, Section 9 of Bituminous Laws.

QUES. 10.—How would you protect the lives of the workmen from dangers arising from the use of explosives in mines?

ANS.—Permit no new man to use explosives before examining him, and satisfying myself he understood the dangers connected with their use. See that the men undercut their coal and do not make deeper holes than their undercut. Show them how to point holes; see that they use the proper amount of explosive and properly tamp the holes as directed by law. See Article IV, Section 10. In case the miner shoots off the solid when breaking coal, see that the faces are in proper shape. Tell him where to put in and point his

hole; see him charge, tamp, and fire it. I would not permit indiscriminate blasting at any hour. I would follow the regulations relative to powder and detonators given in Section XVI.

QUES. 11.—If by applying 42,000 units of work you obtain 31,500 cubic feet of air per minute, what units of work will be required to produce 70,000 cubic feet?

ANS.— $(31,500)^2 : (70,000)^2 = 42,000 : x$, or 460,905 units of work.

QUES. 12.—If a pressure gauge at the foot of a column pipe in a shaft shows a pressure of 218 pounds per square inch what is the depth of the shaft, assuming the water in the pipe to be level with the top of it?

ANS.—The weight of a cubic foot of water is taken for ordinary calculation at 62.5 pounds, and exerts a pressure of $\frac{62.5}{144} = .434$ pound per square inch for each foot in height. If 218 is divided by .434 the depth of the shaft is found as 502 feet. Usually in rough calculations .5 pound is taken as the weight of 12 cubic inches of water.

QUES. 13.—In pillar work where the undercutting of the coal is done by mining machines, what system of working would you adopt to provide the greatest degree of safety to the workmen?

ANS.—Cut off the pillar from the rib at the end of the room. Cross-cut the pillar on the end with machine, standing props. Make a side cut with machine along the pillar to include the first proposed cut-through. Timber. Make cut-through with machine and another undercut on the solid pillar, spragging the cut. The men can now pull the pillar stump that is cut off from main pillar while the machine is undercutting for the next stump. The plan outlined must necessarily be varied with the method of working and in some instances machines could not be worked to advantage or with safety. When machines are used, three sets of props staggered should be used to protect the men and pulled as soon as the coal is loaded from the end. Props with the pointed ends set on the floor should aid in breaking down the coal as they will broom as the weight of the roof comes on them, besides are easier pulled than flat-ended props.

QUES. 14.—What are the general requirements in regard to the construction and use of doors on roads where hauling is done by animals or machinery?

ANS.—In Section 1 of Article IX of the Pennsylvania Bituminous Mine Law, it states: "No permanent door shall be erected or allowed to remain in the main entry in any mine, unless its removal shall be deemed impracticable by the inspector." Section 8 of the same article says how doors shall be hung and how they shall be attended unless a self-acting door is approved by the inspector. Nothing is said relative to the construction of doors. They should be made of wood, light but strongly braced so they will not sag; they should be hung on three-stick frames by long strong strap hinges that are pivoted to gate posts; and they should be made tight and to fit snug so little air will pass through or around them.

QUES. 15.—What are the legal requirements regarding the means of communication from top to bottom of shaft, where persons are raised or lowered, and what is the code of signals used in such cases as where persons or coal or other material are hoisted?

ANS.—The legal requirements for communication from top to bottom of shaft are found in Article VIII, Section 1. In Article XI, Section 9, there are rules for electric signaling. In Article XXV, Special Rules, the footman signals the engineer according to Rule 11, but Rule 10 says "the cager must be very careful to see that the springs or catches are properly adjusted so as to keep the car in its proper place, before giving the signal to the engineer." If both are allowed to give the signal some one will eventually get hurt. Rule 12 says the topman shall personally attend to the signals. Rule 31 gives the code of signals as follows:

One rap or whistle—to hoist coal.

One rap or whistle—to stop car or cage when in motion.

Two raps or whistles—to lower car or cage.

Three raps or whistles—to hoist persons. The engineer shall

signal back when ready, after which the person shall get on the car or cage, and then one rap or whistle shall be given to hoist.

Four raps or whistles—to turn on steam to the pumps.

QUES. 16.—How would you test safety catches used on cages at shafts?

ANS.—The writer knows of but one way to test safety catches, and that is to unfasten the rope from the cage so that the latter can drop. Several methods of doing this may be suggested; one is to rest the cage on chains, keeps, or landings at the top of the shaft, unfasten the rope and safety chains from the cage, pull back the landing chairs and let the cage fall. If the catches are in order the cage will not fall far; contra, a new cage should have been ordered before the test.

QUES. 17.—What are the inexplusive gases found in bituminous mines? Give their symbols, specific gravities, where they are found, and their effect on life and health. What method would you adopt to remove them to keep the mine in a safe and healthful condition?

ANS.—Carbon dioxide and nitrogen. Carbon dioxide CO_2 , specific gravity 1.529. This gas is not poisonous, but it extinguishes life because it diminishes the quantity of oxygen necessary for life in the atmosphere. It is claimed that if 2 per cent. of the atmosphere is carbon dioxide and it is breathed for long periods, the blood will become impure. When air contains more than 2 per cent., say up to 8 per cent., men labor with difficulty and have headaches which increase in violence with the CO_2 . Above 8 per cent. CO_2 men assume risks, as they may lose consciousness and die if not removed, and when the percentage reaches 14 and more, rapid smothering like drowning occurs.

Nitrogen, N , specific gravity .978. Nitrogen forms 79.3 parts by volume of the air we breathe, and consequently when not in combination is harmless. When chemically combined with oxygen it forms nitrous or nitric fumes which are both harmful and poisonous. If united with hydrogen it forms ammonium, which is also injurious. Air containing too little oxygen and too much nitrogen would smother a person as readily as carbon dioxide.

QUES. 18.—When the timbers in a drift are broken and it is necessary to replace them, and enlarge the opening, where would you start the work and how would you instruct the workmen to proceed?

ANS.—Commence the work of enlarging several sets away from the broken sets and timber toward the trouble. Would start work where there was a chance to retreat in case there was a run of ground which would fill the drift. Caution men not to work under loose ground and to protect themselves by advancing the timbering as fast as possible, using false sets if necessary to remove the old sets and broken ground. The method to employ in taking up the ground will depend upon the kind of material the miner has to contend with, whether rock, slate, or dirt.

QUES. 19.—What is the efficient limit to which the air-current in a mine can be split?

ANS.—The efficient limit to splitting an air-current depends on the areas of the intake and return airways in connection with the various splits, and the power for circulating the ventilating current. Assuming a constant power, the quantity of air produced will be in proportion to the number of splits. Owing to the resistances to the passage of air in the shafts and main entries to the place where the splits occur, the quantity of air in circulation does not increase in the same ratio as the number of splits, and the velocity of the air in the several splits is therefore, materially lessened as the number of splits is increased. The reduction of the velocity in splitting, where the power remains constant, determines the limit of this means of increasing ventilation, for the state law requires that a certain quantity of air per minute shall be furnished man and beast, and that not more than a given number of men shall work on one split.

QUES. 20.—What are the legal requirements in reference to the care of persons injured in or about the mines, and what are the mine foreman's duties in the event of a serious or fatal accident?

ANS.—Article XIII of the Bituminous Mine Laws deals with this question. The foreman is obliged to report serious or fatal accidents once each week. See Article IV, Section 19.

ORE MINING AND METALLURGY

Miami Concentrating Mill

A Successful Concentrating Mill of 4,000 Tons Daily Capacity Working on Low Grade Copper Ore

By C. E. Golding*

The mine and mills of the Miami Copper Co. are at Miami, Gila County, Ariz., 7 miles west from Globe, in what is termed the Red Springs, or Miami district. The company holds 1,222 acres of land, of which 222 acres are mineral land, 555 acres are for mill and power purposes, and 345 acres are held for water rights.

The Miami Copper Co.'s mine and the system of mining followed was described by R. L. Herrick, E. M., in *MINES AND MINERALS*, July, 1910, page 751. Mr. Herrick also described the con-

The mine is being worked through four shafts, No. 1 or Red Rock shaft, and No. 4 or main shaft, being over 700 feet deep. No. 1 shaft has three compartments and is sunk in the supposed center of the ore zone. No. 4, the main working shaft, is equipped on the basis of 5,000 tons of ore daily and is sunk outside the supposed ore zone; that is, the proven mineral ground. The mine carries almost a solid body of ore said to be 450 feet thick, for which reason and because the ore body is wide, the caving system of mining is practiced. The copper assays from this ore deposit average 2.4 per cent. copper. The first level is driven in ore at 220 feet from the surface, the main working level is at 420 feet from the surface, intervening levels are 50 feet apart, with the mine blocked out in 50'×50' sections. In each block there are two chute raises for transferring ore from the upper levels to the main working level. All of the ore is taken from the three upper levels, the 50'×50' blocks having chute raises on each side. Sections of each block



FIG. 1. HEAD-HOUSE AND BUILDINGS, MIAMI MINE

centrating mill so far as then completed, in the August, 1910, number of *MINES AND MINERALS*. The mill was originally planned for 1,000 tons daily capacity, later increased to 2,000, then to 3,000 tons, and finally to 4,000 tons daily, in eight units of 500 tons each. The mill was planned and built by H. Kenyon Burch, under the supervision of Louie A. Wright, general manager, and B. Britton Gottsberger, manager. Since then B. B. Gottsberger has become general manager, Mr. Wright having gone into Mexico on similar business.

The bodies of ore have developed beyond expectation, which accounts for the increased size of the mill. The first unit of the mill went into commission March, 1911; in April four units were at work, and at present five, and probably six.

Fig. 1 shows the hoist house, head house, crusher building and concentrator; to the right in the distance is the smoke stack of the power plant. The smoke in the distance, to the left, is Old Dominion Smelter 7 miles away.

* Miami, Arizona.

25 ft. × 25 ft. are blasted into the chutes and in this way the ore in the upper levels is being worked without permanent timbering. On the 580-foot level there will be another working level, and still another on the 700-foot level which will be duplicates of the 420-foot working level. These lower levels will not be extensively worked until the entire ore body above the 420-foot level is removed, which, it is estimated, will require 10 years at 5,000 tons per day. The entire haulage level is electrified, electric lights and trolley lines are in every drift, and the latest type of Goodman locomotives are used to haul the ore to the main hoisting station, where it is automatically dumped into a pocket that is 30 feet square and 50 feet deep. From this pocket the ore passes through chutes, the gates of which are opened and closed by air, to a 7-ton skip, and is hoisted and dumped in the head-house bins, which are at the extreme north end of the concentrating mill in the rear of the head-house shown in Fig. 1. From the head-house the ore is drawn off, crushed, and then carried on a conveyer belt to one of the six steel tank-shaped ore bins shown.

From each of the steel bins a conveyer belt carries the ore to rolls; then another belt carries it to the Chilian mills, after which it flows to the concentrating tables. Men of experience in the construction and operation of concentrating mills state that this is the most complete and up-to-date mill in the country, and an 80-per-cent. recovery of copper is claimed by the management at a cost of about 8 cents per pound, which is much lower than the average mill is doing in this section of the country.

The crushing plant consists of two gyratory crushers, each of which is run by one 50-horsepower General Electric induction motor. The capacity of the crushers is 2,000 tons each in 24 hours. There are two pairs of rolls beneath the crushers, which have the same capacity as the crushers and which handle all ore that passes through them. These are driven by a 75-horsepower General Electric induction motor. In each of the six units a set of rolls handles all of the ore that passes through the unit, power being furnished by a 50-horsepower General Electric induction motor. Chilian mills are doing duty in the third crushing process to which the ore is subjected before it reaches the tables in units 1 and 2 of the mill. In units 3 and 5, Chilian mills are also used. In units

the launders that carry it from the mill. This dam will last for about 2 years, after that time the tailing will flow to the next cañon, which is about 1 mile from the plant. The concentrate flows through launders from the tables to an underground passage which empties into a concentrate tank connected with a vacuum pump whose purpose is to extract the water. The pump leaves but 8 per cent. moisture in the concentrate. After the moisture is taken out by the pump the concentrate contains 50 per cent. copper and 8 per cent. moisture, or when dry the concentrate contains 58 per cent. copper. Eighty per cent. of the water used in the mill is recovered for reuse, and this is a very important item, as the water supply was the first big problem that the management had to cope with, because there is not sufficient water closer than 30 miles, except in the Old Dominion mine at Globe, $7\frac{1}{2}$ miles from the mill, which the management purchased, and therefore the 80 per cent. that is reclaimed is a great saving in the cost of production. The Burch pump station is one of the best of the kind in Arizona. The water flows from the Old Dominion mine to the Burch station, on Pinal Creek, which is 4 miles from and about 150 feet lower than the mill. The station is fitted with two Nordberg electric pumps, which, when



FIG. 2. VIEW LOOKING NORTH. A PORTION OF MIAMI, POWER HOUSE AT RIGHT

4 and 6, however, pebble mills are doing better work at 2 cents per ton less than the Chilian mills in units 1, 2, 3, and 5. Two of the Chilian mills are driven by a 100-horsepower General Electric induction motor, while the same power is being used to drive two pebble mills, which do the same amount of work as the Chilian mills.

The concentrating, sand, and slime tables used throughout the mill have proven satisfactory in recovering concentrates at low cost of operation and maintenance. There are 324 concentrating tables, 132 sand tables, and 192 slime tables. There are 20 sand tables in each of the six units on the main floor, and two in each of the sand tunnels 20 feet below the main floor. These 20 tables in each unit are driven by a 24-horsepower induction motor, and the two tables in the tunnel are driven by a 5-horsepower motor of the same type. There are 30 slime tables in each of the six units on the main floor, and two in each of the slime tunnels. In each of the units on the main floor one 20-horsepower induction motor is used to drive the 30 tables, and in the tunnel a 5-horsepower motor of the same make is the driving power for the two tables. The sample taken from tailing as it leaves the mill shows that more than 80 per cent. of the copper has been extracted from the ore during its travels through the mill. In the cañon below the mill there is a large tailing dam which was naturally formed by the tailing after leaving

driven at 150 revolutions per minute, will handle about 1,600 gallons per minute. Each of these pumps is driven by a 400-horsepower synchronous motor, using 6,600 volts, and these are the only motors that use more than 600 volts; but they also drive a small Ingersoll-Rand compressor, which is used for forcing a small quantity of water from a number of bored wells to a tank where it is stored for emergencies, such as an accident at the Old Dominion mine, at Globe.

The Miami Copper Co. has an excellent power plant, probably the most modern in the state of Arizona. The steel and concrete power house, shown in Fig. 2, is 70 ft. \times 264 ft., and is located on a flat below the mine, where it may be reached by side tracks from the Gila Valley, Globe & Northern Railway. The power generated consists of compressed air and a 25-cycle alternating current of 6,600 volts.

The three generators are direct connected to three four-cylinder triple-expansion engines with 19"–37" \times 48" cylinders on one side and 40"–40" \times 48" cylinders on the other. These engines take steam at about 185 pounds pressure and 100 degrees superheat. Two small generators are installed to act as exciters when starting the large generators, it having been found that the fields of alternating current generators are keyed up more readily when exciters are used.

There are also two four-cylinder triple-expansion air compressors with a capacity of 4,000 cubic feet of air per minute at 90 pounds pressure when the engines are making 80 revolutions per minute. These compressors supply the hoisting engines, the air drills, and whatever other machines need compressed air. The steam plant is fitted with three batteries of 600-horsepower each tubular boilers, burning fuel oil to generate steam. The mill building, of steel and

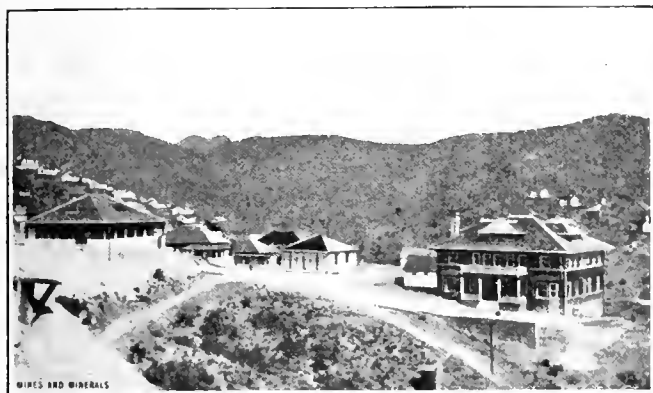

FIG. 3. MIAMI COMPANY MINES AND OFFICE

concrete construction, is 600 feet square on the main floor with an L at one end which is used for the machine and carpenter shops, where the equipment is sufficient to do any class of work in the various departments. The building is covered with 2-inch tongued-and-grooved pine with asbestos paper on top. A skylight 16 ft. \times 50 ft. over each floor of each unit and a large number of windows in the sides of the building give ample light. The foundations of the power house are constructed entirely of reinforced concrete, and the main walls and roof are constructed of the same materials. The smoke stack, of reinforced concrete, is 18 feet in diameter at the base, 12 feet in diameter at the top, and is 160 feet high. The Burch pumping station building is of steel and reinforced concrete with corrugated iron roof.

The company has been liberal in providing comfortable quarters and amusements for the employees. The management was instrumental in the erection and maintenance of a first-class Young Men's Christian Association building, where all classes of amusements are to be found. In the valley, a short distance from the mine and mills, there has arisen in 2 years a little city of 1,000 population. This town is not wholly dependent on the Miami mine and mills for support, however, as there are a number of other promising properties in this district where a larger number of the miners are employed and where a much greater number will be needed in the near future. The Cole-Ryan interests have the Live Oak and Inspiration properties here and they will probably commence the erection of a large mill on their property, which joins the Miami, in the near future. Several other large properties of proven value are owned by companies who hope to build large mills near here.

Miami is at the extreme western end of the Arizona & Eastern Railway, which is a branch line of the Southern Pacific, and leaves the main line at Bowie, 134 miles east of Miami. Preparations are being made at the present time to extend the railroad several miles farther west, where numerous mining properties are awaiting the arrival of the road before extensive development can be done, owing to the fact that heavy mining machinery cannot be transported over the wagon roads.

來 來

A bulletin of the United States Geological Survey states that the talc industry in the United States reached a maximum production of 150,716 short tons in 1910. This consisted of 15,425 tons of rough, worth an average of \$3.69; 9,352 tons of sawed slabs, averaging \$8.34; 22,363 tons manufactured articles, averaging \$22.51, and 103,576 tons of ground talc, averaging \$9.21 a ton.

The Coker Creek Gold Field

A Description of Some Tennessee Deposits That on Account of Low Grade Have Attracted Little Attention

The following notes are abstracted from an article by George H. Ashley, State Geologist of Tennessee, in "The Resources of Tennessee," published by the State Geological Survey.

Coker Creek flows in a broad open valley, partly in Monroe County and partly in Polk County, Tenn., at the western foot of the Unaka Mountains, which separate Tennessee from North Carolina. The gold belt in Tennessee is more than 50 miles long, but the Coker Creek district has produced the most, although almost nothing has ever been published concerning the field. The presence of gold on Coker Creek, tradition has it, was imparted to white people by the Cherokee Indians, and as early as 1827 Jacob F. Peck and Le Grande Henderson entered the field and did some mining. The first gold deposited in the mint from Tennessee was in 1831. In 1833, \$7,000, the highest output on record, was made, and from that it dwindled to \$149 in 1853.

The gold occurs under six different conditions, in three of which it occurs practically in place, and in the other three by transportation from its position in one of the first three conditions.

First and foremost, it is found in quartz veins. The quartz veins represent quartz material brought from an unknown depth in solution in water and deposited among the rocks, as now found. The fact that in general they agree with the general position of the country rocks over such long spaces suggests that in the folding of the rocks the latter were broken in the folds sufficiently to make lines of passage, which have been utilized by the ascending or descending waters. Under relief of pressure or other cause, deposition of the silica and other accompanying minerals took place, forming the vein. In addition to the gold and pyrite the veins were observed to contain magnetite and a white mica, possibly muscovite, and garnet, in addition to the iron oxide resulting from the decomposition of the pyrite.

As is usually the case, the association of the gold and pyrite has been close, and where examined, the visible gold appears to be confined rather closely to the faces of the vein or possibly the oxidized spots in the middle of the vein. When a block of the vein is removed and examined gold is usually visible to the unaided eye, and more abundantly if the face of the block be examined with a

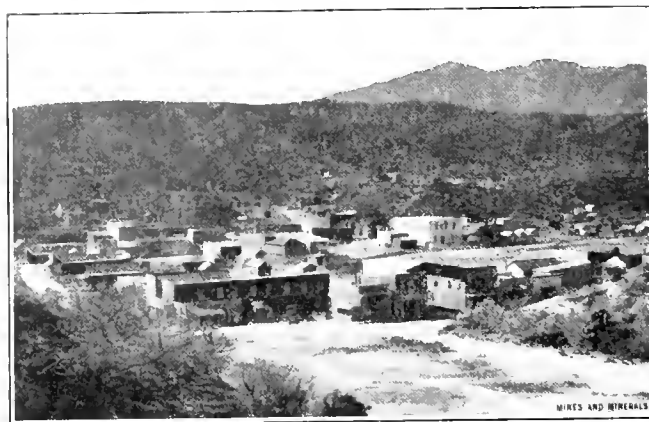

FIG. 4. VALLEY SETTLEMENT, MIAMI, ARIZ.

lens. The gold appears in fragments, from several times the size of a pin head to mere specks only visible under the lens. In places the particles are clustered together, or appear as strings of particles, or even appearing to make a network. Much of the gold appears as though plated on to the surface of the vein ready to be removed by rubbing, but much of it is in the clear quartz in places at least $\frac{1}{4}$ of an inch away from any oxidized edge. Removed from the vein

and examined under the lens, the gold particles appear either as well rounded, minute nuggets, either globular or elongated, more commonly the latter, with rough surfaces of a bright "old gold" color; or they appear as thin sprangling masses or films of irregular shape and extent and much stained from iron rust. The two kinds of gold will be found in the same panning made from cleaning the face of the quartz vein, but appear quite distinct, the rounded nodules or nuggets always appearing clean, while the thin, sprangling masses always appear rusty. Just the relation of the two forms of occurrence was not worked out.

The second mode of occurrence is in the country rock. Pannings were made of the shale either side of the Whippoorwill vein, the samples being taken from just outside of the contact of the vein away from the vein for a distance of 2 feet, and these gave a good showing of "color," and in one case a considerable nugget. Samples of sandstone from the Barner lead to the northwest of the Whippoorwill vein are reported to have assayed 20 to 25 cents a ton of gold. These samples did not include any of the quartz veins. It is claimed that similar tests previously made in a number of parts of the field indicate small quantities of gold in the rock outside of the quartz veins.

The third mode of occurrence is the occurrence in what Becker calls saprolitic material. That is the weathered surface rock (saprolitic meaning rotten) in which the gold was originally mainly in the thin veins of quartz rock, but the decay of the veins along with the country rock has released the gold, which remains and may accumulate in the soil and weathered surface rock. In one or two areas it was reported that the surface panned out quite rich, but that after passing the grass roots little gold was found. Taking into account the topography, it was thought that the gold might have accumulated, practically in place, from the decay of quartz veins.

The fourth form of occurrence is closely related to the last. In this the hilly slopes below the outcropping of the several veins, or belts of veins, have sometimes been found to be rich ground, due to the accumulation of the gold from the decayed veins on its way from the outcropping of the veins to the valley below. As the veins usually outcrop in the crests of low ridges, the sides of those ridges should prove profitable ground.

The fifth mode of occurrence is in what may be called the high level placer gravels. In some cases these correspond to the "second bottoms"; in others to interstream areas of gentle slope. On the east side of Coker Creek the land has an even, gentle slope for some distance to the foot of a sharp ridge of quartzite. The present stream channels are cut from 40 to 70 feet below the level of this slope, becoming less as Coker Creek is approached. A small amount of hydraulicking has been done in these levels, indicating pay ground. These gravels probably date back to the time when the eastern tributaries of Coker Creek had not cut below that level, but ran out directly upon it, from the gaps through the quartzite ridge. The second bottoms along Coker Creek possibly date back about as far. Pannings made from these gravels give abundant "colors."

The sixth mode, which has been the principal source of gold obtained to date, is the occurrence of the gold in the gravels of the present stream bottoms. Where the Madisonville-Murphy pike crosses Coker Creek the bottoms are about $\frac{1}{2}$ mile wide, but gradually narrow up stream. The side tributaries have rather narrow bottoms, ranging from a maximum of 100 to 200 feet down to a few yards wide, and from a fraction of a mile to a mile long, depending on their size and length. Below the pike mentioned the bottoms on the creek vary according to the rock through which the stream passes. The depth of these stream gravels ranges from 2 to 6 feet, or more. Very few of the gravels have been worked where the deposit was more than 6 feet deep. As usual, the gold has been found mainly at the base of the deposit in contact with the underlying bed rock. In fact, in past practice, the bottom 6 inches alone has been worked for gold, the rest being treated as so much overburden. The fact that many of the large nuggets have been

picked up in the overburden, where they were seen simply because of their large size, indicates that were all of this mass to be reworked, it may be found that the upper part of the material has still considerable gold in it.

That the quartz veins are at least in part the source of the gold, is beyond question. That they are gold bearing over long distances and in many places, may be considered demonstrated, but that they carry gold in sufficient quantity and under such conditions that it can be worked at a profit, remains to be demonstrated. It may be readily calculated that if one 6-inch vein of the Whippoorwill lead were to be continuous for 5 miles on the surface and to a depth of 2,000 feet it would yield 1,000,000 tons of vein material, which would yield as many million dollars as the average ton of ore contained, less the necessary losses in mining and milling. If the Whippoorwill vein carries several distinct veins either individually of as great extent as just supposed, or equivalent to that extent, and with a total thickness of from 1 to 2 feet, there would be 2,000,000 to 4,000,000 tons of ore in that one vein from that distance. And if the vein carried, at an average, only \$10 a ton, there would be from \$20,000,000 to \$40,000,000 involved. If \$30 a ton, three times that, or \$60,000,000 to \$120,000,000. Multiply that by the number of veins in the district and by the full length of the belt, 50 miles or more, and it is possible for the fancy to lose itself in a dream of wealth. But remembering the old saying that every dollar of gold gotten out has cost \$2, and that the average quantity of gold per ton in any of those veins is as yet an entirely unknown quantity, and that quartz mining, especially of thin veins, is an expensive operation, and its final treatment and the recovery of the gold still another, the problem looks different. It must be remembered that the mining and milling of quartz ore will cost from 50 to 100 times as much per ton as the similar treatment of placer gravels. So that where gravels may be profitably exploited when they contain only a few cents per ton, a gold-bearing quartz vein may prove profitless, even though it contain as many dollars to the ton. Perhaps, the extreme case of cheapness of milling and mining is one cited in the report of the 11th Census, where mining cost 31.4 cents a ton and milling 20.8 cents a ton. Ordinarily the milling alone will cost from 50 cents to \$2.50 a ton, while the mining will run from \$1 up, according to the local condition of the vein, etc.

In conclusion, the trip demonstrated to the satisfaction of the writer—

1. That the Tennessee gold belt *may* prove to be a very tangible asset of the state, if its development be undertaken by men who know their business, using modern, up-to-date methods and machinery.

2. That thorough systematic prospecting and surveys will be necessary to demonstrate the feasibility of its profitable exploitation at any point, or in any district.

Finally, if any one feels the lure of gold mining in the blood, let him get him a pan and pick and shovel and lease the privilege of digging up some 40-acre tract, but don't invest in any mining stock. In the first case the investment is small, the outdoor exercise is good for the health, and he may get enough gold to pay railroad fare and expenses. In the second case the chances are nine out of ten that he will have ample time to reflect on an old verse about a "fool and his money."

Gold mining in Tennessee, as in the other Appalachian States, has passed the first "gold rush" stage. If any money is made from it in the future it must be made as it is being made in the neighboring states, by men with abundant personal capital, thoroughly familiar with the mining business, knowing, or having in their employ, capable, trained mining engineers and metallurgists, and with ample opportunity to give the work their personal supervision and attention. After a company has been paying dividends for twenty years its stock may be safe for the average investor, provided he first assures himself that the "ore in sight" is not practically exhausted.

Lest any one think the above statement overdrawn, it may be well to study the following figures from the report of the 12th

Census on "Mining," remembering that a majority of gold and silver companies are not incorporated and are not selling stock.

DATA ON INCORPORATED GOLD MINING COMPANIES IN THE SOUTHERN STATES (1902)

States	Number of Companies	Capital Stock	Dividends Paid	Assessments Levied
Alabama.....	3	\$ 1,514,000		
Arkansas.....	1	1,577,000		
Georgia.....	19	19,182,000		\$ 5,000
North Carolina.....	16	9,884,500		32,000
South Carolina.....	2	750,000		21,000
Virginia.....	4	2,600,550		
Total.....	45	\$35,508,050		\$58,000

In other words, 45 incorporated companies with an authorized capital stock of \$35,500,000 levied assessments to the extent of \$58,000 and paid dividends of zero dollars.

In the same year the production of three of those States was as follows: Georgia, 7,214 fine ounces, worth \$148,309; North Carolina, 3,226 fine ounces, worth \$65,722; South Carolina, 6,747 fine ounces, worth \$139,389.

If, however, you are a mining man, or have had previous experience in connection with gold mines, and have or control sufficient capital to prospect thoroughly and to develop on a modern scale (if prospecting makes a favorable showing), then the writer believes that the Tennessee gold belt is well worth serious investigation, beginning at Coker Creek and extending northeast and southwest.

采 采

Leadville, Colo., Fissure Veins

By Oliver C. Ralston*

Fissure veins in Leadville, Colo., district, until recently have been unnoticed and lightly considered, no one believing in them as a source of mineral wealth, due to the fact that few veins have been found in the old part of the camp, and that these are usually very poor, the opinion grew that there was no use in paying much attention to them. Nearly all the paying deposits had been in some way connected with the two sheets of lava, known as the Leadville gray and the Leadville white porphyries, which alternate with two limestones and two quartzites of pre-Carboniferous age and therefore large irregular replacement ore bodies in the limestone came to be regarded as the only type of deposits worth considering.

However, owing to the initiative and the faith of a few men, a fissure was finally discovered which proved to be a wonder. It was opened in the New Monarch property in what was regarded as the extreme northeast corner of the camp. Its extension was opened later by the Luema Mining Co. on the north, and in the Silver Spoon claim beyond that, going under Big Evens Gulch without deviating. Half a dozen other veins are known, some of which are cut in the Yak tunnel. The Silent Friend and the St. Louis veins have shown results, but the Monarch, or Cleveland, fissure has attracted the most interest, as it is the most extensively developed.

The New Monarch vein strikes to the northwest and is nearly vertical. It extends throughout the grounds of the New Monarch Co., the Luema, the Silver Spoon, and extends north into Prospect Mountain. It is known throughout 3,000 feet and has been a good producer for the whole length. In depth the vein has been worked 845 feet, the last 195 feet being entirely in the underlying granite. As it is a fault fissure, one wall has granite for the lowest 400 feet. It cuts through the sedimentary rocks up to the surface wash. In width it varies from 30 to 180 feet, and is filled with several kinds of porphyry.

The granite of the walls is altered by the heat of the lavas squeezed up through the great fissure and by the solutions coming from the lavas. The granite is very much altered for several hundred feet on each side of the fissure—in some places being kaolinized—but it still retains its hardness, and cross-cuts are driven in it only with difficulty. When broken it has a black glazed appearance due to its hornblende and altered feldspar, although its color varies much with the varied alteration.

*Leadville, Colo.

The vein filling is not all the same. The gray and white porphyries found in the main part of the Leadville district are both found in the vein. On the east wall is a "bird's-eye" porphyry, often 40 to 50 feet thick, while on the west wall is the familiar gray porphyry. The two porphyries were probably not erupted at exactly the same time, and from their resemblance to the two lava flows of the district proper, some believe that all the lava came from this and similar fissures. The whole vein seems to have been mineralized at the same time and in some places nothing much but quartz remains. There is also some evidence of later movement and slipping, as the vein matter is badly ground up along certain planes.

One encouraging feature is that ore has been found throughout the length of this fissure so far as developed that carries remarkably uniform amounts of gold and silver, the shipments averaging from \$16 to \$25 in gold; 12 ounces in silver; 8 to 10 per cent. zinc; and about 1½ per cent. copper. The ore is fairly siliceous, which makes it a desirable flux for other Leadville ores. The richest ore, however, comes in streaks varying from ½ inch to 6 inches wide, that occasionally widen into several feet of ore carrying rich gold-tellurium minerals. The gold-silver ratio of much of this stuff is the same as that on the sylvanite, krennerite, and calaverite of Cripple Creek. The presence of a large percentage of lead in the ore points toward the mineral being a mixture of nagyagite with either sylvanite, calaverite, krennerite, or petzite. In this ore the gold will vary from ½ ounce to 30 or 40 ounces per ton.

In the upper part of the vein, where it passes through the sedimentary rock, ore worth as much as \$10,000 a ton was found, and in three instances replacements extending out into the blue limestone for several hundred feet have been mined. These deposits had the same general direction and were doubtless formed along a series of minor fissures roughly parallel to each other, and cut by the big fissure at an angle of about 60 degrees. The quartzites of course are poor. At the junction of the sedimentary rocks with the granite the ore assays only \$15 or \$16 per ton. The New Monarch mine has eight levels, and in the lower ones secondary enrichments have been found in almost everything—even in the tellurides of gold—a fact of particular interest to geologists. There seems to be little sign of the richness of the ore decreasing with depth as yet.

The pay streaks are richest on the western edge of the vein, although good ones are found on the eastern wall as well, and knife-blade streaks that traverse the porphyry and quartz filling sometimes widen out into ore bodies at the intersections.

At one place the vein has cut a pegmatite dike, and at the intersection with the big fissure the mica plates were so large several mine-car loads were taken out.

The New Monarch property is operated through the Cleveland shaft, 845 feet deep. The Luema property is operated through the Luema shaft, 750 feet deep, and connected with the New Monarch mine at the second and fifth levels. This company has about the same kind of ore; but one interesting thing observed here is that often the gold is intimately associated with the zinc.

The Silver Spoon shaft is 600 feet deep, and the mine is connected with the Luema mine on its fourth level. Drifts being driven toward Prospect Mountain to the north are in a fine ore from 5 to 7 feet wide and carrying 5 ounces of gold, 75 ounces of silver, and 10 per cent. copper to the ton.

It has been noticed that the New Monarch vein follows the Ball Mountain fault and, while it has been opened in the Alps mine south of the Monarch, good ore shoots have been found. Assays from the prospect holes along the fault often give good gold returns, but little has been done here yet.

It is the opinion of several of the men who are now developing this vein that other fissures farther north and east will prove to be more or less like this one and a great deal of interest is directed toward any new finds in this direction.

I am indebted for much of the information herein contained to Mr. J. B. McDonald, the present manager of the New Monarch, and to Mr. Penderly of the Yak Tunnel Co.

Fundamentals in Technical Education

The Beginnings of Technical Education—The Modern Tendency Toward Multiplicity of Studies

By Regis Chauvenet*

No discussion of Technical Education would be considered complete, indeed it would hardly be worth calling a discussion, if it did not include some attempt at a retrospect.

When we start into history in this line we quickly discover that in any "institutional" sense technical training is so modern that there are those living who can remember its beginnings in the United States.

One generation further back would date its start, in any modern sense, in Europe.

Perhaps of all countries in the world the United States lives the least in the past. "There are reasons," but they do not belong here. Last month we read a magazine story in which the hero fought first at Gettysburg, and *afterward* at Antietam. In the latter battle he was wounded, and then left "Grant's Army!"†

If the leading events in a great civil war thousands of whose survivors are still with us, are already so dim in the mind of a professional writer of "historical" fiction, what can be expected as to knowledge of educational beginnings and developments?

But we need not select "Technical Education" as modern, when the very idea of popular education and of the public school was a new idea to our grandfathers.

The actual beginnings of technical training are difficult to trace, because they were largely individualistic. The specialist took students, or it may have been apprentices, in early days, this being the first approach to the "institution" of today.

The famous laboratory of Berzelius in the early years of the nineteenth century is a brilliant example. Here were trained many of the chemists whose distinction started with the title of "Pupil of Berzelius," and through whom a knowledge of the "New Chemistry" spread throughout Europe.

As physical, chemical, and mechanical knowledge grew, and as applications began to be known and appreciated, a natural demand arose for systematic instruction in the new field. It would have been too much to expect that this demand should have taken a specified and logical form at its outset.

That it should encounter opposition was inevitable. The upholders of the Universities of Europe hardly granted the name of "education" to courses in the physical sciences.

Indeed, the demand for technical instruction, far from originating in the Universities, arose outside of them, and it was long before it obtained recognition in University courses. Little by little it has pushed its way, first in separate and specialized schools, later in "departments" of institutions of broader scope, until today the "department" seeks to rival the institution devoted solely to applicative science.

Later, some attention will be given to the merits of the two systems, as well as to the still more modern "correspondence school." We are not blind to the merits of strictly individual instruction, but as its details would be almost as numerous as the individuals, it can hardly be discussed in any but the most general way, and can hardly be compared, for lack of data, with any systematic form of scientific education.

Meantime, to clear the ground, as it were, we devote a few paragraphs to a tendency very apparent in our public schools of today, which far from originating in them, or being confined to them, seems rather to have crowded into them from above. We shall give it a title not original with us: **MULTIPLICITY.**

When, years ago, Cushing led from their reservation in the far southwest a band of Zuni Indians, through the country and to the Atlantic coast, he determined to introduce these children of nature to the "whole show" of the white man's civilization.

Accustomed in their native homes to food not only of the simplest kind, but wholly lacking in variety, we can hardly imagine their feelings when they sat down at the Palmer House in Chicago, to a sumptuous dinner of ten courses.

The chief of the party, a man of note in his tribe, said to be over 80 years of age, "tackled" the menu, and—brave old man—he ate from every dish.

When the feast was over he was asked "how he felt." Memorable in the annals of gastronomy should be his answer:

"My stomach is full, not only of food, but of much fighting."

It may be that our simile does not hold good, owing to certain organic differences between mind and stomach.

It may be that those biologists are right who maintain that the more the mind acquires the greater its capacity for more knowledge.

But of this at least we are sure, for we stand on the basis of experience. Too many subjects studied at the same time lead to a result not unlike that so laconically epitomized by the aged chief.

We believe that fundamental knowledge in a few lines will go further than any attempt at acquisition of all the branches of applied science.

It is a trite observation that the knowledge of the world at large, viz., the totality of knowledge, is so great that not only no one man but probably no one hundred men could possibly acquire enough to be fair exponents of all current information. It is obvious, too, that this condition of things can never "go backward" but will become more and more accentuated with the growth of research and experience.

It is said, to take up only a single line, that today there are in Europe, with Germany in the lead, over 6,000 trained chemists engaged in research work. Some of these are in what may be termed purely scientific fields, others are the experts of technical works, but all are working, seeking, experimenting, and discovering. A distinguished scientific writer recently remarked that it would take more than one man's time reading every day and all day, to get through with the titles alone of all of the scientific books and essays now being poured forth, without waiting or having the time to wait, for the slightest perception of their subject matter.

In fact the epoch has long since passed in which any scientific man need be ashamed to confess in respect to numerous departments even in his own "specialty" that he "knows nothing about it."

In trying to keep pace with the era, the error which I have endeavored to compress into one word, "multiplicity," arises in our schools. Not confined to the higher institution, which might indeed lay some claim to include anything and everything in its curriculum, it reaches down below the college line; it invades the high schools; its demands are heard in the "grades"; it may even appear in the Kindergarten; and, who knows, in the nursery.

Do we try to train an athlete to become a baseball player, an oarsman, a wrestler, a boxer, a runner, and a swimmer?

Hardly. But we have been in danger of attempting something cognate in mental development.

Many and many a high-school graduate can tell you of his courses in chemistry, geology and mineralogy, physics, and I forget what other branches in modern science. He has "been through" trigonometry, he has mastered mechanical drawing. Let us not attempt to enumerate all of his accomplishments. As a rule he stumbles badly over decimals, and knows very little indeed of any applications of ratio and proportion. Later I shall give one or two "frightful examples." I am glad to perceive that a reaction is setting in in certain quarters, but in others, alas, the tide is still rising. Pardon the mixed simile.

It takes the world some time, and with some hard rubs, to learn the difference between knowledge and wisdom.

Opposed to this "multiplicity" is a counter tendency but little developed as yet in the United States; viz., exclusive devotion to a special line.

It was about 100 years ago that a young Italian with a natural tenor voice asked the most noted instructor of his day to take him as a pupil.

* Mining Engineer, Denver, Colo.
† Reversed Chronology.—EDITOR.

"If I do so," was the reply, "you must promise to follow my method and stay my time, and you must make a contract with me to that effect."

The young tenor complied with every condition, and coming to his first lesson had placed before him a closely written sheet of musical exercises. This sheet occupied them for an entire year.

The second year opened, but the sheet was not changed. The pupil wondered, and at last protested. He was merely reminded of his promise, and the work continued. The third year was far advanced when he passed, not from this eternal page, but into lessons in the same themes in phrasing, declamation, and expression.

"Alas," said the tenor to his friends, "I have tied myself to a tyrant who for three years has held me to the merest elements."

But one morning just as the third year was almost gone, the master said: "Go, my son, you have no more to learn. *You are the first tenor of Italy!*"

Specialization in the professions, however, in the United States is as a rule the result of devotion to a single line after graduating in a general course.

So far we have spoken of technical education as though it were a matter of course that any young man who contemplated technical work which involves scientific principles, should take a course in scientific elements, as preparatory. It is worth noting (since we are still engaged in something of a historical retrospect) that there were in the field two forces opposed to scientific education. One of these was led by the exponents of classical culture, who denied that scientific training deserved even the name of education.

Professor Anthon, distinguished as a classical scholar and author, wrote in the '50's of the last century:

"We have great reason to be thankful that, amid all this ticketing of plants and minerals, this watching of retorts and crucibles, and all the other 'mind-developing' devices of a so-called 'practical' training, the claims of sound education are still listened to."

This elaborate sneer was rather mild as compared with many utterances of that day, both here and in England. Indeed, in the latter country there are today very many who are lamenting loudly the decay of the classical learning, though a closer examination of statistics shows that the decrease is but relative. There are more students, perhaps as many as ever are devoted to what our friend above calls "sound education," but the crowd of scientific seekers is so great as to make the friends of the older system appear less in number.

The other of these forces, instead of taking the position that technical education is "not education," asserted that it wasn't practical, hence that it was useless.

Leaving out of account the "classical" party, there are today two views entertained as to the best method to obtain success in technical occupations.

It may seem to some like "fighting a fog" to argue against rapidly vanishing prejudices. Nor shall we indeed devote any great space to the opponents of all kinds of scientific training.

The late Mr. Crane may be cited as representing one of these views, though his position was so extreme and his statistics so misleading that it seems hardly fair to his side of the question to quote him literally.

The general position is about this: "Science and theory are worse than useless in training a young man for practical work. The only way to learn anything in practice is to go at it in the field."

The other view hardly needs to be formulated. It finds expression in the existence of numerous and ever growing schools, institutes, and departments devoted to the teaching, whether in class or in the recently developed method of "correspondence," not only of the details of countless processes, but of the fundamental principles which underlie them, and which, whether correctly or erroneously, are supposed to be necessary for their intelligent practice.

Before we even justify the title of this series by explaining its relation to our theme, we shall devote a few lines to the consideration of some of the long familiar and, so to speak, "pet" assertions of the opponents of scientific preparation for technical work.

I shall cite no assertion or view that has not been presented to me personally during the many years in which I was engaged in technical education.

(1) "You can't make practical men in a school. You can't teach them how to meet men, nor handle employes."

Answer.—Nor how to choose a wife, or cook a beefsteak, nor sail a boat. How easy a thing it is to set up a man of straw and then demolish him! This tacit assumption that the institution pretends to do things which it never attempted, viz., training its students in the details of daily practice, is so old that it is rather wonderful that it has not died. Some wise man, however, has said that the older a fallacy, the tougher it is, and we believe he is very near to the truth.

What the school *does* attempt, comes later.

(2) "Your best students are never heard of after graduation. The leaders as students are the failures in active life."

Venerable old lie! How often we meet with you. We have had experience direct with nearly 300 graduates of one technical school, and we testify that the best men *in* the school were the best men *out* of it. The assertion is almost invariably made by those who confound the "college" with the technical institution, and as we are not discussing the former, we leave it to the college graduate to take it up if he cares to.

Any student of "human nature" will easily discern also, in this assertion, the elements both of ignorance and of envy.

The ranks of many professions are crowded today with the graduates of technical institutions. This is too well known to require proof. Ask them whether they regret their scientific course.

All of this is throwing words away so far as concerns any one who would make the assertion. He will always be found in the ranks of those who derive their facts from their imaginations.

We cannot pass over one phase of the development of technical education without some discussion. This is the comparative merits of the separated or special school, and the "Department" of a University course.

Later we take up the comparison already alluded to, of the correspondence school with the "regular."

So far as most universities in the United States are concerned it has been found exceedingly difficult to reconcile the "classical" with the "technical." Usually the latter has been the sufferer.

Here we meet so many differences in the details, no two institutions being quite alike, that we can only, if we want to compare cases, select one or two types.

First, then, the smaller college—whether it happens to call itself that or a "university"—has rarely or never separate facilities for its technical department. No matter. It calls it a "department" all the same. It organizes "courses" in the scientific lines. It establishes "degrees" with various alphabetical annexes. It has, let us say, a course in mineralogy, lectures attended by both "college" and "scientific" students. Finally, as is almost inevitably the case, its "applied science" is degraded to the college standard.

It may be no better when the "college" rises into the "university," though it certainly is in some cases. Cornell was perhaps the first university in the United States to make clear-cut and effective distinctions between the general and the engineering courses. By erecting separate buildings and appointing separate faculties, by segregating the departments physically as well as actually from the general course, this institution, many years ago, stood almost apart from the crowd. Another case was Columbia, where it was said that the tail wagged the dog, for its "School of Mines," by virtue of some of the conditions above enumerated, rose to be for many years better known than the parent institution.

But the rule has been and will be that the segregated institution (call it school, college, institute or what you will) that is devoted to a narrow line, will, by virtue of that very limitation in scope, accomplish better results in its own specialty than a "department."

We have already described the conditions under which this may prove not to be necessarily true, but they are exceptional. Some special cases we reserve for the last paragraphs of this topic. "Selective" courses, so temptingly set forth, and so alluring to hosts of

students, often prove to be "serap" courses. We are not using the word as an expression of contempt, but the phrase is too descriptive to be easily paraphrased. A "serap" course is one torn from its logical connections. It may start at a point which the student is not prepared for, it may stop (or the student may drop it) just as some application of its principles is about to be shown. In either case, or in cognate cases, the expression fits and such a course is directly opposed to our idea of "fundamentals."

In very many cases in the past, probably in many institutions in the present, these broken and incomplete courses become a necessity to the student who takes or tries to take a "mixed" course. Perhaps the rule has become less universal than it once was. We have recently seen too many examples, however, to doubt that the "schedules" are still the complex things they always were.

"Every student," we are told at one celebrated State University, "has to get his schedule from Professor Blank, and in fact no one else even attempts to regulate individual schedules or assign numerical credits." This remained something of a cryptogram to us until we investigated one case in detail. It was that of a young man who had secured credit for "one-third of a course" in mineralogy, and "one-fourth of a course" in chemistry. We did not know then, and do not know now, exactly what one-third of a course in anything is. We do know that these were broken, partial courses; schedules interfered and other matters came in. The wretched fractions nevertheless had to be credited, and as with the young man in question, so with many, many others.

These "numerical" bases for graduation credit have been discredited, and are unworthy of our age. They are not extinct, however. Perhaps they may be extended into physical makeup and moral character; for example, half a leg or one-sixth of a conscience.

Partial and illogical courses have always resulted when the attempt is made (and it very often is made) to join students representing different courses into one class in a given subject. No skill in schedule making will suffice to prevent interferences, broken courses, or sacrifices, often of matters "fundamentally" important.

It was in another university of no small repute, numbering, I believe, about 2,000 students, that we were shown the "working collection" in mineralogy. Now the point of this is that the work was all well enough on a college basis, but the students in this department were being assured that they were getting a "technical" knowledge of this science. The "working collection" was contained in one small cabinet and numbered some 200 specimens, all duly labeled. Instructors and students alike labored under the singular delusion that this was a "working" collection. We were so utterly amazed, chiefly because of the repute of the institution, that the instructor asked us what was the size of the "working collection" at the institution we represented, and upon being informed 36,000 and growing, he merely said that he could not understand how such a number could be used at all. Probably he would indeed have been as much at a loss as would have been those instructors used to a real "working" collection had they been called on to use his little specimen cabinet as a means of instruction in mineralogy.

We drop this detail of our topic chiefly because its main proposition will be so generally admitted that demonstration is hardly called for. "But," would say many of the defenders of department instruction, "you are too broadcast in your assertions. These defects were only too apparent a few years ago, but they are becoming obsolete with growth, and some departments in our universities are famed not only for equipment but for the records of their graduates."

We admit it. Cornell and Columbia have already been specified, and we regret that we cannot do justice to all the exceptions. Let us except mechanical engineering from our condemnation, in view of the pronounced success of Michigan and Wisconsin, and others. We cannot go into details, that is, the detailed enumeration of good and bad. We fear the bad are still too many, and are sure we have omitted to name many of the good.

The general proposition remains. An institution of narrow scope, viz., organized with but one course, or at most with two or three, with their corresponding degrees, can develop its aims with greater concentration of purpose. There are no conflicts in the departments, no struggles for supremacy between classical and scientific, which have taken place at far more institutions than are known to the general public. With "exceptions understood" the special school has turned out the best men in its specialty.

There will always be two schools of thought in the broadest sense, which we characterize as "conservative" and "progressive." We are not calling on the world at large to adopt the "progressive" set of ideas all at once. A meal eaten without appetite will not do much good, nor will the adoption of methods for which the recipient is not prepared. Nor will it do to say that because the ideas of the "conservative" of today are those of the "progressive" of 100 years ago, that conservatism may not be a necessary and sometimes even a useful force; for, notwithstanding its reverse direction, it is possible that at times a "pull-back" is needed for the prevention of ill-considered innovations.

In the tendency, too manifest to be seriously disputed, of the whole civilized world to accept both the objects and the methods of science, it must be understood that we mean science in the broadest sense, which means all "classified knowledge," and especially do we mean "scientific method."

That is an obsolete view of science which looks upon her function as a mere piling up of facts. It has been well said that she is the interpretation of nature, and that man should be the interpreter. Also, "as saith the poet," man should study himself, not so much sentimentally as scientifically, not only as an individual, but as a race. Some of the most beneficent results of modern knowledge, that is, results for the betterment of the race, have resulted from close and intelligent study of phenomena once thought to be too mysterious to come within human ken but now known to belong to the realm of science properly apprehended.

Why have we admitted "conservatism" as a useful force, while at the same time hoping for still further advances both in scientific knowledge and in scientific method?

Because the race learns slowly, and because the rate at which new ideas are presented may be faster than the capacity of the race to receive them. We are prone to believe that people at large are following intelligently all the advances of the day, until the rude shock of some preventable disaster or some outbreak of crass ignorance convinces us that there is a mass of old-time prejudice outstanding, whose inertia will long remain as a drag upon the efforts of those working for racial improvement.

In this scheme of nearly balanced forces—the conservative saying, "Let well alone, we have enough, we know enough," the progressive always pushing on, forever seeking and forever unsatisfied—the racial progress can hardly be greater than the excess of the general intelligence from year to year, over the "pull-back" of ignorance.

The ancient world most esteemed the man of closed mind. Today we say we most esteem the man of open mind. We mean that our advance guard does.

If you want to know anything of the rear guard, attend a meeting of your city council. Also you will learn something of the "closed mind."

To those who doubt scientific advance, education, and method, I would say, "take a glance backward." Certainly there has been no retrograde movement.

As surely there has always been resistance to every forward step. No less surely have science and its methods always won out in the end.

Is there no lesson in this? Those who are trying to evade the inevitable had better say at once, like the coon in that venerable story: "Don't shoot; I'll come down."

This brief "backward glance" has not been without purpose, we trust also not without result. We have shown that opposition to scientific methods is not only not new, but is a mere echo of long ago. What the conservative is still saying is "we got along once

without anything of the sort, and we could yet. If your scientific education is necessary, how did the world get along without it for thousands of years?"

Perhaps these questions were better left unanswered. However, we'll answer the last query, which is common enough in regard to many things other than educational.

The world got along because it was a very different world from the world of today. We sometimes hear it said "that it will never



FIG. 1. SETTLING POND DAM, LOW MOOR IRON CO.

change so long as human nature remains." The inference is always that "human nature" is something fixed and immutable as the "eternal rocks." This we deny. "Human nature" changes slowly, but it changes, and we firmly believe that it changes for the better. But we are not writing a "History of Civilization."

Coming from these rather broad and general topics to the concrete question, we are going to concede certain things to those who claim that preparatory technical education is a failure. There are the individuals on whom it would be largely thrown away. These may or may not achieve some measure of success in the field; it is safe to say that the majority would not. The number of "students" (usually miscalled such) who drop a technical course after some months or a year or two of trial, is very large. Most of them drop the career also.

We have had a good deal of acquaintance with many of the young men who dropped their courses in technology too early, but who appeared nevertheless in the field in some line or other. Genius will accomplish almost anything, and the few among those who were of that species were either doing well or had gone to the bad in dissipation, which appears to be one of the curses of genius. The rule was, however, that they were not doing nearly as well as graduates.

Another class whom I would be the last to discredit, is composed of young men who have had employment in subordinate positions, with little or no technical education for a start, and whose genius for business affairs and for practical management surmounts their disadvantages, and raises them into positions of responsibility.

Their natural capacity enables them to acquire the mastery of detail, they seize almost by instinct those lines for which they are best adapted.

These careers form the text and sermon of the numberless attacks on technical education. No matter if the vast majority of those now in successful practice were originally grounded in applicate science, the fact that certain men can overcome their handicap serves for the fallacious argument that no handicap existed.

So far, we have given a little history, and answered a few objections. In the next number will be some illustrations of what we conceive technical education should be in its first elements.

Brown Hematite Mining in Virginia

Methods of Mining Peculiarly Adapted to the Conditions Existing at Low Moor Mines

By Charlton Dixon*

While most brown iron ore in Virginia is won by open-cut mining, considerable is obtained by underground mining, particularly in the Low Moor mines.

Underground mining is carried on by means of shafts, slopes, and drifts. Shafts and slopes are often driven in the ore, but drifts at tippie height are driven from 100 to over 1,000 feet before the ore is reached, through material washed from the mountain sides, which offers no extraordinary difficulties. These openings are closely timbered, both top and side lagging being used in wet ground and also mud-sills in drifts.

When the ore is struck, the car level *a*, Figs. 4 and 5, is driven both directions in the ore, and upraises *b* on the foot-wall are made every 50 feet. These are cribbed and partitioned, one side is an ore chute, the other a man and timber way. Round timber is used from 3 inches to 6 inches in diameter. When a vertical height of 18 feet is reached above the floor of the level *a*, another level *c* is started in both directions. This is known as the 12-foot level. All the levels are driven 12 feet vertically apart.

The first upraise is pushed to daylight as expeditiously as possible for ventilation, also as an easier means of handling timber. It also serves, where the vertical angle is favorable, as an ore chute into which the surface ore may be dumped. This is known as "milling." The continuity of the chute where intersected by the levels is secured by close plank conduits reaching from the bottom of one section to the top of the other, leaving sufficient space, however, for dumping the ore from each level until other upraises can be used. As soon as the through upraise is finished all the levels may be turned almost simultaneously in both directions and pushed night and day, which is done in most cases. This develops ore very rapidly. While ore in one of the level headings is being loaded the other end is being drilled. The car level is timbered 7 feet high in the clear, 6 feet between collar notches, with about 6-inch batter to each leg. Sets with 4-foot centers are lagged with wood on top and



FIG. 2. JORDAN MINING CAMP, LOW MOOR IRON CO.

sides. Occasionally the side lagging can be dispensed with, but the top never. This timbering supports the 6-foot pillar between it and the 12-foot level.

The other levels are not so large, averaging a foot less all around. Wherever possible they are driven without timber, about 6 feet high, 5 feet wide, arched toward the top, but invariably it becomes necessary to timber them long before robbing commences.

*Mine Superintendent.

Suppose that there is height to the body of ore in which to drive eight levels at the beginning. Experience has proven that in a distance of 2,000 feet two of these will be pinched out on account of the car level rising 1:100; it is always two levels somewhere between

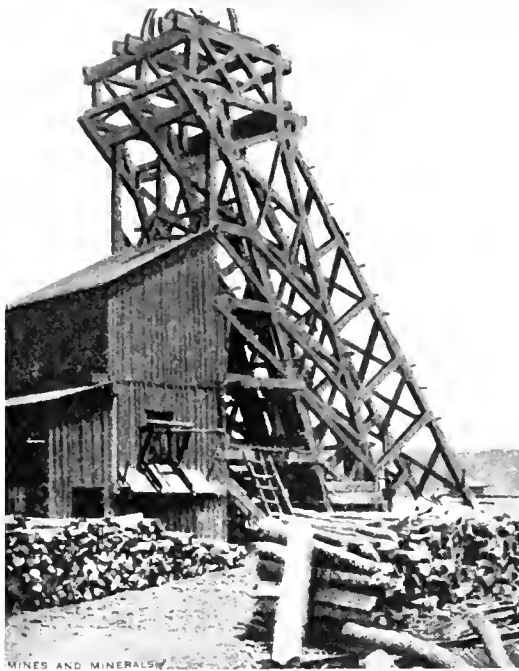

FIG. 3. HEAD-FRAME AT NO. 3 FENWICK MINE

the 12 and the 96-foot. The 12-foot level is always maintained as an airway for the main level. The upper level is driven to the end of the deposit and upraises are made at regular distances to test the height of the ore. The next level below the top level must be kept abreast for ventilation. All levels are driven as closely as possible to the foot-wall. The pitch and wall are very irregular, in fact there is no regularity or uniformity in either. At one point the ore can be chuted from top to bottom of the deposit; 50 feet away it may be, and often is, necessary to transfer two or three times to get the ore to the car level. The headings are supposed to merely keep in touch with the flint foot-wall, not to break into it and so foul the ore. This results in such contortions that it almost precludes the possibility of using any other means of transportation than the wheelbarrow. By the time the upper levels are ready to rob the car level is nearly completed and provides an outlet for the robbing. When ready the ore is attacked on both sides and worked off the foot-wall also back to the hanging. Usually the vein is about 12 feet thick. Long posts are set when required, temporary platforms erected, upon which the miners stand to work the ore from the hanging wall. Usually the outcrop part of the vein has been previously mined by open cut and the upper level carried as close as practical to daylight. The intervening pillar is from 15 feet to 20 feet thick. When a section has been thoroughly cleaned a floor is laid as follows: The ordinary timber set legs are placed at right angles to the level from hanging to foot-wall and from 4 feet to 6 feet apart. Across these parallel to the tunnel is laid what is known as 8-foot wood, which runs about 3 inches at the large end. The 4-foot wood taken from around the sets is also used. Another section is now started and worked in like manner. If the roof has not caved when there is 50 feet to 75 feet of gob, the 12-foot posts are blasted by boring into them and inserting a small piece of dynamite and firing it. Robbing can now be started in the next level below. This is proceeded with in the same way as described until a

part of the flooring above is detached; then the end of one of the carrying timbers is sought for and posted. The whole flooring is gradually exposed and supported by 12-foot stope props. Thus the floor with its burden is controlled until the ore is won. If after waiting a reasonable time for its caving it fails to do so, the same means are employed as in the previous case. Ninety-five per cent. of the ore is recovered by this system. It is peculiarly adapted to the conditions existing in the district, and it is susceptible to more modifications than have yet been exercised.

Its shortcomings as practiced at present are: (1) Necessity of driving the narrow work to the boundary before any robbing can be done; (2) the excessive amount of timber used; (3) loss caused by levels having to be retimbered while waiting to be robbed. Much of this by a change in the method can be avoided.

A great deal of carbon dioxide CO_2 is generated by the decaying timber; the heat evolved at the same time is often unbearable in the robbing rooms.

The introduction of carbide lamps (which burn brightly in an atmosphere entirely impossible to the ordinary oil lamp) increased the output from such places 30 per cent.

Drilling is done by Sullivan 2½-inch air drills. Black powder is used in open cut work; 40-per-cent. dynamite underground.

On account of soft seams in the ore a low tonnage is obtained per pound of explosive. A so-called expert was brought by one of the companies to correct this. After laying off a round of holes by rule he was astonished to find that an expenditure of 56 sticks (23 pounds) of dynamite, produced 1½ tons of ore. He also had certain theories as to system of mining, some of them were given a trial; the result was a heavy bill for the company. They were discarded after two months' probation. Due to the extreme irregularities of the deposit there is no mining anywhere that demands less theoretical knowledge or more practical ability than the brown-ore mining of Virginia. The most important mines of the region are the Jordan mines (all surface), Dolly Ann (underground), Fenwick (underground and surface), which are operated and owned by the Low Moor Iron Co., of Virginia. The largest single mine in the region is the Lignite mine at Oriskany (surface). This mine is in charge of J. W. Stull, a graduate of Virginia Polytechnic Institute, who, as an authority on brown ore, also on brown ore

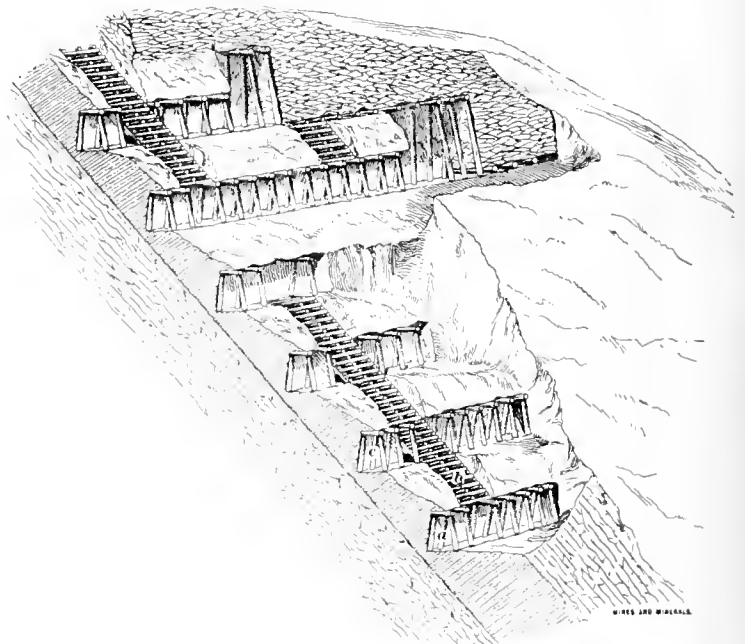

FIG. 4. PERSPECTIVE VIEW OF METHOD OF MINING

mining, has few equals and probably no superior in the state.

The sub-level and caving system of mining was first developed in the United States at Low Moor Iron Mines, and described in Transactions of the American Institute of Mining Engineers.

Homestake Employees Aid Fund

Results of the First Full Year's Experience as Shown by the Annual Report.

By Jesse Simmons *

In line with many other large employers, the Homestake Mining Co., at Lead, S. Dak., gives liberal support to an association called the "Homestake Employees Aid Fund." This is a benefit organization, paying indemnities for loss of life, disability, sickness, and injury. The monthly dues are much lower than in many other associations fostered by mining and industrial companies, and the benefits are even higher. Work in the mines of the Homestake company is not extra hazardous, and the climate is exceptionally healthful, so that mortality and sickness are by no means excessive.

The fund is supported by a monthly contribution of \$1 from each employe, and the company contributes \$1,000 each month. With an average of a little less than three thousand members, the monthly receipts are in the neighborhood of \$1,000. Upon death, either from accident, or illness contracted while in the employ of the company, or an accident causing total disability, such as the loss of both hands, both feet, or one hand and one foot, or both eyes, or partial paralysis, the aid fund pays \$800. For protection to itself, the rules of the fund specify that benefits will not be paid to employes for sickness contracted or accident suffered while in the employ of others than the Homestake company, or while on vacations. This applies also to death benefits.

For an accident resulting in partial disability, such as the loss of an eye, hand, or leg, the fund is drawn upon for \$400. In cases of suicide or insanity, the payment is \$200. For illness or accident causing the sufferer to absent himself from his work, he is paid \$1 per day for each day lost, not to exceed 6 months. The board of directors, however, may, at their discretion, consider disabilities due either to accident or sickness which continue beyond the time limit stated.

The control of the fund is vested in a board of five directors, consisting of W. S. O'Brien, general mine foreman; Dr. J. W. Freeman, chief surgeon; R. Blackstone, assistant superintendent; A. J. Clark, assayer; and J. A. Spargo, master mechanic. Under the rules governing the fund, the superintendent of the Homestake

The fund was organized and became operative on August 1, 1910, so that the report quoted below is the first covering a full year that has ever been made public.

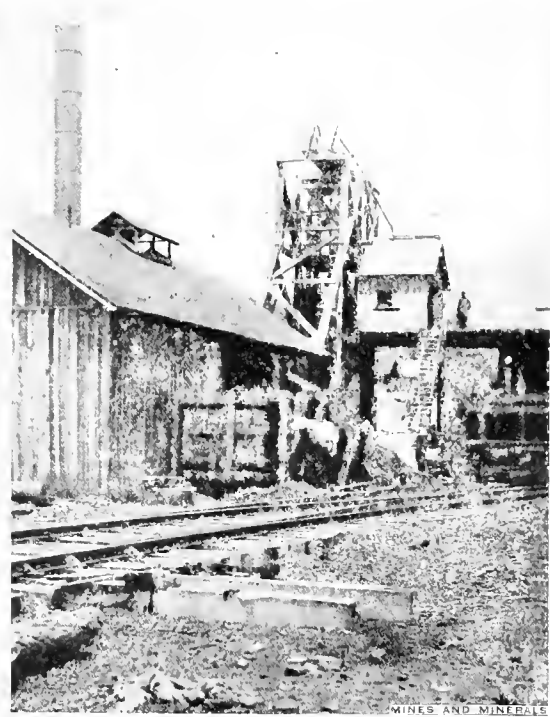

FIG. 6. HEAD-FRAME NO. 8, FENWICK MINE

During the year ending December 31, 1911, the following were the receipts:

Balance in treasury December 31, 1910.....	\$ 9,569.06
From employes.....	33,546.00
From Homestake Mining Co.....	12,000.00
From interest.....	224.00
From refund account overpayment.....	30.00
Total.....	\$55,369.06

Following were the disbursements for the same period:

Death benefits.....	\$20,000.00
Injury benefits.....	13,205.50
Sick benefits.....	7,277.25
Balance in treasury December 31, 1911.....	14,686.31
Total.....	\$55,369.06

In addition to the benefit fund above described, the Homestake Mining Co., and one of its largest stockholders, Mrs. Phoebe A. Hearst, maintain many institutions for the help, convenience, and comfort of the employes; among them a hospital, well equipped, and with a good staff, where medical and surgical treatment and medicines are furnished to the employes free of all charge. The company will build, in the spring, a club house for employes, costing, with furnishings and equipment, \$75,000, which will be maintained free of cost. This building will contain the many conveniences found in such places: reading rooms, gymnasium, assembly hall, baths, etc. Mrs. Hearst's gifts include a free library, which is well appointed and most liberally patronized, and a free kindergarten, operating during the summer months. Mrs. Hearst also mails each year a substantial check to each church in Lead.

來 來

Nickel-Zinc Alloys

Besides the compound, $NiZn_3$, already known, two new pounds of nickel and zinc are shown to exist, viz., $NiZn_4$ and Ni_2Zn . The $NiZn_4$ compound has been isolated as a crystalline, non-magnetic powder, with a specific gravity of 7.71. Its melting point is about $850^\circ C.$ —Bull. Soc. Chim., IX, 873.

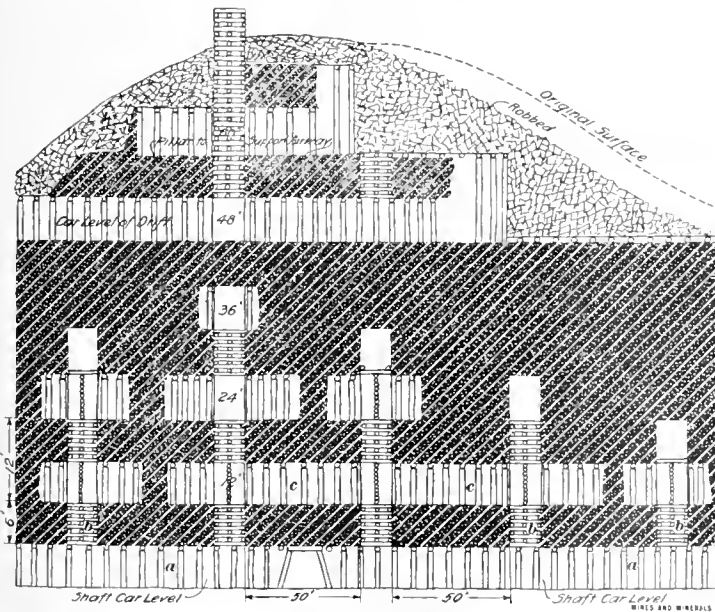

FIG. 5. ELEVATION, SHOWING METHOD OF MINING BY LOW MOOR IRON CO.

company, Mr. T. J. Grier, is treasurer of the fund. The company furnishes, without charge, such office room, stationery, and clerical help as is necessary to administer the fund.

* Deadwood, S. Dak.

Following the Ore in Joplin Mines

Methods Employed in the Sheet Ground, the Disseminated Ore, and the Soft Ground

By Lucius L. Wittich

To be able to "follow the ore" and to produce the maximum tonnage at the minimum cost are requirements of the mine superintendents and underground bosses of the Joplin, Mo., zinc and lead district. But owing to the peculiar formation of the deposits it is not always an easy thing to do, as is attested by the scores of mines that have been considered worked out, only to be rejuvenated. Scientific mine development has been discarded by the "old timers" and the primitive methods of mining have been adhered to.

Changed conditions during the past two decades have made it possible to handle low-grade material that would not have been considered of value in the early days. Increased prices for ore and decreased milling costs, coupled with the improved milling processes, have made it possible to treat dirt as low as 1 per cent. in blende, although the probable average of dirt for the entire district is about 3 per cent. ore, of which the greater proportion is blende and the remainder galena and calamine. Virtually everything taken from the mines (save in small rich gouges, where hand sorting is followed) is milled or treated on hand jigs. The tonnage of milled ore is far in excess of that from the hand jigs, and the proportion of milled concentrates is increasing much more rapidly than those from the hand jigs.

Why it is possible to reopen old mines and work them at a profit on thinner dirt than was formerly produced, is explained when it is considered that the average price of blende in 1901 was \$24.21, while today it is in excess of \$40. This comparison gives a fair idea of the wide difference of prices, and by going back farther it is found that the price of blende was much lower than this. Twenty-five years ago a liberal price for the best grade of blende was \$18 a ton, while the average fell far below this figure. It was necessary for the miner, therefore, to work only the richest deposits to reap a profit. The price of zinc ore was the all-important item; lead ore was not then, and is not now, produced in sufficient tonnage to cause a great difference in the district's prosperity, regardless of whether the price be high or low.

How the earliest miners worked may be seen by visiting some of the numerous open-pit mines. At the property of the Brand-

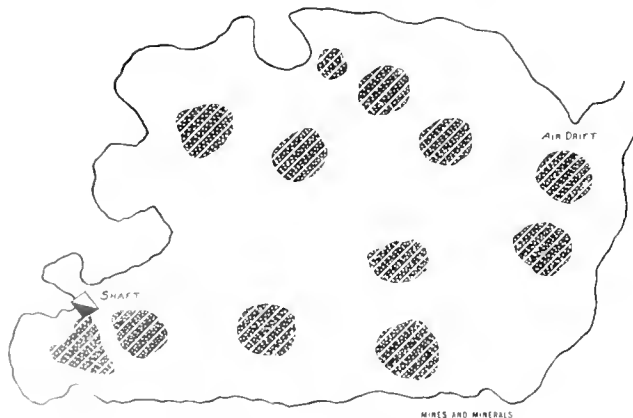

FIG. 1. MAP OF MISSOURI BLANKET VEIN AT CARTERVILLE, MO.

ford-Kansas City Co., at Webb City, Mo., a vast pit, more than 110 feet in depth, and 200 feet across, opens to the surface. In the side of this chasm, and within 20 or 30 feet of the surface a number of drifts, barely large enough for a man to enter, open on the precipitous walls of the pit. They tell the story of the early gouging where the richest ore streaks winding like snakes, were followed. As development progressed and mining became deeper,

more and more ground was cut from beneath the original drifts, and eventually the ground caved, leaving exposed the locations of the primitive passageways.

Royalty also plays its part in determining the nature of the mining development. If the leasing company asks excessive royalty from the operators the latter are not in position to work the ore deposits as thoroughly as they would with lower royalty. Roy-

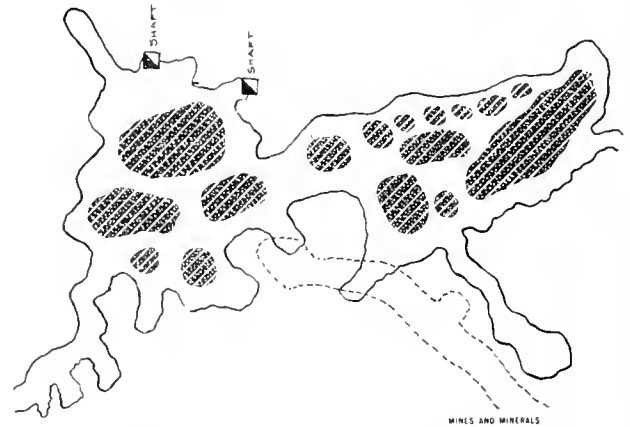

FIG. 2. METHODS OF DRIFTING IN DISSEMINATED ORE

alties range from 5 per cent. up to 50 per cent., the probable average being 15 per cent.

In sheet ground where the blende and galena occur in a formation of a prevailing thickness, the problem of following the ore is simple, because the blende is almost everywhere in sufficient quantities to be worked at a profit when a large tonnage can be handled, with the price above \$40 a ton, and the royalty not excessive. In sheet ground some layers of ore are richer than others. The entire ore bearing stratum may be 10 feet in thickness, or more, yet it may not be policy to mine this entire stratum, as one portion of the ore body is richer than another. Just how high or how low to cut into the lean ore, and yet keep the general average of blende and galena at a profitable figure, is a problem that continuously confronts the operator. A reproduced map of the Missouri Blanket Vein mine at Carterville, Mo., the first sheet ground mine opened in the district is shown in Fig. 1. The possibility of profitably working the low-grade rock was then an unsettled question. That sheet-ground ores have since represented more than 60 per cent. of the entire output of the district indicates that operators have found this form of mining profitable. The figure shows how the pillars have been left indiscriminately, probably representing areas of unusually lean ore. Where possible, it is policy to leave the pillars in sheet ground in the form of the five spots on a dice. In other words, the drift should be split every time when leaving pillars.

In the disseminated ore formations, the task of confining the development to the mineralized zone is somewhat more difficult than in sheet-ground mining, due to ore being in pockets, which, however, in many instances, are so extensive they afford scope for mining for long periods. This diagram, Fig. 2, was taken from a map and shows the methods of drifting at the Kansas Mining Co.'s mine at Miami, Okla. It will be observed that pillars are left much closer together than in the sheet-ground workings.

Fig. 3 affords a most interesting study of the eccentricities of the average soft-ground formation. At the 66-foot level there is a network of drifts; then again at the 94-foot level there is another set of drifts. The shaded portions indicate caves where the upper drift has either fallen into the lower one, or where the ground has gone down from the surface. This is reproduced from a map of the New Dividend Mining Co.'s workings, made before the entire south workings caved in from the surface. The pillars are so extensive that they form large areas of ground, presumably devoid of mineral or containing it in such small quantities that it could not be mined at a profit. The drifts follow the workable deposits, and from the map it is easily seen how scientific methods would have availed

little in mining the ground. What was needed in this instance was a man thoroughly in touch with geological conditions and one who knew how to keep his headings in ore and how to timber his drifts so they would not cave in. In the sheet-ground mines and in virtually all of the disseminated mines little or no timbering is required, while in the extremely soft-ground workings supports of timber are needed.

Caves as the result of improper timbering are common throughout the district, and it is not uncommon for large companies to take over such propositions, where the ore is found at shallow depths, and work the mine from the surface down, milling everything that is taken out. Where such operations are conducted on an extensive scale, extremely lean dirt may be worked profitably. In Fig. 4 is shown an opening into one of the numerous drifts, all connected, on the Missouri Lead and Zinc Co.'s land at Joplin. The area of worked ground in the vicinity of this pit may be appreciated when it is explained that the pumping arrangements shown were conducted with the view of lowering the water to a point permitting the recovery of the body of a boy who had drowned while swimming in the pond, and that it required the steady operations of six centrifugal pumps, each with a capacity of 1,500 gallons per minute, for four days before the water was lowered to a depth of 30 feet. At this rate, 12,960,000 gallons of water were pumped daily from a pond which looked as though it should have been emptied in a few hours.

Virtually all of the richer deposits of both zinc and lead ores of the Joplin district occur in the Keokuk and Burlington horizons of the Mississippian series, although a thinly disseminated blende is encountered at points in the underlying strata of Kinderhook. Some ore is found in the Des Moines horizon of the Pennsylvanian series, overlying the Mississippian. As the ore deposits result from the gravitation of solutions from the overlying Pennsylvanian into the Mississippian, where the mineral was deposited, the physical features are often fantastic. It is commonly recognized that the zinc and lead once held in the Pennsylvanian, descended as the shales and limestones of the series were eroded and became disintegrated, being carried away eventually and leaving the Mississippian exposed. The Pennsylvanian, which once covered the entire western portion of the Ozark dome, is now quite well defined

by the course of Spring River, the Mississippian outcropping on the east of the river, where it flows through eastern Kansas, and the Pennsylvanian beginning on the west and gradually increasing in thickness as it dips toward the west.

The organic matter responsible for the coloring of the chert beds was derived from bituminous shales, the downward circulation carrying it into the broken chert beds and masses of chert conglomerate. Silica, either in suspension or solution, was probably contained in the downward circulating waters and with it evidently was carried fine carbonaceous or asphaltic material, both of which were plentiful in the shales.

While limestone is the country rock throughout the entire zinc and lead district, the chief deposits occur in flint or chert, brecciated

to such a degree that they afforded free drainage channels for the ore-laden waters from above, and the deposition of the mineral salts naturally took place more extensively in such areas. Early operators regarded surface indications as of great importance in the location of ore deposits. Iron pyrite, being one of the more common accessory metallic minerals found with blende deposits, a rusty tinge from oxidized pyrite on the outcropping flint was regarded as an encouraging indication of blende. On such indications many mines were launched. The portable drill rig of the Keystone type has eliminated much of the guesswork, yet drilling is not universally a success. Not long since

Joseph Clary, a miner, was imprisoned in a drift of the White Oak mine, near Joplin, by caving ground. It was known that the narrow drift in which he was confined ran in a southeasterly direction from the shaft, that it was 10 feet wide and possibly 60 feet long; to afford him ventilation a drill was set to work in the hope of penetrating the drift, but as a result of miscalculations four holes were required before this drift was tapped. Presuming the drift to have been a body of rich ore, it is easily seen how holes might have been drilled and how the mineralized portion might have been missed each time.

That the ore "is where it is" is a common expression among prospectors; although in recent years the value of a thorough knowledge of geology is beginning to be appreciated. For instance, a peculiar formation, the Short Creek oolite, a limestone composed of granules resembling fish eggs, is almost invariably encountered

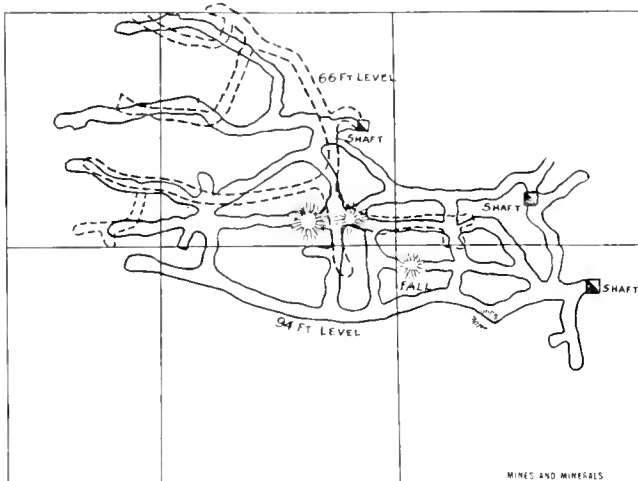

FIG. 3. SOFT GROUND MINE



FIG. 4. RESULT OF INDISCREET DRIFTING

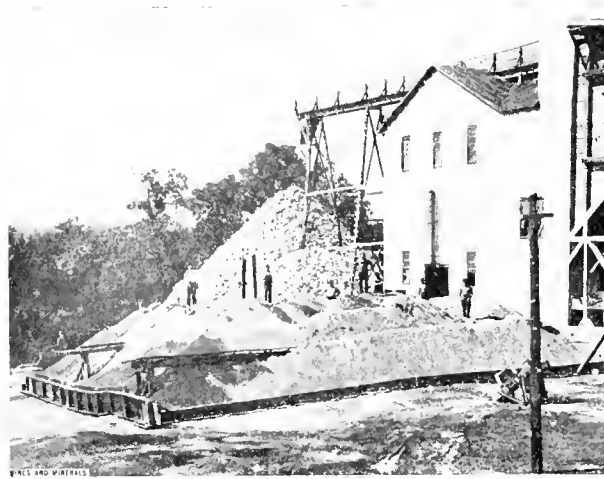

FIG. 5. PILE OF ZINC ORE CONTAINING 3,200 TONS

about 100 feet above the Grand Falls chert, the chief ore-bearing horizon of the sheet-ground districts.

The flint or chert because of the fact that it carries most of the ore mined, is the more interesting and important rock. The chert is found in two distinct types, the primary chert and the secondary. Geologists say the primary chert was formed before the ore. The secondary chert was formed after or simultaneously with the ore.

Indications are that the primary chert was formed simultaneously with the limestone and with this stone it is interbedded. At other points the chert will be found in great masses, cutting across the bedding planes and extending downward for hundreds of feet from the surface. At one point in Kansas, according to Haworth, the chert was encountered for a depth of 1,000 feet.

The lines of demarcation between the limestone beds and the chert areas are often difficult to determine, due to their overlapping in long, finger-like projections of one stone extending deep into the mass of the other.

In the fissures of the primary chert the secondary chert is deposited, the two being cemented together. The secondary flint of variable composition, is charged with different varieties of both zinc and lead and other material. Sometimes it is almost pure silica. Again the pure blende crystals may act as the cementing material in the fissures of the primary chert. The color of the blende



FIG. 6. CALCITE CRYSTALS

varies from a pale yellow in the best ore to a black in the poorest ore. Calcite crystals, Fig. 6, frequently occur in conjunction with the ore deposits, lead and zinc cubes and crystals being attached to the edges of the calcite.

"Shines" were considered of more importance in the early days than now; that is, the prospectors who depended exclusively on shaft sinking and drifting and who had not yet brought the churn drill into general usage considered a few small pebbles or streaks of zinc or lead as of great importance. H. H. Gregg, governor of the Southwestern Zinc and Lead Chapter of the American Mining Congress, relates the history of the development of the one-time famous Tanyard Hollow mine.

"The mine was discovered through the fact that a strip of outcropping flint carried iron rust stains. On the strength of this indication we sank a shaft and at a depth of about 40 or 50 feet came on to a few little shines that a modern day operator would pay little attention to. But in those days the shallow, rich pockets were sought. The deeper ore runs had not yet been discovered. Today if a drill should penetrate such lean dirt on a similar depth, it would not be considered in the nature of a strike; but in the days of the Tanyard Hollow mine the custom of following the dim trails was popular, and instead of sinking deeper we drifted and that first drift wound through the flinty mass until a shot in the heading brought down an avalanche of sparkling zinc crystals. We had followed the 'feeder' to one of several ore pockets. The dirt carried 20 per cent. ore, which was treated on hand jigs, and the weekly output of concentrate was heavier than now made from many of the mills—but zinc ore in those days brought only \$20 a ton."

Beyond a doubt many rich shallow ore deposits remain untouched. Periodically, reports of rich strikes are heard, and in many cases such strikes are made near some old-time mine that was thought to have been worked out.

In following the ore, the pay dirt may suddenly "pinch out." In some freak of formation it may have dipped suddenly, or may have risen; it may have swerved to the right or to the left, and the continuation of the rich dirt may be found beyond a comparatively thin shell of intervening rock. Of course this probability, in sheet-ground mining is reduced to a minimum, but in all other classes of mining the large producer of today may be barren tomorrow, and it is because of this probability that it is wisdom on the operating company's part to keep its ground prospected in order to drive into ore-bearing ground when pockets being worked are exhausted. For the purpose of keeping the ore pockets well defined the churn drill is a big asset, even although the ore formations show a tendency to be bunched in small pockets.

Drifting is not an uncommon method of prospecting when the operator feels that pockets of ore may be discovered to the right or to the left of the ground being mined. Winzes are sunk in the floors when there is a possibility of ore, and upraises may be made in the roof. Where careful record of all ground work is kept it is customary to note the richness of the dirt in the various headings, and to keep this record so complete that it shows when and where the ground becomes richer or poorer.

A glaring fault throughout the district, especially on the part of those who are possessed of the desire to get rich quick, is the practice of mining out the rich ore and leaving the lower grade; for it often happens that caving ground will prevent the mining of the larger body of low-grade ore, which, had common judgment been used, could have been milled at a profit. In soft-ground mining it is necessary, frequently, to leave pillars of ore with the view of removing them later. Before they are removed the operators should be satisfied that the mine has been worked out, for after they are drawn the chances are that the ground will cave.

At the H. L. Kramer mines three methods of prospecting are followed. In the deeper ground the company keeps two drills at work and although the ground is lean it has been profitable to work by large milling operations and by keeping the mine in condition to supply enough ore to keep the mill going continuously. In the shallower ground the company employs shaft-sinking methods successfully, connecting these shallow shafts with the mill by long tramways. Prospect drifts from the shallow shafts, are also used in keeping the ore bodies defined. In Fig. 5 is shown 3,200 tons of blende concentrate cleaned from dirt that would not average more than 2 per cent. blende. This was the largest single accumulation of zinc ore in the history of the district.

Gradually, as milling methods are improved, mining methods are altered. It is no longer imperative to follow the rich ore runs as closely as formerly. The possibility of mining 1 per cent. dirt at a profit is now a reality, and with this possibility the field of mine development is broadened.

采 采

Radium in Australia

The United States Consul at Sydney, Australia, states that a South Australian geologist has submitted a report to the Commissioner of Crown Lands, in Adelaide, on the occurrence of uranium ores in a new mining field known as Yudanamutama, in the northern district of South Australia, near the Queensland border. The chief formation is a lode 3 miles in length, and it is this which carries uranium minerals at intervals. A prospecting company has been formed in Adelaide, and a good deal of development work has already been accomplished. This report deals in detail with the ore found in each of the workings and states that several localities have already been discovered within a radius of a few miles, and others will, in all probability, be found by further testing. The presence of ores carrying niobium, monazite, and other rare metals associated with the uranium ores in some of the localities adds value to these discoveries.

Sintering Fine Iron-Bearing Materials

Method for Cheaply Preparing Dusts and Fine Concentrates for Treatment in Blast Furnaces

By James Gayley, New York, N. Y.

The following is abstracted from a paper presented at the Wilkes-Barre meeting of the American Institute of Mining Engineers, June, 1911:

The waste of iron ore through the production of flue dust has increased at an enormous rate, and only in recent years has a possible future value been recognized and the material stored. The amount of flue dust carried out of the furnace depends on the fineness of the material and the velocity of the gases. Attempts to recover a part of this loss have been made by recharging a portion of the production into the furnace.

There are deposits of magnetic iron ores in the United States and Canada too low in iron for use at the present time, but which can be economically concentrated into rich material; in many cases the fineness of crushing necessary to secure proper concentration has prevented their use except in extremely limited quantities.

The Dwight & Lloyd system of sintering fine material in thin layers promises to solve this problem most efficiently. As shown in Fig. 1, the machine consists of a steel frame supporting a sheet-iron suction box *g*, open at the top, over which may be pushed a train of conveyer elements *a* called "pallets," each of which has a floor composed of ordinary herring-bone grates, and which slides on its planed bottom, making an air-tight joint with the horizontal top edges of the suction box on which it rests. The vertical surfaces of contact of the pallets with each other are also accurately planed, so that all joints are closed air-tight when the train of pallets is being pushed along.

An exhaust fan connected with the suction box by pipe *f* induces air-currents to travel downward through the openings in the pallet grates and through the permeable material resting upon them. To trap the air properly, a smooth-surfaced dead plate, somewhat longer than one pallet length, is bolted to each end of the suction box.

The movement of the train of pallets is accomplished by a pair of cast-steel sprocket wheels *e* which serve the double purpose of lifting the pallets from the lower level and pushing them horizontally across the suction box. Each pallet is provided with four small roller wheels which hang idle while the pallet is traveling over the suction box, but serve to carry the pallet on its return trip to the point of beginning. The return of the pallets is provided for by a pair of semicircular discharge guides, terminating in a lower track way sloping downward to the base of the main sprocket wheels, and continuing as semicircular guides around their peripheries. The pallets when they complete their journey across the suction box to the point of discharge have their wheels engaged by the curved guides, and when pushed still farther, beyond the crest of the curve, break away from the train that is pushing them and one by one drop with a sharp blow on the upturned edge of the pallet just preceding. This shock serves to dislodge the cake of sinter from the surface of the grates, which

now stand more or less vertical. The train of discharged pallets in the guides and on the inclined lower track way, crowds down by its own weight to the foot of the main sprocket wheel. During this period of their travel the pallets are upside down, which automatically tends to clean out the grate slots. The sprocket wheel lifts the train of pallets to the upper level and the cycle is completed.

We thus have a practically endless conveyer, any individual element of which can be removed for repairs and a new one substituted without stopping. The circuit may, if desired, be made a closed one, and this arrangement has been used under special conditions; but, in general, it is customary to leave an interval in the train of about one and a half pallet lengths, which gives just about the right amount of shock.

The speed of horizontal travel of the pallets is adjustable to meet varying requirements, with the usual range from 7 to 30 inches of linear travel per minute.

The ore charge is automatically fed to the pallets in a thin layer (from 4 to 6 inches thick) from a simple funnel-shaped hopper *d* of the same width as the pallets hung directly over them at a point between the main sprocket wheels and the suction box. There being no bottom to the hopper, the material rests directly on the

pallets and is dragged out by their movement, the front edge of the hopper acting as a scraper to form a uniform layer of the proper thickness.

The stream of ore emerging from the hopper passes under an igniting device *i* which kindles the combustible elements in the charge on its top surface, and the combustion thus started is carried downward through the mass by the air-currents while the material is passing over the suction box. This ignition can be accomplished by almost any kind of flame that will give a quick, intense heat. The wide variety of suitable means makes it possible to meet almost any local requirements.

The complete cycle of operations is as follows: A pallet being pushed outward tangentially from the top of the sprocket wheels, passes under the feed-hopper, where it takes its load of ore in the form of a continuous even layer of charge, say 4 inches thick. It next passes under the ignition, where the top surface is ignited, and at the same time the charge comes within the influence of the down draft induced by the exhaust fan through the suction box. The air-currents promote rapid combustion of the fuel in the charge and carry the action progressively downward from the top until it reaches the grates. This developed heat and the chemical reactions consequent thereto serve to bind the mass together until it becomes a coherent cake of cellular material, much resembling coke. The speed of the machine should be regulated so that the combustion and sintering operation is complete when a given pallet has reached the far end of the suction box, where the cake is discharged by the pallet dropping into the discharge guides and striking the one just preceding it. The empty pallets then gradually crowd back to the face of the sprocket wheels, are slowly raised to the upper track, take their load, and make a new trip.

The area of the suction box is the measure of the capacity of the machine, and the suction fan must be proportioned to maintain a vacuum of about 6 inches when handling approximately 4,000 cubic feet of gases per minute, this being the average volume from each 100-ton unit.

Such a fan, with short and straight pipes and running at about

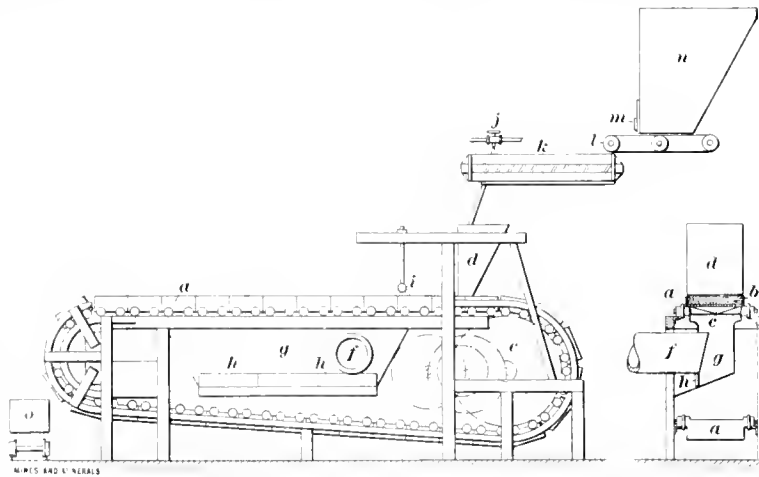

FIG. 1. LONGITUDINAL AND CROSS SECTION OF SINTERING MACHINE

n, ore bin; *m*, feed regulating gate; *l*, feed belt; *k*, mixer; *i*, water spray; *d*, feed hopper; *i*, igniting burner pipe; *a*, pallets; *g*, wind box; *h*, cleaning doors; *f*, suction pipe to fan; *e*, sprocket wheels; *o*, car

850 revolutions per minute, requires from 25 to 35 horsepower. The sintering machine itself consumes about 1.5 horsepower, but 10 horsepower is usually allowed for machine, conveyers, feeds, and mixers—in fact, everything except the fan.

Each sintering unit occupies space approximately as follows: 30"×150" machine (so-called 50-ton unit): Length over all, 27 feet; width over all, 7 feet; height of top hopper above foundation, 11 feet 4 inches; units in battery may be set with 11-foot centers; weight of complete machine, approximately 16 tons. 42"×264" machine (so-called 100-ton unit): Length over all, 40 feet 8 inches; width over all, 7 feet 6 inches; height of top of hopper above foundation, 13 feet 9.5 inches; units in battery may be set with centers 12 to 14 feet apart; weight of complete machine, approximately 26 tons.

The heat developed in the operation, being internal to the ore mass, does not cause the pallets to become very hot; moreover, on account of the slow movement of the mechanism, the wear and tear is very small, and 5 cents per ton will easily cover all ordinary contingencies.

TABLE 1

Sample	Fe Per Cent.	P Per Cent.	Mn Per Cent.	SiO ₂ Per Cent.	Al ₂ O ₃ Per Cent.	CaO Per Cent.	MgO Per Cent.	Car- bon Per Cent.
No. 1. Flue dust.....	46.06	.194	.54	9.68	3.00	1.80	.80	17.00
Sintered product.....	57.96	.260	.66	12.30	3.95	2.00	1.20	.60
No. 2. Flue dust.....	46.43	.123	.60	9.88	2.72	2.00	1.44	13.75
Sintered product.....	58.84	.150	.75	11.81	3.05	2.50	1.71	2.10
Magnetic concentrates.....	57.52	.090	.56	9.70	3.43	.35	.10	.10
Sintered product.....	59.65	.110	.60	10.60	4.00	.30	.10	

SULPHUR

	Per Cent.
Magnetic concentrates with 7 per cent. of coal.....	1.170
Sintered concentrates.....	.006

SIEVE TEST

Sieve	No. 1 Flue Dust Per Cent.	No. 2 Flue Dust Per Cent.	Magnetic Concentrates Per Cent.
On 10 mesh.....	14	4	28
On 20 mesh.....	31	1	44
On 40 mesh.....	31	6	15
On 60 mesh.....	14	4	7
On 80 mesh.....	3	15	2
On 100 mesh.....	3	20	1
Through 100 mesh.....	4	50	3

	Ferrous Iron Per Cent.	Ferric Iron Per Cent.	Total Iron Per Cent.
Cuban (Mayari) ore (dried at 212°)	.63	47.80	48.43
Sintered product.....	9.67	44.30	53.97

SIEVE TEST, MAYARI ORE, SINTERED

	Per Cent.
On 2 mesh.....	53.88
On 4 mesh.....	16.33
On 8 mesh.....	23.35
On 20 mesh.....	4.33
On 40 mesh.....	1.12
On 60 mesh.....	.51
On 80 mesh.....	.02
On 100 mesh.....	.14
Through 100 mesh.....	.32

A number of iron-bearing materials of different kinds were treated on this machine, and in each case with satisfactory results. The sintered product of each was ideal in size and structure for the blast furnace; the individual pieces were cellular, like pumice stone or porous cinder, which helps materially toward economic reduction in the furnace, as a large area of contact is provided between the ore and gases.

In sintering materials which do not contain any heat-producing substances, recourse can be had to the practice of the ancient Catalan, or Corsican, process, where carbon fuel was mixed with

the ore, and which, in its first stage, was an agglutinating process. In order to test the machine on this class of work, some magnetic concentrate was treated after being mixed with 7 per cent. of coal, and the product was found to be satisfactory in every particular. The material was sintered into a coherent mass, but so open and cellular in structure that the mass, in discharging from the pallets, broke into very convenient sizes for the furnace, and without any fines. As the mixture contained less carbon than the flue dust, it was sintered much more quickly. While in the test on flue dust a travel of 12 feet in the grate movement was required to complete the sintering, the concentrate was completed in a travel of 6 feet.

Table 1 gives analyses of the material treated.

The physical structure of the sintered product varies. Where there is a large amount of moisture and carbonaceous matter present, a corresponding shrinkage within the mass must take place, as the volatile constituents are driven out, and this may cause the cake of sinter as a whole to break up into irregular-shaped masses or fingers. The smallest of these pieces, however, has a cellular structure like pop corn. In the case of magnetite concentrate, where there is less internal shrinkage, the sinter comes off in slabs having an open structure.

The Cuban ore being the finest, the sinter was of a smaller average size than the magnetic concentrates, which were coarser and did not shrink so much in sintering. The flue dust being coarser than the Cuban ore produced a sinter about midway in size between the flue dust and the concentrate. The cohesiveness of the material is inversely as the amount of internal shrinking of the mass during sintering.

來 來

A Pulverizer for Assayers

An efficient, simple, and durable fine grinder for assayers, has recently been devised for which applications for patents on the machine, its disks, and parts are pending.

This machine has been thoroughly tested and has been found capable of grinding a sample of either hard or soft ore to a very fine mesh in remarkably short time. It is very easily cleaned, is practically noiseless in operation, and does not require much power.

The grinding is accomplished by a compound movement between two plane disks, one being stationary, and the other having a double movement—a revolution on its own shaft, and an eccentric rotation due to the revolution of a hollow shaft in which the disk shaft has an eccentric journal. This produces a rubbing action which reduces the ore quickly and prevents corrugation on the disks, so that they are in perfect grinding condition until worn out. The disks, which are made of a composition which gives the greatest durability consistent with rapid grinding, are the only wearing parts necessary to replace, are inexpensive and can be changed in less than two minutes. The rotating disk is attached to its shaft so that it is free to adjust itself to the plane of the stationary disk, and thus it always is in position for proper grinding. A ball and socket joint takes the thrust of the grinding. Adjustments for fineness of grinding are made by turning a hand wheel which automatically locks in position.

The machine is opened and closed by one movement of a lever cam clamp. The sample drawer is attached to the front case, which is hinged, and substances adhering to the case or stationary disk may be brushed into the pan. The gears run noiselessly in oil in a closed chamber.

Two sizes of the machine have been made, one 30 in. ×11½ in. ×11 in. and weighing 330 pounds, and the other 34 in. ×20 in. ×15 in., weighing 510 pounds. This smaller machine requires 1 horsepower, and will reduce an 8-ounce sample of any ore from ¼ inch to 100 mesh in 30 seconds, and the larger machine will reduce a similar sample weighing 1 pound to the same degree of fineness in the same time.

Mechanical Drying Furnaces

Different Forms Required According to the Nature of the Materials to Be Dried

By John S. Nicholl*

While drying has long been practiced in certain metallurgical and manufacturing processes it is only during comparatively recent years that the engineer has studied the subject and designed driers that are highly efficient and represent the best mechanical structure suitable for the specific purpose. Without attempting to enumerate reasons for the slow development, it may at least be correctly said that the latest stimulant toward the perfection of the design of driers has been largely the increased demand caused by such rising industries as the cement, asbestos, plaster, gypsum, magnetic separation of minerals, etc., and also because of the large variety of substances which were formerly wasted but are now dried and sold for various uses.

With the exception of those directly concerned in industries where driers are used, it is quite safe to say that the majority of engineers are unaware that materials of different physical and chemical properties demand different kinds of drying apparatus. An expert on this subject of drying gives the following classification:

Group A. Materials which may be heated to a high temperature and are not injured by being in contact with products of combustion. These include cement rock, sand, gravel, granulated slag, clay, marl, chalk, ore, graphite, asbestos, phosphate rock, slacked lime, etc.

Group B. Materials such as will not be injured by the products of combustion, but cannot be raised to a high temperature on account of driving off water or crystallization, breaking up chemical combinations, or on account of danger from ignition. Included in these are gypsum, fluorspar, iron pyrites, coal, coke, lignite, sawdust, leather scraps, cork chips, tobacco stems, fish scraps, tankage, peat, etc.

Group C. Materials which are not injured by a high temperature, but which cannot be allowed to come in contact with products of combustion. These are kaolin, ocher, and other pigments, fuller's earth, which is to be used in filtering vegetable or animal

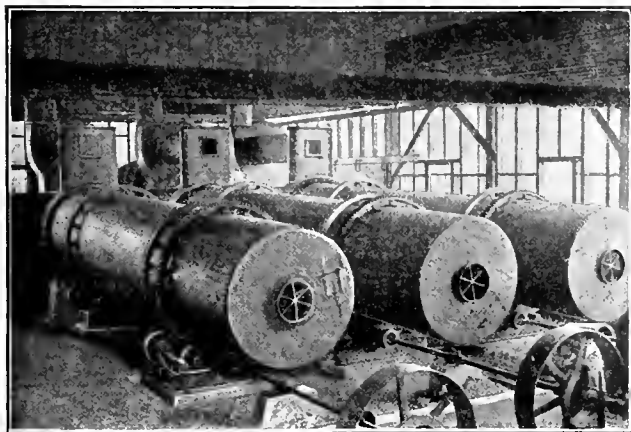

FIG. 1. ROTARY DOUBLE-SHELL DRYER, OUTSIDE

oils, whiting and similar earthy materials, a large proportion of which would be lost as dust in direct heat drying.

Group D. Organic materials which are used as food, either by man or the lower animals, such as grain which has been wet, cotton seed, starch feed, corn germs, brewers' grains, and breakfast foods, which must be dried after cooking.

Group E. Materials which are composed wholly of, or contain a large proportion of, soluble salts, such as nitrate of soda, nitrate of potash, carbonates of soda, or potash, etc.

Of course the simplest form of machine for drying materials of Group A is a single revolving shell equipped with lifting flights on the inside, and having a furnace at one end and a fan at the other end; but the heavy expense of upkeep and its low efficiency, due to radiation and the high temperature of the stack gases, make it absolutely impracticable. The excessive fuel consumption of this type is decreased when the shell is protected by brickwork and the hot gases pass under and back through it. The most efficient

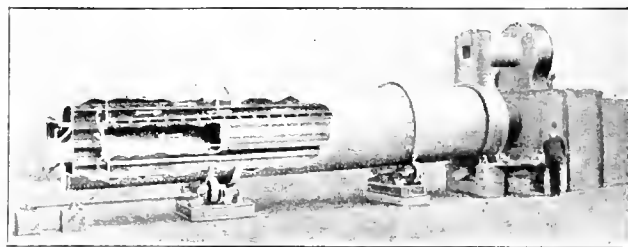

FIG. 2. DOUBLE-SHELL DRYER, INSIDE

dryer for this group is such as that made by the Ruggles-Coles Engineering Co., which consists of two concentric shells of steel, resting on eight bearing wheels and driven by a heavy cast gear located between the two tires. The gases pass through the inner shell at the feed end and back over the material, which is fed into the space at the same end where lifting buckets pick it up and drop it on to the inner shell. By revolving the machine the material is then dropped on the outer shell and this operation continues until it reaches, due to the inclination of the drier, the discharge end. It is quite evident that this procedure reduces the causes of losses in efficiency, which are unconsumed carbon due to imperfect combustion of fuel, heat carried away by exhaust gases, radiation from furnace and shell and the sensible heat carried away with the dried material. The long central flue in this drier acts as a large combustion chamber in which space and time are given for the perfect combination of oxygen and carbon monoxide. When a drier is arranged so that the flames impinge directly upon a cascade of cold and wet material they are quenched suddenly and a considerable amount of carbon passes off unconsumed. In single-shell driers, where this commonly takes place, incomplete combustion is the result.

As the gases travel twice the length of the shell in a double-shell drier and pass back and through the cold and wet material practically all of the heat is given up with a resulting exhaust temperature of 100° F. The gases are drawn through by an exhaust fan and the quantity regulated exactly to requirements. In the old types of single-shell driers a stack is almost universally used to carry off the products of combustion, and in order to get a sufficient draft to burn the necessary amount of fuel, a temperature of about 500° F. is required. It is quite readily seen that a drier which utilizes the 1,200 degrees of heat between 1,300° and 100° is practically 50 per cent. more efficient than one which utilizes the 800 degrees between 1,300° and 500°.

Inasmuch as the temperature of the gases in the double-shell drier when they reach the outer shell is approximately 200° F., and they pass out at 100°, the average temperature of the outer shell is not over 150°. In the single-shell driers the heated gases come in direct contact with the shell and it is not unusual to see that red hot for one-third its length, which causes not only loss by radiated heat but makes it difficult to operate them.

For drying materials of Group B the single-shell drier may be used and in some cases a bricked-in machine, but none of them are dried in a satisfactory way on account of the difficulty of regulating the temperature, and in some cases the danger of dust explosion.

Referring to materials of Group C, these may be dried by passing through a single-shell drier encased in brickwork and allowing the heat to come in contact with the shell only, but this is an uneconomical machine to operate, due to the high temperature of the

* 170 Sumner Street, Boston, Mass.

escaping gases. The double-shell drier for this group, has at the feed end and about one foot from the delivery end riveted steel heads. Near the outer circumference of the shell are a number of tubes expanded into these heads. As the hot gases from the furnace are drawn through the central cylinder of the drier they are deflected by a flanged head at the rear and pass back through the tubes and out through the exhaust fan. The material to be dried is fed into the space between the inner cylinder and the tubes, falling alternately on to the hot inner cylinder and the cooler tubes until it is delivered dried through openings in the outer shell which is surrounded by a hood. The drier chamber is connected to the fan flue by a small flue with a damper, so that any desired amount of air may be drawn through the drying material to carry off the moisture. In this way the products of combustion do not come in contact with the drying material, while the advantage of a high temperature is attained. The efficiency of this class of driers is about 50 per cent. of the thermal value of the fuel used.

In regard to the materials of Group D, a drier using exhaust or live steam is the only practical one. This is generally a revolving shell in which are arranged steam pipes. Instead of a furnace and inner flue there is riveted into one end of the machine a steam head, expanded into which are steam pipes running to the other end with caps screwed on. The drier is set on a slight incline so that the water of condensation drains into the steam head as rapidly as formed. Material is fed into the drier by means of a screw conveyer where it is lifted and dropped by means of lifting flights back of the steam pipes until it is delivered dried through openings in the shell in front of the steam head. These openings are surrounded by a hood which delivers the material out at the bottom. A stack is used to create sufficient draft through the drier to carry off the moisture. The efficiency of this drier is about 85 per cent. of the calorific value of the steam used.

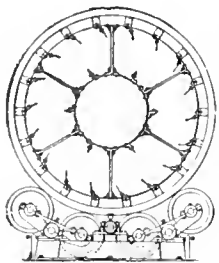

FIG. 3. END SECTION ROTARY DRIER, SHOWING CONCENTRIC SHELLS

For substances of Group E a rotary drier cannot be profitably used on account of frequent stops for cleaning. The only practical machine for such materials is one with a semicircular cast-iron trough having a shaft through the center carrying paddles that constantly stir up the material while at the same time they feed it through the drier. The semicircular cast-iron trough has straight sides and a cover; in the center of the trough is a shaft supported every few feet with bearings and equipped with cast-iron or cast-steel paddles as may be required. As the material is scraped from the bottom of the trough it is thrown to the top and at the same time fed slowly from the front end of the machine to the rear, where it is delivered dried, outside the side or rear wall either by a chute or screw conveyer. The drier shell rests upon side walls of brick and the products of combustion are drawn under the shell the full length, and return through the agitated material to the feed end and out through an exhaust fan. Should the material not be injured by a high temperature, but such as would be injured by the gases, the fan is placed at the opposite end of the drier and the gases are not returned through the material. If the material must be dried at a low temperature the furnace is omitted and steam jackets placed in the bottom of the cast-iron sections. The efficiency of these driers ranges from 45 to 60 per cent.

It may be further remarked that to dry certain inorganic material, not mentioned heretofore, where the capacity desired or the amount of moisture to evaporate is small or where the cost of additional fuel is not of great importance, a direct-heat single drier should be used. The most efficient type of drier for this case is one in which the heated gases meet the cold and wet material last and can be exhausted at a much lower temperature than when the gases flow in the same direction as the drying material. Machines of this kind have an efficiency of 50 per cent. of the calorific value of the fuel used.

Engineers have arrived at the point where they demand the correct drier for a given material and do not jump at their decision. All the chances for possible losses in efficiency are carefully weighed and capacity and durability are seriously considered. Reports indicate that for most purposes the double-shell drier is the most satisfactory and efficient while its serviceability has been the subject of much comment. Direct-contact single-shell driers should only be employed where the double-shell type is impracticable.

來 來

Portland Mine and Mills

Unwatering the Mine—Relative Cost of Chlorination and Cyanide Processes

The Portland mine, at Cripple Creek, Colo., one of the oldest gold mines in the district, since April, 1894, has produced \$32,827,058 in gold, and paid up to January 1, 1912, \$8,917,080 in dividends. This mine was hampered for a time by water, and although the Roosevelt Tunnel probably decreased the quantity to be pumped, nevertheless, it was not until the original tunnel was extended and after bore holes were put down that the Portland mine became comparatively dry, in the latter part of November, 1911. At this time the water discharge from the Roosevelt Tunnel had increased from 5,800 gallons to 12,000 gallons per minute. The latest advices state that the present flow from the tunnel is 10,000 gallons per minute and that it will be extended so as to unwater other mines. Owing to the decrease in water, ore breaking in the Portland mine materially increased, which naturally furnished more material for the company's two mills to treat. The old Portland mill, shown in Fig. 1, is a chlorination mill, which at present is being changed at a cost of \$100,000, to a modern cyanide mill.

Owing to Cripple Creek ore containing gold incased in tellurium, it was necessary to roast the ore previous to lixiviating; and because the chlorination process extracted a higher percentage of gold from ore and was not much more expensive to operate after roasting, it was adopted. Since the construction of the old Portland mill in Colorado City, great improvements have been made in cyaniding, and this, with the successful work at the new cyanide mill at Victor, shown in Fig. 2, has probably been instrumental in making the changes now going on in the old mill. A chlorination mill, properly worked, will recover 95+ per cent. of the gold, while, according to President F. G. Peck, the new mill recovers but 80.5 per cent. of the gold at a cost of \$1.13 per ton. In January, 1912, the old mill treated 8,800 tons of ore, having an average value of \$23 per ton and a gross value of \$202,400. By comparison of the percentage of recovery of the new mill with what should be recovered at the old mill, there is a margin of \$4.47 for practicing the chlorination process and coming out even; but if only 80.5 per cent. of \$23 ore is recovered, there will be \$3.45 in gold going to the dump, which, however, can partly be recovered at a cost of \$1.13, thus furnishing \$6.10 as the margin allowed for working the chlorination process. There are conditions, however, which have been worked out in favor of cyaniding, otherwise in all probability it would not be adopted. In December, 1911, the new Portland mill treated 12,285 tons of ore having an average value of \$2.80, a gross value of \$35,432.15, and a net value of \$28,533.75. The cost of treatment was \$1.13, and the percentage of recovery 80.5. In January, 1912, the mill treated 13,000 tons of \$2.97 ore, which should slightly decrease the cost of treatment.

The new Portland mill at Victor was designed for the treatment of low-grade ore coming from the mines and from dump material. During the past year this mill treated on the average 10,000 tons of ore per month, the average value of which was approximately \$3 per ton. The preliminary roasting once practiced to volatilize the tellurium and which cost from 40 to 60 cents per ton, has been discarded, and in its place a solution costing 10 cents per ton

substituted. The ore is sent from the mine and dumps in 5-ton electric cars which discharge into a steel tank bin from which it is carried by a pan conveyer to a 15"×32" Blake crusher. After crushing it is raised by bucket elevators to steel bins and fed to three sets of 24"×48" rolls running in series, from which it is delivered to four revolving screens equipped with $\frac{3}{8}$ -inch apertures. The undersize from these screens goes to a belt which conveys it to the main mill. The oversize is returned to the rolls. The $\frac{3}{8}$ -inch and

precipitation process. The precipitation plant consists of three 52-inch Merrill presses, each of which is capable of handling 500 tons of solution per day, although only the gold from 1,000 tons of solution is precipitated at present. The solution after precipitation is said not to assay over 1 cent per ton in gold. The filter product goes to the refinery, and the filtrate is sent by the triplex power pump to the mill-solution storage tanks.

The plant is complete as far as automatic handling of the ore is concerned, and is economical in the use of water, as only about 1,000,000 gallons of water is used in a month's run. The tailing from the plant is stacked on the dump in a fairly dry condition.

采 采

Ore Mining Notes

Idaho Metal Output for 1911.—Robert W. Bell, State Mine Inspector of Idaho, estimates the total output of Idaho metals for the year 1911 will closely approximate the following figures: Gold, 60,000 ounces; lead, 270,000,000 pounds; silver 8,400,000 ounces; zinc, 8,760,000 pounds; copper, 3,300,000 pounds, of a total value of \$18,420,000.

Cold Weather Stops Mines.—The Alba-Neck district mines near Joplin, Mo., with one exception, get their water supply through pipe lines connected with Spring River. During severe cold weather the river and system refused to flow, consequently mines and mills were shut

down. The one exception obtained its water from a deep-well pump and had no difficulty in continuing operations during the coldest weather.

British Columbia Platinum.—Returns have been received on assays of ore from the Tulameen platinum mines on Slate Creek, in the Similkameen district of British Columbia. The property is owned by the British Columbia Platinum Co. Assays were made

under product on its arrival at the main building is mechanically sampled by a Vezin sampler, which cuts out one one-hundredth of the ore. The reject from the sampling operation is elevated to the distributing conveyer, and with the ore not cut out is delivered to one of the four 200-ton steel storage bins, each equipped with a plunger feeder. Four 6-foot Chilian mills are used for crushing to a 20-mesh screen, cyanide solution being used for the operation. These mills have a capacity of about 90 tons each when crushing through a 20-mesh screen and consume about 60 horsepower in doing the work.

The 20-mesh product from the Chilian mills runs by gravity to three distributors, which divide the pulp equally between 24 concentrating tables. The tailings from these tables run by gravity to three classifiers where two products are made—sand and slime. The sand is mixed with barren solution and run to the washing plant, where it is washed free from soluble gold and then discharged on the dump. Classifiers are used as washers in this plant. As the slime flows from the three classifiers it is pumped back to 12 6-foot thickening cones. The underflow from these cones passes over nine Card concentrating tables. The concentrates from these tables join the concentrates from the first-mentioned tables and flow to bins in the lower part of the mill where they are loaded on cars and shipped to the old Portland mill, at Colorado Springs, for treatment. The slime from the Card tables flows by gravity to three Rothwell thickener tanks, where a clear overflow of gold solution is made for precipitation and a thick underflow of pulp is drawn off and goes to the agitators for further treatment. After 12 hours treatment in the agitators, the slime pulp is distributed to five Portland, revolving, continuous slime filters, from which the gold solution is drawn off by vacuum pumps, leaving the slime cake on the filter. The gold solution is next delivered to clarifying tanks, after which the gold is precipitated by the Merrill zinc-dust pre-

down. The one exception obtained its water from a deep-well pump and had no difficulty in continuing operations during the coldest weather.

British Columbia Platinum.—Returns have been received on assays of ore from the Tulameen platinum mines on Slate Creek, in the Similkameen district of British Columbia. The property is owned by the British Columbia Platinum Co. Assays were made



FIG. 2. PORTLAND MILL, VICTOR, COLORADO

from a ton of concentrate secured from a 15 to 1 reduction of ore. The yield was: platinum, 521.57 ounces; osmiridium, 58.82 ounces; gold, 75.82 ounces, and a small quantity of silver.—A. W.

Beaver Cobalt Mine.—The main shaft of the Beaver mine in Cobalt, Ontario, silver district is 550 feet deep and sinking is being continued. A level and shaft station is to be cut at 530 feet. The new mill should be running at the time this goes to press. The kind of ore being taken from the lower levels of the Beaver can be judged by the car which was shipped from the mine recently. The car con-

tained 30 tons of ore and a conservative estimate of the value of the silver in it was \$50,000. The ore was taken from the 300-, 350-, and 400-foot levels, the car in no sense being a picked one but contained just the run of the high grade from these levels.—C. N.

Interstate Silver-Lead Mining Co.—Consulting engineer of the Interstate Silver-Lead Mining Co., near Wallace, Idaho, reports an important strike on the property, saying that drifting on the ore is accompanied with excellent results. There is 7 feet of ore in the face of the drift and will soon be in solid galena, such as is mined on the Callahan and Hercules properties adjoining. The vein now being drifted upon was intersected by the lower tunnel at 3,000 feet.—A. W.

Germania Tungsten Mine.—Plans are on foot for the reopening of the Germania mine, a tungsten property in Stevens County, Wash. Wilhelm Scheck, president of the company, who has just returned from a trip to Germany, reports that he has secured sufficient finances to pay off the indebtedness of the company. He expects to put the mine on a producing basis in a short time. He will remain in Spokane until the plans for the reorganization of the company are completed.—A. W.

North Pole Mine, Oregon.—Another of the old producers, in eastern Oregon, which was abandoned a few years ago as "worked out," has come back. At the North Pole mine, near Baker, which was recently reopened, a vein of ore running in value close to \$100 a ton has been discovered in cross-cutting and it is announced that three to four cars of ore a week will be sent to the smelter. The ore will be shipped to Baker and reduced to concentrates and then sacked and reshipped to Tacoma.

Cobalt Output To Date.—The annual report of the T. & N. O. commission, prepared by A. A. Cole, mining engineer, was sent out from Mr. Cole's offices to the Toronto offices of the commission on Saturday night. Mr. Cole estimates the production of the camp at 32,000,000 ounces with a value of \$16,500,000. The report contains tables of shipments, reports, dividends, flow sheets of mills, etc., of the Cobalt camp, in addition to some excellent information on Porcupine and other camps in the district tapped by the T. & N. O. Railway.

New Ore-Testing Plant.—Twelve thousand five hundred dollars was recently turned over to the authorities of the Colorado School of Mines for the equipment of the new ore-testing plant. The building for the plant was built a year ago, and \$50,000 was allowed by the legislature for the necessary machinery, and one-fourth of this is what is now available. Many donations of machinery have been made by the various manufacturers, and it will now be possible to completely equip, ready for operation, the concentration section of the plant.

Ore Deposit.—The fundamental requirement for the successful working of an ore deposit is that there should be a sufficient amount of ore recoverable to pay for the direct and indirect cost of its removal and yet still leave a margin for profit. The cost of mining the ore is governed by a number of principles which vary greatly according to the local conditions.—*Mining and Scientific Press*. Correct.—*Mexican Mining Journal*.

The term ore deposit implies that there is some mineral in sufficient quantity to be worked at a profit. That being so, is not the plethora of words equally incorrect with the paucity?

Sitka Gold Deposits.—"The Sitka Mining District of Alaska," by Adolph Knopf, is a brief report just issued by the United States Geological Survey as Bulletin 504. While the output of the mines of the Sitka district has helped to swell the value of the annual mineral production of Alaska, the production has at no time been comparable with that of the big producing districts of the territory. The gold deposits of the Sitka district are found in quartz and the development has been that of lode gold mining. Although the first lode mining in Alaska is credited to the Sitka mining district in 1871—little or nothing was actually produced until 1905, when discoveries of auriferous lodes were made near Klag Bay, on Chitbagof Island.

Manufacture of Pig Iron in Washington.—International Lead and Iron Co. will erect two blast furnaces for the manufacture of

pig iron and cast-iron pipe within 10 miles of Spokane this year, according to H. H. Shallenberger. The company owns 800 acres of iron-bearing ground, embracing what is declared to be the largest body of hematite ore in the West. The ore will be mined with steam shovels. The property is located 15 miles south of Salmon, B. C., north of the boundary and nine miles from a railroad, but the extension of the Idaho & Washington Northern from Trail to the boundary line will afford a through rail route to Spokane. The mining company's properties and reduction plant will amount to more than \$2,000,000. Mr. Shallenberger announces that work on the furnaces will begin within 60 days.—A. W.

Pumping Shafts Through Drill Holes.—At the Geronimo mine at Ellissville, Mo., a shaft is being sunk that furnishes much water. To overcome the water difficulty, a sinking pump has been used in the shaft which evidently has not been of sufficient size to cope with the inflow. Previously to locating the shaft a prospect hole was drilled in the ore body near where the shaft is being sunk, and after the water became troublesome some one suggested putting a deep well pump in this hole. The result has proved more satisfactory than was anticipated and suggests the possibility of drilling holes nearby shafts for the purpose of keeping them unwatered during sinking operations, thus obviating the difficulties, expenses, and time consumed in connection with sinking pumps. At the Geronimo mine the rate of progress was about 5 feet a week; now it is stated that since the well pump was installed sinking goes on at the rate of 5 feet per day.

Mining in Georgia.—The Royal Mining and Milling Co. has been recently organized to operate the old Royal mine near Tallapoosa, Ga. At present, operations are limited to the treatment of tailing from the large amalgamation mill on the property. This mill formerly treated many thousands of tons of \$8 to \$15 ore at a very low efficiency of extraction. The gold exists in the ore in a form that is refractory to simple crushing and amalgamation, but cyanidation has been found to be eminently successful in extracting the metal. The mill has accordingly been sufficiently remodeled to install this practice. Samples of the dumps below the mill show the crushed ore to average about \$6 per ton, while one particular bed of the tailing is said to average nearly \$20 per ton. During the retreatment of this ore, it is proposed to unwater and reopen the mine so that extensive mining and milling operations may continue indefinitely. The ore body is an immense vein standing upright. The officers of this new company are H. H. Hawkins, president; Charles Sumner, manager; and J. W. Hawkins, secretary-treasurer.

"An Investigation of the Strength of Rolled Zinc," by Herbert F. Moore has been issued as Bulletin No. 52 of the Engineering Experiment Station of the University of Illinois. For many years engineers have been studying the strength of iron and steel, and though much remains to be learned about these, the commonest of metals, yet we have sufficient knowledge of their strength and stiffness to enable them to be used safely and economically. Very little attention has been given to the study of the strength of zinc, though that metal has had a wide use on account of its rust-resisting and electric properties. Zinc has, in fact, rarely been used in places where heavy loads were liable to be imposed. Recently, it was proposed to use loops of sheet zinc to suspend electric cables, and it became important to determine the strength of zinc so that such hangers could be designed to carry heavy cables with safety. The Engineering Experiment Station of the University of Illinois, at the suggestion of an Illinois zinc works, undertook the investigation of the strength of zinc, and the results of the investigation have just been published in this bulletin. The tests performed showed that thin sheet zinc is about one-third as strong as soft steel plate of the same thickness, and that a punch or shear which would punch or shear steel plate one-tenth of an inch thick would punch or shear zinc plate about one-quarter of an inch thick. Zinc plate was found to break under pull with much less stretching than steel, but a cylinder of zinc could be flattened out without cracking. Copies of Bulletin No. 52 may be obtained gratis upon application to W. F. M. Goss, Urbana, Ill.

An Oil-Fired Converter

Arrangement of Converter in Which Both Soft and Special High Class Steels Can Be Made

By Frank C. Perkins

The oil-fired converter shown in Fig. 1, was designed for the manufacture of various kinds of steel, from soft-steel castings to special steels of the highest class. It is now in daily and successful use at the works of the Darlington Forge Co., Ltd., Darlington, England. The converter is lined inside with ordinary silica brick and is used not only for the conversion of iron to steel, but also for melting the actual charge of iron and scrap by means of oil fuel.

The vessel is made oval in section, which affords an opportunity for exposing a large surface of metal to the action of the oil burners. For convenience, the vessel, besides being mounted on roller-bearing trunnions on the usual lines, is also mounted on a turntable, which can be revolved in the horizontal plane.

It is held that 3 tons of pig iron and scrap can be charged by three men in something less than 10 minutes. When charged, the converter is moved through an angle of 90 degrees into the necessary position for melting. Cold air is then delivered from the blower into pipes that pass through a heater and discharge through a central pipe coupled to the converter. The air blast has a pressure of about $\frac{3}{4}$ pound per square inch and a temperature of about 800 degrees, so that when this hot air is used for burning the oil very perfect combustion is obtained with a resulting economy in fuel.

The hot gases from the oil are naturally discharged from the nose of the converter, and are drawn through the preheater by means of a chimney. With a 3-ton converter the metal is melted in about $1\frac{1}{2}$ hours and is then at a sufficiently high temperature and in proper condition for blowing, which process only takes from 15 to 25 minutes, so that a blow can be made about every 2 hours. In blowing, the vessel is tipped upwards, the necessary hood and chimney for conveying away the fumes to the preheater being fixed directly above the nose. It will, however, be understood that if for any reason it is more convenient to arrange this hood and chimney in any other position, the converter can readily be turned round to such a position.

When the converter is in the position for pouring its contents into the ladle, it is turned through the necessary arc in the horizontal plane from the position in which the blow actually took place. The blast for melting and blowing is supplied from the same blower, but in the melting operation the air pressure varies from 3 to $4\frac{1}{2}$ pounds per square inch. The oil used for melting is the crudest petroleum available, and is stored in large iron tanks or in old boilers. From the storage tank the oil is forced, either by the blower or an air compressor into a smaller or service tank which contains a sufficient quantity for from five to six meltings. This service tank is fitted with a pipe coil through which hot air or steam

circulates to raise the temperature of the oil and decrease its viscosity.

The service tank is connected to a small independently driven compressor, which will maintain a constant pressure of from 30 to 35 pounds per square inch and force the necessary quantity of oil through a flexible pipe to the steel oil tubes in the tuyere box. The internal diameter of the steel tubes is about $\frac{1}{8}$ -inch and they are pointed through the center of the tuyeres.

When the melting operation is completed, the oil pipes are withdrawn, the tuyere box being arranged so that this can be done quickly. It is claimed that this system of making steel has the advantage that no cupola is required for melting, as this is effected in the converter, and as liquid fuel is used exclusively for melting, all risk of picking up impurities from fuel and flux during the process is avoided, while the loss of iron resulting from cupola melting is saved.

The high temperature of the melted charge allows of the use of pig irons low in silicon, or the use of higher percentages of scrap, and the metal is in such a state of extreme fluidity that it is possible to make the most difficult and intricate castings. It is further claimed that the amount of space occupied is comparatively small, due to the fact that the converter can be turned in the horizontal plane so that the arrangements for charging, blowing, and pouring can be provided in any convenient positions while comparatively small amount of power is required.

It is stated that with the oil converter cast-steel wheels have been made with 4-foot 9-inch diameters and of the following analysis: Carbon, .17 per cent.; manganese, .40 per cent.; silicon, .17 per cent.; phosphorus, .05 per cent.; sulphur, .025 per cent. These were machined solid and the metal furnished a tensile strength of 9 tons per square inch, and a 1-inch square piece was bent 180 degrees without breaking; there was also an elongation 30 per cent. in 2 inches.

Ingots produced for high carbon steel wire with this oil converter have had the following composition: Carbon, .70 per cent.; manganese, .40 per cent.; silicon, .01 per cent.; phosphorus, .017 per

cent.; sulphur, .015 per cent.; and have been rolled to No. 5 gauge rod, then drawn to rope wire. This metal stood the work well, giving a tensile strength of 110 tons per square inch. The ingots produced in the oil converter for low-carbon steel for seamless solid-drawn tubes, and having the appended analysis, drew well and stood British Admiralty tests: Carbon, .08 per cent.; manganese, .18 per cent.; silicon, .011 per cent.; phosphorus, .011 per cent.; sulphur, .01 per cent. The tensile strength was 23.6 tons per square inch; elongation, 43 per cent. in 2 inches; bending test on 1-inch square piece of metal was 180 degrees, and remained unbroken.

Carbon tool steel produced from this oil converter forges well, has proved very successful for chipping and caulking chisels, pneumatic tools, etc., while the high-speed tool steel is of excellent quality for mild-steel forgings. Its analysis shows carbon, .627 per cent.; manganese, .198 per cent.; silicon, .059 per cent.; phosphorus, .002 per cent.; sulphur, .007 per cent.; tungsten, 5.035 per cent.; chromium, 2.012 per cent.

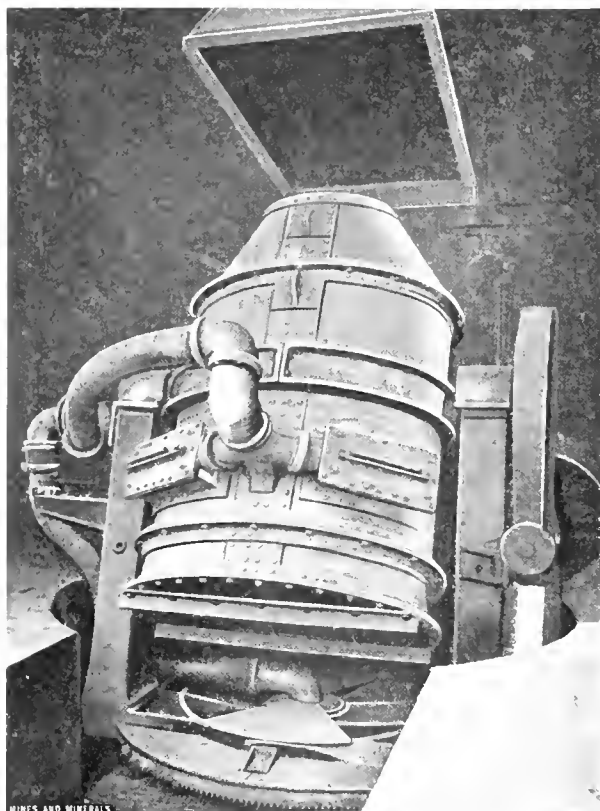

FIG. 1. OIL-FIRED CONVERTER

Unwatering Tresavean Mine, Cornwall

Electric Hoisting Apparatus—Methods of Handling Pumps in Shafts and of Sinking Suction Pipes

By Cyril Brackenbury

This article is abstracted from Bulletin No. 88, The Institution of Mining and Metallurgy, London, England. At this time when a number of old mines are being reclaimed it is believed that it will be as instructive as it is practical.

Tresavean is a famous old Cornish mine which is recorded as having first been worked some 150 years ago. During the first half of the nineteenth century Tresavean held a leading position in the county as a copper mine, and is also interesting as having had the first "man engine" in the county installed there. In the early fifties, when the lode was becoming poor in copper and expensive to work with the plant then in use, it had not yet been recognized that good copper lodes in Cornwall often turn to good tin lodes as depth is attained, so that though a good deal of tin was discovered in the lower workings no one thought much about it. Finally, in 1857, owing to a dispute between the landlord and mine owners and the reasons given above, the pumps were drawn up and the mine allowed to fill with water.

An attempt was made to unwater the mine by means of a Cornish pump between the years 1881 and 1887. A very great deal of money, about £100,000, was spent in the venture, and the company only succeeded in lowering the water a little further than the 166-fathom level below adit.

When the present company acquired the mine in 1907, none of the old pit work left by the last company was to be seen, and it was locally reported that the old column pipe had been blasted in more than one place below adit, so that it was thought the old work would be of little use as it stood. Moreover, it was considered that there would be a great advantage in having a larger space available in the shaft for winding purposes than would be possible if the old pit work were left there, or new Cornish pit work of a similar kind put down in its place. It was, therefore, decided to unwater the mine by means of temporary electrical pumps, to be replaced by permanent electrical pumps later, rather than by installing a Cornish pumping plant. Other important advantages considered were, that by putting in an electrical power-generating plant, the extra power available after completing the unwatering could be conveniently used for milling, winding, or any other purposes required about the mine, and one good central power plant could be run more economically and efficiently than several smaller independent plants scattered about the property. Again, it was thought that Harvey's shaft would be found in fairly good condition and practically free from chokes from a short distance below adit, in which case it was considered that the work could be carried out more expeditiously with electrical sinking pumps than by means of an ordinary heavy Cornish pumping plant.

Fig. 1 shows a vertical section of Harvey's shaft and Rogers' shaft, and the chokes, partial or complete, in the former are marked at their respective positions.

The unwatering has now been successfully carried out by means of electrical high-lift turbine pumps, in spite of serious obstacles, down to beneath the 218 fathom level below adit, which was the first object of the company, and as it is, I believe, the largest and most successful operation of the kind yet achieved in the county

with an electrical plant, some account of the work and difficulties overcome may perhaps be of interest. Up to the present date, eight electrically driven high-lift turbine pumps have been used in the work, but never more than three have been worked together, the others merely acting as spares.

Six of the pumps are designed for a delivery of 600 gallons per minute through a lift of 600 feet, when running at a normal speed of 1,450 revolutions per minute. An extra 60-foot head is allowed for suction lift and friction head.

Three of the pumps are used for sinking purposes and five are used as station pumps. The sinking pumps are of the vertical type and the station pumps horizontal. The impellers and diffusion vanes are all made of phosphor bronze, and with the exception of the last sinking pump, which has its casing made of gun metal, the other pump casings are made of special cast iron. The impeller shafts are made of nickel steel, and provided with water-cooled white-metal thrust bearings. Each pump has a throttle valve attached to regulate the discharge, and immediately above this there is fitted a check-valve to support the weight of water contained in the rising main when the flow of water ceases for any cause. Similar check-valves are placed in the rising main at distances apart of about 40 fathoms.

Each combined set consists of pump and motor, bolted to the same bedplate in the case of the horizontal pumps, and to the same channel-iron frame in the case of the sinking pumps. The motors are of the squirrel-cage induction type for sinking pumps, and slip-ring type for station pumps, all arranged for three-phase alternating current, 50 cycles, 550 volts. At full load, with a maximum current of 210 amperes, the motors are designed to give an output of 190 boiler horsepower. The motors for the vertical pumps are of the enclosed type, water cooled, and ventilated internally by means of a revolving fan attached to the motor shaft. The fan causes the air to circulate internally through the body of the motor, continually passing it next to the water-cooled sides. Fig. 2 shows No. 1 sinking pump at surface.

The power plant consists of three high-pressure Lancashire boilers and three Bellis & Morcom, compound, two-crank, high-speed engines, the last set having been only quite recently installed as a spare.

Two varieties of cables are used for the pumps: the smaller and more flexible type is used for the sinking pumps and lowered intermittently down the shaft, and the larger and heavier type is securely fixed in the shaft and connected with the station pumps. As the sinking pump cables are only for temporary use, the conductors were allowed to be of smaller cross-section than usual for the maximum current which might be used. Each cable is 7.4 inches in circumference, three-core pattern, .15 square inch section, pure and vulcanized rubber insulated, double-wire armored, braided and compounded over all. Weight about 1,240 pounds per 100 yards. Each cable for station pumps is 10 inches in circumference, three-core pattern, .217 square inch section, bitumen insulated, double-wire armored, braided and compounded over all. Weight about 3,210 pounds per 100 yards.

Each of the sinking pump cables is wound on a light-built steel drum, 6 feet diameter, 6 feet 6 inches between flanges, which are 9½ inches deep. The inner end of the cable is connected at the end of the drum axle with a plug, the other end of the plug is connected with a short length of cable leading from an oil switch at the feeder panel. The further ends of both cables, together with the wire rope which supports them, pass over three 6-foot diameter pulleys at the shaft collar and thence down the shaft to a junction box

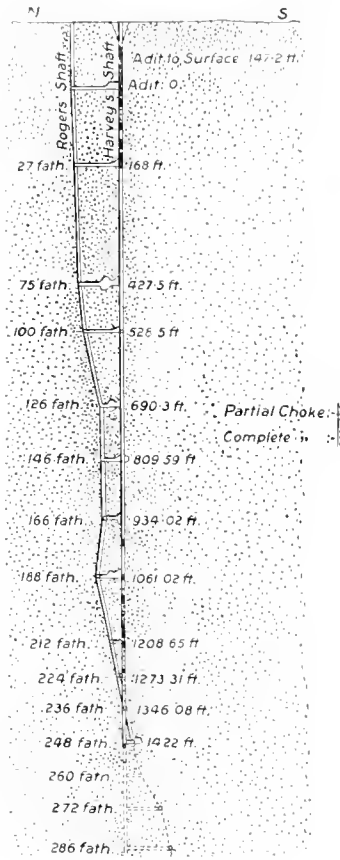

FIG. 1

suspended at the end of the wire rope. The suspending rope is made of plow steel, 3½ inch circumference, and is attached to both cables by means of wooden-lined iron clamps so as to support the entire weight of both cables. The clamps are fixed about 40 feet apart, and are designed to run on wooden guide rods fastened to the dividers of the shaft.

The two station-pump cables are securely fastened in the shaft by a series of wooden iron-bound cleats about 4 feet long and 10 inches wide, which are themselves bolted to the wall plates or other strong timbers in the shaft. These cleats are placed about 15 yards apart. The lower end of each cable is connected with an oil switch placed at the pump station, and the upper end is connected directly with the oil switch of the feeder panel.

The winding machinery for pumps, cables, and men, is driven by two electric motors, and also by a small steam winch which is used as a convenience in lowering the pumps slowly, and it could be employed in case of emergency if the electric power should fail.

The skip and man-cage hoist has a single drum 6 feet in diameter and 3 feet 3 inches wide, between flanges 9 inches deep. It can raise 3 tons 300 feet per minute. Post type of brake, drum speed 16 revolutions per minute, connected with motor by gearing and rawhide pinion; electric motor, synchronous, speed 500 revolutions per minute, 90 boiler horsepower slip-ring induction type. Speed is regulated by standard reversing controller with crane-rated resistances.

For raising and lowering the pumps and cables there is a combination three-drum hoist driven by a 30 boiler horsepower electric motor; drum A, 6 feet diameter, 4 feet wide between flanges, 12½ inches deep; drum B, 6 feet diameter, 3 feet between flanges, 10 inches deep; drum C, the same as B. All three drums are loose on their respective mild-steel shafts, and each one can be connected independently with the gear-wheels which are keyed to the shafts. The hoist is geared to give two speeds, 20 feet and 5 feet per minute with each drum, the fast speed makes one revolution of the drum per minute, and at this speed the hoist is capable of raising a maximum weight of 13 tons 11 hundredweight. The

gearing is driven by a 30 boiler horsepower motor of the slip-ring induction type, 750 revolutions per minute synchronous speed. The speed is regulated by a standard reversing controller.

The main hoist rope is ordinary lay, special plow steel, 2½-inch circumference; of the two pump ropes, the larger is 5.2-inch circumference, 340 fathoms and the shorter 4.8-inch circumference, 240 fathoms long. Both the ropes are of the ordinary lay, patent plow steel. The rope for supporting the electric cables is 3½-inch circumference, ordinary lay, special improved plow steel. The man hoist and pump hoist ropes were designed to favor a factor of safety of eight above the maximum dead load, and the cable support rope a factor of safety of six above the maximum dead load.

When the writer first came to the mine he found at Harvey's shaft an inverted cone-shaped excavation 40 feet in diameter at the surface, tapering down to the dimensions of the shaft, where the first solid choke began at about 46 feet below the surface. The necessary timbers were put across this hole, a windlass set up and the work of clearing begun without delay. Good solid rock was found about 40 feet below surface, and the first set of shaft bearers was put in at 46 feet from the top. It was soon discovered that the shaft was evidently about 12 ft. × 6 ft. within the old timbers,

and it was decided to make the new shaft in three compartments, two of them 6 ft. × 4 ft. within timbers, and the third compartment at the west end 6 ft. × 3 ft., the center dividers being each 6 inches wide. The top frame sets were all made of 8" × 8" pitch-pine timbers with the beveled miter joint; dividers 6 in. × 8 in., with dovetailed ends, are mortised into the wall plates; the studdles are 6 in. × 8 in., and the corner posts 8 in. × 8 in.; outside lagging 2 inches thick. The shaft timbering was designed with the object of first suiting unwatering operations, and afterwards permanent working conditions. The two large compartments were first arranged to each take one of the sinking pumps with all the necessary cables, tackle, etc., as well as the temporary 6-inch rising main. The third compartment is at present divided into two parts, one 3 ft. × 3 ft. 2 in. for the skip or main cage, the other only 3 ft. × 2 ft. 6 in. for ladder way. After the unwatering is finished and the proper hoisting arrangement has been installed in the two large 6' × 4' compartments, then the small skipway will no longer be required, and the whole west compartment, 6 ft. × 3 ft., can be used for the ladder way and permanent rising main.

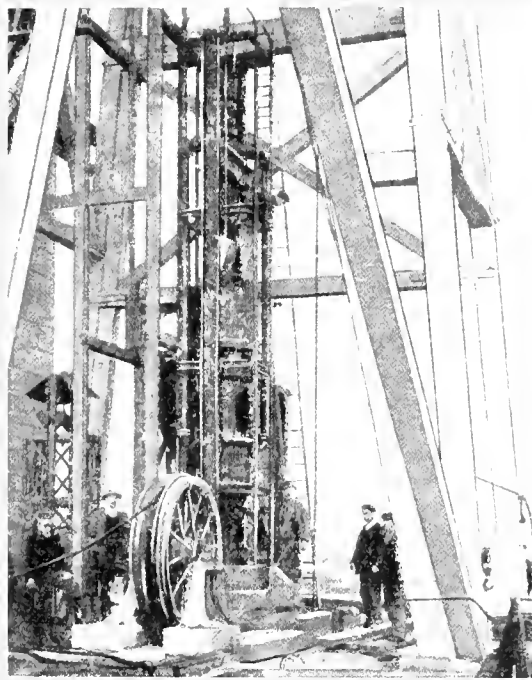

FIG. 2. SINKING PUMP, HARVEY'S SHAFT

Fig. 3 is a plan of the shaft, 17 feet below surface, showing positions of skip, pump, and junction-box guide rods. The regular timber sets with 2-inch lagging are only carried up to about 17 feet below the timber collar at surface, the intervening space being entirely secured by a 2-foot concrete lining, in which 6" × 8" dividers and end pieces alone are set to carry the necessary guide rods. The concrete lining is built from solid rock to surface, and the depths to which it goes down on the four different walls are as follows: South side, 36 feet; north side, 30 feet; east end, 29½ feet; west end, 46 feet. The proportion of cement used to the aggregate concrete mixture was about 1 to 7. Although the actual dimensions of the concrete wall were purposely varied a good deal according to conditions, the extremes being from 3 feet 6 inches down to 9 inches, it can be roughly stated as averaging about 20 inches thick with inside dimensions 13 ft. 8 in. × 7 ft. 8 in. In many places large loose rocks were built into the concrete wall, making it wider than 2 feet, and giving it more strength;

but on the other hand, where the shaft was also completely timbered and the surrounding country fairly well settled, the concrete lining was allowed to be considerably less than 18 inches thick. The opening between the concrete wall and the old sides of the cone-shaped hollow was carefully filled and rammed, and the head-gear foundation was built up of reinforced concrete resting on rough masonry covering a large base.

The head-gear was designed with a view to making it amply strong and suitable for the double purpose for which it might be required, that is to say, first for unwatering operations, and afterwards for regular mining work. The chief conditions which it had to suit were as follows: (1) To carry two sinking pumps with weight of attached suspending ropes, making total load of 12 tons and 14 tons, respectively; maximum speed of winding, 20 feet per minute. (2) To carry a 4-ton load in temporary skipway at a maximum speed of 300 feet per minute. (3) To carry 5-ton loads for regular winding in large compartments at a speed of 1,500 feet per minute. (4) To allow as high an opening as possible in one direction through the head-gear, so that the sinking pumps with their long, hanging frames could be easily handled. The pump pulleys were arranged to be fixed 42 feet above shaft collars, the

temporary skipway pulley at 59½ feet, and the regular winding pulleys at 60 feet above shaft collar. The opening left for the sinking pumps was 36 feet high. The head-gear fulfils all the required conditions. It is very rigid and has been cheaply built, the largest timbers used being only 12 in. × 12 in., with the exception of the two old pieces, 15 in. × 15 in., which remained over after having been used as original supports across the 40-foot excavation.

A temporary rock bin and chute has been built on the head-gear to take all material discharged from the temporary skip during unwatering operations, and a small tram line leads northerly from the rock chute out over the dumps in one direction, and another small line leads southerly from the skipway, its object being to facilitate the handling of all heavy and bulky material such as the old pit work, which is drawn up through the shaft by means of the rider frame alone, without the skip being attached. The tram rails extend over folding doors which open and close over the skipway, so that wagons can pass directly under the rider frame and skip when required, and the skip is removed from the rider frame, or both are removed together from the rope coupling by this means.

The skip and rider-frame arrangement was specially designed to fit the peculiar conditions and requirements of the case, and a detailed description may perhaps be of interest.

Fig. 4 shows elevations and plans of the sinking skip and the rider frame. The channel irons *J*, which form the chief portion of the rider frame, act as guides and run on 4"×2" guide rods fixed in the skipway. The rectangular iron frame *L* encases the skip or any other large and heavy body which is to be raised or

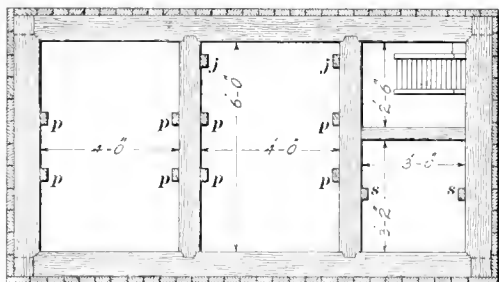

FIG. 3. PLAN OF SHAFT

lowered in the shaft. The top horizontal bars *I* are used to stiffen the frame and also as a safe step on which two men can stand to ride on the frame when it is traveling in the shaft. *C* is the top connection of the rider frame, which, when unbolted, allows the frame to be taken off the rope; it also encases the beechwood bushing *B*, in the form of a reel, through which the wire rope passes. *E* is a rubber pad which fits into the cast-iron casing *F*, and forms with it a buffer between the rope socket and the rider frame. The iron casing *F* is made a comfortable fit for the rope socket *G*.

The sinking skip has a capacity of 24 cubic feet and is made with a sloping bottom so that the contents may be easily discharged after merely knocking up the door catch. The special features about the skip are that it has no guides of its own, but is dependent upon the rider frame to carry it safely through the skipway, and, being rectangular in shape, it cannot revolve in the frame like an ordinary sinking bucket with crosshead. For the size of the shaft compartment it is able to be of much larger dimensions and capacity than an ordinary sinking bucket could be, and it is more easily discharged. The skip is made to pass easily in and out of the rider frame by the suitable shape of the bail *K* with the trunnion shields *P* and the sloping top ends *M* and *N*. The small rings *T* at the bottom of the skip were put there to pass a rope through in case it was required to help in guiding the skip into the frame when moving up from the bottom of the shaft, but it was never found necessary to use a rope for this purpose.

This particular form has the following advantages over an ordinary sinking bucket: (1) It has a larger capacity; (2) it is more easily discharged; (3) it will not revolve in the frame, and

is safer and better for men to ride on, and not so injurious to the rope. The rider frame has the following advantages over the ordinary crosshead bucket guide: (1) It is a safer guide in a confined space; (2) it has sufficient weight to travel down the shaft on the end of the rope by itself; (3) two men can quite safely ride on it alone; (4) it is particularly suitable for drawing up large material, such as pump rods, column pipes, etc., in a confined space. An ordinary skip would, of course, be most inconvenient, and unsuitable for working continually below the guide rods and repaired portion of the shaft, as is the case with unwatering operations, and with the very small space left for temporary winding purposes an ordinary bucket and crosshead guide would be very inefficient and inadequate.

It can be easily understood how safely and conveniently other large and heavy materials can be drawn up instead of the skip, providing it is possible to make one end enter the frame of the rider. The combination skip and rider frame carries eight men, divided as follows: Four inside skip, one standing on top of front end *N*, one on top of back end *M*, and two facing each other on cross-bar *I*. This number makes a fairly close fit, but is quite safe for traveling in the skipway compartment of the shaft.

The preliminary work at the mine consisted chiefly in clearing and repairing the adit level, opening up Harvey's shaft down to adit level, erecting head-gear, repairing old buildings, and putting up new ones, getting the reservoir into shape, and bringing in the new water supply, also any of the foundation work that could be decided upon before the final plans of the plant had been made. The adit was found in bad condition and it was cleaned out and repaired for a length of about 4,500 feet, before pumping started; since then it has been cleared and repaired an additional length of about 4,000 feet, and a total of about 8,500 feet. The 4-inch iron pipe carrying the chief boiler water supply comes through the fields and over the dumps for a distance of about 5,100 feet, and a number of small branch lines had to be laid from it to various water tanks which were put in for the benefit of farmers through whose land the main pipe-line passes. The second water supply, carried through 7-inch stoneware pipes, is laid in the same trench as the first for a distance of about 3,850 feet.

Harvey's shaft was cleared, secured, and equipped down to adit level and the head-gear erected long before the pumping plant was ready to start operations. The work of the first 80 feet or so below surface was carried out with an ordinary hand windlass and bucket, and from this depth to water level, 150 feet below surface, the work was carried out with the help of a small steam winch and tip bucket, the wire rope passing over the pulley of a small temporary head-gear which was erected on the platform over the shaft excavation. The adit level was opened at a depth of 147 feet below top of shaft collar, and the station was enlarged here to take two V-notch delivery tanks, each fitted with a patent water recorder.

Before pumping operations began the choke was cleared to a few feet below water level, and after the first day's pumping there were severe chokages which lasted, with only short clearances between, all the way down to the 27-fathom level, where the last of the chokage was found resting on doors at the level 168 feet below adit. The pumps were not designed to handle the broken rock, gravel, crushed timber, and grit found in all the chokes, and special means were needed to safeguard and spare the sinking pump. The best way out of the difficulties sometimes was by getting the suction down through holes in the chokes into clearer water below, and sometimes by putting the suction pipe down in the old pump column, which was still standing in place in the shaft. In the latter case it was occasionally necessary to blast out the sides of the old column to let in the water, after having first secured it firmly with chains and timber.

One blast was fired electrically at a depth of 57 feet below the top of the pipe, which projected 2 or 3 feet above water level. A special strainer had to be made to put down inside the column pipe, with special connections across the shaft to the pump; also, since the blast completely severed the old column pipe, it was necessary to secure and support the length of column above the blast with chains below each 9-foot length, as it was taken off before

lowering the pump. In one instance, when the old column pipe was itself choked with debris, the difficulty was overcome by driving down a 2-inch pipe through it to the bottom, a distance of 18 feet, and then blasting out the bottom, which fortunately also cleared the debris and left a clear passage for the suction.

When near the doors of the 27-fathom level a method was resorted to which has proved satisfactory for all deep solid chokes. The method consists in substituting for an ordinary suction pipe a special one with a sharp point at the lower end, to enable it to be driven down through the choke, and with a connection at the upper end to which a special valve box containing a strainer can be fitted. The conical point is made of mild steel, and can be welded on or screwed to the lower end of the suction pipe. The iron suction pipe should preferably be made in lengths, for each lowering of the pump, that is to say, in about the same lengths as each section added to the rising main. As the pump is lowered, and each length of suction pipe uncoupled, a screwed flange is taken off the last length which has just been removed, and screwed to the upper end of the next length remaining on the suction, in place of the coupling which was used to connect the two lengths together. The valve box is fitted with connections, so that the bottom may be bolted to the flange at top of the special suction, and the top bolted to the flange of short pipe connection to pump. Inside the box there is an ordinary clack valve at the bottom and a strainer fastened to the top, but bent into a synclinal fold so as to expose as large an area as possible to the inflowing water. The box is divided in the middle, and can be easily opened to examine and clean the strainer or valve. In the first instance this method was used to pump through a choke only a few feet thick resting on doors at the 27-fathom level, and the steel-pointed pipe was easily driven down through some 8 feet of debris and through the wooden doors which were supporting it. After having driven the end of the pipe a few feet below the platform, the point was blasted off, the upper end was connected to the valve box, and the valve box connected to the suction end of pump by a short length of pipe forming a reverse bend. The pump worked very satisfactorily with this arrangement, keeping the water well down below the top of the choke and enabling the men to conveniently clear it away.

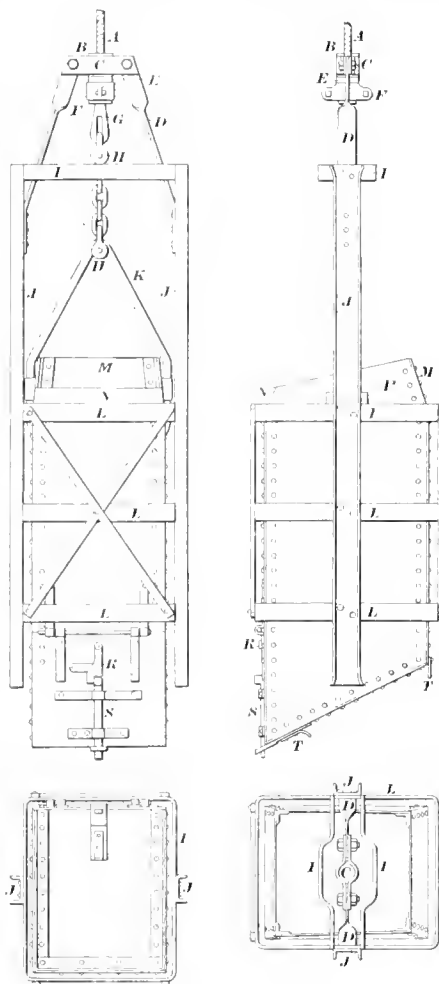

FIG. 1. SINKING SKIP

After 5 months work the sinking pump began to fail, and it became evident that it would have to be taken to surface for repairs. No. 2 sinking pump was made ready, moved into place, lowered down the shaft, connected up and set to work in 5 days, when the water level stood at about 273 feet; it did not, however, run steadily until the next night.

An old balance bob was found in place at 275.5 feet below adit with the front end projecting several feet over the north side of the shaft. The end of this was cut off. There was much heavy old pit work to be removed from here, including the usual plunger barrel, H piece, cistern and timber supports, and this work caused some delay in the rate of sinking, so that only 13.8 feet was made during the week. About this time the increase in inflowing water from 250 gallons per minute to 450 gallons per minute began to delay the work somewhat. On November 20 the water level was down to 527.2 feet, so that up to this date the average progress for the 208 days since starting pumping works out at a little more than 2.53 feet daily, including all stoppages from any cause whatever. On November 20 No. 2 motor short-circuited, due to leak-

age of a small cooling water pipe, which had been corroded through and had then been spraying water into the motor windings for some time without being noticed. No. 2 pump was taken to surface on the 22d and the motor removed, and No. 1 motor coupled to the pump in its place. The pump was then lowered again and set to work when the water level had risen up to about 440 feet. By December 13 the water stood just 1½ feet lower than the depth reached on November 20. At this depth the floor of the 100-fathom level was uncovered.

It had been originally intended to install the first station pump at the 100-fathom level, but as the incoming water increased to 660 gallons per minute the sinking pump was unable to hold it and was driven back up the shaft to 417 feet below adit. As soon as it was found that the sinking pump could not hold the water it was decided to alter, cut out, and fit up the 75-fathom station so as to install a duplicate set of horizontal pumps there, instead of at the 100-fathom level. Also as a large portion of the inflowing water could be caught at this level by putting in a line of launders about 700 feet in length, work was immediately started for this purpose. One of the large cables for station pumps was lowered down the shaft and fixed in position, and the second 6-inch rising main carried down to the 75 station. The old balance-bob hole was dammed up and made into a good reservoir to take the water from the 75-fathom level and also from the sinking pump below, both these water supplies being first passed through strainers and V-notch measuring boxes.

The first station pump was installed with all the necessary electrical and water-pipe fittings and set to work with one impeller removed, when the water level stood at 462 feet below adit. This pump had at first to be throttled down to take only the water from the 75-fathom level, which was then about 200 gallons per minute, but this sufficiently relieved the sinking pump, so that the water level was reduced down to 494 feet. Unfortunately, it was then found necessary to take No. 2 sinking pump to surface for repairs, leaving only the new station pump to pick up the water at the 75-fathom level. The newly repaired No. 1 sinking pump was lowered down and set to work. The station pump and the sinking pump then ran in parallel, each delivering its separate supply of water to adit, and lowered the water a distance of 137 feet in 24 days, in spite of the fact that the incoming water was 735 gallons per minute and had only decreased down to 580 gallons per minute. The two pumps together were delivering over 1,025 gallons per minute to adit. The station pump next received its supply of water from the sinking pump as well as from the 75-fathom level, and after the fifth impeller was replaced, it delivered as much as 715 gallons per minute to adit from the cistern at the 75 fathom station.

The average rate of sinking made during a second period of 10 weeks comes out at 35 feet per week, or 5 feet each day. For the third period of 4 weeks the average speed was 42.1 feet per week, or just over a fathom each day.

The average speed for the 390 days since the start of pumping comes out at about 2.37 feet each day, or say 16.2 feet each week, including all stoppages. At the beginning of June, No. 1 sinking pump was working near the limit of its hydrostatic head, and its delivery was consequently small, finally decreasing so much as only to equal the quantity of incoming water. It was stopped and taken to surface for repairs, and No. 2 sinking pump was lowered and at

work in 2 days. Between the 166-fathom and 188-fathom levels, however, three nearly solid chokes each from about 10 feet to 15 feet thick were met, and the rest of the way was partly choked, and with bad water walls to the shaft. Fortunately, weak spots were found, and by means of grab hooks holes were made through which the suction was put down and the water kept below the top of the choke.

To protect the strainer, it had to be constantly cleaned, sometimes with a long-handled brush used under water, but often it was necessary to raise it out of water to clean it properly. Working through chokes in this way causes severe wear to the pump, as a certain amount of grit will continually pass through the strainer and up the suction pipe into the pump chambers. The thrust bearings are also liable to become heated, on account of the small cooling water pipes getting choked and thus preventing free water circulation through the water jacket. The strainer used is made of copper sheeting with $\frac{1}{2}$ -inch punched holes, which, however, soon wear to a slightly larger diameter.

A cross-course first touches the shaft at the 166-fathom level, and from there down to the 236-fathom level the shaft has been badly broken up and disturbed by it. A good deal of work had to be done at the 166-fathom station in order to make a suitable room for two station pumps and a cistern to take the delivery from the sinking pump, as well as the small amount of water picked up at the level. The water supplies from the sinking pump and 166-fathom level are led through strainers and V-notch measuring boxes as is the case at the 75-fathom level station, and there is an arrangement of pipes by means of which the water delivered from either station pump can be circulated back through the cistern. This arrangement has been occasionally used for testing purposes. There is also a branch from the sinking-pump delivery taking the water back in the level, and this pipe, which is controlled by a throttle valve, can be used whenever it happens that, from some cause or other, the delivery from sinking pump exceeds the delivery from the station pump. There is only one rising main from the 166-fathom to the 75-fathom station, and each station pump is independently connected to it.

No. 2 sinking pump took the water down to 1,035 feet below adit while delivering up to the 75-fathom level, so that the shaft was cleared and repaired down to this depth at the same time as preparations were made at the 166-fathom level for the new station pumps. Unfortunately, neither of the new horizontal pumps for the 166-fathom station were delivered until long after the time promised, and the first one could only be started on regular work by September 17. The conditions then were: No. 2 sinking pump delivering to 166-fathom station; No. 3 station pump taking water from 166-fathom level and from the sinking pump, and delivering to the 75-fathom station; No. 1 or No. 2 station pump taking water from 75-fathom level and from No. 3 station pump, and delivering to the measuring tanks at adit level.

栗 栗

Cloth Pinions for Electric Motors

Cloth pinions are highly successful devices for reducing the noise and increasing the life of power transmission gearing. Metallic gearing, especially steel, is always more or less noisy in operation, the noise becoming particularly troublesome in the case of high-speed gear trains. Furthermore, iron or brass gearing has not sufficient ability to successfully withstand the shocks or back lash caused by the torque variations incident to the operation of machine tools.

In order to overcome these drawbacks various kinds of non-metallic materials such as rawhide and paper, have been used instead of iron and cast iron for one or more members of gear trains. The results have been only partly successful. As a rule pinions made of such substances were not sufficiently impervious to moisture or unaffected by exposure to heat, and in the case of rawhide were liable to injury by rats and mice when kept in stock.

In cloth pinions those defects are entirely eliminated, both by the nature of the material and the method of construction employed. The blanks from which the pinions are cut consist of a filler of cotton or similar material confined, at a pressure of several tons to the square inch, between steel "shrouds" or side plates, the whole structure being held together by means of rivets, or, in case of very small pinions, by threaded sleeves. After the teeth are cut the cloth filler is impregnated with oil. Cloth pinions are entirely impervious to moisture, unaffected by changes in atmospheric conditions, and absolutely vermin proof.

The teeth are cut to the $14\frac{1}{2}$ -degree involute system. Diametrical pitch is the standard of measurement, and companion gears should be cut to similar form. The teeth are stronger than those of any other type of non-metallic pinion, and are sufficiently elastic to allow the meshing teeth to bear evenly across the full width of face, thereby enabling the combination to absorb shocks capable of fracturing cast iron or brass. The pinions are self-lubricating, operate noiselessly, and have long life. Of several thousands of pinions in operation under severe conditions for periods ranging from a few months to two years, none have shown any appreciable signs of wear.

Cloth pinions have a wide range of application. They are particularly suitable for use on the shafts of back geared motors employed for driving lathes, planers, drill presses, shears, punches, and other machine tools.

栗 栗

Stratton's Independence Mill

As an addenda to Philip Henry Argall's article in the December, 1911, issue of MINES AND MINERALS, the following from the Colorado School of Mines Quarterly will prove interesting:

The mill at Victor, Colo., started operation April, 1908, at 4,500 tons monthly capacity. The present capacity is 10,000 tons per month. The ore is taken from the dump and delivered in the mill at a cost of 9 cents per ton, by an electrically operated power shovel. The value varies from \$2.50 to \$3.25 per ton.

The ore is first passed through a No. 7½ Gates breaker, then sorted on an endless picking table, then passed through a No. 5 Gates breaker and thence conveyed to a 300-ton storage bin. This breaker plant works one eight-hour shift per day with four men, one man operating and three sorting ore. The ore from the storage bin is, as required for Chilean mills, rolled to about $\frac{3}{8}$ inch to $\frac{1}{2}$ inch. This section works two shifts with one man on each shift. For fine crushing, there are three shifts per day, with one man per shift. For concentrating, there are three shifts per day, with one man per shift. For cyaniding, there are three shifts, with two men per shift. Three laborers are employed during the day shift loading concentrates and doing roustabout work. A machinist and helper and one carpenter are kept on repairs and general maintenance. In addition to the above list of 27 men there are two superintendents, one chemist, one assayer, one sampler, one electrician, making a total of 33 men per day, or an average of 11 men per shift. Divided, however, as follows: First shift, 22 men; second shift, 5 men; third shift, 6 men; total, 33 men.

Although the mill can be operated with five men on a shift, the average, including superintendent, chemist, assayer, and repair men, is 11 men per shift.

The process is a combination one, as follows:

- (a) Coarse crushing with breakers and rolls.
- (b) Fine crushing with Chilean mills in cyanide solution.
- (c) Sliming in tube mills.
- (d) Concentrating on 21 Card tables, 13 Deister slimers, and four vanners.
- (e) Cyaniding slimes and sands, the former with bromo-cyanogen.
- (f) Concentrates sold to smelters.

In April, 1911, the total milling cost per ton treated was \$1.2146. In May, 1911, it was \$1.2606. The recovery is from 65 to 75 per cent., depending on the value of the ore. The average is about 70 per cent. on \$3 ore.

The Tesorero Mine Aerial Tramway

A Tramway of the Bleichert Type Ten Miles Long for Handling Iron Ores in Spain

By Frank C. Perkins

The construction and method of operation of the mining aerial tramway of the Sociedad Anonima Minas Del Tesorero, near Madrid, Spain, may be noted in the accompanying illustrations. This ropeway, of the Bleichert type, has a length of about 10 miles, with a fall in the direction of the traffic of about 1,750 feet. It serves to convey iron ore from the Mernan, Corteo, Elektra, Manolito, and Paris pits, near Tesorero, in the Province Granada, to Hijate, on the Lorco Baza Railway.

As the ores from these various pits are of entirely different specific gravity and contain fluctuating quantities of moisture, the carrying capacity of the line naturally varies. For instance, when the heaviest kind of ore is being transported from the Paris pit the hourly capacity is 40 tons, whereas, when conveying the light-weight ore, only $31\frac{1}{2}$ tons are transported per hour. The velocity of the buckets on the line is $8\frac{1}{4}$ feet per second.

On account of ground difficulties, the introduction of an angle point, Fig. 1, in the ropeway was necessary. There are, therefore, two main lines, the loading station being 5 miles distant from the intermediate station and the unloading station 5 miles from that on the railway at Hijate. A most interesting feature in this Spanish aerial tramway is the automatic coupling and uncoupling of the carriages to the continuously moving traction rope by means of an automatic coupling device. In the vicinity of the ore pits is located the loading station of the Tesorero ropeway and the

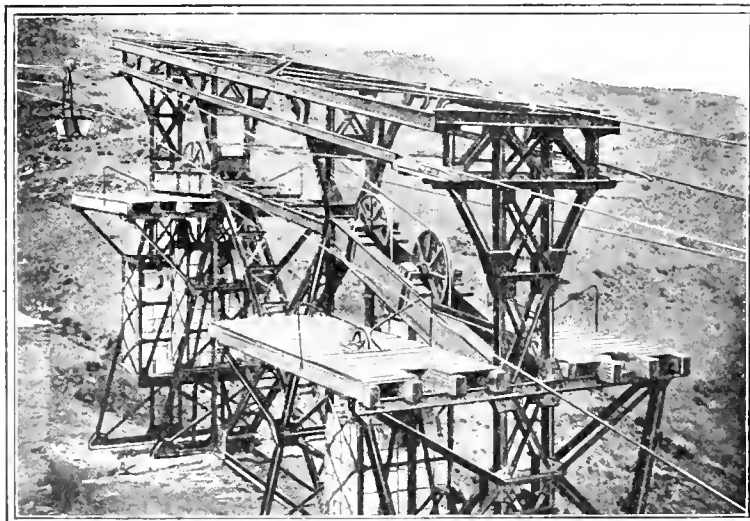

FIG. 1. TENSION DEVICES, TESORERO MINES

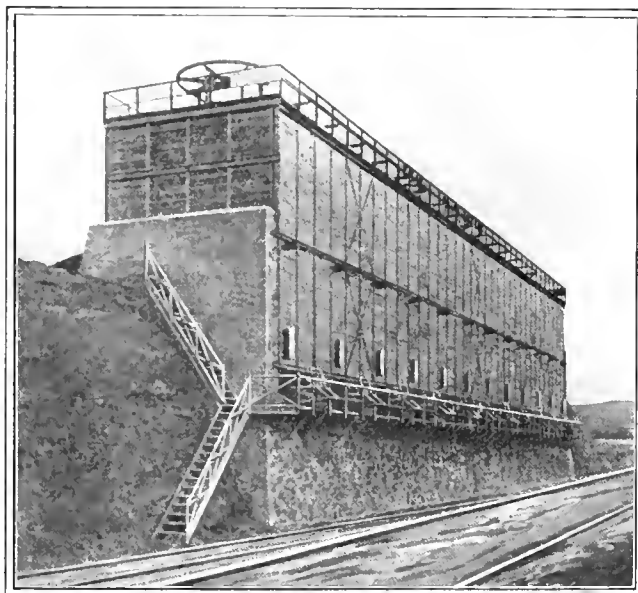

FIG. 2. UNLOADING STATION AND ORE BIN AT LA HIJATE

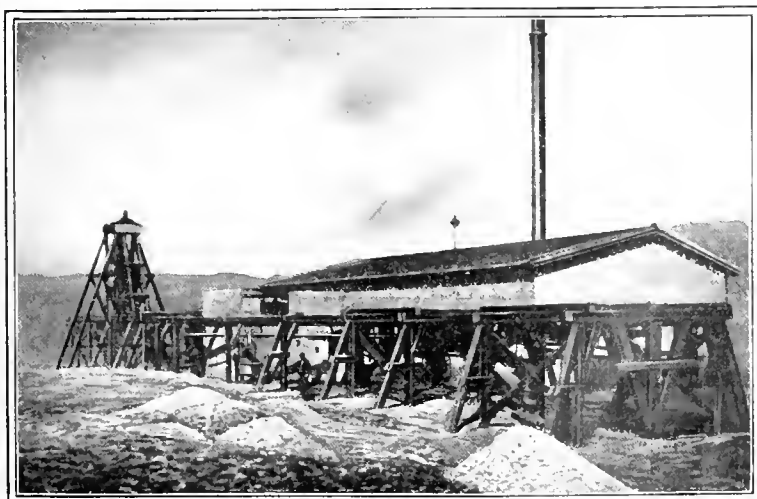

FIG. 3. POWER PLANT AT INTERMEDIATE STATION

ore is carried along narrow-gauge tracks over a hopper, where the pit cars are discharged, and from which point the loading of the buckets is effected by means of special escape gates.

The loading station in which both the carrying and traction ropes are stretched is of timber construction. The unloading station, Fig. 2, is also a storage bin, constructed on a side hill on a stone foundation. Its height is about 36 feet above the level of the railway tracks.

The ore is stored on the slanting floor, on the space enclosed by the foundations, giving the bin a capacity of 50,000 tons. The railway cars are loaded from the bins by means of 12 hinged chutes spaced at intervals along the 100-foot front. The buckets are run over a loop on the deck of the storage plant and as they are tipped by hand the ore can be placed in any bin of the storage plant, and thus keep the ores from the different mines separate or mix them, as it may be desired. The wire rope on which the loaded bucket carriages travel is 35 millimeters in diameter, but that size being unnecessarily expensive for empty buckets, the return carrying rope is 22 millimeters in diameter. These ropes are supported on 148 iron towers of varying heights with a space of $8\frac{1}{4}$ feet between the ropes. Where the spans between towers are so long as 2,000 and 2,300 feet, as at the $3\frac{1}{4}$ - and $5\frac{1}{4}$ -mile points on this line, the next towers are constructed double and four in number, with heights of from 55 to 95 feet; also on account of the great length of the line, several tension stations were found necessary to strengthen and decrease the sag in the carrying ropes.

Besides the tension appliances at the two end stations, a double-tension device, Fig. 1, together with special anchorages, have been provided on each of the

sections. These middle tension appliances are so constructed that the cars can pass through them automatically, without requiring any special attention or supervision.

The power plant and driving machinery for the line, shown in Fig. 3, is installed at the angle station, Fig. 1, level on the plateau of the El Corbull Mountain, and the cars are guided through this intermediate station by hand. The first section of the line requires an average of 17 horsepower to move the buckets, while the second section, from the angle station to the unloading station, furnishes an excess of 30 horsepower.

This power is developed by the moving buckets when the line is in regular operation down grade. The drive of the first section is effected by means of a power plant of moderate capacity, and for the second section it was necessary to install a hydraulic regulator in connection with the driving gearage, to act as a brake for the excess power, and regulate the speed of the buckets.

It is maintained that this Spanish aerial tramway, with its comparatively large capacity, has opened this mining district to industrial enterprise, providing better means of subsistence to the inhabitants of these mountain regions, and has proved not only a source of profit to the mining company, but also, in a large degree a boon to the whole neighborhood.

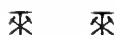

Some Kalgoorlie Hoisting Arrangements

In West Australia the laws governing safety appliances in and around metal mines are fully as complete as those in the best regulated coal mining districts of the United States. Even where ordinary bucket hoists are used instead of cages it is required that provision be made for guides. To H. N. Spicer, mining engineer, of Denver, but formerly of Kalgoorlie, we are indebted for the following description of some simple, cheap, but effective arrangements to this end, which might well be adopted in the United States:

In order to prevent the bucket from striking the sides of the shaft and to permit of more rapid hoisting, a bucket rider, as shown in the side view in Fig. 1, is made. This is built of two pieces of 4"×4" timber, *A* and *B*, separated by two other pieces *C* of 2 in.×4 in. The timber frame is first spiked together. Two pieces of 4"× $\frac{3}{8}$ " flat iron *D* are then bolted to this frame through both *A* and *B* and the two pieces *C*. Through *A* and *B*, holes are bored to permit the insertion of pieces of 1½-inch gas pipe through which the 1-inch hoisting rope passes. Where the rope passes between the iron cross-braces *D*, a piece of pipe as shown in Fig. 2, is inserted. This is made by taking a piece of, say, 2-inch pipe, 7 to 9 inches in length, and slitting it for about 1 inch at each end, Fig 3. The rope is then lined in and the two ends battered down upon the braces. This and the two bolts shown in the figure clamp the braces tightly together. At some mines flat pieces of iron are used to strengthen *A* and *B*, being bolted to them longitudinally for their entire length and in other cases straps are passed over *A* and *B* and bolted to the uprights *C* and *C*.

To prevent a sudden raising of the bucket, breaking the lower bar *B*, it is strengthened where the rope passes through by a 4"× $\frac{1}{2}$ " plate of iron about 8 inches long. On the rope socket is a similar but much heavier plate of iron *E*. This is not infrequently as much

as 1½ inches thick to prevent bending, or a casting may be used.

As the arrangement of the guides varies, so will some of the details of the bucket rider. A common and cheap form of guides is shown in Fig. 4. Here the guides are set in diagonal corners and are made of two pieces of 3"×8" and 3"×5" timber, although almost any size stuff may be used, such as 3 in.×6 in. combined with 3 in.×3 in., etc. These are spiked, bolted, or screwed, to the shaft timbers, all heads being countersunk. At abutting ends the ordinary scarf joint is employed. In placing the guides in position two pieces of the determined size are spiked together on the edges and lowered into the shaft. When lining up, it is generally found that the main shaft timbers are more or less out of alinement and they may have to be dapped in places, and on others pieces must be nailed to them, to insure perfect verticality on the part of the guides. With this arrangement of the guides the upper and lower pieces of the rider are beveled to fit into them with a clearance of about $\frac{1}{4}$ inch at each end. In some instances the ends of the rider are bound with a thin piece of flat iron to prevent wear.

With the ordinary end guides, Fig. 2, the arrangement of the bucket rider is different. In this case the ends of the braces *D* are extended beyond the timbers *A* and *B*, and are slightly curved outward. At the ends and on the side of *A* and *B* where there is no brace, a piece of iron 4 in.× $\frac{3}{8}$ in. is bolted and bent to the same shape as are the two ends of the braces. This forms a shoe or channel to engage the guides.

This arrangement is not employed with first-motion engines, but is used with very large geared engines hoisting from depths of 500 and more feet. The importance of this little device is obvious. Not only does it prevent the bucket from knocking against the sides of the shaft resulting in possible dislodgment of timbers and, when men are being raised, in loss of life, but it permits of the use of the full power and speed of the engine with no more liability to accident than when cages are used.

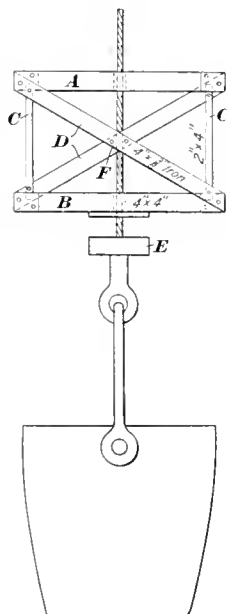

Fig. 1

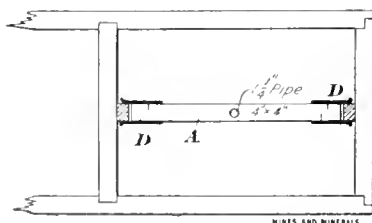

Fig. 2



Fig. 3

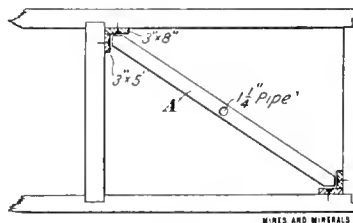

Fig. 4



Minerals in China

There are in Kwangsi, deposits of coal, antimony, and tin, worked by the natives on a small scale and by primitive methods. According to the United States Consular Report, much of the coal is of superior quality and some of it has found its way to the Canton market. The tin mined in Kwangsi is crudely smelted on the spot and sent down to Wuchow for export as tin slabs. A few years ago the high price which antimony reached on the Hong Kong market prompted the merchants of Wuchow to install an antimony smelter at that place, but as the price of antimony dropped soon after to normal figures, the smelter has since remained idle. Quicksilver mining has been attempted in Kweichow by an Anglo-French syndicate, but with no success. Coal is found throughout Kwangtung proper and in the Island of Hainan, but is worked only by native methods and on a small scale. It is of indifferent

quality and scarcely figures as an article of commercial importance. The tin mines of Kochiu, in Yunnan, are exceptions to the usual conditions found in China, as they are operated by advanced methods.

The Amherst, Quebec, Graphite Deposits

Geological Conditions—The Nature and Extent of the Deposits
—Theories As to Their Method of Formation

By Fritz Cirkel

The following is abstracted from an article by Fritz Cirkel, in the Journal of the Canadian Mining Institute.

Graphite commands a higher price than at any time in its history, and the present increased activity in developing Canadian graphite deposits may be ascribed to that cause. Extended operations are reported from the Buckingham district, where recently two new graphite mills have been erected. Another large mill is in course of construction near Wilberforce, Ont. The recent discovery of additional deposits in the Laurentian district, along the line of the Trondal, Bancroft & Ottawa Railroad, Ontario, seems to indicate that Canada will yet participate, perhaps in a considerable degree, in the world's production of graphite.

The principal difficulty encountered in the concentration of the graphite results from the similarity of the specific gravity of associated minerals.

The Canadian graphite deposits are generally found in one of three classes, namely: (1) Vein-like occurrences; (2) bed-like occurrences; (3) dissemination through the country rock.

In the first class the graphite constitutes the filling of fissures in gneiss, crystalline limestone, pegmatite, and granular eruptive rocks. These deposits have been mined in several localities in Canada; but in almost all cases their exploitation, because of the narrowness and irregularity of the veins, has not proved remunerative.

The principal features of bedded masses are that their general outlines and main direction conform with the stratification of the country rock; they form in the majority of cases disconnected layers, lenticular masses or chain-like accumulations, between the layers of the enclosing formation, giving off sometimes branches which again are accompanied by parallel lenticular masses or by widespread dissemination of graphite through the country rock.

The third class is in the form of fine films, scales, or plates scattered through certain portions of the country rock. This

Canadian Pacific Railroad, or 13 miles from Huberdeau, on the Canadian Northern Railroad, at a distance of about 80 miles from Montreal.

Physiographically the region is one of undulating hills not exceeding an altitude of 300 feet, and composed of flesh-colored gneiss.

Scant attention was at first paid to the accidental discovery of rock fragments containing flake graphite, and only when sev-



OUTCROPS OF GRAPHITE ORE, WIDTH 15 FEET

eral outcrops and large boulders were found was search for the main deposits made, and its existence established in the township of Amherst. Continued prospecting established the presence of a graphite-bearing zone, extending a distance of about 2 miles.

The principal rocks in this district are practically confined to the crystalline gneisses and limestones of the Grenville series. These crystalline limestones, gneisses, and quartzites are intruded by such rocks as pyroxenite, diorite, and diabase. The graphite deposits occur within eruptive rocks, striking between N E 62 and N E 70 degrees, with a dip of between 50 and 65 degrees to the east. Lenticular masses and pockets of graphite varying in size from a few inches to several feet in diameter, small veins, disseminations, branches, nests, kidneys, and irregular aggregations of the mineral, together with the gangue, constitute alternatively the bandlike portions of the ore zone. Work demonstrated that the larger bodies occurred within certain limits and along definite zones, which suggested that mining should be carried on by shafts and drifts. The present development work consists of a shaft 100 feet deep. At 40 feet one of the band-like deposits which appeared on the surface was encountered, and drifting thereon is now in progress. Another of these bedded masses, whose outcrop is located close to the shaft, was encountered at a depth of 90 feet. The graphitic portions of the zone on the surface are between 10 and 12 feet wide, in some places wider, the main portion consisting of graphite scales and flakes. The larger flakes, some of them 1 or 2 inches square, when freshly found are prevalently curved as though from pressure. They break in the direction of the platy structure into more or less angular aggregates, being composed of thin narrow foliæ of uniform width. Blocks of this almost pure graphite have been taken out measuring $1\frac{1}{2}$ to 2 cubic feet. This class of material is designated as "crude" or "cobbing" ore, and contains, according to the quantity of rock matter mixed with it, from 65 per cent. of fixed carbon and upwards. The quite pure crystals vary between 92 and 98 per cent. in fixed carbon. A portion of this crude material was crushed to flakes, and the latter analyzed. The fixed carbon in these flakes was found by Prof. Chas. H. White, of Harvard, Cambridge, Mass., to be 95.60 per cent.

Another kind of material taken from the deposits is designated as the disseminated variety, or milling ore. It is composed of streak and lense-like accumulations of graphite flakes of smaller size, the gangue consisting, in the main part, of feldspathic,



DERRICK AND SURFACE EQUIPMENT, AMHERST GRAPHITE MINE

occurrence is less desirable from a mining point of view than the other two, since it involves the handling of a large tonnage of rock. Many mines, however, owe their existence to deposits of this kind, and experience has shown that the size of these deposits renders their commercial extraction lasting and profitable.

The Amherst graphite deposits, presumably discovered about 10 years ago, are situated 12 miles from St. Jovite station on the

pyroxenic rock matter and wollastonite, or silicate of calcium. The Amherst deposits are remarkably free from objectionable admixtures which impede the successful extraction of the graphite from the gangue, or render the refined article unfit for the manufacture of most of the graphite products. There is no iron, mica, or pyrite (with its most objectionable sulphur) present; while lime remains in almost all the average tests so far made below the permissible minimum, that is, below 5 per cent. Most of the graphite is associated with feldspar or pyroxene, less frequently with wollastonite or calcite.

A selected sample containing much calcite gave, upon analysis by Prof. Chas. H. White, of Harvard, Cambridge, Mass., the following composition:

Moisture.....	.13
Carbonic acid.....	4.26
Other volatile matter.....	1.12
Free carbon.....	54.75
Ash.....	39.74
	<hr/>
	100.00

The mineral composition resulting then as follows:

Graphite.....	54.75
Feldspar.....	34.32
Lime.....	5.42
Carbonic acid gas.....	4.26
Volatile matter.....	1.12
Moisture.....	.13
	<hr/>
	100.00

From preliminary tests it is believed that the mill rock contains between 12 and 18 per cent. of graphite.

Some attention has been paid to concentrating and refining the ore, and experiments demonstrate that a combined dry and wet process will yield satisfactory results. A parcel of 1,220 pounds was subjected to a combined dry and wet process and the following results were obtained:

After the first grinding the following extraction was made:

	Kilos	Per Cent. Carbon
Coarse.....	132.25	95.4
Middle.....	244.00	93.4
Fine.....	20.30	93.9
And after grinding the millings:		
Coarse.....	88.80	94.1
Middle.....	167.20	93.0
Fine.....	56.00	87.0
	<hr/>	
	708.55	93.3

The crude material contained 66 per cent. carbon, which in the milling process was raised to 93.3 per cent., an increase of 41 per cent.

Other tests with the ore showed that the gangue materials are easily reduced to fine powder, which settles in water more slowly than the coarse graphite. A quantity of the material finely crushed and allowed to settle under water was found to contain more and more graphite as depth was attained.

From all the experiments it appears that the high-grade flake graphite can be separated in a dry state in a coarse condition, while the residue may be treated in water. Experiments have also shown that this graphite may possibly be separated from the gangue electrostatically.

Of the minerals making up the gangue of the graphite deposit the principal is feldspar. With the graphite it takes up over three-fourths of the deposit. Almost all the varieties of feldspar are present and all have a white glassy appearance and are frequently graphically interlocked with quartz grains. Under the microscope most of the feldspars contain fine needles of apatite, fine crystals of titanite and garnet, more rarely seapolite and muscovite. Pyroxene is freely distributed through the feldspathic gangue as augite, and hypersthene of a dark green color. Quartz is also frequently associated with the pyroxenes in small grains. Wollastonite is a frequent companion of the feldspar, and graphite scales and crystalline aggregations of graphite in wollastonite crystals are frequent. The brittle nature of the mineral facilitates its separation from graphite in a dry state. Calcite occurs in large crystals of rhombohedral form, the color being a pale green. It is irregularly but sparingly distributed through the gangue, its constant companion

being either wollastonite or graphite; the latter in scales of $\frac{1}{4}$ to 1 inch square, are often embedded in the larger crystals of calcite.

Those minerals which play a negligible part in the constitution of the gangue and occur only as scattered grains, small crystals, or minute scales through the pyroxene and feldspar, may be mentioned: Seapolite, garnet, titanite, zircon, muscovite, pyrite, apatite, leucoxene, biotite, monazite, and magnetite.

The origin of the graphite deposits is a question, but a few facts have been brought out during the course of the development work, and also by microscopical examination of thin rock sections, which might have a bearing on the distribution of the mineral through the rock matrix. In his treatise on "Graphite, Its Occurrence, Refining, and Uses," the writer has laid down the views of many authorities which were held at that time (1905) regarding this important subject, and in his opinion there is not one mineral whose origin has been the subject of such controversy or of so many hair-splitting theories as those pertaining to graphite. The most important of those theories is the one advanced by Weinschenk, that the source of the carbon in the case of eruptive rocks must be sought deep down in the earth. Weinschenk ascribes the formation of graphite in these deposits to the probable action of volcanic gases, probably of carbon compounds of the cyanogen group and of iron in the presence of carbon dioxide and water, all of which, having ascended along lines of fracture in the eruptive rocks, deposited graphitic carbon through chemical agencies; that is, after the crystallization of the rock minerals out of the intrusive magma. In the case of the Amherst deposits the graphite is solely confined to intrusions of the eruptive rocks; but so far there is no evidence that the carbon of the graphite was the result of volcanic gases acting along fracture lines. The writer has submitted thin rock sections of the graphitic gangue to examination under the microscope, and it can be clearly seen that the graphite is embedded in fresh feldspar, in quartz, and pyroxene, sometimes in well-defined crystals of these minerals. This naturally points to the presence of the graphitic carbon when the formation of these rocks took place; it shows further that the graphitic carbon was introduced before and not after the formation or crystallization of these minerals. This carbon was then very likely graphitized later on through pressure, heat, and other agencies which played, at one time, an important part in the formation of the rocks, and of which we know so very little.

栗 栗

Phonolith as a Fertilizer

Consul General Robert P. Skinner, of Hamburg, Germany, states that much interest has been aroused in Germany by the recent efforts of competitors of the potash syndicate to market a substitute fertilizer called "phonolith." The constituent proportions appear to be 2 per cent. of water, 50 per cent. of silicic acid, 7 per cent. of oxide of iron, 18 per cent. of clay, 4 per cent. to 5 per cent. of lime, 1 per cent. of magnesia, 8 per cent. to 10 per cent. of potash, and 6 per cent. to 8 per cent. of soda. There are strong differences of opinion in regard to the merit of this silicate of potash, some maintaining that it is of little practical value and others stating that the potash syndicate is alarmed and is endeavoring to discredit a valuable commercial article which can be sold on much lower terms than potash. It is claimed that the available supply of phonolith which is found in the Eifel Mountains, is practically unlimited, that it can be mined and ground for \$4.76 per carload, and that it is in fact now sold for \$35.70 per carload.

It is claimed that this fertilizer can be used upon such crops as potatoes, tobacco, grapes, fruit trees, and vegetables which are sensitive to potash. The first trials were made in 1906. Professors Wein and Hiltner, of Munich, state that phonolith should be used rather as supplementary to than as a substitute for potash fertilizing. Doctor Brenner, of Altona, on the other hand, looks upon phonolith as a direct competitor of potash. In commercial circles it is stated that the potash syndicate would not permit its dealers to handle phonolith and issued pamphlets declaring it to be without merit.

Mines and Minerals

Vol. XXXII—No. 10.

SCRANTON, PA.—MAY, 1912—DENVER, COLO.

Price, 25 Cents

PUBLISHED MONTHLY AT SCRANTON, PA.

ESTABLISHED 1881

INTERNATIONAL TEXTBOOK CO., PUBLISHERS

T. J. FOSTER, President S. P. ALLEN, Secretary E. H. LAWALL, Treasurer
RUFUS J. FOSTER, Vice-President and Manager

EUGENE B. WILSON, Editor ARTHUR J. HOSKIN, Associate Editor
WESTERN EDITORIAL OFFICE: 1221-1222 First Nat'l Bank Bldg., Denver, Colo.
CHICAGO OFFICE: 1006 Michigan Ave.

Entered at the Post Office at Scranton, Pa., as second-class matter
Address all business communications to MINES AND MINERALS, Scranton, Pa.
CABLE ADDRESS, "RETSOF, SCRANTON"

LONDON OFFICE: INTERNATIONAL BUILDINGS, KINGSWAY, LONDON, W. C.
SOUTH AFRICAN OFFICE: MANSION HOUSE CHAMBERS, ALDERLEY STREET,
CAPE TOWN.

NEW ZEALAND OFFICE: 63 DIXON STREET, WELLINGTON.
AUSTRALASIAN OFFICE: 83 PRIT STREET, SIDNEY.

SUBSCRIPTION RATES

Single Copies.....	25 cents
Yearly Subscriptions, including postage:	
To United States, Mexico, Cuba, Porto Rico, Hawaii, and Philippines..	\$2.00
To Canada.....	2.50
To all other countries.....	3.00

The date after your name on the wrapper is that of the month to which your subscription has been paid. If you do not want to continue your subscription after that time, kindly notify us.

Notice to discontinue or change of address should be sent to the Scranton office.

When notifying us of a change of address always give your FORMER as well as your present address.

TABLE OF CONTENTS

EDITORIAL—

Notes—The Anthracite Mining Law, 575—Comments on the San Bois, Okla., Disaster, 576—The Jed, W. Va., Disaster, 576—Nomenclature for Coal Briquets, 577—Not Much But Some..... 577

PERSONALS..... 577

CATALOGS RECEIVED..... 578

COAL MINING AND PREPARATION

THE JED, W. VA., MINE EXPLOSION..... 579

LIQUEFIED PRODUCTS FROM NATURAL GAS..... 583

PREVENTION OF SMOKE BY COMBUSTION..... 584

OBITUARY—

William Arthur Lathrop..... 585

BOOK REVIEW..... 586

MINE EXPLOSION AT McCURTAIN, OKLA., by A. A. Steel..... 587

COAL MINING NOTES..... 592

TRADE NOTICES..... 592

CORRESPONDENCE—

Method of Working a Vertical Coal Seam—Rubbing Surface of Airway—Specifications for Oil—Method of Shaft Plumbing—Iron Ore in Fulton County, Pa..... 594

THE COLORADO LIGNITE STRIKE SITUATION..... 595

BRUCEYTON, PA., EXPLOSION, by George L. Rice..... 596

DEEP COAL MINE SHAFTS..... 598

SAFETY GATE FOR TOP OF COAL MINE SHAFT, by A. A. Steel..... 598

PANTHER CREEK DRAINAGE TUNNEL..... 599

ANSWERS TO EXAMINATION QUESTIONS—

Mine Foremen, Anthracite, Pa., Pottsville, April, 1912..... 602

MINING SOCIETIES..... 604

ORE MINING AND METALLURGY

MINERAL DISTRICT OF RAYON..... 605

NECESSARY AMENDMENTS TO MINERAL LAWS..... 606

BLAST ROASTING OF GALENA..... 607

UNITED STATES COPPER PRODUCTION..... 610

GOLDFIELD, NEV., CYANIDE MILL..... 610

COPPER COMBINES AND MERGERS..... 612

CALIFORNIA NATURAL GAS LAW..... 612

SQUARE SET MINING AT VULCAN MINES, by Floyd L. Burr..... 613

REPAIRING A SPUR WHEEL..... 615

UNWATERING TRANSVAEAN MINE..... 616

CHINESE LAWS CONCERNING ACCIDENTS..... 618

COSTS OF MILLING IN LEADVILLE, by Oliver C. Ralston..... 619

TOPOGRAPHIC MAP OF THE UNITED STATES..... 619

WOODEN STAVE WATER PIPE, by Frank C. Perkins..... 620

TENNESSEE PHOSPHATE ROCKS..... 621

TREATING COPPER ANODE RESIDUES..... 622

PETROLIA, HENRIETTA, AND ELECTRA OIL FIELDS..... 623

SHAFT SINKING BY ELECTRIC SINKING HOISTS..... 624

DESCRIPTIVE MINERALOGY OF MICA..... 625

THE PASSING OF MINING AT FREIBERG..... 626

THE MIAMI, OKLA., MINING CAMP, by C. H. Plumb..... 627

COSTS AT LE ROI No. 2 MINES..... 628

FUNDAMENTALS IN TECHNICAL EDUCATION, by Regis Chauvenet..... 629

SQUIBS—

Boiler Water, 583—Lubricating Air Compressors, 595—Talc Imports, 1910, 606—Asbestos in Russia, 618—Manufacture of Oxygen, 623—Enforced Annual Assessment Work, 624—Asbestos Insulation, 628—Cerrium Tin Alloys, 632—Platinum in Russia..... 632

EVERY business man should send to the Bureau of Manufactures, Department of Commerce and Labor, Washington, D. C., for a copy of the 56-page pamphlet on "Factors in Foreign Trade." He needs it for reference.

采采

IT may be that the increased production of gold is the primal cause of the increased cost of living, but we haven't heard of any reformers who are willing to have their share of the gold production curtailed by a forced closing of the gold mines.

采采

THE poor coal miner excites the sympathy of thousands of coal consumers whenever he makes a demand for a larger wage, but the same sympathizers howl the loudest if asked to help increase the miners' wages by paying more for coal.

采采

THE past few months have again demonstrated the fact that, in their own minds, non-technical editors and others living in non-coal-producing localities, who do not know the difference between a coal mine and a hole in the ground, are fully competent to settle a wage dispute between the operators and the miners.

采采

THE "coal barons" who give 2,240 pounds for a ton to retailers and make a small profit on each ton, are veritable pirates in the minds of dwellers in the larger cities. The retailer who gives 2,000 pounds for a ton and frequently weighs the driver in, and who makes a profit per ton of from two to six times what the "coal baron" makes is a "respected citizen" in the minds of the same people.

采采

The Anthracite Mine Law

HON. CHAS. F. KING, a prominent contractor of Pottsville, Pa., who died on March 25, as a State Senator from the Twenty-ninth District, was the man who introduced in the Legislature of Pennsylvania, in 1883, the joint resolution for the appointment of a commission to revise the very crude and faulty Anthracite Mine Law enacted in 1871, which resulted in the very much more efficient law of 1885. The resolution introduced by Senator King was prepared by Mr. T. J. Foster, then editor and publisher of the *Mining Herald*, as MINES AND MINERALS was then known, who interested Mr. King in the matter. The latter, who represented an important mining district in fact, as well as in name, being a man of

superior ability and force, secured the passage of the joint resolution, and according to its provision the commission was appointed by the Governor. The mine law of 1885, which this commission framed, was a radical improvement on the former law, and with a few amendments, made from time to time, is the one now in force. This law is now in process of general revision. While the new revision will probably result in a few minor improvements, it is not likely that much change will be made in the basic features which were so carefully formed by a very competent commission.

來 來

Comments on the San Bois, Okla., Disaster

A CAREFUL reading of Professor Steel's report on the mine disaster at McCurtain, Okla., on another page, will show that there were conditions existing at the San Bois, or Chant mine, prior to the explosion and immediately after it, that merit severe criticism. From other sources than the report referred to, we have received information, that while the conditions in the mine were not as they should have been, all the fault does not rest on the mine management. The mine law of Oklahoma, in one particular at least, is to blame for a large share of the trouble. In fact, if the mine law was not radically wrong in this one particular, the conditions in the mine would not have been such as to make the explosion so far reaching and disastrous. If the law had been right in the portion referred to, it is possible that the explosion would not have occurred.

In the state of Oklahoma, the Chief Mine Inspector as well as the District Inspectors are elected to office, by the votes of all the electors regardless of their occupations, and worse still the candidates for inspectorships do not have to pass any examinations to show their competency. This law is therefore worse than that portion of the Anthracite Mine Law of Pennsylvania, which provides that candidates seeking election as Inspectors must have passed satisfactory state examinations. We have always condemned this portion of the Pennsylvania law as tending to lower the standard of Inspectors, but it is an infinitely better law than that of Oklahoma, which cannot be too severely condemned. From Professor Steel's report we find that shooting off the solid was the practice in all the rooms. It is true a permissible explosive was used, but that fact is no reason why shooting off the solid should have been permitted.

It also appears from Professor Steel's report that it was a common practice of the miners to disregard the "dead line" established by the fire boss, and that miners followed the fire boss into the mine, and were allowed to wait a short distance from the working face while he brushed out any accumulation of gas, which was not only liable to, but which did, ignite from the open lights carried by the miners. It also appears that immediately after the explosion, the entire stock of safety lamps intended for use in emergencies was out of order and unusable.

We have been informed that Fire Boss Crook, who was one of the unfortunate victims, was a very compe-

tent man except in the important matter of sobriety. He is said to have been addicted to the use of liquor and frequently entered the mine to perform his duties when far from sober. We would prefer to cast the mantle of charity over this unfortunate victim of the disaster, but reforms cannot be accomplished unless violations of law and common sense are laid bare. Here was a case with which the District Inspector, and possibly the Chief Inspector, was familiar. Why did they not use their authority to remedy so great an element of danger as the employment of such a fire boss? Why did they not use their authority to remedy some of the conditions existing in the mine? Why did not the Chief Inspector and the District Inspector get to the mine sooner, when they had knowledge of the disaster? Why did not Chief Inspector Boyle take charge of affairs when he did arrive at the mine, inasmuch as Superintendent Brown was incapacitated and there was no one to lead but Mine Foreman McAlpine, of a neighboring mine, who was competent, but who was hampered by lack of authority?

These and many other pertinent questions that will occur to mining men who read Professor Steel's report can be answered by the fact that in Oklahoma, political "pull" and an ability to get out votes are more essential in a Chief Mine Inspector than mining competency. Is there anything more ridiculous than a force of Mine Inspectors chosen by popular vote, when a majority of the voters have no conception whatever of what is required in a man competent to fill the position?

Mr. Boyle may be, and probably is an estimable man, and we have no criticism to make as to his general character, or the character of his force of District Inspectors, some of whom (as for instance Inspector Clarke, who arrived early at the mine and did excellent work), may be competent men, but from information furnished us, and from Professor Steel's report, we are justified in placing the greatest measure of blame for the San Bois disaster on the State of Oklahoma, as represented by the Legislature which passed its present mine law, and the Governor who approved it. If rational measures for the safety of mine workers and mining property are desired by mine officials and miners in Oklahoma, they cannot get to work too quickly to have the mine law so amended as to ensure the appointment by the Governor of men of high character and first-class mining attainments, as proved in competitive examinations, for inspectors. If the mine law is weak in other respects such men will soon point out the weak features and will suggest rational improvements.

來 來

The Jed, W. Va., Disaster

THE disaster at the Jed mine in West Virginia, following so closely on that at the Chant mine in Oklahoma, emphasized in an extraordinary degree the dangers incident to coal mining, and the necessity for greater precautions, in some instances, on the part of mine officials, miners, and state mine inspectors. While to the non-technical reader, or the one who carelessly

reads, the accidents may seem very similar and practically parallel in all their features, such was not the case.

At the Jed mine the discipline was far superior to that at the Chant mine. Manager Leckie, of the Jed mine, being a total abstainer himself, would not tolerate the excessive use of liquor in his subordinates, and his long experience in all positions from that of miner to general manager caused him to be an extremely careful man. The State Mine Inspectors were "on the job" at the Jed mine at the earliest possible moment after the explosion occurred, and they exercised their authority and leadership at once. This was quite in contrast with the case at McCurtain where, one mine inspector, and he from another district, was the only one who seemed to realize the full responsibility of his position.

The Jed mine was naturally a dangerous one. The mine inspectors realized it, and saw that the provisions of the law were enforced. The management cooperated with the inspectors in this respect. Nevertheless a disaster occurred. It was initiated by a gas explosion, but how the gas was ignited will never be positively known. Its presence in such large quantities was undoubtedly due to the freakish atmospheric condition prior to the accident. It would have been but a local explosion doing comparatively little damage if the second pair of cross-entries connecting the two portions of the mine had not been driven. This was regarded by Manager Leckie as an unnecessary passage way, and would not have been made had he been left to his own judgment. It was not regarded by him, or by the inspectors as a source of danger, or he would never have been persuaded to have it driven. The explosion was not a dust explosion. It was a gas explosion. The mine was not a particularly dry one, and the dust was dampened. It is true that the intense heat from the burning gas dried some of the dust and caused it to give off gas and ignite, but there were none of the peculiar features of a dust explosion. It was a most unfortunate accident for which it is impossible to place blame. The rescue work was speedily and well accomplished. The disaster was one that was entirely unforeseen, but, as in the case of all similar accidents, features were disclosed that point to lessons that if observed by mine managements generally, will tend to prevent similar occurrences.

乘 乘

Nomenclature for Coal Briquets

TO distinguish briquets made of anthracite from those made from bituminous coal the *Manufacturers' Record* suggests the words "artuminous coal" and "artacite coal." Possibly "artumite" and "artacite" would be an improvement as these words denote the nature of the briquet without the word coal. Although such words might be used to distinguish the two kinds of briquets, there still remains the particular shape to be defined; for instance, there would be oval artumite, truncated artumite, octahedral artumite, etc. After reaching this stage the binder would enter into the nomenclature, for instance, truncated asphaltic artumite;

isometric coal-tar artumite, octahedral-magnesite artacite; zone-like-sulphite artacite; etc. As the word "briquet" covers coal, binder and shape of the briquet it seems to be better than the suggested word besides is a special trade mark.

乘 乘

Not Much But Some

READERS of one of the popular magazines that last summer carried the autobiography of the ring-leader in the group of mining sharks mentioned in the appended news paragraph may now form the opinion that these men are fully as bad as the confession painted them. They are undoubtedly much worse. If the rest of his ilk throughout the world could be brought to justice, the mining industry would be immeasurably benefited. It is the regret of MINES AND MINERALS that these vampires on a legitimate, basic industry could not be given heavier sentences.

"New York, N. Y.—Pleas of guilty by George Graham Rice and Bernard H. Sheftels, of the brokerage firm of B. H. Sheftels & Co., brought to a dramatic close one of the longest trials on record in the United States courts here. With their associates, Charles F. Belser, Charles B. Stone, and Ralph E. Waterman, they have been on trial nearly 5 months for alleged conspiracy and the misuse of the mails to promote and sell mining stocks.

"Rice was sentenced to a year in jail, his sentence beginning December 29 last, when he was put in the Tombs after one of the jurors had been approached. With time off for good behavior, Rice will really spend but 6½ months in jail. Sheftels got off with a suspended sentence and the other three defendants went free, the indictments being quashed.

"The trial began on October 23, 1911, and witnesses from all parts of the country were brought here. Rice issued a statement saying: 'I pleaded guilty only when all my resources and those of my friends had been exhausted. I was up against it. By going on with the case to its conclusion next summer I would also have jeopardized the interests of my four codefendants, all of whom now go free.'"

乘 乘

Personals

J. W. Whitehurst is engineer for the Vanadium Mines Co. at Cutter, N. Mex.

M. C. Allen is assistant engineer for the Quincy Mining Co., Hancock, Mich.

Val DeCamp is with the Pacific Copper Co. in the Crown King district, Ariz.

George F. Strohl is chief engineer for the Tennessee Copper Co., Ducktown, Tenn.

Albert G. Wolf is mine superintendent for the Telluride Leasing Co., Telluride, Colo.

Otto Herres, Jr., is assistant for the Utah Fuel Co., with headquarters at Castle Gate, Utah.

S. J. Clausen has been examining mining property and cleaning up an old mill near Bland, N. Mex.

A. H. Purdue, former State Geologist of Arkansas, is now State Geologist of Tennessee with headquarters at Nashville.

A. S. Gable has been appointed district superintendent of the

Shenandoah District of the Philadelphia & Reading Coal and Iron Co.'s collieries.

Jean McCallum, mill foreman for the Chino Copper Co. at Hurley, N. Mex., spent 2 weeks vacation at his Denver home.

Charles S. Ramsey has been appointed superintendent of the Dora mines of the Pratt Consolidated Coal Co., at Dora, Ala.

A. F. Hallett is foreman in the cyanide mill of the Honduras and Rosario Co., San Juancito, Honduras, Central America.

Lyman P. Hammond succeeds E. L. West as general manager of the Central Colorado Power Co., with headquarters in Denver.

Francis Drake, of London, England, has gone to Rhodesia to act as consulting engineer for Messrs. Lewis and Marks, of London.

J. J. Shuck, superintendent for the Moose Smelting and Refining Co., of Alma, Colo., recently spent some time in Denver, on business for his company.

Charles W. Merrill, of San Francisco, has been in Colorado, adjusting final matters of ore treatment at the Colorado City mill of the Portland Gold Mining Co.

Norton H. Brown is general superintendent of the Frontenac Consolidated Mines, Ltd., and the Topcka Consolidated Mines Co., with offices at Central City, Colo.

William E. Corey is a member of the boards of directors of the International Smelting and Refining Co., the Inspiration Consolidated Co., and the Greene-Cananea Mining Co.

D. G. Miller is superintendent for the United Gold Mines Co., Congress, Ariz. Walter W. Barnett is assayer and precipitation foreman in the 30-ton cyanide plant of this company.

D. C. Kelso is superintendent for the Beck Mining Co., operating the Duncan mine at Atlantic City, Wyo. O. R. Taggart, formerly mill foreman for the same company, is in Denver.

Fred Jones, engineer for the Portland Gold Mining Co., Victor, Colo., recently made an examination of an extensive mining property on North Star Mountain, between Breckenridge and Alma, Colo.

Charles J. Moore, of Denver, has recently made a thorough examination of the London Mine, Alma, Colo., for men who are about to reopen this property at much greater depth by driving a long cross-cut adit.

William G. Haldane, assistant professor of metallurgy at the Colorado School of Mines, was married, February 28, to Miss Lorena Beaver, in the Central Presbyterian Church, Denver. His home will continue in Golden.

Franklin Guiterman, general manager of the American Smelting and Refining Co., has moved his headquarters from the general offices of the company in Denver to the New York City offices, where he will be in closer consultation with the principal officials.

R. M. Henderson, general manager of the Wellington Mines Co., of Breckenridge, Colo., who met with a serious accident last fall is now slowly recovering his health at St. Joseph's hospital, Denver, Colo. He has suffered the loss of one leg, which was amputated at the hip.

N. P. Turner has resigned his position as chief engineer of the Cuba Railroad. In association with L. D. Moore, of New York, he will take up mining and general engineering and exploration in the West Indies, Central and South America, with headquarters for the present at Hotel Camaguey, Camaguey, Cuba.

H. A. Everest is manager and superintendent of a new incorporation operating at Coalgate, Okla., under the title of the Hazelton Coal and Mining Co. He has been conducting examinations of Texas geology and states that he expects to prove the existence of an oil field in the region between the Pecos River and the mountains to the west.

George Watkin Evans, mining engineer, of Seattle, Wash., who is well known to the readers of MINES AND MINERALS, has resigned from the State Geological Survey, to open an office as consulting engineer. Mr. Evans has been for a number of years

Chief of Coal Surveys in Washington. He accompanied Secretary Fisher on his trip of inspection in Alaska.

Redpath and McGregor, of Douglas, Ariz., are making plans and supervising the construction of the new smelting plants for the Calumet and Arizona Mining Co., at Douglas, Ariz.; the Arizona Copper Co., Ltd., at Clifton, Ariz.; and the United Verde Copper Co., at Jerome, Ariz. They are also designing the Inspiration Consolidated Copper Co.'s proposed mining and concentrating plants.

The following have recently been added to the membership of the American Institute of Mining Engineers: E. F. Douglass, Keweenaw Bay, Mich.; Willis E. Everette, Tacoma, Wash.; John A. Fulton, Melones, Cal.; William J. Hall, Wallace, Idaho; John W. H. Hamilton, New York, N. Y.; William H. Hendrickson, Salt Lake City, Utah; Oscar B. Hofstrand, Wallace, Idaho; William M. Hoover, Hazleton, Pa.; Charles Janin, San Francisco, Cal.; Zachariah Jones, Republic, Wash.; Sidney J. Kidder, Blair, Nev.; John W. Logan, Conshohocken, Pa.; William C. Madge, London, E. C.; Edward Manion, Terry, S. Dak.; William H. Merrett, Surrey, Eng.; H. Alfred Millard, New York, N. Y.; Ralph T. Mishler, Yzabel, Sonora, Mex.; Phil H. Moore, Toronto, Ont.; Harry W. Newton, Republic, Wash.; Arthur W. Paterson, Lewiston, Idaho; Samuel L. Pearce, Los Angeles, Cal.; George S. Rayner, Cambridge, Mass.; John V. W. Reynders, Steelton, Pa.; John B. Schmettenhelm, Butte, Mont.; Allan E. Sedgwick, Mexico, Mex.; Clarence L. Severy, Antofagasta, Chile; Otto C. Wolf, Philadelphia, Pa.; Ernest A. Wraight, Waver-tree Road, Eng.

乘 乘

Catalogs Received

CANTON FOUNDRY AND MACHINE Co., Canton, Ohio, Booklet F, Turntables That Turn, 8 pages.

CHICAGO PNEUMATIC TOOL Co., Chicago, Ill., Bulletin E-19, Universal Electric Drills Operating on Direct or Alternating Current, 8 pages; Bulletin E-20, A New Line of Electric Drills for Heavy Duty, 8 pages; Bulletin E-21, Duntley Track Drill, 8 pages; Bulletin E-23, Air-Cooled Direct-Current Drills, 8 pages; Catalog No. 40, "Rockford" Railway Motor Cars, 24 pages; Catalog No. 37, Stone Tools, 23 pages.

E. I. DUPONT DE NEMOURS POWDER Co., Wilmington, Del., The Agricultural Blaster, 16 pages.

DENVER ENGINEERING WORKS Co., Denver, Colo., Bulletin No. 1055, Improved Richards Pulsator Classifier Inverted Type, 8 pages.

DE LAVAL STEAM TURBINE Co., Trenton, N. J., Catalog "D," De Laval Steam Turbines, Multi-Stage Type, 117 pages.

GENERAL ELECTRIC Co., Schenectady, N. Y., Bulletin No. 4911, Type F Form K20 Oil Break Switches, 16 pages; Steam Boiler Economy, 16 pages; Small Turbo Generator Sets, 5 kilowatt to 300 kilowatt, 16 pages.

GARDNER GOVERNOR Co., Quincy, Ill., Gardner Duplex Steam Pumps, 52 pages.

HOYNES SAFETY POWDER Co., Williamson Building, Cleveland, Ohio, Hoynesite, Directions for Use of Hoynes Safety Powder, 28 pages.

INDUSTRIAL INSTRUMENT Co., Foxboro, Mass., Bulletin No. 60, Indicating Gauges for All Purposes, 16 pages.

INGERSOLL-RAND Co., 11 Broadway, New York, N. Y., Form No. 4204, "Arc Valve" Tappet Rock Drills, 16 pages.

H. KOPPERS, Joliet, Ill., Brochure No. I, Operating Gas Engines on Coke-Oven Gas in Parallel With Steam Turbines, 8 pages.

KEYSTONE DRILLER Co., Beaver Falls, Pa., Catalog No. 6, Downie Deep Well Pumps, 78 pages.

W. S. ROCKWELL Co., 50 Church Street, New York, N. Y., Catalog No. 14, Rockwell Furnaces, 46 pages.

STURTEVANT MILL Co., Boston, Mass., Sturtevant Laboratory Crushers, 8 pages; Sturtevant Ring-Roll Mill, 8 pages.

NATIONAL ELECTRIC LAMP ASSOCIATION, Cleveland, Ohio, Bulletin No. 101, Lamp Efficiency, 23 pages.

COAL MINING AND PREPARATION

The Jed, W. Va., Mine Explosion

Probably a Gas Explosion Influenced by Change of Barometer and Local Conditions in the Mine

On the morning of March 26 at about 8:30 A. M., a mine explosion occurred at Jed, McDowell County, W. Va., which caused the death of 82 men. The mine is situated on Tug Fork of Tug River, about 2 miles from Welch and is operated by the Jed Coal and Coke Co. It is a shaft mine working on No. 3 Pocahontas seam. The main or hoisting shaft is 32 ft. x 14 ft. over all, has three compartments 10 ft. x 12 ft., and is 285 feet deep. For 85 feet from the collar down it is lined with con-

Dust explosions are much more damaging than gas explosions, which would be local in bituminous as in anthracite mines were it not that the precursive wave stirs up dust, and that the concussion wave following draws the fine dust particles into its vortex where the flame following ignites the particles and distills gas which increases the force of the precursive wave.

The Jed mine gave off gas, but hitherto conditions have been such that it has been diluted and rendered harmless. It is presumed therefore that something happened which deranged the air-current, caused short-circuiting, and the accumulation of gas, which was fired later by an open light. While some mine managers are of the opinion that a fall in barometric pressure has little to do with gas exuding from a coal face, most managers recognize the fact that a decrease of atmospheric pressure

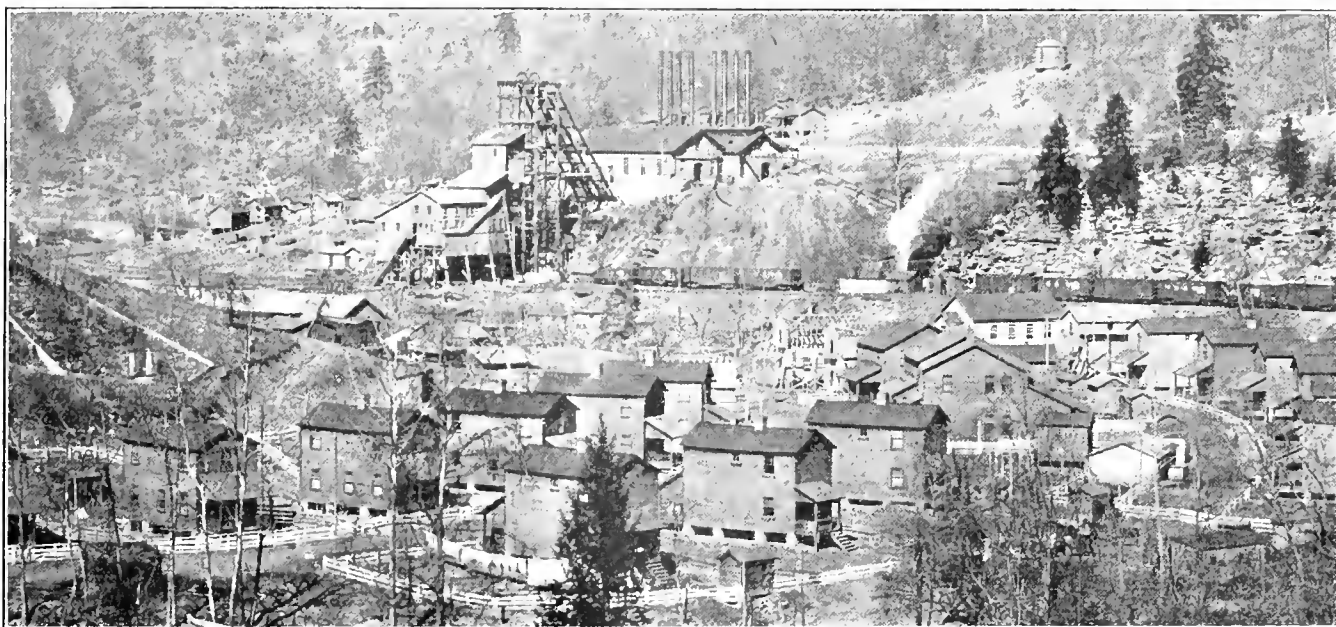

FIG. 1. TOWN OF JED, W. VA., AND THE SURFACE WORKS AT THE MINE

crete, the remainder of the distance being in solid rock. The upcast shaft 200 feet from the main shaft, is 14 ft. x 18 ft. at the collar, is supplied with stairs for exit in case of accident to the hoisting gear, and is connected with a 6' x 24' steel Guibal fan of the Vulcan Iron Works make by a sheet-steel airway which is supplied with suitable explosion doors. Both the fan casing and fan house are also of steel. The force of the explosion broke two blades in the fan, but did not blow the explosion doors wide open or put the fan out of commission, a fact which greatly aided in the recovery work.

In Fig. 1 is shown part of the surface arrangement of the mine plant which is complete and up to date. With the exception of the slight injury to the fan the plant suffered no damage from the explosion, the cages even remaining in their normal condition in the shaft. That the force of the explosion was not severe is further corroborated by the fact that no mine cars inside were blown from the tracks or even damaged; consequently it is presumed on good evidence that the initial explosion was due to gas being ignited, and that while dust undoubtedly played some part in generating afterdamp, it did not, owing to its damp condition, add greatly to the force of the precursive wave or blast of air naturally driven ahead of the flame.

will naturally increase the exudation of gas, and some have proved it to their satisfaction.

One-half inch fall in barometer when the temperature is 42° F. is equivalent to taking off .245 pound pressure from each square inch of coal face, and if the coal has pronounced cleavage this change in pressure will undoubtedly permit gas to exude more rapidly than when held back by higher pressure. When it is considered that this slight variation extends over the entire mine and that the nature of gas is always to expand, it becomes evident that ignoring the barometric readings is a mistake.

The barometric pressure on March 24, 2 days before the accident was 28.90, on the morning of the 25th the barometer stood at 29.45 inches of mercury, and at 5 A. M. on the morning of the accident the barometer registered 29.3 inches of mercury. Bearing in mind that no work was done Sunday the 24th, and little done on the 25th through lack of cars, it would seem no more than natural that a difference of .25 pound pressure per square inch would start the gas oozing from the coal cleavage, and considerable quantities could collect in various parts of the mine.

Jed mine as shown in part in Fig. 2 is worked by the panel

system. The No. 3 Pocahontas coal bed at this mine is 5 feet 3 inches thick, capped on an average by 18 inches of draw slate; 2 inches of coal, above which is 6 inches of black slate; then good sandstone roof. In the entries the entire 7½ feet of coal and roof material up to the sandstone is removed, in the rooms, however, the draw slate, coal, and black slate are held up by props placed every 4 feet. The slate is liable to fall after exposure to air, and the concussion due to the explosion undoubtedly caused considerable of the material to fall prematurely and cover a number of men. It is quite possible also that this may have caused some deaths. During the last 4 years, although the mine worked in night and day shifts, but three men have been killed by falls of roof, which compares favorably with mines having good roofs, and is at variance with the press statement issued by Doctor Holmes, Chief of the Federal Bureau of Mines, who is quoted as saying on March 30 that "such accidents as the one in the Jed Coal and Coke Co.'s mine are due primarily to the fact that American laws do not require adequate roofing in coal mines, do not require operators to dampen the coal dust, and do not compel them to drive out combustible gases * * *. In Great Britain and France roof beams and supports are placed 3 feet apart. In this country no standard exists at all." No law so far as the writer knows in Great Britain or elsewhere compels the operator to place supports 3 feet apart, and no standard exists to that effect any more than in the United States. In point of fact the accident at Jed was not due to lack of props, and the coal mines of England and France are not free from gas and dust explosions.

The coal mined at Jed is the celebrated Pocahontas semi-bituminous coking coal having about the following average analysis: Moisture, 1.01; volatile matter, 18.81; fixed carbon, 74.99; ash, 5.19; sulphur, .787. The Jed Coal and Coke Co. does not make coke but ships all coal mined.

The main heading entries No. 1 and No. 2 are separated by a pillar 200 feet wide, thus dividing the mine into two panels. Each of the main heading entries is composed of four entries 20 ft. x 7.5 ft., the manways and haulways being intakes and the other two entries return airways. The two panels are connected by the cross-entries *A* and *B*. Mr. William Leckie, the manager, did not intend to drive the pair of cross-entries at *B* but was prevailed upon to do so, and now recognizes that it was a mistake, for the explosion traveled through the return cross-entry of *B* into the No. 1 main heading entries and so on to cross or butt entries, where most of the men were poisoned with the afterdamp. Cross-entries are turned on the butt to the right from No. 1 main headings and to the left of No. 2 main headings every 400 feet. From these butt entries rooms are turned and worked to the rise until they break through to the next pair of butt entries. All work on the main headings is to the rise; however, the No. 1 butt right entries are not uniformly to the rise as there are gradual swags in the roof with a depression in the floor to correspond, thus forming a channel in which water accumulates. No. 2 butt left entries will probably meet with the same conditions, as they are general throughout the Pocahontas field. All rooms are driven 20 feet wide at an angle to the butt entries to take advantage of the cleavage. The unevenness of the breakthroughs is due to leaving large pillars and to the difficulty experienced in centering and keeping the ribs straight when using machines entirely for undercutting.

The machines, both Jeffrey and Goodman, are worked by the night shift, and make an undercut between 5 feet and 6 feet at about 6 inches above the floor. The miners drill the holes, charge them with permissible explosives and tamp the charge with clay brought into the mine for the purpose. This is done under the direction of shot firers. Before the shots are fired the coal left on the floor by the machines is removed or "snubbed" from under the coal by the miners, who use picks and shovels for the purpose, the object being to give more of an undercut,

and hence a fall that will permit the coal to roll over and break as in pick undercutting.

All shots are fired by experienced men who use magneto-electric batteries for the purpose. The three shot firers commence at 7 A. M. in the morning, and continue to shoot until about 2 P. M. The coal is loaded into cars by miners; the cars being gathered by 13 mules and delivered at the turnouts, from which places they are hauled to the shaft by Jeffrey electric locomotives.

The air stoppings on the main heading entries are concrete, those on the cross-entries, except near the face, are of dry masonry 4 feet thick, with hand-laid stone on the outsides and fine material between them. These butt stoppings are pointed with cement mortar to make them air-tight. Quite a number of these stoppings were blown down, showing that they were not sufficiently strong to answer the purpose for which they were intended. The air stoppings between rooms are of boards.

A peculiar feature found in connection with the destruction of air stoppings observed in recent explosions is that some are pushed away from the precursive wave, others are drawn toward it, and again still others appear to have been forced in both directions. Some of the cross-overs were wrecked, which in this case was probably due to their being reduced to 6 feet in width.

Many mines could be made safer by driving the cross-overs in rock and making them of the same sectional area as the entries they serve. Since the safety of the men shut in the mine after an explosion depends upon the air crossings and the air stoppings remaining intact, these devices cannot be made too strong. In almost every explosion that has occurred in late years comparatively few of the fatalities have been due to violence, the most of them being due to deadly afterdamp. Thirteen men came from this mine alive, some of whom did not know there had been an explosion. Three men on No. 2 butt right heard a report like a pistol but their lights were not blown out. They went to the intake, that is No. 1 main entry haulway, twice, but seeing smoke retreated. The door at *C* on the butt entry just off of the main haulway was not disturbed, neither were No. 1 main entry doors. The door boy attending to these doors escaped but afterwards died on the surface. At the time of the explosion the electric locomotives were standing at about *D* and *E* on the No. 1 haulway, and the motor men and helpers escaped by traveling through the butt entry to the right off this haulway and following the fresh air to the hoisting shaft. The two bottom men were not injured, and some of these men notified the two pumpmen who were in the vicinity of the air-shaft. Those who escaped were all outside the zone of disturbance.

While the cross-over at *F* on No. 1 haulway was knocked down, the precursive wave seems to have stopped at *G* at the junction of the north heading entry and the No. 1 haulway. On the No. 2 main heading the precursive wave seemed to have stopped at *H*, the junction of the haulway and the slant entry from the north heading entries. In both instances it will be noted that the explosion stopped when going toward fresh air, which is a strong argument against a dust explosion, for in that direction there would be oxygen to feed combustion. The direction of this explosion was not with the fresh air-current but against the return, and this suggests that the return air was charged with more or less gas.

It is presumed from careful investigations made by P. A. Grady and William Nicholson, mine inspectors, that gas accumulated in the vicinity of room 8 on No. 1 butt left entry off from No. 2 main heading. The coroner's jury were also so convinced by this evidence that their verdict stated that room 8 was where the explosion started. It then traveled through *A* from No. 2 butt left entries, to No. 1 main headings, also up No. 1 airways to the cross-entries *B* and to No. 1 main headings and rooms. It probably traveled down the return airways of No. 1

main headings, for the cross-over at I was broken down and it was from this direction that the smoke came to the men who were escaping from No. 2 butt right entries, for they were compelled to retreat from the mouth of No. 2 and No. 1 butt right entries.

It was the custom at Jed to water some part of the mine every day and in addition to this the mine was wet. Tug Fork flows over one part of the mine and there is more or less general seepage throughout, although there are dry places also. In almost any part of the mine if one rubs his finger on the wall it will be smeared with wet dirt. To lift the water from this mine two Jeanesville pumps have been installed, one having

which practically closed the mine for that day, and written recommendations were left that work should not be resumed in the dusty sections until the dust had been wetted. These recommendations were followed by the management, and this opportunity is taken to comment on the watchfulness and care taken by Inspector William Nicholson of this district to prevent a disaster of this kind. Not relying entirely on his own judgment, he more than once called Inspector P. A. Grady to consult and examine mines with him in case of doubt.

At the time of the last state inspection the fan was running 75 revolutions per minute and was furnishing 125,000 cubic feet of air per minute with a water gauge of 1½ inches. This

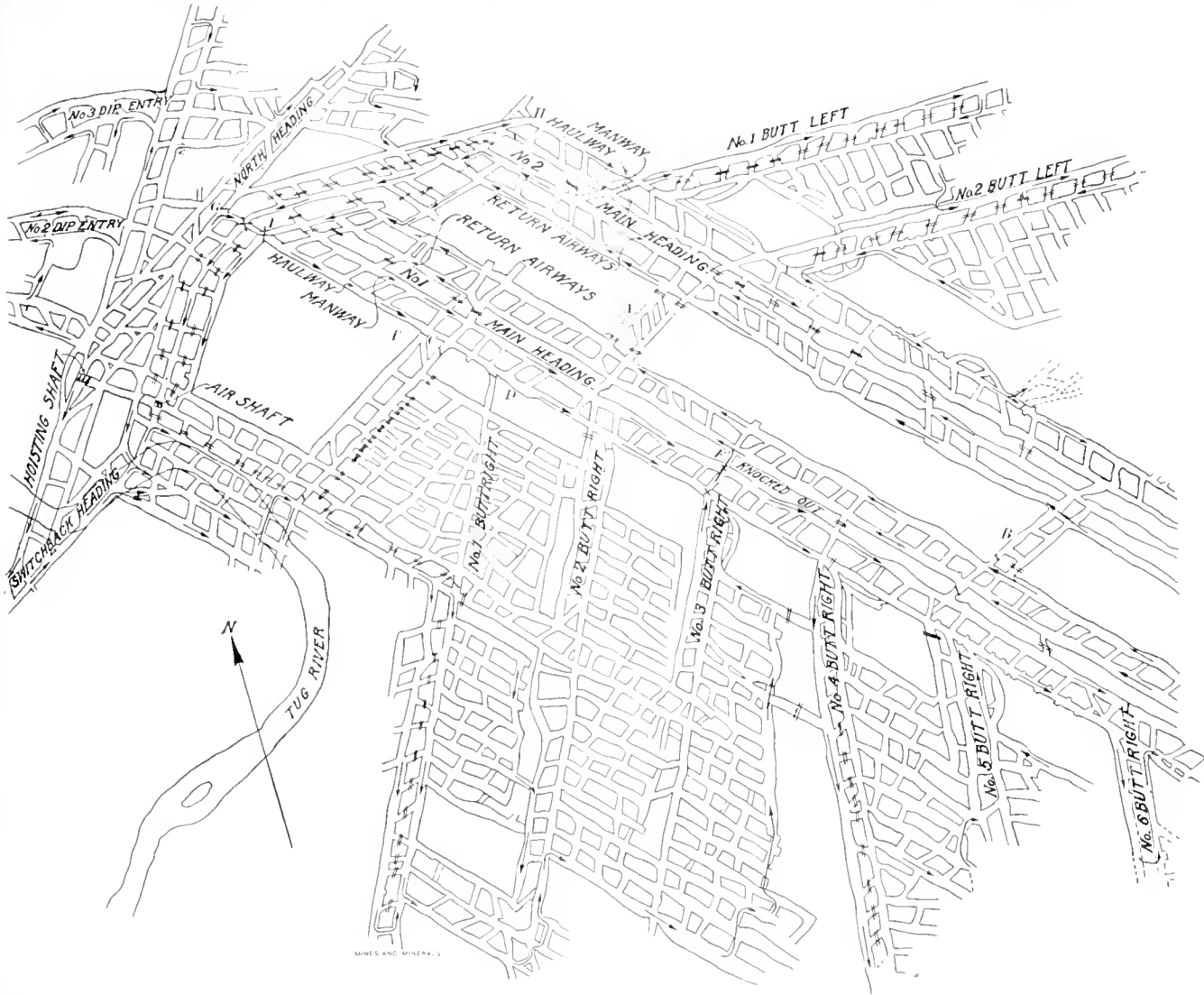

FIG. 2. MAP OF JED MINE, WEST VIRGINIA

a capacity of 500 gallons per minute and the other 1,000 gallons per minute. These are at the bottom of the upcast shaft, the smaller one being used as an auxiliary. In the mine there are two gathering pumps which deliver to the shaft pumps. In the upcast there is a water ring and a pump of 250 gallons capacity which supplies the town with water.

According to trustworthy reports, from January 19, 1911, to February 1, 1912, there were eight regular state inspections made of this mine. On six of these inspections complaint was made of the presence of coal dust. Recommendations were made that the coal dust be always kept wet, and to help in doing this the inspectors advised that steam be turned into the intake airways of the mine. During one inspection the mine was considered to be in a dangerously dusty condition and nearly all of the miners were ordered from the working places,

quantity of air for the 100 men and 13 mules usually employed on the day shift was abundant and complied with the West Virginia law, which demands 150 cubic feet per man as a minimum in gaseous mines, and more if the inspectors demand. The air-current was split three times, one split going to the dip entries, another to No. 1 main headings, and the third to No. 2 main headings. On January 29, 1912, a sample of mine air taken at the foot of the upcast gave on analysis four-tenths of 1 per cent. of marsh gas, or, with 125,000 cubic feet of air passing per minute, about 500 cubic feet of methane CH₄ or marsh gas was given off per minute. In 1908 when the mine was much less developed seven-tenths of 1 per cent. of methane was found in the upcast, and it is reasonable to suppose that conditions could arise when this would be duplicated and more.

Inspectors Grady and Nicholson, without denying the possi-

bilities of such an occurrence, state correctly from the evidence that the mine in 1912 has four times the area it had in 1908, and that the later analyses show that it takes a much larger area to generate the same percentage of gas, viz., 500 cubic feet of pure methane per minute. This they attribute to the development extending in a direction where the coal has less cover and where it is known to contain less gas.

On the 25th of March, the day previous to the explosion, the men quit work at 2 p. m. owing to a shortage of railroad cars. This left mine cars standing in the working places, and when the men entered for work on the morning of the 26th there was no necessity for going directly to the working places, as all the cars were loaded, and nothing could be done till they were replaced by empties. In the first left butt off No. 2 entry four bodies were found near a tool box standing near No. 8 room. The nearest any bodies were found to the working faces in this section were those in No. 8 room which were about 40 feet back from the face.

To ventilate No. 1 butt left, the door is placed on the main entry which turns the air into the air-course No. 1 left butt up to the last breakthrough, from which it circulates back out the entry and rooms. Leaving this door open for any length of time would cause an accumulation of gas in rooms 8, 9, and 10. The stoppings in the breakthroughs between the room entries and the main entries are here constructed of planks, and a fall of draw slate could break one of them down, thus causing a short-circuit of the air and the accumulation of a body of gas. It is necessary in this mine to conduct the air-current to the working faces by means of check-doors on the entries, stoppings in room breakthroughs, and brattices from the last breakthrough to the face. The breaking down of any one of these would cause an accumulation of gas. It is quite evident that a body of gas accumulated from some one of the causes above mentioned, and it was either ignited where the men were sitting with naked lights, or the men working in No. 8 room walked into it with naked lights on their heads.

It is the opinion of the inspectors that the amount of gas ignited could have accumulated from the time the fire boss made his examination until the explosion occurred. The assumption that the gas could have been ignited by a blown-out shot is discarded, and there is no evidence to show that any shots had been fired in that section on the morning of the explosion; further, the mine foreman stated that machines had not undercut that section the night before. It was the opinion of the coroner's jury, and also of the state mine inspectors, and others, that the explosion originated in the vicinity of No. 8 room first butt left, and was caused by the ignition of a body of firedamp whose heat distilled sufficient gas from the coal dust present to spread the explosion almost over the entire mine.

All the evidence in the mine goes to show that the explosion started in No. 2 panel and traveled over to the No. 1 panel, exhausting itself before it came to No. 2 butt right entries. The workmen in these latter entries, as stated, came out uninjured by going through the intake air-current from the switchback.

In comparing this explosion with other explosions that have occurred recently in which dust was an important factor, it is noticeable that it did not attain the same violence as some of the other explosions. Inspectors attribute this to the falls of slate in the air-courses and worked-out rooms previous to the explosion. The roof material, as stated, is held up in the rooms by props when the coal is being mined, but falls in a short time afterwards, covering up all dust on the bottom. They intimate that the explosive wave in passing over these numerous falls was checked on account of less coal dust existing. It attained sufficient violence, however, to blow out the overcasts and the masonry stoppings on the main entries to within a short distance of the shaft, and usually the damage from explosions is on the entries rather than in the rooms. The inspectors claim that "the method pursued to keep the dust down in this mine was ineffective. By using the water box and mule too

much dependence had to be placed on the human factor, with the result that thorough sprinkling could oftentimes be neglected." If the intake air-current of the mine had been raised to a higher temperature than the mine, and the moisture injected into it, so that the air-current at all times could serve as a vehicle to carry moisture to all parts of the mine, or if pipes were laid into the workings so that sufficient water could be had at all places to wash down the roof, sides, and bottom, the inspectors believe that an explosion so general as this one would not have occurred.

While the mine inspectors may be right in their conclusions, the movement of an explosion is in the line of least resistance, and if this had been a dry mine the dust explosion would have taken the shortest course to the shafts. In this case, however, the explosion ceased in three parts of the mine because the precursive wave did not draw sufficient dust into the concussion vortex to supply the flame following with fuel. When the flame ceased just before it reached No. 2 butt right, it had practically traveled three-fourths of the entire mine and still there was not sufficient dust inflamed to carry it further against fresh air. This suggests that the mine could not be assigned to the "dusty class" at this particular time. The writer believes the explosion was one of gas and was kept alive by gas which was exuding from the old and new working faces all over the mine and traveling in a diluted state in the return airways.

The precursive wave in taking the direction into the mine against the return had more resistance to overcome than when traveling toward the fresh intake, consequently there was some inducement besides the distillation of gas from dust preceding the flame. Undoubtedly gas was distilled from the coal dirt, but the dust would have exploded had it been fine and dry, which argues that the mine was damp throughout. The intake air contained no gas and was able, with the damp condition of the mine, to cool the flame in the three portions of the mine mentioned. The indication of an explosion on the surface was a rush of air and smoke from the mine openings. The foreman who was at the bottom of the shaft gave orders to the top man, and the cage standing at the top was lowered. O. M. Knauff, superintendent, descended on this cage with his safety lamp and sent up 10 men who had gathered in the vicinity of the shaft after the explosion occurred.

Material for erecting temporary brattices was quickly assembled and in about one-half hour men with safety lamps commenced erecting temporary air stoppings. They reached the door at the first main entry and found the door boy alive, but unfortunately he died shortly after reaching the surface.

In the meantime word of the disaster was sent to the United States Coal and Coke Co., to the state mine inspectors, the United States Bureau of Mines, and neighboring collieries.

The first rescue party was composed of company men of the night shift who had been called from their beds. These and some of the survivors took the brattice boards and brattice cloth collected and started to restore the air-current in No. 1 main intake with temporary brattices as they advanced.

Another party commenced work on No. 2 main intake and constructed temporary brattices with boards and canvas. The party on No. 1 main reached No. 4 butt right without great difficulty, but here their progress was blocked by gas and they could go no farther. Inspectors P. A. Grady, of Williamson, and William Nicholson, of Bluefield, arrived at the mine about 10:30 a. m. and immediately took charge of the recovery work.

When the rescue party on No. 1 main intake reached No. 4 right butt, it was decided that those men who were caught beyond this entry must all have been smothered by the afterdamp, so part of the air was cut-off from No. 1 headings and an increased quantity sent into No. 2 headings and rapid progress was made in recovering the bodies. The air was conducted across to No. 1 main heading from No. 2 so that one current circulated through the mine. By Wednesday the entire mine

had been explored and many of the bodies recovered, but quite a number were located that could not be easily removed on account of the roof falls. There was not much trouble experienced by the systematic work and relay crews in driving the afterdamp from the mine. On the day of the explosion, and from the time they arrived, Messrs. Grady and Nicholson worked without rest until late at night, when William Leckie, general manager, Arthur Mitchell, mine inspector, and William Williams, a miner, experienced in recovery work, relieved them. The helmet men from the Bureau of Mines were extremely cautious in venturing into the rooms for fear probably that the roof would fall.

The impression prevails among miners and the general public that the crews on the Federal Bureau of Mines Rescue Cars are for the purpose of rescuing entombed miners, and that the helmet men who are carried to the scene of an explosion are to risk their lives in so doing.

While ostensibly the cars and crews were for this purpose, they proved by experience to be best suited for instruction in first-aid work and in the use of oxygen helmets. Helmet men encased in the heavy cumbersome apparatus are unable to do more than exploratory work and possibly hang a brattice cloth. There is no reason why these car crews should risk their lives by going into strange mines where roof is liable to fall to pull out men; in fact, two or three ambitious members of government car crews have lost their lives in attempts of this kind, while none of the crews so far as we are able to learn have saved a single person.

This explanation is made because in every instance these car crews are made the targets of adverse criticism if they are not so foolhardy as to jeopardize their lives by exceeding their capabilities. Considerable more might be said on this matter but space will not permit at this time.

This, it is believed, makes the eleventh mine explosion in the Pocahontas field, and demonstrates conclusively that the field is dangerous. Mr. McQuail, an old operator in that region, is quoted as saying that "the gas is more vicious than in other fields." However, be that as it may, it is to be hoped that each operator will anticipate such catastrophes and guard against them by continual watchfulness. It is also suggested that the operators club together and hire some one to follow barometric and hygrometric changes, that they may be kept fully informed on weather conditions.

Mr. Leckie desires to publicly thank all those who so unselfishly rendered prompt and efficient aid in recovering the dead and the mine. Although suffering from lack of rest and from worry, besides being bothered by the writer, he was frankly emotional when expressing his obligations for their kind considerations.

來 來

Liquefied Products From Natural Gas

In outlining their investigations on natural gas, Irving C. Allen and George A. Burrell, of the Bureau of Mines, state:

By fractionating natural gas, either during or after liquefaction, four products can be commercially obtained. Roughly, these four products may be described as follows: (1) The gaseous product, the common natural gas of commerce; (2) the semiliquid product, known as the new "wild" product, which should be used only as a liquefied gas and should be held in high-pressure steel containers only; (3) the light liquid product, or light gasoline used for blending with heavy naphthas; and (4) the heavy liquid product, or ordinary high-grade gasoline.

The possibility of handling the second product in the way that Pintsch and Blau gases are handled, enabling small towns, hotels, and country estates to have the advantage of gas illumination, manifestly opens a new field of comparatively great importance in the natural gas industry and should add materially

to the investments made in the so-called "natural gasoline" industry.

The liquefaction of gases by pressure is not a new industry, but only recently has its application to natural gas been recognized as practicable.

Up to the last 2 years the general practice in the manufacture of liquid natural gas was to make the product by compression of the gas in single-stage compressors operated at a pressure of 150 to 300 pounds per square inch. The one product obtained, so-called natural gasoline, was run into a tank and weathered. The weathering consisted in allowing the lighter portions to volatilize spontaneously and escape into the open air until such time as boiling away of the liquid had practically ceased. Thus, the process involved a loss of 25 to 50 per cent., or even more. This loss was an absolute waste, not only of power and of cost of operating the engines and compressors but of the product itself.

The next step in the industry was to pass the waste gases (of which only the small quantity used for power had been utilized) from the single-stage compressor through a higher-stage compressor, thereby getting a second and more volatile product—a "wilder" liquid—which was run back into the first and mixed with the first or heavier condensate. This mixture was then again weathered to a safe degree, whereby it lost the greater part of the more volatile product that had been condensed in the second stage.

Recently the process had been improved another step, in that the first stage compressor product is run into one tank and handled as ordinary gasoline; the second-compressor product is run into a second tank and handled as a lighter gasoline, with which the heavy refinery naphthas can be enriched or enlivened.

The last-mentioned method of using the second-stage compressor product should receive wide recognition, and a market for the product should develop that would be no mean factor in the industry. Blending in the proportions of, say, 1 part of the product to 4 or 5 parts of the refinery naphthas makes these heavy naphthas more volatile and of greater value as fuel for automobiles; it also greatly increases their general usefulness. The proportions to be used in blending, however, must be determined more definitely by test.

The natural gas of this country frequently contains light products that do not condense in the second stage compressor, and for which it is practicable and necessary to install three, four, and even higher, stage compressors. These light products—true gases at ordinary temperatures and pressures—can be compressed and liquefied, but the liquid gases so obtained must be handled as gases and not as oils.

The mistake heretofore made in the natural gas gasoline industry, as some have recognized, has been the attempt to handle the light gaseous products as oils and not as gases. Until the manufacturers of this lightest third or fourth stage compressor product recognize its gaseous nature, the absolute necessity for insuring the safety of the public involves certain restrictions in its transportation, and not until it is realized that this extremely volatile liquid should be handled only in strong steel containers capable of withstanding high pressures will it be transported with safety.

Copies of this technical paper, No. 10, may be obtained by writing to the Director, Bureau of Mines, Washington, D. C.

來 來

Boiler Water

When the only available water for steam making contains sodium chloride or sodium carbonate or other mineral salts which interfere with steam making, the best way to overcome the difficulty is to condense the steam and use only distilled water in the boiler. This was done extensively in West Australia prior to the completion of the great Kalgoorlie pumping system, as salt water was the only kind available in that region. Caustic soda will loosen the scale.

Prevention of Smoke by Combustion

Addition of Fireclay Tubes in the Furnace to Retain Heat for Burning Distilled Gases

Perfect combustion is always smokeless.

With many fuels the initial step in the burning process is the distillation of volatile gases consisting of compounds of hydrogen and carbon. These gases form the flames seen when a wood, soft coal, or oil fire is burning briskly. Ordinary illuminating gas is

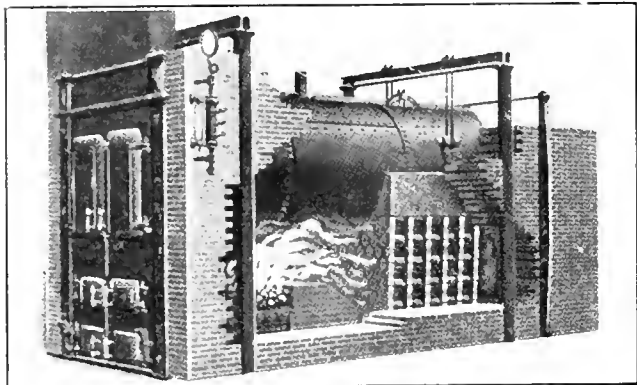

FIG. 1. FURNACE GAS CONSUMER ON RETURN TUBULAR BOILER

a mixture of such hydrocarbon gases, obtained by distilling coal or oil with certain proportions of hydrogen and carbon monoxide, neither of which would give light were it not for the presence of the heavier hydrocarbons.

There is no difficulty in burning these heavy hydrocarbons smokelessly, provided sufficient air is supplied and a sufficiently high temperature maintained. This may be readily demonstrated with an ordinary kerosene lamp. When burning freely with sufficient air, the flame is bright and clear, without a sign of smoke, but by gradually cutting off the supply of air to the lamp, or by increasing the amount of oil evaporated, a point will soon be reached when the flame will begin to smoke.

This simple experiment may, with advantage, be carried a step further. Remove the chimney of the lamp and introduce a cold body into the hitherto clear and bright flame. Immediately smoke will be formed, clouds of soot escaping into the atmosphere. Not only is a sufficient air supply necessary to complete smokeless combustion, but the combustion must be carried on at a high temperature. Cooling of the gases before combustion is completed results in smoke. The experiment may be varied again by mixing part of the air with the combustible before combustion begins, as by blowing into the flame with a tube ending in a fine orifice, or, as illustrated for gaseous fuels, by using the Bunsen burner commonly employed in connection with Welsbach mantles. This results in a more rapid and complete combustion, as is proved by the entire absence of luminous flame, it being well known that the luminosity of the ordinary gas flame is due solely to the incandescence of particles of carbon, that is, of soot.

These simple observations have a direct and important bearing upon boiler furnaces. In burning hard coal, the principal gas formed is carbon monoxide, which burns with a short, pale blue flame and without smoke. The burning of bituminous coal, however, always begins with the distillation of heavy hydrocarbon gases. This distillation of gases is so rapid that the amount of air coming through the fuel bed at the particular point where the new coal has been thrown on is rarely or never sufficient to effect complete combustion, and moreover the gases when first distilled from the fresh coal are not hot enough to burn freely, even were they mingled with sufficient air; thus incomplete combustion occurs, though sufficient air, or a great surplus, be coming through the fire.

If the freshly distilled gases can be mixed with hot gases and air from other parts of the grate, as is imperfectly accomplished

in so-called Dutch ovens or baffle-wall furnaces, fairly complete combustion may be effected. But once the distilled gases have come into contact with and have been cooled by the boiler surface, they will not burn afterward. The only way in which they can be burned is by mingling them with air at a sufficiently high temperature for ignition and combustion to take place.

The furnace-gas consumer recently devised consists of a series of refractory tubes set in the line of draft at or near the bridge wall, as shown in Fig. 1, in such a manner that the gases arising from primary combustion pass through them before reaching the boiler tubes. These tubes are supported in place by blocks of an appropriate shape and are placed end to end in five or six lengths. As the passages through the tubes have an aggregate area equal to or greater than the area through the boiler flues, the flow of the gas is not impeded.

One of the functions of these tubes is to store heat from the gases of combustion when the fire is quite hot, returning this heat subsequently to gases distilled from fresh coal and to air, thus creating the conditions essential for perfect combustion. The efficiency of the device in this respect may be judged from the fact that under a 100-horsepower boiler, approximately a total of 2 tons of tubes would be placed. As fireclay has a specific heat of about .23 and as it is heated quite or near to the actual combustion temperature, say 2,200° F., it can give off in cooling down to 1,500° F., which is still white hot, $(2,200 - 1,500) \times .23 \times 4,000 \text{ lb.} = 644,000$ British thermal units.

The heat-storage value of the tubes is forcibly illustrated by the fact, that while the fires are banked over night the steam gauge will work up to the blowing off point during the first 2 or 3 hours and after being reduced about 10 pounds, by cold feedwater, will retain about that pressure until morning. Instead of having 30 to 40 pounds of steam there is then 80 to 90 pounds. Immediately upon opening the drafts, the increased volume of air rushing through the tubes absorbs the stored heat and transfers it to the boilers. The hot tubes ignite the gases from fresh coal quickly, so that the gases are properly consumed, which further assists in raising steam more rapidly.

The tube stove also assists in maintaining a steady steam pressure, due to its "flywheel" action in storing heat, which serves to tide over irregularities in the operation of the boiler furnace, while the fires are being cleaned.

The heat stored under the 100-horsepower boiler cited above is enough to operate the boiler at full load for 12 minutes, and is amply sufficient to heat the distilled gases and the air for their combustion within the tubes during the short period after each

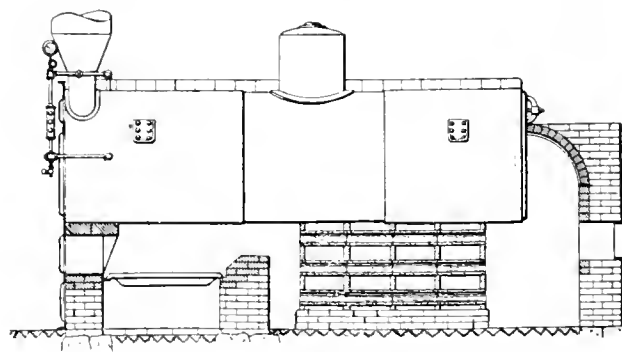

FIG. 2. SECTIONAL ELEVATION SHOWING GAS CONSUMER

firing when unburned gases are given off from the fuel bed. The gas consumer thus utilizes as fuel that part of the unburned gases which in ordinary furnace operation escapes unconsumed and unutilized up the stack.

The practical results are that the gases issuing from the stack are colorless for at least 95 per cent. of the time, only a slight volume of brown smoke issuing each time that soft coal is spread over the grate. In a large plant, where several boilers and grates are served by the same chimney, this small amount of smoke is hardly perceptible, due to its dilution by the clear gases from other boilers.

The more complete combustion of fuel sets free more heat, and the ability to burn the fuel with a smaller excess of air is even more advantageous. The amount of air theoretically required to burn a pound of fuel is about 12 pounds, but as boiler plants are ordinarily operated, the amount of air actually used varies from 18 pounds per pound of coal up to 30 or 40 pounds per pound of coal. If the gases be discharged into the chimney at 500° F., the efficiency of a boiler using coal of 14,500 British thermal units per pound will be 76 per cent. when 18 pounds of air are used per pound of fuel, and only 67 per cent. when 30 pounds of air are used per pound of fuel, 10 per cent. being allowed for loss through grates and by radiation in each case. By promoting better combustion with less air, better economy is obtained.

It is well known that the part of the boiler-heating surface exposed to direct radiation from the incandescent fuel bed transmits to the water a very large percentage of the total heat absorbed by the boiler. This fact is utilized in the construction of torpedo-boat boilers, where as much as possible of the heating surface is displayed over the fire, also in locomotive boilers, where the fire is entirely surrounded by heating surface. This is an excellent practice when using a smokeless fuel, such as anthracite, but when using bituminous coal, it results in the formation of dense clouds of black smoke and in the loss of a considerable portion of the available heat of the fuel, through the chilling of the gases, thereby preventing their perfect combustion.

But by installing the refractory tubes the full radiating value of the fuel bed can be utilized, without detriment to combustion, since the gases are consumed while passing through the banks of tubes. The latter for their part, also, are an efficient means of radiation, as the tubes are at all times at red or white heat and the part of the boiler lying above them is heated by radiation in just the same manner as that part of the surface lying above the grate is heated by radiation from the incandescent fuel.

The enormously greater efficiency of heat absorption by radiation, as against heat absorption by convection and conduction, may be illustrated by a few figures. The highest value that may be assumed for convection and conduction from the gases of combustion to the boiler heating surface is 5 or 6 British thermal units per square foot, per hour, per degree difference in temperature. Supposing the temperature of the gases is 2,000° F., and the temperature of the boiler is 366° F., while the coefficient of absorption is not to exceed 6 British thermal units per square foot per hour per degree, each square foot would absorb $(2,000 - 366) \times 6 = 9,804$ British thermal units per hour.

The transfer of heat by radiation depends somewhat on the nature of the radiating and receiving surfaces, but assuming dead black surfaces, Professor Kaulbars has found that the exchange of heat by radiation may be expressed by the following formula:

British thermal units radiated per square foot per hour = $\frac{T_1^4 - T_2^4}{601,000,000}$

Wherein T_1 is the absolute temperature (degrees F.+461) of the hot body and T_2 the absolute temperature of the cold body. Assuming the temperature of the tubes to be 2,000° F. and that of the boiler surface to be 366° F., as before, the exchange of heat per square foot per hour would be 61,000 British thermal units as against only 9,804 British thermal units by convection.

This material addition to the heat-absorbing capacity of the boiler naturally results in better boiler efficiency, since less heat remains to be absorbed from the gases by the boiler tubes. That is, adding the gas consumer is equivalent, as far as regards efficiency, to adding a large amount of boiler heating surface. The gases will escape to the chimney at a lower temperature, indicating higher efficiency of heat absorption. This saving is in addition to the higher efficiency due to better combustion.

The use of the consumer also improves the boiler by reason of the fact that it prevents the formation of soot, and its subsequent accumulation in the boiler tubes. Soot is a non-conductor of heat or blanket, and when allowed to accumulate on boiler-heating surfaces, seriously impairs the efficiency.

Obituary

WILLIAM ARTHUR LATHROP

William Arthur Lathrop, C. E., E. M., President of the Lehigh Coal and Navigation Co., died in Wilkes-Barre, Pa., on the morning of April 12, aged 58 years.

Mr. Lathrop was one of the most widely known and highly esteemed men connected with American coal mining, and was especially prominent in the anthracite regions of Pennsylvania.

Besides being the executive head of the Lehigh Coal and Navigation Co., he was also President of the Jed Coal and Coke Co. and of the Lathrop Coal Co., of West Virginia.

He was a man of most pleasing personality, invariably courteous and considerate in his bearing to all men, and withal a man of great force of character. In his death, thousands of men in all walks of life, from mine workers to men in executive positions, who either worked under him, or were associated with him, mourn the loss of a friend who held their affection and esteem in a remarkable degree.

He was the second son of the late Dr. Israel Lathrop, and was born at Springville, Susquehanna County, Pa. He was



WILLIAM ARTHUR LATHROP

descended on both paternal and maternal sides from Colonial and Revolutionary ancestry.

His early education was acquired at Springville, after which he entered Lehigh University from which he graduated in 1875 with the degree of Civil Engineer. He afterwards took a course in mining and was awarded the degree of Engineer of Mines from the same institution, of which he was an honored and efficient trustee at the time of his death. Immediately after leaving Lehigh University he accepted a position as assistant engineer on the Lehigh Valley Railroad, later becoming connected with Major Irving A. Stearns, a life-long friend, who at the time was engaged in a general mining engineering practice at Wilkes-Barre. He remained with Major Stearns but a short time, when he returned to the service of the Lehigh Valley Railroad Co. In the early eighties he went to Virginia and opened and managed the Pocahontas mine, which was the pioneer operation in the great Flat Top field. In 1884 he accepted the position of superintendent of the Lehigh Valley Coal Co.'s bituminous operations in the Snow Shoe region of Pennsylvania. In 1888, on the death of Frederick Mercur, he became General Superintendent of all the Lehigh Valley Coal Co.'s mines, both anthracite and bituminous, with headquarters at

Wilkes-Barre. Later, he was made General Manager of the company.

In May, 1901, he resigned as General Manager of the Lehigh Valley Coal Co. to take the Presidency of the Webster Coal and Coke Co. which later was merged into the Pennsylvania Coal and Coke Co., of which he became President.

In December, 1906, he resigned the presidency of the Pennsylvania Coal and Coke Co. to become General Manager of the Lehigh Coal and Navigation Co., and in the following February he was elected president of that corporation, with headquarters in Philadelphia. Besides his connection with, and interests in the mining companies already mentioned, he was prominently identified with other business enterprises, prominent among which were the Fourth Street National Bank of Philadelphia, and the Peoples Bank of Wilkes-Barre, of both of which he was a director.

As a collegian he became a member of Psi Chapter of the Chi Phi Fraternity. He was a member of the American Institute of Mining Engineers, of the Pennsylvania Society Sons of the Revolution, of the University Club of Philadelphia, the Westmoreland Club of Wilkes-Barre, the Wyoming Valley Historical and Geological Society, and other professional, historical, and social organizations. In religious belief, he was an adherent to the doctrines of the Protestant Episcopal Church.

Mr. Lathrop was married on March 21, 1881, to Miss Harriet E. Williams, of New York City, who with a daughter, Miss Helen, survives him.

His funeral took place from his late home in Dorrancetown, a suburb of Wilkes-Barre, on April 15. The character and number of those attending to pay a last tribute of respect was remarkably great. His remains were interred in Forty-Fort Cemetery.

來 來

Book Review

APPLIED METHODS OF SCIENTIFIC MANAGEMENT, by Frederic A. Parkhurst, M. E., Organizing Engineer. This book has 325 Svo pages, 48 figures, and nine plates. It is an amplification of the author's article, "Applied Methods of Scientific Management," which appeared in *Industrial Engineering* during the last 9 months of the year 1911. It has seemed advisable to publish the serial in book form because of its success. An appendix contains much new matter which was not included in the original publication for want of space. The instructions and forms show substantially the medium employed to incorporate the principles of the science of management into an efficient organization suitable for a plant under the specific conditions illustrated. Theories and generalities have been avoided, and the subject has been treated from the practical point of view, intensified by many years of experience along these lines. The book is published by John Wiley & Sons, New York City, and by Chapman & Hall, London.

OBSERVATIONS ON THE WEST OF ENGLAND MINING REGION, by J. H. Collins, F. G. S. This book is an account of the mineral deposits and economic geology of the west of England, and forms Volume XIV of the Transactions of the Royal Geological Society of Cornwall, of which Mr. Collins is president. It is in two parts, contains 683 pages, with index, and 18 page plates. The compilation of this work has been a task and the book will stand for a few years as authority on the geology of the country it covers. Aside from its usefulness for instruction and reference, it is good reading. The book has been printed for the author, whose address is Crinley, Par Station, Cornwall, England. The book is dedicated to the Earl and Prince of Wales and Duke of Cornwall, and among the British subscribers well known in this country, are Messrs. Philipps, W. S. Bayley, B. B. Lawrence, James Osborn, J. E. Spurr, H. M. Stalder.

WEST VIRGINIA GEOLOGICAL SURVEY. Detailed county report on Jackson, Lincoln, and Putnam counties, 387 pages plus XIV, with 36 plates and illustrations, and a case of three maps (topographic, geologic, and soil) of the entire area in single sheets, being

the largest maps yet published by the State Survey. In addition to the detailed study and description of all the rocks, minerals, soils, and streams found within the area, the geologic map gives the structural contours on the Pittsburg coal horizon, as well as the approximate area underlain by that bed. The topographic map shows by contours and figures the elevation of the surfaces, and in addition gives all streams, roads, railways, towns, mines, etc., in their correct locations. The soil map and report made by the United States Department of Agriculture's Bureau of Soils should prove of especial value to the agricultural and horticultural interests. Price, with case of maps, delivery charges paid by the Survey, \$2. Extra copies of topographic or geologic map, 50 cents each. Send remittance to the West Virginia Geologic Survey, Morgantown, W. Va., Lock Box No. 448.

BUSINESS CORRESPONDENCE LIBRARY. The System Co., Chicago, Ill., three volumes, 672 pages, \$9. Here in three volumes are packed the success secrets back of the letters that are actually winning the biggest results today. Two years of investigation by a staff of experts were spent collecting the letters of firms and individuals; investigating the actual results; analyzing the comparisons of costs and profit; studying the difference in results obtained by differences in arrangement, wording, enclosures, etc. Every striking idea found in use by mail-order house, wholesaler, manufacturer, retailer, real estate or insurance man, bank, collector, individual salesman or complaint clerk, was followed out and its returns studied. This mass of information was then charted and developed into one complete, yet concise library so clear and simple that from it any busy man can pick out for any sort of proposition, an idea or suggestion that he can know in advance to be successful; or can turn to for original inspiration, a work that will show any man how to write or dictate the kind of letter that arouses attention and carries its point.

BUREAU OF MINES, Washington, D. C., Technical Paper No. 6, The Rate of Burning of Fuse as Influenced by Temperature and Pressure, by Walter O. Snelling and Williard C. Cope; Technical Paper No. 8, Methods of Analyzing Coal and Coke, by Frederic M. Stanton and Arno C. Fieldner; Bulletin No. 36, Alaskan Coal Problems, by Walter L. Fisher.

UNITED STATES DEPARTMENT OF AGRICULTURE, Washington, D. C. Circular No. 97, Coke-Oven Tars of the United States, by Prevost Hubbard.

DEPARTMENT OF MINES, Mines Branch, Eugene Haanel, Ph. D., Director, Ottawa, Canada. Preliminary Report on the Mineral Production of Canada During the Calendar Year 1911, by John McLeish, B. A.

DEPARTMENT OF COLONIZATION, MINES AND FISHERIES, Mines Branch, Quebec, Canada. Preliminary Statement on the Mineral Production of the Province of Quebec, During the Calendar Year 1911.

DEPARTMENT OF LANDS, FORESTS, AND MINES, Bureau of Mines, Toronto, Ontario, Canada. Bulletin No. 9, Report on the Mining Accidents in Ontario in 1911, by E. T. Corkill.

UNIVERSITY OF ILLINOIS, Urbana, Ill. Bulletin No. 53, Inductance of Coils, by Morgan Brooks and H. M. Turner; Bulletin No. 54, Mechanical Stresses in Transmission Lines, by A. Guell.

BUREAU OF LABOR STATISTICS, David Ross, Secretary, Springfield, Ill. Bulletin of Industrial Opportunities.

VIRGINIA GEOLOGICAL SURVEY, University of Virginia, Charlottesville, Va. Bulletin No. 4, The Physiography and Geology of the Coastal Plain Province of Virginia, by William Bullock Clark and Benjamin Leroy Miller.

NORTH CAROLINA GEOLOGICAL AND ECONOMIC SURVEY, Joseph Hyde Pratt, State Geologist, Chapel Hill, N. C. Bulletin No. 20, Waterpowers of North Carolina; Bulletin No. 23, Forest Conditions in Western North Carolina, by J. S. Holmes; Economic Paper No. 23, The Mining Industry in North Carolina During the years 1908, 1909, and 1910, by Joseph Hyde Pratt and Miss H. M. Berry.

GEOLOGICAL SURVEY OF TENNESSEE, George H. Ashley, State Geologist, Nashville, Tenn., Volume 2, No. 3, The Resources of Tennessee.

Mine Explosion at McCurtain, Okla.

Conditions in the Mine—Probable Cause of Explosion—Description of the Rescue Work

By A. A. Steel*

On Wednesday, March 20, at 9:30 A. M., a severe explosion, which killed 73 miners, occurred in mine No. 2 of the San Bois Coal Co., at Chant-McCurtain, Oklahoma, 37 miles west of Fort Smith, Ark. The mine is owned jointly by the coal company and the Fort Smith & Western Railway, and is the chief source of fuel for that railway.

The coal is a remarkably soft and fragile semibituminous variety which makes good coke. The dust is extremely explosive and the mine has blown up seven times in 8 years. The second explosion in the early part of 1906 occurred in the morning while only a single fire boss was in the mine. It was severe and is supposed to have been a dust explosion which was started and aided by gas. All the others, except the recent one, were dust explosions resulting from heavy blasting and killed only one or two shot firers each time. The first and second explosions and the one in 1909 were severe and wrecked the mine badly. Late in December, 1909, a slight explosion occurred. The mine was cleaned up and mining was resumed on January 3, 1910. That night there was a very severe explosion, caused by the firing of the old and damp black-powder shots left from the week before and intensified by the dry condition of the mine which had not been sprinkled since the last explosion. Mine No. 1 adjoining No. 2, and upon a similar but possibly a different seam of coal, has had but one explosion, which occurred in 1906. There has been no explosion at No. 3.

On account of the dangerous nature of the coal dust, Supt. A. H. Brown had all entries fitted with water pipes, and from

*Professor of Mining, University of Arkansas.

one to three men employed in washing down the sides and roof of all working places with a hose. The explosion of 1909 was caused by dynamite, which is considered safer than black powder, and in the winter of 1910-11, when there was no explosion, it was used entirely. For some months Monobel permissible explosive has been used exclusively. This is let down into the mine and unloaded at the partings after the fire boss goes out, but before the men go down into the mine. It is later taken by the drivers to the miners' rooms. A mercury barometer is kept at the office and at the home of the superintendent and readings are taken daily. Morning and evening records of the United States Weather Bureau at Fort Smith show that the barometer had fallen steadily from 29.658 inches at 7:00 A. M., March 18, 1912, to 29.363 inches, at 7:00 A. M., March 20, and by evening it read 29.236 inches. It then rose. It had been high since March 15. The mine is also inspected by the state inspector more frequently than required by law.

The general layout of the mine is indicated in Fig. 1. The main slope starts down the axis of an anticline pitching about 6 degrees or 7 degrees to the west. The entries at intervals of 300 feet along the slope are driven at an approximate water grade back along the flanks of the anticline until the dip becomes quite steep. There are many faults in the mine, both strips of crushed coal and faults in the geologic sense. At the ninth entries, the anticline ceases. To the north, the coal seam is full of hills and hollows with no uniform dip and therefore the entries were driven irregularly among the hills of coal.

To the south the coal dipped quite regularly away from the slope. Therefore a new slope was turned off to this side. On account of the distance from the tippie a relay hoist was placed on the prairie about 375 feet above to draw the coal up the "Little Slope" to the "Big Parting" at the angle. From this little slope, 10, 11, 12, and 13 cross-entries had been turned north and south. From the lower entries of a pair, dip rooms were occasionally turned, but most of the coal was obtained from

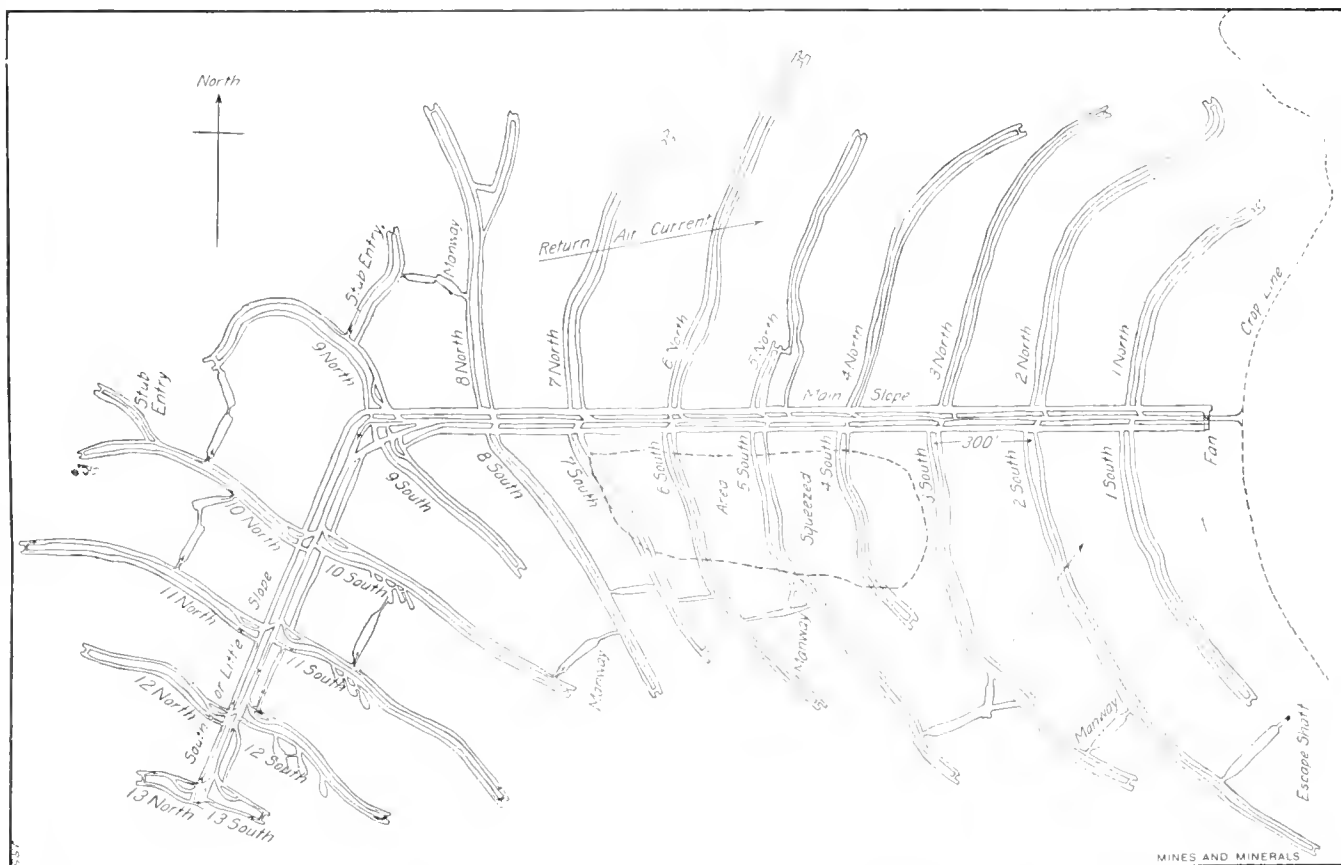

FIG. 1. OUTLINE MAP OF MINE NO. 2, SAN BOIS COAL CO.

rooms some 250 feet long, 24 to 30 feet wide, driven to the rise at from 36- to 46-foot centers.

The entries south of the main slope from about the 3d to the 7th had squeezed shut some time ago. Some work was in progress at the time of the explosion in the ends of entries 6 and 7, which were reached from the 8th or 9th entry below. There is a continuous passage behind the squeezed area to an escape-way some 1,200 or 1,500 feet south of the entrance to the main slope. This had been installed shortly after the squeeze at the order of one of the state mine inspectors. It was clearly marked by numerous large sign boards.

In most parts of the mine, there was 7 feet of coal with a middle band of rather soft dirt 18 to 24 inches thick. The entries are driven wide to give space for gobbing this dirt. The entries are short and mules are used for bringing the coal to the slope. In the rooms, the coal is all shot off the solid, but in the entry a shearing is made to the depth of about half the 9- or 10-foot shots used. As a result of the use of dynamite, and the state law compelling payment upon a mine-run basis, over 50 per cent. of the coal passes through the 1 $\frac{1}{4}$ -inch screens used in preparing lump coal. This mine has always given off a good deal of gas, which has been especially troublesome in the 11th entry that was being extended into new territory remote from older workings. Quite a little gas was given off from the faults.

Most of the mine water is collected between the 12th and 13th entries in a sump off the little slope. It is raised to the surface through a drill hole by a pump driven by compressed air. The compressed air is let down through another drill hole.

From the main pump a 1 $\frac{1}{4}$ -inch pipe supplies compressed air to the sinking pump located in the south slope air-course, as shown in Fig. 2. The explosion did not stop the pumps and they were kept running constantly in the hope that the exhaust air might save some of the miners as it did.

The output of the mine is 450 tons per day. At the time of the explosion, the underground crew consisted of the pit boss, two fire bosses, one boss driver, eleven drivers, two rope riders, one door boy, one car spragger at the big parting, one brattice man putting in stoppings, three timbermen, three rock men, three trackmen, one man in charge of sprinkling assisted by the two pumpmen, and some 70 pick miners. At night, there were five miners, one shot firer, and one of the pumpmen.

Ventilation was maintained by a substantial 12-foot Capell fan running at about 135 revolutions per minute and exhausting air through an explosion drift from the south slope return—built to one side of the main entry as a precaution against explosions. The intake air went down the main slope to the 12th south bottom entry. At this point one split was coursed up the slope air-course, through the workings upon the 11th south bottom and top entries, and the stub entries turned up from them. It goes back to about room No. 6 of the top entry. From this room a long manway carries the air through the intervening entries to the workings of the 6th and 7th entries and on behind the squeeze to the fan. The other split is coursed through the 12th and 13th south entries over to the 13th, 12th, and 11th north entries and cut through the north manway and old workings to the overcast across the main slope. All stoppings were made of two thicknesses of inch boards with tarred canvas between. The chinks were stopped with gypsum and wood fiber plaster and kept as tight as possible. Unfortunately the law requires breakthroughs to be driven "not more than 30 feet apart if gas is present," and there must have been a good deal of leakage of air through the stoppings and doors above the point of division, some 5,000 feet down the slope. The explosion did not derange the ventilation of the mine above the 11th entries, except for a light puff of smoke forced out of the main slope. At one time, Mr. Hanratty, the former state mine inspector, required the installation of a complete system of overcasts and separate splits of air-current. On account of the squeeze and the irregular lower workings this was abandoned.

The records of the fire bosses' book show that on the morning of March 20, Fire Boss Kokosky had reported the north side of the mine free from gas, but that Frank Crook had found gas in the face of the 11th south top entry, in room 25 off of this entry, and in room 19 of the 12th south top entry. On March 19, gas was also reported in the face of the 11th south entry and in room 19 of the 12th entry. At the face of the 11th south entry was found the body of Fire Boss Frank Crook. Further back in the entry were the bodies of a number of men with their coats on, who were evidently waiting for the fire boss to remove the gas. Two of these men were dangerously close to the gas, as shown in Fig. 2. One man was at the last breakthrough which was supposed to carry fresh air while the other was near the next breakthrough almost in the direct course of the outgoing air. The fire boss worked with a safety lamp but it is assumed that the others had their open lamps burning. The fact that they had their coats on indicates that they were not assisting the fire boss. Other miners nearer the fan, the driver and two timbermen found in the manway leading to the 10th entry would provide ample means of igniting any body of gas driven out sufficiently fast to be explosive. Individuals have been burned in this mine upon previous occasions by fire bosses sweeping bodies of gas into their lights but heretofore the gas was so concentrated that it merely burned the miner more or less seriously and produced little explosive effect. The violence of this explosion lends weight to the idea that the gas was ignited some distance beyond the workings in which it was first found. It may be that the miners in several rooms were kept waiting on the entry in order that the gas might be swept through the breakthroughs between the empty rooms. In this case the first lights it would reach would be those of the miners found in room 19, only six rooms back from the standing gas. By this time it would be well mixed with air. It seems likely that the fire boss underestimated the quantity of standing gas or did not realize that the incoming air had already passed through gassy workings and contained gas even though it did not register in a safety lamp. It is also possible that the five or six men with their coats on got impatient to go to work after waiting an hour and a half and urged the fire boss to sweep the gas out in a hurry. There still remains as alternative possibilities the chance that the fire boss had a defective safety lamp or carelessly tested the workings for gas after arranging the brattices, or that some one of the men went over the dead line.

However it was touched off, and it is certain the explosion originated in this entry, because as stated, it contained gas enough to show in the lamp in at least two places. The fire boss was working in one of these gassy places; the men still had their coats on waiting for the gas to be removed and some were sitting down. All the men were badly burned and suffered little if any violence. The hot blast threw out the door to the slope and broke the stoppings in the outer part of this entry.

Such accidents will happen as long as the law allows men to use their judgment as to whether it is safe or not for miners with open lights to work on the return side of bodies of gas. The Oklahoma law simply requires the fire boss to dead line all places containing any gas and to keep all the men out of the mine if it contains dangerous quantities of gas. This has been carried out so carefully in the past that some of the miners, who had been inside a dead line without causing an explosion, were disposed to consider the dead line of the fire boss as of little importance.

The only departures from ordinary practice common in Arkansas and Oklahoma were that more precautions were taken than were required by the imperfect mine law, so the general management of the mine cannot be especially criticized. Because of fear of the dangerous dust, the ventilating current was purposely kept as low as safe in order to prevent the drying out of the dust. The writer knows that it was frequently measured some years ago by the inspector and there is

every reason to believe that at the time of the explosion the air-current slightly exceeded the 30,000 cubic feet per minute which is required under the state law for the number of employes in the mine.

The force of the explosion seems to have spread across the slope to the 11th entry. This had been finished by working up to a fault and the sprinkling pipe was taken out. It was presumably rather dry and was on the return side of all the workings on the other split. As a result, this entry was the most affected of all the workings. Mr. C. S. Stevenson of the Bureau of Mines told the writer that there was coked dust all along the entry. There was much coke in the dead end of a room 40 feet beyond the cross-cut indicating a good deal of gas. From the 11th north entry the explosion spread through the manway to the 12th north entry. All the men in this entry were burned to death, the stoppings were blown out, and the standing trip at the parting was blown to the main slope and piled up to a slight extent. Some eight of the rooms near the end are badly caved. The pit boss and all the men working in that entry were killed so no certain information can ever be obtained. The first search party entering it found that the inner third of it had filled with apparently pure gas within some 30 hours after the ventilation was cut off.

The explosion spread an unknown distance into the old workings above the 11th north entry. In the 11th south entry where it seems to have originated, there is one heavy fall on the roadway. The men in the manway above the 11th south entry were terribly burned but the miners working in the 6th and 7th entries, some distance above, report that they did not know there had been a serious explosion until they were driven out by the gases. The workings between these places must have been wet and nearly free from gas.

Practically no damage was done in the 12th south, the 13th south, and the 13th north entries, which were at the intake of the second split of air. The general result of the explosion is therefore about what would be expected of a gas explosion reinforced by dust in the 11th north entry and possibly the 12th north entry. It was generally reported that a small fire was left in the 11th south entry but quickly extinguished by relief parties. The volume of afterdamp was much less than that which follows the

dust explosions common in the Southwest, and the injury to the mine was negligible compared with that done by the explosion of 1909. It was suggested that the day men getting ready to take up track might have gone into gas in the 12th north entry which was not examined by the fire boss. Mr. Stevenson and his men equipped with oxygen apparatus thoroughly explored this entry, and found much gas but no bodies, so this idea must be abandoned for the present.

It was also suggested that since Engineer W. D. Roper and two assistants had just gone into the mine to finish the survey of the new workings they may have blundered into gas in old workings. Their bodies and instruments were found in the lower portion of the main slope and the 13th entry where the air was nearly free from gas. The condition of Mr. Roper's maps and notebooks as well as his reputation in the camp prove that he was a very competent and careful young man so there is little foundation for this rumor. The newspapers suggested this, so it may be well to state that, before coming to the mine, Mr. Roper had been Professor of Physics at the Virginia Military Institute. It is therefore certain that he understood mine gases too well to be likely to make such a mistake.

The explosion took place at 9:30 A. M., an hour and a half after the day crew had entered the mine. The mine surveyor and two assistants had gone down the mine but a short time before, and the pit boss and both fire bosses happened to be in it at the time. The superintendent of the mine, A. H. Brown, with Mr. Bushnell were at mine No. 1 about a mile away. There was but little report, and the cloud of dust and smoke thrown from the mine was only sufficient to attract the attention of the men at mine No. 1. Brown and Bushnell hurried to the mine and expected to see the miners come out. One miner who had been walking up the slope not far from its mouth, jumped to a refuge hole at the side to allow the blast to pass. He was just able to stagger out of the mine but soon recovered and later did good work with a helmet.

When no more men came out, Mr. Brown and others followed the fresh air down to the 11th entries at which point the air-current was short-circuited off the slope. Here the slope was choked with hot impassable gases and Brown hurried out for assistance. He was met by a number of miners from mine

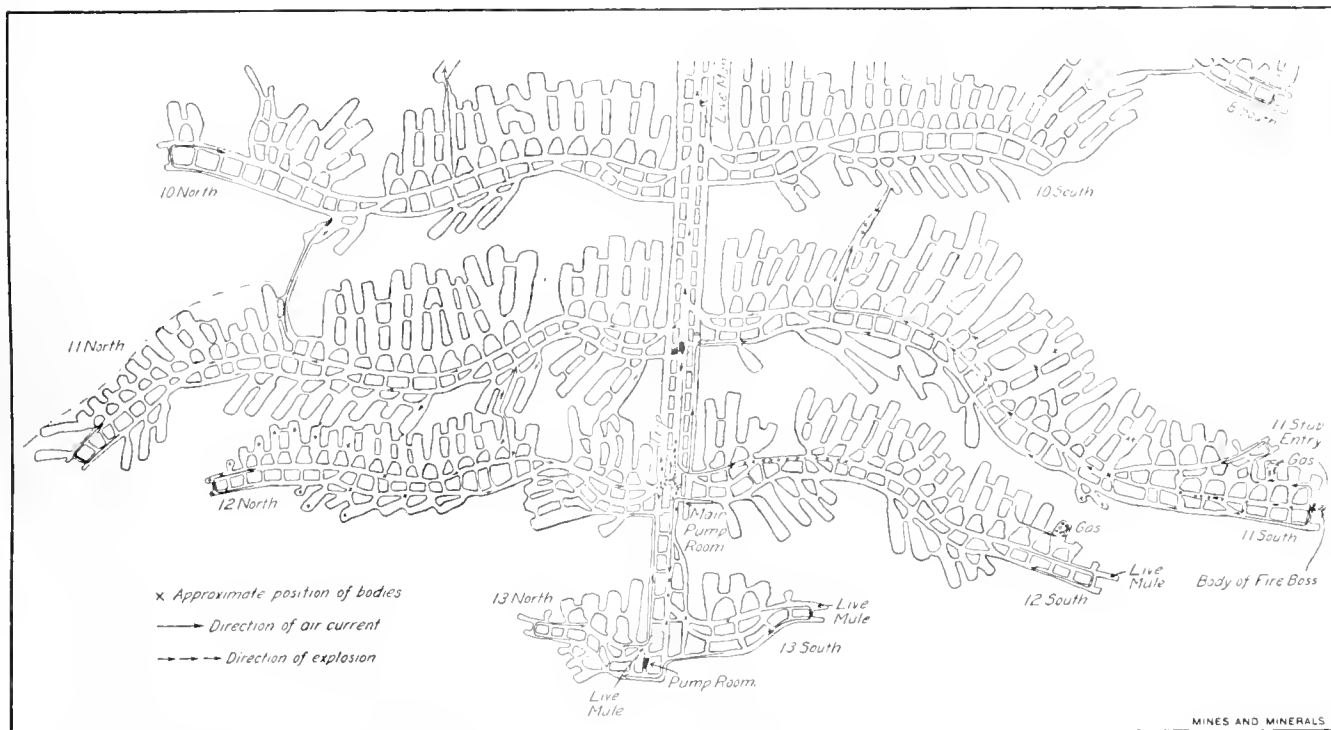

FIG. 2. MAP OF LOWER PORTION OF MINE No. 2, SAN BOIS COAL CO.

No. 1 with open lights. He directed them to begin work at once. While the first investigation was being made in the main slope a party of 10 miners came out of the distant south escapeway. They had been working in the 6th and 7th south entries and were driven out by the smoke. They waited to get their coats and dinner pails and before getting out four of them were nearly overcome by gas and had to be assisted by their companions. But all the men in this part of the mine, including the driver, escaped. Fortunately the main return air-current leaves the manway and passes through the old workings to the fan. As a result these miners soon got into the leakage current of fresh air coming down the escapeway. They were familiar with the mine and took an active part in the work of recovering the bodies.

As soon as Mr. Bushnell learned that the explosion was really disastrous, he wired Fort Smith for a special train carrying nurses and doctors and notified the Government Rescue Station at McAlester, 40 miles away.

From this time the work of rescue was quite disorganized until the arrival of Mr. Stevenson, of the Bureau of Mines, on Friday afternoon. As soon as Mr. Brown found the lower working completely clogged with hot gases, the realization of the fate of his pit boss and all the men seems to have quite unnerved him. He was thereafter unable to effectively direct the work. His mental condition became steadily worse until he was taken to a hospital in Fort Smith on Saturday. He was once severely burned in an explosion and in 1908 he directed the work of recovering the shot firers and restoring the mine with the greatest courage, energy, and ability. The writer spent a good deal of time studying this former explosion and speaks of Mr. Brown's record from his own knowledge.

Some blame can be attached to the headquarters force for not arranging for the early relief of Mr. Brown. The high officials of the company are railroad men and did not realize the situation. The most experienced pit boss, William Farrimon, was lost in the explosion, but George McAlpine, pit boss at mine No. 1, immediately came over to mine No. 2 and looked after affairs as best he could day and night until absolutely worn out. He was hampered by lack of authority to make requisitions for supplies, to arrange for some man to take his own station at night, or to place other persons in charge of general affairs.

The greater number of men familiar with the mine were lost in it or else needed to take care of their kindred as soon as the bodies were recovered. Those superintendents, pit bosses, and miners working in the other mines of McCurtain or surrounding camps, who had ever worked in this mine, hastened to offer their services. In this way competent leaders for the rescuing parties were secured and the work was soon under way in the 3-hour shifts under the general command of Mr. Brown who was assisted as much as possible by Mr. McAlpine and his friends. There was constant danger of conflicting orders and the mine contained so much gas that only the caution of all men underground prevented a disastrous after explosion.

Mr. Bushnell's message for aid was received about 10:35 A. M., by W. T. Burgess, foreman in charge of the United States Bureau of Mines Rescue Station at McAlester, only 10 minutes before the departure of the Katy flyer. The fast train was held 17 minutes. During this time, Mr. Burgess collected what apparatus he could and secured a dray to take it to the station. With Mr. Burgess was Lee Hubbard, a young man who had just begun his training as a helmet man. At Crowder City, Mr. Bushnell had waiting a special train to carry the party to the mine, where they arrived about 1:45 P. M. the day of the accident. With the party also came P. R. Allen, a mine superintendent of McAlester, and Peter Hanraty.

Mr. Hanraty is a man of much force and ability and made a fine record as former state mine inspector. As it was, he could only offer his services, but had no authority to take charge of affairs. The writer is not personally acquainted with Mr.

Hanraty, but is of the opinion that he would have soon realized the situation and taken general charge if he had had authority.

The present state mine inspector, Ed Boyle, of McAlester, and the inspector for the district, Frank Haley, of Henryetta, were quite late in arriving and Mr. Boyle was not persuaded to take even nominal charge of the work until Saturday morning. Mr. Clark, the mine inspector of another district arrived early, and did good work as a volunteer with the earlier rescue parties but he was without authority. Unfortunately, the mine inspectors of Oklahoma are elected by direct vote of the people and the relations between Mr. Boyle and Mr. Clark were so strained that Mr. Clark could do little actual work after the arrival of his superior. Both Mr. Boyle and Mr. Haley worked hard in the mine after their arrival, but they should have taken an executive instead of subordinate position.

The Rock Springs, Wyo., Mine Safety Car No. 4, of the United States Bureau of Mines was stationed at Ottumwa, Iowa, at the time of the explosion. At 6:50 P. M., on Wednesday, C. S. Stevenson, engineer in charge of this car, received word to proceed to McCurtain but on account of the distance and the many train delays and connections, the car did not arrive at McCurtain until nearly 5 P. M., Friday. After the first reconnaissance in the mine, Mr. Stevenson saw that the greatest need was a responsible chief of the rescue work. He requested Mr. Boyle to assume this responsibility and very tactfully suggested the additional precautions needed, but by the authority of Mr. Boyle, Mr. McAlpine continued to actually carry out the work. Thereafter all work proceeded carefully and systematically until the writer left the camp.

The first party of miners going down the mine found the body of a trapper boy on the big parting at the head of the little slope. He was lying in a shallow pool of water and had evidently been drowned after having been stunned. A little lower down somewhere between the 9th and 11th entries they found the rope rider of the little slope. He was unconscious but still living, and was revived at the surface. One or two other bodies were found above the wrecked trip at the 12th entry, but the work of further exploration was delayed by lack of a sufficient number of safety lamps. Those at the mine had not been kept in repair and few were ready for use.

Mr. Burgess brought with him nine Wolf lamps which were immediately turned over to the rescuing parties. He also had four helmets and a sufficient supply of electric lamps and batteries for the helmet men, but had no pulmotor respiratory apparatus. He was criticized for not bringing more electric lights, but this shortage probably saved the lives of some miners, who under the disorganized conditions of the work might have rushed into deadly gases if they had been provided with lights that would permit this. The shortage of time is ample excuse for Mr. Burgess.

Upon the arrival of the helmets at 1:45 P. M., there was a great delay on account of the lack of trained helmet men. A few of the first volunteers had been drinking and time was necessarily lost in selecting men and giving them the vital preliminary instructions. It is said that there was an undue delay in charging the apparatus with oxygen, but it seems that only a few necessary adjustments needed to be made.

At about 4 P. M., the first helmet party was let down the mine. Many miners were at work in the mine without definite supervision and Mr. Burgess deemed it prudent to proceed cautiously with his untrained crew and to return to fresh air at short intervals. The 11th south entry was explored early by the helmet men but all the men in this part of the mine had been burned to death and no lives were saved.

Most of the men of the 12th south entry were found in a string near the parting with their coats and dinner pails. It is obvious that they did not know that the explosion had been very serious and were on their way out of the mine when suffocated by the incoming afterdamp. The body of one suffocated man

was found in the slope above the cars. The rescuers reported that these cars were above the 12th south entry as well as above the 12th north, but the map of the mine makes this seem unlikely. It is probable that the man above the cars had been in a sheltered spot near the mouth of the 12th south entry and had not climbed over the trip as the miners said. All these men had apparently been dead some time when reached.

Mr. Burgess did not take his men past the piled up cars at the mouth of the 12th north entry. This seems to have been unfortunate because from the beginning it was hoped that men might be saved in the pump rooms by the exhaust of the compressed air, and the helmet men should have made every effort to get there. As it was, the miners carried the air down the slope as rapidly as possible. As soon as they had reached the vicinity of the main pump, they heard rappings upon the air pipe and hurried down toward the sinking pump. They were met by a small party of survivors carrying the Davy lamp of the fire boss. It seems that men in the little pump room had noticed that the air was cooling off and had sent out a reconnoitering party. It was presumably for signals between these parties that they rapped on the pipe.

Reports as to the number of men who had lived in the pump room differ. There were either 13 or 14, but more likely the smaller number. The writer talked with a number of these men and their story is about as follows: The 13th north entries are short and all the men in them, including the driver together with the fire boss for the south side of the mine, assembled near the parting on the way out. They had all been knocked down by the concussion, but none were especially injured and one or two did not lose their lights. In the slope they were joined by some men from the 13th south entry. A short distance below the 12th entries they were met by the cloud of hot afterdamp coming down the slope and all went back except Joe Gusio. As soon as this man's brother, Shy Gusio, saw what a good refuge the pump room would be, went back and urged his brother to return. but Joe persisted in his effort to get through the gas. Shy returned to the pump for air and made one more effort to get his brother. On this trip he, possibly assisted by the others, brought back a weakened but still living man. This man revived sufficiently to tell the others that he had heard some one groaning in the slope. The heroic miners in the room went out after this man who proved to be the engineer's young assistant who had just undertaken to do his first day's work in the mine. He revived only long enough to thank his friends. He had been in the slope with the engineer and was probably severely injured by the blast.

The upper end of the pump room was closed by a wooden stopping with a small opening in it. This opening was for the convenience of the pump men, and was covered by canvas. While some of the miners were bringing in the disabled men, others secured brattice cloth and closed the lower side of the pump room as rapidly as possible. The destruction of the stoppings in the 11th entries had short-circuited most of the air-current and the gases probably spread quite slowly down the slope. As soon as the barricade was complete some of the miners took off the steam chest of the air pump and so they got the full stream of compressed air from 1¼-inch pipe some 200 feet long. The main pump was supplied by a 2½- or 3-inch pipe from mine No. 1.

Some 2 hours after the explosion, the pump room became very hot and the common pit lamp would not burn. During the entire intervals, the acetylene lamp of one of the miners continued to burn. Some hours after he was brought to the pump room, the miner who was carried in by Mr. Gusio died. Some of the survivors lost consciousness or as they say went to sleep. All were dizzy. Later the place cooled off and the sleeping men awoke. The room was small and the floor covered with water. Toward morning, one of the men became very thirsty. He did not wish to drink the water in which the dead miner was lying

and his companions passed him a gallon can of the miner's lamp oil to drink. This is a very impure lard oil and it was probably fortunate for his stomach that the can was dropped and the oil spilled.

The men were rescued early in the morning of Thursday after they had been in the pump room for about 20 hours. Nine of them were able to walk out without assistance. The other four had to be helped out. On Saturday, four of the miners were still sick in bed.

The mule of the 13th north entry is still alive and apparently well. He was found standing on the parting just outside the pump room. This indicates that the mules can stand more afterdamp than moving men. The mule of the 13th entry was further in and unhurt. The mule of the 12th south entry was standing with an empty car in the face of the entry. There seems to be no doubt that the men found dead near the mouth of the 12th south entry on their way out would have been saved if they had retreated to the end of the entry, barricaded themselves against the afterdamp and put out their lights as protection from fire-damp given off by the new workings. The men in the 13th south entry had the best chance in the little pump room.

The main pump was in an open passageway and could not have been barricaded. The rescuers found one man here who had died with his face under the exhaust. It is of course possible that he had been brought there in an exhausted condition by companions who had placed his head in this position and lost their own lives endeavoring to escape. The pumpman who was a physical giant was found suffocated some 100 yards up the slope.

The rescuers claim that they found two living men below the wrecked trip, who died while their arms were being worked in an effort to revive them. It might have been that these men and the one above the trip remained at the big pump until most of the afterdamp had passed. Otherwise and more likely the rescuers were mistaken in thinking that they were alive because it is known that the men in the pump room were nearly overcome. Still a pulmotor would have been very useful.

The men in the 11th south and 12th north entries had evidently been immediately killed. Pit-Boss William Farrimon had been thrown up the slope air-course from the 12th north parting and had his neck broken. The engineer's transit was found on the slope opposite the 12th south parting, which was below the obstruction. His assistants were not far away and had probably been injured. Mr. Roper's body is said to have been found in the outer part of the 13th north entry. All the bodies in the 12th south and 13th south entries and some of those in the main slope were those of men who had been suffocated while attempting to escape.

No systematic record of the recovery of the bodies was kept. On Saturday morning the entire mine had been explored and County Judge A. L. Beckett and the miners' check-weighman made a careful poll of the camp. This showed that at that time 73 miners were missing and that 68 bodies had been recovered. Since then 3 more have been recovered.

The first bodies were recovered on the slope above the wrecked trip. Those below the trip in the slope, the 12th and 13th south entries, and the 12th north parting, were soon taken out. Early in the work, a few bodies were taken from the inner part and extreme end of the 11th south entry. Later work was concentrated upon moving out the great accumulation of gas in the 12th north entry and recovering the exposed bodies in it. Finally, on Friday, 12 more bodies were taken from the 11th south entry. Many of the dead were so badly burned that they were identified only by the numbered metal checks found in their pockets or by their position in the mine and the tools found with them. Up till Saturday no bodies it is understood were found that had not been positively identified.

By Saturday noon, the mine had been thoroughly searched by Mr. Stevenson and his men equipped with the Westphalia

apparatus. They found no more bodies but much firedamp. As a result, it was decided to completely restore the ventilation and proceed to systematically clean up the mine and recover the buried bodies. This will take some time.

All surviving miners being busy at the mine, men were sent from surrounding towns to dig graves. On Friday a number came horseback from the nearby large town of Stigler, bringing with them tools and regardless of the rain spent 6 hours digging graves. Most of the victims were buried on Friday. At the mine the night workers were supplied with lunch that consisted of but little more than hot coffee and bread, but no one was heard to complain.

The miners that were killed were largely American. Forty-nine out of 73 had English names. Nearly all were English speaking. Some eleven or twelve Italians were the principal foreign element. The able Italian consul was of great assistance in caring for these men and their families. There were a few Slavonians, Lithuanians, French, and Germans. The miners of No. 2 mine are able to earn more per day than those of either of the other mines of the camp. As a result, the best miners and those longest in the camp worked in this mine. A few of them thought the mine too dangerous and remained at the other mines. The miners killed were thus of the best in the camp. It is estimated that more than half of them lived in homes owned by themselves or near relatives.

It is estimated that between 15 or 20 families are left in straitened or destitute circumstances. The regular biweekly pay day fell upon the Saturday following the explosion and the money then paid out fell in good ground. District No. 21 of the United Mine Workers of America immediately set aside \$5,000 for the relief of the destitute.



Coal Mining Notes

Track and Haulage.—One of the most neglected features in many coal mines is the track. At a certain mine all-steel dust-proof cars are objected to because, when in a wreck, they are apt to be so badly crushed as to be beyond repair at anything like a reasonable price. At the place in question the heading, a very long one, is laid with very heavy steel, has numerous sharp grades and a 20-ton haulage motor is used to handle the old type, wooden cars. In the glare of the search light on the motor the track is a "sight." It is as crooked as the proverbial black snake; one rail is 2 inches higher than the other in places and, again, that much lower; the dips are 2 inches over the rail in mud, and at the numerous "soft" places the track springs several inches under the weight of the cars. Also, the wheels do not appear to be of absolutely the same size and the axles of the cars are anything but parallel. And yet speeds of 25 to 30 miles an hour are attempted with such a roadbed. The trouble is the very usual one, that operators have failed to realize that with improved and heavier motors and higher haulage speeds the roadbeds suitable for mule haulage, low speeds, and small output are no longer adaptable. Imagine attempting to run the Pennsylvania Limited at 60 miles an hour over the roadbeds of 1864. Yet this is substantially what all but one in a hundred of mine managers are attempting to do today. See to it that the engineers and foremen have the headings driven absolutely straight; that is what they are hired for. Lay one rail on the line of sights; use heavy ties and 50- to 60-pound iron; fill in or drain the dips and have a regular section gang to keep the roadbed in shape. By doing this and having car wheels of the same diameter and the axles absolutely parallel, speeds of 40 miles an hour with consequent increased output may safely be maintained underground and, in addition, steel cars will not be the bogie they now are.

A Use for Old Fan House.—A most excellent use for old mine buildings is one devised by Mr. James Cameron, superintendent at Hastings. The fan having been replaced by a larger one at a new location left him with a substantial concrete fan house convenient to the drift mouth. Instead of tearing this down, Mr. Cameron

has converted the building into a comfortable temporary hospital intended primarily for single men living at the "boarding house" who may be injured and need some place where they may receive proper attention before being removed to a regular hospital. Any one familiar with the boarding house at the average mine will appreciate what a boon this will prove in emergencies to unmarried men who may be injured.

Changes in the Shenandoah, Pa., District.—A. D. Gable, who has for many years been outside foreman for the Philadelphia & Reading Coal and Iron Co.'s West Shenandoah, Kohinor, and Turkey Run collieries, has been appointed outside district superintendent for the company in the Shenandoah district. Mr. Gable is one of the company's oldest employees. The collieries which will come under his supervision have heretofore been a part of the Ashland district, under the supervision of William A. Saubrey. As the district was the largest under the company, and the collieries widely separated, it has been divided.

Pocahontas Coal and Coke Shipments.—The annual statement of the Crozer Land Association giving the yearly and total gross tons of coal and coke from the Pocahontas Flat Top field in West Virginia has been received. While the original Pocahontas mine is in Tazwell County, Va., it obtains the greater part of the coal it loads at its tipples from West Virginia, and is counted in the summary. Since 1883, when the Pocahontas mine shipped 60,283 tons of coal, the output from the Flat Top field has increased until in 1911, 69 collieries shipped 11,290,400 gross tons. In the years 1895, 1896, 1897, and 1908 the coal production showed no increase, but each of the remaining 25 years have shown an increase. The increase in 1911 over 1910 amounted to 1,020,819 tons. In 1883 the original Pocahontas Coal Co., now the Pocahontas Consolidated Co., shipped 19,805 gross tons of coke; in 1909 there were 2,189,362 tons of coke shipped and in 1911, 1,172,240 tons. This great falling off in coke shipments is due to the United States Coal Co. decreasing its output from 721,261 gross tons in 1909 to 54,184 gross tons in 1911; in addition there was a further curtailment of coke production amounting to 350,039 gross tons. The United States Coal Co. has been shipping its coal to the by-product ovens of the United States Steel Corporation of which it is a subsidiary.



Trade Notices

New Rock Crusher Co.—P. E. Garretson and associates have purchased from Samson Mfg. Co. all rights for the manufacture of the Samson rock crusher. The company will not confine its business to the mining industry alone, as this crusher is adapted for all kinds of rock breaking, such as rock for concrete, road work, etc., lime, cement, coal, and other products, where a uniform product is desired. The business will be continued under the name of the Samson Mfg. Co., with main offices at 1738 Broadway, Denver, Colo., and branch agencies will be established in different parts of the United States, Canada, and Mexico.

Mining Pumps.—In a catalog recently issued the Gardner Governor Co., of Quincy, Ill., describe an outside center-packed plunger pump which they state is desirable for mining purposes. These pumps will pump water containing grit, sand, or gravel, which would quickly cut out and render ineffective the ordinary fibrous packed piston, or plunger and ring patterns. The plunger is exposed and can easily be kept lubricated, and packing is also on the outside, which permits the pump to be repacked at any time with very little trouble.

New Coal Plants.—Roberts & Schaefer Co., engineers and contractors, of Chicago, have contracted with the Campbell's Creek Coal Co., Cincinnati, Ohio, for a Stewart coal washing plant, to be built at the Dana (W. Va.) mines, also they will build for the Western Maryland Railway four large Holmen coaling stations, two having a storage capacity of 500 tons each, to be built on the line at Hagerstown, Md., Cumberland, Md., Rockwood, Pa., and West Virginia Central Junction, W. Va. Roberts & Schaefer Co. will also build a complete fireproof coal

mining plant for the Nigger Head Coal Co., of Walsenburg, Colo., and one for the Pembina Coal Co., Ltd., of Edmonton, Alberta.

"Pocket Smelter Week."—The Way's Pocket Smelter Co., of South Pasadena Cal., announces that every person buying either a field or office Pocket Smelter outfit during the week of May 5 to 11, inclusive, is to receive free a valuable premium in a mining book, or a cigar lighter (either of which sell regularly at \$1.50), also an enlarged booklet of instructions, containing valuable mining information. Every outfit sold during "Pocket Smelter Week" is to be guaranteed by a National Bank, and if the purchaser is not absolutely satisfied, the money paid is to be promptly refunded, together with transportation, and other costs.

Mine Trolley Harp and Wheel.—The Ohio Brass Co., of Mansfield, Ohio, is introducing a new design of trolley harp and wheel. A feature of the harp is the provision made for rotating manually, thus enabling the motorman to guide it easily through frogs, over particularly uneven places in the trolley, etc. The pivot bolt, fastened to the harp casting, passes through the pole-end casting and is provided at its lower end with an eye which rotates with the harp. A stick or strap, attached to this eye, enables the operator to control the harp at all times. The harp is also designed to operate automatically; the center of the wheel axle is set back of the pivot point so that a trailing action is imparted to the harp, causing it to readily follow irregularities in the trolley wire and take sharp curves without pulling the wheel from the wire. A rib on the top of the pole-end casting prevents the harp from catching on overhead I beams in case the wheel leaves the wire. The harp is made of malleable iron spherulized, or with bronze harp casting and malleable iron pole end and will take all standard 4-inch mine wheels with $\frac{1}{2}$ " \times $1\frac{1}{2}$ " hubs. The wheel has heavy flanges which resist bending, and a heavy section of metal at the bottom of the groove where the wear is heaviest. It is made of an alloy that is carefully mixed and is analyzed at every heat, thus ensuring uniform metal. Perfect lubrication is provided by an oil reservoir in addition to a Bound Brook type bushing with graphite inserted in grooves in the special bearing metal of which it is made. The bushings are $1\frac{1}{2}$ inches long and $\frac{1}{2}$ -inch bore and the wheel will fit any standard harp.

New Plant.—The American Rubberfelt Co. of Chicago, has purchased a property at Elston and Webster avenues on the Chicago and Northwestern Railroad and the north branch of the Chicago River, and will occupy it for manufacturing and office purposes. The ground area is 36,800 square feet and there is a concrete dock and private switch track. The company is best known to readers of MINES AND MINERALS as a manufacturer of Rubbertex brattice cloth; and also makes a membrane system of waterproofing, a building material extensively used for waterproofing basements, tunnels, and similar structures.

An Advertising Company has been organized by William L. Rickard and Clifford A. Sloan who will conduct business under the corporate name of Rickard & Sloan with offices in the Evening Post Building, 20 Vesey Street, New York. Attention will be given to the planning and management of advertising campaigns for concerns engaged in the manufacture of mechanical and electrical apparatus and accessories. The service of the company will include the writing and placing of advertising in trade papers and other periodicals, and the production and distribution of bulletins, catalogs, and circulars and the usual work of an advertising agency.

Murray Specialty Mfg. Co.—The Murray Automatic Boiler Feed Co., of Detroit, has been taken over by the Murray Specialty Mfg Co., who will continue the manufacture of all the Murray steam specialties. This company, while a separate and distinct organization, is under the same management as the Wright Mfg. Co. and the Austin Separator Co. and will have the same capable and energetic management which has put the Austin and Wright products in the front rank. The merits of

Murray automatic oil or feed regulators, pump governors, double-disk blow-off valves and other devices are well known. The Murray boiler feed regulator is of especial interest. It automatically holds the water in the boiler at the center gauge, thus furnishing dry steam to the engine, preventing the possibility of accidents from low water, and effecting a saving in fuel. Whenever the water in the boiler falls below its normal level, the float in the column will open a needle valve and admit steam into the lower end of the cylinder, forcing up the piston against the tension of the spring and, through the piston rod, opening the regulating valve. This will admit water through the feedpipe into the boiler until the normal level is restored. Then the needle valve will again be closed by the rising of the float shutting off the steam and allowing the spring to compress the piston, closing the regulating feed, or valve.

Correction.—In the April issue in referring to the removal of the Pennsylvania Storage Battery Co., the new address was incorrectly given. Both the office and factory are now at 221-227 North Twenty-third Street, Philadelphia, Pa., where the well-known line of batteries, lamps, and electric specialties will continue to be made.

Taylor Iron and Steel Co.—At the annual meeting of the stockholders of the Taylor Iron and Steel Co., held at High Bridge, N. J., on March 5, 1912, the annual report showed that the earnings for the year 1911 were very satisfactory, although there had been a falling off of business as compared with 1910. The company reports its plant and equipment, through recent extensions and additions, to be in excellent condition to handle a large business. The following were elected. Directors: Henry M. Howe, Knox Taylor, L. H. Taylor, Jr., E. H. Earnshaw, H. J. Cochran, Edgar S. Cook, A. E. Borie, V. G. Simkhovitch, James Imbrie. Officers: Knox Taylor, president; A. E. Borie, H. M. Howe, vice-presidents; W. A. Ingram, secretary and treasurer.

An Improved Anemometer.—An improved form of the Biram anemometer, called the Davis-Biram, has been brought out by John Davis & Son (Derby), Ltd., England, who also have offices at 110 Fayette St., Baltimore, Md. The air enters, as usual, from the back of the instrument, and instead of passing in a straight line through the protecting ring, is deflected outwards, by a cone, through port holes. The friction of the air passing through the instrument to the outer air is practically nil. Experiments have proved that if the instrument is held 18 inches from the operator's body, there is no hindrance to the free current of air, and that the accuracy of the readings is not interfered with. Another advantage is that a distinct dial face, covering the whole circumference of the protecting ring, can be constructed. The instrument has four dials, a central hand traveling over the 3-inch-diameter dial reading 100 feet in one revolution. The respective dials read 100, 1,000, 10,000, and 100,000. The instrument is delicately poised and strongly protected. The curve showing the percentage to be added or deducted at various velocities is extremely level throughout the chart (as shown by tests made at the National Physical Laboratory) from about 100 feet to over 3,000 feet per minute. A handle through which a plunger passes screws into the instrument, so that the operator can hold the anemometer and connect or disconnect the revolving fan from the train of wheels with one hand. The dials can be run to zero, and, as the instrument records up to 100,000 feet, it can be run in the dark and then brought to a good light to read. Although this instrument has been tested up to 3,000 feet per minute without injury, it has been thought desirable to provide against any possible damage in high velocity. When desired, the instrument is supplied with a shutter which reduces the port holes, and in testing for velocities, say above 30 feet per second, the shutter is slid over the port holes. The results then have to be multiplied by two. At lower velocities care must be taken to see that the shutter is fully open.

The manufacturers also make other instruments for mine work, including water gauges, barometers, hygrometers, thermometers, electric blasting apparatus, and miners' safety lamps. Complete description and price list can be obtained by writing either to the Baltimore or Derby office.

乘
Correspondence
乘

Method of Working a Vertical Bituminous Coal Seam

Editor Mines and Minerals:

SIR:—I will probably soon have to develop a seam of bituminous coal 16 feet thick, with a run of 1 mile on the strike of the seam. The seam stands practically vertical and runs to a depth of 1,000 feet. I would be pleased to have some of the practical mine officials or mining engineers who read MINES AND MINERALS suggest methods of development by means of which such a seam can be worked to best advantage.

MINING ENGINEER

Farmington, Ill.

Rubbing Surface of Airway—Correction

Editor Mines and Minerals:

SIR:—Is not Ques. 12 in the March issue of MINES AND MINERALS answered wrong?

WILLIAM TUCKER

Rathmel, Pa.

It is, because both entries have the same area, and the 14×3 entry has the most rubbing surface. In the last line of the answer the word most should read least.—EDITOR.

Specifications for Oil

Editor Mines and Minerals:

SIR:—In reply to F. D. B. concerning specifications which cover oils for different purposes, I would state that should one set down a formula of the cylinder stock from a certain crude oil, it might be condemned, due to mechanical defects for which the oil is generally blamed until the complaint is sifted down. My personal opinion is that too much care and watchfulness cannot be given the vital parts of an engine, the valves and cylinder; the rest we can readily see and give attention immediately.

What can one expect of a heavy piston dragging back and forth with rings so sharp they will cut one's finger. These sharp rings shave the oil off the walls of the cylinder as fast as it is applied and very often the oil is condemned on this account. How difficult it would be for one who was honest to say that this or that oil is what should be used unless the conditions are known. So I earnestly recommend your subscriber to obtain the services of some good man and go over his mines and plants, study his conditions, and then apply a remedy.

W. E. C.

Pittsburg, Pa.

Method of Shaft Plumbing

Editor Mines and Minerals:

SIR:—Enclosed you will find a sketch, also the analysis, of a method of shaft plumbing that I have used for the first time. While I do not claim that the method is new, it is possible that some of your readers are not familiar with this scheme. It has a few special advantages which are listed as follows:

(a) The wires are suspended on the outside of the cages and close to the guides (in this way allowing the cages to be operated), as there is usually 4 to 8 inches clearance. This is an especial advantage if only one opening into the mine has been completed.

(b) Both the distances measured are from points which are fixed and in this way accurate measurements may be gained.

(c) A valuable check is to measure the distances from the inside dirt to the wires.

(d) The inside points are located close enough to the plumb line to give the angles (α , β , θ and γ) at least 20 degrees or over, in this way eliminating errors which creep into the work, due to mistakes of reading the instruments to angles less than minutes.

(e) A suggestion would be that the angle between the lines AB and DE in Fig. 1 be between 70 and 80 degrees. Analysis is as follows:

Given: Angles θ , β , α , and γ , also distances DE and AB , both of which are measured from solid points, and are accurate.

To find angle EOA , $\text{tang } \alpha = \frac{EF}{FA}$.

Proof: $\text{tang } \theta = \frac{EF}{BF}$

but $EF = BF \cdot \text{tang } \theta = FA \cdot \text{tang } \alpha$

also, $\frac{BF}{FA} = \frac{\text{tang } \alpha}{\text{tang } \theta}$

$\frac{BF + FA}{FA} = \frac{\text{tang } \alpha + \text{tang } \theta}{\text{tang } \theta}$

by adding 1 to each equation

$BF + FA = AB$ a known distance

therefore, $FA = \frac{AB \times \text{tang } \theta}{\text{tang } \alpha + \text{tang } \theta}$

Similarly, by using angles β and γ the distance BG is found.

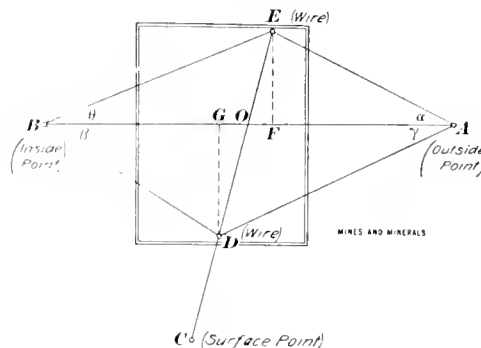

FIG. 1

Using similarly the triangles DGO and OFE (2 angles equal)

$\frac{GO}{OD} = \frac{OF}{OE}$ or $\frac{GO}{OF} = \frac{OD}{OE}$

$\frac{GO + OF}{OF} = \frac{OD + OE}{OE}$ (by adding 1 to equations)

but $GO + OF = GF$ and $OD + OE = ED$ both known

therefore, $\frac{GF}{OF} = \frac{ED}{OE}$ also $\frac{OE}{OF} = \frac{ED}{GF}$ but $\frac{OE}{OF} = \cos EOA$

therefore, angle EOA = an angle whose cosine is $\frac{OE}{OF}$.

E. F. WOODSON

Kansas City, Mo.

Iron Ore in Fulton County, Pa.

Editor Mines and Minerals:

SIR:—Under date of March 20, a press dispatch from Pittsburg, Pa., announced the discovery in Ayr Township, Fulton County, Pa., of a great bed of iron ore aggregating billions of tons. It stated that there were three kinds of ore, red hematite estimated at more than 250,000,000 tons, brown hematite in about the same quantity, and carbonate of iron to the extent of more than half a billion tons. The ore was stated to be in three spurs of the Blue Ridge Mountains known as Meadow Ground Mountains, Lowries Knob, and Dickey Mountain. This remarkable discovery in an isolated part of the state, in the only county in Pennsylvania without railroad connection with the outer world, was made by J. W. Crossland, of New Florence, Pa., who is stated to be a mining engineer and geologist of 30 years' experience. Inasmuch as the locality, while isolated, was settled over a hundred years ago, and in the old days of charcoal furnaces some rather inferior ore was mined and smelted, the knowledge of the existence of iron ore in the territory mentioned is over 75 years old.

The name of the "mining engineer and geologist of 30 years' experience" does not appear in the list of members of the American Institute of Mining Engineers, to which society most of the leading American mining engineers and geologists belong. Inquiry made of prominent geologists and mining engineers regarding Mr. Crossland

either brought replies that he was unknown, or no reply at all. It seems queer also, that a mining engineer and geologist of 30 years experience would not have been familiar enough with Volume T2, of the Reports of the Second Geological Survey of Pennsylvania, to know that the peculiar geological formation he came across on Meadow Mountain was probably the Cove fault mentioned and described in that volume. The dispatch says he came across nodules of ore known to geologists as "iron ore float," and after careful investigation he reached the conclusion that there were valuable deposits of iron ore in the mountains and vicinity. In summing up his findings he is quoted as saying: "It is not a disseminated body of ore, but is an immense mass of iron ore with the *dross burned out*, hundreds of millions of tons not excelled by any ore in the United States today in high percentage of metallic iron and its purity, a true Bessemer ore."

"He found nodules of ore." On these finds he built his wonderful story, and his estimates of the great quantity of ore. Ordinary engineers and geologists looking for ore bodies do not regard nodules of ore as more than an indication of iron ore which may lead to a bed in the neighborhood, and they never attempt to gauge the size of the bed from nodules picked up on mountain sides or in the valleys.

As stated before, the knowledge of the existence of iron ore in the locality mentioned has obtained for many years, probably a century. In the first half of the nineteenth century small charcoal furnaces produced iron from this ore. Volume T2 of the Reports of the Second Geological Survey by J. J. Stevenson, who in the early eighties examined and studied the geology of Fulton County for months, and who had every facility to get reliable data regarding the geology of the county, describes that of Ayr Township and particularly the three mountains mentioned quite fully.

This report shows that there is iron ore in the locality mentioned, and that many years ago it was smelted in small furnaces long since abandoned and now crumbling ruins. At the foot of Dickey's Mountain, one of the three spurs of the Blue Ridge in which the remarkable deposit is said to occur, Mr. Stevenson located old mines worked some 65 years ago to supply ore for the old Hanover Iron Works, long since abandoned. In commenting on this ore, Mr. Stevenson said: "Very little ore was taken out and there is reason to suppose that the bed was not found. For the most part this ore is coarse and silicious, containing only about 38 per cent. of iron. The mining was abandoned because the ore proved to be very inferior." He also reports that iron ore is plentiful in the Meadow Ground Mountain, but as far as could be determined by fragments scattered over the surface, its quality is extremely variable, and most of it is too silicious to be of any use.

At Lowries Knob are the old Hanover iron mines, which were worked for nearly 25 years to supply the Hanover Iron Works, where operations ceased in 1847. The annual yield of these mines is said to have varied from 1,200 to 2,000 tons, but the deposit is believed to contain much ore still. It is a compact brown hematite of the following composition: Metallic iron, 46.100; sulphur, .115; phosphorus, .083; silicious matter, 21.500.

Mr. Stevenson states that ore was obtained at one time on the west side of Lowries Knob, but the quality appears to have been somewhat inferior and the mine was abandoned.

What the object of this fairy tale, as published in the daily papers is, is unknown to the writer. It may be to advertise the discoverer, or it may be the forerunner of a scheme to organize a company and market its securities. If the latter is the object we would advise your readers to insist on positive proof of the existence of not only the ore in quantity, but also in quality before investing.

采 采

F. J. R.

All cylinders, receivers, and pipes of an air compressor should be frequently cleaned of accumulating oil, deposited carbon, and organic dust. The air intake should be located where an abundant supply of pure cool air may be obtained. Without these precautions carbon dioxide may be produced from the heated carbon deposits. This will suffocate and kill miners, if supplied to air drills.

The Colorado Lignite Strike Situation

An agreement signed March 5, between the officers of the American Fuel Co. and the United Mine Workers of America, settled a strike in eight of the largest coal producing mines in northern Colorado. Both sides claim a partial victory, but it would appear that the strikers have prevailed. The several local unions have ratified the agreement and work was resumed in the eight northern mines of the company in question.

The strike commenced April 1, 1910, and the American Fuel Co. officers and union leaders state that it has cost them jointly \$1,000,000 in loss of wages and business.

The mines operated by the American Fuel Co. are the Centennial, the Matchless, and the Electric, at Louisville; the Capitol, and the Senator, at Lafayette; the Fox, at Marshall; the State, at Erie; and the Evans, at Frederick. The non-union men at work in these mines were notified of the agreement and given two days to secure employment elsewhere. Many of them have gone to the mines of the Rocky Mountain Fuel Co.

The agreement between the miners and the American Fuel Co. is to continue until April 1, 1914. Sixty days before that date notice is to be given of the expiration of the agreement and conferences are to be held to renew it or make such changes as each side deems advisable. If, at the end of 60 days, no agreement has been reached, the agreement shall continue in effect until another one is reached.

The agreement of 1908 is adopted with the changes and increases agreed upon at the recent conferences. The agreement states that the miners on strike shall have preference for work.

Under the Louisville scale, or 1908 agreement, the old prices paid were 39½ cents a ton for loading after machines in beds over 6 feet thick; 43½ cents a ton for loading after machines in beds under 6 feet thick; 62 cents a ton for pick work in beds over 6 feet thick, and 68⅔ cents a ton for pick work in beds under 6 feet thick. Three cents per ton to each of these prices will be added by the new agreement.

The day wages under the 1908 agreement ranged from \$2.50 for firemen, helpers, and laborers, to \$3.50 for machine runners. The majority of the men averaged \$3 per day. Under the increase of 5 per cent. for this class of work, the operators announce that the men will average \$3.15 per day.

The agreement was signed by John R. Lawson, International Board Member of the United Mine Workers of America for Colorado; William Crawford, secretary, and Frank Smith, president, of District No. 15; and David E. Evans, president, and Miss M. H. Vaughan, assistant secretary, for the American Fuel Co.

John McLennan, President of the Colorado State Federation of Labor, took part in all of the conferences.

The new scale affects the operations in the mines of this company only. The other operators in the field are still adhering to their disregard for union demands.

The Rocky Mountain Fuel Co. has ten mines in the northern field, and the capacity has been from 3,000 to 3,500 tons daily, according to Vice-President Brown. The mines are at Louisville, Lafayette, Marshall, and Superior. When the 1,000 miners go to work in the mines of the American Fuel Co. there will be from 600 to 800 strikers still out of work.

D. W. Brown, vice-president of the Rocky Mountain Fuel Co., said: "Our position is the same as it has been in the past. We adopted a policy which refused to recognize the union. We are going to adhere to that policy. Our views have not changed in the least. We might recognize the union a hundred years from now, but not at present. We do not feel that the settlement is going to affect us in the southern fields, where we have a number of mines."

The Rocky Mountain Co. sought the aid of the Federal Court several weeks ago by filing a petition for an injunction, alleging that the coal towns were in a state of lawlessness.

The National Fuel Co. operating the Van Mater mine, has declined to compromise with the union.

Bruceton, Pa., Explosion

A Description of the Explosion Test at the Experimental Mine, on February 24, 1912

By George S. Rice*

On the morning of February 24, 1912, there was conducted at the Experimental Mine, near Bruceton, Pa., the fourteenth and last of the first series of explosion tests.

The mine consists of a pair of entries in the Pittsburg seam, about 750 feet long from the outcrop opening to the face. These entries are connected by three cross-cuts 200 feet apart. In the first of these going into the mine is a reinforced concrete stopping, the behavior of which in the explosion was one of the points of interest, since the stopping was built with a predetermined strength, which was estimated to be from 150 to 200 pounds to the square inch, applied at right angles to the surface. The second cross-cut had a sandbag stopping 15 feet thick, supported by a timber frame.

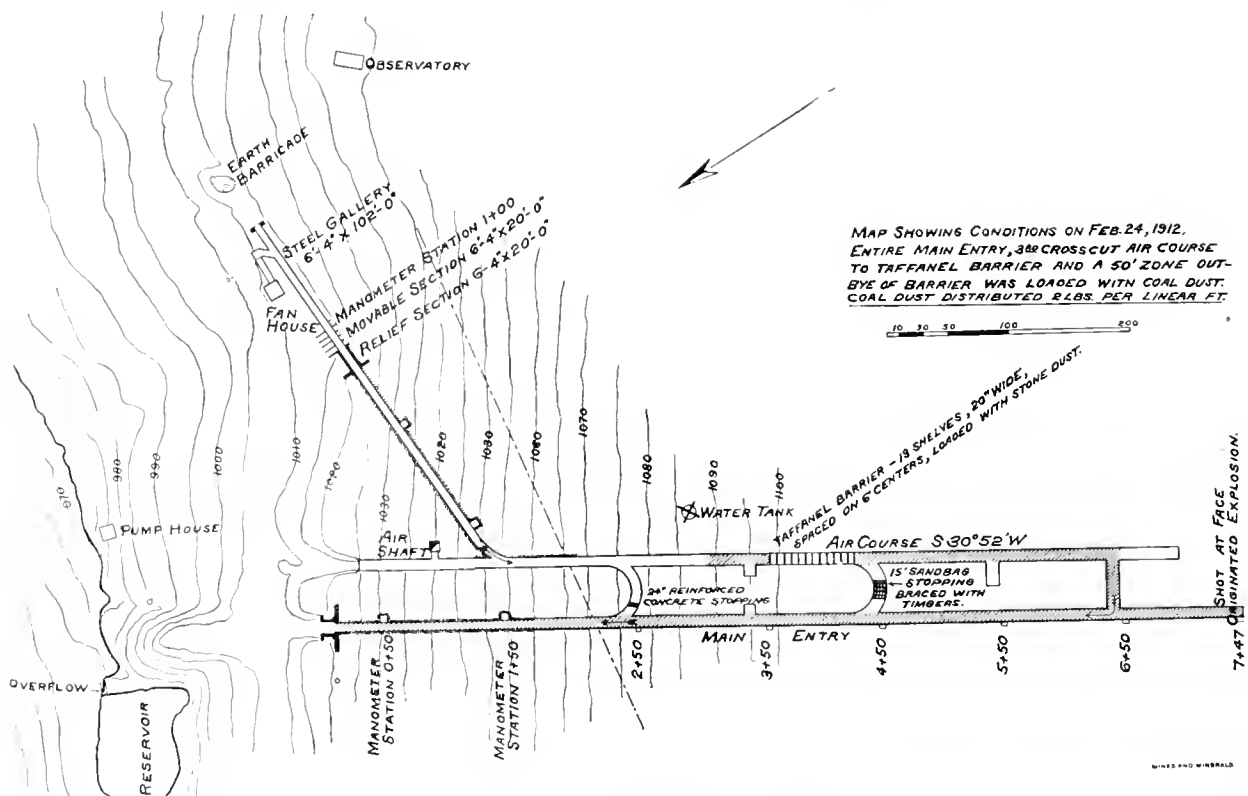

FIG. 1. MAP OF EXPERIMENTAL MINE, BRUCETON, PA.

The third cross-cut was open so that the ventilating current could pass through. The fan was located at the end of an external 120-foot steel gallery leading into a passageway lined with reinforced concrete, which in turn, entered the air-course, or left-hand entry of the pair of entries above described. The fan at the time of explosion acted as a blowing fan, the air entering the steel gallery and passageway to the air-course, up same to the last cross-cut, then into the main entry, returning on the latter to the outside.

The entries, or passageways, are about 7 feet high and 8 to 9 feet wide, which are the usual dimensions in mines in the Pittsburg bed. In this mine the latter is from 5 to 5½ feet thick. There is a "draw slate" 1 to 2 feet thick, and above this an upper band of coal 6 inches to 2 feet thick, too full of slate to be of value, but making a fair roof. The outer 150 feet of the main entry is lined with reinforced concrete.

For recording pressures, velocity of the pressure wave, and the velocity of the flame wave, instruments were placed at stations 100 feet apart. The wires connecting same are intricate, there being some 31 separate wires in the cable which leads from the face

* Chief Mining Engineer, United States Bureau of Mines.

of the mine through the different stations to the outside. From the entrance, where there are locked cut-out switches on the firing circuits, the cable is taken overhead to the bomb-proof observatory in which some of the recording instruments are placed, and which is also the control station.

While many kinds of tests will be carried on in the Experimental Mine, the principal object at the present time is to determine how and why coal dust explodes, in order that remedies for prevention and limitation may suggest themselves from the experiments and subsequently be tried out. It is for the purpose of understanding the nature of coal-dust explosions and for the comparison of the effects obtained by the different remedies that the instruments are provided, as otherwise it would not be known whether the checking or prevention of the dust explosion was a matter of accident or otherwise.

In order to obtain consistent results, the coal dust employed in the test must be of known kind and size and be distributed evenly. To accomplish this, shelves 3 inches wide are placed along the walls and the coal dust is placed on these. In the test of February 24,

1 pound per linear foot was placed on the floor of the entry. In the previous public demonstration and explosion of October 31, 1911, 1 pound per linear foot had been used on shelves, but none on the floor. In other words, in the explosion test of February 24 double the quantity was used.

The real consideration in loading is the amount per cubic foot of space, since a limiting effect in any explosion is the quantity of oxygen available for the combustion. If the coal dust is completely burned, it takes but twelve one-hundredths of an ounce of ordinary bituminous dust to use up all the oxygen in a cubic foot of air. As a matter of fact, there is rarely complete combustion; usually there is a considerable amount of unconsumed volatile matter and with the large particles of dust most of the fixed carbon is not consumed. The gases of the coal are thus chiefly brought into play. When the loading of the Experimental Mine entries is 2 pounds per linear foot there is about sixty-four one-hundredths of an ounce of dust per cubic foot of air, or five times that which is theoretically necessary to use up all of the oxygen.

On February 24, the coal dust loading in the main entry reached from the mouth to the face. The loading was also continued through

the last cross-cut into the air-course and out along the same for 200 feet. At this point there was placed a Taffanel stone-dust barrier, which consists of a group of shelves, in this case 13, placed across the passageway about 5 feet above the track, these shelves being placed about 6 feet apart center to center. Each shelf consisted of two boards, 10 inches wide, and 1 inch thick, making a total of 20 inches, on which finely ground stone was placed. There was about 4 cubic feet of stone dust on each shelf, or about 240 pounds per shelf. This "arresting barrier" has been particularly developed by M. Taffanel, at the Lievin, France, testing station, where in external gallery experiments it has proven very effectual in arresting coal-dust explosions, and the system has been very generally adopted in French coal mines. On the other hand the British investigators under the lead of Mr. W. E. Garforth, as a result of the experiments in the Altofts gallery, have considered it necessary to spread the stone dust continuously through the mine.

Beyond (outby) the stone-dust barrier, coal dust was spread along 50 feet of entry, to see if the explosion would pass the barrier and ignite the coal dust. Small tufts of loose guncotton (loose guncotton is inflammable but not explosive) were placed at intervals throughout the mine to determine the extent of the flame independently from the flame circuit-breakers in the main entry.

The initiation of the explosion was at the face of the main entry, by a single blown-out shot of 3 pounds of black powder stemmed with 5 inches of fireclay. In order to insure that the shot would blow out, the hole was cased with 1½-inch pipe. A similar hole was prepared in case of the failure of the first, but it proved not to be needed, so was not fired. The shot was ignited by an electric detonator connected through the cable with the observatory. The wires of the flame circuit-breakers and of the pressure manometer were placed immediately in front of the hole so as to obtain a record of the moment that the shot was discharged.

Explosion, and the Results.—After the party of mine inspectors and others interested in mining had inspected the mine, Mining Engineer L. M. Jones and Mine Foreman H. C. Howarth (all others having left the mine) connected up the wires to the shot that was to cause the explosion. When they came out, the cut-out switches at the shaft and observatory were thrown in, and after a preliminary whistle, a button at the observatory was pressed, which fired the igniting shot. Two and one-half seconds later out of the main entrance there burst a great cloud of black dust and smoke, through which a flame darted. A sharp heavy report, like the sound of a great cannon followed; the cloud of dust kept rolling out until the ravine was filled. A window was broken outwardly in a house which stood not in line with the entries but at right angles to their axis, and across the valley, about half a mile distant.

Some smoke and dust had been thrown out of the air-course entrance, but very little from the gallery passage leading to the fan; no flame appeared from these openings. The fan was not stopped nor damaged in any way, as had happened in the explosion of October 31. Subsequent examination showed that the flame in the air-course had stopped 75 feet from the outside. The explosion had evidently come up to the stone-dust barrier with great force, smashing it to pieces, and the flame had extended beyond, but the stone-dust thrown into the air had apparently cooled and checked the explosion. While the coal dust did not extend to the outside of the mine, in the air-course there was sufficient excess of dust thrown out to have carried the flame to the outside had not the explosion in the air-course been checked by the barrier. It is particularly striking that the fan was not stopped nor damaged by the explosion, nor was a thin stopping of 1-inch boards placed across the steel gallery, injured or broken; whereas, in the explosion of October 31 when there was no stone-dust barrier, the flame had traversed the gallery as far as the fan, breaking out a 2-inch stopping, and blowing the fan casing apart.

Fifty feet in front of the main entrance an empty car had been placed prior to the explosion; this was blown across the ravine, a distance of about 200 feet. Some fragments of concrete from the concrete lining had also been carried to the outside, and two wooden gates in recesses, recessed behind the entrance buttresses, not

exposed to the direct blast had been carried away with the gate posts, and blown to pieces. The mouth of the main entrance was not damaged. The concrete reinforcement is very heavy. The greatest evidence of force was shown between stations 50 feet and 150 feet from the mouth of the mine. At station 50 the top of the entry had been lifted, the reinforcement pulling through the concrete. Inby station 150 some of the 3"×4" hardwood shelving which was bolted to the sides had been demolished by the force. The pressure shown at station 150 by the Cambridge manometer was over 110 pounds per square inch. This pressure is measured at right angles to the explosive wave. The shelving had also been demolished at several other points further in. Inby the station 150 the track ballast had been loosened up, evidently by the vacuum wave following the pressure wave.

The reinforced concrete stopping in the first cross-cut was found to be intact; the sandbag stopping 15 feet thick in the second cross-cut had been partly blown down; 2 to 3 feet had been blown off the



MINES AND MINERALS

GEORGE S. RICE, CHIEF MINING ENGINEER U. S. BUREAU OF MINES

top, some of the bags toward the air-course and some toward the main entry. In the third and open cross-cut there was much evidence of flame shown, and there was considerable coked coal dust on the ribs and attached to the roof. Going from the second cross-cut to the first there was little violence indicated, and except in the immediate vicinity of the shot there was almost no violence indicated in approaching the face. The shot had burst the iron casing, and had blown down some coal. The flame and circuit-breakers indicated that the speed of the explosion was quite slow at the start, 200 to 400 feet per second, but further out it attained a speed of over 2,000 feet per second. At the time of writing this informal report the records of the instruments had not been fully worked out by Dr. J. M. Clement, physicist, and his assistant Mr. W. L. Egy, who are in charge of the recording apparatus.

Summary.—The special points of interest indicated by the experiment were:

1. That an excess of coal dust over that required for the maximum result will not check an explosion.
2. That the Taffanel barrier, under the conditions tried, appears to check an explosion that has not traveled over 340 feet.

This must not be considered a final proof, but merely as a successful result of one single test.

3. That a speed of over 2,000 feet per second is attained by the flame of a coal-dust explosion when it has reached a "detonating" stage.

On the whole this last experiment was not so spectacular as that of the public demonstration of October 31; the flame on the exterior was less, not only from there being none issuing from the fan gallery, but also there was less at the main entrance. On the other hand the speed of the explosive wave indicated by the instruments, was greater in the experiment of February 24. Unfortunately there can be no comparison of the pressures inasmuch as the instruments were not equipped with sufficiently heavy springs in the former experiment. It seems probable from the general effects on the concrete arching that the pressures in the main entry were not dissimilar in the two cases, but owing to the barrier in the air-course they were less in that part of the mine in the latter experiment.

來 來

Deep Coal Mine Shafts

Probably nothing is more interesting to students of mining and others than the comparison of deep shafts for different purposes. The deepest shafts in the Pennsylvania anthracite region are in Luzerne and Schuylkill counties. To the Philadelphia & Reading Coal and Iron Co. belongs the deepest shaft. It is the Brookside in the Lykens Valley, Schuylkill County, and has a depth of 1,854 feet. The Auchincloss shaft at Nanticoke is the second deepest. It is owned by the Delaware, Lackawanna & Western Railroad Co., and has a depth of 1,726 feet.

The Dorrance shaft in Wilkes-Barre is 1,127 feet deep.

The Kingston No. 2 shaft in Dorranceton, near Wilkes-Barre, is 1,147 feet deep.

The Inman shaft in Hanover Township, Luzerne County, is 1,146 feet deep.

The Gilberton shaft in Shenandoah is 1,070 feet deep.

The Hammond shaft in Connerton, Schuylkill County, is 1,200 feet deep.

The Kaska William No. 2 shaft in Schuylkill County is 1,370 feet deep.

The Wadesville shaft near Pottsville is 1,576 feet deep.

The shaft having the least depth is in Lackawanna County and is known as the Riverside in Winton. It is owned by the Scranton Coal Co. and has a depth of 276 feet.

In the Pennsylvania bituminous region the shafts run from 300 to 697 feet in depth. The deepest shaft in the bituminous field of Pennsylvania is the Coleman shaft, operated by the Maryland Coal Co., of Pennsylvania, at St. Michael, Cambria County. The hoisting shaft is 697 feet deep.

In Germany the depth of coal mines is rapidly increasing and it is estimated that in the next 10 years they will have reached 2,000 feet or more in the Dortmund district. At present they average 1,700 feet, the limits being 1,000 and 2,600 feet. The country along the River Lippe contains coal deposits which have been tested and found to reach to a depth of as much as 3,280 feet. These will probably be worked before very long. At a mine near Chemnitz there is a coal pit 3,117 feet deep, and at Dortmund the maximum working depth is 2,625 feet.

The deepest hole in South Africa was made with a diamond drill and put down 6,340 feet to cut the main reef. The hole was 2 inches at the start and 1½ inches in diameter at the bottom. A million dollars was used.

The deepest oil well drill hole near Los Angeles is 5,323 feet. The deepest well in the United States is near West Elizabeth, Pa. Its bottom is 5,575 feet beneath the surface. According to the United States Geological Survey the most remarkable well ever drilled was probably 3,600 feet deep. This was drilled for petroleum in Western China by primitive methods, and by means of such crude appliances as a cable made of twisted strands of rattan.

What is claimed to be the world's deepest boring is a hole 2,249 meters, or 7,347 feet deep, drilled in Upper Silesia. The

boring was undertaken to determine the relations of the coal beds in the Knurow royal mining district, and was conducted by the Schoenback division of the Prussian Royal Drilling Bureau. The locality of the drilling is 1.3 kilometers north of Czuchow village, in the Rybnik district. The drill used was a crude combination of the scoop, or wimble, chisel, and diamond-bit types, in conjunction with water rinsing. Operations were begun September 25, 1906, but the outfit was not installed until October 15.

The mouth of the hole was some 440 millimeters wide, exclusive of casing, but the diameter gradually diminished to 92 millimeters at a depth of 979.93 meters, which also marks the lower limit of casing. From this point down to 1,727.54 meters depth the diameter was 91 to 92 millimeters; down to 1,749 meters the diameter was 67.5 millimeters; down to 2,088 meters, the diameter was 50 millimeters; the remainder of the hole is 48 millimeters wide.

A total of 982 days was consumed in drilling, including 169 Sundays and holidays, and 119 days in accessory operations, as in drill repairing, etc., leaving 694 net working days. The maximum speed attained was a 24-hour record of 16.73 meters with the 91-millimeter diamond bit. Altogether 704½ carats of diamonds were consumed. The total cost of the drilling was 323,712 marks and 47 pfennig, or \$77,043.57, representing an average of 144.53 marks per meter, or \$1.04 per foot.

The list below shows the Prussian drillings exceeding 1,600 meters (5,250 feet) in depth, and the cost per meter in marks (the German mark is 23.8 cents):

	Depth Meters	Cost Per Meter Marks
Hoetmar	1,624.76	78.26
Schladebach	1,748.40	121.43
Ottweiler	1,803.36	81.53
Everswinkel	1,814.50	60.47
Paruschowitz V.	2,003.34	37.55
Schubin	2,149.45	68.51
Czuchow	2,239.72	144.53

來 來

Gate for the Top of a Coal Mine Shaft

By A. A. Steel*

All openings to shafts both at top and bottom should be guarded by substantial gates. These can be made to open and close automatically at the shaft bottom. The gate at the ground level should be opened only by hand and so arranged that it will not stay open except when the cage is at the landing.

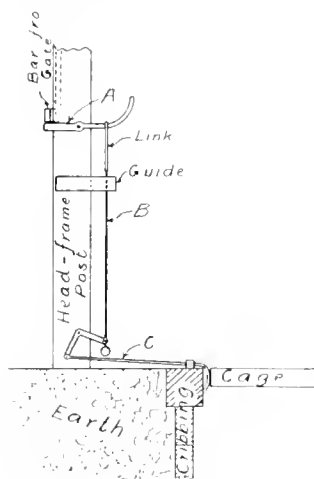

FIG. 1. LOCKING DEVICE FOR SAFETY GATE

The gate can be held open by other means in case it is necessary to get to the shaft while the cage is not at the landing, but the miners will not leave it open after ordinary use.

* Professor of Mining, University of Arkansas, Fayetteville.

Panther Creek Drainage Tunnel

Completion of an Important Part of a Drainage Scheme Begun Some Years Ago

The Lehigh Coal and Navigation Co. tunnel from Coal Port, near Mauch Chunk, to No. 2 shaft, Nesquehoning, was completed on February 5, 1912. The tunnel was started in July, 1906, and is 4.1 miles long. The engineering work was so perfect that both ends came together on the same level and line.

On January 1, 1911, it was decided to drive the drainage tunnel from both ends, a distance of 9,700 feet to connect. This was driven in 400 days, averaging 24¾ feet per day. In June, 1911, a distance of 459 feet was driven on No. 2 shaft end and 588 feet on Coal Port end, making a total of 1,047 feet per month; averaging 35 feet per day. The greatest distance driven on one end was in September, when 681 feet were driven on the Coal Port end, equaling 22.7 feet per day.

Through the completion of this tunnel to No. 2 shaft, Nesquehoning workings, the company will save considerable cost of pumping machinery, additional boilers, pump house, etc., and will prevent the mines from being drowned out. Besides, there will be a large reduction in fuel used for pumping purposes.

This tunnel will ultimately connect with the Lansford colliery, 7 miles from the portal. Four veins of coal were cut in driving the tunnel, the largest being 17 feet thick.

The drainage gangway is now being extended from No. 2 shaft, Nesquehoning, to Summit colliery, a distance of 1.5 miles. This will be driven west in a small leader 2 feet thick, between the Buck Mountain and Seven-Foot beds, for a distance of 5,000 feet, and will then tunnel north to Buck Mountain bed and continue in Buck Mountain bed to Summit colliery.

The Summit colliery is now being developed midway between No. 2 shaft, Nesquehoning colliery, and No. 6 shaft, Lansford colliery. At Summit colliery it is proposed to work three levels below the water level. The drainage gangway will connect with the lowest level and will not require any pumps, except for wash water for breaker, and the colliery cannot be drowned. It will save a large amount in fuel, pumping machinery, column pipes, steam pipes, and labor of operation and maintenance.

The work is being done under the supervision of Mr. W. G. Whildin, division superintendent, and Mr. W. B. Richards, mining engineer.

In November, 1907, Prof. H. H. Stoek wrote a descriptive article on this Panther Creek drainage tunnel for MINES AND MINERALS. As it will be comparatively new at this time, a part of his description is here reproduced and the sections with which it was illustrated are shown on pages 600 and 601.

"The methods of mining are those common to the anthracite region in thick steeply pitching seams, both as regards mining under cover and by stripping. As in all sections of the anthracite field, the matter of drainage is a very material item in the cost statement. It is estimated that for every ton of coal shipped to market by the Lehigh Coal and Navigation Co., 11 tons of water have been taken out of the mines. In common with the other sections of the anthracite region where the thick Mammoth and other seams outcrop, in unusually wet weather the quantity of water exceeds the pumping capacity, and very frequently the mines become flooded and work must be suspended until they are pumped out, thus causing added expense and also a decrease of tonnage during the flooded period.

"Workings in the western end of the Panther Creek Valley have drained through a water-level tunnel into the Little Schuylkill, but many of the workings are already much below this drainage level, and with increased depth the cost of pumping would gradually and steadily increase. Consequently it was decided by the management of the Lehigh Coal and Navigation Co. to drive one of the longest drainage tunnels yet contemplated and thus drain a considerable area by natural drainage. This tunnel starts

from the Lehigh River just above Mauch Chunk, as shown in Fig. 2 and will be driven through rock for a distance of about 7,500 feet until it intersects the Buck Mountain or B seam at the point X. From this point of intersection a drainage gangway will be driven westward, as shown in Fig. 2, until it meets a similar drainage gangway driven eastward from the old workings, thus giving a continuous drainage way about 13 miles long which will carry all the water above an elevation of 570 feet at the east end of the basin and 704 feet at the west end. By means of connecting tunnels and gangways a large territory of coal yet to be worked can be drained through this drainage gangway and tunnel, while the pumping lift from the lower workings will be materially reduced.

"The tunnel is driven with a grade of ¼ of 1 per cent, and its cross-section is shown in Fig. 1. For the first 300 feet the ground was soft and there was considerable difficulty in driving and in timbering, but after 300 feet was driven the solid red shale was struck and no timber was required. About 5,500 feet of red shale was driven through and about 2,000 feet of conglomerate before the Buck Mountain seam was encountered. Including the connecting tunnels and gangways there will be, all together, about 24,000 feet of rock tunnel and about 54,000 feet of gangway in the coal, making a total of nearly 14 miles."

Fig. 3 shows the level of the drainage gangway, and the height to which water will have to be pumped in the mines as at present developed. The cross-sections, A, B, C, D, E, and F, show the very great amount of coal which can be won above the water level of the new tunnel.

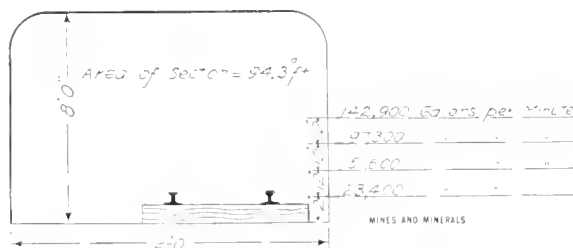

FIG. 1. CROSS-SECTION OF DRAINAGE TUNNEL

Although the tunnel is projected simply as a drainage proposition, it would be available for haulage purposes, should it prove advisable at any time to put a breaker at the mouth and haul the coal through the tunnel instead of hoisting it to the surface and carrying it overland. Since, however, the railroad would probably not allow any differential for this slightly decreased haul, it is not probable that this long underground haul will be resorted to.

The Lehigh Coal and Navigation Co. is the original Old Company of the anthracite fields, being a merger of the Lehigh Navigation Co. chartered in 1818 and the Lehigh Coal Co. The combination occurred April 21, 1820, and in that year 365 tons of coal were sent to Philadelphia.

Chilean Coal

To date, the mines of Chili have not been able to supply one-half the coal consumed in that country. The following table gives the analysis of samples of coal made by the technical department of the Chilean Government:

Constituents	Coal Taken From the Mines At			
	Concep- cion	Talca- huano	Arauco	Valdivia
Heat produced (Berthelot)....	7,692	5,641	7,581	6,068
Coke, per cent.	49.778	49.354	57.976	49.236
Coke, naturally.	Fine	Fine	Compact	Fine
Sulphur, per cent.	1.48	2.201	.005	.246
Volatile matter, per cent.	40.368	38.375	38.718	37.297
Fixed carbon, per cent.	45.116	44.625	55.702	47.518
Cinders, per cent.	4.662	4.129	2.274	1.718

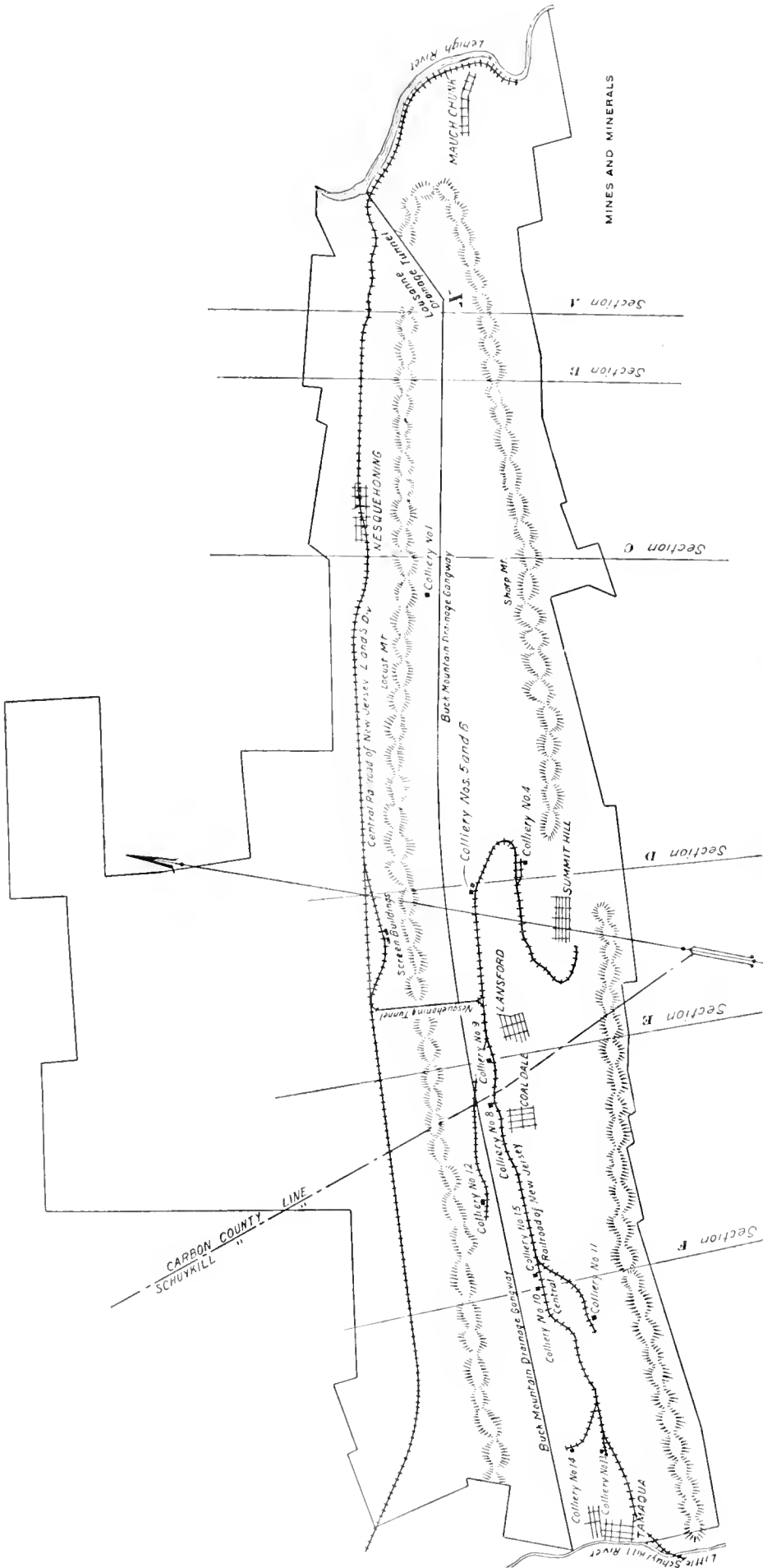

FIG. 2. MAP OF PANTHER CREEK REGION

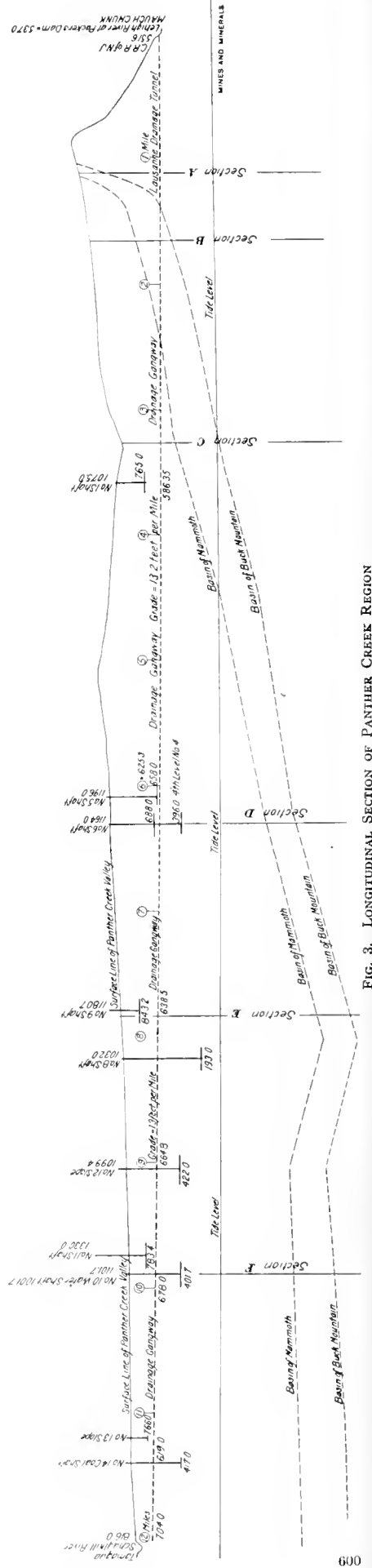

FIG. 3. LONGITUDINAL SECTION OF PANTHER CREEK REGION

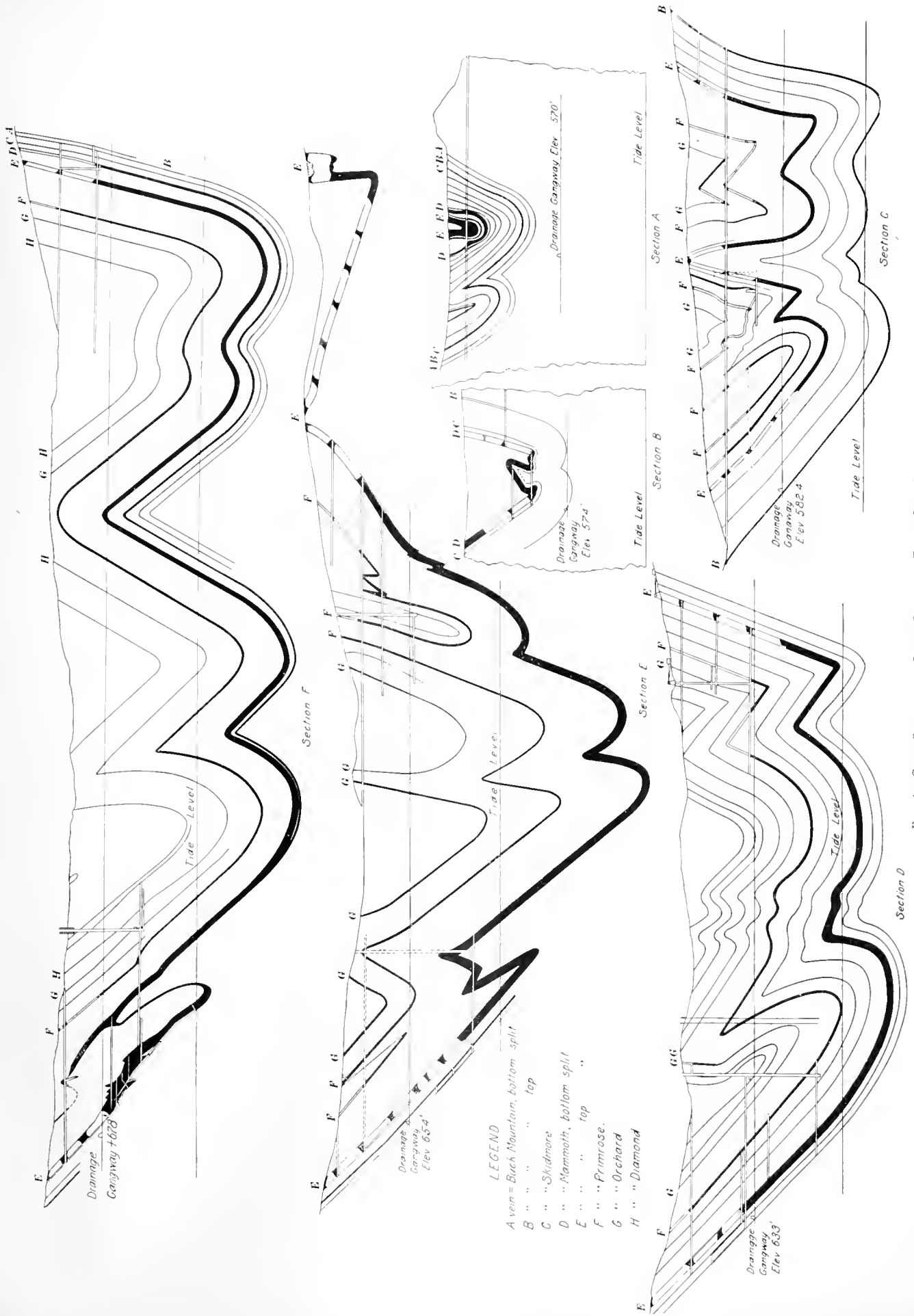

FIG. 4. CROSS-SECTIONS ON LINES SHOWN IN FIGS. 2, AND 3

Answers to Examination Questions

Questions From Mine Foremen's Examination, Pennsylvania Anthracite District, Pottsville, April, 1912

The following questions have either been recently answered in these columns or may be answered by quotations from the anthracite mine law:

QUES. 1.—What are the qualifications for a mine foreman and assistant mine foreman to fully fit them for the position, and what are their duties?

QUES. 2.—Quote the five sections of the law in regard to mine doors.

QUES. 3.—What is the mine law in regard to explosions? (a) Care of explosives? (b) How they shall be kept in the mines? (c) How should they be handled? (d) What are the rules governing their storage?

QUES. 4.—Who shall be in a mine evolving explosive gases?

QUES. 5.—Quote the law in regard to charging holes in coal and rock for blasting: (a) When a charge misses fire what are the provisions of the mine law? (b) What duty must the miner perform before and after firing?

QUES. 6.—What are the provisions of the law for removing bodies of gas?

QUES. 7.—What are the duties of a workman when gas becomes ignited in his place?

QUES. 8.—Having charge of a mine in which locked safety lamps are used, what precaution should you take before firing a shot?

QUES. 12.—What are the duties of a mine foreman, or his assistants, in case of injury to an employe. by an explosion of gas or powder, or by any cause, while said miners are at work in the mine?

QUES. 14.—Name the different mine gases, and where found, and their effect upon the human system.

QUES. 16.—Quote the law in regard to abandoned parts of a mine in operation.

QUES. 24.—How would you conduct the examination of a gaseous mine to ascertain its true condition?

QUES. 25.—What are the essential features of a safety lamp?

QUES. 26.—In the event of a severe explosion in a mine, what would be your first consideration and duty as a mine foreman?

QUES. 9.—(a) Having been placed in charge of a large mine, what precautions would you take to prevent mine fires? (b) If a fire should take place in the intake of your mine, what would you do?

ANS.—(a) The loading out of all fine stuff will tend to prevent the origin of gob fires and the systematic inspection of the old workings, as required by law, will lead to the detection of such fires at a stage when they may be quenched with comparative ease. Fires caused through the agency of electricity may be prevented by careful insulation; those due to ignition of pockets of gas, by the use of safety lamps; to handling of powder and oil, by observing the law as plainly set forth. However, unless all inflammable material is as far as possible removed from the mine, unless the utmost vigilance is exercised by the foreman and his assistants to see that the laws of the state as well as those dictated by common sense are carried out, fires will happen. The best preventive of fire is the education of the miner to the knowledge that slight carelessness on his part may lead not only to the loss of his own life but to that of many of his fellow workers as well.

(b) What a foreman could or should do will depend very largely upon where he happens to be when he, himself, discovers the fire. The question appears to indicate that he is supposed to be at the surface or at some other place where he can immediately take charge, a state of affairs that rarely happens. The first thing to do is to send warning to all men inside the fire zone to get out. The next step would be to slow down the fan and carry the air-current around the fire. Then dam the fire off entirely on the intake

side and fight it with water. The danger will not be so great to the men who fight the fire as on the return side. Much will depend upon conditions connected with the mine, so that no general rule can be laid down. To stop the fan and then reverse it would in some cases cause an explosion, but in case the men were in the air-current and it could not be short-circuited beyond the fire and before it reached the men, the reversal might be advisable if the mine was not gassy in that split where the fire occurred. The superintendent should then be notified, who will take the necessary steps, should his judgment decide, to call upon the district inspector, the rescue crews of his own and neighboring mines, and the United States Bureau of Mines. In the meantime word should be sent by telephone or by word of mouth to all men inside to come out at once. It must be assumed that a large percentage of the men upon first smelling smoke or noticing the reversal of the current will begin to come out, notifying their fellows on the way, and the fire must be treated so as to preserve the lives of the greatest number. While it is probably true that the reversal of the current in a gaseous mine might cause the death of a greater or lesser number of lives through explosions of gas, yet there is a chance that such explosions may not take place. The possibility of an explosion should not be considered in the face of the absolute certainty that all men within reach of the current will be suffocated unless the fan is reversed.

QUES. 10.—What is the object of the following pillars: A barrier pillar; reservation pillar; chain pillar? Explain fully.

ANS.—A barrier is a large pillar left between the workings of adjoining mines to prevent the entrance of water or gas from one mine to the other, or to prevent a squeeze or other disturbance in one set of workings being carried over into the other. A reservation pillar is left to support the pillar under certain buildings, or is a block of coal not owned by the operating company, or is sometimes taken to mean the shaft pillar left to insure the verticality of the shaft and guides and head-frame. A chain pillar is one between the faces of the chambers on one lift and the air-course of the lift above. It bears the same relation to and is used for the same purpose as the barrier pillar between two adjacent mines.

QUES. 11.—State fully what you would consider a safe thickness of strata to work an overlying seam 3 feet thick; the underlying seam is 10 feet thick, worked to the land line and robbed back; dip 40 degrees.

ANS.—If robbing is still in progress in the lower seam it would not be safe to work the upper one because of the danger of roof falls and sudden and frequent outbursts of gas due to settling of the strata between the two beds. While it is true that there is a certain indefinite thickness of strata that will prevent disturbances in the lower bed being carried to the upper one, yet such thickness is not common in the anthracite region. If, however, robbing has ceased in the lower bed, the upper may be worked as if it was a highly inclined thin seam, very gaseous, with bad roof and floor, cut up with small faults of dislocation, the latter due to the uneven breaking off of the rocks between the two beds. The question is then the economic one of whether the coal can be sold at a profit after paying for the extra cost of timbering and tracklaying caused by the bad roof and irregular floor.

QUES. 13.—What size gangway would you consider the most practical in the following veins: Mammoth seam, 25 feet thick; seven-foot seam, 10 feet thick; Buck Mountain seam, 12 feet thick. Give spread, height, and what size timber you would use in each seam.

ANS.—Dimensions 12 feet at floor \times 10 feet at roof \times 7 feet high. The collar should be 10 in. \times 12 in. and the legs about 10 in. \times 10 in., but if round sticks are used they might all be 10 inches in diameter. The batter should not be over 1 inch in 7 inches.

QUES. 15.—What instruments are necessary for a mine foreman to comply with the law? Explain fully the purpose of each.

ANS.—The only provision of the mine law calling for the use of instruments is the one demanding that the mine foreman shall see that air to the amount of not less than 200 cubic feet per minute per employe is circulated through the workings. To ascertain the

amount of air in circulation, a steel or "metallic" tape is necessary to measure the height and breadth of the gangway that its area may be determined; a watch must be used to note the time during which the vanes of the anemometer are in motion, usually an even number of minutes, and an anemometer must be employed to measure the velocity of the air. This latter instrument consists of a series of vanes on an axis, so arranged that the number of revolutions made by them may be read off from one or more dials. A simple multiplication gives the total number of cubic feet of air passing per minute. This quantity, divided by the number of men in the mine, must equal or be greater than 200, if the law is properly complied with.

QUES. 17.—In gaseous mines it is customary at times to change the air-current. State the purpose of this. What should be the duty of the foreman and his assistants after changing the air-current? Explain fully.

Ans.—The air-current is sometimes changed from its usual route and conveyed through the old workings to remove accumulations of gas. This would, naturally, be done only when all of the men are out of the mine. After the current is returned to its usual route a very careful inspection should be made of all working places to see that no dangerous bodies of gas have accumulated and the roof should be examined to see if it has been loosened, as is sometimes the case, through the changes in temperature and humidity brought about by changing the current.

QUES. 18.—For the prevention of accidents what would you consider a safe and practical method for driving cross-headings between the breasts, one breast being ahead of the other?

Ans.—If all precautions are taken, it can make no difference from which side the cross-heading is started. It would appear safer to start at the right distance in the long room and work toward the short one, for the reason that the miners would be such a short distance (the thickness of the pillar) from the others that signaling when about to fire is possible. Otherwise, it would be necessary to go down to the gangway and possibly up the next room to give warning.

QUES. 19.—There are eight splits of air in a mine, the maximum number of persons are employed in each split, the minimum quantity of air passing. State number of persons working in the mine, also the area of the main intake; the velocity of the air is 450 feet per minute.

Ans.—Seventy-five men are allowed in each split and must each have 200 cubic feet of air a minute. The volume of the current is then $8 \times 75 \times 200 = 120,000$ cubic feet. If the velocity is 450 feet per minute, the area of the intake will be $\frac{120,000}{450} = 266.66$ square feet.

QUES. 20.—In a mine ventilated by one continuous current of air what would be the effect of splitting the current into several splits? Explain how it can be done and why such a result is obtained.

Ans.—Splitting may be done by means of doors and regulators at the foot of the downcast shaft and at other points in the mine where it is desired to improve the ventilation. The advantages are that a larger quantity of air is moved by the same power, because the decreased velocity reduces the friction; the entire circulation is divided into districts and is more easily controlled, it being possible to increase or decrease the supply to any one section of the mine should the need arise; purer air is supplied to the face, since the return from each district is conveyed directly to the main return instead of circulating through the workings; as the districts are isolated, the effects of an explosion in one are not so apt to be communicated to another; and as a large volume of air is conducted through the workings at a moderate speed, the danger due to high velocity of the air-current in gaseous mines is much diminished.

QUES. 21.—What precautionary measures would you adopt to prevent loss of life in mines where sudden outbursts of gas occur?

Ans.—Ample ventilating currents should be provided and the mine should be worked entirely with safety lamps. In addition

the gas may in a measure be reduced in amount by driving bore holes from the surface through which the gas may escape, or if the gas comes from the roof or the floor, drill holes may be placed up or down to tap the gas and thus relieve the heavy pressure on the roof, which causes falls, and on the floor, which causes heaves. Naturally, the inspection on the part of the fire bosses should be extremely thorough.

QUES. 22.—State your experience, if any, with mine fires, and what precautionary measures would you adopt with the view of minimizing the causes leading to their occurrence?

Ans.—See answer to Ques. 9 (a).

QUES. 23.—Give your ideas relative to the proper maintenance of traveling ways and gangways:

Ans.—The timbering should be of good quality, of sufficient size, and set in a workmanlike manner, and in such a way to best resist the pressure coming upon it. Timbering should be regularly inspected, and all unsound or cracked pieces promptly replaced. The roads should be kept clean to diminish the friction on the rolling stock, and standing water should not be allowed, as it rots the ties and by making the roadbed soft destroys the alinement of the track; consequently all ditches should be kept open and free from rubbish. Ample space should be allowed on one side of the track for the passage of men, the rails and ties should be as large as it is economically possible to have them to ensure stability in the roadbed. If electric haulage is used, the bonding should be done with the greatest care to prevent drop and loss of current; also, all overhead trolley wires should be placed in troughs of wood to diminish the liability of a man coming in contact with them, and main feed-wires should be covered with heavy insulation. All air-courses should be inspected as regularly as the main gangways and should be kept in as good repair.

QUES. 27.—Give your method of working a gangway, chutes, headings, and eight breasts, in a vein pitching 60 degrees, 6 feet thick and very gaseous.

Ans.—The gangway and air-course should be driven in the usual way, with brattices to convey the air to the face beyond the last cross-cut. Chambers should be opened on the double-chute plan, sides of chutes formed of upright posts backed with timber and made as air-tight as possible that the air may be carried close to the face. Locked safety lamps should be used to the exclusion of open lights.

QUES. 28.—The Mammoth and Skidmore seams run east and west from the bottom of a shaft a distance of 5,000 feet. State fully how you would proceed to work both seams economically and to win most coal?

Ans.—The Mammoth bed being over the Skidmore, the rooms and pillars in the latter should be centered directly under those of the former and be of the same area, further, every tenth pillar in both beds should be left as a binder to be removed when robbing back.

QUES. 29.—How can you tell whether or not any obstruction is in the air-course, which you have not examined?

Ans.—Assuming that the fan is making the normal number of revolutions, an obstruction in the air-course will be indicated by the lessened velocity of the air in the main gangway as determined by the anemometer or by observation. Also, should the reading of the water gauge be greater than usual, an obstruction in the air-course is indicated.

QUES. 30.—If the main ditch in a mine is 24 inches wide, 18 inches deep, and running full of water at a uniform velocity of 5 feet per second, how many gallons of water is the mine producing in 24 hours?

Ans.—A ditch 24 in. \times 18 in. has a cross-section of 432 square inches. At a velocity of 5 feet per second, the volume will be $432 \times 5 = 2,160$ cubic inches. The quantity per 24 hours will, therefore, be $2,160 \times 60 \times 24 = 3,110,400$ cubic inches. As there are 231 cubic inches in a gallon, the number of gallons is obtained by dividing 3,110,400 by 231, which equals 13,464.9 gallons.

QUES. 31.—A pipe line in the slope of a mine has an area of 180 square inches, and is 3,000 feet long; the slope is on a grade of

1 in 10 feet; what is the pressure per square inch at the bottom of the pipe when it is full of water?

ANS.—Assuming that the rise is 1 foot for each 10 feet in length of the slope, the total rise, which equals the head of water, is $3,000 \div 10 = 300$ feet. As a column of water 1 foot high and with a cross-section of 1 square inch weighs .434 pound, the total pressure upon the surface in question will be $180 \times 300 \times .434 = 23,436$ pounds.

QUES. 32.—What is a coal mine?

ANS.—According to the law a coal mine is taken to include the shafts, slope, drifts, or inclined planes connected with the excavations or workings in a coal bed or beds, which workings are ventilated by one general air-current, used as a whole or in splits, and connected by one general system of mine railroads, over which coal may be delivered to one or more parts outside the mine. In many states the word mine includes the surface plant, such as the head-frame, boiler house, and other buildings immediately connected with the mining and preparation of the coal, and in some few states, the entire property of a coal company is comprised within the meaning of the word mine.

采 采

Mining Societies

E. B. Day, secretary, announces that the West Virginia Coal Mining Institute will continue to hold two meetings a year. The next meeting will be held at Charleston, W. Va., in June, the exact date to be incorporated in a later bulletin.

Two student societies that are affiliated with the American Institute of Mining Engineers were unfortunately left off the list in April MINES AND MINERALS. They are:

The Pick and Shovel Club, of the Case School of Applied Science, Cleveland, Ohio. President, L. B. Riddle; secretary, S. C. Stillwagon.

Colorado School of Mines Scientific Society, Golden, Colo. President, Alan Kissock; secretary, George Wilfley.

CANADIAN MINING INSTITUTE MEETING

The fourteenth annual meeting of the Canadian Mining Institute held in Toronto, March 6, 7, and 8, was attended by about 300 members and guests. To the local committee composed of W. F. Ferrier, J. B. Tyrrell, H. Mortimer-Lamb and his assistant, the delegation from the United States extend assurances of their most distinguished consideration for a very enjoyable occasion. The editor of the *Canadian Mining Engineer*, J. C. Murray, also assisted in entertaining the visitors, particularly those of his own persuasion.

Wednesday morning was devoted to Dr. Frank D. Adams' Presidential Address and to Canadian Mineral Statistics. Papers were read during the day by Messrs. C. H. Clapp, Ottawa; D. D. Cairnes, Ottawa; J. J. Penhale, Sherbrooke; H. E. Kramm, Ithaca, N. Y.; Victor G. Hills, Moose River Gold Mines, N. S. In the evening Dr. W. H. Tolman, Director of the American Museum of Safety, delivered an illustrated lecture on "Accident Prevention, or the Conservation of Human Life." Doctor Tolman's lecture aroused considerable interest which, it is believed, will lead to the establishment of a "Museum of Safety" in Canada. On Thursday papers were presented by Robert H. Richards, Boston, Mass.; W. R. Ingalls, New York; H. W. Hardinge, New York; David H. Browne, Copper Cliff; E. W. Brown, Bridgewater, Nova Scotia; T. A. Rickard, London, England; Dr. A. A. Barlow, Montreal; R. E. Hore, Houghton, Mich.; J. B. Tyrrell, Toronto; Chas. A. O'Connell and Earl Reinhardt, Cobalt. Among the most important papers presented at this time, because of its relation to the preservation of life, was that of Dr. Chas. H. Hair, of Cobalt, who made a plea for sanitation in the new mining camps of Canada in order to guard against disease and epidemics such as have troubled Cobalt in the past.

Thursday noon Prof. J. F. Kemp, President of the American

Institute of Mining Engineers, delivered an excellent address on "Technical Education," before the Empire Club of Toronto. His delivery and happy expression compared favorably with the best speakers at the meeting. The "Smoker" in the evening was opened by rending in twain the Canadian Mining Institute's anthem "Drill Ye Terriers Drill." The preceptor tossed the "chune" so high it went out the ventilator and consequently when the words "We work all day without sugar in our tay" were reached the promoters in the hotel lobby ran into the street to see the dog fight. Colonel Penhale, chairman of the session, could not be induced to repeat the anthem, but to show that there was some harmony in Toronto called on the University of Toronto Glee Club. These youngsters were the musical hit of the evening, although the Institute did very well with "Oh! Canada," and the "Star Spangled Banner." Professor Kemp illustrated how he reached the north pole. Editor Rickard and Colonel Hay recited poetry, something that sounded like home-made poetry. Mr. Birkenbine rediscovered a number of minerals, among them Israelite. Chairman Penhale introduced a man by the name of Smith who was once a miner but now a politician and prestidigitator. He stuck E. W. Parker's dollar bill in a lemon, which lemonaded its up keep. Several other forms of amusement were furnished although much to the writer's regret the bird song, "Allouette, gentille allouette, allouette je te plumerai," was omitted. When in session the members of the Institute attend strictly to business, and when at play, to good clean fun.

On Friday papers were read by Frank C. Loring, Toronto; J. Park Channing, New York; Prof. H. H. Stoek, Urbana, Ill.; F. L. Garrison, Philadelphia; F. H. Sexton, Halifax, N. S.; H. G. Carmichael, Sudbury; Dr. C. K. Leith, Madison, Wis.; J. B. Tyrrell, Toronto; Dr. J. F. Kemp, New York; Dr. A. P. Coleman, Toronto; W. Lindgren and E. W. Parker, Washington, D. C.

Announcement was made that Dr. A. E. Barlow, of Montreal, had been elected President of the Institute for the ensuing year.

Those who registered from England, were Bernard H. Huges, London; George E. Leighton, Sheffield; F. B. Archbold, Cambone; and T. A. Rickard, London. Those who registered from British Columbia were C. H. Dick and W. J. Elmendorf, Victoria; E. Jacobs, R. R. Hedley, Vancouver; S. S. Fowler, Nelson. There were probably others. There are 96 members of the Institute in the United States, of whom a number were present, but only a partial list can be given owing to late registration. Prof. H. H. Stoek, Urbana, Ill.; Prof. H. Ries and H. E. Kramm, Ithaca, N. Y.; Prof. R. H. Richards and W. E. C. Eustis, Boston; Charles Mentzel, Denver; Henry Kehoe, Spokane; R. E. Hore, Houghton; William Kelley, Vulean, Mich.; E. J. Carlyle, Prescott, Arizona; R. Van A. Norris, Wilkes-Barre; John Birkenbine and F. L. Garrison, Philadelphia; Prof. J. F. Kemp, A. S. Dwight, Dr. W. H. Tolman, J. Park Channing, N. V. Hansell, W. R. Ingalls, H. W. Hardinge, New York City; G. F. Vasey, and E. B. Wilson, Scranton.

Nova Scotia was represented by F. H. Sexton, Halifax, and V. G. Hills, Moose River mines. Ontario and Quebec had large delegations present. Quite a number of delegates went from Toronto to Porcupine after the meeting.

On Friday evening the banquet was held in the ball room of the King Edward hotel. In another room the lady friends and relatives of the delegates held their banquet. After coffee they were escorted to seats in the banquet hall where they could listen to the speeches. The officers of the Canadian Mining Institute are broad-minded men and will not therefore be peeved by the following suggestions: First, that the important toast "The Press" be removed from the last number of the program and inserted in about the center. Second, that some of the members in the United States assemble their families or lodge friends at intervals for the purpose of convincing said families or lodge friends that they, the party of the first part, are able to deliver an address in public.

ORE MINING AND METALLURGY

Mineral District of Rayon

A Silver Region of Mexico That Has Produced Rich Ore,
But of Which Little Is Known

The following article is by H. D. Boddington, D. Sc., Metallurgical Chemist of El Paso, Tex. It originally appeared in the *Mexican Mining Journal*, February, 1912, and is published by permission. It deals with a country that has hardly been investigated.

The mineral region of Rayon is situated in the state of Chihuahua, Mexico, in the heart of that section of the Sierra Madre Mountains, which divides Sonora from Chihuahua. The elevation varies from 4,000 to 6,500 feet, and the climate is all that can be desired. Rayon district is said to be the wealthiest in the state, and to possess some of the greatest and best mines in the Republic. Ocampo, the principal town, is about 30 hours muleback ride from the railroad. This is a thriving center and in addition to being the seat of Federal authority it is also headquarters for quite a considerable mining community. The Sierra Mining Co. and the Waterson Mining Co., Ltd., carry on large operations in the locality. South of Ocampo about 20 hours ride on mules is the Mineral de Uruachic. The Hot Springs on the trail to this village are shown in Fig. 1. Until a few years ago this was the county seat of the district. It then boasted of a state assay office and other federal privileges. Today much of its mining activity has disappeared, in consequence of which its former glory has vanished. For some years it has been under a cloud, owing very largely to its isolation and remoteness from the railroads.

The geological features of the municipality are interesting but complex. The ore is mainly deposited along fractures in intrusive bodies of diabase. The veins themselves are of altered andesite, and porphyritic in character. The principal mineral is argentite, with some stephanite, dyscrasite, tetrahedrite, and occasionally native silver. The gangue is silicious, and contains varying proportions of iron, lime, and lead sulphides. Most of the ore at present is dressed in primitive hand jigs, and then treated by the "Hypo" process in a Mexican lixiviation mill at Nueva Union.

This is a costly and extravagant process. The products from the jigs average 100 ounces of silver to the ton. The run of extraction is from 60 to 70 ounces per ton, so that 30 ounces and upwards are left in the "tailing." Years ago the owners

took the precaution of impounding these, and today the "dumps" would be a valuable asset were it not that the extraction costs amount to more than the silver in them.

Uruachic has produced phenomenally rich ore, but like many other places, it has reached the condition where low and moderate grade ore must be treated. Most of the ore is base and not amenable to ordinary methods of extraction. Quite a large quantity exists in the camp carrying from \$10 to \$15 per ton in silver. Nothing can be done with this until an economical method is devised which will make it profitable to treat such ore. The difficulty is a metallurgical one, which the camp has to work out in order to hold its own with surrounding districts.

At the San Jose mine is developed by an incline shaft to a depth of 300 feet, the vein which is known locally as "calichi" and is from 4 to 14 feet wide. Drifts are run on the vein in both directions from the shaft. The ore is treated first by washing and hand jigs, and subsequently by the "Hypo" process in the mill referred to.

The Alacran mine is developed to a depth of 600 feet by a vertical shaft, from which are levels and extensive workings. Two veins course through the property. The "La Veta Negra" contains a black complex sulphide ore, consisting largely of blende. It is an impossible ore for reduction so far as the camp is concerned. The "Veta Blanca" is much more amenable to treatment, and is worked. The ore from it is sorted carefully, the first class, assaying from 400 to 600 ounces per ton in silver, is shipped to Chihuahua, while the second class, with from 100 to 200 ounces per ton in silver, is treated in the local mill.

The San Martin mine belongs to what is known as the "clavo" class. A large quantity of high-grade ore has been extracted from one of these "clavos." Its present owners have run a tunnel 1,700 feet long in order to get under the old "workings." They have also erected a 50-ton concentrating mill, and a 25-ton reverberatory furnace for treating the ore from the mine.

The Las Animas mine shown in Fig. 2 has been developed to a depth of 900 feet, and has produced a large amount of high-grade ore. The vein is of andesite carrying argentite and tetrahedrite, with some gold. It is said that the ore averaged 200 to 250 ounces of silver per ton. Work was stopped on account of the water. Some thousands of tons of ore are on the dump, running 30 ounces of silver per ton. Unfortunately the high percentage of blende make it difficult to treat.

The Santa Rosa mine enjoys quite a reputation, owing to the fact that many years ago the Mexican owner in driving an

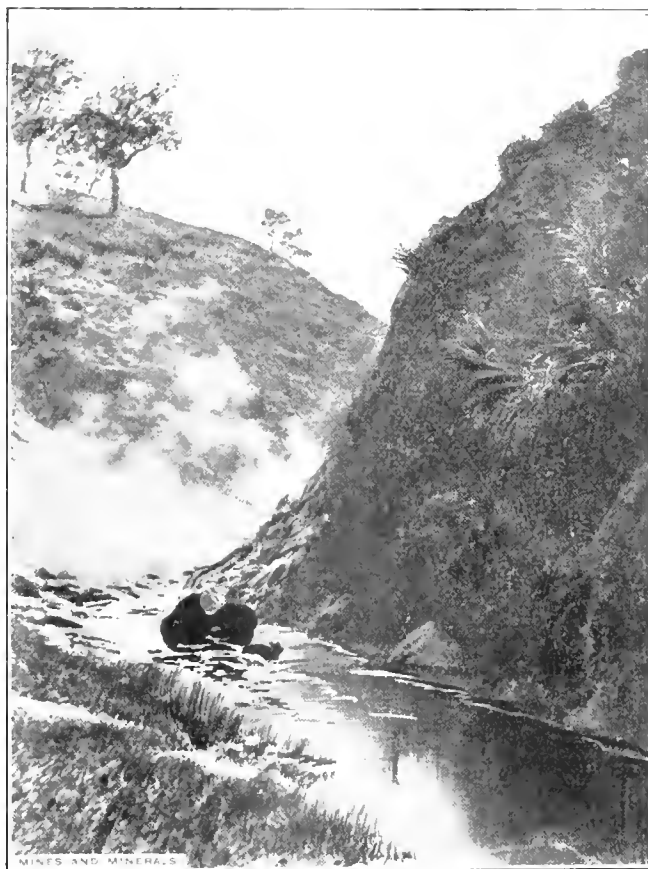

FIG. 1. HOT SPRINGS ON TRAIL TO URUACHIC

adit encountered a body of ore from which he extracted 1,500,000 ounces of silver in a distance of 50 meters. The ore body then faulted, and the owner after drifting and sinking in all directions, after a time got discouraged and abandoned the property.

South of Uruachic are to be found other old mines which have produced large quantities of high-grade ore. Notable

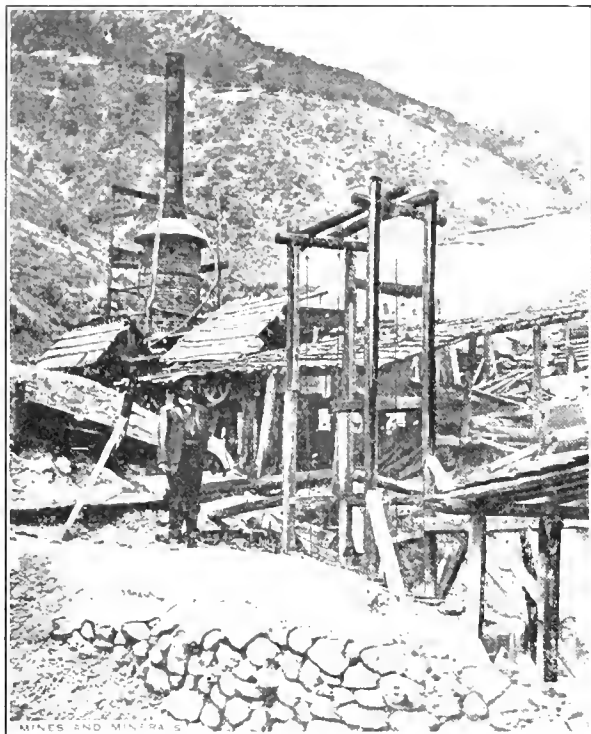

FIG. 2. LAS ANIMAS MINE AND DUMP

among these are the Los Hilos, and the Las Bolas, which, it is said, yielded ore which would carry 48 per cent. silver. During the whole of my sojourn in the district I never saw ore so valuable.

Between the town and the Rio Oteros there are several copper and galena prospects, which impressed me favorably, but the lack of cheap transportation would seriously handicap their development.

Roads are an absolute necessity in this district, and the State Government should construct a wagon road between the town and the railroad, compelling the municipalities through which it passes to keep it in repair. The mineralized area covered by the municipality would, I think, repay good prospecting. At present there are many small prospects, the owners of which can do nothing owing to the high cost of marketing their ores. If facilities for this existed I think that Uruachic would regain some of its former prestige. The writer is informed that a company headed by Mr. F. M. Gallagher, of Santa Barbara, Cal., has organized for the construction of a hydro-electric plant on the Rio Otero. Preliminary plans and specifications have already been drawn for a plant capable of generating 2,000 horsepower. This will be a great boon for the municipality and should do much to aid the development of the district.

One cannot travel far from Uruachic in any direction without coming across some camp in which important mining activities are in evidence. Candemena and Ocampo, Yoquivo, Aruchuno, Concheno are but a few hours distant.

來 來

The imports of talc in 1910 were 8,378 tons, at an average price of \$12.71. The import duty on ground and manufactured talc is 35 per cent. A modified pneumatic process for securing the most uniform fine grades of talc flour has been introduced in a Massachusetts mill.

Necessary Amendments to Mineral Laws

In an address at the 21st anniversary of the Michigan School of Mines, Houghton, Mich., George Otis Smith, Director of the United States Geological Survey, talked on "The Mining Industry and the Public Lands" and "The Necessary Amendments to the Mineral Laws." Abstracts from the address follow.

The objects to be sought by amendment of the public land laws are, first, purposeful and economical development of resources for which there is present demand, with retention of such control as may insure against unnecessary waste or excessive charges to the consumer; and second, the reservation of title in the people of all resources the utilization of which is conjectural, or the need of which at least is not immediate.

Under the withdrawal act of June 25, 1910, classification is made possible in advance of disposition, and disposition can be postponed to await needed legislation. Land classification is first of all the determination of the best use to which each particular portion of the public domain can be put, and by the organic act of March 3, 1879, this duty was specifically imposed upon the Director of the Geological Survey.

The question of amendment of the present laws relating to the disposition of coal, oil, gas, and phosphate deposits on the public domain is recognized as fairly before the public by the specific mention of these minerals in the withdrawal act.

The coal-land law is unquestionably the most satisfactory of the present mineral land laws, and in the administration of this law the purpose is not only to base the appraisal price upon the quantity and quality of the coal present, but also to make the selling price approach as nearly as possible the present purchase of a royalty under a leasehold. Thereby it is intended to permit purchase for immediate development and at the same time to prevent, or at least discourage, purchase for long-time investment or for monopolization. An ideal adjustment of the values is well nigh unattainable for most coal lands, and on this account a strong argument may be made for support of the lease over the sale system. The present coal-land law, however, has one serious defect, which should be remedied if a leasing law is not enacted. The restriction of area that may legally be acquired to a maximum of 160 acres for an individual and 640 acres for an association is not in accord with good mining practice. The fixed charges on the cost of a modern coal mine, provided with the up-to-date equipment necessary to conserve life and property and to assure maximum recovery, are too high to be assessed against the tonnage of so limited a tract, especially if the coal seam is of moderate thickness.

The most urgent need of legislation for the disposition of mineral deposits is in the case of oil and gas. It is most apparent that the placer law, which is none too well adapted to meet modern conditions in mining placer gold, is wholly inadequate as a method of dealing with public oil lands, inasmuch as the discovery of oil is a late stage in the exploration and development of the land claimed under the law. Thus, large expenditures, extending over several months, if not years, are necessary before any right is acquired against the government, and during all this time there is lacking any legal protection of the oil prospector against unscrupulous claimants or competitors better backed by capital.

The present uncertainty whether the phosphate rock of the public land should be entered under the lode law or under the placer law is conclusive evidence of the need of legislation. As a matter of fact, neither of these laws is more applicable to the acquisition of beds of phosphate-bearing limestone than it would be to that of coal beds.

The law of the apex has proved more productive of expensive litigation than of economical mining. In many of the more recently established and more progressive mining districts this statute has been made inoperative by either common agreement or compromise between adjoining owners. Its repeal could not affect established equities under patents already granted, but would render possible more certain property rights in large mining districts as yet undiscovered.

The Blast Roasting of Galena

Results of Experiments in Roasting Galena and Galena Mixed With Lime, Gypsum, Etc.

The following is abstracted from C. O. Bannister's paper in Bulletin No. 89 of the Institution of Mining and Metallurgy, London. After an interesting introduction which includes the probable reactions advanced by Huntington-Heberlein and others, Mr. Bannister furnishes the results of his experiments when roasting galena alone and when mixed with lime, limestone, gypsum, etc.:

The object of the first series of experiments was to obtain a record of the thermal and chemical changes which take place during the roasting of galena in admixture with lime and other compounds. A sample of galena, having the following analysis, was used: *Pb*, 78.56; *S*, 11.79; *SiO₂*, 2.20; *Fe*, 2.24; *Zn*, 1.98.

(a) *Original Huntington-Heberlein Process*.—Preliminary experiments with lime were carried out on roasting dishes in a muffle furnace, and the occurrence of the glowing phenomenon in the presence of lime, as described by Hutchins, was confirmed, but more interesting reactions were also noted.

Instead of a single glow taking place at a dull red heat, the following changes were noticed on roasting a charge containing 80 per cent. galena and 20 per cent. quicklime:

At a low temperature sulphur flames covered the top of the charge, and sulphur dioxide was undoubtedly evolved.

As the temperature rose to dull redness, a surface reaction commenced at one part of the charge, and a distinct glow slowly made its way over the whole surface. After this reaction had finished, the whole mass became comparatively dull, and on continuing to raise the temperature, to red heat, an exactly similar reaction was repeated, the whole mass slowly glowing all over, and then again becoming dull.

In order to obtain a record of the exact temperatures of these heat evolutions, a charge was placed in a roasting dish, and just under the surface a thermo couple junction was placed, connected through a cold junction and resistance box to a mirror galvanometer. The muffle was then slowly heated by gas, and temperature readings taken every half minute. The results are plotted in the curve *AB*, Fig. 1, the curve *CD* showing the rate of heating the muffle.

It will be noticed, on examining the curve, that between 180° C. and 260° C. a small evolution of heat is recorded; this is due to burning sulphur, then the temperature rises steadily up to 560° C. when a considerable evolution of heat takes place, corresponding to the first glow noticed. The rapid rise in temperature slacks off after 730° C., and at 745° C. a second slight evolution of heat takes place, although there was no observable brightening of the charge. At about 800° C. a considerable evolution of heat takes place, the temperature of the charge rising rapidly to over 900° C.; this large evolution of heat is found to correspond in temperature to the second glow noticed during the roasting of the mixture.

These thermal reactions were confirmed many times, and although only one curve is given, many were made, and several confirmatory curves also for each mixture studied. The temperatures at which the reactions take place vary from time to time, but the curves given are typical. As a result of this experiment it was decided to test thermally Huntington and Heberlein's original theory, and for this purpose a mixture containing 80 per cent. galena and 20 per cent. lime was heated to 700° C. and then allowed to cool, the temperature being taken every half minute during the cooling. The figures obtained are plotted in curve *EF*, Fig. 1.

It will be noticed that these values give practically a straight line, and that there is no oxidizing decomposition taking place

at 500° C. with evolution of heat and sulphurous acid, as stated by Huntington and Heberlein.

The complete ultimate analysis of the partially roasted material presents difficulties, as the mixture may possibly contain lead sulphide, lead sulphate, calcium oxide, calcium peroxide, and calcium plumbate.

Experiments were carried out to determine the changes in weight taking place during different stages of the roast, and in the case of the mixture containing 80 per cent. galena and 20 per cent. lime, the following results were obtained:

	Experiment	
	No. 1 Per Cent.	No. 2 Per Cent.
On heating up to temperature of first glow, loss of70	.80
On heating through first glow, gross gain of	5.55	5.72
On heating through second glow, gross gain of	13.87	13.10

It is found that repeated experiments do not give a constant increase in weight at the periods tested, the increase depending

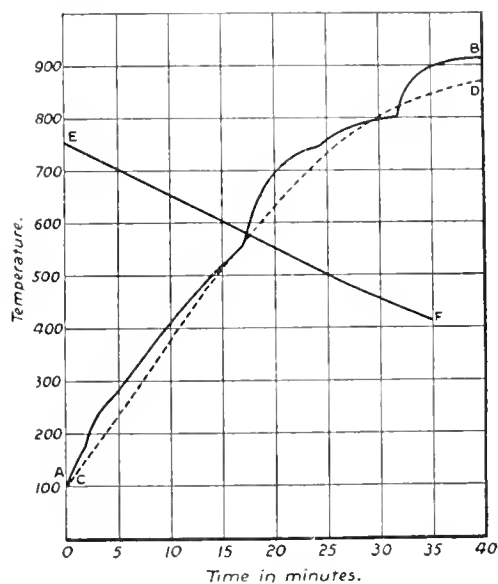

FIG. 1. GALENA-LIME ROAST

to a certain extent on the state of division of the material, the thickness of the layer in the roasting dish, and the rapidity of heating.

Corresponding to the changes in weight noted, there were important changes in the amount of free lime left in the mass; the following figures were obtained by titration with oxalic acid, and although not given as exactly accurate, are a fairly good approximation to the truth:

		Experiment	
		No. 1 Per Cent.	No. 2 Per Cent.
Original material	Free lime	18	21.0
After first glow	Free lime	13	16.0
After second glow	Free lime	3	6.2

Allowing for the increase in weight of the roasted material, these figures show that in experiment No. 1, during the first glow 4.5 of the original 18 per cent. of free lime has been changed to some compound without an alkaline reaction, and that during the second glow 14.6 of the original 18 per cent. has been similarly changed. In the case of experiment No. 2, dur-

ing the first glow 4.4 of the 21 per cent. and during the second glow 14.1 of the 21 per cent. has been similarly changed. The compound thus formed was proved to be calcium sulphate, by extraction with water and examination of the dissolved matter.

The products of the roast were also examined for calcium sulphide, as this compound had been supposed to be formed by Carmichael and Bradford.

The method of detection adopted was to test the mixture with dilute acetic acid, which liberates sulphuretted hydrogen from calcium sulphide, but not from lead sulphide. Neither after the first, nor after the second glow, was any trace of calcium sulphide found.

As the formation of peroxides had been mentioned by Huntington and Heberlein and others as possibly playing some part in the reactions, tests were made and distinct quantities of peroxides were discovered, both after the first glow and after the second glow. The test used consisted in treating the material with dilute sulphuric acid and potassium bichromate, then adding ether, and shaking; the distinct blue color produced in the ether indicated the presence of peroxides. It was found impossible to use the most satisfactory method for the determination of peroxides by treatment with hydrochloric acid and determination of the chlorine evolved, owing to the presence of small quantities of undecomposed sulphides which interfere with the method. Some idea as to the amount of peroxide present was obtained, however, by determining the oxidizing power of the material on ferrous sulphate, the figures obtained showing .08 per cent. PbO_2 after the first glow, and .20 per cent. after the second glow. Experiments showed that calcium peroxide was not present, for, on treating with water, the solution gave no peroxide reaction, but the residue did.

A number of experiments were made to determine the mode of formation of the peroxide. These consisted in heating to various temperatures lead oxide alone, lime alone, and mixtures of lead oxide and lime. After allowing the tests to cool and examining them for peroxides, it was found that lead oxide and the lead-oxide-lime mixture gave about an equal indication of peroxide when heated to temperatures up to 850° C. It was found that the lime also gave a peroxide reaction, but this may have been due to a slight contamination by barium. From these results it was concluded that lead peroxide was formed during the cooling of the roasted mass, and that the quantity was not influenced by the presence of lime.

By determining the amount of free lime, total sulphur, sulphide sulphur, lead, and insoluble matter, in the roasted material, it was possible to calculate approximately the ultimate composition. By this means the following results were obtained:

ORIGINAL GALENA-LIME MIXTURE	
Lead sulphide.....	70.4
Lime.....	20.9
Silica.....	1.7
Undetermined (Fe, Zn, etc.).....	7.0

ROASTED GALENA-LIME MIXTURE AFTER FIRST GLOW	
Lead sulphide.....	25.3
Lead sulphate.....	7.3
Lead oxide.....	28.7
Lime.....	16.0
Calcium sulphate.....	10.4
Silica.....	1.6
Undetermined (Fe, Zn, etc.).....	7.7

ROASTED GALENA-LIME MIXTURE AFTER SECOND GLOW	
Lead sulphide.....	Nil
Lead sulphate.....	Nil
Lead oxide.....	56.0
Lime.....	6.2
Calcium sulphate.....	29.5
Silica.....	1.5
Undetermined (Fe, Zn, etc.).....	6.8

It will be seen from the analyses that during the first glow some lead sulphide was converted into sulphate, and a considerable amount into lead oxide; also that calcium sulphate was formed. Between the end of the first glow and the end of the second glow the whole of the remaining lead sulphide and lead sulphate has been converted into oxide, and a considerable amount of calcium sulphate has been formed; in fact, the whole

of the sulphur remaining in the material is now present as calcium sulphate.

(b) *Ordinary Roasting Process.*—Experiments with silica mixture. Preliminary experiments with mixtures of galena and silica show that only a dull redness is produced at a temperature corresponding to that at which the first bright glow appears when lime is present, and also that the second glow is hardly perceptible. Much larger quantities of sulphur dioxide were noticed during this roast than in the case of the lime mixture, and also much larger quantities of fume were evolved.

The results of the temperature readings on roasting a mixture containing 80 per cent. galena and 20 per cent. silica, are plotted in the curve *AB*, Fig. 2, the curve *CD* showing the rate of heating the muffle.

On examining this curve it will be seen that, between 180° C. and 290° C., there is a small evolution of heat due to burning sulphur, and then the temperature rises steadily to 535° C., when there is an evolution of heat which is small in comparison to that taking place at about the same temperature (560°) in the case of the lime mixture; another evolution of heat is noted at 730° C., corresponding to, but more marked than that taking place at 745° in the case of the lime mixture. A third evolution of heat is noted at 810°, this being small as compared with that which occurs at 800° in the lime mixture.

Experiments on the changes in weight during the roast show that: On heating to 700° the charges gained 3.9 per cent. in weight, and on heating to 850° C. the charges gained 7.2 per cent. in weight. Analysis of the various mixtures gave the following figures:

ORIGINAL GALENA-SILICA MIXTURE	
Lead sulphide.....	72.6
Silica.....	21.7
Undetermined (Fe, Zn, etc.).....	5.7
	100.0
AFTER HEATING TO 700°	
Lead sulphide.....	30.0
Lead sulphate.....	26.7
Lead oxide.....	17.8
Silica.....	21.2
Undetermined (Fe, Zn, etc.).....	4.3
	100.0
AFTER HEATING TO 850°	
Lead sulphide.....	1.0
Lead sulphate.....	51.1
Lead oxide.....	22.7
Silica.....	21.0
Undetermined (Fe, Zn, etc.).....	4.2
	100.0

Qualitative tests were carried out for peroxides and none were found in the material which had been heated to 700°, and the minutest trace in the material after heating to 850°.

From these analyses it is seen that the reaction which takes place between 535° C. and 700° C. results in the partial oxidation of lead sulphate to oxide and sulphate. On carrying on the roasting operation to 850° C., the almost complete oxidation of the lead sulphide is effected under the condition of the experiment, resulting in the formation of further quantities of lead oxide and sulphate.

From an examination of the curves in Figs. 1 and 2, in conjunction with the results of the analyses it is evident that in the lime mixture and in the silica mixture similar reactions take place at temperatures about 550°, 735°, and 800°, but that in the presence of lime there is an increase in the amount of heat evolved, at any rate at 550° and 800° C.

The following reactions are suggested as explanatory of the various phenomena noted:

The small evolution of heat between 180° and 300°, due to burning sulphur, is probably due to the presence of small quantities of iron pyrite in this sample of galena, as this heat evolution was not obtained with several other samples of galena examined. The fact that the original sample contained 2.4 per cent. of iron, together with the well-known fact that iron pyrites loses part of its sulphur at a comparatively low temperature, confirms this suggestion.

At a temperature of about 550° rapid oxidation of the galena commences, some lead sulphate is formed, and in the presence of lime some calcium sulphate also is formed. At about 735° a reaction occurs between the sulphate and sulphide of lead, calcium sulphate also is formed by the sulphur dioxide when lime is present, but a further quantity of lead sulphate is formed in the absence of lime. At about 800° C. a reaction occurs between the lead oxide formed and any remaining sulphide, the sulphur dioxide evolved again forming calcium sulphate in the presence of lime and lead sulphate in its absence. The metallic lead formed by the reactions (commencing at 735° and 800°) is immediately oxidized to lead oxide, at any rate on the surface of the charge.

On taking into account the thermal values of the reactions indicated above, it will be seen how exactly they correspond to the changes noted on the temperature curves.

In the case of the galena-silica mixture, Fig. 2, at 535°, the following reactions occur:

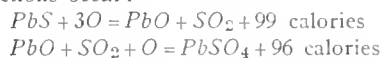

It must be remembered that the whole of the lead oxide formed by the first reaction is not converted to sulphate by the second reaction. This is clearly shown by the analysis.

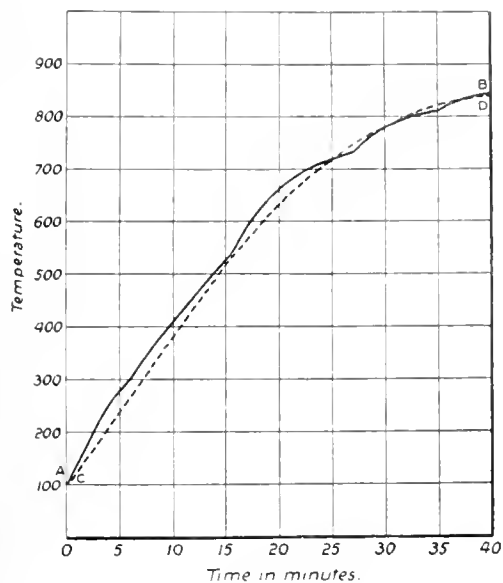
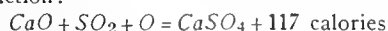

FIG. 2. GALENA-SILICA ROAST

In the case of the galena-lime mixture, there is a greater tendency for calcium sulphate to be formed than lead sulphate, owing to the fact that its formation is the result of a more exothermic reaction. Analysis also proves that calcium sulphate is formed as a result of the reactions commencing at about 550°, and, in addition to the reactions given, there is the important additional reaction:



The fact that this reaction is more exothermic, and that in the presence of lime larger quantities of sulphate are formed, accounts for the decided glow noticed in the lime roast.

The mechanism of the chemical reaction by means of which sulphate of lead or calcium is formed from the oxide, sulphur dioxide and oxygen, is not easy to explain, the formation may, however, be due to one of the following reactions; it may be due to the formation of sulphur trioxide from sulphur dioxide and oxygen, some material present exercising a catalytic effect, the reaction being:

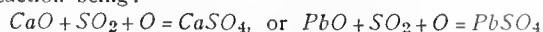

In the second place, it may be due to the formation of peroxides which combine with sulphur dioxide, thus:

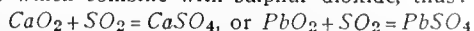

Thirdly, it may be due to the temporary formation of sulphites, which are immediately oxidized to sulphates, thus:

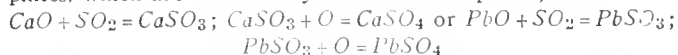

In any case, whatever the exact reaction may be, there is no doubt that lead sulphate is formed during the early part of the roasting of galena, and that calcium sulphate is formed during the early part of the roast of galena and lime mixtures.

Turning now to the reaction which occurs between 730° and 750°, there is little doubt that with the galena-silica mixture, this consists of a reaction between sulphate of lead already formed and some of the unoxidized lead sulphide remaining, thus:

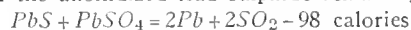

Experiments carried out in crucibles on mixtures of lead sulphide and sulphate indicated that an endothermic reaction took place just above 700°, and the change in the slope of this curve, Fig. 2, at about this temperature also indicates that an endothermic reaction is commencing. The slight rise in temperature that afterwards takes place indicates that the endothermic reaction is followed by exothermic reactions, and these latter consist of the oxidation of the metallic lead formed by the first reaction, at any rate near the surface, and also the formation of a further quantity of lead sulphate, thus:

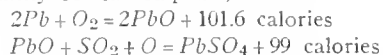

In the case of the galena-lime mixture the reactions are similar, except that in the case of the last equation we have:

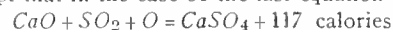

The reason that the effect of this reaction is less marked on the galena-lime curve is that there is present a much smaller amount of lead sulphate to react with the sulphide.

The chemical changes which occur at about 800° C. are reactions between the sulphide and oxide of lead. In the case of the galena-silica mixture, this reaction was entirely absent in some of the curves and only slightly indicated in others, this probably being due to the oxidation of the whole of the sulphide of lead before this temperature was reached.

The thermochemical data of the reactions at this point are:

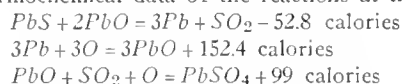

The smallness of the heat evolution in the galena-silica mixture reactions is due to the small quantity of lead sulphide left at this temperature to react with the oxide, most of the sulphide left after the oxidation of the sulphide, between 535° and 700°, having reacted with sulphate of lead between 700° C. and 800° C. In the case of the galena-lime mixture the heat evolution at 800° C. is always very marked, and the mass glows almost as brightly as it does at 560°. The endothermic reaction between lead sulphide and oxide here first takes place, and is rapidly followed by two exothermic reactions, which are, the oxidation of the metallic lead formed by the first reaction and the formation of calcium sulphate by the combination of lime, sulphur dioxide, and oxygen, thus:

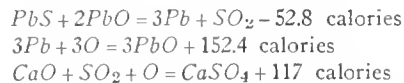

In the presence of lime, the formation of sulphate is much more complete than in its absence, and much less sulphur dioxide is evolved as gas

It will be noticed that the experimental work so far described, and the theory put forward, only deal with reactions taking place up to a temperature of 850° C. or thereabouts. The reason for this is, that the reactions taking place in this range of temperatures have caused the large amount of controversy in the past, and also that the correct interpretation of the reactions which take place beyond this temperature is already understood and generally accepted. These reactions consist of the decomposition of lead sulphate, when this compound is present, preferably

by silica, with the formation of lead silicate; and when calcium sulphate is present, this is also decomposed by silica when a sufficiently high temperature is reached. This accounts for the small amount of sulphur left in the product of the blast pots under some conditions of working the processes, and also accounts for the larger amount of sulphur dioxide in the gases from the Carmichael-Bradford process than could be obtained

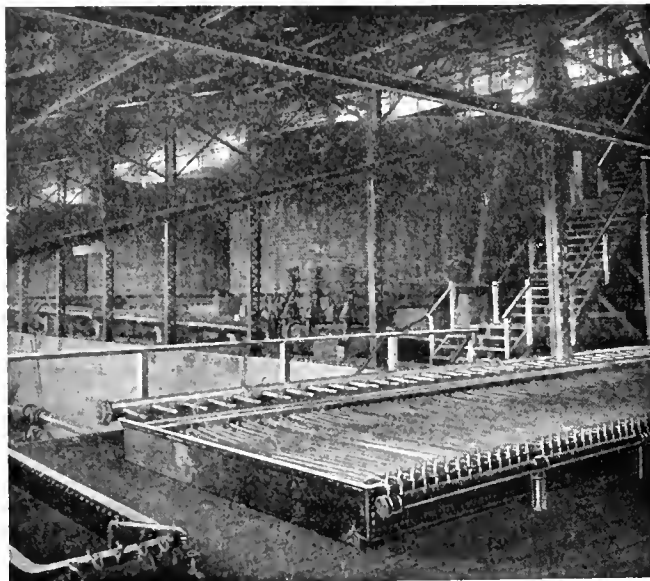

FIG. 1. FILTERS, PULP, SOLUTION AND WATER STORAGE TANKS

from the oxidation of lead ore alone. The accuracy of this interpretation was confirmed by a number of experiments. In some of the roasting experiments which were carried to a high temperature, distinct endothermic reactions occurred between 1,050° and 1,200°, during which sulphurous fumes were evolved freely, showing that the sulphates previously formed were being decomposed.

來 來

United States Copper Production

The copper mines of the United States have produced more than fifteen and a quarter billion pounds of copper, and of this total 12 mining districts have produced in excess of 100,000,000 pounds each, according to the United States Geological Survey. These 12 districts located in eight states, have yielded 94.69 per cent. of the total output of the country since 1845, when the total product of the United States was but little more than 200,000 pounds. These districts are Butte, Mont., which has yielded 5,315,000,000 pounds, or 34.75 per cent. of the total production; Lake Superior, Mich., which has yielded 4,756,000,000 pounds; Bisbee, Ariz., 1,285,000,000 pounds; Morenci-Metcalf, Ariz., 882,700,000 pounds; Jerome, Ariz., 570,000,000 pounds; Bingham, Utah, 465,000,000 pounds; Shasta County, Cal., 336,000,000 pounds; Globe, Ariz., 334,700,000 pounds; Ducktown, Tenn., 211,700,000 pounds; Ely, Nev., 125,000,000 pounds; the foot-hill belt, California, 104,000,000 pounds; and Santa Rita, N. Mex. (where mining has believed to have been begun as far back as 1800), 103,000,000 pounds. All other districts have produced 801,300,000 pounds.

The first ten districts are the ten largest producers today, although the order is slightly changed. These ten districts yielded 93.84 per cent. of the production for 1910. The United States is by far the greatest copper-producing country, our smelter output of copper in 1910 being 56.75 per cent. of the total for the world.

Nearly every one of the leading copper-producing districts of the United States, according to the Geological Survey, made a record output within the three years preceding 1910.

Goldfield, Nev., Cyanide Mill

Methods of Handling the Ore, the Pulp, and the Solutions Through Pumps, Filters, Etc.

The Goldfield Consolidated Mines Co.'s mill, while not so large as some others, is one of the most modern cyanide mills so far constructed anywhere. The electrical power for operating the mill is obtained from the hydroelectric stations at Bishop, Cal., of the California-Nevada Electric Power Co. Electric motors are extensively used for individual machines and for general power.

A diagram of the operations to which the ore is subjected in the mill has the same general relation to the metallurgist as the steam engine diagram has to the mechanical engineer. Therefore, the description of the flow sheet, Fig. 3, is inserted in this article. When in this case the ore reaches the mill it is dumped from the cars into a 44'×20' bin having a capacity of 850 tons. The ore as it leaves this bin passes through gyratory crushers, then 14'×4' revolving screens with 1½-inch holes. The oversize from the screen is recrushed and is carried with the undersize from the screen on a conveyer belt 370 feet long to an automatic weighing machine. After weighing it is sampled mechanically, a 5-per-cent. cut being taken, and is then, with the reject, carried on a conveyer belt to the mill bin. This bin, which has a capacity of 4,000 tons, is supplied with twenty 18"×24" gates, through which ore passes to automatic ore feeders suspended between the bins and the stamp batteries. The stamps weigh 1,050 pounds each and crush wet, delivering the product to silver-plated copper amalgamating plates 16 feet long and 5 feet wide. At the discharge end of the plates the launders are connected with amalgam traps to recover quick-silver and amalgam before the pulp is discharged into the twin-cone hydraulic classifiers. From the classifiers the underflow or spigot product goes to pulp thickeners and the overflow to another set of cone classifiers that furnish material for the tables.



FIG. 2. CENTRIFUGAL PUMPS FOR RETURNING SURPLUS PULP SOLUTION TO STORAGE TANK

The thickeners are of the Dorr type and delivered their product to tube mills 22 feet long by 5 feet diameter, in which as much as possible of the material is pulverized to pass 200 mesh, after which it flows to large cone classifiers 4 feet in diameter, with a sand-pump attachment and launder distributor. From this distributor the overflow goes to secondary amalgamating plates, and two amalgam traps.

The overflow from the first classifiers with the overflow from the amalgamating plates goes to a distributor, then to cone classifiers. The spigot product flows to shaking tables, the overflow going to settling tanks. It is stated that four-fifths of the pulp passes 200-mesh screen and concentration is practiced only after tube milling, making the process one of virtually all slime. The overflow from the classifiers joins the product from the concentrating tables and is distributed to settling tanks 12 feet high and 20½ feet in diameter with cone bottoms. A 6-inch centrifugal

slime and solution are in the proportion of about 2 to 1, after which it is distributed to Pachuca tanks. These tanks are shown in Fig. 4 above the platform. They are of steel, 15 feet in diameter and 45 feet high. In these tanks the thickened slime is agitated

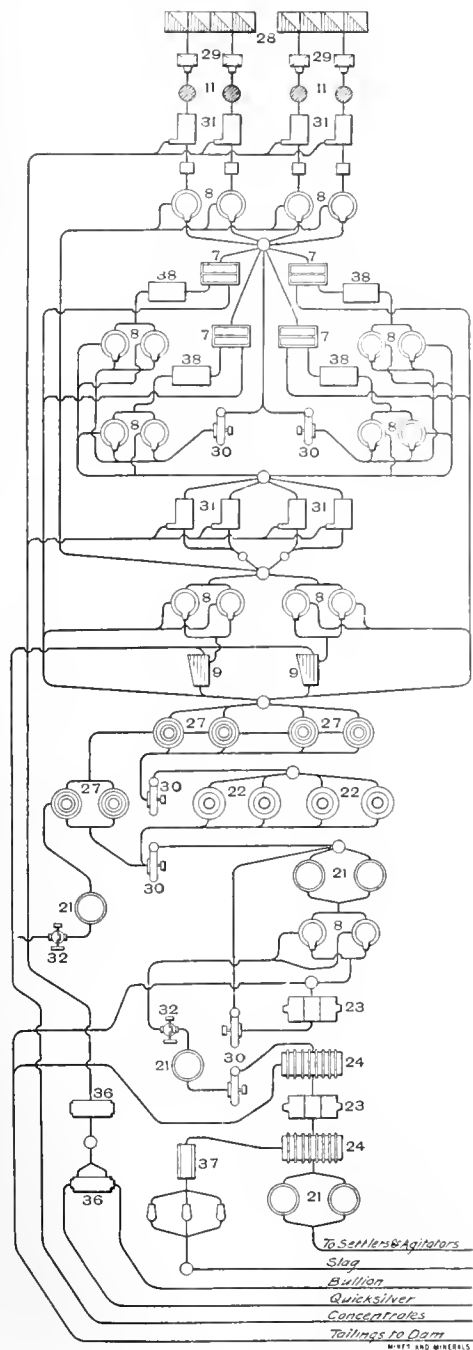

FIG. 3. FLOW SHEET OF CYANIDE MILL

- 7, Settling Box; 8, Classifiers; 9, Concentrating Tables;
- 11, Stamp Batteries; 21, Cyanide Tank; 22, Agitators;
- 23, Precipitation Tank; 24, Filter Press; 27, Callow Tank;
- 28, Ore Bin; 29, Ore Feeder; 30, Centrifugal Pump;
- 31, Amalgamation Tables; 32, Power Pump; 36, Retort; 37, Furnace; 38, Thickener

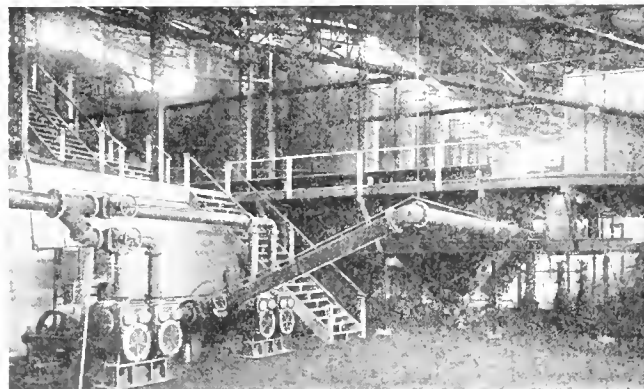

FIG. 4. VACUUM PUMPS AND ENDS OF FILTER BOXES

in cyanide solution by compressed air for a number of hours, after which it is drawn off into a 34-foot diameter classifier connected with an electrically operated centrifugal pump which feeds two launder distributors that connect with a pulp-storage tank 34 feet in diameter and 24 feet high, also with a weak solution and a water tank 39 feet in diameter and 8 feet high. These tanks are shown in Fig. 1. In front of them is the pipe line and in about the center of the illustration is seen the 16-inch quick-opening valves for filling the pipe line. In the foreground of the same illustration a part of one of the vacuum filter tanks is seen, and to the left of this the filter-cleaning tank.

The centrifugal pumps installed for returning the surplus solutions and water to the storage tanks are shown in Fig. 2. They are direct connected to high-speed, three-phase, induction motors. The thickened pulp, after continued agitation in the storage tank, is allowed to flow into two filter boxes, one of which was shown in Fig. 1. Each box contains 168 Butters vacuum-filter frames and treats 369 tons of dry slime in 24 hours. The underside of these filter boxes, shown in Fig. 5, is hopper shaped for the purpose of quick filling and discharging. The 16-inch hydraulic quick-opening valves in the discharge pipe and the valve operating mechanism under the filter boxes is also shown. The gold solution is drawn

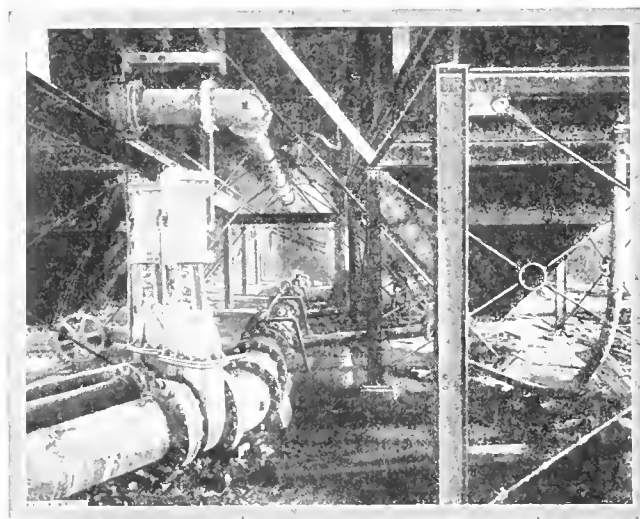

FIG. 5. VALVE-OPERATING MECHANISM UNDER FILTER BOXES

pump operated by an electric motor is connected with the spigot product from these tanks and pumps that material to a distributor. The overflow from the large cone settling tanks goes to two other similar tanks. The cone settling tanks reduce the pulp until

through the filter leaf by vacuum and leaves the slime coated on the outside.

The vacuum pump that draws the solution through the filters is shown in the left foreground of Fig. 4. From the filter press

the gold solutions are pumped to precipitation tanks where they are treated with zinc dust to precipitate the gold. The precipitates in suspension from these tanks are forced by the triplex power pumps, shown in Fig. 2 in the foreground, into 48-inch, 50-frame filter presses which collect the precipitates and pass the weak solution on to tanks from which it is pumped to storage tanks.

The product from the zinc filter presses is dried in a furnace and melted in five Faber Du Faur tilting furnaces. It is maintained that no acid is used in the treatment of precipitates. The Hutchinson sulphuric-acid process is used in the treatment of concentrate, thus avoiding the necessity of sending it to the smelters. The amalgam barrel, press, and retort treat the material coming from the amalgamated plates previous to its going to the bullion furnace.

The mill-water sump tank is connected with the larger 1,300-gallons per minute triplex pump shown in the right foreground, Fig. 2. For water supply there is a 1,000,000-gallon fresh-water reservoir and two tanks for clear mill water, each 24 feet in diameter and 16 feet high.

It is stated that an extraction of 95 per cent. has resulted from this process and it is maintained that the mill is handling more than a million pounds of ore per day, coming largely from the Mohawk and Combination mines, and running about \$40 per ton. It is held that the total cost of milling the ore, as well as developing, mining, and transporting the same, does not exceed \$6 per ton.

采 采

Copper Combines and Mergers

The following is abstracted from an address by Horace J. Stevens on the "Past, Present, and Future of Copper," delivered before the American Mining Congress at the Chicago meeting, 1911:

At various times in the past efforts have been made at copper corners, but these have proven uniformly unsuccessful. The first copper corner was by the Associated Smelters, of Swansea, and might be termed the original copper trust. The Associated Smelters, which flourished from 1840 to 1860, were most arbitrary in their operations, buying cheaply, selling dearly, and zealously guarding their smelting processes. As a result of the very shortsighted policy of screwing prices of ore and matte to the lowest possible figures, while selling the finished product at the highest possible prices, with the ore producers aggravated by arbitrary charges for draftage and moisture, and the further grievance of unfair assay methods, the mine owners were led to build independent smelters at and near the mines, in most of the principal copper-producing districts, thus destroying the power of the Associated Smelters of Swansea as the arbiters of the copper industry.

The second attempt at a copper corner was made by the Société des Metaux, of Paris, under the leadership of M. Secretan, the Société des Metaux becoming, in February, 1887, one of the 16 underwriters that organized the Syndicat Secretan, with a nominal capitalization of \$13,587,000. This syndicate contracted with the leading copper producers for their output, and speedily advanced the price of the metal to 17½ cents, effecting an increase of more than 50 per cent. in price within 1 month. Consumption immediately declined to a low figure, and the Secretan Syndicate borrowed enormous sums to carry its rapidly accumulating copper, from French, German, and English banking houses, the Comptoir d'Escompte of Paris alone lending the enormous sum of \$33,368,000 to the Syndicat Secretan. This corner broke early in 1889, after about 18 months existence, and in a single day, in the spring of 1889, the price of copper dropped from £70 down to £35 per long ton. About 1 year was required to clean up the wreckage.

The third attempt at a copper corner was made in February, 1899, by the organization of the Amalgamated Copper Co., which corporation maintained the price of copper, arbitrarily, at 17 cents per pound, until October, 1901, when an accumulation of 200,000,000 pounds of metal compelled a break that took the price of copper down to about 12 cents per pound, and about 3 years were required by the industry to recover from the effects of this corner.

The price of 26½ cents per pound, reached in March, 1907, by

Lake copper, was not the result of any corner, but came about through an ill-advised scramble by consumers, who feared that they could not secure the metal. As a result of the high price, consumption was curtailed sharply in all directions, as happens inevitably under such unsatisfactory price conditions, and the copper industry of the world still suffers from the existence of a surplus of slightly under 300,000,000 pounds of metal, remaining from a surplus that, including both visible and invisible supplies, reached about 450,000,000 pounds at the end of 1909, since which time there has been a small but steady decrease in surplus from month to month.

In the copper industry the great bulk of production now is furnished by about a dozen different interests. The Amalgamated Copper Co. has a productive capacity of about 300,000,000 pounds yearly, with an actual output last year of 223,808,546 pounds. The American Smelting and Refining Co., or Guggenheim interests, have a productive capacity only slightly inferior to the Amalgamated, with an actual output of 174,150,000 pounds in 1910, which figure will be exceeded materially this year. The production of Phelps, Dodge & Co. was 116,888,070 pounds in 1910, while smelter production, including custom ores treated, was 138,805,562 pounds, and the sales agency of this firm handled 194,138,696 pounds of copper last year. The Calumet & Hecla, with its subsidiaries, has a productive capacity of nearly or quite 150,000,000 pounds yearly. The Rothschild interests, controlling the Rio-Tinto of Spain, and the Boléo of Mexico, have a copper output of more than 100,000,000 pounds yearly.

The leading copper producers of the world are now operating under check, a 10-per-cent. reduction in output having been put into effect in August, 1910. [Notwithstanding this curtailment, the total production of copper in 1911 was greater than any previous year since 1909.—EDITOR.] Under the Sherman anti-trust law, this checking of production would be considered criminal, if it could be proven, yet the reduction of output was absolutely necessary in order to save the copper industry from a prolonged period of utter demoralization, during which scores of millions of dollars would have been lost by investors, and a quarter million or more of workmen would have suffered severely, many of them losing their jobs, and the remainder suffering severe cuts in wages.

采 采

California Natural Gas Law

The following California law providing a penalty for permitting the unnecessary waste of natural gas from wells, was approved March 25, 1911.

SEC. 1. All persons, firms, corporations and associations, are hereby prohibited from wilfully permitting any natural gas wastefully to escape into the atmosphere.

SEC. 2. All persons, firms, corporations or associations, digging, drilling, excavating, constructing, or owning, or controlling, any well from which natural gas flows, shall upon the abandonment of such well, cap or otherwise close the mouth of or entrance to the same in such a manner as to prevent the unnecessary or wasteful escape into the atmosphere of such natural gas. And no person, firm, corporation or association, owning or controlling land in which such well or wells are situated, shall wilfully permit natural gas flowing from such well or wells, wastefully or unnecessarily to escape into the atmosphere.

SEC. 3. Any person, firm, corporation or association, who shall wilfully violate any of the provisions of this act shall be deemed guilty of a misdemeanor, and upon conviction thereof, shall be punished by a fine of not more than \$1,000 or by imprisonment in the county jail for not more than one year, or by both such fine and imprisonment.

SEC. 4. For the purposes of this act each day during which natural gas shall be wilfully or unnecessarily allowed to escape into the atmosphere shall be deemed a separate and distinct violation of this act.

SEC. 5. All acts or parts of acts in conflict herewith repealed.

SEC. 6. This act shall take effect immediately.

Square-Set Mining at Vulcan Mines

Adaptability of the System of Mining to Ore Bodies of Irregular and Various Shapes

By Floyd L. Burr*

The following paper, extracted from the proceedings of the Lake Superior Mining Institute, will be found valuable to those interested in square-set timbering and mining.

Since the introduction of the square-set timbering by Philip Deidesheimer in 1860, at the Ophir mine on the Comstock lode in Nevada, it has been used under widely varying conditions and may be considered to possess in a very marked degree the qualities of safety, thoroughness and general conservatism; while it is always open to criticism on the score of expense. Being used under vary-

“legs” or the “dividers” may have to carry the heaviest load, and indeed they must always carry certain component parts of the main load. It must also be borne in mind that the timber is used incidentally as staging from which to carry on the work of mining and to support temporarily considerable broken ore. These incidental functions of the timbers have a strong bearing on their manner of use and in the selection of size.

There are many systems of details for framing the ends of the pieces to form the joints, depending on the conditions of pressure, cost, facilities for framing, etc., as these conditions appear to the man who directs the mining operations; but timbering is carried out too generally by a blind following of the local time-honored method with little consideration of the actual requirements. To design a joint scientifically, one must first decide as to the magnitude and direction of the pressure and stress to be resisted and then dispose the timber in such a way as to best serve the purpose, it being of paramount importance to remember that timber is about

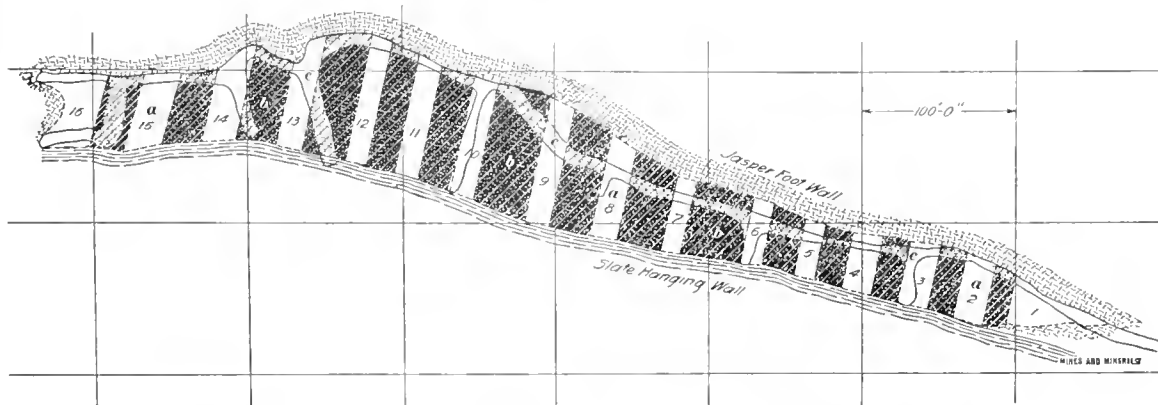

FIG. 1. PLAN, SHOWING DEVELOPMENT DRIFT AND OUTLINE OF ROOMS AND PILLARS

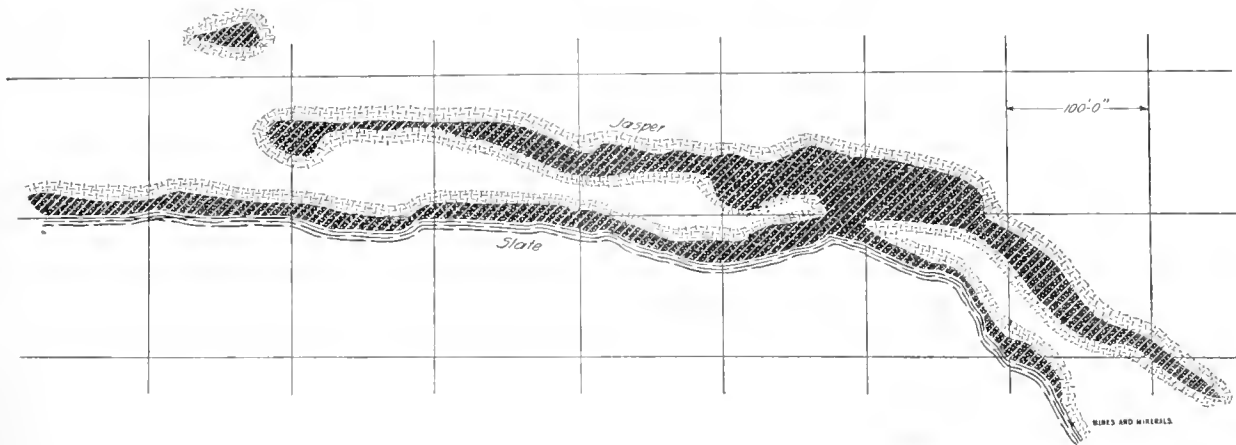

FIG. 2. PLAN, SHOWING IRREGULAR SHAPE OF ORE BODIES

ing conditions and by men with widely varying ideas, it is not surprising to find considerable differences in the dimensions of the timber, in the detail of the joints and in the application of the system.

Square-set timbering was developed to take the place of stulls when the Ophir mine vein suddenly widened out, with depth, from 4 feet to about 70 feet. It was of course impracticable to span such a width between the hanging and foot-walls with one-piece stull timber and in order to produce what would be in effect a prop made up of several pieces, the square-set scheme was devised. The idea was that the compressive stress due to the weight of the hanging wall would be resisted by a series of “caps” butting against each other and held in alinement by other members acting at the joints. This conception of the function of the caps makes them the principal members, the others being more of the nature of auxiliaries. Probably this condition is most nearly true in case of steep dips. However, in the use of the system in general, there are places where the

*Vulcan, Mich.

five times as strong to resist compression along the grain as it is across the grain.

Square-set timbering has made possible and given rise to a number of square-set systems of mining. That in use by the Penn Iron Mining Co. at its Vulcan mines might be called the “square-set room-and-pillar” system of mining. There are several other mining methods in use at these mines, the most notable of them being the “top-slicing” system, which is sometimes used independently, but more often as an auxiliary to the square-set work to mine out the ore pillars left between the square-set rooms. In the mining of soft or medium ores, the square-set room-and-pillar method is applicable, where the ore body is too wide for stull timbers; where it is so irregular in shape that the width is liable to vary greatly and unexpectedly; where the conditions of the rock back is such that it will not cave successfully for the top slicing method; where caving methods in general cannot be used for fear of destroying valuable or essential surface works; where previous operations

have rendered underground conditions unfit for caving methods; where it is necessary to begin mining on several levels at once instead of progressing only from the top downward; where the output must be forced in quantity or in date; where it is considered essential to recover with certainty all the ore; and in general where conservatism is the ruling factor.

Due to the existence of some of the above conditions at Vulcan, the system has been quite generally used there. Levels are usually established at 100-foot intervals, and when the ore body is encountered the drift is continued throughout the length of the ore, there being no regular practice as to following the foot or hanging walls or drifting in the middle. Some cross-cutting is done at irregular

length is of course the width of the ore body. The intervening pillars vary in width from two sets to five sets.

Fig. 1 shows the plan of a certain level in one of the Vulcan mines being worked by the square-set system. This ore body is larger and more regular than many of them, but the smaller and irregular ones are worked the same way. In the illustration an irregular development drift has marked out the ore in a general way and then rooms have been laid out, leaving pillars between them. In the figure, the area occupied by pillars is shaded. Fig. 2 shows the irregularity in size and shape common in the Vulcan ore bodies.

As the rooms are gradually cut out on the level, square sets of timber are placed in position and usually a set is placed as soon as there is space for it, thus avoiding large areas of unsupported back. The sets are blocked in place and 7-foot lagging is laid on top. Usually 9-foot legs are used for the first floor, while all other floors have 7-foot legs. These lower legs are usually stood directly on the ore beneath, it not being found necessary to use sills to distribute pressure or to tie the legs together. Years ago sills were used regularly. The only reason for using sills would be to facilitate the "catching up" of the debris when the room has been filled with waste rock and the workings below have progressed up to the level. Instead of using sills, the present practice is to anticipate the beginning of the filling operation by laying down a sheeting of 10-foot round lagging on the floor of ore at the level, it being comparatively easy to "catch up" this lagging when working up to it in the subsequent operations from below, and to thus avoid the caving down of loose filling material. The sides of the rooms next to the pillars are lagged up outside the legs of timber to prevent the ore from the pillar caving into the room.

After a given room has been cut out and timbered one set in height over the whole area from hanging to foot-wall, thus completing the "first floor," the lagging is removed over one set and an opening is cut upward large enough to accommodate a set of timber, thus beginning the "second floor." This floor and the succeeding floors of ore are in due time mined out, one set at a time, and the timbering left in its place until the level above is reached, or to a point some 15 feet under the level in case it is necessary to leave a floor to accommodate haulage ways or other conditions on the level above. In the most usual case when a 15-foot floor pillar is left, a raise is cut through it connecting to the level above, as shown in Fig. 3.

In blasting down the ore, it is allowed to accumulate to some extent on the various lagging floors and occasionally the "stope is cleaned up" by shifting the lagging like the dump-boards of gravel wagons, allowing the ore to fall down into the chutes which have been provided at the level. The various rooms in the series will generally be found in different stages, some being worked nearly up to the limit, while others are barely begun.

In the usual course of action, the rooms are filled up with waste rock produced elsewhere in the mines by the driving of exploratory drifts and other openings or sent down from surface rock piles in cars or chutes; or in case these sources do not yield the necessary material, rock is mined for the purpose from suitable places in the hanging or foot-walls. This rock is trammed in cars and dumped down from the level above until the room is full. Of course, the timbers are left in place and no attempt is ever made to recover them. Before starting to fill a room, a sheeting of split lagging is placed at the side of the room bearing against the legs toward the pillar to prevent the subsequent rock filling from running out when the pillar is being worked later.

I understand that some years ago at the West Vulcan mine the filling was "puddled in" with water and the result was a material like a water-bound macadam, concrete-like in its ability to stand up as a rigid mass. This, I presume, would hardly have required the support of lagging.

Whatever passage ways it is desired to maintain are cored out in the rock filling. These may include a ladderway between levels, tramways on the lower level, and suitable mills adjacent to the pillars. These mills are to be used for access to the pillar and for

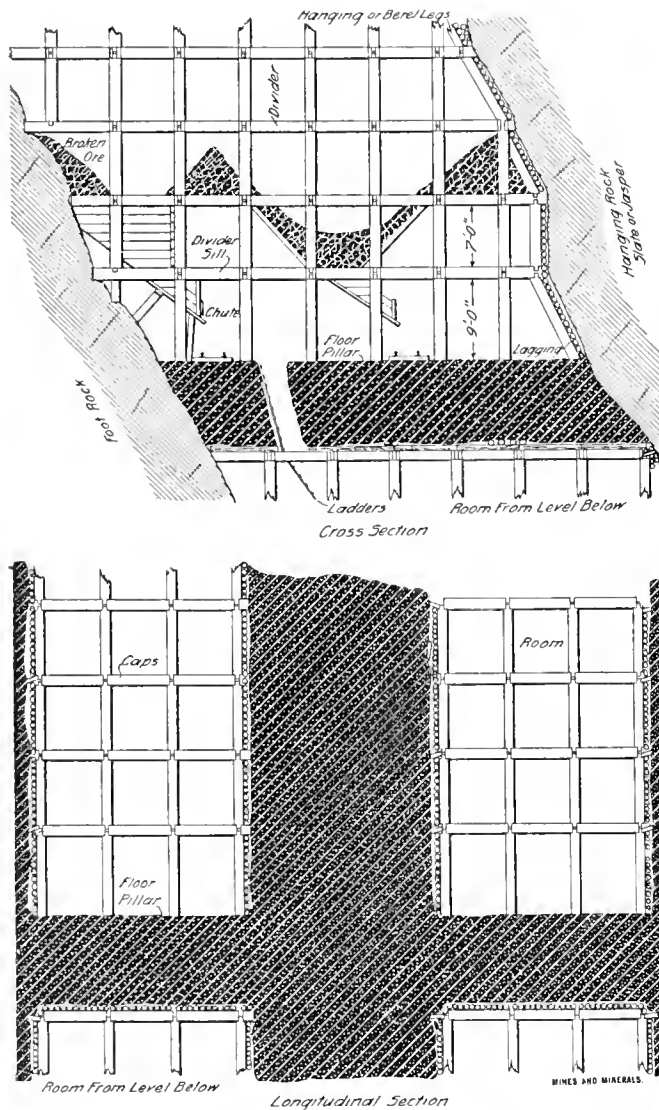

FIG. 3. VERTICAL SECTIONS SHOWING SQUARE SET TIMBERING AND SCHEME OF MINING

intervals, thus defining the general limits of the ore body. Frequently raises are driven upward to connect with the level above for ventilation and for lowering timber.

In beginning the mining operation, a line for the timbering is chosen, sometimes paralleling the timber work on the level above and sometimes being a line parallel to the longitudinal axis of the ore body, as nearly as may be approximated from the development done. When there are pillars of ore still unmined on the level above, it is of course considered essential to keep that in mind in the laying out of room and pillars, which comes next in sequence. At right angles to this longitudinal line which has been chosen for the timbering, rooms are laid out. These rooms are made from two to four sets, or from 14 feet 10 inches to 29 feet 8 inches wide and their

chutes down which the ore is sent when mining these pillars by the top-slicing method. When all the rooms have been worked out and filled, the pillars are usually attacked by the well-known "top-slicing" method. By this method the ore is mined from the top of the pillar in a "slice" only some 10 feet in depth and the debris above caved down as each successive slice is removed. At the same time the floor pillar left over the adjacent rooms may be removed.

While the method as outlined might be called the standard method, it is frequently departed from in several ways. Thus sometimes the pillars are worked away as extensions of the rooms by what is known locally as "side slicing." This side slicing has been used considerably. To explain it, suppose a pillar three sets wide between two rooms each three sets wide. After the rooms have been excavated and the square-set timbering occupies the space, it may be found that no severe strain has shown its effects upon the timbering and the ore pillar shows no tendency to cave. Under these circumstances it may seem wise to risk taking off a slice one set wide from one side of the pillar. This then widens the adjacent room to four sets wide and reduces the pillar to two sets wide. This space is of course timbered with square sets precisely like those in the rooms, progressing from set to set and floor to floor. After this one slice has been successfully cut off from the pillar, we may be bold enough to risk taking off a similar slice from the other side and finally removing the remaining third, producing a great room nine sets wide; or it may be considered too risky to do this and resort be made to filling the rooms and top slicing the remaining portion of the pillar.

Sometimes the above described procedure is carried on with the variation that the rooms are filled in the usual manner with waste rock before attacking the sides of the pillars. Sometimes also after the rooms have been filled with waste rock, the pillars are "taken out on timber," as it is spoken of locally. In this scheme the pillar is treated just as if it were a room and the filled room a pillar, the whole three sets width of pillar being mined up and timbered with square sets.

Taking up now the details of timbering, reference should be made to the sketches. In Fig. 4 the joint is shown in modified isometric projection. The sketch represents 12-inch timbers, but 10-inch and 16-inch timbers are also in use, the tenons on the legs being made 4 inches and 8 inches square, respectively. It will be

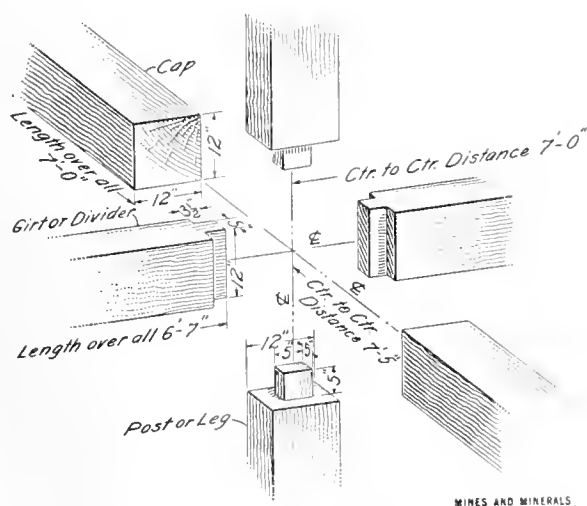

FIG. 4. SQUARE-SET JOINTS

noticed that the framing is extremely simple. A great deal of the timber is framed by machinery, but there is also some hand-framing. Both round and square timbers are used.

Fig. 5 shows a "divider sill" and a "cap sill" and their use is indicated in Fig. 3. The "divider sill" is used to allow the timbering to progress over the foot-wall, while the "cap sill" may come into use in a similar way at the end of the ore

lense at the foot of the pitch. The "beveled post" or "hanging post" is used in following up the hanging wall.

Contrary to the more usual practice, the caps are placed along the strike of the vein and the dividers at right angles. The reason for this is that it is desired to place the overhead lagging in the direction from foot-wall to hanging wall, and since it must take the weight

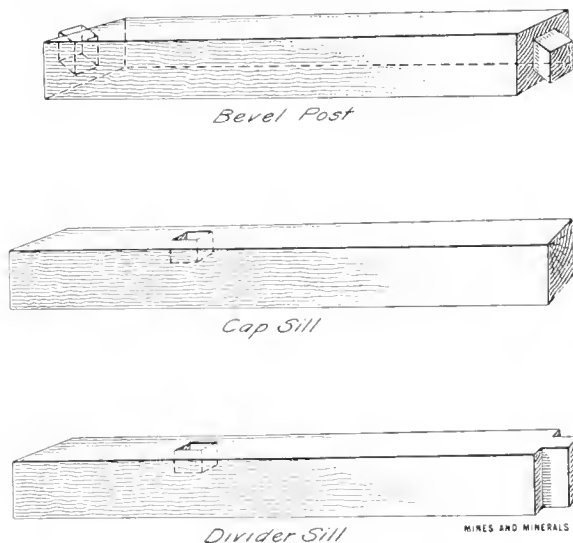

FIG. 5. DETAILS OF MEMBERS

of ore blasted down upon it, it must rest on the stronger members—the caps—the caps being the stronger because they have the greater bearing area on the leg.

The legs are spaced 7 feet center to center from foot-wall to hanging wall, while in the longitudinal direction they are at 7-foot 5-inch intervals.



Repairing a Spur Wheel

It not infrequently happens, by reason of a faulty casting or sudden and severe shock, that a tooth is ripped from a spur wheel. A common method of making temporary repairs is to shape a new tooth in the blacksmith shop and bolt it to the wheel by bolts through holes drilled in the tooth and the circumference of the wheel. While giving most excellent results, this is a slow and tedious process.

A simpler and fully as efficacious a method is used at the Delagua mine of the Victor American Fuel Co. A new tooth is shaped, with a die, from a piece of iron of the right thickness. To this two pieces of iron *c* and *c*, are welded. A seat, the

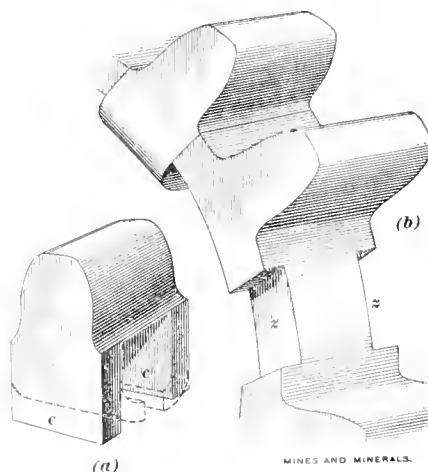

REPAIRING A SPUR WHEEL

place of the broken tooth, is smoothed on the face of the wheel and two slots *z* cut in it. After being heated the prongs, *c* of the new tooth are placed in the slots, *z*, in the rim of the wheel and hammered up against the inner side thereof. Upon cooling they are absolutely tight and firm. In the figure the ends of the prongs are shown in dotted lines as partly bent under in their final position. These teeth have proven durable.

Unwatering Tresavean Mine

Methods of Supporting Pumps, and Clearing and Securing the Shaft—Rate of Progress

[This is abstracted from a very practical paper presented to the Institute of Mining and Metallurgy, London, by Cyril Brackenbury. The Tresavean mine which in the past had an exceedingly good record was pumped out by electric driven pumps so arranged as to do excellent work and obviate the troubles connected with heavy Cornish pit work. The methods adopted for relining the shaft and overcoming the obstacles offered by materials which choked the shaft from time to time and interfered with lowering the pump suction pipe were described in the April issue of MINES AND MINERALS. In this abstract are described the methods of supporting the sinking pumps; the methods of clearing "the choke," that is, the material which stopped up the shaft, and of removing the parts of the old Cornish pump left in the shaft when the mine was abandoned, and the method of securing the shaft when the ground was made bad by a cross-course, that is, where another vein cuts the vein being worked.—EDITOR.]

During the months of October, November, and December, 1910, the rainfall was exceedingly heavy, totaling 23.54 inches. The curves in Fig. 1 show that the incoming water, 265 gallons per minute in the first part of October, increased to 367 gallons per minute the 1st of November and jumped to 950 gallons per

well as by the rope, except when it was actually being lowered or raised in the shaft. In order that the weight of the pump should be taken up quickly and conveniently, two adjustable stretching screws were obtained for each pump, and $\frac{3}{4}$ -inch short-link chains were made in lengths of 25 feet and 9 feet, each chain having a large hook at one end and a large link at the other end. The 9-foot lengths were made with special large links set about the same distance apart as the adjusting length of each stretching screw. This arrangement, together with two large S-shaped hooks about half the length of straining screw, make it possible to tighten up the supporting chains for any position of the pump. The upper ends of the chains were slung round temporary horizontal timbers securely supported in the shaft, and the pump could be suspended 200 feet below these supports on a series of chains hooked together, the special 9-foot lengths only being used at the pump. Each tightening screw was shackled to the eye at the top of each of two steel plates, which were securely bolted to the two channel irons of the pump frame. Two sets of chains were attached to each pump, and these were sufficiently strong to carry the full weight of pump and water column in the rising main, but the chains were never tightened so as to take the full weight, only sufficiently so to take the greatest strain off the supporting ropes. Each time the pump was lowered it only took a few minutes to hang the new chains and tighten them up to the proper position.

The rising main, or column pipe, used for unwatering operations was only temporary. It was a 6-inch internal diameter

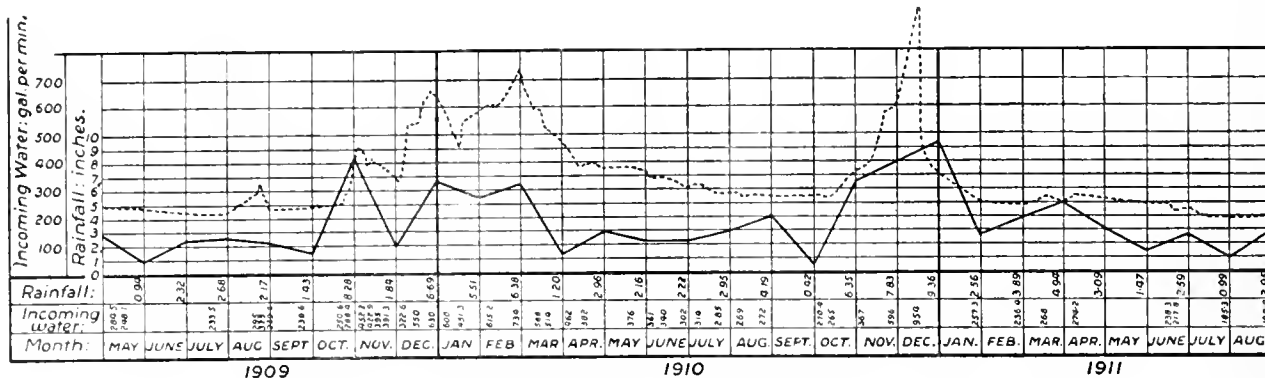

FIG. 1. DOTTED CURVE SHOWS INCOMING WATER, IN GALLONS; HEAVY CURVE, RAINFALL, IN INCHES

minute on December 17, 1910. This caused a set-back to pumping, as the water rose so fast in the shaft it drove the pump back up the shaft 133 feet. From December 17 steady progress was made in recovering the mine.

The writer has seen four other mines using high-lift turbine pumps for unwatering purposes. In one of these cases the pump was slung by a fourfold rope system and in three cases by a twofold rope system. The fourfold system requires two pulleys on each pump and two pulleys for each pump on the head-gear; the twofold system requires only one pulley on each pump and one pulley for each pump on the head-gear. It was decided to use a single fall with large rope attached to a pair of triangular plates carrying a twofold rope sling passing round the pulley wheel of the pump. The single fall rope, although double the strength, has, of course, only to be half the length of a twofold rope, and, consequently, there is only half the length to be looked after and greased. The short sling, which is of just sufficient length to clear comfortably the bend of the delivery pipe, makes a convenient way of supporting the pump frame without straining it.

In this case by taking into consideration the comparatively great depth the water would have to be lowered, it was decided to support the rising main along the walls of the shaft, connecting the lower end by means of a short reverse bend with the top of pump delivery, a telescopic expansion joint being inserted between pump delivery and the bend to rising main. It was further decided that the pump should always be supported by chains as

lap-welded steel pipe with loose flange joints packed with a single rubber washer. The regular length of each pipe was 18 feet, but a few lengths of 9 feet, 6 feet, 4 feet, 3 feet, 2 feet, and 1 foot were used as a convenience when occasion required it. There were two independent 6-inch column pipes fixed in the shaft from the adit to the 75-fathom level, one in each pumping compartment, but below the 75-fathom station there was only one, which was carried down the east pump compartment. It was originally intended to use two pumps and two column pipes in the shaft while unwatering down to the 200-fathom level, but it was found by experience that the old pit work left in the west end of the shaft would seriously interfere with such a proceeding, and, owing to the confined space in the shaft, it was never found advantageous to lower the two sinking pumps at the same time. Moreover, as a general rule the capacity of one sinking pump was sufficient to lower the water fast enough to keep up with the work of clearing, securing and repairing the shaft until the 75-fathom level was reached. After installing the station pumps at the 75-fathom level, each one with its separate rising main, it became possible, until the new pump was started at the 166-fathom station, to run either the sinking pump and one station pump in parallel, or the two 75-fathom station pumps in parallel, and this was done during February and March, 1910, when the quantity of inflowing water from the 75-fathom level was very heavy.

High-lift centrifugal pumps are not suitable for handling the rough material which can be passed through an ordinary

Cornish pump without difficulty. To save wear and tear a strainer of ample superficial area, made of copper plate with $\frac{1}{8}$ -inch punched holes, was used. With a strainer of this kind the sinking pumps have worked satisfactorily, when using a pipe of over 25 feet. The usual length of pump suction pipe varied from about 10 feet to 20 feet, giving an average length of about 15 feet, and 25.2 feet was the greatest length recorded.

The extreme length of suction pipe that can be used depends chiefly upon the condition of the strainer, which, of course, should be clean, and upon how near its hydrostatic head the pump is working; the nearer the limit the less the suction lift allowable. When using a long 4-inch tail-pipe, driven through choke, the friction of the water has considerable effect in reducing the height of suction lift, and this is particularly the case when the quantity being pumped is sufficient to cause a high velocity, that is to say, when the friction head in the suction pipe becomes an important factor. At one time, when there was 73 feet of 4-inch suction pipe through the choke, the theoretical head, due to friction in the pipe and entry of water into the pipe, amounted to about 11 feet.

The thickest choke encountered in the shaft was at and above the 212-fathom level, where it was found to be over 70 feet deep and so compact that the water could only percolate slowly through it. When at first pumping above this choke, the water level in the shaft was continually taken down several feet below the level of the main body of water in the mine; also, when first starting the pumps, the water level would be very rapidly reduced the first 8 or 10 feet in the shaft, and after stopping the pumps the water would rise abnormally fast to begin with. Again, when the 4-inch pointed suction pipe was first driven through this choke, and the point blasted off, although the upper end stood 2 or 3 feet above the water level in the shaft, water began to overflow from the top of it.

It may be interesting to some to have a description of the method of clearing and securing the shaft. In dealing with small chokes under water, various forms of hooks and grabs, on long handles made of $\frac{3}{4}$ -inch to $1\frac{1}{4}$ -inch round iron, were used, also a kind of iron tongs for lifting large rocks or timbers from under water was occasionally used. A drop screw was used more than once in the work of dismantling and taking up the weight of the old pit work. It was used, for example, before removing the supporting timbers, in drawing out each old pole piece from its plunger barrel, for taking apart some of the heaviest pieces of ironwork, and in raising the bottom lengths of pipe in which the old bucket of the lift pump had worked. A large steel-pointed harpoon and heavy iron rammer were both tried, in the way of breaking through and penetrating chokes, but this method of attack was not found so satisfactory. The old cast-iron column pipe was made up of standard lengths of 9 feet each, with a few odd lengths and matching pieces. The upper portion weight of each length ranged from 31 hundredweight to 16 hundredweight, the average being a little over 1 ton. The wrought-iron strap plates connecting the wooden pump rods, ranged from $16\frac{1}{2}$ feet to 21 feet long and averaged about 6 hundredweight each. Each length of column pipe, as well as other heavy pieces of old ironwork, was raised through the shaft with the rider frame. Each length of pipe was slung on four short pieces of chain, the lower ends being bolted loosely to the upper flange of pipe, and the four pieces of chain were gathered together at the top by one large circular link, which was fastened by a shackle to the eye of the rope socket. The pieces of pump rod, $14" \times 14"$ pitch pine, cut into various lengths from 10 feet to 40 feet, were connected to the rope socket by means of a special large steel U-shaped clevis, a hole having been bored through each piece of timber to take the long bolt of the shackle. After having raised the old pit work to surface by means of a rope and rider frame, the doors over the skipway were closed and two small cars with swivel bolster and steel stanchions, were run on an 18-inch gauge track in the proper position to conveniently carry the material to be removed from the rope. The front

car would take the weight of the lower end of pipe or heavy timber, and as the rope was eased it would move forward, until the upper end of the material would gradually be let down into the second car. The iron chains, or special shackle, would then be unfastened, and the heavy material could be easily removed from over the shaft. The rider frame would either descend empty, or heavy shaft timbering could be sent down in it, or the skip could be attached and sent down for the usual work of clearing and repairing the shaft.

In the worst place of the shaft, that is, above the 212-fathom level, where the ground is badly disturbed by a cross-course, it was found advantageous to drive in a few rows of pointed iron rods from 5 feet to 9 feet long. Each row was put in just above the last easterly end piece of a timber set after it had been firmly secured. The rods were placed about 8 inches apart and driven in their full length, inclined slightly upwards. This method, together with ordinary wooden spiles driven down the sides as the choke was cleared, was found to answer very well, and prevented further heavy runs of loose ground into the shaft, as had occurred when the spiling method had been used without the addition of these iron rods. The object of using iron rods instead of ordinary wooden spiles was twofold; firstly, because the rods placed horizontally took up so little room, that the nearly vertical timber spiles could still be conveniently driven downwards between them; secondly, because wooden spiles were not strong enough for the work, and could not be successfully driven horizontally through the mixture of loose, decomposed granite containing hard boulders. At this part of the shaft every square foot of ground had to be carefully held by temporary timbering while preparing to put the permanent timbers in place. In a few places in the shaft it was found possible to make use of some of the old timber sets, usually about $9" \times 8"$ cross-section, also a little of the old lagging, but as a rule it was found to be broken or too rotted. For only short distances have the walls of the shaft been found sufficiently strong to stand safely without close lagging. A portion of the shaft at first appeared to be strong but after the water had been lowered and it had stood for some weeks or months exposed to the air, the walls began to crack and flake away badly, so that much of it had to be retimbered and closely lagged. The timbering is usually made up of $8" \times 8"$ sets with 2-inch lagging, but in places where the walls are fairly good, $6" \times 6"$ sets placed a little closer together have been used with $1\frac{1}{2}$ -inch lagging.

It may be interesting to note that a throttle valve on a pipe through the dam in the 75-fathom level was partly closed, and this caused rather curious results. The valve was partly closed and the water allowed to rise inside the dam to a height of about 92 feet, giving a pressure of about 40 pounds per square inch, which was as high a pressure as thought safe, until the concrete was sufficiently set. After the water under pressure had been running from the pipe for about 10 days, it was found that the cross-cut level, leading to the dam, contained a great quantity of carbon dioxide gas, which increased every day, and soon became so bad that it was impossible for a man to get in safely as far as the dam. A lighted candle would only burn within about 500 feet of the face, and acetylene lamps within about 300 feet. An air pipe line and ventilating fan were put in, and the bad air drawn out so that men could conveniently get in to the dam. It was found, after completely closing the valve and stopping the flow of water which had been spraying out from the mouth of the pipe with great force, that the quantity of carbon dioxide gas no longer increased. The condition remains the same to the present time, and there has never been any need to resort to artificial ventilation since the discharge pipe was closed. It therefore seems reasonable to suppose that the gas escaped from the water as the pressure was released, and while spraying out from the mouth of the pipe in the dam, the action being much the same as that of soda water in a bottle after the cork has been drawn and the pressure released. The carbon dioxide which was dissolved in the water under pressure may perhaps have

been picked up in old stopes, as the water rose against the roof. The author would be glad to hear if any one has had a similar experience, or from any one who can offer a better explanation of this rather peculiar occurrence.

Concerning the efficiency of the whole pumping plant, it may be said that when new and at full load the efficiencies were about as follows:

Engines and alternators, 86 per cent.; cables to pumps, 97 per cent.; motors of pumps, 91 per cent.; pumps, 72 per cent. Engine to pump delivery $.86 \times .97 \times .91 \times .72 = 55$ per cent.

The efficiencies of alternators, cables, and motors are practically unaffected by constant use, but wear and tear on steam

phosphor-bronze impellers and diffusion vanes, but it also is apt to throw the pump out of balance and cause serious trouble with the thrust bearings. It is important that the pump should be repaired before the shaft bushings and impeller rings become too much worn, otherwise the pump parts will be scoured and worn, and there will probably be trouble with the thrust bearing.

It should, perhaps, be mentioned that the mechanical engineer had had no previous experience with turbine pumps, and, under the existing conditions, feared to attempt making any repairs down in the shaft on the internal parts of the first two sinking pumps, also, on account of having to take them to surface for repairs, and the consequent loss of time, they were not

TABLE 1. SUMMARY OF PUMP CAMPAIGNS, APRIL 26, 1909—MARCH 3, 1911

Description of Pump	Number of Campaign	Reason of Stop	Period		Gallons Pumped	Length of Run	
			From	To		Hours	Minutes
No. 1 sinker.....	First	Failing duty	26-4-09	18-9-09	64,434,125	2,415	10
No. 2 sinker.....	First	Failing thrust bearing	23-9-09	14-2-10	95,895,358	3,001	35
No. 1 sinker.....	Second	Failing duty	17-2-10	13-6-10	*71,434,675	2,583	
No. 2 sinker.....	Second	Failing thrust bearing	16-6-10	10-10-10	*46,400,217	2,073	35
No. 1 station west.....	First	Thrust-bearing seizing	4-2-10	29-9-10	59,210,685	2,419	
No. 1 station east.....	First	General repair	25-4-10	19-11-10	90,259,195	3,405	
No. 1 sinker.....	Third	Failing duty and thrust seizing	14-10-10	4-3-11	*59,997,021	3,028	10

* NOTE.—Could not be obtained accurately, since exact measurements were only taken of all water delivered to adit.

engines and pumps affect their efficiencies considerably, if they are allowed to get out of repair. This is particularly the case with high-speed turbine pumps when pumping acid water full of gritty material. The parts of the pump most easily affected and which wear out soonest are the white-metal shaft bushings and impeller rings. The white-metal thrust bearings are also apt to heat up suddenly, due to temporary stoppage of the cooling water, or from some other cause. In this connection it has been found a good plan to arrange a little strainer and attach it to the water cooling pipe in such a way that it can be periodically cleaned, and thus lessen the danger of sudden chokeage and stoppage of circulating water round the thrust bearing. The phosphor-bronze impellers and guide vanes may occasionally become damaged after a very hard and rough campaign, but repairs and renewals in this respect are seldom required. The effect of acid gritty water passing through the body of the pump at a high velocity is to soften and wear away portions of the cast iron, so that the life of a cast-iron pump is very limited under these conditions. However, if a pump is required for long service, this difficulty can be overcome by making the body of gun metal instead of cast iron, at an extra cost of 20 per cent. more or less.

In the unwatering operations three sinking pumps and five station pumps have been in use, of which up to date never more than three have been working at the same time. The third sinking pump is the only one made with gun-metal body, but this, as well as the last two station pumps, is different from the first ones. The chief feature of the new type is the use of only one single diffusion vane for each impeller, instead of a series of diffusion vanes in the chamber for each impeller. The third sinking pump has also the advantage of being so constructed that each chamber and impeller can be easily removed or replaced. This is a great advantage, as the pump can be taken apart, impellers removed or added, and all ordinary repairs carried out down in the shaft, instead of having to raise the pump to the surface for repairs and alterations. Table 1 gives an idea of the work done by the first two sinking pumps and station pumps. Exact measurements were automatically taken of all water pumped to adit, but not of the quantities pumped by each pump to the 75-fathom level station, so that those figures preceded by an asterisk mark may only be considered as approximately correct. When the white-metal shaft bushings and impeller rings become worn, the water in the pump is able to pass in a wrong direction between the different chambers or stages of the pump. This leakage not only causes wear and tear to other parts than the

rebushed as often as they should have been. The third sinking pump is an improvement in this respect, and so far it has been possible to keep it in good repair without any long stoppage and without having had to bring it to surface.

With regard to the rate of progress, at one time for a period of 10 weeks an average speed of 5 feet a day was maintained while unwatering, clearing, securing, and equipping the shaft. On the other hand, three periods of 4 weeks each actually show losses. Slow progress was always due to one or more of the following causes:

1. Failing pump, and the time taken before the new pump was working satisfactorily in its place.
2. Extraordinary quantity of inflowing water due to exceptionally heavy rains.
3. Unforeseen delay in delivery of pumps at the mine.
4. Bad chokeages in the shaft.
5. Exceptionally bad condition of shaft walls.
6. Stoppage of machinery.
7. Removal from the shaft of extra heavy old pit work and interfering old timbers. Cutting out and preparing room for pump stations.

采 采

Chinese Laws Concerning Mine Accidents

The only legislation providing for the safety of mine employes in China of which the United States Consul General is aware is as follows:

Holders of permits must mark the boundaries of their concessions with stones so that their limits may be clearly shown. They must also adopt proper measures to guard against dangers, lest the engineers or workmen should meet with accidents. If in spite of the precautions taken any accident should occur, a report must be made as soon as possible to the local official, who will make an investigation. If any of the workmen shall have been killed, a satisfactory indemnity must be paid. The amount of the indemnity shall be determined by the circumstances, a generous allowance being made.

采 采

Asbestos is found in the Urals and the Governments of Perm, Kntais, Irkutsk, and Yeniseisk, but the yield of this mineral in the three last-named provinces does not comprise more than one-tenth of the quantity annually produced in the Ural Mountains. A recent Consular Report states that in 1910 there were 21 asbestos mines operating in the Urals and the total production was 24,406,776 pounds, a decline of 4,902,048 pounds as compared with the preceding year. The exports of this product in 1910 amounted to 17,712,000 pounds, valued at \$805,975.

Costs of Milling in Leadville

Machinery Required—Price of Electric Power and Resulting Cost of Treating Ore

By Oliver C. Ralston

The Leadville district mill, which is taken as an illustration for cost of milling, is a small concentrating plant designed to treat 100 tons of ore in a day of 24 hours. It is situated below the Rio Grande tracks, about 100 yards from the gate of the Arkansas Valley plant of the American Smelting and Refining Co. As it has been leased from time to time, and is now idle, it may be of interest to some one having a body of ore to be treated to know the approximate costs of operating.

As to machinery, the ore is unloaded from railroad cars over a 1½-inch grizzly through a 9"×12" Blake crusher into a storage bin running the length of the building. From the three gates of the bin Perfection ore feeders drop it on conveyor belts leading to coarse-crushing rolls 14 in. × 27 in., whence it is elevated to a set of four trommels of 6-, 8-, 12-, and 16-mesh, successively. The oversize from the first trommel is spouted to a set of fine rolls 14 in. × 27 in., and up the same elevator to the first trommel again.

The products from the trommels are treated in four jigs of the Hartz type, while the undersize from the first trommel is treated in a classifier and divided into four products and slimes, the four products being treated on four Card tables.

The Blake crusher is on an individual shaft driven by a 25-horsepower motor to allow running this section of the mill only in daytime, and storing up crushed product for 24 hours. The balance of the machinery, the rolls, trommels, jigs, tables, elevators, etc., are run from the main drive shaft with a 50-horsepower motor. Water is supplied from the creek by a 4-inch centrifugal pump driven at 500 revolutions a minute by a 10-horsepower motor with belt drive, supplying a tank near the top of the building. All motors are of General Electric make, 440 volts, 60 cycle, three-phase, induction.

The schedule of rates of the Leadville Light and Power Co., as taken from their contract, Form S, is as follows: A fixed charge per month per horsepower of maximum demand, and an energy charge on all energy used as shown by meter.

Fixed Charge Per Month Per Horsepower.—For the first 100 horsepower, \$3.25; for next 400 horsepower, \$2.25; for next 500 horsepower, \$1.75; for all additional horsepower, \$1.

Energy Charge.—Add for all energy used, as shown by meter, 13 mills per kilowatt hour for the first 40,000 kilowatt hours used per month, and 5 mills for all additional energy.

The company, in an estimate, took 125 horsepower for 24 hours as the basis of a bid and made an estimate of \$1,091.45 per month, or 1.6 cents per kilowatt hour.

The first 100 horsepower cost \$974; next 25 horsepower, \$117.45; total, \$1,091.45.

Additional figures which they use as a basis of figuring, and which may be of interest, are as follows: For motors delivered in Leadville: Motor, 5 horsepower, 1,200 revolutions per minute, Form K, 440 volts, \$116.10; motor, 10 horsepower, 900 revolutions per minute, Form K, 440 volts, \$242.90; motor, 25 horsepower, 720 revolutions per minute, Form K, 440 volts, \$417.10; motor, 35 horsepower, 720 revolutions per minute, Form K, 440 volts, \$473.25; motor, 50 horsepower, 514 revolutions per minute, Form K, 440 volts, \$734.30; motor, 50 horsepower, 900 revolutions per minute, Form K, 440 volts, \$494.95.

From the Power company's bid there is a fixed charge of \$1,091.45 per month, and if it is assumed that all 85-horsepower of the motors are being utilized for 24 hours, then 46,900 kilowatt hours of energy will be consumed, or \$5,545 energy charge, which in practice is reduced about one-third, as all the machinery is not going 24 hours. This leaves, fixed charge, \$1,091.45; energy charge, \$3,696; total power cost, \$4,787.45.

A power contract, for a maximum of 85 horsepower, would of course materially reduce the fixed charge.

The mill generally runs two shifts with:

One table, jig, and roll man	\$ 5 00
One helper	3 00
One laborer (loading concentrates)	3 50
Cost per shift	\$11 50, two shifts \$ 23 00
Unloading railroad cars two men for 10 hours, at \$2.50	5 00
Total labor costs per 24-hour day	\$ 28 00
Total labor costs per 30 days	\$840 00

The leases on the mill have been obtained in the past at a certain rate per ton of ore treated, with a certain minimum guarantee per month, and the terms depending on the length of lease and any other things that might come into consideration.

On custom work the price of treatment has ranged from \$1.25 to \$1.50 per ton, according to the nature of the ore. The concentrates are turned over to the owner again for shipment. At the present time no figures are available as to per cent. of recovery, but in the past it has ranged, with the ore, from 60 per cent. to 95 per cent.

來 來

Topographic Map of the United States

The United States Geological Survey is making a topographic map of the United States. This work has been in progress since 1882, and about three-tenths of the area of the country, excluding outlying possessions, has been mapped. The mapping areas are widely scattered, nearly every state being represented, as shown on the progress maps accompanying each annual report of the director.

This great map is being published in atlas sheets of convenient size, which are bounded by parallels and meridians. The four-cornered division of land corresponding to an atlas sheet is called a quadrangle. The sheets are of approximately the same size: the paper dimensions are 20 in. × 16½ in.; the map occupies about 17½ inches of height and 11½ to 16 inches of width, the latter varying with latitude. Three scales, however, are employed. The largest scale is 1 : 62500, or very nearly 1 mile to 1 inch; that is, 1 linear mile on the ground is represented by 1 linear inch on the map. This scale is used for the thickly settled, or industrially important parts of the country. For the greater part of the country an intermediate scale of 1 : 125000, or about 2 miles to 1 inch, is employed. A third and still smaller scale of 1 : 250000, or about 4 miles to 1 inch, has been used in the desert regions of the Far West. A few special maps on larger scales are made of limited areas in mining districts. The sheets on the largest scale cover 15 minutes of latitude by 15 minutes of longitude; those on the intermediate scale, 30 minutes of latitude by 30 minutes of longitude; and those on the smallest scale, 1 degree of latitude by 1 degree of longitude.

The features shown on this map may, for convenience, be classed in three groups: (1) Water, including seas, lakes, ponds, rivers, and other streams, canals, swamps, etc.; (2) relief, including mountains, hills, valleys, cliffs, etc.; (3) culture, that is, works of man, such as towns, cities, roads, railroads, boundaries, etc. The conventional signs used for these features are grouped below the maps. Variations appear in some maps of earlier dates.

All water features are shown in blue, the smaller streams and canals in full blue lines, and the larger streams, lakes, and the sea by blue water lining. Certain streams, however, which flow during only a part of the year, their beds being dry at other times, are shown, not by full lines, but by lines of dots and dashes. Ponds which are dry during a part of the year are shown by oblique parallel lines. Salt-water marshes are shown by horizontal ruling interspersed with tufts of blue, and fresh-water marshes and swamps by blue tufts with broken horizontal lines.

Relief is shown by contour lines in brown. Each contour passes through points which have the same altitude. One who follows a contour on the ground will go neither up hill nor down hill, but on a level. By the use of contours not only are the shapes of the plains, hills, and mountains shown, but also the elevations.

The line of the seacoast itself is a contour line, the datum or zero of elevation being mean sea level. The contour line at, say, 20 feet above sea level is the line that would be the seacoast if the sea were to rise or the land to sink 20 feet. Such a line runs back up the valleys and forward around the points of hills and spurs. On a gentle slope this contour line is far from the present coast line, while on a steep slope it is near it. Thus, a succession of these contour lines far apart on the map indicates a gentle slope; if close together, a steep slope; and if the contours run together in one line, as if each were vertically under the one above it, they indicate a cliff.

In many parts of the country are depressions or hollows with no outlets. The contours of course surround these, just as they surround hills. Those small hollows known as sinks are usually indicated by hachures, or short dashes, on the inside of the curve. The contour interval, or the vertical distance in feet between one contour and the next, is stated at the bottom of each map. This interval varies according to the character of the area mapped; in a flat country it may be as small as 10 feet; in a mountainous region it may be 200 feet. Certain contours, usually every fifth one, are accompanied by figures stating elevation above sea level. The heights of many definite points, such as road corners, railroad crossings, railroad stations, summits, water surfaces, triangulation stations, and bench marks, are also given.

The sheets composing the topographic atlas are designated by the name of a principal town or of some prominent natural feature within the district, and the names of adjoining published sheets are printed on the margins. The sheets are sold at 5 cents each when fewer than 100 copies are purchased, but when they are ordered in lots of 100 or more copies, whether of the same sheet or of different sheets, the price is 3 cents each.

The topographic map is the base on which the facts of geology and the mineral resources of a quadrangle are represented. The topographic and geologic maps of a quadrangle are finally bound together, accompanied by a description of the district, to form a folio of the Geologic Atlas of the United States. The folios are

sold at 25 cents each, except such as are unusually comprehensive, which are priced accordingly.

Applications for the separate topographic maps or for folios of the Geologic Atlas should be accompanied by the cash or by post-office money order (not postage stamps), and should be addressed to The Director, United States Geological Survey, Washington, D. C.

采 采

Wooden-Stave Water Pipe

Illustrations of Use of Large-Diameter Wooden Pipes for Carrying Water for Power Purposes

By Frank C. Perkins

Owing to the advantages to be derived from the use of wooden-stave pipes a number of power plants have been equipped with them during the past decade. Originally, wooden pipes were bound with flat bands of iron that answered every purpose for low water heads; this method of strengthening the wooden staves soon gave way, however, to round bands. It is practicable to make wooden-stave pipes for any desired head by increasing the number of bands and then they may become more costly than iron or steel pipes. One material advantage the wooden-stave pipe has over iron or steel pipe is that it may be made to conform to the irregularities of the ground more readily. Other advantages are that when laid on the surface it will not corrode or collapse so readily.

Fig. 1 shows another installation of a 48-inch continuous-in diameter, that is utilized for carrying water to a turbine water-wheel in a flour mill at Pendleton, Ore.

In Fig. 2 is shown a continuous wooden-stave, 86 inches in diameter, fir pipe more than 5 miles in length, which conducts water to the power station where current is generated for operating the electric light and street railways in the city of Walla

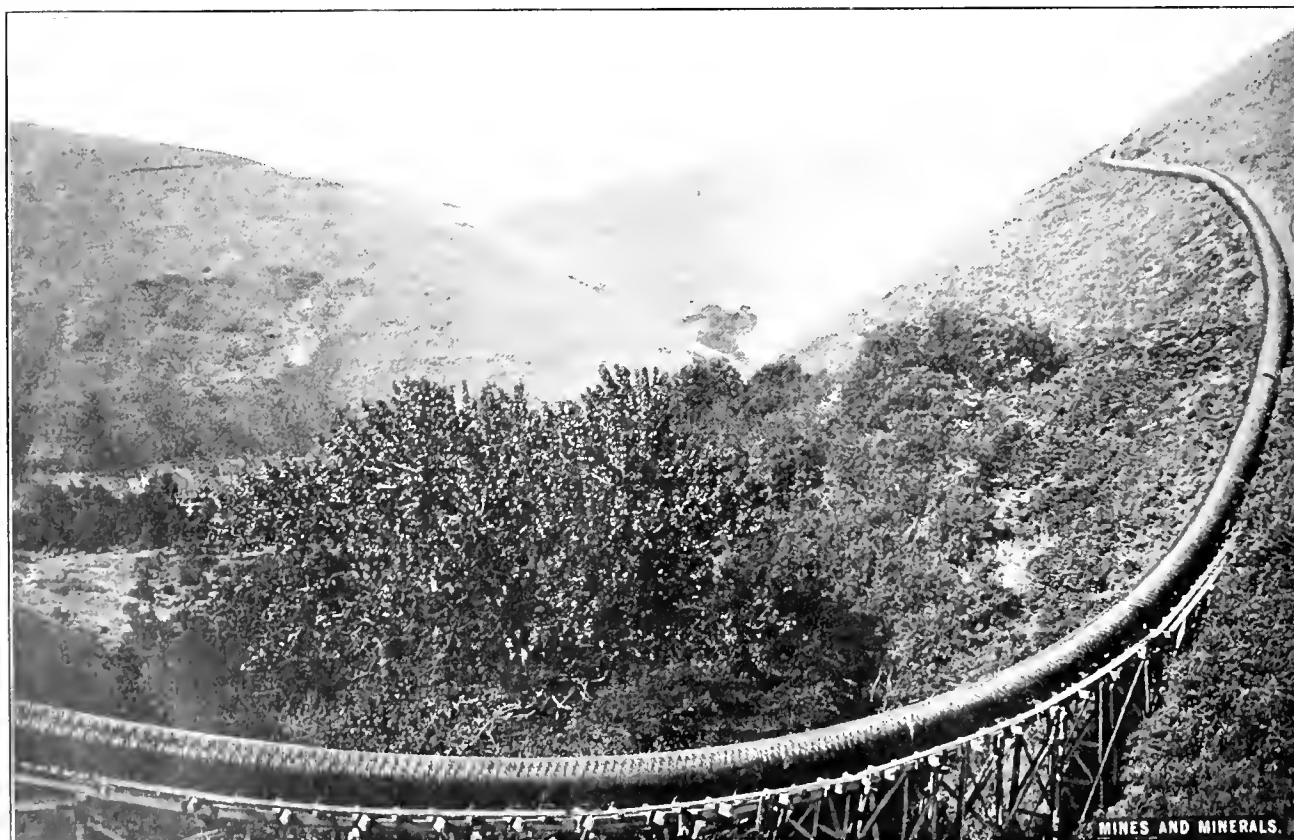

FIG. 1. CONTINUOUS WOODEN-STAVE PIPE, 5 MILES LONG, 48 INCHES DIAMETER

Walla, Wash. This pipe has its lowest point on the trestle shown in the foreground where it is under a 300-foot head, equivalent to 130 pounds pressure per square inch.

A remarkable incident in connection with this pipe is of special interest from the fact that the trestle was carried away

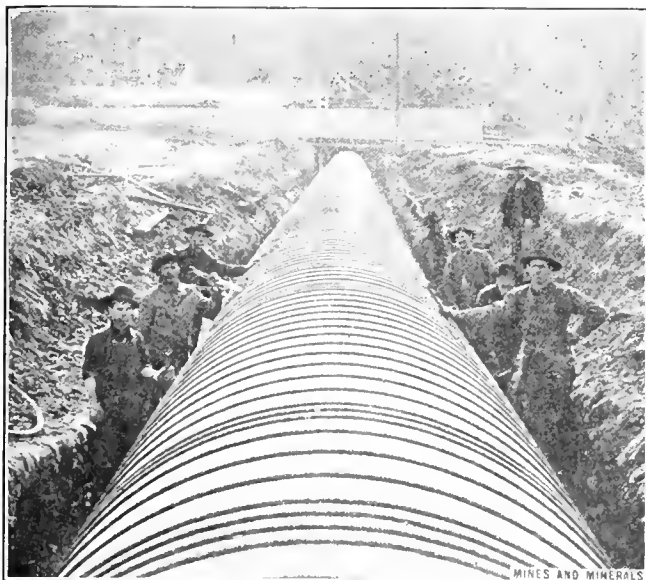

FIG. 2. WOODEN-STAVE PIPE, 56 INCHES DIAMETER

during a freshet leaving the pipe suspended in mid-air for a span of 60 feet without injury to the pipe and without leakage of water. Of course, this would have been impossible with steel or cast-iron pipe on account of the great weight of the latter compared with the continuous-stave pipe.

For pumping service the stave pipe has also been utilized to advantage, it being particularly valuable where the pipe lines pass along electric railways, as there is no danger of deterioration due to electrolysis; also when the water from a mine is acid and will corrode iron or steel pipe. In the latter case the bands must be kept coated with asphalt paint, but in case one or more should corrode they can be replaced and by this means keep the pipe in order.

Wooden-stave pipes are fitted with cast-iron Y's, bends, valves, etc., as shown in Fig. 3, which is taken from a photograph of a by-pass and pressure regulator on the McMinnville, Oregon, waterworks. More than one placer mine has been worked by water carried through wooden-stave pipes.

來 來

Tennessee Phosphate Rocks

There are at present seven producing phosphate states in the United States. They are Florida, Tennessee, South Carolina, Arkansas, Idaho, Wyoming, and Utah; the last three being the largest and most extensive. It is thought that the deposits of France and Belgium, which are the largest producing phosphate fields except Tunis and the United States, have been practically exhausted. The South Carolina field has been reduced to the low-grade rock, while Florida and Tennessee have obtained their maximum production. The Arkansas field is of low grade and freight rates will probably prevent extensive developments of the important field in southwest Idaho, Utah, and Wyoming in the near future. Mining in the brown rock strata of Tennessee, which runs from 30 to 60 inches in thickness, is all surface mining, the overburden ranging from a few inches to 15 feet.

Mining in the blue rock strata which runs from 20 to 48 inches in thickness is all underground work and conducted by tunneling. The cost of mining the blue rock is about 30 cents per ton more than the cost for mining the brown rock on account of the powder

and dynamite necessary to be used. The entire marketed product is now cleaned and washed by machinery before drying, which not only saves a large quantity of rock heretofore wasted but gives to the trade a rock with a higher grade of brown phosphate of lime and makes the entire brown rock field practically an export product.

The analyses show the white rock found in Decatur County to carry from 68 to 74 per cent. bone phosphate of lime with about 3 per cent. iron. Analyses of the white rock in Perry County run from 78 to 83 per cent. bone phosphate of lime and less than 3 per cent. of iron. Analyses of the blue rock found in Hickman, Lawrence, Lewis, and Maury counties average about as follows: Bone phosphate of lime (calcium phosphate), 68 to 78 per cent.; iron and alumina, 2 to 4 per cent.; moisture, 0 to 3 per cent.

Analyses of the brown rock in Maury county, sold for domestic purposes, average as follows: Bone phosphate of lime, 70 to 78 per cent.; iron and alumina, 2.75 to 7 per cent.; moisture, .05 to 3 per cent.

Analyses of brown rock in Maury county sold for export purposes are as follows: Bone phosphate of lime (calcium phosphate), 78 to 82 per cent.; iron and alumina, 2.75 to 7 per cent.; moisture, .05 to 2 per cent.

The low iron and alumina in the blue rock more than offset the low content of bone phosphate of lime in the brown rock and place it in direct competition with the brown rock sold for domestic and export purposes.

The following simple test for phosphate rock is given by F. B. Van Horn of the United States Geological Survey: Place a small crystal of ammonium molybdate on the rock to be tested, then drop a little dilute nitric acid on the crystal. If the crystal turns yellow it indicates the presence of phosphorus. The deeper the yellow the higher the phosphate it contains. Another test is to finely pulverize the rock to be tested. Place a little of it in a test tube, add about 3 cubic centimeters of warm nitric acid and let it dissolve as much as possible of the rock. Pour a few drops of the solution obtained into another test tube containing about 5 cubic centimeters of ammonium molybdate. If



FIG. 3. IRON VALVES, BY-PASS AND PRESSURE REGULATOR ON WOODEN PIPE

after standing a few minutes a yellow precipitate makes its appearance phosphorus is present in the rock. This will be found a good confirmatory test. In 1910 Tennessee produced 398,188 long tons of phosphate rock, valued at \$1,503,350. The price per ton was, brown rock, \$3.83, blue rock, \$4.12. Tennessee furnished 15 per cent. of the production in the United States.

Treating Copper Anode Residues

Analyses of Cathodes and Residues—Fusing Methods—Direct Sulphuric Acid Treatment

Copper-anode sludge, or tank residue, is formed during the electrolytic refining of blister copper and is the result of the oxidation of the anode by the current entering the electrolyte. It consists mainly of the associated impurities which stand lower in the electromotive force series than the metal which is being refined. The following analysis is of an average cathode produced at one of the Montana electrolytic refineries at a current density of 35 amperes per square foot:

Copper, 99.66 per cent.; arsenic, .0020 per cent.; antimony, .0025 per cent.; iron, .0040 per cent.; bismuth, .0004 per cent.; selenium, .0009 per cent.; tellurium, trace; silver, .0035 per cent.

The analysis does not foot up to 100, the difference being due to oxygen principally. The anode from which this refined copper was obtained produced a sludge having about the following composition:

Silver, 40 per cent. or 12,000 Troy ounces; gold, 2 per cent. or 600 Troy ounces; copper, 25 per cent.; selenium and tellurium, 5 per cent.; arsenic and antimony, 10 per cent.; lead, iron, and bismuth sulphates, 18 per cent. The reason that lead and bismuth sulphates predominate over the oxides in copper-anode sludge, is due to the minimum electromotive force of lead and bismuth being above that of copper, and these elements being dissolved with the copper they form stable sulphates with the acid in the electrolyte, and precipitate in the refining tank. The residue, or precipitate formed in the bottom of the refining tank,

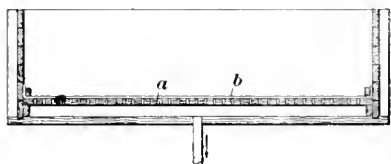

FIG. 1

contains practically all the silver and gold that was in the anode together with lead, arsenic, tellurium, selenium, iron, bismuth, antimony, zinc, and some copper compounds and fragments of copper from the disintegrated anode. The residue is treated for gold, silver, and copper, and until recently it was the custom to waste the other products; now, however, the selenium and tellurium are being saved and stored in anticipation of the growing demand for these elements. After anode residue has been removed from the precipitating tank it is poured over a 16-mesh copper screen upon which the scrap copper, often amounting to a considerable quantity, is separated from the fine materials. The coarse copper is washed and returned to the anode furnace for remelting.

The material that passes through the screen is placed in a filter tank similar to that shown in Fig. 1 which has a perforated false bottom *a* upon which a flannel, or heavy cotton cloth *b* is stretched. Owing to the thick and slimy consistency of the residue it is necessary to employ some kind of a vacuum pump to draw off the solution remaining and the wash water that follows. The filtrate is usually returned to the tanks holding the electrolyte, and the wash water used after the electrolyte has been drawn is thrown away.

Some refiners make use of filter presses to separate the electrolyte from the slime and to perform the washing operation; in either case after washing to remove soluble compounds the slime is placed in a sheet-iron pan and dried in an oven. When dry it is sampled for assaying and then treated for the metals it contains by one of several processes.

Thofehrn's process consists in oxidizing the dried slime by exposing it to the atmosphere for a time; then, to free it from

the base metal oxides formed, it is melted in a magnesite lined reverberatory furnace. The fusion produces a copper matte which contains all the gold and silver. The matte is treated by electrolysis, the cathode copper being sufficiently pure to melt, pour into molds, and send to market. The residue from this treatment is rich enough in gold and silver to be subjected to the concentrated sulphuric acid process.

Another fusion method of treating copper-anode residue, is to mix the material when dried with sodium carbonate and potassium nitrate and melt in a reverberatory furnace lined with magnesia brick. The melting produces a slag which contains antimony, arsenic, selenium, tellurium, some silver and most of the copper and bismuth. The slag is sent to the blast furnace and added to the regular charge. The base bullion on the hearth of the reverberatory contains gold, silver, copper, and lead, and after skimming off the scoria, it is cast into suitable plates and parted with hot concentrated sulphuric acid or by electrolysis.

In the Cabell-Whitehead process the tank residue is treated with sulphuric acid and silver sulphate. An interchange of metals occurs between the copper and the silver, the copper in the slime being dissolved and the silver precipitated. The silver thus obtained is washed free from copper sulphate and melted into bars. The reactions which occur are as follows:

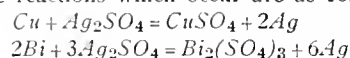

In the case of the bismuth and antimony, their sulphates are decomposed, and form insoluble basic sulphates. The use of silver sulphate residue from the sulphuric-acid parting kettle for doré bullion reduces the time of treatment 6 to 8 hours. This residue consists principally of anhydrous silver sulphate and copper sulphate which form on the side of the kettle during the parting of doré bullion.

Direct treatment with hot concentrated sulphuric acid is not much used, owing to the loss in acid by the formation of sulphur dioxide. It consists, however, in treating the dried tank residue with hot sulphuric acid in iron kettles to dissolve any copper or silver it contains. The gold remains as a brown slime unaffected by the acid. The silver in solution is precipitated on copper plates, the copper sulphate formed being saved later by crystallization from the liquor. Direct treatment is not suited to slime containing much arsenic or antimony as they are converted into insoluble oxides.

What is termed the direct treatment with dilute sulphuric acid and air, consists in placing the washed copper-anode residue in a lead-lined tank, in the bottom of which is a perforated lead pipe, connected with a steam pipe and a Körtling injector, having a short inner tube and an air opening. One part sulphuric acid and two parts water are added to the residue and the mass is then boiled and agitated by means of the steam admitted through the pipe and injector. The operation, which occupies from 25 to 30 hours, is said to be quickened by the addition of small quantities of potassium nitrate as an oxidizer to ferrous salts.

In this process the hot acid dissolves the copper and at the same time liberates sulphur dioxide SO_2 . However, this is not lost, as in the direct concentrated sulphuric acid process, for it unites with the copper sulphate CuSO_4 present forming cuprous sulphate. At the same time any sulphur trioxide SO_3 formed unites with water to form sulphuric acid. The oxygen from the air immediately reoxidizes the cuprous sulphate to cupric sulphate. These reactions free the residue from copper and make it proportionally richer in silver and gold. Any silver in solution may be precipitated by suspending strips of copper in the tank just previous to collecting the residue on a filter and washing it until free from traces of copper sulphate. The solution and wash water are used in the preparation of a new electrolyte or otherwise worked for the copper they contain. The rich slime, now freed from copper, is dried and melted at a low red heat; during this operation the arsenic and antimony are volatilized in an oxidizing flame, and after the base bullion has been poured into suitable molds it is ready for parting. If the filtrate

resulting from the dilute sulphuric acid process is to be worked for the sulphates $CuSO_4$, $FeSO_4$, $Sb_2(SO_4)_3$, $Bi_2(SO_4)_3$, and other compounds, it is evaporated to crystallization in lead pans heated by steam coils. Two products will be obtained: "Commercial bluestone," or copper sulphate $CuSO_4 \cdot 5H_2O$, and impure "bluestone," the quantity of the latter depending on the quantity of ferrous sulphate and other impurities in the solution. Ferrous and cupric sulphate are isomorphous, crystallize together, and can only be separated by converting the ferrous into ferric sulphate by nitric acid, or the addition of potassium nitrate KNO_3 .

The mother liquor siphoned from the first crystallization tank is evaporated a second time to crystallization and a second crop of "bluestone" for market, and an impure "bluestone," are obtained. The impure bluestone from the two evaporation processes is dissolved in water and evaporated as before, thus obtaining pure and impure crystals. The mother liquor from the second treatment is siphoned from the tank and evaporated until sulphur dioxide fumes are evolved after which it is allowed to cool. The liquor left is crude sulphuric acid, while the residue contains oxides from which arsenic, antimony, and bismuth may be obtained. The residue from the dilute sulphuric-acid process consists of insoluble sulphates and the silver, gold, tellurium, selenium, and some sulphur. This residue is washed, dried, smelted with one-fifth its weight of potassium nitrate in a basic lined furnace to base bullion. The base bullion contains all the silver, gold, lead, bismuth, and copper with a trace of selenium and tellurium, while the slag contains the larger part of the impurities that existed in the slime before melting. The slag is returned to the blast furnace and the bullion after being cast into plates is parted by hot sulphuric acid or by electrolysis.

采 采

Petrolia, Henrietta, and Electra Oil Fields

The University Bureau of Economic Geology and Technology, Austin, Tex., has undertaken to make an examination of the oil and gas regions in Clay and Wichita counties, on the Red River, northwest of Fort Worth. The field work is in charge of Dr. J. A. Udden, geologist for the Bureau, who began his studies there early last October.

No published reports on this area have ever been made, as there is no geological survey in Texas, and it is only recently that funds could be provided by the University. There are now two recognized oil fields in this region—Petrolia, in Clay County, sometimes known as the Henrietta field, and Electra, in Wichita County. There is also in Clay County the largest natural gas field now known in Texas, supplying the cities and towns of Fort Worth, Dallas, Wichita Falls, Henrietta, Byers, Petrolia, Bellevue, Bowie, Sunset, Alvord, Decatur, Bridgeport, Rome, Irving, etc.

About the first of this year the Lone Star Gas Co., Fort Worth, had the following pipe lines in operation: 125 miles of 16-inch, 4 miles of 12-inch, 5 miles of 6-inch, 40 miles of 4-inch, 6 miles of 3-inch, 16 miles of 2-inch, or a total of 196 miles of pipe. Since that time the service has been extended, and it is likely that further additions will be made.

The Henrietta oil field, Clay County, became a regular producer in 1904. From this time to the close of 1910 it had produced 657,858 barrels of oil. During the year 1910 this oil sold for about 52 cents per barrel of 42 gallons, but recent contracts have been made at 55 cents. The oil is classed as light oil.

It is likely that the cheapest natural gas in the world can now be obtained at Wichita Falls, as it is stated that it will be supplied to responsible manufacturing establishments at 1½ cents per thousand cubic feet. This flourishing town has had 6- and 7-cent gas for some time, but the reduction to 1½ cents breaks all known records.

An interesting matter in connection with the oil and gas developments in this region is the possibility of utilizing the

copper ore that occurs in that part of the state, in the counties of Archer, Baylor, Knox, Wilbarger, etc. The lack of cheap fuel has been among the reasons that have prevented the utilization of these deposits of copper ore, but it would now appear to be feasible to assemble these ores at Wichita Falls and make use of the oil and gas for the production of copper matte. Some of these ores carry nearly 60 per cent. of copper and lie within a few miles of railroad transportation.

采 采

Concrete Balance Rest

In the construction of a balance table, solidity is the main feature. This is necessary to free the balance or other delicate instruments from the vibrations of the building caused by winds and other conditions. Vibrations of the earth cannot be avoided and if the laboratory is near a railroad track, bridge, or factory where heavy machinery is in operation, no amount of solid foundation will free the table from vibrations.

It is the general practice to sink heavy pillars of wood or concrete into the earth and build the table on these; another practice is to put in a concrete base the full size of the table and fasten a heavy wooden table to this foundation by means of bolts. These tables are both efficient and accomplish their purpose in a satisfactory manner; however, at the Butte School of Mines balance tables have been constructed on a plan which has special advantages.

A concrete pillar *a* is built to about one-half inch above the level of the table for the balance to rest on. The table *b* is built

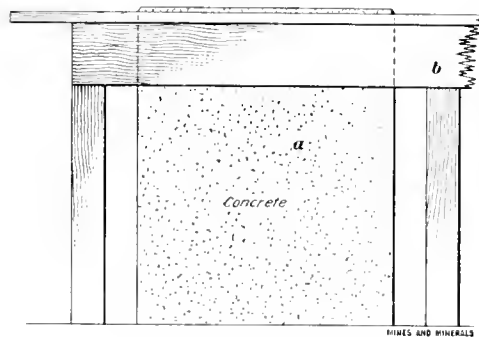

FIG. 2. CONCRETE BALANCE REST

around the pillar, but does not touch it—neither does the floor of the building. The pillar is free, therefore, from any vibrations, from these sources. The table can be built of lighter materials than in either of the two constructions referred to above and has the advantage of having only one small pillar to each balance. It also has the advantage that the balance sets directly on the concrete pillar with no intervening wooden table or table top.

采 采

Manufacture of Oxygen

Oxygen is extensively manufactured in Great Britain for mechanical purposes. The London *Times* states that when the factory now building in Sheffield is completed the company owning it will possess eight factories in the United Kingdom, all situated in centers where the demand for oxygen is important—at London (Westminster and Greenwich), Birmingham, Cardiff, Manchester, Sheffield, Newcastle, and Glasgow. These extensions are entirely due to the demand for cheap oxygen in connection with oxyacetylene welding and oxygen metal cutting. They are of liquid-air type, producing oxygen of a high degree of purity, and when the Sheffield plant is in operation their total output will be about 300,000 cubic feet a day. The present average price of oxygen, supplied in cylinders, for industrial purposes is about £2 (\$9.73) per 1,000 cubic feet, but reductions are expected if the demand increases.

Shaft Sinking by Electric Sinking Hoists

Equipment at the Shaft of the Cinderella Consolidated Gold Mining Co. Ltd., at Boksburg

The following article describing the use of electricity in shaft sinking in South Africa recently appeared in the *South African Mining Journal*:

The use of electricity for driving main shaft winding engines created a new problem in connection with the sinking of shafts. Formerly the practice, both in this country and abroad, was to sink shafts and carry them down to considerable depths by means of a special head-gear and a pair of small engines. With the advent of the electric winding engine, however, coupled with the practice of purchasing power from a supply company, it is no longer convenient to install temporarily a steam winder and boiler plant. The sinking of a large shaft usually occupies a period of from two to three years, or even longer. It is therefore, scarcely permissible to install immediately the winding engine for the full contemplated output of the mine, because in addition to the loss on the capital involved, a serious loss is incurred on account of the low efficiency of large hoists when operating at speeds and outputs much below their rated capacity. One solution of the problem, which appears to be an eminently satisfactory one, is that furnished by the electric sinking equipment at the central shaft of the Cinderella Consolidated Gold Mining Co., Ltd., at Boksburg. When finished, the approximate dimensions of the shaft will be 43 feet 6 inches wide, 7 feet 6 inches long, and 3,000 feet deep, divided into six hoisting compartments and one pipe-and-ladder way. The first work carried out at this shaft was to sink for some 10 to 12 feet by means of portable steam cranes, and then to install the collar set. As soon as this was done, the final head-gear was erected, but with four light sheaves over four compartments, and at the same time two double-drum electric sinking hoists were erected in a temporary engine-house located between the headgear and the projected site of the main winding engines. The following details of the hoists and their service have been published: Drums: Two per hoist, 8 feet diameter, 2 feet 3 inches wide. Brakes: Hand-operated post brakes on each drum. Foot-operated band brake on first-motion shaft. Gearing: Double reduction. First-motion, double helical power-plant steel gear. Second-motion, machine-molded cast-iron gear. Depth indicators: Dial type, without overwinding attachment. Mine shaft: Vertical, final depth 3,000 feet. Load: 3,000 pounds of rock. Skip: 2,500 pounds. Rope: 1 inch diameter, 4,500 pounds. Hoisting speed: 1,000 feet per minute. Each hoist is driven through an elastic coupling by a 180 b. h. p., three-phase, 50-period, 500-volt, Westinghouse, type A. I. F., slip-ring induction motor, capable of carrying a load of 450 b. h. p. for short periods. Power is obtained from the high-tension lines of the Victoria Falls and Transvaal Power Co., Ltd., and transformed to 500 volts for the hoists and auxiliary apparatus. The control of the hoists is effected by standard Westinghouse liquid controllers. By means of these controllers the hoists are stopped, started, and reversed at any speed from zero to full speed in either direction. A main switchboard of three panels is supplied. The sinking of this shaft in common with many others, entails a good deal of blasting. Should the supply of electric power cease whilst the sinker is starting a blast, his means of escape would be cut off, with almost certain death as the result. This power storage set consists of (a) an exciter, (b) a synchronous motor, which may act as a generator, (c) a heavy flywheel running in heavy bearings with forced lubrication, and (d) a starting motor for bringing the synchronous motor up to full speed. The synchronous motor is connected directly to the line, and automatic devices are arranged so that a failure of the power supply causes the main circuit to be interrupted. The power for driving the hoist is then derived from the flywheel until power supply is restored. In this case the generator is of the 150-kilowatt capacity, running at 750 revolutions per minute, and the flywheel in slowing to 375 revolutions per minute gives out sufficient energy

to run the set light for five minutes and then hoist a load of 700 pounds in the skip through a distance of 400 feet, bringing the sinker out of danger. The power-storage set is only in operation during the blasting period, and seldom for more than half an hour at a time, three times in 24 hours. The manner in which it is operated is as follows: When all the shot holes are drilled the shaft is emptied of workmen and the sinker descends to charge the holes. About 15 minutes before he is ready to light the fuses, the sinker sends a special signal to start the power storage set. Another signal is sent as soon as he is ready to fire the charges, and the engine driver raises and lowers the skip about two feet to show that all is right. The sinker then lights the fuses, gives the hoist-away signal, and is carried out of danger whether the power supply has failed or not. The value of the power-storage set is shown by the log kept on the mine. It is recorded that in five months seven interruptions occurred, one being during blasting, yet in every case the skip has been brought to safety. The value of this feature cannot be exaggerated, while the knowledge that their lives are adequately safeguarded inspires the men with an easy confidence in working which more than compensates for the cost of installation. These interruptions of power are due, of course, to the great difficulties under which the Victoria Falls and Transvaal Power Co.'s stations operate, for there are few places in which thunder storms are so violent and so frequent. These difficulties would not be experienced to such a degree in countries having a more equable climate. A record of the distance sunk with the equipment up to May 31, 1911, has been kept and is given here:

Month	Feet Sunk	Cost of Electric Power for Hoists		
		£	s	d
December, 1910	66			
January, 1911	142	54	6	
February, 1911	84	31	2	4
March, 1911	75	32	2	4
April, 1911	116	58	13	5
May, 1911	153	80		

The cost of power varies, but averages 0.585*d*. The cost of the two hoists and flywheel set delivered in South Africa, but not including erection or cables, was approximately £5,000. Records show that the cost of sinking 148 feet with a steam sinking hoist was approximately £178 for power under conditions similar to those in which 142 feet were sunk by the electric hoists at a cost of £54 6*s*. This means a saving of 16*s*. per foot in power alone. In addition to this, it is estimated that there is a further saving of £1 per foot due to the delicate control of the electric hoists which enables them to carry out maneuvers impossible to a steam hoist. On this basis the hoists and power-storage sets will pay for themselves before the shaft is completed, and even then would possess considerable value at second hand, as such hoists are by no means worn out in three years. Messrs. E. Farrar and J. N. Bulkley, consulting engineers to the General Mining and Finance Corporation, have kindly permitted the publication of the figures taken from their log books.

來 來

Enforced Annual Assessment Work

In the case of unpatented claims a remedy should be sought for what has been termed "the paralysis of mining districts," and the rigid requirement of annual assessment work should be made actual and effective by inspection and supervision, in order to put an end to the present procedure of allowing a claim to lie idle for practically two years after its location, not to mention the many localities where claims are held year after year with only perfunctory compliance, or even without any performance of assessment work—a type of local disregard for law that is striking in contrast to the observations accorded to the district customs and regulations of earlier days, whereby the right of possession was made absolutely dependent upon continuous operation.—Geo. Otis Smith

Descriptive Mineralogy of Mica

Different Varieties of Mica, and Variations in Structure That Influence Values

By Douglas B. Sterrett

The following is taken from Economic Paper No. 23 of the North Carolina Geological Survey: Of the numerous varieties of mica there are but four that have commercial value. These are muscovite, $H_2Al_2Si_2O_8$; phlogopite, $K_2Mg_6Al_2Si_7O_{20}$; biotite, $K_2(FeMg)_7Al_8Si_7O_{28}$; and lepidolite, $(KLi)_6Al_8Si_{12}O_{39}$. Muscovite and phlogopite have a wide application in both sheet and ground form. Biotite has only recently been used in the ground form. Lepidolite is used as a source of lithia salts and to a small extent for ornamental purposes. Muscovite is the only mica that has been mined extensively in North Carolina, and it is only within two years that a small demand has arisen for biotite for grinding.

Muscovite has a hardness of 2.5 and a specific gravity of 2.8-3. Like all the micas, it belongs to the monoclinic system of crystallization and has a symmetry approximating the hexagonal.

Mica mined for commercial purposes is generally found in rough blocks, sometimes with an irregular development of crystal faces. The faces are not usually as many as would be required to complete the simplest figure, and their surfaces are generally rough. Commonly a large part, if not all, of a block of mica has a ragged outline without plane surfaces. Occasionally fairly developed hexagonal or rhombic prisms are observed in large crystals of mica.

Rough crystals, or "books" of mica, do not split perfectly until the outer shell of etched and sometimes partly crushed mica has been removed. This is accomplished by rough splitting or cleaving the large book into sheets one-eighth inch thick or less and trimming the edges with a knife held at a small angle with the cleavage. Further splitting is then easy, because the cleavage of mica is so perfect and the tangled outside edges of the sheets have been removed. By grinding a wedge edge on the sheets and using a thin sharp knife mica can be readily split into sheets as thin as .001 of an inch or thinner.

A percussion figure is formed by three cracks or cleavages in a plate of mica crossing at a common point and making angles of approximately 60 degrees with one another, commonly described as a six-rayed star. It may be produced by striking a sheet of mica a sharp blow with a pointed punch or thrusting the punch through the sheet. The same thing is produced occasionally on a large scale in a mine by a miner unintentionally striking the cleavage face of a block of mica with a pick. One of the rays, sometimes noticeably more prominent than the other two, corresponds in direction with the front axis of a mica crystal. The other two rays are parallel to the prism faces m , shown in Fig. 1, at 1, 2, 3, 5, 6, 7.

A pressure figure is similar in appearance to the percussion figure, but oriented with its rays at angles of about 30 degrees with those of the percussion figure. The pressure figure is seldom obtained with the same symmetrical, perfect development as the percussion figure and is often very difficult to obtain. By pressing with a punch against a sheet, one or more rays of the pressure figure may be produced, and if the punch is then thrust through the sheet a percussion figure will also be formed and the two may be seen with their approximate 30 degree relation to each other.

Mica has a number of physical peculiarities which give rise to different trade names and descriptive terms used by the miners. These are due to crystal structure, color, and inclusions. Structural peculiarities give "ruled" or "ribbon," "wedge," "A," "hair-lined," "fish bone" or "herring bone," and "tangle-sheet" mica. Trade names for different colors of mica are "rum,"

"ruby," "amber," "white," and "black." Brown, green, and greenish-brown colors also occur in mica. Certain inclusions give "specked" and "clay-stained" mica.

"Ruled" or "ribbon" mica is formed by more or less clean, sharp parting planes cutting through the mica crystals and making an angle of a little more than 60 degrees with the base or cleavage surface. This parting passes entirely through some crystals and in others extends only part way across the face or does not cut through the entire thickness, as shown at 1. The trace of the ruling planes corresponds in direction to the rays of the pressure figure in mica. Though a cleavage resembling ruling may be produced by making a series of percussion figures along the line of one of the rays, it is evident that "ruling" planes do not correspond to the lines of weakness represented by the percussion figure, for the two make angles of about 30 degrees with each other. On the other hand, the ruling planes fall in the same direction as the rays of the pressure

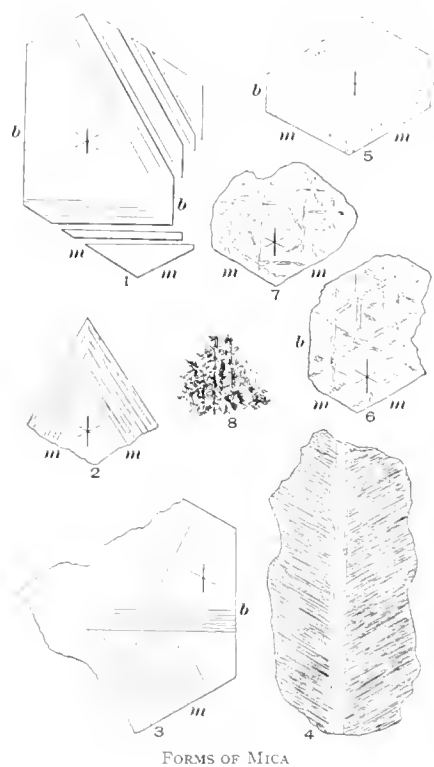

figure and probably occur along the lines of weakness represented by them.

"Ruling" lines occur more commonly in one series of parallel lines in mica. In some specimens these parting planes are present in two or even three directions, and their traces on the cleavage planes make angles of about 60 degrees with one another, dividing the mica sheets up into small triangular plates. The value of large blocks or crystals of mica, otherwise of excellent quality, is sometimes rendered small or practically nothing by the presence of many "ruled" lines.

In "wedge" mica the crystals are thicker on one side than on the other. The difference in thickness on opposite edges may be greater than half an inch in some crystals 3 inches in diameter. This structure is due to an unequal development in the width of the laminae. Some of the laminae extend across the entire width of the crystal, but others do not, and generally they are not matched by similar laminae extending from the opposite

edge. In this way a greater thickness is developed on one side of a mica crystal than on the other. It is not uncommon for wedge-shaped sheets of quartz to be included between the laminae of such crystals. The "wedge" structure is often associated with the "A" and "fish-bone" structure.

In "A" mica there are two series of lines or striations crossing the sheets at angles of about 60 degrees with each other as at 2 and 3 in Fig. 1, whence the term "A." In some places these striations are caused by "wedge" structure developed in the mica crystals, with or without the presence of detached sword-blade-like strips of mica replacing the sheets that have "wedged" out. In other specimens the striations are caused by small folds, or crenulations, in the sheets of mica. The "A" striations have the same orientation in the mica sheets as the "ruling" lines; that is, their position corresponds to the rays of the percussion figure. "Ruling" is sometimes present in "A" mica. Where the striations are caused by small folds the mica sometimes splits across them and these sheets have a commercial value, though not as high as perfect plates. Where the striations are due to the "wedging" out of sheets, only plates from between the "A" lines can be used commercially and the value of large crystals is thus materially affected.

In the "herring-bone" structure, shown at 4, striations with or without "ruling" and apparently identical with the "A" lines of mica make angles of about 120 degrees with each other and join along a center line or spine. The "herring-bone" structure is probably caused by a twinning of two crystals of "A" mica, so that one set of striations in each fall together, and the other two sets are inclined toward each other and meet at the twinning line. Mica with the "fish-bone" structure has no commercial value as sheet mica, but is used as scrap for grinding.

In "tangle-sheet" mica (a name little used) the laminae split well over a portion of their extent but tear when split in other parts. This is due in some places, to the failure of certain laminae to form perfect sheets and the intergrowth of portions of one sheet with that lying next to it. Such imperfections sometimes extend through half an inch or more of the thickness of a crystal of mica. In this way an apparently sound crystal is rendered of little value or worthless for sheet purposes.

The color words descriptive of mica are self-explanatory, except the "white" and "black" mica of commerce. In speaking of the color of mica, the miners or dealers ordinarily consider the color of sheets a sixteenth of an inch or more in thickness. Such colors as "rum," "ruby," "green," etc., observed in the thicker sheets of mica, practically disappear when the mica is split into thin sheets for trade purposes. The mica is then called "white" mica to distinguish it from phlogopite or "amber" mica. By "black" mica is generally meant muscovite "specked" with magnetite, as described below, but in some cases dark-brown to black biotite is also called "black" mica. "Rum," "ruby," "green," and the lighter colored micas make the best grades of "white" mica for the glazing trade. Dark brown and brownish-green mica has to be split much thinner than "rum" mica to gain the desired transparency and is therefore generally classed as No. 2, even when flawless and clear.

Some muscovite shows color variations arranged in accordance with the crystal structure. These more commonly appear in zonal bands following the crystal outline. Thus, to one looking through the sheets there may appear a center of dark "rum" color with a fringe of light "rum" or yellow surrounding it and possessing a hexagonal or rhombic outline; or the center may be light colored and the border zone dark, as at 5, Fig. 1. In some sheets there are alterations of bands of varying color. Such color variations generally entirely disappear when the mica is split into sheets of the thickness required by the trade.

The pleochroism of mica is strong and may be well observed in small crystals with prism planes sufficiently smooth to transmit light. It will be found that crystals of such mica viewed edgewise are far more transparent than sheets of the same

thickness. The color is also quite different in these two views. Muscovite containing inclusions between the laminae of spots or particles of different colored minerals is called "specked" and sometimes also "black" mica. Magnetite is the most common inclusion between the laminae and occurs as black to brown dendritic tufts arranged in definite lines, or patterns, corresponding to the crystal structure of the mica or scattered irregularly through the sheets. These tufts of magnetite are very thin and rarely penetrate appreciable thicknesses of mica. The dark brownish color of many of these spots is due to the translucency of the thin films of magnetic iron. The arrangement of the streaks of spots in the mica is in some cases parallel to the direction of the rays of the percussion figure as at 6 Fig. 1, and in other cases it is apparently parallel to the rays of the pressure figure as at 7. Each spot owes its dendritic appearance to the arrangement of still smaller particles of magnetite in lines following in some cases at least, the rays of the percussion figure as 8, Fig. 1. From these lines of particles other particles branch off at more or less definite angles. By decomposition the magnetite is sometimes partly or entirely altered to hematite or limonite and the "specks" become red or yellowish brown. In this way striking patterns in colors are produced which gives rise to the name "hieroglyphic" mica and which were once thought to be the inscriptions of the aborigines.

In the zone of surface weathering, and principally within a few feet of the surface, mica crystals are sometimes "clay stained." This is due to the working in of clayey solutions between the laminae. The solutions penetrate large areas of some crystals and work in between many of the laminae, greatly damaging the value of the mica.

"Specked," or "clay-stained," mica has little if any value in the glazing trade, though either can be used in electrical manufacture. Their application even in the latter industry is less extensive than that of clear or "white" mica. Mica with "specks" of magnetic iron is not satisfactory for insulation where electric currents of high potentiality are used, because the "specks" tend to weaken the insulating qualities by acting as lines of less resistance.

Occasionally crystals, or sheets, of biotite are included in the muscovite crystals, or vice versa. In such a case the two micas generally occur in parallel intergrowths and have a common cleavage plane. Large crystals of muscovite sometimes inclose smaller ones with no definite orientation. The cleavage of the included crystal is generally inclined or at right angles to that of the host.

采 采

The Passing of Mining at Freiberg

The entire country surrounding the old town of Freiberg, in the Kingdom of Saxony, known the world over for its silver mines, is one net of subterranean galleries, from which enormous riches were brought to the surface. The silver mines have been worked for over 700 years and yielded, according to a report just made by the Royal Saxon government to the Diet, more than five million kilograms of silver, valued at nine hundred million marks, besides large quantities of lead, sulphur, arsenic, zinc, and other treasures. The low price of silver in the world's market has made mining at Freiberg unprofitable for quite some time, and the Saxon government has had a deficit for years amounting to millions, but kept the mines going only for the sake of the mine officials and miners. Since 1903, however, in accordance with the decision of the Diet, the mines are being gradually dismantled with the intention of stopping operations entirely. They appear in the budget for the last time, and next year work will be discontinued. The government report from which the facts here given are obtained concludes by saying: "Then Freiberg mining, once the pride and the source of wealth of Saxony, will belong to history." This will interest many Americans who studied at Freiberg.

The Miami, Okla., Mining Camp

Early Prospecting and Mining Methods—Handling Water Impregnated With Gas

By C. H. Plumb*

After 4 full years of production a review of the Miami lead and zinc camp shows interesting facts and figures. Shipping its first ore from the New State mine in September, 1907, the camp has produced to January 1, 1912, \$1,764,094 worth of ore and developed an ore deposit of peculiar dimensions and features.

At the outset prospect drilling was carried on in all directions, and this, together with the development of the mine, proved a deposit of ore with a length of 4,200 feet, a width of from 75 to 200 feet, a thickness of from 30 to 60 feet, and a general trend of N 25° W. Paralleling and west of this deposit are several ore deposits of comparatively small dimensions.

TABLE 1

Year	Zinc Pounds	Value	Lead Pounds	Value	Total Value	Rank Among Camps of District
1907	119,340	\$ 2,446	31,520	\$ 725	\$ 3,171	25
1908	13,959,628	160,506	2,708,560	74,194	234,684	12
1909	24,744,690	411,789	7,907,385	211,852	623,641	6
1910	20,311,390	332,250	6,775,025	176,489	508,739	6
1911	16,363,680	243,977	5,354,105	149,882	393,859	8
Totals	75,498,728	\$1,150,968	22,776,595	\$613,142	\$1,764,094	

The first mining operations were confined to the top 20 feet of ore, and from the Swastika to the north end of the Emma Gordon, shown in Fig. 1, this has been completely worked out. Later work consisted in mining below this bench, and stopes having been worked over practically all this area, the life of the camp seemed to be limited to not more than a year's more work. Of all the mines on the smaller deposits to the west, only the Queen City-Joplin can have made any money. As in all prospecting, the enthusiasm of the miners was greater than their judgment, and several mills were built that have not repaid the money invested and some of them have hardly turned a wheel.

Practically all the land was held under first lease from the Indians by the Miami Royalty Co., at 5 per cent. royalty, and subleased at excessive royalties to the different mining companies.

In spite of the royalties, which ranged from 20 to 40 per cent. and the grade of the ore, which averaged about 8 per cent. below base, the ore which ran from 15 to 30 per cent. blende made possible large profits from the mines on the main ore deposit. At the present time the following mills are operating on the upper deposit of ore: The King Jack, New State, Turkey Fat, Miami-Amalgamated, Old Chief, and Emma Gordon. The mills that are idle or worked intermittently are the Morning Star, Queen City-Joplin, Okmulgee, Call, Lolita, Consolidated, Chatham, Midas, Miami-Yankee, Donna, and Jennie May.

TABLE 2

Year	Average Price of Zinc	District Average for Zinc	Average Price for Lead	District Average for Lead	Ratio of Production of Zinc to Lead
1907	\$41.00	\$43.68	\$46.00	\$68.90	3.8
1908	23.00	34.40	54.80	55.03	5.2
1909	33.30	40.47	53.00	54.78	3.1
1910	32.70	40.18	52.10	52.58	3.0
1911	29.80	40.02	56.00	57.19	3.0

The production of the camp from the first turn-in in September, 1907, to the end of the year 1911, practically all from the upper deposit, is as shown in Table 1.

*Mining Engineer, Joplin, Mo.

The average price received for ore compared with the average received for the entire district, and the ratio of the camp's production of zinc and lead is shown in Table 2:

From the tables it will be seen that the camp jumped to sixth place in 2 years but that it reached its zenith in 1909. The price per ton for blende, in spite of its large iron and bitumen contents will average only about \$7 to \$10 under the average

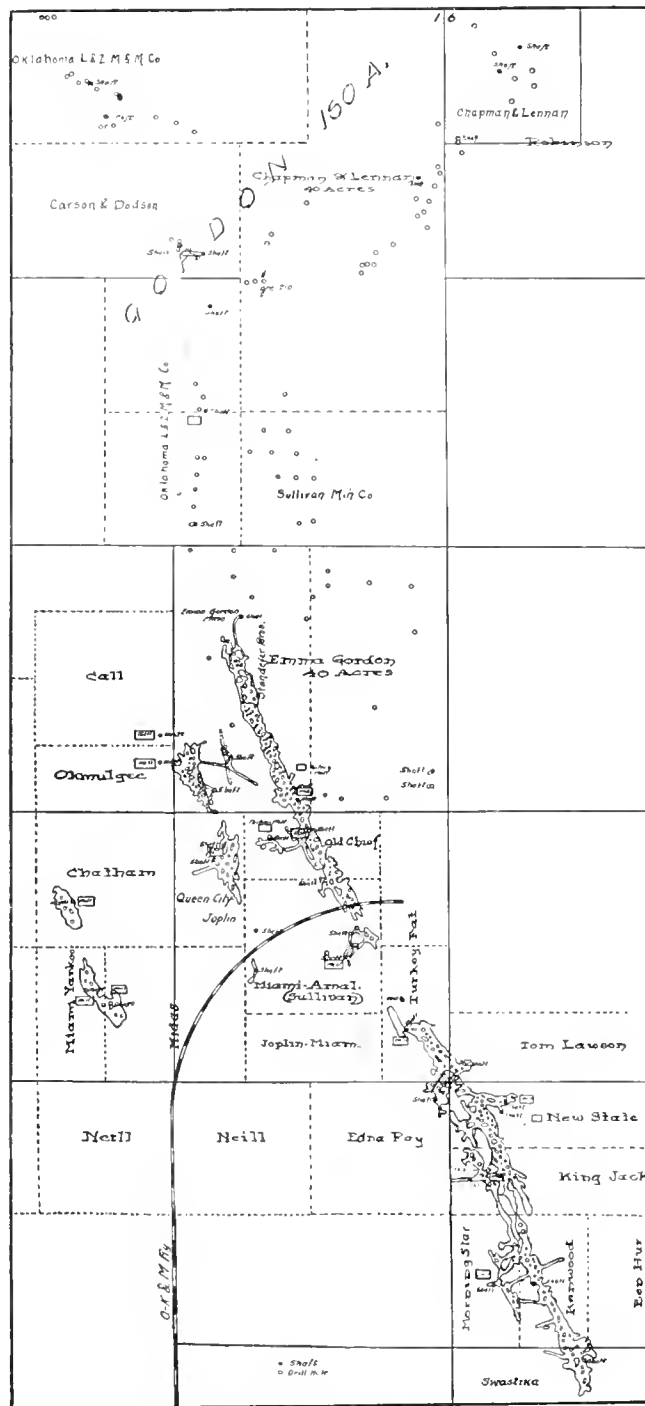

FIG. 1. MIAMI, OKLA., MINING DISTRICT

price for blende in the district, and galena about \$1 under the average price. The lead content is about 1 in 3, a very high ratio when compared to the ratio of 1 in 6.14 for the entire district.

At the outset the New State mine had great difficulty in keeping down the water, which was highly impregnated with hydrogen sulphide H_2S , and it was greatly feared that the flow

was artesian. It has been demonstrated, however, that the open nature of the ground is responsible for the large flow of water and that the deepest mine gets the water of the entire camp. In prospecting, a few deep holes were drilled on the north end of the Emma Gordon lease, and rich ore was encountered at about 210 feet, continuing down to about 250 feet. Two shafts were sunk to 230 feet depth and ore of great richness, and running over half lead, was demonstrated. The water which is highly impregnated with H_2S was kept down by continuous pumping so that the shafts could be sunk, but when the pump was stopped the water would rise in a few moments to the water level of the camp. For one year a company attempted to drain the ground from one shaft, and mine from another, and with two 7-inch steam pumps and one 9-inch, double-discharge Church-Barr centrifugal pump lowered the water level to 205 feet. Another centrifugal pump was then installed in the working shaft and mining started, no further attempt being made to lower the water level. This deep ore encouraged others to drill for it, and an ore body about 200 feet wide and about 40 feet thick has been developed for 4,600 feet, and another bearing northeast for a distance of 2,000 feet. The latter shows nearly 100 feet of rich ore to a depth of over 300 feet.

The Oklahoma Lead and Zinc M. and M. Co. is sinking five shafts; the Carson & Dodson Co. has two shafts in ore; Chapman & Lennan one shaft in ore and two more being sunk, and George W. Moore is sinking one shaft.

The deep ore in the north end of the camp started drilling for deep ore along the old deposit in the south end, and the King Jack has found ore from the 167-foot to 210-foot level. The Turkey Fat has a drill hole showing ore from about 200-foot to 250-foot level and a shaft 150 feet deep. The Miami-Amalgamated has ore from the 204-foot to 250-foot level, and a shaft 160 feet deep. The Old Chief has a shaft 202 feet deep in the lower deposit. The Consolidated also has a drill hole showing ore at about 185 feet depth. Nine drills are at work in the field at the present time and new leases are being prospected in the north end of the camp.

The ore has assayed: Zinc, 53 per cent.; lead, 4 per cent.; and iron, 2.10 per cent. These deep deposits that have been developed positively assure the life of the camp for at least 10 years.

The milling methods have not been changed radically to suit the ore, as it was expected would be done, but the common practice of the Joplin district is used. No ore roasting has been done except in an experimental way. Four tailing mills have been operated with good success, as all the tailing run high in ore.

During the past 4 years the camp has developed from nothing into a good one with ore in sight that exceeds any camp in the district.

來 來

Costs at Le Roi No. 2 Mines

The following is abstracted from a paper entitled "Mining and Concentrating Costs at Le Roi No. 2 Mines, Rosslund, B. C.," by Ernest Levy in the Journal of the Canadian Mining Institute.

The ore bodies at Le Roi No. 2 mines, Rosslund, B. C., are very erratic, both in position and in size, as well as disposition of values; additional difficulty is experienced owing to the visible ore seldom indicating its value, and this involves constant recourse to assaying. The ore bodies vary in width from a knife edge to 30 feet, requiring both the square set and "shrinkage" stoping methods of ore extraction. The latter method is followed as far as practicable on account of its smaller cost. By far the larger proportion of past production has been from between the 300- and 700-foot levels of the Josie mine.

The main shaft of the Josie mine inclines at 74 degrees, and extends to the 1,300-foot level. It is a three-compartment shaft 14 ft. 6 in. \times 5 ft. inside the timbers, and is equipped with a 150-

horsepower double conical-drum hoist. The shaft building is furnished with grizzlies, 4-inch and 1-inch spaces, on which hand sorting takes place. The ore is divided into first-class, second-class, and mill ore. The first-class fine ore is shipped to the smeltery, and the remaining material sorted into shipping, mill, and waste; the second-class fine ore is shipped to the mill, and the remainder distributed as in the case of the first class. The mill ore is trammed direct to the concentrator.

The No. 1 shaft is 800 feet deep, has three compartments, and is equipped with a hoisting engine similar to that at the Josie shaft and also has sorting floors in the head house.

To give an idea of the extent of the operations and what is accomplished by hand sorting, the figures covering the last financial year are as follows:

	Tons Extracted
First-class ore.....	42,770
Second-class ore.....	5,790
Mill ore.....	4,480
	53,040

which was sorted into:

	Tons
Shipping ore.....	29,776
Mill ore.....	17,535
Waste.....	5,711
	53,040

Stoping costs per ton were:

Ore production:	
Labor.....	\$.76
Explosives.....	.32
Illuminants.....	.03
Sundries.....	.04
Re-sorting labor.....	.21
General expense.....	.35
Power plant labor.....	.07
Supplies.....	.36
Mine general labor.....	.33
Supplies.....	.07
	\$2.54

The ore shipped averaged in assay: Gold, .8882 ounce; silver, .8086 ounce; copper, 1.6305 per cent.

During the financial year under notice there was accomplished 4,202 feet of drifting and cross-cutting, and 160 feet of raising and winzing, which cost \$17.72 per foot.

In addition to this, the main shaft was sunk 193 feet at a cost of \$75.56 per foot, and 11,508 feet of diamond drilling was done at a cost of \$1.73 per foot. The average depth of the drilled holes was 371 feet.

TABLE 1. COSTS OF MINING

Year Ending	Drifting and Cross-Cutting Feet	Raising and Winzing Feet	Total Footage	Cost Per Foot Total
1910	4,202	160	4,362	17.72
1909	3,220	338	3,558	14.35
1908	4,302	270	4,572	14.17
1907	2,538	255	2,793	14.58
1906	3,392	157	3,549	12.91

Costs of mining for 5 successive years are shown in Table 1.

The concentrating mill is capable of treating 60 tons of ore per diem. The machinery is electrically driven by motors aggregating 100 horsepower; and it comprises one 9" \times 16" and two 8" \times 12" Blake crushers, two 6-foot Chilean mills, and four shaking tables. During the last financial year the following grade of ore was treated, with the results as shown: Feed, 17,265 tons, assaying gold .122 ounce, silver .255 ounce, copper .554 per cent. Concentrate produced totalled 1,368 tons, assaying gold 1.297 ounces, silver .748 ounce, copper 1.144 per cent. Treatment cost per ton crushed, 99 cents. The company's mining and milling operations in Rosslund during the financial year October 1, 1909, to September 30, 1910, netted a profit of \$249,255.81.

來 來

Asbestos insulation is made of mineral pitch dissolved in a volatile solvent (benzine) and this solution made into a paste of finely crushed asbestos, which is compressed and dried at low temperature.

Fundamentals in Technical Education

Knowledge of the Underlying Principles Necessary to Avoid or to Detect Errors in Practice

By Regis Chauvenet*

In dismissing several fancied objections to technical training, we said that we would indicate what we conceive to be the true function of the technical school. We have not so much granted, as asserted, that no institutional or correspondence work can teach a young man how to meet the details of practice or the friction of management. If the preparation cannot even fit him to better handle technical problems than can the man who comes to his work with, say, equal natural abilities and similar age, but, so far as education is concerned, is scientifically illiterate; if he is no better prepared to acquire the details of actual practice so far as they are "technical," i. e., based upon scientific facts and principles; then, indeed, the opponents of technical education would have good ground to stand on.

We cannot give our definitions in a mere phrase. It is not possible to meet a very complex question with a very simple answer. If, in stating what appear to be the "fundamental" objects of technical training we do not cover all the ground at once, some further explanations by examples will serve to define our position.

We here invert a portion of the argument in favor of preparatory education, by asking a question of its opponents at the outset.

We shall then state a fact so familiar to start with, that it needs no statistical references to lack it, the fact, namely, that applications for admission to technical institutions (correspondence schools being here distinctly classed as coming under that category), come in without number from young men who are already holding positions of one kind or another "in the field," and whose sense of their own shortcomings, and of the handicap imposed by their deficient foundations, impels them to this step.

The "argument" then is so far one of facts. We put the "onus" on the opponent, asking him to explain why it is, if foundational work be useless, that so many who have tried the method of "superstructure first" should turn back to the "institution" for those lines which so many are prone in ignorance of their true import to term "theoretical."

What an abused term it is, by the way. What man ever started to do anything worth talking about 5 minutes without constructing some theory of his procedure and object? What man can explain the simplest supposition without forming a "theory?" This is all parenthetical, we grant, but it is amusing to hear some men use the word "theory" always with a sneer, and all through their lives proceed upon "theories" of their own, though they never call them so.

Take the idea of a man who is declaiming adversely about "theory" and sift it down, you will usually find that he means anything he doesn't understand. If he knows the four ground rules of arithmetic, they are "practical." But if he knows nothing whatever of decimals or proportion, those are "theoretical!"

Carrying his misuse of the word out logically, you will find that the building of a structure that won't stand would be considered "practical," and the computation and drawings of a proper structure would be "theoretical!"

The purpose of the preparatory school, then, is to present the "fundamental" scientific facts upon which rest the various applications classed under the broad term, "technical."

The scope of these articles does not cover the differentiation of the various branches, e. g., mechanical, metallurgical, mining, and the many subdivisions of "civil engineering." Some of our remarks and illustrations will fit any line, others probably would

be more specific in their application. All alike tend to the same view, viz., the utility of scientific foundations.

The technical school proposes:

1. To instruct in the elements of mathematics.
2. To present the facts of the physical sciences (chemistry, geology, and others) as nature gives them.
3. To combine this knowledge to the end of showing how man's art can use nature's forces.
4. To a certain extent, by the drafting room, the laboratory, the workshop, or field work, to lay good foundations for accurate practice.

As to the immediate results of such preparation, we take up the more negative first in order, so as to "clear the ground."

Any observer of field operations will, we believe, assent to our assertion that the most serious blunders of practice have arisen from lack of knowledge, not of matters of detail, but of natural laws.

Just as, in commercial and financial ventures, the world hears a great deal of the successes, and comparatively little of the failures (unless the latter are quite "spectacular") so in engineering and mining fields it is only practitioners who pay much attention to the causes of bad results.

Not many years ago a somewhat noted dam was constructed in the West, and the writer, not himself a "civil engineer," heard many adverse comments on its structure and safety from engineers of experience and repute. In fact it was a sort of "open secret" in the profession that this dam was a "job" and represented neither science in the plan, nor skill, nor honesty in the construction.

The dam was totally wrecked by a flood, and its brief history would have formed no part of this paper had it not been for the further fact that every newspaper account of the disaster asserted and reasserted that the work had been executed under most "eminent" engineers and had been approved by the "highest scientific authority," both of which statements were absolutely false; but, so far as we ever heard, no engineer ever went into print to "show up" the true conditions. This is no isolated case. Many engineers, probably, could recall instances in which the professional was directly opposed to the "popular" view, as presented in the press.

The tendency of the "press" is, of course, to address the ideas of a majority (or what it conceives to be a majority) of its readers. Incidents like the above go far to make people believe that the worst results of practice are as good as the best talent can guarantee! Not that this paragraphic misleading is confined to matters scientific—very far from it. Mr. Smith has been going "down hill" morally and financially for a long time, but when some default comes to light, hardly surprising his friends, does not "the press" invariably state that his character was never suspected, and that the act comes as a "shock," etc.?

Indirectly, a good deal is done by the press to encourage the idea that the "expert" is no better than, or not as good as, the "rule-of-thumb man."

Do we seem to have gone "far afield?" We are very close in point of fact to our topic. There are whole classes of blunders which originate in ignorance of fundamenta, and the technical school would have a great and useful field if it did no more than to protect its graduates from these dangers.

"Then," said a gentleman to the writer, when he was presenting some similar view, "you say that all the technical school can do is to keep a man from making a fool of himself!"

Not quite all! We may say that a man must eat to live, without excluding drinking and sleeping from his necessary functions. Let us, however, for a moment, suppose that the technical institution does keep all of its graduates from "making fools of themselves": what a glorious, almost unlimited, field of usefulness does it present, and how eagerly applicants should throng its doors!

We claim also that, if such a basis as above indicated be secured, the practical experience afterward garnered is obtained

* Mining Engineer, Denver, Colo. First article on this subject appeared in April number.

"in the light," and its value is doubled, while at the same time the difficulties involved in its acquisition are halved.

This, in a nutshell, constitutes the claim for technical education.

Regarding the not uncommon phenomenon of a young man working for some years and returning to the institution, or more commonly coming to the institution for the first time, after a considerable period of field work, it presents one decided disadvantage, rarely "discounted" by the would-be student, viz., he has lost the "school habit." Add that he has passed the age at which the memory is most retentive—though perhaps this does not greatly affect the case under the age of thirty.

Many have been the instances in which such a student has come to us, mortified, as was only natural, because "kids" of eighteen or nineteen were doing better than he could. He felt his greater maturity, he knew he was a "better man." Why couldn't he "make it?" The main reason as to the "kids" was that they were in the "swing" of work while he was being broken in again. Here is a hint for instructors new to such cases. A main cause of the trouble lies in defective method of study, though, for that matter, the same may be said of many students who have never broken off their courses.

"Show me how you study this lesson," we would say, and, after he had read a paragraph or two, ask: "What does that mean?" Rather simple, is it not? Here I am addressing any student, institutional or correspondence school. As you study, ask yourself that question.

Very often the student couldn't answer, i. e., couldn't say what it meant. This is one result of losing the study or school habit. Careful self-training is necessary to break oneself of the fatal habit of reading while thinking you are studying. You are mistaking memorization for acquisition, another error of youth which we drop hastily, as, knowing our own hobbies, we fear it might lead us astray. Ponder the text then—the sermon is spared you.

Other results of the loss of the "school habit" are lack of attention to the lecturer's words, and finally lack of comprehension of the forms of language employed.

This article is intended for reading by prospective students, among others, and we believe many of them could take this simple idea deep into their minds and find that application of it will enable them to save many hours. Be sure your mind has *taken firm hold* of what you have just read, then, my dear young man, you are really "studying"—otherwise not.

Commonplace? Yes, of course it is—very, very commonplace. It is also "fundamental." Take the wrong road at the start, and it may be a weary way back to regain the right direction.

We would discourage no one from trying to rectify what he feels to be his foundational shortcomings, the trial does him credit. His instructors should give him special help, since his deficiencies are due rather to adverse circumstances than to any fault of his own.

Having spoken of the disadvantages of taking a course after long desuetude from school work, we may speak of one advantage. With maturer years and a distinct idea of what he wants and means to get, the student under these conditions is at least in earnest, and does his best to get the most he can out of his course.

Nevertheless, these efforts often remind us of an old burlesque on the United States Survey of former times, by the almost forgotten humorist "Phoenix":

"Owing to the difficulties in measuring the base line, one of which was a puddle of very dirty water, and another the violent objections of a belligerent native whose premises were invaded, it was decided to triangulate first, and arrive at the length of the base line by subsequent calculations!"

As to the time to be given to a technical course, the question is too general, that is, it leads us into consideration of different courses, with different degrees, and so necessarily involves the

requirements of various professions, that (as we have already signified that we shall not "differentiate" in this respect) we are compelled to abstain from discussion of the point. Four years is not too long for any line. Columbia and Sheffield (Yale) have already extended the time for scientific courses.

Another point in this connection is the question: "In asking how long to make the course, where do you start?"

Many pages of expostulations have been printed harping on the fact familiar to so many instructors in colleges and technical schools, but more especially the latter, that "accredited" graduates of academies and high schools do not do justice to their "credits." This is only one phase of a fact which we dwell upon somewhat later, viz., the "break" in passing from the methods of the average public school into the professional atmosphere.

As to the relative time which should be devoted to lectures and to "practice," custom and convenience have alike dictated that the division of the day into A. M. and P. M. settles the question. This is not far, in most courses, from a reasonable division.

The "practice" of the school is only foundational, of course, but it is hard to imagine how some of it can ever be found in "real life," i. e., in its beginnings. This applies, with especial force, to chemical analysis, but it is true also of mechanical drafting, except of a kind very "mechanical" indeed.

No one expects professional work of a newly graduated student, of any high degree of accuracy, but the "breaking in" is far better accomplished in the school than afterward. These deficiencies felt by the untrained practitioner are the ones that bring many students to the "institutions."

From Principle to Application.—Every instructor knows that it is easier to inculcate principles than to get the student to apply them, in fact when problems involving even very simple applications are first presented, it is unusual to find more than a small fraction—about 10 or 15 per cent. of the class for an average—who will see how to cut the coat from the cloth. The best instructors will try to show simple applications from the start, not that they can bring in very practical problems, but to familiarize the student with the idea that he has had a tool placed in his hands which he can really use.

This should be done in the high-school grade, though it rarely is. Take for example, simple equations. The problem usually found in the school texts are seldom of any practical bearing. They are "more curious than useful." One of the reasons is that at this stage (i. e., in work earlier than that of the technical school), the data themselves of technical problems would hardly be apprehended by the pupils. For this reason we shall drop the strictly preparatory grades, and consider only the initial steps of the technical course proper.

In reviewing a class in plane geometry (just admitted to the technical institution, and nominally "credited" with that subject from their high school), we gave out the question: "How would you lay out the face of a clock, so as to most quickly get the 12 equal spaces for the 12 hours?" Every boy in the class knew that the side of a regular inscribed hexagon was equal to the radius. Not one of them thought of it in connection with this little problem.

Stupid? No. Badly taught? Possibly. At all events they had never been instructed to regard a fact given, so to speak, "in the abstract" as of any possible utility or application. Instructors in making allowance for the difficulty of passing from the abstract principle to the concrete application, should also help the pupil by these illustrations as often as possible. These same boys, after a few weeks were able to solve many problems by linear graphics, and to easily handle geometrical questions (applications) derived from first principles, though not themselves found in the text.

Similarly in elementary algebra, while any member of a class can quickly solve a given equation, a much smaller number will be able to derive one from assigned data ("statement") Practice in such work is very "fundamental."

How often have we seen a mountain made out of a mole hill for lack of seeing how to apply elementary algebra, and that, too, by persons who would treat the solution of the equations, once stated, as mere child's play.

Elementary chemistry affords many cases quite similar. It is a pity that applications which require some reasoning on the numerical relations of chemical reactions (stoichiometry) are neglected in most courses. "How much sulphuric acid will dissolve a pound of iron?" would not seem to be a very profound chemical problem, yet while we do not remember ever to have come across the necessity of answering that particular question in practice, we have seen many a man fail to solve questions absolutely similar in principle. Not, if you please, for lack of chemical education, such as it was, but because simple methods of applying facts had never been instilled. Facts of the science they had. Scientific methods they had not. Details of many chemical phenomena were familiar to them. Fundamental knowledge was wanting.

The writer was applied to, not long ago, on behalf of persons interested in the question of the contamination of air by the combustion of ordinary city gas in confined spaces. The main question raised was the volume of carbon dioxide CO_2 evolved in burning a given number of cubic feet of the gas.

The composition of the gas was known and formed part of the "data" under consideration. The discussion on the part of the committee appointed to settle the case was vague, and quite "unchemical." No one seemed to know whether the assertion made as to the volume of carbonic acid evolved was correct or not, and no one was able to use the analysis in settlement of the point. Yet there was really no "problem" involved! The equation of combustion gave the answer!

To illustrate this case we here simplify the actual data of analysis, as it does not change the elements of the problem so to do. It was known then, that the gas contained 10 per cent. of CO gas and 40 per cent. of CH_4 gas. (Carbon monoxide and methane.) The equations showing the combustion of the gas are:

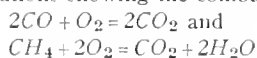

It did not appear that these equations had even been written. Strange but true, every member of the committee had had some chemical education, and in fact had been selected for that reason. Yet not one of them knew that without even "putting pencil to paper" in the way of calculation, the "statement" of their problem also gave the answer.

We have omitted a trivial percentage of the "olefiant" gases from the statement. The equations show that the volume of "carbon dioxide" evolved (equal temperatures being understood) is exactly the same as that of the two gases considered. The assertion they were considering was that the gas in burning evolved twice its own volume of carbon dioxide. This assertion had been printed and sent broadcast. How very little "fundamental" chemistry would have set this "committee" right.

We again illustrate in this example, the value of elementary instruction. But we are using that word "elementary" in a sense perhaps different from that for which it usually passes. The members of the committee all supposed that they knew something of chemistry, and in a sense, they did. But its "elements" had never made any real impression on them, perhaps it would be fairer to say had never been rubbed into them. They were ignorant of the true significance of nomenclature, or rather symbolism, and in fact, when the solution was shown them, though they accepted it unreservedly, they all agreed that "they would never have thought of that!"

Scientific method again—far ahead of "scientific facts."

For the benefit of any chemical student who may read this article, let us step aside for a moment to discuss the above. First principles are *not* "first principles" in the mind of the learner, unless they have been mastered in such a way as to become part of the mind of the one acquiring them. The true "fundamenta" properly fixed, can no more be "forgotten" than we can "forget"

the letters of the alphabet. We shall use the above equation to show what we mean. Take the single one: $2CO + O_2 = 2CO_2$.

If the chemical student has once learned to read gas volumes at sight, they stand out in their volume relations as familiarly as words in print.

He may forget the properties of these gases, he may forget their atomic or molecular weights, but if he can forget what the very A B C of chemical symbolism means—why then, he never knew!

In illustrating, we have not yet answered literally our own question as to what constitute the more necessary "fundamenta" of applied science. They are found by title in every schedule of technical institutions. What really concerns us, is not their titles but the methods of their acquisition. We say that really "first" principles should be so laid down that "difficulty" is banished.

In starting into a new science, three things, all necessary, often lead the student astray.

Rules, Definitions, and Formulas.—We remember a student coming from "field work" to a technical school, and eager in his desire for knowledge, who after a lecture by a certain professor, remained behind after the class was dismissed, and, with a smile that showed he thought he had his instructor "cornered," said: "Professor, you gave three definitions today for the same thing."

He produced his notes and read them. "No," said the professor, "I gave you three facts about that thing, but I haven't given any general definitions, and, in fact, the class isn't ready yet for that. When it needs one, it will have to construct its own definition."

One of the best German texts on chemistry, started with the statement that it would be useless to attempt a definition of chemistry without some prior knowledge of its phenomena, and then proceeded without more ado, to give the results of certain chemical experiments. This has found many imitators, in other lands and languages.

Most instructors in advanced lines know that rules are a stumbling block to a carelessly instructed student, and definitions may become almost as bad. We speak of abuses, not of uses. In elementary mathematics, and even more in arithmetic, the pupil is always falling back on the rule, forgetting the principle back of the rule. No teacher in the "grades" but that tells how often a child tries the wrong rule on a problem. Many beginners, to say nothing of a good many who are anything but beginners, are quite at sea on a given question unless they are told what "rule" it comes under.

Too much of the idea of finality attaches to both rule and definition. A scientific definition is a necessary thing, but badly used it is but too apt to make the student—especially the young student—think that he knows all there is to know about the thing defined. He seizes on the ready-made definition as something tangible, he allows his mind to rest in it. Satisfied (as he should not be) with a formal verbal statement, he does not sufficiently consider all its bearings, but lets the formulistic epitome "do the work for him," as he imagines.

As few "principles" are ever brought home without a great deal of repetition, we shall here repeat again: This is only another case of method before details.

The value of a definition constructed by the student himself is many times that of one handed to him as a hard and fast formula, "ready made." Why? Because his own definition, though it may lack some elements of completeness, or of scientific accuracy, must necessarily be the resultant of some constructive thought on his part. The childish habit of accepting a definition without any thought of the connection, should be broken early, or it may hang on to an age at which it should make the student ashamed of himself. We are reminded of the extreme case of the school pupil who heard the equator defined as "an imaginary line," and not perfectly hearing or not understanding, repeated it when called on, as "a menagerie lion."

The same thing is true of many rules and formulas. It is far from our intention to minimize the utility or the necessity

of either, but the practitioner who cannot see the fitness of the definition and use it as an epitome of living facts (living to him, observe), or who cannot, if called on, shape a "rule" or derive a formula, is in sorry case. If he cannot originate in small things, how shall he rule over many things?

It may be doubted whether there live engineers of any experience who have never met with misapplications of either rules or formulas. Such blunders are not always the results of mere stupidity. If they are not, it will be found that the cause of them lies deep and is to be traced ultimately to the lack of true foundational grounding.

"I say, Smith," said one American tourist to another, as they sat in a Parisian restaurant, "I want a glass of water. How do you ask for it?"

"You just say 'deelo,'" replied Smith.

"Does deelo mean water?" asked No. 1.

"I don't know what deelo means," said Smith, "and I don't care. But I notice that if you say deelo, you'll get water."

That was Smith's "formula." He got the water, so "he knew he was right." We can parallel his case without going into ancient history, for it was but a few months ago that we met a foreman who had frequent occasion to use a formula involving the expression "cos. x ." He knew how to "take it out" and substitute it. But all our ideas concerning his trigonometric knowledge were suddenly upset when he asked us:

"I've often wondered what a cosine is. Can you tell me?"

In the telling, we struck so happy an instance of the "object lesson" that we are tempted to give the little experience in detail.

First, we tried to explain the cosine from the right-angled triangle, "ratio of adjacent side to hypotenuse."

This was a dead failure. Served us right, for we should have first ascertained whether he had any clear conception of a ratio. He hadn't.

Next we drew the usual figure and showed him the cosine graphically, as a portion of the radius intercepted by the vertical.

Another failure, though a glimmer of "light ahead" was apparent.

"Happy thought!" A barrel head (circle), a straight stick (radius), and a bit of string, the latter tied to the end of the "radius vector." As it moved he saw the diminishing cosine, and made a remark which showed that he was by no means devoid of the power of observation:

"It always dazed me to find that the bigger the angle the smaller the cosine!"

We heard later that he was taking a "course" in a correspondence school. Success to him. We have forgotten his name, but we shall always remember his cosine.

Now how far from the narrow, beaten track of that one formula could that man have traveled? How "dazed" indeed he would have been had he had to solve a problem involving the most childishly simple use of a cosine, except his one little problem.

Yet we have heard the inculcation of formulas, as such, i. e., without any knowledge of their derivation, seriously advocated. Except by inference, we have no arguments to oppose to such advocates. "Reason is too good a thing to waste on them."

Here we'll insert the little problem of Mr. Archimedes, of Syracuse. It is not necessary to tell the bath-tub story, nor how he ran naked into the street crying: "Eureka, eureka!" We never half believed that last detail, it sounds too much like the reportorial flourish of a Syracuse newspaper.

The problem is usually applied today in finding the relative weights of gold and quartz in a mingled mass of the two. It could be applied to other questions involving artificial, composite structures susceptible of being weighed. If the reader cares to exercise his wits and the formula for a few minutes we will give a case and its answer, to be verified as practice in the use of a formula. This, aside from our illustration.

Specific gravity of gold is 19.3, of quartz 2.66. Weight of the specimen, i. e., the mixed mass of gold and quartz is 10 (10

in any unit, answer will of course be in the same unit). Specific gravity of the mass by trial is 6.

Find weights of the gold and of the quartz.

Answer. Gold weighs 6.45, quartz weighs 3.55.

However, that is a digression. Let us take the case as a general problem.

Call specific gravity of the first substance a . Of the second b .

Call weight of the mass c and its specific gravity d .

Call the unknown weights of first and second substances x and y .

We bring in this problem and our experience with an attempt at formulistic solution (blind) because of the simplicity of the principle involved and consequent ease of the derivation of the formula.

Obviously, the sum of the two weights must equal the weight of the mass. Also, the volumes of the two must equal the volume of the mass.

Since we know that the volume of any substance equals its weight divided by its specific gravity, these two self-evident propositions are expressed thus:

$$x + y = c \text{ and } \frac{x}{a} + \frac{y}{b} = \frac{c}{d}$$

The first of these reads, "weights of the two substances are equal to the weight of the mass."

The second one reads, "volumes of the two substances equals volume of the mass."

$$\text{Whence, } x = \frac{a c (d - b)}{d (a - b)} \text{ and } y = \frac{b c (a - d)}{d (a - b)}$$

All of which is a long introduction to a short story. The "subject" was a graduate who frankly confessed that he had never grasped his "fundamentals."

"Those formulas," he said to the writer, "are no account. They give results which are wrong on their very face."

They certainly did. For by error of printer or copyist he had them wrong. "Only a letter or two!"

But he had become a "formulistic slave" and never tried—more probably he didn't know how to try—to restate the conditions and derive his solution.

This is a mere "fancy" problem. But it serves just as well as another to "point the moral and adorn the tale."

Some further illustrations and the consideration of the "correspondence" system are reserved for the final article.

來 來

Cerium Tin Alloys

The cerium tin alloys were investigated by the method of thermal analysis, combined with microscopic examination, and the equilibrium diagram of the system is given. The metals are miscible in all proportions in the molten state, and form the compounds Ce_2Sn , Ce_2Sn_3 , and $CeSn_2$, which are highly exothermic and melt at 1400° C., 1165° C., and 1135° C., respectively. These alloys are attacked by water, with the evolution of gas, and those containing up to 50 per cent. of tin are rapily oxidized on exposure to air; when they contain less than 80 per cent. of tin they are pyrophoric, and emit sparks when scratched. The maximum pyrophoric effect is observed with the alloy containing 30 per cent. of tin, which corresponds to the compound Ce_2Sn ; and this also exhibits the maximum hardness. The cerium-lead alloys bear a general resemblance to these cerium-tin alloys.—R. Vogel. (Zeits. Anorg. Chem., Vol. LXXXII, 319.)

來 來

Russia produces about 90 per cent. of the world's output of platinum, it being found chiefly in the Ural Mountains. According to the U. S. Consular Report, in 1910 the output reached 12,045 pounds, compared with 11,250 pounds for the preceding year. The total output of silver in 1910 reached 284,126 ounces. The total production of copper in 1910 rose to 49,801,416 pounds, against 40,641,804 pounds for the previous year.

Mines and Minerals

Vol. XXXII—No. 11.

SCRANTON, PA.—JUNE, 1912—DENVER, COLO.

Price, 25 Cents

PUBLISHED MONTHLY AT SCRANTON, PA.

ESTABLISHED 1881

INTERNATIONAL TEXTBOOK CO., PUBLISHERS

T. J. FOSTER, President S. P. ALLEN, Secretary E. H. LAWALL, Treasurer
RUFUS J. FOSTER, Vice-President and Manager
EUGENE B. WILSON, Editor ARTHUR J. HOSKIN, Associate Editor

WESTERN EDITORIAL OFFICE: 1221-1222 First Nat'l Bank Bldg., Denver, Colo.

CHICAGO OFFICE: 1006 Michigan Ave.

Entered at the Post Office at Scranton, Pa., as second-class matter
Address all business communications to MINES AND MINERALS, Scranton, Pa.
CABLE ADDRESS, "RETSOF, SCRANTON"

LONDON OFFICE: INTERNATIONAL BUILDINGS, KINGSWAY, LONDON, W. C.
SOUTH AFRICAN OFFICE: MANSION HOUSE CHAMBERS, ALDERLEY
STREET, CAPE TOWN.

NEW ZEALAND OFFICE: 63 DINON STREET, WELLINGTON.

AUSTRALIAN OFFICE: 83 PITT STREET, SYDNEY.

SUBSCRIPTION RATES

Single Copies.....25 cents
Yearly Subscription, including postage:
To United States, Mexico, Cuba, Porto Rico, Hawaii, and Philippines.....\$2.00
To Canada.....2.50
To all other countries.....3.00
The date after your name on the wrapper is that of the month to which your subscription has been paid. If you do not want to continue your subscription after that time, kindly notify us.
Notice to discontinue or change of address should be sent to the Scranton office.
When notifying us of a change of address always give your FORMER as well as your present address.

TABLE OF CONTENTS

EDITORIAL—	
Hookworm—Chino Copper Mine—Dome Mill—The Hollinger Report— The Selection of State Mine Inspectors—Mining a Business Invest- ment—Dome Mine, Porcupine, Ontario.....	633
TO DECREASE ANTHRACITE MINE ACCIDENTS.....	636
OUR COVER PICTURE.....	636
ANODE RESIDUES—CORRECTION.....	636
COAL MINING AND PREPARATION	
THE BUCK MOUNTAIN COAL BREAKER.....	637
BOILER COAL ELEVATOR, NAVAJO MINE.....	640
HYDRAULIC PILING IN EUROPEAN MINES, by L. Bucherer.....	641
ANTHRACITE LAWS AND THE COAL INDUSTRY, by Glenn W. Traer.....	644
1911 BITUMINOUS MINING LAWS OF PENNSYLVANIA.....	646
A CHANGE HOUSE FOR COAL MINERS, by A. A. Steel.....	647
ROILER ASHES FOR MINE ROADS.....	648
MINE CAR DOOR LATCH.....	648
PROGRESS IN KENTUCKY GEOLOGY.....	649
PRACTICAL COAL HAULAGE, by A. E. Thompson.....	650
ATMOSPHERES THAT EXTINGUISH FLAMES.....	650
AIR COMPRESSOR EXPLOSION, by W. L. Affolder.....	651
CATALOGS RECEIVED.....	652
OBITUARY—	
Edgar J. Meyer—H. Forbes Julian—Benjamin Guggenheim—Ernest A. Sjostedt—Major Jacob Roberts.....	652
COMBATING MINERS' DISEASES.....	653
ROCKVALE NEW AIR SLOPE.....	653
LOOKOUT MOUNTAIN COAL MEASURES, by A. W. Evans.....	654
PERSONALS.....	656
ELECTRICITY IN THE D. L. & W. MINES.....	657
CORRESPONDENCE—	
Positions of Stoppings to Withstand Explosions—Difficulties in Sam- pling Free Milling Gold Ore—Humidifying Mine Air—Coal Wash- ing.....	659
REVIVING SUFFOCATED MINERS, by Henry Hale.....	661
ANSWERS TO EXAMINATION QUESTIONS—	
First-Class Certificates, New South Wales, Australia, 1911.....	662
SWITCH AT NAVAJO MINE, NEW MEX.....	664
ORE MINING AND METALLURGY	
LAKE OF THE WOODS MINING DISTRICT, by William J. Richards.....	665
LABORATORY TEST ON CYANIDE ORE, by Linderfelt and Stewart.....	666
THE CHINO COPPER CO.....	668
BRASS AND BRONZE ALLOYS.....	670
PARTING TRAY.....	670
ZINC MINES IN SOUTHERN NEVADA, by Douglas White.....	671
BLOCK CAVING AND SUBSTOPPING, by Fred. C. Roberts.....	674
MINING SOCIETY AND EDUCATIONAL NOTES.....	675
A DURABLE SHAKING SCREEN, by Roy Reddie.....	676
BOOK REVIEW.....	677
REDUCING CALIFORNIA DREDGING COSTS, by Al. H. Martin.....	678
BONUS SYSTEM ON LOS ANGELES AQUEDUCT.....	679
THE HIGH-GRADE MINING DISTRICT.....	681
CONSIDERATIONS BEFORE OPENING MINES, by Arthur L. Hoskin.....	682
IODIDE METHOD OF COPPER ASSAY, by Thorington Chase.....	684
EFFICIENCY OF FINE SCREENING DEVICES.....	685
FUNDAMENTALS OF TECHNICAL EDUCATION, by Regis Chauvenet.....	688
TRADE NOTICES.....	692
A CONVENIENT BURETTE STAND.....	692
SCUJBS—	
Size of Engine to Drive Fan, 660—Practicability of Room-and-Pillar Mining, 661—Air Compressor Lubrication, 664—Boss Amalgama- tion Process, 667—The New Ore, "Calafatita," 681—Utilizing Water in Mines, 683—Oil Developments in Chile, 684—Auric Hydroxide, 687—Gold Mining in Siberian District.....	687

WORD has been received from the Bureau of Mines that ankylostomiasis is hook-worm. This latter speaks easier and writes more fluently; however, it is a surprise to learn that it is a miner's disease in a number of different localities in the United States.

來 來

PROPOS of the article on the Chino Copper mine in this issue, comes the news that the third unit of the mill has been put in operation. The first section started in November last, and the starting of the third section marks the completion of the original designed plant in less than 2 years. It is proposed to increase the plant to five units, giving the mill a capacity of 5,000 tons a day.

來 來

ADVICES to the *Mining and Scientific Press* state that the tailing from the cyanide plant of the Dome mill contains 7 cents in gold; and the *Engineering and Mining Journal* gives the Dome mill credit for 97 per cent. recovery, which is excellent mill work. Taking both statements together, it is evident that the 7 cents gold in the tailing is 3 per cent. of the gold in the ore, and 100 per cent. of the gold in the ore is therefore \$2.33 $\frac{1}{2}$. Other advices state that in the next few months Dome and Hollinger should reduce the cost of operation to \$4 per ton. If our contemporaries are both correct, where does the profit come in?

來 來

The Hollinger Report

THE editorial on "Overproduction of Mine Shares," which appeared in our March issue, seems to have shaken the very mining foundations of Toronto, and yet, after all, if heeded will be of great value to citizens of Canada. Our esteemed contemporary, the *Canadian Mining Journal*, rather thinks we were wrongly informed, while the editor of the *Cobalt Nugget* says No! The words used are in the preliminary report. The two sentences quoted, which seem to have worried the *Toronto Globe* and the *Canadian Mining Journal*, have been amended, but their analysis is scarcely improved. The first reads: "It is probable that this vein will continue to carry values to depths of several hundred feet below our present workings, and it is reasonably certain that for the purpose of this report an allowance of 300 feet of depth for the entire vein will not lead to any disappointments."

Our contention is that in a report of this kind nothing should be estimated unless it is in sight and its assay

value is known, and particularly in the case of a mine whose shares are selling in the open market at more than twice their par value.

Continuing, the report reads: "Judged from past experiences, and results obtained in other pre-Cambrian fields in other parts of the world, we may look for a continuance of values to depths of over 1,000 or 1,500 feet, and the consensus of opinion among engineers who have visited our property is that the vein and values will persist to some such depths."

This sentence might mean something or again the reverse. If the pre-Cambrian fields such as the writer has in mind are a criterion, the outlook for Porcupine is poor: for that reason the fields should have been specified. However, to try to bolster up a gold property in one field on the strength of some other property in another field savors of the promoter that has shares to sell. The names of the engineers who made the statements should have been given, otherwise what they said should have been left out of the report.

After these retroactive statements, the following appears in the report as a separate paragraph: "Academically, this is a reasonable hypothesis; commercially, it is speculative and remains to be proven." The *Canadian Mining Journal* remarking on this says: "Nothing could be more cautious and rigidly professional than the language of this last paragraph." Caution is foresight, not hindsight, and any rider attached to a statement in a mine report is an excuse for something; therefore, if the two sentences criticized had been omitted from the report the language would have been more "rigidly professional." Had the report stated "I have great belief in the future of the property, which will not be run with one eye on the hoist, and the other on the stock ticker," then the report would have been worth while.

MINES AND MINERALS is not opposed to Porcupine or the Hollinger interests. It is now, as it ever has been, in favor of mines standing on their own merits, and against using any particular mine for booming the stock of another.

変 来

The Selection of State Mine Inspectors

ONE of the worst features of the mine laws of some states is the provision for the election of State Mine Inspectors by popular vote.

Even when, as in the present Anthracite Mine Law of Pennsylvania, the nominees for the office must be men who have passed a satisfactory examination, the plan is a vicious one.

It lowers the standard of the office and tends to make the incumbent, even if technically competent, truckle to the opinions of politicians, saloon keepers, and others whose influence should have absolutely no weight in his selection. It deters many men of superior qualifications from seeking the office, because as political candidates they must contribute heavily to their party's campaign

fund, and then run the risk of being defeated, even if their qualifications are superior to those of their opponents. Besides, the position is one whose duties require all the time of the incumbent of the office, and if faithful to his duty he has no time to devote to campaigning from the time he registers as a candidate at the primaries, or earlier, till after the regular election. If he enforces the law and holds certain mine officials responsible for violations, he incurs their enmity and loses their votes and the votes of all they can in any way influence. If he compels working miners to observe the law, and prosecutes flagrant violations, he is accused of persecuting the workingmen, and that charge is used with telling effect against him at the polls. Every intelligent miner knows that the mine laws are frequently violated by mine workers, who not only recklessly endanger their own lives, but those of their fellow workers as well. Every intelligent miner also knows that there are violations of the law by some mine foremen and fire bosses, and that the overlooking of such violations encourages others. If a mine inspector does his full duty regardless of whom the penalty hits, he has very little chance for reelection.

Unfortunately there are many mine workers unable to understand English, and in no sense well informed technically, who can be easily influenced against the candidacy of an able and conscientious inspector, and be led to work and vote against the man whose services would be most valuable to them. Therefore, if he does his full duty, his chances of filling the office for more than one term are comparatively small. If, on the other hand, he truckles to both sides, and simply makes a show of doing his work, he is a good fellow, and can be reasonably sure of reelection, if he supports his party machine, and makes himself solid with the saloon keepers, bartenders, and others who exert an influence in general elections, even if they are absolutely unqualified to pass on the merits of a candidate for State Mine Inspector.

As far as the farmer vote is concerned, he will get that portion of it that belongs to the party on whose ticket he is a candidate. They won't assume to vote for a Mine Inspector on merit. Knowing practically nothing of the qualifications required, farmers will vote for their party's nominee. It is claimed that the United Mine Workers favor the election of mine inspectors. This may be true as far as a majority of that organization is concerned, but we do not believe a majority of the more intelligent skilled miners will favor such a policy when they seriously consider its evils and the chances it offers for the selection of inspectors who are not competent to, or who for selfish reasons will not, faithfully perform their duties.

The system is a bad one, even when men aspiring for the nominations have passed examinations showing their technical ability. It is infinitely worse when no examination or a less rigid examination is required.

In the foregoing we have no intention of reflecting on the ability and faithfulness of the present body of State

Mine Inspectors for the anthracite regions of Pennsylvania. As a whole they are able and conscientious men, but there have been some for whom this cannot be said.

It is safe to say that of the present body, there isn't one, regardless of his party affiliations, who does not believe the former system of the Governor appointing inspectors from among those who had proved their competency, is the best way to secure efficiency in every respect.

There isn't one of the present Anthracite Mine Inspectors who would hesitate very long in resigning to accept a mine managership at the same salary he is receiving from the State, because such a position would be good for life or good behavior, and would not be subject to the chances of an election every four years with its attending annoyances and evils.

When the former and better plan of selecting inspectors was in force, there were no politics considered. Republican governors appointed Democrats, and Governor Pattison, who was the only Democratic Governor of Pennsylvania in many years, appointed Republicans. The question of partisan politics was not considered. Character and efficiency were the requirements. Under the old law every inspector who did his duty, and who kept abreast with the increase of knowledge pertaining to coal mining knew he would be reappointed and kept in office as long as he was physically able to perform its duties. Naturally, every year of service added to his efficiency. If a corporation, recognizing his ability, desired to employ him, it had to offer him a considerable increase in salary and other substantial inducements to get him. The State should have the best. But it cannot keep the best, if the conditions are such as to force men, for their own good, to leave the service of the State for the service of private corporations.

A commission is now at work revising and codifying the Anthracite Mine Law of Pennsylvania, and the time is ripe to change the present vicious system. A change can be made if the intelligent mine workers and mine officials get busy at once. Both classes are vitally interested in a law providing for the selection of the most competent men of highest character as inspectors. The politicians are vitally interested in keeping the office an elective one. The politician's interest in the mine worker usually ends when he gets his vote. He should have absolutely no say in the selection of State Mine Inspectors.

☞ ☞

Mining a Business Investment

IN A RECENT humorous sketch, George Fitch took for his topic, "April," and after dealing at some length in absurdities regarding this spring month, winds up as follows:

"April is a beautiful month south of Mason and Dixon's celebrated line. North of this line, however, it is like a stock company gold mine—it consists mostly of prospects."

This is but one of the numerous slurs that have been

pervading popular journalism the past year. Writers have been going to much pains to impress upon the general reading public that mining is a thing to shun. One writer in the *Saturday Evening Post* went so far as to emphatically state that not one cent should be put into anything that pertains to mining. There is some comfort to us in the fact that this writer has never been heard of before in mining circles, and he probably knows nothing of his subject except as he has gleaned data in the brokerage markets of the big cities, where the notorious operations of mining sharks hold sway.

The detractors of the mining industry appear to fail completely in appreciating the fact that real mining is just as legitimate as any other industry—mercantile, manufacturing, or agricultural. The perpetrations of crooks have invaded every line of business. Mining is not responsible for the gullibility that makes it possible for sharks to thrive, for this is a trait in the human make-up. It is not *mining* that fleeces people; it is *make-believe mining*. Statistics can be quoted to prove that real mining results in a smaller number of failures than any other line of business. If the general public can be brought to realize a distinction between genuine and fake promotions; if people will put the same common sense into an investment in mining property as they would if putting their funds into any other kind of property; and if, finally, investors would insist upon the activities of their companies being controlled by experienced mining men rather than by the promoters' relatives who need "jobs," we feel confident that there would be exceedingly few failures.

When people contemplate investments in lines of business with which they may not be personally familiar, it is the custom to employ the advice of persons who are experienced in such lines. Experts are engaged to investigate the probabilities of success in the proposed new enterprises. Inventories are taken, if the investments be in the nature of purchasing operating establishments. And yet thousands will put their hard-earned savings into the pockets of anybody who may present a prospectus purporting the existence of a splendid gold-mining property, without protecting themselves in the least by securing the advice, at nominal fees, of engineers who make it their profession to protect such investors in mining securities. This shortsightedness, and not mining proper, is the weak point. Let the general public educate itself to an appreciation of the susceptibility that is latent in everybody, and let every person exercise the same amount of precaution that makes any type of investment stable, and mining will become recognized as the perfectly legitimate business that it is.

☞ ☞

Dome Mine, Porcupine, Ontario

THE Dome Mine Co., Ltd., after a series of setbacks, started its 40-stamp mill March 21. In celebration of the event the mine and mill were thrown open to visitors and on March 29 a banquet was held in South Porcupine under the auspices of the Board of

Trade. Mr. Ambrose Monell, President of the International Nickel Co., and of the Dome mine, delivered an address which fairly bristled with common sense; and because of his knowledge of the condition of affairs in the Porcupine district, the investing public would do well to heed his advice.

That the Dome Mine Co., Ltd., has no stock on the market, it being more or less a close corporation, adds weight to President Monell's words. Mr. Monell said: "It would be idle for me to say more than that we have great belief in the future of the property, which will not be run with one eye on the hoist and the other on the stock ticker."

Naturally the men who have invested money in the Dome mine would not have done so without hopes of getting more than their money back; often in gold mining it is gotten back by unloading on the unsuspecting public; here, however, a man appears and says that he has faith in his property and if loss occurs it will not be the public's.

Mr. Monell expressed great faith in Porcupine and its future development. At the same time he advised a conservative course, pointing out the necessity of large capital for development purposes; and while his address gave abundant encouragement to the legitimate and proper development of Porcupine, it could not be construed as helpful to the gentlemen who spend most of their efforts in getting money from the public.

Such a camp as Porcupine, he said, requires time for careful development, a large expenditure of money, and after development a further expenditure for the installation of mills. Mr. Monell said that Porcupine was what was known as a rich man's camp, as it required large sums of money to be put into the ground before one could expect to receive returns. He uttered a note of warning against the embarkation in the enterprise of creating a producing property until those who embarked in the enterprise were assured by conservative engineering advice as to the amount of money required before they could expect any return. If care was exercised in this regard much loss and heart burning would be avoided, because if an enterprise is started with too little money in the treasury, first to develop, even if there be ore, then to follow that development with a mill to extract the gold from the ore, the inevitable result must follow with bankruptcy and reorganization.

He stated that capital was timid, but while Canadians maintained their reputation for even-handed justice and strictness promptly, and for the sane and sound legislation which has hitherto prevailed, they may rest assured that the capital will be bold so long as it feels that the government is maintaining a high standard of public life, whether in parliament or in the courts.

The mining industry of the United States, was very fortunate to have offered this tribute after years of mining expenditure in Canada.

The Porcupine district presents geological fea-

tures somewhat similar to some other gold districts which have proved unremunerative. However, the advantages to be derived from large investments and modern mining and metallurgy are in its favor.

栞 栞

To Decrease Anthracite Mine Accidents

In May, 1906, the Board of Examiners for the examination of applicants for the office of Inspector of Mines for the First and Second Anthracite Districts which includes Luzerne and Carbon Counties, Pa., asked the following questions:

(a) To what do you attribute the increases of accidents in anthracite coal mines, in view of the statutory efforts to place additional safeguards around the workers by increasing the number of mine inspectors and compelling a more frequent inspection of the workings?

(b) What remedy can you suggest to reduce the number of accidents?

The answer to this question which follows is as true today as when given, for which reason, and because it applies to every coal-mining community, its careful consideration is recommended.

Ans.—(a) The increase in the accident list is due to a number of causes entirely beyond the control of statutory enactment.

(1) A disposition on the part of employes to chafe against what they consider the injustice of rules of discipline enacted solely as a safeguard against accidents.

(2) A tendency on the part of mine foremen and assistants to work along the lines of least resistance by relaxing said rules.

(3) The extent to which robbing operations have been carried on in many districts, and the introduction of labor-saving machinery.

(4) The higher wages paid for the past few years in anthracite mines had the effect of attracting many men from other callings, besides a large flow of emigrants, with the result that many were injured because they were misfits in the positions they attempted to fill.

(b) Greater care on the part of the individual workman, and a higher sense of duty and moral responsibility on the part of mine foremen and assistants. Legislative enactments and official inspections cannot protect the individual workman. He should understand the dangers, duties, and responsibilities of his position, and strictly adhere to the rules of discipline and safety enacted for his protection and that of his coemployees.

Mine foremen and assistants should be animated by higher moral motives than merely obeying the strict letter of the law. They should study their duties and responsibilities, and the capability and fitness of every employe to discharge the duties of the particular notch which he fills, and fearlessly enforce all rules of discipline enacted for the protection of life and property. In collieries where these business maxims are adhered to, the ratio of accidents is greatly reduced.

栞 栞

Our Cover Picture

Our cover picture this month is typical of the haulage and coal-cutting machinery at a comparatively new mine on one of the forks of Tug River, West Virginia. That there is a decided friendship between the black man and the mule is a matter of history which this illustration verifies. Those "hay-burning mine locomotives" with their ears back have white drivers. The "Jule" mule on the left and the two with their heads together, by their peaceful expressions, show plainly their confidence in their colored drivers.

栞 栞

Correction—Anode Residues

In the article "Treating Copper Anode Residues," in the May number, the cathode analysis, in the second paragraph in first column on page 622, should read, "Copper, 99.96," instead of 99.66 as given.

COAL MINING AND PREPARATION

The Buck Mountain Coal Breaker

An Illustration of the Most Advanced Practice in Cleaning and Preparing Anthracite

The artist, the architect and the writer possess their individualities by which their respective arts are distinguished in their work. Personalities of this kind are as important to a breaker designer as to others, and it is this 100 breakers have constructed some astonishingly made by a man, or a group of men, one either with or without assistance.

The Lehigh Valley Coal Co. engineers wanted the assistance of their professional colleagues to make the project a success, and by taking in motion the most advanced practice in breaker

design, they have secured a breaker which is the most advanced breaker in operation among U.S. mines of coal today. By reference to the plan of the breaker, accompanying page 17, and the illustration, Fig. 1, it may be seen that the breaker is in a location where the coal must be raised to the very top to take advantage of gravitation in its preparation, but this feature plus the location offers the breaker a safety factor for a fire alarm. The breaker is shown in Fig. 1, in a perspective of the mine shaft in the foreground, one of the main buildings, the main shaft, and the engine house. To the right of the shaft and the office, supply, and oil houses, on the center and to the left of the latter buildings is the blacksmith shop, an oil shop, furnace, and other buildings, and a large open-air house. There are two main shafts about 700 feet deep on the property, one of them made to the breaker point, and these are equipped with air-lift pumps which raise the air under a pressure of



FIG. 1. THE BUCK MOUNTAIN BREAKER.

ing breakers which, in the writer's opinion, are the best in the anthracite fields. These new breakers are not the design of one man, but several; thus the prominent personalities of an amalgamated or disbanded, as the case may be, with similar results to the company. On the cover of the August, 1911 issue of MINES AND MINERALS there was a picture of the Mineral Spring breaker, which was visited by those members of the American Institute of Mining Engineers who attended the 25th Summit meeting in June, 1911. Evidently the arrangements inside this breaker have given such general satisfaction to the Lehigh Valley Coal Co. that it is satisfied to repeat for the Buck Mountain breaker with a few minor changes is almost a certainty, but the Mineral Spring breaker will retain its position of being the only breaker with a terraced lawn.

The Buck Mountain breaker, shown in Fig. 1, is situated on the top of the mountain about 350 feet west of the old Buck Mountain Breaker slope and about 320 feet east of the old Breaker slope near a third slope called No. 3. The object of this location is to centralize the haulages; and to this end, the three slope openings are connected by mine-car tracks on the surface with the new breaker, which will receive the coal from the three mines and prepare it for market. It is evident then that this

200 pounds per square inch. The air is raised in a compressor house to the boiler house, which contains six 200-horsepower boilers with Dixie stokers. This is a central boiler house for the three slopes, steam being carried to them in various pipes for the hoisting engines and the fans. In the mine on the bottom of No. 3 slope there is a central pumping station for all three mines. Steam is conducted from the boiler house to a bore hole and then down the bore hole to the pumps inside the mine. The column pipe from these pumps is also in a bore hole and delivers mine water to a receiver on the surface, from which it is pumped to the breaker storage tanks for the jigs and small coal screens in the breaker.

The engine house houses the breaker, breaker jig, and other cast engines.

All large rock coming from the breaker is crushed before delivery to the waste rock can, over whose tower is shown to the rear of the engine house. The crusher engine is 10 in. x 36 in. plain slide valve, drives both the waste rock can, over and the crusher.

For driving the breaker machinery, with the exception of the jigs there is a 17 in. x 27 in. x 30 in. plain cross-compound Corliss engine with pulley wheel 2 1/2 feet diameter and 24-inch face

that is belted to a line shaft high up in the breaker. From the pulley wheels on the line shaft belts extend to the pulleys on countershafts that drive the various machines. This arrangement is of great convenience as it centralizes the driving pulley belts, and the breaker machinery is placed to conform with the drive which as a unit distributes power to several subordinate

the modern high-speed fans being so much superior in construction and efficiency.*

The 18" x 36" Vulcan engine in addition to driving the fan drives a 25-kilowatt generator which furnishes sufficient electric power to light the pump station in the mine, also the breaker, engine house, boiler house, office, and yard outside. A new concrete building has just been erected for housing the No. 3 slope hoisting engine, as shown on the plan of surface arrangements, Fig. 3. Between the mule stable and the car shop there is ground space at least 180 feet long for a timber yard. Near the breaker there is a house for the rope haulage engine which hauls broad-gauge cars that have been run past the loading chute to a switch where they may be returned.

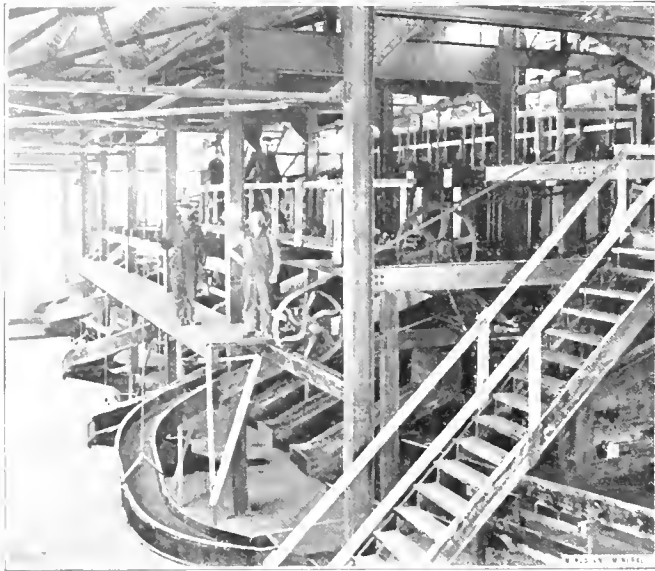

FIG. 2. JIG FLOOR

units. There is a 11" and 16" x 24" Vulcan tandem-compound Corliss engine with 9 ft. diameter fly wheel and two 64" three groove driving sheaves for driving the jig machinery. The jig shafts are connected to this engine by means of rope drives.

The tower hoist engine is a powerful duplex second-motion engine with cylinders 16 in. x 30 in. This is geared to the tower hoist drum. As all engines are in one house two men only are required for attendance, one for the hoister and one for the three stationary engines.

To the rear of the engine house is the fan house, where a 20' x 6' 8" Guibal fan is installed. In talking over the subject of fans last fall with a manufacturer, he was surprised to know that Guibal fans were still being made, particularly in view of

To describe the breaker building it is proper to commence at the foundation rather than the top, but in describing the flow of coal it is necessary to commence at the top where it is dumped, and follow it down to the cars. The surface area covered by the breaker is 90 ft. x 117 ft. with a 25' x 63' head-house. The building is 163 feet high from the top of the mine-car track to the center of the hoisting sheaves. From the foundation to the main or jig floor the pillars supporting the structure are of reinforced concrete above this floor the supports are steel columns, tied with steel floor beams, suitably arranged for the machinery and appliances. The breaker is sided to the main floor with tile. This furnishes a large enclosure on the ground floor, which on one side of the center bent will have lockers for clothes, lunch room, and bath room for the men. The other side will be fitted as a storage room for supplies. All men engaged at the mine will make use of this place to dress, eat their lunch, enjoy a pipe at noon, and to wash before going home in the evening. The jig floor is of concrete, as is also the picking floor higher up. Other floors do not extend across the entire building, a feature which furnishes light to the interior and permits inspection of the breaker machinery without difficulty. From the jig floor to the top of the breaker the siding is galvanized sheet iron with metal window frames, thus making the breaker as nearly fire-proof as possible, at the same time furnishing an abundance of light.

One of the most noticeable features in connection with the new Lehigh Valley breakers is the absence of loading tracks beneath the breaker. There is but one loading track for all sizes of coal and this is outside away from the coal pockets, thus

*See page 223, MINES AND MINERALS, November, 1911.

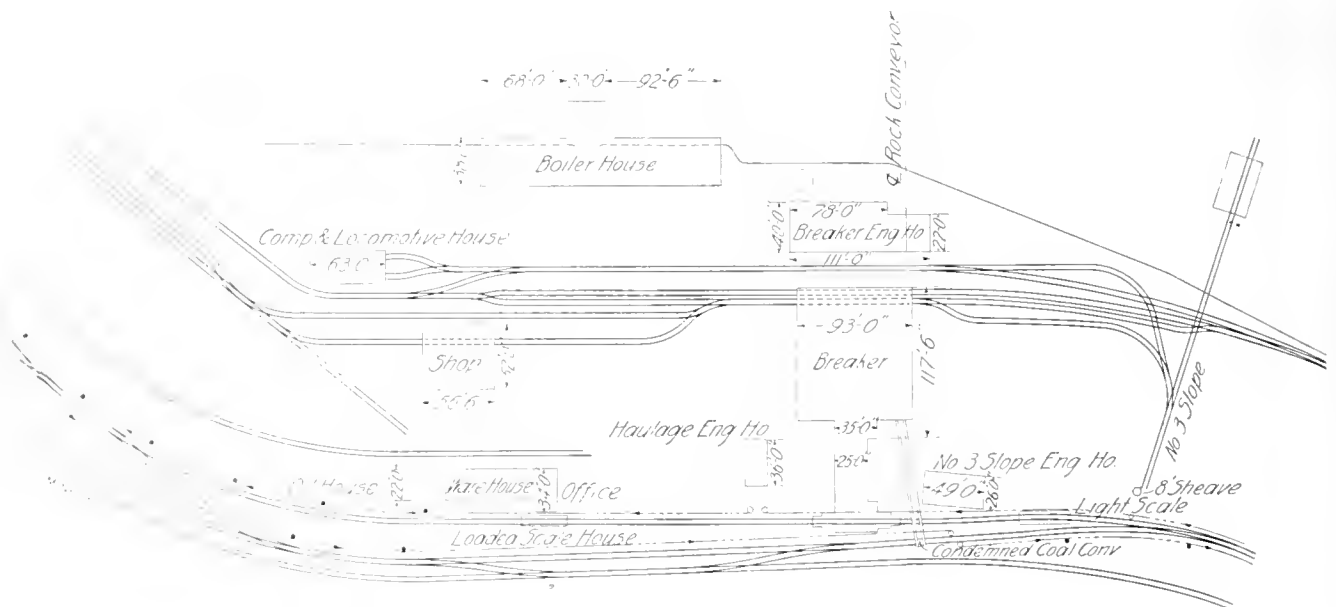

FIG. 3. PLAN SHOWING SURFACE ARRANGEMENTS AT BUCK MOUNTAIN BREAKER

making Mahomet go to the mountain rather than the mountain going to Mahomet. In case there should not be sufficient coal in the pockets of a certain size to completely fill a car, no time need be wasted in waiting for coal to be made, as the car may be run past the breaker, switched out and brought back as desired, by means of a rope haul, which in a measure takes the place of the switch engine. The rope haul is arranged to pull a partly loaded car to another track, then back to the empty car delivery tracks, so that eventually it reaches the loading chute again; or another combination might be worked which would facilitate filling the partly loaded car, and that is to side track the car and then return it to the loading chute as soon as sufficient coal has been made of the size needed. If a car contains condemned coal, it may be unloaded and hauled back to the chute where the car can be reloaded with good coal; thus it is not held out of commission and the shipment of coal delayed. The car-haulage arrangement will no doubt appeal to many coal operators.

The preparation of anthracite is a subject which is of prime importance in Northeastern Pennsylvania and therefore the following practice will be found interesting:

The coal is brought to the breaker in mine cars that are lifted by a tower hoist to the top. The two self-dumping cages are arranged to lift the car body and let that rest on the cage floor rather than on the wheels during the operation of hoisting, dumping, and lowering to the track. The mine cars on reaching the top automatically discharge their contents into a dump hopper provided with man-operated gates, worked by hand levers to regulate the flow of coal on to the dump shaking screens.

The dump shaking screens are perforated with $4\frac{1}{2}$ -inch round holes, consequently anything smaller than steamboat falls through, while lump and steamboat go over to a traveling picking table. The coal passing through the dump shaker screens slides by gravity down a chute to a second screen where large broken coal is separated from the smaller mixture and sent to the Ayres slate pickers shown in Fig. 4. After passing the slate pickers it goes to rolls where it is broken and sent to a central storage pocket. All material that passed through the second shaker screen goes to a shaking screen which separates anything larger than egg and from which it goes to rolls that crush to egg size,

picks, the coal being put back on the table while the rock is sent down the rock chute. All coal when it reaches the end of the table is comparatively free from rock and is delivered to the hopper of a pair of compound rolls that are standard with the Lehigh Valley Co. Mr. Sterling in his paper before the Ameri-

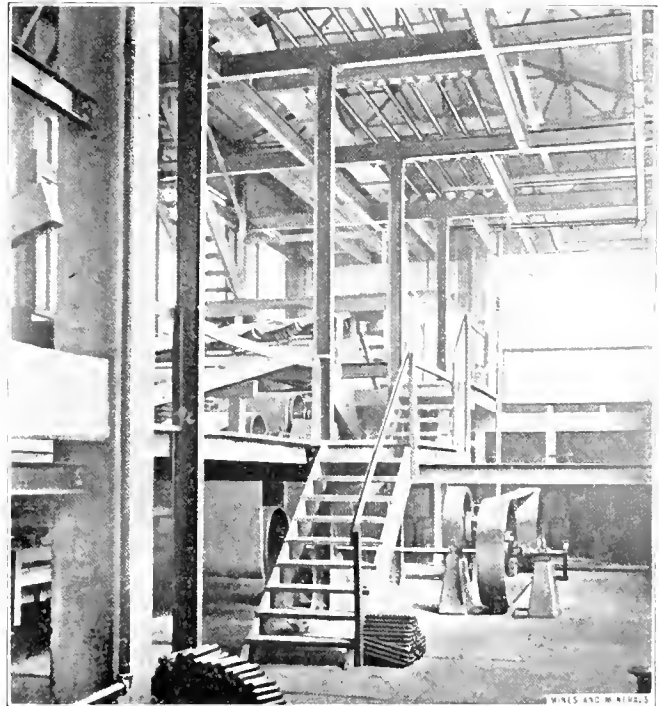

FIG. 5. LOADING CONVEYOR

can Institute of Mining Engineers, in June, 1911, gave an account of these rolls from which the following is abstracted:

"It has been ascertained by experiment that when toothed rolls are revolved comparatively slowly they do not break and shatter anthracite into small pieces to so great an extent as when revolved fast."

It requires, however, considerable power to break large coal and it becomes difficult to run slowly and obtain sufficient power to do the work with the ordinary size of rolls and gears. To overcome the loss of power due to speed, the Lehigh Valley Coal Co. compounds its rolls; that is, the large gears on the roll shafts are driven by a small pinion on another shaft, thus reducing the speed of the rolls, yet retaining sufficient power to do the work. It is claimed by Mr. Sterling, that, with this system of roll driving, chilled cast-iron teeth, which cost less than steel teeth, can be made to wear equally as long. There are other good features in connection with these rolls worthy of mention; for instance, the roll body is eleven sided and grooved on each side so as to form a dovetail with the toothed segment. This arrangement takes the shearing strains which come on the bolts that fasten the segments to cylindrical drum rolls. The rolls are housed with cast iron and steel and the gears are covered in order to prevent accidents to the men.

The rolls are coarse at the end of the picking table and their product is delivered to a shaker, which separates egg and smaller sizes from the coarser broken coal. The broken coal passes over the screens to a pair of rolls which break it to egg size after which it goes to the central storage pocket. The egg size and smaller which passed through the screen goes direct to the central storage pocket. All coal is now egg size and smaller in the central storage and is fed from it by four rotary feeders on to four banks of five-decked screens, which make egg, stove, nut, pea, and buckwheat sizes, that go from their respective screens by the chutes shown in Fig. 2 to the jig pockets. The fine material which passed through the buckwheat shakers goes to other

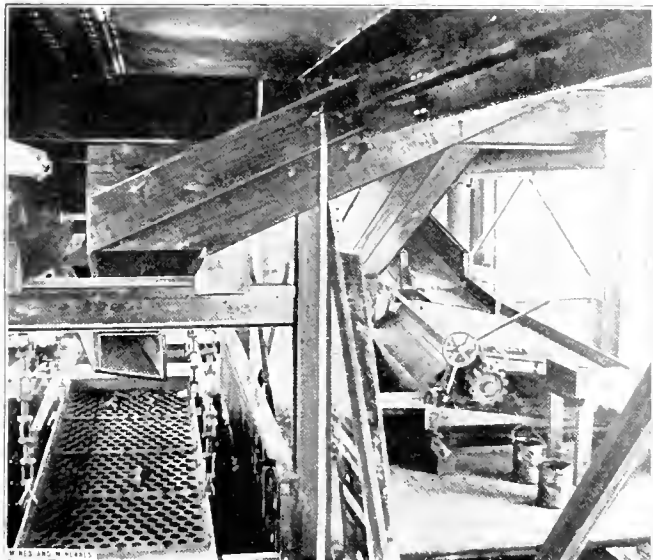

FIG. 4. SHAKING SCREEN AND SLATE PICKER

and thence to the central pocket. The material from this screen, which is egg size and smaller, goes to the same central pocket; thus after sizing and breaking down, the product is mixed. The coal and rock going over the dump shakers to the picking table are hand sorted; rock is pulled off the table and sent by chute to the rock bin above the crusher; rock and coal are separated by

shakers where it is sized into rice, barley, and slush. Rice and barley coal are used for steam under the company's boilers, while the slush flows to the ash pits under the boilers and is washed out with the ash waste.

There are 20 standard Lehigh Valley jigs, arranged in two rows of 10 each side of the center line of the breaker. Each jig will have an average capacity of from 8 to 12 tons per hour, depending upon the size of the coal treated.

The Lehigh Valley jig shown in Fig. 6 is of the plunger type with a perforated jig-box floor. As the piston is thrust down

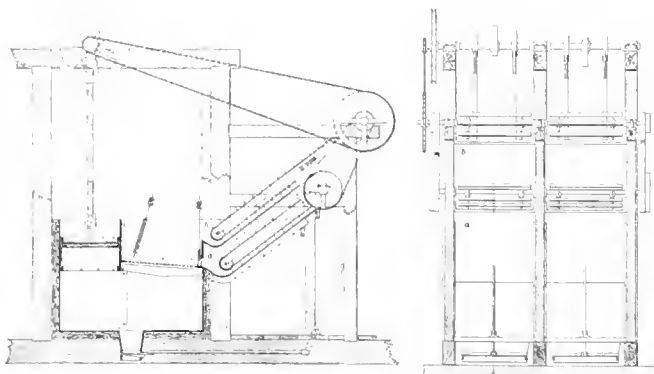

FIG. 6. LEHIGH VALLEY JIG

by the eccentric on the driving shaft the water is forced under the jig box and up through the floor into the box, thus raising the mixture of coal and slate. The coal, being lighter than slate, floats higher in the ascending current of water, and on the return, or upstroke, of the jig plunger, the slate being heavier falls faster than coal. By a series of pulsations of this kind the coal and slate separate in layers, and as fresh material is fed on the jig floor back of the hopper in the jig box, eventually so much material gathers that the coal runs over the lip and is carried out of the jig by the conveyer *b*; the slate falls through the gate to the jig hutch from which it is lifted by the elevator *a* and sent by scraper line to the waste-rock bin. There is a lip screen on each jig which removes the small pieces of coal that are made after passing the buckwheat screens. This with the fine coal made in jigging is sent to the jig slush shakers where it meets the slush from the barley screens before it flows to the ash pits. The fine coal from the jig slush shakers is carried by an elevator to the central storage bin and sized with fresh coal.

Although the slate gates can be regulated so that the slate and coal discharge will be uniform and automatic, the jigs will require some attention to see that they are working right.

From the jigs the coal goes by means of waterfall chutes to the coal pockets which are constructed of reinforced concrete and arranged in two rows with gate chutes facing a Robins endless-belt conveyer that is central between them.

The engine for driving this conveyer is shown in Fig. 5 to the right of the stairs leading to the loading platform. The conveyer belt passes down over an idler, then half way round the driving pulley and up over the top of another idler to the pockets. The loaded belt travels on the conveyer rollers shown above the idlers and delivers its burden to a telescopic loading chute supplied with a lip screen for removing the fine coal made between the jigs and the loading chute. This coal is carried by scraper line to an elevator which returns it to the central storage pocket for resizing. When it is desired to load a certain size coal, the car loader opens the gates to the pockets by means of steam, and there are two pockets for each size of coal and the Robins loader, when he is able to load a car quickly. In case a car of coal should be condemned by the inspector it is run to where there is a hopper under the track and unloaded. From this hopper a scraper line will carry the coal to the elevator already mentioned for re-screen coal, and the coal will be lifted to the central coal pocket and be prepared.

Several features in the preparation of coal at this breaker are worthy of notice since they are radical departures from the older methods of wet preparation and materially simplify the process of preparation.

It is the custom usually to make two kinds of coal, that passing the dump shakers or mud screens being called dirty coal, and the lump passing over the picking floor or belt being called clean coal. After these two products have been kept separate through the preparation period they are then combined and loaded into the same car for market.

In this breaker there is no attempt made to separate dirty from clean coal; in fact no pure coal preparation is undertaken, as both kinds—dirty and clean—are broken to domestic size and landed in a central storage pocket from which place they are prepared together. This arrangement naturally furnishes a uniform shipping product.

Another feature which will seem odd is the absence of boy slate pickers and the customary mechanical slate pickers. With the exception of the Ayres pickers all separation of slate and coal is accomplished by jigging.

The practice followed simplifies the preparation; decreases the number of machines and therefore repairs; is economical in labor; and, all told, is a long stride toward a reduction in the cost of preparation, and in the loss due to breakage of coal in the course of preparation.

MINES AND MINERALS here acknowledges the courtesy of Lehigh Valley Coal Co. officials for permitting its representative to rove around the Buck Mountain plant, to Mr. Underwood, district superintendent, for his kindness in showing him the breaker, and to Mr. Paul Sterling, mechanical engineer, for his kindly courtesy in going over the article and accurately describing the course of the flow of the coal through the breaker.

乘 乘

Boiler Coal Elevator, Navajo Mine

Economy in fuel is now practiced as much at coal mines as in other manufacturing enterprises and various plans for utilizing what would otherwise be waste are made use of.

At the Navajo mine, at Gibson, near Gallup, N. Mex., the slack for steam making is elevated to the level of the tippie plat-

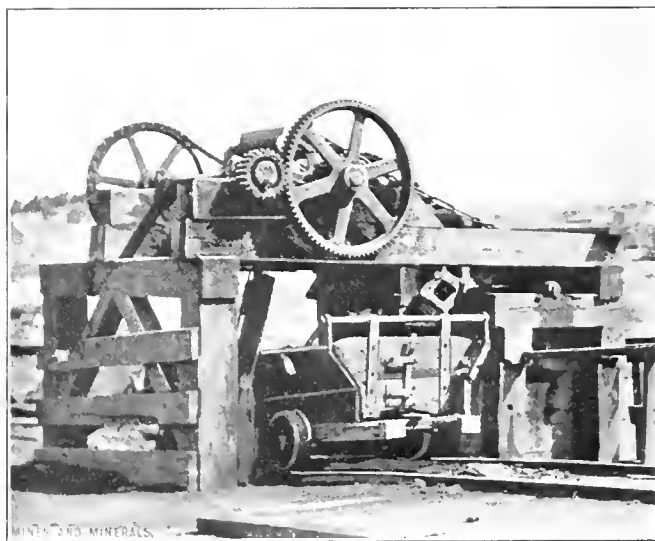

TOP OF BOILER-COAL ELEVATOR, NAVAJO MINE

form where it may be loaded into mine or special cars running by gravity to the boiler house, in place of switching out from the regular trip one or more cars loaded with mine run or lump; this arrangement is economical in labor and enables the use of a lower priced material for fuel. The top of the elevator used for this purpose with the car in place for receiving the slack is shown in the cut.

Hydraulic Filling in European Mines

The Dry Filling Method Formerly Used in Silesia and the Hydraulic Methods Now in Use

By L. Bucherer

Hydraulic filling was used for the first time in the Laurel Hill mine, of Ario Pardee, at Hazleton, Pa., in January, 1889, and at the beginning of the present century it was introduced into Europe in the mines of Silesia for the purpose of strengthening the pillars under the inhabited centers.

This method of preventing the surface caving came into general use when the material for filling was found not far from the mine. It is now used in potash, salt, and iron mines, but only in the coal mines has it reached development worthy of description.

Its introduction to the mines of France, Belgium, Austria, and Westphalia is not universal, as its adoption depends on the existence of proper filling material, while in Silesia, Hungary, and the southern part of the district of Saarbrucken, this method has been generally adopted because of the great abundance of suitable sands.

This hydraulic filling method which for lack of a better word is called "silting," is most developed in the Klein-Rosseln mine (Lorenc), not so much for the amount of work that has been done (in some of the mines in Silesia where they work veins of great thickness, and in some lignite mines, they have done as much of this work or even more) as for the different cases in which it is applied and the great importance it has acquired in the general working of a complicated and dangerous mine in which the labor has become highly skilled.

The following is an abstract from L. Bucherer's paper in *Ano II, No. 6, Informes y Memorias del Instituto Mexicano de Minas y Metalurgia*, which was translated for MINES AND MINERALS:

The Klein-Rosseln plant consists of six mines with two shafts each. In 1910, 5,000 to 6,000 tons were mined daily, working 15 coal beds in each mine and employing about 7,500 men.

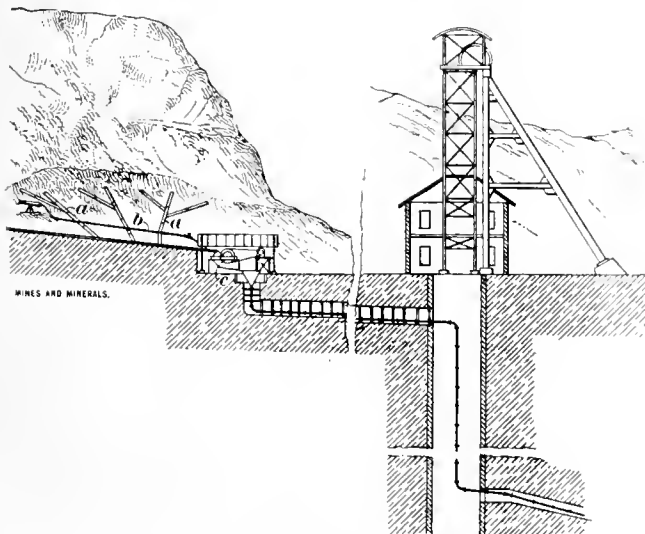

FIG. 1

The surface above the mines is covered with extensive sedimentary deposits of sandstone, gravel, clay, and hematite, but not being very strongly cemented, it separates easily and makes a good material for the hydraulic filling.

The coal beds are near one another and vary in thickness from .80 meter to 8 meters.*

The ground between the coal beds is almost always in very

* 1 meter = 3.281 feet.

bad condition, therefore causing many difficulties in the work. Furthermore, there is much gas in the mines and one must guard against spontaneous combustion.

For all the above-mentioned reasons, hand filling has been followed for 40 years, using for this purpose the refuse from the mine and taking material inside from the outside.

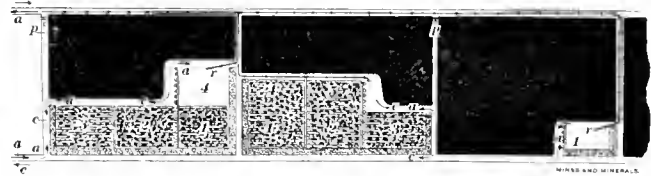

FIG. 2

To give a proper idea of the changes that the hydraulic filling brought about, it is necessary to explain how the work was carried on before its introduction.

The coal could not be mined without completely filling the excavation made, because of the bad condition of the overburden, therefore it was necessary, because of its importance, to employ one force of men for filling, another for the extraction of the coal, and a third for the repair work.

For the transportation of the great quantities of filling material, it was necessary to have a bin in the upper chambers and to keep the gangways in good condition. These gangways were in constant need of repair and required a force of men who devoted all their time to this work. The principal gangways that were used, first to transport the coal to the shaft, and afterwards to transport the filling material into the works could not be arranged to transport the coal properly and to drain the water.

For the work of filling, several hundred men were needed, who had to be selected from the youngest and strongest on account of the hazardous work, and they took advantage of every opportunity to ask for increase in pay and better conditions, so that they were not only lost for the productive work, but they formed among the workingmen a nucleus of discontent. Another difficulty consisted in the absence of older and more experienced men to look after these daring and inexperienced youths, especially in a mine that was so dangerous because of the falling rock and presence of gas.

As the coal beds were so near one another, it was impossible to begin work on a new bed before having completed the filling in of the upper or lower one, and this required many months because of the compressibility of the hand-made filling. The result was that the workings covered a wide area and necessitated working several beds at the same time, which caused great delay in the transportation and made the ventilation more difficult, and finally increased the general expenses.

The adoption of silting in 1904 caused a complete change both in the exploitation and in the transportation, and little by little, new processes and methods were adopted to meet the new conditions. It was found that the silting did not constitute a universal method, that it could be applied only in special cases, and that hand filling must continue in many places. Sometimes a combination of both systems will secure the highest economical and technical efficiency.

Silting, which is considered as the most important advancement lately introduced in coal mining, has the following advantages: The mining is carried on by two shifts working 8 hours, and by three shifts when there is great demand for coal; and this increase in production could not have been accomplished with the old system of hand filling. In every one of the six mines about 100 men form the productive working force; and as the beds were worked more rapidly and with less interruption, the output increased, and the wide extensive working area of the mine was largely reduced, until the production was concentrated on one level and the transportation accomplished by means of locomotives.

The mine fires, so prevalent with the hand filling, disappeared entirely, and the ventilation, so important in the mines, was greatly simplified.

These are especial advantages for a coal seam 8 meters thick, which is worked in four benches. With the hand filling a great deal of timber was used for propping, and it was always dangerous, as the props might give way on account of the gob sinking, and the last bench worked was often almost entirely pulverized, and consequently the coal of very poor quality.

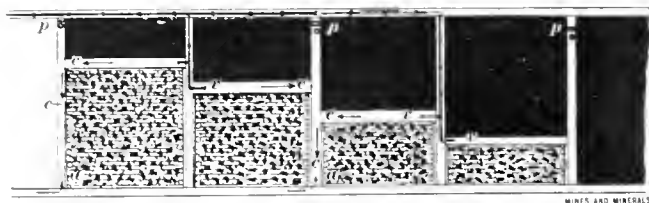

FIG. 3

With silting, hardly any difference was noticed in the quality of the coal in the upper benches and the others, the coal being so hard that sometimes it required shooting.

A general advantage for the mine resulted from the decreased number of falls inside and in the caves on the surface, and the consequent lessening of damages to be paid and repairs to be made on inhabited houses.

However, this silting system is not free from many defects.

On one side of the ledger, the amount of timber consumed in the mine was diminished, but the other side showed that a great deal was used in the forms for retaining the filling. Furthermore, the lower ends of the props became rotten where the water ran, and it was necessary to treat a part of the timber with wood preservatives. The water that worked through the rocks above increased the pressure on the supports, so that in many places it was preferred to keep on with the hand filling. In the thin seams the dampness affected the workmen so much that it was also advisable to keep to the old system there. To all these inconveniences must be added the complications caused by the pipes for carrying the filling and for the drainage; also it was necessary to enlarge the electric plants, to install new pumps, and take special pains to clarify the dirty water.

In spite of all the hopes at the beginning that hydraulic filling would reduce the cost of mining, it has been proved, by the experience of several years in mines using this system, that this is not to be, except in extraordinary cases. By the silting method, double the amount of filling material is introduced in the mine over hand filling, but deterioration of the distributing pipes quickly takes place.

However, generally speaking, by silting a number of economic advantages are obtained if the concentration of work, the increase of the output, and the reduction in surface caves are considered. Probably the greatest advantage is in the reduction of the general expenses.

Silting increases the value of the mine, because of the possibility of taking out the pillars under towns, railroads, lakes, foundries, etc. It is calculated that in upper Silesia about 30 per cent. of the coal was left unmined, and that at the "Koenigin-Luisen Grube" mine, the silting system will furnish an increase of 68 million tons of disposable coal, which represents a value of 700 million marks.* It is reported that in the German Empire the national wealth in unmined coal left in pillars to support the surface and which may be mined now, increased several millions of marks. Silting is not only an improvement in the art of mining, but it constitutes also an absolutely new process for solving new problems.

At the beginning, the hydraulic filling was used only to fill some special places. In most cases material for flushing was

* A mark = 23.8 cents.

taken into the mine dry, and when in close proximity to the work it was mixed and poured into the rooms.

For filling on a large scale, this method was not advantageous, because all the methods of the dry system were applied, for which reason it was decided to do the mixing outside, and carry the material by means of pipes into the workings to be filled. Great efforts were made to devise special apparatus, particularly by machine manufacturers, who saw in this a good opportunity for business. As these devices were made by men who were not mining experts, they proved fruitless, although they are used in certain mines. In their design it was completely ignored that in mining the simplest devices are always the best.

In the above case, the best method was that applied in Pennsylvania, which consisted in silting the materials into the mine by means of water. This was the system applied in the Klein-Rosseln mine from the very beginning and was afterward employed almost everywhere in Silesia.

The best installation that can be devised in the majority of cases is that of the Klein-Rosseln shown in Fig. 1. The gravel is blown out of a semicircular quarry by means of powder, and a net of sluices *a* with an inclination from 8 to 10 per cent. is spread, as well as a set of pipes *b* of 100 millimeters thickness* for conveying the water under pressure. The pipes terminate in nozzles having a diameter of from 4 to 5 centimeters at the discharge end. Hydraulic pressure for the nozzles is obtained from tanks placed so high above the discharge as to furnish a pressure of from 80 to 125 pounds per square inch, or else from centrifugal pumps. The water issuing from the nozzles breaks up the material and washes it through the sluices. The material in the sluice contains hard stones, the refuse from the coal, as well as the cinders from the boilers, therefore it is necessary to break the big pieces that would fill up the pipes going into the mine.

The mixture before going into the pipes passes through crushers *c* through which 400 cubic meters* of mixture and 100 tons of big pieces may pass per hour. These crushers are worked by a 20-horsepower motor and break stones into pieces of 5 centimeters. Then the mixture passes through a screen with holes 7 to 9 centimeters, which is intended to retain the large pieces that have passed through the crushers, especially pieces of wood, roots, etc., which would certainly fill up the pipes.

A special watchman attends to this work which requires much practice and watchfulness in order to be carried on without interruption.

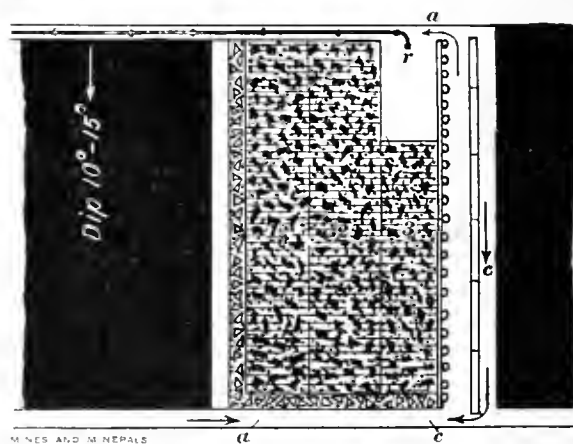

FIG. 4

Before beginning and after ending filling operations it is necessary to flush all the pipes with clean water, so as to sweep out all residue in the elbows and horizontal parts which are very often a cause of stoppage.

A general idea of the arrangement of the mine and of the methods of mining employed with the hydraulic filling is given.

* 1 millimeter = .03937 inch. 1 cubic meter = 1.308 cubic yards.

The seams are classified as steep pitching, moderate pitching, from 15 degrees to 40 degrees, and those of little inclination or comparatively flat, say less than 15 degrees.

In silting, the first two cases do not present any special difficulty, while for those of little inclination the method is not very good. The moderate pitching beds are the most favorable.

The essential principle consists in excavating the coal by any method in a certain area, depending on the solidity of the roof, and building about the cavity wooden or rock walls, but leaving a free passage for the air and the men. This enclosure may be filled up with the mixture that comes through the pipes. Care must be taken to draw off the excess water from the forms so as to leave only the solid material.

The most common method of working is shown in Fig. 2.

The preliminary work of the mine is done in two beds whose distance is determined by the most practical length of the inclined planes. On each layer pipes are opened which are connected by inclined planes. Generally the mining is carried on along the limits of the mine; however, the only reason for not opening before reaching the limits and working the mines coming back, is that the working of a new level is delayed.

Fig. 2 shows the method generally called Stossbau, which, in spite of having been first applied with the hand-filling method, became a feature of silting.

The arrows *a* show the direction of the air-currents, *r* shows the pipes, and *c* the direction the coal is moved to the bottom of inclines *p*.

The inclines *p* are generally from 50 to 60 meters from one another, every other one being devoted to the transportation, the middle one being for the pipes and the men. The numbers 1, 2, 3, 4, and 5 on seam show the succession of the fillings, when the height of the seam does not allow a complete slice being taken off between two inclined planes.

In this way the silting method shown in Fig. 3 is carried on. The preliminary work is done at the same time as that of mining, and the air-currents take the shortest and easiest route. In this figure *v* represents the pipes.

In some cases the system is modified in a simple way that would be impossible with any other system. It consists in making the pipes pass along the same level, closing completely the way to the upper level, which is always found in very bad condition and is often abandoned when beginning to mine the new level. Furthermore, we must consider some reasons that were decisive in several cases: every time a slope that is being worked goes over or under one of the other seams, or every time that workings on the same seam approximate a distance of 10 to 20 meters, important expenses for the repairing of gangways are incurred.

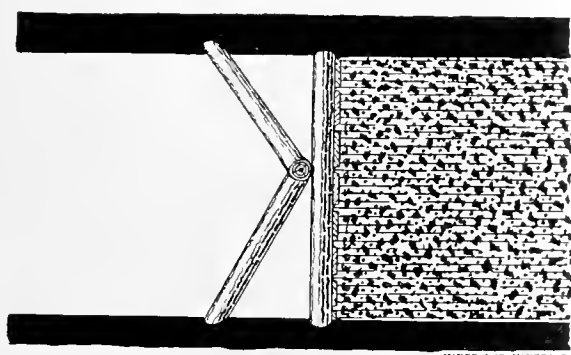

FIG. 5

The silting method is the simplest and gives the highest output for a given area and when a great demand for coal exists it has been possible to work several months with three shifts of men.

When the coal seam is from 1.80 to 2 meters thick, and is mined by undercutting, the excavation does not produce all the

filling material that is needed for hand filling, and when the seam is sufficiently uniform, the method of silting shown in Fig. 4 is followed because it allows a new bench to be mined in short time. The method consists in connecting as quickly as possible the two levels by an inclined plane. If the inclination is less than 15 degrees to 18 degrees, the face must be occupied by a force of 20 or 30 men so placed that each has a working space of about 3 meters. At a distance of 1.5 meters from the face a car propelled

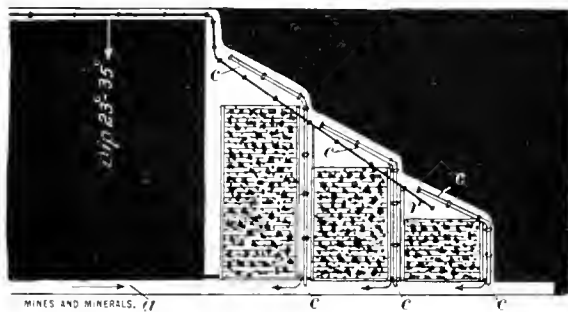

FIG. 6

by a 5- to 10-horsepower motor is able to transport about 30 tons of coal per hour. One meter behind the track a wooden battery is built, covered with jute cloth through which the water may seep. According to the conditions of the high back, from 3 to 6 meters along the shaft will be left open and the complete space will be filled by silting from two to four times, according to the permeability of the material, the object being to give the lower layer of filling time to dry, and so prevent a strong pressure on the lower part of the battery.

The lumber and the cloth on the battery are taken off when the filling is dry and are used again for the next battery. Fig. 5 shows the method of battery construction.

When the natural conditions of the ground are favorable this method gives very good results in spite of the output of each man being less than that of gangs of three to four men, for the attention and diligence are not the same when 20 men are doing the work as when two or three do it. However, on the other hand, the advantages must be considered, namely, the simplification of the work, the concentration of a large output in the same place, the reduced extension of the roads, and finally the good ventilation, which in coal mines is always a question of great importance.

Here we are confronted by conditions that had been overlooked for many years in mining. Whenever the inclination is greater or whenever the seam is so thin that the workings will produce enough refuse for the hand filling the conditions favorable to silting change altogether. In this case hydraulic filling is not to be recommended, for hand filling is more economical.

When a seam is thin, of steep inclination, and with a good roof, it is better to work upwards, especially when the coal cleavage has a favorable direction.

The coal is sent down in semicircular chutes, as in Fig. 6, and care must be taken to keep them filled in order to prevent the coal from breaking on account of the velocity. The pipes for silting go down the same incline and the filling can be carried on without interrupting the mining. Every 12 meters an incline is left open in the filling for the chutes and the flushing.

One disadvantage of this method consists in the heavy timber expense. It is not convenient to adopt this system when there is the least danger of pressure, for the noise in the pipes prevents the men from hearing the noise that announces a sinking from above. However, this method, when properly applied, gives good results, with a large output of coal, especially when the seam contains a certain quantity of slate that may be used to make batteries 2 meters wide and so economize in the timber otherwise needed.

Antitrust Laws and the Coal Industry

Producers of Bituminous Coal Prevented from Taking Needed Steps for Mutual Protection

By Glenn W. Traer

The sale and distribution of coal in the various coal producing states is in part subject to the provisions of the Federal antitrust statute, commonly known as the Sherman act, and in part to the provisions of the antitrust statutes of the respective states. The Sherman act applies to sales of coal for shipment into other states. The state laws apply to sales for local delivery or for shipment to points within the respective states. The mere production of coal, as distinguished from its sale and shipment, is governed by state law alone. Discussion of the federal statute alone does not give one a clear understanding of the insurmountable difficulties which confront bituminous coal operators under present laws. Because of limited time and my greater familiarity with the law and facts in the state of Illinois, I shall confine myself to Illinois references in discussing the local phases of the subject.

Let us set out briefly but clearly those provisions of the Federal act and the Illinois act which are pertinent to this discussion. These quotations follow the exact language of the two statutes respectively, except as to the omission of words and expressions which are superfluous to this discussion. Both the Federal and State statute impose harsh penalties for violation of their provisions.

The Sherman act provides:

"Sec. 1. Every contract, combination * * * or conspiracy in restraint of trade or commerce among the several states or with foreign nations, is hereby declared to be illegal" (and such contract, combination or conspiracy is declared to be a misdemeanor).

"Sec. 2. Every person who shall monopolize or attempt to monopolize or combine or conspire with any person to monopolize any part of the trade or commerce among the several states, or with foreign nations, shall be deemed guilty of a misdemeanor * * *."

As now construed by the Supreme Court of the United States, this statutory condemnation of monopoly and of restraint of trade is about the same as the common law condemnation, with statutory penalties added. Statutory law comprises all laws enacted by legislatures or by congress. The common law comprises the rules and principles, not incorporated into statutes, adopted and established by courts in their decisions upon questions not covered by statutes. The systems of law of the several states comprise the common law, but the federal system of law does not. The common law merely made void, as between the parties thereto, contracts unreasonably restraining trade or tending to create monopoly. No punishment was provided or penalty imposed. The substance of the common law relating to monopolies and restraint of trade with penalties added therefor was enacted into the Federal law by the statute we call the Sherman act.

Stated more briefly the Sherman act prohibits—

(a) restraint of trade with other states or foreign nations, by means of contract or combination, and

(b) the monopoly of or attempt to monopolize any part of trade or commerce with another state or with a foreign nation, by any person or combination of persons.

These prohibitions regarding monopoly or the attempt to monopolize are about as definite as is practicable. In fact, monopoly will be rarely if ever literally absolute, and it would be impractical to fix by statute, percentages or degrees which should be necessary to constitute unlawful monopoly. The conduct of the person or persons charged with the alleged offense and the results they accomplish must determine their guilt or innocence, in the usual course of the administration of justice. Cases which

arise will be settled in the due course of affairs and uncertainty as to the future settlement of specific cases not yet arisen need not paralyze or discourage effective organization in different lines of business.

But "restraint of trade" is a far less definite expression. It may be held to condemn many things not at all of the character or effect believed to be inevitable under practical monopoly, and because of which monopoly always has been feared and condemned. The Supreme Court of the United States has held that this prohibition must be construed "in the light of reason." If this is intended to mean that only those acts in restraint of trade are to be condemned which are of the same character as the acts feared from monopoly and therefore injurious to the public as a whole, it is unfortunate that it has not yet been so stated by the courts of last resort. Indeed if that is what is intended it is difficult to understand why the Federal statute might not be safely amended to that effect.

The Illinois antitrust act provides:

"If any * * * individual * * * shall * * * become * * * a party to any * * * understanding with any other * * * individual, to regulate or fix the price * * * of any commodity; or shall * * * become * * * a party to any pool, agreement, contract, combination or federation, to fix or limit the * * * quantity of any * * * commodity to be * * * produced or mined * * * in this state, such * * * individual * * * shall be * * * guilty of conspiracy to defraud * * *."

Before the enactment of the antitrust statute in Illinois, the general prohibition of monopoly and restraint of trade rested alone upon the common law of the state. But the common law left some things to reason in its application to alleged facts and it did not provide accompanying penalties as for criminal misconduct. Therefore the Illinois statute quoted was enacted in which the use of general terms like monopoly and restraint in trade is avoided and the practical things most feared in and most likely to result from a monopoly, namely, fixing prices and limiting output, are designated with admirable clearness and prohibited under harsh penalties.

Stated more briefly the Illinois antitrust act prohibits:

(a) any form of understanding, between any two or more persons, to fix the price of any commodity.

(b) any form of agreement, between any two or more persons, to fix or limit the quantity of any commodity to be produced.

With this review of the law in mind turn now to a statement of facts relating to the coal-mining industry in the state of Illinois. Almost three years ago I had the honor of addressing the American Mining Congress in the city of Pittsburg, and in the course of my remarks described the conditions of the coal-mining industry in Illinois. The demoralized and economically unhealthful conditions then described still exist and much of the language then used still fits the case.

There are about 300 independent coal producing companies in the state, operating more than 400 rail shipping mines. A tremendously rapid expansion of mining capacity has been made possible by the extraordinary cheapness at which a body of coal lands could be purchased, from owners usually retaining the surface, and the ease with which transportation facilities are extended in a prairie state, and access given to large, but deceptively alluring because already overfilled, markets. Public necessity seems to require that there shall be in existence at all times sufficient mining capacity to supply the requirements of the winter months. This inevitably means a large surplus capacity in the spring and summer months. But all reason has been exceeded in that respect. The aggregate annual capacity of Illinois coal mines is so much in excess of the aggregate annual demand for Illinois coal that the average running time of all mines does not now exceed 180 days per year. The natural fluctuation in the demand for Illinois coal between summer and winter is such

that the industry never can expect to work full time. While Illinois coal can be stocked a considerable length of time it cannot be mined many months in advance, and held for use in the winter like anthracite and more expensive eastern bituminous coals, because it contains a higher percentage of moisture and will crumble and slack sooner than the higher priced coals. Consumers of Illinois coal aggravate, rather than help to overcome, this condition by refusing to order coal as far as might be in advance of the actual need for it. It must be produced substantially as ordered from time to time, and this makes production or demand (and demand and production mean the same thing in this connection) much less during the months of April to September, inclusive, than during the other months of the year. This condition is so uniform that the relative percentages of production during the busy season and the duller season have not varied materially in 10 years except when temporarily affected by anticipation of a strike or other abnormal business conditions.

For several years the margin of capacity over and above summer requirements has been greater than is necessary to properly supply a normal busy season. For the reasons given it never could be hoped reasonably that the mines should average full running time excluding only Sundays and holidays. But after making all due allowances it is fair to say that the excessive producing capacity results in an average loss of 60 days per annum for all mines, compared with what might be properly expected with a reasonable adjustment of the number of mines attempting to run to the number actually required to fully and promptly supply all demands.

There are more than 70,000 miners and mine laborers at the mines in Illinois, working on the average 60 days per year less than they could work if there were a reasonable adjustment of producing capacity. This is equivalent to the absolute idleness for the entire year of 12,000 to 15,000 men. This is an enormous economic waste. Many miners are held in the industry working short time, with resultant low annual earnings, when their labor might be usefully applied in other industries where it is needed. Many less miners could produce all the coal required and enjoy much larger annual earnings.

The excessive number of mines kept open for operation causes a scarcity of miners, makes miners much harder to get, more difficult to deal with, and makes it necessary to accept the services of inferior miners, when, if fewer miners were required, operators could choose the better class, which the miners themselves desire shall be done.

The very low average number of days' operation causes coal to cost much more than it would if fewer mines were operated a greater number of days; and the natural endeavor of each individual company to secure a greater number of days' operation than the average, depresses the selling price of coal to cost or less, in an effort to avoid an almost certain greater loss by voluntarily accepting a lesser one.

The intense economy forced upon the mine owners by these conditions is seriously affecting the proper conservation of the coal deposits.

The general population of the communities in which coal mines are located as a rule are suffering greatly in their business affairs. These conditions are suffered by every one dependent upon the industry, while the consumers of Illinois coal as a general rule are buying the coal at the cheapest prices in the world. The average price at the mines for bituminous coal used in Chicago and St. Louis is cheaper than in any other of the great cities of this country. The prices paid for Illinois coal by transportation companies and industries is less than half the price paid for coal for similar uses in Great Britain and on the continent of Europe. I am informed by coal operators in other states that similar conditions prevail with them.

Such conditions in a great industry are a public evil, not a public benefit, even though they result in lower prices to con-

sumers than would prevail under an intelligent organization of the industry.

It would be perfectly justifiable morally, to shut down the surplus mines during the spring and summer, provided enough mines were kept open to adequately supply the public requirements during that period. But in such a disorganized industry, selfishness prevails apparently without thought of or regard for the future. Human nature would act the same in any other industry, under like conditions. Immediate self-preservation is the natural instinct; not present self-sacrifice for the chance of possible future benefit.

If a coal mine stands idle, physical deterioration proceeds with great rapidity. In many cases large quantities of water must be pumped out constantly or the mine will be flooded and destroyed, while in others underground fires from spontaneous combustion must be guarded against constantly. A very heavy additional penalty is thus imposed upon the mine owner who might otherwise choose to let his mine remain idle instead of producing and selling coal at a direct loss.

The theory upon which the condemnation of monopoly is based is that it creates a false relation of inequality between buyer and seller, gives the seller an unfair advantage and enables him to secure from the buyer an unfair price; a price greater than is necessary to yield a fair and reasonable profit, and greater than could be secured if the relations were fair and equal.

The theory upon which the condemnation of restraint of trade is based is that such restraint is injurious to the public. But, does the public consist solely of buyers and consumers?

Doubtless there are those who will say that if producers know no better than to waste their capital, efforts, and time in mutually destructive competition, nevertheless the public generally profits rather than suffers by their conduct, and that it is no part of the public duty or interest to conserve the property and interests of people who lack sufficient judgment and self-control to do so for themselves. I do not believe that such a position is economically sound, or creditable to the individual who assumes it, with reference to any kind of industry or public service. But in connection with the production of coal it is particularly unsound. Industries engaged in production or manufacturing based upon raw materials which are reproduced periodically stand on a different footing than those engaged in the production of coal. The conditions of waste and loss exist in a greater degree and are less reparable in coal mining than in ordinary industries; and there is also the irreparable waste of an exhaustible and irreplaceable natural resource, which is indispensable to the continued existence of modern industry and civilization.

But, it may be asked, how can you prevent the excessive investment of capital in a given industry during or following a period of unusual prosperity in that industry, and thereby prevent the waste consequent upon such overcapacity; and it must be answered that it cannot be entirely prevented. But it may be greatly modified by a reasonable regulation of production. To illustrate: A period of extreme depression causes the permanent abandonment of old mines and a greater loss of aggregate capacity than is replaced by new mines, of which there are few if any opened. The history of the industry discloses that when prosperity returns demand for coal increases with far greater rapidity than producing capacity can be increased, because it requires from 1 to 2 or 3 years according to location and natural conditions, to open and develop a new mine. The rapidly growing demand soon overtakes the weakened capacity. Consumers bid prices up on themselves and the industry is quickly in a state of abnormal and excited prosperity. Inexperienced and deluded owners or borrowers of capital rush into the industry. The judgment and foresight of experienced men frequently is overborne by the lure and excitement. In a few years the increasing demand slows down and later even shrinks again. In the meantime the abnormal increase of capacity overtakes and passes

demand and the periodical collapse and depression again sets in. It is a superficial comment and merely begs the question to say that this occurs in all industries and cannot be avoided without changing human nature. Moreover in the production of coal it occurs with much greater than the average intensity and as I have endeavored to point out, results in greater harm to the public welfare. The real question involved is whether an attempted cure may not aggravate the disorder or work harm to the public in other directions. It will be urged that artificial maintenance of prices against natural reaction from unnaturally high levels, will only delay the reaction temporarily and intensify it when it occurs. Again this is merely begging the question. The solution which should be sought for should be one which, by checking the unnatural severity of the depression, will to the same extent check the abnormal reaction following recovery. An intelligent regulation of attempted production during periods of depression and excess of capacity would tend to lessen the actual loss of producing power, and by a greater readiness to meet and supply a rapidly increasing demand, following recovery from depression, would in turn prevent an excessive increase of capacity. But such a policy cannot be carried out by cooperation among mine owners under present laws, as now interpreted by the courts, with any reasonable certainty of escaping prosecution, even though reasonably disinterested persons could see in the results effected no practical harm to the public interests in general.

乘 乘

1911 Bituminous Mining Law of Pennsylvania

In the April number comments were made on the differences between the old and the new law shown in the first four articles:

ARTICLE V.—DUTIES OF FIRE BOSS

SEC. 1. "In such portions of a mine wherein explosive gas has been generated within 1 year before the passage of this act, or shall be generated after the passage of this act, in sufficient quantities to be detected by an *improved safety lamp*, the mine foreman shall employ a fire boss or fire bosses, * * *." The old law (Article V, Sec. 2) stated " * * * in sufficient quantities to be detected by an *ordinary safety lamp*." As safety lamps gradually become more *improved*, mines now considered non-gaseous will be subject to classification among the gaseous mines.

SEC. 3. "A second examination by the same or other fire bosses shall be made during working hours of every working place where men are employed." This provision is entirely new and its expense can readily be appreciated.

ARTICLE VI.—SHAFTS, SLOPES, DRIFTS, OPENINGS, AND OUTLETS

SEC. 1. "It shall not be lawful for the operator, superintendent, or mine foreman of any mine to employ *any* person to work therein unless there are at least two openings or outlets * * *. The distance between two shafts shall not be less than *two hundred feet*, * * *, and the distance between drifts shall not be less than *fifty feet*, * * *. And provided further, That the distance specified may be less with the written consent of the inspector." This is slightly modified in Article XXVIII, Sec. 3, of the new law reading: "The provisions of this act shall not apply to any mine employing less than *ten* persons inside the mine in any one period of *24* hours." The old law (Article II, Sec. 2) required a distance of but 150 feet between the two shafts and of only 30 feet between drifts and only (Sec. 1) when more than 20 persons were employed.

SEC. 4. "Every mine generating explosive gas in quantities sufficient to be detected by an approved safety lamp, opened after the passage of this act, shall have at least *four main entries*, two of which shall lead from the main opening and two from the second opening, into the body of the mine: Provided, That every new mine, where locked safety lamps are used exclusively, shall have to open up a large acreage with *main entries five thousand feet or more in length*, shall have at least *five* main entries, two of which shall lead from the main opening and two from the second opening, into the body of the mine, and the fifth (which may be

connected with an opening to the surface or with the intake air-way at or near the main intake opening) shall be used *exclusively as a traveling way for the employes*.

"Every non-gaseous mine opened after the passage of this act shall have at least two main entries, one of which shall lead from the main opening and one from the second opening, into the body of the mine: Provided, That in every new *non-gaseous* mine projected to open up a large acreage with *main entries five thousand feet or more in length*, the operator shall either *haul the employes into and out of the mine at the beginning and end of each shift*, or provide at least *three* main entries, * * *, and one (which may be connected with an opening to the surface or with the intake air-way at or near the main intake opening) shall be used *exclusively as a traveling way for the employes*.

"Should any mine opened as a non-gaseous mine become a gaseous mine, and in every gaseous mine opened prior to the passage of this act, where locked safety lamps are used exclusively, having less than five main entries that have reached five thousand feet or more in length, and *are to be extended two thousand feet or more*, the superintendent shall have a *new opening of ample dimensions made from the surface* if the inspector of the district and two additional inspectors appointed by the Chief of the Department of Mines, shall deem such additional opening necessary, for the proper ventilation of the mines or the safety of the miners. * * *.

"When the *main entry of a non-gaseous mine*, or both *main entries of a gaseous mine*, used for intake for air, are also used for mechanical haulage, a *separate traveling way leading into the body of the mine*, shall be provided for the use of the employes in going to and from their work, or the employes shall be hauled into and out of the mine at the beginning and end of each shift.

"In all mines where the coal seam is *less than three and one-half feet in height*, such traveling way shall be at least *four and one-half feet in height*; in all mines where the coal seam is *four feet in height*, such traveling way shall be at least *five feet in height*, and the width shall not be less than six feet. * * *."

The old law (Article II, Sec. 3) merely provided that "Unless the mine inspector shall deem it impracticable, *all mines shall have at least two entries* or passage ways, * * *." All of the additional requirements for extra entries beyond two, with the alternative of hauling the men to and from work, and the specifications for sizes of traveling ways, are entirely new and will incur very heavy expense, especially in large mines working thin seams. The yardage cost of the additional entries in thin-seam mines will be exceedingly heavy.

SEC. 6. "In mines opened after the passage of this act, if the opening or outlet other than the main opening is a *shaft not more than 100 feet in depth*, and is used by the employes for the purpose of ingress to or egress from the mine, * * *; and shall be fitted with safe and convenient stairways, with steps * * * not to exceed an angle of *forty-five degrees*, * * *." The old law (Article II, Sec. 5) required steps in shafts only when they did not exceed 75 feet in depth and permitted an angle as great as 60 degrees.

SEC. 8. "At any mine where one of the openings hereinbefore required is a slope, and is used as a means of ingress and egress by the employes, and where the angle of descent of said slope *exceeds fifteen degrees*, and its length from the mouth of the opening exceeds one thousand feet, * * *; and at every such mine where the angle of descent of said slope *averages from five to fifteen degrees*, and where its length exceeds three thousand feet, the employes shall be lowered into and hoisted from the mine, at the beginning and end of each shift, at a speed not to exceed six miles per hour: Provided, however, That when a separate traveling way is provided at any such slope, the owner or operator may, at his, their, or its option be exempt from the requirements of this section, if the angle of said traveling way does not exceed *twenty degrees*." Contrast with these requirements the provision in the old law (Article II, Sec. 7) reading: "At any mine, where one of the two openings required hereinbefore is a slope and is used as a traveling way, it shall not have a greater angle of descent than *twenty degrees and may be of any depth*."

A Change House for Coal Miners

Suggested Plans for Construction, and Methods for Keeping the Building in Order

By A. A. Steel*

When miners come from their work tired and sweaty and have to walk a long distance to their homes before changing their clothes, they are liable to contract pneumonia. For this reason, the metal mines of the country are rapidly being equipped with change houses. Although still rare, they are even more necessary at coal mines, because the coal miner cannot so readily carry his overcoat to his working place, and because his pit clothes get so black that he cannot put his street overcoat upon them. To be effective, the change house must be used by the miners. It must, therefore, be large and convenient, well lighted, warmed, and ventilated, and must be kept clean and free from insects.

For the convenience of the miners who come early and wait before going into the mine, a good sized room with benches should be provided. To protect the men from drafts, this room may be placed as an anteroom next to the outer door of the change house. Next to it can be placed the locker room and beyond this the bathroom. A single long building with baths in the middle and lockers and anteroom at each end is the cheapest to construct. Ventilation can then be provided by a large continuous opening along the ridge of the roof, and by open windows just under the eaves and high enough from the floor to insure privacy. These windows also furnish sufficient light for all parts of the building.

Since nearly all the miners must change their clothes at the same time, plenty of floor space is needed in the locker rooms and there is little advantage in making the lockers small or placing them in more than one tier.

To check the spread of insects, partitions between the lockers should be tight and the entire locker room so arranged that, at intervals, it may be tightly closed and filled with some gas poisonous to insects. The building can best be cleaned by washing the entire floor with water from a hose, after each change of clothes. For this purpose, the floor should be cemented and have a slope of about one-fourth inch to the foot toward a drain in the center of the bathroom. The lower part of the walls should be waterproof—cement on brick, or cement on expanded

be sufficient to make the top and bottom of the locker of wire screen and place coils of steam-heated pipe beneath the rows of lockers. With an open ventilator above, the damp air will pass out with but little annoyance from heat or odor. The steam should be turned in for part of each night in all kinds of weather. For heating the building in winter time, there should be wall coils on a separate steam circuit.

Both shower baths and wash basins are needed. There should be ample space in the bathroom for the miners to dry



FIG. 2. CHANGE HOUSE AT UNIVERSAL MINE

themselves before returning to the locker room. It is suggested that a double row of showers be placed over the drain in the center of the room. Along each side, the basins may be placed in wooden sinks beneath a row of faucets. To prevent waste of water, each shower should be provided with a single valve accessible from the outside. The temperature of the water can be adjusted by the attendant. The hot water should be maintained at a constant temperature. It can be kept at the boiling point by coils containing exhaust steam. If the tank is under even a slight pressure, the water will not actually boil and there will be no waste of either steam or water. The hot water should be drawn off from the top of tank and cold water should enter at the bottom. To insure the slight pressure, the tank supplying this cold water can be placed at a slightly higher level. A valve on the connection from each tank to the main supplying the showers is needed, and each tank should have a drain to remove any mud which may settle from the ordinary supply of soft water.

Fig. 1 shows a suggested plan of one-half of such a change house to accommodate 192 men. The lockers are 18 in. x 12 in., outside, and preferably made of metal. The rows are 8 feet apart and there is a bench between each pair of rows. They are arranged for the greatest ease of cleaning the floor, lighting the room, providing access for the miners, and placing the steam coils beneath the lockers. Each locker should be provided with a partition to separate the pit clothes from the street clothes, and should have two narrow shelves near the top, and clothes hooks on all four sides.

For ease of fumigation, the entire building should be tight. If of frame, the cement lining can be carried up to the level of the windows, and the entire outside and roof should be covered with some ready roofing with cemented joints. The partitions between the rooms can also be covered with the roofing, and the ventilator in the roof should be closed by doors operated by ropes from the anteroom.

The only feasible insecticide is carbon disulphide.* This is

*Hydrocyanic acid is cheaper, and in sufficient quantities kills even the eggs of insects. It is, however, such a deadly poison that it can be used safely only by a skilled chemist. Formaldehyde has been recommended but is not effective, costs too much, and leaves a penetrating odor in the clothing.

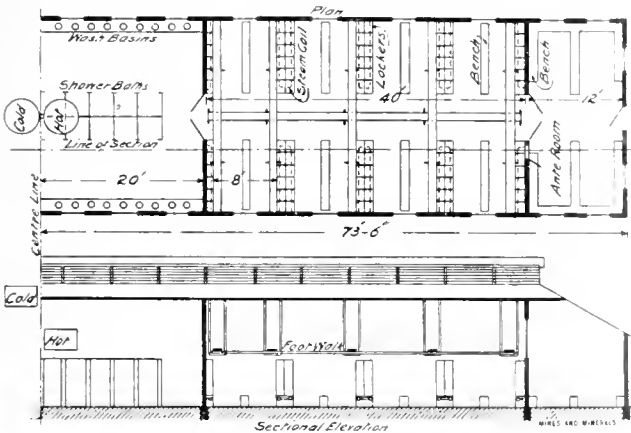

FIG. 1. SUGGESTED PLAN FOR WASH HOUSE

metal lath, if the building is of frame. All the lockers and benches should be supported 15 to 18 inches above the floor by iron pipes or light angle irons.

To effectively dry the miners' towels and pit clothes, a current of warm air must pass through the lockers. Forced circulation may be used, but if the lockers are large, it will generally

* Professor of Mining, University of Arkansas, Fayetteville.

a heavy liquid which boils at 115° F. and rapidly saturates the surrounding air with its vapor. The vapor is nearly three times as heavy as air and fills up the bottom of any enclosed place such as this cement-lined locker room. It can be readily applied by throwing the liquid into the open top of the lockers. For this purpose, there should be plank walks above the lockers, leading to a high door to the anteroom. The attendant will therefore get but little of the vapor. It does not readily affect a human being and causes a warning headache long before there is danger of fainting. It does not injure the hands or delicate fabrics. It has a very disagreeable odor, but this soon leaves clothing hung in the open air. The liquid could be applied after quitting time on a Saturday and all the odor will be gone before Monday if the ventilation is restored on Sunday. Before applying it the steam heat below the lockers should be cut off. The greatest objection to carbon disulphide is its inflammability. The mixture of its vapor and air is explosive and ignites at a low red heat, much more readily than either firedamp or gasoline. All fire must therefore be kept away from it.

Paul Hayhurst, Professor of Entomology, University of Arkansas, states that fleas, lice, and most other insects can be killed by vapor of carbon disulphide if 1 to 1½ pounds of it are applied to each 100 cubic feet of space containing grain, clothing, etc. For open rooms, only one-tenth of this quantity is needed. The locker room sketched here, large enough to accommodate 96 miners, will require only 7 to 10 pounds of carbon disulphide for each fumigation, if the room is filled to a depth of 7 feet. Commercial carbon disulphide can be obtained through a local druggist in lots of 10 gallons or more, at about 10 cents a pound. The cost will therefore be only about 1 cent for each man. It does not kill the eggs, and to prevent all breeding of lice or fleas, the clothing would require fumigation about once every 2 weeks. The few mature insects brought in with the street clothes will not spread seriously. If necessary the locker room could be fumigated occasionally while the men are at work and while the street clothes are in the lockers. It is only for a short season each year and only in warm climates that the fleas are annoying.

The miners are usually willing to pay enough for a good change house to hire the attendant. He should, however, be hired by the mine foreman so that he will not try to coax the men to put up with a little dirt. The operator should furnish hot water and lights and maintain the building. A more pretentious change house at United States Steel Corporation's Universal mine near Clinton, Ind., is shown in Fig. 2. There are no lockers in such change houses, it being more sanitary and probably cheaper to raise the clothes by pulleys. This custom is almost universally practiced in Europe.

采 采

Boiler Ashes for Mine Roads

It may be of interest to the readers of MINES AND MINERALS, who have not used them, to know that boiler ashes, generally considered a nuisance at a mining plant, may be put, at a small cost, to valuable use underground in the dressing or surfacing of haulage entries, partings, and traveling ways.

The Carbon Coal and Coke Co., at their Cokedale plant, Cokedale, Colo., have adopted the use of boiler ashes for their underground haulage and traveling entries.

Ashes on the road have a number of real advantages: They put in good condition wet and muddy sections. They make a firm but porous mixture with fine coal or mine dust and the mixture readily absorbs water and will remain damp for a long time, even in contact with a strong intake ventilating current of dry cold air.

The surface offered by packed ashes, either mixed with fine sand, soft mud rock, or shale, or by itself, is almost ideal for mule haulage and a very perceptible increase in the efficiency of work performed by the mules can be noted.

It also seems to have a stimulating effect upon the men. They enter the mine and travel to their place of work over a uniformly firm, springy, and dampened surface, free from annoying dust, stretches of water, or heavy, sticky, and disagreeable mud, and there is no question but that the mule drivers do their work in a better manner.

This practice may seem a useless expense to many mine managers, superintendents, and underground officials, and such an unimportant matter as to be beneath their notice, but it should be remembered that it is attention to such small details that often represents the difference between success and failure.

As a possible preventative of the spread of explosions along entries, where ashes are properly used, and ribs, timbers, and roof kept cleaned, it may appeal to many.

采 采

Mine Car Door Latch

Two similar mine car end-gate latches which do not jam are shown herewith. The form used at the Cameron mine near Walsenburg, Colo., is shown in the drawing Fig. 1, and Fig. 2 shows the design used at the Heaton mine, Gibson, N. Mex. The former is shown closed or locked and the latter open.

At Cameron the mechanism is mounted on one 9"×12" plate of ¼-inch iron, bolted to the car door through which and the plate

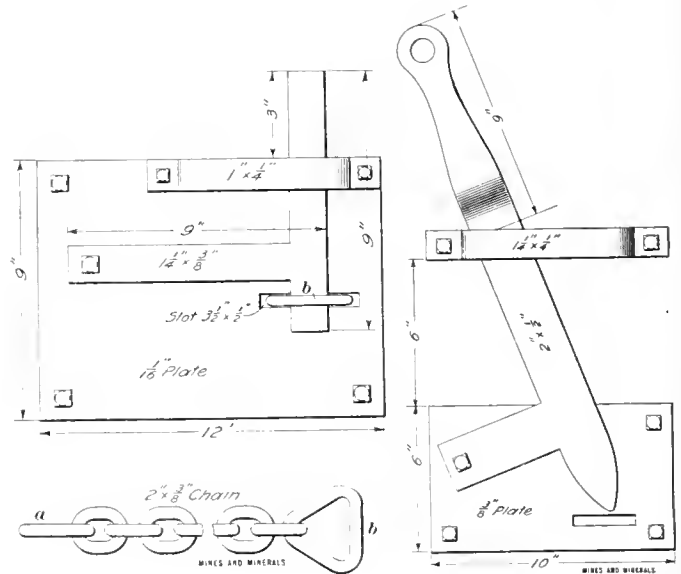

FIG. 1.

FIG. 2.

is cut a slot 3½ in. × ½ in. The two arms of the latch proper, which is made of ¼"×¾" iron, are each 9 inches long, the upper end of the vertical arm projecting 3 inches above the top of the plate to allow of its being pulled back by a hook in the hands of the weigh boss. The chain consists of eight links of ¾-inch iron, each link 2 inches long. Attached to the ends of the chain are two additional triangular links *a* and *b* of the same weight of material, but 3 inches long on each side. The link *b* passes through the slot in the door and plate and is caught by the vertical arm of the latch. The link *a*, by means of a swivel, is bolted to the bottom of the car through the drawbar. When the door is unlatched the chain rests on the floor of the car.

At the Heaton mine, the mechanism is in two pieces, as in Fig. 2, and is made of much heavier material. The lever is longer and is bent outward from the door of the car so that it may be opened by hand as well as by a hook, which latter is the common practice. The lower end of the lever tapers to a point, which does away with the triangular-end link employed at Cameron and permits of the use of an ordinary chain with the end last link somewhat larger than the ordinary.

Progress in Kentucky Geology

Reports on Various Districts Examined and the Work Done. Correlation of Coal Seams

Central City, Madisonville, Calhoun, and Newberg Quadrangles. Field work for reports on these quadrangles, embracing an area of about 800 square miles in the heart of the western coal field, was completed by F. M. Hutchinson in the spring of 1910. This work has revealed a larger number of workable coals in the upper series of beds and larger fields of thick coals than had been known to exist.

Rockcastle County.—The field work for a report on the economic resources and soils of Rockcastle County was completed in 1910, the geology by F. Julius Fohs and the soil investigations by S. C. Jones, with Lucian Walker serving as field aid. It revealed the fact that the coal area of the southern and eastern portions of the county, instead of being practically exhausted, as reported, still contains a large amount of good coal. It was found that the conglomerate sandstone measures, which carry two and sometimes three good coal beds cover 53,700 acres. The average intervals between the beds, as determined by Mr. Fohs, are as follows:

The Corbin conglomerate.....	72 feet
Interval, 91 feet.....	
Corley Hollow coal.....	36 inches
Interval, 144 feet.....	
New Livingston coal.....	8 to 32 inches
Interval, 77 feet.....	
Livingston coal.....	36 inches
Interval, 64 feet.....	
Mississippian limestone and shales.....	Base

The acreage estimated for the respective seams is 40,000 for the Livingston; 28,000 for the New Livingston, and 5,000 for the Corley Hollow, of which not over 1,000 acres have been exhausted, leaving approximately 176,000,000 tons of coal yet to be recovered. Though the seams are, as a rule, thin, it is to be borne in mind that coal beds having no greater thickness are being worked in several other states, that all beds of coal are growing in value, and that these Rockcastle beds have an especial importance in connection with possibilities for the establishment of clay, cement, lime, and other industries that the resources of the country so well justify. The report has been ready since the fall of 1910, but publication was delayed by circumstances that the Director of the Survey could not control.

Pineville Gap Region.—A report which had been prepared by A. R. Crandall and G. M. Sullivan on the Pineville Gap region in Bell and Knox counties, including the Log Mountains, Straight Creek and its branches, Stewarts Branch, and Pourmile Creek in Bell County; and Greasy, Brush, and Stinking creeks in Knox County, was lost by a former contractor for the public printing. It was reproduced by Professor Crandall (requiring some field work in 1910), and has been in the printer's hands since about July 31, 1911.

Hartford Quadrangle.—Geological field work in the Hartford quadrangle (about 238 square miles) was completed in 1910-11, by J. H. Gardner. It is advisable that the report on that quadrangle shall form part of a bulletin embracing at least one other quadrangle. A preliminary report, with special reference to coal, oil, and gas, to serve until the detailed report for the bulletin shall have been completed, has been turned over for publication and there is promise of its appearance by May. While the report is condensed, it has several page maps showing areas of various coals and it will prove useful to prospectors. The work in this quadrangle has shown a larger area of workable coal in the western portion of the quadrangle than has hitherto been definitely known.

Webster County.—Geological field work in the Webster County area—an area typical of disturbed regions within the western coal field—was completed by L. C. Glenn in 1910-11. The report is not quite ready for publication. Because of the increasing interest in this region, concerning which there is little accurate information available in printed form, a brief abstract from those portions

of the report dealing with stratigraphy, structure, and economic resources is given in this report.

Region of the Quicksand Creek.—Field work for a report on the coals of the region drained by the Quicksand Creek, lying in Breathitt and parts of Knott and Floyd counties, was completed by Mr. Fohs in 1911. The report is in the hands of the printer. The region covers an area of approximately 130,000 acres (about 203 square miles) in which occur 11 beds of coal, including cannels. Mr. Fohs reports the net thicknesses of the coals, with the average intervals between beds, as follows:

	Inches
Hindman coal (uppermost bed).....	72
Interval, 60 feet.....	
Flag coal.....	36
Interval, 60 feet.....	
Hazard coal.....	72
Interval, 145 feet.....	
Leatherwood coal. Thin.....	
Interval, 47 feet.....	
Haddix coal.....	36
Interval, 68 feet.....	
Dean (or fireclay) coal.....	36
Interval, 45 feet.....	
Wilson Fork coal.....	36
Interval, 12 feet.....	
Whitesburgh coal.....	30
Interval, 70 feet.....	
Big Branch coal.....	24
Interval, 55 feet.....	
Roundbottom coal.....	24
Interval, 30 feet.....	
Elkhorn coal.....	24

Except on the head of Quicksand Creek, on Middle and Laurel Forks, where the strata dip southeast at the rate of about 16 feet per 1,000 feet, the beds are practically horizontal. The quantity of recoverable coal in the region is estimated as 956,000,000 tons.

Beattyville Coal Area.—A partial examination of the Beattyville coal area was also made by Mr. Fohs. This coal (ranging from 10 to 50 inches in thickness, with an average of 36 inches) underlies more than half of Lee County. The following interesting statement has been presented by Mr. Fohs: "Bells account for the local thinning of the coal, and are of two types: (a) Gondola shaped, 6 to 15 feet wide and 20 feet long; and (b) large, flat boat shaped, up to 100 feet wide and 1,000 feet long. Both types have nearly an east-west strike, so that a north-south cross-cut would usually pass through the thin coal with the least expense. The bed is also subject to rise and fall due to bending of the strata, but this is independent of the thinning of the coal; the small folds appear every 400 to 800 feet and have a general north-northwest trend."

Mapping the Elm Lick Coal.—One of the most important pieces of work undertaken in 1911 was the tracing and mapping of the outcrop of the Elm Lick coal in Ohio and Butler counties, with connections in Daviess. This work owes its importance chiefly to the fact that a key has thus been obtained for the solution of some difficult problems in connection with occurrences of coal in the eastern part and along the eastern margin of the western coal field that for years have given trouble to persons interested in the mining industry. The work was placed in the hands of J. H. Gardner and K. D. White, who were assisted by Lucian Walker. The mapping began at Horton (formerly Elm Lick), in Ohio County. In a brief memorandum concerning the work, Doctor Gardner states: "Our first problem was to trace this coal bed, which had been noted and named by you in an early report, from Horton southeastward toward Butler County. We were able to follow the continuous outcrop of this bed to Morgantown, in Butler County, and to positively connect it with the coal bed which is being mined at Aberdeen. This was a contribution to knowledge and rather surprising in correlation. It affords a key to map the geology of Butler County and adjacent regions on the new topographic sheets which are being prepared in that section of the state. * * * While at Morgantown, we visited the Mud River mine in Muhlenberg County, and were of the opinion that the coal mined there is the same as the Elm Lick, in position." Returning to Horton the party traced and mapped the coal northward until it thinned out north of the Rough Creek Uplift. It had been supposed that the Elm Lick would correlate with the Deanefield coal, but Doctor Gardner reports: "We proved that it is not the same as the Deanefield coal, which extends into Daviess County, but that the latter is the next lower

bed named the Hamlin coal in any section of Ohio County. The Elm Lick coal as traced over the territory outlined is very irregular in character, and will average less than 3 feet in thickness, very rarely approaching 4 feet. It is, however, an important reserve supply in the coal resources of West Kentucky." The mapping was done by Mr. White; the stratigraphy by Doctor Gardner. As the coal was traced southward marked evidences of erosion and unconformity were noted at the horizon of the bed, as had long been known to occur at the horizon of the Aberdeen coal. Mr. White has correlated the Elm Lick with the "No. 5" coal as identified south of Sebree, in Webster County, by Doctor Glenn. If this be correct, it places the Elm Lick coal near the top of the Tradewater formation (a formation unit proposed by Doctor Glenn), where there is also a marked unconformity. The writer understands that from fossil evidence submitted to him, Mr. David White, of the United States Geological Survey, assigns the Elm Lick coal to Pottsville age.

采 采

Practical Coal Haulage

The following paper is one read by A. E. Thompson, Mine Inspector, at the monthly meeting of the employes of the Victor-American Fuel Co.:

Haulage is one of the most important factors in the production of coal; the three systems mostly in use are rope, motor, and mule haulage. Any mechanical system of haulage requires great care in installation if it is to be the system best adapted to the natural conditions of the seam or vein to be operated. But to begin with, power is to be one of the first considerations, whether it be steam, electricity, or compressed air; one should take into consideration the magnitude of the problem to be solved, and install an adequate plant to furnish the necessary power to operate the system of haulage selected.

There should be ample steam power to run the auxiliary machinery necessary for power, such as generators, hoisting engines, and air compressors. The auxiliaries should have capacity enough to furnish sufficient power for all purposes. Should there be a rope haulage installed, it should be properly put in, with the necessary sheaves for carrying the rope and reducing friction to the minimum; on a heavy grade rope haulage is very efficient, but where the grade is variable and roadways are crooked it entails great expense to keep it in repair. Where the grade does not exceed 5 per cent and has an average of about 3 per cent, locomotive haulage seems to be most favored and is more economical; one of the advantages of locomotive haulage is the flexibility of the system, as any number of partings or sidings can be worked, and the closeness of the source of power to point of application makes it desirable.

The tail-rope system is good, and where production can be concentrated to one point, and the grade is so irregular as not to permit a main-rope haulage, or where coal seams are swampy and motors cannot be used to advantage, this is a very desirable system; it keeps the trips stretched at all times and prevents bumping and jerking cars off of the track, thus avoiding the delays of trips being wrecked in this manner over swampy and hilly roadways; under most conditions where there is only one roadway available for haulage purposes, this is the best system to adopt.

Compressed-air locomotives are more desirable than electric locomotives, they being perfectly safe under any conditions, and in mines that generate firedamp there is no danger of their setting off an accumulation of gas that might be driven out on the main haulageways, as there is no trolley that might be knocked down and cause an arc, besides they improve the ventilation of the mine; their size is about the only drawback, and the installation is as cheap or cheaper than electricity.

The next consideration in haulage should be roadways; none of them can be efficient with poor haulage roads; the grade, where possible, should favor the loads, but this will depend

entirely on circumstances. Sometimes it is necessary to pull coal up the hill; the roadbed should be as solid as possible, track well tied and rails heavy enough to withstand the traffic that has to pass over them. Poor roadways are a very expensive luxury, and when the roadways are out of repair delays caused by them greatly increase the operating expenses.

The next essential to haulage and production is management. One may install a system without a flaw, but if it is not properly managed it will not be efficient; management includes everybody connected from the superintendent to the trapper, for mismanagement on the part of any of the operatives along the line is apt to be very disastrous to the entire system.

The superintendent should be a man ever on the alert, observing, and one that is thoroughly familiar with every detail of the system of operation.

The mine foreman should also be familiar with the system so as to direct the operations intelligently and to keep the system efficient. He should have an assistant, a driver boss who thoroughly understands the systems of haulage in use, and has enough executive ability to handle the drivers and trackmen under him. The driver boss should see that the haulage roads are kept in good repair; that the cars and equipment are in good condition; that the cars are properly distributed to the different parts of the operations; see that the cars are evenly distributed among the miners; see that the drivers handle their mules properly, and the necessary harness and repairs are kept where they will be handy should any of them become broken during the day's work. He should also assist the mine foreman in keeping the production on the road, and especially look out for bad-order cars and see that they are shopped and got off the track when they are in bad condition. Often a bad-order car will cause much delay and lose coal, thus increasing the cost of the day's production.

The development work should be kept ahead so that mechanical haulage can be extended in order to reduce animal haulage to the minimum. Any system adopted requires proper installation and management, and without it there can be no real efficiency.

采 采

Atmospheres That Extinguish Flames

At the December meeting of the Coal Mining Institute of America G. A. Burrell, Pittsburg Testing Station Chemist, read a paper from which the following information is abstracted:

To ascertain the percentages of carbon dioxide and oxygen in an atmosphere which failed to support combustion, the different lamps were placed under a 10-liter* bell jar and allowed to remain until their flames were extinguished for lack of oxygen. The atmospheres in the bell jars were then analyzed and the results recorded as follows:

The bonneted Wolf lamp burned until the atmosphere contained 3 per cent. of carbon dioxide and 16.5 per cent. of oxygen. Without the bonnet the same kind of lamp burned until there was 3 per cent. carbon dioxide and 15.82 per cent. oxygen. A candle flame was extinguished when the atmosphere in the bell jar contained 2.95 per cent. in carbon dioxide and 16.24 per cent. in oxygen. An acetylene lamp flame burned until there was 6.30 per cent. carbon dioxide in the atmosphere and 11.7 per cent. of oxygen, or until long after it became dangerous to human life. A natural gas flame issuing from a Bunsen burner went out when the bell jar contained 3.25 per cent. carbon dioxide and 13.9 per cent. oxygen.

Mr. Burrell calls attention to the tenacity of the acetylene flame, which burns in an atmosphere in which the ordinary flames are extinguished, and also says: "It is bad practice to work in atmospheres deficient in oxygen to the extent any of the analyses show."

* 1 liter = 61.022 cubic inches or .2642 gallon.

Air Compressor Explosion

Some Unique Data Upon the Internal Temperatures, Furnished by a Recording Thermometer

By William L. Affelder*

While compressed air at high pressure has proven very satisfactory as a motive power in coal mines in which the use of electricity was not feasible, its use has not been entirely without fatalities. The dangers resulting from personal contact with conductors has, of course, been absent, but the use of compressed air has been attended by fatal accidents due to the disruption of parts of compressors or air lines, especially such parts of lines as were located adjacent to compressors.

This article is not a serious analysis of the theoretical points involved in such explosions, but is intended to display some data upon an actual explosion. While the writer was superintendent of the Redstone plant of the H. C. Frick Coke Co., at Brownfield, Pa., a violent explosion occurred on May 31, 1909, in the 5-inch discharge pipe of a four-stage Laidlaw-Dunn-Gordon air compressor which was producing air at 1,000 pounds pressure for two air locomotives. A hole larger than a man's head was blown in the piping within the compressor room, but fortunately no more serious damage was done than the blowing out of all of the windows of the building. The engineer was working about the compressor at the time, but was not injured.

The compressor was not damaged, and was restarted as soon as a new piece of pipe was put into the line. Several other compressor explosions occurred at about the same time at plants of other companies in the Connellsville region with fatal results.

The fact that the walls of the compressor room were liberally spattered with oil after the explosion, led to the belief that the explosion was, to a considerable extent at least, due to the use of an excessive quantity of oil. An investigation of the question of oil consumption bore out this conclusion, as it showed that the monthly consumption of compressor oil had been 52.2 gallons in 1908 and 12 gallons per month in 1909 up to the time of the explosion. The much smaller quantity in the latter period was due to the fact having been recognized that far too much oil had previously been used, but later observations showed that the reduction had not been sufficient.

While excess of oil in the cylinders and pipes was thought to have been the main cause of the explosion, it was thought that the direct cause of the ignition was the imperfect action of the fourth-stage valves of the compressor. It was not until more than 2 years later that corroborative evidence of a very interesting character was obtainable, perhaps the only positive internal record of the kind in existence.

Shortly after the original explosion, there was installed in the compressor house a Bristol recording thermometer especially designed to record continuously the temperature of the air at the point where it passed from the compressor into the pipe line. By noting the temperature of the discharged air, the engineer was enabled to detect, in a measure at least, any serious defective operation of the compressor valves, for it soon became evident that, under normal conditions, the temperature of the discharged air should not exceed 250° Fahrenheit, although it seldom exceeded 240°.

As a further precaution, a fusible plug was placed in the discharge line near the compressor. This plug was made to blow out at a temperature of between 325° F. and 350° F. It might be added that these plugs, which have been patented jointly by Thomas McCaffrey, general manager of the Brier Hill Coke Co., and C. B. Hodges, of the H. K. Porter Co., are very extensively used, and have in numerous instances given evidences of internal conditions of such a nature that serious results would have occurred had it not been for the warning which they imparted.

As a further precaution against explosions, the use of compressor oil was reduced to only 3.72 gallons per month throughout 1911, as a solution of castile soap and water was used almost exclusively for internal lubrication, with very satisfactory results.

The temperature chart for July 17, 1911, showed that the compressor was acting normally in every way. It showed a maximum temperature of but a trifle over 240° F. at 10:20 A. M., after which it dropped to 220° at noon, and registered 190° and 230° during the remainder of the day. The compressor was shut down at 4:45 P. M., and was restarted at 3:45 the next morning. Between 8 and 9 A. M. the temperature reached 250°, but had dropped to 240° when the chart for July 18 was put on the dial. This chart is reproduced in Fig. 1, and is worthy of very careful study.

It will be seen that by 11 A. M. it was evident that something was wrong with the internal mechanism of the compressor, for the temperature had crossed the 250° mark and continued to rise until it almost reached 270° shortly after 11:15. The engineer

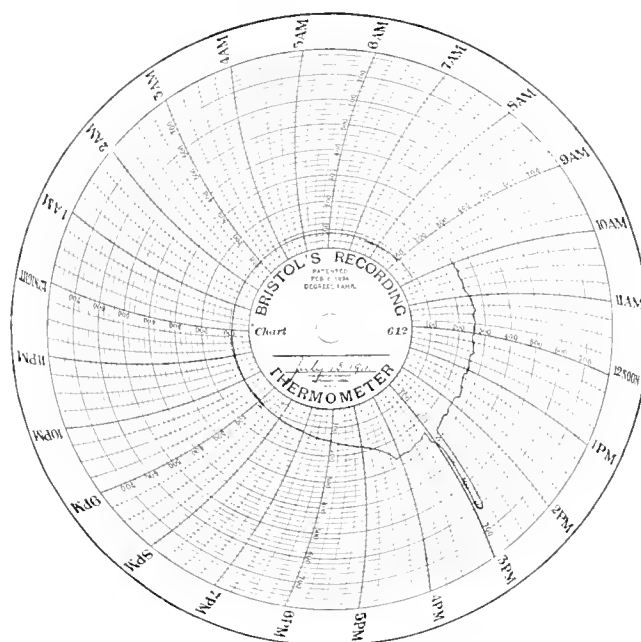

FIG. 1

did not fail to detect the rise in temperature, and upon investigation discovered that the fourth-stage discharge valves were not working satisfactorily, resulting in air working back from the air line into the fourth-stage cylinder. This "churning" of the air was producing heat more rapidly than the cooling water could accommodate. The engineer thought that, by careful running, he could finish the day, as the next day was to be a "lay-off day," and that he could then put in new valves or seats, or both, if necessary. He did not even consider the condition of the compressor as sufficiently serious to report the trouble to the master mechanic. He held the temperature between 250° and about 265° until almost 3 o'clock in the afternoon, when an internal explosion occurred.

The chart shows that this took place at 2:50, at a time when the temperature was slightly above 270°. Coincident with the explosion the fusible plug melted and blew out, releasing the tension and checking the temperature at 620° F. The compressor was immediately shut down and a new plug was put in, taking about 15 minutes, during which interval the temperature dropped to 245°. The engineer then restarted the compressor, in which action he assumed an unnecessary risk, for the temperature again ascended to 270° before it was shut down at 4:10 P. M.

After the defective valves and seats had been replaced with new ones, the compressor was put in operation on the 20th, and the chart for that day showed temperatures between 220° and

*General Manager, Bulger Block Coal Co., Bulger, Pa.

240, but seldom as high as the latter figure, showing conclusively that the explosion was due to the churning of the air and that it was caused by leaking valves. The writer does not doubt that the warning imparted by the chart and the release of pressure afforded by the fusible plug averted a more serious explosion, although the practice of using soap solution and so little oil as was used, would likely have prevented an explosion of great magnitude.

It might be well in concluding to quote the following extract from a description of an air receiver explosion, by Robert E. Newcomb, in *Power*:

"A solution of soft-soap and water is an excellent cleanser for an air cylinder, and may be used without danger; it is even recommended where high-grade oils are used.

"As the washing effect possessed by steam is lacking in air, it will be found that oil remains much longer in an air cylinder than in a steam cylinder; hence a surprisingly small quantity of good oil will lubricate an air cylinder without difficulty. Only the best oils of high flash and fire test should be used. They are the safest and also the most economical in the long run.

"A frequent cause of explosion in compressed-air discharge pipes and receivers is an accumulation of carbon in the pipes or of oil in the receiver. Oil should be drawn off from all air receivers at frequent intervals.

"Another cause of air-compressor explosions is the high temperature caused by the churning or continued recompressing of the air when the discharge valves leak."

來 來

Catalogs Received

S. F. BOWSER & Co., Fort Wayne, Ind., The Bowser Oil Filtration and Circulating Systems, 28 pages.

CHICAGO PNEUMATIC TOOL Co., Chicago, Ill., Folder No. 102, Improved Little Giant Ball-Bearing Drills.

DAVENPORT LOCOMOTIVE WORKS, Davenport, Iowa, Advance Circular of Davenport Locomotives, 72 pages.

DEANE STEAM PUMP Co., 115 Broadway, New York, N. Y., Duplex Horizontal Double-Acting Power Pumps, 44 pages.

THE FURNACE GAS CONSUMER Co., Matteawan, N. Y., Smokeless Chimneys, How to Comply With the Smoke Ordinance, 12 pages.

GOULDS MFG. Co., Seneca Falls, N. Y., Bulletin No. 110, Goulds Single Stage, Double Suction Centrifugal Pumps, 16 pages.

GENERAL ELECTRIC Co., Schenectady, N. Y., Bulletin No. 4942, Thomson Direct-Current Test Meter, Type CB-4, 4 pages; Bulletin No. 4943, Direct-Current Motor Starting Panels for Heavy Service, 4 pages; Bulletin No. 4944, Isolated and Small Plant Alternating Current Switch-Board Panels, 13 pages.

THE HARDY PATENT PICK Co., LTD., Sheffield, England, "Little Hardy" Coal Cutter, "Hardy Puncher" Coal Cutter, "Hardy Simplex" Hammer Drill, 48 pages.

THE HOOVEN, OWENS, RENTSCHLER Co., Hamilton, Ohio, Bulletin No. 115, Series N Hamilton Power Pump, 10 pages; Bulletin No. 117, Series G and H High-Speed Corliss Engine, 16 pages; Bulletin No. 119, Series E Heavy Duty Hamilton Corliss Engine, 14 pages.

INDUSTRIAL INSTRUMENT Co., Foxboro, Mass., Bulletin No. 61, Portable or Hand Tachometers, 8 pages.

INGERSOLL-RAND Co., 11 Broadway, New York, N. Y., Form No. 7004, Cameron Steam Pumps, 12 pages.

HYATT ROLLER BEARING Co., Newark, N. J., Twelve Progressive Mine Car Wheel Makers, 15 pages.

JENKINS BROS., New York, N. Y., Jenkins Bros. Valves, Packing, and Other Mechanical Rubber Goods, 255 pages.

MYERS-WHALEY Co., Knoxville, Tenn., Shoveling Machines for Underground and Surface Work, 20 pages.

NATIONAL ELECTRIC LAMP ASSOCIATION, Cleveland, Ohio, Bulletin 10B, Train Lighting Lamps "Mazda" and Gem, 4 pages.

TOLEDO PIPE THREADING MACHINE Co., Toledo, Ohio, A Pipe-Threading Miracle, 47 pages.*

WIRT ELECTRIC SPECIALTY Co., Germantown, Philadelphia, Pa., The Dim-a-Lite, 16 pages.

UEHLING INSTRUMENT Co., Passaic, N. J., Bulletin No. 100, Second Edition, Combustion and the Cost of Power, 36 pages; Bulletin No. 103, Uehling CO₂ Meters and Waste Meters, 16 pages.

SULLIVAN MACHINERY Co., CHICAGO, ILL., Sullivan Machinery for Contractors. A 16-page booklet reminding contractors of the equipment made for them by the company.

來 來

Obituary

EDGAR J. MEYER

Edgar J. Meyer, Vice-President of the Braden Copper Co., of Chili, was one of those who went down on the "Titanic," as was Colonel George D. Wick, of Youngstown, Ohio, who for a long period was connected with the iron industries of Ohio.

H. FORBES JULIAN

H. Forbes Julian, of Torquay, England, was one of those who went down on the "Titanic." He was a pioneer in the South African gold fields, where in 1887 he was a consulting engineer. He was said to have constructed the first cyanide mill in the Transvaal. In 1888 he erected a better plant at the Roodepoort United Main Reef mill, and successfully treated low-grade ores by the cyanide process, then in its infancy. He was one of the authors of "Cyaniding Gold and Silver Ores," the other being Edgar Smart.

BENJAMIN GUGGENHEIM

Benjamin Guggenheim was another of those who went down with the "Titanic." For a time he was connected with the Guggenheim mining and smelting interests. After the smelting interests were consolidated he retired from active work for a time. In 1903 he entered into the mining machinery business, organizing the Power and Mining Machinery Co., which built large works at Milwaukee. In 1906 this concern was merged with the International Steam Pump Co., and this, his chief business interest, was the reason for his visit to Europe.

ERNST A. SJOSTEDT

Ernst A. Sjostedt, a passenger on the ill-fated "Titanic," was drowned April 14. Mr. Sjostedt was born in Sweden in 1852. He came to America in 1876 and was engaged at the Bethlehem Steel Works, after which he became manager of several iron plants in the United States. In 1898 he went to Sault Ste. Marie, Ontario, where he became the chief metallurgist of the Lake Superior Corporation. He built the reduction works and water gas plant at Sault Ste. Marie, and was recognized as one of the leading metallurgical authorities in Canada. He leaves a wife and one daughter.

MAJOR JACOB ROBERTS

Major Jacob Roberts, for years identified with the anthracite mining industry in various capacities, died at the Wyoming Valley Homeopathic Hospital, in Wilkes-Barre, Pa., on May 6, in his seventy-second year.

Major Roberts was born in Cornwall, England, on December 19, 1840, and came to America with his father when 8 years old. He lived in Tamaqua, Pa., until he was 18 years old, where he attended public and private schools. He then went to Philadelphia to obtain a practical business education. In 1862 he enlisted in Co. E, 129th Regt. Penna. Infantry as a private. For meritorious service in the strenuous campaigns his regiment went through, he was successively promoted through the various ranks from corporal to major. After being honorably discharged at the close of the civil war, he returned to Tamaqua and entered

on the business of mining with his father at Newkirk and later at Mahanoy City. In 1868 he and his father went to Plymouth, Luzerne County, Pa., and opened an operation known as the Union mines. Later he was one of a company, and its president, which opened the Fairmount colliery near Pittston, Pa. Several years later Major Roberts with M. L. Dreisbach organized the Hanover Coal Co. and conducted very successful operations at Sugar Notch, Pa. After disposing of his interests in the Hanover Coal Co. he entered the political field and was elected to the State Legislature in 1897. After the expiration of his term of office, he was connected with the Wilkes-Barre Knitting Mills Co., and was its treasurer and general manager. In February, 1905, he resigned this position and opened offices in Wilkes-Barre as a coal specialist, and in this capacity he examined and reported on mineral properties in various parts of the country. In addition to his other business, he was interested in and a director of the Flat Branch Coal and Coke Co., of Tracy City, Tenn. He was also interested in mining operations in Virginia, and was a director of the Wilkes-Barre Deposit and Savings Bank.

Major Roberts was a member of various Masonic bodies, and was a charter member of Dieu Le Vient Commandery, Knights Templar, of Wilkes-Barre. He was also affiliated with the Odd Fellows, and Knights of Pythias, and a member of the G. A. R.

Major Roberts was married on September 16, 1863, at Mauch Chunk, Pa., to Miss Emma A. Simpson. His widow, one son, William, and an adopted daughter survive him.

HORACE J. STEVENS

Horace J. Stevens died April 22, 1912, when going to his office in Houghton, Mich. Mr. Stevens was born January 19, 1866, at Cattaraugus, N. Y., where he resided until 18 years of age, when he left for Ishpeming, Mich. Mr. Stevens worked for 5 years about the Beaufort mine and thus secured information which enabled him in later years to compile the reliable statistics for "Stevens' Copper Handbook," and to assume the duties of the copper department of the *Mining Journal*, of Ishpeming. He leaves a wife, daughter, and son, the latter a student in the Michigan School of Mines.



Combatting Miners' Diseases

An arrangement has been made with the Public Health and Marine Hospital Service by which one or more surgeons connected with that service will carry on jointly for that service and for the Bureau of Mines investigations looking to the improvement of mine conditions. These inquiries and investigations have already shown the prevalence of tuberculosis and hookworm as miners' diseases in a number of different localities in the United States. It is important that this work should be extended more rapidly, because of the fact that the health conditions, as well as the risk of accidents, may be influenced by conditions susceptible of easy improvement. Furthermore, the large and continuous influx of foreigners into the mining regions of the United States will bring to an increasing extent the hookworm and other diseases that abound in mines in parts of certain European countries.

Various questions that concern the health of workers in mines, quarries, and metallurgical plants can not be answered finally without investigations and inquiries that are national in scope. Among such questions are the most efficient methods of preventing the diseases peculiar to certain industries, the most effective sanitary precautions to be observed in and about coal mines and metal mines, and the relative healthfulness of occupations pertaining to mining and metallurgical industries. The investigations and inquiries that are essential to the gathering of reliable information on these questions can be undertaken by the Bureau of Mines, in connection with its collection of accident statistics, in a prompt and efficient manner and at minimum expense.

Rockvale New Air Slope

A new air slope to the Rockvale mine of the Colorado Fuel and Iron Co., at Rockvale, Fremont County, Colo., has just been completed under the supervision of Harry John, superintendent; W. K. Jones, assistant mine foreman; and J. Q. McNatt, civil engineer. The work was begun by the C. F. & I. Co. upon the inside, working upward at an angle of 22 degrees, or 40-per-cent. grade, and the contractors beginning upon the outside driving downward toward the company men.

This was a difficult piece of work, as there was but one opening into the mine through which a survey could be made and this was the hoisting shaft No. 1, which is 323 feet deep and too small to be of use as far as dropping two points for a base line. So by using a survey that was run underground from this No. 1 shaft to the No. 4 shaft, 1,500 feet distant, the latitude and departure of each shaft center was calculated from the coordinates of the outside base-line points.

From the outside base line a survey was run to find the latitude and departure of the lost station 0 or center of the shaft No. 1, then by dropping a plumb line station 0 was restored at the shaft bottom. Station 3 underground was found intact, and from the latitude and departure of stations 0 and 3 their bearing was calculated, and the stations used as a new underground base line.

From these base lines surveys were run to opposite ends of the proposed tunnel, from which sights were set for the contractor's guidance.

All distances between stations were measured in part, then total measurements made to avoid any chance of miscalling the

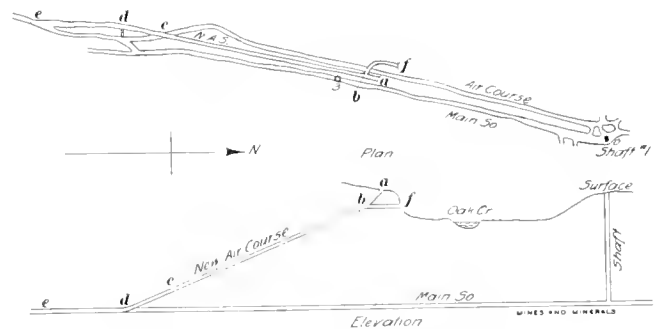

FIG. 1. PLAN AND ELEVATION OF AIR SLOPE

figures on the chain. Vertical angles were read both forward and backward at each station and the difference in elevation between stations was calculated from the vertical angles and measurements, and checked by the level and rod.

The mouth of the tunnel is 500 feet south of shaft No. 1 and 7 ft. x 9 ft. in section. The contractors drove 725 feet from the outside, the first 42.6 feet on a 45-degree pitch, the balance on a 22-degree pitch to the place of connecting; they also made the man-way *bf* from the top end of the 22-degree pitch on a level grade to the outside. The C. F. & I. Co. men drove *ed* 204 feet at a slight grade to intersect with the 22-degree slope; then followed the *dc* slope to the place of meeting.

In this new slope the workmen encountered various formations: slate, shale, coal, and sandstone. The part through the sandstone strata will need no timbering, but the looser formations will be reinforced with concrete supports, and a concrete stairway will be built the entire length of the 22-degree pitch.

The slope is being well drained and will be electric lighted and used as a traveling road; it will supply abundance of air to the miners as well as an excellent outlet for men and mules. A large fan and fan house will be built at the mouth of the slope and a concrete stable at the lower end to accommodate some 50 mules.

The C. F. & I. Co. has recently completed a tunnel connecting Rockvale mine with the Coal Creek mine, this making three available exits in case of fire or accident of any kind.

Lookout Mountain Coal Measures

Geological Formation—Thickness—Quality of the Coal as Shown by Analyses—Costs of Mining

By A. W. Evans*

The structure of Lookout Mountain consists of horizontal beds of limestone, sandstones, and shales formed during the Carboniferous period. These strata have undergone great lateral pressure and thrust that formed a huge synclinal fold with its axis ranging northwest and southeast. The northern end of the fold is at Chattanooga, Tenn. (see Fig. 2) while its southern terminus is at Gadsden, Ala., 90 miles distant. Broadly speaking this synclinal trough is symmetrical, that is the rocks dip gradually from the brow of the hills toward the center of the basin. As features common to most coal fields, there are faults, folds, and irregularities in the rocks, which have direct bearing on the commercial value of the coal. Most of the coal measures, above the upper conglomerate have been eroded, leaving one remnant, however, known as Round Mountain, on top of the plateau, near its northern end. Two seams of commercial value in the upper coal measures are found in this mountain, namely, the Durham and Tatum coals. The rock series forming Lookout Mountain consist of the Bangor limestone, and the Lookout and Walden sandstones. The Bangor limestone has its greatest development near the Georgia-Ten-

nessee line where it reaches a thickness of 700 feet, and gradually decreases to the southeast to a thickness of approximately 400 feet. It is a difficult matter to definitely determine its correct thickness, as it gradually merges into calcareous shales above and below into the Fort Payne chert. The Bangor limestone is coextensive with the mountain and can be seen outcropping along its base on each side in long narrow strips. The economic value attached to the limestone comes mainly from its adaptability to building, to fluxing material, and to the manufacture of lime. As a flux for iron smelting it is all that could be desired, being high in lime, and low in silica, magnesia, and impurities. The sample from a quarry at Battelle, Ala., gave the following analysis:

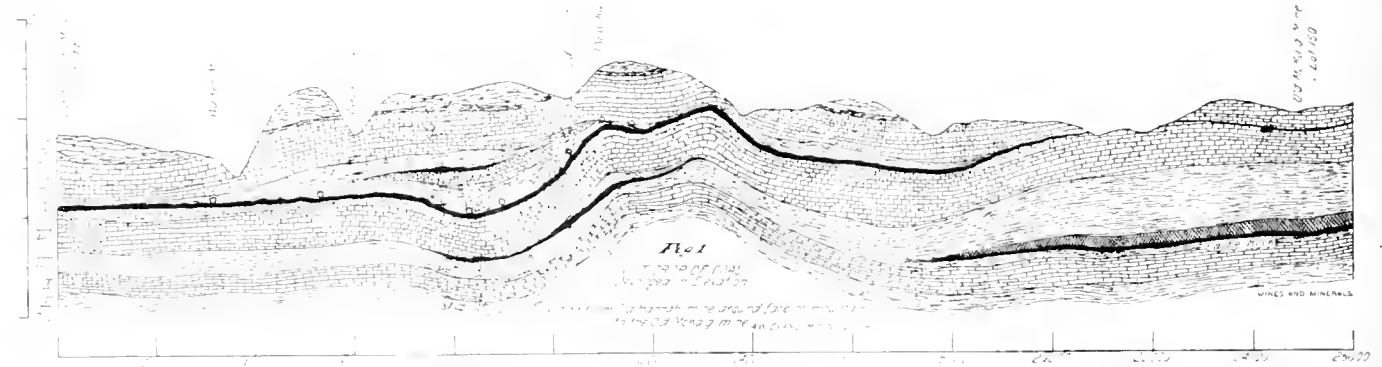

FIG. 1

nessee line where it reaches a thickness of 700 feet, and gradually decreases to the southeast to a thickness of approximately 400 feet. It is a difficult matter to definitely determine its correct thickness, as it gradually merges into calcareous shales above and below into the Fort Payne chert. The Bangor limestone is coextensive with the mountain and can be seen outcropping along its base on each side in long narrow strips. The economic value attached to the limestone comes mainly from its adaptability to building, to fluxing material, and to the manufacture of lime. As a flux for iron smelting it is all that could be desired, being high in lime, and low in silica, magnesia, and impurities. The sample from a quarry at Battelle, Ala., gave the following analysis:

Silica, 1.82; magnesium carbonate, Mg_2CO_3 , .90; alumina, etc., R_2O_3 , 1.16; calcium carbonate, $CaCO_3$, 95.40

The Lookout Mountain sandstone series or the lower coal measures, consist mainly of conglomerates, shales, and thin seams of coal. The thickness is quite variable, ranging from 250 feet to 400 feet. The upper part forms the main rim rock of the mountain and presents a striking topographical feature. The Walden sandstone series occupies a position immediately above the upper Lookout series and forms the cap rock of the mountain. The series consist of sandstones, shales, and conglomerates, and from two to seven seams of coal. In the Round Mountain district its thickness is given by the United States Geological survey as 930 feet.

*Superintendent, Brushy Mountain Mines.

was circumscribed with drill holes, and the coal was found to be extremely thin.

The Rattlesnake coal can be found easily unless the alluvial soil has covered the outcrop completely; for it is between the upper and lower conglomerates. It is found at various points along the eastern and western escarpment of the mountain and has been mined for years at Rising Fawn, Ga.; Battelle, Ala.; Lahausage, Ala.; Beesons Gap, near Fort Payne, Ala.; and in the point of the mountain near Gadsden, Ala. Due to irregularity in the coal bed and not to changes in surface features, variation in thickness of the coal seam is found that no doubt represents the individual marshes of the period of deposition. J. W. Spencer, formerly State Geologist of Georgia, in his Paleozoic Group says: "Many of the deposits although separate had doubtless a synchronous origin." The mining operation at Rising Fawn, Ga., commenced on the Rattlesnake in the early 70's and is about a half-mile due east of the McKaig mine. The prospect was not a favorable one and work was abandoned. Dr. George Little, formerly State Geologist of Georgia, in speaking of this operation in 1876 said: "On the Dade side of the mountain the coal has been opened near the summit of the cliff in Johnsons gulf, in a vein 4 or 5 feet thick and an incline built by which the coal is brought down to the foot and thence by narrow-gauge railroad carried 4 miles to Rising Fawn furnace, where 60 Belgian coke ovens have been constructed for supplying fuel for their 50-foot stack." The Rattlesnake coal on this property has the following analyses:

Fixed Carbon	Volatile Matter	Ash	Sulphur	Phosphorus
76.59	20.01	2.96	1.09	
76.50	19.58	3.92		
75.08	17.24	7.68	1.27	.006

The operation at Battelle, Ala., commenced mining the Rattlesnake coal in 1892, although known locally as Eureka coal. The Dade seam outcrops immediately above the Rattlesnake and is

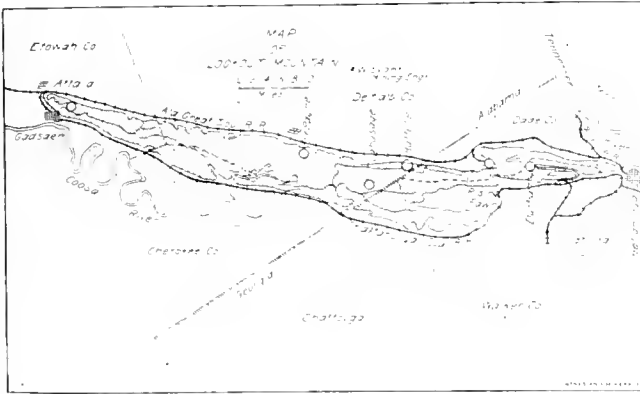

FIG. 2

known as the Sewell seam. The Lookout Mountain Iron Co., whose operations were at Battelle, drove three slopes on the seam in an easterly direction. The shale roof was tender and gave trouble from the start. Measurements of the coal at slopes "C," "D," and "E" gives the following sections: 38 inches, 39 inches, 36 inches; there is about 20 feet of shale between the conglomerate and the coal; two partings occur in the coal, one about 6 inches from the top that will average 2 inches in thickness, the other about 12 inches from the bottom that will average about 1½ inches in thickness.

The coal at this point is closely associated with the conglomerate, and thins down going toward the basin of the mountain. The two coal seams at this point have an elevation above sea level of 1,650 and 1,720 feet, respectively. Chemical analyses of these coals are as follows:

Fixed Carbon	Volatile Matter	Ash	Sulphur	Moisture	Phosphorus	SiO ₂
71.90	19.80	7.65	1.25	.65	.0085	3.82
74.20	16.70	8.35	1.07	.75	.0210	

Approximately 10 miles of outcrop coal occurs on this property, and with scientific management, concentration of all productive factors, rigorous supervision of the working forces coupled with a thorough knowledge of the environments, the coal costs at the tipple from \$1.30 to \$1.50 per ton. At this plant twin Robinson washers were installed to wash coal for coke making. The analysis of the coke follows:

Moisture	Fixed Carbon	Volatile Matter	Ash	Sulphur
.55	79.20	2.50	18.50	1.77
	9.35	.95	19.15	1.86

The cost of mining per ton at the Battelle is as follows:

Mining.....	.623
Bank work.....	.983
Dead work.....	.147
Timbering.....	.111
Hauling.....	.152
Pumping.....	.037
General expense.....	.003
Operating incline.....	.018
Operating tipple.....	.015
Smithing.....	.018
Engineering.....	.036
Power.....	.090

\$1.333

Further south, but adjoining, the Lookout Fuel Co. owns about 12,000 acres of land in the center of the mountain that is drained by the Little River and its tributaries. Mining operations commenced here in 1904, transportation facilities being furnished by the Chattanooga Southern Railroad. The Rattlesnake seam on this property averages about 20 inches in thickness and is not uniformly in position but dips at all angles. At approximately 2,000 feet from the outcrop in a northerly direction the coal squeezes out. At some points the two conglomerates come together and the coal is only a pencil mark. The mine was opened in the only logical point, on a gentle anticline, where the coal has a shale roof and was above the bed of Brushy Creek. The cost of mining at this point was \$1.35 to \$1.56 per ton. For a close approximation of the cost of mining coal on Lookout Mountain the reader is referred to the chart shown in Fig. 3. An analysis of the coal at Lahausage on the property of the Lookout Fuel Co. is as follows: Moisture, .38; volatile matter, 20.07; fixed carbon, 76.72; ash, 2.83; sulphur, .92. The calorific value is 15,516 British thermal units, specific gravity, 1.30. A car lot sampled by the United States Geological survey at their testing plant in St. Louis gave the following analyses: Moisture, 3.35; volatile matter, 16.50; fixed carbon, 66.07; ash, 14.04; sulphur, 1.29. The following is an analysis of the coke: Moisture, .45; volatile matter, .35; fixed carbon, 81.69; ash, 17.51; sulphur, 1.

The ovens yielded 66.50 per cent. coke from this coal that had a compressive strength of 297 pounds per cubic inch and was capable of supporting a furnace charge of 115 feet. Going south along the mountain from this point the coal is mined at Beesons Gap, near Fort Payne, Ala. Here the coal is thin and cost of mining excessive. The operations named cover those in the lower formation, and from a commercial standpoint they were not successful. The upper coal measures are fully represented in Round Mountain, where two workable seams of coal are found called the Durham and the Tatum. The Durham is the uppermost in the series and has an elevation of 1,824 feet above mean tide. There are approximately 1,738 acres of land having these upper coal beds. Shipments from the Durham mine commenced in 1892, and the mine has continued to be a large producer. Shipping facilities are furnished by the Central of Georgia Railroad. The average thickness of the Durham coal is about 42 inches with a parting from 4 inches to 12 inches. About 165 feet below this seam is found the Tatum coal, a thin seam that can be worked in places. The interval between the seams shows the following section in a descending order:

Durham seam.....	42 inches
Fireclay.....	2 feet
Sandstone.....	80 feet
Black and gray shale.....	50 feet
Massive sandstone.....	18 feet
Black shale.....	15 feet
Coal.....	26 inches

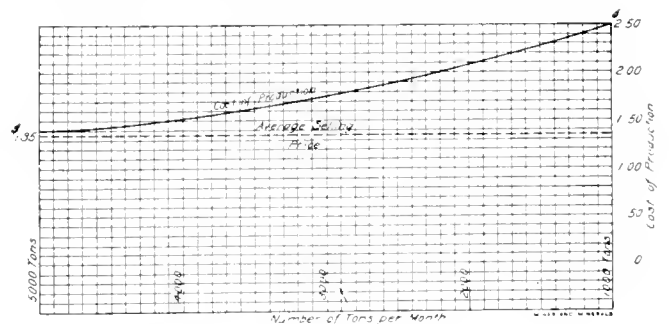

FIG. 3

An analysis of the Durham coal gives the following composition:

Fixed Carbon	Volatile Matter	Moisture	Ash	Sulphur	Phosphorus
79.10	16.03	.615	4.81	.36	.007
75.95	21.01		1.94	.47	

The analysis of the coke is as follows: Fixed carbon, 90.31; volatile matter, 1.205; moisture, 0; ash, 8.53; sulphur, .53; phosphorus, 0.

The Tatum coal gives the following analysis: Fixed carbon, 75.98; volatile matter, 20.850; moisture, 1.02; ash, 1.410; sulphur, .76; phosphorus, .007.

It will be observed that the two coals are similar and ideal for steaming and coking purposes. The coals of the Lookout Mountain are similar in structure, all of them friable and breaking with a columnar structure. The coke from the Durham seam has a higher percentage of fixed carbon than the Pocahontas and its ash and sulphur content is unusually low.

Personal

Claude Easley is superintendent for the Guadalupe mine, Inde, Durango, Mex.

A. D. Cox is engineer for the Tonopah-Belmont Mining Co., of Goldfield, Nev.

C. R. Downs is superintendent of the Keystone mine at Amador City, Cal.

E. L. Haff is superintendent of the Amalgamated Nevada mine near Ely, Nev.

B. B. Lawrence is consulting engineer for the Horn Silver Mining Co., Frisco, Utah.

S. R. Gayton is managing the operations of the Crooked Creek placers at Dixie, Idaho.

A. A. Marshall is superintendent of the Yerington Copper Mining Co. at Yerington, Nev.

J. K. Turner, of Goldfield, Nev., is reopening the Panamint mine west of Death Valley, Cal.

John C. Greenway is general manager of the Calumet and Arizona Mining Co., Warren, Ariz.

John F. Shelly is president and manager of the Utah-Arizona Gold and Copper Mining Co.

A. M. Harris has recently become superintendent for the Marysville Gold Dredge Co., Marigold, Cal.

A. W. Newbery is assistant general superintendent for the Mammoth Mountain Mining Co., Isabella, Cal.

Col. G. G. Vivian is now manager of the Pittsmt smeltery of the East Butte Copper Mining Co., Butte, Mont.

G. M. Butler, assistant professor of geology, Golden, Colo., recently inspected mining property east of Salt Lake City.

S. W. Laughlin is assistant engineer with the Butte and Montana Consolidated Copper and Silver Mining Co., Butte, Mont.

A. H. Storrs, of Scranton, Pa., has been elected president of the Jed Coal and Coke Co., of Jed, W. Va., as successor of W. A. Lathrop, deceased.

Edward H. Cox, general superintendent of the coal mining department of the Tennessee Coal and Iron Co., has resigned his position with that company.

James R. Finlay addressed the students of the class of 1912 Missouri School of Mines on commencement day. The graduating class this year numbers 40.

W. L. Saunders, President of the Ingersoll-Rand Co., New York, N. Y., delivered the commencement address at the Colorado School of Mines on May 24.

C. M. Kornuff, who has been superintendent of the Jed Coal and Coke Co., has been appointed manager of that company, a merited recognition of past services.

F. V. Bodfish, formerly operating mines in the Cripple Creek and Park City districts, is now developing the Legitimate and the Guarantee mining properties at Jarbidge, Nev.

J. B. Tyrell, the well-known geologist and explorer, of Toronto, Can., will lead the Ontario Government expedition into the north country and explore parts of Hudson Bay.

William C. J. Rambo, recently superintendent for The Grand River Coal and Coke Co., of Gainesville, Mo., and L. G. E. Bignell, have formed an incorporated partnership to be known as

The Rambo-Bignell Engineering Co., and will engage in mining and metallurgical engineering, with offices in the First National Bank Building, Denver.

E. E. Shumway, president of the Rocky Mountain Fuel Co., gave a very interesting address before the Colorado Electric Club, April 4, on "Electrical Appliances in Coal Mining."

W. P. J. Dinsmoor, for several years manager of the Sullivan Machinery Co.'s office at Denver, Colo., has been appointed manager of the Chicago sales office of the same company.

Walter R. Ingalls, editor of the *Engineering and Mining Journal*, on April 19 delivered the class day address to the graduates of 1912, Michigan College of Mines, Houghton, Mich.

Cyril Brackenbury, of Benwell, Newcastle-on-Tyne, whose paper on "Unwatering Tresavean Mine" recently appeared in *MINES AND MINERALS*, is at present in Greece on professional business.

V. G. Hills returned to Denver in April after spending over a year in Halifax County, Nova Scotia, where he built a 25-ton mill to treat tungsten ore from the property of the Scheelite Mines, Ltd.

William Kelly, general manager of the Penn Mining Co., Vulcan, Mich., and one of the trustees of the Michigan College of Mines, delivered an address, on April 19, to the 1912 class of that institution.

Louis D. Huntoon, B. Stoughton, and A. H. Elliott have become associated in the general practice of mining, metallurgical, and chemical engineering, with offices at 165 Broadway, New York City.

George W. Blackinton, for several years employed in the general offices of the Sullivan Machinery Co., in Chicago, has been appointed general sales manager of the Denver, Colo., office of the company.

C. P. Collins, civil and mining engineer, of Johnstown, Pa., on May 1, became associated with the Berwind-White Coal Mining Co., as engineer. Mr. S. E. Dickey succeeds to the business in Johnstown.

The firm of Weed & Probert has been dissolved by mutual consent. Mr. Frank H. Probert will continue to practice as consulting engineer and mining geologist, with headquarters at 314 Central Bldg., Los Angeles, Cal.

William Leckie has resigned as manager of the Jed Coal and Coke Co. in order that he can devote more of his time to other operations in which he is interested. Mr. Leckie has recently started a coal operation on Tug River.

F. C. Carstarphen is consulting engineer for the Gilsonite Co., which maintains offices in Denver, New York, and Myton, Utah. He is local manager for the company at Myton, where are located the company's mines which produce gilsonite.

George Watkin Evans, of Seattle, Wash., has opened an office as consulting mining geologist and engineer, specializing in coal. Mr. Evans recently resigned from the position as Chief of Coal Surveys of the Washington Geological Survey, and has opened an office at 427 Leary Bldg., Seattle, Wash.

Prof. G. M. Butler, of the Colorado School of Mines, addressed the Colorado Scientific Society, April 6, upon the manufacture of artificial gem stones. The lecture was made interesting by the exhibition of numerous examples of these gems, which are in every respect the equal of the native stones.

A. B. Jessup has resigned as chief mining engineer of the Lehigh Valley Coal Co. to accept the position of general manager of the G. B. Markle & Co. collieries at Jeddo, Pa. Mr. Jessup entered the service of the Lehigh Valley Coal Co. immediately after graduating from Lehigh University about 15 years ago, and through work and ability won successive promotions until he reached the position he has just resigned. On the evening of May 4 he was tendered a farewell dinner at the Hotel Sterling, Wilkes-Barre, Pa., by the operating officials of the Lehigh Valley Coal Co., and was presented with a valuable gold watch and fob as a mark of esteem from his late coworkers.

Electricity in the D. L. & W. Mines

Applications of Electric Power by the D. L. & W. Co. to Hoisting, Pumping, Haulage, and Lighting

The electrification of the collieries of the Delaware, Lackawanna & Western Railroad Co. is unusually extensive, and the central stations and the distribution systems are excellent examples of modern engineering. About 20 collieries are in operation at the present time, all of them being situated in Lackawanna and Luzerne counties in the northern anthracite field of Pennsylvania, their output for the year 1910 being approximately 8,000,000 tons.

The bulk of the mining is done by means of shafts, although there is considerable slope and drift mining and a number of washeries. All the collieries, with two exceptions, utilize elec-

converters installed is 26, and their rated capacity 6,650 kilowatts. Mine locomotives are very extensively used, there being 170 now in service; 125 of these are 6½-ton cable reel, and 45 are 10-ton straight haulage units with a total motor capacity of 10,750 horsepower. A large proportion of these are 250-volt units, and current is normally supplied at 275 volts in order to take care of the line drop involved by the length of the feeders. In one mine there are 550-volt locomotives, and in five of the mines direct current for haulage is supplied through a three-wire system at 275-550 volts. Five of the collieries have direct-current engine-driven sets arranged to operate in parallel with the rotary converters, and in this way reduce the investment cost of the current-distribution system.

The distance covered by the feeder systems for the locomotives exceeds 148 miles, while the transmission distances from the turbogenerator stations total about 35 miles.

One of the most important applications of electricity in these



TRUESDALE BREAKER

tricity for both light and power, and these two have small isolated generating plants for lighting.

Most of the mines have had electric service for a number of years, and the original equipment included direct-current engine-driven generators, some of which are still in operation, while the others are now held merely as reserves. The main source of electric supply at present consists of two central stations, equipped with steam turbine-driven generators; the Hampton station serves the upper district in the vicinity of Scranton, Pa., while the second supplies the lower district around Nanticoke, Pa.

At the Hampton station current is generated at 2,300 volts, three phase, 60 cycles, while the Nanticoke alternators are 4,150-volt units. Three potentials are used in transmission, 2,300, 4,150, and 16,000 volts. The capacity of the Hampton station is 6,500 kilowatts, that of the Nanticoke power plant is 2,500 kilowatts, and, in addition to these, there are engine-driven sets having a rated output of 2,390 kilowatts, so that the aggregate available generator capacity is 11,390 kilowatts.

There are 21 sub-stations located in the various collieries, all utilizing rotary converters. A few of the more distant collieries are not supplied with rotary converter substations and still operate the original engine-driven sets, while in other cases these sets are retained only as reserves. The total number of rotary

mines, aside from that of mine haulage by means of locomotives, is found in the use of electrically-driven hoists for which both alternating- and direct-current motors are used. There are 27 of the alternating-current type having a total capacity of 3,570 horsepower, and 25 operated by direct-current motors, taking 2,420 horsepower, or an aggregate of about 6,000 horsepower, required for this one service.

The notable improvements in the design of centrifugal pumps during the last few years has resulted in numerous installations in the mines of this company, both for auxiliary pumps and for operation at the main sumps. As in the case of the hoists, both alternating- and direct-current motors are used, although, due to the conditions which control the induction motor, all of the newer stationary pumping sets are driven by alternating-current motors which, with their high efficiency at constant speed and uniform load, are peculiarly adapted for the operation of centrifugal pumps.

There are 46 alternating-current motors, aggregating 5,670 horsepower, utilized in this service, and 48 direct-current motors with a total capacity of 1,400 horsepower, used for driving both centrifugal and plunger pumps. Most of the direct-current sets are small auxiliary units, and a number of them drive 300-foot head, portable, plunger power pumps mounted on trucks, which

can be hauled to various locations in the mines and operated from the locomotive feeder wires.

In addition to the motor-driven water-bucket hoisting equipment, the sump at Hampton is served by two six-stage centrifugal pumps operating at 720 revolutions per minute against a 500-foot head; each pump delivers 5,000 gallons per minute and is direct driven by a 1,000-horsepower, 2,300-volt induction motor. Inasmuch as these two centrifugal pumps and the water hoist represent a total demand of 2,800 horsepower, they constitute a most important factor in determining the peak load of the Hampton generating station, and for this reason they are normally operated at night, the sump being of sufficient size to take care of ordinary drainage during the day time. As the demand on the power station diminishes toward the end of the working day, the load on the generators is brought up to approximately normal



HAMPTON WATER HOIST

level by successively throwing into service the two centrifugal pumps and the water-hoisting outfit.

The water which is elevated from the Hampton sump is utilized in various ways before it is discarded. It first passes to a reservoir where it is used for the operation of barometric condensers, as the steam turbines operate condensing, and from the condensers it passes to a washery, being thereafter used for silting ashes, crushed rock, and other mine refuse into worked-out sections of the mines through bore holes.

In addition to those enumerated, there are 127 alternating-current motors, aggregating 530 horsepower in capacity, and twelve direct-current motors, totaling 225 horsepower, which are used for auxiliary service in the mines and collieries. Fifteen of these are utilized to drive rock crushers through belting, and a number are belt connected to fans, although most of the ventilation in these mines is still furnished by engine-driven fans.

An interesting application of individual motor drive is found in three of the breakers operated by this company, which are equipped with induction motors, direct connected to various driving shafts, thereby minimizing the number of belts required, and reducing the friction losses inseparable from the operation of breakers by steam engines. Separate motors are provided for running the trips up the incline to the top of the breaker, so that the delivery of coal to the dumping chutes may be continued when the balance of the machinery is shut down.

Individual drive for these breakers was adopted about 7 years ago, and the efficiency obtained is indicated by the records of the

Truesdale breaker, which handles between 3,500 and 4,000 tons of coal per day with a power consumption of approximately 1 kilowatt-hour per ton of coal, including the hoisting of the coal to the top of the breaker.

The extent to which electric drive has been adopted in these collieries is shown by the following aggregate motor capacities:

	<i>Horsepower</i>
Direct-current locomotives.....	10,750
Alternating-current hoists.....	3,571
Direct-current hoists.....	2,420
Alternating-current pumps.....	5,670
Direct-current pumps.....	1,402
Alternating-current, miscellaneous.....	3,580
Direct current, miscellaneous.....	225
Total, alternating current.....	12,821
Total, direct current.....	14,797

Grand total..... 27,618

The equipment of the Truesdale colliery will serve as a typical example of the substation practice of the Delaware, Lackawanna & Western Railroad Co.

Power is transmitted at the generator voltage from the Nanticoke station and received at a transformer substation located at the colliery. The substation equipment includes step-down transformers and two six-phase rotary converters, one of 200-kilowatt and one of 500-kilowatt capacity. The current, which is received at 4,150 volts and is stepped down in the transformers to about 200 volts, is for the operation of the rotary converters, and separate transformers supply 440-volt circuits for the induction motors. Steam is still used at Truesdale for hoisting in the shafts, operating ventilating fans, and heating the breaker, but all other operations are carried on electrically. The total current consumption averages 12,000 kilowatt-hours per day, about one-third of this being required for the breaker.

The local current distribution and control are provided for by means of a switchboard containing a totalizing panel, and feeder panels for the various alternating- and direct-current circuits.

There are 16 locomotives, having a total capacity of 1,150 horsepower, but, as they constitute an intermittent demand, the 500-kilowatt rotary converter is of ample capacity for their operation, and in addition it serves five motors with a total rated capacity of 937 horsepower, driving car hoists on slopes. When the day load diminishes, the direct-current equipment is switched over to the 200-kilowatt rotary converter, which was originally of ample capacity to carry the entire load, but is now normally held for night operation or emergency service.

Of the 13 pumps at this colliery, which have a total capacity of 610 horsepower, all but one are located in the mines. The track, or portable, pumps are driven by direct-current motors, while all stationary units are of the induction-motor-driven centrifugal type.

Three 250 kva. 4,150-440 volt transformers are provided for the alternating current circuits on which 30 motors, with a total capacity of 700 horsepower, are operated. Most of these are utilized for individual drive in the breaker and the remainder operate the conveyer lines, a rock crusher, and ventilating fan.

In the operation of the breaker, improved working conditions have been attained by the installation of a 75-horsepower motor, which drives an exhaust fan for clearing the breaker of dust.

Owing to the number of induction motors used at this colliery, the question of maintaining a high power factor is an important one, and it has therefore been decided to substitute a 100 kva. synchronous motor for the 75-horsepower induction motor now driving the fan. This will mean that the synchronous motor will be loaded to approximately 70 per cent. of its capacity, and the necessary leading current for raising the power factor locally will be most economically obtained.

Practically all of the transformers used in this equipment are three phase, 60 cycle, and the cables are carried into the mines through bore holes or in the hoisting shafts, where they occupy space that could not otherwise be utilized.

The electrical apparatus described above was supplied by the General Electric Co.

采

Correspondence

采

Position of Stoppings to Withstand Explosions

Editor Mines and Minerals:

SIR:—I noticed an article in April MINES AND MINERALS on the position of stoppings to withstand an explosion. This question arises as to the location of stoppings in breakthroughs or cross-cuts, whether there is any choice in the location of stoppings to withstand an explosion.

The location of stoppings, in my opinion, would not make any difference, although it is customary to build them on the intake side. In gaseous mines, if the stoppings were built the full thickness of the pillar and well packed with rock and fine dirt to the roof, and both faces of the stopping laid in cement for 18 inches or 2 feet in thickness, I think they would withstand an explosion of gas or coal dust.

It would also stop dust from accumulating in cross-cuts and lessen the dust explosions to some extent and would also make it much easier to restore ventilation after an explosion.

I merely suggest this system for headings and airways.

Coyne, Pa.

P. J. CONWAY

Difficulties in Sampling Free Milling Gold Ore

Editor Mines and Minerals:

SIR:—I should like to have someone's candid opinion on the sampling of free-milling gold ore. It has been my experience to have duplicate assays from the same pulp vary widely. I have run as many as six from the same pulp under exactly the same conditions, and have had three give the same results, two to agree but giving another result, and the sixth to give a different result. Assume the ore only contains two particles of gold just the size of the sieve hole, that it is thoroughly mixed, and two samples taken. If one particle happens to get in each charge, well and good; but if they happened to get into one charge the true value would be doubled. The larger the particles the greater will be the difference in the duplicates. Assume an ore contained fine gold and some coarser but able to pass through the sieve; and assume the fine gold divides evenly in the pulp, but the coarse particles, being fewer, do not. If three coarse particles got into one charge and one into the duplicate, the results would be very different. For this reason free-milling ore is difficult to assay, if not impossible, on account of the samples. The difficulty increases with the gold contents, and control assays would likely be as far from the true value as the shippers' or buyers' assays. I am aware that the finer the pulp is crushed the more likely assays are to agree, but even then there must be a discrepancy due to sampling. If I am wrong I should be obliged to any one who will set me right.

N. R.

Lambertville, N. J.

Humidifying Mine Air

Editor Mines and Minerals:

SIR:—The letter from James Dalrymple, State Inspector of Coal Mines, dated from Denver, Colo., which appears in your issue of April, attracted the notice of the writer, and he wishes to point out how very misleading it is to state the humidity of a mine in "percentage of humidity." Thus, taking Mr. Dalrymple's own figures, what was really accomplished? His first temperature of 26 degrees showed a water content of only 1.7 grains per cubic foot. Underground he had 1.1 grains per cubic foot of air, and 100 feet inside the radiator for 61 degrees he had only .84 grain per cubic foot, whereas air of this temperature might have carried 6 grains per cubic foot. Inside of the fourth south he had only 6 grains for his saturation. His highest content was at J.5, where 90 per cent. saturation only gave him 9.5

grains per cubic foot. The large range of these figures shows to any mind that the only basis on which a true comparison can be made of the value or otherwise of watering or humidifying mine air, is by stating the actual water vapor content in grains per cubic foot of air, and not in percentages of humidity.

Experiments made on the explosive force exerted by mixtures of explosive gases and air, have proved that the greatest force is developed when the mixture contains 5 per cent. of water vapor in the form of steam; therefore water vapor can have no value as the restrainer of an explosive flame until and *after* the air contains 25 grains of water vapor per cubic foot of the mixture.

The sole value of damp air is that it may cause dust to fall and deposit itself on the floor and sides of the roadways more readily than when the air is dry.

JAMES ASHWORTH

Humidifying Mine Air

Editor Mines and Minerals:

SIR:—In reply to the letter from James Dalrymple in your April issue, permit me to say that the question in my previous letter, "If there are mine roofs which will not stand sprinkling, and steam is not for the purpose of furnishing water for wetting the mine, how are such roofs to be made wet?" has not been answered.

I wish to assure Mr. Dalrymple that this discussion is not personal. Our aim is to prevent explosions of coal dust by the most scientific, sanitary, and economical methods possible. He is not the sole advocate of different steam arrangements; there are many others.

Your correspondent's letter contains inaccuracies. I have visited so-called humidified mines, but it would be invidious on my part to mention names, and discourteous to the officials who were kind enough to show me around.

At one mine I have in mind, the radiators and steam pipes are not in the haulage road, or main entry, they are in the back entry. A blowing fan is used, both roads are intake airways, and the bulk of the ingoing air travels the back entry; that is one reason why there is no fog in the haulage road.

Mr. Dalrymple states that if the temperature of the ingoing air is raised sufficiently to absorb the steam, and carry it in the form of vapor, it will be invisible to the eye. I would ask, What is vapor? It is steam which is invisible. And steam has a certain temperature. It would be interesting, therefore, to know what is considered the proper temperature for ingoing air under the circumstances.

The following temperatures were taken in the mine referred to above, inby side of radiators, about 300 feet from the fan, but outby the point where steam is admitted into the air-current: Dry, 56; wet, 40; relative humidity, 25.

I traveled the main entry, or haulage road, for a distance of about 1,200 feet beyond the point where steam is admitted in the back entry and took the following readings in the haulage road; the back entry was not traveled on account of vapor, and condensation water which was knee deep: Dry, 49; wet, 45; relative humidity, 76.

I passed through an open cross-cut into the back entry, and took readings opposite the last point in the main entry (the roof in the back entry at this point was dry): Dry, 54¾; wet, 53¾; relative humidity, 95.

I traveled the main entry to a point about 1 mile from the mouth of the mine, and took the following readings: Dry, 54; wet, 51¾; relative humidity, 88.

Readings in back entry 1 mile from mouth (roof quite dry) were: Dry, 59; wet, 56¾; relative humidity, 86.

Readings in main entry 10,000 feet from mouth of mine showed: Dry, 60½; wet, 59; relative humidity, 92.

In the furthestmost inby working place, safety lamps are used in this place on account of dust raised during loading opera-

tions, not on account of gas. The readings were: Dry, 79; wet, 76; relative humidity, 88.

It will be noticed that the face temperature is 79° F. And if the humidity was 100 per cent., the conditions would not be sanitary for men to work in.

Another important condition, worth particular attention, is that the mine is not kept damp by humidification from the radiators, and steam. Four men are employed constantly sprinkling with hose, two on the day shift and two at night. Some parts of the haulage road can not be sprinkled in the daytime on account of the locomotives slipping on the wet rails.

As previously mentioned, safety lamps are used in the working place visited to guard against a dust explosion; not on account of gas. Is it not one of the principal arguments of some of the advocates of steam that humidification keeps the dust damp in the working places?

In the Rocky Mountain states there is, generally speaking, a scarcity of water. But there is an abundance of adobe dust. And the paramount question is: Is it safer, more economical, and sanitary to rely on water instead of stone dust, or will the use of water, either from a hose, or in the form of vapor, or both, give us the constant, unvarying conditions tending to safety that general schistification will give us?

SAMUEL DEAN

Coal Washing

Editor Mines and Minerals:

SIR:—I note the letters from George J. Wethers and Arthur Langerfeld as published in the April issue of MINES AND MINERALS. I wish first to state that my own experience has been almost entirely in the washing of bituminous coal, while these gentlemen, I assume, are engaged in the anthracite field. However, I see no reason why my data should not apply to their propositions, and the object of my article is to bring out such men as Mr. Wethers and Mr. Langerfeld and have them and others that will, state their ideas; for, in this manner, I feel that in the end, standard methods and formulas will be agreed upon, which will make coal-washing methods and reports more uniform. I will first answer Mr. Wethers' letter.

Regarding his statement that in some cases "good coal sinks and also refuse floats," I have found these to be very rare in bituminous coal tests, though it may happen more frequently with anthracite. I assume that he does not mean that all the good coal sinks and all the refuse floats, otherwise it would not affect matters much, as in such cases the sink could be saved and the float wasted. However, if part of the good coal sinks and part of the refuse floats, is it not true that this same difficulty would be encountered in trying to make a separation on any form of jig or washery machine? Do we not depend entirely upon a difference in specific gravity to obtain a separation in either a float test or by washing on jigs, etc.? This I consider the valuable function of the float test, as it separates on identically the same principle as all washing machines—specific gravity. The value of the float test to my mind is that it can be and must be used under only such conditions as are available for the proposition in hand.

I agree with him fully regarding the correct plant equipment necessary. Unfortunately it is only too true that jigs are frequently crowded beyond capacity that greater production may result and the cost of washing per ton be reduced, but this is inexcusable. It reminds me of something very often seen. A coal company will employ a chemist and go to considerable expense to analyze the coal and refuse, and then will not take the proper steps to permit the chemist to obtain samples which are representative, and then the company will wonder why the results from the laboratory are not consistent or to be relied upon. The same is true of the jig, for if it is desired to wash the coal, then why not do it right and not expect more of the jigs than they were ever built to do?

The last paragraph of Mr. Wethers' letter leads me to feel that he has not entirely understood the full intent of my article. In fact his last statement is: "It must be understood that I am speaking of the possible, not the actual, as I believe the plants are very scarce that are operating at 100 per cent. on the refuse end, and should there be any, I believe reports should be made in this way: The slate end being perfect and the coal product marketable, should give the 100 per cent. plant efficiency."

If he has read my paper carefully he will remember that everything therein is based upon the fact that first of all, by the "preliminary" float tests, it is determined just what separation can be made, or should be possible, to obtain a washed product that is marketable. My formulas are not based upon any fixed grade or quality of marketable product, but are such that for each and every proposition the highest limit, for instance, of ash is determined before even a float test is made, and the series of preliminary float tests is made only for the purpose of showing the necessary separation to obtain a product suitable for the proposition in hand. In other words, if 15 per cent. ash is what is wanted, but 18-per-cent.-ash coal is "marketable," then may I ask, why should it be said that the 15-per-cent.-ash coal is wanted? In such cases, I should say that the preliminary float tests should be made to determine the separation necessary to produce a product of 18 per cent. ash content, and the bath giving such result would then be the "permissible" bath. Therefore, may I not truthfully ask if my 100 per cent. efficiency is not also most positively based on—"the slate end being perfect and the coal product marketable, should give the desired 100 per cent. plant efficiency?"

Regarding the other data given, where different sizes are washed, I believe the formulas and method can be adapted to such propositions and yet remain basically the same. My data as given have to do more directly with coking coal propositions, or domestic coal where only certain sizes are washed separately. I should like to go into this matter more fully, but space for such letters I know would not permit of the length necessary.

Regarding Mr. Langerfeld's letter, I think he did not grasp the meaning of these tests or of the method. I know that some like to divide the coal sample, by means of the float test, into several samples ranging from the pure rock on down to the bony coals and finally the very good coal. This, in my opinion, has but little value as helpful data in the operation of a washery, for the reason that such separation can not be and are not made in a washery. By the preliminary tests are determined just how much of the "nearly as good bony coal" can be put in with the good coal without raising the ash content beyond the limit placed for a "marketable" coal. I should like to go into this discussion further, but, as before stated, it would require too long a letter. However, regarding the bony coal containing the iron in combination, I think that if a piece of coal contained sufficient iron to cause it to sink in the float test, it would also sink with the refuse in the jig bed and go out as refuse. In some cases, finer crushing might help matters, if it were not a domestic coal proposition. To my mind it is all a matter of what one wants to take out that is first to be determined, and then the float tests can be made to suit.

Last of all I wish to again state that my whole method is based upon the fact that the float tests can be and should be made in an exactly similar manner to that which must be employed in the actual washing of the coal.

G. R. DELAMATER

采 采

To find the size of motor or engine required to drive a fan under average mine conditions: Multiply the number of cubic feet of air by the water gauge and divide this product by 4,500. If a fan is delivering 100,000 cubic feet of air at 2-inch water gauge, what size motor or engine will be required to drive it?

$$\text{Solution } \frac{100,000 \times 2}{4,500} = 44.4 \text{ horsepower.}$$

Reviving Suffocated Miners

Automatic Apparatus for Producing Artificial Respiration and Administering Oxygen

By Henry Hale

In the mine disasters throughout the world more deaths are caused by inhaling noxious vapors than by explosions of gases. Frequently the victims are so overcome that they finally die after being rescued, because the rescuers have had no way of expelling the poison from the body.

A device has been invented which has proved its efficiency in reviving those overcome by afterdamp. A more scientific name for the "pulmotor," as it is termed by the mineworker, is "automatic resuscitation apparatus." This title explains the method of operation and what it accomplishes if applied in time to the person of the victim. It is a mechanical idea which has for its purpose the resuscitation of persons who are overcome through inhalation of poisonous gases, by drowning, or by electric current. The operation of the device consists in inflating and deflating the lungs by means of oxygen, and so setting up artificial respiration.

The apparatus consists of a cylinder in which oxygen is stored under a pressure up to 125 atmospheres, a blowing and suction valve actuated by two accordion bellows, a face mask which encloses the mouth and nose, and makes an air-tight connection with the face. To the mask are attached two flexible tubes, leading to the blowing and suction valve, respectively.

When the mask is set air-tight on the face and the oxygen turned on, the pulmotor works automatically. Oxygen is forced into the lungs until a pressure of 4 inches of the water gauge is reached, which pressure is in connection with one of the accordion bellows, and owing to the elongation of the bellows under the pressure, the valves are turned and the pressure in the lungs released. The suction valve immediately begins operation and continues to exhaust the oxygen from the lungs until a vacuum of 4 inches of the water gauge is reached. The oxygen used for creating this partial vacuum, elongates the second accordion bellows and changes the position of the valve, allowing the oxygen again to be forced into the lungs. A lever enables the inflow and outflow of oxygen to be regulated by hand, independent of the automatic device.

The application necessitates placing the victim on his back, in which position the tongue may fall to the back part of the throat allowing the soft palate to close the larynx. To overcome his condition, a flexible rubber tube is attached to the upper part of the face mask which will admit of grasping the tongue with a pair of forceps and withdrawing it sufficiently to raise the soft palate. Another type of mask is one which fits over the nose and nostrils only, allowing the mouth to be free. With the use of this nose mask, the tongue may be withdrawn and held between the teeth and lips, with sufficient pressure to hold it in place and make the mouth air-tight. For the successful use of the apparatus it is necessary that an air-tight fit be made with the type of mask used.

Attached to the lid of the pulmotor box is an inhalation device which may be substituted for the pulmotor as soon as the subject under treatment recovers the involuntary action of the lungs. This device is fitted with a rubber bag, which holds 2 liters of oxygen when inflated, and a metallic mask which fits over the mouth and nose and which may be held in place with a rubber band passing around the head.

By the action of the pulmotor, the flow of the inhaled and exhaled air is produced by a single nozzle, the reversal from pressure (inhalation) to suction (exhalation) being effected automatically. The rhythm of respiration adjusts itself automatically according to the dimensions of the lungs. Both delivery and suction are harmless to the organism.

In this way a remarkable result is produced. What is apparently a completely lifeless body, begins to breathe regularly as soon as the pulmotor is placed in connection with it. If even the slightest trace of blood circulation, through the action of the heart be present in the body, the lungs are supplied with oxygen just as in natural respiration, so that the most favorable conditions for resuscitation are provided.

To set the apparatus in operation, the lid of the box is turned back on its hinges, in the same manner as a trunk. The case contains two entirely separate machines: an oxygen breathing apparatus, for ordinary oxygen inhalation, mounted on the lid of the case, and the special apparatus for artificial breathing, housed in the case itself. The two have an oxygen cylinder, and a pressure-reducing valve, and either of them can be set in operation singly by turning a suitably arranged lever. The steel oxygen cylinder is closed by a valve, and as soon as this valve is opened, one or the other of the apparatus begins to work. This cylinder contains $11\frac{1}{2}$ cubic feet of oxygen.

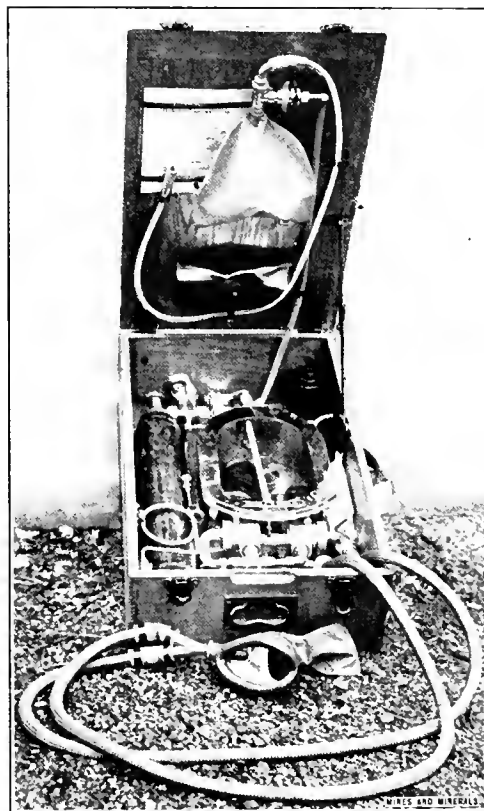

AUTOMATIC RESUSCITATION APPARATUS

When a full cylinder is used, the pulmotor for artificial respiration will continue in operation for 40 minutes in succession. The oxygen passes from the reducing valve to an injector, which has the property of drawing in a large volume of air with a certain force of suction, and propelling that air forwards with equal pressure, through the flexible tube in front of the injector. This suction and delivery injector therefore serves as a motor, alternately filling the lungs by pressure and emptying them by suction, and no injury to the lung tissues can be produced by working in this manner. Another important feature of the apparatus is the air-reversing chamber, provided with frictionless reversing valves which are not affected by either dirt or liquid, nor do they fail to act after the apparatus has been left unused for a long time.

采采

Room-and-pillar mining becomes impractical from the standpoint of economy when the width of the pillars is twice the width of the rooms.

Answers to Examination Questions

Examination for First-Class Certificate of Competency, New South Wales, Australia, 1911

QUES. 1.—Calculate the delivery of water per minute in gallons from the following data: Length of pipe, 730 yards; diameter of pipe, 7 inches; pressure, 100 pounds to the square inch.

ANS.—We may assume that the pressure is that caused by the head, or difference in elevation between the inlet and discharge ends of the pipe, that the pipe "runs full," etc. Using D'Arcy's formula,

$$Q = .89 \sqrt{\frac{d^5 h}{l}} = .89 \frac{d^2}{l} \sqrt{d h}$$

in which

Q = cubic feet of water discharged per second;

$$h = \text{head} = \frac{100}{.434} = 230.41 \text{ feet;}$$

$$l = \text{length of pipe} = 730 \times 3 = 2,190 \text{ feet;}$$

d = diameter of pipe in feet = $\frac{7}{12} = .5833$, and substituting,

$$Q = .89 \times \frac{2}{.5833} \times \sqrt{.5833 \times 230.41} = .89 \times .34 \times \sqrt{.061371} \\ = .89 \times .34 \times .248 = .075 \text{ cubic foot per second.}$$

Since there are 7.48 gallons in each cubic foot, the flow per minute is $.075 \times 60 \times 7.48 = 33.66$ gallons.

QUES. 2.—There are 20 rooms, spaced 40 feet center to center, on an entry. The coal is clean, 9 feet thick, and the rooms are 25 feet wide and 310 feet long from the rib of the room side of the entry to the face. It is estimated that the coal taken out in driving the breakthroughs is equal to that left in the ground in the entry stumps by reason of the narrowing of the rooms at the necks. The specific gravity of the coal being 1.40, (a) what was the total tonnage originally contained in this area? (b) What percentage of coal was extracted in driving up the rooms? (c) If 66 $\frac{2}{3}$ per cent. of the coal in the pillars is recovered, what will be the tonnage thus regained and what will be the percentage of the original tonnage lost in the pillars?

ANS.—(a) There are 20 rooms, each 25 feet wide, and the space occupied by their faces = $20 \times 25 = 500$ feet. There are $20 - 1 = 19$ pillars, each $40 - 25 = 15$ feet wide. The space occupied by their faces is $19 \times 15 = 285$ feet. The total length of face is therefore, $500 + 285 = 785$ feet. The cubic contents of the original area are therefore equal to $785 \times 310 \times 9 = 2,190,150$ cubic feet. The tonnage is equal to $\frac{2,190,150 \times 62.5 \times 1.40}{2,000} = 95,719$ tons.

(b) There are 19 pillars, 15 feet wide, 9 feet high, and 310 feet long. They contain $19 \times 15 \times 9 \times 310 = 795,150$ cubic feet. This is equal to $\frac{795,150 \times 62.5 \times 1.40}{2,000} = 34,788$ tons in the pillars. And $\frac{34,788}{95,719} = 36.34$ per cent., is the proportion of the original coal left in the pillars.

(c) If 66 $\frac{2}{3}$ per cent. of the pillar coal is recovered, 33 $\frac{1}{3}$ per cent., or one-third, is lost; hence, $\frac{34,788}{3} = 11,596 =$ tonnage lost in the pillars. As there were originally 95,719 tons in the unworked block, the percentage of loss is $\frac{11,596}{95,719} = 12.12$ per cent. From this the recovery of coal is $100 - 12.12 = 87.88$ per cent., which may be considered fair average practice.

QUES. 3.—A clause in a lease provided that 40 per cent. of the coal left in the pillars in room driving. Neglecting the extra block left in the entry stumps, which will be about offset by the coal recovered in driving the breakthroughs, how wide must the pillars be if the rooms are 21 feet wide?

ANS.—Since the length and height (thickness of the coal) are the same for both rooms and pillars, they are constants which may

be dropped. If x = width of pillar, $21 + x$ = width of both room and pillar, and $\frac{x}{21+x}$ = proportion of pillar coal to total original coal.

But the required proportion of pillar to total coal is as 40 to 100, or $\frac{40}{100}$. From this, $\frac{x}{21+x} = \frac{40}{100}$. Solving for x we have 14 feet as the width of the pillar. This may be, perhaps, more easily understood, if we let L = length of both room and pillar, and T = thickness of the coal, and x , as before, equal the unknown thickness of the pillar. Then,

$$21 L T = \text{volume of coal in the room;}$$

$$x L T = \text{volume of coal in the pillar.}$$

$21 L T + x L T = (21+x) L T =$ volume of both room and pillar; that is, of the solid. As before, $\frac{x L T}{(21+x) L T} = \frac{40}{100}$, which may be reduced to the same form as above, since the expression $L T$ is common to both terms of the fraction.

QUES. 4.—The diameter of a drum is 11 feet; stroke of engine, 6 feet; depth of shaft, 600 yards; speed of piston, 400 feet per minute. What time is occupied in winding?

ANS.—Since the drum is 11 feet in diameter, the distance traveled by the rope in one revolution is $11 \times 3.1416 = 34.56$ feet. Since the piston speed is 400 feet and the number of strokes six, the number of revolutions is $400 \div 6 \times 2 = 33\frac{1}{3}$ per minute. The speed of the rope is $34.56 \times 33\frac{1}{3} = 1,152$ feet per minute. As the shaft is 600 yards, or 1,800 feet deep, the time of hoisting is $\frac{1,800}{1,152} = 1.562$ minutes, or 1 minute 34 seconds.

QUES. 5.—The stone from two shafts, 20 feet in diameter and 1,200 feet deep, is used for making a railway embankment. This embankment is 30 feet wide at base, 10 feet at top, and 10 feet thick. What is its length? The proportion of "solid" to "broken" stone is 55 to 100.

ANS.—The volume of the stone in the two shafts is equal to $2 \times \frac{2}{20} \times 7854 \times 1,200 = 753,984$ cubic feet; that is, it is equal to the volume of two cylinders each 20 feet in diameter and 1,200 feet long. As the proportion of solid to broken stone, that is, the increase in space caused by the stone being dumped loosely in the fill, is as 55 to 100, the rock from the two shafts will occupy $753,984 \times \frac{100}{55} = 1,370,880$ cubic feet when dumped.

The area of the cross-section of the embankment is $\frac{30+10}{2} \times 10 = 200$ square feet. Having the cubic feet or volume of the fill and its cross-section, its length is $\frac{1,370,880}{200} = 6,854.40$ feet.

QUES. 6.—How would you determine whether the workings of a colliery had encroached on adjoining lands?

ANS.—We may assume that the adjoining property has not been worked, in which case the map alone will tell whether or not we are near or "over the line." If, as is customary in American practice, the entries are driven "on points," and the survey stations are shown on the map, the superintendent, on approaching the property line, should measure up from the last survey station to the face and mark this distance on his map or blueprint. The distance from this point to the property line is, of course, the pillar still remaining between the workings. The required thickness of this pillar varies according to the laws of the different states. On the other hand, if the adjoining property be in operation, while the approach thereto is best determined by the map, yet it is possible that a squeeze carried over from abandoned neighboring workings may show in the heading, or there may even be an increased seepage of water from the face, due to water backed up in the nearby mine. In either case, the only safe guide as to the whereabouts of any mine working is a good map.

QUES. 7.—Enumerate the principal sources of error in colliery and surface surveys, and state how you would guard against them.

Ans.—The principal sources of error in surveys, assuming them to have been made with an ordinary compass and tape, arise from want of precision and accuracy in the instruments used. The compass is not precise because it cannot be read nearer than within $\frac{1}{4}$ degree, which is too great a possible error for any but the roughest work. It is impossible to take accurate sights with a compass, as it does not possess a telescope with cross-hairs for accurately bisecting the objects sighted on and to. It is also very inaccurate because of its susceptibility to attraction by nearby metallic objects,

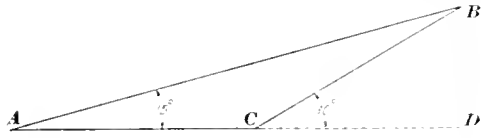

FIG. 1

such as rails, iron pipes, copper wires, and the like. The use of the compass in making underground surveys should be prohibited by statute. This want of precision and accuracy on the part of the compass may be overcome by the use of an engineer's transit, provided with a telescope with the customary cross-hairs, and with double verniers, reading at least to a single minute.

The surveyors' chain is no longer used underground and is fast disappearing from surface work. It is liable to be inaccurate, owing to the very many wearing surfaces, so that the average chain is usually too long (by the amount of wear) and, consequently, gives measurements shorter than the true ones. There is also present in the use of a chain, the strong possibility, particularly when used underground, that the links may be twisted, and the chain thereby shortened, in which case the measurements given by it will be too long. The chain should be replaced by a tape, one 300 to 400 feet in length, where possible.

In ordinary American practice, and under normal conditions, and using a transit in good adjustment and a 400-foot tape, it is unusual for the error in closure of a mine survey to be greater than 1 foot in 10,000 feet, and not infrequently it is as low as 1 foot in 20,000.

QUES. 8.—The angular height of a stack was found to be 15 degrees, and at a point 100 yards nearer it was observed to be 30 degrees. What was its actual height?

Ans.—In Fig. 1, let BD = the height of the stack. Considering the triangle BAC , the angle $BAC = 180^\circ - 30^\circ = 150^\circ$, and the side $AC = 100$ yards = 300 feet. The angle $ABC = 180^\circ - (BAC + BCA) = 180^\circ - (15^\circ + 150^\circ) = 15^\circ$. Therefore, since the angles BAC and ABC are equal to one another (15°), the two sides AC and BC are equal to one another, or each is 100 yards, 300 feet, long.

In the right-angled triangle BCD , we have the side $BC = 300$ feet and the angle $BCD = 30^\circ$. From this the side $BD = BC \sin C = 300 \times .50000 = 150$ feet = height of the stack.

QUES. 9.—Calculate the area of the accompanying rectangular figure, Fig. 2, from the data given. Give proof of your work.

$AB = 4,000$ links
 $CD = 1,800$ links

Angle $BCD = 75^\circ$

Ans.—Draw a diagram, Fig. 2. The area of the parallelogram is equal to the product of its two unknown sides, x and y , or area $= xy$. Draw DF perpendicular to AB . In the right-angled triangle BCD , the length of the hypotenuse, $CD = 1,800$ links, and the angle $BCD = 75^\circ$. Hence, the side $FD = DC \sin 75^\circ = 1,800 \times .96598 = 1,738.765$ chains. The triangles BFD and EBA are equiangular and similar as the side DE is perpendicular to the side AB , and the side BD is perpendicular to the side EB ; hence, similar sides are proportional. From this we have, $x : BA = DF : y$, or $xy =$ area of parallelogram $= BA \times DF = 4,000 \times 1,738.765 = 6,955,056$ square links = 69.55 acres.

QUES. 10.—A property has been exhausted above water level, and 3,500 acres, estimated to be capable of yielding 6,000 tons per acre, remained unworked, but to the dip. It has been shown that a saving of 2.6 cents a ton in haulage may be effected by opening

a new mine with a pair of shafts at the extreme dip, as all the haulage will be down hill, etc. If this is done it will be necessary to scrap the present plant at a dead loss of \$150,000. It will also be necessary to borrow the money—\$300,000—for the new plant, which money must be repaid at the end of 20 years. Interest at 5 per cent., payable annually, is the best rate at which the money can be secured. Making no allowance for depreciation, etc., do you think this move will be profitable?

Ans.—The total tonnage is $3,500 \times 6,000 = 21,000,000$. The saving, by moving the plant, at 2.6 cents a ton, is equal to \$546,000. The cost of the new plant will be as follows:

Loss of present plant.....	\$150,000
Borrowed for new plant.....	300,000
Interest on borrowed money, 5 per cent. for 20 years.....	300,000
Cost of change.....	\$750,000
Gain by change.....	546,000
Net loss by change.....	\$204,000

This is equal to a loss of about 1 cent per ton on the remaining coal in the field, and further shows what a burden interest payments are.

QUES. 11.—You are called upon to estimate the probable depth to a coal seam at a point 2 miles from proved depths. How would you proceed? What factor or factors might come in to interfere with your calculations?

Ans.—We may assume that the coal outcrops and is opened by a slope. The depth of the coal 2 miles beyond the end of the present workings will depend upon the rise or fall in both the surface and the seam. The change in the contour of the surface may be readily determined by an ordinary leveling instrument, and is to be added to the dip of the seam if the surface rises from the drift mouth, and to be deducted if the surface falls. The change in level underground is a more complex problem. Should the improbable happen and the dip continue at its old angle, without changes, for a distance of 2 miles, the depth of the seam may be calculated readily. But that the dip will be uniform for any such distance is practically impossible. Even so slight a change as 1 foot in the 100 will make a difference of 105.60 feet at the end of 2 miles. Further, in all fields there is the possibility, and in many fields the probability of encountering true faults, that is, faults of dislocation, in which one side of the seam has gone an unknown amount up or down along the foot-wall. The two uncertainties then are the probability of a change in dip and the occurrence of a fault, neither of which may be predetermined.

QUES. 12.—Shot firing. It is necessary to fire shots in a district, dry and dusty, with a little gas found occasionally. Say what explosive you would use, how you would fire it, and what precautions you would take to guard against accident?

Ans.—The powder used should be one of the short-flamed "permissibles," approved by the Bureau of Mines, tamped with

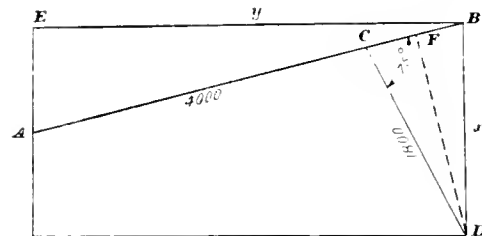

FIG. 2

clay, and fired after the men have left the mine by battery, either from the surface or by shot firers. The place should be examined before firing for any undue amount of gas, which, if present, should be removed. Dust should not be allowed to accumulate at the face or in the workings, should as far as possible be loaded out from the mine, which should be thoroughly watered. If no water, or but a limited quantity of water is available, rock-dust zones should be established and rock dust blown over the loose material in the rooms.

QUES. 13.—In boring, two beds of coal were passed through, the intervening strata being 120 feet thick; but, in subsequently working the coal, only one seam was found. How can you account for the boring results? If a sketch will help you answer, give it.

ANS.—The failure to meet a second seam may be accounted for by assuming that the drill hole, *A B*, Fig. 3, was sunk through an upthrow fault plane, as shown in the sketch. Cases such as this have been met in practice and the error has not been discovered until the workings, driven on the lower portion of the

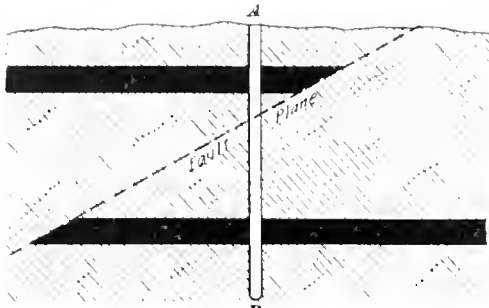

FIG. 3

seam, encountered the fault. It is probable that careful comparison of the cores of the seam and the overlying rocks would at least have shown the high probability of the two cores being from the same seam and might have established it as a fact.

QUES. 14.—What method of reducing temperatures would you suggest in very deep mines? How is it in a general way that in deep mines high temperatures are not so trying to the worker as lower temperatures in shallow mines?

ANS.—While it is considered bad practice to cool the intake air, it may be done to a certain extent by hanging canvas or burlap curtains at the entrance and keeping them constantly moistened with as cold water as is readily obtainable. The air passing over them is cooled and absorbs moisture, probably up to the point of saturation. As a rule deep workings are dryer than shallow ones and it is a well-recognized fact that a man can stand very high temperatures if the air be perfectly dry. The reason why deep workings are dryer than more shallow ones may be best shown by an illustration. In most coal fields the mean annual temperature of the place is not far from 50 degrees, and this is the mine temperature when unaffected by the heat given off by the men, mules, lamps, etc., and that due to the interior heat of the earth, which latter we may assume to increase at the rate of 1 degree for every 60 feet of depth below the surface. If we have a shaft 1,800 feet deep, the rock temperature at the bottom will be 30 degrees higher than at the surface, and the thermometer will register a temperature of 80 degrees. Granting that the air enters fully saturated at a temperature of 50 degrees, 100,000 cubic feet will contain 6.979 gallons of water. At 80 degrees, the same volume of air requires 18.776 gallons for its saturation. In other words, the relative humidity at the face of the working will be little over 30 per cent., which is extremely dry. Another effect of the dryness is to increase the rate of evaporation from the skin, and this tends to coolness, and the more rapid the evaporation the greater the degree of coolness experienced. A few drops of ether in the palm of the hand, blown upon, will produce great coolness because of its extremely rapid evaporation. A similar state of affairs takes place in a mine with high velocity dry air-currents.

來 來

Air-Compressor Lubrication

In spite of the care exercised in designing and operating air compressors, disastrous explosions still happen, usually traceable to the presence of inflammable gas in the air lines, due to the improper use of lubricating oils.

A common fault in the lubrication of air compressors and pneumatic tools is to use too much oil, and oil that has too low a

flash point. An air compressor does not require as much oil as a steam cylinder, and it is better to limit the use of oil to a minimum. Oil causes the valves to stick and thereby necessitates frequent cleaning. If kerosene is used to remove the deposit the valves must be taken out, although engineers have been known to introduce kerosene through the air-inlet valves for this purpose. Kerosene will clean the valves, but it is also equally effective in producing an explosion.

The best method is to lubricate air-compressor cylinders with soapy water and flake graphite. Such a mixture provides economical, efficient, and safe lubrication and keeps the valves clean. A little oil should be introduced when shutting down the compressor to prevent any tendency of the soap suds to cause rusting. By this method all dangers attending the use of oil are overcome.

Flake graphite has a tendency to attach itself to metal surfaces and, when thoroughly worked into the inequalities of surfaces, imparts a superficial glaze of high polish and endurance that prevents actual contact, metal to metal, and make it possible for relatively small quantities of fluid lubricants to provide a safe and sufficient film or lubricating layer. Flake graphite is an inert mineral unaffected by any degree of heat attainable in the air compressor cylinder; and it cannot be volatilized, carbonized, or baked into a hard or gummy mass to interfere with the free action of the valves.

來 來

Switch at Navajo Mine, New Mexico

The switch shown in the cut is in use at the Navajo mine of the Victor American Fuel Co., at Gibson, near Gallup, N. Mex., and by reason of its simplicity and the impossibility of its being thrown except through intent, may commend itself to others.

The bar connecting the two latches as well as the joints in the switch rods, to permit of a vertical movement when the switch is thrown, are of the familiar type. The stand is made of two pieces of iron of convenient size, say, $\frac{1}{2}$ in. \times 2 in. in section, and is about 18 inches high when in position beside the track. These frame pieces are bent as shown, Fig. 1, and at the lower ends are turned to form feet or supports by means of which, through holes, the stand is bolted to a heavy tie. The arm, upon the end of which is a weight of some 15 to 18 pounds, is in one piece of $\frac{1}{2}$ " \times 2" iron, bent as shown in the figure, and movable upon a bolt through it and the two sides of the stand.

When a trip is pulled up the hill off the siding and on to the main line the counterweight serves the same purpose as the spring in the familiar spring switch. When a trip is to be dropped into the siding and down the hill the switch must be held open by raising



FIG. 1. SWITCH AT NAVAJO MINE

the counterweight and holding it raised until the trip has passed. It is thus impossible for the switch to be accidentally set for the main line. Unless the weight is deliberately raised with the full knowledge of the trip rider, the main line and most used track is always "clear."

ORE MINING AND METALLURGY

Lake of the Woods Mining District

The Sultana Mine—Efforts to Sink a Shaft at the Bottom of a Lake in 18 Feet of Water

By William J. Richards*

A history of gold mining on the Lake of the Woods would not be complete without mention of the famous Sultana Mine.

On or about the year 1898, some prospectors drifted west from the old Port Arthur silver district to Rat Portage, and began searching for gold among the 14,000 islands of this beautiful lake. Skirting the rocky shores in birch-bark canoes, many important gold discoveries were made, the veins, principally

and the further discovery of a good sized ore body underground, a larger plant was purchased and erected which reduced the cost of mining and milling the ore. The second plant, shown in Fig. 1, comprised a battery of three large boilers, feed-pumps, feedwater heater, a large duplex cross-compound condensing air compressor, air drills, a 150-horsepower Corliss mill engine, an electric-light dynamo, and a 30-stamp mill. The plant was substantially erected by competent men and had every appliance necessary to a first-class gold mining installation. An expert in shaft-house construction from Ishpeming was employed to build a suitable shaft house. A fine duplex hoisting engine of a capacity of 1,500 to 2,000 feet was placed in position and a skip road put in. The plant when completed was in every respect first class and up to date. With a mine producing gold bullion regularly, in

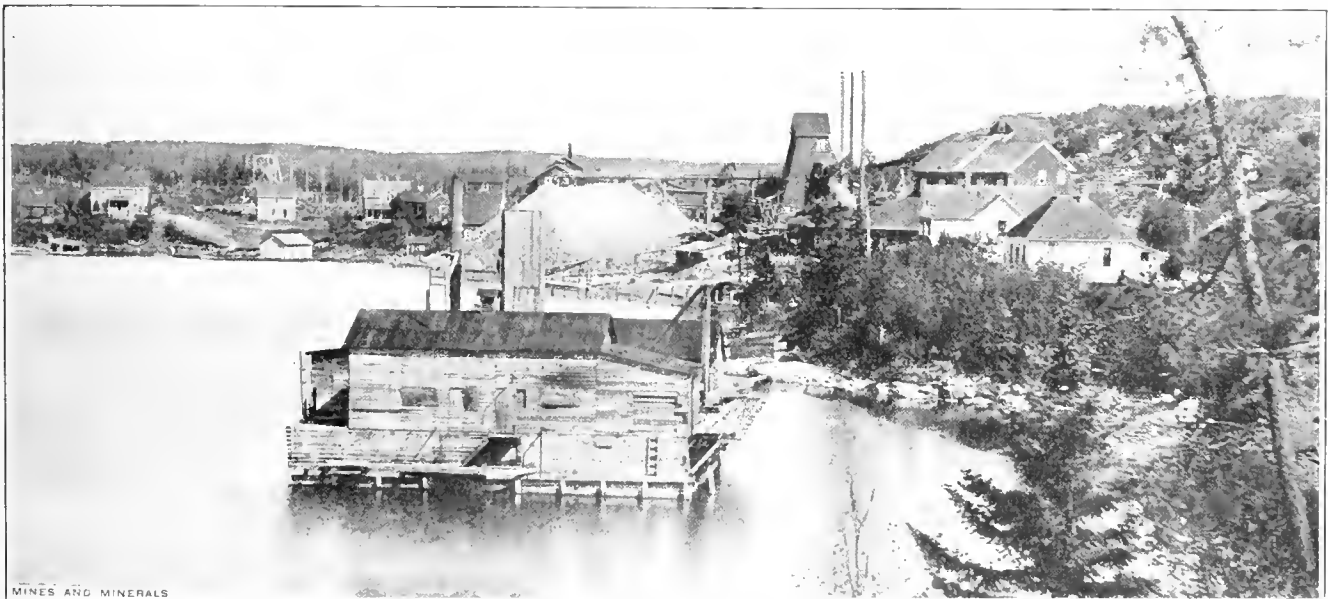

FIG. 1. SULTANA MINE, LAKE OF THE WOODS

quartz, often appeared like ribbons of white continuing down into the depths of the lake. In this section the ancient glaciers have eroded several hundred feet of the surface. Nature not having had time to recover the surface completely with soil or moss, many of the islands are bare rocks, of granite, trap, or schist, with its variations, all probably belonging to the Huronian series. The gold being in quartz, its presence is ascertained by the simple process of crushing in a mortar, and panning. Whenever a good showing is found, the prospector secures the land from the government and tries to interest capital. The first property developed was the Sultana, 7 miles from Rat Portage by water. Mr. John F. Caldwell, of Winnipeg, secured this property from the prospectors, and the outcrop of the vein having been found to be rich in gold, prospect shafts were sunk under his personal direction. The results obtained from these shafts were such that the advice of mining engineers was sought, who advised that work be centered upon sinking the main shaft to a considerable depth. A small plant was therefore installed, which consisted of a steam hoist, a three-drill air compressor, a ten-stamp mill, and the necessary boiler power.

After demonstrating that gold existed in paying quantities,

an unknown district, with stopes of rich free milling gold ore 80 feet wide, it naturally followed that it would attract the cupidity of others. Among those who visited the district was a man named Smith from Ottawa, Canada, to whom Mr. Caldwell courteously granted permission to go underground. At this time the main shaft was 600 feet deep, with levels extended 800 feet along the vein and an air shaft upraised to the surface. Both shafts were not over 300 feet from the lake shore, and the dip of the vein was toward the lake. Mr. Smith evidently took careful note of this, for he immediately returned to Ottawa, and with his associates secured the land under the water along the mine frontage. No one had ever thought of such an outrage being possible, there was no precedent in law; however, Smith's intention was apparently to deprive the Sultana mine of its vein beyond the vertical plane boundaries. This might be understood on land, but mining in 30 feet of water seemed out of the question; nevertheless, some old law, made during the reign of King John of England, which had been forgotten, was used with influence to legalize this injustice. A long and expensive lawsuit forced upon the mine ate up years of honest effort, and this with the increased cost of fuel, even with the greatest heat economy, was a load on the mine. In spite of all these difficulties work was carried on,

* Kenova, Ontario, Can.

the shaft was deepened, and the vein and its enclosing formation was found to dip back again under the island. In the meantime some of the principal shareholders having died, and the report being circulated that the mine had its limits and was subject to constant harassing, had made it difficult to continue the work. The price of fuel also doubled, and as hard times in the financial world are felt sooner in gold than in any other class of

be idle at this time. It must be remembered that the aforementioned sale of water frontage took place about 10 years ago and was not an act of the present administration, who appear anxious and willing to assist the bona fide miner and to protect him in his discovery from any injustice.

柔 柔

Laboratory Test on Cyanide Ore

Method Used to Determine the Suitability of an Ore to Treatment by Cyanide Process

By Linderfelt and Stewart*

Owing to the vast difference in the composition of ores, it is necessary to run a series of tests on an ore to determine whether it is suitable for cyanidation or not, and what process must be used to obtain the best results.

The following system of laboratory treatment, devised by us, has proved satisfactory:

The experience and judgment of the experimenter may largely limit the extent of the work. The silver content of the ore is another important factor. If the ore is a coarse-grained porphyry, well oxidized, and contains, say, .4 ounce of gold and no silver, it is well to start at 4 mesh and work up to 12 mesh, running as follows: 4, 8, and 12-mesh product, the cyanide solution running from 1/2 to 2 pounds. If the ore be fine grained, it will be necessary to grind to a finer mesh, use a longer period

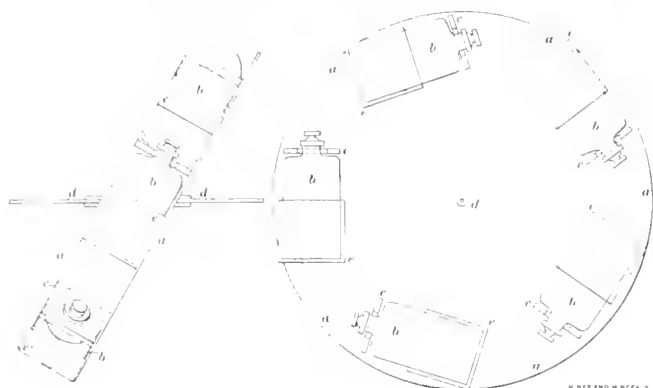
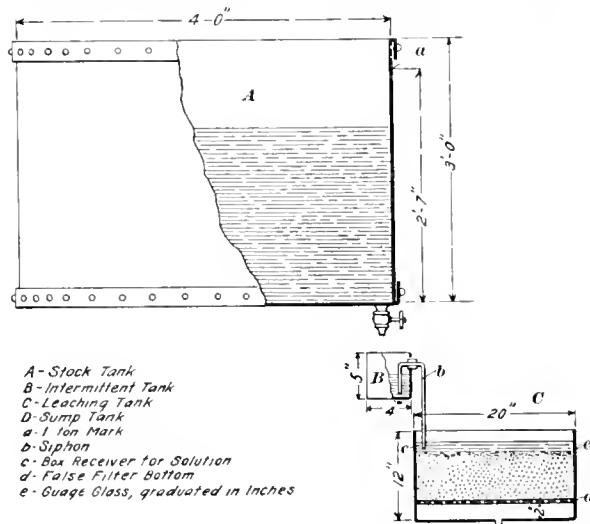

FIG. 1. AGITATOR FOR LABORATORY TESTS

mining, work was discontinued. In the meantime, Smith's company secured a diamond drill and bored through the ice during the winter to establish a point at which to sink a shaft in the lake. When this was done a 60' x 60' x 30' cofferdam was built on an island and towed to the position shown in the illustration, where there was 18 feet of water. It is the float-looking object with the building above it in the foreground, the Sultana property being in the background. The cofferdam was constructed of 7" x 7" timbers placed skin to skin, cross-tied, and spiked together. The timber joints were then calked with oakum and coated with pitch. To obtain stone to sink the cofferdam a quarry was opened on a nearby island. When the bottom was reached a diver placed cement around the edges inside, after which it was pumped out. A steel casing was next sunk through the center of the crib to bedrock, and then a shaft was sunk 200 feet deep. It is not hard to believe that this shaft made plenty of water, which, combined with the apparent inability to locate anything of value in the workings, appears to have discouraged this Smith company, for it ceased operations some 8 years ago. However, they were successful in stopping or holding up the Sultana company, thereby preventing gold production in the district, and preventing capital being secured for many of its promising prospects. At this time the government in power granted large concessions which blanketed large areas of land, and this with the before-mentioned Act, together with the reversal of titles, created so much distrust in the financial world it was impossible to secure capital for development. The Sultana company was forced to spend money that would otherwise have gone into development in an expensive and protracted lawsuit. While this district received a setback from the causes named and through the overproduction of mining stock, it nevertheless has evidences of wealth worthy of investigation, and since the conditions of 8 years ago have changed, investors are able to protect themselves by an examination of the records.

Many improvements, and in fact almost all the important transmission problems in electrical uses of our waterpowers have been overcome. With unlimited hydroelectric power now available at \$12 per horsepower per year and the advent of the producer gas engine, revolutions have taken place in power generation which permit the profitable treatment of ore hitherto valueless. With the natural advantages possessed by this mining camp and the indisputable fact that the Sultana mine paid continuously for 16 years, with indications of large bodies of ore still untraced, there seems to be no good reason why the Sultana mine should be overlooked and that the 30 head of stamps should



- A - Stock Tank
- B - Intermittent Tank
- C - Leaching Tank
- D - Sump Tank
- a - 1 Ton Mark
- b - Siphon
- c - Box Receiver for Solution
- d - False Filter Bottom
- e - Gauge Glass, graduated in Inches

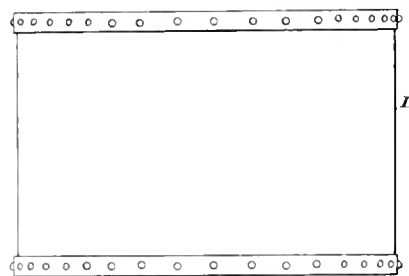

FIG. 2. TANKS FOR CYANIDE TESTS

of leaching, but not necessary to change the strength of cyanide solution.

The ore for the tests must be carefully prepared, quartered, sampled, and assayed and the exact amount for each test weighed out.

The acidity of the ore must be ascertained and the correct amount of protective alkalinity, with a few points excess, must

* Mining and Metallurgical Engineers, Victor, Col.

be added before each test. It is well to add this to the stock solution. The necessary alkalinity may be determined as follows:

Put 224 grams of dry crushed ore in the agitator (described below), fill the bottle half full of hot water and a measured excess of standard caustic-soda solution, and agitate for 30 minutes. Filter and wash carefully, then titrate with a decinormal sulphuric-acid solution. Every cubic centimeter of caustic-soda solution used, indicates one-tenth of a pound of caustic soda necessary for 1 ton of raw ore. The use of an excess of normal solution of caustic soda, hot water, and the long agitation not only neutralizes the soluble acidity, but also as much of the latent acidity as would interfere with the treatment of the ore.

The amount of lime necessary in place of the caustic soda must be computed from the per cent. of CaO in the lime available at the proposed mill.

The agitator, Fig. 1, consists of two wooden disks *a*, 30 inches in diameter and $1\frac{1}{4}$ inches thick, set far enough apart to allow a 1-gallon reagent bottle *b*, to be placed between them. It will readily carry five bottles.

The agitator frame, set on a shafting *d*, at an angle of 60 degrees with the horizontal, is driven at a rate of 15 to 20 revolutions per minute. This not only gives the pulp a longitudinal motion, but a transverse motion as well, thus thoroughly mixing and agitating it.

The frames *e*, for the bottles, constructed of wood, secure them between the two disks at their outer edges and hold them snugly, allowing no play as the agitator revolves. A hinged piece of wood *c*, perforated to fit over the neck of the bottle, holds it in place. The stopper is secured by a bottle stopper clamp.

The apparatus for the cyanide tests consists of a 1-ton storage tank *A*, Fig. 2, 4 feet in diameter and 2 feet 7 inches deep, having a stop-cock; an intermittent tank *B*, 4 inches in diameter and 5 inches high, which has a glass siphon set in a rubber cork coming through the side, 4 inches from the bottom and extending to within half inch of the bottom; a leaching tank *C*, 20 inches in diameter and 12 inches deep, which has a false filter bottom of perforated wood and 8-ounce duck, 2 inches from the bottom of the tank; a gauge glass set in the side, and graduated so that the rate of percolation may be observed, and an outlet for the solution; a 1-ton sump tank *D*, 4 feet in diameter and 2 feet 7 inches deep.

The leaching tank *C* is charged with 100 pounds of ore, which has been carefully prepared, sampled, and assayed, making a layer about 6 inches deep. The storage tank *A* is filled with clear water and the desired per cent. of KCN and the necessary per cent. of protective alkalinity are added. The stop-cock in the bottom of the tank *A* is opened and the solution is allowed to flow into tank *B* until the siphon starts running; it is then shut off and regulated so as to fill the intermittent tank *B* about once every 3 hours. This gives the required intermittent leach to the ore because the siphon does not start running until the tank *B* is full, then empties it into tank *C* in a short space of time.

The time of percolation is noted by means of the gauge glass in the side of tank *C*. After the charge has been leached for the desired length of time, the stop-cock in tank *A* is closed and the solution remaining in tank *C* allowed to drain.

The solution in tank *D* is then titrated for cyanide and alkalinity by the usual methods and the consumption of cyanide is computed. The charge is then washed with clear water. The amount of solution in tank *D* is determined by its depth, the capacity of the tank being known. This enriched solution is then assayed and the total gold and silver contents computed. The gold and silver contents of the charge being known from the initial sampling, the extraction is readily computed. The treated pulp, or tailing, is sampled and assayed as a check on the extraction. This method is used for each of the separate tests.

If the ore is hard and close grained, it is necessary to test the slime because its treatment will be necessary in practice.

The ore is crushed and pulverized so that it will pass a

60-mesh screen; it is then carefully sampled, assayed, and the amount for each test weighed out, usually from 1 to 2 pounds.

The same set of solutions used in the sand treatment is used in the slime treatment. The weighed charge is placed in one of the bottles of the agitator with an amount of measured solution so that the slime will have a specific gravity of about 1.25. The bottles are then placed in the agitator and agitated for the desired length of time. The slime is then filtered and the filtrate is titrated for KCN and alkalinity by the usual methods, and the consumption of cyanide computed. The slime is carefully washed, the gold and silver contents determined and the extraction computed. The treated slime is then sampled and assayed as a check on the extraction.

The tests necessary to determine the process depend entirely on the nature of the ore. In a gold ore, containing little or no silver, the solution should be graded from $\frac{1}{2}$ to 4 pounds at half-pound intervals; the time of leaching should vary from 24 to 120 hours at 24-hour intervals and the size of the ore should vary from 4 to 24 mesh, running as follows: 4, 8, 12, 16, and 24 mesh.

Should the ore contain any quantity of silver, or be a silver ore, the strength of solutions should run from 3 to 10 pounds at 1-pound intervals. The average solution for gold ore is from $1\frac{1}{2}$ to 2 pounds, and for silver ores, from 4 to 8 pounds.

In the slime treatment, the solutions vary as in the sand treatment and the length of agitation is 4 to 12 hours at 4-hour intervals. It is necessary that all the ore should pass a 60-mesh screen for this treatment.

The forms for the return sheets may be readily constructed from the above data and the process determined from the tabulated results, selecting the highest extraction with the smallest consumption of cyanide and the coarsest ore consistent with the other two factors.

The laboratory tests bear a definite relation to the practical work. The rate of percolation, the per cent. of alkalinity necessary to neutralize the acidity of the ore, the strength of cyanide solution required, the period of leaching and the mesh of ore are the same in both laboratory and mill. The extraction, as a rule, is higher in the laboratory than in practice, and it is well to figure the extraction from 10 per cent. to 15 per cent. less than the results of the tests. Thus, if the experiments show an extraction of 98 per cent., the experimenter may guarantee that the process will give an extraction of 80 per cent. to 85 per cent. and report favorably on the ore.

In case the ore has a tendency to slime, slime treatment will be necessary. The mill should then be designed to handle a certain percentage of slime and of sand, using an efficient factor of safety in each case. The percentage of each may be determined as follows:

A weighed amount of ore, say 2 pounds, is crushed and rolled to a mesh slightly larger than that required by the tests. This will give a fair per cent. of slime and sand. The entire product is passed over a 60-mesh screen and as much as possible is worked through. The material remaining on the screen corresponds to the sands and that which passes through, to the slimes. Thus, if the tests indicate 60 per cent. sand and 40 per cent. slime, the mill should be designed to handle 70 per cent. sand and 50 per cent. slime, using 10 per cent. as a factor of safety.

Should the ore require concentrating, a further series of tests will be required. The mill should be primarily designed to handle the ore by the chemical process decided upon, and the mechanical equipment should be installed to accomplish the results in the most economical and efficient manner.

柔 柔

What is known as the Boss process is a method of amalgamating in pans by passing the pulp from one pan to the next in a series, practically making it a process of continuous amalgamation. The chemicals employed are the same as those used in the Washoe process and are principally sodium chloride (salt), copper sulphate (bluestone), and quicksilver.

The Chino Copper Co.

Description of a Large Low Grade Copper Property in New Mexico and Its Development

The Chino Copper Co.'s property is situated in Grant County, southwestern New Mexico, about 20 miles east of Silver City. A branch of the A., T. & S. F. R. R. extends from the main line



CHINO COPPER CO.'S CONCENTRATOR, HURLEY, N. M.

at Whitewater Junction, northerly, to the property. It is about 5 miles from Whitewater to Hurley, where the concentrating plant is located. From this point it is about 8 miles northeast to the mining property.

The mining property consists of 2,652 acres. The mill site, water rights, and other holdings amount to 7,013 acres.

The Chino Copper Co. was formed in May, 1909, to take over the old Santa Rita property which had been worked extensively, but intermittently, for many years. The property is very old and is said to have been worked in 1800. The high-grade ores were shipped on pack mules to Chihuahua, Mexico, and used for making copper coins.

Portions of the property have been opened up in the past by a large number of shafts and extensive irregular workings. Some of the workings were more than 400 feet deep. The principal shafts are the Santa Rita, Romero, and Chino. The Santa Rita shaft is about 530 feet deep.

The early mining operations were carried on in the irregular deposits and veins carrying carbonates and native copper, and rich streaks of ore. When these deposits became less frequent or thinner it was found more profitable to have the work done by leasers. Many Mexicans and Chinese were thus engaged from about 1870 onward. Numerous dumps resulted from these operations aggregating about 150,000 tons, carrying 2 per cent. copper.

The geological formation consists of quartz-diorite, quartz-porphry, and sedimentary rock. Limestone forms a contact to the north and east. The ores are carbonates, sulphides, and native copper, disseminated in the andesite-porphry. The ore bodies lie in a crescent-shaped belt about 500 feet wide and 7,000 feet long, covering about 100 acres. Explorations indicate the existence of more mineralized area outside of this zone, but it has not yet been developed sufficiently for definite determinations.

The Santa Rita Mountains extend approximately north and south. They are a minor range of the main mountain chain and flatten out in the plains about 8 miles south of Santa Rita.

Erosion and other forces have caused occasional breaks in the range, cutting gulleys and otherwise fashioning the primary formations. At some places on the mountainsides the rocks have thus been shaped into bold and irregular exposures. One such exposure, when viewed in approaching Santa Rita from the west,

resembles a "kneeling nun." This is up on the mountainside to the south of the break in the range leading up to Santa Rita. The town lies just north of this exposure and within sight of it.

The country gradually broadens out into a sort of elevated basin as Santa Rita is approached through this gulch or break in the mountains. Possibly in ancient geologic times a dam existed, where the break now is, holding back in the basin the drainage from an extensive mineralized area to the east and north of Santa Rita. This drainage probably carried the copper in solution, which was subsequently precipitated in the present mineralized zone.

The development of the mineral lands began in 1909 and was carried on until about the end of September, 1911, when enough ore was developed to supply a mill of 5,000 tons daily capacity for 30 years. The development was done mainly with well or churn drills, as follows:

The drilling was done regularly in 200 feet squares. The drill holes were spaced closer where any uncertainty existed as to the extent and character of the deposit. Seven to eight drilling machines were used. There were drilled 466 holes, averaging 386 feet in depth. Of these, 386 encountered ore of an average thickness of 107 feet and 82 feet average thickness of barren overburden, or capping. The holes drilled were about 6 inches in diameter.

Each 8 feet or so of the hole was tested separately. The drillings removed from each such section were sampled, assayed, and a concentration test made thereon to determine the degree of concentration and the per cent. of copper recoverable.

Up to October, 1911, 54,970,000 tons of 2.24 per cent. copper ore was developed. Of this quantity about 32,000,000 tons will be mined by steam shovels. The balance lies below the level the steam shovels will attain. This will be attacked by other methods of mining.

The limits of the ore bodies have been determined to the north, east, and south. In the latter direction they extend about 1,000 feet. To the west the extension of the ore bodies has been determined by scout drilling, but the additional tonnage in this direction cannot yet be estimated. It will, however, be large, and extends 1,500 feet or so in this direction.

To January 1, 1912, 1,938,000 cubic yards have been handled by steam shovels. Of this quantity 1,709,000 cubic yards were stripping, and the balance, 377,000 tons, was ore. The cost of



ADOBE FORT, SANTA RITA, SHOPS OF CHINO COPPER CO. IN BACKGROUND

the above steam-shovel work, stripping, and mining, was slightly over 31 cents per cubic yard.

The several sections of the mining property are known as the Santa Rita, Romero, Whim Hill, Hearst, Chino, Montoya, and Carasco sections, some of which were worked in the past through shafts bearing those names. On the Chino and Romero sections portions of the ore deposits come directly to the surface. To the

south and east the ores lie deeper below the surface. On the Carasco section, to the south and east, some very good drillings have been obtained from ground that had not been previously explored.

The Romero, Whim Hill, and Chino sections are now available for steam-shovel work. The upper horizon of these sections contains a large amount of carbonates which in milling has resulted in a low copper extraction. As depth is attained, which will be in a few months, the normal condition of the ore bodies, with sulphides and native copper, will be reached, and the recovery will be greatly improved.

The Hearst section will be ready for steam-shovel work about April; this section is nearly free of carbonates, being mostly clean sulphides.

In connection with the steam-shovel work there are about 11 miles of railroad tracks. The equipment consists of five 90-ton steam shovels and one 40-ton, also 11 locomotives and a complement of dump cars and other accessories.

When the steam shovel is running steadily it can excavate three shovelfuls a minute. If each shovelful amounted to three cubic yards, the capacity would be 540 cubic yards an hour. Some shovels handle more than this. But in practice, due to switching cars and other delays, the actual capacity attained is about one-fifth or one-sixth of the above.

The Chino Copper Co.'s concentrating mill is located at Hurley, about 8 miles southwest of the mine. The site is an admirable location, with ample dumping grounds for tailing. When completed the mill will consist of five units or sections, each having a capacity to treat 1,000 tons of ore in 24 hours.

The building of the first section was started early in 1910, and was put in commission in October, 1911. During November and December following, the mill treated at the rate of 700 tons of ore in 24 hours. The second unit was put in operation in January, 1912, and the two sections treated an average of 800 tons a day, each, at a cost of about 8¼ cents per pound of copper. This gives a profit of \$60,000 a month after deducting all expenses, which is equivalent to \$1.40 profit per ton of ore treated. The third section began treating ore in March. With the three sections running full capacity it is expected to produce copper for 7 cents a pound. The fourth section will be ready in May, and the fifth section in July, 1912.

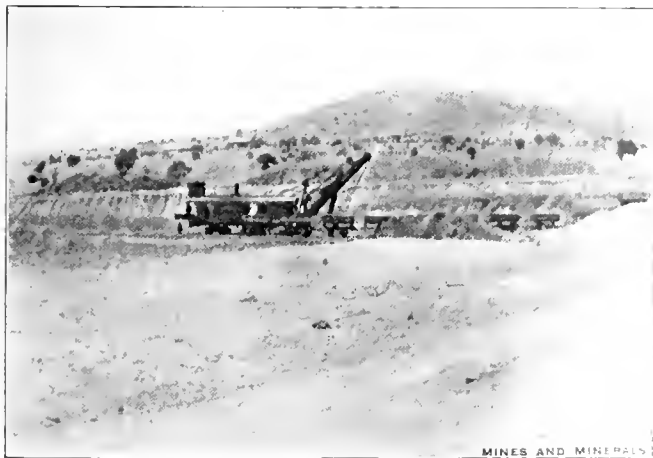

SANTA RITA AND PART OF STEAM SHOVEL PIT

About 14 tons of ore are concentrated into 1 ton of concentrate. About 70 per cent. of the values are recovered. This may be improved upon in time.

The concentrate is shipped to the American Smelting and Refining Co.'s plant at El Paso, Tex., where it is smelted to matte. This product is shipped to Aguas Caliente, Mexico, where it is bessemerized in copper converters of the American Smelting and

Refining Co. and cast into copper bars, which are then shipped to the refineries on the Atlantic seaboard, and electrolytic copper produced therefrom.

The concentrating plant consists of a crusher building, concentrating mill, and power plant. The foundations of the buildings are of concrete. The superstructure is of structural steel housed with corrugated galvanized sheet iron.

The general arrangement of the concentrating plant is as

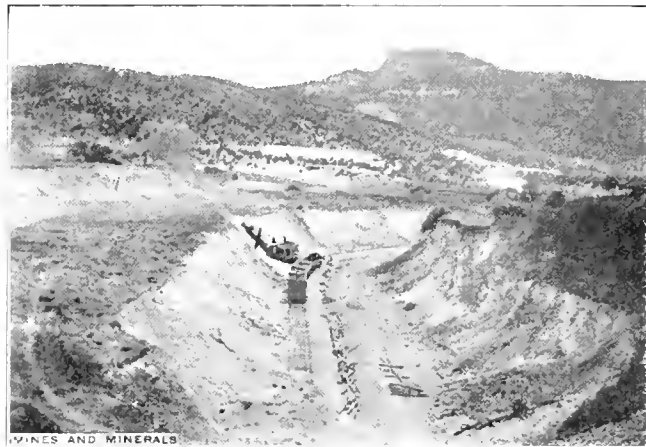

ANOTHER SECTION OF STEAM SHOVEL PIT

follows: Spur tracks from the standard-gauge railroad come in along the west side of the plant. The cars of ore loaded at the steam-shovel pits are hauled from the mines and run up an elevated spur on the west side of the crusher building, where there are storage bins into which the ore is dumped from hopper-bottom cars.

To the east of the crusher building is the concentrating mill. To the south of it is the central power plant.

The outline of the course of the ore in its passage through the plant and its treatment is briefly as follows: From the bins at the crusher building the ore is fed to a Gates rock breaker and reduced to about 1½ inches in size. It then passes to rolls for further reduction and is finally carried on a long inclined elevator belt and stored in six cylindrical steel ore bins along the west side of the concentrating mill. From the bins the ore is distributed to the plant in a regulated flow. The separation and concentration are effected with jigs, Chilian mills, classifying and settling cones, and vanners. The Chilian mills are just east of the ore bins, on an upper floor, and on a line parallel with the bins. The jigs are on a lower floor. The mill from here on is a lower structure with a slight descending grade, with an upper floor of classifying and settling cones and a lower floor of vanners. Some of the vanners are also on an upper floor.

The ore, after being crushed, is sized and the larger sizes are treated on jigs, effecting a separation resulting in concentrate, middling, and tailing. The concentrate contains sulphides and native copper. The middling requires further crushing to liberate the mineral mixed with gangue and is then retreated with other small sizes from graded sizing. The tailing is barren or sufficiently lean to reject, and thus a large proportion of waste in large sizes is got rid of at the start. This reduces the amount of fine crushing that would otherwise be required and tends to economy and a minimum production of slime.

The finer crushing is accomplished in the Chilian mills. The discharge from these passes to classifying cones, and their classified products are treated on vanners.

The final product of the vanners is concentrate and tailing. The concentrate is finally loaded on railroad cars for shipment and the tailing goes to the dump.

All overflow water carrying slime too fine to settle otherwise is conducted to a large concrete rectangular reservoir to

the north of the plant where it is allowed to settle sufficiently before reusing in the plant.

The power plant, built in three sections, has been found to be of sufficient capacity to operate a mill of five sections. This consists of eight boilers, three 5,000-horsepower engines, and dynamos.

A supply of water is obtained from three sources: Santa



STEAM SHOVEL DIGGING ORE AFTER STRIPPING

Rita, Whitewater, and Apache Tajo. The length of water lines is 4 miles.

Should additional water be required, possibly a gravity supply can be obtained from the Upper Gila River, about 50 miles distant, or from the Mimbres River.

The ore that can be mined by steam shovels will supply the mill for many years. The ore horizon dips under portions of the property so that it will have to be attacked by deeper mining. Just at present the main developments are for mining large tonnage by steam shovels.

One mine, the Wild Cat, is being worked and affording some very good ore. This is to the southwest of the steam-shovel pits.

The climate is very favorable for steam-shovel work, as very little snow falls in the winter to obstruct work—as it does at times in the steam-shovel pits of the Utah Copper Co., at Bingham, Utah, and the Nevada Consolidated Copper Co.'s pits at Ely, Nev.

來 來

Brass and Bronze Alloys

The following mixtures are advocated in the United States Government specifications issued by the Bureau of Steam Engineering. The composition must be made of such materials as will give the required chemical analysis. Scrap will not be used except such as may result from the process of manufacture of articles of similar composition.

Commercial Brass.—Copper, 64-68 per cent.; zinc, 32-34 per cent.; iron, 2 per cent. (maximum); lead, 3 per cent. (maximum).

*Muntz Metal**.—Copper, 59-62 per cent.; zinc, 39-41 per cent.; lead, .6 per cent. (maximum).

Brazing Metal.—Copper, 84-86 per cent.; zinc, 14-16 per cent.; iron, .09 per cent. (maximum); lead, .3 per cent. (maximum).

Gia Bronze.—Copper, 87-89 per cent.; tin, 9-11 per cent.; iron, 1-3 per cent.; iron, .06 per cent. (maximum); lead, .2 per cent. (maximum).

Low's Bronze.—Copper, 82-84 per cent.; tin, 12½-14½ per cent.; zinc, 2½-4½ per cent.; iron, .06 per cent. (maximum); lead, 1 per cent. (maximum).

Valle Bronze.—Copper, 87 per cent.; tin, 7 per cent.; zinc, 6

* No mention is made of the iron content

per cent.; iron, .06 per cent. (maximum); lead, 1 per cent. (maximum).

Manganese Bronze.—Copper, 57-60 per cent.; zinc, 37-40 per cent.; tin, .75 per cent.; iron, 1 per cent. (maximum); aluminum, .5 per cent. (maximum); manganese, .3 per cent. (maximum).

Monel Metal Castings.—Nickel, 60 per cent. (minimum); copper, 33 per cent.; iron, 6½ per cent.; aluminum, ½ per cent.

Cast Naval Brass.—Copper, 59-63 per cent.; zinc, 35½-40½ per cent.; tin, ½-1½ per cent.; iron, .06 per cent. (maximum); lead, .9 per cent. (maximum).

Phosphor Bronze.—Copper, 80-90 per cent.; tin, 6-8 per cent.; zinc, 2-14 per cent.; phosphorus, .30 per cent.; iron, .06 per cent. (maximum); lead, .2 per cent. (maximum).

Screw Pipe Fittings of Brass.—Copper, 77-80 per cent.; zinc, 13-19 per cent.; tin, 4 per cent.; iron, .10 per cent. (maximum); lead, 3 per cent. (maximum).

Metallic Nickel.—Nickel, 97 per cent. (minimum).

Thrust Rings.—Copper, 82-84 per cent.; tin, 12½-14½ per cent.; lead, 2½-4½ per cent.

Monel Metal Ingots.—Nickel, 60 per cent. (minimum); copper, 38 per cent.; manganese, 2 per cent.

With small amounts of other ingredients not injurious to casting qualities, or detrimental to strength or non-corrosive properties.

來 來

Parting Tray

A parting tray that will prove more satisfactory than any that can be purchased can be made from a piece of ¼-inch sheet iron 8 in. × 16 in. The tray proper is 8 in. × 9½ in. and contains 30 holes 1 inch in diameter and spaced ½ inch. The legs are made from rivets through the corners but can be made by simply turning down the corners of the plate. The handle is 6½ inches long and 2 inches wide. The tray is designed to hold 30 porcelain crucibles 1½ inches in diameter, which is the size generally used for parting.

In use the tray is placed at the left of the silver balance and the number of cups needed placed in it. As the buttons are weighed they are placed in their respective cups. When all are weighed the tray is carried to the laboratory where the nitric acid is added to the cups and the whole placed on a hot plate. When the buttons are parted the tray is removed and the gold sponges washed in rotation.

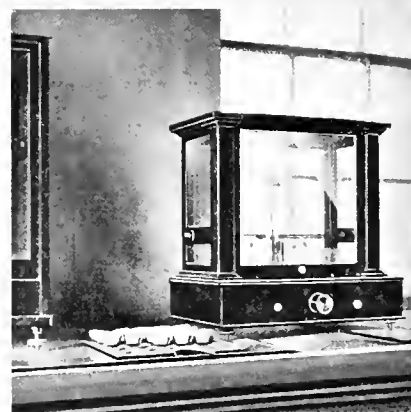

PARTING TRAY

The tray containing the washed gold sponge is now replaced on the hot plates and the assays allowed to dry, after which the tray is carried to the furnace and placed for a few minutes in the hot muffle to anneal the golds. It is then placed on an asbestos board at the left of the gold balance and in a few minutes the assays will be cool enough to weigh. It will readily be seen that in handling the crucibles as a unit much time is saved; the only time they are handled separately being when they are washed.

Zinc Mines of Southern Nevada

A Description of the Yellow Pine District, the Ores, and the Costs of Mining and Shipping

*By Douglas White**

[The following paper was read by Douglas White at the Goldfield meeting of the American Mining Congress. The late E. R. Buckley visited this district after the meeting and wrote the editor of MINES AND MINERALS as follows: "I took no notes, giving facts and figures. Therefore, my chief stock in trade is 'general impressions.' These I do not have the capacity to place in print." EDITOR.]

I remember distinctly a heated argument between two railroad men which left its impression upon me. The parties to this argument were an engineer, lately graduated from one of America's greatest educational institutions, and a hardy foreman, who had worked his way, as the saying is, "from the spike up." With many a strenuous expression, each of these two advanced his individual ideas upon the means to be used for the handling of an important emergency work upon a line tied up by storms, until finally the foreman closed the controversy with the following pointed declaration: "You may be all right, Mr. ———, from the standpoint of what you learned in those books of yours. I never picked up my railroading from looking down an ink bottle, but I have had some experience in handling landslides and washouts, and it has come right when the land was a slipping and the water tearing the grade from under the ties. Now, if you want to get this line open you will have to turn your back on your cube roots, equations of resistance and those blueprint pictures your draftsmen make out, and let me get a train load of Micks out there to meet the conditions." The engineer gave way and in 12 hours the line was in operation. Incidentally the foreman who had not learned his business while looking down an ink bottle, is today one of the most successful operating officials in the West.

Now, I am not attempting to prove that the lack of education is by any means a stepping-stone to success, but simply to lead to the point that I, like the foreman, have not learned what I know about the zinc possibilities of Southern Nevada while looking down an ink bottle, but have picked up a primer knowledge of what is destined to become a most important mineral district from an actual contact with the district itself and the several mines which go to make up its aggregate of immense future wealth.

It is not my intention to bore you with technical details or columns of figures, but to tell you as plainly as I can of another section of Nevada which is rapidly adding to the mineral wealth of a state which has, for four decades, continued to astonish the world with her mineral surprises. This section is comprised within the borders of what is known as the Yellow Pine mining district and lies almost at the southern angle of the state, where the lines of Nevada, California, and Arizona have a meeting point. To be exact, the district lies over against the eastern line of California, with its center about 40 miles southwest of Las Vegas, and about 300 miles northeast of Los Angeles, being bordered on the west by the Nevada-California line and on the east by the right of way of the San Pedro, Los Angeles & Salt Lake Railroad. The district, like a great blanket 25 miles long by 8 to 20 miles wide, is spread out lengthwise over the southwestern end of the Charleston range of mountains. The elevation of the district ranges from 2,700 to 8,000 feet and it is upon the slopes and in the great washes of the bleak hills that the outcroppings are found, which lead the miner to the rich deposits underneath.

The geological formation is briefly described by stating that the Permian limestones have intruded and overlapped the Mesozoic. The Carboniferous formation covers the entire field. The metallic deposition is in the crystallized limestones and usually accompanied upon the hanging wall with porphyritic dikes. The ore occurrences are zinc replacements in the limestone, in chambers of

unknown and varying sizes, with well-defined bedding planes and irregular walls. No development to date shows the full ore horizons.

The Yellow Pine district is by no means a new factor in Nevada's mineral wealth, in fact it ranks as one of the pioneers among the mineral-producing sections of the Pacific slope. Long before there was a Comstock, and nearly half a century before Tonopah and Goldfield occupied places on Nevada's map, Mormon pioneers in trekking southward from Utah into California discovered a great lead deposit upon the slopes of what was originally known as Mt. Olcott, but more recently christened Potosi Mountain, which stands as the northern landmark of the Yellow Pine district. From this deposit, for years known as the Mormon mine, was taken ore so pure that it could be immediately molded into bullets, and I have had the pleasure of listening to the reminiscences of President Joseph Smith, now the executive head of the Mormon Church, in which he related how, when but a boy, he accompanied a party who visited these old diggings for the purpose of securing metal from which to mold the bullets used by the Saints in hunting and in the defense of their homes. As this ore from the Mormon mine carried a high percentage of silver, those Utah pioneers undoubtedly used the most expensive ammunition ever fired from a rifle. There is, however, a story regarding one family of early settlers who lived upon the western edge of the Yellow Pine district, who procured their bullets from the same or a like source. Upon their raids against either human or animal foes, these desert rangers left their marks in the shape of silver bullets more pure than the coins which are now turned out from Uncle Sam's mints.

This opening of the Mormon mine was really the beginning of the development of the Yellow Pine, and during the next 40 years it was followed by the opening of several prosperous properties noted for their production of lead plentifully mixed with silver. Some gold properties were developed, which proved valuable, and when it is considered that every pound of ore then mined was hauled for miles over the desert to a shipping point, it must certainly be conceded that the Yellow Pine has a place in the mining history of the state.

During all these years the miners of the Yellow Pine were annoyed by constantly occurring deposits of a greyish white substance, which, in certain places, became so plentiful that it was commonly known as country rock. It was not until about 4 years ago that an expert, visiting this section in the interests of a smelting company, picked up some of this grey rock from one of the many dumps and immediately pronounced it zinc carbonate of a high grade. This discovery is attributed to Mr. Connie Brown, of New Mexico, but whether or not he is the rightful zinc Columbus of Nevada I am unable to state.

Among the operators of the Yellow Pine there was an immediate zinc excitement, and several cars were shipped to Kansas smelters. Owing to the absolute lack of knowledge of zinc these shipments proved failures, and the Yellow Pine again settled back to its modest output of lead, silver, and gold, and the development of several fairly promising copper properties.

Among the operating companies was the Yellow Pine Mining Co., owning a large group of silver-lead properties upon the eastern slope of the range. Here, too, zinc showed in great quantities, and, after several careful experiments, shipments were begun which have continued with profits varying only as the price of spelter rose or fell. These shipments attracted the attention of mining men and ore buyers, and several properties in the district were bonded. Again the lack of zinc knowledge proved the downfall of this new boom, yet the Yellow Pine Co. continued to develop its great bodies of ore and to ship just enough of its product to show that there was high-grade zinc in the Yellow Pine district if it was properly mined.

Outside of the product marketed by the Yellow Pine Co., zinc became a dead issue until one of Nevada's well-known mining pioneers, Jack McDonald, purchased one of the principal prospects and shipped therefrom 14 cars which averaged 42½ per cent. zinc. McDonald bonded this property to Montana people who, after a few weeks' work defaulted in their payments and asserted that

* Editor Arrowhead.

the mine resembled a melon which had been gouged and nothing left save the skin. I am seized with an unrestrainable temptation to refer to the little story with which I began this paper and state that, in the hands of its present owners, this property has, in the last 9 months, under the direction of competent zinc operators, shipped to Kansas smelters over 3,000,000 pounds of high-grade zinc ore taken from its workings in the course of active development.

The shipments have attracted the attention of some of the shrewdest buyers of zinc ores, and by means of their investigations of the district, there has been brought in capital which is now being used to properly develop a number of the most promising prospects. Several of these are already shipping, and others are simply opening up their ore bodies.

It is ridiculously odd how the opinion of experts will differ regarding mineral prospects. I was amazed at a report filed upon the Yellow Pine district by an expert of national repute, who, after a thorough examination, pronounced it absolutely worthless from a zinc standpoint, and his negative report was bereft of its sting by the story of an incident in which this same mining engineer played an important part. It seems really good enough to find a place here. Some years ago, one of California's mother-lode properties was bargained for by an eastern syndicate, who sent not one, but five young engineers to "expert" the mine. The mine was owned by an old-time Californian and was well equipped with mill, etc. There was plenty of development work done and, in fact, the mine was merrily operating when the five experts arrived to pass upon its value. They requested that work should stop while they looked the property over, and occupied the little assay office in making their tests. For nearly a week they toiled away taking samples and making tests. Finally, they announced that they were finished, and the owner, calling their spokesman aside, asked in confidence as to whether their report would be favorable or the reverse. The old-timer had become quite a favorite with the five youngsters during their stay, and after much beating about the bush, the spokesman released the information that they, much to their sorrow, would be compelled to report that the mine did not come up to the proper standard. "Well," replied the grizzled owner, "I suppose you have done the best you could, but I don't feel so mighty sorry about it, for I really think my price on the mine was all-fired low, so we will just take a drink, eat dinner, and then I'll drive you down to catch the East-bound overland."

"But," said the young engineer, "we are not going East, we are going to San Francisco."

"Going to 'Frisco, the hell you are!" replied the owner.

"Why, what difference will that make?" queried the engineer.

"You see it's this way," explained the old-timer. "If you go to 'Frisco, being mining men, you'll want to visit the mint."

"I don't know as we shall," said the engineer, "but I do not see what difference it will make to you if we should."

"Well," said the old man, "if it ain't important to you I really wish you would help me out by keeping away from the mint when you get down to the bay."

"We will do that if you say so," replied the youngster, "but I really would like to know why."

"Well, I'll tell you," answered the owner, "you have reported that my mine ain't got no gold to speak of, but I have been taking out some sort of stuff and shipping it down to the mint. Now, them fellers are fools enough to think it's gold and are paying me about \$15,000 a month for it, but if they should hear your report, they might get wise and that would spile my game."

It must not, however, be inferred that this single instance of adverse expert opinion, has been followed by a like opinion from other and equally prominent experts who have visited the Yellow Pine district. Since November 1, 1908, some of the men who are in all America the best posted upon zinc mines and zinc ores, have made examinations extending over portions, and in some instances all, of the district, and the unanimity of opinion expressed by these gentlemen is best illustrated by the fact that the visit of one of them has failed to produce a negotiation for property,

several of which have been carried to a successful conclusion, and have been the means of starting development work upon several different properties in the district.

To speak definitely of some of the various mines which have already shown exceptional values, it is only necessary to refer to such properties as the Potosi, which is a modern and fully equipped group of claims which were the original mine of the Yellow Pine district, first known as "The Old Mormon mine." The Potosi has been an intermittent shipper and, like other properties in the district, has suffered from a lack of knowledge of the peculiar ores which it furnishes. Another detriment under which the Potosi has suffered is its distance from the railway, which detriment undoubtedly will be ultimately removed by the construction of a spur from the main line of the San Pedro, Los Angeles & Salt Lake Railroad, and when this become a reality the quarter-million tons of ore now blocked out in these properties will be rendered available for shipment to the Kansas smelters at a more than reasonable profit.

Another property which has been extensively worked and which has been a heavy producer in lead ores, is the Green Monster, which forms a portion of the famous Hearst estate. This mine was, owing to a lack of transportation facilities, closed down before the coming of the railroad, and before the operators of the Yellow Pine district knew that they were throwing high-grade zinc ore over the dumps. In the Green Monster there are at present a great many thousand tons of ore, which will run upwards of 40 per cent. zinc and 25 per cent. lead.

The mines of the Yellow Pine Mining Co., already mentioned in this paper, have an immense body of ore blocked out and are shipping enough zinc and lead to meet all their extensive development and equipment expenses, leaving a good margin of profit for each month's operation.

One of the peculiarly located properties of the Yellow Pine district is that known as the "Bonanza Hill." This is a patented property in which the development work has proven a vast body of lead and zinc ores, all of its five claims being well opened by shafts, drifts, and tunnels. Like other properties in the district showing both lead and zinc, the ores of the Bonanza Hill require no milling, except to separate the zinc and lead, which up to the present time has been done by hand picking. An advantage which this property possesses is that it lies directly alongside of what is known as the Mesquite Valley, where ample water for all milling purposes can be secured by sinking not to exceed 50 feet below the surface. This water supply can be obtained at a distance of less than 1 mile from the property.

The Monte Cristo group of mines, which includes the original Monte Cristo and a portion of what was originally known as the Evening Star group, is one of the most advantageously located properties of the district. This advantage of location has been made use of by the Monte Cristo's present owners, and during the last 10 months, while development work on the property has been carried on, nearly 100 cars of high-grade ore have gone forward from the Monte Cristo to Kansas smelters.

Unlike the majority of the properties in the Yellow Pine district, the Monte Cristo ores have, up to the present time, carried practically no lead, there being present in the ores already mined upward of 40 per cent. metallic content of zinc, with from 6 to 15 ounces of silver per ton.

The Monte Cristo has labored under a special advantage, owing to the fact that one of its principal officials is an expert zinc operator—in fact, the first one of his class to enter actively into the development of the Yellow Pine district. Backed by this special knowledge of zinc, the Monte Cristo has taken the lead both in active development and shipping. There are dozens of other promising mines which have passed beyond the prospect stage, and are simply waiting the arrival of competent ability and capital before they can be developed into paying propositions. Among these may be mentioned the Green Monster, the Mobile, the Mountain Top, the Sultan, the Gila Monster, the Frederick Ward, and several others offering more or less possibilities.

From the various properties mentioned it is a conservative estimate that the Yellow Pine district can produce upwards of 1,000,000 tons of zinc ores, the greater portion of them carrying upwards of 40 per cent. zinc and 25 per cent. lead.

Two events of recent date have tended to add to the importance of this district from a zinc-producing standpoint. The principal of these is the advance in tariff, which has practically prohibited the entry into the United States of zinc carbonate ores from the Republic of Mexico, which carbonate ores were in reality the only active competitors of the Yellow Pine.

The second of these events has been the reduction in freight on zinc ores from various points in Nevada to the smelting centers in Kansas, recently granted through the influence of the San Pedro, Los Angeles & Salt Lake Railroad, which will cause a saving of from \$2 to \$3 on freight on all high-grade zinc ores forwarded to these smelting points. This difference in freight alone would cause a reasonable profit upon the tonnage which can be produced by several of the greater properties in the Yellow Pine district, and will certainly serve to render profitable some of the properties which have not been in operation owing to the excessive wagon haul between their locations and the shipping point.

One of the first questions which will be raised by the conservative investor will be the cost of placing these ores from the Yellow Pine district at the Kansas smelter points. Based upon actual experience, I can give the following figures:

Cost of mining.....	\$2 00	
Cost of wagon haul.....	2 50	
Freight.....	8 00	\$12 50
<hr/>		
Value of product, estimated as carrying 40 per cent. metallic content, f. o. b. Kansas smelting points.....	26 60	
Net value per ton of ore mined.....		\$14 10

When it is considered that many of the stopes carry a metallic content running as high as 44 per cent. to 49 per cent., it will be seen that the net returns will run from \$18 to \$23.

In some of the cases where the wagon haul extends beyond the summit of the Charleston range, the cost of hauling would be increased to \$3.50 or \$4 per ton, but several of the properties so situated are possessed of a sufficient tonnage of high-grade ore to render this excessive cost of hauling unimportant under the present market conditions of zinc.

I might go on and enter into a comparison of the net returns between a ton of ore raised at Joplin and the ores produced by the Yellow Pine, but as there is not and cannot be any direct competition between the two districts, owing to the difference in the quality and value of their ores, such a comparison would be redundant.

One of the advantages which particularly commends the ores of the Yellow Pine to the shrewd ore buyers who are constantly seeking new products for their smelters, is that it is a calamine, requiring no milling; free from sulphur, hence no roasting; and is the only grade of ore in the West that can be transformed into a zinc oxide approaching 100 per cent. in purity.

I would be speaking fairly within bounds if I were to prophesy that within a period which can be computed in months, there will be available for the smelters not less than 200 tons per day of high-grade zinc carbonate ore from the Yellow Pine district. In these figures I do not include any metal save zinc. Consequently it is only a question of a reasonable length of time before the necessity of a smelter within a reasonable distance from this district will become apparent to investors. Already there has been more than a well-defined rumor of a plant of this nature to be located at Las Vegas, less than 40 miles away from the center of this district. In the plans of this plant will be included means for reduction not alone of zinc, but also of lead, copper, gold, and silver.

With the present market conditions and the constantly increasing demand for spelter, there is no reason to look forward for anything but success in the various properties of the Yellow Pine district which are already producing ore or are undergoing development toward the shipping point. Could an individual or a corporation own a property which clearly showed the presence of from 50,000 to 100,000 tons which would pay a net profit of from \$13

to \$23 f. o. b. at the smelter points, how many congratulations would be extended to them, and how fast they would have to present a negative to prospective purchasers. But being zinc, and zinc which is produced in a remote corner of the United States, laden with a heavy expense for hauling and freight, it has required the most emphatic success to attract the attention of buyers and operators to the Yellow Pine district. It seems that the attention which has been drawn is but the beginning of an era which will place Southern Nevada among the greatest zinc-producing sections of the country, and add one more to the grand aggregate of producing districts of the State.

There are two points not already covered, to which attention should be drawn. They both arise from the fact that Southern Nevada has from its first discovery been termed a desolate desert waste, scorched by a fiery climate and absolutely devoid of water. In the first place, to those who know and realize the conditions, the great Southwestern Desert is rapidly passing into history. The climatic conditions are such that no day in summer carries a sufficient excess of heat to render it impossible for men to work, while on the other hand, the winters are so mild as to be almost devoid of frost. This renders it possible for a continuous operation of properties during the entire 365 days of the year.

Then comes the question of water. In this regard, I wish to call attention to the fact that through this southern desert the railroads manipulated by Senator W. A. Clark have within the last 5 years opened up nearly 500 miles of absolutely new construction. Now you are all aware that a steam railroad requires water, and requires it at fixed points along the line. In these 500 miles of construction, water was sunk for, not at points where there were signs of its existence, but at points where it was necessary for it to be produced in order to meet the railroad's demands, and in all the wells so sunk there were but three failures, and in one instance of these three there was discovered a plentiful supply of water, but its quality was not such as to make it available for steaming purposes. Throughout the whole length of the Yellow Pine district there exist today flowing springs of remarkably pure water and in the very center of the district, at the town of Good Springs, there lies an area of water-producing land whose capacity has never been even tested by the many wells which have been sunk by the residents in that section.

Along the west border of the district, in the Mesquite Valley, there is an area of thousands of acres upon any one of which water can be secured by sinking not to exceed 50 feet below the surface. This condition is being rapidly taken advantage of at present by settlers who have within the last year taken up large areas of the Mesquite Valley bottom land, and by means of pumps are producing water with which to irrigate their ranches.

Sooner or later the question of milling is going to be a factor, and when that question arises there will be water and to spare for all necessary operations.

Another factor contributing toward the success of the Yellow Pine district is its proximity to transportation facilities. As was stated earlier in this article, the lines of the San Pedro, Los Angeles & Salt Lake Railroad, known as the "Salt Lake Route," follow along the entire length of the eastern border of the district, the principal shipping point being the station at Jean; and it is only a question of time when the necessity will arise for the construction of various spurs or tributary feeders from the main line of this railway to the central points from which the ore of the district may be cheaply and rapidly handled in transit to the smelters.

Thus it may be seen that in addition to its phenomenal deposits of zinc allied to those of its other metals, the Yellow Pine district of Southern Nevada possesses climatic conditions in every way conducive to its success; a water supply sufficient to meet every possible demand, and transportation facilities which give it reasonable, cheap, and rapid connection with those points where its ores can be transferred into metals by the various smelters. Under these conditions it is not a foolish prophecy to point out for this district a success, which in its very beginning has attracted the attention of some of the greatest mining men of America.

Block Caving and Substopping.

Systems Employed at Tobin Mine, Mich., Showing Adaptation to the Special Conditions Met

The following paper entitled "Block Caving and Substoping System at the Tobin Mine, Crystal Falls, Mich.," was presented by Fred C. Roberts, Crystal Falls, Mich., at the 1911 meeting of the Lake Superior Mining Institute:

The systems of mining at the Tobin mine were adopted after the

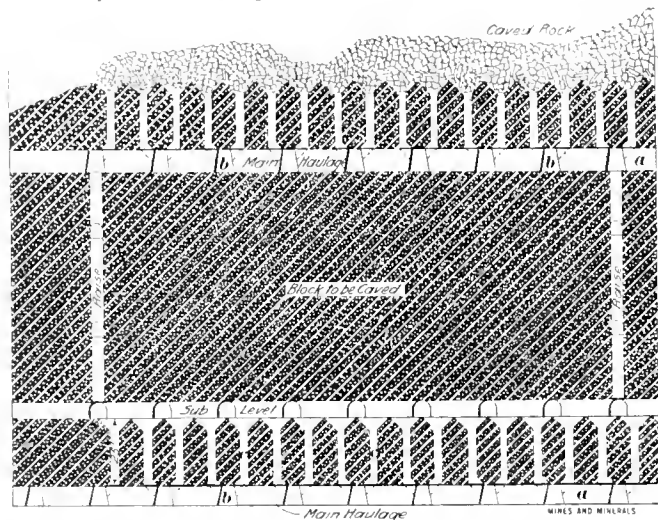

FIG. 1. LONGITUDINAL SECTION, BLOCK CAVING SYSTEM

trial of several systems, each of which proved more or less unsuitable to the peculiar nature of the ground to be mined.

Underhand stoping was tried, but soon discontinued on account of the continual falling of ground. Back stoping was next tried, but the danger from falling ground was still too great. Substopping was the third system tried, and in some parts of the mine where

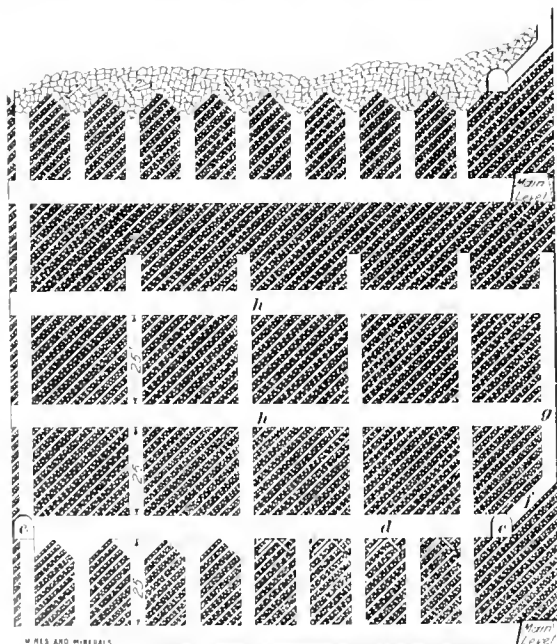

FIG. 2. CROSS-SECTION OF END OF BLOCK

the ore body is too narrow or too firm to be mined by the block-caving system it is still used. Block caving, the next system attempted, proved so well adapted to the physical conditions of the ore that it has been adopted as the principal method of mining.

The levels at the Tobin mine are 125 feet from floor to floor, and the main haulage level, *a* Fig. 1, follows very closely the hanging wall.

In the block to be mined by caving, parallel cross-cuts *b* 24 feet from center to center, are driven from the main level as nearly at right angles as may be, to the foot-wall, and are connected at the foot-wall side by a small drift for ventilating purposes. Throughout the length of these cross-cuts, chute raises *c* are put up alternately on the right and left sides at intervals of 15 feet, to the sublevel *d* as shown in Figs. 1 and 2.

The sublevel *d* is opened 25 feet above the main level and a heading *e* parallel with and about 15 feet from the hanging wall, the entire length of the block to be mined. Cross-cuts *h*, Fig. 2, are driven to the foot-wall from this sublevel heading directly above the cross-cuts on the main level. Opposite each cross-cut

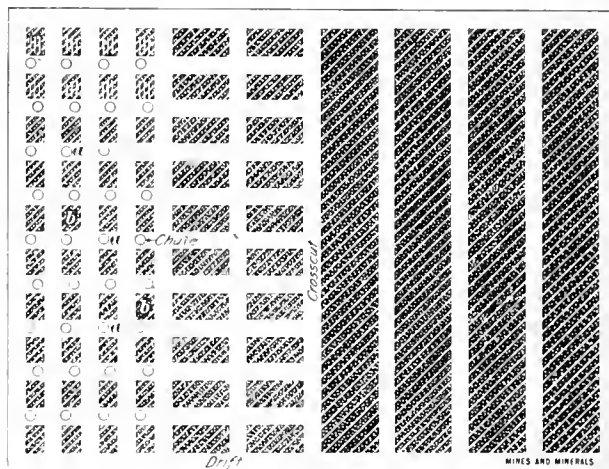

FIG. 3. FLOOR PLAN OF SUB

on the sublevel, as shown in Fig. 2, a raise *f* inclined about 45 degrees is put up from the subdrift to the hanging wall, the object being to leave an additional thickness of ore above the main haulage level. The cross-cuts on the sublevel are connected every 15 feet by drifts over the line of chutes *a* leaving small pillars *b* of about 10 feet by 16 feet, as shown in Fig. 3. It is sometimes necessary to cross-cut these small pillars again, depending upon the nature of the ground. A heading is also driven along the foot-wall connecting all the cross-cuts.

After the pillars have been reduced to a suitable size, they are drilled with a sufficient number of holes so that they may be all blasted at once. The pillars furthest from the manway being drilled first. Holes are also drilled around the tops of the chute raises, Fig. 2, and blasted, making the raises funnel shaped at the top. At the ends of the block to be caved, it is necessary to weaken the ground so that it will cave square with the pillar. Raises *g* are put up from the end cross-cuts at varying intervals, depending on the nature of the ground. These raises are connected by two cross-cuts *h*, 25 and 50 feet, respectively, above the sublevel as shown in Fig. 2.

After all the necessary raising, drifting, and cross-cutting have been completed, the holes in the pillars of the sublevel are all blasted at once, undercutting the entire block, which settles down on the back of the level below. The ends of the block not being entirely cut off from the pillar, the ore does not drop down in one solid block, but breaks up in settling and comes down in such shape that it can be handled through the funnel-shaped chute raises with only occasional blasting of masses that lodge in the chutes. The caved ore is drawn uniformly throughout the level so that it will settle down evenly, and this keeps the caved rock from the old level above from getting mixed in with the ore. This method of handling the block-caving system shown in Fig. 2 is so far as known original with us.

Substopping is followed where caving is not practical, at the narrow ends of the ore body, and in pockets and smaller deposits that are sometimes found separated from the main body. Conditions vary so in these cases, that they have to be met in different ways. The nature of the ground and the dimensions of the ore

body have to be taken into consideration in each case, and the method of mining adapted to it.

The usual method of working these places is to drive a heading on the main level the entire length of the ore body and determine its width by cross-cuts. Chute raises are put up at intervals of about 15 feet. From a raise, at the end of the ore nearest the shaft, a sublevel is opened 14 feet above the main level. This sublevel consists of a drift the length of the ore and connected at the far end with a raise from the main level. Second, third, and fourth subs are opened in a similar manner above the first, 20 feet being the usual distance from the back of one sublevel to the floor of the next above. The raise at the far end of the ore is carried through to the upper sub.

All preliminary development work being completed, stoping is begun at the far end of the ore on the lower sublevel. Upper and underhand holes are drilled and blasted around the raise which connects all the subs at the far end. The ore thus broken falls into the chutes at the bottom of the raise. This is repeated until the lower sub is drawn back 12 or 15 feet, as shown in Fig. 4, when the miners on the second sub begin stoping in a similar manner to that done on the first sub. The second sub having been drawn back to a safe distance, the third substop is begun. In this way each gang of miners is always working under solid ground and far enough back

upward to surface or to the bottom of another large piece, making a devious narrow path for the material to pass through. The overburden of sand or other waste material will appear at the bottom before any ore comes in from the sides. The gathering in from the sides always begins at the top. But, if all the chutes are drawn evenly, the whole mass of ore will settle evenly, and the overburden will follow without mixing with the ore.

采 采

Mining Society and Educational Notes

Kentucky Mining Institute will hold the next meeting at Lexington, on June 10, 1912. The committee on program and entertainment consists of Messrs. Hywel Davies, P. V. Cole, and H. D. Easton. It is probable that an excursion will be arranged and that the meeting will last two or three days. The December meeting was so successful a large attendance is expected. For particulars address Prof. H. D. Easton, chairman, and for membership applications address T. J. Barr, secretary, both of Lexington, Ky.

Nicholas Murray Butler, president of Columbia University, has issued a circular addressed to the principals of college pre-

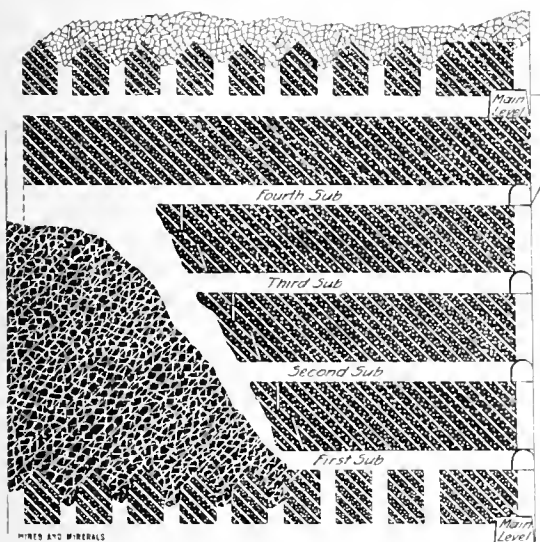

FIG. 4. LONGITUDINAL SECTION OF SUBSTOPPING

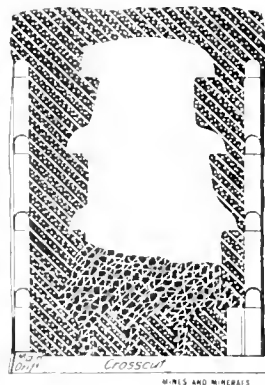

FIG. 5. CROSS-SECTION OF STOPE

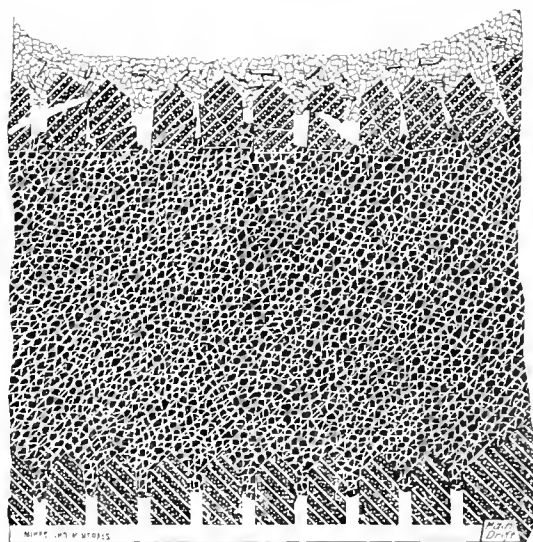

FIG. 6. CROSS-SECTION OF CAVED BLOCK

to escape falling ground from the stopes above. Fig. 6 shows a cross-section of a caved block.

The width of a stope that can be carried this way depends upon the nature of the ground. In the Dunn and Great Western mines where the ground was exceptionally firm, with a strong capping above, stopes were worked out 80 feet wide. The first stope was carried 30 feet wide through the middle of the ore, beginning at the far end and drawing back. Benches as in Fig. 5 were then cut at each sublevel the entire length of the ore pillar of each side of the stope. These benches were cut into the pillar far enough to protect the men from falling ground from the others working above. Beginning at the far end and drawing back, these benches were stoped out by upper and underhand holes, the broken ore falling into the open stope. The process was repeated to remove the remaining ore in the pillars.

In the discussion, Prof. F. W. Speer stated that Mr. Roberts' reference to the necessity of drawing off the ore uniformly, is a consideration of the highest importance in the block-caving method; for, if ore should be drawn from one chute continuously without drawing any from the surrounding chutes, a vertical pipe of material with a diameter about equal to that of the bottom of the chute would move downward all the way from the surface. If a large unbroken block of ore obstructs the vertical passage, a hole will work itself out to one side, forming a new chute to continue its way

paratory schools, in which he calls attention to the raised requirements of admission to the Schools of Mines, Engineering, and Chemistry. After July 1, 1914, candidates for admission to these schools will be required to present evidence of such preliminary general education as can ordinarily be had in a college course of 3 years. This makes the course 6 years.

Summer School in Assaying.—Prof. E. J. Hall, who has had charge of the Assay Department at Columbia University, New York City, for a number of years, will have charge of a 6 weeks summer course in assaying. Students and young assayers who desire to increase their knowledge in assaying will find this an excellent opportunity. The enforced idleness at many mines in the Northwest in winter led to the opening of a winter auxiliary assay course in Washington University, and this summer school at Columbia should appeal to those who are spending vacations in the vicinity of New York City.

Sugar Creek Mining Society takes its name from the Sugar Creek coal mining district, near Athens, Ohio. Its purpose is to disseminate knowledge pertaining to coal mining, discuss improvements, deal with matters which pertain to first-aid work, rescue apparatus and work, and stimulate interest generally in the prevention of accidents in and about mines.

The International Society of Mining Accountants was organized in March, 1912, with W. H. Charlton, 46 Hooker Ave.,

Detroit, Mich., as secretary. The objects of this society are to promote the science of accounting and allied subjects connected with the production of the useful minerals and metals on the American continents, by means of an annual meeting, with the reading of practical papers on accounting, etc., and the publication of the proceedings in an annual volume.

Mr. Waldemar Lindgren, chief of the Division of Mineral Resources, United States Geological Survey, delivered an illustrated lecture on "California Gravels" to the Mining Society of Sheffield Scientific School in April.

The senior and junior students in the Department of Mining Engineering of the University of Illinois have recently visited the Illinois Steel Co.'s plant at Joliet, the mines, zinc works, and cement plants in the La Salle district, of Illinois, and a number of manufacturing plants in Chicago, where mining machinery is made, also the accounting offices of a number of the larger mining companies having headquarters in Chicago.

The College of Mines of the University of Washington made its spring excursion for mine inspection to Texada Island, March 28 to April 6. The party consisted of senior and junior students accompanied by Dean Milnor Roberts and Prof. Joseph Daniels. The objects of the trip were to study the deposits of iron, copper, gold, and limestone, and to inspect the lime kilns, oil-burning smeltery, and mining equipment of the region.

C. W. Henderson, in charge of the United States Geological Survey work in Colorado, delivered an address, April 13, before the Colorado Scientific Society on the "Relation of the United States Geological Survey to the Mining and Metallurgical Industry."

George E. Collins, president of the Colorado Scientific Society, and A. D. Parker, part owner of the Florence mine, at Goldfield, Nev., delivered toasts at a banquet tendered by the regents of the University of Colorado to the representative technical organizations of Denver, at the Boulderado Hotel, Boulder, Colo., April 20.

A Durable Shaking Screen

By Roy Reddie

The old, reliable, revolving screen, or trommel, is probably the easiest running device, the least costly in repairs, and the one least likely to transmit vibration to the frame of a mill building, of any screening device that can be installed. It requires some considerable head room, however, and on this account many mill men are ready to concede the advantages to be gained from the use of an open-top, comparatively flat screen of the reciprocating type screening and delivering its load with slight loss of head.

The old cam-driven, bumping, or impact, screens made such a noise and set up such a vibration when in action, that mill men became prejudiced against them. The eccentric-driven shaking screen has to some extent shared in the condemnation showered upon its noisy relative. After a somewhat exasperating experience with shaking screens of the all-metal type defying the efforts of the repair gang to maintain tight rivets and bolts for a longer period than a few days at a time, the writer designed the screen illustrated, with a view of overcoming that trouble. This has given entire satisfaction both for screening efficiency and low repair bills, for a period extending over 2 years.

It can be readily built by the mill carpenter and the mine blacksmith. As shown in Fig. 1, it consists of a wooden frame to which the angle irons—carrying the punched plate screen and front apron plate, together with the undersize pan beneath, are bolted. The frame is hung between two hangers in front and two rocker-arms supporting the back end. It is driven by two eccentrics of the heavy adjustable jig type, the 1 3/4-inch plunger rods of which are forged into heavy eyes on the outer ends and then shrunk on to a cross-shaft, or gudgeon, bolted to the bottom of the frame by means of two hardwood boxes; the gudgeon should be a snug fit in these boxes as the movement is slight; the shaft collars should be placed on the inside of frame.

This screen handles the discharge from a 20-foot log washer,

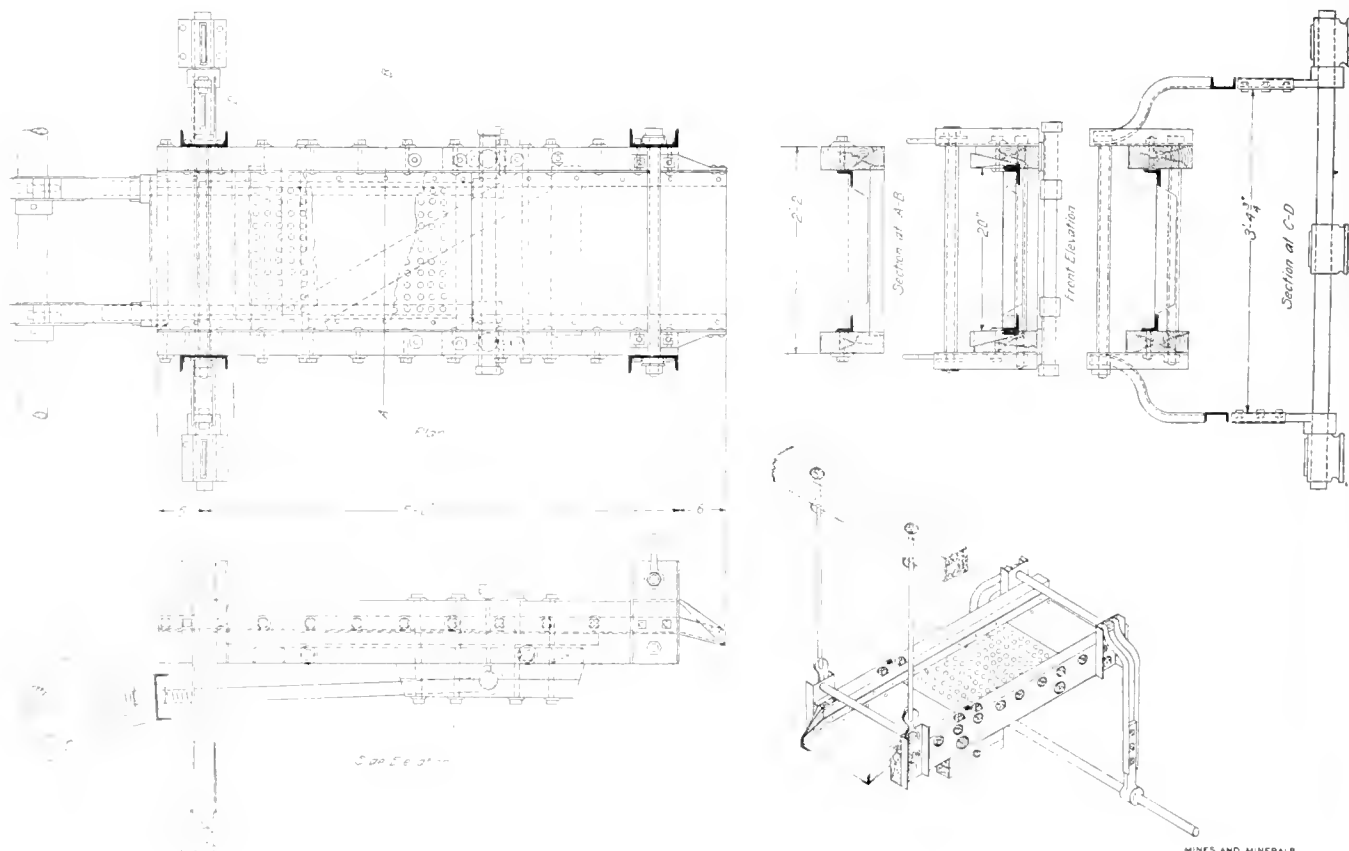

FIG. 1. SHAKING SCREEN

screening it perfectly through a $\frac{1}{2}$ -inch round-hole punched screen and delivering the oversize to a picking belt. Ten tons per hour can be screened clean; and, by placing a water spray over the middle of the screen the oversize is delivered in a clean condition to the picking belt. Of course if the tonnage demanded more screening area, a longer screen could be placed upon the same frame.

The repairs have been few and infrequent. After running for 2 years the hardwood boxes have just been replaced; one of the rocker-arm castings broke after a few weeks run, but was quickly brazed in the blacksmith's forge and put back in service; and the wear of the eccentrics has been taken up from time to time. These eccentrics were an easy running fit on starting up, with $\frac{3}{16}$ -inch shims between the strap lugs, and these shims are now reduced to $\frac{1}{16}$ inch. The wear at this point is heavy, as a rule, and the only way to reduce it is to put in heavy eccentrics running on a heavy shaft. For a screen of the size illustrated, the shaft should be $3\frac{7}{16}$ inches, running in heavy boxes, one just outside each eccentric and one between them. Of course, if such a screen had to run on very abrasive material the wear would be heavier than in the case before mentioned, but the only additional repairs required would have been an occasional punched screen and a few steel-plate liners, all of which could be easily put in place.

In setting the screen the rocker-arms should be vertical when the eccentrics are on the front stroke and the points of attachment of the hangers should then be forward from the vertical a distance equal to the length of the stroke. When so set the maximum travel of feed will be obtained with the minimum stroke. In our case the screen is hung with an inclination of $1\frac{1}{2}$ inches per foot and it runs with a $1\frac{1}{2}$ -inch stroke at 250 revolutions per minute.

來 來

Book Review

A MANUAL OF FIRE ASSAYING, by Charles H. Fulton, 210 pages, illustrated. McGraw-Hill Book Co. The second edition of this work contains a number of additions and corrections. Its author is well known for his long connection with the South Dakota School of Mines, and his present occupancy of the chair of metallurgy at the Case School of Applied Science.

The book is intended not only as a college textbook, but as a guide to the practical assayer. All through the work may be found suggestions that have been found worth while in the every-day operations of practicing assayers. The writer has endeavored to make his book strictly up to date by describing and illustrating the latest devices and schemes for accomplishing desirable results rapidly and accurately. The reader is impressed with the research work that must have preceded some of the statements made, and hence feels assured that these statements may be relied upon, both theoretically and practically. Portions of the book might be denominated stoichiometry, but there is enough only of this science given to show the principal reactions involved in the operations of smelting on the small scale that constitutes assaying.

The author sticks strictly to fire work, except in the instance of wet assays of bullion. The details of crucible fusion, scorification, and cupellation are well handled. The assay of precious-metal ore carrying different kinds of gangues and base metals is explained. Instructions are given for the preparation of test silver and proof gold. One chapter is devoted to the assay of platinum ores, a determination that has always proved difficult. The fire assay for tin is also carefully handled.

BUILDING STONES AND CLAYS, by Edwin C. Eckel, C. E., illustrated, \$3, net. Wiley & Sons. This new work of 260 pages is written in the interest of the building trades. The author has dwelt at some length upon the geology of the common rocks used as building stones, and upon various kinds of clays.

He is very frank in stating that "the term granite, as used in the stone industry, and as it will be employed usually in the present chapter, includes practically all of the igneous rocks except the traps and serpentines." In addition to the acid igneous rocks thus covered, the book treats of basic igneous rocks, serpentine and soapstone, slates, sandstones, limestones, and marbles. Each of these types is discussed along the lines of origin, physical properties, distribution, and production. Field examinations of stone properties and the laboratory tests desirable in arriving at the valuation of such lands are explained. Very little is said about the operations of quarrying.

UNITED STATES GEOLOGICAL SURVEY PUBLICATIONS, WASHINGTON, D. C. Bulletin No. 459, Results of Spirit Leveling in Missouri, 1896 to 1909 Inclusive, by R. B. Marshall, Chief Geographer; Bulletin No. 497, A Reconnaissance of the Jarbidge Contact, and Elk Mountain Mining Districts, Elko County, Nev., by F. C. Schrader; Bulletin No. 499, Coal Near the Black Hills, Wyoming-South Dakota, by R. W. Stone; Bulletin No. 500, Geology and Coal Fields of the Lower Matanuska Valley, Alaska, by G. C. Martin and F. J. Katz; Iron-Ore Reserves of Michigan in 1911, by C. K. Leith; The Production of Asbestos in 1911, by J. S. Diller; Potash Salts Summary for 1911, by W. C. Phalen; The Production of Lead in the United States in 1911, by C. E. Siebenthal. Mineral Resources of the United States for 1910, Part II, Non-metals.

DEPARTMENT OF COMMERCE AND LABOR, WASHINGTON, D. C., BUREAU OF LABOR, Bulletin No. 96, Hours and Earnings of Women Workers in Maryland and California, Employment of Children in Maryland Industries, Massachusetts Manufacturers' and Employees' Health, and German Workmen's Insurance Code, July 19, 1911. Bureau of Standards Technologic Papers No. 3, Tests of the Absorptive and Permeable Properties of Portland Cements, Mortars, and Concretes Together with Tests of Damp-Proofing and Waterproofing Compounds and Materials, by Rudolph J. Wig and P. H. Bates.

BUREAU OF MINES, WASHINGTON, D. C., Technical Paper No. 10, Liquefied Products From Natural Gas, Their Properties and Uses, by Irving C. Allen and George A. Burrell; Bulletin No. 23, Steaming Tests of Coals and Related Investigations, September 1, 1904, to December 31, 1908, by L. P. Breckenridge, Henry Kreisinger, and Walter T. Ray.

WASHINGTON GEOLOGICAL SURVEY, Henry Landes, State Geologist, Seattle, Wash., Bulletin No. 7, Geology and Ore Deposits of the Index Mining District, by Charles E. Weaver.

INTERSTATE COMMERCE COMMISSION, WASHINGTON, D. C., Twenty-third Annual Report on the Statistics of Railways in the United States for the Year Ending June 30, 1910.

MICHIGAN GEOLOGICAL AND BIOLOGICAL SURVEY, LANSING, MICH., Publication 7, Geological Series 5, Surface Geology of the Northern Peninsula of Michigan, by Frank Leverett.

APPRAISAL OF MINING PROPERTIES OF MICHIGAN, by the State Board of Tax Commissioners, Lansing, Mich.

REPORT OF THE STATE MINE INSPECTORS OF WYOMING for 1911, Cheyenne, Wyo.

BUREAU OF SCIENCE, MANILA, P. I., The Mineral Resources of the Philippine Islands, with a Statement of the Production of Commercial Mineral Products During the Year 1910, by Warren D. Smith, Chief.

REPORT OF THE ROYAL COMMISSION OF THE IRON AND STEEL INDUSTRY IN NEW SOUTH WALES, together with Copy of Commission, Evidence, etc., Sydney, New South Wales, Australia.

NEW ZEALAND DEPARTMENT OF MINES, Geological Survey Branch, P. G. Morgan, Director, Wellington, New Zealand, Bulletin No. 13 (New Series), The Geology of the Greymouth Sub-division, North Westland by Percy Gates Morgan.

PAPERS AND REPORTS RELATING TO MINERALS AND MINING IN NEW ZEALAND, comprising Statement by the Minister of Mines; Report on the Goldfields; Report on Coal Mines and State Coal Mines. Minister of Mines, Wellington, New Zealand.

Reducing California Dredging Costs

Economies That Have Resulted From the Use of Dredges Having Buckets of Larger Capacity

By Al. H. Martin

An industry's merit is measured by its earning power. Every reduction in the expense account means a corresponding augmentation of gross profits. Consequently the mining industry is vitally concerned in methods contributing to an increase in profit. Since the days of 1898, when the first California dredge was commissioned, the tendency has been to cut down operating costs to the extent that gravel of low quality might be economically handled. The dredges yield annually approximately \$9,000,000, and the industry has made strides in this state unexampled in any other section of the world.

The best low cost record ever attained by any dredge operating under like conditions is reported from the Yuba River fields, where Yuba dredge No. 13 in January, 1912, handled 320,000 cubic yards of gravel at a reported cost of 1.85 cents per cubic yard. Other dredges have accomplished work at lower costs than this, but not under the difficulties encountered. The dredge is operating in the Yuba River field, Yuba County. The deposit of auriferous gravel ranges in depth from 60 to 70 feet, the old river channel being overlaid by an enormous quantity of hydraulic tailing washed into the valley from the foot-hills of the Sierra Nevada Mountains. The tailing in the Yuba Basin ranges in depth from 10 to 40 feet. While this carries some gold, it is not sufficient to encourage dredging. Below this immense mass of tailing is found the true deposit, resting on a volcanic ash rock.

The gold content ranges from 10 to 30 cents per cubic yard throughout the deposit. Occasional drill holes from 90 to 110 feet deep show gravel and some gold below the bed rock. Generally, however, gold occurs only above the true bed rock. In dredging, a portion of the soft, sticky bed rock is handled. The water level varies from 4 feet below the surface to several feet above.

Yuba No. 13 went into action August, 1911. The boat was built by the Yuba Construction Co. The hull has a length of 150 feet, with a width of 58.5 feet, and 12.5 feet depth. The housing overlaps the hull 5 feet on each side, giving a total width of 68.5 feet; 820,000 feet of lumber was consumed in building the hull and housing, the best of Oregon pine and other favored timber being employed. The digging ladder excavates to a depth of 65 feet below the water line, is of plate-girder design, and carries ninety 15-cubic-foot buckets of the close-connected type. Total weight of digging ladder and bucket line is about 700,000 pounds. The 111,721-pound washing screen is 50.5 feet long, with a diameter of 9 feet. It is of the revolving type and roller driven. The two steel spuds each have a weight of 44 tons. The gold-saving tables are of the double-bank type, with an approximate riffle area of 8,000 square feet. The main tables are reinforced by a "save all," located to catch any gold escaping during the passage of the buckets over the well. The stacker hoist weighs 3,732 pounds. The tailing sluices are arranged to facilitate the discharge of sand close to the boat, or at considerable distance behind. By this means the hampering of the dredge by immediate deposits of waste is escaped. The conveyer stacker has a length of 275 feet by 42 inches wide and is an ordinary belt conveyor. The stacker ladder is 142 feet long and of the belt-and-roll type. Nine motors are employed to operate the machinery and pumps, the total electrical capacity having a rating of 10,722 horsepower. The total weight of the fully equipped dredge exceeds 232 tons. Most of the machinery for this boat was furnished by the Bucyrus company. This is the largest dredge in the world digging at a depth of 65 feet below water.

Two or three years ago a California dredge handling gravel around 3 cents per cubic yard was considered a brilliantly successful machine. And conditions were more favorable for the establishing of low working costs than prevail in the Yuba River field. The average costs ranged from slightly over 4 to past 5 cents per cubic yard, with many companies reporting costs exceeding 6 cents. These results were obtained with dredges of less than 13-cubic-foot capacity. With the installation of the larger 13.5-cubic-foot and 15-cubic-foot boats, costs were cut down to from 2.15 to 2.60 cents per cubic yard. The best record ever reported from any dredge was given out by the California State Mining Bureau, in Bulletin 57, which states that a 13.5-cubic-foot boat handled 230,636 cubic yards of gravel at an average cost of 1.60 cents per cubic yard. This dredge was digging to a depth of about 18 feet. Two or three other boats reported dredging costs ranging from 1.84 to 2 cents per cubic yard, with conditions generally favorable for low operating costs.

The greatest factor in the reduction of costs per cubic yard has been the steady gain in capacity of the buckets. Where the 5-cubic-foot bucket dredge handled gravel at an average cost of over 5 cents per cubic yard, the 15-cubic-foot type does the same work at about 2 cents. The difference is due largely to the vastly larger percentage of material handled, although increased gold-saving facilities and other improved features have had an important influence.

The company reporting the best record in reducing dredging costs is Natomas Consolidated of California, operating the largest number later-type dredges in the state. From January 1, 1909, to July 1, 1911, this company handled 44,542,141 cubic yards of gravel at an average cost of 4.13 cents per cubic yard. The greater part of this work was done with 13.5, 9, and smaller cubic-foot bucket dredges. In the first half of 1911, with several 13.5 cubic-foot boats active, and one 15-cubic-foot dredge operating part time, the cost was cut down to 3.77 cents per cubic yard with 10,793,891 cubic yards treated, following the installation of dredges of larger capacity, showing a net profit of over \$800,000 in six months. The treated ground yielded an average recovery of 9.82 cents per cubic yard.

The Oroville Dredging Co., Ltd., that has been operating with small dredges in the Oroville field reports average working costs of about 5.05 cents per cubic yard. Dredging conditions are favorable in this district, the gravel being excavated without difficulty to an average depth of 20 to 30 feet. The Yuba Consolidated Gold Fields, operating the deep deposits in the Yuba River field, handled 13,970,728 cubic yards of material in 1910 at an average cost of 5.67 cents per cubic yard. In 1911 approximately 15,000,000 cubic yards were treated, at costs considerably under the 5-cent point. The later dredges of the Yuba Consolidated Gold Fields and Natomas Consolidated of California, the two principal dredging concerns of the state, are of the 15-cubic-foot type.

It is evident, therefore, that in the future reduction in California dredging costs will result mainly from the installation of still larger dredges, some engineers predicting the building of 18 and possibly 20-cubic-foot buckets within a few years. It has been demonstrated that the more ground there is handled, the smaller is the operating cost per cubic yard.

It is interesting to note that power plays one of the principal parts in operating costs, the consumption of electricity representing an average of 15 per cent. to 21 per cent. of total expense. The installation of large motors on the new giant dredges has naturally forced the power cost upward. In the earlier dredges the average amount of electricity used was about 150 to 200 horsepower. On the new dredges the rated capacity of the electrical equipment has been increased to 1,700 horsepower. Labor and materials average about 22 per cent. to 27 per cent. Repairs and maintenance form the bulk of the remaining costs. Water is plentiful in all the fields, and its employment is attended with slight expense.

Bonus System on Los Angeles Aqueduct

Rules of Operation and Method of Computing Bonus Footage and Earnings

It is a significant fact that before the paying of bonuses to the men working on the Los Angeles Aqueduct no records for work of any kind were broken or even equaled, whereas within a few months after bonus payments began, record smashing advances were made. When bonus payments increase a man's wages by \$1.50 or more a day, as was the common case on the aqueduct tunnels, similar results may be looked for elsewhere. The following rules governing the payment for bonus footage in tunnel work may prove useful as a guide in other somewhat similar work. These rules were approved by the Board of Public Works of Los Angeles and were amended from time to time. The following are the rules:

1. *Length of Period and Time of Measurements.*—Ten days shall constitute a period. The first period to be from the 1st to the 10th of the month, inclusive; the second from the 11th to the 20th, inclusive; the third from the 21st to the end of the month. Bonus payments shall be allowed upon the basis of measurements made at the close of each 10-day period.

2. *Employees Entitled to Bonus.*—The following named classes of employees shall be allowed to participate in bonus payments: Tunnel foremen, when in charge of more than one bonus crew; shift bosses, miners, muckers.

3. *Tunnel Foreman.*—The tunnel foreman shall not be considered as one of the "shift crew." If he is in charge of more than one bonus crew he shall be allowed bonus based upon the "mean" bonus progress per shift of all bonus crews under his supervision.

4. *Shift Boss.*—The shift boss shall be considered as one of the shift crew. He will participate in the bonus on the same basis as the men of the crew under his direction. An exception to this rule is made when a shift boss is placed in charge of two or more shifts in different headings. In this case he would be placed on the same basis as a foreman, to wit, not be considered as one of the crew, and would be allowed bonus based upon the mean bonus progress.

5. *Number of Shifts Allowed.*—The number of shifts worked in a heading during a day of 24 hours shall be deter-

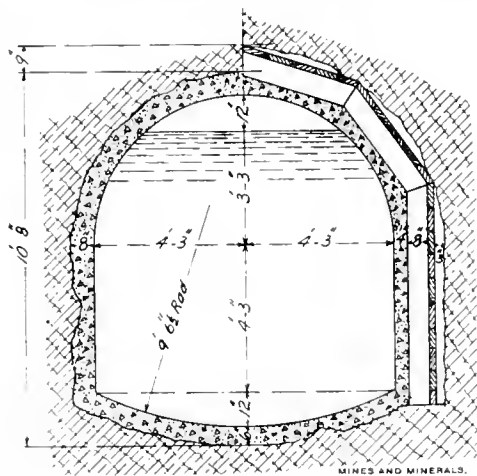

FIG. 1. SECTION OF TUNNEL NO. 17, JAWBONE DIVISION

mined by the engineer or superintendent in charge of the work after consultation with the chief engineer.

6. *Trimming and Timbering.*—All trimming must be done by the crew sharing the bonus. If the timbers are placed by the miners from the standard crew in a given 10-day period, then that portion of the tunnel shall be considered as a timbered section; otherwise it shall not be so considered.

7. *Continuous Work and Exceptions.*—Only men who work continuously through the 10-day period—with the following exceptions—shall be entitled to the bonus:

(a) Any employe, entitled to bonus earnings, who is injured or becomes ill during a period from conditions arising directly from tunnel construction, shall participate in bonus in

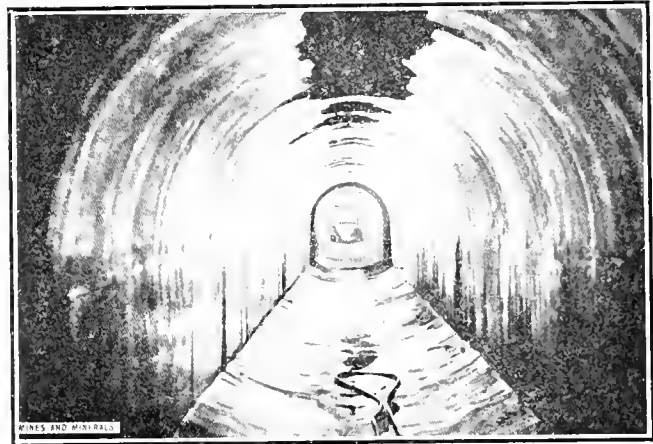

FIG. 2. INTERIOR OF JAWBONE TUNNEL

proportion to the number of shifts worked by him during said period.

(b) If an employe, entitled to bonus earnings, is transferred during a period from a heading to another part of the work for reasons other than his own request, he shall participate in bonus in proportion to the number of shifts worked by him on such heading.

8. *Interruptions of Work.*—If the work is interrupted by the failure of power, shortage of material or supplies, floods, cave-ins, or other causes beyond the control of the men, the men shall be entitled to bonus pay in proportion to the number of shifts worked by them during period in which such interruptions occurred.

9. *When Both Timbered and Untimbered Work Is Done by the Crew in the Same Period.*—To establish a uniform system of computing bonus earnings in above case the following formula will be used:

FORMULA.—

$$\frac{x+y}{a+b} = \text{average base rate per shift.}$$

EXAMPLE.—

Let x = timbered progress = 25 feet;
 y = untimbered progress = 30 feet;
 a = required timbered per shift = 2 feet;
 b = required untimbered per shift = 2.5 feet;
 s = number of shifts during period = 20.

Then

$$\frac{x}{a} = \text{shifts required at base rate;}$$

$$\frac{y}{b} = \text{shifts required at base rate.}$$

Or, substituting values,

$$\frac{25}{2} = 12.5 \text{ shifts required at base rate}$$

$$\frac{30}{2.5} = 12.0 \text{ shifts required at base rate}$$

Total, 24.5 shifts required at base rate

$$\frac{25+30}{24.5} = 2.245 \text{ average base rate.}$$

$$20 \times 2.245 = 44.9 \text{ feet} = \text{progress required.}$$

$$55 - 44.9 = 10.1 \text{ feet} = \text{bonus footage.}$$



FIG. 3. PORTAL OF FINISHED TUNNEL, SAUGUS DIVISION

10. *Computations of Bonus Footage and Earnings.*—The computation of bonus footage shall be made by dividing the total number of feet run during the period by the total number of shifts worked during the period. From this average footage per shift there shall be deducted the base rate of progress required, and the remainder, if any, will be the bonus footage per shift. The bonus earned *per man* during the period, will be the number of shifts in which he worked, times the average bonus footage, times the bonus price per foot. (Provided all conditions as outlined in these rules are complied with.)

EXAMPLE 1.—Three shifts working 10 days.
 Total progress for period, 150 feet.
 3 shifts \times 10 days = 30 shifts worked
 150 feet \div 30 shifts = 5 feet per shift
 Base rate of progress = 3.5 feet per shift
 Bonus footage 1.5 feet per shift

Bonus earned for period *per man* = 1.5 feet \times 10 shifts \times 25 cents per foot = \$3.75.

EXAMPLE 2.—One shift working 10 days.
 Total progress for period 50 feet.
 1 shift \times 10 days = 10 shifts worked.
 50 feet \div 10 shifts = 5 feet per shift
 Base rate of progress = 3.5 feet per shift
 Bonus footage 1.5 feet per shift

Bonus earned for period *per man* = 1.5 feet \times 10 shifts \times 25 cents per foot = \$3.75.

11. *Interpretation of Rules.*—If any of the above rules are not clear to the engineers or superintendents in charge of work, such rule must be referred to the chief engineer for interpretation.

12. The chief engineer shall determine what tunnels shall be given certain base rates and bonus per foot as outlined in the schedules for the various divisions.

The base rate for determining the bonus depended on whether the rock was soft or hard, on whether the excavation was timbered or untimbered; on the number of men on each shift advancing the work; whether the work was done by machine drills or hand drills, and finally on the square feet of cross-section for the tunnel. Bonus schedules were prepared and approved for tunnel driving on the Little Lake division, Boulder Peak and Grapevine sections of Division 5-A; the Jawbone division; the North Antelope division; the Elizabeth tunnel and the Saugus division. As the Los Angeles Aqueduct is 217 miles long it follows that there were different kinds of rock which varied in hardness, consequently the bonus footage varied. Two schedules, one for the Jawbone division and the other for the Saugus division of the tunnel, are given:

BONUS SCHEDULE FOR TUNNEL WORK IN THE JAWBONE DIVISION

Capacity of Tunnel Second-Feet	Class of Rock	Timbered or Untimbered	Class of Work	Base Rate Per Shift Feet	No. of Men Per Shift	Bonus Per Man Per Foot Per Shift Cents
430	Soft	Untimbered	Hand	4.0	9	25
430	Soft	Timbered	Hand	4.0	9	25
430	Hard	Untimbered	Hand	2.5	10	25
430	Hard	Timbered	Hand	2.0	10	25
430	Hard	Untimbered	Machine	3.0	11	40
430	Hard	Timbered	Machine	2.3	11	40

BONUS SCHEDULE FOR TUNNEL WORK IN THE SAUGUS DIVISION

Capacity of Tunnel Second-Feet	Class of Rock	Timbered or Untimbered	Class of Work	Base Rate Per Shift Feet	No. of Men Per Shift	Bonus Per Man Per Foot Per Shift Cents
1,000	Hard	Untimbered	Hand	2.3	13	40
1,000	Hard	Timbered	Hand	2.0	15	40
1,000	Hard	Untimbered	Machine	3.0	15	40
1,000	Hard	Timbered	Machine	2.5	17	40
1,000	Soft	Untimbered	Hand	3.0	13	35
1,000	Soft	Timbered	Hand	2.5	15	35
420	Soft	Untimbered	Hand	4.0	11	25
420	Soft	Timbered	Hand	3.5	11	25
420	Soft	Untimbered	Machine	5.0	11	25
420	Soft	Timbered	Machine	4.5	11	25

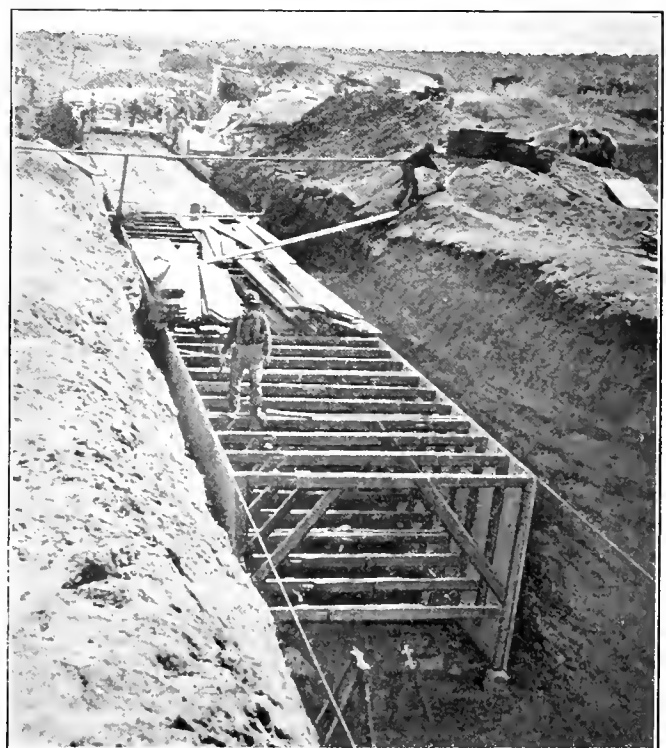

FIG. 4. CONDUIT FORM, MOJAVE DIVISION, LOS ANGELES AQUEDUCT

The Bureau of the Los Angeles Aqueduct gave the aggregate length of the aqueduct as 217.56 miles and the material to be worked through as follows:

Unlined canal, 21.08 miles; lined canal, 152.25 miles; rock tunnels, 17.24 miles; earth tunnels, 11.08 miles; siphons crossing cañon, 14.19 miles; flumes, 1.72 miles. The Sagus division was driven through 54,000 feet of tunnels composed of compact sand and gravel free from water, and also some soft shale. This tunnel required cement lining as shown in Fig. 3. The Jawbone division had 59,448 feet of tunnels that were driven by hand through sand and cement gravel, and some decomposed granite. A section of this tunnel is shown in Fig. 1, but the entire excavation was 13 feet wide and 12 feet 3 inches high. The ground was drilled by hand augers and the holes charged with 40-per cent. dynamite or with black powder either of which broke the material so fine it could be rapidly shoveled. Of course such material could be advanced rapidly, in cases 11.7 feet per shift and at the low cost of \$6.45 per linear foot. The tunnel was lined with concrete as shown in Fig. 2, which is reproduced from a flash-light photograph.

From the data given it will be noticed that the major part of the aqueduct was lined canals. That division known as the

it was discovered is only about 2 hours drive from Almeria, Spain. No work has as yet been done to show the real nature of the deposits, but the owner is said to have estimated the quantity at 60,000,000 tons. The lode extends about 3 miles. Señor Calafat is said to be erecting works near Madrid to put the mineral to a practical test and several carloads have been shipped for treatment in the furnaces. The analysis is given as follows: Anhydrous sulphuric acid, 34.77 per cent.; oxide of aluminum, 37.98 per cent.; potash, 9.64 per cent.; water, 17.61 per cent. The specific gravity is 2.75; hardness, 2.50 to 3.

采采

The High Grade Mining District

Much is being said about a small area in northeastern California that is going to show wonderful results this coming summer. While not in a position to state anything about the real virtues of this district, a sketch map is published to give the reader some notion as to its position.

As will be seen, it is right in the very corner of the state. It is in the Warner Mountains National Forest Reserve, directly east of Goose Lake. New Pine Creek is the nearest railroad point. This town is 225 miles from Reno, on the Nevada, California and

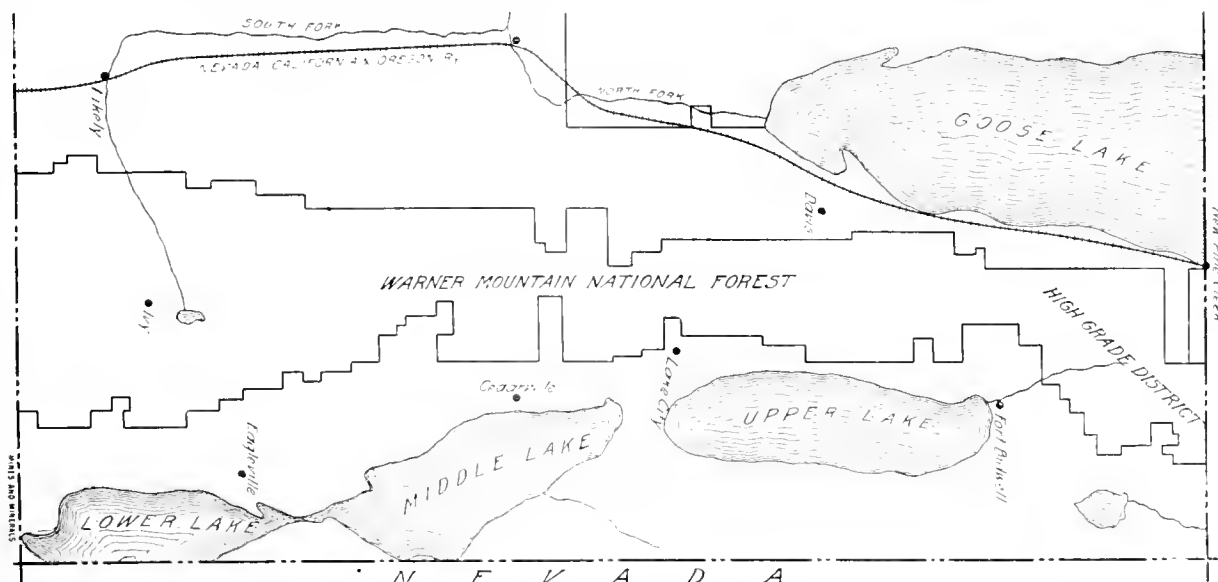

MAP OF HIGH GRADE DISTRICT, CALIFORNIA

Mojave, which crosses the western end of the Mojave desert, is practically all lined canal. The ground in this desert is such that seepage would be exceedingly great, and this, added to evaporation, would diminish the flow of water to such an extent that probably Los Angeles would receive little of the supply were the canal not lined with concrete. The forms used when lining the Mojave ditch are shown in the foreground, Fig. 4, while in the background is shown the concrete plant and some of the finished work.

In Vol. 31, page 102 of MINES AND MINERALS will be found an article by W. C. Austin, who was superintendent of the South Portal of the Elizabeth tunnel, in which the details and costs of driving are given.

In the same volume, page 135, R. L. Herrick, one time Western Editor of MINES AND MINERALS, describes the Los Angeles aqueduct in detail with suitable maps and illustrations.

采采

The New Ore, "Calafatita"

Acting Consular Agent James Murison, at Almeria, Spain, states that the new mineral Calafatita is a double sulphate of aluminum and potash (sulfato doble alumico-potasico) and is named after its discoverer, Señor Calafat. The district in which

Oregon Railroad. New Pine Creek is about 8 miles from the center of the new field, so far as the present developments have determined ore bearing formations.

Fort Bidwell is said to be the preferable center of supplies for the district for the reason that the wagon roads become free from snow 1 month earlier in the spring and remain open much longer in the fall. To reach Fort Bidwell, one leaves the same railroad at Alturas (188 miles from Reno) and travels 55 miles by stage.

It is hoped that this new district will not be overestimated as most of the precious-metal-mining districts usually are. If it is really worthy, let it be so treated and permitted to stand upon a reputation and not a notoriety. The coming season will probably tell the tale.

A recent letter from a man on the ground reads: "There is considerable ground open for location in the district. There is any amount of open ground in the outlying foot-hills that have not been prospected. Timber is abundant, and there is plenty of fine water everywhere in the hills." It is said that the country is of eruptive formation, the prevailing rocks being rhyolite, andesite, and porphyries. The ore is found in veins that are well defined by walls, and in some cases traceable on the surface. This latter feature, probably is limited, for heavily timbered areas usually have a deep soil that conceals the rocks in place.

Considerations Before Opening Mines

Legal Matters, Topography, Transportation, Climate, Labor, Supplies, Extent of Property

By Arthur J. Hoskin

The word "exploitation" is used by many mining men and engineers to signify a plan of so opening up ore deposits as to render the contents removable. The same persons use the word "mining" to mean the operations involved in the actual extraction of the ore exploited. It is sometimes difficult to draw any line between the meanings of these two words for, as handled by different men, with varying shades of intention, they are sometimes synonymous. Thus, if exploiting an underground mine, which carries ore right from the surface, means developing the mine in such a way as to provide for a large, steady production, it is difficult to see why the ore taken out in this process cannot be said to be "mined."

By "dead work" is usually meant that work of opening up a mine which will put or keep it in a producing condition, but which does not supply any remuneration in the shape of ore (or coal). Again, as used by some men, there is little distinction between this work and exploitation. There may, however, be lines reasonably drawn between these three terms, and therefore the following definitions are proposed:

"Dead work" is such work as is necessary to develop an ore body, but it does not produce any ore. It may be prosecuted for drainage or ventilation purposes or for creating passageways for men and products.

"Exploitation" is also work performed in opening up or developing a property, but it does not contemplate the value of the extracted materials which may, or may not, be of any commercial importance. Indeed, much ore might be extracted during work which was carried on merely to define extents or boundaries of ore bodies. In this last supposition, the original sense of exploration is brought out and this should serve to fix the definition clearly in mind.

"Mining" may be restricted to mean the methods and work involved in the profitable production of the mine's ore (or coal). The term would not be used to cover operations of shaft sinking, tunneling, and the like, unless such work be in the valuable materials. Mining may be said to begin whenever there is produced an output upon which there is some profit. Exploitation may be in valuable ground. If so, we may say that mining is in progress during the exploitation. The driving of levels or drifts in an ore body—or entries in a bed of coal—produces the valuable products of the mine, and we may, therefore, consider that mining is taking place.

The driving of a cross-cut, or level, in a vein is either exploitation or mining. Dead work produces *no* ore. Exploitation may, or may not, produce ore. Mining must *produce* ore.

Throughout all of the above and the following discussion, the reader should bear in mind the point that the word "coal" may be substituted for the word "ore" without altering the substance of the definitions or the conclusions.

Before a mine is opened, the economist-manager will consider many items. In the first place, care must be exercised in the examination of the title to the property. A mineral property may have passed through the most complicated kinds of transfers of fractional interests in the title, just as is true with ordinary real estate. The abstract must be traced back clear to the issuance of patent from the government, and then back to the original location. With an undeveloped property (a prospect), this precaution is essential to estop any possible pretensions to ownership by outside parties, in case the ground subsequently turns out to be exceptionally valuable. It has often been the case that no obstructions from any adverse claimants have been met until owners have, in good faith and at great

expense, developed splendid mines. Then suits for possession or partial ownership have been instituted, sometimes with marked success for the plaintiffs. There are persons who make it a special line of business to examine titles to mining property, and it is economy for the average manager to employ such experienced men to attend to these matters.

Topographical considerations will hold a place in the study preceding the opening of a new mine. The nature of the surface of the property and the surrounding country will largely influence in the selection of the proper site for the mine's mouth. Neglect upon this point has been a common cause of failure in mining operations.

A mine opening must be away from all dangers of snow slides, rock slides, cloud bursts, and deluges from overflowing streams or breaking dams. It may make a difference in the mine's ventilation as to which direction the prevailing winds blow and therefore upon which side of a hill the mouth be opened.

Transportation facilities must be given due thought. If means are not already at hand, one must inquire into the feasibility of constructing some form of carrier; and here, again, will enter the question of the surface contour. If a railroad is out of question, possibly an aerial tramway may be considered. These modern conveyances stop at no obstacles of surface configuration and are dependent only upon the necessity of having the point of delivery lower in altitude than the point of loading at the mine. With some of the modern improvements in these installations, mine products are being transported up hill as well as down hill, through the application of power. In mining regions it is generally the case that the mines themselves are above the settlements in which are the railroads or treatment plants, so that the mine products may be conveyed readily by the natural force of gravity.

Climate holds an important place in the economics of mining. A very rich piece of ground may prove a losing proposition in some portions of the world where the climatic conditions are such as to render operations possible during only a very small portion of the year. Extremes of heat or cold, malaria or other pestilential obstacles, long rainy seasons with floods, or the hostility of native humans, beasts, or insects have accounted for the abandonment of seemingly attractive mining projects.

The question of labor must be given due thought. It is true that the best miners on earth are Americans. We do not deny that many of our miners are of foreign birth, but the fact remains that they (these acquired Americans) perform better and more intelligent service than do their fellow countrymen who have not been adopted into our country. Our men are in demand in the mining development of foreign countries. An American mine manager will always experience dissatisfaction while endeavoring to get, from natives in foreign parts, the same efficiency that he is accustomed to receive from the miners "in the States." He may be paying a good deal less per capita for such labor, but he finds he is actually paying more per ton of output.

Within a single country, there are notable differences in the worth of labor. The natives of some of the Mexican states are far preferable to those of other states. Even within the United States there may be discerned material differences between the efficiencies of the inhabitants of various sections when it comes to mining. One cannot procure as competent miners in some of the agricultural states as in the typical mining states. This is but to be expected. For instance, there are deposits of lead ore in the "moonshine" regions of Kentucky which have never been successfully worked, and the real cause of failure, in the writer's belief, lies in the inability of superintendents to obtain miners either from that region or from the outside. The residents will never become miners; outsiders will not enter for work under existing sociological conditions.

The question of unionism is sometimes held by managers as

a deciding one when debating the opening of a mine. While there are those who will broadly denounce such organizations, there may be found other, and just as successful, mine operators who declare that the effects of union control over their miners are beneficial to their companies' interests. Probably, the greatest objection to unionism raised by operators is that they resent the dictation that accompanies the inauguration of union rules in mines. The owners and managers prefer to run their own business to suit themselves. Some managers are so imbued with this conviction of their own rights, that they will refuse to open up mines or, if they are operating, they will close down their mines before they will submit to the demands made upon them by the union officials.

On the other hand, there are mine managers who prefer the presence of some central, labor-controlling body; for they believe that the men who belong to such a large federation or organization will, and do, have less complaint to make and therefore work more freely than is the case with the independent laborers. The argument is that these union men are satisfied because they feel that their interests are being looked after with a sort of attention that they, individually, could not give.

This is not a place to discuss the crimes that have been laid at the doors of both the labor organizations and the mine owners' associations. It is safe to assume that wrong has probably been done upon both sides. But, it is furthermore right to believe that most of the crimes were not authorized, nor recognized, by the officers of either side. Individual members must not be taken as averages of the membership in any kind of civil, social, or political organization.

It seems entirely wrong that politics should enter into the considerations of a mine manager whose operations are apparently so apart from affairs of state; but the fact remains that there are places where mining operations cannot be carried on without the good-will of certain officials of the state or national governments. It is not advisable to enter into any compromising terms to gain privileges for carrying on any legitimate business, for there are other, better ways, generally, of attaining the justice that is deserved.

One must not omit to investigate the sources of supply for all the needs of a mine and its camp. There are many kinds of material needed to keep a mine going. Fuel, machinery, timber, water, food for men and beasts, lumber, and all household furnishings and necessities must come from some markets or natural sources. It behooves the cautious manager to see that all these things may be had in ample amount and at figures which will not prove annihilating to his business.

In Utah, there are mines which have all their timbers framed in and shipped from the forests of Oregon, the sawing and framing being done before shipment, to save in freight. The fir of Oregon is shipped to distant Australia for mining purposes. The arid camps of Nevada get their supplies of timber from the sister state, California. The Michigan mines are fortunate in being in a lumber region. Colorado's metal mines are more favored in the matter of timbers than are the coal mines of the same state. Most of the coal mines are upon barren plains, while the metal mines are chiefly in the wooded mountains.

Water may be too scarce for the needs of a mine or its community. There may not be sufficient to supply boilers or a mill, or for the domestic purposes of the workers. On the other hand, water may be so abundant in the mine workings as to prove a deterrent factor in profitable operation. With shaft mines, from which water must be delivered mechanically, the costs of such drainage are frequently prohibitive of mining, with deep workings and low grades of ore. Some mines in arid regions have been fortunate in striking such flows of underground water that it has been possible to operate mills right at the mines. In this way, the cost of water hoisting has been more than compensated in the milling benefits which, in turn, have decreased freights and treatment charges.

Machinery is usually purchased at centers of mining supplies and manufactures. San Francisco, Salt Lake City, Chicago, and Denver are the principal rendezvous in the West for mining men in need of machinery. Mexico City is, similarly, the outfitting point for the mines of southern Mexico. The United States holds the supremacy of the world in the matter of equipping mines and mills, large orders of American-made mining machinery being shipped to even the antipodes.

The nearer a property is to a depot of supplies, the less is bound to be the cost of getting goods on to the ground. It is this last item, the delivery of goods, that must be recognized as a very pertinent and sometimes a critical factor upon the cost side of mining accounts. Mines that are remote or in rugged countries are frequently dependent upon animal transportation. In some cases, machinery going to the mines must be so built that it may be taken apart into small portions suitable for loading upon the backs of horses or burros, or even, in the Andes, upon the frail llamas.

Operations, if planned to be conducted for a long term of years and therefore warranting the installation of large and expensive plants, should be based upon the holding of extensive ore-bearing ground. Here enters the notion of the shape and size of a mining property.

With some kinds of mining ground, the best form for the holdings would probably be a compact, approximately equilateral tract, covering a reasonably large acreage. This would be the case with ores that occur in sedimentary beds, for instance, where it is advisable to have the mining plant centrally located so as to expeditiously work the entire area. This would also apply to a region like the Cripple Creek district which contains innumerable veins running in all directions but displaying no outcrops.

In other instances, the most desirable shape might be long, narrow strips so laid off as to contain the strikes of persistent lodes or veins, as those of the wonderful Comstock Lode region. The great Camp Bird mine in the San Juan region of Colorado was expected to be worked for many years to come because its owners exercised the precaution to possess the ground, for miles, containing the extension of the persistent vein from which millions have been taken. It is not acreage that counts here so much as linear extent.

In the Transvaal, land is held in rectangular blocks. The first owners of the ground took it up for agricultural purposes. This same statement is also true of the mining properties in the Joplin district of Missouri and Kansas.

In the case of the South African properties, every company has definite boundaries to which operations may be planned. Hence it is possible for the management to so plan any mine as to operate it at given rate for a predetermined life of the enterprise. The work is planned to maintain a certain output that will exhaust the ore bodies in just so many years, and all the equipment may thus be purchased with the forecast that it will serve its purpose and perform its economic share within the prescribed time.

This last notion becomes more readily understood if we consider the various types of ore bodies. With properties wherein there is no possible way of predicting the number, size, and worth of discoverable ore bodies, the life is wholly problematical and it is, therefore, difficult for a manager to decide how much he should expend in the initial equipment.

來 來

Utilizing Water in Mines

Where it is necessary to drop water 100 feet or more to a pumping level, it can be utilized to furnish power by conducting it through tight pipes instead of allowing it to find its own course through stopes, raises, etc. One Cœur d'Alene mine uses such power to drive a fan, and another drives a generator which supplies electric light to six stations of the mine.

Iodide Method of Copper Assay

A Method of Analysis for Certain Ores, which Gives Most Accurate Determinations

By *Thorington Chase**

During 1908 and 1909, while chemist at the smelter of the Mazapil Copper Co., Ltd., at Concepcion del Oro, Mexico, the writer experimented upon numerous methods of copper analysis, and from the results obtained concluded that the iodide assay was the most accurate for copper determinations, at least in the ores and smelter products of that center of metallurgical industry. This mode of analysis was chosen when the greatest accuracy was desired, being used for the daily averages of smelter products and the weekly and monthly averages of ore beds, mattes, and wastes. It must be remembered that the assay method here given was the one found best adapted, not only to the products in question but also to the conditions under which the work had to be performed and the class of native assayers who carried it out.

The ores smelted were of two kinds: Mixed carbonates and oxides; and sulphides, often carrying as high as 35 per cent. sulphur. Small traces of arsenic *As* were present, being combined with silver as arsenate. Bismuth *Bi*, and antimony *Sb*, were practically absent, though pockets of ore, discovered from time to time, contained as much as .03 to .08 per cent. *Sb*, which was combined with the *As* as a double salt of silver. Only traces of lead were present and the zinc in these ores was usually under 1 per cent.

Into an 8-ounce, pear-shaped, flare-necked glass flask 1 gram of ore or $\frac{1}{2}$ gram of matte was inserted with 10 cubic centimeters of concentrated nitric acid HNO_3 ; to which was added, in the case of the sulphides, from 1 to 3 grams of potassium chlorate, according to the probable content of *S*. About 5 cubic centimeters of concentrated hydrochloric acid HCl , was next added and the assay mixture boiled down to about 2 cubic centimeters upon the sand bath, it being constantly watched to prevent "spitting." Lead *Pb*, being practically absent in the ore and only a trace occurring in the furnace products, only the latter received at this point the addition of a few drops of sulphuric acid H_2SO_4 , slightly diluted, which, with a few moments of boiling, brought down the lead as insoluble sulphate.

Upon cooling, 20 cubic centimeters of distilled water was added, and the content of the flask, after being shaken well, was filtered into 500 cubic centimeter beakers and thoroughly washed, the residue in the flask being loosened and broken up with a rod to facilitate the washing. The filtrate was then warmed to $75^\circ C.$ and the copper precipitated with hydrogen sulphide H_2S . If more than 1 per cent. *Zn* was present, 5 cubic centimeters or more of HCl was added before precipitating, as its presence in the free state prevents the precipitation of the *Zn* along with the *Cu*. A rapid current of gas was next passed into the assay through a tube placed in the beaker's lips, the beaker being covered with a watch glass.

Precipitation of the copper from a H_2SO_4 solution of the assay with aluminum was found to give results slightly low, caused, the writer believes, from some ionic action in the solution, for though no copper was shown on testing the liquid immediately after the precipitation of the copper, subsequently a copper reaction often resulted and an appreciable amount was found therein when the copper in the assay was above 10 per cent. Precipitation with potassium or ammonium thiocyanate added several hours to the process and required careful neutralization of the assay with sodium hydrate $NaOH$. The results varied also, often because of carelessness on the part of the operator, or in the addition of the reagent in whose excess the resulting precipitate of cuprous thiocyanate is faintly soluble.

*Anaconda Mont.

After allowing the precipitated sulphide to settle and testing the clear liquid for traces of copper, the former was filtered and washed repeatedly with H_2S water until all trace of iron disappeared from the wash water. A porcelain casserole was then placed below the filter funnel, the filter perforated, and the precipitate washed into the casserole with as little water as possible, a washing with hot dilute 1:3 HNO_3 following, the aim being to keep the volume in the casserole at the minimum. The filter paper was then dried, charred in front of the muffle in a small porcelain crucible, and after treating on the sand bath with a few drops of concentrated HNO_3 the contents were added to those of the casserole, which now usually contained sufficient HNO_3 to oxidize the sulphur. The assay was now taken down at $100^\circ C.$, the operator taking care that the process evoked no change in the color in the bluish white residue which a too prolonged addition of heat changes to a dirty brown. The surface of the residue, upon removal from the heat, should still appear moist.

Upon cooling slightly, about 7 cubic centimeters of warm water was added in washing down the sides of the casserole, and the assay was allowed to stand at $100^\circ C.$ until perfect solution was attained and the volume was reduced to about 5 cubic centimeters.

The contents of the casserole were then filtered into a flask (like the one first mentioned, in case of ore or concentrate; or a 500 cubic centimeters flask, in the case of matte, etc.), the vessel being washed carefully with hot water and the filter paper receiving numerous washings with boiling water until the operator was confident no copper remained therein. The flask, now half full of liquid, was allowed to stand until its contents were the temperature of the laboratory.

The solution was then neutralized by the addition, drop by drop, of sodium carbonate solution Na_2CO_3 , aided by shakings, from time to time, until an excess of one drop was obtained, as shown by the characteristic permanent precipitate. The presence of a greater excess is undesirable and easily avoided. Too great an amount of sodium acetate, resulting upon the subsequent addition of acetic acid, causes a return of the blue color after the end point has apparently been reached. (This is also sometimes caused by too great dilution of the assay.)

From 2 to 4 cubic centimeters of acetic acid was then added and the vessel shaken and allowed to stand 5 minutes. Three grams of chemically pure potassium iodide KI was then added to the assay and permitted to dissolve, the assay being now ready for titration with the standard solution of sodium thiosulphate $Na_2S_2O_3$ (38 grams of chemically pure salt to the liter of distilled water). A second burette, containing this solution, diluted with three parts of H_2O , was used for the determination of the end point after nearly completing the titration from a first burette, containing the full-strength solution of hyposulphite. The hypo solution was changed every 3 weeks.

The starch solution, used as an indicator (made by treating $\frac{1}{2}$ gram of starch with 250 cubic centimeters of cold H_2O , and bringing to a boil), was prepared every two days and used cold, being added only after sufficient hyposulphite had been added to balance three-fourths of the copper in the assay, the free iodine serving as the best indicator up to this point.

The writer has found, that even with the most careful work, electrolytic assays often differ, original and repeat, on 10 per cent. copper, up to 15 per cent. while a practiced operator, using the above method, may check his work on up to 20 per cent. copper, within three to five hundredths of a per cent. and on matte, within ten hundredths.

采 采

According to a United States Consular Report a company capitalized at \$330,000 has been organized in Chile to develop the oil fields in the vicinity of Punta Arenas, in the extreme southern part of Chile, and American boring machinery is arriving for the oil fields south of Concepcion.

Efficiency of Fine Screening Devices

Results of a Series of Experiments With Barren Sand and Ore on Belt Screens of the Callow Type

The following article is abstracted from the Journal of the Canadian Mining Institute, it being part of a paper prepared by J. R. Cox, M. Sc.; G. G. Gibbons, M. Sc., and J. B. Porter, D. Sc., of McGill University, Montreal:

One practical question which has never been solved to the satisfaction of the profession is the determination of the most effective method of preparing fine material for table concentration. Jigs are seldom commercially satisfactory for material finer than ten or, at best twenty, mesh, and as no table can treat the mixed pulp and slime below this size without large losses, it has for years been customary to classify this pulp, more or less accurately, in rising current apparatus or settling boxes, and to feed the roughly graded stuff to two or more tables or series of tables each suitably adjusted for its class of pulp.

This method has had the merit of cheapness and, so long as plain tables such as the Evans buddle were used, this pulp, if reasonably thickened, has been theoretically at least more suitable for concentration than sieved material. Unfortunately, however, classifiers as ordinarily built and operated in mill work are imperfect machines and give only an approximate grading at best, whereas screens although costing more to operate are commonly supposed to do more accurate work; and it has always been a mooted point as to where the reliable sieve should give place to the "unreliable" classifier in preparing pulp for concentration.

The problem has been made more difficult and more important by the comparatively recent introduction of two important types of machines, namely, riffled jerking tables, like the Wilfley, and fine screens, such as the Callow, for wet screening. The latter and equivalent devices, such as impact and vibration screens, have cheapened fine screening, thus making it commercially practicable in many cases to size to 60 mesh or even finer before beginning to classify, and the jerking motion of the Wilfley table has lessened and perhaps completely reversed the advantages of classified as compared with sized feed.

The problem of determining whether to screen or classify table feed is thus seen to be of both theoretical and of practical importance and is therefore particularly interesting to the experimenter. Professor Richards has already worked on it and his results as published* are extremely interesting, but as they seemed to the authors somewhat unconvincing it was decided to carry out a series of tests on a somewhat larger scale in the McGill ore dressing laboratory.

The main purpose of the investigation was to determine if possible the comparative merits of sized, classified and deslimed feed for Wilfley table work; but it was determined to use a genuine ore and a somewhat difficult one rather than an artificial mixture of two pure minerals as in Professor Richards' experiments and it was also decided to work under conditions approaching the practical as nearly as possible.

The work thus resolved itself into

1. A determination of the efficiency, i. e., perfection of operation, of the Callow screen under standard conditions.

Until recent years little screening was done of material finer than about 1 millimeter (.03937 inch) except in connection with stamp milling and other operations not strictly to be considered as concentration. For sizes larger than this, but not too coarse, some form of revolving trommel is most commonly used; but it has not been found economical to employ this type of screen for fine material, on account of the expense of the frequent renewal of the large screen areas employed, and the very low

output consequent upon the blinding of the screens. Material finer than 1 millimeter was therefore generally treated in some form of hydraulic classifier or system of settling tanks. This method is, however, open to the objection that, as ordinarily used at least, the classifier is a less exact and therefore a less reliable machine than a screen; hence, many attempts have been made to evolve a screening machine which would economically take the place of classifiers.

In the quest for a good fine screening machine five general types seem to have been evolved:

1. Screens fixed in a cylindrical or conical frame, the whole revolving upon an axis, usually inclined.

2. Shaking screens:

(a) Horizontal } which may have { (a) parallel } motion.
(b) Inclined } { (b) perpendicular }

3. Vibrating screens, inclined.

4. Screens of the belt type.

5. Conical screens having the feed projected upon the screen surface with some force.

Very little printed information of value is to be found as to the work of these screens. Types 2 and 3 do good work, and with the exception of 2 (a) are free from blinding, but expen-

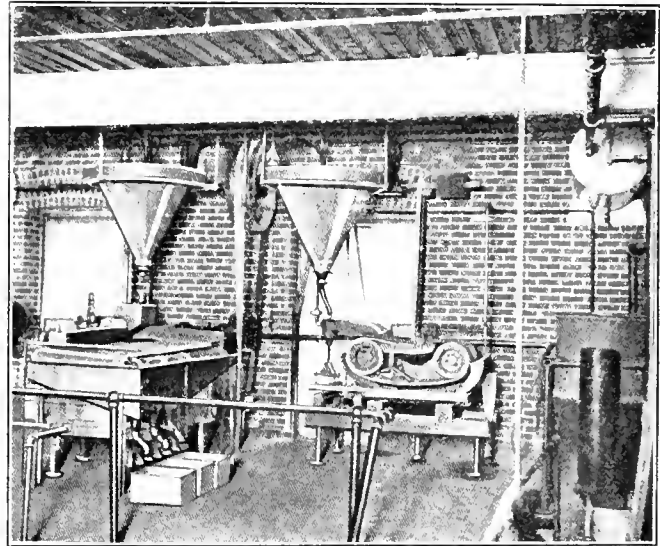

FIG. 1. CALLOW SCREEN, WILFLEY TABLES WITH CONE FEEDERS, SAMPLING DEVICES, ETC., MCGILL UNIVERSITY

sive in upkeep. Types 1 and 5 do not wear out so quickly, but are more apt to blind.

The fourth type does moderately good work, is almost free from blinding, has a large capacity, and the following tests were all carried out on this screen. The machine used was a standard design single 12-inch belt machine and had the Institution of Mining and Metallurgy standard mesh. The machine consists of an endless belt of screen cloth (about 8 feet in circuit and 1 foot wide) edged by rubber lips which prevent the sand from spilling off the screen, and take the strain of driving off the cloth. This belt is carried on two overhung horizontal rollers 1 foot in diameter and travels at from 30 to 120 feet per minute as desired. The sand is distributed across the width of the belt by a slightly sloping feed-sole, and falls in the direction of travel of the belt. A shaking spray near the center of the belt helps to put the undersize through. The oversize is washed off the surface of the belt by another spray as it passes over the tail roller. This machine should have a capacity of rather less than a quarter that of the standard screen, which has two belts each 2 feet wide and slightly longer than this one.

Two series of tests were made: One upon barren sands for the purpose of testing the capacity and efficiency of the screen, and one to prepare ore for the table trials.

*Transactions American Institute of Mining Engineers, Vol. XXXVIII pp. 556-580, and XXXIX, pp. 303-315.

For the first series a considerable quantity of a pure hard nepheline syenite was obtained from the Forsyth quarries at the back of Mount Royal. This was broken in a Comet crusher to a maximum size of about 1 inch and then fed to a 3-foot Huntington mill having an 18-foot discharge screen.

The pulp from the mill before going to the Callow screen was elevated by a centrifugal pump to a small desliming cone which took out the major portion of the slime. A screen analysis of the remaining sand showed the following distribution of sizes:*

	Mesh	Weight Per Cent.
On	20	7.0
On	30	17.2
On	40	8.9
On	60	12.4
On	80	15.2
On	100	3.2
Through	100	37.1
		100.0

The screen, Fig. 1, was fed from a 36-inch 60-degree cone capable of holding about 500 pounds of pulp, which was sent up into the cone by means of a small hydraulic elevator, the surplus water overflowing from the lip of the cone and carrying a small amount of slime with it. The water necessary to operate this elevator amounted to about 18 gallons per minute. This water was fed continuously throughout the test, thus ensuring a constant head, although at the beginning of the test this head would be chiefly of pulp and of high specific gravity, while at the end there would be but a little pulp in the bottom of the cone with water above. Unfortunately this method of feeding involved a certain amount of classification, and the feed at the beginning of

each cone full was generally somewhat coarser than near the end, and the very end of a cone full of sand was always marked by a rush of fines, which unless guarded against, had a noticeable effect upon the run.

The bottom of the cone was provided with a series of interchangeable circular orifices held by grooved side pieces. These orifices varied from 1/4 inch up to 3/4 inch in diameter, the difference between the size being 1-16 inch. So long as the size of the pulp and the head of water in the cone were kept the same, the rate of feed from any one orifice remained practically constant.

So long as any pulp remained in the cone, the rate of feed and the amount of water in the feed-stream were remarkably constant at about 35 per cent. irrespective of the size of the pulp. Any additional water to bring the ratio of water to feed, up to the required figure, was added from a calibrated cock at the head of the feed-sole.

The screen analysis of the sand showed that a 60-mesh screen doing perfect work would pretty evenly divide the feed—there being 55.5 per cent. of the sand through 60 mesh. Hence, a 60-mesh screen was used for the first six runs and the rate of feed, belt speed, and water varied.

Table 1 gives the results of these runs.

Table 2 gives the results of the runs on ore subsequently used for the Wilfley table.

The "capacity" of a screen is the output of material which it will treat in a given period of time, and is irrespective of whether the oversize is well freed from fine material which should have passed through.

The capacities as given by the manufacturers for Callow screens are as follows, assuming a 1:1 feed:

Mesh	Tons—24 Hours Standard Size	Tons—24 Hours Small Size	Pounds—Minute Small Size
20	250	62.5	87.0
30	200	50.0	69.5
40	150	37.5	52.2
60	125	31.2	43.3
100	75	18.7	26.0

TABLE 1. CALLOW SCREEN TESTS (Mount Royal Syenite)

Test No.	Mesh of Screen Used	Undersize in Feed Per Cent. of Feed	Weight Oversize Pounds	Weight Undersize Pounds	Undersize Left in Oversize Per Cent. Oversize	Efficiency Per Cent.	Orifice Inch	Rate of Feed Pounds Per Minute	Belt Speed Feet Per Minute	Water Ratio Dry Feed
Sy. 1	60	55.5	100.0	35.0	40.0	46.7	1/4	17.5	90	3.5
Sy. 2	60	36.4	126.0	44.0	14.1	71.2	1/4	15.9	86	3.6
Sy. 3	60	40.0	110.0	43.0	16.5	69.5	1/4	15.3	86	3.5
Sy. 4	60	39.8	69.0	30.0	15.5	76.3	1/4	14.3	86	3.5
Sy. 5	60	21.4	135.0	21.5	64.5	64.5	1/4	31.5	86	3.5
Sy. 6	60	42.4	124.5	52.2	15.2	69.7	1/4	11.7	86	4.1
Sy. 7	100	35.3	105.0	23.0	13.6	61.5	1/4	10.7	100	4.9

TABLE 2. CALLOW SCREEN TESTS (Bruce Mines Ore)

Test No.	Mesh of Screen Used	Undersize in Feed Per Cent. of Feed	Weight Oversize Pounds	Weight Undersize Pounds	Undersize Left in Oversize Per Cent. Oversize	Efficiency Per Cent.	Orifice Inch	Rate of Feed Pounds Per Minute	Belt Speed Feet Per Minute	Water Ratio Dry Feed
Cu. 1a	100	13.1	58.5	4.4	7.0	51.7	1/4	18.0	100	3.2
Cu. 1b	100	5.2	32.0	3.4	1.7	57.7	1/4	9.4	100	3.2
Cu. 1	100	13.9	1,659.0	183.0	4.4	71.4	1/4	9.0	100	3.2
Cu. 2	60	20.2	1,462.0	181.0	10.3	54.5	1/4	17.7	90	3.8
Cu. 3a	40	34.4	253.0	42.0	23.5	41.6	1/4	26.8	80	3.8
Cu. 3	40	28.8	1,175.0	243.0	14.0	52.6	1/4	22.1	80	3.8
Cu. 4a	30	42.1	131.0	32.7	27.7	47.4	1/4	32.0	80-110	3.8
Cu. 4	30	39.8	911.0	252.0	0	54.3	1/4	25.4	80	3.8
Cu. 5a	20	73.4	112.0	0	0	43.2	1/4	32.0	65	3.4
Cu. 5b	20	76.9	99.0	0	0	50.0	1/4	32.0	95	3.3
Cu. 5	20	74.5	435.0	326.0	55.6	57.4	1/4	23.0	80	3.1

Runs followed by a letter, e. g., Cu. 1a, b, etc., were tests as a guide to determining the best working conditions for each screen. The products of these test runs were mixed and added to the feed for the main run.

*The writer believes that in any system where crushed material is treated on screens, or even in classifiers, it is the better practice first to remove most of the slime. No screen or classifier can be expected to do good work on a feed crowded with slime.

It will be noticed that throughout the tests the capacities obtained averaged about one-third of these amounts. It is possible that the somewhat low efficiencies obtained may be traced to the fact that in all cases the screen cloth used conformed to the standards recently recommended by the Institution of Mining and Metallurgy—that is, the wire used in making the screens is the same size as the space between the wires, so that the percentage of opening is only 25 per cent., whereas the screens ordinarily in use may have a percentage of opening as high as 45 per cent. with a proportionately larger increase in capacity.

The "efficiency" of a screen has been taken as the quantity of undersized material passed through the screen, expressed as a percentage of the amount of undersized material in the screen feed. Thus, a screen which left no undersize material in the oversize, would have 100 per cent. efficiency. The efficiency in this sense is, therefore, irrespective of capacity, and it is conceivable that a machine might have almost perfect efficiency, and still be low in capacity as to be commercially worthless. The true worth of a screen is, therefore, a function of the capacity and efficiency in the sense in which these words are here used.

The factors which affect this efficiency are:

- (1) The thickness of the bed of sands on the screen.
- (2) The time this bed is allowed to remain upon the screen.
- (3) The ratio of the quantities of oversize to undersize.
- (4) The proportion of oversize material which is nearly but not quite small enough to pass through into the undersize.
- (5) The amount of water in the pulp (if wet screening is employed).
- (6) The percentage of opening of the screen employed.

With regard to (1) and (2) it is obvious that the thinner the bed the quicker the screening will be done and the greater will be the efficiency, but the smaller the capacity.

A consideration of (3) illustrates the weakness already referred to in the use of the above definition of efficiency as a means of judging the usefulness of the work done by the screen. Take for instance two lots of sand of say 100 pounds each, and assume that screen analyses show that lot 1 has 20 per cent. and lot 2 has 60 per cent. of particles below a certain screen size, say 60 mesh. These lots are then screened on the same 60-mesh screen under conditions such that the efficiency is the same—say 75 per cent in both cases. The undersize remaining in the oversize after the screening will in the case of lot 1 amount to $(20 - \frac{75}{100} \text{ of } 20) = 5$ pounds, or 5.88 per cent. of the "oversize" produced. In the case of lot 2, it will be $(60 - \frac{75}{100} \text{ of } 60) = 15$ pounds, or 27.3 per cent. In each case the efficiency is the same, yet there is a difference of over 20 per cent. in the percentage of undersize left in the "oversize," a fact which must be borne in mind when comparing the work of different screens.

With reference to (4) it is obvious that grains which will just fail to pass through a screen are much more likely to blind it and thus reduce its capacity than coarser material, and in this connection it might be remarked that some types of screens become blinded more readily than others and, therefore, are particularly ill suited for material of this character.

Both theoretical consideration and practical experiment seem to show (5) that up to the point when a screen begins to get flooded it will do more and better work the more water is used.

The best screening (6) will naturally be done with wire cloth having a large per cent. of opening, i. e., made of fine wire; but such screens wear out quickly and their meshes are also likely to become deformed. On the other hand, it is possible that the standard of 25 per cent. opening, adopted by the Institute of Mining and Metallurgy, may give a needlessly substantial screen in the coarser sizes, and that for commercial purposes cloth made of finer wire, but with the same clear openings, may be more economical.

Commenting upon the runs individually it will be noticed that the efficiency of Sy. 1, Table 1, is only 46.7 per cent. This is in part due to the larger proportion of fines in the feed (55.5 per cent.) and in part to a rush of fines at the end of the run, some of which in consequence got carried over into the oversize. In the rest of the tests in Table 1 the run was always stopped before the sand in the feed cone got too low.

Tests Sy. 2, 3 and 4 show the influence of varying the ratio of feedwater to feed. With a ratio of 3.8 we got an efficiency of 71.2 per cent. By almost doubling this ratio (90 per cent. to 7.8), we got an increase of efficiency of only 7 per cent. to 76.2 per cent (5 per cent. absolute), with lower capacity.

In Sy. 5 the rate of feed was doubled with a decrease in efficiency of only 6.7 from Sy. 2. It will be noted, however, that the per cent. of fines in the feed was much less—21.4 instead of 36.4 in Sy. 2.

In Sy. 6 the reduction of the feed to only 11.8 pounds per minute failed to give a very good efficiency.

Sy. 7 was run to get an idea of the working of the No. 100 screen before starting to prepare the copper ore for the Wilfley table.

Table 2 shows the results of the runs on this copper ore. With the exception of Cu. 1 the efficiencies are lower than in Table 1, chiefly on account of the large amounts of undersize in the respective feeds, especially in the coarser sizes. Furthermore, the runs reported in this table had to be carried to the very end of the feed, with the consequent rush of fines at the end.

It will be noticed that the ratio of water to feed is largest with the fine screens and smallest for the coarse screens. It was found to be impossible to keep the ratio much higher than 3:1 with the coarse screens without flooding them.

Runs Cu. 5 (a) and (b) show the effect of varying the

speed of the belt. The increase of speed from 65 to 95 feet per minute, thus giving a thinner bed of pulp upon the screen, increases the efficiency from 43.2 to 50 per cent. It would seem advisable, therefore, to use only high speeds, but it has been found in practice that high speeds wear out the belts too quickly, because of the greater strain on the cloth and the rapid bending and unbending of the mesh as it passes over the rollers. It is a great deal owing to this bending of the mesh that the Callow screen is so free from blinding. Any grains that may have stuck in the openings are loosened by the bending of the cloth and are at once washed off by the cleansing spray opposite the end of the roller.

The feed-sole, which is fan shaped, gives a very even distribution of the feed over the belt, and during the course of the 2-inch drop from the lip of the feed-sole to the surface of the screen a certain amount of separation takes place between the large and small grains which help the screening action very considerably. The large grains, owing to their greater momentum, have a slightly flatter trajectory on leaving the lip of the feed-sole than have the smaller grains; consequently the large grains strike the screen a little in front of the small grains.

These latter, unhindered by large grains, immediately pass through the screen. This idea is borne out by the fact that the screening action is practically completed in the first inch after the feed-stream strikes the screen. The shaking spray seems to put through very little undersize, although it no doubt forces through some grains or loosens up others which have caught in the mesh.

In general the belt screen may be said to show reasonable efficiency and large capacity. Screen cloth of the Institute of Mines and Metallurgy standards may not, however, prove economical to use with screening machines of this type for reasons already given, and the belt speed should be as high as is possible without excessive screen renewals. It is also very desirable to use some form of dewatering device before screening in most cases.

栗 栗

Auric Hydroxide

The compound formed on a gold anode consists of auric hydroxide with about three molecules of water. If potassium sulphate (K_2SO_4) is used as the electrolyte, the deposit contains potassium, probably as potassium gold hydroxide ($KH.Au_2O_3$). The auric hydroxide deposit is translucent, ruby red, and apparently crystalline. When either auric hydroxide from the anode, or the amorphous form, obtained by the hydrolysis of auric nitrate or sulphate, is heated, it gradually loses water up to 172 degrees but does not become anhydrous at 200-210 degrees. At temperatures above 172 degrees the compound slowly gives off oxygen but does not yield auroauric oxide (Au_2O_2) as stated by Kruss, or auric oxide (Au_2O_3) as indicated by Schottlander. When auric hydroxide is treated with hydrogen peroxide or a solution of sodium peroxide, it is reduced to the metal. The deposit formed on a gold anode in the presence of ammonium carbonate contains a fulminate.—H. S. Winter, *Journal American Chemical Society*, 1911, 33, 688.

栗 栗

Gold Mining in Siberian District

According to the statistics of the Priamur mining inspector, furnished by Consul Lester Maynard, of Vladivostok, 17 gold mines were being operated in the Amgun mining district of Siberia. These mines include 40 claims and produced 27,595 ounces troy of gold. There were 831 Russians and 4,146 Chinese laborers employed, and in all about 500,000 tons of gravel were washed. The total sum paid for labor amounted to \$186,856. In addition to the above, 150 Russians and 2,566 Chinese worked on these claims on a percentage basis and from 12 mines produced 21,312 ounces troy of gold, the total value of their share being \$178,503. These figures do not include gold illegally obtained by Chinese and exported to China.

Fundamentals in Technical Education

Illustrations, From Practical Experience, of Errors Arising From the Blind Use of Formulas

By Regis Chauvenet*

Young practitioners who have been well grounded in mathematics, and have been taught the derivation as well as the use of formulas, will naturally discriminate between those of an invariant character, and those which demand some investigation for the values of certain constants. To coin a "bull" we sometimes have what we may call "variable constants."

We remarked before on the danger of "letting the mind rest" in certain definitions, regarding them as finalities, and as expositions of all we know as to their subjects, instead of looking at them merely as delimitations.

Take a common definition of the chemical "atom," viz., "the least portion of an element which can take part in a chemical reaction." We hardly believe today that we know no more than that about an atom. But we do not attempt to drag all we know, or think we know, about it into its definition.

Some danger lurks also in the unintelligent use of a formula. Grave errors have been made by assuming the value of a constant which some consideration of the conditions would have shown not to be accurately known, and which might require a careful investigation to determine, under the special limitations imposed.

When the Wright brothers started their classical research, resulting in the epoch-making aeroplane, they discovered that certain formulas as to the action of air impact upon inclined planes were not available as working factors in their calculations. We are not going into any of the complexities of this interesting topic further than to point out that, had they stopped at the formula and not added the wonderful combination of brains, patience, and faith that led to ultimate success, there might be no biplane today. It is true, of course, that the problem of a moving and sensitive plane has elements differing from impact on a rigid surface, but the question required the experimental genius of the brothers for its solution. Here we are on dangerous ground, and liable, indeed, to literally "get up in the air," and we turn to more homely illustrations.

Our first case is not far from a practical joke, albeit an actual occurrence. We shall not dignify it as a "formulistic" problem. We have in mind a rather ludicrous event of several years ago, the engineering enterprise on foot being nothing more than the erection of a "grand stand," we forget for what sort of an open-air event.

A sketch or plan had been furnished, and the carpenters, who were a very "amateurish" lot, proceeded to cut out and frame up the structure. Their plan seems not to have included any specifications as to nails.

It was evident, however, that many nails were called for. How many, and where did they go? One of them remembered a "rule," viz., that one nail would carry 100 pounds weight. That looked rather easy, and a very simple computation yielded what we may call a formula. After measuring the seating capacity, and the average supposed weight of a spectator, they arrived, whether formally or not, at the obvious formula:

$$\frac{W}{100} = x$$

In which, as the books say, W = total weight and x = number of nails.

Up went the grand stand—and down, too, for it gave way with a majestic sag soon after the exercises opened. Fortunately (for it was not a towering structure) there was no loss of life. Whether the 100-pound rule specified the size of the nails we are

unable to state. Probably it did *not* specify any method of distribution so as to meet stress with resistance at the proper points.

We believe there is a moral to this, but we have mislaid our reference. We ask our readers to look one up, while reading this little anecdote of the celebrated English artist, Turner:

"Pray, Mr. Turner," asked a self-sufficient youngster who aspired to join the ranks of English painters, "how do you mix your colors?" "With brains, sir," was the answer.

We have excluded all but the most elementary mathematics from this paper, and refrain from giving cases of the blind use of formulas in mechanics.

Chemistry furnishes our next example. We hesitate in giving the following, for fear of being accused of deliberate fiction. However, we certainly have not imagination enough to have concocted so improbable a yarn, which unlike most yarns is statistically true.

The "chlorination" process in the metallurgy of gold is well known today, the chlorine being evolved, in the barrel carrying the pulp or ground ore, with water and the addition of the chemicals for the evolution of the gas. The chemicals are chloride of lime, so called, and sulphuric acid. The equation is:

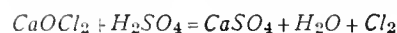

In the mill in question, the chemist was asked to investigate the solution as drawn off, which was not acting properly, and he reported a deficit in the sulphuric acid, at the same time stating the necessary addition to the charge to straighten out the reaction. The superintendent reported that the change had been made accordingly.

But the next batch was as bad as ever, viz., same deficit and same failure in extraction. Investigation was next in order, when the amazing fact was developed that though the proper increase of acid had really been added, *the lime salt had been increased in the same proportion*. So tied down to a rule was this individual that he couldn't get away, and having no glimmer of chemical knowledge he did not even understand the significance of the chemist's report. Answering a question which hasn't been put, but which well might be, we add that he owed his appointment to a man who knew a little less chemistry than he did, i. e., "a little less than nothing."

Another possible question: "What does this illustrate?"

It illustrates stupid adherence to a rule when a little (very little) knowledge would have shown that the rule no longer applied. Also, it illustrates the danger of ignorance and the "sense" of having men drilled in the elements of a science before being called on to handle them.

We confess that we go far back in time for our next illustration, but we know some men nearly as ignorant who are "in the field" today in similar or parallel lines. The case was that of a smelting concern, running, or trying to, on the lines so long followed at Argo, Colo. We were going through the plant with its superintendent. We had already had one snub, for on asking him for the analysis of some material he had answered curtly: "I've no use for an analysis." Presently our attention was attracted to a pile of mill tailings, waiting to be charged on to a reverberatory hearth. It looked remarkably siliceous, say 85 per cent. for a guess.

"You add something for flux to this?" we said tentatively.

"I do *not*." (Curt and sneering.)

"How can you melt it by itself?"

"I'll tell you." (This with an air of instruction to the densely ignorant.) "If a ton of coal doesn't melt it, I'll take two, and if two doesn't melt it, I'll take four."

We had often heard of "muscular" metallurgy. Now we saw it. The works were shortly afterward sold out. The backers of the enterprise whose direction was under this anachronism were men wholly ignorant of scientific metallurgy, and it was said that they gloried in the fact, and alluded to their superintendent as a "self-made" man. That, of course, before the crash that

* Mining Engineer, Denver, Colo. First article on this subject appeared in April number.

presently overwhelmed them. In this particular, the process, which was in part probably pirated from another works, was in the main a correct one, in principle. It was discovered, too late, that even a good process requires "brains" to run it. If the man in charge really has brains but lacks the necessary knowledge it is fairly certain that he will soon "know enough to know that he doesn't know enough."

We have rendered our tribute of admiration to the men who have overcome the handicap of deficient education. We have now to render tribute to another kind of man still in evidence at times, who is not in any sense a "success" unless it may be that he "promoted" something and pocketed a fat commission, but who is fond of alluding to himself as "self-made." We admire a "self-made" man until he reminds us of the fact himself.

"I'm a self-made man," said one of the more effusive of the tribe, to Horace Greeley.

The philosopher of the *Tribune* looked him over, and in his high pitched drawl settled his case in a phrase: "That," he said, "relieves the Almighty of a great responsibility!"

It is a pity that the case of the famous "Keely" motor should have made so little impression on the country. It was really a fine object lesson, but the world laughed and forgot it. For a generation this singular and almost unique fraud was proclaimed as the greatest discovery of the age. It was a new source of power. Under the control of the machine, or "motor," a teaspoonful of water (without fuel) would run a train from New York to Philadelphia. Many examined the "motor" and many "examined" Mr. Keely. His "science" did not pass muster, but that was nothing to his admirers, for they accepted the explanation of Mr. K himself, which was that *his* science was so far ahead of all other science that there wasn't a man living who could understand or follow him!

Often he would proclaim that the obstacles were all removed and the machine was about to operate. On one of these occasions the announcement was made, with more than the usual flourish, and he told his stockholders that it now remained only to "focalize the vibrators" and then the great work was over! Weeks passed. Nothing happened. The *New York Nation*, which had always seen through the fraudulent character of the whole business, sarcastically suggested to Mr. Keely that since "focalizing the vibrators" didn't seem to work, how would it do to "vibrate the focalizers?"

How much money went into this thing no one can tell. Many thousands certainly. It is another case sadly illustrating how little all our scientific education has impressed the world at large. Keely died, and the great machine proved, when dissected, to be a sorry fraud, with the old, old trick of a hidden wire, running through a table leg or some equally transparent device, for running the wheels or "vibrators" by means of power in an adjoining room. As bad as "Katy King" and her materializations.

Poor fellows (we mean the stockholders), they hadn't any "fundamentals." Keely had—but of another kind.

But why need we go to a past generation for a "frightful example?" Have we not "always with us" enough cases of bogus metallurgy, which belong quite as fitly to our theme? They belong "by contraries." Technical education is not responsible for them, but the lack of it is.

That vague entity, "the public," sometimes called the "world at large" (terms often used, by the way, in such a way as to leave very little meaning in them), is in need itself of a considerable technical training. This it cannot get in a direct sense. Perhaps it hardly needs it, but it would be a boon inestimable in value to that other entity, the "investing public," if it could be induced to so far go into the schemes submitted to it, as to recognize who are and who are not competent guides in respect to new enterprises whose bases are ostensibly technical.

Unfortunately there is abroad a certain spirit of antagonism to anything which has been dubbed "scientific." When we say "it is abroad" we do not mean that it is the prevalent or majority

opposition. It is a class opposition, but the class is well defined. Hardly any one but that has met with its exponents.

Who has not heard this kind of talk?

"I tell you sir, *gold is where you find it*. I believe in the old practical miner etc., etc."

So do we. We believe thoroughly in the old miner. We couldn't get along without the old miner. What our friend just quoted really means, however, and is trying to convey, is that no one but the old miner knows anything at all. Say, the old miner has told him that "it always gets richer as you go down," and he will not only believe the oft-told lie, but will put money into its backing.

Men of this class, who, although a minority, are numerous, are partly the victims of their own false ideas or definitions. Try this experiment the next time you hear "science" mentioned with a sneer, viz., ask the speaker to define "science." You will get one of two things, viz., either a complete failure to present anything intelligible, or a definition showing about as much knowledge of what science means as a hen would show about navigation.

The bogus metallurgist, then, would never flourish if his clients had knowledge enough, we do not say to investigate for themselves, but enough to know to whom to apply for a verdict reasonably certain to be correct.

So numerous have been the schemes of the past 40 years, in this line, that it is not probable that any one man could keep track of all of them. We shall mention a few; doubtless many who read this will recognize some old friends, and many others could help us swell the list:

We have had, then, a project for extracting gold from its ores by "centrifugal force," the "pulp" being whirled in the machine, which sent the barren rock flying off in one direction while the gold remained behind—or perhaps it was vice versa, we don't remember. It appears that the victim who sunk two hundred thousand in this queer humbug was chiefly influenced by the fact that it was laughed at by all "scientific metallurgists." Therefore (get out your microscopes and look for the logic) it was bound to work.

A project for heating finely ground ore to such an intense degree that it would be dissipated not only into vapor, but actually disassociated into its "atoms." Then these "atoms," each having its own particular temperature for condensation, would condense successively, each at its own little place in the long cooling tube provided for that purpose. Tap here, you get the gold, and here the copper, and so on throughout. Of all the metallurgical "schemes" we have examined, this is the broadest in principle, but the inventor made one error, viz., in location. He chose the earth, he should have gone to the sun, where such temperatures may be cheaply obtained.

A scheme for roasting ores by excluding air instead of admitting it. That wasn't what he called it, but the practical intent of the invention was just that, as was apparent to any one who took the trouble to examine it. This scheme has been pushed in several cities in the United States, and in one instance we learn works were actually erected on a small scale.

Several schemes for getting far more metal out of an ore than the most rigorous assay showed it to contain. This is the form that alchemy takes at the present day. The process, so far as its claimed results are concerned, is venerable. The language, too, is almost a replica of that used by the alchemists. The "growth" of the gold. The "oil of gold." The "volatilization" of the gold by ordinary assay methods. The "forms of gold" not recognized by modern science and all the other hodge-podge addressed to ignorance. This is repeated over and over. But few persons read the publications of more than one fakir, or one generation, and fail to see that they are all the "same old coon" in variant disguises.

In vain will science expose frauds of this kind. So long as the deadly alliance of ignorance with the get-rich-quick idea can

be made, so long will some swindler come to the front, skilful enough with tongue to beguile the dupes, trained enough in judgment of human kind to select the proper fools for exploitation.

A scheme for the extraction of gold from sea water. Here the "joke" is on staid old New England. Never lived a more skilful manipulator than the inventor of that wonderful process that took shape in the formation of the "Electrolytic Salts Mfg. Co." Plausible as no man before was ever plausible, he acknowledged that the amount of gold was so small as not to be recoverable by any known method, so he proposed to use nature's force of the tides and so get away from all power expenses. The Bay of Fundy was chosen, for its high tides are well known. Thus, he got his sea water by tidal action, and its outflow after extraction of the gold served for such power as might be needed. And the mill was really built! Herein this fraud differed from most of its genus. And the company declared a dividend! Herein it did not differ, for the trick of making a dividend out of money sent in by dupes is a very old one. But presently the inventor-promoter-manager "skipped." It is said he was traced to some foreign country and captured. The unhappy stockholders, of course, took possession of the "mill" and finding after a trial or two that no gold could be extracted, wisely dissolved the corporation.

We might recall others, but we shall take pity on our readers. We should not be surprised to hear that a company had been formed for the extraction of sunbeams from cucumbers, of oil from granite, or of anything else from anything whatever; since we have read of the "soluble gold spring" of California, and the fact that its purchase, as such, was seriously negotiated, in spite of the fact that *no chemist in the state could discover a trace of gold in the water*. But the "discoverer" explained that the gold was manifest only to his own occult method of testing—and all was serene again!

We may class all of these promotions under more general heads, e. g.:

For the transfer of dollars from granger to promoter.

For absorbing money from him who is captured by big words he doesn't understand.

For the exploitation of such idiots as believe that processes are to be valued *inversely* as the science, experience, and hard work that have gone into their development.

For the furtherance of all methods of flattering a fool by making him believe that his folly is better than other men's wisdom.

We do not expect that any extension of technical education, whether through university, technical college, or correspondence school, can put an end to the fool crop. But let us not stop trying. A few years ago the extermination, even locally, of the fever-bearing mosquito was deemed a chimerical enterprise. Today the yellow fever is a vanishing factor.

We exterminate the mosquito by preventing his birth. How can we prevent the birth of fools? Bret Harte has answered in his parody on Victor Hugo: "Educate your grandmother."

We may hope that in some future generation fools will have become so rare as to be classed as freaks. Let us not attempt their extermination by murder, but by the gentle process of natural evolution. Gladly do we leave the details of our scheme to be worked out by the generations most to be benefited.

We have treated this subtopic as though it were something of a joke, but those who have lost their thousands would, we think, have but a feeble smile for it. We take up now a few more actual cases. Those of our student readers, who have taken up chemistry, may get a lesson in practical stoichiometry from our next illustration. This, by the way is the latest in date of any case selected, coming to the writer's attention in the autumn of 1911. It is rather trivial, but is included because very illustrative of what we mean by "fundamental" knowledge.

A blende was being roasted, and very perfectly roasted, too, in a modern and well-equipped works. To simplify the figures a

little, we shall say that it went to the roasting hearth containing 90 per cent. of zinc sulphide and 10 per cent. of impurities. That would mean 60.3 per cent. of metallic zinc.

It is well known that ZnS thus treated passes by oxidation partly to oxide and partly to sulphate, the latter ultimately, by higher heat, losing its SO_3 and passing also to oxide, the latter being, theoretically at least, the only form of zinc compound going from hearth to retort.



The superintendent of the works remarked that the roast was extraordinarily "sweet" (i. e., free from ZnS), in fact, they could not detect any "sparklers" by the eye. "But," he added, "we have no quick way of getting at the proportion of sulphate left: it takes too long to make the sulphuric-acid determination."

"Why not titrate for zinc?" we asked, "that would take but a few minutes."

"Zinc isn't the question. We want to know the zinc oxide and zinc sulphate."

The boss, by the way, was his own chemist, and knew perfectly well how to make any necessary assays or ordinary analyses. We showed him that the zinc determination was sufficient to give good working figures on the proportion of oxide and sulphate present, and as this is rather a pretty little problem in stoichiometry, we give it here, assuming the data as above. This, of course, is for the benefit of the student who may happen to read this paper. Let us assume that the "roast" is quite free from ZnS . Also, as above, that we had 10 per cent. impurities originally. Now let the material on the hearth assay 45 per cent. zinc. How much zinc oxide and how much zinc sulphate does it contain?

1. Work on basis of 100 pounds material. If 45 per cent. of the product is zinc, then the 100 pounds originally charged must be now:

$$\frac{60.3}{45} \times 100 \text{ or } 134 \text{ lbs.}$$

The increase of weight is due to the sulphate. Now if there has been no loss by volatilization, this will serve as the basis for computing the percentages, as below.

2. $ZnSO_4$ contains 40.37 per cent. zinc, while ZnO contains 80.25 per cent. If x = pounds of $ZnSO_4$, then:

$$.4037x + .8025(124 - x) = 60.3$$

(N. B. 124, because 10 pounds of the 134 is impurity.)

$$x = 98.3 = ZnSO_4, \text{ and } 124 - x = 25.7 = ZnO$$

We leave the proof to the reader.

Difficult? No. But fundamental. It is an application of elementary principles of chemistry, really nothing more when analyzed than a comparison of molecular weights. The "mathematics," an equation of the first degree that many boys of fourteen would be ashamed to call a problem. But it is not a question of knowing these details of solution. It is a question of whether the first principles have been acquired in the true "fundamental" sense. If they have, the rest follows.

The boss wrote to me the next week asking for a table showing the actual percentages of each compound for each per cent. of zinc found. This was another revelation of his lack of fundamental knowledge: he was asking for the impossible! Unless you know the per cent. of impurity, you have not the data for answering the question, or for making up the table. However, we sent him half a dozen tables, each for a probable percentage of impurity, and we hope he is happy. Observe, he was perfectly competent to make the assays required, what he lacked was knowledge of a different kind.

It is not uncommon, in chemical lines, to find a considerable knowledge of detail with defective foundations. We have given an instance in the combustion of gases. We have frequently found that the numerical relations of interacting bodies (stoichiometry) is poorly or not at all developed in chemical courses. Yet it is of more practical bearing than a hundred details that are

usual requirements. The writer has often been surprised to find persons of supposed chemical knowledge "stumped" by questions that should not have presented the least difficulty. A mere appeal to first principles would have "turned the trick." But it was precisely these that were wanting.

It would be easy to multiply examples like these, indeed examples really better suited to our argument, but the best illustrations are not the simplest, and involve complexities which would be out of place in a general article.

We have heard of the supposed fact that the graduate has to "begin at the beginning" just like those who have not had his advantages. We have very many times seen cases *not* in point. However, there are superintendents who not only refuse to credit a graduate with any knowledge of utility, but who will go out of the way to throw difficulties in his way, and are always on the *qui vivé* to make a point against him. This is too common to have escaped the observation of any one who has seen the *modus operandi* of a boss with a prejudice against education.

Let us accept, as a "parable," two young men of equal age and equal abilities, one technically educated, the other a "scientific illiterate." Which of the two will the better grasp the higher lines of the profession?

This has been so often answered by experience that it is no longer a question. If, however, one should assert that the untrained youth will do better, or as well as the other, such a person will class himself with the fireman who asserted that he could raise steam quicker from cold than from hot water.

We return now to the elements, back of technical instruction to the High School; back of the High School to the "grades." The instruction is usually by teachers who have themselves no firm grasp of scientific fundamentals. If they have them, they have little chance to properly instruct, overcome by the lack of time and the excess of numbers. It is not easy to hold the attention of children (6 to 14) to the spoken elucidation of principles. It is difficult for children to conceive that anybody can know more than "the book!"

The obstacles (partly inevitable) in primary and secondary education lie on both sides, *viz.*, system and pupil. If these early grades are no portion of technical training, they certainly constitute a foundation for it. If we cannot apply the remedy at this early stage, we may at least indicate how to correct the defects when the student passes from the High School or its equivalent to the higher lines.

Let the instructor then consider what are the probable defects in scientific apprehension of the newcomer, and instead of taking his slips as signs of stupidity or laziness, let him rather view them as generic. Review the elements, with broader foundations, more suited to greater age. The reasoning powers are little developed before fourteen or fifteen—"youthful prodigies" aside, and we are not considering such. We demand of the instructors of the first or lower classes in the professional school that they remember that pupils of the age just stated cannot be expected to originate in science or to show much power in applying principles to problems.

Here a chorus of teachers interrupts me: "We can show you hundreds of pupils of that age, and under fourteen, who can do just that. They have gone into decimals, they have solved equations." * * *

Yes. We've had them by dozens and scores. Nor are we trying to minimize what has been done for them, nor what they have done. We are asking of them no more than what is normal to their age and natural mental development. What they really can do is to carry out set rules and show that they have good memories.

If the system under which the teacher has been working is itself unscientific, she is hardly responsible for it, and as for the pupil it may be doubted whether much more could be expected of him, trained as he has been in too many lines ("multiplicity") and hardly passed "childhood" in very many cases.

There is a hiatus almost painful between the secondary and the technical school. We admit, here as elsewhere, great differences both in institution and in individual. We can only state the usual or average experience.

We repeat, then, that it is the duty of the instructor in the earlier stages of technical work to broaden the view of the freshman, to which end it is no waste of time to go over the ground in topics in which he has passed in the lower school. Do not "kick him down stairs" for his credentials, but go down stairs yourself and help him up.

It may not be amiss, since we have gone down to grades preparatory to the technical, to illustrate, by example, something of the class of misapprehensions into which boys from the lower grades may fall. Here is one which would not be quoted were it not that the lad afterward showed real proficiency and originality. He came to us in trouble, his complaint being that he was being made to work in a class whose work he knew by heart already. (This was probably true. He *did* know it by heart, and he knew it in no other way.)

In the course of the discussion it suddenly developed that although he was well aware that:

$$(a + b)^2 = a^2 + 2ab + b^2$$

yet he did *not* know that the square of two-plus-three was equal to the square of two plus twice the product of two by three, plus the square of three!

$$5^2 = 2^2 + 2 \times 2 \times 3 + 3^2 = 25$$

In short, there was no real meaning to him in the first statement, nor in any similar one. Yet here he was, the graduate of a High School, and Freshman in a technical institution, pitifully ignorant of his first principles of algebra, and actually complaining because he was being compelled to take instruction in a subject he knew nothing about.

We would say something just here again about "fundamentals," but we feel that we have worked the word too hard already, and we shall now give it a rest.

There is an ever increasing tendency to multiply appliances and machinery in our technical institutions. The question whether this is an unmixed good is interesting; we shall dismiss it as somewhat out of the line of our article. We have only this to say: too many such appliances there cannot be, unless their use and illustration becomes so time consuming that they interfere with groundwork in principles. Better in such a case to trust after experience in practice, than to crowd in preparatory practice at the expense of true foundational knowledge.

As this is not a controversial paper, we shall not discuss the relative merits of the "correspondence" school and the "regular" institution or department. We are too firmly convinced that each has its function, to set up any comparison. Rivalry is hardly possible between them, unless the claim is set up by one of the two that it alone can supply the demand. We do not think any such exclusive claim is being made. The success of the correspondence schools has been too pronounced to be denied.

In the very nature of the two, it is more in the line of the "institution" to lay scientific foundations. As for the other system, nearly every student in it, as we have previously remarked, comes to it with a sense of "something lacking" and with mature years. Hence an advantage in actual operation. A hungry man does more justice to his repast than a full one.

In addition to the foundational advantages of the "institution," we have a more logical sequence of subjects, for the student rarely selects this for himself with much judgment. Personal contact with instructors is another point of value. Greatest of all is the equipment of a well-furnished institution, especially in geology and mineralogy, chemistry, and testing plant.

The equipment of the student in the correspondence school may be that of the establishment in which he is employed. In such a case it may be a better illustration of one line than its corresponding appliances in the "institution." Broadly, however, the established institution is better in this respect than the "field."

Neither system can be said to have settled into its final lines. In this ever-expanding field, there may be no "final lines!"

We criticized the critics of technical institutions, in the earlier part of this series, for asserting that it did not accomplish certain things that it was never meant to accomplish. If the correspondence school does not meet every requirement of every profession and every individual, it is hardly fair to charge it with that as a defect. It hardly makes any such claim.

Enough has been said to show that ground work is the prime necessity. A few things mastered, fundamentals firmly embedded in the mind, the rest will come. Plow and fertilize your field, then, whatever seed may be afterward sown, it will flourish, nature willing, man helping.

采 采

Trade Notices

Roberts & Schaefer Co. Move.—On account of increase in business, Roberts & Schaefer Co., consulting engineers and contractors for coal mining, washing, and briquetting plants, have moved their offices to the top floor of the McCormick Bldg., Van Buren Street and Michigan Boulevard, Chicago.

Roller Bearings for Mine Cars.—The Hyatt Roller Bearing Co., of Newark, N. J., has issued a booklet illustrating 12 standard makes of mine car wheels now equipped with the Hyatt type of roller bearing. Each make of wheel is illustrated in cross-section, showing the details of its construction and a brief but comprehensive description of each type is also given. The information contained in this booklet should be of interest and value to any mine operator or superintendent.

The Chain Vise.—The general success attending the manufacture and sale of the original "Vulcan" chain vise has led the manufacturers to increase this line of product, which now, with the added sizes, will care for all pipe sizes from $\frac{1}{2}$ -inch to 8-inch diameter. They are made in three sizes as follows: No. 1 (Baby) capacity for $\frac{1}{8}$ to 2 inches; No. 2 (Original) capacity for $\frac{1}{4}$ to 4 inches; No. 4 capacity for $\frac{3}{4}$ to 8 inches. The smallest size (No. 1) is manufactured with an added improvement enabling the extreme of chain grip without bending or injuring the smallest pipe.

Electric Mining Equipment.—The Copper Range Consolidated Co., Houghton, Mich., has added to its present equipment five new 4-ton electric trolley mining locomotives. The Bartlesville Zinc Co., Collinsville, Okla., will extend its electrical equipment by installing one 100-kilowatt turbogenerator set, one 25-kilowatt motor generator set, two 50-horsepower motors, one 25-horsepower motor, one 75-horsepower motor and a switchboard. The Benson Mines Co. will install at its iron mines at Benson Mines, N. Y., a complete new equipment of electrical apparatus to supply power both for crushing and grinding, comprising two 437-kva. waterwheel type generators, two 12-kilowatt generators, six 300-kva. transformers, one 450-kva. generator, one 12-kilowatt generator and sixteen motors ranging from 5 to 200 horsepower. All of the above apparatus will be supplied by the General Electric Co.

Removal of Ricketts & Banks.—On May 1 Messrs. Ricketts & Banks, mining, metallurgical, and chemical engineers, moved their offices and laboratories to Maiden Lane Bldg., 80 Maiden Lane, New York City. They have a complete testing plant for determining method of ore treatment, also laboratories for research work and testing of processes, and make analyses of all materials and products. They also examine mines and properties, and advise as to development and operation.

The H. W. Johns-Manville Co.—The executive offices and New York show rooms of the H. W. Johns-Manville Co. were moved on April 20 to the new twelve-story "H. W. Johns-Manville Building," Madison Avenue and Forty-first Street, New York City, from their old quarters at 100 William Street, where they have been located for the past 15 years. This move marks

the 54th anniversary of the company. Under the name of H. W. Johns Co., the business was conducted at 87 Maiden Lane, previous to May 1, 1897, when it was moved to 100 William Street. In 1901 the firm name was changed to H. W. Johns-Manville Co., a consolidation being effected between the Manville Covering Co., of Milwaukee, Wis., and H. W. Johns Mfg. Co. This last combination brought together two of the largest manufacturers of pipe and boiler coverings, packings, roofings, etc., in the world, and the growth of the company since that time has been remarkable. In the new quarters the company will have the distinction of being one of the few manufacturing concerns which occupy an entire twelve-story office building.

Forced Draft.—The American Blower Co. has installed "Sirocco" blowers in many places where large quantities of air under moderate pressures are required. In the two battleships "Utah" and "Florida," recently accepted by the United States Government, 12 of these fans were installed to furnish forced draft for the boilers. The wheel of each of these blowers is only 33 inches in diameter, but is capable of delivering 28,500 cubic feet of air per minute, or 342,000 cubic feet for the 12 running together. The installation is very successful.

采 采

A Convenient Burette Stand

A very convenient and inexpensive burette stand may be made as follows: Take an ordinary 5-pint acid bottle and a rubber stopper with two holes. Bend a glass tube as shown in the cut so it will reach nearly to the bottom of the bottle while the upper end will discharge into the burette. Take a shorter piece of tubing and bend at right angles and provide it with a short piece of rubber tubing. Insert these tubes into the rubber stopper as shown. Now take a burette clamp and clamp the end intended for the burette around the neck of the bottle and clamp the burette on the other end, which is intended for an iron post, but will just fit an ordinary burette.

In operation, the bottle is filled with the standard solution. Take the short rubber tube in the hand and blow into it. Pinching

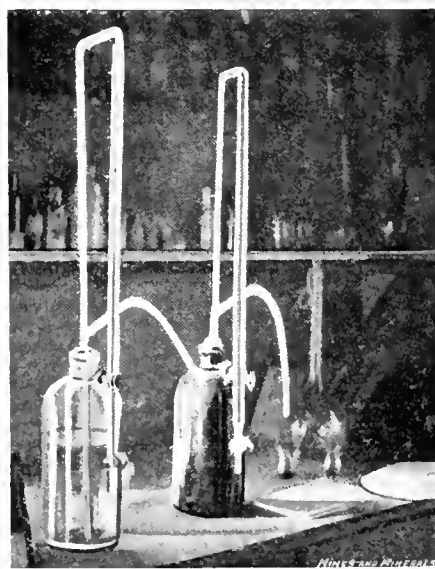

BURETTE STAND

the tube with the fingers so soon as the liquid rises. When the liquid reaches the 0 mark of the burette it can be stopped by releasing the rubber tube.

This apparatus will be found very convenient, especially where it is necessary to make determinations at different points, as the whole thing is self-contained except the indicator and spot plate. —E. W. B.

Mines and Minerals

Vol. XXXII—No. 12.

SCRANTON, PA.—JULY, 1912—DENVER, COLO.

Price, 25 Cents

PUBLISHED MONTHLY AT SCRANTON, PA.

ESTABLISHED 1881

INTERNATIONAL TEXTBOOK CO., PUBLISHERS

T. J. FOSTER, President S. P. ALLEN, Secretary E. H. LAWALL, Treasurer

RUFUS J. FOSTER, Vice-President and Manager

EUGENE B. WILSON, Editor ARTHUR J. HOSKIN, Associate Editor

WESTERN EDITORIAL OFFICE: 1221-1222 First Nat'l Bank Bldg., Denver, Colo.

CHICAGO OFFICE: 1006 Michigan Ave.

Entered at the Post Office at Scranton, Pa., as second-class matter

Address all business communications to MINES AND MINERALS, Scranton, Pa.

CABLE ADDRESS, "RETSCOF, SCRANTON"

LONDON OFFICE: INTERNATIONAL BUILDINGS, KINGSWAY; LONDON, W. C.

SOUTH AFRICAN OFFICE: MANSION HOUSE CHAMBERS, ALDERLEY STREET, CAPE TOWN.

NEW ZEALAND OFFICE: 63 DIXON STREET, WELLINGTON.

AUSTRALIAN OFFICE: 83 PITT STREET, SYDNEY.

SUBSCRIPTION RATES

Single Copies.....25 cents

Yearly Subscription, including postage:

To United States, Mexico, Cuba, Porto Rico, Hawaii, and Philippines.....\$2.00

To Canada.....1.50

To all other countries.....3.00

The date after your name on the wrapper is that of the month to which your subscription has been paid. If you do not want to continue your subscription after that time, kindly notify us.

Notice to discontinue or change of address should be sent to the Scranton office.

When notifying us of a change of address always give your FORMER as well as your present address.

TABLE OF CONTENTS

EDITORIAL—	
Editorial Notes—Justice to Inspector Haley—The Oklahoma Mine Law	693
EFFECT OF THE MEXICAN REVOLUTION ON MINING.....	695
PERSONALS.....	696

COAL MINING AND PREPARATION

THE STORY OF A MAY DAY.....	697
THREE RAILS FOR MOTOR GATHERING, by J. C. Duncan.....	701
LEGALITY OF CHANGED MINE OPENINGS.....	701
APPARATUS FOR DETECTING MARSH GAS, by G. A. Burrell.....	702

CORRESPONDENCE—

Position of Stoppings to Withstand Explosions—Working Vertical Bituminous Coal Seam—McCurtain Mine Disaster—Influence of Roof on Position of Timber.....	703
--	-----

GOLDEN ROD COAL MINE RULING.....	704
THE SMITH GAS PUMP, by W. Bert Lloyd.....	705
ANTISEPTIC TREATMENT OF MINE TIMBERS.....	706
HISTORY OF COAL DUST EXPLOSIONS, by E. B. Wilson.....	707
NEW PRESIDENT OF THE LEHIGH VALLEY COAL AND NAVIGATION CO. A DESERVED PROMOTION.....	714
HYDRAULIC FILLING IN EUROPEAN MINES, by L. Bucherer.....	715
BOOK REVIEW.....	718

OBITUARY—

Theodore Albert—James M. Turner.....	719
--------------------------------------	-----

IMPROVED COKE OVEN PRACTICE.....	720
HISTORY OF THE SAFETY LAMP.....	721
USING ELECTRIC POWER ON A STEAM HOIST.....	721

ANSWERS TO EXAMINATION QUESTIONS—

Utah Mine Foremen, October, 1911.....	722
TRADE NOTICES.....	724

ORE MINING AND METALLURGY

GOLD DREDGING UP TO DATE, by Arthur Lakes.....	725
ORE MINING NOTES.....	729
ATLANTIC CITY MINING DISTRICT, WYO., by O. R. Taggart.....	730
CANVAS TABLE.....	731
BRAZILIAN CARBONS, by J. K. Smit.....	732
TOP SLICING AT THE CASPIAN MINE, by Wm. A. McEachern.....	733
REMOVING MOISTURE FROM IRON ORE, by John S. Nichol.....	734
MECHANICAL SAMPLING OF ORES, by O. Binder.....	735
GASOLINE INDUSTRIAL LOCOMOTIVES, by Frank C. Perkins.....	737
COST PER FOOT OF DRIVING DRIFTS, GOLDFIELD, NEV.....	738
THE "NEW METALLURGY," by H. Stadler.....	739
CATALOGS RECEIVED.....	742
TIMBERING A SMALL SHAFT, by John T. Fuller.....	743
PREVENTION OF MINERS' PHthisis.....	745
THE OCCURRENCE OF TIN, by J. E. Carne.....	746
TAILING DISPOSAL DEVICE AT COLBURN MILL, by W. G. Zulch.....	748
MAGNETIC SEPARATORS.....	749
VARIATIONS OF THE COMPASS NEEDLE.....	750

SQUIBS—

Indicated Horsepower, 700—Water Gauge, 703—Reply Postage on Foreign Mail, 731—Conditions in the Kantanga, 731—Bully for the Old Five-Gallon Oil Can, 734—Lubricant for Air Compressors, 737—Use of Caudles in the Transvaal, 742—Bismuth Alloy, 745—Holding Leases Without Operating.....	748
---	-----

WHEN a mine manager arrives at the point where he can't learn anything from the experience of his colleagues or subordinates, it is time to retire him on a pension based on the value of his services up to the time when his brain refused to act.

來 來

IN mining and milling operations, it pays to substitute machinery for manual labor, if the interest on the cost of the machine plus 10 per cent. a year for depreciation and repairs, plus cost of power to operate it is less than the wages paid for the manual labor which it replaces. This, naturally, is based on the inference that the machine does as good or better work.

來 來

EVERY once in a while the non-technical press announces the discovery of a method by means of which more gold can be extracted from ore than is shown by a fire assay. The fellow who promotes the financing of such a method is a twin brother to the one who sells stock in a mine containing thousands of tons of high-grade ore "in sight."

來 來

THIS time the dispute as to wages, etc., between the anthracite miners and operators was settled in a comparatively short time, because there were no "Butinskis," either clerical or political. In this connection we do not refer to the gentlemen who composed the Commission appointed by the President, which settled the former dispute, but to the busybodies who made such a commission necessary. The prelate, jurist, business men, and others who composed the Commission were men of a different type. They performed their duties speedily and well.

來 來

IT IS related that when Colonel Goethals, to whose masterful management the rapid work on the Panama Canal is due, was an instructor in engineering at West Point, he asked his class the following question: "The post flagstaff, 60 feet long, has fallen; if you had a sergeant and ten privates how would you proceed to put it in place?"

Each member of the class immediately got busy figuring on the use of a derrick, tackle blocks, etc., and finally turned in their answers. The Colonel at once said: "You are all wrong. The proper way would be to say, 'Sergeant, put that flagstaff in place.'"

The lesson that Colonel Goethals impressed on his students is one that is applicable to many operations

around a mine. It frequently occurs that a superintendent does the work his foreman should do, and thus makes two mistakes: (1) He wastes time that should be applied to more important matters, which are therefore neglected, and (2) he is usurping the functions of a subordinate, injuring the foreman's prestige with his men, and inculcating in the foreman's mind an idea that he must not presume to do things that are essentially his duty.

來 來

A LOCAL rescue corps, properly trained and equipped, can do better and faster work in cases of emergency than a corps brought from a distance, no matter how well trained. Therefore, the function of the Bureau of Mines Rescue Corps should be limited to instructing and training local corps, except in cases where no local corps is established. Under such circumstances, the Bureau of Mines Corps should operate under the direction of the local mine inspector or a competent official familiar with the mine workings and the conditions existing therein.

來 來

FOR the benefit of anthracite coal purchasers, we wish to remark that a 10 per cent. advance in the wages of anthracite mine workers does not mean 10 per cent. on the wages of the men who mine the coal only. It means a similar advance to the laborers inside and outside the mine, the drivers, loaders, repairmen, pumpmen, hoisting engineers, breaker engineers, breaker hands, and others who are employed in and about the collieries. Out of about 170,000 mine workers in the anthracite regions only 26 per cent. are classed as miners. The other 74 per cent. are men engaged in other necessary work in and about the mines. If a 10 per cent. advance applied to the miners only, a small advance on the price at which coal is sold would even things up for the operators, but when the 10 per cent. advance applies to all the mine workers, as it does, a larger advance is necessary.

來 來

THREE things are necessary in a successful ore mining project: (1) A good property, (2) honest financing, (3) competent management. The absence of either one of the features mentioned means loss to investors. Before investing in a mining security, the purchaser should assure himself that the engineer who reports on the property is both competent and honest, and that his report is not a mass of generalities; that the men promoting the mine are not only honest, but that they have been careful in assuring themselves that the engineer's report on the property is trustworthy before they lend their names and reputations to the project. It sometimes occurs that men of high reputation are innocently drawn into permitting the use of their names in floating securities of doubtful value. If the property is all right, and the scheme is honestly

financed, the probabilities are that the management will be technically competent. If it isn't, it will be speedily changed and made competent. With the three features mentioned, success is absolutely sure. With the first two satisfactory, and the third wanting, loss will probably occur at first, but success will be attained eventually. Investment in mining securities is not a gamble, if the investor uses the same caution that is used in other enterprises.

來 來

Justice to Inspector Haley

MR. FRANK HALEY, Assistant Inspector of Mines of District No. 3, Oklahoma, has written us, taking exceptions to several statements in our article on the McCurtain, Okla., mine disaster. His first, and, naturally, most important objection, is to the statement that he was quite late in arriving at the mine after the explosion. He states that he arrived there on the first train.

In a personal letter, Professor Steel has confirmed Mr. Haley's statement that he arrived at the mine as soon as he could. He wishes to apologize to Mr. Haley for the wrong impression conveyed to the editor by his article. He could not be more explicit as to the time of Mr. Haley's arrival, without unduly criticizing others, and he merely wished to emphasize the great confusion in the camp after the explosion. He blames Mr. Haley only for not taking general charge of the rescue work shortly after his arrival.

In another editorial in which we criticize the Oklahoma Mine Law, it will be seen that the territory under the supervision of each district inspector is entirely too large. Notwithstanding this, Mr. Haley inspected the mine oftener than was required by law. This fact, as well as the hard work done by Chief Inspector Boyle and Mr. Haley, after their arrival, was shown in Professor Steel's article.

In his letter to us, Mr. Haley also takes exception to the statement "doubtless the inspector knew of drunkenness in the camp." This he states, was unfair to him, as he never saw any of the mine officials, from fire bosses up, take a drink of intoxicating liquor. There is no reason to doubt Mr. Haley's direct statement on this point, as with a district as large as his, and with his headquarters nearly 100 miles by rail from McCurtain, he could not be expected to know of such things.

來 來

The Oklahoma Mine Law

THE mine disaster at McCurtain, Okla., on March 20, has naturally called the attention of the mining world to the coal mine law of that state.

Through the courtesy of Chief Mine Inspector Boyle, a pamphlet copy of the original act approved April 6, 1908, and supplements thereto approved May 16, 1908, and February 18, 1909, has been sent MINES AND MINERALS.

The law is not a voluminous one, and is a mixture of good and vicious restrictions and requirements. The good in the law is what the miners, mine officials, and mine owners have a right to expect from the state in which they work or operate mines.

State legislatures seldom contain many men familiar enough with mining conditions to enable the passage of entirely rational laws, and as governors are seldom chosen from among the mining fraternity, it cannot be expected that a near approach to perfection can be attained in the initial law. Neither can improvements be effected without the criticism of those who possess the necessary mining knowledge.

Therefore, for lack of space and the sake of brevity, we will confine our review of the law to some of the faulty portions.

In the first place, the division of a state with a total area of nearly 70,000 square miles, or about one and one half times the size of Pennsylvania, into but three inspection districts, even if the number of mines is limited, puts entirely too much territory under the jurisdiction of each of the three district inspectors to enable them to properly perform their duties. An inspector's efficiency, provided he has the necessary ability, is in almost direct proportion to his familiarity with local conditions in his district. How can one man ever become familiar with the local conditions, with districts as large as those of Oklahoma?

The provision of the law regarding the selection of the chief inspector and his three assistants is radically wrong. MINES AND MINERALS has consistently opposed the idea of selecting mine inspectors by popular vote for over thirty years. Some of our reasons for so doing were published in our June issue.

Next, the salaries paid the chief inspector and his assistants are entirely too low to insure the securing and retention of capable men. The salary paid by Oklahoma to its chief inspector, \$3,000 a year, is no more than should be paid a competent district inspector. The chief inspector's salary should be not less than \$4,000, and preferably \$5,000, a year. The paltry \$1,500 a year paid the district inspectors is less than many mine owners pay their inside foremen, and a state inspector is supposed to be technically the equal or superior of any mine foreman in his district.

A ridiculous feature of the election of district mine inspectors is that the nominee receiving the majority of votes cast *in the state* is the one elected for the district for the inspectorship of which he is a candidate. The election of mine inspectors who have won the right to stand as candidates by proving their fitness in competitive examinations and who are chosen by the voters of the district in which they live is bad enough, but Oklahoma's method is infinitely worse. Not only is the Oklahoma Mine Law a vicious one in the respect of choosing mine inspectors, but it is ridiculously inconsistent.

The Act of May 16, 1908, makes it unlawful for any

man to act as a mine manager, superintendent, pit boss, hoisting engineer, or fire boss, unless he possesses a certificate of competency issued by a State Mining Board. Thus, men who are supposed to have proved their competency, and who in many cases receive larger salaries than the district inspectors, are required to submit to the ruling of state officials who have not proved their technical competency, and who, if they had, would not be content to work for the remuneration paid by the state.

The law is one that professes to provide for the protection of the lives of the mine employes, yet it puts a premium on the practice of "shooting from the solid" by prohibiting the screening of coal before weighing. Every practical miner knows that blasting from the solid produces a maximum amount of slack and fine coal, and a minimum amount of lump. He also knows that an incompetent miner will always blast from the solid, as will those who are reckless enough to indulge in the practice rather than to undercut or shear a loose end. If the law, instead of prohibiting screening entirely, would limit the size of opening between screen bars to something reasonable, before weighing, there would be no temptation to shoot from the solid.

Space is too limited to take up every bad feature of the law, but enough has been shown to convince intelligent mine workers and mine officials that the Oklahoma Mine Law is badly in need of revision by a competent commission of mine officials, intelligent miners, and mining engineers.

來 來

Effect of the Mexican Revolution on Mining

The following extract from a personal letter from an American mining engineer in Zacatecas, Mexico, is interesting as showing the effect of the present rebellion on the mining and metallurgical industry:

The most pronounced effect of the present revolution has been the ruination of business throughout the republic. Mexico City, the commercial center of Mexico, reminds a traveler of some town that has been besieged and cut off from the outside world for months. Only a few of the largest mining companies are still running, and they have been threatened with dynamite shortage. All small mines have closed, development work has been stopped, practically, and several large transactions contemplated by New York capitalists, have, to my knowledge, been practically killed for the present and near future, at least.

The opinion of the majority forecasts the triumph of the government. The newspaper reports carried into the United States are absolutely unreliable. The government has been winning victory after victory in the north. The rebels are harrassed by a shortage in water and food, and are deserting Orozco by the hundreds. They are also running short of ammunition and funds. The triumph of the government looks almost certain at the present writing. The above reports and opinion were just brought here by two prominent mining engineers who had been in and around Torreon.

In event of the final rout of Orozco, it is believed that he will take to the mountains and wage a guerilla warfare for some months. This will cause the government to keep a large force of regular troops in the field. Zapata, in the south, is still giving the authorities a little trouble, but once Orozco is routed, Zapata will quickly be put *hors de combat*.

No matter how soon the revolution may end, it will be 6 months to 1 year before business will begin to assume even an aspect of normality. Plants such as the Guggenheim's, at Velardena, will not start until they are assured of the stability of government.

The war has practically bankrupted the government. Orders have been given the post offices to issue only a very limited amount of money orders each day. In many parts of Mexico the crops have failed to come up to expectations, and a famine is not an impossibility. In fact, it has been years since the Mexican treasury has been in such a precarious shape.

Opinions vary as to whether Madero will step out or not, even in case of victory. It seems almost certain that the cabinet will change in any event. One of the most optimistic signs is the disappearance of the intervention scare, it being replaced by a more conservative expression on the part of the Mexican press.

采 采

Personals

L. K. Armstrong is president of the Spokane Mining Men's Club.

J. E. Spurr is vice-president and geologist for the Tonopah Mining Co.

Eli T. Conner has been on a professional trip to Newfoundland.

J. C. Collbran is acting manager of the Seoul Mining Co., Pyongyang, Korea.

Charles Zabriskie is superintendent of the Iron Blossom mine, Tintic district, Utah.

James Fitzgerald is superintendent for the Tintic Mining and Development Co., Eureka, Utah.

Robert C. Davis, of Butte, Mont., has taken charge of the Snowshoe mine for the Montana Smelting Co.

James N. Caldwell, of Denver, Colo., is manager of the Gilpin-Eureka Mining Co., operating in Gilpin County.

A. A. Rolleston, of Cripple Creek, has been spending several months inspecting mining properties in Rhodesia.

Will Ball, of Chicago, was in Scranton on business connected with automatic weighing machine which he represents.

C. A. Dawley, M. E., whose specialty is compressed air applied to mining, has opened offices at 90 West Street, New York City.

Julius A. Lewishon has been made president of the Kerr Lake Mining Co., and W. G. Nickerson, of Boston, has been elected a director.

A. L. Burris has been reelected president of the El Paso Gold Mining Co., thereby winning in a stubborn contest for the control of this great mine.

James B. McDonald has resigned his position as manager of the New Monarch Mining Co., Leadville, Colo., and is succeeded by Orvil R. Whitaker.

Frederick Engle has accepted the position of assayer with the Colorado Mining Co., operating a gold mine and cyanide mills at Aroroy, Island of Masbate, P. I.

Willis Lawrence, formerly manager of the Florence-Goldfield property, at Goldfield, Nev., is in Manchuria, managing a large mining concession held by Americans.

W. R. Crane, Dean of the School of Mines of the Pennsylvania State College, left for Alaska about June 15, where he will study the mineral resources of that country.

I. J. Heffner, of Centralia, Pa., division mining engineer for the Lehigh Valley Coal Co., has been promoted to the position of division superintendent, succeeding J. H. Humphrey, with offices at Centralia, Pa.

Dr. Regis Clément has been engaged to deliver two courses of lectures next year at the Colorado School of Mines, of which he was formerly president. His subjects will be stoichiometry and theoretical chemistry.

C. F. Tollman, Jr., professor of geology in the University of Arizona, Tucson, is back of some proposed legislation looking to the geological surveying of the mining districts of his state.

Captain Joseph Hodgson, general manager of the Breitung mining interests, has been appointed general superintendent of the Copper Queen mines, with headquarters at Bisbee, Ariz.

Ward Blackburn is in the general sales department of the Ingersoll-Rand Co.'s New York office, devoting his attention principally to the Leyner drill, now controlled by that company.

A. W. Calloway, general superintendent of the Rochester and Pittsburg Coal and Iron Co., with headquarters at Punxsutawney, has been appointed general manager of the company, with offices at Indiana, Pa.

Blair Sackett has resigned his position with the Cerro de Pasco Co., in Peru, to take a responsible place on the staff of the Granby Consolidated Mining, Smelting and Power Co., operating at Goose Bay, B. C.

E. P. Mathewson, manager of the great smelting works of the Anaconda company, was presented a gold medal by the Institute of Mining and Metallurgy in recognition of his distinguished services in the metallurgy of copper.

H. C. Parmelee, western editor of *Metallurgical and Chemical Engineering*, and secretary of the Colorado Scientific Society, addressed the Colorado Electric Club, Denver, May 2, on "Metallurgy; Its Past, Present, and Future."

J. H. Humphrey, E. M., division superintendent of the Lehigh Valley Coal Co., with headquarters at Centralia, Pa., has been promoted to the position of chief mining engineer for the same company, with headquarters at the general offices in Wilkes-Barre, Pa. He succeeds Mr. A. B. Jessup, who resigned to become general manager of the Markle collieries at Jeddo, Pa.

Henry W. Crees, honorary secretary of the International Interchange of Students, personally conducted for a short time six English students who are touring. Later he is to conduct 30 Canadian students through the British Isles.

Dr. Henry M. Payne, consulting mining engineer, of 42 Broadway, New York, has become associated as mining and metallurgical specialist, with Stephen T. Williams and staff, at 346 Broadway, New York. He left New York, with other engineers, the latter part of May for the Yukon and Klondike gold fields, to return late in the summer.

Neil Robinson, of Charleston, W. Va., secretary of the West Virginia Operators' Association, was burned on the leg by the blowing out of a spark plug of an electric mine locomotive, on which he was sitting. His injury prevented his attendance at the recent meeting of the West Virginia Mining Institute, much of the success of which was due to his efforts.

Edgar A. Collins, formerly superintendent of the Montana-Tonopah mine, Tonopah, Nev., and also formerly superintendent of the Combination mine at Goldfield, Nev., recently resigned the management of a large South African mine to accept another position with the Montana-Tonopah Co. He will be superintendent of the Commonwealth mine, in Arizona.

The mining men of Spokane, Wash., recently organized a section of the American Mining Congress, with the following officers: Chairman, G. B. Dennis; vice-chairmen, W. J. Harris, J. H. Tilsley, and J. W. Turner; secretary-treasurer, Sidney Norman; supervisors, J. A. Finch, Patrick Clark, E. P. Spalding, Fred Burbridge, Conrad Wolffe, J. C. Haas, E. A. McDonald, W. H. Linney, G. E. Kingsley, G. A. Collins, and M. Baumgartner.

Graham B. Dennis, chairman of the Spokane section of the American Mining Congress, has appointed W. J. Nicholls, J. H. Tilsley, and W. J. Harris as a committee to raise \$10,000 for the convention of the American Mining Congress in Spokane next November. The Spokane Chamber of Commerce guaranteed \$5,000 to the congress, and it is the intention of the local section to use any funds in excess of that amount in providing excursions to the Coeur d'Alenes, and to Republic, Wash.

COAL MINING AND PREPARATION

The Story of a May Day

Interesting Things Pertaining to Mining Seen in a Short Trip in the Wyoming Valley, Pennsylvania

It was one of those days in May that eclipse the proverbial day in June, when bugs and snakes thrust their unwelcomed attention on the lovers of nature. After a week of cloudiness followed by a week of rain, there came an hysterical day in which smiles of sunshine mingled with preceded and subsequented tears of rain; and then followed one of those glorious May days which happen only in the eastern United States, a day when trees and sod vied with each other to cover their nakedness. The young

Woodward No. 3 shaft is a concrete-lined shaft 800 feet deep and surmounted by a steel head-frame. The dimensions of this shaft are shown in plan, Fig. 2, as well as the dimensions of the concrete air-courses leading to the fan. All the surface arrangements at this place are not finished at this writing, although well along toward completion; for which reason only those parts in working order will be mentioned.

From this shaft only sufficient coal will be hoisted to the surface to supply the boilers, but a very large quantity will be lowered in cars from the Hillman and other beds to the Baltimore bed, and then run through a rock tunnel 3,300 feet long to the Red Ash bed, from which it will be hoisted to the Woodward breaker.

In this tunnel, which is 7 ft. x 14 ft. in cross-section, will be

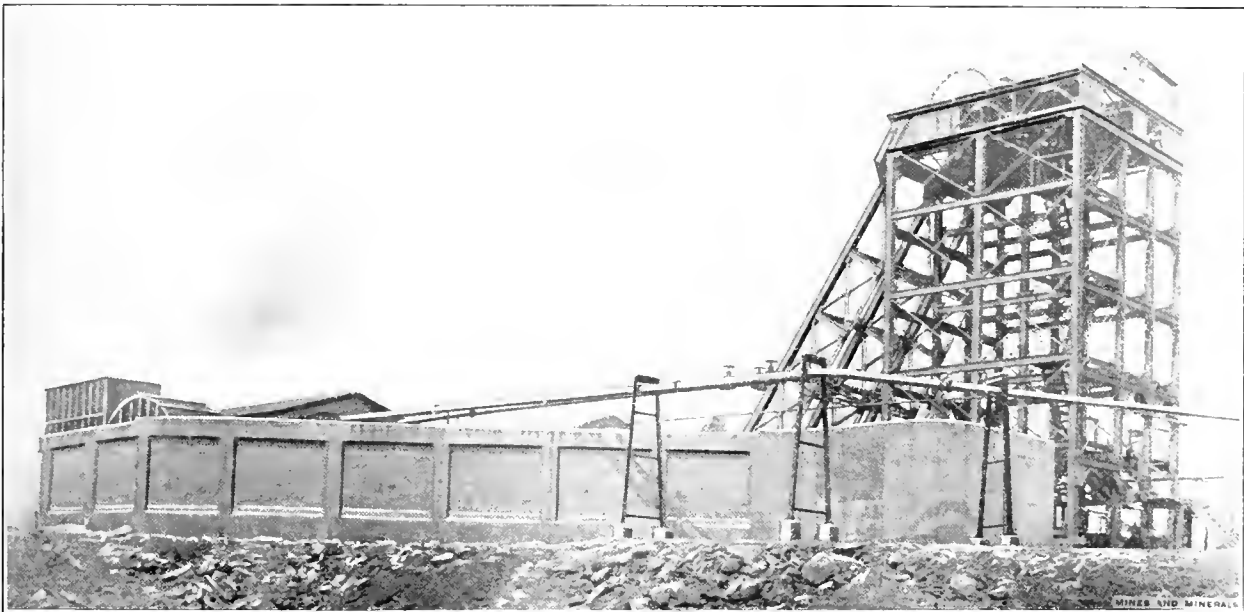

FIG. 1. FAN, AIRWAY, AND HEAD-FRAME, WOODWARD NO. 3 SHAFT

and tender grass shivering in the breeze was dotted, here with segregations of "forget-me-nots," and there with disseminated "Johnny-jump-ups"; while the distant trees were as resplendent in blossoms as specimen quartz in the Porcupine with gold, or whitewash on a West Virginia miner. Having gotten this far the writer was interrupted by the telephone. It was an invitation from Mr. H. G. Davis, Division Superintendent of the Delaware, Lackawanna and Western Coal Co., to go the rounds with him to inspect the construction under way in his district. Acting on the Spanish proverb, "Better be wise than rich," we caught the Wyoming Valley flyer for Wilkes-Barre. The interesting sights en route re mining, were the cave-in where the Wyoming Valley railroad once had a road bed; a stream of water spouting from the top of a high cone-shaped culm pile on a culm pile fire; about 200 mine mules frisking in a lot and awaiting the time when the district delegates of the miners should ratify the subcommittee's agreement with the operators. The mules seemed entirely satisfied with the suspension even if the miners' wives were not. One of those automobiles was awaiting at Wilkes-Barre to convey the party of three through the fields of onions to Woodward No. 3 shaft, where considerable surface work is under way, as shown in Fig. 1.

found supports of creosoted timbers, concrete arches, brick arches, and steel mine timbers. This combination will furnish a test of the materials best adapted to the purpose and conditions for which they are intended, and it would appear that the minimum strength of all four would exceed the present generation's ultimate activities. The buildings so far completed at No. 3 shaft comprise the engine and fan house, the boiler house being in course of construction. An excellent brick engine house covers a Vulcan 24" x 60" duplex first-motion engine that is coupled to a pair of cone drums 10-foot diameter at the small ends and 12-foot diameter at the large ends. The engines are fitted with steam reverse, steam brake and clutch thrower, also a positive worm-driven indicator. In case anything happened to the hoisting engineer an automatic device prevents overwinding, by shutting off the steam, applying the brakes, and even reversing the engine.

There are two 20' x 7' Jeffrey steel fans at the Woodward No. 3 shaft, one being held in reserve because there is so much gas in these mines the fans cannot be stopped, even for a short time, without endangering the lives of the miners.

A surface view of the cement airway leading from the shafts to the fans is shown in Fig. 1 and a plan of the fan connections

is shown in Fig. 2. Both fans are some distance away from the shaft; one is driven by a 28" x 24" Ridgway engine, and is capable of exhausting 420,000 cubic feet of air per minute. On that part of the airway above the shaft an explosion door *b* is placed, and in the wall a brick blow-out *a* to relieve the pre-cursive wave in case of a serious explosion. Double doors are arranged to shunt the air from one fan to the other.

The Woodward colliery was next visited, and here the new work consisted in the installation of a new fan, an apparatus to prevent overwinding, and an exhaust-steam turbine plant.

The D. L. & W. Co. ordered six Jeffrey fans and Ridgway engines to drive them, which is rather a fancy order.

The exhaust-steam turbine, 1,000 kilowatts, is from the Westinghouse Company, and with the exception of the cooling tower is a duplicate of the one at the Penn-Mary colliery described in December, 1911, MINES AND MINERALS. It is the writer's inten-

tions dumped into a hopper about midway between the two shafts. The hopper feeds a traveling belt which moves up the incline shown, to the top of the breaker, and delivers the coal to screens that size it preliminary to its preparation for market.

The Loomis shafts, as shown in plan, Fig. 3, are 50 ft. 4 in. x 14 ft. over all, and 48 ft. 4 in. x 12 ft., inside measurements. They are twin shafts, 200 feet apart, each divided into four compartments having the same area; however, the pump compartment occupies space in one shaft while a ladderway occupies the corresponding space in the other shaft. With the exception of the partition between the air-shaft and the pumpway the entire shaft is timbered and lagged. The wall and end plates are 10" x 12" creosoted timbers, the studdles and buntons 10" x 10" creosoted timbers, the guides 6 in. x 8 in., and the lagging 2-inch plank. The timber sets are placed 4 feet apart in the shaft, every fifth ring being made a bearer by projecting the ends of the plates so they

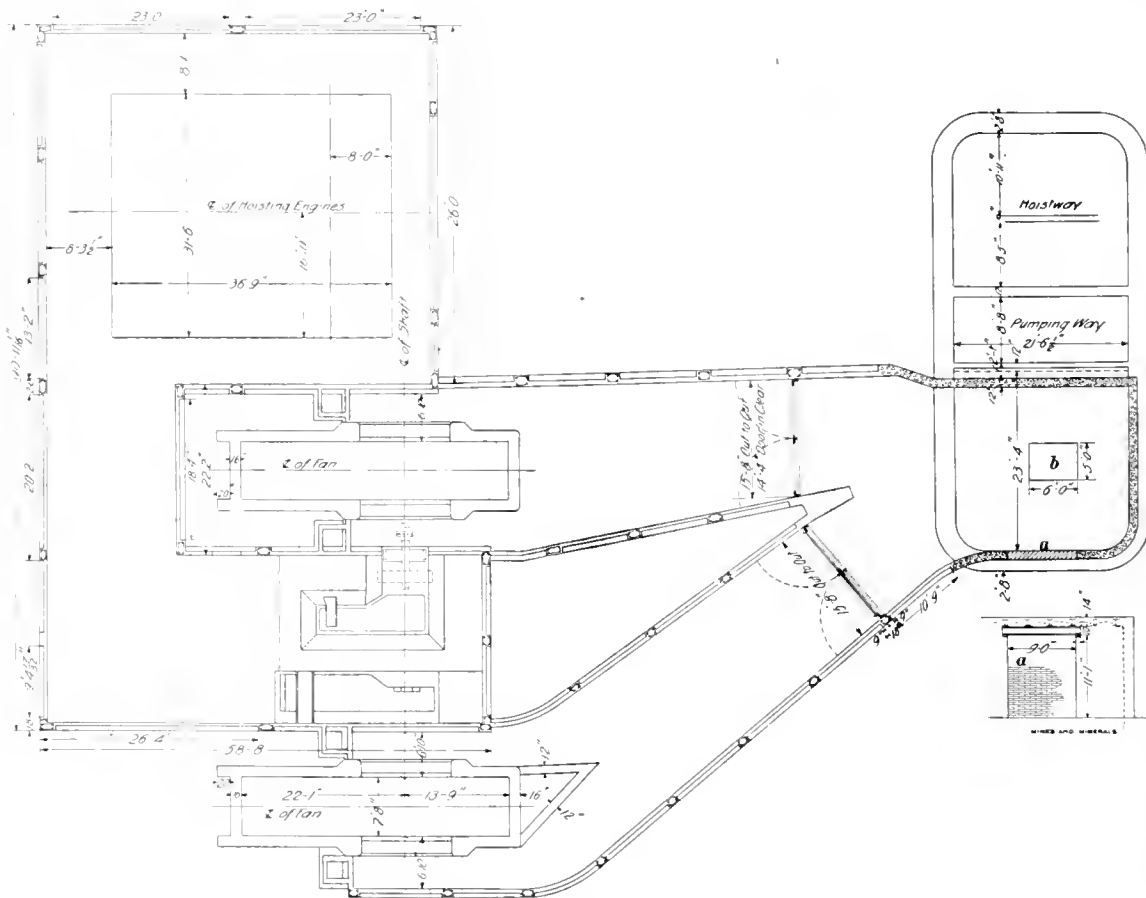

FIG. 2. PLAN OF SHAFT AND SURFACE WORKS, WOODWARD NO. 3 SHAFT

tion to give a detailed description of this plant after it has been put in running order; though at the present time it is not quite ready for operation.

From the Woodward colliery the party started for the Loomis shafts north of Nanticoke, but were stopped in Wilkes-Barre just about noon by the chauffeur shutting off the power in front of a restaurant. None of the party seemed put out by the delay and continued the journey in a restful state of mind comparable with the balmy day.

Whenever new coal mines are opened in Pennsylvania, the law requires two entrances on the surface. Therefore it is the custom in the Wyoming Valley district to sink two shafts at the same time, which are called "twin shafts." The head-frames of the twin shafts at the Truesdale colliery, shown in Fig. 3, will give those unfamiliar with conditions in this field an idea of how the Loomis head-frames and the connection with the breaker will appear. The coal cars coming from both openings are

will rest in hitches cut in the rock. This arrangement divides the shaft timbering into sections which are independent of each other and will facilitate repairs whenever they are necessary. The method of holding the lagging in place is shown in section, Fig. 3. It consists of using two cleats spiked to the wall plates, one each side of the lagging top and bottom and mitered so as to shed water. As there is little side pressure to be resisted, the chief object of the lagging is to prevent small stones and water falling into the shaft. Details of the cleats, which are cut from 3" x 4" timber; joints of the buntons; and details of the framing are shown in Fig. 3. Possibly the principal feature of interest in this shaft is the concrete wall between the air and pump and ladder compartments. This was built from the bottom upwards by sending down concrete through pipes from the surface. The forms were of 2-inch plank held in place by cleats and so arranged they could be removed and reused higher up the shaft when the concrete hardened. Every fifth panel, correspond-

ing to the shaft rings, is brick, and while air-tight is not-so substantial as the concrete.

These brick partitions, called "blow-outs," are intended as precautionary measures in case there should be a serious gas explosion in the mine which might wreck the shaft lining and fan connection, provided the precursive wave was allowed to rush up the shaft. The writer has never heard of a gas explosion in the anthracite fields doing much damage to a shaft; and it is not probable that a general explosion will occur in the deep mines of the Wyoming Valley, because of the large airways and excellent ventilation, nevertheless it shows the public that the coal corporations are not taking anything for granted, and are anticipating even remote possibilities of disaster.

To build the concrete wall, two 5-inch-diameter pipes were put down from the surface, one at each end of the wall. These pipes terminate in the upper part of the form to be filled with concrete and in a hopper at the surface. The concrete is mixed by hand in two piles one opposite each hopper and is shoveled into the respective hoppers. While one pile is being mixed, the other pile, having been mixed, is sent down the pipe, thus alternately the material spreads from each end of the form making a

and 3, of the Lackawanna basin. This slope is 777 feet long and was driven at an angle of 15 degrees. It is called Loomis No. 1 slope and will be used as an intake and haulway; however, a second slope will connect by a tunnel with one of the shaft airways, and be the return airway for this mine. The portal and the first 125 feet of the slope are concrete.

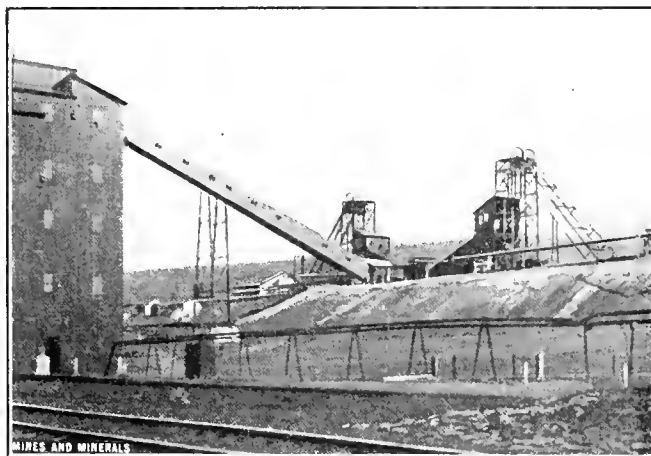

FIG. 4. TWIN SHAFTS, TRUESDALE COLLIERY

It is customary for large concerns to sink shafts on contract, and it is policy to do so, unless the company men in charge of the work are dependable and experienced. The D. L. & W. is fortunate in having such men, as they save considerable money in sinking these shafts; on the reverse side of this sinking proposition, another company that attempted to perform similar work

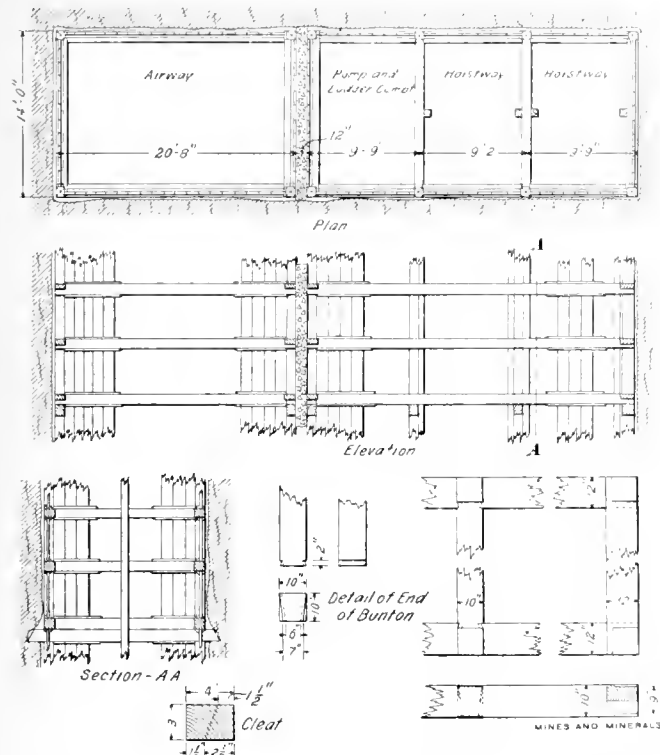

FIG. 3. PLAN AND DETAILS OF TIMBERING, LOOMIS SHAFT

compact wall 12 inches thick. There were reasons why it was not advisable to employ mechanical concrete mixers in this work. However, the hand work was quickly and economically accomplished, it being possible to fill ten panels or 40 feet of concrete wall daily. The airways in both shafts are joined at the surface by a reinforced concrete conduit 14 ft. x 18 ft. inside; and these join to a common airway that leads to a 20-foot-diameter fan driven by a Ridgway engine. In Fig. 5 a plan and section of one of these airways is shown. The two airways join on the surface midway between the two shafts, and not far from their junction the fan is placed. It will be noted that the explosion door is placed directly above the shaft, as in the Woodward No. 3 shaft; and this, with the shaft blow-outs mentioned, should ease up the blast to practically nothing when it reached the fan.

Nearby the Loomis shafts a slope has been driven to reach the three Snake Island beds, each of which is about 3½ feet thick, and are said to correspond to the Olyphant coal beds 1, 2,

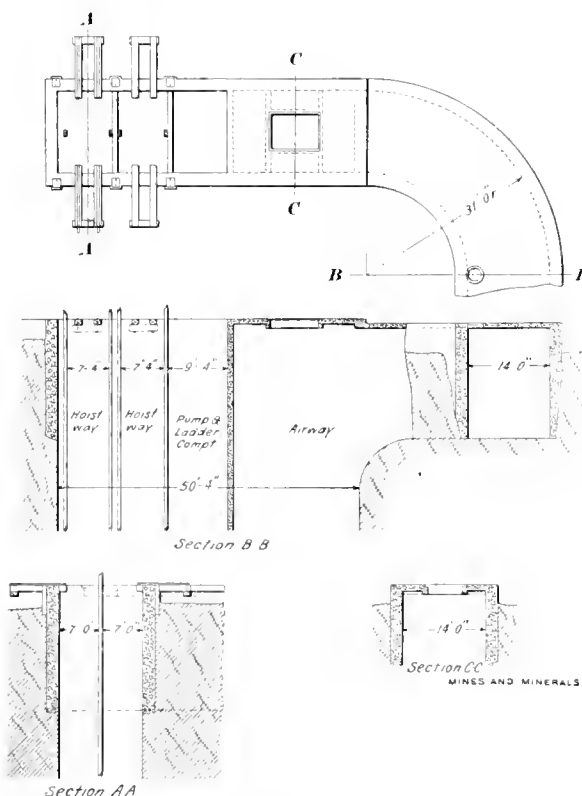

FIG. 5. PLAN AND SECTION OF AIRWAY, LOOMIS SHAFT

is perfectly satisfied to let it to contractors in the future, asserting that the worry due to incompetency was more than the money saving involved. The Loomis shafts were put down in 18 months; and while it will probably take another 6 months before coal will be hoisted through them, nevertheless the progress has been remarkable when the magnitude of the work is considered.

To the northwest of the Loomis shafts is the Nanticoke power house shown in Fig. 6. In this is a central station power plant for furnishing a number of collieries with electricity. It is located on the east bank of the Susquehanna River so that by driving a tunnel it is in a position to obtain a supply of water for condensing purposes and boiler feed supply. Unfortunately the river water contains a good bit of sewerage from the cities on its banks and on its tributaries, besides is made acid by possibly a hundred collieries discharging mine and washery water into it; in fact it is the "black Alfarata of the blue Juniata." Under such conditions it becomes necessary to filter and then treat the filtrate with chemicals before it is used in the boilers. To accomplish this two 750,000-gallon concrete reservoirs have been constructed with filter beds.

The Wyoming Valley is notorious for the uncertainty of its ground. As an illustration there is a ledge of rock on which this power house was built. When the excavation for an addition was made the ledge was found to be replaced by loose ground which made the work difficult.

was not much new work being projected. On the way over, however, a strip of ground possibly about one-quarter mile long by 100 feet wide was observed to have sunken from 2 to 3 feet. The following information was obtained from Mr. Davis concerning this cave, which differs so materially from the holes observed here and there through the anthracite fields.

In mining the bed which affected the surface, the pillars were pulled as soon as the rooms were worked out, with the result that from 96 to 98 per cent. of the coal was obtained. This does not seem to conform with the remarkable statements sent out from time to time concerning the waste of anthracite being 60 per cent. of the coal in the ground.

To show what a great day this was, one of the party lost his hat, and before the machine could be stopped on the hill the place was passed about 150 yards. The road was narrow but the machine certainly could have backed up, and when about to suggest this Mr. Davis asked, Is it coming? and some one saying yes, the order was given to tackle it when it came past. The owner made the first tackle and that was all that was necessary. The

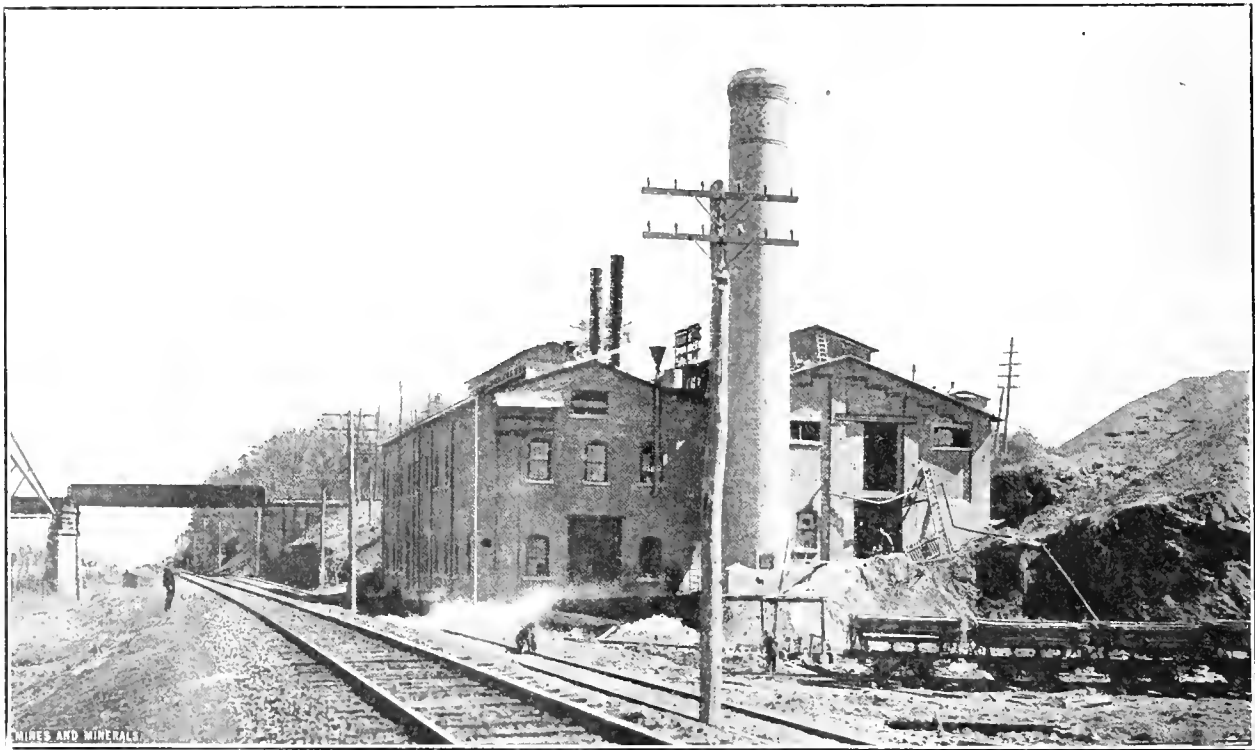

FIG. 6. NANTICOKE POWER HOUSE.

Owing to the new work contemplated and under way the Lackawanna Company is increasing the size of the Nanticoke power plant and has ordered from the Westinghouse Company a 12-panel switchboard, which is interesting because the oil circuit-breakers will be arranged for wall mounting on pipe-frame supports; that is, no cell structure will be required as in former Westinghouse oil circuit-breakers. This modification will make a compact and neat installation. The board is to control two 4,000-kilowatt normal rating, 6,600-kilowatt maximum rating, 4,400-volt, three-phase, 60-cycle turbogenerators; eight 2,000-kilowatt, three-phase, 4,400-volt feeders, and provision is made for two future turbogenerators of the same rating as those mentioned above. The present generating system consists of five 500-kilowatt turbogenerators.

Owing to the miners' suspension the contractor on the power-house work was compelled to use briquets in his crane and locomotive boilers. They seemed to answer his purpose even if the smoke did have a bilious look. From the power house the automobile carried the party to the Truesdale breaker where there

writer is indebted to Mr. C. E. Tobey and Mr. H. C. Davis for the material in this story.

來 來

The Horsepower of an Engine

The indicated horsepower of an engine is found from the following formula:

$$\frac{P-L-A-N}{33,000}$$

Where P = mean effective pressure;
 L = length of stroke in feet;
 A = area of piston in square inches;
 N = number of revolutions multiplied by 2.

Example: If a 16" × 18" engine is running 150 revolutions per minute and the mean effective pressure is found by the indicator to be 40 pounds, what is the horsepower? Substituting in above formula:

$$\frac{40 \text{ lbs.} \times 1\frac{1}{2} \times 201 \times 300}{33,000} = 109.6 \text{ horsepower}$$

Three Rails for Motor Gathering

Method of Avoiding Danger From Latches and Frogs at Mouths of Rooms

By J. C. Duncan*

The object of the system of tracks here described is for the purpose of allowing an electric motor to enter rooms in coal mines, pull out the loaded cars, and place empty cars in the room necks.

One of the drawbacks to motor gathering has been the necessity of having latches and small frogs at the mouth of every room on the cross-entry. These latches and frogs required that the motor run very slowly, otherwise it was apt to get off the track, and if it did not, some of the cars were liable to do so. To overcome this difficulty three rails are laid in the intake airways of a pair of cross-entries with switches as shown in the sketch. The switches entering the room may have a spring latch or the old style latch on the outer rail, or the room switches may be without latches entirely. From the general direction of the switches entering the rooms it is much better for the gathering motor to work from the inside out toward the main entry, and for this purpose crossing *a* is made at a proper distance from the main entry. The entry trip is hauled into the crossing *a* on the two rails next to the ribs *b*. The motor then backs into entry *c* or *d* according to which one of the two has the loaded cars to be gathered on any trip. In this way the empty cars are pushed ahead of the motor. Upon passing the first room where there is a loaded car the motor is cut loose from the empties, enters the room and pulls the loaded car out. While this is being done the trip rider cuts loose an empty car and pushes it past the room switch, so as to be out of the way of the motor leaving the room. So soon as the motor is on the entry again it is hitched to the car that has been placed by the trip rider and this it pushes ahead of the loaded car to the room neck. After this has been done the empty cars are pushed ahead and the loaded car is pulled behind the motor to the next room. At this point the loaded car is detached before the room switch is reached and the operation of pulling out the loaded car and putting in the empty car is repeated. This operation is continued until all the loaded cars are gathered and the empties placed, after which the trip is taken to the parting on the main entry haulway, the motor being ahead of the trip. The parting on the main entry haulway should be arranged to accom-

modate cars from four or more pairs of cross-entries, as it is from this parting the trips are hauled to the shaft.

One of the advantages of the 3-rail system is that the room switches can be laid without interfering with traffic. A straight solid track is provided for speeding with an empty trip of cars on the cross-entry haulway, a factor which greatly lessens the danger which arises from cars jumping the track, such as injury to trip riders and motor drivers, wrecks and damaged cars, traffic delay, and derangement of the entire haulage system with all that implies underground and on the surface. It will be noticed that the track next to the rib *b* has no switches, thus all the advantages of a main entry track are found on the cross-entry. The middle rail might be used for centering the entries when driving; however, it is probable that two or three plumb-lines furnished by the surveyor will prove more accurate and satisfactory.

來 來

Legality of Changed Mine Openings

George Harrison, Chief Inspector of Mines, being unable to decide as to the legality of a change made in the Imperial mines, located at Derwent, Guernsey County, Ohio, referred the matter to State Attorney-General Timothy S. Hogan.

It seems that this mine was originally 114 feet deep from the surface to the coal, the main hoisting shaft being about the same depth. Section 929 of the Ohio code makes the provision that in a perpendicular shaft of 100 feet or over in depth the operator is required to lower or hoist out of a mine the employes. When the vertical shaft is less than 100 feet in depth and the stairway approved by the District Inspector of Mines is not provided, the operator is required to lower or hoist persons as above described; but when such stairway is provided and approved the hoisting of persons shall not be required.

As shown in Fig. 1 the change made has reduced the perpendicular distance to less than 100 feet and increased the distance of travel at the top of the shaft 30 feet with a down grade of 13 1/3 per cent., and also increased the distance of travel at the bottom 60 feet with a down grade of 15 per cent. in order to reach the level of the coal.

In his reply Attorney-General Hogan says: "From your statement of facts I gather that the shaft which was sunk by the O'Gara Coal Co. and which was used by the men as ingress and egress was originally 114 feet deep, that certain changes were made at the entrance to the shaft, making a 13 1/3 per cent. slope; and at the bottom of the shaft by shooting down at the top and filling the bottom with rock and constructing a new traveling

*Benton, Ill.

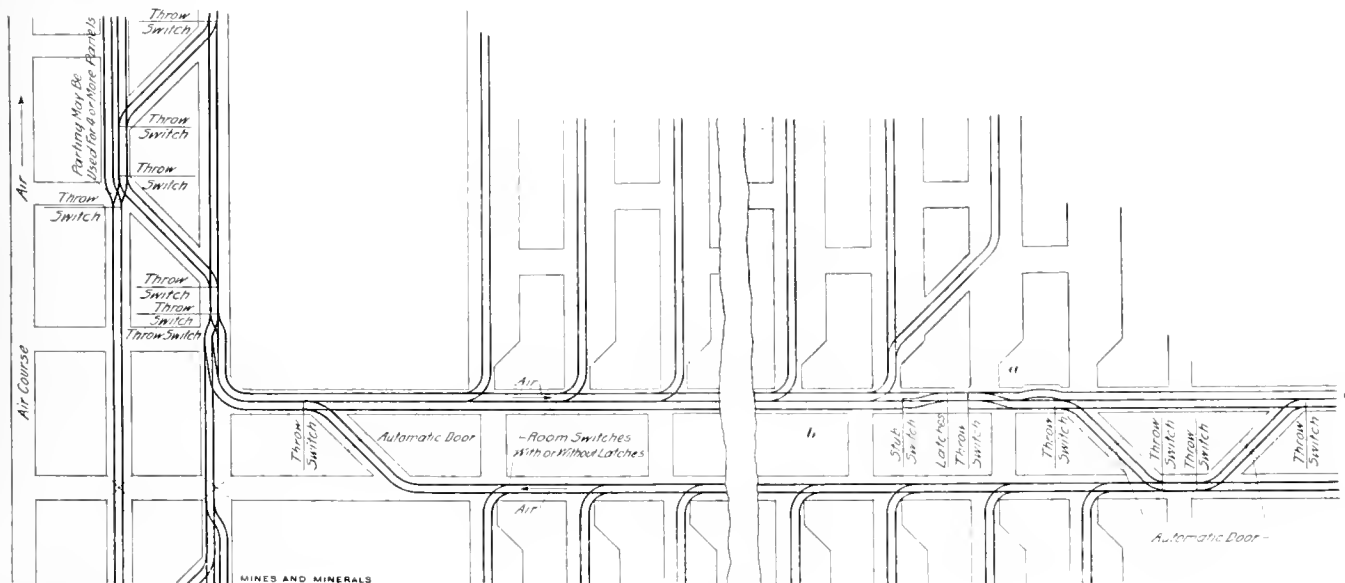

SYSTEM OF THREE RAILS FOR MOTOR GATHERING

way, making a slope of 15 per cent.; that by reason of these changes the 'vertical distance' from the 'new bottom' to the foot of the slope at the top of the shaft is now 99 feet; and you inquire as to the duty of the O'Gara Coal Co. in regard to the lowering and hoisting of their men.

"It is contended on the part of the O'Gara Coal Co. that Section 929, of the General Code, does not apply to the situation pre-

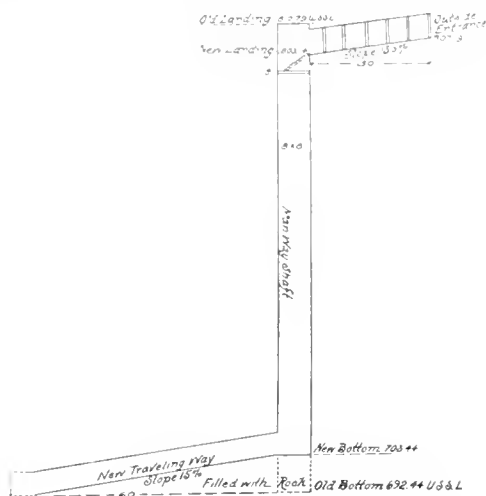

FIG. 1. SKETCH OF MANWAY SHAFT AT IMPERIAL MINE

sented at their mine for the reason that the vertical part of the travel into and from their mine is less than 100 feet, to be exact 99 feet and 6 inches. It is claimed that the remaining 14 feet of the vertical distance is eliminated by slopes of such reasonable grade that the burden of descending and ascending into and from this mine is no greater than if the shaft was originally less than 100 feet deep.

"Prior to the enactment of Section 929, General Code, there was no law compelling mine owners to lower and hoist men into and from shafts. There are shafts in Ohio ranging from 60 to 400 feet, and the distance in the deeper shafts is so great as to be a hardship on the men if they are compelled to walk into these mines and up therefrom by means of steps, hence the change in the statutes. The mining commission, composed of the Chief Inspector of Mines and a representative of employers and employees, agreed that in all mines where the only means of ingress and egress was by vertical shafts, if the depth is 100 feet, or over, the mine owner should be compelled to designate one or more persons whose duty it should be to attend to the lowering and hoisting of the men into and out of such mines, as provided by Section 929, General Code.

"I cannot agree with the contention of the O'Gara Coal Co. that Section 929, of the General Code, does not apply to the situation presented at the O'Gara mine. The 'vertical distance' from the surface to the coal is still beyond 100 feet. If the men travel through this vertical shaft 100 feet, if going down, they are still within 8 feet of the bottom, and if going up they are 6 feet from the top.

"I am, therefore, of the opinion that Section 929, General Code, does apply, and that the means employed by this company to eliminate the excess in the 'vertical distance' beyond 100 feet by constructing slopes is an evasion of the statute; that the reasonableness of the grade adds no argument in its favor. If I should hold that companies could construct slopes of 13½ per cent. and 15 per cent. at the top and bottom of vertical shafts as was done in the case before me, other companies in order to avoid lowering and hoisting men would be authorized to construct slopes of 40- and 50-per-cent. grade and compel men to travel slopes of longer distance than those constructed by the O'Gara Coal Co. and thereby defeat the object of Section 929, General Code.

"I, therefore, hold, as a matter of law, that the O'Gara Coal Co. is compelled to designate one or more persons whose duty it shall be to attend to the lowering and hoisting of persons into and out of the mine, as provided by said Section 929, General Code.

"In my judgment, all the facts contained in your communication, together with the blueprint, disclose that beyond question the shaft, within contemplation of law, is a vertical shaft. The change made at the top no more takes away from this shaft the true characteristics of a vertical shaft on the whole than the facts bring the case out of the 100-foot requirement of Section 929."

TIMOTHY S. HOGAN,

Attorney-General.

來 來

Apparatus for Detecting Marsh Gas

By G. A. Burrell*

The following is an abstract from a paper read at the Coal Mining Institute of America by G. A. Burrell, descriptive of a simple apparatus for testing marsh gas or methane CH_4 .

The illustration shows a gas analysis apparatus which has been assembled especially for the use of mine superintendents, foremen, and inspectors. With it methane can be determined with an accuracy of .1 per cent. in less than 10 minutes. It consists of a vessel *A* for measuring the gas, and a vessel *B* for burning the methane from a measured volume of mine air. The sample pipette is shown at *C*. The mine air is drawn into the measuring vessel from the pipette, measured, and passed into the burning vessel.

The platinum wire in vessel *A* is electrically heated to a white heat and allowed to remain at this heat for 3 minutes. The current is then broken and the pipette cooled. The air in vessel *A* is then drawn back into the measuring vessel *B* and the contraction in volume due to the burning of the methane is determined by again measuring the sample. This contraction in volume, when divided by 2 and calculated to a percentage basis, gives the amount of methane present in the sample. The measuring vessel, or burette, has a total capacity of 50 cubic centimeters and is divided into the bulb at the top, having a capacity of 45 cubic centimeters, and the stem, which has a capacity of 5 cubic centimeters. The stem is graduated in .05 cubic centimeter or twentieths. Water is used both in the measuring and burning

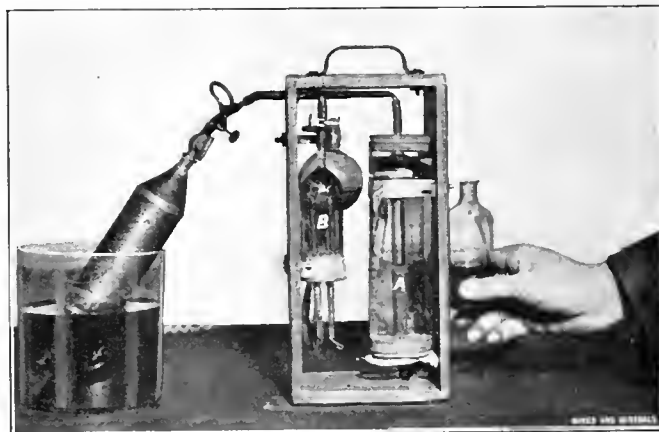

GAS ANALYSIS APPARATUS

vessels. The apparatus works on no new principle, but follows the method adopted by Coquillon, Winkler, and others who burn the methane out of a measured volume of mine air.

The Bureau of Mines has assembled other types of gas analysis apparatus more accurate than the one described, but which are not simple of operation, and which are meant for the use of chemists.

*Chemist, United States Bureau of Mines.

來
Correspondence
來

Position of Stoppings to Withstand Explosions

Editor Mines and Minerals:

SIR:—I noticed the article in the April issue and Mr. Conway's reply in June, relative to the position of air stoppings on entries to withstand explosions. It seems to the writer that they should be on the return side of the breakthrough and nearly flush with the entry for the reasons that fresh air will dilute any bad air that might accumulate, and the position will prevent any bad air from the return accumulating. Again, dust would not settle in the breakthroughs to so great an extent, since the intake does not ordinarily carry so much dust as the return.

I think, with Mr. Conway, that if the breakthroughs were sealed up solid, the chances of their being blown out would be greatly lessened; however, breakthroughs are extremely important when an accident takes place, and to seal all of them would, in my estimation, be bad practice.

E. BENJAMIN

Scranton, Pa.

Editor Mines and Minerals:

SIR:—I note with interest the reply of Mr. Conway to my inquiry as to the proper location of stoppings to best withstand the force of an explosion which usually travels along the intake, and which intake is also usually the haulage road. The reasons assigned for the choice in location were as follows: If placed flush with the rib of the haulage road (intake) the heading would be similar to a rifle barrel and the speed of the explosive wave would be so great that it would pass by the stopping without knocking it out, whereas, if placed on the return side or anywhere inside of the rib of the haulage entry, the wave would have a chance to expand into the cross-cut, possibly to gather more dust, with a resultant secondary explosion and consequent complete destruction of the brattice. The advocate of stoppings on the return side of the pillar claimed it was advisable to get "everything" as far away from an explosive wave as possible, while the middle-of-the-pillar man was not very clear in his ideas, but seemed to think that if the explosion traveled both the parallel headings there would be as much room for expansion on one side of the brattice as the other, the pressures would naturally balance and no harm would result.

My own choice is for the first-named location, and for the reasons stated because I have in several instances, while cleaning up after an explosion, noted that brattices which were flush with the intake escaped with no or but trifling injury, while those placed in the cross-cut were destroyed. The reason may not be the true one, but it seems to work out in practice. Of course, all brattices built as stated did not escape destruction, but the percentage of damaged ones was much greater when built inside the cross-cut.

Columbus, Ohio

Working Vertical Bituminous Coal Seam

Editor Mines and Minerals:

SIR:—In reply to Mining Engineer, of Farmington, Ill., concerning method of working steeply pitching seam, it would seem advisable to follow method used in the anthracite mines of Pennsylvania, where the same conditions as to thickness and pitch of seam are met with.

Drive a slope along the dip of the seam, or a shaft that will intersect the seam, and turn gangways about 300 feet apart on the dip. From these gangways turn breasts directly up the dip on centers which will be governed by the character of the roof and the strength of the coal. The size of chain and stump pillars will likewise be governed by the strength of the coal. Details

as to method of operation can be found in description of any of the mining operations of the Pennsylvania anthracite mines.

MINING ENGINEER

McCurtain Mine Disaster

The following letter, which explains itself, was received by Professor Steel:

SIR:—I note in your article on the McCurtain mine disaster, there was some criticism offered for my not having a pulmotor or an oxygen reviving apparatus. I had one pulmotor and one knapsack oxygen reviving apparatus with me when my party went in the mine the first time. I can't see how this statement got out. Mr. Henry Fields and myself also found the two men in the slope that were said to have died while they were being worked on. I made a thorough examination of these men several hours before the other party worked on them, and in my estimation these men had been dead then for several hours. I would appreciate it very much if you will have this mistake corrected

WM. T. BURGESS,

Foreman Mine Safety Station, Bureau of Mines,
McAlester, Okla.

May 9, 1912

Influence of Roof on Position of Timbers

Editor Mines and Minerals:

SIR:—Wish you would publish the following question relative to enclosed point:

Section A is the last of a series of pillar work carried on for many years past, the coal having been withdrawn completely

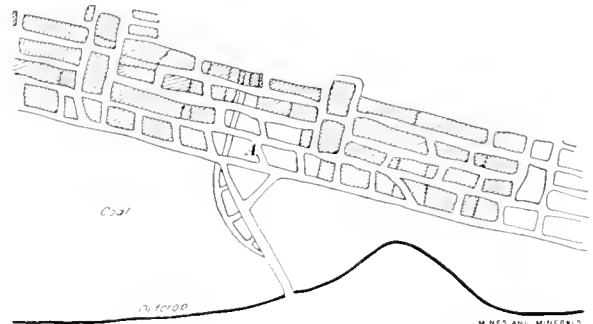

from the far side of the mountain—without any loss whatsoever. The timbers in the standing area today all have a marked leaning toward the outcrop on the side of the driftmouth; i. e., the tops of the timbers incline toward the outcrop. No evidence of a squeeze is present—that is, there is no weight on the pillars. How could the leaning of these timbers be due to anything else?

MINE FOREMAN

來 來

The pressure or water gauge required to force air through a mine may be obtained by multiplying the total rubbing surface by the square of velocity of air and a coefficient of friction (.000000005), and dividing the product by 5.2 times the sectional area.

A mine has 208,000 square feet rubbing surface, a sectional area of 100 square feet and 100,000 cubic feet of air is required per minute, what is the water gauge?

$$\text{Solution: } \frac{208,000 \times (1,000)^2 \times .000000005}{100 \times 5.2} = 2 \text{ inches}$$

NOTE.—The coefficient of friction may vary in ratio of from 1 to 10 on different mines, and it is a very uncertain quantity.

Every precaution should be taken to keep large airways, and it is best to assume that no mine should be permitted to get into a condition requiring over 3 inches water gauge pressure to ventilate it on every-day duty.

Golden Rod Coal Mine Ruling

One Entry Divided by a Concrete Wall Held Not Legally to Constitute Two Traveling Ways

February 16, 1912. Hon. George Harrison, Chief Inspector of Mines, Ohio, wrote to Timothy S. Hogan, Attorney-General, Ohio, as follows:

"We have in Ohio an operation to wit, the Golden Rod mine, situated in Noble County, owned by the Guernsey Coal and Mining Co., of Newark, Ohio, where the management of the mine, who, after driving the main entries several hundred feet, double entry, came in contact with faulty coal of irregular thickness and of somewhat inferior quality, and without consulting this department, or notifying us, as required by Section 939, ceased to drive one of these entries, widening out the other one and continuing it as a single entry, using ordinary canvas cloth, for dividing the space lengthwise, and as a means of conducting the air; contrary to the provisions of Section 926 which states that breakthroughs between entries shall not exceed 60 feet apart, they drove this single entry in this way over 600 feet without the writer ever having been notified of the fact.

"They commenced building a concrete partition, dividing the entry into two spaces lengthwise and designating it 'two separate and distinct traveling ways, as required by Section 931.' They have started a new development at the inner end of the single entry, with the artificial partition, and from that point have driven double entries, and working quite a number of miners and employes.

"We desire that you advise this department at your earliest opportunity:

"First. Does this artificial partition in the single entry constitute two separate and distinct traveling ways, as provided for in Section 931, with breakthroughs in the natural strata between two places, as required by Section 926?

"Second. If this proceeding is contrary to the provisions of Section 931, are they justified in making this new development beyond the single entry without first providing a second and lawful traveling way?

"Enclosed find a copy of the investigation of this matter by three of our District Inspectors, who reported on this matter September 26, 1911, but thinking this company would provide means of escapement we have not yet taken any definite action."

"George Harrison, Chief Inspector of Mines, Columbus, Ohio.

"Pursuant to your suggestion, we have today, in company with Inspector Ellwood, of the Fifth District, examined the concrete walls used to divide the single entry in the Golden Rod mine, in Noble County, into two compartments, and in connection therewith wish to report as follows:

"Beginning at a point approximately 200 feet east of the bottom of the shaft the entry was driven for a distance of approximately 1,014 feet in a general easterly direction. Six hundred and forty-three feet of this entry was driven single and since being driven it has been separated lengthwise into two compartments by a concrete wall. This wall is reported by the mine management to be 21 inches thick at the bottom and from 9 to 10 inches thick at the top, its height varying with the height of the entry. The south compartment was found to be as small as 4 feet 10 inches wide and 5 feet high in one place, while on the north or haulage road side, one measurement shows a height of entry 4 feet 10 inches and width 7 feet. This entry was driven in violation of Section 926 of the General Code in that breakthroughs were not made at the prescribed distances.

"This wall is a poor and unsatisfactory substitute for natural strata and is the only means, which, under present conditions, provides two traveling ways from the interior of the mine to the surface. In all common such traveling ways are inadequate as a safe and ready means of escape in a probable emergency. The

wall could be readily destroyed, resulting in the entombment of those employed in the mine.

"In view of this condition and in order that the safety of those employed in the mine may be properly safeguarded, we would suggest that an order be given the Guernsey Coal and Mining Co., to provide an additional traveling way from the interior of the mine to the surface.

Respectfully yours,

ROBERT WHEATLEY, Inspector Twelfth District.

L. D. DEVORE, Inspector Tenth District.

JOHN L. McDONALD, Inspector Third District."

Attorney-General Hogan answered as follows:

"You inquire first:

"Does this artificial partition in the single entry constitute two separate and distinct traveling ways, as provided for in Section 931, with breakthroughs in the natural strata between two places, as required by Section 926?"

"Section 931 of the General Code provides in part as follows:

"The owner, lessee or agent of a mine shall provide and maintain, in safe condition for the the purpose provided, two separate and distinct traveling ways from the interior workings of the mine, each of which shall be available to not less than one opening to the surface. One of such traveling ways may be designated by such owner, lessee or agent as the principal traveling way. One of such traveling ways may be designated as the escapement way. The provisions of this section shall not prohibit such owner, lessee, or agent from designating more than one principal traveling way, or more than one escapement way, so long as the provisions thereof are complied with."

"Section 926 of the General Code provides in part as follows:

" * * * From a point where the seam is reached in the opening of a mine, to a point not exceeding a distance of 400 feet therefrom, *breakthroughs* shall be made between main entries, where there are no rooms worked, not more than 100 feet apart, provided such entries are not advanced beyond the point where the breakthrough will be made until the breakthrough is complete. Breakthroughs between entries, except as hereinbefore provided, shall be made not exceeding 60 feet apart. * * * "

"It appears from the statement of facts contained in your letter and from the report made by your inspectors that the coal company mentioned drove its main entries several hundred feet, double-entry system, came in contact with faulty coal of irregular thickness and inferior quality, and without consulting your department, ceased to drive one of these entries, widening out the other one to about 12 feet, and drove it as a single entry through this fault, using ordinary canvas cloth for dividing the space lengthwise as a means of conducting the air during the driving of the entry, and after it was driven 600 feet, built a concrete partition 21 inches thick at the bottom and 9 or 10 inches thick at the top, the height varying with the height of the entry. The coal company claims that they have, by erecting this concrete wall in a single entry, complied with Section 931 of the General Code as to providing two separate and distinct traveling ways for their employes. It further appears from your statement of facts that after they had driven through this fault and constructed the cement partition that they are continuing the double-entry system.

"Answering your first inquiry, it is my opinion, in contemplation of law, that there is from the point where the double entry ceases and where they begin at the end of the 600 feet, which is divided into two ways by an artificial wall, but only one traveling way. The law contemplates two traveling ways separated by natural pillars and walls: Section 926, quoted above, provides that breakthroughs shall be made every 60 feet in the entry; not artificial openings in an artificial wall, but breakthroughs made through coal, slate, etc.

"It was the intention of the legislature in the enactment of the mining code to safeguard the lives of the men employed in the mines: that adequate means of escape be provided in cases of

emergency. All laws passed to protect the lives of men employed in mines should be strictly construed and rigidly enforced. The dangers incident to mining coal are great enough without adding thereto by lax enforcement of the mining laws on the part of those charged with the enforcement thereof, and by a too liberal

distinct traveling ways from the interior workings of the mine, each of which shall be available to not less than one opening to the surface. If the only means of ingress and egress to that part of the mine beyond this single entry divided by the cement wall is through the single entry, then I hold, as a matter of law, that this company is not justified in making new developments beyond the single entry without first providing a second safe and lawful traveling way as provided by Section 931 of the General Code.

"In my judgment your department is not called upon to pass upon the sufficiency of artificial walls between entries however substantial when the statute contemplates natural support and natural division of entries."

TIMOTHY S. HOGAN,
Attorney-General.

來 來

The Smith Gas Pump

By W. Bert Lloyd

One of the most dangerous conditions in any mine, and doubly so in one generating large volumes of gas, is the possibility of the existence of a large body of standing gas in some abandoned gob where, by reason of the roof still working or because the traveling roads are blocked by falls, ordinary methods of inspection are impracticable, if not impossible.

The existence of such bodies of gas is frequently not suspected, or if suspected, their extent is greatly underestimated. Many disasters must have been caused by open lights coming in contact with such bodies of gas, either in the gob itself or in the workings where portions of them have been driven by changes in atmospheric conditions, by sudden falls of roof or by diffusion.

Any instrument which will render more certain the detection of these bodies of standing gas should be welcome to mining



FIG. 1. TESTING FOR GAS

construction of the laws on the part of those whose duty it is to construe the laws in order that they may be enforced as construed.

"The law contemplates two separate and distinct traveling ways for the ingress and egress of men in mines; it contemplates two traveling ways separated by natural walls instead of artificial walls; walls that cannot be destroyed by the explosion of powder or other accident common in mines; walls that in case of emergency requiring the escape of men, when one of the traveling ways is obstructed will leave the other free for the safe conduct of the men to the outside. From the report of your inspectors the cement wall constructed in this mine, even if it were permissible, is insufficient and unlawful. Your inspectors say:

"This wall is a poor and unsatisfactory substitute for natural strata and is the only means, which under present conditions provides two traveling ways from the interior of the mine to the surface. In our opinion, such traveling ways are inadequate as a safe and ready means of escape in a probable emergency. The wall could be readily destroyed resulting in the entombment of those employed in the mine."

"The artificial means adopted by this company in order to technically comply with Section 931, General Code, is a justification for my position that laws enacted for the protection of the lives of men employed in mines should be strictly construed and rigidly enforced. In case of a probable emergency the wall erected by this company could be readily destroyed resulting in the entombment of those employed in the mine.

"I, therefore, advise you that the artificial partition in the single entry in this mine erected to provide two separate and distinct traveling ways does not comply with Section 931 of the General Code. That in contemplation of law there is but one traveling way in that part of the entry where the artificial wall is located.

"Your second inquiry is as follows:

"If this proceeding is contrary to the provisions of Section 931, are they justified in making this new development beyond the single entry without first providing a second and lawful traveling way?"

"The answer to your first inquiry practically answers the second. Section 931 of the General Code requires two separate and

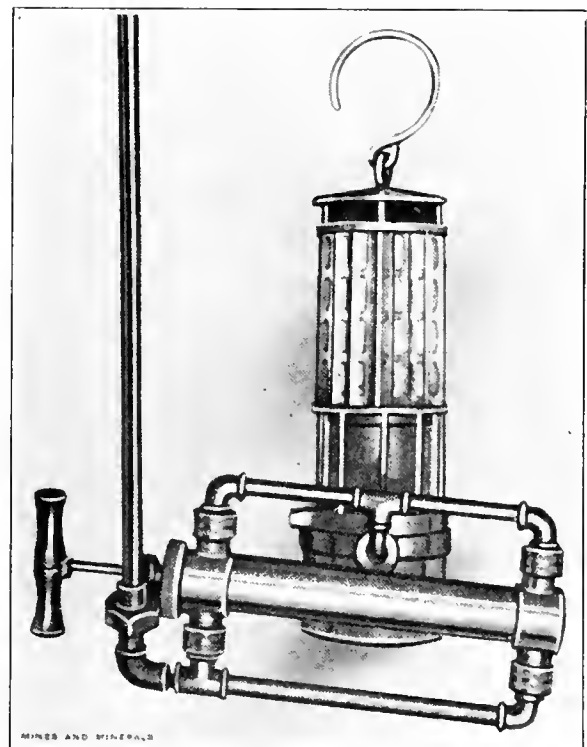

FIG. 2. GAS PUMP AND LAMP

men. For a number of years Joseph Smith, general superintendent of the Stag Cañon Fuel Co., at Dawson, N. Mex., has had in successful use a device of this type. It consists essentially of a small, double-acting pump, the discharge end of which is directly connected to the base of one of the standard forms of safety

lamp. The suction end is made up of a series of 5-foot lengths of $\frac{1}{8}$ -inch gas pipe screwed together, eight such pieces constituting the ordinary set, and the whole is easily carried by the fire boss, the weight being but small. In operation, if it is desired to try a place over a fall for the existence of gas, as many lengths of pipe as are necessary to reach to the top of the cavity are screwed together and then affixed to the suction end of the pump. A few strokes of the piston brings the air from the cave into the lamp, where the presence or absence of marsh gas is at once indicated by the appearance of the flame.

When a haulage way has been graded through a fault by cutting the floor, a more or less inaccessible gas trap is left in the roof. Such places are very often gas producing or serve as a lodgment for gases coming from other parts of the mine. Because of the difficulty of examining them and because they are right on the edge of the air-current, it is frequently assumed that no gas is or can be present until an explosion has proved the falsity of the belief. In this case and in testing gobs it is dangerous to enter; in examining high falls that could otherwise only be

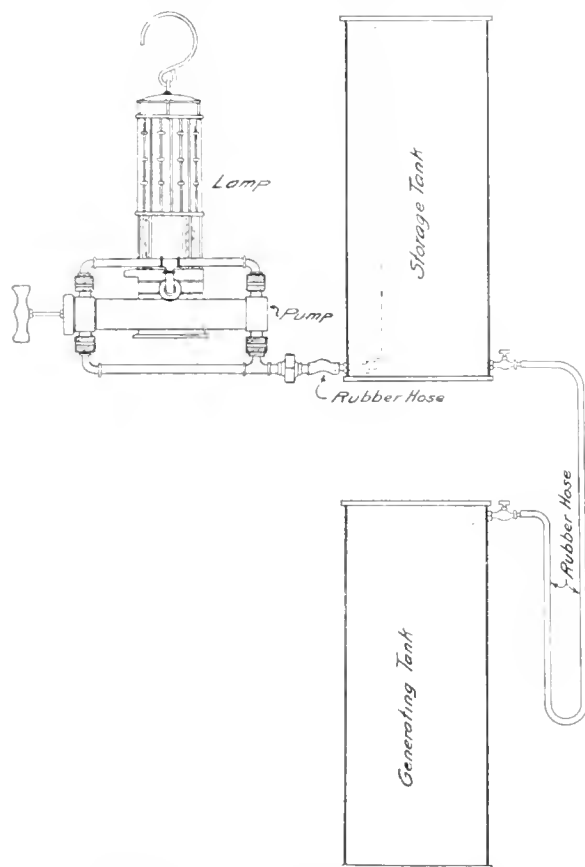

FIG. 3. GAS PUMP ARRANGED FOR EXPERIMENTS

reached by ladder and in collecting samples for analysis, the device has proved of the greatest value.

Joseph E. Sheridan, State Coal Mine Inspector for New Mexico, has given the lamp many severe tests and indorses it, particularly for determining the state of the air back of stoppings which have been built to seal off a mine fire. With one or more lengths of pipe passed through the stopping into the affected area, most accurate checks upon the accumulation of CH_4 , CO_2 , or CO may be had. Owing to the fact that the end of the tube may be placed immediately upon the roof, it is possible to detect the presence of much smaller bodies of gas than with an ordinary lamp.

Fig. 3 shows the apparatus arranged for the instruction of fire bosses, to which it is well adapted, and for which it is largely used.

Antiseptic Treatment of Mine Timbers

It has been stated that experiments on the preservation of mine timbers require from 15 to 20 years before conclusive results can be obtained. However this may be, when a plant will pay for itself in 4 years time by saving timber, it is hardly necessary to wait so long for absolute technical results.

About 4 years ago the Delaware, Lackawanna & Western Railroad installed at their Auchincloss colliery, near Nanticoke, Pa., a wood-treatment plant for mine timbers.

H. G. Davis, division superintendent of the Coal Department, D. L. & W. R. R. Co., with headquarters at Kingston, has been experimenting with various kinds of mine timber treatment in a certain place in one mine where timber sticks, such as ordinarily go into a mine, lasted about 6 months.

He first replaced the bad timbers with creosoted loblolly pine. In between the treated timber sets he placed others of the same kind of wood that had been peeled and seasoned. In the same locality loblolly pine sticks treated with lime were placed so that they would be subjected to the same general conditions. In all three instances the timbers at present are sound, but to make this doubly sure, after $3\frac{1}{2}$ years time, auger holes were bored in the seasoned wood and no signs of decay found.

While it is generally conceded that peeled and seasoned timbers will last longer in mines than unseasoned timbers, either with or without bark, nevertheless from the positions occupied by the seasoned loblolly pine relative to the creosoted sticks, a question worthy of further investigation is raised, namely, does the antiseptic creosote used in the treatment of mine timbers prevent the growth of fungi in untreated timbers in its immediate vicinity? To kill bacteria and germs of disease fumigation is a common practice, and as creosote is an antiseptic, may it not be that the odor arising from the treated timbers may kill the fungus germs in its vicinity?

The Auchincloss treatment plant is used to treat all shaft timbers, a large number of cross-ties for the various mines, and timber sets which are to replace those that have failed.

The cost of creosoting timbers will be more than in treating them with zinc chloride, owing to the higher cost of creosote. Shaft timbers and those timbers which must be placed in wet places should be creosoted; zinc chloride treatment will in all probability be preservative enough to prevent dry rot where conditions are dry and hot. The factors entering into the treatment cost will be freight, unloading at the plant; freight and reloading if the treated timbers are to be shipped; loading and unloading the cars for the treatment cylinder; treatment including the cost of creosote which at present is about $7\frac{1}{4}$ cents per gallon, or zinc chloride $4\frac{1}{2}$ cents per pound. It is usual to reckon the cost of treatment in terms of cubic feet of timber. The average cost of treating mine ties will be less than 10 cents each ordinarily, depending upon the number of cubic feet in the tie.

Mr. Davis treats loblolly pine with lime as follows: The timbers are packed in boxes with lime. After wetting the lime to slack it, the box is sealed and its contents subjected to steam over night. This treatment seems to have a beneficial effect on timbers, provided they are not stood in places too wet. If salt-treated timbers are stood in water, the wood preservative will be washed or dissolved from their pores. Consequently if timbers are to be subjected to alternate dryness and wetness they should be treated with preservatives that are insoluble in water, such as creosote.

From an economical standpoint the cost of timber treatment is not so great as pulling out old timbers, framing, and placing new sets; and if the freight, cost, and timber handling be included, a large money saving will be accomplished in a few years and much timber will be preserved that under present conditions is wasted. The Auchincloss treatment plant has paid for itself several times.

History of Coal-Dust Explosions

An Abridged Account Showing the Probable Causes and the Remedies Suggested by Their Study

By Eugene B. Wilson*

This article was suggested by reading the inaugural address of President Galloway in the Transactions of the South Wales Institute of Engineers.

Professor Galloway passed through an apprenticeship of assistant mine inspector, junior mine inspector, and inspector of mines in Great Britain. At present he is Professor of Mining at the University College of South Wales. He was the first to experiment with coal dust, and his findings in 1875 would have been given greater heed, were it not that it always requires a serious disaster before remedial steps are positively taken to prevent a recurrence; and for the sake of charity it is assumed that theoretical egotism, theoretical pottering and evasiveness, with immeasurable bone-headedness, were the obstacles in the way that prevented the acceptance of the fact that coal dust was explosive. That flour mills had exploded was known; that charcoal dust was the principal ingredient of gunpowder was known; and that neither of these depended on firedamp for ignition was also known; yet with similar phenomena to corroborate the evident fact of the explosibility of carbon dust, the gas-outburst theorists prevailed.

When the Walsend colliery exploded in 1803, J. Buddle, Colliery Viewer, said: "The workings were dry and dusty, and survivors who were the most distant from the point of explosion were burned by a shower of red-hot sparks of ignited dust driven by the force of the explosion."

In Rev. J. Hodgson's account of the Felling Colliery explosion in 1812, it is stated that "great quantities of coal dust were ejected from the shafts," and that the explorers underground "encountered smoke standing like a wall." There is no question but that firedamp will explode when furnished with a proper mixture of air; but unless there be unburned carbon, the products of the explosion will be practically colorless. As another matter of history, it was the explosion at the Felling Colliery that formed the incentive to the safety lamp of Davy.

In 1844 Messrs. Lyell and Faraday were appointed government commissioners to investigate the Haswell Colliery explosion. In writing for the *Philosophical Magazine* in 1845, these men stated that coal dust aided a gas explosion, that the dust became caked; that the caked dust under the microscope appeared to be fused and was found adhering to pillars, props, and walls; and that gas was distilled from the coal by the explosive flame. An excerpt of their article follows:†

"In considering the extent of the fire from the moment of the explosion, it is not to be supposed that firedamp is its only fuel. The coal dust swept by the rush of wind and flame from the floor, roof, and walls of the workings would instantly take fire and burn, if there was oxygen enough in the air present to support its combustion; and we found the dust adhering to the face of the pillars, props, and walls in the direction of and on the side toward the explosion, increasing gradually to a certain extent as we neared the place of ignition. This deposit was in some parts half an inch, and in others almost an inch, thick; it adhered together in a friable coked state; when examined with a glass it presented the fused round form of burnt coal dust, and when examined chemically, and compared with the coal reduced to powder, was found deprived of the greater part of the bitumen, and in some cases entirely destitute of it. There is every reason to believe that much coal gas was made from this dust in the very air itself of the mine by the flame of the firedamp which

raised and swept it along; and much of the carbon of this dust remained unburnt only for want of air."

Continuing in chronological order it will be found that in France M. du Sonich, who investigated the Firming Colliery explosion, which occurred about 1855, made two reports, dated, respectively, 1855 and 1861, in both of which he speaks of coal dust as having aggravated the effects of the inflammation of the gases.

M. Verpillieux, writing in the Bulletin de la Société de l'Industrie Minérale, 1864, compared an explosion of coal dust to the firing of a gun, and went so far as to say that "coal dust represents the powder and firedamp the priming."

In Volume 24, 1894, Transactions of the American Institute of Mining Engineers, William Glen described two explosions of grahamite dust that occurred in Ritchie County, W. Va., February 9, 1871, and February 25, 1873. Both explosions were from shots setting fire to the dust, which is a sort of asphalt. Water was used irregularly to lay the dust after the first explosion, which filled the mines full of flame and exploded with a loud report on reaching the air. These are the earliest dust explosions in mines recorded in the United States, although there were several gas explosions of local nature in the anthracite fields of Pennsylvania.

In 1872 M. Villiers attributed a very important part to coal dust in the explosion at the Jabin mine in 1871. In 1872 M. Poumairac declared "that he was convinced that in the explosion at the Cinq-Sous mine which occurred in 1867 coal dust took an important part." M. de Reydellet, referring to the same explosion, said "he had formed the opinion that the action of coal dust may sometimes be disastrous."

In 1874 M. Seibel, director of the Campagnac mines, in which an explosion took place November 2, 1874, extending a distance of from 90 to 105 feet from the face, said: "The absence of firedamp having been verified, we believe that in order to explain this accident it is necessary to admit the combustion of coal dust raised by the explosion of the shot." M. Vital made a study of this explosion and published the results of his experiments in *Annales des Mines* in 1875. His conclusions were:

"Very fine coal dust is a cause of danger in dry workings in which blasting is practiced; in well ventilated workings it may of itself alone give rise to disasters; in fiery workings it increases the chances of explosion, and when accidents of this kind occur it aggravates their consequences."

While acting in the capacity of assistant inspector of mines in 1873, 1874, and 1875, Professor Galloway made a special study of explosions in the wet mines of Scotland and the dry mines of Wales, and he observed:

1. That a firedamp explosion in a wet mine never by any chance assumed the proportions of a great explosion.
2. That all great explosions took place in dry and dusty mines.

On the 3d of July, 1875, Inspector Galloway made a mixture of air and coal dust which convinced him that the two alone were explosive and that if a small proportion of firedamp was also present the mixture could be ignited with an ordinary lamp.

In 1876, Messrs. Clark and Hall conducted a series of experiments with coal dust and shot firing, and presented a paper on their findings to the North of England Institute of Mining and Mechanical Engineers in June, 1876. In January, 1878, Professor Galloway wrote a series of articles on coal-dust explosions, and in the same year Professor Marecco and D. P. Monson read a paper before the Chesterfield and Derbyshire Institute of Mining, Mechanical, and Civil Engineers, on experiments which they had carried out on a small scale by firing a small cannon into a mixture of air and coal dust. At this time Mr. Galloway suggested two additions to the Coal Mines Regulation Act of Great Britain, which was enacted in 1872. The suggestions were productive of some good at least to the Germans and miners in South Wales. They were as follows: "No shot must on any pretense what-

*Lexington meeting of Kentucky Mining Institute, June 10, 1912.

†*Philosophical Magazine*, 1845.

ever be fired in a dry mine until the floor and sides of the working place, or gallery in which it is situated, have been drenched with water, and rendered artificially damp to a distance of at least 15 yards from the shot hole." This suggestion was adopted in 1880, but a distance of 20 yards was specified instead of 15.

The second suggestion was voluntarily adopted almost immediately in many mines of South Wales and elsewhere, and was incorporated in the laws of the Prussian Government after the Westphalia disaster mentioned. It was as follows: "In every naturally dry mine, water shall from time to time be sprinkled on the roadways and in the neighborhood of the working places in sufficient quantities to render them damp at all times, both by night and day."

In 1872 the Tradeston Flour Mill at Glasgow, Scotland, exploded; and in December, 1877, malt dust exploded in a house at Burton-on-Trent, England.

On May 2, 1878, the Washburn Flour Mills at Minneapolis were wrecked by an explosion. Professors Peck and Peckham were commissioned to investigate and ascertain if flour dust was explosive. Among other things they tested flour and coal dust, and gave it as their conclusion "that all finely divided carbonaceous material would explode."

In an issue of the Scientific American Supplement, May 25, 1878, page 1985, there was an up-to-date article on "Dust as an Explosive" which reviewed the subject as it appeared up to that time. The author was certainly alive to conditions, for he stated: "It has been well known for a long time past that it is not alone to mixtures of issuing gases with air that the explosions in collieries are to be ascribed." * * * "Dust furnishes a material which gives the fire power to spread should the mixed gases be insufficient to permit such spread."

In 1879 the Royal Commission on Accidents in Mines was appointed, and soon afterwards similar commissions were instituted by the Governments of France, Prussia, Saxony, and Austria; and these turned their attention more or less closely to coal dust. On January 13, 1879, the Dinas colliery explosion took place with the loss of 89 lives; July 15, 1880, Risca colliery explosion caused 120 deaths; September 8, 1880, 164 men lost their lives at the Seaham colliery, and on December 10, 1880, 101 men were killed in the Penygraig explosion. Professor Galloway, after careful investigation, found the following conditions at the Penygraig colliery:

1. The flame of the explosion passed through or penetrated every part of the workings, with the exception of one wet heading at the bottom of the downcast shaft.

2. There were deposits of coked dust in every working place in the mine. On the other hand, the same kind of deposits were rare in the main roadways through which the flame passed. The inference is that coal dust was largely mixed with shale dust and other impurities on the main roads, while it was comparatively pure in the rooms, and when heated became pasty and adhered to everything it was thrown against.

Mr. Galloway noted that the coked dust was for the most part traveling against the regular air-current. In some cases it appeared coked on both sides of the timbers and consequently due to a retrograde movement of the air. In 1880 Mr. Galloway made 63 experiments with coal dust as a basis, the results of which he published in the Proceedings of the Royal Society, No. 219, 1882. His explosion gallery was 126 feet long by 2 feet high inside.

In 14 experiments were made to ascertain how far the flame of the mixture of firedamp and air contained in the explosion gallery would extend along the wooden gallery in the presence of coal dust. The average length of the flames was 118 feet 6 inches.

In 10 experiments were made to ascertain how far the flame would extend in the same manner and under the same conditions as in the preceding case would extend into a cloud of coal dust. The flame propagated by the action of the air wave in

its passage through the wooden gallery. The average length of 15 flames of coal dust and pure air was 118 feet 6 inches.

3. Ten experiments were made to ascertain the effects due to the explosion of small heaps of blasting powder placed at given points in the wooden gallery, all the other conditions being exactly the same as in the last case. The average length of five flames of coal dust and pure air augmented by the explosion of small heaps of gunpowder was 145 feet.

Sir Frederic Able experimented with coal dust in 1880; his results unfortunately are not at hand for this paper. The following is copied from Wilson's "Practical and Theoretical Mine Ventilation," which was written in 1883: "Another provision which should be enforced is the use of gunpowder in all fiery bituminous mines. Shot firing has in all probability to answer for more fatal casualties than some are inclined to ascribe to it. This does not happen so much in anthracite mines, from the fact that there is scarcely any dust floating in the air when compared with bituminous mines; however, we are not sure but that it may apply in some instances even to them.

"It is certain that people are maimed and burned by blasting, at distances varying from 10 to 180 yards, when there is no fire-damp present to cause such destruction; then it is quite clear that this results either from the simple force and flame of the shot on account of the weight of the charge, or from this force and flame assisted by the rapid combustion of coal dust, as it travels on its course, or from the force and flame assisted by an instantaneous emission of gas in consequence of a partial vacuum being formed by the rushing blast."

With a view of testing the above assumptions careful experiments were made, a description of which may be found in the *Colliery Guardian*, England, page 13, Vol. XXXII, the summing up of which is as follows:

1. The flame from a blown-out shot unassisted by gas or coal dust does not travel farther than 5 or at the utmost 10 yards, entailing little or no danger.

2. If coal dust be present, even in a comparatively damp mine, the flame may not travel 50 yards. In a dry mine of a high temperature this distance would be greatly exceeded; and since miners as a rule consider themselves safe at from 15 to 20 yards from the point where the powder is used, a blown-out shot under these circumstances is a source of great danger.

3. The violence of the blast from either gunpowder or fire-damp is much increased when coal dust is present.

4. On any partial vacuum being formed in an underground coal working, firedamp will instantly issue in dangerous quantities; and there are fair grounds for assuming that a shot blowing out in the face of a narrow heading, and setting the coal dust on fire in its course, would by its exhaustive action produce such a vacuum and might cause a serious explosion in a mine practically clear of gas.

5. Although no experiments have been made directly to test the result of coal dust set on fire in air heavily loaded with fire-damp, there is every likelihood that such an occurrence would be attended with grave consequences.

6. It is desirable that any system of blasting coal which entails heavy charges of gunpowder, and an unusual liability to "shots blowing out," such as blasting without side cutting or nicking, or using improper materials for stemming, should be discontinued.

7. A large body of flame, such as results from a very heavy charge or from a blown-out shot, is required to ignite coal dust; in blasting with charges not exceeding 12 ounces, accompanied by the proper preparation of holing and side cutting, there is little liability to this taking place.

"To discard all shot firing means in many mines a considerable increased cost in the working of coal. But life is the first consideration and the safety of the miner should be the one great object of the operator. The opinion of the best mining engineers is that so long as shot firing is allowed, even under the most

favorable circumstances, so long will there be a certain amount of risk, while in many cases where the plan is adopted it often leads to most serious and fatal consequences." (Permissible explosives were not at this time in use.)

About the time Wilson's Mine Ventilation was put in circulation the Pocahontas explosion occurred, March 13, 1884, and so sure was the author that this explosion was due to dust, that he wrote a letter of condolence to W. A. Lathrop, the manager, to that effect, and received the reply that "he believed it now but did not think it possible previously."

The opinion of the commission appointed by the American Institute of Mining Engineers will be found in Vol. XIII, page 247, of the Transactions, and it fully corroborated the conclusions of the writer. The commission consisted of J. H. Bramwell, Stuart M. Buck, and Prof. Edward H. Williams, assisted by E. S. Hutchinson. The causes of this explosion, according to their conclusions, were:

- "1. The unusual dryness of the mines.
- "2. The very large quantity of dust in an extremely fine state of division.
- "3. The constant working of the mine day and night, allowing no time for clearing the air.
- "4. The use of excessive quantities of powder, largely increasing the amount of dust.
- "5. The probable existence of small quantities of firedamp slowly given off from the coal. The existence of firedamp in the Pocahontas mine is the disputed point. This committee is not satisfied on the subject. * * * The committee found no traces of firedamp. * * * On the other hand, there is testimony, although from men generally inexperienced with gas, leading to the belief that when the mine was strongly worked there was a slight but general escape of firedamp, too slight to admit of detection except in rare cases, and probably in all cases too slight to occasion danger if unmixed with dust and if diluted by proper ventilation."

In 1884 the Prussian Firedamp Commission made experiments with coal dust on a fairly large scale in an artificial gallery at Königsgarbe, Saarbrücken. The dust employed in these experiments was collected from the various collieries producing coal of different qualities, and as it was submitted to test without having been sifted to remove the coarser particles and reduce it to a uniform degree of fineness, the different kinds naturally gave different results. As a consequence, the commission reported that although some kinds of dust produced explosive phenomena and were therefore highly dangerous, others did not do so under the same conditions and might therefore be considered safe. Acting under this impression they recommended, first, a system of watering in a general way in dangerous mines; secondly, the use of short-flaming explosives in place of gunpowder in all dusty mines; and, thirdly, the thorough damping of the dust for a distance of at least 10 meters in front of every blasting shot. Soon after the completion of the experiments water mains were laid in the Saarbrücken mines, which belong to the Prussian State; and, later, some of the large Westphalian mines began to follow their example, but it was not until the disastrous explosion at Carolinenglück Colliery on February 17, 1898, in which 116 men lost their lives, that the practice became general. Investigations made after this explosion showed that a small local explosion of firedamp had, by means of the coal dust which it raised and ignited, spread throughout the greater part of the workings, with the most destructive effects ever experienced in Westphalia up to that time; and as this colliery had been considered one of the safest in the district, both in regard to its freedom from firedamp and the nature of its coal dust, it was at once perceived that the danger due to coal dust was not confined to fiery mines only, and that the inflammability of coal dust had been hitherto altogether undervalued. The authorities had by this time become convinced that there was sufficient coal dust in the workings of all dry mines to spread a local explosion over great areas, and that a thorough

damping of the dust was the only means of avoiding this danger. On December 12, 1900, a law was promulgated which abolished the distinction between fiery and non-fiery mines, and it became obligatory to dampen the dust in all dry mines without exception. Thus the coal-dust question was settled as far as Germany was concerned at that time, but in all other countries it has remained a more or less open one up to the present writing.

May 29, 1891, Henry Hall, Inspector of Mines of Great Britain, stated before the Federated Institution of Mining Engineers: "Perhaps no subject in connection with mining has attracted so much attention during the past 15 years as that of coal dust. The ignition and explosion of dust in the absence of firedamp by gunpowder shots, and by the initiatory explosion of a fixed quantity of firedamp, have again and again been effected in long galleries prepared for the purpose, and its ignition when a small and otherwise harmless amount of firedamp is present is a certainty at almost every attempt." Mr. Hall then explains some experiments in a mine shaft to remove any doubt as to the conditions in experimental chambers being the same as those present in the mine itself. He described the water pipes in use in South Wales, that were introduced at the suggestion of Professor Galloway some years previous. Attempts to saturate the air of mines with watery vapor he says were not successful. He suggested watering the cars before sending them from the mine face. He made experiments with short-flame explosives without tamping, with coal dust tamping, and with clay tamping, and compared them with gunpowder flames.

Mr. W. C. Blackett, in 1893, formulated the following theory on the action of dust and air agitation:

"First, there is an initiatory force, a gunpowder shot, a local firedamp explosion, or perhaps a heavy fall of roof. This stirs up a thick cloud of dust which can be ignited by any accompanying flame. At this stage no great violence is developed, merely an expanding inflammation, producing, however, an onrushing cloud of heat-dilated air and dust, and for some distance no force is produced sufficient to move light articles, and men in the vicinity are burned. But the cloud is now advancing against greater difficulties. In one direction it has to overcome the momentum of a swift air-current and the inertia of a large mass of air beyond; in the other direction it has the swift current of air to overtake, and then with its speed to overcome an inertia. The former is stayed and reversed and both are whirled away at an ever increasing pressure varying as the square of the velocity. If the shaft and working faces are a long way off, so much the worse will be the effects. The increasing commotion stirs up greater clouds and the increasing pressure is serving to intimately mix therewith more abundant oxygen, and pursuing this increasingly concentrated explosive mixture is the flame. Air is, however, so elastic that this accelerated movement would naturally be guided by the ordinary laws of ventilation, going the nearest way to the shaft, and to the expanded workings in the other direction. The rush of compressed air stirs up the dust and pioneers the path for the oncoming explosion. There is no turning to the right or left, doors and stoppings are blown down, beyond which the explosion may or may not pass, according to the conditions on each side of the obstacle. When the shaft is reached, the pressure is relieved and explosion ceases. In the direction of the face the explosion proceeds until the greater number of open galleries has reduced the speed of the rushing air, so that it will no longer produce a thick cloud of dust, and it dies away. It has perhaps provided its own safety valve, for the stoppings and doors into the returns have been blown down by the explosion. All the available oxygen has been consumed; indeed, there has not always been sufficient for complete combustion, and instead of carbon dioxide alone, the deadly carbon monoxide follows." Mr. Blackett further said that on the initiation "there must be enough spare power in the shot to stir up the dust and produce enough compression of air. The dust must be very fine and dry, the flame from the explosive must be of very high temperature and

of considerable volume. Possibly the shape of the gallery, the relative temperature of the air, and the height of the barometer may also be important."

Doctor Bedson's investigations in 1893 confirmed the theories advanced by Lyle and Faraday in 1884, and the others mentioned, namely, that it was only necessary for particles of coal dust to undergo the process of distillation to cause violent ignition.

Although watering mines with various appliances was instituted in South Wales and Germany in the 80's, it was not made compulsory and made little headway; further, all kinds of objections were raised to prove that it was not applicable. A. Dury Mitton remarked in 1893 that watering roads in dusty mines did not last more than a week, owing to the water not penetrating the dust where it was thick. He found that common salt could be added to advantage as it penetrated through the dust, and produced a moistening effect in traveling roads that would last six or eight weeks. T. A. Southern (1894) suggested that there should be a systematic removal of dust, not only from the floor of main roads but also from the roof and sides in addition to watering. He made the following calculations to ascertain the quantity of water which might be absorbed by the ventilating current:

"A coal mine, 1,800 feet deep, has a ventilating current of 250,000 cubic feet of air per minute. Suppose that on a damp winter's day, the air entering the downcast shaft is at a temperature of 33° F., and is saturated with vapor, and that the air when it leaves the upcast shaft is at 75° F., and is also saturated with a vapor. If the volume of air measured in the return airway at 75° F. is 250,000 cubic feet, then its volume when entering the downcast shaft would be $250,000 \times (459 + 33) \div (459 + 75) = 230,337$ cubic feet per minute.

"One cubic foot of saturated air at 33° F. contains 2.2 grains of vapor, and 1 cubic foot of saturated air at 75° F. contains 9.4 grains of vapor. The weight of vapor contained in the air when it enters the mine is $230,337 \times 2.2 \div 7,000 = 72.4$ pounds per minute. The weight of vapor contained in the air when it leaves the mine is $250,000 \times 9.4 \div 7,000 = 335.7$ pounds per minute. The weight of water absorbed by the air under these conditions would be $335.7 - 72.4 = 263.3$ pounds per minute, 26.33 gallons per minute, 1,580 gallons per hour, 37,920 gallons in 24 hours, or 169 tons in 24 hours." He thought that this result would bear out the futility of watering unless continually carried on.

At this time (1894) Mr. Ruben Allen, in charge of Tamworth colliery, was removing dust and sprinkling the traveling roads.

In 1894 A. G. Barnes, of Grassmore collieries, and William Hay, opposed watering in some collieries on account of its effect on the roof or floor, and the necessity of using timber where none was previously used.

A. H. Stokes, of the Royal Commission, stated that "watering alone was not a sufficient remedy, neither could the removal of dust be entirely depended on, as all could not be removed." The remedial measures must be looked for in the initial start of the explosion. "Stop the explosion, stop the shot firing, stop the gas explosions, and you need not take any notice of dust so far as colliery explosions go." In this connection Mr. Stokes had reference to gunpowder alone. It seems to have been generally understood that shot firing in the main haulage road or contiguous thereto in dusty mines was exceedingly dangerous, as the Act of 1887 implied.

In October, 1893, an apparatus for laying dust by means of water spray was arranged in the Hansa mines in Prussia. This mine was 2,178 feet deep and the arrangement is said to have covered the floor so well, entailing additional expenses for labor and timber.

Water spraying was introduced in Westphalia in the Hibernia mine at the Tamplaon colliery, Saarbrück, after explosions attributed to coal dust. Other collieries also adopted the system about 1890. In 1895 Robert Lamprecht wrote an article for *Oesterreichs Zeit-schrift für Berg und Huttenwesen*, on the

Prevention of Firedamp and Coal-Dust Explosions. The Rossitz collieries, although not particularly fiery, have easily inflammable coal dust. An experimental coal-dust explosion gave the following data: Flame, dark red, a large amount of coke crusts, and fumes of afterdamp, appear to be the characteristics distinguishing a coal-dust explosion. Among the plans tried to prevent explosions at Rossitz mines were: Watering by fixed and portable apparatus; steam and water; and hot water; equally unsatisfactory. However, the fine dust and other conditions such as lack of water, damage done to the mine, etc., were against watering.

In 1896 the Coal Mines Regulation Act of Great Britain prohibited the use of any explosive which the secretary of state considered dangerous, and he issued orders from time to time giving a list of tested explosives which could be used in coal mines. The test consisted in charging a 1½-inch diameter hole, 2 feet deep, bored in a steel block, with a certain weight of explosive and tamped with a known quantity of clay. If the explosive is fired 20 times into an explosive mixture of air and gas, sometimes with and sometimes without the presence of coal dust, without explosion, it is eligible to the permitted list. In 1894 an explosive testing station was installed at the Consolidation Colliery in Westphalia. The experiments at the Consolidation mine were carried on in a gallery 6 feet high, 4.4 feet wide inside, and 111.57 feet long. Experiments to determine the influence of tamping on explosives resulted in the conclusion that clay tamping added greatly to the safety of shot firing. No explosive is absolutely safe in dusty or gassy mines, but those whose action depends on a high temperature are less safe than cooler short-flame explosives.

The temperature of an explosion is not a measure of the relative safety of an explosive in the presence of firedamp and coal dust. Among other things the rapidity of an explosive affects safety, and in the Westphalian district increases inversely as the rapidity of the explosive.

In the Proceedings of the Royal Society, 1882, will be found a description of the apparatus used by Professor Galloway to prove that a mixture of air and bituminous coal dust was explosive. The cloud of coal dust thrown out of the apparatus into the open air, in some instances from 30 to 50 feet long by from 10 to 15 in diameter at its widest part, was permeated with rolling flames, identically the same in appearance, although on a smaller scale, as those clouds ejected from the larger apparatus at Altofts, England, Lievin, France, and in October, 1911, at the United States Experimental Mine, Bruceton, Pa.

The object of Professor Galloway's experiments was to elucidate the causes of great colliery explosions; and it might have been expected that his results would have settled the question of the explosibility of coal dust definitely. It would seem as if the cause having been determined, means for its prevention would have followed; but many were still inclined to attribute the cause to "outbursts of gas" which could neither be foreseen nor prevented. There are but two localities, so far as the writer knows, where large outbursts of gas occur, and those are the Lampacitos field, in Mexico, and the Crows Nest Pass field, in British Columbia, both of which are in Tertiary coal. While gas blowers are apt to occur in coal beds below water level, none have so far to the writer's knowledge been reported above water level, yet some of the most destructive explosions have occurred in mines above water level. Gas blowers are not general, and in many mines that have exploded, no gas was ever encountered before or after an explosion.

Although French engineers had taken a prominent part in assigning a certain role to coal dust 50 years ago, they rejected the fact that coal dust was explosive, and continued to oppose it, concentrating their attention on the best means of dealing with firedamp. As an indication of their attitude, M. H. Le Chatelier wrote the following in 1890 regarding the three supposed special causes of explosions, viz.:—Barometric variations, coal dust, and

outbursts of gas. "The first is purely imaginary, the second is insignificant in the absence of explosive mixtures of firedamp and air, the third alone is really serious, but happily it occurs only under very exceptional circumstances." This opposition to coal dust being explosive was shattered by the Courrieres Colliery explosion on March 10, 1906, when 1,100 lives were sacrificed. The effect was immediate; commissions and committees were appointed and experimental apparatus was erected in England, France, and in the United States, and experiments were resumed in an artificial gallery in Austria that had been discarded for years. So far nothing new of importance has been given out by the experimenters, and all the investigators have intimated that they have many more experiments to carry out. So far, the experiments of the Pittsburg investigators of the Bureau of Mines have been only of a preliminary nature and shed no particular light on the prevention of dust explosions. The last one at Bruceston experimental mine, March, 1912, was to ascertain if the Taffanel stone dust shelves were effective, but Mr. Rice states that the experiment was not conclusive.

Although there are differences in the sectional area and lengths of the experimental galleries at Altofts, England, Lievin in France, Babitz in Austria, and Pittsburg in the United States, they are comparable to the extent that a man can walk through them. The Altofts gallery, originally 600 feet, had about 60 feet at the open end destroyed by an explosion, and its length was reduced to 260 feet. The Austrian gallery is 963 feet long, 71 feet underground at its closed end and 7 feet underground at its open end. The loud detonation, the rush of flame, and the cloud of dust with flames shot out of the mouth of a tube or experimental mine, leave no doubt of the explosive properties of a mixture of coal dust and air. The Lievin gallery is 754.6 feet long.

On March 13, 1884, the Pocahontas explosion took place, in which 114 men lost their lives, and it was attributed to dust. Pete Hanraty, now mayor of McAlester, Okla., was one of the first men employed as a shot firer in Indian Territory in 1884. Up to that time he did not think anything but firedamp would cause an explosion, but he was soon convinced that firedamp was not necessary in the dry, dusty mines of Krebs and Savanna. He insisted on the company sprinkling the dust, which was done in 1885 without stopping the explosions. The same year he used exhaust steam from the pump, and laid pipes so that it would escape into the intake, with the result that there were no explosions while the steam was used. During the following years, numbers of small explosions were credited to blown-out shots without taking dust into consideration. William Clarke, of Bowen, Colo., says that in 1885 he was a driver and watered the roads in the Savanna, Indian Territory mine, using a water cart previous to the explosion, April 12, 1885.*

The dust in the Castle Gate mine was so inflammable that the United States Inspector of Coal Mines for Utah Territory, Robert Forrester, reported in 1892 that "the dust in the Castle Gate mine is very inflammable and extra precautions have to be taken. The dust is kept in a very wet condition by water pipes throughout the mine and water is taken to the working faces by a hose. Steam was used on the intakes to blow water into fine spray that air might absorb and carry it along." He reported: "On the outside the hydrometer frequently registers a difference of from 20° to 35° between wet and dry bulb thermometers, and at a point 1,500 feet from mouth of the mine the difference registered on the intake seldom exceeds 1°, while at the far end of the mine, 4,000 feet from the mouth, the air has been fully saturated for over a year."

In 1895 Joseph Watson worked the Como mine No. 5 in Park County, Colorado. The mine contained gas and a large quantity of explosive dust, consequently extraordinary precautions were necessary to prevent a repetition of the dust explosion in the fall of 1892 when 26 men lost their lives. In May, 1895, water pipes were laid throughout the mine with hose connections at

the mouth of each room. Every place in the mine was thoroughly washed down every other day.

Since the Scofield No. 4 mine explosion in Utah, May 1, 1900, when 199 coal miners lost their lives, the Utah Mine Law makes it imperative for coal companies to water their mines. Had the precautions been taken at the Scofield mines that were taken at the Castle Gate in Utah it is not probable that the accident would have happened.

In 1904 the Masurite Company commenced the manufacture of a short-flame explosive called Masurite, and in the same year the DuPont Company commenced to manufacture Nihilite, another short-flame explosive. Masurite was placed on the permissible list of the United States Bureau of Mines May 1, 1909. The DuPont Company commenced the manufacture, on a large scale, of what are now called permissible explosives in the latter part of 1907.

It will be noted that the coal miners in the Territories appreciated the dangers of coal dust much sooner than those in the East, and to them must be given the credit of first taking steps to guard against the dangers.

In the East the culminative period occurred in 1907, when a succession of explosions occurred in friable coking coal mines. Particular stress is laid on friable coking coal, because such coal, being low in bitumens compared with gas, cannel, and block coals, is more readily broken in mining, handling, and transportation, besides is more readily air slacked. When friable coal falls from the mine car, it is easily pulverized, and as impalpable powder is wafted to lodging places in the entries and rooms. Experiments made at the Bureau of Mines show that coal $\frac{1}{40}$ inch in diameter is but partly explosive, but that it is too fine for safety if of the friable coking variety.

The use of coal dirt for tamping has been a known source of danger; but the Bureau of Mines tests show that wet friable semibituminous coking coal from the Pocahontas field is more dangerous than dry coal from the same field. The finer the coal becomes the more explosive it becomes, therefore coal-dust explosions may happen in other than friable coal mines, unless proper precautions are taken, such as thorough cleaning and watering of the entries.

While this paper is in the nature of a history, its writing would be a waste of time if no conclusions were drawn from the data. The writer has seen the blue flame flash in anthracite mines, he has seen the flame roll along rooms from blown-out shots, and only lives to tell about it from the fact that it failed to reach the entries. He has seen the effects of dust explosions, and has had his circumstantial deductions verified in a number of instances; consequently the remedies he offers are not based on one, but several, explosions, and not by any means on his own observations alone. He recognizes that additional expense will be incurred by adopting the suggestions offered, but who can find credit for a fatal dust explosion? It may be that \$5,000 will be required to protect a large mine, and if there is but 10 cents profit on a ton of coal it will require 50,000 tons of coal to pay for the outlay, yet the life of one good miner is worth much more than that; besides, it is a small explosion that cannot accomplish \$5,000 damages to a mine. Those who work dusty mines are living on the second story of a powder mill; they may go up, but if they do it is their own fault.

A condition necessary to a coal-dust explosion is fine dry dust on the floor and walls of an entry. If the entry is free from fine dust there will be no more than a local explosion, whether there is a blown-out shot or a gas ignition. As it is a difficult matter to keep all dust off the entries, the next surest method of preventing an explosion is to wet the face, the floor, and walls of the excavation, for a distance of from 30 to 60 feet, previous to shot firing; for if there is no propagating flame there will be no explosion. Shot firers should be employed to see that holes are properly pointed, loaded, and tamped with clay. This, however, is but one precaution; for a blown-out shot is not always

*MINES AND MINERALS.

preventable. The permissible short-flame explosives should be used in sufficient quantity only to break down the coal; any more than this is a waste of powder, besides creating dust; and several explosions have occurred where permissible explosives were in use. All shots should have two free faces, and this can be accomplished by delay fuses when the coal is undercut or sheared.

Where end-gate cars are used and car topping is demanded, more or less coal will fall on the road beds, and the accumulation will eventually form dust, particularly if it be of a friable coking variety. This coal will air slack rapidly, be crushed by traffic, and some of it, in almost impalpable powder, will be raised by passing cars, then carried by the air until it finds lodgment on the walls of the entries, a position where the rush of air and flame from a gas explosion or a blown-out shot can propagate a dust explosion. Dry air in passing through a mine will take up the quarry water from coal, after which it becomes difficult to induce coal dust to absorb water. If entries are watered intermittently the dry air-current will absorb the moisture and the entries soon become dry again. To avoid this, water must be furnished the incoming air, on moderately cool days particularly; and, in addition, the air must be warmed before it has traveled a great distance into the mine. The quantity of water needed to humidify the ventilating current will depend on the dryness of the air entering the mine and the temperature at which it leaves. To keep a mine normal under the conditions mentioned by Mr. Southern would require 37,920 gallons or 169 tons of water in 24 hours. To furnish this quantity of water in the form of steam would not be practical, because it would require a total of $335.7 \times 1,146.6 = 384,913$ heat units, about 11 times more than are needed, and consequently would stop all work by overheating and humidifying the air.

The heat necessary to raise the mine air 42° and to absorb the moisture necessary for saturation would be:

$$250,000 \times .019 \times 42 = 19,950 \text{ B. T. U.}$$

$$335.7 \text{ lb.} \times 42 = 14,099 \text{ B. T. U.}$$

$$\text{Total heat necessary, } 34,049 \text{ B. T. U.}$$

Theoretically this can be obtained from about 30 pounds of water per minute when converted into steam. The balance, or 305.7 pounds of moisture, must be supplied by watering the entries. Next to steam, water sprays are most effective in humidifying, as they come in more intimate contact with the air than standing water on the floor, but they should not cool the air too suddenly or they will be ineffectual. Rooms are apt to become extremely dry and dusty, therefore the face and walls should be moistened previous to shot firing. With these precautions and the use of permissible explosives, it is doubtful if more than local explosions would occur in any mine. Assuming, however, that accidents will happen in the best regulated mines, even when precautions have been taken to prevent them, provisions should be made to save the valuable lives shut in the mine. As a rule few are killed by burns or violence, the great majority being poisoned by afterdamp. In recent disasters men have saved their lives, as at Briceville, Tenn., by damming off the afterdamp, and at McCurtain, Okla., by damming off the afterdamp and taking the top off a compressed air pump. In other cases men have retreated from the poisonous gases and lived several days to succumb just before aid reached them.

Some years ago experimenters in Europe found that a well-developed explosion traveled over 2,000 feet per second, hence the precursive wave will blow down almost any artificial structure opposing its movement. To construct artificial air stoppings sufficiently strong to withstand such a pressure would be too expensive. Instead, they should be so constructed that when the air is blown down it acts as a sort of safety or blow-off valve. In this case, therefore, explosion doors that could be blown open would be a goodly goal, and would relieve the pressure. It is also probable that explosion doors are not wrecked by being blown open, but are blown open by the column following the precursive wave. If explosion doors are blown out in the coal and duplicate doors

placed in them the recovery work would be greatly facilitated by making quick use of them to restore the ventilation.

In addition to explosion doors in entry breakthroughs there should be duplicate doors placed in recesses on every pair of cross-entries. This would give the men shut in the mine a chance to survive until help reached them. With the excellent arrangements of fan explosion doors and the location of fans to prevent their being wrecked by explosions, and the arrangements suggested, there can be no question but that the loss of life will be materially reduced should an explosion occur. It is also believed that economy will result in the end, for in some recent disasters the damage to the mines, together with other losses, has been many times that which the profits from coal can repay in one year.

If for any reason it is impracticable to comply at once with all the suggestions offered, it is possible to stop an explosion by keeping the walls of turnouts on entries saturated with water and that part of the entry or throats leading to them. The precursive wave expands on reaching a turnout; which means that its pressure is reduced and its speed is greatly retarded.

Supposing the area of the turnout is enough larger so that the expansion causes the pressure to decrease one-half; then, according to the formula, "the velocity varies as the square root of the pressure," if the previous velocity was 2,000 feet per second, it would at once be reduced to 500 feet per second. Volume, pressure, and temperature enter into problems of this kind, and since the wetted walls of the turnout and the increased volume would greatly reduce the temperature, it is probable that the velocity of the precursive wave would be reduced beyond the danger point and the flame extinguished, provided, of course, the turnout is sufficiently long and wet. There is proof that wet and enlarged entries have stopped the precursive wave and flame in several dust and gas explosions.

In compiling this paper the writer has not attempted to make a complete list of all the explosions that have occurred; in fact, it would be almost impossible to obtain a complete list there have been so many that were relatively unimportant; however, the most important in this country and one in France are listed in the accompanying table.

In looking over the list of explosions it will be noticed that the majority of them occurred shortly after the men had entered the mine to work. In several cases the origin of the explosion can be traced to the ignition of accumulations of gas. That so many disasters originated from gas explosions shortly after the men started to work casts a shadow of doubt regarding the integrity of the fire boss. Would it not be well, therefore, to ascertain how many places the fire boss can visit and investigate in a given time; and would it not be well for the foreman to occasionally quiz the fire boss and impress on him the necessity of keeping up the old adage, "What is worth doing at all is worth doing well?"

Assuming that the fire boss starts at the far end of the mine at 1:30 A. M. and reaches the entrance to the mine at 6:30 A. M. and reports every place safe. From the start to the finish 5 hours have elapsed, during which time it is possible that the barometer has fallen $\frac{1}{2}$ inch, or the pressure of the atmosphere on each square inch of coal face has decreased .245 pound. Some think that this is a negligible quantity not worth noticing, but the equilibrium of nicely balanced scales holding a heavy weight is upset by the addition of a grain, while in this supposed case there has been a decrease of 1,715 grains to upset the equilibrium. The circulation of air in rooms where men are at work and where cars are being moved is much more brisk than when those rooms are idle. This stagnant atmospheric condition in the rooms is favorable to propagating an explosion from a blown-out shot or from an explosion of dynamite or powder, because the chance for any gas to be diluted must be through diffusion, a slow process where there is no air in circulation. It seems probable, because of the sudden barometric fall during the latter part of March,

1912, that the inflow of gas in certain places where the air was not brisk at the Chant, Okla., and the Jed, W. Va., mines was the cause of those explosions.

Quite a number of the explosions on the list are known to have originated from shooting off the solid, or in using too much powder in the haste to break down coal. Referring again to the atmospheric condition of the room; when it is in a favorable condition to propagate an explosion, is it not advisable to warn the miners of the necessity of being careful of their mining on first entering their rooms and also to caution them against the dangers of shooting off the solid and handling powder shortly after going on shift?

A number of explosions on the list occurred just before noon or just before quitting time. In these explosions the propagating cause is attributed to gas and explosives. It may be inferred that the concussions due to promiscuous firing at this time raised an unusual cloud of dust; and that it was ignited by flame from a blast, or an explosion of powder due to careless handling. Mr. Stokes, in 1894, advised that "the remedial measures must be looked for in the initial start of the explosion," which is true; but if other precautions are taken, the devastation witnessed in past explosions will not be repeated. There are so many risks taken by miners and so many combinations happening in mines that nothing should be taken for granted.

PARTIAL LIST OF MINE EXPLOSIONS THAT HAVE OCCURRED IN THE UNITED STATES

Name of Mine	Time of Explosion	Date	Number Killed	Probable Cause and Remarks
Leisenring No. 2, Pa.	5:30 A. M.	February 21, 1884	19	Newly opened mine, said to be a gas explosion
Pochohtas, Va.		March 13, 1884	114	Dust
Lovedale, Pa.	7:00 A. M.	April 14, 1884	21	Gas
Youngstown, Pa.	1:00 P. M.	October 24, 1884	14	Gas
Newburg, W. Va.	2:45 P. M.	January 21, 1886	40	Gas
Uniondale, Pa.		March 8, 1886	7	Gas
Kettle Creek, Pa.		November 7, 1888	17	Dynamite started a dust explosion
Powers Mine, Pa.		May 10, 1889	4	Gas
Mammoth Shaft, Pa.	9:00 A. M.	January 27, 1891	109	Gas and dust
Berwind Shaft, Pa.		March 23, 1896	13	Gas and dust
Sunshine, Colo.	5:45 P. M.	September 3, 1897	12	Powder explosion, followed by dust explosion
Summer Mine, Pa.	5:30 A. M.	December 23, 1899	20	Gas and dust explosion of great violence
Red Ash Mine, W. Va.	7:16 A. M.	March 6, 1900	46	Dust
Scofield, Utah	10:34 A. M.	May 1, 1900	199	Gas and dust explosion, very violent
Berryburg, W. Va.	11:30 P. M.	November 2, 1900	14	Dynamite and dust on the main entry
Port Royal, Pa.	Evening	June 10, 1901	4	15 rescuers suffocated. Gas
Lost Creek, Iowa	11:55 A. M.	January 24, 1902	24	Blown-out shot, followed by dust explosion
Nelson, Tenn.		March 31, 1902	Large number	State mine worked by convicts third explosion
Fraterville, Tenn.	7:20 A. M.	May 19, 1902	184	Gas followed by dust
Johnstown, Pa.	11:30 A. M.	July 10, 1902	112	Gas and dust
Hanna, Wyo.		June 30, 1903	169	Gas and dust
Ferguson Mine, Pa.		November 21, 1903	17	Gas and dust
Harwick, Pa.	8:15 A. M.	January 25, 1904	178	Gas and dust
Eleanora, Pa.	9:30 A. M.	April 27, 1905	13	Gas and dust
Zeigler, Ill.	7:10 A. M.	April 3, 1905	53	Gas, dust, and carelessness
Coaldale, W. Va.	11:30 A. M.	January 4, 1906	22	Dust
Detroit Mine, W. Va.	12:28 P. M.	January 18, 1906	18	Dust and powder
Red Jacket, W. Va.	5:40 P. M.	February 1, 1906	3	Dust
Parral, W. Va.		February 8, 1906	23	Gas. 12 rescued
Century Coal Co., Pa.	4:30 P. M.	March 2, 1906	23	Blown-out shot and dust. Flame stopped by 100 feet of water
Courrieres, France	7:00 A. M.	March 10, 1906	1 100	Dust
Tidewater, W. Va.	3:00 A. M.	November 4, 1906	7	Dust
Panco Mine, W. Va.	6:30 P. M.	January 26, 1907	12	Powder and dust
Stuart Mine, W. Va.	5-6 P. M.	January 29, 1907	85	Gas and dust
Thomas No. 25, W. Va.	6:30 A. M.	February 4, 1907	24	Gas
Whipple Mine, W. Va.	3:30 P. M.	May 1, 1907	16	Gas
Naomi, Pa.	7-8 P. M.	December 1, 1907	34	Gas and dust
Monongah, W. Va.	10:30 A. M.	December 6, 1907	358	Dust
Yolande, Ala.	10:25 A. M.	December 16, 1907	56	Dynamite, gas, and dust; 30 escaped
Darr, Pa.	11:30 A. M.	December 19, 1907	230	Gas and dust
Primero, Colo.	4:30 P. M.	January 23, 1907	24	Gas and dust
Rock Springs, Wyo.		September 12, 1907		Runaway trip. Dust set on fire with naked lights. None killed, but 40 burned near the wreck
Marianna, Pa.	11:30 A. M.	November 28, 1908	154	Blown-out shot in a new mine exploded dust
Lick Branch, Pa.	3:00 P. M.	December 29, 1908	50	Powder and dust
Ellsworth Mine, Pa.		November 17, 1908		
Rosita Mine, Mexico		February 27, 1908	83	Blown-out shot and dust
Hanna, Wyo.	3:05 P. M.	March 28, 1908	18	Dust explosion. A second explosion at 10:30 P. M. killed 41 rescuers
Lick Branch, W. Va.	8:40 A. M.	January 12, 1909	65	Powder and dust
Wehrum, Pa.	7:40 A. M.	June 23, 1909	21	Powder and dust
Creek Mine, Ala.	11:00 A. M.	February 2, 1909	18	Dynamite and dust
Eureka No. 37, Pa.	4:30 P. M.	April 9, 1909	7	Dynamite blast
Franklin No. 2, Pa.	3:15 P. M.	October 31, 1909	16	Powder and dust
Orenda No. 2, Pa.	8:00 P. M.	January 25, 1909	5	Gas and dust
Bellevue Mine, Alberta	7:00 P. M.	December 9, 1910	30	Gas. Draeger men overcome
Palau No. 3, Mexico	3:30 A. M.	February 2, 1910	57	Gas
Starkville, Colo.	10:00 P. M.	October 8, 1910	55	Powder and dust
Primero, Colo.	4:30 P. M.	February 2, 1910	65	Gas and dust
Stearns, Ky.	9:30 P. M.	February 8, 1910	7	Shot off the solid in the main entry heading
Ernest, Pa.	7:50 A. M.	February 5, 1910	11	Dust and gas
Palau No. 2, Mexico	11:00 P. M.	September 30, 1910	78	Powder and dust
Delagua, Colo.	2:00 P. M.	November, 1910	79	Fire ignited dust
Browder Mine, Ky.		February, 1910	35	
Palos Mine, Ala.	1-25 P. M.	May 5, 1910	83	Powder and dust
Mulga, Ala.	9-10 P. M.	April 20, 1911	39	Gas and dust, although permissible explosives used and sprinkling in vogue
Banner Mine, Ala.	6-35 A. M.	April 8, 1911	128	Powder, gas, and dust. Ninety-six 30-gallon sprayers in this mine
Cokedale, Colo.	9:00 P. M.	February 9, 1911	15	Dust and dynamite
Sykesville, Pa.	Evening	July 15, 1911	21	Gas
Adrian, Pa.	7:00 A. M.	November 9, 1911	8	Dust
Bottom Creek, W. Va.	11:00 A. M.	November 18, 1911	18	Gas
Cross Mt., Tenn.	7:20 A. M.	December 9, 1911	86	Powder and gas
Merritt, B. C.	9:45 A. M.	March 7, 1912	7	Gas and dust
McCurtain, Okla.	9:39 A. M.	March 20, 1912		Gas (low barometer)
Jed, W. Va.	8:30 A. M.	March 26, 1912	82	Gas (low barometer)

New President of Lehigh Coal and Navigation Co.

Samuel D. Warriner, vice-president and general manager of Lehigh Valley Coal Co., has been elected president of the Lehigh Coal and Navigation Co., succeeding the late William A. Lathrop. Since Mr. Lathrop's death the office has been temporarily filled by Mr. Lewis A. Riley, a former president, now a

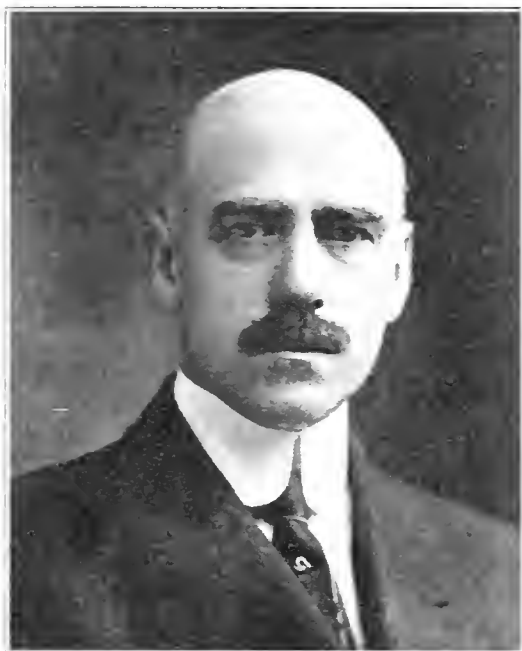

SAMUEL D. WARRINER, PRESIDENT LEHIGH COAL AND NAVIGATION COMPANY

member of the board of directors. Mr. Warriner is a graduate of Amherst College, where he received the degree of Bachelor of Arts, and of Lehigh University, where he received the degree of Engineer of Mines. He graduated from the latter institution in 1890. Immediately after leaving Lehigh he spent a few months in iron-ore mining in Virginia, when he went to Wilkes-Barre as mechanical engineer for the Lehigh Valley Coal Co. He made an enviable record in this position, and won the high esteem of his superior officer, the late William A. Lathrop.

Some 15 years ago he resigned his position with the Lehigh Valley Coal Co. to accept a more lucrative one with the Calumet & Hecla Co., in Michigan, where he added to his reputation as an able and forceful engineer and official. When Mr. Lathrop resigned as general manager of the Lehigh Valley Coal Co., in 1911, he recommended the appointment of Mr. Warriner as his successor. Mr. Lathrop's commendation, added to the recognized ability of Mr. Warriner, had such weight with the executive directors of the company that the appointment was made. As general manager his success was such that about 3 years ago he was promoted to the position of vice-president of the company.

Mr. Warriner, who is a Belgian, excelled, both as a student and as a professional man, in the same traits of study and vigorous action which have distinguished him in his professional career. He has been a member of the Board of Trustees of Lehigh University, and is now president of the Alumni Association. He is also a member of the American Society of Mining Engineers and the Board of Conciliation between the coal operators and miners.

As a person Mr. Warriner is his quiet dignity, an able and forceful man, and placed exterior under all circumstances. Mr. Warriner is a most agreeable man, firmly believing in the rights of other men, and constantly alert to

develop them by kindly assistance. He is greatly interested in any work that tends to raise the intelligence, and to socially improve the condition of the workingmen in his employ. His plans for furthering such work always include the cooperation of the men, as he rightly believes that without such cooperation on the part of the men themselves, uplift work is never successful, but tends rather to degrade and pauperize. In the selection of Mr. Warriner as executive head of the "Old Company" the Board of Directors of the Lehigh Coal and Navigation Co. has made a wise selection, and MINES AND MINERALS wishes the new president a continuation of the success he has invariably won in the past.

采采

A Deserved Promotion

Frederick M. Chase, general superintendent of the Lehigh Valley Coal Co., won deserved promotion, when at a meeting of the directors of that company, held on the 14th ultimo, he was elected vice-president and general manager to succeed Mr. S. D. Warriner, who resigned to accept the presidency of the Lehigh Coal and Navigation Co.

As a mere boy Mr. Chase entered the service of the Lehigh Valley Coal Co. in 1879, when the late Fred Mercur was general superintendent, and has been continuously connected with the general offices of the company, in Wilkes-Barre, Pa., winning successive promotions under Mr. Mercur, and his successors, the late William A. Lathrop, and Mr. Warriner, until in October last he was appointed general superintendent.

Mr. Chase is thoroughly familiar with all the various details of the thirty-four operations of the Lehigh Valley Coal Co., and from experience under three most capable superiors, in the 30 years of his connection with the company, he is well fitted to successfully manage its affairs.

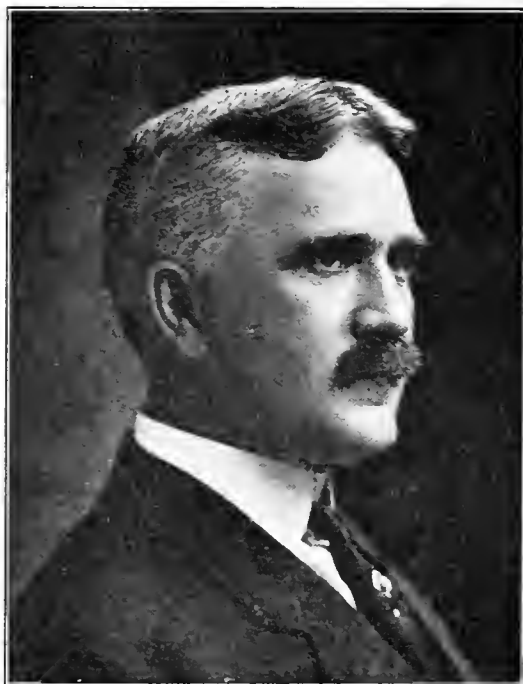

FREDERICK M. CHASE, VICE-PRES. AND GEN. MGR. LEHIGH VALLEY COAL CO.

In addition to his business qualifications, Mr. Chase has a pleasing personality and a kindly nature that has made for him hosts of friends both among the many employes of the company, and the other mining and business men of the anthracite region with whom he has been thrown in contact.

Here's success to Fred. Chase!

Hydraulic Filling in European Mines

The Dry Filling Method Formerly Used in Silesia, and the Hydraulic Method Now in Use

By L. Bucherer*

Continued from June.

When "siling" is employed in coal beds 3 meters thick the output is increased considerably under the following conditions:

The inclination varies from 18 to 25 degrees. Preparation is made by opening two benches with twin pipes, one on the bottom bench and the other above, as shown in Fig. 7. These pipes are connected every 50 meters by a cross-connection; and the two levels are joined by means of inclined planes on the bottom bench and 50 meters apart. The work is done in four benches of about 2 meters each. The lower one is worked as any ordinary seam. When the filling has settled, work on the second bench is begun, afterwards the third bench is mined, and finally the fourth one, abandoning the pipe on the bottom bench when filling the second bench. The inclined planes opened in the bottom bench must be raised to the second bench where the work is carried on, and so on to the third and fourth benches, and finally it takes the position shown in the elevation, Fig. 7. Every second inclined plane *p* is used for the transportation of coal, while the middle ones are used for the hydraulic filling pipes and as roadways by the men. The circulation of the air is shown by arrows *a* and the succession of the fillings of the different layers by numbers 1, 2, 3, 4.

With the hand filling, the third bench could scarcely be worked when the first was finished, while with the hydraulic filling the fourth is easily worked before the first one has reached the upper level.

A similar case occurred in the other coal beds, which are near one another. With the hand filling, very often the influence of the working in an upper or lower bed was noticed through rocks 40 to 50 meters thick during several months, thus causing, by the pressure on the filling, dangerous breaks on the top of the middle bench and tightening the coal to such an extent that the cost of mining was very much increased. With the hydraulic filling the work on the next coal bed could be started earlier and more systematically. As a very good practical rule the mining in one bed should not be done vertically, above nor below other excavations, as no unfavorable influence is noticed out of this zone.

This brings up the subject of the pressure in both kinds of filling.

The dry filling shrinks 50 per cent, and even more when attention has not been paid to filling with sand all the spaces between the pieces of slate. The hydraulic filling, as far as we have been able to notice, shrinks 10 per cent. In order to obtain more accurate information in a wider field—for in most cases the influence of the old hand filling system prevails—an exact leveling of the surface of the new plant was made, so that in a few years very accurate details will be obtained for every determined case, which, compared with those obtained in other mines under different conditions, will allow an exact calculation of each system of filling; the study of this question has not yet advanced very much in spite of its great importance in inhabited centers. It is easily understood that with hydraulic filling where slates thick enough have been used, or granulated dross, the compression is greater.

A very original procedure to diminish the influence of the cavities that were left with the hand-made filling in which big pieces have been used was applied in a mine in Westphalia where they had no convenient material for a complete hydraulic filling. They only had a layer of clay from 2 to 3 meters thick which they used for a hand filling made with the refuse from the

workings, leaving special space for the distribution of the clay. The results were as good as those of a complete hydraulic filling and it shows the great importance of the intelligent use of a material that generally is considered useless.

The methods adopted to carry the material into the mine are of great importance in the siling process.

In the shafts steel pipes are used ranging from 150 millimeters to 167 millimeters inside diameter and from 1 to 13 millimeters thick. In the workings the pipes are of the same diameter but lighter, from 316 to 470 millimeters thick. The sections are not screwed but bolted together, as it is easier to change them. Free unions, when they are well made, resist the pressure very well. Individually, I prefer the Manesmann tubes. As for unions, the ones of lead have given the best results, as they are non-corrosive and can be used almost indefinitely.

It was found that the Manesmann tubes were the most durable, especially in shafts. Good iron pipes, which are cheaper, were used in some shafts where the deterioration was not very great and where the breakage could easily be repaired. The greatest deterioration occurs in the shafts, and the pipes must be laid on a steep pitch. The greatest damage is caused by the stones that strike against the walls of the pipes and which take but a short time to perforate them. It is convenient, therefore,

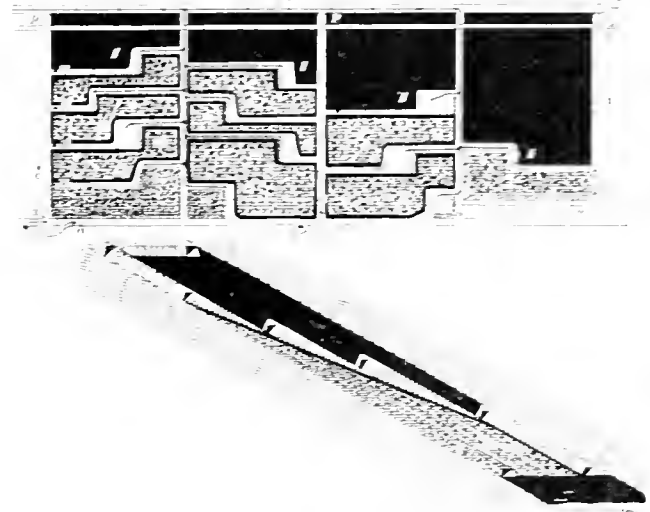

FIG. 7. PLAN AND ELEVATION

to have the pipes filled to a certain height, having in them as much mixture as they can contain, so as not to have a sudden fall but a continuous flow. On one occasion the pipes had to be replaced after having carried 45,000 cubic meters of filling, while on another occasion the same kind of pipes carried 260,000 cubic meters.

The last elbow of the pipe in the shaft is exposed to the greatest wear when this care has not been taken, and it was observed in the first experiments that the elbows made from the best steel, 40 millimeters thick, would not last more than a few hours. To prevent this deterioration, special elbows, either with changeable pieces of steel or with a concrete bottom, were employed, thus obtaining very good results.

This question of material for the tubes is very important for a rational application of the hydraulic system, because of its influence on the total cost. For this reason, from the very beginning engineers have tried to find some material stronger than steel and which could be changed without wasting the tubes. Special cast iron was tried, also glass, wooden paste, and mud, but without success. The only thing that gave good results when the filling was of sharp material, but free from stones, such as the granulated dross from the foundries, was a special porcelain made into tubes 50 centimeters long and 15 millimeters thick. These were fastened inside galvanized iron tubes with cement.

* Translated for MINES AND MINERALS from Informes y Memorias del Instituto Mexicano de Minas y Metalurgia.

Some mines in Westphalia receive their material from the neighboring foundries in the form of granulated dross—especially the "Deutscher Kaiser mine"—and this material reduces considerably the wear and the cost of the tubes. However, these tubes fail completely when the filling is made of sand that contains stones, because in many cases the porcelain does not last as long as 20 minutes. The last experiment with linings was made in the Klein-Rosseln mine with a special manganese steel, an alloy similar to that used in rock breakers. The results obtained will possibly be useful in the future; at present, however, there is no detailed information available by which to arrive at an exact idea of the reduction in cost.

For the horizontal pipes in the mines of Sajonia and Silesia, oval tubes with changeable linings on the lower side have been in use for 2 years. The advantage of these tubes is evident when one considers their application to drainage pipes. The tubes are kept cleaner than the iron ones and the mixture does not require so much water for flushing.

A comparison of the prices for 1 meter of tubing of 187 millimeters inside diameter is as follows:

	Marks
Iron, 33 millimeters thick	11 50
Mannesmann steel, 8 millimeters thick	14 16
With oval lining	23.00
With porcelain lining	25 26
With manganese steel lining	23.24

An important part of the pipe line is the gate valve for distributing the mixture to the different shafts. It is constructed in different ways, sometimes in the form of a gate and sometimes in the form of a revolving valve. Its construction is difficult, for with the pressure to be resisted and the velocity of the flushing material the slightest mistake in the construction renders a valve useless in a short time. In mines 400 meters deep it is necessary to resist a pressure of 40 atmospheres in the pipes when a stoppage occurs.

In order to clean the elbows and the other parts of the pipes a special valve must be used.

Factories specializing in mining supplies have devised different kinds of valves and special appliances, but without much success, notwithstanding that their devices are used in several mines. It is necessary to look for the simplest appliances in every installation, for when they are complicated, instead of being a help, they cause new interruptions when a difficulty occurs, and besides they get out of order easily.

For a good service in the hydraulic filling, it is necessary to have a telephone installation with only one wire, as the pipes may be used for the second conductor. The men working on the filling are provided with a portable apparatus which may be connected to the wire at any place.

In regard to the fluidity of the filling mixture, the observations following may be found serviceable:

A filling material having a fair proportion of pieces of every size and from 5 to 7 per cent. of clay has the best fluidity, and can be transported with great facility by using from 500 to 750 liters of water for each cubic meter of dry sandstone. The slate left from cleaning the coal or stones derived from the gravel having a diameter of from 5 to 6 centimeters are transported with some difficulty, and there have been cases in which 2 to 4.5 cubic meter of water were needed for each cubic meter of gravel; however, when they are mixed with sand in the right proportions, they have an adequate fluidity, which depends not on the size of the pieces, but on the good mixing of the different sizes, the water being necessary to fill up the cavities. The least excess of water is sufficient to make the material run, while more than one third is needed when there are only big pieces.

On an average, when the sandstone is thin, as is the case in the Klein-Rosseln mine, it may be calculated that 750 liters of water are needed for each cubic meter of dry filling, considering all the water necessary for cleaning the pipes before and after the operation. If one considers that the dry mixture may absorb

360 liters of water for each cubic meter, the excess that drains through the forms in these favorable conditions is not so important. Conditions are not the same when granulated dross or only broken stones are used, because the quantity of water is more than four times the volume of the filling and produces proportionate drainage expenses.

Mr. Nicol, in his very interesting paper on the building of forms for hydraulic filling, shows some coefficients with relation to the proper inclination of the chutes. To this the following is added relative to the chutes as well as to the pipes.

For granulated dross from blast furnaces: Inclination 1 : 5 with 4 cubic meters of water for each cubic meter of dry material. Inclination 1 : 3 with 2.5 cubic meters. Inclination 1 : 2 with 1 cubic meter.

For sandstone having different sizes in good proportion and running in full pipes: Inclination 1 : 100 with .5 to .7 cubic meter of water for each cubic meter of dry material.

This mixture runs with facility over each 1,000 meters of pipes absolutely horizontal and in some cases is forced upwards by the pressure of the shaft column. It was transported a distance of 1,700 meters and there is no reason why it cannot be transported still farther. In wooden semicircular chutes an inclination from 8 to 10 per cent. is needed; and it is advisable to lay the first sections of the pipes from the quarry to the pit on an inclination of 2 per cent.

A very important question is the clarifying of the water full of sand and clay. When there are old workings in which it can be settled it is not difficult. In other cases the best plan probably is to construct a special reservoir in a coal bed that cannot be exploited soon, or that will never be exploited on account of its poorness. By closing this reservoir with batteries, it is easy to clean the water because the sand and gravel will settle to the bottom. The reservoir should be divided into two independent parts, so that one may be cleaned now and again of the mud without interrupting the work.

The most suitable pumps for the drainage are the centrifugal ones, which force the water directly up into the tanks placed on heights, from where it comes to be used for a new operation. The mud is taken from the deposits in the reservoirs by means of pneumatic pumps, which throw it directly into old workings.

In spite of always having some old excavations ready to fill with the material coming from the preliminary workings, it is, however, difficult to transport and to do the filling when the mine is ready for the hydraulic filling.

Therefore, the waste material which cannot be used in nearby workings is taken to the surface in coal cars, and dumped into a stone crusher, where it is broken into pieces from 4- to 5-centimeters diameter. It is then transported to the quarry together with the waste from the coal cleaning. Compared with the total amount of hydraulic filling, this waste is very little; but it contributes to solidity of the filling and facilitates the drainage of the water. The cost of this filling, in spite of its apparent complication, is less by far than that of direct hand filling, for it must be considered that instead of originating a special service, it is entirely adapted to the existing one.

Where there is not sufficient sand, the hydraulic filling can hardly be applied, and unfortunately this happens often when the hydraulic filling is of the greatest importance for mining the security pillars under important towns, railroads, foundries, dams, rivers, canals, etc. The German government has understood very well the economic importance of this great national wealth and offered special reduced tariffs, almost as low as the cost price, for the transportation of the material by government railways, without obtaining by these means the sufficiently cheap sandstone to be used in the hydraulic filling. Therefore, this system cannot, particularly in Westphalia, reach the great development that it has in some favorable regions. It can only be applied at mines that are near extensive waste ground, as well

as the mines that are near blast furnaces, which are glad to get rid of their slag in this manner.

In order to get sandstone at a reasonable price, a special railroad 15 kilometers long, capable of transporting up to 3,000 cubic meters daily, was built in Silesia for the mines of "Koenigin-Louisen." The cost was as high as 2,000,000 marks.

The sand is taken out by means of two excavating shovels that work 200 and 300 cubic meters per hour, and is loaded into dump cars with a capacity of 40 tons. They weigh only 9.125 tons. The cars are unloaded on trestles, Fig. 8, near the shafts, which the train passes over, so not a moment is lost in reaching a maximum utilization of the material, which is an essential condition for a good output. The price of a cubic meter in the mines does not amount to more than .30 mark, all expenses included. Some

very extensive grounds to stack their slag, and in inhabited centers they have few opportunities to get this free space. In Westphalia, the blast furnaces are now selling their slag to the neighboring mines, but as yet they have some difficulty on account of the transportation and the tariff question.

In Klein-Kosseln the Burbacher-Huetten furnaces built a narrow-gauge railroad 10 kilometers long, which ran to one of the mine shafts, transporting the coal more economically than by the main railroad; for the future, the cars, instead of coming back unloaded, will go loaded with granulated slag, which mixed with sandstone will give a filling of superior quality. The foundry thus gets rid of the constant planning for the disposal of the slag, and on the other hand, the mining company will obtain for a long time the necessary amount of filling. Without this

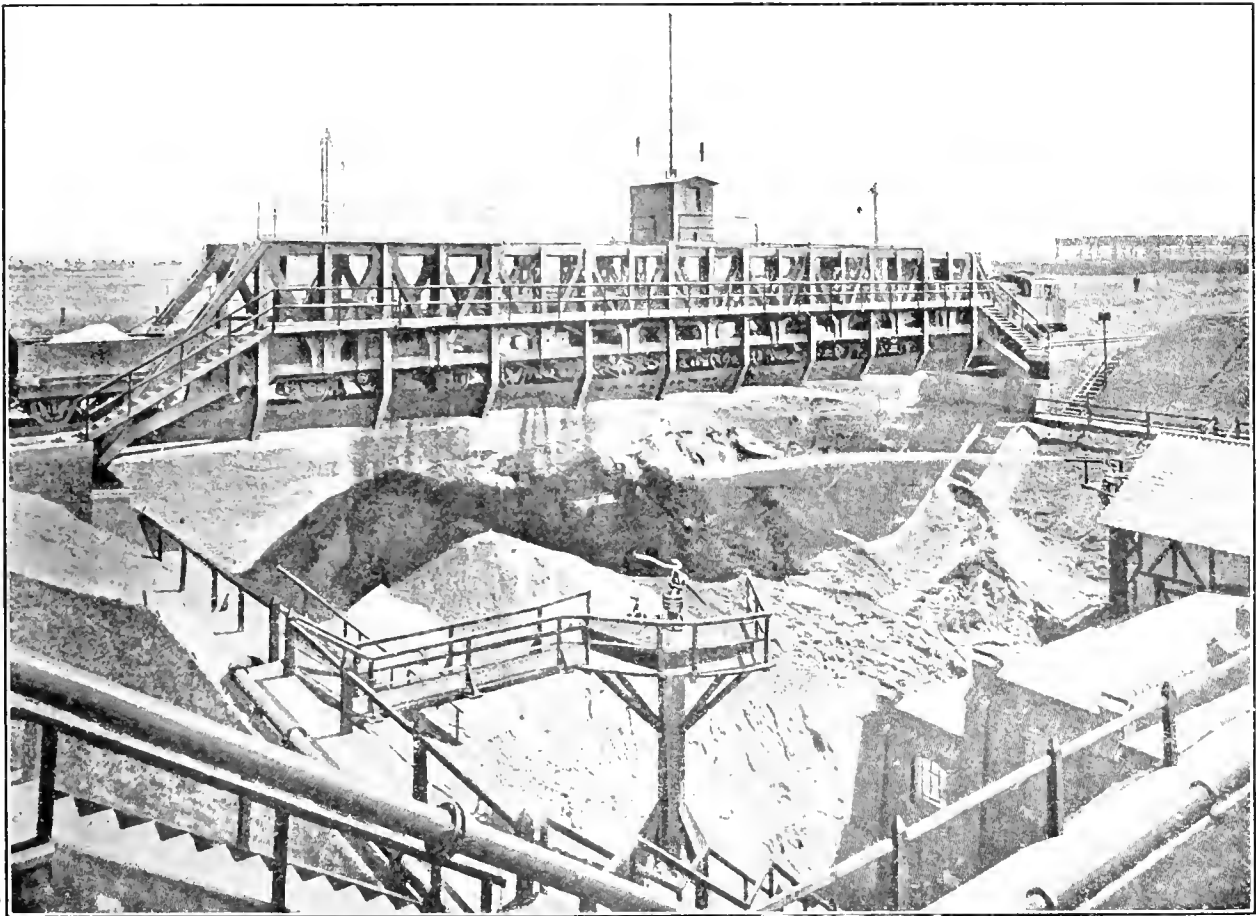

FIG. 8. HYDRAULIC FILLING AT KOENIGIN-LOUISEN MINE

private mines also established a company with a capital of 6,000,000 marks to build and run another railroad 27 kilometers long for the same purpose.

Another interesting case is that of "La Mure mine," in France, where the filling is done on a large scale, by working quarries of very hard stone; and to break this material quite an installation was necessary. These are the most disadvantageous conditions, but this method proved only a little more costly than that of hand filling, bettered the difficult conditions of this mine, made available more valuable coal, prevented mine fires, and increased the output.

Considering the enormous amount of filling material that a mine requires, it is advisable to take into account the quantity of material to be disposed of near the shafts, that does not require special installation for its transportation. In some instances, therefore, cooperation between iron furnaces and coal companies may be to their mutual advantage. The first require

arrangement, after about 10 years very expensive installations would be necessary to bring the sandstone from greater distances.

It may be a matter of surprise that no mention has been made of the direct forcing of the filling by means of water, as it is done successfully and at a very low cost for hydraulic works and other purposes.

The attempts made on this line failed, for the following reasons:

For the security of the work and the transportation in very long and complicated pipes, the regularity in the composition of the mixing, as well as the quantity, are of great importance, and are not possible by the forcing method.

Furthermore, it is always best to make the filling mixture as thick as the pipes will allow; with the hydraulic washing, on the contrary, a very diluted mixture is obtained which would seriously injure the work in the mines and would cause an excessive drainage.

On the other hand, the attempts at mechanical boring, which for many years had always failed in the soft sands—the hand drilling being more economical—finally succeeded, when using pneumatic hammers. Instead of hard strokes, this hammer gives light strokes, but very rapid, at the same time giving a rotary movement to the drill superior to that ordinarily used for hand rock drills. In soft gravel, the drill is made to imitate that of a carpenter's auger. With one hammer it is now possible to do the work of eight men; and after the success attained at the Klein-Rosseln mine, it was adopted at every mine of the Saarbrücken district where gravel is found.

Information relative to the extent and cost of hydraulic filling is given as follows:

In 1910 in the Klein-Rosseln mine, the total length of the pipes was 24 kilometers, the cost of which amounted to 720,000 marks. During the year 1908-9 400,000 cubic meters were filled, that is to say, an average of 1,300 cubic meters daily. The deterioration of the pipes varied according to the conditions, the years, and the plants, the cost averaging .10 mark for 1 cubic meter of filling.

The following is the cost of 1 cubic meter of filling:

	Mark
Taking the sand from the surface	.32
Deterioration of the tubes	.10
Interest on invested capital	.06
Miners' wages	.22
Cost of the batteries and other accessory works	.20
Horsepower for the drainage and crushers	.04
Total	.94

For each ton of coal used there is an average of .80 cubic meter of filling and an expense of .75 mark.

The Koenigin-Louisen mine has 35 kilometers of pipes and fills 3,000 to 4,000 cubic meters of space daily, making the record in this kind of work.

For the different mines for which information is at hand, the cost of the hydraulic filling for each ton varies from .60 mark to 2.10 marks.

The description of a special hydraulic filling to prevent a large inflow of water into a mine is a rather interesting application of the system:

In a new shaft of the Klein-Rosseln mine, mining was carried on in a vein 8 meters thick. At this mine the coal is covered by 160 meters of very watery sand and protected only by a cover of clay from 20 to 40 meters thick. The first layer, 8 meters thick, is formed by a conglomeration full of crevices, and rests on the coal bed; the middle layer is clay schist and only from $1\frac{1}{2}$ a meter to $1\frac{1}{2}$ meters thick.

Unfortunately in some places the protective cover of clay is missing, so that in spite of the protective coat the water came down full force through the layer of schists on the coal bed. The inflow of water began as an unnoticed filtration and increased so rapidly that after a few hours it reached 5,000 liters per minute. The management saw the impossibility of checking this stream of water with a concrete battery placed on the coal, and they anticipated the danger and injury that would be caused by the abandonment of this bed and by making a battery on the lower solid ground. Therefore, unless hydraulic filling was used to meet this situation, there was nothing else to do but to make the damage by means of pumps with an annual expense of about 1,000 marks.

To carry on the silting process a carefully constructed concrete battery was built in the excavation. This "wall," 30 meters high, was made in sections 3 meters long, the crevices in the wall were filled with cement. In the meanwhile, the water was allowed to pass through waste pipes in the battery. After being stopped by the concrete dam could resist the water pressure (about 100 meters) for some hours, pipes were connected with the outside of the battery of the best cement was mixed with 400 cubic meters of sandstone; 75 per cent. of this material was forced into the battery in a few hours, with an over-pressure corresponding to the difference between the density of the water

and the mixtures, as well as to the height of the normal level of the water. Under this pressure the mixture had to ascend to the crevices in the watery ground, and this pressure was maintained for two days, but using instead of the cement column another one of water and sand, so as not to lose the tubes. The final result was very satisfactory, as only 150 liters of water passed the filling per minute. The expense amounted to almost 36,000 marks, which was insignificant compared with what a continuous drainage would have cost.

來 來

Book Review

THE DESIGN OF MINE STRUCTURES, by Milo S. Ketchum, Dean of the College of Engineering, University of Colorado; 450 pages, profusely illustrated. McGraw-Hill Book Co., \$4, net.

While this work is intended primarily as a textbook, its contents cannot fail to prove of interest and benefit to the practicing mining engineer and superintendent. The first section of the book deals with what the author terms Headworks, a title made to cover head-frames, tipples, rock houses, and hoisting plants. The second section, called Mine Buildings, describes all sorts of framed structures about mines, such as roof trusses, bins, trestles, retaining walls, breakers, and washeries. The third section covers Costs of all these various mine buildings and structures. In addition to these three main parts of the book, there are a number of appendices treating on specifications for timber, steel, and reinforced concrete structures about mines. There are many photographs and detailed drawings of existing mine structures throughout the world. In the design of such affairs, the author has considered both the practical and the theoretical aspects and has accordingly introduced numerous stress diagrams for the analytical reader. So far as we are aware, this book has no counterpart in recent technical literature.

LABORATORY MANUAL FOR TESTING MATERIALS OF CONSTRUCTION, by L. A. Waterbury, C. E., 12mo., 270 pages, 68 figures, price \$1.50 net, cloth bound. Published by John Wiley & Sons, New York, N. Y.

The volume is particularly intended for the use of those schools which include in one course all of the work in testing materials which is required of their students. However, a sufficient number of problems are outlined to permit the manual to be used in those schools in which the work is subdivided into two courses. The Cement Laboratory Manual was prepared for the use of students taking the course in cement laboratory practice in the University of Illinois. Instructions for the problems originally used in the course mentioned were devised by Ira O. Baker, Professor of Civil Engineering, University of Illinois, under whose direction the author had charge of the cement laboratory at that institution.

In addition to general laboratory work there is an article on the Preparation of Reports, a description of the apparatus used, directions for making tests of cement and tests of concrete, also directions and problems for tests of iron and steel, wood, brick, sand, gravel, and stone; a chapter on tests of asphalt, which includes problems, purity of asphalt, penetration test of asphalt, residual coke in asphalt, loss in heating, and ductility of asphalt. The problems are presented as follows: The object of the test, the apparatus required, the materials required for testing, method of operation and report.

The book looks to be practical and also adapted to the needs of those interested in paving and concrete work.

TEXT BOOK OF CYANIDE PRACTICE, by H. W. MacFarren, author of "Practical Stamp Milling and Amalgamation" and "Mining Law for the Prospector, Miner, and Engineer," both of which books have been reviewed in MINES AND MINERALS.

The purpose of this book is to furnish students, cyanide workers, and those generally and technically interested in the subject, with a practical and technical exposition of the prin-

ciples and basic practice applicable to cyanidation in general, and not of the particular practice at any plant or locality. Mr. MacFarren goes to the root of things in a direct way, not beating about the bush, and consequently his books are all valuable to the student. As an illustration of this, take the last article, Prevention of Poisoning. "Cows are easily poisoned by drinking the diluted solution or moisture from the discharged residue or by licking the salts resulting from the evaporation of such moisture. Horses are not so often poisoned, and pigs very seldom. The addition of copperas, the commercial term for ferrous sulphate, or other cyanide to the moist tailing has lessened the trouble in this direction." We do not know of another cyanide book where so important, simple, and practical a paragraph is inserted. There are twenty chapters in the book, including a classified bibliography of the books and papers written on cyaniding.

The book contains 281 pages and index, and is published by the McGraw-Hill Book Company, New York, N. Y. The price of the book is \$3 net.

SUBWAYS AND TUNNELS OF NEW YORK, by Gilbert H. Gilbert, Lucius I. Wightman, and W. L. Saunders. This book is 8vo., 372 pages. It is profusely illustrated with figures in the text, and folding plates. The price of the book is \$4 net, and it is published by John Wiley & Sons, New York, N. Y.

From the preface it may be learned that the Island of Manhattan is a little less than 12 miles in length, and at the widest point a trifle over 2 miles in width; yet it is the business center of a population aggregating probably close to six millions. The census of 1910 credits New York City with a population of something over four millions, but when to this figure are added the inhabitants of the adjacent cities in New Jersey, New York, and Connecticut, which are within commuting distance, six millions is probably a fair estimate of the population, the business pivot of which is found in the Island of Manhattan. The actual business center for this vast number may be further restricted to a section south of 42d Street, the upper part of the island being principally residential.

Every business day in the year a vast tide of humanity converges on the business center of New York City. Throughout the business day a large percentage of these business men and women, and shoppers must be furnished quick and safe transportation within the limits of the island. Every evening this tide diverges to its homes. This morning and evening migration must be all accomplished within the space of an hour or so. The magnitude of the transportation problem here presented has called for the greatest engineering genius and almost unlimited capital, and its solution, by no means complete as yet, finds its beginning in the transit system of which the New York subway and the North and East River tunnels, with their connections, are a part.

The authors pay a tribute of admiration and respect to the genius and ability shown by the men who were the architects and builders of the tunnels under the river. To build and maintain tunnels through silt or other alluvial material, especially tunnels of large diameter, was a problem which had not been solved by engineers as late as 1874. At that time Mr. Delos E. Haskin came to New York from San Francisco, where he had made a fortune, every dollar of which he lost in an effort to prove the practicability of tunneling under the Hudson River and through the silt by means of compressed air. Though Haskin did not live to enjoy the fruits of his work, he proved the practicability of his scheme in a general way, and to him belongs the credit as the genius who pushed the idea to the front.

Next to him came Mr. Charles M. Jacobs, who combined the genius and enthusiasm of Haskin with the ability of the engineer. Mr. Jacobs built the first tunnel under the rivers about New York, namely, the East River Gas tunnel from New York to Brooklyn. After this he took up with enthusiasm the completion of the old Haskin tunnels, maintaining with earnest zeal the practicability

of the scheme, modified on lines of his own experience, until he succeeded in completing these and the Pennsylvania tunnels, which are described in detail in this volume. Mr. Jacobs has now returned to his home in England, and well does he deserve the reputation and wealth which he has achieved. Mr. William G. McAdoo, with great foresight and ability, planned and executed that gateway to New York, through tunnels under the Hudson, which is called the McAdoo System. Of these three men, Haskin was the enthusiast, Jacobs the engineer, and McAdoo the business man.

The book contains a great deal of useful information relative to the costs, method of working, etc. It contains 21 chapters and 14 appendices.

BOOKS RECEIVED

UNITED STATES GEOLOGICAL SURVEY PUBLICATIONS, WASHINGTON, D. C. Bulletin No. 471-A-1, Advance Chapter from Contributions to Economic Geology in 1910, Part II, Mineral Fuels, Petroleum, and Natural Gas in Kentucky, by M. J. Munn; Bulletin No. 471-A-2, Advance Chapter from Contributions to Economic Geology, 1910, Part II, Mineral Fuels, Petroleum, and Natural Gas in Alabama, by M. J. Munn; Bulletin No. 471-A-3, Advance Chapter from Contributions to Economic Geology, 1910, Part II, Mineral Fuels, Petroleum, and Natural Gas in Wyoming, by C. H. Wegemann; Bulletin No. 471-A-4, Advance Chapter from Contributions to Economic Geology, 1910, Part II, Mineral Fuels, Petroleum, and Natural Gas in Utah, by E. G. Woodruff; Bulletin No. 492, The Gabbros and Associated Rocks at Preston, Conn., by G. F. Loughlin; Bulletin No. 530-P, Zirconiferous Sandstone Near Ashland, Va., by Thomas L. Watson and Frank L. Hess; The Production of Fuller's Earth in 1911, by Jefferson Middleton; The Production of Bauxite and Aluminum in 1911, by W. C. Phalen; The Production of Monazite and Zircon in 1911, by Douglas B. Sterrett; The Production of Sand-Lime Brick in 1911; The Production of Graphite in 1911, by Edson S. Bastin; The Production of Talc and Soapstone in 1911, by J. S. Diller; The Production of Mica in 1911, by Douglas B. Sterrett; The Production of Slate in 1911, by A. T. Coons; Water-Supply Paper No. 279, Water Resources of the Penobscot River Basin, Maine, by H. K. Barrows and C. C. Babb; Water-Supply Paper No. 285, Surface Water Supply of the United States in 1910, Part V, Hudson Bay and Upper Mississippi River, by Robert Follansbee, A. H. Horton, and G. C. Stevens.

UNITED STATES DEPARTMENT OF AGRICULTURE, WASHINGTON, D. C. Bulletin No. 106, Wood-Using Industries and National Forests of Arkansas, Part I, Uses and Supply of Wood in Arkansas, by J. T. Harris, Statistician, and Hu Maxwell, Expert; Part II, Timber Resources of the National Forests in Arkansas, by Francis Kiefer, Forest Supervisor.

來 來

Obituary

THEODORE ALBERT

Theodore Albert, president of the William Powell Co., Cincinnati, Ohio, who for years gave his personal attention to the production of the steam specialties manufactured by that company, and who was well known throughout the mining field, died at his home in Cincinnati on May 27, last.

JAMES M. TURNER

James M. Turner, inside superintendent of the Alden Coal Co., died at his home in Alden, Luzerne County, Pa., on the 14th ult., aged 62 years. Mr. Turner was a native of Somersetshire, England, and came to America when 19 years old. He began work in the mines in England when but 10 years of age. Shortly after coming to America he located at Nanticoke, Pa., and secured employment in the mines of the Susquehanna Coal Co. For 21 years he was mine foreman and inside superintendent for the Susquehanna Coal Co., resigning in 1898 to accept a similar position with the Alden Coal Co.

Improved Coke Oven Practice

Use of Crushed Coal, Electric Pullers and Loaders and Leveling Machines

With the introduction of electric power and the desire to economize wherever possible, beehive coke making has made some slight advancement since 1891. At this date possibly 150 patents for improvements in beehive ovens had been issued, none of which, however, materially changed the existing conditions. One serious drawback to beehive ovens was the repairs made necessary by the gradual sinking of the oven crown. In a measure this was overcome by changing the hemispherical shape to one resembling the end of a navel orange, that is, slightly oval. This lengthened the life of the oven crown without detracting from its radiating ability; however, the shape must not be too exaggerated or holes in the crown will occur near the trunnel head. In the Pocahontas field if the coal charged into the ovens

Connellsville coke have been considered the physical tests of good coke; however, it is not the only test, for if it were the product of retort by-product ovens would decrease instead of increase. Watering on the yard blackens the surface of coke, and again makes the consumer unnecessarily doubtful of its quality. There might be some reason in this, as an inferior article could be shipped if coke producers were unscrupulous; however, each operator is striving in every way to increase his trade and hold his customers, so there is little likelihood of its occurring. If coke was injured by watering on the yard, the production of retort-oven coke would be on the decrease instead of the increase. The ideas originating in the Pennsylvania coke field relative to lustre and ring making coke more valuable to the consumer have acted like a boomerang to the industry, so far as economy in coke production is concerned, for they have prevented mechanical loading being introduced, which would have saved at least 10 cents per ton over fork loading, besides watering inside is wearing on the ovens. In Fig. 1 is shown a combined coke drawer and coke loader used at the Continental coke plant of the H. C.

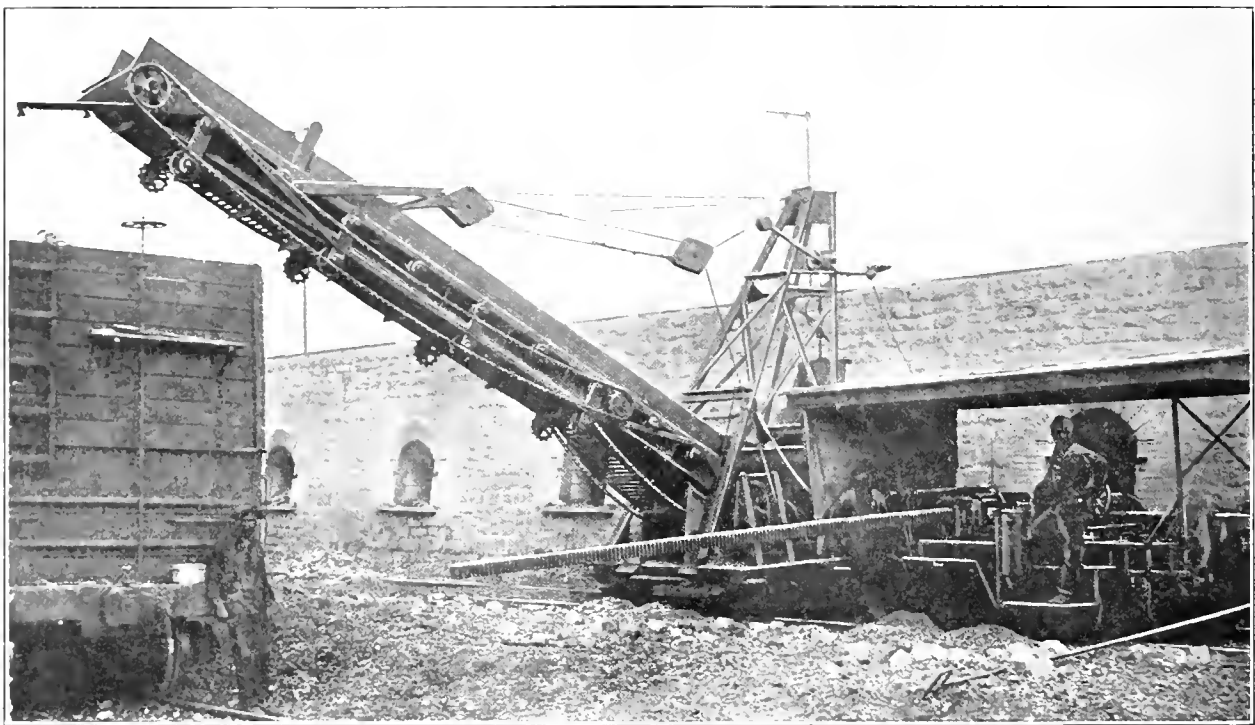

FIG. 1. ELECTRICALLY OPERATED COKE DRAWER AND LOADER

was of varied sizes, it did not always coke uniformly. This was owing to the small quantity of volatile matter in the coal and to the ovens cooling too far. For this reason, and to obviate loss from handling, the Crozer Coal and Coke Co., in 1893, constructed a roll crusher to reduce all coal to be coked to a small uniform size. The coke made from the crushed coal was uniform in cellular structure, tough and compact, formed less coke breeze, and did not break as readily when forked as the coke from uncrushed coal. While this was better in many ways than coke from uncrushed coal it was condemned at first by consumers because it was compact, did not ring particularly when rapped, and its appearance was not silvery.

At the Pocahontas, Warren Delano and Robert A. Cook attempted to improve the Newton-Chambers beehive by-product oven, and for that end a small plant was built at Latrobe for experimental purposes. At this plant the first mechanical coke drawer for beehive ovens was introduced. While the ovens were being repaired the coke drawer was adopted by the Pocahontas plant, and, with power modifications, is in use at a number of plants today. The silvery look and the ring of

Frick Co. and at the ovens of the United States Coal and Coke Co., Gary, W. Va. The machines are electrically driven and are equipped with traction gearing so that they can be moved from oven to oven without difficulty. The coke is watered inside by an improvement over the old watering pipe, and after it is considered quenched, the machine which moves the rack *b*, Fig. 2, extending from the rear of the truck, is set in motion. At the oven end of the rack arm is an arrow-headed plow, or hoe, *a*, which enters the oven and breaks the coke which falls back of the wings of the arrow. When the arm is withdrawn the hoe pulls out the coke which falls on a platform moving toward the crane, shown in Fig. 1, extending over the car. On the crane arm is a conveyer line which carries the coke above the car so that it falls into the car. In several cases to prevent breakage, baskets catch the coke and lower it in the car. Another improvement worthy of mention is the electrically driven machine which levels the coal after it has been charged in the oven. This was described in Volume 30, MINES AND MINERALS. One of these machines will level coal in 200 ovens, and as they do it from the top through the trunnel head the doors can be bricked and

daubed even before charging, thereby retaining the heat in the oven. Nearly all the available coking heat in beehive ovens is reflected heat. The flame from the volatile matter of the coal is absorbed by the firebrick to some extent, but it is the heat radiated from the incandescent coal and reflected from the hot bricks back to the coal, which causes the intense heat of the beehive oven. The bricks also act as regenerative stoves, and after an

mines were worked to the limit and the catastrophes, caused by firedamp, increased in an alarming manner. In fact the distress was so great that in 1812 a society for the prevention of mine disasters was formed at Sutherland, and the origin of the safety lamp can be traced back to the efforts and labors of this organization. Dr. William Reid Clanny, a retired ship's surgeon, was probably the first to undertake the task (in the year 1808), which he successfully finished with energy and skill. He concentrated his efforts at first on the separation of the flames from the surrounding atmosphere, but he did not succeed till the latter part of 1812, when he constructed a lamp that seemed to meet all requirements. The report of this invention was submitted to the Royal Society of London, May 20, 1813, and was printed in the minutes of that academy. The casing of this original safety lamp was closed at the top and bottom by two open water tanks; the air was pumped in by means of bellows and, passing in and out, had to go through both these reservoirs which acted as valves, so to speak. The lamp proved to be absolutely safe and was successfully introduced by the management of Herrington Mill pit mine. The clumsy parts of this apparatus were eliminated by its inventor by various improvements. The so-called steam safety lamp was completed in December, 1815, and installed in several mines. In the meanwhile, two competitors made their appearance. George Stephenson had finished his lamp October 21, 1815, and Davy published his first experiments November 9, 1815, in the Transactions of the Royal Society of London. Clanny's lamp, nevertheless, stood the test in the face of this competition, through its much superior illuminating power, and more particularly as it still continued to burn when the Davy and Stephenson lamps had gone out. To Clanny, therefore, belongs the distinction, in the history of invention, of having constructed the first reliable safety lamp.

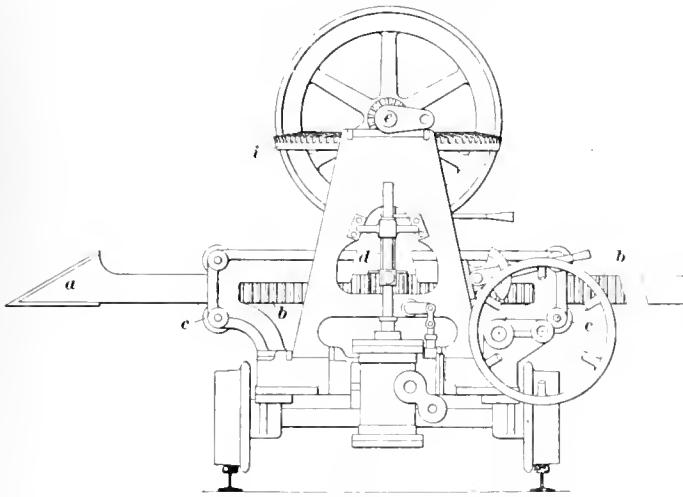

FIG. 2

oven has been charged and the doors bricked up, will reflect sufficient heat to start coking operations anew. Of course should the bricks be exposed to cold air too long a time they will lose so much heat they cannot radiate sufficient heat to fire the charge. The hotter the ovens are kept the better will be the coke produced in a given number of hours.

來 來

History of the Safety Lamp

The safety lamp, the miner's faithful and indispensable companion at his dangerous work, has been, heretofore, considered as the invention of the famous English scientist, Humphrey Davy, though the name of George Stephenson, of locomotive fame, has also been mentioned in this connection. Both came out with their invention about the same time, but neither of them is the real inventor of the safety lamp; for there was, as proven by Wilhelm Nieman, a safety lamp in existence 2 years before Davy's invention became known. It was not inferior to the latter, but rather surpassed it in illuminating power. Previous to this, all the precaution employed for the prevention of the threatening dangers of firedamp had been quite incomplete. One tried to thoroughly ventilate the mines by fastening a burning torch to a large pole, which was pushed ahead and exploded the gases. This was extremely dangerous work which, in the Middle Ages, was generally done by a criminal, in order that he might atone for his crimes, or by a penitent for the benefit of mankind. The attempt to substitute for the open light phosphorescent substances, encased in glass, was not much of a success. An improvement was the so-called steel mill, invented about 1750 by Carlyle Spedding, manager of a mine. This steel mill consisted of a steel wheel which was put into rapid motion by means of a crank. By pressing a firestone against the fast revolving wheel, an incessant shower of sparks was produced, giving a fairly good and absolutely safe illumination. However, the running expenses of his apparatus, which necessitated the continual services of one man, were very high; for instance, the expenditure for light in a coal mine near Newcastle in the year 1816 amounted to about \$200 per week. Nevertheless, the steel mill was very much appreciated and in use for a long time, only to be slowly supplanted by the safety lamp.

At the beginning of the nineteenth century the existing coal

來 來

Using Electric Power on a Steam Hoist

While in many industries machines would be scrapped, in mining they are frequently converted to usefulness about the plant. An illustration of this kind has been sent MINES AND MINERALS by A. A. Galloway, of Trinidad, Colo. The problem was the connection of an electric motor to a hoist which formerly used steam as the motive power, and the method adopted in accomplishing this is shown in Fig. 1.

The countershaft of the hoist is lengthened to carry a gear and boxing by the simple device of bolting to the disk of the

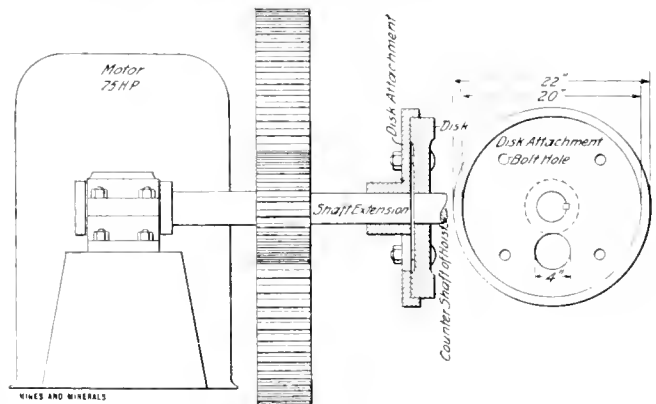

FIG. 1. CONNECTION FOR HOIST AND MOTOR

countershaft the additional length required. The gear is necessary to reduce the high velocity of the motor to a workable velocity of the drum. A casting is made which fits snugly over the outside of the disk, and in this casting are four bolt holes so that it may be firmly bolted to the disk; also in this casting a 4-inch hole is made to allow clearance for the crank-shaft stud. Both gear and disk attachment are keyed to the shaft extension.

Answers to Examination Questions

Questions Asked at Examination for Mine Foremen, Utah,
October, 1911

QUES. 1.—Name and describe the instruments used in examining the condition of the atmosphere of a mine, showing the application of each.

ANS.—The instruments generally used for this purpose are the safety lamp for determining the existence of marsh gas; the anemometer, together with a tape, for measuring the volume and velocity of the air-current; the psychrometer, or hygrometer, for determining the percentage of moisture in the air, and the barometer for measuring the pressure of the atmosphere. In certain cases, although not instruments in the ordinary sense, mice or canaries are used to ascertain the presence or absence of small quantities of carbon monoxide.

The safety lamp is based upon the principle that a mixture of marsh gas and air will not, under ordinary conditions, communicate the flame of their combustion through a wire gauze, or netting. The lamp consists of a chamber to carry oil or other burning fluid, and provided with a wick, the wick being surrounded by wire gauze only (the Davy lamp) or with glass and gauze (the modern lamp). Air for combustion enters through special passages, or through the gauze itself, and while, if gas is present in sufficient amount, there will be a burning within the lamp itself, yet the flame is so cooled by the gauze that it is not communicated to the mixture of gas and air outside the lamp. The percentage of marsh gas present in the mine air may be roughly estimated by the "cap," or flame of burning gas which extends above and forms a cap upon the ordinary flame of the lamp. However, if the lamp is carelessly handled, or the gauze is perforated, or the mixture of gas and air is allowed to burn within the lamp until the gauze is overheated, flame sufficient to cause an explosion may be transmitted to the outside air.

The anemometer consists of a series of blades or vanes fixed upon an axis, which may revolve, the whole enclosed in a metal frame. The blades are so arranged that one revolution of the anemometer corresponds to 1 foot of travel of the air-current; the number of revolutions being recorded on a dial or series of dials. The anemometer is held in the air-current for any convenient number of minutes (usually 2 or 3) which is determined by a watch, when the reading of the dials will give the number of feet traveled by the air in this length of time. The total distance divided by the number of minutes the anemometer was in motion will give the number of feet traveled by the air in 1 minute, in other words, the velocity; as 1 minute is the unit of time in estimating velocities in problems concerned with ventilation. The area of the airway in square feet is determined by measuring its height and width with the tape, and this area multiplied by the velocity as recorded by the anemometer, gives the volume of the air-current in cubic feet per minute.

The hygrometer, or psychrometer, is based upon the principle that in the process of evaporation heat is extracted from surrounding objects; that the higher the temperature and the dryer the air, the more rapid the evaporation; and that this abstraction of heat may be measured by a thermometer. The instrument, which is now in general use in mines producing explosive dust, consists of two delicate thermometers mounted side by side in a wooden or metal frame so that they may be carried from place to place. One of these thermometers, known as the "dry bulb," differs in no way from an ordinary thermometer. It is used to give the temperature of the air in the usual way. The other thermometer, known as the "wet bulb," is identical with the dry bulb in every way, but its lower end is surrounded with a wick of porous cotton, the bottom of which is placed in a small jar of water fastened to the same frame as the other thermometer. Owing to the porosity of the

sack or wicking, the water in the jar is absorbed and the lower end of the wet bulb is surrounded with cotton cloth saturated with water. According to the dryness of the air, the water is evaporated with greater or less rapidity, and heat is abstracted from the wet bulb, which indicates a lower temperature than the dry bulb. The difference in the temperature as indicated by the dry and wet bulbs is a measure of the "relative humidity" of the air. Air at any temperature will contain a certain definite amount of watery vapor. At a higher temperature it will contain more, at a lower temperature, less. When air contains all the moisture it will hold at a certain temperature, it is said to be saturated. Relative humidity is the ratio of the amount of moisture actually present in the air to what it would contain if fully saturated at the same temperature, this relation being expressed as a per cent. Thus a relative humidity of 100 per cent. means that the air is carrying all the moisture it can at that particular temperature. In such a case, there can be no evaporation and readings of the wet and dry bulb will be the same, but as air is rarely fully saturated, the wet bulb generally gives a lower reading than the dry bulb. There are various forms of this instrument, the most common for mine use being known as the "whirling" hygrometer. In this instrument, the two thermometers are mounted on a narrow plate of metal, to the upper end of which is affixed an iron handle, or sling, so that the hygrometer may be whirled or rapidly revolved, thus assisting evaporation. It is generally revolved for a minute or more, the operation being repeated until constant readings are obtained. Another form is known as the "hygrodeik." In this, the two thermometers are mounted on a plank, and between them is suspended a long movable arm with a small finger sliding along it. The plank is arranged with a series of intersecting curves, the shape or form of which are dependent upon the readings of the wet and dry bulb, respectively. Through the points of intersections of these curves are drawn other lines, the lower ends of which are marked to correspond with the relative humidity as shown by the readings of the two thermometers. The finger on the arm is fixed on the curve of temperature as indicated by the wet bulb, and moved along until it intersects the curve from the dry bulb, when the relative humidity may at once be read off at the end of the arm. While probably not as accurate as the standard form of hygrometer, the hygrodeik is very convenient, in that it requires no calculations or no reference to tables in order to obtain the humidity. The chief value of the hygrometer consists in that by its means we are enabled to tell when increased watering is necessary to lay the dust, and, approximately at least, the amount of water necessary for the purpose. Knowing the volume of the air-current and the mean temperature of the mine, it is possible to prepare a table showing the number of gallons of water per minute required to saturate this volume of air. As long as the humidity is 100 per cent., that is, as long as the air is saturated at the mine temperature there will be no absorption of moisture from the dust in the mine; and if this dust has previously been thoroughly moistened, it will remain so, and a dust explosion is not generally possible. On the other hand, when the humidity falls below 100 per cent. water begins to be absorbed from the workings, while absorption is continued until the air is saturated. The mine thus dries out and a dust explosion is possible. Knowing the amount of water required to saturate the air-current at the mine temperature and the amount actually brought into the mine, the difference is the minimum amount which must be supplied artificially in order to keep the dust in a proper condition of safety. While these figures are, naturally, not absolute, they form a valuable clew as to whether one or five sprays should be turned on, or whether the water car must be run over the headings more than once.

The barometer is based upon the principle that the weight of a column of air of the height of the atmosphere will balance the weight of a column of mercury (quicksilver) of a lesser

height. At sea level under normal conditions, the height of the column of mercury which will balance the weight of the atmosphere is about 30 inches. As the barometer is moved to higher or lower altitudes, or as weather conditions change, its readings decrease or increase; that is, it is said to "rise" or "fall." The barometer, then, is a measurer of pressure of the atmosphere; the greater the pressure, the higher the barometer, and vice versa. The instrument consists of a glass tube filled with mercury, the upper end being closed and the lower open. The tube is inverted and the open end placed in or connected with a small receptacle containing mercury. Alongside the tube is a scale graduated in inches and tenths, smaller divisions being read by means of a vernier. At any given place the barometer has an average height or reading depending upon the elevation above sea level, the latitude or distance north or south of the equator, the general atmospheric conditions prevailing, etc. All gases are extremely sensitive to changes in pressure. Consequently, when the barometer falls below the normal, or average of the place, the decrease in pressure will permit, in fact will cause, an outflow of gas from the old workings or gob into the mine. On the other hand, if the barometer rises, indicating an increased pressure, gas is driven back into the gob. A fall of the barometer, then, indicates the need of increased precautions in handling the ventilation of the mine, owing to probable influx of an unusual volume of gas into the workings. Naturally, a rise in the barometer indicates safe conditions which require no more than the ordinary care.

The most dangerous gas met in mines is carbon monoxide, or CO , because it is an active poison, even in extremely small amounts. Dangerous amounts cannot be detected with the safety lamp, although this instrument is a guide to its presence in quantities that might cause an explosion. Mice and canaries are very susceptible to the influence of this gas, far more so than men, and it is customary at some mines and at most rescue stations to keep a supply of these animals on hand for the purpose of testing the mine air for CO . Where they will live, men are safe; where they die, men should leave at once.

QUES. 2.—A mine is giving off 2,500 cubic feet of marsh gas, CH_4 , per minute; the amount of air for ventilation is 4,500,000 cubic feet per hour. (a) What is the per cent. of gas in the air-current? (b) Would you consider this percentage of gas dangerous or not?

Ans.—(a) 2,500 cubic feet of gas a minute equals $2,500 \times 60$ or 150,000 cubic feet per hour. The total volume of gas and air then would be $4,500,000 + 150,000 = 4,650,000$ cubic feet. The percentage of gas in this mixture would be

$$\frac{150,000}{4,650,000} \times 100 = 3.33 + \text{per cent.}$$

(b) While this proportion of gas and air does not in itself constitute an explosive mixture, it indicates an extremely dangerous state of affairs, particularly in a mine containing even a comparatively small amount of coal dust. An amount of dust, which alone would probably not propagate an explosion from a blown-out, or windy, shot, from a mine fire or an electric arc, will, in the presence of such an amount of gas as this, extend the effects of an explosion throughout the mine.

QUES. 3.—If in entering a room where gas feeders are found you came across a man using his safety lamp to fool or play with the gas, what action would you take?

Ans.—The man should not be startled, but should be told gently to lower his lamp or take it away from the feeder. After the lamp ceases to be an immediate source of danger procedure would vary. A mine foreman of the old school would probably knock the man down with his fists or the first available pick handle. While no treatment seems too severe for a man who will deliberately imperil the lives of all his fellow workmen by "playing" with gas, yet the pick handle, although a good remedy, is not the legal one. The man should be immediately sent from

the mine, paid off, and sent out of the camp. If possible, criminal proceedings should be started against him, to be followed by conviction and a long term of imprisonment. Our laws are too lax in such matters and too much discretion is left to the intelligence (?) of the judge. There have been instances where different men for the same offense (so the printed records show) have been fined \$1 or imprisoned for from 3 to 6 months, or even dismissed with a mere reprimand. Any action endangering life should be regarded as a criminal one, to be followed by imprisonment, and not as a mere misdemeanor, which leads to a fine only.

QUES. 4.—As foreman, if you should find any one of your fire bosses predated the working places in his district, what would you consider your duty?

Ans.—If discovered before the men have gone in, an immediate inspection should be made and the men kept out of their places until the face is reported safe. If the men are at work at the time, it would seem best to first visit the places known to be the most gaseous and send the men back from the face until an examination has been made. The men in the least gaseous rooms could be warned of the possible danger and ordered back until some one has time to make a proper examination. The fire boss should be instantly discharged and his certificate suspended or cancelled.

QUES. 5.—What quantity of coal is contained in a tract of coal of 250 acres, the seam being 22 feet thick and pitching 50 degrees?

Ans.—It is necessary to assume that the entire tract is underlain with the coal. As the specific gravity of the coal is not stated it may be assumed to be 1.35. It is necessary to first find the weight of the coal under the tract if the seam was horizontal. The weight per acre is found by multiplying together the number of square feet in an acre by the thickness of the seam and this by the weight of a cubic foot of water and the specific gravity of the coal; the whole being divided by 2,000 to reduce it to tons. This result when multiplied by 250 gives the number of tons in a horizontal bed of this size. $250 \text{ (acres)} \times 43,560 \text{ (square feet in acre)} \times 22 \text{ (thickness of coal)} \times 62.5 \text{ (weight cubic foot of water)} \times 1.35 \text{ (specific gravity of coal)} = 20,214,562,500$ pounds of coal in 250 acres of coal 22 feet thick if the seam were horizontal. This sum divided by 2,000 (number of pounds in 1 ton) = 10,107,281.25 tons.

As the seam is on a pitch, the amount of coal is inversely proportional to the cosine of the angle of dip, because in a right-angled triangle, the hypotenuse, which is the extent of the bed along the line of pitch, is equal to the "side adjacent," which is the length of the coal along the level, divided by the cosine of the angle, in this case, the angle of dip. We then have, $\frac{10,107,281.25}{.64279} = 15,724,080$ tons of coal under a tract 250 acres in extent when the seam is 22 feet thick and pitches 50 degrees.

QUES. 6.—In operating an electric motor in the mine, using track rails for return current, being certain that the transmission wires had sufficient carrying capacity, when motor started and before reaching full speed, the voltage would drop with very high amperage and the motor would not pull its full load before the lights would almost go out, where would you look for the trouble?

Ans.—The trouble is caused by imperfect bonding and is a very common one in electric mine haulage. Altogether too frequently the bonding is looked upon as a necessary evil to be done as roughly and cheaply as possible, forgetful of the fact that proper bonding, well done at the outset and well maintained thereafter, is just as essential to economic haulage as good sized feed-wires, ample power in the motor, well-laid track and good rolling stock. Mine haulage has outgrown the road beds in use, and mine managers seem to forget that trains of 40 or more cars, each weighing with its load from 3 to 5 tons, cannot be hauled at speeds of from 20 to 30 miles an hour in safety, economic or

otherwise, upon light, poorly bonded rails laid on a crooked road bed.

QUES. 7.—If the bearing of the main slope is $N 5^{\circ} 30' E$, what is the bearing of the sixth west entries, the entries being turned at an angle of 85° ?

ANS.—The entries are evidently in the northwest quadrant and are turned to the left from the slope. The rule is, when the first two letters of the bearings are the same and the last two unlike, to add the values of the bearings to find the angle between the lines. In this case, we wish to find the bearing, the angle being given, so we subtract, thus, $85^{\circ} - 5^{\circ} 30' = 79^{\circ} 30'$. As the bearing is in the fourth or northwest quadrant, the direction of this pair of entries is $N 79^{\circ} 30' W$.

QUES. 8.—If the direction of the rooms is $S 14^{\circ} 30' E$, what angle do they make with the sixth west entries as above?

ANS.—We found the entries to have a bearing of $N 79^{\circ} 30' W$. This is, of course, the same as $S 79^{\circ} 30' E$. As the rooms have a bearing of $S 14^{\circ} 30' E$, the lines are in the same quadrant and all four letters are alike. The angle between the lines is the difference of their bearings, or $79^{\circ} 30' - 14^{\circ} 30' = 65^{\circ} 00'$. This is the acute, or sharp angle made between the entry and the rooms. The other angle, the obtuse, or flat angle, is found by subtracting the one just found from 180° , or $180^{\circ} - 65^{\circ} = 115^{\circ}$. This last, in looking inbye toward the face of the heading, is the true angle between the entry and its rooms, which, it is apparent, are opened by back switches.

QUES. 9.—What methods would you adopt to prevent the occurrence of blown-out shots?

ANS.—The coal should be undercut to a depth at least equal to the length of the shot hole and preferably 6 inches further. The holes should be so placed and the charge of powder so gauged that the shot will do the work expected of it. Permissible explosives should be used, preferably handled by competent short firers, who should blast the holes after the men have left the mine. It would seem the best practice to have the holes placed, drilled, charged, and fired by the one set of skilled men, but this is not ordinarily economically possible. In any case, however, the shot firer should refuse to fire any hole that appears improperly placed or overcharged. As sources of danger apart from misplaced and overcharged holes, the presence of gas and dust must be considered. A place should be examined for gas before the shots are fired, and if found in dangerous amount, it should be removed. Dust, however, is more apt to be a source of danger than gas. It cannot ordinarily be removed, but, if possible, should be thoroughly wetted down or covered with rock dust.

QUES. 10.—The velocity of the air in an upcast shaft 14 feet in diameter is 1,100 feet per minute. How much air is there returning from the mine?

ANS.—The area of the upcast shaft is equal to $.7854 \times d^2 \times .7854 \times 196 = 153.9384$ square feet. The volume of the air-current is therefore, $153.9384 \times 1,100 = 169,332.24$, say, 169,000 cubic feet per minute.

來 來

Trade Notices

New Servus Oxygen Rescue Apparatus.—A new type of mine rescue apparatus is announced by the Servus Rescue Equipment Co. The entire construction is placed on the back, the chest and waist being entirely free from any incumbrance, the two air tubes for the exhale and inhale running over the shoulders. The weight of the 24-cu-ft type is 22 pounds. Three other models are made for one hour and one-half hour work. One is known as Escape apparatus and is designed for one-half hour service for taking into the mines after an explosion or fire to enable any who may be walled in by a body of gas to be brought to the surface.

These apparatuses are operated entirely by "oxodem," which is an oxygen-producing chemical, and from this a supply of oxy-

gen is generated in the apparatus by the same method as is employed to generate acetylene gas from calcium carbide. Sodium hydrate in short sticks is used for absorbing carbon dioxide. The exhaled air passes over the left shoulder, through the first purifier and into a flexible rubber bag, where the oxygen is being generated and which is also used for the breathing bag. Having become reoxygenated, it then passes through the second purifier, which takes up any carbon dioxide which may have escaped the first purifier, and into the cooler, which consists of a series of copper tubes, submerged in cold water, after which it passes through a non-collapsible tube over the right shoulder, back into the lungs, the necessary motive power for circulation being supplied by the lungs, directly controlled by air valves of the mica disk type. The Servus mask encircles mouth, nose, and chin, and is sealed with a pneumatic cushion, supported by a strap to a cap and a second strap around the neck. The breathing bag is covered with a strong mohair and canvas protector and encased in a metal framework, sufficiently sturdy to support the weight of the operator, and owing to this framework it is impossible for him to have all of the air squeezed out, as often happens when wearing those types of apparatus which have the breathing bag in front, when going through narrow spaces or crawling. Severe tests made under various conditions have demonstrated that the oxygen supply is ample for the most arduous labor, and the removal of the CO_2 is complete.

New Wood Pipe Firm.—M. M. Brown, long experienced and well known as a manufacturer of wood pipe, is at the head of a new company which has opened a completely equipped factory and is now turning out pipe at Williamsport, Pa., in the center of the Pennsylvania lumber market, with excellent railroad facilities. The new firm is known as the Standard Wood Pipe Co., with Mr. Brown as president and active manager. The company is in a position to handle both large and small orders.

Applications of Roller Bearings.—A new catalog recently issued by the Hyatt Roller Bearing Co., of Newark, N. J., shows comparative tests of mine-car wheels equipped with Hyatt roller bearings and with solid wheels, also illustrations of bearings after long use, showing very slight wear. These bearings have been applied to mine-car wheels made by many different manufacturers as are shown by illustrations in the catalog, and the catalog should be in the hands of all users of mine-car wheels.

Lunkenheimer Catalog.—The new catalog recently issued by The Lunkenheimer Co., of Cincinnati, Ohio, besides being a complete list of the goods manufactured by the company, is an impressive illustration of the great variety of apparatus, both large and small, that is required by modern steam plants. The book contains over 650 pages, and in it are listed valves of all kinds and sizes for handling steam, water, air, gasoline, or other fluids; also whistles, grease cups, lubricators, oil burners, joints and couplings, oil pumps, and other apparatus for similar use. The catalog is conveniently arranged, and in it can be found full particulars in regard to any goods in this line. As this book contains many new styles and numbers it supersedes all former catalogs issued by the company, who will send it free to those interested, upon request.

The Pneumatic Pump.—A pump especially suited to handling muddy, gritty, or acid waters is made by the Harris Air Pump Co., of Indianapolis, Ind. It consists of two cylinders, side by side, with an automatic switch controlling the admission of air to the cylinders. Water enters one cylinder by gravity, while the water is being expelled from the other by air under pressure. When this cylinder is nearly empty the automatic switch releases the air from the empty cylinder and applies it to the other, which has filled with water in the meantime. The cylinders being filled by gravity the action is automatic, and the only connections required are the compressed-air pipe and the discharge pipe. No moving parts come in contact with the water, and its automatic action makes it suitable for operation at a distance from the power house.

ORE MINING AND METALLURGY

Gold Dredging Up to Date

History of the Rise of Dredging in America—Costs and Conditions in Various Regions

By Arthur Lakes

Of the various methods employed for winning precious metals that of dredging for gold is the least generally known, although in the present day it is one of the safest and most lucrative forms of gold mining.

This lack of familiarity is due to the extreme youth of the industry which has made such rapid strides during the past 10 years. Whilst gold dredging may have dated back as much as 20 years, it is only within the present decade that successful dredging has been carried on on a large scale, and that dredges

Works of San Francisco, and it operated for several years at the lower end of the Oroville district. This first dredge was far from being a complete success, but it showed the world what could be done. It required many years of evolution for the gold-dredging industry to reach its present stage of practical success. The old-time miners had long had the idea of scooping up the gravels inaccessible to hydraulics; and not long after Marshall's discovery of gold in California, a "gold-digging machine" was shipped around the Horn from New York to San Francisco and installed in 1849, soon to become a useless wreck and sink to the bottom of the Sacramento River. Several devices were subsequently tried; but with the exception of the operation of the double-lift bucket-elevator dredges on Grasshopper Creek, Mont., in 1894, all proved failures. In 1897 the first dredge of the single-lift, bucket elevator type was floated in California on the Yuba River. This dredge was unfortunately wrecked. Various

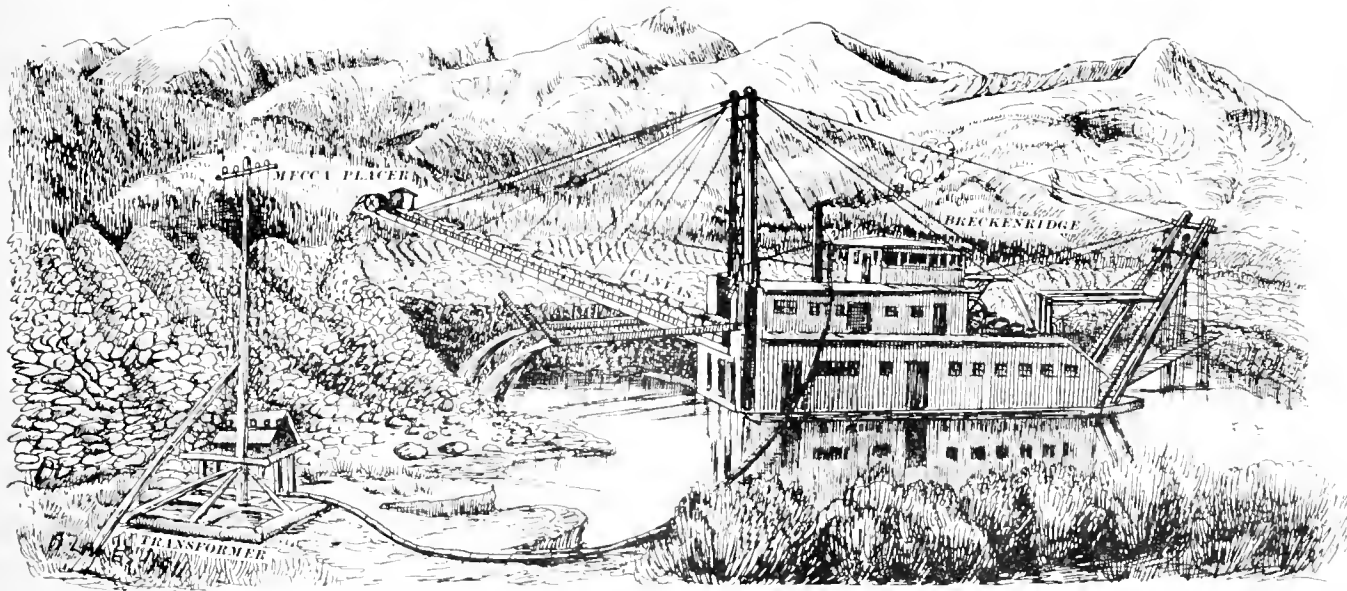

FIG. 1. DOUBLE-LIFT DREDGE, REMODELED, WORKING ON FRENCH CREEK, CANVAS ON STACKER FOR WINTER USE

have been brought to the high standard such as now characterize those in California and other regions of the world.

The first practical gold dredge in America was built in 1898 in California, and marked the beginning of a new era in gold mining in this country.

"The success of the industry and the rapid improvements in the construction of dredges have made the California dredge the model after which other countries pattern." So says Mr. Lewis Aubury, late State Mineralogist, in his introduction to the excellent bulletin on "Gold Dredging in California," written by Messrs. Winston and Janin. "Since the inception of this industry the production of this state has advanced upwards of three and a half million dollars above the average output of two years ago."

The modern dredge handles from 60,000 to 300,000 cubic yards of gold-bearing gravel monthly at a cost of from 6 to 2¼ cents per cubic yard.

As there are between 30 and 50 of these great dredges constantly at work, and increasing in number, they will give some idea of the magnitude of the industry in this state alone.

The California enterprise originated with the successful operations of Messrs. Hammon and Couch. These gentlemen contracted for the first dredge of 1898 with the Risdon Iron

machines, such as the submarine boat, the pneumatic caisson, the hydraulic or centrifugal pump, suction dredge, the clam-shell, orange-peel, and vacuum dredge, all proved failures.

The steam shovel was used in America for excavating long before the gold dredges. This and the single-bucket, or spoon, dredge, as evolved in the early sixties in New Zealand, were the forerunners of the present placer mining "dipper dredge" which in several instances has proved successful. These dredges were operated by hand and later by current wheels, and in 1870 by steam. The first experiments in 1867 were at Otago, New Zealand, with bucket-elevator dredges. Many of these early machines, like some tried later in various regions, were of too light a construction to cope with the heavy gravels they were compelled to handle. In time the double-lift type was abandoned for the single-lift, and open-connected buckets changed for the close-connected now in use. In 1901 the model dredge was constructed and electrically driven. The first dredges began with buckets of 3¾ cubic feet capacity, later increased to 5 cubic feet, still later to 7½, and in 1905 to 8½ and 9 feet. In 1905 13½-cubic-foot-dredges were put in commission along the American River in the Folsom district; 15-cubic-foot buckets are contemplated, and one is at work in Montana. A depth of 50 to 75 feet to

bed rock on the Yuba River required new features in dredge construction. Upwards of 100 dredges were constructed between 1897 and 1910. Between 1898 and 1908 the dredges produced over \$25,000,000 worth of placer gold in California. In 1903 the gold production from dredges exceeded that of both the hydraulic and drift mines combined; by 1910 the output from dredges exceeded \$7,000,000.

Modern dredges are equipped with buckets from 7½ to 13½ cubic feet capacity. Whilst early dredges had a capacity of from 25,000 to 45,000 cubic yards of gravel per month, the large modern dredges handle an average of from 160,000 to 250,000 cubic yards. New fields are constantly opening up both in California and elsewhere.

The largest dredging fields in California are on three of the large rivers on the western slope of the Sierra Nevadas. The area also includes a great portion of the ancient river channels crossed at right angles by those of the present streams. The

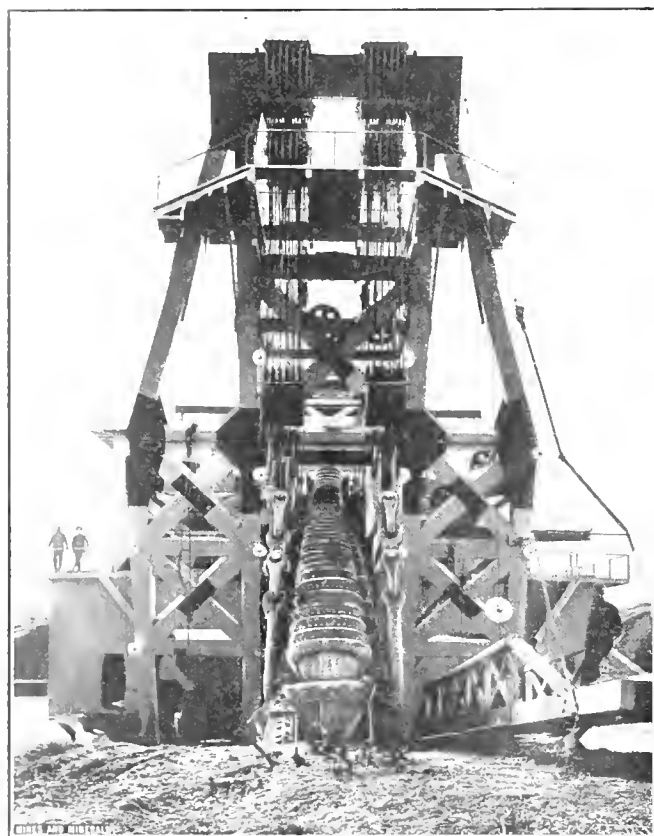

FIG. 2. FRONT VIEW OF DREDGE

placer deposits of the present streams, are river bars, banks, benches, or flood plains. The gold is derived from the small quartz veins in the slates, and quartz lodes in the bed-rock series, also from the ancient gold-bearing channels eroded by the modern streams. At Oroville is the ancient bed and debouchure of a great river from the north; at Smartville is one, the counterpart of the Yuba. In Placer County are old river channels, predecessors of the American River. The old river channels were filled with gravel and white quartz capped with lava. The present river is composed of boulders of silicious and volcanic rocks and quartz, and is underlain by shales, coarse in the high mountains. It was formed from the sulphide ores, from which it was freed by the action of the water. The bulk of the gold is found in or near the surface of the gravel, and is associated with black sand.

The cost of a California-type dredge varies, and is generally from \$50,000 to \$200,000. The following figures give a

general idea of the cost of different size dredges. The size of a dredge is estimated by the capacity of its buckets:

One with 3 and 3½ cubic feet capacity buckets, \$50,000 to \$60,000; 5 and 5½ feet, \$50,000 to \$90,000; 7 and 7½ feet, \$80,000 to \$120,000; 8 and 8½ feet, \$170,000 to \$175,000; 9 and 9½ feet, \$130,000 to \$200,000; 12 and 13½ feet, \$175,000 to \$225,000.

Some fairly successful "dipper dredges" have been built for \$25,000. Such are best adapted for shallow ground, and where the ground is rough, with boulders and stumps, or contains much clay.

Small and light dredges did well enough in early days on shallow and fine gravels, but where the gravel became deep, cemented, or carrying large boulders, the large California type of dredge, equipped with heavy machinery, close-connected buckets, spuds, and belt tailing conveyer, proved its superiority.

GOLD DREDGING IN VARIOUS REGIONS

To endeavor to give even an approximate account of the vast dredging operations that have been going on successfully in California, the world's model dredging ground, or school of dredging, as Curle calls it, during the past ten years, would far exceed the limits of this article, so we shall pass on to a brief sketch of what is being and has been accomplished in other regions and countries. In the United States dredging is being carried on in California, in North Carolina, Colorado, Montana, Idaho, Alaska, and some dredging is going on in the Philippines.

In foreign countries gold dredging has been carried on in Canada, in the Klondike and British Columbia; in Sonora and Sinaloa, Mexico; in Central America, in Honduras; South America, Colombia, the Guianas, Brazil, Argentine Republic, Chile, Peru, Bolivia, and Ecuador; in Australasia, Victoria, New Zealand, New South Wales; in India, in Burmah; in Africa, prospecting on West Coast; in Europe, in Siberia and the Urals and Servia.

Dredging in Montana.—In Montana, dredging was begun as early as 1894. The largest and most modern dredges in the world are operating at Ruby. The principal field is 5,200 feet above sea level in Ruby Valley, Madison County, where the celebrated Alder gulch issues from the mountains. Harvard University is interested and will reap in time between one and two million dollars from it. Alder gulch, in 13 miles of its course, within a width of 300 feet and depth of 20 feet, produced by placer mining from seventy-five to a hundred and fifty million dollars by the crude methods of rocking and hand sluices, open cuts, hand shoveling, ground sluicing of overburden where material was shallow, or by drifting and hoisting to the sluices where deep.

Gravel ranges from 30 to 60 feet deep, is coarse and compact with clay and large boulders. Bed rock is a tenacious clay from volcanic tufa and ash, like Oroville. It is so sticky when excavated by buckets that it has to be dug out of them; hence bed rock is only skimmed slightly; both true and false bed rock occur. Gold is 840 to 860 fine. Content of gravels is about 25 cents per cubic yard. In 1906 a 15-cubic-foot open-connected bucket elevator dredge was put in. The hull of this abnormally large dredge was 130 feet long, 48 feet wide, 7½ feet deep; 400,000 feet of lumber were used. Its monthly record was 90,000 cubic yards, or 3,300 cubic yards daily, at a cost of 6½ cents per cubic yard. The 15-cubic-foot buckets weighed each 2,800 pounds, with 5½-inch pins; manganese-steel bushings are used with locomotive-tire steel pins. Close-connected buckets are to succeed the open-connected ones. The Ruby dredges were the first to run throughout the winter with thermometer 25 to 35° below zero. The steam dredges warm their ponds with water of condensation, also using live steam. Ice is chopped from sides, ladders, and chutes. Dredges are manipulated to keep parts likely to freeze well exposed to the sun. Ground to be dredged is kept flooded and so does not freeze, whilst the dredge pond is kept open by continuous operation. Amalgam is softer and takes more mercury to do the same amount of work during cold

weather. During 1907 the temperature was at zero, or even as low as 30 degrees below it. The pond was kept open by movement. Ice accumulated on the hull, causing it to sink considerably, also on the ladder, obscuring the rollers so buckets slid on ice. Sheaves froze solid. Ice accumulated in hopper. Out-board pump suction froze if dredge temporarily stopped. Inside pipes froze and burst. The dredge operated 72 per cent. of the time during January. The dredge has boiler and steam pipes for men, hot water for clean-ups, heat for false-bottomed sluices. Amount dredged in January, 1907, was 81,000 cubic yards in 539 hours.

Dredging at Breckenridge, Colo.—The elevation of this field is 9,500 feet above sea level. The deep, or dredgable, gravels occupy the flood plains of the Blue River and its tributaries, Swan and French creeks. The gravel depth varies from 25 feet as a minimum to 76 feet as a maximum, with an average of 40 feet. The floor is uneven, consisting of alternations of a partly decomposed porphyry and a black shale; large boulders are common and sometimes are over a yard in diameter. Pay streaks occur in incontinuous channels having no relation to those of the present rivers. Gold is coarse, 17 to 18 dollars per ounce. Black sand is locally plentiful. The high or "bench" gravels rise above the river plains and, lying against the flanks of the mountains, were worked profitably by the early comers; the deep gravels are now the field of the dredges. Early dredges built failed from not being strong enough to grapple with the deep and heavy gravels. Numerous elevator and other devices also failed till modern large and up-to-date California dredges were introduced which are working successfully. Three dredges are at present in active operation. The Reliance dredge by using similar appliances and methods as those in Montana is able to work through the winter or throughout the year. The dredges are worked by electricity. The Colorado Gold Dredging Co. are reported to have sand worth 12 to 14 cents per yard and to handle it at a cost of 5 cents. Gold saving has been estimated to reach 80 per cent.

Dredging in Alaska and British Columbia.—Dredging is going on at Nome, on the Yukon, Seward Peninsula, and Forty-Mile District.

In 1909, eleven dredges were working in the Seward Peninsula. Some operated from the middle of June to middle of October, the full dredging season of that district. In some places it was necessary for a time to dig 6 feet into a hard limestone bed rock to extract the gold. Steam power is used; coal \$20 per ton, operating costs, 11 cents per cubic yard, with a total, including winter care, repairs, etc., of 18 cents per cubic yard. Some dredges use 4.6 tons of coal daily.

A little "toy dredge," called the Sievertson dredge, on Solomon River, worked by gasoline engines and equipped with 1-cubic-foot buckets, open connected, and costing \$6,000, is said to have made a profit of \$15,000 in one season.

There is a field in the Seward Peninsula for dredges with 3- to 5-cubic-foot buckets. Stream beds are shallow, 10 to 25 feet deep, bed rock is schist or limestone, gravels loose and free from large boulders and clay.

The record of the Yukon dredges is interesting, as the ground had to be thawed by steam. The Yukon Company operated 7 dredges, dredging season, 132 days. During the season the dredges handled 2,381,800 cubic yards, producing \$1,363,722 worth of gold. Value per cubic yard was abnormal, viz., 57.24 cents, and cost 31.94 cents per cubic yard, including thawing charges amounting to 15.45 cents, preliminary stripping operations, and depreciation at rate of \$2,000 per month per dredge.

To contend with the severity of winter, the Bear Creek dredge used steam pipes extending on both sides of the entire length of the enclosed stacker ladder, with steam coils under the lower belt rollers, under the sluice tables, and in the house over the main drive and other points to be kept free from frost. The dredge was operated in a temperature of 20 degrees below zero without the slightest difficulty. Applying hot water to the fair-lead sheaves through which the shore lines were operated pre-

vented any difficulty from that quarter. Climatic conditions with frozen ground, according to Purington, eliminate a large proportion of Alaska, despite the fact that it may be gold bearing.

One of the heaviest items of expense in Alaska placer mining is transportation. Price for labor is \$5 to \$6 per day and board. Coal costs \$15 to \$18 a ton at Nome. To this is the cost of transportation to the scene of mining operations. High costs of dredging, such as 80 cents, in the Klondike, is due largely to the cost of using steam points in front of the dredge to thaw the frozen ground. At Atlin, B. C., the gravel is 20 cents per cubic yard; the depth of gravel, 90 feet, together with a heavy overburden are obstacles adding to cost of production.

Dredging in the Philippines, New Zealand, Russia, and Siberia.—The Paracale district in the Philippines is the principal mining area. The mines and streams were worked intermittently before the days of the Spanish conquest and the hills are honey-combed with ancient workings. The rocks are metamorphic and

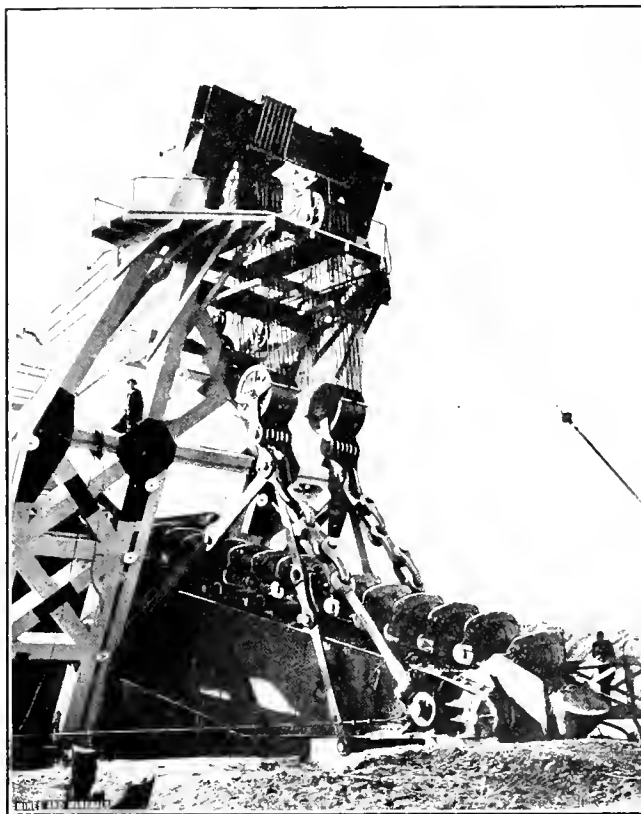

FIG. 3. SIDE VIEW OF DREDGE BUCKETS

igneous with quartz veins. Large river plains exist favorable for dredging. These are being drilled, whilst several dredges show good returns. Placer grounds consist of layers of barren clay mixed with vegetable matter, overlying beds of coral, and a rich gray clay, with rich gravels below containing quartz pebbles showing free gold. The gold dredged is crystalline and has not traveled far. Bed rock is decomposed schist. Between May and December, 1908, 2,814.1 ounces were obtained valued at \$50,653.80. Much fine material and clay passing through the screens are obstacles. The Paracale River is an arm of the sea. Depth to bed rock is 30 feet.

In New Zealand there is a decline in production as well as in the number of dredges. The days of the small light dredge are past and will be succeeded by large up-to-date dredges handling low-grade material.

Gold dredges are of recent introduction in Russia, dating back 8 years. Tailings of old workings would make good dredging fields. About 50 dredges are at work in Siberia.

Gravels are about 15 to 30 cents per cubic yard. The placers of Siberia are scattered over an area of 5,000,000 square miles and offer every variety of depth, bed rock, etc.

Only in the extreme north is permanently frozen ground met with. Sticky clay on top of the river gravel is a great hindrance, rolling into balls, "stealing" the gold, and preventing its saving.

Gold is sometimes very fine, yet heavy; again there is so much silver in it that it is light and hard to save. Generally the gold amalgamates easily. Wood is used for fuel.

Mexico Dry Placers.—Several of these occur in the State of Sonora, but working them so far has proved a failure.

Gold Dredging in Colombia and the Guianas, Peru and Bolivia.—All the larger rivers are auriferous and there are several attractive dredgable fields with high gold content. The malarious climate is one of the greatest drawbacks.

In French Guiana some dredges are at work on the rivers. There is no difficulty in removing the driftwood buried in the alluvions more than large boulders. Clay is washed with jets of water or separated by picks. Natives can be taught to handle a dredge. Gold placers are rich. The new dredges are to have a double revolving screen 33 feet long disintegrating the clay. Monitors are also used for the same purpose.

dredges in the Malay peninsula have singly won as much as 375 ounces gold in a week and in 2 months, 1,600 ounces. In some areas stream tin is being dredged as well as gold.

KINDS OF LANDS AVAILABLE FOR DREDGING

The kinds of lands, or regions adapted to gold dredging is the first consideration. Areas suitable for dredging are those where from one natural cause or another there has been a wide flowage and the distribution of gold-bearing gravels. These so-called "gravels" may include pebbles from a fraction of an inch to boulders several feet in diameter. Such material has commonly been brought down by glaciers, streams, or other bodies of rapidly moving water, from gold-bearing rocks in the neighborhood, sometimes from a considerable distance, and distributed over the more open lands and valleys. Flood plains reduced nearly to base level traversed by meandering streams are proper dredging grounds.

The modern river may have little relation to rich deposits which have been distributed at various points in so-called "courses" or channels by older streams or bodies of water traversing in various directions the country occupied by the present river flood plain.

It is not necessary that there should be important gold mines

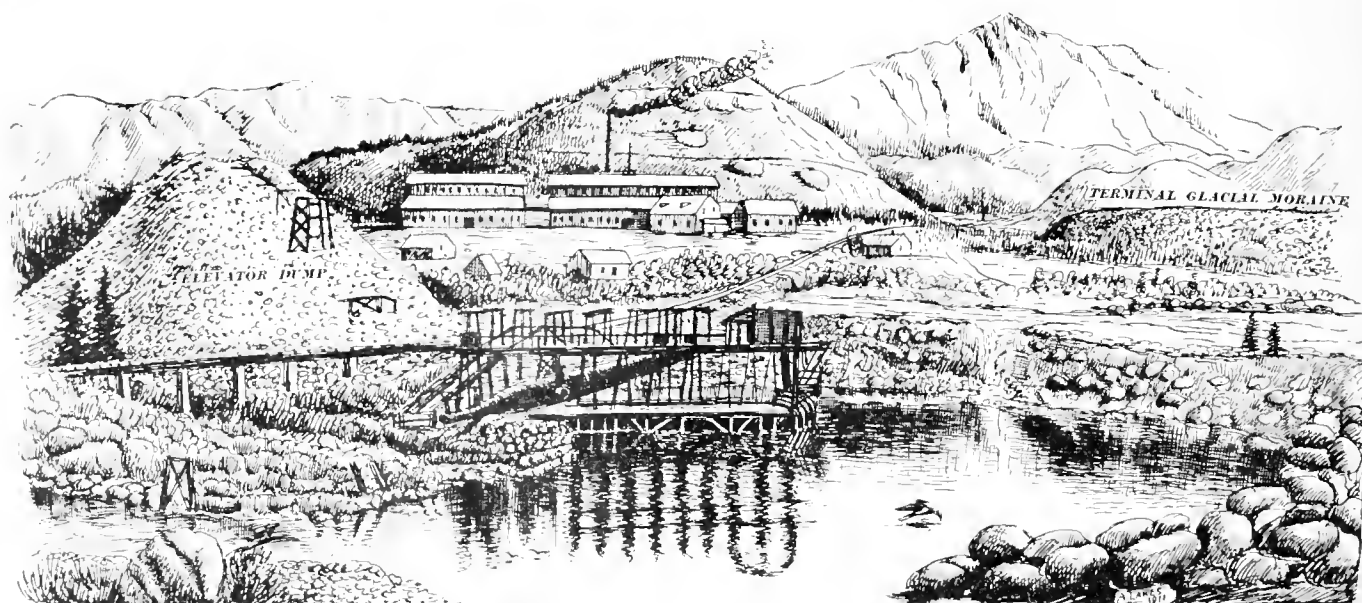

OLD DREDGE POND, BRECKENRIDGE, COLO., REMAINS OF HYDRAULIC ELEVATOR IN FOREGROUND. LARGE BOULDERS, 6 FEET IN DIAMETER, SHOW WHY ENTERPRISE FAILED

A few dredges have operated in Peru and Bolivia. True bed rock in some cases is not met with, being too deep; but concentration of gold occurs on false bottoms of rusty conglomerates. In Peru are several available river flats; transportation of dredge machinery is at present the main obstacle.

Dredging in Terra del Fuego.—The alluvial gold appears to have been of marine deposit derived from a detritus of schist, diorite, syenite, and clay slates; few gold-bearing veins have been found. These alluvions are in beds of creeks or on sea beaches as at Nome, Alaska. Ground is claimed to average 15 to 25 to 50 cents per cubic yard. Beds are 10 to 30 feet deep. Prospecting is by boats, as the land is cut up by wide water channels and the rest is boggy. A wild-cat boom took possession of the country at one time and dredges were located without prospecting. As many as 23 of these wild-cat dredging companies were inaugurated and all failed.

The dredges were constructed in Holland, and operated by steam with pumps and fans. Turf or peat was tried as a substitute. The companies were of Argentine or Chilean origin. In Brazil are several dredging companies at work on the rivers. At Diamantina they are dredging for diamonds and gold. Some

or large gold veins in the vicinity to yield values to such gravels. It is a curious fact that the majority of the great placer and gold-dredging fields of the world have no prominent working gold mines in their midst. The gold found is for the most part derived from minute gold-bearing veinlets and irregular deposits and disseminations in the surrounding country rocks, such as slates and schists, and particularly in those of an igneous origin, such as granites and porphyries.

It is common for extensive hydraulic operations located on "bench" or high banks of gold-bearing gravel to have preceded the gold dredging. These hydraulic placer operations were of necessity confined to the high banks fringing the river, plain, or meadow containing the deep gravels. The latter, being inaccessible to the hydraulic giant and other placer-mining machinery, were left as the proper domain of the modern gold dredge with its powerful machines and deep-digging buckets.

We may sometimes enter regions notorious for their past records in placer mining, where the early comers with their simple devices reaped a rich harvest until their methods were exhausted or they worked up to the limit of their high line water supply, and find the area of equally rich deep-lying gravels

untouched and available for the dredge. The origin of the "gravels" and gold in these deep dredgable areas is very similar to that of the high bench or hydraulic placer "gravels."

In some of the high dredging regions, like those of Breckenridge, Colo., glaciers have been the prime excavators and transporters of the gold-bearing rock to form both placer and deep gravels. Subsequent streams have comminuted and distributed this material. Hence, in the high mountains, the deep gravels occupying the bottoms of cañons or upper portions of the river plain commonly abound in large boulders, which farther down stream or away from direct glacial influences diminish in size.

In a region near sea level, like Oroville, Cal., where glaciers did not prevail, or where gravels have been brought from a considerable distance, pebbles are apt to be small, the deposits comparatively shallow, and the gold widely disseminated. The history of this noted dredging field is typical and instructive. According to C. W. Purington, "North and east of Oroville erosion of a vast extent of mining country, whose rocks are penetrated by gold-bearing veins, has contributed to the mass of detritus now occupying the bed of Feather River. The wearing down of mountains caused the formation of a valley of extraordinary width but of no great depth. The stream, choked by material, deposited its load irregularly, filling its wide valley with sand and gravel containing gold. Old geological valleys should be sought for dredging, because the size of boulders is decreased, gravel is uniform, pebbles common, and even distribution of gold is a consequence of old, wide valleys. Finely divided gold, however, requires skill in recovery. Floods and freshets cause irregular deposition of gold in patches." Gold at a depth of over 100 feet is irrecoverable by dredging.

Oroville was originally a noted placer camp; long before it became a dredging field the gravels were worked over and over again by both white men and Chinamen. These so-called "worked-out" portions now yield the high returns to the dredges. Gravel averages 40 feet in depth and lies on a bed rock of soft volcanic ash, with values of 15 to 25 cents per cubic yard. Cost of dredging, near town, is only 3 cents per cubic yard; plenty of water is here for electricity or other uses. It is an ideal gold-dredging ground.

The Yuba River, another successful field, was previously hydraulicked for years and 300,000,000 cubic yards of the hydraulicked material is deposited on the lower river bed. The old river bed is covered by 30 feet of sand from the same source, and digging depths are from 50 to 72 feet, practically the limit of modern dredging. Water level is only a few feet below the surface.

Dredging along the American River at Folsom is on successive bars and benches formed by old courses of the river; 13-cubic-foot capacity buckets are used. Conditions at Breckenridge, Colo., are somewhat similar to the latter, with very large boulders and fairly deep gravels.

"Oroville," says Curle, "is the school of dredging and is ahead of New Zealand, that formerly held the palm." Ten years ago there were no dredges in California; now over 50 are in operation. In selecting lands suitable for dredging, the danger from freshets and floods is in some regions a consideration. Several California dredges have been wrecked in this way.

來 來

Ore Mining Notes

Cobalt's Past and Future.—Prof. G. R. Mickle, Provincial Mine Assessor, in an address to the Cobalt Branch of the Canadian Mining Institute, stated that Cobalt's producing veins have years of life ahead of them, at the present rate of production, and in addition there is the possibility of production from undiscovered veins. Up to July of 1911 there were 111 known producing veins, and of these 86 were in the Huronian; while 12 of the veins were in the diabase, and the remaining 13 in the Keewatin.

In 1907 there were 53 known producing veins in the Huronian, 7 in the diabase, and 6 in the Keewatin.

Other facts presented were that nine-tenths of the veins in the Huronian do not carry silver into the Keewatin, and those that do are negligible. Ninety-seven per cent. of the silver produced in the camp is produced at a profit.

By means of well-known formulas, the accuracy of which is certain, Professor Mickle told the members of the Institute how he had arrived at his conclusions.

Fifty-six per cent. of the silver in the known producing veins has been extracted, which leaves 44 per cent. to come. The production from these veins to date has been 115.8 million ounces, so that the total production will be 206.4 million ounces. From this it will be seen that 90.6 million ounces are yet to be produced.

Added to this future production of 90.6 million ounces there will be a probable production of 35 million ounces from undiscovered veins, and there are approximately 8 million ounces on the dumps.

Therefore, the total production is computed as 206.4 million ounces, plus 35 million ounces, plus 8 million ounces. That he might not overestimate, the speaker placed the total production at 247 million ounces, and it is conceded by the members of the Institute who heard his explanation that if he erred, it was by underestimating.

To the end of 1911 the total production of silver in the Cobalt camp was valued at \$64,918,752. Taking Professor Mickle's figures that there are yet to be produced, approximately, 132 million ounces, and giving the average silver value as 55 cents an ounce, the value of the silver yet to be shipped from the camp will be \$72,600,000, which would make the total value of silver produced from the known and undiscovered veins \$139,518,752.

Nevada Consolidated Copper Co.—Nevada Consolidated earned net in the first quarter of the current calendar year \$1,233,768, which compares with \$1,012,729 in the corresponding quarter of last year and with an average quarterly net of \$867,250 in the 15 months ended December 31, 1911, embracing the period from the close of the preceding fiscal year. The net earnings were \$483,995 in excess of dividend needs, comparing with an excess of \$263,349 in the first quarter of 1911 and \$80,562 above the needs in the same period of 1910. There was charged off for depreciation to the Steptoe plant \$145,762, comparing with \$136,883 in 1911's first quarter and \$130,443 in 1910. There was charged off also \$125,754 for ore extinguishment, for which no deductions were made in the first quarters of the preceding two years, but there was a surplus of \$212,479, which compares with a surplus of \$126,466 in the first quarter of last year, and a deficit of \$40,881 in the first quarter of 1910. Undivided profits March 31, 1912, were \$2,041,261 and surplus \$9,070,261.

Copper production in the first three months of the year is reported as 17,578,450 pounds, which compares with 15,893,743 pounds in the first quarter of last year and 13,528,467 pounds in the same period of 1910. In the 15 months ended December 31, 1911, the average quarterly production was 15,708,250 pounds.

The production by months was: January, 6,309,228 pounds; February, 4,888,790 pounds; March, 6,380,432 pounds; the low production in February being due to the dry season and curtailment of water available at the Steptoe concentrator. To protect against a recurrence of these conditions an appropriation has been made for additional reservoirs at the concentrator.

During the quarter 728,592 tons of ore were milled, averaging 1.85 per cent. copper. Of this tonnage the Veteran mine supplied 75,547 tons, from underground work. The ore extinguishment item heretofore has appeared only at the end of the year, but as some misunderstanding resulted from this method the ore extinguishment will be deducted quarterly.

The report confirms the contract entered into for the treatment of the sulphide ores of the Giroux and for the smelting of the concentrates, the contract running for 5 years, but may be canceled on 1 year's notice.

Atlantic City Mining District, Wyo.

Description of the Mines in a Region That, While Long Known, Is Only Partly Developed

By O. R. Taggart, E. M., Denver, Colo.

The South Pass, or Atlantic City, mining district is about 35 miles south of Lander, Wyo., the nearest railroad town. Owing to this distance from a railroad the district has been rather slow in development. Fuel is far from abundant and freighting by teams is a costly operation. At the present time, there is one mine in full operation; two others are doing development work; and several expect to start this spring.

This district was discovered about 1867, and some work has been going on ever since. Most of the claims are, as yet, only in the prospect stage. The deepest shaft is but 385 feet.

The veins are in two systems; one striking almost due east, the other in a northwesterly direction. The gangue is quartz. The whole district is very much faulted and contorted, so that it is difficult for one to trace the veins. The values are all found as free gold in the quartz.

The Duncan mine, owned and operated by the Beck Mining Co., has been for the past 2 years, and at present is, the only mine in full operation in this district.

The quartz vein, which is from 2 to 5 feet wide with a dip of 75 degrees north, carries free gold which varies from \$7 to \$50 per ton. Some assays have gone as high as \$100 per ton in gold.

The inclined shaft follows the veins down to the third level, where the dip of the vein changes; and from this point to the fourth level the shaft is in the country rock, a very hard diabase. Recently, in cross-cutting from the shaft at the fourth level, quartz was found that assays \$35 per ton and is thought to be a continuation of the vein. Another cross-cut is being driven on the third level, to intersect a large quartz vein, that outcrops about 600 feet west of the main shaft.

The ore is trammed to the shaft in buckets placed on small trucks. Hoisting is done by means of a 500-pound bucket that runs on wooden skids and dumps into an ore car at the surface. In this way about 60 buckets can be hoisted in an 8-hour shift.

Gasoline is used to develop power for both the mine and the mill. In the shaft house the hoist is run by a 15-horsepower



FIG. 1. MILL AT DUNCAN MINE, WYOMING

drill compressor is operated by a 32-horsepower gasoline engine. The mine pump, alone, uses steam, and the boiler in the shaft house, using cordwood for fuel.

The new mill, shown in Fig. 1, built last summer, has a capacity of 100 tons per day, or 10, 1911. It contains four 1,000-pound stamps, 100 stamps per minute, with an 8-inch Frue vanner, 10 amalgamating plates, 10 amalgamating plates,

36 inches wide; four 5-foot plates; two amalgamators; and one concentrator.

During the month of September, the mine supplied enough water to run the mill for 24 hours each day; but in November this supply gradually decreased until it became necessary to install an 8-foot Callow tank to conserve the water. The overflow from the Callow tank is pumped directly to the batteries and used repeatedly.

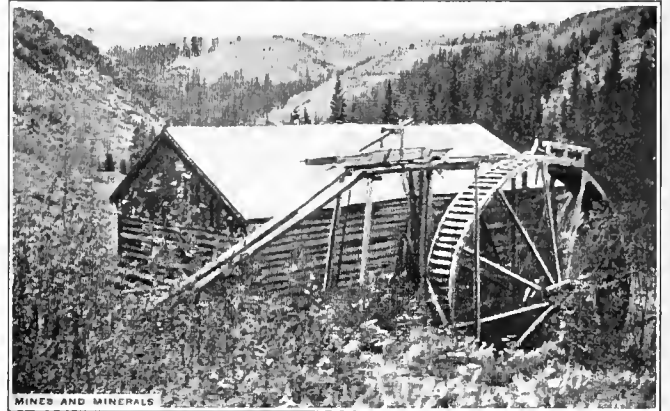

FIG. 2. OLD TEN-STAMP MILL, SOUTH PASS DISTRICT, DRIVEN BY 30-FOOT OVERSHOT WHEEL

The ore is trammed into the mill and dumped on to a 6' x 8' grizzly having 1½-inch spaces. The oversize falls to the crusher floor, where it is shoveled into a 7" x 12" Blake type crusher. The crushed ore and the undersize fall together into the ore bin that has a capacity of 150 tons. From this bin, it is fed through four automatic ore feeders into the stamp mortars, where it is crushed to 32 mesh. It then passes over the amalgamating plates, through the amalgamators, and into the dewatering tank.

The dewatered pulp is discharged into a pond below the mill, where it is being saved for future treatment. The mill extraction averages a little over 60 per cent.; on some of the ore it goes as high as 72 per cent. A large part of the ore thus far milled has been taken from the mine dump, and there is still enough of this material left to supply the mill for a considerable time.

The mill is operated by one millman on each shift, with an extra man to tram and crush the ore on the day shift.

A 25-horsepower gasoline engine drives the stamps and ore crusher. A 10-horsepower gasoline engine drives the 7-kilowatt generator that supplies the light in the mine and surface plant, and also operates the mill pump through a 2-horsepower motor.

The Mary Ellen mine, about one-quarter of a mile east of the Duncan, has a quartz vein, varying from 5 inches to 3 feet in width. The vein is in diorite and dips 33 degrees northwest. This property is developed by two inclined shafts, 230 feet and 150 feet deep. The ore averages \$7 to \$10 per ton in gold, but to the present time only the very highest grade ore has been mined.

The gold is recovered by the aid of a 5-foot Huntington mill and amalgamating plates. A short time ago the property was secured by Denver people, who intend to remodel the mill. These owners expect to recover about 60 per cent. of the gold in the ore, and have started underground development work.

The Carisa mine, at South Pass, owned by the Federal Gold Mining Co., is the largest mine in the district. The shaft is 385 feet deep and there are 1,200 feet of drifts and cross-cuts.

The mill contains ten 1,000-pound stamps, amalgamating plates, and a Frue vanner. This company contemplates enlarging the mill to 30 stamps in the near future.

The Big Chief mine, one-half mile west of Atlantic City, has been doing development work this winter. The owners have made arrangements with the Beck Mining Co. to have about 200

tons of the Big Chief ore run through the mill at the Duncan mine.

A complete list of the mines in this district and their output can be obtained from Bulletin No. 2, Wyoming Geological Survey.

The greatest drawback to the development of the South Pass, or Atlantic City, district is the high cost of power. Freighting by teams from Lander costs \$1.00 per hundredweight, so the use of coal is out of the question. Wood for fuel costs \$4.85 per cord delivered at the mines. Gasoline costs 26 cents per gallon, delivered at the mines.

The Beck Mining Co. expects to build a hydroelectric power plant, this spring, on Little Popo Agie River. The power site is about 8 miles from the Duncan mine, and the head is 760 feet with a flow of 21 to 35 second-feet during the winter.

If this power plant is erected it will mean a great boost to the district, since many of the mines now shut down will be able to resume operations. In addition to the gold mines in Fremont County, Wyo., there are Indians, hot springs, oil wells, gypsum, coal, copper, iron ore, and building stones.

The copper has never been developed, although C. E. Jamison, State Geologist, has this to say about it: "Copper is known to exist in several points in the Wind River Mountains. At the present time the Wyoming Copper Mining Co. is developing a body of copper ore 1 mile west of South Pass City. The deposit, 40 feet wide, is being developed by a shaft 245 feet deep and by drifts and cross-cuts. The ore is reported to contain from 4 to 16 per cent. copper, from \$2 to \$10 in gold, and from 1½ to 40 ounces silver per ton. The gangue material is quartz, the walls of the vein being schist. The Albertson prospect, 3 miles northeast of Atlantic City, has a quantity of high-grade copper rock on the dump. About 10 miles north of South Pass there is a large outcrop of rock containing copper. Although this is owned by residents of Lander, no development has been attempted."

High-grade iron ore is reported to exist in the Wind River Mountains north of Atlantic City. Samples of this ore inspected by the writer were too low grade to be of commercial value.

來 來

Reply Postage on Foreign Mail

A bulletin issued by the Philadelphia Commercial Museum states that there is a vast difference between the American and foreign practice in the matter of sending prepaid postage for replies when initiating correspondence or when asking for information. In the United States there is no well-defined rule in the matter: a few firms inclose return postage, but it is far more usual not to do so. The omission causes no comment because of its generality. Abroad, however, there is a very definite well-understood and generally followed rule that in initiating correspondence and in seeking information, postage for the reply must accompany the communication. A few firms abroad reply to communications of this nature, courteously paying the postage themselves; but such firms are the exception. A large number will throw the communication unaccompanied by reply postage into the waste basket, or perhaps keep it as a novelty, as an illustration of the carelessness or ignorance of their correspondent. In many cases it is considered an evil only slightly less aggravating than short-paid postage itself.

Until the inauguration of the reply coupon there was some excuse for failure to comply with the foreign practice in inclosing reply postage. United States stamps cannot be used and are practically worthless to the foreign business man. But with the reply coupon now obtainable there is no good reason for failing to comply with the practice to which the foreign correspondent is accustomed. These reply coupons, of a denomination of 6 cents each, are issued for the purpose of sending to correspondents in 34 countries and their colonies. They may be purchased at any post office in this country and in any numbers desired. Inclosed in the letter, they may be exchanged by the foreign correspondent, at any post office

in any of the countries adhering to the agreement, for a postage stamp equal in value to the 5-cent postage stamp. By this arrangement the firm in this country can furnish a foreign correspondent with a postage stamp with which to prepay postage on the reply letter. While knowledge of the reply coupon is just as general abroad as in this country, there are times when it might be advisable to inform the correspondent that the coupon inclosed is not itself good for postage, but that it must be exchanged at the local post office for stamp.

來 來

Canvas Table

By B. W. E.

The canvas table shown in the illustration is 16 feet long and 12 inches wide. It is built of 2-inch plank and is thoroughly cross-braced underneath to prevent warping. It is pivoted at the center, as shown, so that the grade may be changed from ¼ inch to 1½ inches to the foot. The canvas is stretched across the grain and it is found to hold the fine ore particles more firmly when stretched this way.

There is a distributing box at the head of the table and the finely ground ore is fed into this from a tub by hand. There is

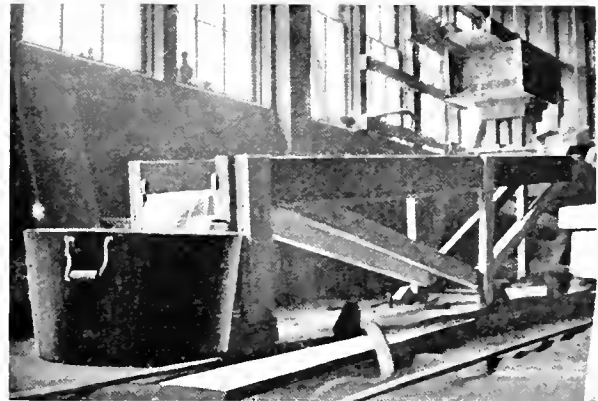

CANVAS TABLE

also a clear-water tank from which a stream of clear water is allowed to flow, which serves to dilute the pulp and to wash the concentrates.

When the operation is complete the tailing tub is removed and the concentrate washed into a clean tub by means of a hose.

The dimensions here given are arbitrary, as any length and width may be used to suit conditions peculiar to the ore under treatment.

來 來

Conditions in the Katanga

A recent U. S. Consular Report states that the Katanga is the name given to the southernmost district of the oriental provinces of the Kongo. It lies east of Angola, north and west of Rhodesia, and west of German East Africa. The district is in general a high, rough plateau, 3,000 to 4,000 feet above sea level, the watershed of south-central Africa. The climate is by far the best found in the Kongo and renders the district inhabitable for white people. Sleeping sickness exists, but otherwise it is comparatively healthful. The Katanga is rich in minerals. Beds of copper covering a region 200 miles long by 30 to 60 miles wide have been discovered, which, according to experts, are the richest in the world. Much of it can be worked by the open-pit method. Assays so far indicate that the average of pure copper is about 13 per cent. Iron and tin have also been found in quantities, and gold, mercury, and manganese have been discovered. Diamonds and precious stones have also been found and the state has temporarily forbidden prospecting for them in large areas. The completion of the Cape-to-Cairo Railroad to Elizabethville opened up this rich district to the world.

Brazilian Carbons

How to Judge the Values of the Different Varieties Used for Diamond Drilling

By J. K. Smit*

Brazilian carbon is the hardest mineral that is found. It is a stone of volcanic origin, found in decomposed or water-worn conglomerate only in the State of Bahia, Brazil, especially in Chapada, Morro de Chapeo, Lencoes, and San Isabel.

The stones are still obtained by the old-fashioned method of washing, and the total output amounts to about 30,000 carats yearly, made up of stones from the smallest fragments to those weighing about 500 carats.

Before the year 1870, when diamond drilling was yet unknown, the price was no higher than 1 shilling per carat. At that time the carbons arrived at Amsterdam in small barrels, and were ground into powder with which white diamonds were polished. After diamond drills came into use the prices increased enormously, and until the year 1908 the quality of the carbons did not much influence their price.

During the crisis of 1908, however, there were but few buyers, and prices on inferior qualities of carbons went very low. Prime qualities could be made to keep up their prices, but the market was overstocked with inferior stones, which fell even to about a quarter of the price of prime qualities.

After 1908 there was again a great demand for carbons, and prices went up accordingly. The difference in price as to quality, however, has kept, and this is certainly as it ought to be.

Carbons, like white diamonds, were formed under a very high pressure; yet there is a relatively great difference between the two, as the structure of the latter (barring a few exceptions) exists in very thin layers, and they are easy to cleave.

The carbons, however, have a compact structure, for which reason they are more suitable for drilling than white diamonds, as the latter are more apt to break on account of their lamellar structure.

Some carbons consist of different parts that have grown together; and the cleaving of carbons is therefore a very risky matter, the more so as the inner structure cannot be judged by seeing the stone on the outside.

Carbons found in different places are distinguished from each other; those from Japada are for the greater part not porous, and have as a rule very fine crystals. This sort may be best recommended. Next come those that are found in Morro de Chapeo. They generally have a shining coat, and most buyers wrongly prefer them to Japada stones.

It is true they look best, but "fine feathers do not make good eating birds"; and by far the best way is to buy split carbons so as to see the stone on the inside and judge of its hardness. A carbon must be fit for use until nearly the whole of it has worn away.

The shining coat of a carbon *seems* to be harder than the stone really is. This is because the coat is smooth. To give an example: If a piece of plate glass and a piece of ground glass are tested with a steel pin, it will be found that the steel does not scratch the plate glass, whereas it leaves a deep incision in the ground glass. This does not teach that plate glass is the harder, but that it has a very smooth surface on which the steel takes no hold, and that, just as with the shining carbon, the greater hardness is only in appearance.

If it were the shining that made the stone better fit for drilling, it would be very easy to polish shining sides on the carbons.

Buyers will be wise always to take split carbons, as it is possible to examine the degree of hardness of the stone.

Judging the quality of carbons is difficult, and even with a 20 years' experience errors are possible; it is no wonder, there-

fore, that mistakes are made if one has only occasionally to deal with the article.

Stones that are very porous and look like coke are objectionable.

Stones are sometimes judged by their specific gravity; this, however, is not a reliable test. Some stones with high specific gravity are not of the desired hardness, and drilling concerns of long standing have confirmed this opinion.

The only absolutely sure test for the hardness of a carbon is by means of scratching with a hard diamond. In this way it soon appears which stones wear away quickly, less quickly, slowly, or hardly wear away at all.

As a test stone, take a hard Brazil ballas (as hard as the best carbon) and with this scratch the side—by preference the split side—of the carbon. In this way one is able to ascertain with fair accuracy the degrees of hardness of carbon.

By putting the stones to this test, one will find that there is no need of paying fancy prices for carbons with a shining coat, and will be convinced of the advantage of using the better split carbons.

By applying the test stone, carbons are assorted in six different grades.

The first and second grades are suitable for very hard work.

The third and fourth grades are of good medium hardness, and at present the market price for these is low in comparison with the work they do, in fact their prices are only about half of the first and second grades. For this reason it is advisable to buy the third or fourth grades for medium hard rock; as fine, close-grained carbons often offer less resistance to shocks than medium grade stones.

The fifth and sixth grades are the cheapest stones, and suitable for drilling soft formations only.

These last two grades are not recommended and it is much more advisable to take good borts than bad carbons, as good borts are harder, cheaper, and easier to pick out.

Carbons are found in different colors. Most of them are gray, but greenish and reddish shades are also found. The green and red colors are caused by copper or iron oxides that were in the stones at the time of their formation. Grayish stones that have a split side like broken steel, greenish stones, and reddish stones that show very small crystals, are the best.

Some buyers are strongly prejudiced against carbons that, by rolling amongst the gravel of the river, have got rounded sides. In this, however, they are wrong. The hardness of these so-called river stones is readily determined for carbons to be used in a diamond drill, and rolled stones that have become shiny are very hard, whereas stones that have remained rough, although all their sides have been rounded, are not to be recommended.

Every diamond driller knows that carbons that prove wear by showing shiny sides are the best.

Crystallized stones with very small crystals are as hard as the best carbons, although many people have a less favorable opinion about them; they are much like Brazilian ballas. Stones with large crystals, however, are not to be recommended, as will be shown by applying the test stone, because large crystals are more apt to break. It is advisable to use only the best grade carbons (or Brazilian ballas, if they are to be had) for drilling the hardest rocks, such as quartz, granite, conglomerate, etc. For the softer formations, such as shales, slate, sandstone, etc., good borts and Cape ballas will answer.

For drilling sandstones in which the steel about the crowns of the bit wears quickly away, so that the stones are often lost, it is more profitable to use the cheaper borts and Cape ballas than carbons.

Considering the structure of carbons, it will be good to avoid all hammering in mounting the stones and in drilling not to expose them to shocks, as diamonds, although they can bear a very heavy pressure, are not able to resist blows. It is advisable to use stones of cubical, spherical, or oblong shapes for diamond

*A. Smit, Pantare Middeleeuw No. 2, Holland.

drilling; however, a hard stone badly shaped is better than a soft one well shaped.

Brazilian ballas is a kind of white diamond which is distinguished by its structure. White diamond is composed of thin layers; ballas, however, is not. In ballas, crystallization has taken place round one center; accordingly the hardness is as great as that of the very best carbons, for which reason they are used for test stones.

Ballas are very rare; only a dozen of larger sizes are found on an average every month.

The fact that one cannot be mistaken as to their quality—every ballas being hard—is in itself sufficient to recommend them. The cutting side is small, it is true, as the stones are, as a rule, globular; still it will prove a good practice to have a few of them in the crown to cooperate with the carbons when drilling hard rock. They will do excellent work. The price of Brazilian ballas is the same as that of the best carbon.

Borts are impure white, brown, black, or yellow diamonds that have less value for polishing than for industrial purposes. The different kinds are Cape round borts, Cape ballas, and Brazilian borts.

On account of their lamellar structure they are not recommended for drilling very hard rock, as they are too apt to break.

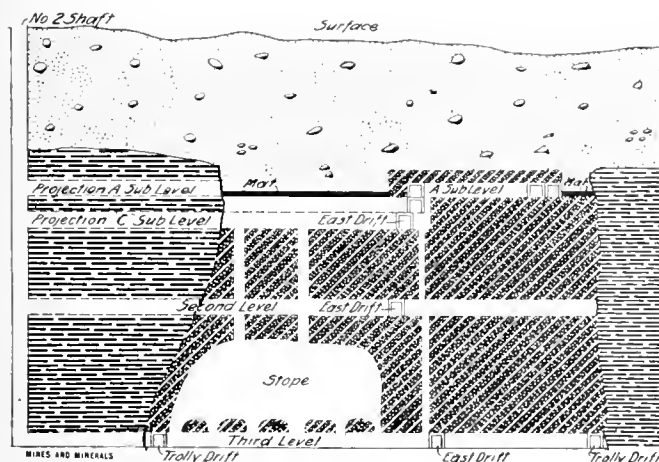

FIG. 1

Top Slicing at the Caspian Mine

A Method by Which the Ore Is Mined Off the Top Directly Under the Overburden

The following method was described by Wm. A. McEachern in the Proceedings of the Lake Superior Mining Institute:

The Caspian ore body was found in 1900 by churn and diamond drilling. The surface averaged 130 feet and many of the holes were only chopped into the ledge to determine the best location for a shaft. In January, 1902, No. 1 shaft was started. This was a drop shaft and was landed April, 1902, with difficulty, on account of sand and water. The shaft was continued to 380 feet. From the shaft, cross-cuts were started on the second and third levels and continued across the ore body. Drifts east and west and then cross-cuts, 50 feet apart, parallel to the main cross-cut, were continued to the rock. No. 2 was also a drop shaft, sunk to the third level and used for lowering men and timber.

Between the second and third levels, nine stopes were developed. These were started directly over and about 10 feet above the back of the cross-cut. The method of mining was back or overhead stoping; that is, drilling holes into the ore overhead

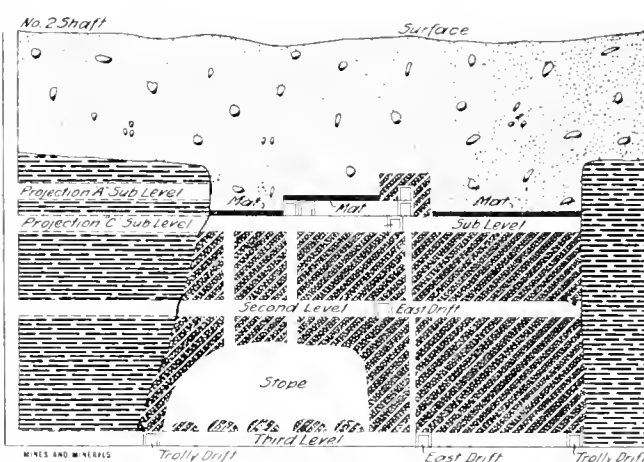

FIG. 2

For softer and regular formations, such as sandstone, shales, slate, etc., they are excellent; moreover, their price being about one-quarter that of carbons, makes them attractive.

They are harder than bad quality carbons, and another advantage is that it needs no expert to judge whether they are of good quality.

In selecting borts one must be careful to take stones that are not cracked, as these stones easily break.

Stones of regular structure are less strong than those whose layers have grown together in an irregular way, as the grain is in different directions so as to make the stone more able to resist shocks.

Ballas are found also among Cape diamonds which are much harder than borts although not so hard as Brazilian ballas. Cape ballas are also scarce and in great demand. With good Cape ballas a very hard rock can be drilled.

After Cape ballas, Jagerfontein and River borts follow in hardness. These three kinds are the hardest among all South African diamonds.

At last we have come to the Brazilian borts. Large stones of this kind are seldom found in Brazil. The difference in hardness does not justify the great difference in price, and only an expert—and he not always—can tell the genuine Brazil borts from the other kinds.

Attention is called to the fact that for drilling medium hard formations many drillers use partly carbons, partly borts, or Cape ballas, and this is always the cheaper method.

and blasting, then standing on the broken ore and drilling another round of holes. The average size of the stopes was 100 feet long, 25 feet wide, 50 feet high, leaving a 25-foot pillar between stopes.

The ore near the ledge could not be mined until the water was drained from the sand. Very little work was done on the first level, now called "C" sublevel, until 1908. This level was then extended and cross-cuts started directly over the cross-cuts on the second level. Small raises were put up from this level in various parts of the mine. A 12-foot test hole was drilled ahead of each cut to ascertain the height of the sand, then 6-foot holes were drilled and blasted. When the test hole reached the sand, 6-foot holes were again drilled and blasted, leaving 5 to 6 feet of ore to hold up the sand. Three more holes were drilled to hasten the drainage. Forty-eight raises were put in and some ran with little decrease in water for over a year.

Top slicing at the Caspian mine is the method by which the ore is mined off at the top in slices 10 feet thick and directly under the overburden. In June, 1908, a raise 20 feet high was started from No. 5 east cross-cut on the first level. This was a cribbed raise and had two compartments, one for ladders and one for ore. The height was determined by the distance to the ledge. When this raise was completed other raises were started and cross-cuts east and west were started from them and continued to the rock. This was the beginning of the top, or "A." sublevel. The cross-cuts were timbered, using 8-foot caps and legs and lagging in the back. Connecting the cross-cuts on the end completes one slice as shown on plan in Fig. 3. The machine was

back and another slice 8 feet wide was started. These were timbered the same as the cross-cuts and lagging laid on the floor when the slice was finished. When the fourth slice was finished the middle legs of the first two sets (shown on plan as small circles) were drilled and blasted, bringing the overburden to the floor. The mat which prevents the sand from mixing with the ore consists here of 5 feet of ore left behind, and the caps and legs of timber sets and lagging on the back and the floor. The slicing of the pillars was continued until only a 10-foot pillar was left at the main drift. (Cross-section Fig. 1.) This operation was carried on in as many cross-cuts as the demand for ore required, and pillars were left on each side of the main drift for the transportation of timber to the two succeeding sublevels.

"B" Sublevel.—The back of this level was even with the mat and is 10 feet below "A" sublevel. On "B" sublevel there were three points where the operation differed from "A" sublevel:

- (a) No back holes were drilled as the ore stripped off the mat.
- (b) The timber was kept closely to the breast to hold up the mat.
- (c) Boards were used on the floor instead of lagging.

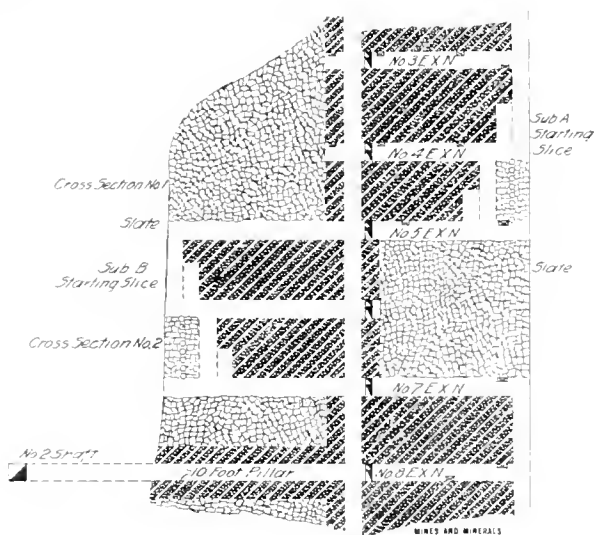

FIG. 3. PLAN.

Cross-section Fig. 2 shows "B" sublevel on the west side half drawn back, and on the east side finished with the exception of a 10-foot pillar to support the drip. On the east side is also shown a cross-cut in "C" sublevel ready for slicing. In any part of the mine, slicing or cross-cutting is not begun until the ore is taken out above it.

Within the next 10 years, if one sublevel a year is finished, the sublevels will be down to the stopes. The stopes must be filled with ore and trimmed and then cross-cuts run between the stopes to the rock. The pillars will be sliced the same as before.

When the overburden is let down, part will rest on the floor of the pillar and part on the filling in the stope. It will be necessary to carefully watch the chutes to the stope, as lowering the mat will let sand from the mat and allow sand to mix with the ore.



Bully for the Old Five-Gallon Oil Can

There are a great many mining men in this country who are not satisfied with the agencies enumerated in the following list. In a recent issue of a camp newspaper, the Wonder Camp, the editor quite justly, however, that such persons have not been mentioned in the mining camps of the West, for the same agencies of kerosene are everywhere, as the editor of the above mentioned optimistic editor under the above title.

"Many evils are charged to the Standard Oil Company, but there is one blessing for which the big monopoly must be given credit. The empty gasoline or kerosene can is a blessing to the denizens of the desert. Four of them filled with water make just the right load for a jackass. One holds just a dime's worth of water. Split endwise, a bachelor's dishpan is the result. An experienced housekeeper cannot do without them. Cut the top out of one and you have a vessel just the right size to boil a ham. Cut around three edges of one end and you have a box with a door, which mice cannot molest. If the roof leaks cut up an oil can and patch it. If you want an ash pan, cut one in two and there you are. Partly fill half of one with ashes and you have a spittoon. In fact, if you want to make anything, get an oil can and go to work. Long live the oil can! Hoch the oil can! Vive the oil can! Hurrah for the oil can!"

We have seen the cans unsoldered and used as both roofing and clapboarding for cabins.



Removing Moisture From Iron Ore

By John S. Nicholl*

One of the simplest methods of increasing the value of wet iron ore is to drive off the moisture, as it is the interstices between the nodules that reduce the resistance to the blast as offered by fine ores when charged wet. In reducing the moisture, from, say, 21 per cent. to 8 per cent., the ore is discharged by the dryer in nodules varying in size from peas to marbles. The usual method of drying consists in putting the ore through a double-shelled dryer. The material enters the space between the shells at the feed end, and on account of the revolution of the dryer, together with its inclination, is carried through to the discharge end, meeting on the way the hot gases which have previously passed through the inner cylinder.

A recent test made on a rotary dryer at an iron mine in New Jersey, gave an efficiency of 89.05 per cent. The dryer was installed in the open and driven by a vertical steam engine which also revolved the fan. By increasing the fan speed, the capacity of the dryer was increased in almost direct proportion. It is claimed that the installation has proved to be a profitable investment owing to the increase in the price obtained for the ore. Table 1 showing the duty and conditions governing tests made will be useful to others who have wet ores.

TABLE 1. ORE-DRYING TEST AT MINE NO. 3 OF PEQUEST COMPANY, BUTTSVILLE, N. J.

	Test No.	
	1	5
Temperature of atmosphere.....	73°	88°
Temperature of ore mined.....	59°	60°
Temperature of ore discharged from dryer.....	116°	185°
Temperature of fan exhaust.....	120°	
Per cent. of moisture in ore mined. (All day average)	22.4	20.29
Per cent. of moisture in material discharged from dryer.....	8.0	8.34
Per cent. of moisture in material after standing in office 24 hours.....	4.3	
Amount of material fed to the dryer in tons per hour	5.447	17.59
Time, minutes.....	60	60
Rate per hour.....	5.147	17.59
Fuel oil burned, gallons.....	18.000	67.5
Fuel oil burned per ton of ore delivered to dryer, in gallons.....	3.30	3.83
Pounds of water in 1 ton of ore as mined.....	448	405.80
Pounds of water in ore as discharged by dryer.....	135	145.05
Pounds of water evaporated per ton of ore delivered to dryer.....	313	260.75
Water heat, British thermal units.....	47,890	39,634
Heat of evaporation.....	302,700	252,145
Material heat.....	22,120	49,819
Heat in water material discharged by dryer.....	7,695	18,131
Total heat, British thermal units.....	380,405	359,729
Heat in fuel oil burned per ton of ore delivered to dryer.....	434,500	503,568
Efficiency of performance.....	87.55%	71.04%
Tons of ore to be mined per ton of dried ore delivered	1.186	1.149

* 170 Sumner St., Boston, Mass.

Mechanical Sampling of Ores

Various Devices for Taking Representative Samples From Large or Small Quantities of Ore

By O. Binder, Wiesbaden

It is evident that an ore analysis has a practical value only when the analyzed small ore sample has exactly the same composition as the bulk from which it has been taken. But since the sampling of ore by hand for assaying purposes is rather difficult, it has been the endeavor, for a long time, to have this work performed by mechanical contrivances, and especially on account of the fact that by taking a sample through mechanical means any arbitrary influence which may cause intentional or unintentional mistakes is entirely out of the question. It is quite interesting to examine the mechanical contrivances which have been invented for the purpose of obtaining true samples. The mechanical ore sampling has been very exhaustively studied in the United States, especially for copper, gold, and silver ores, and a few of the contrivances constructed for this purpose are here described.

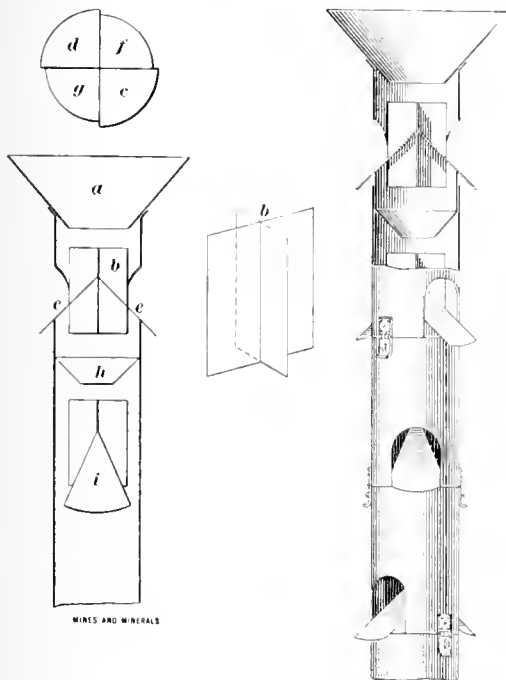

FIG. 1. PIPE SAMPLER

The pipe sampler shown in Fig. 1 consists of an 8-inch pipe which is provided with a funnel *a* and two tin plates *b* which intersect each other at right angles. The ore to be sampled is first crushed and then, when placed in the funnel *a*, drops upon the intersection of the two tin plates *b* and is thus separated into four parts. That part of the ore which drops into the two corresponding triangles *c* and *d* slides outward on two inclined planes *e*. The other part of the ore in triangles *f* and *g* drops into a second funnel *h* directly below, from there again upon cross-plates *i*, and the same process is repeated. Single pipes may be joined in accordance with the sized sample desired. After the ore has passed the first plates, one-half is retained as a sample; the other one-half is discarded; after passing the second plates, again one-half is retained, etc. Therefore, if seven cross-plates are used, .78 per cent. of the ore placed in the first funnel is obtained as a sample.

The principle of this apparatus is based on the well-known quartering test, which, through this contrivance, can be automatically performed in succession an indefinite number of times. If several pipes be used, the ore should be crushed into small pieces.

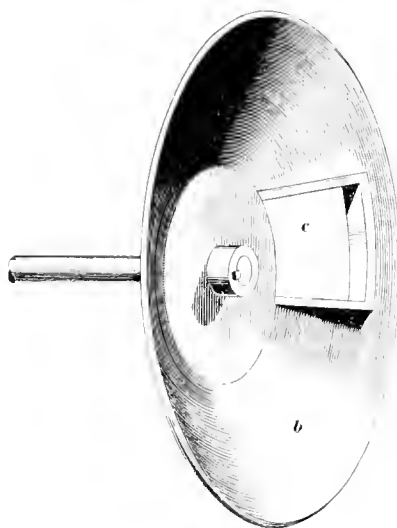

FIG. 2. SNYDER SAMPLER

The Snyder ore sampler shown in Fig. 2 consists of a round cast-iron pan *b* which has on its inside slope an opening *c*. The cast-iron pan is attached to the end of a horizontal shaft which is provided with one loose and one stationary strap disk.

The ore from which the sample is to be taken is sent through a pipe in such a manner that it drops upon the slanting surface of the disk, which makes from 10 to 30 revolutions per minute. The main part of the ore slides off the slanting disk and drops in the ore receptacle, while the sample itself falls through the opening in the disk at the moment when the opening passes the pipe and thus reaches the sample receptacle, unless it is to be further reduced in size. It will be noticed that the two sides of the opening through which the sample passes converge toward the axis of rotation, so that the part of the opening near the circumference will pass through the stream of ore in exactly the same time as that nearer the axis, and will cut out equal proportions of ore from all parts of the stream.

The samplers are made in different sizes to meet the demand of the user who depends on the speed of rotation for the size of the sample.

The Vezin sampler shown in Fig. 3 consists of two hollow

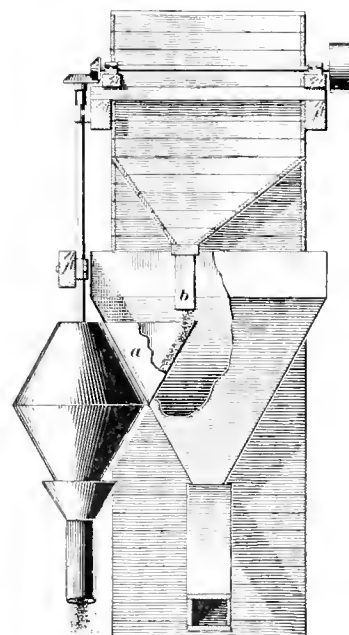

FIG. 3. VEZIN SAMPLER

cones joined together at their respective bases and mounted on an iron frame. On the upper cone there are one or more scoops *a* in a radial position. These scoops move through the ore falling from spout *b* and thus cut out the sample. The latter drops into the lower cone and from here into the receptacle for the sample. The weight of the samples depends on the number and size of the scoops and upon the velocity of rotation of the apparatus.

This ore sampler is also constructed with two scoops and double cones, one above the other. In this case a mixing cylinder of steel plate is constructed between them. After the samples have passed the first cone they are mixed in the cylinder—the more the ore is mixed, the better the samples—then the ore is dropped into the lower cone and there is sampled once more. This apparatus may be used for large or small pieces of ore.

The Bridgeman ore sampler simultaneously produces two samples, independent of each other, which is highly important when rich ore is sampled and check analyses are needed for confirmation. With rich ore this double sampling is necessary, as otherwise the final calculations would be analytical and probably not correspond with the average value of the ore.

A cross-section of the apparatus is shown in Fig. 4. The

basis for obtaining the sample is as follows: The ore drops through tube *a* upon the separator *b* which is divided into eight parts and is revolved horizontally by hand, or some mechanical contrivance. The separator divides the ore at each rotation into eight parts, four of which drop into funnel *c*, and the remaining four through space *d* leading to the ore receptacle. At a uniform velocity of the flow of ore, and at an equal velocity of rotation

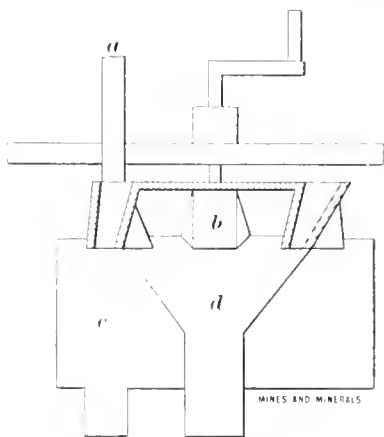

FIG. 4. BRIDGEMAN SAMPLER

of the separator, the material will be divided into two equal parts by the first separation. Since the apparatus can easily make 100 revolutions per minute, 800 parts of ore can be received in this time, a procedure through which an extensive division can be obtained in a short time. If, after using the apparatus with only one separator, the samples should be still too large, the operation may be repeated again and again until the desired weight has been reached.

The larger sizes of apparatus have, in addition to the separator of eight parts, two additional separators, one beneath the other, and in the form of reversed hollow cones. These rotate around a vertical shaft, the middle separator rotating in a direction opposite to the other two. The proportional velocities of rotation of the three separators is 5:15:45 per minute. The two lower separators are arranged in such a way that they cut out as samples one-fourth of the ore that passes through them. In each separator, on the surface of the cone, there are large apertures through which the samples will drop, while the bulk of the ore glides downward and thus finally drops out through the center of the apparatus.

One size has an average capacity of about 20 tons an hour. It may be used for sampling large pieces of ore and produces a final sample of from 1 to 2 per cent. It also can produce two additional samples entirely independent of each other, by constructing below the separator two funnels beside each other for the samples, with which correspond the concentrically arranged apertures in the surfaces of the cones of the two upper separators. The sampler has a base of 3 ft. x 4 ft., and is 7 feet 6 inches high. The apparatus works automatically, is very compact, needs little power, few repairs, and little supervision. The second size is for sampling smaller quantities and produces only one sample; its capacity is about 2 to 4 tons per hour.

The sampler can be adjusted so as to obtain small or large samples of the different ores. When, for instance, the top separator takes a sample with only four partitions, the quantity of the final sample is $\frac{1}{4} \times \frac{1}{4} = \frac{1}{16}$ of the bulk; if only one partition is used, $\frac{1}{8} \times \frac{1}{4} \times \frac{1}{4} = \frac{1}{128}$ of the original quantity. The first sized apparatus is generally arranged in such a manner that six partitions separate the ore passed through them for the ore receptacle, while the two remaining partitions serve for the production of a separate sample each. If the quantity of ore is 20,480 pounds, two separate samples of 160 pounds each can be had per hour, which again can be decreased by means of another sampler to $\frac{1}{2} \times \frac{1}{4} \times \frac{1}{4} = \frac{1}{32} = 5$ pounds.

The work of sampling in this manner is done quickly and with precision, about as quickly as a flow of ore can pass through an opening 1 inch in diameter, and with by far more dispatch than can be done by hand; moreover, the entire proceeding is less expensive. There is another advantage: The entire flow of ore is diverted for a certain length of time, a process which is in conformity with highly approved tests.

The Hopkins mechanical ore sampler, Fig. 5, consists of a scoop *a* and a cog wheel *b* with worm-gear *c*. The entire arrangement is figured out in such a way that the scoop is lowered at regular intervals, whereby the sample drops in the scoop *a* which being raised permits it to slide into the funnel *d*, and through this into a suitable receptacle. The worm-gear *c* is operated from any convenient power.

This arrangement is exceedingly simple and works with accuracy. The Hopkins ore sampler is the only one which takes the sample from the whole width of the launder; it may be used for a flow of ore as well as for wash ore, or from a launder or pipe line. Fig. 5 represents the apparatus for a wooden launder. In order to use the ore sampler for pipes, it is only necessary to close the upper end of the cross-section of the channel, and to drill a suitable hole into the closing partition into which a pipe is inserted and screwed down.

As it often happens that samples are taken from large quantities of ore, sampling mills have been erected for the purpose of doing nothing else. The entire bulk of ore passes through the mill and samples are taken continually. The ore drops finally into an ore receptacle, and when the latter is filled, into another. From an analysis of the samples thus obtained, the value of the ore in each bin is known as well as the constituents it contains.

The sampling process consists essentially of crushing the ore by machinery, after which sometimes additional sampling is done by hand.

The regular smelteries have their own establishments for ore sampling, whether they smelt their own or customer's ore, as only by taking samples can they be assured of obtaining good results.

Other metallurgical plants, for instance concentration and cyanide or lixiviation mills, also have their own sampling establishments, in order to be able to determine beforehand the value of the ore and thus ascertain their percentage of recovery.

In Fig. 6 the elevation and ground plan of such a plant is shown. The process is as follows: The ore is first deposited in a crusher *a*; here it is broken into pieces of about 3 inches in diameter. These drop into the elevator *b*, which lifts them to the highest point of the plant, where they are received by the Snyder ore sampler *d*. The latter is 60 inches in diameter and takes 15 per cent. from the bulk of the ore as sample. The remainder drops into a rotary funnel *c*, located below the ore

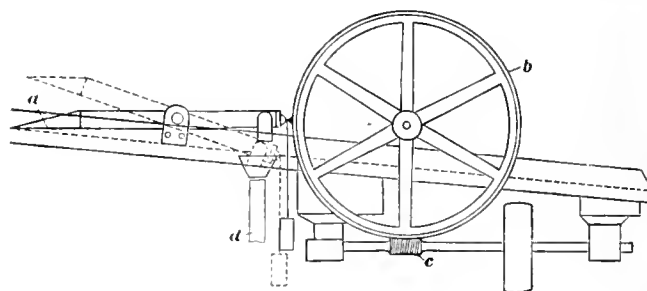

FIG. 5. HOPKINS SAMPLER

sampler. This funnel drops the discarded ore into one of the ore bins *n*, which are constructed below all around the plant. The sample drops into a crusher *f*, the opening of which is from 9 to 15 inches in diameter, and is reduced to a size about $1\frac{1}{2}$ inches in diameter and then again drops upon a 42-inch sampling apparatus *g*. Here once more 20 per cent. of the ore is taken off as a sample; the discard drops through a conduit into an elevator *h*.

The latter raises the discard to chute *e* which slides it to the bin in which the bulk of the ore is placed. The sample drops again into a crusher *i*; and after it has passed this apparatus the sample has been crushed to three-fourths of an inch in diameter. This small-sized sample is split once more by a 27-inch sampling apparatus.

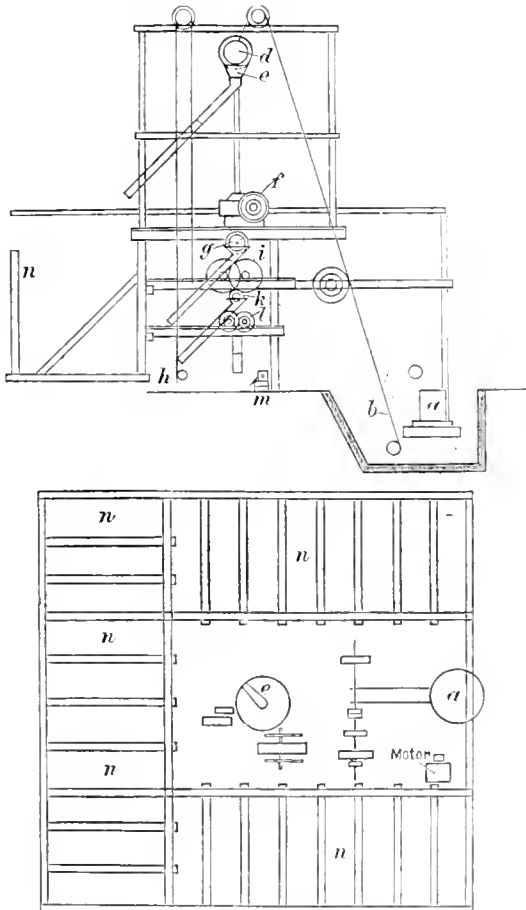

FIG. 6. PLAN AND ELEVATION OF SAMPLING MILL

which cuts out another 20 per cent. of the ore, while the remaining ore drops, as before, into an elevator *h* and thus reaches the discard in the ore bin. The sample is now further reduced by a roll crusher to one-fourth of an inch in diameter and from there it drops on disks at the ground floor of the plant. The sample is picked up by hand and ground up by sample mill *m*.

The plant described here delivers a sample of *b* parts in 1,000 parts of the ore to be sampled, as may be seen from the figures given above. The capacity of this plant is 35 tons per hour. Smaller plants, which are arranged precisely the same, produce from 5 to 8 tons per hour. The 6-pound sample is sampled again in the laboratory, as it is not, and should not be considered as homogeneous. For this purpose it is crushed to pass a fine screen, probably 100 mesh, then quartered until the sample contains from 200 to 300 grams, then mixed and resampled until the assay batch has been obtained.

來 來

As a lubricant for air compressors, graphite has a number of attractive qualities. It is generally conceded that ignitions and explosions in compressors are due to the kind and quality of the lubricant used. The best oils are likely to give off vapors and must be used sparingly. Soapsuds is also used, but must be applied in large quantities and is apt to rust the machinery when not in use. Graphite is without these deleterious qualities. It is inert, unaffected by high temperatures, and cannot vaporize, ignite, or cause explosion.

Gasoline Industrial Locomotives

Difficult Conditions to Which the Internal Combustion Motor Has Been Adapted

By Frank C. Perkins

It is not much over one year since a description of a successful gasoline mine locomotive appeared in MINES AND MINERALS, yet since that article this kind of haulage power has increased all over the world with wonderful rapidity. The use of gasoline locomotives is not confined to mine haulage by any means, but has been extended to all kinds of industrial enterprises and even plantations.

Recently a gasoline locomotive has been installed in the Canadian Coal Consolidated, Ltd., mine, at Frank, Alberta. The locomotive, which is between 8 and 10 horsepower, pulls a load of 25 tons besides the weight of 10 cars, in all, a load of approximately 35 tons, at a speed of 3 miles an hour.

The trouble found with this locomotive is lightness, since its weight, 5½ tons, prevents it from pulling more than 9 empty cars, on a grade of 7 per cent., 400 feet in length. To overcome this inconvenience the company has ordered a second locomotive, which is to weigh 7½ tons and be of 18 to 20 horsepower. The locomotives are fitted to run both ways at two different rates of speed, 3 to 5 miles for the first, and 5 to 7 miles for the second. This is an excellent feature, as it permits the engineer to always be at the head of the trip so he can always see ahead of it. The exhaust takes place in a safety box provided with coolers and prevents the escape of any flames or hot air to the surrounding atmosphere in the mine. The locomotive in use at present consumes about 12 gallons of gasoline in 10 hours.

The locomotive in Fig. 2 is capable of hauling 25 empty ore cars 2 miles into a mine and bringing the cars out loaded. A section of adit in which it runs is shown in Fig. 1 and from the dimensions given it can be seen that the two make a close fit. The adit is not only narrow but is winding; has a grade of 1 foot in 68 feet and in one place the rails are a couple of inches under water. The locomotive is rated at from 12 to 14 horsepower and has two gears for speeds of 3 and 6 miles per hour. This locomotive replaced 4 horses and drivers.

In a stone quarry there is another locomotive pulling from

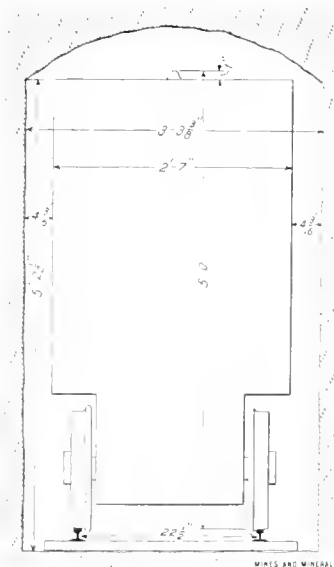

FIG. 1. CROSS-SECTION OF ADIT AND LOCOMOTIVE

350 to 400 tons of stone to the rock crushers, where it is broken for ballast.

In India and the Far East gasoline locomotives have been introduced for several purposes and even on farms. At the

Flame-side works in England a small gasoline locomotive of 10-horsepower hauls coal on a 20-inch gauge track, between the power-house and the power-house coal bins, and successfully negotiates a grade of 1 foot in 30 feet with 8 tons of coal.

From the foregoing sketch it does not require a vivid imagination to anticipate that in the near future gasoline locomotives will have a much wider field of usefulness than can be obtained by other systems of industrial haulage. According to grades and track conditions, one gasoline locomotive will replace

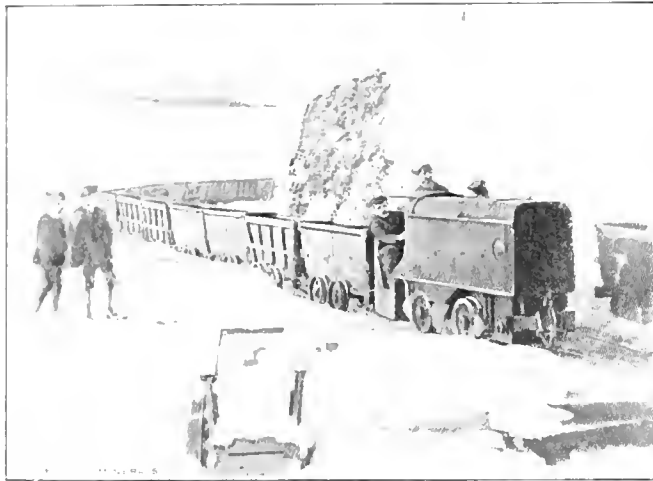

FIG. 2. GASOLINE LOCOMOTIVE AND TRAIN

one horse and drivers in mines, and is cheaper, because it needs less stable attention. The locomotive is readily managed by unskilled labor and will run on kerosene, gasoline, benzine, benzol, and beet alcohol. Unlike steam locomotives, there is no boiler depreciation, insurance rates, or inspections, and there is no waste of fuel and time in raising steam.

Unlike the electric locomotive it will run anywhere that rails are laid down to carry it and will start with a turn of a handle at any time. The gasoline locomotive is said to be less dangerous than steam and electric locomotives, as the machines are absolutely fire and explosion proof.

They are cheaper than steam or electric locomotives, and are now successfully running on tracks that have shaken other locomotives to pieces in a few weeks. The gasoline locomotive engine may be of the horizontal or vertical type, but balanced and fitted with a flywheel the bulk of whose weight is in its rim. The engine is speeded to about 300 revolutions per minute and can be accelerated 20 per cent. over this if required. When throttled down (during rests) the engine speed is only 150 to 170 revolutions per minute, and consumption of fuel is very little like the vibration is practically nil.

The carburetion is by a special appliance, in one locomotive at least, so that there is never any explosive mixture outside the firing cylinder and this is the only system that should be used in "fiery" collieries. The fuel consumption should not exceed one gallon of gasoline per brake horsepower hour at full speed. The fuel metering device should be such that the locomotive will run on kerosene or fuel between gasoline at .700 and distillate at .750 without any special adjustments, other than

changing the gears by spur wheels and metal to metal contact. The gears should permit them to be slipped when necessary. The transmission is usually by a chain drive, the chain running in an oil bath and the life of the chain should be at least 3 years at least.

The control is by one wheel, movement of this wheel in one direction engaging the forward motion clutch, and in the other the reverse motion clutch, while mid-position gives free engine during rests and when starting up the motor. The speeds can be thrown in and out without the least care, with no ill effects. Lubrication of the different makes of gasoline locomotives is accomplished to agree with the ideas of the maker on the subject, however it is an important point for the purchaser. Most gasoline locomotives have so far been constructed without connecting-rods, the drive being on all four wheels. This is feasible when sufficient weight is allowed to rest on all wheels to transmit the full horsepower even on inferior tracks without slipping. With wet or slippery rails, a sand-box gear is provided and actuated by a lever in the driver's cab. The accelerator acts on the governor, and a lever is set by the driver in his cab to give any desired rate of progression, within speed limits. The governor should act on the inlet valve in conjunction with the gasoline admission valve, so as to insure a perfect mixture for explosion. The gasoline and water tanks should be of steel and tested under hydraulic pressure.

The locomotives are enclosed by dust-proof doors, and fastened by keys which the driver keeps in his possession so that any outside interference with machinery is obviated. If special arrangements are made in connection with the ignition and expulsion of the exhaust gases, the locomotive may be made free from all smell, sparks, or flame, or from the least danger of fire or explosion, and it is claimed that many hundreds are running underground in "fiery" collieries in Europe. The dimensions, weight, and consequently haulage power are dependent on the place in which the locomotive is to work. The makers will furnish data on these subjects after a customer's wants are known. The haulage power of one maker's locomotives on level and grades is given in the following table:

TABLE 1. HAULAGE POWER OF GASOLINE LOCOMOTIVE, IN TONS

Horsepower of Engine	Level	Grades			
		1 in 250 .4 Per Cent.	1 in 100 1 Per Cent.	1 in 33 3 Per Cent.	1 in 20 5 Per Cent.
8	22	16	10	3	1
20	65	45	29	11	6
35	115	75	50	20	10
50	150	100	73	30	15
70	230	155	100	43	24

來 來

Cost Per Foot of Driving Drifts, Goldfield, Nev.

	Laguna Drift	Combination Drift	Jumbo Drift
Distance driven, feet.....	260	228	208
Days worked of two shifts each.....	30	27½	29
Advance averaged per 8-hour shift.....	4 ft. 4 in.	4 ft. 2 in.	3 ft. 6 in.
Number of men working each shift.....	2	2	2
Distance trammed, feet.....	800	1,200	1,200
Machine-drill charge.....	\$.41	\$.37	\$.51
Timber.....	.64	.26	.21
Explosives.....	1.00	.93	1.02
Labor.....	4.24	2.91	4.15
Hoisting.....	.28	.63	1.02
Total cost per foot.....	\$6.57	\$5.10	\$6.91

In calculating the machine cost, which covers the cost of machine drill repairs, new parts, lubricant, and compressed air, the average figure of the last year for this item is used, which was \$1.83 per machine shift.

In connection with the hoisting it should be noted that part of waste from drift was used as filling in the stopes.

From the foregoing sketch it does not require a vivid imagination to anticipate that in the near future gasoline locomotives will have a much wider field of usefulness than can be obtained by other systems of industrial haulage. According to grades and track conditions, one gasoline locomotive will replace

one horse and drivers in mines, and is cheaper, because it needs less stable attention. The locomotive is readily managed by unskilled labor and will run on kerosene, gasoline, benzine, benzol, and beet alcohol. Unlike steam locomotives, there is no boiler depreciation, insurance rates, or inspections, and there is no waste of fuel and time in raising steam.

Unlike the electric locomotive it will run anywhere that rails are laid down to carry it and will start with a turn of a handle at any time. The gasoline locomotive is said to be less dangerous than steam and electric locomotives, as the machines are absolutely fire and explosion proof. They are cheaper than steam or electric locomotives, and are now successfully running on tracks that have shaken other locomotives to pieces in a few weeks. The gasoline locomotive engine may be of the horizontal or vertical type, but balanced and fitted with a flywheel the bulk of whose weight is in its rim. The engine is speeded to about 300 revolutions per minute and can be accelerated 20 per cent. over this if required. When throttled down (during rests) the engine speed is only 150 to 170 revolutions per minute, and consumption of fuel is very little like the vibration is practically nil.

The carburetion is by a special appliance, in one locomotive at least, so that there is never any explosive mixture outside the firing cylinder and this is the only system that should be used in "fiery" collieries. The fuel consumption should not exceed one gallon of gasoline per brake horsepower hour at full speed. The fuel metering device should be such that the locomotive will run on kerosene or fuel between gasoline at .700 and distillate at .750 without any special adjustments, other than

changing the gears by spur wheels and metal to metal contact. The gears should permit them to be slipped when necessary. The transmission is usually by a chain drive, the chain running in an oil bath and the life of the chain should be at least 3 years at least.

The control is by one wheel, movement of this wheel in one direction engaging the forward motion clutch, and in the other the reverse motion clutch, while mid-position gives free engine during rests and when starting up the motor. The speeds can be thrown in and out without the least care, with no ill effects. Lubrication of the different makes of gasoline locomotives is accomplished to agree with the ideas of the maker on the subject, however it is an important point for the purchaser. Most gasoline locomotives have so far been constructed without connecting-rods, the drive being on all four wheels. This is feasible when sufficient weight is allowed to rest on all wheels to transmit the full horsepower even on inferior tracks without slipping. With wet or slippery rails, a sand-box gear is provided and actuated by a lever in the driver's cab. The accelerator acts on the governor, and a lever is set by the driver in his cab to give any desired rate of progression, within speed limits. The governor should act on the inlet valve in conjunction with the gasoline admission valve, so as to insure a perfect mixture for explosion. The gasoline and water tanks should be of steel and tested under hydraulic pressure.

The "New Metallurgy"

And the East Rand Proprietary Mines—Comparison of Present With Former Conditions

By H. Studler*

In face of the fact that the New Kleinfontein mine, run on conservative lines, with single-stage crushing (according to the annual reports for 1910), still holds the record in reduction costs, against two of the largest progressive mines, I cannot help feeling that metallurgical business on the Rand has become too refined, and that from the introduction of the cyanide process to the present date very little, if any, real economical progress has been made.

As a contributor connected with the Crown mines accuses me, in the *Mining Magazine* (July, 1911) of being apt to flounder in my broader inferences, I have looked up some figures so as to get conclusive arguments in place of mere impressions. I am now ready to say definitely that practically all the metallurgical improvements introduced, and unduly boomed, during recent years have proved disastrous economic failures.

Immense sums were spent during recent years to remodel the old plants, and for their adaptation to the "New Metallurgy," which already had been proved to be based on utterly wrong premises. The result of this expenditure was an increase in reduction costs of at least 1s. per ton, remembering that certain facts (such as cheaper power, larger tonnages dealt with, etc.), which are not peculiarities of the "New Metallurgy," account, in themselves, for a considerable reduction. This shilling on 2,000,000 tons per year, capitalized at 10 per cent., itself accounts for a depreciation of, say, £1,000,000 in the share valuation.

Fine Grinding and Extraction.—In order to review the position 5 or 6 years ago (before the advent of tube mills), I take the representative figures, Table 1, from Table C of Messrs. Denny's memorable paper on "Rand Metallurgical Practice and Recent Innovations":

TABLE 1. EXTRACTIONS OBTAINED ON THE VARIOUS GRADES BY AMALGAMATION AND CYANIDATION
(Abstract from Messrs. Denny's Paper—Table C, 1905)
400 Mesh

Mesh	Weights	Screen Average 10.869 Pennyweights		Final Pulp Average 4.867 Pennyweights		Residue Average .801 Pennyweight		Total Extraction on Each Grade
		Assay Value Per Grade	Individual Extraction	Assay Value Per Grade	Individual Extraction	Assay Value on Grade Per Ton	Total Value on Each Grade	
Per Linear Inch	Per Cent.	Penny- weights	Per Cent.	Penny- weights	Per Cent.	Penny- weights	Penny- weight	Per Cent.
+ 60	33.40	5.50	12.51	4.81	69.76	1.45	.484	73.54
100	17.20	10.00	53.66	4.63	84.40	.72	.124	92.77
150	7.71	13.50	73.17	3.62	92.37	.27	.021	97.95
+200	6.04	18.25	79.93	3.66	93.39	.24	.015	98.67
-200	35.65	14.50	62.03	5.55	92.04	.44	.157	96.98
	100.00	Extraction by amalgam, 55.22 per cent.		Extraction by cyanide, 37.38 per cent.				.801
		Total extraction, 92.6 per cent.						

From these figures Messrs. Denny drew the logical conclusion that in order to get a total extraction of 95 per cent. (as far as these fields are concerned), it is uneconomical to grind ore beyond the point at which 58 per cent. passes 100 mesh. In view of the lessened cost of plant, due to the possibility of quicker treatment of a 150-mesh product, they were rather inclined to

*Engineer of Research Work, Mines Trials Committee, Johannesburg, South Africa.

think that all ore should pass 150 mesh, "as from an ore comminuted to this extent 95 to 96 per cent. extraction should be consistently obtained."

Instead of building upon this sound foundation of conscientious research work and exhaustive data collected from test runs on a practical mining scale, some metallurgists, with the motto: "The finer the crushing the better the extraction," rushed

TABLE 2

I. M. M. Mesh Per Linear Inch	Residue Value on Grade Per Ton Pennyweights	Pulp I Stamp and Tube Mill Combination		Pulp II Single Stamp, 1,600 Mesh	
		Weights Per Cent.	Residue Value on Grades Pennyweight	Weights Per Cent.	Residue Value on Grades Pennyweight
+ 60	1.5	2.3	.0345	8.7	.1305
+ 90	.7	9.8	.0686	16.5	.1155
+200	.5	23.2	.0696	17.1	.0513
-200	.2	64.7	.1294	57.7	.1154
		Total, 100.0	.3021	100.0	.4127

Total extraction on 7.5 pennyweight ore..... 96 per cent. 94.5 per cent.

unthinkingly into an extravagant ultra-fine grinding policy, without regard to economic or other important considerations. In the keen race to beat metallurgical records, they have quite overlooked the following factors:

1. The higher extraction claimed for finer grinding has, in consequence of mistaken deductions, been grossly exaggerated; in criticizing my method of efficiency calculation a writer again falls into the old blunder, already refuted, that the exposure of surface represents the "metallurgical value" of crushing work done. There is not the least objection to adopting this standard, provided all other factors are reduced to this same unit, especially the assay values, which are taken by weight (or volume), and vary therefore at a much slower rate than the surface exposed. From the statement made by Mr. E. H. Johnson (*Journal Ch. M. and M. Society*, July, 1910), that the stamp and tube mill combination produces, for the given cases, 9.5 per cent. more surface than single stamps, the impression is produced, perhaps unintentionally, that the "useful work" is increased in this same proportion. It follows, however, from Table 2, that, on the assumption of average values for the various grades, the higher extraction obtained in favor of the fine pulp is only 1.5 per cent., or 5.4d. in a 7.5 pennyweight ore. This amount is hardly sufficient to repay the higher costs of finer grinding.

2. One of the most important results of the research work executed by the Mines Trials Committee is but the realization of the fact that any classifier with its overflow velocity well adjusted, acts as an efficient concentrator, in which the specifically heavier pyritic particles are preferably retained in the underflow. Roughly, it may be said that the assay values of the plus 60 and plus 90 grades in the overflow are halved, with a corresponding enrichment of the underflow. For instance, 10 per cent. of plus 60 grade of such an overflow, assaying 2.5 pennyweights, yields just as good an extraction as a 5 per cent. overflow, assaying 5 pennyweights. Those experienced in panning know how easily the segregation of pyrites from quartz can be disturbed and upset by hasty and maladroit movements, and it is therefore not surprising that partially banked up and disturbed classifiers are complete failures as concentrators. The abandonment of the old proved Spitzkasten in series, in favor of cones in sets, with or without the much-advertised diaphragm, is also an improvement of a retrograde kind.

3. With the very fine final pulps now generally in use, it is no longer reasonable to take the few percentages left on the plus 60 grade as a criterion for the fineness of pulps. Besides the

inaccuracy of screen measurements (which may amount to 2 per cent. and over), it must be remembered that part of the particles left on the plus 60 grade is of an exceptional flat or long shape, and more amenable to chemical treatment than a similar volume of spherical form; or they are specifically lighter materials, and of a nature quite different from the ore, since they carry neither pyrite nor gold.

4. The profit resulting from higher extraction by finer grinding is practically nullified by forfeiting the good effect which a high percentage of extraction by amalgamation has on the total extraction. Crushing by impact in a mortar box is much more adapted to free the pyrites and gold from their gangue, than the abrasive action of the tumbling contents of tube mills, in which largely the particles are not broken up, but ground down by surface wear. The greater amenability to amalgamation of battery pulps is borne out by the fact that in Messrs. Denny's time, as well as now, an amalgam extraction of 70 per cent. was easily reached, whilst, where the mill plates have been discarded, this extraction has now dropped in most cases to 50 per cent. (South Randfontein mines, 48.0 per cent.; E. R. P. M., Ltd., 50.11 per cent., etc.) Besides the advantage of quick realization of profits, a high extraction by amalgamation has a far-reaching effect on total extraction, consequent on the lowering of gold contents left in the final pulp for cyanide treatment, where only 85 to 90 per cent. is recoverable under the best actual conditions. Assuming for argument's sake that it were possible to obtain an amalgam extraction of 90 per cent. from a low grade ore, say 5 pennyweights, the low residue value (.5 pennyweight) would make the cyanide treatment altogether unnecessary. The argument which has been advanced that the free gold, not extracted by amalgam, is caught in the cyanide works, though borne out by assays of residues, is not conclusive. The maintenance of the accepted standard for residues, even with an enriched final pulp, is simply a matter of more or less thorough treatment and therefore of cost. The actual facts are, that neither the E. R. P. M. nor the Crown mines, with all their up-to-date and costly methods of treatment, have succeeded in raising the percentage of extraction by cyaniding much above the level of 85 per cent., which is easily obtained all over the Rand. The extraction of the E. R. P. M. in 1910 was 85.7 per cent., and on the Crown mines 88.3 per cent.

5. Metallurgical experts coming here from abroad should realize that, as far as these fields are concerned, grinding finer than the plus 200 mesh is mere waste of energy and money. The reduction of the last few percentages of the plus 60 grade by the tube milling cannot be done without the stern necessity of simultaneously grinding down the rest of the pulp. The great amount

of over-worked slime unnecessarily produced inevitably demands more perfect washing and dewatering equipment in the cyanide works, with consequent additional working costs and additional capital expenditure.

Working Costs.—Accounts and elaborate statistics, although admirably kept on all mines from a purely mathematical standpoint, fail entirely to give engineers any grasp of the true working costs of individual units of crushing equipment, or of the economic merits of innovations and improvements introduced. The variety of methods of accounting as practiced on different mines, and the more or less arbitrary entries of expenses in accounts where they do not belong, make it practically impossible to get at really significant figures. For instance (during the transition stage in 1909), the books of one of the amalgamated mines of the E. R. P. M. mines show an amount of £2,497 4s. 5d. under "sundries," whilst at the same time another mine of about the same size is debited with only £12 3s. under the same heading.

TABLE 4. REDUCTION COSTS PER TON, 1910

	Single-Stamp Crushing	Double-Stage Fine Grinding	
		New Kleinfontein Co. Output 1910: 466,882 tons	East Rand Proprietary Mines Output 1910: 2,126,334 tons
	Cents	Cents	Cents
Mining and development (excluded) ..			
Crushing, sorting, conveying.....	21.104		16
Stamp milling.....	41.560		33
Tube milling.....			14
Sand treatment.....	25.752		} 41
Slime treatment.....	6.812		
Total.....	95.228	123 2	104
General charges.....	16.220	12 4	37
Total reduction costs.....	111.448	135 6	141

Mining and development costs and the purely industrial reduction costs are fairly constant all over the Rand, depending exclusively on the economical efficiency of the reduction work and reduction management. There exists some diversity in the apportioning of the general charges, which in some mines are to a larger extent included in the various items of working costs, but the general result, which shows about 1s. per ton higher working costs for the "progressive" mines, can be taken as fairly representing the true position.

Capital Expenditure.—The ease with which money is forthcoming on the Rand for new innovations and inventions—if

TABLE 3. GOLD RECOVERY PER TON, 1910

	Single-Stamp Crushing				Double-Stage Fine Grinding														
	New Kleinfontein Co. 1,200 mesh				Myer & Charlton, 1905 400 mesh				East Rand Propr Mines				Crown Mines (Regrinding by Double-Stage Tube Milling)						
Grading	Per Cent.	Output, 1910: 466,882 tons Estimated ore reserves:	Re-cov-ered Penny-weights	Ex-tract Per Cent.	Grading	Per Cent.	Output, 1910: 2,126,334 tons Estimated ore reserves:	Re-cov-ered Penny-weights	Ex-tract Per Cent.	Grading	Per Cent.	Output, 1910: 13,950,277 tons; Pennyweights, 5.4	Re-cov-ered Penny-weights	Ex-tract Per Cent.	Grading	Per Cent.	Output, 1910: 1,514,000 tons Estimated ore reserves: 6,282,719 tons; Pennyweights, 7.6	Re-cov-ered Penny-weights	Ex-tract Per Cent.
+ 60	18	1,397,412 tons;			+ 60	33				+ 60	3	13,950,277 tons;			+ 60	5	6,282,719 tons;		
+ 90	22	Pennyweights, 6.45			+ 90	17				+ 90	10	Pennyweights, 5.4			+ 90	15	Pennyweights, 7.6		
+ 200	14				+ 200	14				+ 200	23				+ 200	12			
- 200	46				- 200	36				- 200	64				- 200	68			
		100					100					100					100		
Assay value of ore of Amalgam recover	7.063	4.454	63.06		10.869	4.867	55.22			7.008	3.512	3.512	50.11		8.37	5.71	5.71	68.2	
Assay value of final pulp Cyanide recovery.....	2.609	2.233	85.60		6.062	5.200	86.60			3.496	2.996	2.996	85.70		2.66	2.35	2.35	88.3	
Assay value of residue Total extraction.....	.376	6.687	94.50		.802	10.067	92.60			.500	6.508	6.508	92.85		.31	8.06	8.06	96.2	

boomed enough—is no inducement to responsible engineers to pay any more respect to the reservoir of “capital account” than that due to a waste-paper basket. In heralding the revolution which the “New Metallurgy” would bring about in Rand practice, in 1910 Doctor Caldecott said: “This capital expenditure is likewise reduced by the addition of such crushing units as tube mills at half the costs or less than the equivalent even in heavy stamps.” The metallurgical advisers of the E. R. P. M., faithful believers in the new gospel, made Sir George Farrar say at the March meeting, 1910, that they intended “to crush with 440 stamps more than we do now with the whole of our 820 stamps with consequently much decreased costs.” At the time when enthusiasm was at its highest, we were led to believe that we only needed to use coarse screens in the battery, and to buy so many tube mills, at so much a dozen, to reap the promised profits. By the irony of Providence, one year and a half later it was discovered that the capacity of the cyanide works at the E. R. P. mines was inadequate to deal with the increased proportion of slime, produced by the score of tube mills.

For technical purposes, the accountancy of an industrial concern may be carried out with one of two ends in view. It may give a clear insight into all details of working costs and capital expenditure, so as to enable those who desire true progress to judge new inventions and innovations on their economic merits. It may conceal blunders and failures. In either case, with very few exceptions, the annual reports give no details of the distribution of capital account and expenditure over the various units of the reduction plant. Consequently, the amount of money spent in forcing the “New Metallurgy” on the old plants cannot be even roughly estimated; but the figures in Table 5 are quite good enough to give an idea as to how far the promises of a reduction of capital expenditure “at half the costs or less” have been fulfilled.

In order to prevent any misunderstanding, I want to make it quite clear, that in emphasizing the better economic efficiency obtained with the older methods, I am far from advocating a policy of stubborn conservatism, or preaching a dogmatic and definite doctrine of single-stage stamp crushing. On the contrary, I think multiple stage crushing should be practiced in every rationally designed plant, so as to realize the advantages derived from intermediate classifiers. The use of tube mills, for the purpose of grinding, is not in question, but rather their abuse. The abuse consists in transferring to them that part of the crushing work which can be more efficiently done with stamps. It has been proved experimentally that the mechanical crushing efficiency increases with the coarseness of the battery mesh, and it appears that even a screen as coarse as 4 mesh is not the limit of highest efficiency. However, the advantage of a high amalgam extraction, got by double amalgamation, before and after tube milling, is so marked that to forfeit this advantage by crushing

so coarsely that the mill plates have to be discarded, is not advisable, unless the extraction in the cyanide works can be materially raised above the present level of 85-90 per cent. The use of fine battery meshes will, therefore, be advantageous, even at the cost of a possible loss in mechanical efficiency. With classifying well carried out, the suitability of the type of tube mills adopted as a standard on the Rand is doubtful. Other crushing machines may prove more efficient and should be given a trial. It is to be hoped that the tests of the “Hardinge conical mill,” now going on under the auspices of the Central Mining and Investment Co., at the Village Deep, will be more thorough and exhaustive than those of the Nissen stamp recently carried out by the same company. Mr. A. E. Crosse's regrinder (a drum revolving round a central axis with sliding mullers inside) also warrants testing and holds out promising prospects.

A great fuss was made when it became known that the New Kleinfontein Co. in deciding upon an increase of capacity of their reduction works, in order to deal with a further quantity of 10,000 tons per month (25 per cent. increase) had gone over to stage crushing. The methods adopted, on the advice of the consulting engineers—progressive in their conservatism—are, however, in no way a negation of their policy as hitherto practiced, but only a logical combination of both methods in perfect accordance with theory. Of the 220 stamps only 40 will be made responsible for the increase of output. These will crush through the very coarsest battery mesh, while the remaining 180 stamps will crush, as hitherto, through fine mesh screens. The underflow of the total pulp (run into classifiers of the type successfully adopted at the Benoni Consolidated) is to be reground by tube mills, which will work at a high efficiency, because the 40 coarse-crushing stamps will provide them with the right amount of coarse material to produce the most suitable mixed feed. A high amalgamation extraction will be secured by double amalgamation of the mill pulp produced by the 180 fine crushing stamps, before or after tube milling.

My remarks against the wisdom of the all-sliming policy refer exclusively to Rand ore and actual Rand practice, and may, under altered conditions, be reconsidered. At the Benoni Consolidated, for the first time on the Rand, combined sand and slime will be treated in agitation vats by the Way-Arbuckle process, and if the results of working on a large practical mining scale are up to expectation, the cyanide extraction will be so high and the costs so low, that all preparatory work must subordinate itself to the requirements of this part of the plant. Another case, in which all sliming may prove to be advantageous, is in adding free cyanide at the head of the tube mill. Mr. H. F. Marriot said in this connection (Bulletin I. M. M. No. 81, June, 1911): “It had been demonstrated satisfactorily to those responsible for their system, that the gold in the ore passed into solution so readily during its normal course through the tube mill, that there

TABLE 5. ROUGH ESTIMATE OF CAPITAL INVESTED IN STAMPS AND TUBE MILLS (Monthly Analysis of Chamber of Mines, December 31, 1910)

	Estimate of Cost Per Unit	Single Stamp Crushing (1,200 Mesh)		Double Stage Fine-Grinding			
		No. of Units at Work	Total Value	No. of Units at Work	Total Value	No. of Units at Work	Total Value
	£		£		£		£
Stamps (say 1,450 pounds) erected, including motor, ore bins, amalgam, plates, building, etc., complete.....	230	220 (Duty 5.9 tons)	50,600	820 (Duty 7.82 tons)	188,600	675 (Duty 7.6 tons)	155,250
Tube mills (22 ft. x 5 ft. 6 in.) erected, including complete tube mill circuit (motor, classifiers, pumps, launders, amalgam plates, etc.)	3,000			25	75,000	18	54,000
Total costs of stamps and tube mills.....			50,600		263,600		209,250
Ditto reduced to tonnage of Kleinfontein Mine.....			50,600		57,880		64,540

was not enough left undissolved to make it worth while to continue any subsequent treatment. This he (Mr. Marriot) believed had not yet been demonstrated on a practical scale on the Rand; but if it should prove only partially correct, and it were found possible to effect satisfactorily the rearrangement of solution circuits, it would eventually lead not only to a modification of our great cyanide plants, but probably to a tandem tube mill and the doing away with the cyanide plants altogether."

The investigation of this question was contemplated in connection with the Giesecke mill tests, but unfortunately, from commercial considerations, they were dropped, on the ground of the non-fulfilment of the expectations of mechanical efficiency.

The foregoing figures refer to tube mills and other expensive innovations. Filter tables, vacuum filters, etc., are in no way taken into consideration.

The bare facts, revealed by the annual reports of our largest producers, show that all this enormous capital expenditure, which has not even yet ended, has only increased reduction costs. The actual results, far from fulfilling those promised, fall short even of those obtained five years ago, if due allowance is made for the progress attained in directions which have no direct connection with the "New Metallurgy." The figures, published in Messrs. Denny's paper on the extraction percentages obtained at that time on mines of the Central Rand, with battery pulps as coarse as 400 mesh, leave no room to doubt that the E. R. P. mines could at once reduce their reduction costs considerably by simply returning to the sounder economical methods of the older days. There is no earthly reason to prevent this mine and the Crown mines reaching an economical efficiency equal to that of the New Kleinfontein mine, which is run on old-fashioned lines without any tube mills at all. The much-abused excuse that the different nature of the ore is responsible for the poor results obtained is hardly borne out by the records filed at the reduction offices, and if any considerable prejudicial effect of this kind were proved it would yet be more than balanced by the advantage of the enormously larger tonnage dealt with.

In face of this array of facts, it would be highly interesting if Doctor Caldecott or Mr. F. L. Bosqui, the most prominent exponents of the new school, would tell us why we should not go back a few years, and, with the experience now at our disposal, make "a fresh start" on the sound basis of actual knowledge gained by the eminently useful research work carried out by the Mines Trials Committee.

The consulting engineers of the big mining houses are said to be too busy to find time for the public discussion of technical problems. Now, in the present state of affairs, they owe it to their professional honor, and to the dignity of the highly responsible positions which they occupy, to break their silence, and, before enormous sums are again buried in inefficient plants, give proofs and facts in justification of the policy adopted.

采 采

Use of Candles in the Transvaal

According to the statistics furnished by the Transvaal mines department the gold, diamond, and other mines of the Transvaal consumed candles to the value of \$1,186,798 during the calendar year 1909, and for the fiscal year ended June 30, 1910, the consumption amounted in value to \$1,171,947.

During 1910 paraffin wax entering into the manufacture of candles was imported into South Africa to the extent of 20,992,412 pounds, an increase of 4,718,413 pounds over the preceding year. Steam, amounting to 2,757,676 pounds in 1909 and 2,978,979 pounds in 1910, was also imported for conversion into candles. Of the 1910 imports the United States supplied 13,648,883 pounds of the paraffin wax and 220 pounds of the stearin.

Most of the machinery and equipment used in the manufacture of candles in South Africa is understood to be the product of America.

Catalogs Received

- WAGNER ELECTRIC MFG. CO., St. Louis, Mo., Calendar.
 ALLIS-CHALMERS CO., Milwaukee, Wis., Pulverator, 8 pages.
 SHEAR-KLEAN GRATE CO., Chicago, Ill., Save Coal, 12 pages.
 TRILL INDICATOR CO., Corry, Pa., Trill Indicators, 47 pages.
 CARNEGIE STEEL CO., Pittsburg, Pa., Structural Beams, 12 pages.
 STURTEVANT MILL CO., Boston, Mass., Sturtevant Crushers, 16 pages.
 THE SYLVESTER CO., Connellsville, Pa., The "Sylat" Timber Puller, 12 pages.
 HAZARD MFG. CO., Wilkes-Barre, Pa., Hazard Hand Forged Wire Rope Fittings, 24 pages.
 THE LAGONDA MFG. COMPANY, Springfield, Ohio, The New Lagonda Air Cleaner, 4 pages.
 INGERSOLL-RAND CO., 11 Broadway, New York, N. Y., Jack-hamer, Type BCR-43, 12 pages.
 THE LÜNKENHEIMER CO., Cincinnati, Ohio, 1912 Illustrated Catalog and Price List, 654 pages.
 STROMBERG-CARLSON TELEPHONE MFG. CO., Rochester, N. Y., Private Telephone Systems, 24 pages.
 THE GOULDS MFG. CO., Seneca Falls, N. Y., Bulletin No. 112, Handy Data on Power Pumping, 16 pages.
 CHICAGO PNEUMATIC TOOL CO., Chicago, Ill., "Chicago Pneumatic" Compressors for Air and Gas, 12 pages.
 F. M. WILLIAMS, Watertown, N. Y., Modern Methods and Apparatus for Industrial Gas Analysis, 12 pages.
 JOHN A. ROEBLING'S SONS CO., Trenton, N. J., 4-page folder, The Manhattan Bridge, showing tests of wire used therein.
 THE BRISTOL CO., Waterbury, Conn., Catalog No. 1000, Bristol's Recording Gauges for Pressure and Vacuum, 64 pages.
 TAYLOR IRON & STEEL CO., High Bridge, N. J., Bulletin No. 114, Tisco Manganese Steel Crusher and Pulverizer Parts, 4 pages.
 LINK-BELT CO., Philadelphia, Pa., "Link-Belt" Locomotive Cranes, 32 pages; Ewart Friction Clutch, "The Safe Clutch," 18 pages.
 HYATT ROLLER BEARING CO., Newark, N. J., Section No. 604E, Hyatt Roller Bearings as Applied to Mine and Industrial Cars, 24 pages.
 MCKIERNAN-TERRY DRILL CO., 115 Broadway, New York, N. Y., Heavy Duty Pile Hammers, 8 pages; "Wizard" Rock Drills, 12 pages.
 THE DEANE STEAM PUMP CO., 115 Broadway, New York, N. Y., Horizontal Duplex Piston Pumps Operated by Direct-Connected Vertical Gasoline Engines, 4 pages.
 SULLIVAN MACHINERY CO., Chicago, Ill., Bulletin No. 58K, Sullivan Duplex Air Compressors, 16 pages; Bulletin No. 58L, Sullivan Air Compressor Accessories, Useful Compressed Air Data, 40 pages; Bulletin No. 66-F, The Sullivan "Lightweight" Rock Drill, 12 pages.
 AMERICAN BLOWER CO., Detroit, Mich., A Big Factor in Power Plant Economy, 8 pages; Sirocco Standard Ventilating Sets, Cast-Iron Volume Blowers and Exhausters, 20 pages; Bulletin No. 334, "A B C" Vertical Self-Oiling Engines, 52 pages; Bulletin No. 337, "A B C" Twin Variable Speed Steam Engines for Driving Paper Making Machines, 16 pages; Bulletin No. 340, Sirocco Fans and Blowers, 48 pages; Bulletin No. 344, "A B C" Cast-Iron Blowers and Exhaust Fans, 4 pages.
 GENERAL ELECTRIC CO., Schenectady, N. Y., Bulletin No. 4910, Oil Break Switches for 600-, 4,500- and 7,500-Volt Alternating Current Service, 12 pages; Bulletin No. 4922, Electricity in Metal Mines, 40 pages; Bulletin No. 4938, Type "H" Transformers, 14 pages; Bulletin No. 4939, Electric Hoists, 16 pages; Bulletin No. 4940, Type DLC Commutating Pole Motors, 8 pages; Bulletin No. 4941, The G-E Water-Flow Meters, 16 pages; Bulletin No. 4949, Direct-Current Portable Instruments, Type DP-2, 8 pages.

Timbering a Small Shaft

A Rapid and Efficient Method of Timbering Suited to Small Shafts or Those for Temporary Use

By John T. Fuller*

The method of shaft timbering herein described was devised and put in use by the writer under the following circumstances:

At a certain mine an inside shaft had been sunk to a depth of 360 feet for the purpose of developing a block of ore. A station had been cut and a short section of tunnel driven on the 360-foot level. A station had also, of course, been cut at the top level. The shaft was about 10 ft. 6 in. x 7 ft. in the clear, and was sunk by hand, using a bucket with rope guides and an air hoist.

The upper part of the shaft was in a strong "quartz porphyry" and the last 100 feet or so in a hard, compact quartzite. The sides of the shaft, therefore, were in good strong rock all the way and required no support.

After the work indicated above had been completed, for some reason unknown to the writer the shaft was abandoned and allowed to fill with water. The hoist, head-frame, etc., were dismantled and removed.

When the writer took over the management, the mine was in a serious condition, development being but a few months in advance of the mill. It was imperative to develop the block of ore opened by this shaft with the greatest possible speed.

Electric sinking pumps were immediately put to work unwatering the shaft, an electric hoist was installed, and a head-frame erected.

This work required about eight days and would have taken less time if it had not been for almost continuous pump troubles.

In the meantime the timbering method was "thought out" and detail drawings prepared.

The work of cutting and framing these timbers, steel plates, etc., was rushed through the shops and the first consignment delivered at the shaft on the day the water was pumped out. The entire consignment as per bill of material (Table 1) was completed the next day.

TABLE 1

Bill of Material for 360' Shaft

No. Pieces	Mark	Dimension	Description
120	①	9" x 3" x 10'	Wall plates, cut as shown
240	②	9" x 3" x 5' 3"	Studdles, plain
120	③	9" x 3" x 5' 4"	Dividers, plain
120	④	9" x 3" x 5' 4"	End plates, plain
162 sq. ft.	⑤	2"	Flooring, X or L. W.
72	⑥	9" x 3" x 3' 2"	Joists, X or L. W.
1,890 sq. ft.	⑦	1"	Lagging
18	⑧	24"	Ladders
52	⑨	4 1/2" x 3" x 30'	Guides, square ends
240	⑩	18" x 9" x 1/4"	Studdle plates, S or W. I.
450	⑪	18" x 9" x 1/4"	Divider and end plates, S or W. I.
36	⑫	4 1/2" x 3" x 4'	Guide joints

Timber to be wedged at corners and behind dividers
 100 1/2 x 6" bolts, guide joints
 50 1/2 x 8" bolts, guide joints
 1,440 1/2 x 4" bolts, studdle plates
 3,840 1/2 x 4" bolts, end and divider plates

The placing of the timbering in the shaft, installing a permanent pump at 360-foot level, and the complete equipment of the shaft for all purposes required 11 days, or 33 shifts.

The conditions governing the design of the timbering were, first, the strong rock sides of the shaft; second, the very high cost of timber in that locality; and third, the urgency of getting the shaft into operation in the shortest possible time.

It was decided to discard the usual square set method of timbering with its complicated framing, as being too slow, expen-

sive, and more permanent than the ultimate use of the shaft would justify.

The details of the method of timbering decided on are clearly shown in Fig. 1.

All timbers are 9 in. x 3 in. in cross-section, all plates of 1/4-inch wrought iron or steel, and all bolts 1/2-inch diameter with square heads.

The "wall plates" are 10 feet long with 1/2-inch checks cut in each end to receive the "end plates," and similar checks for the

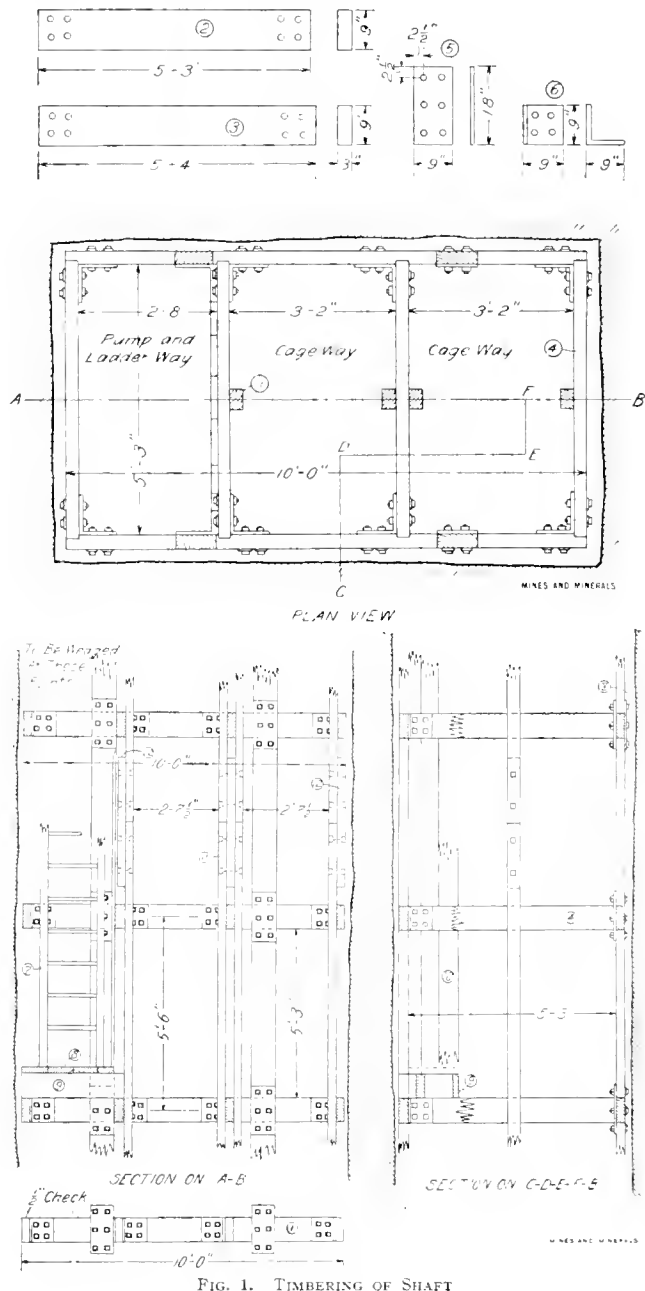

FIG. 1. TIMBERING OF SHAFT

two dividers. These four checks in each "wall plate" are the only actual framing in the whole system, and were provided simply to preserve the alinement. The checks could, I believe, be eliminated entirely without danger in shafts of this class.

The "end plates" and "dividers" are 5 feet 4 inches long and absolutely plain with the exception of the holes bored to receive the bolts.

The "posts," or "studdles," are 5 feet 3 inches long, also plain, with the exception of the bolt holes. All joints are practically plain butt joints, the stability and necessary rigidity being provided by the steel plates.

* Consulting Engineer.

The plates both for the "posts" and corners, cut from $\frac{1}{4}$ -inch material, are 9 in. \times 18 in. over all, drilled to receive $\frac{1}{2}$ -inch bolts as shown.

The pump and ladder compartment is divided off from the cage compartments by 1-inch plank nailed to the dividers. The ladders used are 24 feet long with steel rungs in wooden frames. The line of ladders is broken every 18 feet by platforms as shown.

The novelty in the method lies in the use of the plate joints and the use of only four posts, instead of eight, as would be the case in a three-compartment shaft, if timbered by the ordinary methods.

The method lends itself equally well to timbering from the bottom up or from the top down. In the latter case no hanging bolts are required, as the plates serve the same purpose.

The method of procedure in timbering the shaft in question was to first place the "collar set" and hang one "set" below it.

The cage guide and ladderway were carried up simultaneously with the timbering.

In the shaft in question, washers were used behind each bolt; but if greater strength and stability are required two plates may be used as indicated at X (Fig. 1).

While the timbering as described is more particularly adapted for small shafts with good sides, it can be used successfully for larger shafts with fairly bad sides by cutting down the distance between sets, or lagging behind the sets, or both.

The plate method can be used with larger timbers than 9 in. \times 3 in. by increasing the size and weight of the plates and bolts proportionally.

In shafts much larger than the one described, however, it would hardly be advisable to use timbers as light as 9 in. \times 3 in., even with good strong sides, owing to the liability of distortion.

In shafts from 10 ft. \times 7 ft. down, however, where the timbering is required to do practically nothing but act as a support

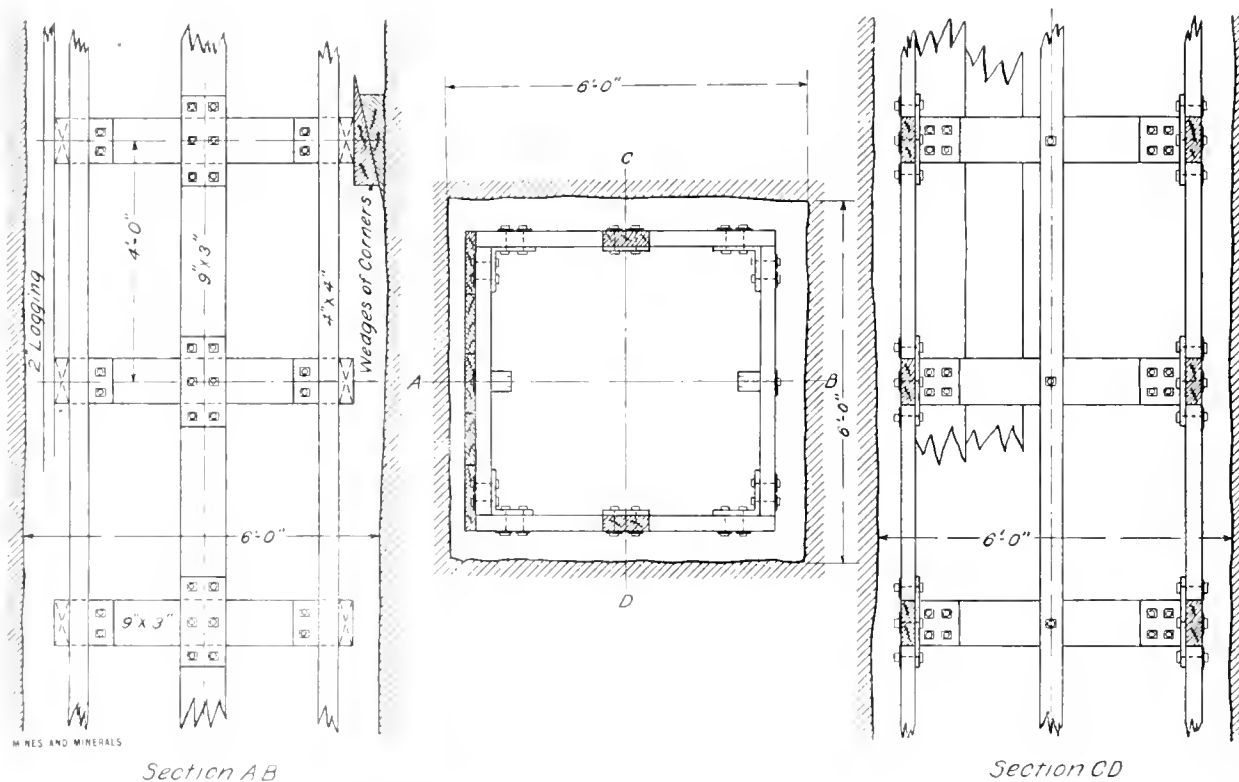

FIG. 2. METHOD OF TIMBERING FOR SMALL SINGLE COMPARTMENT SHAFT

These sets were used as guide sets from which the plumb lines were hung. The timbering was then started from the bottom of the shaft by first placing four 6" \times 9" timbers secured by hitches cut in the sides of the shaft just below the 360-foot level. The bottom set rested on these timbers with the top edge of same just even with the 360-foot level. This set was carefully adjusted to line and securely blocked in position. The main timbering of the shaft was then built up rapidly much like the erection of a steel frame for a building; in fact, the writer had this idea in mind when designing the timbering.

The men worked on temporary platforms, of 2-inch plank slung across the completed sets, which were easily shifted up from set to set as the work progressed.

The "end plates," "posts," and "dividers" of a set were sent down in the bucket first. Then the two "wall plates," with the steel plates already bolted in place, were lowered and quickly bolted in place on top of the "posts," which had in the meantime been bolted to the set next below. As quickly as three successive sets had been thus connected, they were carefully tested with the lines and blocked in place.

for the guides, pump column, and ladderways, this light timbering is economical and amply strong.

In the shaft described, very little of the weight of the 4-inch column pipe came directly on the timbering, as it was supported on a pedestal block at the bottom and a special clamp at the top.

This method of shaft timbering should find a place (if indeed it has not already done so) in contracting work, where it is often necessary to sink and timber small temporary shafts, which are either later entirely abandoned, or put to such use as requires no permanent timbering; for it is a comparatively simple matter to withdraw the timbers for use elsewhere.

In fact, for temporary timbering of this nature it would not be necessary to cut any checks in the "wall plates," which would make it a simple matter to increase or decrease the size of the compartments to suit the requirements of the case.

In Fig. 2 is shown a method of timbering for a small single-compartment prospect shaft such as is frequently required in mining work, especially in the early development of a mine. This method requires but two "posts" per set, may be made of even lighter timbers than 9 in. \times 3 in., is easily put together, and, above

all, is easy to transport over rough country, which is often a very important item.

As this method is practically the same as the first, and the details are plainly shown in Fig. 2, no further description is necessary.

The writer has no doubt but that methods like, or similar to, the one described have been used by others in other fields, but not to his knowledge or observation.



Prevention of Miners' Phthisis

The Royal Commission of New Zealand, in its report, states that, from the evidence taken by it, it is apparent that tuberculosis has not in New Zealand assumed such proportions as indicated

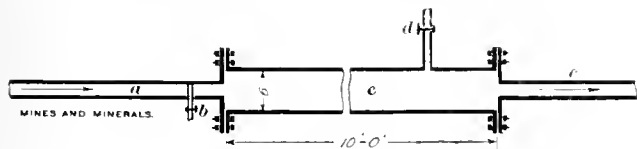

FIG. 1. JAMES WATER BLAST

by the returns from Cornwall, Bendigo, Queensland, West Australia, and the Transvaal. In proof to the same effect it should be stated that during the period between October 10, 1908, and December 24, 1909, when pneumoconiosis (a term which formerly was used to classify a group of diseases all similar in character, amongst which miners' phthisis is included) was a disease, in contracting which a miner was entitled to compensation under the Workers' Compensation Act, not a single claim was made for compensation in respect of the disease.

The preventive measures considered by the Commission, and which have been generally recommended by other Royal Commissions elsewhere, are as follows:

1. The compulsory use of dust-preventing appliances, such as sprays, water blasts, and atomizers.
2. Improved ventilation of mines.
3. Use of bath and change houses at the mines.
4. Prevention of indiscriminate spitting, and the destruction of tuberculous sputum.
5. Definite treatment of those affected with tuberculosis of the lungs in an advanced form.
6. Improved housing conditions and disinfection of work places and living quarters.
7. The exclusion from work underground of all persons infected with tuberculosis of the lungs.

The use of dust-preventing appliances is provided for under Section 19(m) of the Mining Act Amendment Act, 1910, viz.:

"There shall at all times be used in and about the battery or place where such crushing or drilling is done an adequate jet or spray of water, or such other appliances as in the opinion of the inspector will effectually keep the air pure and prevent dust circulating in the place where such operations are being carried out, and for this purpose an adequate supply of water shall be provided."

In addition to which it would be advisable that an approved water blast be used immediately after blasting in mines, a provision made compulsory in Transvaal for the purpose of allaying the noxious gases, smoke, and dust, caused by blasting in close ends. The use of a water blast of the James type is recommended by the Transvaal Royal Commission, and is thus described in Doctor Haldane's "Report on the Health of Cornish Miners":

"At the mouth of the level a piece of 6-inch iron pipe *c*, Fig. 1, or a small cylinder, provided with a side tap *d* is let into the ordinary 2-inch iron pipe *a* for carrying the compressed air for the drill. Before the blast this is filled with water through the side tap from a cistern after the compressed air has been turned

off. Immediately after the blast the compressed air is suddenly turned full on. The water is thus driven along the pipe *e* with great velocity, and a mixture of finely divided water and air is discharged from the open end, which is directed toward the face which has just been blasted. By this means the dust is entirely cleared from the last 30 feet or 40 feet back from the blast, the air leaving quite clear immediately after. If a ventilating pipe as shown in Fig. 2 is carried forward about as far as the compressed air pipe, any dust which has been driven out beyond the reach of the jet can be rapidly carried off. This plan has the great merit that it implies scarcely any trouble, and no extra apparatus except the piece of 6-inch pipe and tap for filling it. The rock blasted is also thoroughly wetted, so that no dust is produced in shoveling it. The water partly washes out from the air any nitrous fumes which may be present, but, of course, no carbonic oxide, and for this reason, if no other, a ventilating pipe is desirable in cases where the level or rise has been driven more than a few fathoms beyond the air current."

The ventilating apparatus shown in Fig. 2 consists of a pipe *b*, in which is inserted a reversible nozzle *a* connected at the valve *c* to the compressed air pipe *d*. By adjusting the nozzle *a* and admitting compressed air, a current may be induced in either direction through the ventilating pipe *b*.

The more adequate ventilation of all mines to a standard of quality, quantity, and fixed temperature, is dealt with under the heading of "Ventilation."

The use of bath and change houses is also recommended.

The prevention of indiscriminate spitting appears to be a matter requiring urgent attention by local bodies and by the government. The dissemination of directions regarding the destruction of tuberculous sputum is very necessary.

Improved housing conditions for miners and the definite treatment of tuberculous persons are matters which are being strongly advocated by many medical practitioners of New Zealand.

The exclusion from work underground of persons infected with tuberculosis of the lungs is a matter insisted upon by all authorities.

The Commission therefore makes the following recommendations:



FIG. 2. VENTILATING APPARATUS

Preventive Measures.—Every working place where rock drills are in use shall be furnished with an approved water blast or suitable appliance for laying the dust, smoke, and gases after a blast; and no man shall return to an end, rise, winze, or other close place, until the air is free from dust, smoke, and fumes, caused by blasting.

Measures of Relief.—That miners suffering, or suspected to be suffering, from fibrosis or superimposed tuberculosis of the lungs shall have free medical advice from the government, such advice to be given by a medical expert appointed for the purpose.

That in addition to the homes and sanatoria already established, adequate relief be provided from the Gold Miners' Relief Fund for those suffering from miners' phthisis, which for that purpose shall be subsidized £1 for £1 by the government.

The qualifications for the above measures of relief to be 5 years' residence in New Zealand immediately prior to the application for relief, 2½ years of which shall have been occupied in mining underground or working at a crushing mill in New Zealand.



Bismuth Alloy

A very fusible alloy is made of 1 part bismuth, 1 part tin, 1 part lead; this fuses below 212° F.

The Occurrence of Tin

A Description of the Formations in New South Wales. Mineralogy of Tin

The following is an abstract from "The Tin Mining Industry and the Distribution of Tin Ores in New South Wales," by J. E. Carne, F. G. S., Assistant Government Geologist.

It will be noticed that in all cases tin deposits occur concentrated in districts connected with granite masses or their metamorphic contact zones, but this position is generally further characterized by the presence of post-granitic dikes of quartz porphyry (Elvan), which, like the lodes, have directions similar to that of the cleavage of the sedimentary rocks which they traverse. As a whole, the tin ores appear to represent the final phase of plutonic activity in the region, the sequence of events being: (1) Intrusion of the granite masses with thermal metamorphism of the slates surrounding them; (2) intrusion of quartz porphyry; (3) formation of tin and copper lodes accompanied by extensive mineralization of both sedimentary and igneous rocks.

The tin and copper lodes as a whole may be described as fissures of varying size and form, which contain a variety of ores of tin, copper, and other metalliferous minerals, together with characteristic veinstone accompaniments.

The structure of the lodes indicates to some extent their mode of origin; and while some of them are mere joints or cracks of the thickness of a knife blade, others are wide and contain much fragmental crushed material, indicating that they are probably of the nature of faults.

The variety of structures which the veinstones may assume under such circumstances is fully represented in Cornwall, and as a whole may be classified into one or more of the following groups:

- (1) Fissure, or series of close parallel fissures, filled with metalliferous and other minerals.
- (2) Mineralization of the walls of the lodes by impregnation or metasomatic replacement.
- (3) Mineralization of crushed rock or breccias contained in the lode.*

Leaving out of consideration alluvial deposits, the mode of occurrence of which is obvious, tin ore occurs in granite and adjacent contact rocks, usually occupying fissures, frequently penetrating the wall rocks, and sometimes disseminated in the granitic host.

The forms which the ore bodies take have been variously called lodes, reefs, veins, pipes, stockworks, etc. The first three are interchangeable, but as the original definition of a defined fissure filling is "lode," it has been adopted in this work. "Reef" is chiefly an Australian term, originally applied—according to Geikie—to an outcrop standing above the surface. It is also used to define the rock walls confining an old buried channel or "deep lead."

"Shoot" is the ore bearing portion, or portions, in a lode channel. David in describing those of the Vegetable Creek district, states:

"The ore, in nearly all the veins of this district, shows a tendency to run in shoots inclined more or less steeply from the horizontal obliquely along the plane of the lode. The average length of the six largest shoots is 100 feet."

SUMMARY OF TIN VEINS†

The following provisional classification, based on the foregoing observations, is proposed for the tin veins of the Vegetable Creek district:

- I. True veins, comprising: 1. Fissure veins; example, "Ottery veins." 2. Joint veins; example, "Cliff vein." Both

these subdivisions may be further differentiated according as the veins to which they apply are right running or marginal, the right running veins being those which conform to the principal system of cracks in the granite, while the strike of the marginal veins accords closely with that of the junction line of the claystone and granite.

II. Pipe veins, "impregnations" or "carbonas"; example, "Graney's vein."

III. Stockworks: 1. Formed by lateral secretion (?) from the surrounding rock; example, stockwork at "Gap," Ennerville. 2. Formed by ascension and infiltration; example, stockwork at "Hall's Grampians."

These three classes cannot, in practice, be always separated from one another by a hard and fast line.

Joint veins with shoots of ore at intervals graduate into pipe veins; a fissure vein, by a change of strike, becomes a joint vein; and both, if they pass into a hard quartzose granite, are liable to become split up into a stockwork composed of numerous thread-like veins.

In the Vegetable Creek, as in other mining districts, experience has proved that it does not pay to remove the whole of the veinstone, but only those parts of it in which the ore has become sufficiently concentrated to pay the cost of extraction. Any laws with regard to the occurrences of such parts should, therefore, be of paramount importance in an inquiry like the present.

The ore, in nearly all the tin veins of this district, shows a tendency to run in shoots inclined more or less steeply from the horizontal obliquely along the plane of the lode. In fifteen cases this characteristic was very marked.

The average length of the six largest shoots is 100 feet; average width of the six largest shoots, 1½ feet; average depth of seven largest shoots, 6 feet; average dip, 26 degrees; average horizontal distances between shoots, about 80 yards; vertical distances (observed only at Gulf tin mines), 50 to 90 feet. Eleven shoots were observed to dip northeasterly; two shoots were observed to dip southwesterly.

Some idea of the size of the shoots may be formed from the description of eleven of these ore bodies given in Table I.

TABLE I

Length, in Feet	Depth, in Feet	Thickness, in Feet	Angle of Dip Degrees
55	4½	¾	20
127	15	3 ¾	12
	1½	¾	
	3	1 ¾	
7	1	¾	
30	4	1½	37
	½		
	4	½	19
125			19
150			45
120	15	½	20

In veins in which the "shoot" structure is less marked, the ore is either more or less disseminated through the mass of the veinstone, or occurs in "floors," occupying the position of former transverse cracks, which cross the vein at right angles to its dip. The ore usually favors the hanging wall.

The following appear to have most influence on the metalliferous character of these veins: (1) Country rock; (2) bearing of the veins, and relation of its bearing to that of joints in the country rock; (3) amount of dip; (4) associated minerals; (5) development of walls.

INFLUENCE OF COUNTRY ROCK ON THE METALLIFEROUS CHARACTER OF VEINS

76 veins are enclosed in granite.

8 veins are enclosed in quartz-porphyry and auriferous.

3 veins are enclosed in porphyroid.

3 veins are enclosed in claystone.

* Economic Geology, 111, No. 5, 1908, page 369.

† Geol. Veg. Ck., 1887, pages 144-148.

A fine-grained hard quartzose granite is unfavorable, causing the veins to be narrow, and in some cases to become split up into a number of thin seams, as in the "Gulf" group of veins, and the stockwork at Battery Mountain.

Fine-grained schorlaceous granite seems equally unfavorable, as evidenced by Macdonald's lodes on the Glen Creek, where veins of tinstone and tourmaline, from 1 inch to 2 inches wide, show no appreciable alteration in thickness in a vertical extent of 200 feet.

Porphyrite granite, with large, well-formed white crystals of feldspar, is also prejudicial, as in the neighborhood of the Haystack Mountain, where the quartz veins, as a rule, are not tin bearing.

The most favorable granite appears to be that in the neighborhood of the Dutchman mines. The rock in that locality is moderately hard, and may be described as an open-grained ternary granite, containing rather large greenish crystals of feldspar, not sharply defined at the edges, but merging gradually into a more finely crystalline mass of feldspar, quartz, and mica. Patches and bands of more coarsely crystalline rock are intermixed with the more finely crystalline, and geodes of feldspar are not uncommon.

Eurite dikes intersecting the coarse granite are also favorable.

If the country rock be quartz-porphry, or eurite, the fairly soft, strongly cleaved feldspathic varieties, with a greenish tinge due to the presence of chlorite or hornblende, are more favorable than those which are hard, less cleaved, quartzose, and white.

Out of seventy-seven veins in which tinstone has been proved to occur, nineteen consisted of quartz and tinstone only, eight of tinstone and feldspar only. The relative frequency of occurrence and kind of minerals, associated in the veins with tinstone, is given in Table 2.

TABLE 2. TIN VEINS AND ASSOCIATED MINERALS

69 veins contain quartz.
29 veins contain chlorite.
20 veins contain feldspar.
8 veins contain mica.
8 veins contain mispickel.
4 veins contain iron pyrites.
4 veins contain fluor spar.
3 veins contain tourmaline and schorl.
3 veins contain wolfram.
2 veins contain blende.
2 veins contain galena.
2 veins contain copper pyrites.
2 veins contain bismuth.
2 veins contain molybdenite.
2 veins contain vesuvianite.
2 veins contain stilbite.
1 vein contains hematite.
1 vein contains manganese.
1 vein contains scheelite.
1 vein contains beryl.

Well-defined walls were observed in fourteen cases, generally showing slickensides. The foot-wall is usually cleaner and better defined than the hanging wall. The best veins in the district have good walls. Where walls are absent, their place is taken by a central crack traversing the veins, the vein stuff on either side passing very gradually into granite.

Apart from considerations of cost of labor and carriage, two conditions which most directly affect the value of a vein are (1) size of vein; (2) proportion of ore contained in the vein to the veinstone.

1. Size: (a) Length.—The greatest length for which a vein has been observed by me to be tin bearing is 1 mile. This is Butler's vein. The Wallaroo vein will also, probably, be found to be tin bearing for an equal length.

(b) Width.—The average width of 69 veins is 1 foot $6\frac{3}{4}$ inches. The following are the thicknesses of six of the largest veins now being worked: (1) Ottery vein, 3 feet; (2) Ottery vein, 4 feet; Butler's vein, 3 feet 2 inches; (1) Dutchman vein, 4 feet; (2) Dutchman vein, 3 feet; Curnow's vein, 3 feet.

The following gives the mineralogy of tin:

Cassiterite (tinstone).—Description (Dana): Crystallization, tetragonal. Cleavage, imperfect; luster, adamantine; crys-

tals, usually splendid; color, brown or black, sometimes red, gray, white, or yellow; streak, white, grayish, brownish; nearly transparent to opaque.

Composition: Tin dioxide, SnO_2 = oxygen 21.4; tin, 78.6. Before blowpipe alone, unaltered; on charcoal with soda, reduced to metallic tin, and gives a white coating. With the fluxes, sometimes gives reactions for iron and manganese. Only slightly acted upon by acids.

Stannite (Dana).—Massive, granular, and disseminated; cleavage, cubic, indistinct; fracture, uneven; brittle; luster, metallic; streak, blackish; color, steel-gray to iron-black, the former when pure; sometimes a bluish tarnish; often yellowish from the presence of chalcopryite; opaque.

Composition: A sulphide of tin, copper, iron, and sometimes zinc; perhaps Cu_2S , FeS , SnS_2 = sulphur, 29.9; tin, 27.5; copper, 29.5; iron, 13.1.

In closed tube, decrepitates, and gives a faint sublimate; in the open tube, sulphurous fumes; before blowpipe on charcoal, fuses to a globule, which in oxidizing flame gives off sulphur and coats the charcoal with tin dioxide; the roasted mineral treated with borax gives reactions for iron and copper.

Decomposed by nitric acid, affording a blue solution, with separation of sulphur and tin dioxide.

Until the discovery of stannite in considerable quantity at Howell, New South Wales, and Zeehan, in Tasmania, this ore was too rare to have any commercial value. Attempts to treat it metallurgically at Howell, have so far not been altogether successful, owing to the complexity of its associates, viz., lead, copper, iron, arsenic, silver.

Considerable interest centered in the recent efforts in that direction at the Conah mine, Zeehan, Tasmania, where a very similar mixture of minerals occurs, with the addition of antimony and bismuth.

At Tolwong, in the Shoalhaven River Valley, near Bungonia, stannite occurs in lenses of ore in a very permanent lode fissure; here it is associated with arsenic, chalcopryite, and a little galena, but with a lesser amount of silver. This recent discovery is now being opened up, and the results of treatment are also awaited with interest.

S. Fawns points out that tin "is the rarest of the common metals of commerce, and is produced in markedly smaller quantities. Unlike most of these metals, it is distributed sparingly throughout the world, occurring in workable amounts at but few localities; where it does occur, however, it is generally, but not invariably, found in very important quantities. (The exceptions seem to be mostly in the United States.—EDITOR.)

"Again, tin is the only common metal, except iron, the only true ore of which consists of an oxide of the metal. All other metals appear to have been deposited originally as sulphides, their existence in the oxidized state being due to the secondary action of atmospheric agencies upon these sulphides. Hence, the other metals are found as oxides near the outcrops only of their deposits, but as sulphides in depths; whilst tin appears as an oxide wherever it has hitherto been found, even in the deepest mines in which it has been met with, and at depths, where all other metals are known as sulphides."*

The same authority points out the indifference of tin oxide to weathering as follows:

"The sulphides of the other ordinary metals, when exposed to atmospheric agencies form more or less soluble compounds; oxide of tin is notable for its great chemical indifference and for its insolubility in those reagents that dissolve most other metallic compounds. Hence, the degradation of a mineral deposit containing any of the other metals is apt to be accompanied by the removal in a state of solution of those other metals. In the case of tin it will only lead to a concentration and purification of the oxide. This is why oxide of tin (the tinstone or black-tin of the miner, and cassiterite of the mineralogist) is found to so large

* Tin Deposits of the World, second edition, 1907, page 6.

an extent in alluvial grounds, a mode of occurrence that it shares almost exclusively amongst metallic minerals with those other chemically indifferent substances, gold, tungsten, and platinum."

Cynfeldite.†—Composition: Sulphur, 16.22; tin, 6.94; germanium, 1.82; silver, 74.10; iron and zinc, .21. Isometric, perhaps tetrahedral, crystallization. Fracture, uneven to small conchoidal. Brittle; hardness, 2.5-3. Specific gravity, 6.276. Luster, metallic, brilliant. Color, black with bluish tint.

Before blowpipe, fuses at 2 on charcoal, yielding a coating of the mixed oxides of tin and germanium, white or grayish near the assay, tinged with yellow on the edges. By long blowing a globule of silver covered by tin oxide is obtained. In the closed tube, sulphur is given off, and at a high temperature a slight deposit of germanium sulphide.—*Dana*.

Cylindrite.‡—Composition: Sulphur, 24.50; tin, 26.37; antimony, 8.73; lead, 35.41; silver, .62; iron, 3 = 98.63. Massive; in cylindrical forms separating under pressure into distinct shells or folia, difficult to pulverize, like graphite. Soft; hardness, 2.5-3. Specific gravity, 5.42. Luster, metallic. Color, blackish lead-gray. Streak, black.—*Dana*.

Franckite.§—Composition: Sulphur, 21.04; antimony, 10.51; tin, 12.34; lead, 50.57; iron, 2.48; zinc, 1.22; gangue, .71 = 98.87.

Massive, with imperfect radiated and foliated structure; in part in spherules aggregated in reniform shape. Cleavage perfect in one direction. Somewhat malleable, making a mark on paper. Hardness, 2.75; gravity, 5.55; luster, metallic; color, blackish-gray to black. Opaque.

Germanium is present in small amount (.1 per cent.); also about 1 per cent. silver.

Before blowpipe on charcoal gives a yellow coating of lead oxide, and further from the assay one of oxide of antimony. In the open tube, yields sulphur and antimony fumes; in the closed tube, a slight coating of germanium sulphide, if no air is present. Dissolved by nitric acid with the separation of a white powder (oxides of antimony, tin, and germanium); also readily in aqua regia with separation of sulphur.—*Dana*.

Stokesite.||—Composition: Analyses of a minute quantity gave: Silica, 43.1; tin oxide, 33.3; calcium oxide, 13.45; water, 8.6.

Known only in a single crystal of acute pyramidal habit. Cleavage, imperfect. Fracture conchoidal. Brittle; hardness, 6; gravity, 3.185. Luster, vitreous. Colorless, transparent.—*Dana*.

Tealite.¶—Composition (*Dana*): Sulphur, 16.29; tin, 30.39; lead, 52.98; iron, .20 = 99.86.

Yields a little sulphur in the closed tube, but does not fuse; readily decomposed by hot hydrochloric or nitric acid.

Occurs in thin folia, resembling graphite, embedded in kaolin, upon a dark gray matrix impregnated with pyrite; also associated with wurtzite and with galena.

Cleavage, perfect. Hardness, 1-2; gravity, 6.36. Luster, metallic. Color, blackish gray. Streak, black. Opaque.

采 采

Holding Leases Without Operating

Through the courts, an attempt is being made by Audrey Young, of Iron River, Mich., to compel the Verona Mining Co. to either operate or surrender an 80-acre tract of land owned by him and held by the company under lease. The land, which a joint the company's Baltic mine on the north, was explored by the defendant eight years ago at a cost of \$20,000, and while little ore was shown, it was decided to lease the property for the reason that the ore in the Baltic mine apparently extended into this property. The lease signed by Mr. Young provided for a royalty of 10 cents a ton for all ore mined and a minimum royalty

of \$1,000 a year, the life of the contract being 50 years. The company has paid the stipulated royalty yearly; but Mr. Young maintains the lease was merely a license that did not give the Verona company exclusive rights and that the intent of the respondent and understanding of the complainant have not been fulfilled and therefore the lease should be canceled. Should the case develop the ruling that a mining company which takes over a property for the purpose of extracting iron ore from it is not fulfilling its contract by simply paying the minimum royalty, it will undoubtedly result in the filing of numerous other suits to cancel leases in the iron ore country of Upper Michigan.

采 采

Tailing Disposal Device at Colburn Mill

By W. G. Zuehl

The dumping arrangement shown in Fig. 1 is used for the disposal of tailing. With it, it is possible to dump at any point, and the tailing is given a chance to spread and dry before another load is dumped on it, and thus prevent the large slides which frequently occur in tailing dumps.

The machine consists of a bucket *a*, in which the tailing is carried to the dump. It is suspended from a truck of two wheels, and has a capacity of about 9 cubic feet. The truck rests on a cable, 2½ inches in diameter. One end of this cable is anchored in the concrete at *l*, while the other end runs over a 60-foot high tower, and is held in place by means of a weight, consisting of a suspended box filled with rock.

The tailing passes from *i* to *a* through a funnel-like device *b*. The main reason for its presence is that some sort of a guard is

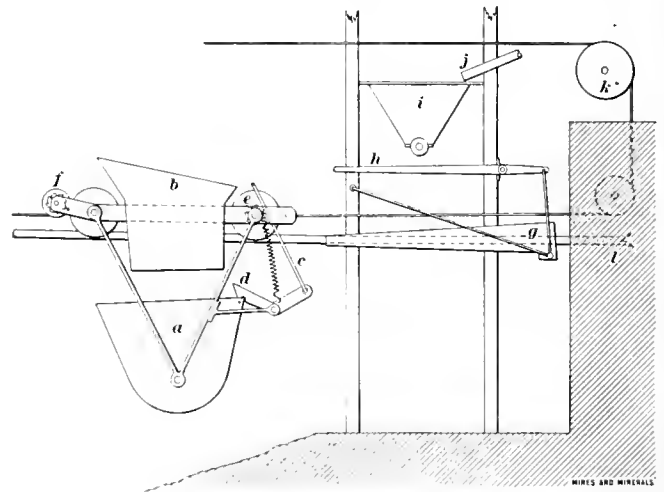

FIG. 1. TAILING DISPOSAL DEVICE

needed to keep the tailing from dripping on and clogging up the main cable.

A straight iron bar *c*, free to move in its pivot on the catch lever *d*, has a small projection about 4 inches from the upper end, which, when the bucket moves toward the dump, slides along the cog at *e*. But when the bucket is moved in the opposite direction, the cog is caught on the projection, and the bar *c* is pushed downward, raises the other end of catch lever *d*, and dumps the bucket. A pulley wheel *f* with cog attachment regulates the tautness of the small cable.

An iron sheet *g*, bent so as to lay over the cable is used to stop and start the bucket, by raising and lowering one end by means of the lever at *h*.

The tailing is run from the pipe *j* into the bin *i* and is released from this bin by means of a slide underneath, which is operated by a compressed air piston at the side.

The small cable which pulls the bucket out to the dump is wound several times around the drum *k* of a small electric hoist.

† S. L. Penfield, Am. J. Sci., XLVII, 1894, page 451.

‡ A. Frenzel, N. Jahrb. f. Min., 1896, II, page 125.

§ A. W. Stelzner, N. Jahrb. f. Min., 1893, II, page 114.

¶ A. Hutchinson, Phil. Mag., XLVIII, 1899, page 480.

|| G. T. Prior, Min. Mag., XIV, 1904, page 21.

Magnetic Separators

Conditions Under Which Ores Can Be Separated by Magnets Without Previous Concentration

The magnetic separation of ore is now very usually adopted as a secondary dressing of a concentrate previously made by other means. Cases, however, can be cited where magnetic separation

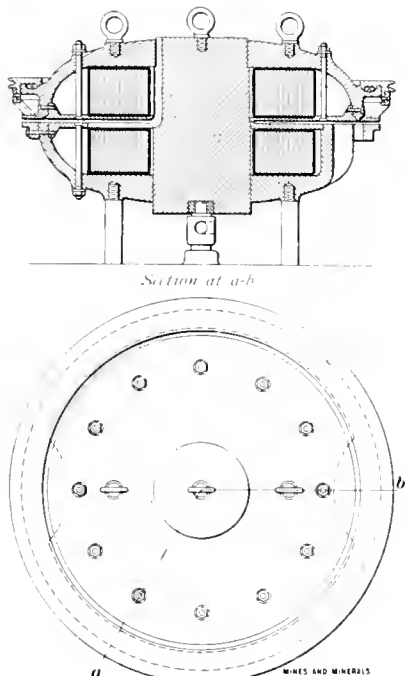

FIG. 1

can be profitably adopted instead of previous concentrating processes. For example, in the case of copper or lead ores where the slime formed floats, a considerable amount of wastage of material is caused in the concentrating; and in dealing with tin and wolfram ore much of the wolfram slimes and is lost in the washing. If therefore in this case the ore is capable of treatment by magnetic processes it would probably be found that much larger recoveries would be made, as slimes are magnetically recovered as easily as the larger particles. Very few minerals are found in a pure state, and the most common impurity is iron, which may be very small in quantity and yet be sufficient when placed under the influence of a powerful and intense magnetic field to allow the particles of mineral to be removed. Moreover, even if the mineral to be treated is not originally magnetic there are several methods which may be applied to the individual necessities of the ore to be treated in order to render it sufficiently magnetic for the purpose.

It will therefore be of interest to show a type of magnetic separator plant made in Great Britain according to the patents of Mr. Marcus Ruthenburg. The construction of this machine is shown in Fig. 1, from which it will be seen that it is a single magnet whose windings are enclosed within approximately hemispherical pole pieces, the magnetic flux passing through the adjustable circular air gap between the upper and lower poles. Close to the upper pole at which point the magnetic force is concentrated, a thin non-magnetic shield revolves and the material to be separated is passed through the field by means of quick return tables. As the magnetic particles pass under the influence of the upper pole and are intercepted by the revolving shield, they are carried to the brushes and removed to a convenient receptacle. The intensity of the field is controlled either by regulating the width of the air gap or by varying the strength of the current supplied to the windings. Fig. 2 shows the general arrangement of the separator with the feed-box removed and the means for accomplishing the rotation of the shield,

the progression of the ore, and regulation of the air gap will be seen from Figs. 1 and 2.

One of the chief points of difference which it is claimed distinguishes this design from that of many other magnetic separators, is that the material is subjected wholly to the action of a direct magnetic field instead of depending upon the more or less inefficient action of a stray field. The losses consequent upon the use of such stray fields often in some separators reach such a value that it is found necessary to use wooden or non-magnetic frames. The examination of this drawing will show that every part of this machine is accessible for overhauling and repair, particular care having been taken to leave all parts exposed which might require attention. Fig. 3 shows a typical installation of the separators driven electrically, from which the compactness of the plant is evident.

The adjustability of the machine enables it to be applied to a large variety of purposes. It has been economically and successfully used for separation of magnetite from its gangue, separation of low-grade black band from slate piles and the separation of hematite from gangue. In one case, where the plant was employed for the complete separation of copper from iron, the value of the recovered copper paid for the cost of separation. Another use which has been found for the plant has been the reduction of phosphorus and sulphur in iron ores, while among other separations may be mentioned that of manganese iron ore, tin-wolfram complexes, tin-monzite sands, tin from spathic iron; lead, zinc, and copper from barytes and from manganese, separations of mundic, tin, copper, and wolfram, and the separation of copper, antimony and silver occurring in iron and manganese, into antimonial copper carrying silver and manganese iron ore.

As a result of actual working trials it has been found that a separator having tables 6 inches wide and capacity of 1 ton per hour requires three-quarters of a kilowatt to operate it, while with a table 18 inches wide, and having a capacity of 3 tons per hour, the power required is only 1 kilowatt. The machines are wound with standard windings suitable for either 100 or 200 volts, although pressures of 500 volts have been employed for the purpose.

A somewhat similar application of the direct magnetic flux is employed where the separation is required for slimes in water, the machine illustrated being of course suitable in arrangement for

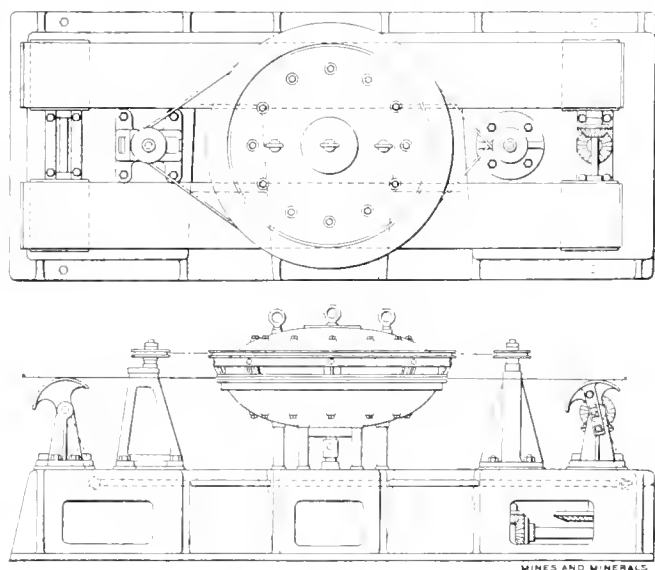

FIG. 2. PLAN AND ELEVATION

dry work. For sampling ores in assay offices, a somewhat simplified form of machine is adopted although adhering to the general arrangement described. It is intended for use in testing and separating samples, and is of a very compact description measuring 1 foot 8 inches in height, having an over-all diameter of 1 foot. It is built with a gap which is variable from $\frac{1}{4}$ inch to $1\frac{1}{4}$ inches, the gap being adjusted by means of a hand wheel placed on the top of

the latter—that large size of ore can be dealt with. The magnetic circuit is made of soft wrought iron of high permeability and is wound by a winding contained inside the bowls. The standard winding is arranged in two coils and four terminals are provided for putting the coils in series for 200 volts, or in parallel for 100 volts. As the separator is only of a small size, and as it is desirable to have as strong a field as possible the windings are designed for intermittent use only and are only placed in circuit for a maximum of 30

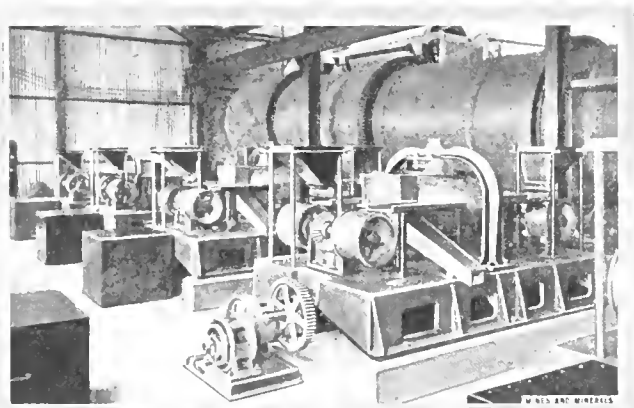

FIG. 3. MAGNETIC SEPARATING PLANT

minutes at a time in order to avoid excessive overheating. The power taken by the tester is 1 kilowatt with full strength of current, but as it is often necessary to have a weak field when separating ores which are strongly magnetic, a regulator is placed in series with the windings. This regulator has about 20 steps of resistance so that different strengths of field can be obtained. Both the testing equipment and the full-sized plants are most interesting examples of the latest developments in magnetic separation and will therefore be of considerable interest to mining engineers.

采 采

Variations of the Compass Needle

The United States Coast and Geodetic Survey, now of the Department of Commerce and Labor, have noted and tabulated the variations or magnetic declination of the compass needle from 1750 to 1911. The following information furnished by the Bureau is historical and valuable.

That the places where the magnetic needle points true to the Pole are limited to a small region of the earth is well known to land surveyors, navigators, and explorers, who, in the pursuit of their duties, have to be guided by the indications of the compass needle.

History furnishes interesting instances of the early ignorance of this fact. On September 13, 1492, consternation prevailed among the sailors on board Columbus's ship when it was noticed for the first time that the compass needle, instead of pointing a little east of the north star, as it had done all along since their leaving European shore, though, to be sure, by a gradually diminishing amount, then pointed somewhat west of the north star, and continued to do so as the ship passed to the westward. Thus it was that Columbus on his first voyage not only discovered a new world, but also the important practical fact that the compass needle not only does not point true to the pole but that it varies in its direction from place to place. Before that time the deviation of the needle from the true north was considered due to the imperfection of the mechanical construction of the magnetic needles, and was not before recognized as a distinct scientific fact. Inidentally it may be stated that during this first voyage Columbus passed through one place, a little west of Fayal Island, Azores, where the needle pointed to the true north, and a few years later Sebastian Cabot observed in other such place somewhat farther to the north, the observation of the two

thus roughly locating for the first time an agonic line, or line of no magnetic declination.

The earliest observation on land that the magnetic needle does not point exactly "true to the pole" appears to have been made by George Hartmann, a maker of compass sundials, who, in about the year 1570, found that at Rome the needle pointed 6 degrees east of true north. About 125 years later, after observations of the declination of the needle from the true north and south line began to multiply, it was found that at London between 1580, the date of the first declination observations at that place, and 1634, the needle had changed its direction of pointing from $11\frac{1}{2}$ degrees east to 4 degrees east, or a change to the westward of 7 degrees. Thus another important phenomenon was discovered, the cause of which remains without adequate solution up to the present time, though some of the best minds through the intervening years have studied it. This phenomenon is the so-called secular variation of the earth's magnetism, by the action of which changes of varying magnitudes are continuously occurring in the distribution of the earth's magnetism. The continual observation and study of these change and the correction of magnetic charts, as, for example, the lines of equal magnetic declination supplied to navigators, follow as a consequence.

To illustrate the magnitude of the above-mentioned change, and its practical effect upon human affairs: The magnetic needle at London continued to diminish its easterly bearing until about 1660 when it pointed due north, but continuing, however, its movement to the westward until, somewhere between the years 1810 and 1820, it pointed about 24 degrees to the west of true north, at which time its motion was reversed, and now it points about $15\frac{1}{2}$ degrees west. Thus from 1580 to about 1812, or in an interval of 232 years, the magnetic needle at London changed its direction from $11\frac{1}{2}$ degrees east to about 24 degrees west, or a total of about 35 degrees to the westward.

At Boston, in 1750, the needle pointed about $7\frac{1}{2}$ degrees west, decreasing to a minimum of about $6\frac{1}{2}$ degrees in 1785. Since about 1785 the westerly bearing of the needle has been increasing until now it is about $13\frac{1}{2}$ degrees west, or a change of $6\frac{1}{2}$ degrees in 127 years. Two streets, each a mile long, both starting from the same point, laid out to follow the compass, one established in 1785 and the other at the present time, would have their northern ends one-tenth of a mile apart. It is evident, therefore, that the change that takes place in the direction of the magnetic needle in this country, though not so large as in England, is sufficient in amount to a considerable quantity in the course of a century when applied to lines laid out on the ground.

All of the earlier American land surveys were made with the compass, and the magnetic bearings of the lines are still of record as defining the boundaries of the areas then surveyed, so that it is a matter of first necessity to know the amount of change in the compass direction since the date of the early survey, if there is need to reestablish the lines of that survey. And such information will always be a necessity, as those early compass surveys must be consulted in defining the original land boundaries.

About 70 years ago, in the plan for the reorganization of the survey of the coast, explicit provision was made for the making of "all such magnetic observations as circumstances and the state of the annual appropriations may allow," and Congress, in its annual appropriations, clearly recognizes the importance of such work. With the advancing years the requests for practical information from surveyors, mariners, and others increased to such an extent that in 1899 it was found necessary to create a distinct division, that of terrestrial magnetism, in the office of the Survey, and to assign to it, under the supervision of the superintendent, the general charge of the systematic and thorough magnetic survey of the United States and outlying countries under its jurisdiction. The entire function of this branch of the Survey's activities is to gather information regarding the magnetic needle, and to disseminate it in available form for practical and scientific use in advancing the knowledge of one of the most perplexing natural phenomena of the great globe upon which we live.





P
Tech
C

Colliery Engineer.

v. 32(1911/12)

**PLEASE DO NOT REMOVE
SLIPS FROM THIS POCKET**

**UNIVERSITY OF TORONTO
LIBRARY**

