

THE LIBRARY
THE FIELD ARTILLERY SCHOOL
FORT SILL, OKLAHOMA



CANCELLED

ACCESSION NUMBER

A

PROPERTY OF U. S.

TA 145 332

"PROPERTY OF U. S. ARMY"



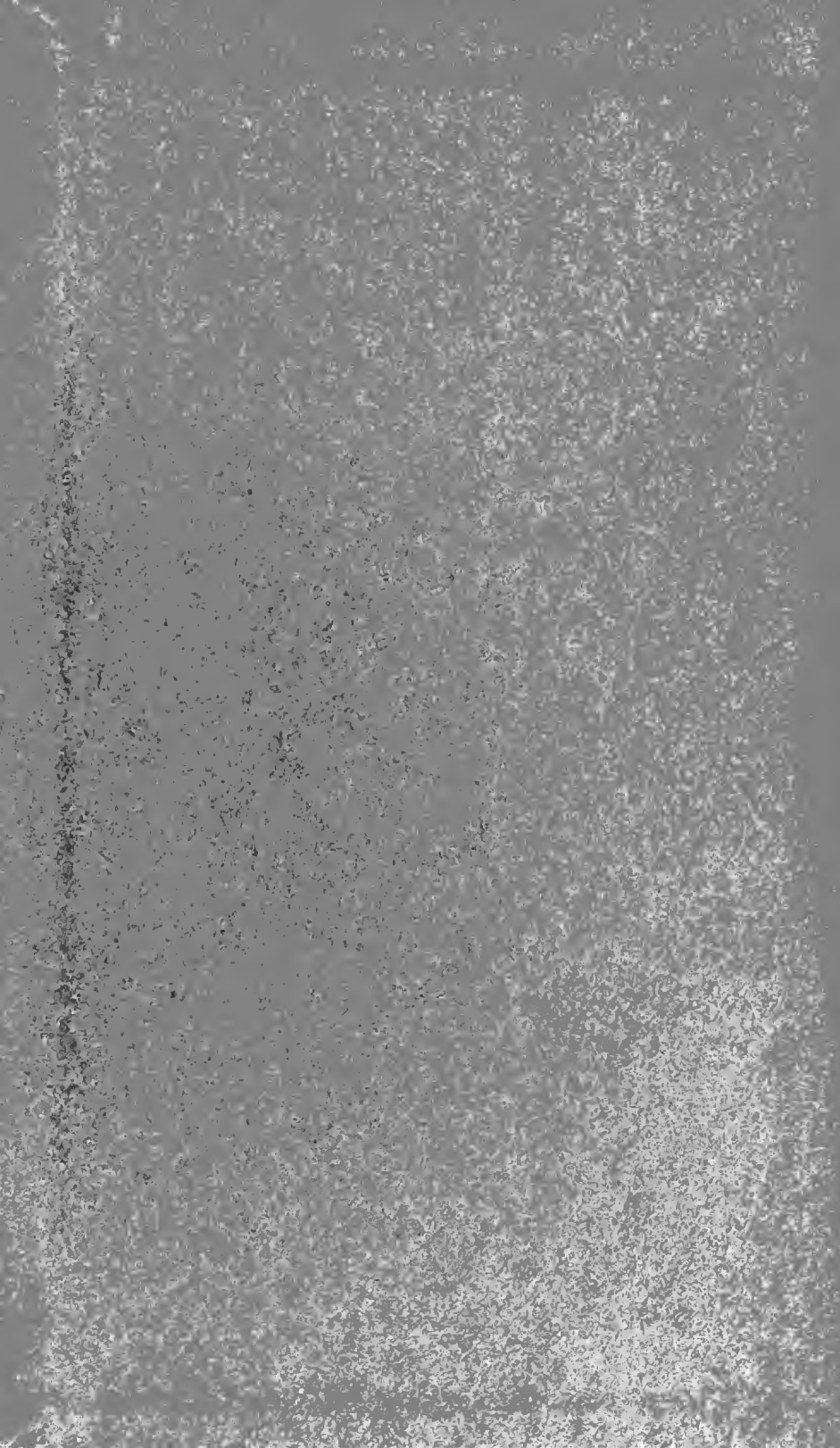



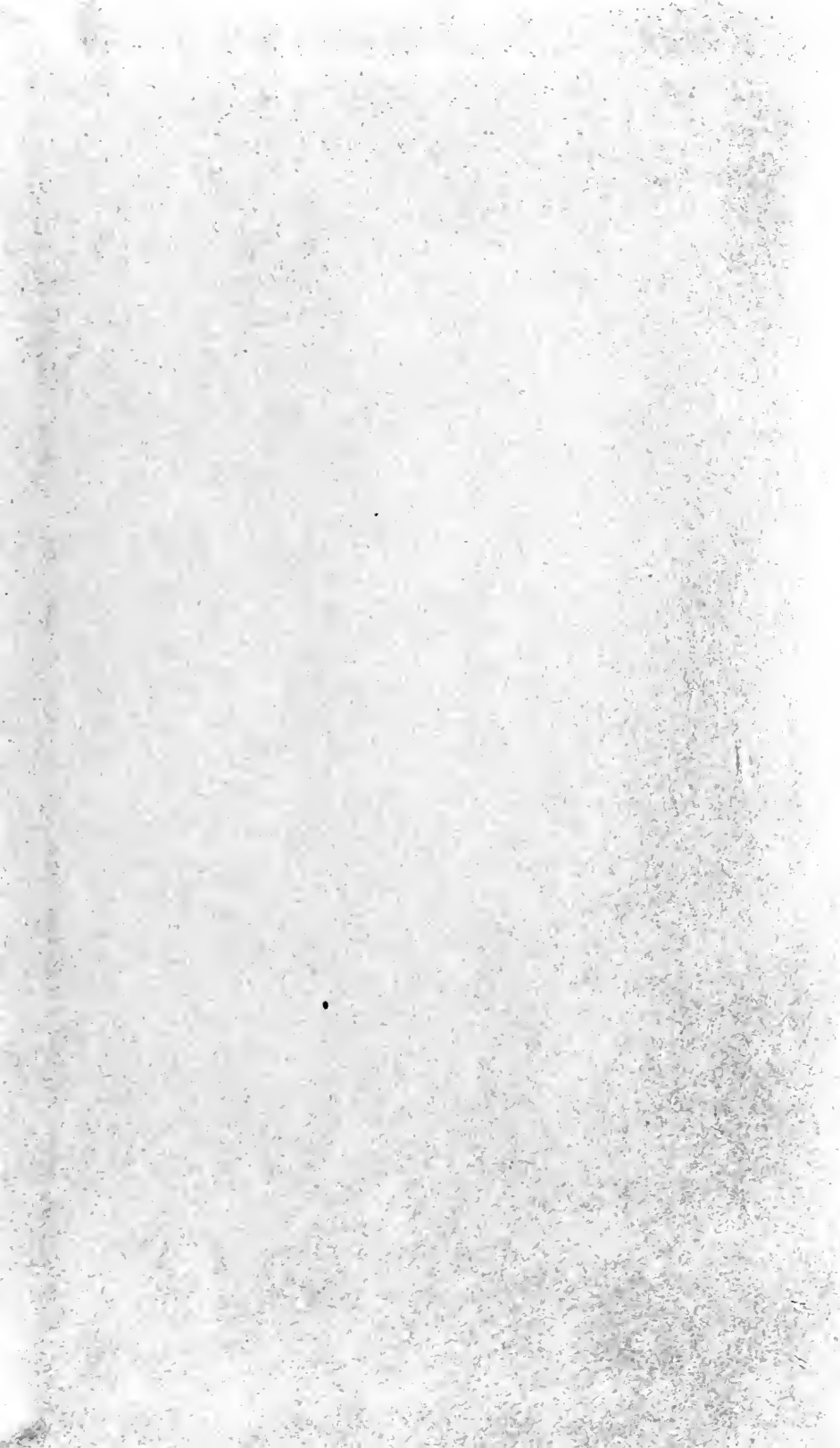

Digitized by the Internet Archive
in 2007 with funding from
Microsoft Corporation

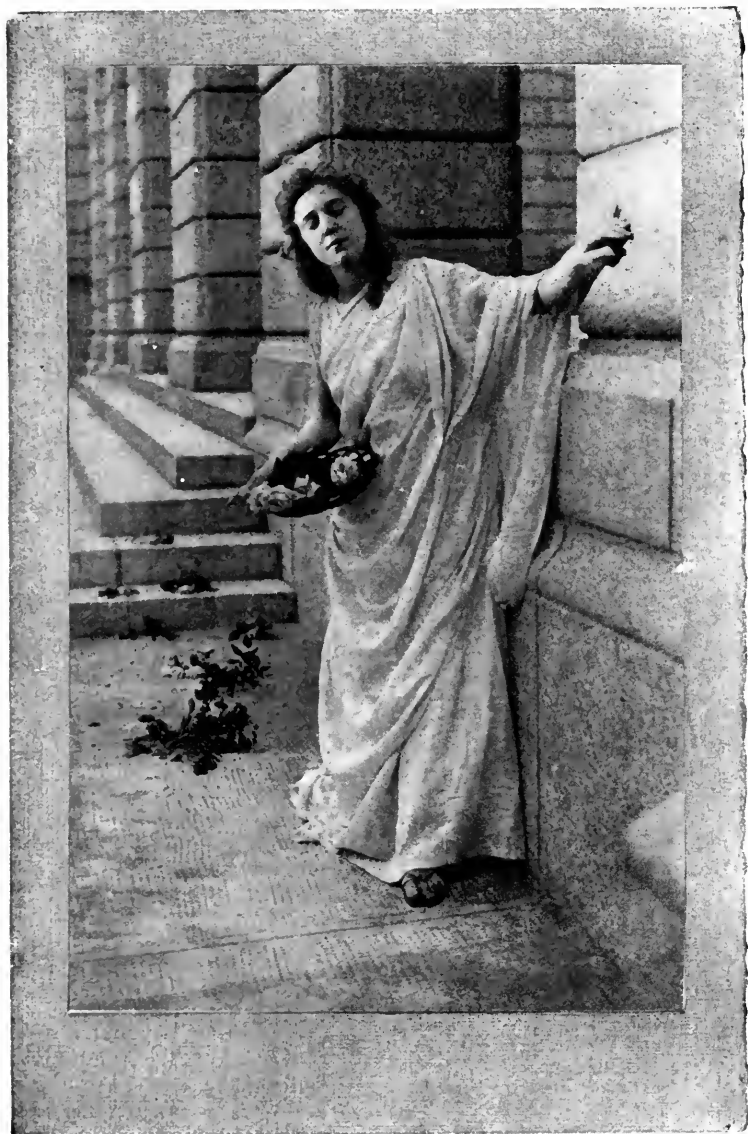

NYDIA

STUDY No. 1—See Page 401

WILL H. WALKER

**Complete Self-Instructing Library
of Practical Photography**

VOLUME VI

**At-Home Portraiture, Flashlight,
Interiors, Lenses**

CANCELLED

J. B. SCHRIEVER
Editor-in-Chief

Popular Edition

PUBLISHED BY
American School of Art and Photography
SCRANTON, PA., U. S. A.
1909

**COPYRIGHT, 1908, 1909, BY
AMERICAN SCHOOL OF ART AND PHOTOGRAPHY,
SCRANTON, PA., U. S. A.**

**ENTERED AT STATIONER'S HALL, LONDON, ENGLAND.
All rights and translations reserved.**

PREFACE

1. In gathering together the material for this volume, the editors have not lost sight of the fact that not alone the amateur, but the professional also, is frequently desirous of making portraits *in the home*, with all the surroundings of home that help to make up the effective studies now so much in vogue.

2. As a foundation for portrait work in the home, a knowledge of the photographing of interiors is most essential. This teaches us the handling of furniture and similar accessories; the treatment and control of light in small areas; the correct judging of exposures under difficult circumstances.

3. From this branch of the work, it is but a step to the introduction of figures into the picture, and portraiture in the home follows as a natural sequence. We can thus see that successful At-home Portraiture is dependent, to a great extent, on the correct handling of interiors.

4. The making of interior photographs differs considerably from exterior work, yet the general principles of manipulating the camera are the same. One has to learn the value of the light; also exercise his power of selection and arrangement to a different degree, as the subject material is of another type.

5. With a thorough knowledge of the subjects just mentioned, and the ability to obtain technically correctly lighted negatives, flashlight photography will present no difficulties, for the only difference between flashlight photography and ordinary photography, where daylight is used, is in the source of illumination. For this reason, it is very important that one refrain from attempting flashlight work

PREFACE

until one has a comparatively good idea of the manner in which ordinary work is produced, using daylight as the illuminant.

6. At this juncture particular attention should be given the subject of lenses, as a knowledge of their wide range of use is of inestimable value. The training that should have resulted from studying the first five volumes of this library now demands more than a passing acquaintance with the lens and shutter; therefore, careful study should be made of the various chapters forming the latter portion of this volume. Of particular value is Mr. S. Lawrence's talk on "Photographic Lenses—Their Nature and Use."

7. The apparatus necessary for the various phases of work taken up in detail in this volume is easily constructed, or bought at little expense, and, together with the instruction given, will enable anyone to produce excellent results.

8. We urge a systematic study of each chapter and every paragraph in each chapter. Only in this way can familiarity with the various processes and manipulations be gained. Should difficulties be encountered, reference to the special chapters will obviate them. *Prevention and Remedy* are given in concise terms, following each special subject. All practice work should be preceded by a careful study of these Difficulty Chapters. Only in this way will the greatest amount of benefit be derived.

9. In order that the best results be obtained, and that waste of material be reduced to a minimum, proofs should be made from all experimental results, and these filed, together with the data describing the manner in which the experiment was performed, in a proof file. A regular letter file, which is arranged alphabetically and may be procured from any stationer, will answer this purpose admirably.

TABLE OF CONTENTS

VOLUME VI

	PAGE
PREFACE	5
CHAPTER I.	
INTERIOR PHOTOGRAPHY	
PART I—PHOTOGRAPHING INTERIORS OF RESIDENCES	19
CHAPTER II.	
MATHEMATICAL METHOD OF MEASURING LIGHT.....	35
CHAPTER III.	
INTERIOR PHOTOGRAPHY	
PART II—DEVELOPING—EXAMPLES.....	39
CHAPTER IV.	
INTERIOR PHOTOGRAPHY	
PART III—CONTROLLING HALATION BY SPECIAL DEVELOPMENT	51
CHAPTER V.	
DIFFICULTIES—INTERIOR PHOTOGRAPHY	59
CHAPTER VI.	
AT-HOME PORTRAITURE WITH HOME SURROUNDINGS....	63
CHAPTER VII.	
DIFFICULTIES—AT-HOME PORTRAITURE WITH HOME SURROUNDINGS	75

CONTENTS

	PAGE
CHAPTER VIII.	
AT-HOME PORTRAITURE	
PART I—INTRODUCTION.....	77
CHAPTER IX.	
AT-HOME PORTRAITURE	
PART II—CONTROLLING THE LIGHT.....	81
CHAPTER X.	
AT-HOME PORTRAITURE	
PART III—GENERAL INFORMATION.....	87
CHAPTER XI.	
AT-HOME PORTRAITURE	
PART IV—BACKGROUNDS.....	91
CHAPTER XII.	
AT-HOME PORTRAITURE	
PART V—MAKING GENERAL PREPARATIONS.....	95
CHAPTER XIII.	
AT-HOME PORTRAITURE	
PART VI—PLAIN PORTRAIT LIGHTING.....	101
CHAPTER XIV.	
AT-HOME PORTRAITURE	
PART VII—POSING DETAILS.....	115
CHAPTER XV.	
AT-HOME PORTRAITURE	
PART VIII—IMPORTANT GENERAL NOTES.....	121
CHAPTER XVI.	
AT-HOME PORTRAITURE	
DIFFICULTIES—PLAIN PORTRAIT LIGHTING.....	127
CHAPTER XVII.	
AT-HOME PORTRAITURE	
PART IX—REMBRANDT LIGHTING—INTRODUC- TION AND BRIEF GENERAL INSTRUCTION.....	131
CHAPTER XVIII.	
AT-HOME PORTRAITURE	
PART X—REMBRANDT LIGHTING—DETAILED INSTRUCTION	139

CONTENTS

	PAGE
CHAPTER XIX.	
AT-HOME PORTRAITURE	
DIFFICULTIES—REMBRANDT LIGHTING.....	147
CHAPTER XX.	
AT-HOME PORTRAITURE	
PART XI—BROAD PROFILE LIGHTING.....	151
PART XII—REMBRANDT PROFILE LIGHTING.....	154
CHAPTER XXI.	
BABY AND CHILD PHOTOGRAPHY—INTRODUCTION AND BRIEF GENERAL INSTRUCTION.....	167
CHAPTER XXII.	
BABY AND CHILD PHOTOGRAPHY—DETAILED INSTRUCTION	173
CHAPTER XXIII.	
CHILDREN'S PORTRAITS IN DRAPERY.....	179
CHAPTER XXIV.	
PHOTOGRAPHING CHILDREN OUTDOORS.....	187
CHAPTER XXV.	
FIRELIGHT EFFECTS BY DAYLIGHT.....	193
CHAPTER XXVI.	
GROUPS	199
CHAPTER XXVII.	
DIFFICULTIES—GROUPS	209
CHAPTER XXVIII.	
GENERAL FLASHLIGHT PHOTOGRAPHY.....	213
CHAPTER XXIX.	
FLASHLIGHT PORTRAITURE	221
CHAPTER XXX.	
GROUPS AND INTERIORS BY FLASHLIGHT.....	237
CHAPTER XXXI.	
DIFFICULTIES—FLASHLIGHT PHOTOGRAPHY.....	243
CHAPTER XXXII.	
REFLEX CAMERA IN CONJUNCTION WITH FLASHLAMP...	247

CONTENTS

	PAGE
CHAPTER XXXIII.	
PHOTOGRAPHIC LENSES—THEIR NATURE AND USE.....	257
CHAPTER XXXIV.	
WHY AN ANASTIGMAT IS DESIRABLE.....	293
CHAPTER XXXV.	
STOPS OR DIAPHRAGMS.....	301
CHAPTER XXXVI.	
PHOTOGRAPHIC SHUTTERS.....	307
CHAPTER XXXVII.	
BAUSCH & LOMB LENSES.....	317
CHAPTER XXXVIII.	
GOERZ ANASTIGMAT LENSES	333
CHAPTER XXXIX.	
COOKE LENSES	351
CHAPTER XL.	
VOIGTLANDER LENSES.....	359
CHAPTER XLI.	
PORTRAIT LENSES	373
CHAPTER XLII.	
TELEPHOTOGRAPHY	387
CHAPTER XLIII.	
PROJECTING AND ENLARGING.....	395
CHAPTER XLIV.	
HOW THE STUDIES ILLUSTRATING THIS VOLUME WERE MADE	401

ILLUSTRATIONS FOR PHOTOGRAPHIC LENSES—THEIR NATURE AND USE

BY S. LAWRENCE

ILLUS. NUMBER	TITLE	PAGE	PAR. REF.
1	REFRACTION	258	576
2	DISPERSION	259	580
3	DISPERSION (SHOWING BAND OF COLORS)....	260	580
4	CHROMATIC ABERRATION	261	582
5	CORRECTION OF CHROMATIC ABERRATION....	262	583
6	SPHERICAL ABERRATION	263	584
7	FORMS OF LENSES.....	264	586
8	CURVATURE OF FIELD.....	267	593
9	CURVATURE OF FIELD.....	267	594
10	COVERING POWER OF LENS.....	270	600
11	CURVATURE OF LENS.....	270	601
12	CRITICAL DEFINITION	271	602
13	RELATIVE POSITION OF PLATE AND FIELD....	272	603
14	POSITION OF PLATE AND FIELD.....	272	603
15	FOCUSING OF A LENS.....	273	605
16	EQUIVALENT FOCUS	275	608
17	ILLUSTRATION OF BACK FOCUS.....	276	610
18	RATIO OF DISTANCE AND SIZE.....	277	613
19	INFLUENCE OF APERTURE ON DEPTH OF FOCUS	282	619
20	RELATIVE SPEED OF LENSES.....	284	625
21	RELATIVE SPEED OF LENSES.....	285	627

ILLUSTRATIONS

ILLUS. NUMBER	TITLE	PAGE	PAR. REF.
1	SIMPLY ARRANGED DINING-ROOM.....	42	78
2	A DINING-ROOM.....	45	81
3	GENERAL INTERIOR VIEW.....	46	82
4	AVOIDING HALATION.....	54	102
	ORDINARY PLATE—SPECIAL DEVELOPMENT. NON-HALATION PLATE—ORDINARY DEVELOPMENT.		
5	AT-HOME PORTRAIT.....	65	131
6	AT-HOME PORTRAITURE WITH HOME SURROUNDINGS	66	132
7	SPECIAL EXAMPLES OF AT-HOME PORTRAIT- TURE BY HENRY HAVELOCK PIERCE.....	69	136
8	AT-HOME PORTRAITURE—WINDOW PORTRAITS	70	137
9	INGENTO BACKGROUND CARRIER.....	88	174
10	CONSTRUCTION OF BACKGROUND FRAME....	93	185
11	CONTROLLING SCREEN IN WINDOW.....	96	193
12	PLAIN PORTRAIT LIGHTING—FLOOR PLAN..	103	208
13	PLAIN PORTRAIT LIGHTING—AT-HOME PORTRAITURE	107	214
14	PLAIN PORTRAIT LIGHTING—AT-HOME PORTRAITURE	107	216
15	MORRISON VIGNETTER	124	266
16	REMBRANDT LIGHTING—AT-HOME PORTRAITURE	133	289
17	REMBRANDT LIGHTING—AT-HOME PORTRAITURE	133	291

ILLUSTRATIONS

ILLUS. NUMBER	TITLE	PAGE	PAR. REF.
18	REMBRANDT LIGHTING—FLOOR PLAN.....	136	297
19	REMBRANDT PROFILE LIGHTING—FLOOR PLAN	155	350
20	SUITABLE PROFILES FOR PLAIN AND REMBRANDT LIGHTINGS	157	352
21	SERIES OF INFANTS' PICTURES.....	169	376
22	CHILD DRAPERY PORTRAIT.....	181	402
23	HAND POSING	182	406
24	STATUETTE	182	408
25	AT-HOME PORTRAITURE—OUT-OF-DOORS....	189	420
26	FIRELIGHT EFFECT BY DAYLIGHT.....	195	423-5
27	GROUP OF TWO—PYRAMIDAL ARRANGE- MENT	169	435
28	GROUP OF THREE—PYRAMIDAL ARRANGE- MENT	169	436
29	GROUP OF THREE—MOTHER AND CHILDREN.	201	437
30	FAMILY GROUP	201	438
31	MAGNESIUM MACHINE	214	475
32	EASTMAN FLASH LAMP.....	216	480
33	STYLE "D" LUXO FLASH LAMP.....	217	480
34	NICHOLS' PROFESSIONAL FLASH LAMP.....	222	489
35	NICHOLS' JUNIOR FLASH LAMP.....	222	489
36	SECTIONAL FRONT VIEW OF NICHOLS' FLASH LAMP	223	491
37	SECTIONAL REAR VIEW OF NICHOLS' FLASH LAMP	224	492
38	LENS HOOD	226	502
39	FLOOR PLAN—PLAIN LIGHTING BY FLASH- LIGHT	228	508
40	CHILD'S PORTRAIT MADE WITH NICHOLS' FLASH LAMP	231	508
41	FLOOR PLAN—REMBRANDT LIGHTING BY FLASHLIGHT	229	509
42	EXAMPLE OF WORK WITH FOCAL PLANE SHUTTER	249	559

ILLUSTRATIONS

ILLUS. NUMBER	TITLE	PAGE	PAR. REF.
43	EXAMPLE OF WORK WITH FOCAL PLANE SHUTTER	249	560
44	EXAMPLE OF WORK WITH FOCAL PLANE SHUTTER	249	570
45	REFLEX CAMERA WITH ELECTRIC CONNEC- TION	250	562
46	REFLEX CAMERA WITH ELECTRIC CONNEC- TION	250	562
47	DIAGRAM OF ELECTRIC CONNECTION FOR REFLEX CAMERA	252	563
49	GOERZ XL SECTOR SHUTTER.....	309	693
50	"B. & L." VOLUTE SHUTTER.....	309	693
51	PHOTOGRAPHS MADE WITH MULTI-SPEED SHUTTER ON A 3A KODAK.....	310	705
51a	SECTIONAL VIEW SHOWING REFLEX PRIN- CIPLE	316a	718
51b	GRAFLEX FOCAL PLANE SHUTTER.....	316a	718
51c	SHOWING RELATIVE POSITION OF FOCAL PLANE SHUTTER	316a	718
51d	CURTAIN OF GRAFLEX FOCAL PLANE SHUT- TER	316a	718
51e	WOLLENSAK AUTEX SHUTTER.....	316b	719
51f	WOLLENSAK OPTIMO SHUTTER.....	316b	719
51g	WOLLENSAK STUDIO SHUTTER.....	316b	719
52	BAUSCH & LOMB-ZEISS TESSAR LENS, SEC- TIONAL VIEW OF.....	318	722
53	BAUSCH & LOMB TESSAR 11b Lens.....	321	723
54	BAUSCH & LOMB-ZEISS TESSAR LENS, SE- RIES I-C.....	321	735
55	BAUSCH & LOMB-ZEISS PROTAR LENS, SE- RIES IV.....	321	741
56	BAUSCH & LOMB-ZEISS PROTAR LENS, SEC- TIONAL VIEW OF.....	323	741
57	BAUSCH & LOMB-ZEISS PROTAR LENS, SE- RIES VII-A.....	322	748

ILLUSTRATIONS

ILLUS. NUMBER	TITLE	PAGE	PAR. REF.
58	BAUSCH & LOMB-ZEISS PROTAR LENS, SERIES 7-A, SECTIONAL VIEW OF.....	324	748
59	PHOTOGRAPH MADE WITH COMPLETE BAUSCH & LOMB-ZEISS PROTAR LENS.....	325	753
60	PHOTOGRAPH MADE WITH REAR COMBINATION BAUSCH & LOMB-ZEISS PROTAR LENS	325	754
61	BAUSCH & LOMB-ZEISS PROTAR LENS DEMONSTRATION	326	755
62	BAUSCH & LOMB PLASTIGMAT LENS.....	322	760
63	BAUSCH & LOMB PLASTIGMAT LENS, SECTIONAL VIEW OF.....	328	760
64	MT. SHASTA PHOTOGRAPHED WITH DOUBLET PLASTIGMAT LENS	331	761
65	MT. SHASTA PHOTOGRAPHED WITH SINGLE LENS COMBINATION	331	761
66	BAUSCH & LOMB RAPID UNIVERSAL LENS..	322	762
67	BAUSCH & LOMB RAPID UNIVERSAL LENS, SECTIONAL VIEW OF.....	329	762
68	GOERZ CELOR LENS.....	332	803
69	GOERZ CELOR LENS, SECTIONAL VIEW OF....	332	803
70	GOERZ DAGOR LENS.....	332	810
71	GOERZ DAGOR LENS, SECTIONAL VIEW OF..	332	810
72	DIAGRAM SHOWING ANGLE OF VIEW OF LENS	346	820
73	GOERZ-ANSCHUTZ CAMERA	347	821
74	GOERZ-ANSCHUTZ STEREOSCOPIC CAMERA..	348	828
75	COOKE PORTRAIT LENS, SERIES II.....	352	833
76	VOIGTLANDER'S COLLINEAR LENS, SERIES II.	367	890
77	VOIGTLANDER'S COLLINEAR LENS, SERIES III	368	890
78	VOIGTLANDER'S DYNAR LENS.....	369	892
79	COLLINEAR LENS CELLS.....	369	893
80	VOIGTLANDER'S HELIAR LENS.....	370	894
81	VOIGTLANDER'S EURYSCOPE LENS.....	371	896
82	DALLMEYER PORTRAIT LENS.....	379	900

ILLUSTRATIONS

ILLUS. NUMBER	TITLE	PAGE	PAR. REF.
83	VOIGTLANDER'S PORTRAIT EURYSCOPE LENS.	374	903
84	VOIGTLANDER'S HELIAR LENS.....	375	904
85	MOUNTING FOR BAUSCH & LOMB PORTRAIT LENSES	379	908
86	SECTIONAL VIEW OF BAUSCH & LOMB-ZEISS PORTRAIT UNAR LENS.....	376	908
87	SECTIONAL VIEW OF BAUSCH & LOMB POR- TRAIT LENS, SHOWING DIFFUSING SYS- TEM	378	910
88	NORMAL PERSPECTIVE	380	913
89	DISTORTED PERSPECTIVE	380	913
90	WHY A SHORT FOCUS LENS DISTORTS, DIA- GRAM SHOWING	381	914
91	PHOTO BY DUDLEY HOYT.....	385	917
92	TELEPHOTO LENS, SECTIONAL VIEW OF.....	388	930
93	BAUSCH & LOMB TELEPHOTO LENS.....	391	930
94	GOERZ TELEPHOTO LENS.....	391	930
95	DALLMEYER TELEPHOTO LENS.....	389	930
96	VOIGTLANDER'S TELEPHOTO LENS.....	389	930
97	TELEPHOTO DEMONSTRATION	392	931
98	SECTIONAL VIEW OF TRIPLE CONDENSING LENSES	396	940
99	SECTIONAL VIEW OF DOUBLE CONDENSING LENSES	396	940
100	BAUSCH & LOMB PROJECTION LENS.....	391	946
101	SECTIONAL VIEW OF PROJECTION LENS....	398	946

STUDIES AND HOW THEY WERE PRODUCED

STUDY NUMBER	TITLE	AUTHOR	STUDY PAGE	HOW MADE PAGE
1	NYDIA.....	WILL H. WALKER		<i>Frontispiece</i>
2	“BONNE NUIT”..	LOUIS FLECKENSTEIN	21	401
3	“DO YOU WANT A BITE?”.....			
	MRS. NANCY FORD CONES	22	401
4	PORTRAIT OF CHILD..	CHAS. E. FAIRMAN	41	401
5	LADY AT WINDOW..	EVA GODLEY ROLFE	53	402
6	MOTHER AND CHILD.....			
	MARY G. HUNTSMAN	83	402
7	PUNISHMENT.....	HELEN W. COOK	84	402
8	LADY AND CHILD IN OPEN DOOR..			
	J. H. FIELD	108	402
9	AT-HOME PORTRAIT..	MATHILDE WEIL	134	402
10	THE CUP THAT CHEERS.....			
	MRS. M. S. GAINES	158	403
11	“FAIRY TALES”.....			
	MRS. NANCY FORD CONES	170	403
12	AT-HOME PORTRAIT.....	PERRY STUDIO	190	403
13	MAKING PAPER DOLLS.....			
	FRANCES B. JOHNSTON	196	403
14	“TWO AGAINST ONE”..	JOHN S. NEARY	202	403
15	“GOOD MORNING”....	W. H. PARTRIDGE	232	404

CHAPTER I.

Interior Photography.

Part I.

Photographing Interiors of Residences.

10. **Introduction.**—Probably one of the most difficult subjects to handle by means of photography is the securing of technically correct interiors. It is an extremely fascinating branch of the work, however, and by the person who will apply thought and diligent effort, making a careful study of the various subjects, and using the result of each exposed plate as a guide for manipulating the next succeeding one, there will be little difficulty experienced in rapidly mastering interior photography. However, at the outset it will be well to understand that a great deal of practice will be required before one will be able to produce work of high character. In this volume we will treat only of the photographing of residence interiors and minor interior views, as the commercial side is covered in detail in Volume IX—Commercial and Scientific Photography. By carefully observing the directions given in the following instruction, either the beginner, amateur or professional photographer will be able to secure not only technically correct pictures, but artistically arranged interior photographs.

11. For interior work there are three main points of importance to consider, which must be borne in mind at all times. If for any reason they are slighted, the final result will show the deficiency. In the first place, the arrange-

ment of the subject material is of extreme importance, yet many times it is not possible to alter the position of objects, as, in order to have a true record of the appearance of the room, no material change must be made. Instead of changing accessories alter the point of view.

12. Spotty effects of light and shade must be avoided, as there should be but one strong predominating item of interest, which must surpass all other items in importance. Lighting either too strong or too contrasty tends to accentuate and direct the attention to that particular object.

13. The general lighting of interiors is a serious problem; one which is almost impossible to handle correctly, owing to arrangement of windows and other sources of home illumination. Frequently, far better results can be secured by employing artificial light—flashlight, for instance—in order to illuminate deep shadows which cannot be reached by daylight. This department of photography is thoroughly covered under the heading, “Flashlight Photography,” Chapter No. XXX, of this volume.

14. The third matter for consideration is the exposure, yet by following the instructions given in this lesson but little difficulty will be encountered in securing proper exposure.

15. The three main points for consideration are, therefore, *arrangement of subject material, securing proper lighting, and giving correct exposure.*

16. **The Camera and Lens.**—Any ordinary camera may be employed for general interior work, but it is most convenient to have an instrument with a rising front. If using a $6\frac{1}{2} \times 8\frac{1}{2}$ camera the rise of the lens board should not be less than $2\frac{1}{2}$ inches, while if employing a 5×7 or 4×5 camera, $1\frac{1}{2}$ to 2 inches is sufficient. Wide-angle lenses are best for interiors, as with them more of the room can be admitted into the view. However, in some instances ordinary lenses can be satisfactorily employed. The lens should be as good as circumstances will permit the photographer to procure. A single achromatic lens should not be used in any event, however, as distortion of lines is



"BONNE NUIT"

STUDY No. 2—See Page 401

LGUIS FLECKENSTEIN



"DO YOU WANT A BITE?"

STUDY No. 3—See Page 401

MRS. NANCY FORD CONES

sure to result. While a good rectilinear lens will answer practically every purpose, yet, if it is possible to employ an anastigmat lens it is to be recommended, as the latter lens greatly exceeds the speed of the rectilinear owing to its more perfect correction, which enables its use at greater aperture. If the amount of exposure is of little or no importance, results exactly as good will be secured with the regular rectilinear lens fitted to an ordinary camera, but it must be stopped down to quite a small diaphragm opening. As a rule it is necessary to work in crowded positions, and for that reason a lens of great focal length cannot be successfully employed. In a case of this kind it is quite important that one should be equipped with an extra wide-angle lens, which may be attached to the camera in place of the regular rectilinear.

17. The wide-angle lens, for the majority of interiors, is almost indispensable, as with it many obstacles are overcome. These lenses may be secured in separate cells, which can be screwed into the barrel of the regular rectilinear lens, replacing the latter with the former. They are also supplied in solid barrels. The latter is really the better model to employ, because it permits of instant change from rectilinear to wide-angle, and *vice versa*. Possessing these two lenses, one is equipped for thoroughly practical work. A good wide-angle lens may be obtained for from \$10 to \$20; while the cells which can be fitted into the barrel of your regular rectilinear lens may be purchased, in a neat leather covered case, at \$4 or \$5.

18. For those having only a small camera, fitted with a rapid rectilinear lens only, and who do not wish to purchase an expensive wide-angle lens, or even the wide-angle cells, we would advise the selection of a wide-angle lens attachment. This attachment can be obtained for \$1.00 or \$1.50. The purpose of these attachments is to increase the cutting angle of the lens. They are placed in front of the regular lens and effect an optical combination, which changes the regular instrument from a simple rectilinear to a wide-angle lens. They are mounted in neat brass cells,

polished and nickel-plated, with adjustable springs to fit like a cap over the hood of the regular lens. When purchasing an attachment of this kind, be sure to give the exact outside measurements of the lens.

19. In order to produce the best results and admit as large an amount of the interior view as possible, we advise the purchasing of an extremely wide-angle lens, which should cut from 90° to 100° . The covering power and definition must be thoroughly considered. The lens should be perfectly rectilinear, and the corrections must be most perfect, in order that the image will be free from distortion to the margin of the plate. With a lens of this character it is easy to show the greater part of the room you are photographing, and at the same time procure true and perfect lines. Beginning with page 257, in this volume, you will find complete instruction on the subject of lenses.

20. **Tripod.**—The tripod should be firm and adjustable to customary limits of height. In interior photography, the necessary exposure being of considerable length, there must be absolutely no danger of the camera jarring or moving during the exposure. As it is sometimes necessary to work on polished floors, it would be advisable to provide yourself with rubber tips to slip over the sharp points of the tripod feet, to prevent the camera from slipping. A better accessory, however, is three strips of wood, each 30 inches long by 2 inches wide, and $\frac{1}{4}$ inch thick. Fasten together with a thumb screw running through one end of each, thus permitting them to be spread out in any direction. Six to ten holes should be bored in the ends of these strips, to receive the end of the tripod legs. When not in use this appliance folds into a very small space for carrying. Tripod stays are procurable through the supply dealer, and with them the tripod is made perfectly rigid and cannot slide; but these do not protect highly polished floors from being scratched by the metallic points at the ends of the tripod legs.

21. **Plates to Use.**—For all interior work non-halation

plates are the best to use, as they tend to prevent halation. Ordinary plates can be used, however, by working carefully. In fact the majority of interiors are made with ordinary plates, and where they are properly employed good results can be obtained; but if treated as an ordinary exposure your results will not be satisfactory.

22. **Cause of Halation.**—Halation is due mainly to the reflection of light from the back surface of the glass or other support of the sensitive film, or even the inside of the plate-holder. To overcome this, plate manufacturers have placed upon the market the non-halation plate.

23. **Non-Halation Plates.**—These plates are double coated and especially made to prevent halation. They are recommended for photographing interiors in which strong light, entering through windows admitted into the view, must be contended with. They are first coated with a slow emulsion, and then, for a second time, with a rapid emulsion.

24. **Ortho or Isochromatic Plates.**—These should be used when photographing interiors of churches and public buildings, in which are stained glass windows, for, being color sensitive, they will give the true relative values of the different colors.

25. **Non-Halation Ortho Plates.**—We have briefly explained the reasons, under the foregoing headings, for the choice of plate best to use for a given purpose. In so doing, however, it was not intended to convey the impression that good results may not be secured with any other brand of plate if used intelligently. The ordinary plate, the non-halation plate and the orthochromatic plate each have their special advantages for particular classes of photography, but there are times when it is necessary to have a plate that is not only non-halation, but also corrected so as to give the best of color values. Many times in making interior views highly colored objects, such as upholstered furniture, draperies, etc., will not reproduce properly, unless an orthochromatic plate be used. At the same time windows may enter into the angle of view, and thus re-

quire that the plate have non-halation properties. The Non-Halation Ortho plate and the Isonon plate which are combinations of the two plates just mentioned, are practically universal in their application, and of particular value when photographing interiors where color values and contrasts of light and shade must receive special consideration.

26. Backed Plates.—The backing of ordinary dry plates is one of the most suitable methods to employ to overcome halation where non-halation plates cannot be obtained. This backing must be in optical contact with the glass; it must have the same “refractive index” as the glass in order to stop reflections from the back; it should contain nothing injurious to the sensitive film; it must not scratch or chip easily, as this would cause dust, which would leave pin-holes in the negative; it should be easily applied and of quick drying quality; it should, also, permit of being readily removed. Backed plates can be purchased ready for use, or can be backed at home. The following formula produces an excellent backing, which can be applied with a brush:

27. Backing Mixture.—

Gum Solution (ordinary mucilage or gum arabic)	1 oz.
Caramel	1 oz.
Burnt Sienna (ground in water).....	2 ozs.

Mix, and then add 2 ozs. of alcohol.

28. Applying Mixture.—Apply the backing to the glass side of the plate, using an ordinary bristle paint brush for the purpose. Of course this must be done in the dark-room. A good way to perform the work is to lay the sensitized plate on a dark card. Fit narrow strips of cardboard (no thicker than the plate) around three edges of the plate. Allow for a slight play, so the plates will not fit too lightly. Glue these strips fast. Whenever it is desired to coat plates, place them in this form, face side down, and paint over the glass. The strips will keep the plate

from moving about. This backing will dry quickly and is easily removed.

29. **Black Paper Backing.**—Another very simple method, which may be used, is to cut the ordinary black paper, in which the plates are packed, the least bit smaller than the size of the plate being used. After cutting, spread glycerine evenly over one side of the paper, and then carefully squeegee it to the back of the plate. The glycerine will hold the black paper in place for a number of weeks, and by simply wetting it is easily removed. Care should be exercised that none of the glycerine gets on the film, or front of the plate. The same form may be used for holding the plate as recommended when painting the plate.

30. **Focusing.**—In photographing small rooms or well lighted interiors no trouble will be experienced, but sometimes where a large or dimly lighted place is to be photographed, and especially when a wide-angle lens is being employed, it is not so easy to secure a sharp focus on all parts of the room. When the front or foreground of the view is sharp, the distance, in the rear of the room, will be found to be quite a little out of focus. The focus should then be equalized by giving attention to the middle. Select a point between the middle of the view and the foreground and focus sharply on this point. Do this with the open lens, using no stop. This will throw the near foreground slightly out of focus, nearer the middle will be sharp, but the distance may be still out of focus. Then, stop down until the foreground is sharp, when the rear will be sufficiently sharp for all purposes.

31. **Arrangement.**—The arrangement of various objects in the room is of extreme importance; but, as previously stated, there are times when it is very desirable to leave the furniture and other objects in their original positions. This necessitates very careful attention being paid to the source of light and the effect of the light on the various objects, as a spotted effect is by all means to be avoided. Where it is possible to group the various objects

so that lights of the same value come together, it should be done.

32. **Concentrate Interest.**—Avoid dividing the interest evenly between two or more subjects. There should be one point that claims more attention than any other; this is usually in the strongest light, or embraces a greater amount of contrast in light and shade than any other portion of the picture space.

33. **Distance From Camera to Subject.**—No object should be so near the camera that its lower portion is cut off. The base of all objects should appear. In other words, no object should be cut off by the lower margin of the picture.

34. **Windows Included in View.**—Do not include more windows in the view than are absolutely necessary. When it is impossible to choose a favorable position and have the windows out of the angle of view, the curtains or blinds should be drawn while making the first three-quarters of the exposure; then, cap the lens, or close the shutter, raise the shades to the normal height and expose for the balance of the required time. In this way there will be little danger of halation and the resulting effect will be perfectly natural.

35. **Technical Detail.**—A stricter attention to technical detail is necessary with interior work than in landscape. It is quite essential to avoid all symmetrical or set arrangements, whether in a general interior view, or of some detailed portion of a room.

36. **Low Point of View.**—As a rule, nine out of every ten prints of interiors are ruined by insufficient foreground or floor being shown. It is advisable, therefore, to employ a low point of view, as the placing of the camera in such a position prevents the displeasing effect of a slanting floor. When photographing interiors where extremely heavy objects, such as large pillars in hallways, appear in the view, special care must be exercised to have a fair extent of flooring shown beneath them, to give a sense of support and balance.

37. **Introducing Figures.**—If figures are introduced in interior pictures, always give the subject, or subjects something to do, so the effect will not be unnatural and set.

38. **Location of Figures.**—Never have a figure appear near the edge of the picture facing outward. The figure should always face the center or toward the most important object in the picture space. Never place a figure in the exact center of the interior view. A location slightly to one side or the other of the center should be selected. Usually preference is given to the left side. When a figure is placed in the middle distance of the picture space, do not have a large object between the figure and the camera, as this would tend to make the figure appear small in comparison with the nearer objects.

39. **Dodging During Exposure.**—Sometimes a little dodging may be successfully resorted to by permitting the figures (which, of course, must be arranged in good light) to remain for the regular time required to get a good picture of them alone. When this time has expired have them step out of the picture and then give the balance of the exposure for the interior. The lens can be capped or the shutter closed while the figures are leaving the room. If much exposure is given, capping the lens will not be necessary, because if the subject moves out of the room quickly there will be no blurring. When subjects are to remain in the room only a portion of the time, care must be taken to arrange them in a position with some dark object as a background, or the effect will be spoiled and a ghost-like effect will show in the completed picture. *Always have a dark background behind the subject, under such circumstances.*

40. **Lighting.**—The lighting is governed by the conditions which exist in each individual case. It will be necessary to choose the point of view that gives the greatest amount of even illumination, and at the same time shows the most pleasing and attractive portion of the room. When the point of view has been selected, give careful consideration to the effect the light has on the individual pieces of

furniture, and other objects. Avoid spotty effects in lighting, and if the general effect seems to be spotty, the slight turning of a chair, or altering the position of the objectionable feature, might have much to do toward securing proper effect and a harmonious, even tone throughout the picture.

41. **Time of Day.**—Great difference may be made in the lighting of most interiors, by choosing the right time of day and proper weather conditions. The room being photographed should be on the shadow side of the house. This will give a more uniform lighting than could be ordinarily obtained if rays of strong sunlight were falling on the window. A room on the east side of the house should be photographed in the afternoon, a west room in the morning, etc. Better results will be secured if it is slightly cloudy out of doors, as the diffusion of light throughout the room will be much more uniform and the high-lights not so strong and accentuated.

42. **Diffused Light.**—Sometimes diffused light may be secured by pinning a single thickness of cheese-cloth over the window through which strong sunlight is admitted. As exposure is not made for the high-lights, strict attention must be paid to the shadows, and every effort made to soften the high-lights. Usually when doing this, the even illumination will give more light to the shadows, as the light, being more diffused, is evenly distributed throughout the room.

43. **Dark Walls and Furnishings.**—If the walls and general furnishings of the room are very dark, it will be necessary to pay more strict attention to the source of light and to the amount of diffusion given the light, than if the walls are of a light material, which would reflect a great deal of light to the shadows. It may be taken as a general rule, therefore, that in photographing dark interiors, the source of light must be diffused considerably more than when photographing interiors of light character. Of course, the required exposure will be increased many times, but as a rule the extreme length of necessary exposure is no detriment.

44. **Source of Light—Location.**—It is generally advisable to have the main source of light come from back of the camera. In this way strong shadows will be done away with and there will be little danger of crossed reflections on polished surfaces. It is specially advisable to have the light come from this direction, when the interior contains a considerable amount of dark furniture. In the case of light furnishings and light walls, if the source of illumination is directly back of the camera, a flat effect would result. Therefore, where the furnishings are of light description, and when it is desirable to have a certain amount of shadow and contrast appear to secure the necessary relief and atmosphere, the source of light should come from one side of the camera, rather than directly back of it. Of course the camera must not cast a shadow on the floor within the picture space.

45. **Lighting Figures.**—When figures are introduced and form the principal item of interest, special care must be exercised in proper facial lighting. If more than one figure is introduced, be very careful to have them grouped so there will be no confusion or division of interest between them. Such a condition would completely ruin the artistic quality of the picture.

46. **Detail Should Prevail.**—*There should be detail in all portions of an interior picture.* Smudges do not represent shadows and are entirely out of place in work of this class. Careful thought given to the general method of work and plenty of time devoted to judgment of conditions affecting exposure and lighting the scene, will invariably give satisfactory results.

47. **Exposure.**—There is probably more latitude in the exposure of interiors than in any other class of photographic work, yet one must be guided almost wholly by existing circumstances and conditions. One point is absolutely necessary—expose long enough to produce detail in the deepest shadows. This may require 30 seconds or 60 seconds, or even 2 minutes, and for extremely dark places one hour may not be too long an exposure. In

either case, should you over-expose a few seconds or a few minutes it will not be perceptible in the finished results.

48. **Exposure—Interiors Having Stained Glass Windows.**—When timing interiors having stained glass windows, the light diffused through the glass is usually of a yellow, or orange, shade and is practically non-actinic. The exposure must, therefore, be at least one-third longer than if the glass were clear or white.

49. **Exposure Depends on Varying Conditions.**—The color of the furniture, wall paper and carpets also plays an important part in the time to be given parlor interiors, sitting-rooms, etc., and must be timed according to the depth of color. When photographing dining-rooms with tables set, the time can be shortened, as all the surroundings are practically white, which permits shorter exposure. As conditions vary greatly no set rule can be laid down. There is one general guide, however, it is well to follow, which will give an approximately correct knowledge of the required exposure. As before stated, some interior views may be made by giving an exposure of only a few seconds, others require minutes, while still others consume hours, to secure a perfect register on the sensitive plate of all the detail in the deepest shadow. For the average exposure in the ordinary room the following method may be advantageously employed:

50. **Ascertaining the Exposure.**—Cover your head and camera with the focusing cloth, to exclude all light from the ground-glass excepting that which comes through the lens. Open the lens to the largest aperture and then remain under the cloth until the eyes become accustomed to the darkness, so you can see the image distinctly over the whole of the ground-glass screen. It is important that the eyes become perfectly accustomed to this light before making any attempt at judging the exposure. Therefore, without uncovering the head, with one hand placed upon the stops or diaphragm, stop down the lens by degrees until the plate is sharply focused. At this stage observe the strength of illumination on the ground-glass, as this will

serve as a guide to determine the exposure necessary. Better over than under-expose. In fact one should aim to expose fully. Bear in mind that where a long exposure is required, 40 seconds is only twice as much exposure as 20 seconds, and the giving of 30 seconds exposure would not materially cause over-exposure, if 20 seconds was the correct time to give.

Exposure Table for Interiors.

51. This table is based upon the use of a stop not smaller than f. 16 or U. S. 16. Where the next size smaller stop is used, two times the exposure must be given, so calculate accordingly. The plate used is the ordinary fast plate.

52. **White Walls and More Than One Window.**—Bright sunlight outside, 8 seconds; hazy sun, 20 seconds; cloudy bright, 40 seconds; cloudy dull, 1 minute and 20 seconds.

53. **White Walls and Only One Window.**—Bright sun outside, 12 seconds; hazy sun, 32 seconds; cloudy bright, 60 seconds; cloudy dull, 2 minutes.

54. **Medium Color Walls and Hangings and More Than One Window.**—Bright sun outside, 16 seconds; hazy sun, 40 seconds; cloudy bright, 80 seconds; cloudy dull, 2 minutes and 40 seconds.

55. **Medium Color Walls and Hangings and Only One Window.**—Bright sun outside, 24 seconds; hazy sun, 60 seconds; cloudy bright, 2 minutes; cloudy dull, 4 minutes.

56. **Dark Colored Walls and Hangings and More Than One Window.**—Bright sun outside, 40 seconds; hazy sun, 1 minute and 20 seconds; cloudy bright, 2 minutes and 40 seconds; cloudy dull, 5 minutes and 20 seconds.

57. **Dark Colored Walls and Hangings With But One Window.**—Bright sun outside, 1 minute and 20 seconds; hazy sun, 2 minutes and 40 seconds; cloudy bright, 5 minutes and 20 seconds; cloudy dull, 10 minutes and 40 seconds.

58. *This table is intended for rooms with windows receiving the direct light from the sky, but not with the sun shining on the windows.* Time of day, from three hours after sunrise until three hours before sunset. If earlier or later the time required will be longer.

59. **Under-Exposure.**—More failures are due to under-exposure of interiors than from any other cause. This is the case with beginners especially. They imagine that, with the sun shining outdoors, they can make almost a snap-shot indoors. Such is not the case, however, for, while a full-timed image would be obtained outdoors with a snap-shot, on a bright day, it must be remembered that one then has the benefit of unobstructed sunlight. In making exposures of interiors under similar light conditions, the work is performed with but a small fraction of the illumination that you had outdoors, for there all the light from the heavens was at your disposal, while here you have only the light admitted through window openings. The more windows, of course, the more light.

60. **Making Exposures.**—If your shutter is not automatic, learn to cap and uncap the lens quickly and without jarring the camera. With figures in a view it may be necessary to cap the lens or close the shutter, to allow them to step out of the picture, when you can again uncap, or open the shutter, for the remainder of the exposure. Shutters other than the automatic cannot be used for this purpose, because the necessary setting is apt to jar or slightly alter the position of the camera, so that when a second exposure is made a double image will be formed on the plate.

61. **Working in Confined Positions.**—If the camera is located in a position so confined that there is no room to draw the slide of the plate-holder, take a rule and measure the distance from the side of the camera to the obstruction. Then loosen the tripod screw and turn the camera around sufficiently to permit the drawing of the slide. Return the camera to its original position, adjusting it with the rule, and tighten the screw.

CHAPTER II.

Mathematical Method of Measuring Light.

62. **Judging Strength of Light.**—One must not judge the strength of light by the appearance of the light entering the window; on the contrary, estimate the effect of this light on the darkest portions of the room. These portions should be the guide, as you must *time* for the shadows, regardless of high-lights. The necessary exposure may be estimated by measuring the light and floor space in square feet. The following rule may be employed. While it is by no means accurate, yet it is sufficiently close to serve its purpose, and with it the necessary exposure can be quickly figured:

63. *First of all*, it is presumed that the sun is not shining through the windows of the room in which exposures are being made; also that the source of light is diffused—*i. e.*, the light employed enters the windows from the shady side of the building and, therefore, is not direct sunlight, nor does it approach the strength of direct sunlight. *Second*, consider how much space this source of light must illuminate. If, for example, the room you are to photograph is 12 by 18 feet, or 216 square feet (area of floor), and you have the full illumination from but one window, say 3 x 5 feet, or an opening 15 feet square, you would have to illuminate 216 square feet of floor through 15 feet of illumination space. In other words, 216 feet of floor space must be illuminated with 15-216ths; or, about 1-15th as much light as would be available if the picture was made outdoors in the shade. Therefore, if the same light conditions prevailed indoors as outdoors, you would naturally give an exposure of 15 times that which you would give outdoors; but, as the interior light conditions are not the same as those outdoors, the difference must be estimated.

64. **Estimating Strength of Light.**—For ordinary work in rooms with medium light walls and light furnishings, it is safe to estimate that the light outside is more than 8 times as strong as the light inside of the window. To prove this estimate, place a piece of proof paper on a medium-strength negative, in a printing frame, and place it outside of the window to print. Note the time it will require to print this proof to the proper depth. Then, take the same negative with another piece of proof paper, placing the frame on a table inside of the window. You will find it will require 8 times as long to print the proof inside as it did outside; consequently, we figure that the light is 8 times as strong outside of the window as it is inside.

65. So, if with a U. S. No. 16 stop you can make a full timed exposure in the shadow of the house, outdoors, in $\frac{1}{2}$ second, with the same stop and light conditions indoors, and with the object close to the window, the exposure should be 8 times as long, or 4 seconds. But, considering that one must illuminate the entire 216 feet of space with the 15 feet of window space, or about 15 times more space than the size of the window opening, you must give 15 times more exposure for the entire room than you would for an object close to the window, or 60 seconds.

66. **Rule.**—*Divide the amount of window space into the amount of floor space, and multiply the result by eight times the amount of exposure necessary for outdoor work in the shade. This will give you the amount of exposure required.*

67. **Actual Illuminating Space.**—First measure approximately the size of the window space used, or if more than one window is used combine the measurements of all. If a portion of the window is cut off with blinds, you must only consider the actual space supplying illumination, multiplying the width by the length of the window. For example: If you have two windows, each 3 x 5 feet, one of these windows would measure 15 feet; thus the two supply 30 square feet. This constitutes your illuminating space.

68. **Space to be Illuminated.**—If your room measures 12 by 18 feet, multiplying the width by the length gives

you 216 feet. This constitutes the floor space. If more than one room is admitted you must, of course, consider the size of the combined floor space, just the same as you did the combined window space. Divide the combined floor space (216 ft.) by the combined window space, (30 ft.) and the result of this (which is 7) you multiply by eight times the amount of exposure necessary for outdoor work in the shade (for all practical purposes you can calculate on $\frac{1}{2}$ second for bright weather and longer for dull weather), and the result (28 sec.) is the amount of your exposure necessary for the interior.

69. The above estimate is based on medium light wall and light furnishings. Where the walls are medium dark you must again double the exposure. If very dark give 4 times the exposure.

70. **Stops.**—The stops will range in the same order for interiors as exteriors. If with a No. 16 stop under the above conditions, 28 seconds exposure is sufficient for medium light walls, the next stop, U. S. 32, would require 2 times this exposure, or 56 seconds. For a No. 64 stop it would be correct to give 2 times the exposure required with a 32 stop, or 112 seconds, or approximately two minutes.

71. **Requirements.**—The principal requirements are, therefore, that you judge accurately the necessary exposure for outdoors with the same stop as you are using indoors. This supplies the factor by which to obtain measurements of the light for indoors. By this mathematical method of figuring you can judge fairly accurately the required exposure, but you should not rely entirely upon this rule; in fact, you should train the eye to measure the light by the appearance of the image upon the ground-glass. Combining the two, however, you have a good guide to follow, as the mathematical method will give you an approximate estimate, while your final judgment should be based upon the appearance of the image upon the ground-glass. These combined will serve well until you have had sufficient experience to judge the exposure by sight.

CHAPTER III.

Interior Photography.

Part II.

Developing—Examples.

72. **Development.**—Even though all other operations have been performed in the most careful manner, improper development may ruin what would otherwise be an excellent interior negative. The treatment in developing depends entirely upon the lighting, the amount of contrast and the depth of shadows; also, the strength of the high-lights in the view. Where a great amount of contrast prevails, development should be carried on in a soft working developer. When ordinary plates are used they should be started to develop in the normal developer. The formula for Universal Developing, given in Volume II, is recommended.

73. In addition to tray containing normal developer, in which all plates should be started to develop, provide an extra tray; pour into it a liberal quantity of developer which has been previously used—old developer—adding very little of the normal developer to it. If the image on the plate flashes up quickly on all parts of the plate at the same time, the plate is probably over-exposed. In this case, transfer it immediately to the old developer. This old developer contains a certain amount of bromide, released from plates previously developed with it, and will, therefore, retard the development. The plate will develop satisfactorily unless extremely over-exposed, in

which event it will develop flat. Under such conditions add to your normal developer from ten to fifteen drops of a 10% solution of bromide of potassium, concluding the developing in this bath. See instruction on "Developing Over-exposures," Volume II. Quite often a plate, after being treated in this way, is benefited by finally being placed in a normal developer which contains one-third the regular amount of water. This gives a developer stronger in pyro than the normal developer, which will build up the high-lights very quickly, giving more contrast.

74. In case a plate is under-exposed and develops slowly, with too much contrast, place it into a tray of plain water for ten minutes, away from the light. Then conclude developing in the normal developer, which has been diluted with double the amount of water. See instruction on "Developing Under-timed Plates," Volume II.

75. **Developing Specially Prepared Plates.**—If the plate you are about to develop is backed, carefully remove the backing with a wet sponge, and proceed with the developing as already described. If paper backing is used it need not be removed before developing; the plate can be developed in the ordinary way. The backing may be removed when it becomes soft in the developer. If the plate is non-halation, it must be carried further in the developing than the ordinary or backed plate, as it will fix out considerably more. Use a rather dilute developer on these double coated plates, so that development can be prolonged sufficiently to affect the lower emulsion, which will take about double the usual time. After development, rinse for a few minutes in fresh water and fix in the usual way, leaving the plates in the bath until entirely fixed, which, owing to the thickness of the film, will take twice the time of a single coated plate. If the plate is taken from the bath before it is thoroughly fixed it will very likely become stained. The final washing must be thorough. Most failures are due to under-developing, the negatives produced being extremely thin, full of detail, with little or no printing quality. When using Iso or Orthochromatic non-halation



PORTRAIT OF CHILD

STUDY No. 4—See Page 401

CHAS. E. FAIRMAN

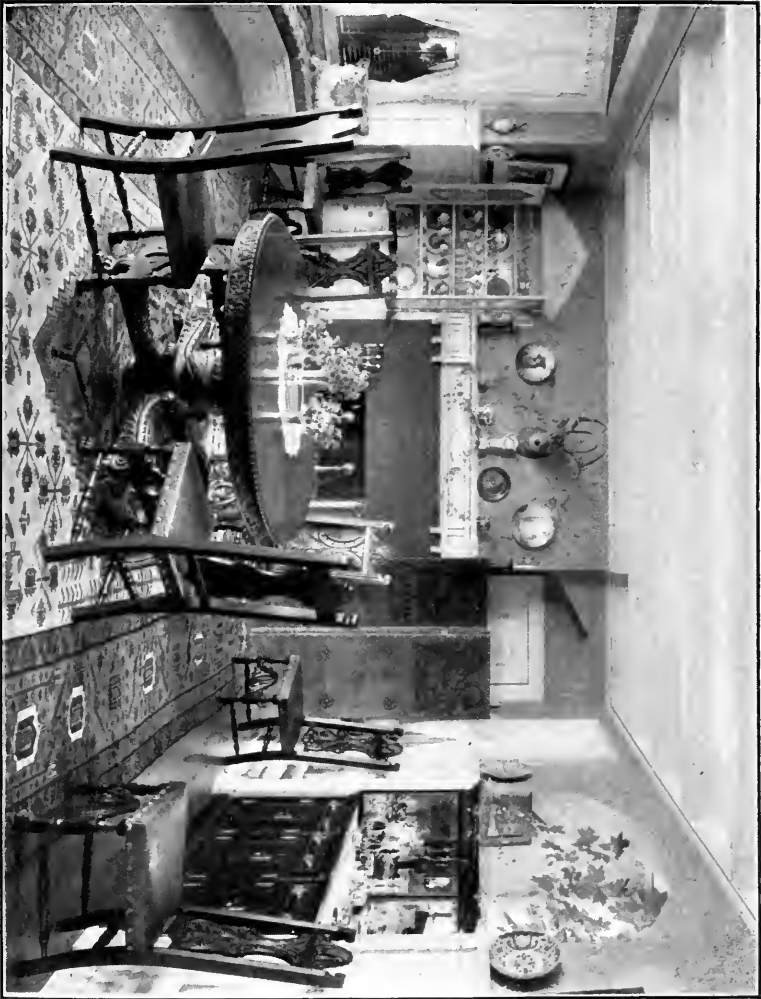

Illustration No. 1

Simply Arranged Dining-room

See Paragraph No. 78

plates, they may be developed in normal developer according to formula given for Universal Developing, but excellent results can be obtained by proceeding in the following manner:

76. Of the regular stock solution of sodas (formula given for Universal Developing), take 1 ounce of Stock Solution No. 3 (Sulphite of Soda) and 1 ounce of Stock Solution No. 4 (Carbonate of Soda) adding to this 6 ounces of water, making in all 8 ounces of solution. Mix these solutions thoroughly; then divide into two parts, 4 ounces in one graduate and 4 ounces in another. To one of these graduates add 2 ounces of Stock Solution No. 2 (regular Pyro solution). Start your development of the color sensitive plate in this solution. From time to time add from second graduate a little of the sodas which have already been prepared. In this way the high-lights will be kept ahead of the shadows throughout the development. Continue to add more of the sodas as you develop until all the detail necessary is secured. This method is useful only where full exposure has been given, as under-exposure will not produce satisfactory results.

77. As these plates are extremely sensitive to all colors of light—even your dark-room lamp—they should be carefully handled in the dark-room without exposure to any light. During development, cover the dark-room light with a couple of extra pieces of post-office paper. Do not examine the negative too often, and not at all until it is nearly developed; then it should be briefly examined by extremely dim ruby light. By carefully adding the sodas, it will be found, when all the detail necessary has been secured, the plate will be fully developed, having been built up gradually as it developed.

78. **Three Examples.**—Illustration No. 1 shows a very simply arranged dining-room, one that may be found in the average home. The lens used in making this interior was a Bausch & Lomb-Zeiss, having a focal length of 14 inches; using a stop f. 64, at 10 A. M., with bright sunshine outdoors. An exposure of 10 minutes was necessary to

secure perfect detail in all portions of the room, A Standard Orthochromatic plate was used; the developing agent was Pyro.

79. Notice carefully the general composition. More of the right-hand side of the room is shown than of the left, which assists in breaking uniformity, a most undesirable factor. Never attempt to show as much of one side of the room as of the other. In the bay-window the blinds were all thrown open, with the exception of the one included in the view. The opaque curtains were raised full height, but the lace curtains were brought together over the windows, to evenly diffuse the light. Advantage was taken of a window at the rear of the camera, which, with its full light, destroyed the shadows which otherwise would have resulted if only the side-light from the bay-window had been employed. The door at the further end of the room, on the right hand side, being painted white, would have been an intruding feature had it not been partly hidden by the screen which was purposely placed in front of it.

80. Another point, which is one of the most vital in the making of interior views, is that no object should be so close to the camera as to be partly cut off by the bottom of the picture. Many times, however, this is impossible to avoid. The bases of all objects, chairs, tables, etc., should appear in the picture—they must have a support upon which to rest. The development of Illustration No. 1 was carried to exactly the right stage, all detail being preserved in even the highest points of light.

81. An exceptionally difficult subject to photograph is shown in Illustration No. 2. This dining-room, including ceiling, floor and walls, is finished in dark wood. To the left is a large fire-place finished in a light colored tiling. The furniture is all dark and very delicately carved. The table is spread with white linen. To secure detail throughout in both shadows and high-lights, was no easy task. Employing a Standard Orthochromatic plate, a wide-angle anastigmat lens of 7 inch focus, and using stop f. 64, an exposure of 1 hour and 10 minutes was given. The day



Illustration No. 2

A Dining-Room

See Paragraph No. 81



Illustration No. 3

General Interior View

See Paragraph No. 82

was very dull and the exposure commenced at 4 P. M. The only source of light employed was that coming from behind the camera. If a side-light of any kind had been used it would have been almost an impossibility to have secured detail in the shadows which would have been formed. This is such a difficult subject that the reproduction does not do the original full justice. In making the half-tone some of the detail has been lost in the high-lights, which makes them appear a trifle chalky.

82. An entirely different type of interior is shown in Illustration No. 3. The floor and ceiling were dark, the walls being a medium tone. The light employed came from a window located a little to the left of the camera. The room which is seen through the archway was illuminated from a window to the left, as will be observed by the shadow cast on the floor by the circular chair. The day on which this negative was made was quite dull, yet it required but 20 minutes exposure, at 2 P. M., using a wide-angle anastigmat lens of 7 inch focus, stop f. 64, and a Standard Orthochromatic plate.

83. Notice that the camera was turned enough to the right to avoid having the chandelier come in the middle of the picture space. An error commonly made in photographing interiors is to have the chandelier, or the highest point of attraction, come in the center of the picture. This is a serious mistake. Then, too, the corner of a room should not divide the picture into two parts. The camera should be turned so that the corner will come either to one side or the other of the center.

84. By comparing these three illustrations and studying them carefully, you should be able to apply the principles to your own practice work.

85. **Practice Work.**—For first experiments select an interior view of any convenient room—the office, studio, or any living-room in the home. The dining-room is a good room to select, if it is large enough. However, the simplest interiors to make are, usually, connecting rooms. For example, the library and living-room connected by

either an archway or double doors. In such cases the camera can usually be satisfactorily arranged in the doorway of a third room, or in one corner of one of the rooms. When photographing a suite of rooms, the first room usually looks better taken from a diagonal position, or from one side, as better lines are thereby imparted to the view of the room. Observe the instruction regarding the illumination, also the general arrangement of furnishings. Generally furnishings are arranged to be viewed from the most conspicuous point. One should endeavor to photograph a room from this same point, thus practically reproducing the room with furnishings as it was intended to appear by the decorator.

86. **Focusing.**—When focusing, see that the middle and front are sharp. The middle may be sharper than the foreground. If the foreground is slightly out of focus, carefully divide the focus between the front and middle, making the middle, however, the sharper. If the distance is not sharp, use a stop one size smaller than is necessary to sharpen the foreground and middle. This will give sufficient sharpness in the distance to produce satisfactory results.

87. **Exposure.**—Give sufficient exposure to fully time the most dense shadows. Do not fear over-exposure, as great latitude is allowable in the time to be given interior views.

88. Where a dining-room is to be photographed, the sideboard, table and chairs usually appear large, while the room seems small, and it is almost impossible to make such a view without pointing the camera directly toward the window. The first step is to place the camera in position. Endeavor to show one end and two sides of the room. If this is impossible, show a corner, one end, and almost all of one side. Remember, objects nearest the camera will be magnified in size. A child's small high-chair, if placed near the foreground, may in this way be made to appear like an arm-chair.

89. *Remember*, never place a piece of furniture closer

to the camera than the portion of the floor showing on the ground-glass. Carefully turn the furniture so that you will produce most artistic lines and secure the best point of view. At the same time, bear in mind that you must not spoil the effect of the home surroundings. While it is permissible to move a chair, couch or table, it is always advisable to have grandfather's, or baby's chair in their accustomed places.

90. After other furniture has been placed in position, carefully consider the table, upon which, most likely, will be spread a white linen cloth, and a display of the family silver, chinaware, etc. Also carefully view the glass and chinaware on the sideboard and examine the pictures on the wall. In all cases be sure to see that there are no bad reflections.

91. While an ordinary plate can be used, either a non-halation or a backed plate will give better results, especially if the window is included in the angle of view. But, for your first experiments, we advise the use of ordinary fast plates, as they are easier to manipulate. After you have had some experience with plates of this class, the special plates should be employed, as you will then be able to manipulate them more intelligently.

92. The next point for consideration is the source of light, and also the light which enters the windows included in the picture space. Experiment by drawing the shades completely on the window toward which the camera is pointed. You may also find it necessary to partially draw some of the other shades. If there are bad reflections, they can often be overcome in this way. Remember, you should, in most all cases, endeavor to have the source of light come from behind the camera, as proper high-lights without deep shadows will thus be obtained, and reflections done away with. However, if the interior of the room is extremely light, such a source of illumination would tend to produce flatness. For that reason the light should enter in greater volume at the side of the camera than from the rear.

93. As stated in the lesson proper, if there are several

windows, some of which must be shown, it will be advisable to draw all shades or blinds, except those necessary to give sufficient light for exposure. When the principal exposure has been made, with all of the shades coming within the angle of view drawn, close the shutter; then raise the shades and again expose for a second or two. In this way more illumination will be secured, resulting in added detail in the densest shadows; while the windows will not show that the blinds have been drawn at all, and there will be practically no halation. Sometimes opening the lens wide and exposing for a few moments will supply detail and improve the general effect. But this must be done cautiously or the camera will be moved, causing a double image in the picture.

94. After everything has been arranged satisfactorily and the image carefully focused, set the shutter, insert the plate-holder, draw the slide, and, again viewing the scene to be sure that everything is in the proper place, make the exposure.

95. Proof prints should be made from all negatives and filed in the proof-book or proof-file. On the back of these proofs make notes, of the lens used, stop used, exposure given, etc., including all data regarding the important features governing the method in which you proceeded to make the negatives. This data is extremely important, as it will furnish you with valuable reference material for future work.

CHAPTER IV.

Interior Photography.

Part III.

Controlling Halation by Special Development.

96. **Admitting Windows Into the View.**—The admission of windows into the view frequently enhances the appearance of a room, giving it a more natural and cheerful appearance. The most pleasing interiors are those wherein some windows are shown in the picture. This can be successfully accomplished if the proper methods are employed for the exposure and development of the plate.

97. An ordinary plate may be employed, but a non-halation, or backed plate, would further enhance the results. Even with specially prepared plates, however, if you were to expose and develop in the ordinary way, you would meet with failures. But, by following a special method of exposure and development excellent results may be secured and halation avoided.

98. **Time of Day to Make Interiors.**—Always make exposures when the light is most strong and evenly distributed. Rooms having windows facing north are best photographed at the noon hour; exposures of those facing the east are better if made in the afternoon. A more subdued light throughout the room is obtainable at this time than could be secured in the forenoon. Rooms facing west photograph best in the morning, or toward noontime. In fact, around the noon hour presents the best time for all interiors, as the sun being higher at this time, supplies more

even illumination. By observing the light at various hours in the day, you can determine when the strongest light is to be obtained in the room to be photographed.

99. **Sun Shining on Windows.**—If it is necessary to make an exposure when the sun is shining through the windows, subdue the light on the windows supplying the illumination, by tacking cheese-cloth, or white muslin, over the outside of the window. This will avoid harsh highlights and dense shadows, because the developed plate will be exactly as the room appears. If the light is quite evenly distributed the negative will produce this result; if the lighting is contrasty the results will also be contrasty. If you cannot diffuse the sunlight in this way, and must make the exposure with the sun shining in the window, at least do not place the camera so the sun will shine toward it. Place the camera so the sun will light the rear of the view. This direction of light will supply more illumination to the shadows.

100. **Windows in View.**—When windows are to appear in the general view, raise the shades, leaving only the lace curtains at the windows, thus admitting the maximum amount of desirable light into the room. Of course the angle of light should lead from you. It must be understood that in admitting windows into the view the main source of light should be received from windows other than those appearing in the view, because the inside of the windows must receive some illumination. Then, too, if the only source of light came from the windows in the view, the light would throw shadows toward the view point, which, reproduced without proper detail, would appear smudgy. For this reason the shadows must be illuminated either by a window, or other source of light, back of, or at the side of, the camera.

101. **Selection of View Point.**—To properly photograph a room in which windows are to be admitted into the view, the view point should be selected where the illumination comes from the back, or side of the camera, and not from windows appearing in the view.



LADY AT WINDOW

STUDY No. 5—See Page 402

EVA GODLEY ROLFE





Ordinary Plate—Special Development



Non-Halation Plate—Ordinary Development

Illustration No. 4

See Paragraph No. 102

AVOIDING HALATION

102. **Exposure.**—With the view point selected, proceed to obtain a sharp focus, stopping down merely enough to give good definition; then expose at least four times longer than would ordinarily be necessary. For example, if 30 seconds exposure would give you full detail in the deepest shadows, using the ordinary method of developing, for this method give four times that amount, or two minutes. Or, if one minute is required for normal exposures, give four minutes for this method. Develop the plate according to instruction for *Special Developing* given in Chapter XIII, Volume II. (See Illustration No. 4.)

103. **Give Full Exposure.**—The success of this class of work depends entirely upon the exposure. The plate must be fully timed. If you are in doubt as to the necessary exposure, time rather on the side of over than under-exposure. Such wide latitude is allowable in the development that any reasonable amount of over-exposure can be easily overcome.

104. **Direction of Light.**—According to this method, you may select any view point best suited to the view, admitting as many windows as desired. The angle of the sunlight, however, must not be directed towards the camera, but should lead into the view, away from the camera. If directed toward the camera you would be photographing against the shadows, which will give you a smudgy effect. *The illumination should fall upon the subject, not upon the camera.* The angle of light travels straight ahead and all objects in its path are illuminated. Those back of it are in shadow.

105. **Illuminating Shadows.**—The shadows should be illuminated through windows outside of the view, which do not supply the principal source of light. Therefore, if a view is to be made from any particular point, see that the light is directed from that point of the view and not toward it.

106. **Even Illumination.**—By observing the light at different hours of the day, in any room, you will notice that the entire room is more evenly illuminated at some hours than at others. Then, again, you will observe that one end

of a room is better illuminated when the angle of light leads towards that particular end; also, that this same end, or corner, of the room is less illuminated when the angle of light is reversed. These important matters, which persons of little experience are quite apt to overlook, have a vital bearing on the making of satisfactory pictures.

107. The matter of direction of light does not pertain alone to cases where windows are admitted into the view, but even where they are excluded. The direction of the light supplying the illumination is the same, and has exactly the same effect whether windows are admitted into the view or not.

108. **Theory of Special Method of Developing.**—By the Special Method of Developing it will be learned, by reference to that lesson in Chapter XIII, Volume II, that we calculate on ample exposure to fully time the most dense shadows. You will learn that we register upon the plate all the exposure necessary for detail in these shadows, at the same time being aware that the high-lights (the windows) are many times over-exposed; so it is necessary to hold back the high-lights and develop the shadows.

109. **Use of Alkali.**—Carbonate of Soda opens the pores and permits Pyro to penetrate the film. Without some alkali the Pyro will not act. If the shadows can be developed along with the high-lights, exactly what you see in the view can be retained, which is the object of this developer. But, the developer is helpless without sufficient exposure. Combining the two will control the high-lights, as only sufficient alkali (the detail-producing chemical) is used to develop the shadows. The amount employed is not enough to build up, or clog, the high-lights, so they are held down until the shadows are fully developed. A few drops of alkali should be added from time to time, until the entire plate is developed.

110. **The Result.**—When the shadows are clear and crisp—full of detail—and are registered exactly as viewed on the ground-glass, then you have a true record. It will be found that this plate is free from all halation, and that

even in the strongest high-lights the lace curtains on the windows show every line of design as soft as though an exposure had been made on them alone.

111. **Practice Work.**—It is advisable, for the benefit of the experience you will derive from this experiment, that you expose one plate in the ordinary way and develop it in normal developer, using the *Universal Developing* formula. Expose another plate, giving four times the exposure, and develop according to the methods for *Special Development*. Compare the results, which should convince you as to the value of this method of treatment. For all your worthy work, where strong lights, such as caused by admitting windows into interiors, are to be contended with, use this method. Make proof prints from both of the above plates mentioned, noting all necessary data on the back of each, and file in the proof file for future reference.

112. **Note.**—While non-halation, or orthochromatic, plates will give better results in this work than the ordinary fast plate, for first experiments use the ordinary plates, as they are more easily judged in the development. Other experiments may be made later with the special plates, which, if properly manipulated will give still better results. However, use ordinary plates for first work.

CHAPTER V.

Difficulties—Interior Photography.

113. **Securing Even Illumination.**—If the light is all taken from one side of a room, to fully illuminate the far distant portions, the angle of the light must lead toward those portions and away from the camera. The camera should always be placed with the source of light back of it, and leading into the picture. In this way the light traveling forward will carry the illumination ahead of it, while, should you work in the opposite direction, you will be working against the light and, in consequence, be photographing the shadow side of objects instead of the high-lights.

114. Where windows are admitted into the view, have other sources of illumination to light the remainder of the room, also to offset the strong light coming from the window which has been admitted into the scene. Under the latter conditions draw the shade on the window admitted into the view, for a portion of the exposure; then raise the shade for the remaining time, and the window will show in the view without a blur, and you will also have little trouble with halation.

115. **Obtaining a General View of the Room.**—When using a long focus rectilinear lens, if the room is small it will be a difficult matter to photograph the greater portion of it; therefore, select only a section of the room—one corner and one side, for instance. Where a wide-angle lens is employed, it is often possible to show both sides and one end of the room. Be careful, in finally adjusting the camera, not to show too much ceiling or floor. Try to produce proper balance, and always be careful that vertical lines, window and door casings are perfectly true.

116. **Arranging the Furniture.**—Make no attempt to change the arrangement of the furniture according to any set plan. Place each piece in a natural position. If trouble is experienced with white spots, caused by the reflection of light on polished furniture, it is better to turn the offending chair or table a little to one side or the other, to overcome these reflections. Usually, these will give little trouble if there is no sunlight coming through the windows, for then a general diffusion of light is obtained

throughout the room. Never have furniture close to the camera. If the room is small, it is better to remove any piece of furniture that may be directly in front of the lens.

117. **Focusing.**—As the light indoors is so much weaker than outside, naturally the image will not appear very strong upon the ground-glass. You should always focus without a stop. Cover the head and the camera with thick focusing cloth, through which no light can enter; then, with the left hand draw the ends of the cloth under your chin, so no light other than that which comes through the lens will be admitted. Adjust the focus and stop down sufficiently to give good definition.

118. **Judging Proper Exposure.**—This is one of the most difficult features of interior photography, which practice alone will enable you to learn to judge properly. The appearance of the image on the ground-glass is the only positive guide. If it is bright, you will understand that less exposure is necessary than if it were dull and dim. The amount of dullness determines the length of exposure. If you will observe the different rules for the approximate judging of proper exposure given in this instruction, and will try them out carefully, the experience should materially aid you in judging necessary exposure. Keep a careful memorandum of all exposures of first work, accurately noting time of day, conditions of light, color of objects you are photographing, etc. When developing the plate, if you find the time has been misjudged, it being under-exposed, the next time you make an exposure under like conditions govern yourself accordingly and time longer. There is little danger of over-exposure in interior photography, so have no fear of over-timing. If difficulty is encountered in giving sufficient exposure, try to overtime, when it is quite certain a properly exposed plate will be the result.

119. **Overcoming Halation.**—The cause of halation is fully explained in this lesson. The use of non-halation plates will aid in overcoming this difficulty. A good plan is to over-expose and then develop according to instructions given in lesson on "Special Development," in Volume II.

120. **Obtaining Detail in the Shadows.**—This you can only hope to obtain by giving full exposure. (Of course the angle of the source of light must be directed towards the shadows). If a plate is under-exposed, treat it as such in the development. This will aid in the production of detail. Another excellent plan is to breathe on the shadow portions of the plate during development. The warm breath will cause the developer to act more readily. Another method is to lay the fingers on the shadow portions, for a few moments at a time, during development. The warmth from the hand will aid the developer to act in producing detail. Usually,

however, it is difficult to overcome lack of detail in shadows in any other way than by giving full exposure.

121. Plate Developing Contrasty.—Due to under-exposure. The shadows have not been sufficiently exposed to give softness. Always bear in mind, that the stronger the high-lights the more deep and dense are the shadows; therefore, time sufficiently to overcome this contrast, using diluted developer—thus softness will be produced.

122. Plate Fogging During Development.—If the camera is pointed directly into the window, toward the source of light, the illumination will be likely to reflect into the lens and cause fog. Non-halation plates will partially overcome this, but never photograph an interior, or any other object, with the light facing the instrument. On the contrary, locate the camera so that the light will fall upon the object being photographed, making the picture from the high-light side, so that no shadows will appear in the foreground. Over-exposure may also fog the plate, if the over-exposure is excessive. The image will flash up in the developer under such circumstances. If old developer is at hand, place the plate in it at once. If you have no old developer, add from 10 to 20 drops of Bromide to the normal bath, and conclude the development. Carry the plate a little farther than required for good printing, and after fixing reduce with Red Prussiate of Potash. It is advisable to add two drops of Bromide to the developer for all interiors. This will prevent fog and permit of long development.

123. Thin Negatives, Full of Detail But With No Printing Quality, When Using Non-Halation Plates.—This simply indicates under-development. Non-halation plates will fix out more than the ordinary plate. It is also advisable to develop them in diluted developer requiring a longer time for development. Therefore, develop them considerably further. It is much better to over-develop and reduce, if necessary (according to instructions given in lesson on Reducing), than to under-develop.

CHAPTER VI.

At-Home Portraiture With Home Surroundings.

124. **Introduction.**—The making of portraits in the home is by no means a difficult task, if one proceeds in a careful manner and without any attempt at haste. Attention must be given to each and every item included in the picture space, as it is essential that the composition be such as to produce a pleasing effect. There must be harmony throughout the scene; so before attempting to make a picture decide which is the most important item of interest. When this has been done, all other items must be kept subordinate, their functions being to add to, rather than detract from, the principal subject.

125. **Light.**—While, ordinarily, rooms with a northern exposure are preferred for portraits amid home surroundings, more strong and bold results may be obtained when the sunlight enters the windows, as you have far stronger illumination, which is carried farther into the room. This permits of working in any part of the room desired, and yet have plenty of light. Where the sunlight does not extend into the room sufficiently to show in the picture space, the windows will not need to be screened other than, perhaps, to allow the lace curtains (providing they are white) to remain on the windows undisturbed. If the curtains are of an ecru color they are apt to exclude too much light, and, therefore, should be drawn to one side or removed from the windows entirely. Should the sunlight extend into the room too far, so as to be included in the picture space, tack a sheet of white muslin over the window. This will diffuse and give a better distribution of the strong light throughout the room, allowing of reason-

ably rapid exposures being made. In many instances, with the light in this condition, exposures can be made in less than one second; much depending, of course, on the surroundings and the speed of the lens employed.

126. **Control of Light.**—Proper control of the light has much to do with concentrating interest on the principal subject, or subjects, the less important items being kept in shadow to a greater or less extent. The turning of a chair, or a slight diffusion of the light, may effectively do away with reflected light on polished surfaces of furniture, and also obscure objectionable objects.

127. **Value of At-Home Portraits.**—When rightly handled there is no field of photographic work more remunerative or interesting than the making of portraits in the home, amid home surroundings. There is hardly a family that would not appreciate having portraits made at home, with the general furnishing of the interior as accessories. To relatives and friends such pictures not only show likenesses of individuals, but also give an excellent idea of their home.

128. For some unknown reason comparatively few photographers have attempted this class of work, yet those who have taken up this important branch are meeting with most gratifying success, photographically and financially. As a rule, higher prices are paid for At-home pictures than for those made in the studio. As there is no rent to pay, no accessories or elaborate outfit to purchase, the expenses of the home portrait artist are very much less than those of the regular studio photographer. Thus, the profits are vastly greater. The field is absolutely unlimited.

129. If you will carefully follow the suggestions and instructions which follow, absolutely no reason exists why you should not master this phase of the work and be able to produce most excellent results.

130. **Principal Considerations.**—The *first* and most important consideration in making pictures amid home surroundings is proper illumination. The room and accessories desired in the view should be well illuminated.





Illustration No. 6

At-home Portraiture with Home Surroundings

Second, the subject or subjects should be placed in a position where they will receive the strongest light. Whenever possible, they should face the source of light sufficiently to supply lights and shadows to the face or faces. *Third*, the subject should not occupy the center of the picture space, but must always be placed a little to one side. *Fourth*, the surroundings must be in keeping with the character of the subject, or the subject must be dressed to conform with the surroundings. The finished picture should truthfully represent the individuality of the subjects.

131. In Illustration No. 5 is presented a picture of a business man in his private office. The picture tells its own story. The surroundings indicate a private office. The desk is one likely to be found in a well furnished private office. Such an office is seldom furnished with a large roll-top desk, having an array of papers and books surrounding it, neither is there likely to be a typewriter in the room. On the contrary, such an office should present a quiet appearance—a place where the occupant may quietly plan and lay out work and give private counsels without interruption. This picture well portrays the character of the man himself. The expression is truthful, the pose characteristic. Observe the light as it falls upon the face in true Rembrandt style, which assists in bringing forth the real individuality of the subject. Observe the excellent balance to this picture. To the right we have the desk and the figure. While the lines of the figure run at an angle through the picture, the face is sufficiently to one side of the view to give it prominence. The chair to the left and the pictures on the wall balance the make-up of the entire picture. This photograph was made in a room 14 x 18 feet, with the subject and desk placed almost in the center of the room. One window supplied all the illumination.

132. In Illustration No. 6, Fig. A, is represented a group picture amid home surroundings. While the group is arranged some distance from the light, still the illumination is of sufficient strength to fully light the entire group

as well as the surroundings. Observe the group arrangement and its conformity with the furnishings and surroundings. The picture balance is excellent; the grouped subjects occupying a position to the right, the space to the left being balanced by the small table. Observe that instead of the chandelier holding a prominent position in the center of the room, it is inconspicuously located to the left. Also, observe how the view was executed at right-angles to the light, thus supplying shadows to accentuate the high-lights. To have worked at an angle with the light, or, in other words, with the light directly back of the camera, would have produced a very flat effect.

133. The following are the conditions under which the picture was made: The strongest light came from three windows situated at the end of the room, opposite the group. The shadows were slightly illuminated by light coming through folding doors, which were almost at right angles with the group. The windows supplying the strongest light had the shades drawn down about half way. This was done in order that the reflection of light would not be too strong on the fireplace back of the group.

134. In arranging the subjects for this group, the point near the fireplace was selected to add coziness and home atmosphere to the picture. The child leaning on the mother's knee, observing attentively the pictures being described, and the third subject sitting on the settee, apparently listening to the description, assist in carrying out the story of the picture. While the group is sharp, it is not wiry, yet the surroundings, it will be observed, are slightly diffused and out of focus, supplying atmosphere. While there are no great contrasts, high-lights and shadows are present throughout the arrangement. The camera was placed 11 feet from the subject, between folding doors, being pointed toward the group at a slight angle. The exposure was made on a bright clear day, at 3 o'clock in the afternoon. The lens used was a Goerz; stop, U. S. 4; exposure, 4 seconds.

135. In Illustration No. 6, Fig. B, we present a photo-



Illustration No. 7
Special Examples of At-home Portraiture by Henry Havelock Pierce
See Paragraph No. 136



graphic shadow portrait, made in the bay window of a home. The illumination was obtained from the bay window, the camera being directed toward the source of light. The subject seated to the right, in the large chair, makes up one end of the picture, while the balance is obtained with the jardiniere and the dark space between the windows at the left. The subject was posed near the center of the middle window, at a distance of two feet from it. The camera was placed about 5 feet from the subject, aimed directly toward the window. The strongest light—actual sunlight—just touched the window at the extreme left of the picture, with a little of the illumination slightly falling upon the jardiniere. The sunlight produced the strong light on the cheek. A Goerz lens was used, with stop U. S. 4; exposure 3 seconds. The plate employed was "Seed 26 X," the negative being developed with Pyro.

136. Observe in Illustration No. 6, Figs. C and D, that quite a strong light is falling upon the back of the gentleman's head. Both of these pictures were made under identically the same light conditions—only one window supplied the illumination for the room. For this reason the lace curtains were arranged to afford sufficient diffusion to supply general illumination throughout the picture space. The two figures occupying the principal position to the right of the picture space are balanced by the sofa pillow on the stool at the left. The wall decorations, being simple, do not detract from the general appearance of the room, but give a fair idea of the surroundings. The pictures being made in a very small room accounts somewhat for their being crowded. More particularly is this the case in Figure D than in Figure C. Trimming of the picture has had much to do with this feature. The upper picture in Illustration No. 7 is another excellent example of *At-home Portraiture*.

137. **Window Portraits.**—Very interesting *At-home* portraits may be made close to a window. In all such cases a portion of the window should be included in the picture space. Ordinary lace curtains supply sufficient diffusion

of light to give roundness to the portrait. The subject should be placed far enough away from the window to illuminate the front of the face. Locate the camera almost on a line with the window, but a trifle further away from the wall than the subject. Any article of furniture may be employed; a large chair, settee, or sofa filled with pillows make good accessories. The walls of the room will serve as a background. The best results are obtained with window photographs when the sun is not shining on the window, as then there is more even illumination and the high-lights are not harsh. See Illustration No. 8, which shows good examples of window portraiture. The largest possible opening should be employed. Two or three seconds exposure will be sufficient. The plate should be developed in normal developer. The *Universal Developer* given in Volume II is especially recommended for this work.

138. **Practice Work.**—For first work select a well lighted room, and one or two subjects. Have them assume natural, easy, careless positions in a portion of the room where the light conditions are best for the work. Place them so that the light will fall upon one side of the face. Place the camera so as to get either a broad or a shadow lighting, according to preference. If a window is admitted into the view, show only a portion of it, and then work against the light; or, in other words, on the shadow side of the subject. Work as far from your subjects as possible to admit as much of the room as is desirable. Be sure to place subjects so they will occupy one end of the picture, having the other end broken with some small piece of furniture, or other object, to balance the picture space.

139. Focus on the principal subjects, regardless of furniture and surroundings. Stop down only enough to give clear definition to the figures introduced in the picture. If clear definition can be had without diaphragming the lens, so much the better, as the larger the stop employed the shorter the exposure can be made.

140. Be careful to shield the lens from cross lights. Should there be lights reflecting upon the lens, shield it

with the slide of the plate-holder, with your hat, or anything that will obstruct direct light falling on the lens. Of course, be careful that the shield is not placed between the lens and the view. The best protection to the lens is to prepare a cone to fit over the lens barrel, as is described further along in this volume.

141. When ready for the exposure, make two negatives of the same view, carefully developing them, one at a time. In the development of your second plate be guided entirely by the results of the first. Make proofs from both negatives, noting on the back of each all data connected with the production of the results, and preserve them in your proof-file for future reference.

CHAPTER VII

Difficulties—At-Home Portraiture With Home Surroundings.

142. **Illuminating the Subject.**—While this is one of the chief obstacles to overcome when making portraits amid home surroundings, yet the average illumination in residences is considerably more diffused, and consequently, stronger, than one realizes. Where a large room has but a small amount of illumination, work near the window. It will even do no harm to admit a portion of the window in the view. Frequently the picture value is improved by admitting a large portion of the window, and under such conditions you get all the light you want.

143. **Obtaining Real Effect of Home Surroundings.**—Where a large expanse of room surrounding the subject is required, work as far distant from the subject as possible. For that work a short focus lens should be employed. When photographing in crowded quarters, small negatives should be made by employing a small camera. If larger prints are wanted, negatives may be enlarged. With a small camera you can generally cover more space than with the larger instruments usually employed for this class of work.

144. **General Appearance Flat on the Ground-Glass.**—This will be the case when working with the light back of the camera, the source of light falling directly in front of the subjects, thus supplying no shadows. For portraits always work across the light, with the subjects placed in such a position as to supply shadows and high-lights.

145. **The Resulting Picture Flat.**—If the lighting is correct, this is evidently caused from under-development. Pictures taken in the interior of a home should be carried to full strength in the development. Owing to the fact that the plate develops slowly, one is apt to misjudge the strength of the negative and remove the plate from the developer before it is completely developed. A little practice will enable anyone to judge very accurately the depth of development necessary.

146. **Results Contrasty.**—Usually due to under-exposure.

Where the shadows are heavy, expose longer. Remember, always expose for the shadows, paying no attention whatever to the high-lights. When the shadows are fully timed the plate will develop with proper value, showing the high-lights and shadows in the same relation as they appeared on the ground-glass. It is advisable, when developing negatives made amid home surroundings, especially where the window is included in the view and full exposure has been given, to apply a normal developer with one or two drops of Bromide added. The very small amount of Bromide will prevent fog, so the plate will develop clear and crisp. Should the plate show signs of contrast, dilute the developer with an equal amount of water. The two drops of Bromide added will not cause this contrast, as that is not enough to produce such a result. If more than that amount were added it would restrain the developing and produce contrast. This is not the intention in adding Bromide, so the amount used should not be more than one or two drops of a 10% solution.

CHAPTER VIII

At-Home Portraiture.

Part I.

Introduction.

147. **Money-Making Opportunities.**—The first portraits made by the light of an ordinary home window were undertaken by the amateur, who attempted to secure the likeness of the various members of the family. Usual opinions on the results were, at that time, anything but polite, but with unflinching persistence the amateur has made himself a master of this phase of photography, and opened the eyes of professionals to the money-making opportunities in the field of At-home portraiture. In many cases the studio is receiving secondary consideration, the professional making portraiture in the home the main feature of his work.

148. **Easily Mastered.**—At-home portraiture is extremely fascinating and, although requiring a considerable amount of patience, as well as a practical knowledge of the principles of lighting and composition, it presents no serious difficulties in securing excellent results. In fact, so delightful is a session of home-portrait art work, with a suitable and sympathetic model, that one's enthusiasm almost always overcomes the numerous difficulties of posing.

149. **Modifications in Lighting.**—No matter how carefully the lighting may have been made, some modifications of heavy shadows are at times necessary; otherwise the printed image would be exaggerated in one way or another,

giving a greater amount of contrast than appears in the original.

150. **Effect of Color.**—Then, too, differences in color lead to difficulties. The white of the dress will be rendered in a tone too bright when compared with the face and hands. Although color-sensitive plates may be employed to some advantage in securing the proper rendering of the "values," the advantage is small unless a color screen is also employed. Then, the exposure is so greatly prolonged as to make the work almost an impossibility. On printing the portrait negative it will be found that this difference in color, especially where freckles show as black spots, small lines appear as wrinkles, the cheeks seem hollow and the nose crooked, makes it necessary to pay special attention to the retouching.

151. **Character Destroyed by Retouching.**—It is an easy matter to destroy character in the face, making it a mere expressionless mass. Even when you know just what you wish to produce, you might not possess the required skill of hand to carry out the ideas by retouching. If you trust the negatives to some one else, even a professional retoucher, he may not be able to bring out the character lines as you have seen them on the ground-glass. For this reason the greatest of care must be exercised in making the lighting and in finishing the negative.

152. **Definite Aim in Portraiture.**—There should be a definite aim in all photographic work, but especially in At-home portraiture, as it is necessary to plan and know just what effects you wish to produce before attempting to pose and light the subject. Your individual ideas will have everything to do with your final results.

153. **Setting Must be Harmonious.**—It is quite essential that special attention be paid to the surroundings, as well as to the subject. For instance, it is entirely wrong to pose a figure against a background of strongly figured wall-paper, which would detract from the subject rather than add to the value of the portrait. Frequently, portrait "studies" are so overloaded with curtains, pictures,

furniture and bric-a-brac that the entire omission of the figure would have been a very distinct artistic gain.

154. **Likeness of a Person.**—Referring to Webster, we find that a *portrait* is “*the likeness of a person, especially of the face.*” It would certainly be an excellent idea to have these words emblazoned upon each and every camera. You should include in the portrait everything that will add to the likeness of the subject—omit everything else. In order to secure this effect study the expression and the natural pose of the individual. It may be necessary to include the hands, and sometimes even the feet; anything that will help to interpret character, leaving out all those features which tend to detract from it.

155. **Study the Subject.**—Study the subject previous to making an attempt at posing before the camera; acquaint yourself with the subject’s individual peculiarities, and, in posing, aim to reproduce as many strong characteristics as possible. Do not begin to “fish” for ideas on the focusing screen, while the sitter is losing confidence in you, and patience for the ordeal.

156. **Obtaining Ideas for Posing.**—Many excellent ideas may be secured by looking over the various popular magazines, as they contain splendid studies made by the very best photographic artists. If you will study these, many ideas will be presented which will lead away from the stereotyped forms of posing. It is sometimes a good plan to make a few rough sketches of favorite poses, some pleasing lightings or other details which you can study and impress upon your mind. Arrange and re-arrange until the whole scheme appears quite clear to you. This preliminary study is quite essential, although many workers consider it is time wasted.

CHAPTER IX.

At-Home Portraiture.

Part II.

Controlling The Light.

157. Why is it impossible to photograph a subject, with proper portrait effects, out in the open in broad daylight? Why is it imperative that any particular form of lighting or a special method of arrangement of light is necessary? Why is it impractical to place a subject next to a window, make an exposure and secure good results? These questions all lead up to the one vital subject of *lighting and the control of the light.*

158. **Flat Effects Outdoors.**—If a subject were placed out-of-doors, in the shade, and an attempt made to photograph it, the resulting effect would be extremely flat, owing to the unlimited amount of light that would come from all directions. There would be no particular points of light on the subject that would stand out more clearly than others. Of course, light draperies and light portions of the subject will reproduce light, and dark parts will be dark in the photograph, but there would not be any perceptible amount of relief, or roundness, shown in the finished print.

159. **First Steps Toward Controlling Light.**—True, characteristic and pleasing effects may be produced out-of-doors, but it is necessary that some methods or means of controlling the immense expanse of light be employed. For instance, it is almost impossible to place the subject in strong sunlight and expect to get a pleasing effect. It is

necessary that the person being photographed be posed in the shade. As soon as this position is taken, action toward controlling the light begins. If the subject is placed on the shadow side of the house, the house itself acts as a curtain—shutting off the light from one side. Still, a flood of light will come from the top, so it is necessary to go a little farther and, perhaps, place the subject under a porch. Now two sides are screened from the flood of light, and if a background is placed at one end of the porch it would be possible to obtain a fairly pleasing portrait.

160. **Flesh-Effects Lacking.**—Still, there will be too much light uncontrolled, causing the face of the sitter to appear quite flat, with no possibility of flesh-effects in the finished print, all of the high-lights being hard and the shadows lifeless.

161. **Effect of All Side Light.**—If the subject is placed in a room, quite near a window, with opaque shades pulled down from the top until the light comes in only at the lower half, all shadows will be cast straight across the face; the side next to the light will be in very strong light, while the opposite side will be in heavy shadow. The effect produced will, therefore, be quite contrasty and not pleasing.

162. **Effect of All Top Light.**—If the other extreme is resorted to, the lower half of the window being curtained with some opaque material and the upper half left open, the light will fall on the subject almost directly from the top, heavy shadows being cast under the eyes, nose, lips and chin. The strongest light will, of course, be on the top of the head; the eyes will appear deeply sunken, and the whole result ghastly in appearance.

163. **Light Falling Properly.**—If the light falls on the subject at an angle midway between these two extremes, it illuminates both of the eyes, does away with the straight shadow across the face, follows the lines of the face, strikes the little prominences of the various features, accentuating them, and the whole effect is one which pleases and delineates the better characteristics of the individual.



MOTHER AND CHILD

STUDY No. 6—See Page 402

MARY G. HUNTSMAN



PUNISHMENT

STUDY No. 7—See Page 402

HELEN W. COOK

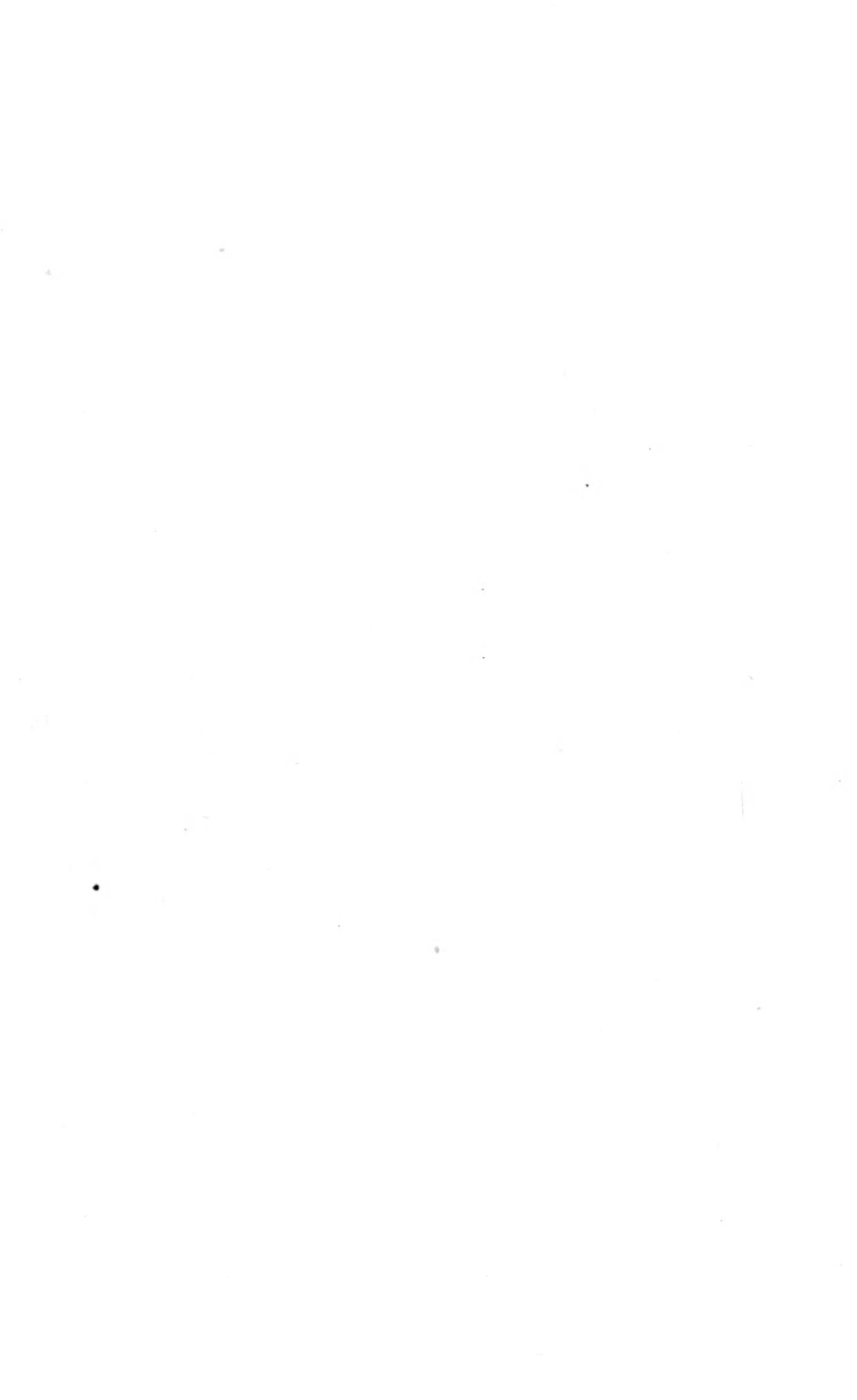

164. **Controlling Light—A Necessity.**—From the foregoing it will be understood to be absolutely necessary that some method, or means, be adopted for controlling the light and enabling the production of any desired effect, although it is not necessary to have expensive paraphernalia.

165. **Diffusing the Light.**—Even though the light may fall at the proper angle, there may still be deep shadows on the side of the face farthest from the light. The parts of the face receiving the strongest volume of light may be too white, so it is necessary that the light be further controlled. This is accomplished by placing a piece of thin cloth—such as cheese-cloth or muslin—over the window, softening the light; not only reducing the harshness of the high-lights, but diffusing the light throughout the room so that the shadows receive better illumination. This, then, reduces the amount of contrast and gives a softness which is unobtainable if the hard direct light is allowed to fall on the subject.

166. **Reproducing Character.**—It will now be understood that lighting is the art of reproducing character in the subject by correct application of light and shade. We may go on indefinitely and speak of the methods of controlling the light to produce various effects, and to bring out the strongest characteristics of the subject, but as each subject requires individual treatment this is hardly practical. There are, however, general principles and rules which are applicable to all classes of individuals, it having been found by the master portrait painters that one or two particular forms, or styles, of lightings are best suited to the general class of subjects. The photographer who, to a certain extent, has copied after the painters, can also see at a glance that some certain form of lighting is best suited to each subject.

167. **Plain or Broad Lighting.**—The lighting most universally favored is termed a Plain or Broad Lighting. This is a lighting in which most of the face is well illuminated, with the light coming a trifle from the front of the

subject and falling on the features at an angle of about 45°. The face of the subject should be gradually turned from the source of illumination until the tip of the shadow cast by the nose almost touches the shadow on the shadow cheek. The camera should be placed close to the window, to secure a view of the face that will show most all of it in light. When this effect is secured we have what is known as *Plain, or Broad, Portrait Lighting*. It is best adapted to the general class of subjects, as the light is thrown onto all parts of the face. If the subject has hollow cheeks, or wrinkles, which should not be exaggerated, but toned down, this form of lighting will be found to be the best to apply.

168. **Rembrandt Lighting.**—If the camera were placed to secure the same view of the other side of the face, the majority of the face would be in shadow, and what is photographically known as the Rembrandt Lighting would be secured. This is a strong character lighting, and it is necessary that careful consideration be given to the features of the subject before attempting to photograph to secure this effect. Faces somewhat thin, or with cheeks a trifle hollow, will not give pleasing results. Faces that are full and round photograph best under this particular form of light.

169. It will now be seen that some method of control is absolutely essential, if the character lines of the individual are to be retained and artistic effects produced.

CHAPTER X.

At-Home Portraiture.

Part III.

General Information.

170. **Studio Unnecessary.**—Of course it is understood that a studio is not required for At-home portraiture. The carefully arranged lightings of the studio do not, as a rule, produce portraits of friends as we are accustomed to see them, but the lightings possible to secure in an ordinary room do assist very materially in rendering a true likeness. Of course, there are some disadvantages in making At-home portraits: *First*, the light is at times so poor that a lengthy and tedious exposure is required, unless you possess a very rapid portrait or anastigmat lens. *Second*, the room is sometimes so restricted in size as to hamper one in getting the proper view of the subject. In such cases as this, it should be borne in mind that there is "out-doors," with its unlimited amount of open air and light, to fall back upon. In the summer-time, however, there should be plenty of light, even indoors, for At-home portraiture, with the lens working at f. 8.

171. **Advantages of a Studio.**—The large skylight and portrait lenses in the professional studio serve to shorten the exposure, and to that extent are of great assistance. By carefully following the instructions given in this lesson, however, no difficulty should be experienced in properly lighting the various subjects, by means of the illumination from an ordinary window, in such a manner as to make long exposures entirely unnecessary.

172. **Advantages of Home Surroundings.**—With proper accessories the studio photographer can obtain the results secured in any home, if time is taken and necessary patience exercised to obtain the home effect. This is very seldom done, though. Posing with the aid of painted back-

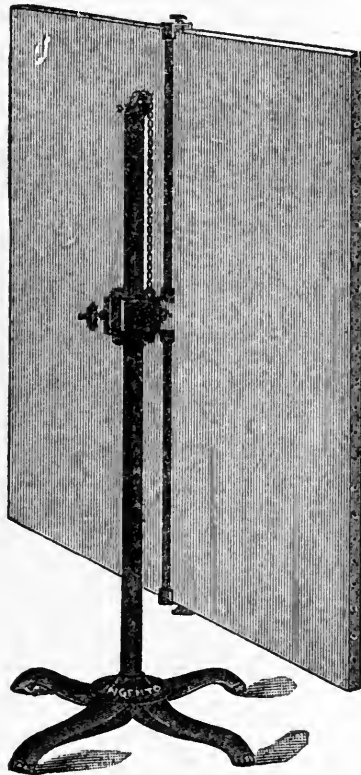

Illustration No. 9
Ingento Background Carrier
See Paragraph No. 174

grounds very seldom gives the pleasing results to be secured among home surroundings. Natural effects and perfect likenesses, therefore, are far more easily secured in the home.

173. **The Background.**—The question of the kind of

a background to use is very important. Portrait lightings made in the home, or by the regulation window, are sometimes a failure, because these accessories are unsuited to the surroundings. A most pleasing background is one painted a plain, neutral tint, slightly clouded. Such a ground is suitable for bust portraits or two-thirds figures, and supplies an excellent universal ground that is easily controlled in the lighting.

174. **Temporary Backgrounds.**—In case of emergency, suitable material can be found in any home, which may be successfully employed for backgrounds. Dark shawls, draperies, rugs, or even the focusing cloth, may be employed, and if properly handled good effects may be obtained with them. The plain painted, neutral tinted ground, slightly clouded, is one of the most serviceable pieces of accessory you can have, and with it many obstacles may be overcome. Such a ground should be stretched on a wooden frame, to keep it from wrinkling. The frame may be fitted with braces, or feet, which are castored, enabling you to not only move it about freely, but also serving as a brace to hold the background in position without other support. An excellent background carrier (the Ingento) is shown in Illustration No. 9. It can be obtained from any dealer in photo supplies, and is a decided convenience to the At-home portrait photographer for making bust portraits or two-thirds figures.

175. **Importance of Omitting the Unnecessary.**—When making pictures amid home surroundings, it is as important to study what not to take as what to include in the view. Keep a sharp look-out to exclude from the picture those things which do not improve it, and which might prove to be quite injurious to the general effects. Arrange the subject with surroundings suitable to the position given, studying the picture on the ground-glass with the idea of removing everything which may detract from the subject. Highly polished furniture—chairs, tables, etc.—unless promptly handled, will, by reflection, produce displeasing white spots. When you observe these spots elim-

inate them by altering the position of the furniture with reference to the light, or by throwing a drapery over the objectionable spot.

176. **Avoiding the Necessity of Retouching.**—Lack of ability to retouch negatives is supposed to be a great handicap to the amateur photographer. Of course, negatives can be sent out to be retouched, if it is thought to be advisable, but in most cases it is not at all necessary. A rough printing paper dispenses with much of the need of retouching. Even if it is only medium rough, the coarseness of the paper tends to hide blemishes.

177. **Use of Celluloid.**—A piece of sheet celluloid, either matte or clear smooth surface, and not too thick, placed between the negative and the printing paper will, to a great extent, overcome the necessity of retouching, and in some cases do away with it entirely, if the negative is of good quality. If it is under-exposed and then developed to such a point as to exaggerate all the contrasts; or if the face of the subject is focused microscopically sharp, and a very short exposure given to minimize all risk of movement, there is no remedy but to resort to the art of the retoucher.

178. **Obtaining Softness.**—We do not advocate fuzziness in the extreme, but a little *softness* is, in itself, an improvement to the photographic portrait. It also helps to do away with the need of retouching. Softness is obtained by using a wide open lens—at its largest working aperture—and by giving sufficient exposure, even should there be a slight movement on the part of the subject, it will not be perceptible, but will tend to soften blemishes and harsh lines.

CHAPTER XI.

At-Home Portraiture.

Part IV.

Backgrounds.

179. Many photographers lose sight of the part played by the background in successful portraiture. They seem to be content to use what happens to be behind the sitter at the time, without further effort to secure a background that will help the composition. The backgrounds we will describe are not drawings with fictitious details of scenery supposed to be behind the sitter. Our idea is rather to offer suggestions that will aid in suppressing unsuitable wall paper, which so frequently spoils good pictures. The following instruction should greatly assist you in making a cheap, serviceable background, and also thoroughly train you as to the best methods of using it.

180. Of all At-home portraits that have been brought to our attention, fully three-fourths were practically ruined on account of the inconsistent use of the background. You can possibly recall cases where the amateur photographer, anxious to take a portrait, has placed the subject against the wall, indoors or out, making the exposure without any further background preparation. It may be thoughtlessness; it may be a desire to avoid trouble; or, the fact that the character of the wall-paper or brick wall in the final photograph is not so marked on the ground-glass. Whatever the reason, the thing is done, and the following instruction is intended to suggest something better.

181. **Let the Background be Simple.**—It is almost as great a mistake to have an elaborate arrangement of things intentionally placed behind the sitter for effect, as it is to have the unsightly figures of the wall-paper. In a previous chapter we said that “a portrait is the likeness of a person, especially the face.” Now, introduce the wrong accessories and you weaken and diminish the part played by the sitter. This is the mistake so many of the old style professional photographers made. Their studios were crowded with tables, cushions, “rock-work,” and other devices, which were not only make-believe and offensive in themselves, but, even had they not been so, they interfered greatly with the effectiveness of the portrait as a likeness.

182. **Selection of Accessories.**—It requires the utmost skill and keen artistic sensibility to use accessories successfully, and the At-home portrait photographer will find that it is much better to abandon accessories and background details altogether. Make up your mind that the portrait shall just show the subject against a plain tinted ground—light or dark—that, and nothing more. It is not only an easy way out of the difficulty, but also an effective one. By examining salon work, and photographs that have captured prizes in leading competitions, or secured medals at the various state and national conventions, you will observe that in the majority of the pictures the backgrounds are extremely plain and simple.

183. **Value of Plain Background.**—Where the plain background is used in making the negative, it allows for special dodging and altering in the printing. Light spots may be worked in the background, on the glass side of the negative, in order to break the monotony of plainness. This provides a means for the display of one's own individuality, as by such means one may place these spots wherever he likes, and upon the accuracy of the placing depends their value as to the improvement of the picture.

184. **Plain Background.**—Plain backgrounds may be made from an ordinary dark-colored window shade—usually the green or deep slate color is the most suitable. By

attaching the window shade to a spring curtain roller and then fastening the roller to the top of an ordinary screen, you have a convenient and suitable background. When the ground is not in use it may be rolled up, where it is out of the dust, and in its compact form can be stored away.

185. **Painted Backgrounds.**—Suitably painted grounds can be obtained from most photographic supply houses.

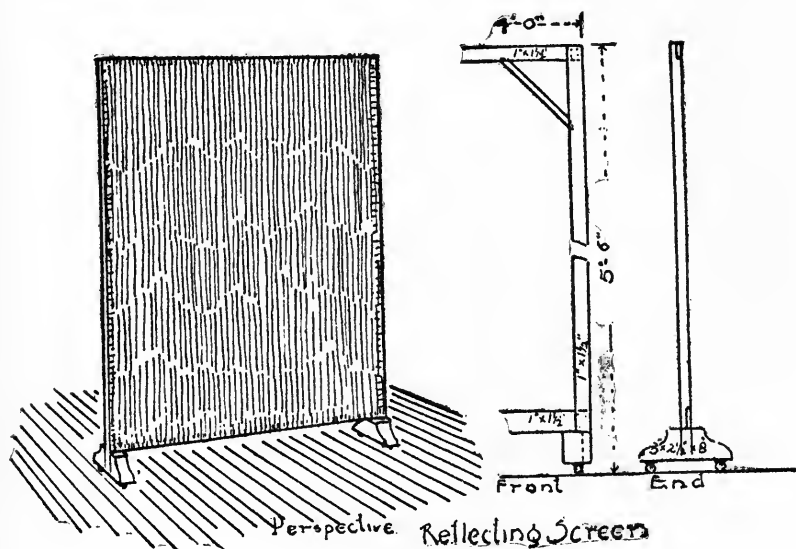

Illustration No. 10
Construction of Background Frame
See Paragraph No. 185

When purchasing a painted ground it is advisable to purchase a gradually blended ground. By this we mean a ground which is blended from side to side in tints from dark brown to deep gray. The size of the ground best suited for all purposes would be about 5 x 6 feet. Provide a frame 5 x 6 feet, outside measurements, using strips of pine or any soft wood, 2 inches wide by $\frac{7}{8}$ inch thick, with both sides and edges planed. (See Illustration No. 10). Stretch the ground on this frame, placing two large screw eyes near the edge on the top and the bottom. Then pro-

vide an extra frame 6 inches wider—with standards at the base to hold it upright. Drive two large nails or hooks in the upper portion, to receive the screw eyes in the background frame. It is possible by this means to work from either side of the light. You can always have the dark end of the background next to the light by simply inverting it.

186. **Stretching the Background.**—A little care must be exercised when stretching the background, in order to avoid wrinkles. The following suggestions may be of service to those who have had no experience along this line:

187. First, place the background face down on the floor. Be careful that there is nothing on the floor to mar it. Next lay the frame on the background. Then, beginning at the top of the ground, draw it over the edge of the frame a trifle, and beginning in the center drive in a couple of tacks. Do the same at the bottom and sides, being careful to always drive the first tacks at the exact center. Complete the tacking by always drawing carefully from the center. Tack first to the right and then to the left. Do not try to stretch the canvas—just draw it equally from the center.

CHAPTER XII.

At-Home Portraiture.

Part V.

Making General Preparations.

188. **Selecting a Window.**—Before attempting to make At-home portraits, it is necessary to have a few pieces of apparatus to assist in securing proper lighting effects. The first consideration lies in selecting a window from which to derive the source of light. A window facing north is best, as much more uniform lighting may be obtained from a window with a northern exposure. A north window is always free from strong sunlight, the illumination being soft and diffused at all times of the day, and, therefore, easily controlled.

189. **Unobstructed Light.**—The light should not be obstructed by trees, porches, or other objects, and the higher and larger the window, the better will be the general results. The great advantage of having a high window lies in the fact that exposures can be made further from the source of light, thus obtaining more diffusion.

190. **Avoid Reflections.**—The sun shining on the window through which the source of light is admitted will cause a reflection upon the subject. Unless this reflection is overcome in some way, it will be impossible to control and concentrate the light, which will be necessary in order to produce a correct Plain Lighting. For this reason the use of a window facing the north is advised, as the sun will never shine on it, which insures complete absence of

reflection. If light is secured through a north window there will be no need for diffusing the light, other than with the diffusing screen.

191. **How Windows Facing South, East or West Can Be Made Use Of.**—If a room containing a window facing the north cannot be secured, any unobstructed window can be made to do by diffusing the strong sunlight with cheese-cloth, or thin bleached muslin, stretched over the entire window. The cheese-cloth is employed to subdue the

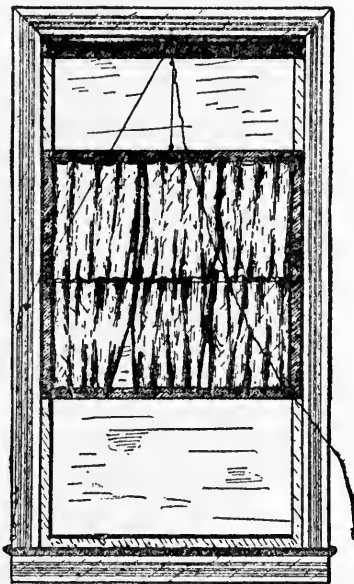

Illustration No. 11
Light Controlling Screen
See Paragraph No. 193

strong sunlight, reducing it to about the same conditions as light coming through a north window. In order to control the light the regular diffusing screen must be used, in addition to the cheese-cloth. On account of the light constantly changing, it will be found to be more difficult to

produce good results with a window upon which the sun shines than one with northern exposure. If a room with a north window cannot be procured, it will be better to select a west, or even an east light in preference to one facing south. If a west light can be had, the necessity for screening the windows can be obviated by working in the forenoon, as the sun will not interfere until later in the day. If an east light is employed use it after the sun has left the east side, or during the afternoon. In this way artificial diffusing of the harsh sunlight can be avoided, and results as good as may be secured with a north light can be obtained. Of course, when it is necessary to use the light at all times of day, and other than a north light must serve, use the screen while the sun is shining, and remove it when there is no direct sunlight on the window.

192. **Preparing the Window.**—In preparing the window it is necessary to provide a diffusing screen. This diffusing screen is really a light-controlling screen and should be attached to the window in such a manner that it can be readily raised or lowered.

193. **Light Controlling Screen.**—See Illustration No. 11. This screen should be made in the following manner: Make a light frame, using strips of wood about $1\frac{1}{2}$ inches wide by $\frac{1}{2}$ inch in thickness. For the ordinary house window, this frame should be about 30 inches high, and the exact width of the inside of the window casing, allowing for slight play. Stretch four wires across the frame—two across the center, two inches apart, one across the top, and one at the bottom of the frame. Attach the wire to screw-eyes, stretching from one screw-eye to another. Next procure two yards of white cheese-cloth about 30 inches wide.

194. **Dyeing Cheese-Cloth in Coffee.**—Dye the cheese-cloth a light coffee color. This can be very easily accomplished by boiling the cheese-cloth about 10 minutes in strong coffee, to which has been added a heaping teaspoonful of salt. Rinse the cheese-cloth in clear water, and allow to dry. With the light tan stained cheese-cloth

the softest grade of diffusion can be obtained, securing the mellow high-lights which are so important in artistic home portraiture.

195. **Diffusing Curtains on Controlling Screen.**—Cut the cloth in three parts, so as to make two sets of curtains, three sections to each set. Make allowance for at least a one inch hem at top and bottom. String the curtains on the wires, having them hang in folds, and quite full. For a thirty-inch window you will require a width and a half for each section. The full width should be split to form the third section. After stringing the curtains fasten the wire to permit them to slide smoothly.

196. **Hanging Screen in Window.**—On the upper edge, in the center of this frame, insert another screw-eye. At the top of the window and close to the sash attach a small self-locking pulley. Fasten one end of a long cord to this screw-eye, and run it through the self-locking pulley. By pulling or releasing the cord the diffusing screen can be raised or lowered at will. A screw-eye hook may be substituted in place of the self-locking pulley. In that case, however, attached to the side of the window casing should be a button, to which the cord can be attached when the diffusing screen is properly adjusted. (See illustration of window screened).

197. **Two Light Controlling Factors.**—All lace curtains should be removed or drawn back from the window, allowing only the opaque shade or spring roller to remain. The spring roller shade can be raised or lowered, as desired, to cut off top light that may not be required. With the opaque shade and diffusing screen in operation, absolute control of every ray of light entering the room through this window will be at the disposal of the photographer.

198. **Substitute for Painted Background.**—If a background is not among your possessions, substitute an ordinary plain dark colored curtain or rug, which may be suspended from the picture moulding either in folds, or plain. In an emergency anything of this kind will prove satisfactory as a background, and sometimes the resulting effects

will exceed in quality those that could be produced with a graded ground.

199. **Reflecting Screen.**—For the reflecting screen prepare another stretcher 3 feet wide by 5 feet high (See Illustration No. 10). Use the same size material employed in making frame for the background. Cover this with white muslin, stretching it in the same manner as with the background (See Paragraph No. 187). This is to be used as the reflecting screen for portrait work. To conveniently move the background or reflecting screen, the frames should be fitted with castors, which are to be fastened to cross pieces at the bottom of the base of the frames. While both background and reflecting screen may be used without castors, much is added to the convenience in handling by having them. When employed without castors they can be held in position by using chairs for back support. When not in use, place face to face, resting against the wall, where they will occupy little space.

200. **The Subject.**—Frequently, successful results are only obtained after working with the subject for a considerable period of time. For this reason, with first efforts in portrait work be prepared to give careful thought to the work, and do not be discouraged if failures are encountered. Determine in advance about the pose and style of lighting it is proposed to apply to the subject. Strive to carry out this idea; stick to it until the results desired have been obtained. Frequently it will be found that the best positions are those assumed more or less unconsciously by subjects themselves.

201. You must have practice, and for your experimental work select a friend, who is interested in your work, to pose for you, because sitting before a camera operated by an inexperienced student becomes quite tiresome, unless the person is somewhat interested in the work themselves.

202. Women usually make better subjects than men, as they enter more into the spirit of the work, are more patient, less restless, more graceful, and for these reasons lend themselves naturally to posing in different positions.

With women for your subjects there is also a better opportunity for lighting; *i. e.*, you may obtain more variety of lightings of them than of men, and the effect of the light is more apparent.

203. **Number of Plates to Expose.**—It is not necessary that you expose a large number of plates, as no plate should be wasted on a pose that is not good. In fact, for practice work it is necessary to make but few exposures. Simply practice altering the light to produce different effects. Observe the effect of the light with the subject close to the window and further away; then, with the diffusing screen low and high, turning the figure first one way and then another, towards the light and away from it, leaning forward and backward. Observe the effect of light and the general balance and pose of the subject under these conditions. This will train you to observe quickly and judge the proper effects when they appear. Should you, during your experiments, obtain a lighting or a position of the subject which you consider just right, make a negative. A few negatives made during each day's experiments are sufficient. This however, applies only to the experimental or training stage, because when seriously at work it will often be found advisable to use an extra plate or two, for sometimes such chance shots will turn out great successes.

CHAPTER XIII.

At-Home Portraiture.

Part VI.

Plain Portrait Lighting.

204. **The Subject.**—We will now take it for granted that all the necessary arrangements have been made, and that you are in possession of a well appointed home studio. For the beginner an adult person will make the best subject, for the reason that children are likely to tire easily.

205. **Placing the Subject.**—Always place the subject as far from the window as possible. This distance is governed entirely by the light, which latter should fall at the proper angle and give sufficient illumination to enable one to secure good modeling and reproduce the character of the individual. In the ordinary home the distance from the subject to the window will usually correspond to the breadth of the window sash, and this distance may be taken as a guide until, after a few experiments, your judgment as to the proper distance has become more accurate. If placed too near the window, the light, being too direct and strong, will cause high-lights of excessive strength, and deep shadows. On the other hand, if the subject be located too far into the room—away from the source of illumination—the angle of the light will not be correct, as the shadows cast by the nose and other prominences will fall straight across the face, and the contrasts, even in this position, will not be materially reduced.

206. **Atmosphere—Roundness.**—To secure perfect at-

mosphere—the greatest amount of roundness—in portraiture the strongest light should fall on the features nearest the camera, and gradually blend back into the shadows. To obtain this result the subject should be placed in a position which will allow of the light falling on the face from the front as well as from the side and top. The proper location depends much upon the height of the window, but in all cases the subject should be far enough from the window to allow the rays of light to fall on the face at an angle of about 45° . The subject should also be a little to the rear of the window casing next to the background. In such a position the ear on the light side of the face will not receive the light in the same degree of strength as will the front of the face. The strongest light will fall on the edge of the nose; the next in strength on the forehead, then on the cheek, lips and chin of the light side of the face, while a delicate half-tone or “catch” light will be visible on the shadow cheek.

207. **Controlling the Light.**—As the window in the home does not admit a large volume of light, those rays that are allowed to enter the room will produce a somewhat contrasty effect. For this reason it is necessary to employ such means as will assist one in securing softness and modeling. The diffusing screen on the window and the reflecting screen, which is placed on the shadow side of the subject are the two important accessories for the controlling of the light. The **diffusing screen** filters the volume of light as it enters through the window, and in so doing diffuses and spreads it over a large area, subduing the harsh effect on the high-lights and softening the shadows so the contrast between these two extremes is very much lessened. If the contrast cannot be reduced sufficiently in this way, the **reflecting screen** should be placed at an angle with the window, to soften the line which may still exist between the high-lights and shadows. Extreme care must be exercised when using the reflector, that it is not placed parallel with the window, for the reason that the light will either be thrown too strongly on the rear of the shadow side of the

face or the reflected light will not touch the subject at all—simply being cast back to the window. It cannot be too emphatically stated, that the strongest light on the face in a Plain Portrait Lighting should be on that part nearest to the camera. For this reason the reflector must be judiciously handled. It should act simply as an agent to give harmonious blending between the high-lights and the shadows.

208. Referring to Illustration No. 12, observe the posi-

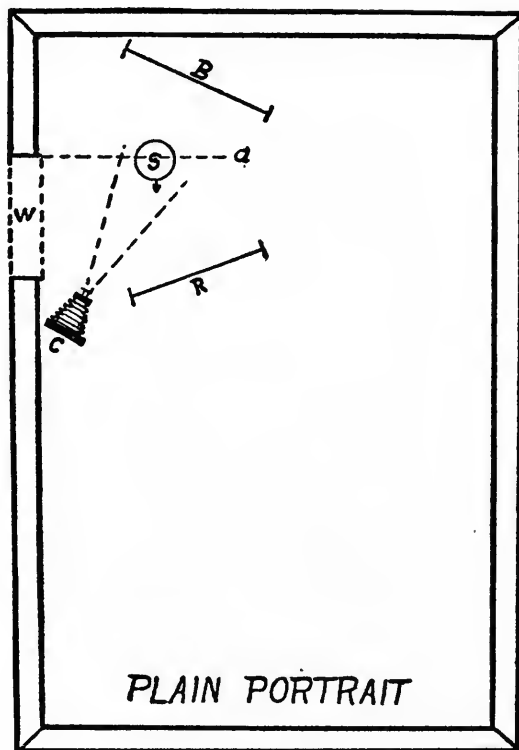

Illustration No. 12
See Paragraph No. 208

tion of the subject, the camera, the reflecting screen and the background. The reflector should be at least 3 feet to the side and the background 3 feet to the rear of the subject.

The reflector should catch a little of the direct light and throw it onto the face, so as to obtain proper blending from the highest points of light to the deepest shadows. The angle at which the background is turned will depend entirely upon its nature and the effect that is desired. Usually, however, the background should be at a right angle with the axis of the lens.

209. **Posing the Subject.**—The beginner should make no attempt at set posing. The more simple the pose the better. *First*, seat the subject figure and face toward the window; *second*, slightly turn the face from the window; then, watch the effect of the light as it falls upon it. The face and figure should never be posed at the same angle. If the subject is a lady gowned in light drapery, the lines of the face permitting, in order to save the drapery and obtain all the detail possible turn the figure into the shadow and the face toward the light. This rule will not always hold good, however, as frequently the angle of the neck and contour of the face are such, that to obtain the most pleasing results of the face—most essential in a portrait—it will be necessary to reverse this order. If the window supplying the illumination is so located as to permit of the subject being placed at either side of the light, arrange the subject on the side that will give the best portrait and drapery effects.

210. In making bust pictures, carefully square the shoulders never allowing one to be higher than the other. Only in extreme cases, and particularly in reclining positions, where more of the figure is shown, is it permissible to deviate from this rule.

211. **Attention to Details.**—It is very essential that the arms and hands receive special attention, even in the making of a bust portrait. The height of the chin, which, to a certain extent, governs the length of the neck and nose, the arranging of the hair, and the direction in which the eyes are turned all require special attention. These points are covered in detail in the following chapter.

212. **Lighting the Subject.**—The angle of light upon

the face of the subject is obtained, as previously stated, by placing the subject nearer to, or at greater distance from, the source of light. The height of the window regulates the distance from the light at which the subject should be placed. If the window is extremely high, the light may be lowered by drawing down the top opaque curtain. With a fair sized window, which will permit of working at a little distance from the light, the high-lights should be obtained and accentuated by the direct light coming from the window over the top of the diffusing screen. The object of the diffusing screen is to soften the strong light as it falls upon the subject. As the flood of light grows stronger near the lower part of the window the diffusing screen must be used to diffuse the light from this portion of the window.

213. More than one window—unless close together—should seldom be used; only in extreme cases is it advisable to resort to a divided source of illumination, and, even then, if one is experienced he will be able to produce equally as good results with the one window. As light is required to make a picture, one should use all of it obtainable, bearing in mind, however, that it must be sufficiently controlled to produce the proper effect. For this reason use *all* of the light admitted through the one window, diffusing only where necessary.

214. If the window is small or low, necessitating the placing of the subject closer to the source of light to obtain proper angle of illumination, you will find quite likely that the high-lights will be rather strong and hard. If they appear too hard soften them with the diffusing screen, by raising or lowering until the proper diffusion is obtained. It is advisable, however, *first* to obtain the angle of light by the open window before diffusing; *second*, after placing the subject, to observe the shadow cast by the nose on the shadow side of the face. When this shadow falls slightly below the nose, inclining toward the corner of the mouth, the correct angle, which is about 45° , will have been obtained. (See Illustration No. 13.) *Third*, see that the high-lights are soft. If too hard, soften them by closing the cur-

tain on the diffusing screen. If still too strong, move the subject further from the window, at the same time watching closely the shadow cast by the nose.

215. It is seldom that sufficient softness cannot be obtained with the diffusing curtains, if they have been made of the proper material. If the light is still too strong, rather than move the subject too far away from the light, it would be advisable to place another thickness of cheese-cloth over the diffusing screen. If, with the curtains on the diffusing screen drawn together, the light is too much diffused, by separating them a trifle the high-lights may be strengthened sufficiently to give them the desired snap.

216. The high-lights should be sufficiently strong to leave half-tones visible. You will notice by reference to Illustration No. 14, that more light is admitted from the top of the window than at the bottom. The strongest light always comes from the center of the window, and below. Because of this condition the light from the lower part of the window is softened with the diffusing screen, which, being attached to a cord, permits of its being raised or lowered to soften the lights on the subject where needed.

217. **Placing the Background.**—Properly illuminating the background is almost as essential as lighting the subject. Place the background at least 3 feet from the subject, and turn the end of the ground furthest from the window slightly toward the source of light. If the ground is graded—or clouded—have the lighter section directly behind the shadow side of the face. This procedure will bring the dark portion of the background back of the illuminated side of the face, which is nearest the window. If the ground is placed too near the subject there will be excessive sharpness, causing the portrait to lack atmosphere. By turning the ground from the source of light a darker background is obtained; by turning it toward the window a far lighter effect is secured.

218. **Position of the Camera.**—By reference to the accompanying illustration and floor plan the position of the camera in making this lighting may be noted. In order to



Upper Illustration No. 13—See Paragraph No. 214
Lower Illustration No. 14—See Paragraph No. 216

AT-HOME PORTRAITURE—PLAIN PORTRAIT LIGHTING



LADY AND CHILD IN OPEN DOOR

STUDY No. 8—See Page 402

J. H. FIELD

secure the best effect in photographing this subject the figure was turned away from the window, and the face turned toward the light until the tip of the shadow cast by the nose just touched the shadow of the cheek. For Plain Portrait Lightings you will need to work with the camera closer to the wall than the subject is to the window; in fact, the best position of the face is secured when the head is turned so the shadow ear is just out of range of the lens. The illustration shows a two-thirds view of the face and a side view of the body. The side view of the figure turned from the light gives softness to the drapery and the face turned towards the light supplies strength and roundness to the head.

219. **Proper Height of the Camera.**—As a rule, the camera should be placed on a level with the mouth of the subject, except in the case of standing figures. Much depends, however, upon the subject. For instance, if the subject is a fleshy, short-necked person, lower the camera. It is well, in such cases, to have the subject lean forward a trifle, with the head slightly erect, thus showing as much neck as possible. Usually a view of the shadow side of the face will avoid the double chin effect, yet the handling of subjects in order to secure special effects should not be attempted at this stage. There are no fixed rules governing these points, so the photographer must be largely guided by the character of the subject and the surroundings.

220. **Exposure.**—The greatest difficulty experienced in home portraiture is to comprehend the vast difference between the density of light *in* and *out* of doors. The variation of exposure is so great that where 1-25th of a second would be sufficient exposure for a view out of doors many times this amount would be required in a well lighted room. The misjudgment of time and under-exposure no doubt account for the production of many negatives that lack in gradation and, consequently, show extreme contrasts.

221. Take into consideration that in the open air there is an immense volume of light evenly distributed, while indoors the volume of light is greatly decreased, and the illum-

ination is also unequal, for the light in the room coming from a small opening or window is concentrated and, consequently, unevenly distributed throughout the room. It is, therefore, necessary, in order to be able to give correct exposure, that you become familiar with the strength of light in the room used. By practice and close observation alone can this be accomplished. Until familiar with the required time for various effects, keep a memorandum of the time of day, prevailing conditions and length of exposure given every subject, being guided by the average results.

222. One point must always be borne in mind—that is, you must time for the shadows. By this is meant you must expose long enough to supply detail in the shadows, no matter how much the high-lights are over-exposed. The general tendency is to under-expose. Never light a subject with strong high-lights and dense shadows, but soften the high-lights by diffusing them with the diffusing screen on the window. When diffusing the high-lights in this manner the illumination of the shadows is very materially aided, for by diffusing the concentrated light coming from the window it is spread over a larger area, consequently illuminating a greater portion of the room, resulting in more illumination for the shadows. If carried too far, however, the diffusion will result in flatness; therefore, aim to diffuse only enough to give softness to the high-lights, as the shadows also can be illuminated by means of the reflecting screen. Because of this, bear in mind that when diffusing the high-lights the shadows are illuminated as well; also, remember that with strong high-lights there will be dense shadows, and that the denseness of the shadows regulates the length of exposure. Soft high-lights and well illuminated shadows, whether obtained by diffusion or direct light, will enable you to work with a more rapid exposure.

223. To determine, approximately, the necessary exposure for At-home portraits, it is advisable, after selecting the room to be used as a studio, to first make an exposure of the interior of the room, taking into the view the window prepared for use. In making this exposure of the interior,

time for the shadows at the far end of the view opposite the window. If it requires 40 seconds to produce a fully timed plate of an interior about 14 feet wide, it will require approximately 15 seconds (or a little more than one-third this exposure) to fully time a portrait with the subject placed at half that distance, or seven feet from the light. With the subject about one-quarter the width of the room from the window, or $3\frac{1}{2}$ feet, the time required will be about one-third of the exposure necessary when the subject was 7 feet from the light—or 5 seconds. If a lens that will give a fully timed interior view in less time than 40 seconds is used, less exposure for the portrait will be required. If a fully timed negative of the interior has been produced, you will have a guide for future experiments under like conditions, taking into consideration, however, that the nearer the subject is to the camera—producing a larger image—the longer will be the exposure, and *vice versa*.

224. When a portrait or rapid anastigmat lens is used an exposure of from $\frac{1}{2}$ second to 2 seconds is usually sufficient. With a rectilinear lens, or the lens usually fitted to hand cameras, longer exposure will be required; the exact amount depending upon the speed of the lens, which can only be ascertained by trial.

225. **Developing.**—After securing a negative which you think is exposed approximately correct, it is advisable to start the development of the plate in normal developer, watching it closely (see Universal Developing, Volume II). As soon as the image appears, examine it by holding the plate before the ruby lamp, looking through the plate. Observe whether the plate is developing evenly and if it was properly timed. Should the plate show signs of under-exposure immediately treat it as an under-exposed plate. (See Developing Under-Timed Plates, Volume II.) If over-exposed, change at once to a developer prepared for over-exposures. (See Developing Over-Exposures, Volume II.)

226. A good plan is to have three trays ready for use when developing; one containing developer prepared for over-exposures, another holding developer for under-ex-

posures, and the third for the normal developer. By preparing these three developers before beginning work, you can immediately manipulate the development and overcome all difficulties that may arise from improper exposure.

227. **Practice Work.**—In preparing this lesson it is advisable to make two exposures of this style of lighting. Give the first plate what you would consider a normal exposure, while for the second give a longer exposure. Do not attempt to hurry when lighting and posing the subject. Study every move necessary to the securing of a proper light on the subject. When this is accomplished observe the image on the ground-glass and make a careful estimate as to what you think will be the required length of exposure. Everything being in readiness, insert the plate-holder into the back of the camera, draw the slide; then, having the subject in the desired position, with the eyes at the proper angle, make the exposure. A memorandum should be made of each step of the procedure, that your future work may be based upon the results previously obtained.

228. If this instruction has been thoroughly studied and carried out there will be little need for experimenting, and you should produce satisfactory results from the beginning.

229. Develop the normally exposed plate first, according to the instruction. After the plate has been fixed and rinsed, take it to the white light and examine it. If there is error in exposure or development, on developing the second plate strive to overcome the difficulty. If the first plate was properly timed you will know that the second plate, which received a longer exposure, is over-timed. Provide against flatness by developing the plate for over-exposure. If, on the other hand, the first plate should show signs of slight under-exposure, the second plate would be exposed about right and the normal developer should be employed. When the plates are dry, proof prints should be made from both negatives, on the back of which should be noted all data pertaining to their production. File these proofs in your regular proof file.

230. Before attempting to make other lighting effects, continue with Plain Lighting until satisfied that you are able to secure the very best results. Compare the first proof prints with the studies in Plain Lighting given in this volume; also with the illustrations accompanying this instruction. Study each and every feature of the face, both in the original example given herewith and in your own print.

231. Proof prints, with important data noted on the back of each, should always be made from all experimental negatives, and then filed away in regular order for future reference and comparison.

CHAPTER XIV.

At-Home Portraiture.

Part VII.

Posing Details.

232. The first essential in all portrait work is to secure proper effects of lighting; therefore the student should become thoroughly familiar with the instruction given in the preceding chapter before paying any particular attention to detail work when posing the sitter. Allow the subject to appear as natural as possible, and direct your efforts to holding their attention by talking to them. When you are able to correctly light the subject and secure properly exposed and developed negatives, you may then give special attention to posing the arms and hands, as well as to arranging the drapery, turning the head at different angles so as to produce the best effects, etc.

233. **Arms and Hands.**—With the lighting, exposing and developing accomplished, your attention should next be directed to the arrangement of the arms and hands. Whether the subject be a man or a woman, special attention should always be paid to the placing of the arms and hands, as their position governs the general balance in the portrait and controls the lines of the drapery. Even though a bust portrait only is being made, it is essential that the arms and hands rest easily so the shoulders will be squared and the sleeves and drapery arranged to hang gracefully. This is best accomplished by resting the hands on the lower limbs, midway between the knees and hips. If they are placed on

the lap or on the knees the subject will appear round shouldered. If they are allowed to hang at the sides the shoulders will be thrown back too far, thus appearing drooped.

234. **Wrinkles in Drapery—Men.**—If the subject is a man and the coat fits badly, having objectionable folds over the shoulders, place a wad of paper or a handkerchief under the coat directly beneath the wrinkles, and this fault will be eliminated. Be sure to pull the coat down in the back, so the white collar will show, also adjust the vest. If a scarf-pin is worn, or the watch charm shows, arrange them to prevent the catching of strong light, which will cause a conspicuous appearance in the picture.

235. **Women.**—When posing women your attention should be directed to the arrangement and the lines of the drapery, especially the sleeves, waist, collar, etc. Objectionable wrinkles should be unobtrusively smoothed.

236. **Height of the Chin.**—The proper height of the chin is vitally important to good portraiture. For the ordinary subject the chin should rest a trifle above the level, providing the camera is placed at the proper height. If the nose has an upward turn care must be taken that the chin is not raised too high—rather lower it slightly. This will give length and tend to straighten the curve. If the nose is of a drooping variety, raise the chin a trifle above the center, supplying length. Raising or lowering the chin must be done in a natural manner; see that the subject does not extend the chin forward or draw it in. The head should be naturally raised or lowered, or tipped to one side a trifle.

237. **Long, Prominent Noses.**—As a rule, this type of nose predominates with tall, slender people, and care must be exercised not to have the camera at an elevation above the nose. If the lens is above the level of the nose the full length of the bridge of the nose is reproduced, foreshortening the under side and exaggerating the nose in proportion to the balance of the face. If the camera is lowered sufficiently to foreshorten the bridge of the nose, showing more of the lobes, the nose will be made to appear less prominent and a more pleasing picture will be the result.

238. **Short, Stubby Noses.**—Short, stubby noses should be treated in the reverse manner; raise the camera to look down on the bridge of the nose, which will give the effect of lengthening this feature.

239. There are no fixed rules governing this point, other than above mentioned, but these suggestions should be found very helpful. Be guided principally by your subject and the surroundings.

240. **Short Neck.**—If your subject is a stout person, possessing a short neck, adjust the camera to a lower position, to show as much of the neck as possible. It is well, in such cases, to have the subject lean forward with shoulders thrown back slightly, thus extending the chest. More of the neck is shown when the head is held erect, and the appearance of stoutness is very materially reduced.

241. **Long Neck.**—For securing the most pleasing likeness of a slender person whose neck is long, the treatment is just the reverse of that applied to those having short necks. The camera should be raised a trifle higher than the level of the mouth, the height being regulated, to a certain extent, by the length of the subject's nose. The figure of the subject should be turned from the light, thus elevating the shoulders and giving the neck a shorter appearance.

242. **The Mouth.**—As the control of facial expression is governed principally by the mouth, one must pay strict attention to this feature of every subject. If it is closed too tightly, never request the subject to open the mouth. On the other hand, if it is open do not ask them to close it. In either case they are apt to go to the extreme. Converse with them, making it a point to ask a question on some subject certain to bring a pleasing answer; or even a pleasant remark requiring no reply will generally cause the mouth to shape itself naturally, and at that instant make the exposure.

243. When conversing with the subject does not bring about the desired expression, suggest the passing of the tongue over the lips, to wet them. This will produce a slight gloss on the lips, which helps to give a more natural

shape to the mouth. In cases of chapped lips, the wetting of the lips with the tongue overcomes the appearance of the soreness and the chapping will not be visibly prominent.

244. **The Eyes.**—Without regard to the position assumed by the subject, the eyes must lead the face under all circumstances. If the face is turned to the right the eyes should lead a little more to the right. If the face is directed to the left, then the eyes must lead to the left. Not only should the eyes lead the face, but they should also be inclined slightly upward—just a trifle above the level. This gives better expression, and more roundness is produced than if they were drooped, or even on a level. A drowsy, sleepy appearance will invariably be the result if the eyes are turned downward. An excellent rule to follow is *never to permit the white of the eye to show below the iris*. While the mouth controls the principal facial expression, the eye is a close second in importance. By properly directing the gaze of the eyes, not only is it possible to maintain a pleasing expression, but a too serious one may be modified to some extent.

245. **Note.**—It must be understood that these suggestions and rules pertain only to Plain Portrait Lighting, and do not apply to extremely odd posings and lightings of Genre type. In producing work of the latter character be guided entirely by the effects desired.

246. **Catch-Lights in the Eye.**—The surface of the eye, being a reflecting medium, acts like a mirror and reflects the light coming from the window. The location of this reflected spot is governed entirely by the angle of light as it falls upon the subject, and the turning of the face toward, or from, the light. This spot is termed a "catch-light," and its size depends upon the distance of the face from the light, also the size of the source of light. If the lighting has been correctly made, the catch-lights will appear in the upper corner of the light side of the iris of each eye. Upon close examination this catch-light will be found to be an exact reproduction of the window or other source of light.

The catch-light must not extend into the white of the eye, nor should it touch the pupil.

247. **Eye Rest.**—The ideal eye rest is the face of the photographer. One who is clever can instantly change the expression of a subject if the eyes rest upon him. By raising or stooping the eye can also be guided for height. It is possible to cause the eye to lead the face at any desired angle, by simply moving about, more or less, in one direction or another. Another advantage of the human eye rest is that, at the proper time, a word from the photographer will bring an expression that otherwise might be impossible to obtain. Of course, practice and experience are required before one can properly take the part of a human eye rest.

248. Then, too, there are people who cannot look at any one during an exposure. In such cases the photographer may hold one hand in the direction it is desired to have the subject look, requesting that he rest his eyes upon it. Or, a photograph attached to a cord and a rod having a substantial base, will answer. Attach the picture in such a manner that it will slide up or down freely. It will be necessary to place this rod at just the right distance from the subject, as the focal length of the eyes of all subjects is not the same. Observation will demonstrate that by placing the eye rest at a stated distance the pupils of the eyes of various subjects will grow larger or smaller, and often the eyes will assume a staring appearance.

249. Watch closely, placing the eye rest at a distance where the subject will experience no difficulty in viewing the picture. Some subjects are inclined to wink a great deal during exposure. Ordinarily this will do no harm, unless the winking is excessively frequent, when it is liable to cause a slight blur over the eye which can only be remedied by etching or retouching. Natural winking of the eye always results in good expression, providing the subject does not turn the eyes from the direction of the eye rest.

250. Never direct the subject to look at any particular point until the slide in the plate-holder has been drawn and

everything is in readiness for the exposure. Then, without further caution, and with no apparent exertion on your part, attract the attention of the subject by speaking, advising them to follow your eyes. While talking, at the moment the proper expression is secured make the exposure. Where a subject cannot follow your eyes an eye rest may be employed. Suggest that they look at it for a moment; then, when the expression becomes natural, instantly make the exposure. A pleasant remark from you at the same time of making the exposure will frequently add materially to the expression and likeness.

251. **Hair.**—Frequently a patron is displeased with proofs, owing to what they think is faulty arrangement of the hair. If the subject is a woman, careful attention should be paid to the back hair, or hair commonly called “scolding locks,” which are apt to protrude from the back of the neck. It is an easy matter and should not cause any annoyance to the subject, to gather these hairs back where they will not show.

252. Locks of hair hanging over the ear are easily arranged by passing the hand over the hair. Hair will easily submit to careful hand treatment. By observing such small details resittings cannot only be saved, but also a large amount of retouching and etching eliminated. Urge all subjects to dress their hair in the regular way; discourage any attempt at dressing the hair in a style different from the usual manner of fixing it.

253. With some masculine subjects the hair at the back of the parting stands up boldly, while with others the “cowlick” is the difficulty to be removed. These may be smoothed down by wetting just a trifle, and then using a brush vigorously. The hair always photographs more naturally when dry. To wet it excessively produces a gloss, which photographs white, causing a displeasing effect.

254. If the subject has a moustache, see that the ends do not droop too much; be sure it is divided properly. A beard should be carefully combed out. Attention should also be paid to the parting of the hair.

CHAPTER XV.

At-Home Portraiture.

Part VIII.

Important General Notes.

255. **Lens.**—The ordinary hand-camera lens may be employed for At-home Portraiture, but will be found to work rather slow. Beginners who do not care to purchase a better lens for this work will find the portrait attachment an added power. This attachment slips over the barrel of the regular lens, and can be obtained at a cost of \$1.50, or less. (See "Lenses.")

256. An anastigmat lens of the proper focal length gives most excellent portrait results, and at the same time serves as an all around instrument, being applicable to all classes of work. The focal length of the lens should equal the diagonal of the plate for which the lens is to be used. If it is your intention to make At-home Portraiture either a special feature or a business, the anastigmat portrait lens should be employed.

257. **Stopping Down the Lens.**—As the average lenses of the rectilinear and achromatic type have a sufficient amount of depth of focus to include all of the subject, such lenses should not be stopped down when used with a hand-camera. By stopping down the lens the depth of focus is increased, and as a greater depth of focus causes more sharpness throughout the picture space, the atmospheric effect is lost. Sometimes, when making photographs of full length figures, it may be necessary to stop down the lens,

because if a small opening is not employed some portion of the subject may be out of focus. In this case stopping down should be carried only far enough to produce a reasonably sharp focus.

258. *For bust work* always use the largest stop, even though focusing sharply on the face causes the back of the head to become slightly diffused.

259. **Softness in the Lighting.**—Always aim to secure softness in lighting, as results will not only be more pleasing, but the required length of exposures will be greatly reduced. Effects produced by the employment of a small source of light result in strong contrasts, and for this reason it is necessary to diffuse the light in such a manner as to reduce the density of the high-lights. In doing this the light throughout the room is diffused, and the general illumination, which did not exist before the diffusion of the light, very materially aids in the illumination of shadows, thus reducing the required length of exposure.

260. **Position of the Head.**—The face should be turned toward the source of light to a degree sufficient to obtain catch-lights in both eyes. The tip of the shadow cast by the nose must just touch the shadow of the cheek. Hence there is, practically, but one position in which the face may be placed if an absolutely true *Plain Lighting* is to be made. Turning the face too far toward the light will cause an excessive spread of illumination over the face, resulting in a flat effect. Turning the face too far away from the light, will produce heavy shadows on the shadow side, and the negative will contain an excess of contrast.

261. As a rule, in *At-home Portraiture* the camera should be placed as close to the line of the window as possible. In this position both ears of the subject may be visible on the ground-glass, presenting a full face view of the sitter. The position of the camera, of course, may be altered as well as that of the subject, to obtain the most pleasing outline of the face. For the average subject the camera should be placed on a level with the chin.

262. **Catch-Lights in the Eyes.**—The catch-lights in

the eyes being an exact reproduction of the source of light, are really the key to the lighting. If they are in proper position, the lighting will have been correctly made. A catch-light should appear in the upper corner of the iris of each eye; not directly above the pupil, nor at the side, but half way between these two points. This will indicate that the light falls upon the subject at the proper angle and, as the catch-light should not appear outside of the iris, the position of the head will be correct when the catch-light is in its proper location. If the catch-light is in the pupil of the eye it is evident that the face is turned toward the light at too great an angle. If it is in the white of the eye, it shows that the face is turned too far from the light. As a rule, in this latter position the catch-light in the shadow eye will be lost.

263. Relative Position of Face and Body.—The face and figure of the sitter give better lines when not placed in exactly the same direction. In making portraits of fleshy people, turn the body toward the light. This tends to lengthen the neck and apparently elevates the head from the shoulders. The neck of a slender person may be given a shorter appearance by turning the body from the light.

264. Pose of Figure.—For bust portraits of women or children the subject will appear better leaning forward in the chair, rather than backward. If, in a reclining position, the lines of the figure are not good, the waist line being bunched, with a more erect position, and the chest slightly extended, a more natural waist line may be obtained. A reclining position is more suitable for portraits of men, especially if they are of slender build. Leaning backward slightly gives the effect of stoutness; therefore men of excessive stoutness should sit more erect. If the lines are exaggerated they may be materially improved if careful attention is given to the trimming of the finished print.

265. Reflected Light.—The less reflected light employed the better. In fact, one should always aim to make the best use of the direct source of light, taking the light from but one direction. Reflected light is a secondary

source. The further the sitter is from the window, and the greater the diffusion of the direct source of light, the softer will be the shadows, requiring a decreased amount of reflected light. When it is necessary to further illuminate the shadows by means of reflected light, proceed cautiously, remembering that illumination of this kind should be simply a continuation of the direct source of light. Reflected light should not lap over the direct source of light, nor should it be thrown so strongly into the shadows as to cause the shadow side of the face to become as strongly lighted as the high-light side. Those portions of the face nearest the camera should be in strongest light, and from them there

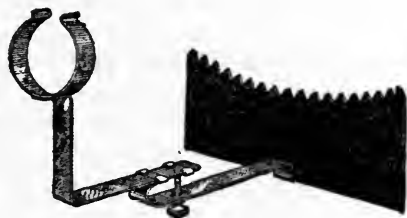

Illustration No. 15
The Morrison Vignetter
See Paragraph No. 266

should be a gradual blending as the contour of the face recedes. The ear on the light side of the face will, of course, be in much stronger light than that on the shadow side, yet the light on the former should be much more subdued than the illumination on the front of the face. Flatness and distortion would result if the reverse of this action were carried out.

266. **Vignetter.**—A vignetter is an appliance placed before the lens, which is used for cutting off undesirable foreground. In portraiture it is principally used for bust and two-third figures, where the lower portion is to be vignettted off. The “**Morrison**” vignetter shown in Illustration No. 15 is made to fit all hand-cameras. Owing to its compactness, it should be included in every home portraiture outfit.

With this vignetter photographic vignettes equal to professional work can be produced. It has all the adjustments of a vignetter for professional use, and can be made to produce the same results. The following description explains the method of its attachment to the camera, also the way to secure the various movements while examining the image on the ground-glass:

267. The up and down movement (by which the foreground is admitted or cut off, as desired) is secured by turning the thumb-screw, while the adjustment to and from the lens is obtained by a sliding friction mechanism.

268. Two cards are supplied, both sides of each being a different shade—varying from white to black—for the purpose of securing the exact shade to correspond with the drapery or color of the background. As will be observed in the illustration, the vignetter fits over the hood of the lens, being adjustable to instruments of any size. In using the vignetter the important points for consideration are: *First*, the adjustment of the vignetter to the position where it will cut off the required foreground; *second*, proper blending, as the shade of card in the vignetter must blend with the background; and *third*, the vignetter must be out of focus to give an even blend. After a few experiments it will be easy to manipulate the vignetter to produce any desired result.

269. **Exposure.**—Important though it is, exposure is often slighted, to the ruin of final results, even though the subject may have been excellently posed and lighted. Bearing in mind that under-exposure gives contrast, while over-exposure tends to produce flatness, it is still far better to err on the side of over-exposure, as it is possible to more easily control the development and secure a good image if detail is present in all portions. If the negative is greatly under-exposed, it is absolutely impossible to secure the desired amount of softness and detail in the shadows, no matter to what extent the plate is manipulated in the development. After the experience of a few trials, correct exposure should be ascertained and future work governed

accordingly. Remember, no consideration should be given to high-lights when exposing, but time entirely for the shadows, the proper exposure giving you the required amount of detail.

270. **Development.**—When developing, carry development only far enough to secure snappy high-lights. They will be of sufficient strength to hold up under the printing light, but not strong enough to produce a chalky print.

CHAPTER XVI.

At-Home Portraiture.

Difficulties—Plain Portrait Lighting.

271. **Handling the Diffusing Screen.**—A good plan is to experiment with the diffusing screen whenever it is possible to obtain a subject. Place the sitter in a chair, within about 3 feet of the light, raising and lowering the diffusing screen while watching the variation of light on the subject's face. Locate the subject at various distances from the light and manipulate the diffusing screen first with the curtains entirely closed, then partly separated, etc., noting the different effects. By experimenting at every opportunity you will soon be able to observe the most delicate effects, and within a reasonable time you will be able to manipulate the screen to produce any effect desired.

272. **Placing Reflector at Proper Angle.**—To overcome this difficulty practice placing the reflecting screen at a variety of angles, also at various distances from the subject, carefully noting the effects produced on the shadows. Always bear in mind, that the back of the head and the ear on the shadow side should be but slightly illuminated. Aim to reflect the light between the nose and the cheek bone on the shadow side.

273. Refer to the illustration of floor plan and observe the angle at which the reflecting screen should be placed. Frequently strong high-lights are subdued by reflecting light into the shadows, thus softening the contrast between high-lights and shadows. It is important that the reflector be placed at the proper angle, because incorrectly located it will be responsible for flatness instead of the desired roundness in the portrait. While the screen is placed on the shadow side, it must be located slightly in front of the subject to reflect light upon the fore-part of the shadow side of the face, permitting the light on the rear part of the head to gradually blend off into shadow. With practice you will soon learn to overcome many obstacles with the reflecting screen.

274. **Diffusing High-lights.**—When the high-lights are strong, the shadows are dense (black), and the result is a lighting full of contrast, to overcome which the light should be subdued. This must be accomplished through the manipulation of the diffusing

screen. It may be found necessary to use a double set of curtains on the diffusing screen; sometimes the pinning of a single sheet of newspaper over it will secure the desired result. Beware of over diffusion, as it produces flatness.

275. **Illuminating Background.**—To properly illuminate the background, the end furthest from the window, on the shadow side of the subject, should be turned toward the window at an angle that will cause the light to spread evenly over the entire ground. By this method the end of the ground furthest from the light will be evenly illuminated, and can be reproduced as it is painted. Experiment by placing the ground at different angles, carefully watching the varying degrees of illumination.

276. **Background Too Sharp.**—This difficulty occurs when rectilinear lenses are employed, as they are constructed in such a manner as to possess extreme depth of focus. In all portrait lenses this feature is eliminated, the depth of focus being greatly decreased, for when the subject is sharp upon the ground-glass the background is out of focus.

277. When the regular portrait lens is not used this difficulty with the rectilinear type of lens may be overcome by placing the background as far to the rear of the subject as possible. Make portraits with the lens as wide open as practical, without sacrificing definition. Another method is to unscrew the back combination of the lens one-half turn. This will secure softness. When small stops are used the background is usually wiry, so employ the largest stop that will permit the retaining of sufficient sharpness in the portrait.

278. **Heavy Shadow on Front of Shadow Cheek.**—This heavy shadow will not occur if the subject is placed on a line with the casing of the window, or even back of it. See dotted line A in Illustration No. 12—diagram of floor plan. If the reflecting screen is placed at an angle that causes it to reflect the strongest light on the ear and back of the head, instead of on the front of the face, effects of this character will be produced. Excessive volume of side light will also produce this effect. By placing the subject almost on a line with the window casing or even slightly back of it the sitter will receive full benefit of all the light from the window—and will be illuminated more from the front than the side, and the shadows will be soft and quite easy to control.

279. **Overcoming Reflection Caused by Sun Striking on the Window.**—If you have taken the ordinary precaution of stretching cheese-cloth or thin white muslin over the window, and then adjusting the diffusing screen, no trouble should be experienced. At times, however, if the sun strikes directly the light may be so strong as to cause some reflection and harsh high-lights. The

only thing to be done is to diffuse the light still more, until the proper softness (not flatness) is obtained. Placing the reflecting screen nearer to the subject will overcome extreme contrast.

280. **Posing the Subject.**—Follow carefully the advice given in the instruction and do not attempt fancy posing. The more simple the pose, the better. Observe that the body does not lean forward unnaturally, neither should the sitter assume a too reclining position, but one that suggests ease and comfort. By following the instruction regarding the placing of the hands, difficulty with round or sagging shoulders will be avoided.

281. **Catch-Light in the Eye Too Large.**—This difficulty generally occurs with subjects having large pupils. It is also caused by turning the face too far into the light. If the pupil of the eye receives the full strength of the light it will appear large, while if the face be turned a trifle farther from the window, permitting the light to strike the pupil on the side instead of the front, there would only be a small catch-light. By turning the face away from the light still more, the catch-lights disappear entirely. Be careful that the eyes are not directed too high or too low, nor should they lead the face too far. Extremely large eyes should scarcely lead at all, but be almost straight.

282. **Eyes of Subject Appear Staring.**—This difficulty is frequently caused by the subject gazing too long at the same object during the preliminaries of posing and lighting. The person may also be near-sighted, and the object at which the eyes are looking may be too far away. To surmount this difficulty, carefully follow these instructions. Watch the subject carefully, and by standing closer to or further from the subject, while they are looking at you, or by placing the eye rest at various points, you will soon observe the proper distance that will permit the eyes to rest naturally. Also permit the subject to wink as often as desired during the exposure. It is not advisable to have them look at the small object on the pole, but simply in that direction, for to raise the eyes up or down, or from side to side, during the exposure, would cause the pupil of the eye to become blurred. It is not advisable to tell the subject just where you wish them to look until you are ready to make the exposure.

283. **Closing of Lips Too Tightly.**—Never tell the subject to close the mouth or to open it; rather converse with them—get them to answer some questions, or finally suggest that they pass the tongue over the lips, to moisten them. The mouth will then assume a natural expression, and the exposure should be made instantly, before the mouth begins to twitch. Under such circumstances the subject should not know when the exposure is being made.

284. **Plate Developing Contrasty.**—This is either because the lighting was too contrasty—too strong a light causing deep shadows—or the plate was under-exposed. Light the subject so there will be even gradation from the highest lights to the deepest shadows. In making an exposure, time for the deepest shadows. Rather over than under-expose. In this way the difficulty can be overcome. A diluted developer is best for contrasty lightings, but the best plan is to light the subject exactly according to the result desired in the finished picture.

285. **Plate Developing Flat.**—This is the reverse condition to plate developing contrasty. In this case it is caused either by flat lighting of the subject or extreme over-exposure. Aim to secure proper lighting and exposure, and in either case treat the plate in development according to its exposure.

CHAPTER XVII.

At-Home Portraiture.

Part IX.

Rembrandt Lighting.

286. **Introduction.**—Preceding chapters have dealt with the photographing of subjects with Broad Lighting, the greater portion of the face being illuminated. Rembrandt Lightings are made, to a certain extent at least, in a similar manner, but the greater portion of the face is in shadow, and the high-lights and shadows are quite sharply defined. The subject is placed in practically the same position, the camera alone being moved further from the light. Most Rembrandt pictures are characterized by strong shadows and small areas of strongly lighted parts of the subject. The side of the face may have a preponderance of shadow and high-lights, being full and forceful, or darker notes of emphasis may predominate. This does not mean that the person's head must be turned so as to give a full side view of the face, with a strong light thrown on the outline of the profile and the rest of the face and figure void of detail. This is precisely what a Rembrandt portrait should *not* be. In making Rembrandt Portrait Lightings there should be gradual blending from the highest points of light into the deepest shadows, and even in these deep shadows there must be some detail.

287. There are, practically speaking, three distinct lightings of Rembrandt character practiced in photography: Full or nearly full face portraits with illumination from the

side; two-thirds side view with the face more or less looking toward the source of illumination; and full profile, in which the whole of the face is in shadow, only the outline receiving strong light. Sometimes this latter style is incorrectly termed Line Lighting.

Brief General Instruction.

288. In a Rembrandt Lighting the lights and shadows are very sharply defined, and usually the greater portion of the face is in shadow.

289. **Definition of Rembrandt Lighting.**—When lighting according to the rules of Rembrandt, care must be exercised to obtain the proper angle of light. The strongest light should fall upon the forehead, extending down the face and tipping the chin. The nose should be the dividing line of the light on the face. The light should not be too sharp and decisive. It should spread slightly across the nose and rest in a diffused form on the opposite cheek directly underneath the eye, on the shadow side of the face, thereby supplying illumination to that eye. The iris of this eye should catch a slight ray of light as it flows across the face, sufficient to produce a little catch-light. (See Illustration No. 16.)

290. Place the subject quite close to the light, and lower the diffusing screen sufficiently to soften the strongest lights. Make liberal use of the reflecting screen in this style of lighting, placing it as close as necessary to the subject, but exercise care that the strong reflected light is *not* cast on the shadow ear. Remember, reflected light should be simply a continuation of the direct source of light, and its function is to soften the harsh line which would otherwise exist between the strong high-lights and the shadows.

291. Study carefully Illustration No. 17. Note the position of the subject, the angle of light, etc., as well as the location of the camera, reflector and background.



Upper Illustration No. 16—See Paragraph No. 289
Lower Illustration No. 17—See Paragraph No. 291

AT-HOME PORTRAITURE—REMBRANDT LIGHTING



AT-HOME PORTRAIT

STUDY No. 9—See Page 402

MATHILDE WEIL

292. **Strength of Light.**—Different brands of plates require softer or harsher lighting of the subject; for instance, Seed, Stanley and Standard plates develop with a tendency toward softness, so the subject should be lighted a little stronger than would be necessary if employing Cramer or Hammer plates. Both of the latter work a little more contrasty, and, therefore, the high-lights may be considerably diffused and they will still develop with plenty of snap and contrast.

293. **Controlling the Light.**—The next point for consideration is the handling of the reflecting screen, as well as the diffusing screen. It is quite important that the reflecting screen be placed at the proper angle. Often you may observe portraits made after this style of lighting, where the shadow side of the face is as strongly illuminated as the front. This is a mistake, caused by the reflecting screen being placed at an angle which reflects light equally as strong on the cheek as on the fore part of the face.

294. **Diffusing Screen.**—Adjust the diffusing screen on the window, likewise the curtains, which can be separated at any point desired. Use this screen as a skylight, by raising or lowering it, or opening or closing any portion of the curtains. Drawing the curtains together at the bottom, allowing them to be partly separated at the top, will soften and diffuse the light on the drapery. If this light were not restrained the drapery would photograph more quickly than the face and hair, and would, when developed, either cause the face to appear much darker than the drapery, or if developing for the flesh, you would produce a very hard drapery effect, requiring a great deal of doctoring to make a good negative. Therefore, to avoid unnecessary labor light the subject as you wish the negative to appear when finished.

295. It is a good plan to close the diffusing curtains, thus softening the light, and then separate them sufficiently to supply the necessary "catch" or high-lights. You may be led to think that because you have diffused the strong lights by closing the diffusing curtains this will prolong the

exposure. Such is not the case. On the contrary, it tends to shorten the time, for should an open light be used without the diffusing screen, the shadows would be denser, requiring a long exposure to fully time them. While timing for the dense shadows the high-lights are sacrificed and

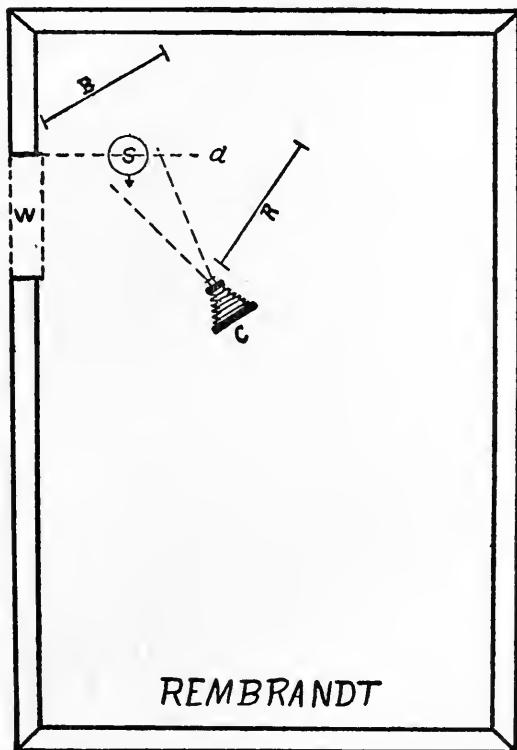

Illustration No. 18
See Paragraph No. 297

“choked.” By diffusing you equalize the light and illuminate the shadows, and as time must be given for the shadows they are not as dense after diffusion; consequently, less time is required for the exposure.

296. **Reflecting Screen.**—The reflecting screen is used

as an assistant to the diffusing screen. It aids in illuminating dense shadows, and must not be used too near the sitter. The nearer the reflecting screen is to the light the stronger will be the illumination reflected, and *vice versa*. Therefore, place the screen as near the light as is found necessary to supply the proper illumination to the front of the face. Gradually turn the end of the screen nearest the subject at an angle from the light, thereby reducing the strength of the reflected light—which illuminates the denser shadows—from this end of the screen. The angle at which the reflector should remain depends entirely upon the effect produced on the face of the subject.

297. Should the rear of the head, or the shadow portion of the Rembrandt Lighting, be illuminated to the same degree as the front of the face, you would experience the difficulty known as blocked or clogged shadows. Note in Illustration No. 18 (floor plan), the position of the reflecting screen. Observe that it is not parallel with the window, but at an angle of *about* 45° . The correct angle can only be judged by the strength of the light.

298. Carefully watch the light as it is reflected upon the subject; then, using the end of the reflector nearest the camera as a pivot, gradually turn the opposite end away from the sitter, but not so far that no light is reflected. It is necessary to produce enough detail to gradually blend the high-lights off into shadow. Only a little practice is required to thoroughly master the manipulation of this screen.

299. **Background.**—It is quite essential that you employ the proper background; one that is dark and gradually blended or a slightly clouded ground is recommended. This style of ground can be used for all classes of subjects.

300. The most important consideration in regard to the background is placing it in the proper light. It is exactly as essential that the background be illuminated as that the subject be, for the ground should carry out the idea of the lighting on the sitter. For this reason, when arranging the diffusing screen see that the background is properly illum-

inated, and place it as far away from the subject as possible to supply good atmospheric effect. For Rembrandt Lighting see that the light portion of the background is back of the shadow side of the subject, thus supplying relief to the shadows as well as to the high-lights.

301. **Exposure.**—In making these lightings expose to secure detail in the shadows, and give full time. Usually double the exposure is required for Rembrandt Lightings that is given for Plain Portrait Lightings.

CHAPTER XVIII.

At-Home Portraiture.

Part X.

Rembrandt Lighting—Detailed Instruction.

302. As only a small source of light is required in making front or two-thirds views of Rembrandt Lightings, it is fully as easy to produce these effects in the home as under a studio skylight. It must be remembered, however, that a small source of light always tends to produce contrast and harshness. For this reason great care must be exercised in diffusing the light sufficiently to secure a gradual blending between the highest points of light and the deepest shadows. If the light is not properly handled to produce softness, or if insufficient exposure to obtain full detail in the shadows is given, the high-lights will be so hard and so extremely chalky that, no matter how the developer is manipulated you will not produce a soft negative.

303. It is only by proper diffusion of the high-lights with sufficient illumination in the shadows, accompanied by correct exposure and accurate development, that the very best results are obtained. No matter whether Rembrandt or Plain Lightings are being made, if an extremely contrasty source of light is employed, and the shadows are not sufficiently illuminated, you will in almost every case suffer lack of detail in the shadows, no matter how far the negative is carried in the development. If carried beyond a certain stage, even with sufficient exposure the high-lights will become chalky, the shadows, instead of building up in detail,

will merely fog over, and the resulting print will be only a mass of black and white, with absolutely no intermediate half-tones.

304. Care must be taken that the face is not turned into the light more than sufficient to produce the proper effect of lighting, as the result will be large, strong catch-lights. Besides, by so doing, the light is allowed to spread to too great an extent over the face. Strong light also causes the pupils to contract and become small, and the expression is by no means as good as when the pupils are larger or more dilated

305. **Normal Rembrandt Lighting.**—To produce a full, or nearly full, face portrait in Rembrandt Lighting, place the sitter in exactly the same position as you would for Plain Portrait Lighting, locating the camera further from the light and viewing the subject from the shadow side. It may be necessary to place the subject a trifle closer to the light, this depending entirely upon the height of the window, as the light must fall upon the subject in exactly the same manner and at the same angle as for a Plain Lighting, which is about 45° .

306. **Diffusing Screen.**—The diffusing screen on the window is a very important accessory in correctly making Rembrandt Lightings. By employing it judiciously you regulate the strength of the high-lights, and require less use of the reflecting screen to illuminate the shadows. When direct rays of light enter a room, unobstructed, and fall upon the subject, they will produce extreme contrast, resulting in strong high-lights and dense shadows, with absolutely no half-tones. By gradually diffusing the source of light with the diffusing screen on the window, the white, chalky high-lights on the face will be softened. Diffusion of the source of light causes a more uniform distribution of the rays of light throughout the room. This actually shortens the required amount of exposure.

307. Equipped with a diffusing screen and a reflecting screen you have absolute control of the light. The diffusing screen can be adjusted to various heights, and if light ad-

mitted below the screen is too strong, it may be advisable to hang a piece of cloth (denser than the screen) underneath it. This will cut off, to a great extent, the rays of light which would otherwise come in at the bottom of the window. Drawing the curtains of the screen together at the bottom, allowing them to be partly separated at the top, will, as stated in the "Brief General Instruction," also assist in softening and diffusing the light on the drapery—the V-shaped opening permitting the strongest light to fall on the face.

308. **Light for Results.**—When the subject is dressed in white, if the light were not restrained as it falls upon the drapery, the highly illuminated drapery would affect the sensitive plate more quickly than the light on the face. When developed, the face would be much lighter than the drapery; or, if you developed for the face, a very hard, opaque drapery, requiring considerable dodging to make a good printing negative, would be the result. To avoid unnecessary labor, therefore, light the subject as you wish it to appear in the finished picture.

309. It is a good plan to experiment with the controlling of the light, as stated in the "Brief General Instruction," before attempting to make an exposure. The following experiment should also prove interesting and practical:

310. **Diffusing Experiment.**—Place a vase, cup, or any opaque object, before a window, and about one foot from it; hold a white cardboard back of this object, placing the object between the light and the cardboard. By placing the cardboard about 6 inches from the object, you will find the object will throw a very strong shadow on the card. Now, place a sheet of tissue paper between the light and the object, when the shadow on the cardboard will be very much subdued. This illustrates the effect produced by the manipulation of the diffusing screen. If desired, an actual photographic test can be made.

311. Make an exposure with the open light (all diffusing curtains having been drawn to one side). In this case give as much exposure as is deemed necessary to secure

detail in the deepest shadows, which, under the circumstances, will be very dense and will require about three times the ordinary exposure. Now make a second exposure, having properly diffused the light. Expose sufficiently to secure the proper amount of detail in the shadows, which, you will observe, are not nearly as dense as when the light was not diffused, thus requiring about one-half to two-thirds the exposure necessary with the former plate. Comparison of the two negatives will demonstrate the first to be extremely contrasty, the high-lights will be blocked, and the resulting print chalky. The shadows may have some detail in them, if sufficient exposure was given and the development carried far enough, but the chances are you will stop the development before any perceptible amount of detail has had an opportunity to develop. The reason for this is that the high-lights become so dense you will consider the negative fully developed.

312. With the second negative the conditions are entirely different. The development will proceed gradually, and if the high-lights have been softened by the diffusing screen they will build up in proper relationship to the other tones in the negative. By the time the high-lights have been sufficiently developed full detail will be present in the shadows, and all tones in the negative will be in proper proportion to each other, exactly as they appeared on the subject.

313. **Background.**—Dark backgrounds should be employed. Where a graded ground is used—one in which the tone blends from dark to light—it should be so placed that the dark end will appear back of the light side of the face, the light end being on the shadow side. The effect of contrast will in this way be accentuated, making the high-lights more forceful, the darks more rich. At the same time the actual contrast has not increased, but is kept within bounds; so with proper exposure the shadow detail will be recorded before the high-lights are over-exposed.

314. **Reflecting Screen.**—The handling of the reflecting screen for this style of lighting requires much more

careful attention than when using it for Plain Lightings, although the greatest care must be exercised at all times in securing just the proper amount of reflected light, and no more. However, you should make free use of the reflecting screen, placing it as close to the subject as necessary to obtain the proper illumination. Bear in mind, there should be no harsh lines existing between the high-lights and shadows. A gradual blending from the highest lights to the most dense shadows should be present.

315. The reflected light should, as previously stated, be simply a diffusion of the direct source of light. Therefore, the angle at which the reflector is placed is of vital importance. Flatness and, in fact, complete ruin of an otherwise good attempt at Rembrandt Lighting is the result of reflected light being cast too strongly on the shadow side of the face.

316. If one end of the reflector is nearer the light than the other, the end nearest the light will throw the strongest reflection. When placed at the proper angle it will cast the strongest reflected light onto the front of the face. From this it will be seen that it is essential to make various trials with the reflector in different positions, not only placing the screen at different angles to the light, but also near and distant from the subject.

317. A careful study should be made of the floor plan shown in Illustration No. 18, which gives the location of the subject, camera, reflecting screen, background, etc.

318. **Exposure.**—The exposure for Rembrandt Lighting requires approximately double that for Plain or Broad Lightings. As it is better to err on the side of over than under-exposure, do not hesitate to give plenty of time. From six to eight seconds is usually required, all depending, of course, upon the amount of illumination, as well as the speed of the lens employed. If an anastigmat or portrait lens is used, one to three seconds would be sufficient exposure when using the lens wide open.

319. **Developing.**—Negatives of Rembrandt Lightings are developed exactly the same as any other style of light-

ing, taking it for granted that they have received the proper amount of exposure. The shadows must be fully timed. If this is done the negative will develop evenly and the detail in the shadows will build up proportionately to the increase of density in the high-lights, and no difficulty should be experienced in producing a soft negative. If under-timed, decided contrast and weak shadows will be the result. On the contrary, if the negative is fully exposed, even if a trifle over-exposed, the addition of a drop or two of Bromide of Potassium, or the use of old normal developer, will enable you to easily control the development. It is very seldom necessary to restrain negatives of Rembrandt Lightings in the developer, for in many cases you will have under-exposures to deal with. The latitude in exposure in Rembrandt Lightings is much greater than with any other style of lighting. It is, therefore, permissible to give fully one-third more than the normal exposure, and yet produce good results.

320. **Side View Rembrandt Portrait.**—Rembrandt portraits, showing either a side or a two-thirds view of the face, are very popular for window lightings. They are made with the subject placed in exactly the same position as for the front view, the camera alone being moved further from the light to secure the proper view of the face. The contour of the subject's face governs, to a great extent, the position of the camera. A sufficient amount of the cheek on the high-light side of the face must be admitted to give roundness to the portrait and obtain the proper result, yet the position may be such as to obtain any view of the face, from the extreme front to the extreme profile.

321. **Special Illumination of the Shadows.**—The shadows may lack the required amount of illumination, in which case the reflector should be placed as near the subject as possible, thereby reflecting more light into the shadows, illuminating them in harmony with the high-lights. The same precautions must be taken in handling the reflector in this instance as when making the regular Rembrandt Lightings, bearing in mind that the object of the reflected

light is to give softness between the high-lights and the shadows, but under no circumstances must the shadow ear be as strongly illuminated as the cheek on the same side of the face.

322. **Practice Work.**—Having become thoroughly familiar with the instruction contained in this lesson and with the principles of Rembrandt Lighting, study carefully the various examples of Rembrandt Lighting effects in this volume; then proceed to pose a subject and make this lighting. When the effect is satisfactory make an exposure. Remember, that it will require about double the amount of time for a Rembrandt Lighting that is necessary to secure a correctly exposed Plain Lighting negative.

323. Develop the plate in normal developer, and observe its action. Does the plate develop evenly? If the high-lights appear stronger than they looked on the ground-glass, and the shadows hold back and do not build up in detail, the plate is under-timed. Immediately dilute your developer by adding an equal amount of water. This will reduce its action, and the developer will have more time to penetrate deeper into the emulsion, thus building up the shadows. A diluted Pyro developer is known as a soft working developer, for a negative in it gains detail in the shadows at a more rapid rate than it does density in the high-lights. Therefore, the high-lights of an under-exposed negative placed in a weak developer are actually restrained, while the shadow details are permitted to gain strength. When the high-lights are fully developed the shadows should have the required amount of detail.

324. Should the plate develop evenly—the shadows in the same relation to the high-lights, as they appeared on the ground-glass—you will know that the plate has been properly exposed. In case of under-exposure make another negative, giving more exposure to fully time the shadows. In fact, aim to slightly over-expose.

325. If the results of these first experiments are not satisfactory, proceed to make additional negatives. Observe the errors in your first attempts and try to overcome them.

When you finally obtain a good negative, make proof prints from each. Note on the back of the proofs complete data regarding your method of procedure. It might also be advisable to sketch on the back of at least one of the proofs, a diagram showing the floor plan, position of camera, subject, window, background, reflector, etc. Always state the exposure given each plate, the time of day, the kind of lens, etc. These proof prints should be filed in your proof file for future reference, and by studying the different prints carefully from time to time, you will avoid duplicating the same errors, and in a very short time be able to produce satisfactory results.

CHAPTER XIX.

At-Home Portraiture.

Difficulties—Rembrandt Lighting.

326. **Securing Sufficient Top Light.**—As the windows in many homes are quite low it may be impossible to secure a sufficient amount of top light to have the angle of light fall on the subject at an angle of 45° , unless the subject is placed quite close to the source of light. Remember, however, that this will give you more contrast unless you use double diffusing curtains. There must be softness and a gradual blending from high-lights to shadows in all portions of the figure.

327. **Too Much Contrast.**—Too much contrast is due to one of three things: (a) Having the subject too near the window; (b) insufficient diffusion of the light; (c) lack of proper reflected light. The remedies are: (a) Place the subject far enough away from the window to secure the correct angle of light. As a rule, the distance from subject to the window should be the same as the width of the window. (b) When using a north light there is little trouble in securing the proper amount of diffusion; but if a window is employed with the sun shining on it, it will be necessary to diffuse the light carefully with your diffusing screen, and perhaps also to add an extra thickness of cheese-cloth, in order to have the light under perfect control. (c) Should you be unable to properly soften the high-lights with the diffusing screen, and thus reduce the amount of contrast, it will be necessary to apply reflected light. This, however, must be done very cautiously and care exercised that too much light is not thrown into the deepest shadows on the back of the head and ear. Remember, that reflected light should be a continuation of the direct source of light. The object of reflected light is to simply blend the harsh line which is formed between the high-light and shadow and, in blending, the reflected light should become very weak as it reaches the back portion of the shadow side of the face.

328. **Diffusing High-Lights.**—If the high-lights are extremely hard and lack flesh values, the subject has been placed too close to the window, or you have not properly handled the diffusing curtains. The further the subject is away from the source of light

the more diffused will be the high-lights, yet placing the subject too far away from the window will cause too low an angle of light. Place the subject only far enough away from your source of light to secure the desired angle of light. A good rule to follow is to place the subject from the window the distance of the width of the window. Then close the curtains on the diffusing screen, and if this is not sufficient to give the desired diffusion and softness, use another thickness of cheese-cloth on the window. Sometimes a portion of a newspaper may be employed advantageously.

329. If your curtains are stained a light coffee color, you will not have any difficulty in obtaining sufficient diffusion, as the brown color of the curtains gives a mellow light. Being very soft in itself, and inclined toward flatness, be careful not to go to the extreme and over-diffuse the high-lights.

330. **Lack of Detail in Shadows.**—The improper handling of the diffusing curtains to diffuse the light and the improper use of the reflecting screen will cause lack of detail in the shadows. Under-exposure is also responsible for this difficulty. Remember, it is always necessary to give a sufficient amount of exposure to secure on the sensitive plate the detail which is in the deeper shadows. A negative which is under-developed and correctly exposed will also lack detail in the shadows. Such a negative will be improved by intensifying.

331. **Judging Proper Exposure.**—In order to ascertain the correct exposure it will be absolutely necessary to make a number of tests. If an exposure of two seconds is sufficient for Plain Lighting, where the major portion of the face is in light, then it is safe to give four seconds where the larger part of the face is in shadow. It is advisable to keep a memorandum of all exposures, time of day, conditions of light, complexion of the subject you are photographing, etc. Upon developing the negative, if you find it is under or over-exposed you should govern yourself accordingly the next time you make a negative under the same, or nearly the same conditions. Always make proof prints from each negative made, and note on the back of each proof all the data pertaining to its production, and by filing these proofs you have them for your future guidance.

332. **Reflecting Screen.**—Little or no difficulty should be experienced in handling the reflector, if the directions given in the lesson proper have been followed. Bear in mind that reflected light should be simply a continuation of the direct source of light. The reflected light should blend the harsh line which sometimes exists between the high-light and shadow on the face. Always have the reflector toward the front of the subject, never directly

at the side. By turning this screen first one way and then another, observing on your subject the effect produced, you will soon learn the proper angle at which it should remain. But be careful that the reflected light is not thrown so strongly into the deepest shadow on the rear of the head as to flatten the whole effect.

333. **Background.**—For Rembrandt Lighting effects the background is best when of a dark shade. When possible, however, it is advisable to place the ground so that the part directly back of the shadow side of the face will receive light from the window. In this way the general balance of the portrait picture will be correct, and the subject will stand out in relief from the background. A shaded background may be employed which will aid in producing this result.

334. **Too Much High-light on Shadow Side of Face.**—The face is turned too much toward the light; it should be turned away from the light until the shadow cast by the nose blends to some extent with the shadow of the cheek. There should be only a faint patch of light on the top of the cheek bone under the eye on the shadow side of the face.

335. **Room Too Narrow.**—When working in a narrow room, or in confined quarters, it may be necessary to place the subject closer to the window and strongly diffuse the light so as to reduce the harshness which would otherwise result from having the subject so near the light.

CHAPTER XX.

At-Home Portraiture.

Part XI.

Broad Profile Lighting.

336. **Introduction.**—Not all faces are suitable for profile lighting, for it is necessary that the outline of the profile of the face, to be pleasing, possess graceful curves. There are few who possess these qualifications and, therefore, the number of subjects who make pleasing profile portraits is limited.

337. **Points to be Considered.**—A profile portrait to be pleasing should not be made up of straight lines or angles; neither must one feature be out of proportion with the others, nor should the forehead or the chin recede too abruptly from the front of the face. Curved lines are always pleasing, and the more these predominate in the outline of the face, and the better the proportion of the various features, the more pleasing will be the profile outline.

338. **Shape of Profiles.**—Where the outline on the forehead, the nose, lips and chin presents straight lines, with angles at the root of the nose, the tip of the nose and on the chin, we have one form of objectionable profile. Another would exist if either the forehead or the nose or the chin were out of proportion to any of the other features. For instance, the forehead may be extremely high and its length be equal to the total length of the balance of the outline. If the forehead or the chin recedes very rapidly, the profile outline will be displeasing. The best shaped profile is one in which the length of the forehead, the length of the nose, and the distance from the nose to the tip of the chin are

equal and the lines forming each of these individual features are curved and not straight or angular.

339. **Placing the Subject for Broad Profile Lighting.**—When arranging the subject, place him as far from the window as consistent with the size of the light you have to contend with. Place the figure facing the light, at least partly if not entirely; then turn the face in profile from the light. Arrange the camera as close to the window as possible, so as to obtain a profile view of the subject's face without their turning the face too far from the light. In some instances, placing the subject with the back to the light, with the face turned over the shoulder towards the light, gives a very pleasing effect.

340. By varying the arrangement of light, as well as background, profile studies may be made giving a great variety of effects. It is, however, advisable to hold to one particular style of composition until that style has been thoroughly mastered, yet profile portraiture is one of those phases of photography which affords considerable variety and almost never ending change. One of the great attractions of the posing of faces in profile is, that the result shows character and portrays, to a great extent, the facial strength or weakness of the individual.

341. In full face studies we look more for a portrait, while in a profile study the aim is to secure the personality of the sitter.

342. **Pose.**—The first and most important matter for consideration is the way in which the head of the subject is posed. A tip of the head too far back or too far forward, leaning too much to the right or left, will make a wonderful amount of difference in the final result. The head should be held in a perfectly natural manner, as it is a very easy matter to exaggerate the neck of the subject, especially if of a lady gowned in evening dress or drapery. It is, therefore, necessary to be very careful as to the way in which you place the head.

343. **The Eyes.**—The direction in which the eyes are turned is another point which must receive attention—

turned too much downward the model appears dreamy, while if the eyes are turned too high a strained and staring effect will be produced, the neck being exceedingly exaggerated in length.

344. **The Lips.**—The lips contain a great deal of character, yet many times they appear to be glued fast and in such a position, are very unnatural. It is advisable to request your subject to moisten the lips with the tongue, which will restore their naturalness.

345. **The Position of the Body.**—The direction in which the body of the subject is turned is of equal importance to the posing of the head. The body should not be turned in the same direction that the eyes are looking. The lines of the shoulders and arms combine naturally with those of the neck and head, but this would not be the case if the body be placed squarely with the camera.

346. When focusing the image on the ground-glass be sure to provide for sufficient space for the subject to look into, and by all means avoid placing the head in the center of the picture space. This is extremely important and should not be neglected, for there is nothing so disagreeable as to see a face posed in profile with the nose almost touching the edge of the print. There must be enough space in front of the face to give your subject room in which to look.

347. **Lighting.**—Although the pose is an important feature, the lighting is very essential in many profile pictures in securing pleasing results. The direction from which the light comes and the manner in which it falls on the face, are all important factors; therefore, due consideration must be given to both the pose and the lighting. The most successful form of lighting in profile portraiture is that which draws into prominence the strongest characteristics of the face of a subject. Thin face subjects are best made with a broad light, as with it better modeling will be obtained. Subjects with round faces are best portrayed in the Rembrandt or Shadow Lighting. If a front light is employed for round faced subjects the results will very likely

be flat and give a very characterless portrait. As examples of portraiture the broad lighting effects on such subjects may not lack interest, but character studies will not be strong and convincing if the lighting is of this nature. For subjects with round faces which are also suited for profiles the strongest effect of relief is generally obtained by placing them in such a position that the light is slightly behind the plane of the figure, throwing the broad side of the face in shadow; or, as it is photographically termed, Rembrandt Profile Lighting.

Part XII.

Rembrandt Profile Lighting.

348. **The Lighting.**—A Rembrandt Profile Lighting is a profile view of the face, the outline being the only portion having a strong high-light. The rest of the face is in shadow except on the shadow cheek underneath the eye, where there is a small catch-light sufficient to supply illumination, giving roundness and clearness to this eye. In lighting the profile proceed exactly as you would for any other lighting. The strongest light should fall on the forehead, extending down the bridge of the nose, tipping the lips and chin, and finally blending into the drapery. This light should gradually soften as it descends from the forehead.

349. **Use Plenty of Light.**—Many make a great mistake when posing subjects for profile portraits, for they fail to avail themselves of the opportunity of using plenty of light and, consequently, their pictures present a mass of smudgy shadows with harsh high-lights for an outline, with no half-tone values present. The picture as a whole lacks the brilliancy which is so essential in profile portraiture. All this can be overcome and the necessary brilliancy obtained by the proper handling of the diffusing screen and making free use of all the light you have at your command.

350. You will observe in floor plan No. 19 how the subject, background and reflecting screen are located for producing this style of lighting. Owing to the fact that you are working against the light you, of course, do not

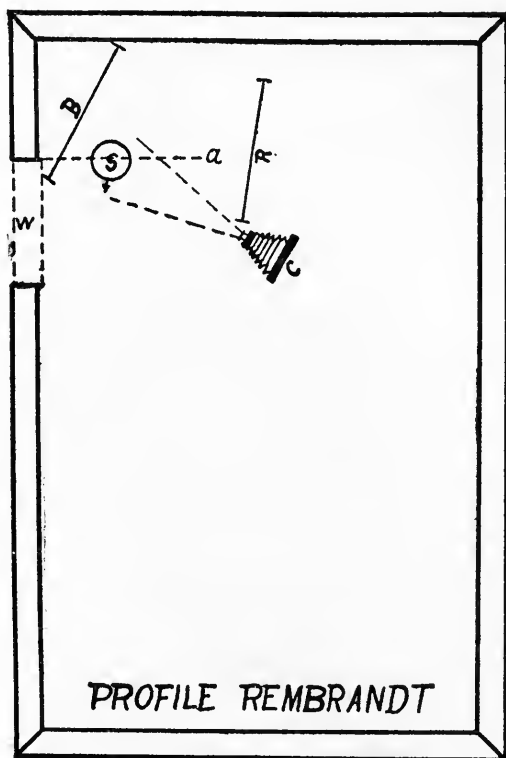

Illustration No. 19
See Paragraph No. 350

have as much general diffusion of light in the shadows as you would have in other classes of portraits, for there is no way of admitting light into the shadows from your source of illumination; therefore, the larger the window or source from which you receive your light the better. This is why, under the studio skylight, these lightings are very

much simplified, for under a large light plenty of illumination is available and all that is required is the proper controlling of the angle of light to produce the correct lighting, and less use of the reflecting screen is necessary; but, for one working by the ordinary window free use must be made of the reflector.

351. Proper View of the Face.—Perhaps one of the most important considerations in profile portraiture is the photographing of the best side of the face. In every subject there is what is known as the good and bad side, a right and wrong side of the face. By this we mean that the lines of the face are more graceful from one side than the other; there is more expression of character and the outline is more pleasing from the one side than the other. Usually the left side supplies the most character. The best side of the face is determined principally by the outline of the chin and forehead.

352. Proper Subjects for Profile Portraits.—A suitable subject may be determined in the following manner. Arrange your subject in profile pose and view the image on the ground-glass. Place a glass straight-edge on a line across the front of the face in profile, starting at the forehead directly over the eyebrow, extending through the nose, and touching the lower lip. The closer the entire forehead bends to this line the better; the nearer the chin comes within the range of line the better also. If the chin or forehead recede considerably from the line, the profile is bad. The more they recede the poorer the profile. The nearer they join this line the nearer perfect is the profile. See Illustration No. 20 of suitable subjects for profile portraits—the thin face subject in Broad Lighting and the round face subject in Shadow or Rembrandt Lighting.

353. Improving Profile by Proper Lighting.—The subject with a perfect profile may be placed in any position and under any style of light and will always present a good profile; but, while there are very few who really have a perfect profile, there are many whose profiles, if properly posed and lighted, can be improved and good profile pictures



Illustration No. 20

Suitable Profiles for Plain and Rembrandt Lightings

See Paragraph No. 352



THE CUP THAT CHEERS

STUDY No. 10—See Page 403

MRS. M. S. GAINES

made of them. For instance, we have some subjects with square, broad, flat chins. In lighting such a subject for Rembrandt Lighting, by turning the face from the light into the shadow only a trifle more than you would were the profile a perfect one, the high-light side of the square, broad chin will throw a shadow across the width of the chin, thus increasing its length. This is also true of the forehead where the forehead recedes—the more breadth you can admit into the view and yet retain the profile outline, the less curve it will show, thus producing a more square forehead than would be the case if made exactly the same as you would a perfect profile.

354. **Tipping the Head.**—By slightly tipping the head towards the camera we also gain a little length; that is, we apply some of the width of the face to the length, thus giving us more breadth to the profile. Many obstacles may be overcome by the simple turning of the head a little one way or the other, tipping it to or from the camera, raising it or lowering it. Each movement will show its effect and must be closely observed.

355. **The View of the Face.**—There are also times, as previously stated, where one side of the face presents a better profile than the other, for the reason that the qualities that are lacking on the one side may appear stronger on the other, for by their shape they project or recede more when viewed from one side than they would from the other. Consequently, all this must be taken into consideration when posing and lighting the subject.

356. Where you are working in the home by an ordinary window, unless the room is sufficiently large to admit of working from either end you will be somewhat handicapped for space in which to work, for where the profile style of picture is desired you may not always be able to take advantage of the best side of the face and yet light it properly in the small room you have at your command. For instance, you may have a subject with better lines on the right than on the left side, yet the room in which you are

working is such that you cannot shift the subject to the other side and have sufficient space in which to work your camera. You will, therefore, necessarily have to sacrifice the drawing and give preference to your facilities for lighting. This is not necessary when you have a large room and can work from either end of it.

357. As before stated, in the majority of cases you will find the left side of your subject will supply the best drawing. It is, therefore, advisable, when selecting a room for the making of your portrait work, that you choose one so located that your subject may be photographed from the left side.

358. In making this style of lighting place your background close to the side wall. It will be necessary for one end of this ground to be set very close to the window, and, perhaps, if you are working in a crowded place, you will need to have it lap over the window a foot or so. Place your subject in identically the same place as you would for an ordinary Rembrandt Lighting; that is, not more than two or three feet from the source of light, thereby making free use of all the light coming from the window to supply the necessary illumination. With your diffusing screen drawn to one side of the window, the illumination upon the subject may seem harsh and strong. If so, raise your diffusing screen and draw its curtains sufficiently to subdue the harsh lights. This screen (the curtains of which are made in sections) is so arranged that you may separate any portion of the curtains and admit any amount of direct light you may require. Care must be exercised in admitting your light through the screen that it does not extend beyond the profile of the face. Your strongest light, as before stated, should rest on the forehead, the next strongest on the nose, following down tipping the lips and chin, and finally blending off into the drapery.

359. **Illuminating the Background.**—It is essential that the background in this style of portraiture receive some attention. You undoubtedly have seen profile portraits where the face seemingly was sunk into the background instead

of standing out in relief. This is because the operator, in lighting his subject, paid no attention to the illumination upon the background, leaving it in total darkness. It is exactly as essential that the background be properly illuminated as the subject, for it supplies a part of the picture; therefore, separate your curtains on the diffusing screen in order to supply catch-lights on the subject, also separate them at the end of the screen next to the background. You will then, when securing the proper lighting effect on the subject, illuminate the background as well, giving good roundness to the portrait and supplying the desired background relief.

360. **The Reflecting Screen.**—You will find more use for the reflecting screen in making Rembrandt Profile Lightings than in any other style of lighting, for you have a larger area of shadow to illuminate. The reflector assists in illuminating the most dense shadows which cannot be reached by direct light. The greatest care must be exercised in the use of this screen, lest you overdo the reflection and produce stronger light in the deepest shadows than you have in the middle tones.

361. In the floor plan, Illustration No. 19, illustrating this lighting, you will observe the position of the reflecting screen, it being placed at an angle instead of facing broadside to the light. Should it face broadside to the light, the reflected light coming from this screen would be more powerful than the direct light and, therefore, the shadows, instead of blending off gradually as they approach the rear of the head, would be choked with a false light. By using this reflector at a suitable distance from your subject, and placing it at an angle so as to partly catch the direct rays of light, it will sufficiently accentuate the shadows. The reflected light will not be strong enough to intrude upon the shadows, but merely assist in producing the desired detail.

362. **Shielding the Lens.**—When making Rembrandt Profile Lightings, the camera, of course, is directed towards the source of light, and unless the lens is shielded from the rays of light you will be troubled with reflections, resulting

in fogged plates; therefore, the lens should be shielded with a hood or funnel-shaped cone, which is attached over the lens. This cone can be made of tin or of cardboard and should not be made shorter than 6 inches, the size of the cone depending entirely upon the angle of the lens. It must be wide enough at the mouth so that it does not interfere with the angle of the lens. The cone should be painted black, on the inside at least. Should it be painted a light color, you would be troubled with reflections from the cone itself—therefore some dead black paint must be used. Any black paint that will not give a glossy finish can be employed. (Detailed description for making a cone is given in Paragraphs 501-506.)

363. **Exposure.**—The exposure required for this style of lighting is a trifle longer than for ordinary Rembrandt Lighting, for the reason, as before stated, that you have a larger amount of shadow to illuminate and, therefore, require a longer exposure. You, of course, judge the amount of exposure by the appearance of the image on the ground-glass, and your judgment is based upon the appearance of the shadows, paying no attention whatever to the high-lights. In other words, calculate on an exposure sufficient to fully time the most dense shadows. This will require approximately double the exposure of an ordinary Rembrandt front or two-thirds view, and four times the exposure of a Plain Broad Lighting.

364. **Developing.**—There is no difference in developing Rembrandt portraits from any other style of lighting, for the difference in the illumination must be made up in the exposure; therefore you may apply the regular normal developer, and we particularly recommend the *Universal* formula given in Volume II. As previously stated, you expose for the shadows, and the high-lights will care for themselves. Should your negative show signs of contrast you will readily understand that the plate is under-exposed. If the high-lights and shadows develop in harmony with each other, exactly the same as they appear on the ground-glass, you will know that your plate is properly exposed and the

development can be completed in this bath. In case of slight under-exposure, the addition of more water will aid you in obtaining more detail.

365. **Practice Work.**—For your model select a subject having a profile which is not angular, but contains graceful curves. The face should be quite full, in order that the greatest amount of roundness and beauty of light effect may be obtained. Proceed to arrange your subject in exactly the same manner as required for the regular Rembrandt Lighting. If the outline of your subject is better from one side than the other, you, of course, select the best side. You may find that the subject has a very short neck and that the best position would be with the figure facing the camera and the head turned from it into the light. The subject sitting quite erect and the head slightly tipped toward the camera will give an easily held position. A good way to overcome the exaggerated appearance of an extremely long neck, when making a profile picture, is to turn the back of the subject to the camera, with the face toward the light, gradually turning the face from the light until the proper line of illumination is obtained. Should the light be too strong in the outline or high-lights, make use of your diffusing curtains, raising or lowering the screen until you have supplied sufficient diffusion to these high points of light. If entirely closing the curtains on the screen gives you too much diffusion, or flattens the high-lights, then separate them slightly, just sufficient to produce catch-lights that will give crispness and roundness.

366. With this accomplished turn your attention to the shadows. If they lack detail or sufficient illumination, then make use of your reflecting screen. Place this screen at an angle that will illuminate the shadows more strongly from the front of the face than the rear, thus permitting of the gradual blending away of the light into the deepest shadows.

367. Your attention must next be turned to the background. See that the background is properly illuminated. You may find it necessary to have this ground overlap the window a trifle in order to have it come outside the range

of the lens. With the background in place you are ready for the exposure.

368. Locate your camera in such a position as to secure the profile, or nearly a profile, of the face. If an exact profile was made, you would have what is termed a line lighting, which is not at all pleasing and does not give you the features of the face. You, therefore, want a trifle less than the profile and must admit into the view the full width of the bridge of the nose. This will give more roundness to the portrait. A good guide to follow is to turn the head towards the light until the eyebrow or eyelashes on the high-light side of the face are just out of range of the view. This will give you the full breadth of the forehead as well as the width of the nose, thus supplying the needed roundness to the portrait.

369. The camera is placed at a point from which you have viewed the subject when arranging the light, and in order to avoid reflections, shield the lens with the cone previously mentioned. When focusing on the ground-glass be careful that more space is allowed in front of the subject than in the rear. Never place a profile exactly in the center of the plate. Many times the exact profile view of the face is undesirable owing to the fact that the outline is too angular or the lines may be too straight. Should this be the case, move the camera around more towards the front of the subject, say about a two-thirds view, or until a pleasing outline is secured. Never select the position between a two-thirds view and a profile, for in doing so you will have displeasing angular lines of the cheek and only a partial view of the high-light eye, thus losing its shape and roundness.

370. When you have chosen a position which gives you the desired roundness make an exposure, bearing in mind that it will require, approximately, twice the exposure as for a front view Rembrandt Lighting. It is advisable after making the first exposure, to arrange your subject in a different position, yet carrying out the same lines of lighting. You may have posed them with the head drooped, or slightly tilted towards the camera. There might be another

view that would appear pleasing by raising the chin a trifle, or if the neck is quite long, lowering the head. A slight tilting, raising or lowering of the head makes a vast difference in the general appearance of the picture; therefore a large variety of effects may be obtained by slight changes in position.

371. After exposing a few plates, proceed to develop—using the normal developer—and develop these lightings the same as you would any other portrait. When the plates are dried, make proof prints from them, printing sufficiently deep to show all the quality there is in the negative. Note on the backs of these proofs all data regarding your method of procedure, being particular to note the time of day, the amount of exposure given, etc. File these prints in your proof file for future reference and for your next experiments be guided entirely by the results of your former efforts. They will serve as an excellent key for your guidance.

CHAPTER XXI.

Baby and Child Photography.

372. **Introduction.**—The actual cash returns for those who make a business of photographing children in their homes is a most attractive feature; while to those who desire to take up the work for their individual pleasure, and as a means of recording their own children in different attitudes, portraying their characteristics and securing pictures which are many times impossible for the professional photographer to produce, photography in the home becomes of invaluable service.

373. The father, mother, brother or sister, being perfectly familiar with the child subject, is better able to secure natural photographs of it in its different moods and attitudes than a professional photographer at the studio. The child is under no restraint whatever in the home and will assume most natural poses, while at the studio, among strangers and strange surroundings, it may become self-conscious and most unnatural in manner, and oftentimes unruly, either from fear or perhaps restraint. The many advantages of photographing children in the home are, therefore, very apparent.

374. The photographer who makes a business of photographing children, whether in the home or studio, in order to be successful must have a natural liking for children; otherwise it would be far better to leave this field of work entirely alone. One must be ready at all times, and under all circumstances, to do or say something that will interest the little subjects, for by this means their confidence is gained and held, which is absolutely essential if satisfactory results are to be obtained. Although the modern studio is usually equipped in a most perfect manner for the photo-

graphing of children, these little subjects appear more natural in their own home than in the studio, and for this reason the opportunities for obtaining a variety of interesting expressions and natural positions are far better. The principal requirement, aside from thoroughly understanding the manipulation of the instrument and the proper lighting of the little subject, is to gain its confidence, and with this accomplished the balance of the work is easy.

375. Comparing the two classes of persons who attempt to photograph the child in the home—the professional photographer and the amateur photographer—we find that the amateur who photographs his own children will invariably produce more pleasing pictures than the professional, as he understands his own children far better than any stranger, and for this reason he is able to secure expressions and positions that are perfectly natural, although his finished results may not be the best obtainable. But even this difficulty may be surmounted after a little practice and the application of the instruction which is to follow, as well as the instruction contained in the other volumes of this library.

Brief General Instruction.

376. **Principal Requirements.**—The principal requirement for the securing of portraits of children in the home is plenty of illumination. For infants the easiest and most simple method is to arrange them in a one-armed chair, commonly known as a three-cornered chair; or, a corner of a couch will answer very nicely. Place a sofa pillow in the corner and arrange the infant leaning against the pillow, and not sitting on it. Have it sitting quite straight. By means of such an arrangement as above mentioned it need not be fastened, for by placing it in the corner leaning against the pillow, the child cannot easily fall forward. In Illustration No. 21 is shown a series of infants' and children's pictures, very simply arranged, which are along the lines just suggested.



Illustration No. 21—See Paragraph No. 376
Series of Infants' Pictures



Illustration No. 27
See Paragraph No. 435
Group—Pyramidal
Arrangement



Illustration No. 28—See Paragraph No. 436
Group—Pyramidal Arrangement

“FAIRY TALES”



377. For children from one to five years of age a sitting or lounging position will be found most suitable, and such subjects are best handled when given something to do—some toy to play with, a picture book to look at, etc. Where toys are employed the subject may be arranged on the floor near a window. If picture books are used a lounging position on a sofa or large chair is best, or a table may be worked in as an accessory, with the child leaning on the table, etc. Any position that seems careless and natural cannot help but please.

378. **Lighting.**—As previously stated, supply all the light possible, and while ordinarily a room with a northern exposure would be preferred, yet where the sunlight falls upon the window, with its angle in the direction of the space to be occupied by the subject, you will have stronger illumination, and if the sunlight does not come within the picture space it will do no harm. The light will be very much diffused by tacking a sheet of white muslin over the window, and the subject may be placed quite near without any harsh effect.

379. **Plates to Use.**—None but the most rapid plates should be employed for children's portraits, enabling you to make reasonably quick exposures and obtain expressions which could not be secured if slow plates, requiring long exposures, were employed.

380. **Exposure.**—The required exposure will depend upon the strength of illumination, also the speed of the lens employed. Use the lens at its largest aperture, thus allowing for the quickest possible exposure, which will vary from one-half second to two seconds, depending on the light and the speed of the lens.

381. **Development.**—Use any developer. The *Universal Developing Formula* given in Volume II is recommended, but as exposures made under such conditions are very apt to be short, double the amount of water should be added to the regular formula. This will give you more detail and a softer negative.

CHAPTER XXII.

Baby and Child Photography.

Detailed Instruction.

382. When photographing children there are many little details that are commonly overlooked, yet are very important for successful portraiture. While you may have good illumination, and even natural, easy positions of the little subjects, they may lack something to make them entirely satisfactory, unless care has been taken throughout all the manipulation.

383. As stated in the *Brief General Instruction*, first attention should be given to the selection of a portion of the room supplying the best light for the kind and style of a picture you expect to make. With this settled, observe the kind of a background you will have for your subject under such conditions. The background should not be white, neither is it advisable to have it black nor very dark. A neutral tint is best, it being more in keeping with the subject.

384. Where dark furnishings predominate in the home, these may be broken by means of portieres, draperies, sofa pillows, etc., of a more neutral tone. Any of these articles properly arranged will tend to neutralize the tone and overcome the decided contrast which is very undesirable. The admission of a portion of a window in the view will, many times, improve the effect of the picture, and give it more of an appearance of home. So, before placing your subject observe the amount of space that will be included in the picture, and make your alterations accordingly. All such changes must be made to appear natural and careless, and

be entirely void of the appearance of being placed there in a stereotyped form expressly for the picture. While making these arrangements you must have in mind about the kind of a picture you are going to make, whether sitting, kneeling or lounging on the floor, or arranged in a chair, couch, or at a table, etc. This must all be considered. This accomplished you are ready to set up your camera.

385. **Arranging the Camera.**—The arranging of the camera is a very important consideration, for if the camera is too high it will make a marked difference in the resulting picture. Where a child is seated on the floor the tripod must be lowered as much as possible, so as to keep the lens on a level with the eyes of the subject. Where they are arranged at some elevation the camera must be raised accordingly. A good rule to follow is to keep the lens as near on a level with the eyes of the subject as possible, and for Plain or Broad Lighting place the camera as close to the source of illumination as convenient. The closer you can work to the light the better, as this will allow a broader light on the subject.

386. **Lighting.**—Plain Broad Lightings are best for children, and they should be arranged so that the light falls from the side and front. The side light supplies sufficient shadows to give roundness. The front light combined with side light gives more general illumination. A front light alone, or, in other words, the subject facing square to the light, will give you flat results. So aim for some side light, and where the subject is gowned in white arrange the figure turned slightly from the light so it will not fall broadly upon the drapery. This will throw the dress into slight shadow, thus producing softness to the drapery; while roundness will be given to the face if it is turned more toward the source of light. For black drapery you may invert this order, thus permitting the black goods to receive full illumination, and by turning the face slightly from the light you will give a better balance to the picture.

387. **Spacing.**—When observing the image on the ground-glass always provide for sufficient space in front of

the face, thus supplying space for the subject to look into. If placed in a lounging position the feet may come close to the edge of one side of the picture space, but the head should not come anywhere near the opposite edge of the space, but may occupy a position slightly beyond the center.

388. **Posing the Child.**—No greater mistake can be made than to attempt posing a young child—every action should come from the subject itself. To attempt posing the little one out of its own natural attitude would result in failure. Little girl subjects may be well handled playing with a doll, a toy piano, or similar toy. A boy will be interested in a picture book or some boy's toys. Avoid large articles, as they detract from the portrait. A few simple toys are not objectionable, but many good results may be obtained without them. As children naturally assume very graceful, easy positions of their own, with a little coaching and observing some of their characteristic attitudes, you will be able to produce very interesting pictures.

389. **The Light.**—One should aim to have as strong a light as possible, so the exposure may be made very quickly. Use all the light obtainable, yet do not have it too harsh. If the source of illumination is somewhat small, you should diffuse it slightly by pinning a small piece of cheese-cloth across the window, or at least the lower half of the window. See that the child is reasonably in range of this light; in fact, it would be better if placed in the center of the strongest illumination.

390. A reflector may be required to assist in illuminating the shadows. Before placing the subject in final position, locate your camera and obtain a focus on the ground-glass. Insert the plate-holder and be ready to make the exposure at the opportune moment. If you possess a good rapid rectilinear or anastigmat lens you should not stop it down to any extent. With good light conditions and using the lens wide open the exposure may be made as quickly as you can press the bulb and release it. The exact exposure required can only be ascertained by experiments.

391. **Accessories.**—Careful attention should be paid

to the accessories, and if you have any doubt as to the value of the admission of any article into the composition, remove it. Do not include in the picture any accessories which have not a direct connection with or do not improve the composition.

392. The high chair, the cradle, the little chair or stool, the rocking-horse, a toy piano, a little table (on which may be spread a luncheon), and an endless number of miniature accessories and toys may be advantageously included in the little portrait to very materially assist in securing an interesting child study. By no means admit too many of them, however, in a single picture. Amidst these surroundings the child will appear perfectly at home, and its expression will be more natural.

393: When toys are employed do not have them arranged so they appear too conspicuously. When large toys are used place them to one side of the subject—never in front of them—for all articles in the foreground will be exaggerated in size and appear too prominently. If used in the background, or even at the side, they will appear less conspicuous and will not detract from the portrait itself.

394. **Dress.**—Children photographed in the home should be dressed in keeping with their surroundings. If they are to be photographed with toys, they will naturally look better in their romping clothes than if dressed in their very best garb. If photographed for the sake of the portrait and no toys are admitted, then they should be gowned in keeping with the style of the portrait to be made. Usually, however, portraits of children in the home are valued more when made as the little ones appear when at play, or as they are seen throughout the day.

395. When a child is taken to a professional photographer's studio it is invariably clothed in white, and its best dress is used. It is perfectly natural that the mother should insist that the child's picture be taken this way, but this class of picture appeals to the parents only as a portrait, while the picture taken in the home appeals to them more, owing to the natural surroundings, and because the child

is portrayed as they are accustomed to seeing it. A conventional style of picture made in the home would, therefore, be uninteresting and unappreciated.

396. **Obtaining Expression.**—The obtaining of proper expression is one of the principal difficulties connected with photographic portraiture. The proper expression is controlled entirely by the photographer, who must have perfect control over his little subjects, so that whatever he does or says will interest them. Having obtained the desired expression, the making of the exposure must be done quickly and at a time when they are not moving about. To become expert at this requires practice. Even with children who are quite mischievous and move about considerably, there is a time when they are quite still for a moment, and this is the instant the exposure should be made.

397. By experience you will observe, when you have the close attention of a child, that there is a time, just before you are about to say something, when it has an expression of expectancy, which causes it instinctively to be quiet for an instant. This is one time that the exposure can be made. There is another time, immediately after you have done or said something which pleases the subject—about the moment it is sobering down and before it has become completely sober—when the exposure should be made. In the one case you get a more quiet attitude, in the other you obtain an expression of expectancy, the severity of which must be controlled by the manner of amusement or entertainment.

398. **Entertaining Children.**—The secret of amusing or entertaining children, in order to obtain expression, lies in the simple manner of entertainment, which must be such that they can comprehend instantly what you are doing and see the amusing side of it at a glance. To employ any method beyond their comprehension, even if only slightly so, will give them a wondering expression, which will result in a stare, which is unnatural. One can do no better than to practice simple methods for obtaining expression. This will prove of real value for successful At-home Portraiture of children.

CHAPTER XXIII.

Children's Portraits in Drapery.

399. Children from two to twelve years of age lend themselves admirably to the securing of drapery pictures. The photographer with some idea of lines and composition (which are quite essential for the successful draping of his little subject) will, with a little care, be able to secure some very beautiful effects. By the carefully careless arrangement of simple drapery the interest of such portraits is centered in the face, where it properly belongs, thus making this class of pictures more artistic and always to be admired.

400. **Class of Goods to use for Draping.**—Any soft goods may be employed for draping. The best material, however, would be a delicate chiffon, of a pink color. Never use blue. Pink and a delicate Nile-green are the best for all-around purposes. From two to three yards will be sufficient for any purpose in which you may require its use.

401. **Arranging the Drapery.**—Apparent carelessness should be at all times introduced in fixing the drapery, for set arrangements are undesirable and should always be avoided. If the drapery is drawn tightly about the figure the child will appear uncomfortable and difficulties will be encountered in securing a pleasing result, while if the drapery is arranged loosely and fluffy, more soft and dainty effects will be secured. When draping your little subjects exercise care that the drapery is arranged in soft folds, and not perfectly flat, for the folds in the drapery supply your lines, which are important in the making of the picture. Without these folds you would have no high-lights or shadows, and the result would appear flat, which is very undesirable. Many times the drapery may be arranged in

a manner that will assist in breaking up the straight parallel lines which frequently run from the shoulders toward the front of the figure.

402. The drapery shown in Illustration No. 22, as you will observe, has been carelessly arranged over the the one shoulder and underneath the other arm, with the ends of the drapery loosely gathered in the right hand and held before the little subject, thus supplying an easy, graceful position of the hand, and also giving a careless and unpretentious arrangement of the drapery. By this arrangement the lines from the shoulder have been partially covered and broken, while the new lines formed have pleasing curves and angles, which give a more pleasing effect.

403. Where a child has long or curly hair, it should be placed about the shoulders, hanging loosely, and arranged in such a manner as to break up straight lines. If the hair has been curled these curls should appear loose, and not be allowed to hang straight and stiff, for in such a position the edges would form parallel lines. Where the hair hangs over the shoulders the ends should slightly curve inward, and not outward.

404. **Posing the Hands.**—Children usually unconsciously assume very graceful positions of the hands. They are not conscious of posing for a picture, and, in consequence, almost any turn or fold of the little hand is void of any attempt at posing. While many little ones, placed before something upon which they can rest their arms, will unconsciously fold their hands in some graceful attitude, there are others, however, who may be a little backward but will very readily assume a position of the hands with a little coaching. A good way, under such circumstances, to obtain a perfectly natural pose of the body, head and hands of children, is to show them by assuming the desired position yourself. Then, with a little assistance from you, they will take the same position. In many instances they will drop into it in a graceful, natural manner, and you will have but little correction to make in obtaining the



Illustration No. 22
Child Drapery Portrait
See Paragraph No. 402



Illustration No. 24
Statuette
See Paragraph No. 408



Illustration No. 23
Hand Posing
See Paragraph No. 406

pose desired. A few words of encouragement during these moments will bring them in closer touch with you.

405. The posing of the hand in children's portraits—especially when the children are garbed in dainty drapery—aids considerably in producing artistic results, as the arrangement of the hands adds to the drawing of the finished portrait. Of course, all children are not graceful, and those who lack this quality should not be posed in such positions as would seem unnatural. Children should be portrayed as they really are. A child void of grace should be photographed as simply as possible—any other attempt would be fruitless.

406. In Illustration No. 23 is presented a very simple, and yet artistic, specimen of hand posing of a child clad in drapery. The material was carelessly arranged about the body, falling over one shoulder and underneath the arm of the other. You will observe that the drapery falls over the shoulder on the high-light side of the face. Where one shoulder is to be bared always have this shoulder in shadow. If the child is plump and of good form, it is advisable to drape below the arms, exposing the breast. Do not draw the chiffon tightly, but, on the contrary, arrange it very loosely, so it will appear soft, dainty and fluffy. By draping the chiffon in folds, one fold crossing and overlapping the other softly, you will produce this effect and supply shadows and half-tones, without which the drapery would appear hard and flat.

407. **Lighting.**—The lighting is very important in drapery portraits for the light must, in a way, fall across the subject, and not fall from the front. A cross light will give snap and roundness, while a front light, where drapery is employed, will result in flatness. Therefore, place the subject so as to receive the light from the side, and only partly from the front.

408. **Statuettes.**—The almost perfect forms of some little children, between the ages of two and five years, make most beautiful statuette pictures, and many interesting studies may be made of them. These little subjects are

usually best photographed in a standing position, and, while they may be photographed entirely nude, a tiny bit of drapery gathered in one hand, draped across the trunk very carelessly, will aid in breaking lines and will not detract from the subject itself. (See Illustration No. 24.)

409. Sitting positions may also be made of them, but they are not so attractive, and do not show their little forms so well. The best effects are obtained by placing the child on a white pedestal, or some small object to give it a support on which to stand. The figure should be so turned as to give the most pleasing lines of composition. The body is best posed when at an angle to the camera, but broad-side to the light.

410. The arrangement of the feet is of considerable importance. Both should not be the same distance from the camera. The attitude of the subject will determine exactly the position they should occupy. One should avoid the duplicating of lines or giving exactly the same positions for either hands or feet.

411. A black background should, of course, be employed, and the ground turned away from the source of light to keep it as dark as possible. The body of the subject should face the light, to receive full illumination, and the exposure should be made as short as possible. The object of the short exposure is two-fold. *First*, the little subject cannot hold an attitude for any length of time. Therefore, an exposure not to exceed a second or two should be given, and the illumination should be sufficient to enable you to make exposures in this time. *Second*, if too long an exposure be given there is danger of halation around the white figure and drapery, contrasting, as it does, with the background.

412. Many times it will be necessary to etch away the effect of halation around the figure, and perhaps remove the film comprising the background, in order that this may be made perfectly black. This is done by scraping away the film with the etching knife, instruction for which is given in Volume X.

413. Never start to etch away from the outline of the figure. Begin about one-sixteenth inch from it, and after cutting away the background entirely, then, using the rounded edge of the etching blade, work in toward the figure outline, for in this way you secure a soft blending; whereas, by starting to etch away from the outline itself a white line would result.

414. Your first efforts should be devoted to simple positions, always having in mind the attitudes you expect your little subject to take. Strive to carry out these ideas in the picture. Working in a haphazard manner, with no particular aim or idea in view, will invariably result in failure. It is, therefore, advisable to first train your subject beforehand, before undressing it, practicing different attitudes, and when the child seems to understand what you require, prepare it for the position. Work as rapidly as possible, for the little subject becomes tired very easily and you lose the life that should be injected into such a picture.

415. In Illustrations Nos. 21, 22, and 23 we supply some suggestions for suitable positions for infants and children. The infant's picture shown in the lower row of the picture in Illustration No. 21 will give you an idea of the arrangement of the pillow for supporting a baby. The upper row of pictures in this same illustration offer some suggestions for pictures of older children, and Illustration No. 23 supplies a very simple study for hand posing, while in Illustration No. 24 we present a statuette portrait, very simply posed and easy to produce. These examples we trust will serve the purpose of supplying suggestions of simple positions that may be employed for child portraiture.



CHAPTER XXIV.

Photographing Children Outdoors.

416. **Introduction.**—Some exceedingly interesting pictures may be made of children in the open light. A child picking flowers, playing with a garden rake, digging in the sand, attempting to push a lawn-mower, or any mischievous work for a child, will form interesting pictures, if taken when the subject is unconscious of your presence. Such pictures can be made in bright sunlight, and, of course, with a hand camera. Pictures of this nature are not made for their portrait value, but for the record of the characteristic attitudes and expressions of the little one that cannot be obtained in any other way.

417. Where it is desired to make pictures outdoors for their portrait values, the subject should not be placed in direct sunlight, for the strong light will cause the eyes to squint. Select some location in the shade, but do not attempt to make an exposure under trees which permit patches of bright sunlight to come through the branches, and perhaps fall upon the subject. It is best to work in the shade of the house, or on a porch, for in either of these places you will have plenty of illumination and should be able to make very short exposures.

418. Never have the subject facing in the direction from which the sun is shining, for even in the shade the sun will cause the subject's eyes to squint; while if facing in the opposite direction from which the sun is shining the

eyes will rest more easily and appear more natural, when good expressions may be obtained.

419. **Use of Hand Camera.**—If the background surrounding the child is not dark, and if your lens is a rapid one, you will be able to hold the camera in the hand and with an exposure of 1-25 of a second, using the lens without a stop, make a fully timed negative. This requires a very fast lens. The ordinary lens attached to most cameras is not fast enough to allow one to hold the camera in the hand, as with such a lens an exposure of perhaps one-half second will be required. In a case of this kind it will be necessary to rest the instrument on some firm support—an ordinary chair or table, but better still your regular tripod. If the child is moving about to any extent, in order to avoid error in focusing and yet secure a sharp image, stop the lens down to f. 8. You will then have the subject sufficiently sharp, even though it should step a foot or two out of the line of sharpest focus, and a quick bulb exposure will be sufficient.

420. **Securing Expression.**—To secure the most natural expression, the child should not be conscious that the picture is being made. Usually the most successful results are achieved when you have an assistant to help you keep the child entertained. While the little one is engaged at play you must watch your opportunity to make the exposure at a moment when it is not moving. This will, of course, require patience, and perhaps several attempts, but if out of a half dozen exposures you obtain one excellent picture with natural expression, you will be amply rewarded for the pains taken. Two excellent examples of Outdoor Photography are shown in the lower picture of Illustration No. 7 (see page 69), and in Illustration No. 25.

421. **Developing.**—The *Universal Developing Formula*, given in Volume II, will render excellent results, but when quick exposures are made, such as are required for children's pictures, the normal developer should be diluted with double the amount of water. Care must be ex-



Illustration No. 25
At-home Portraiture Out-of-doors by Henry Havelock Pierce
See Paragraph No. 420

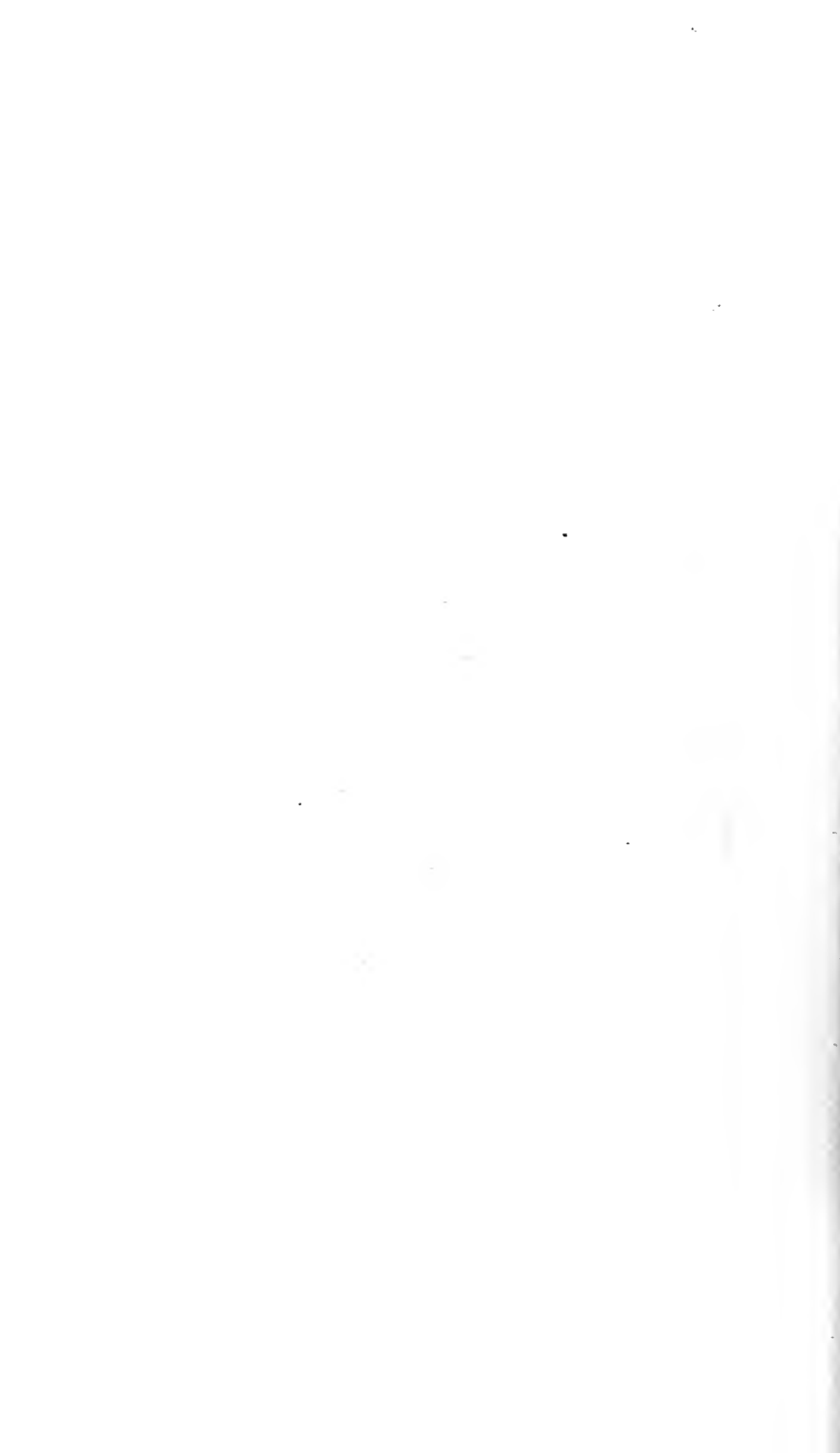



AT-HOME PORTRAIT

STUDY No. 12—See Page 403

PERRY STUDIO
Allegheny, Pa.

exercised that you do not over-develop the negative, for in doing so you flatten the high-lights and make them appear chalky. When developing light drapery it should be carried a trifle farther than dark, yet to develop a plate too far means that you lose the soft delicate effects. If, by accident, you do over-develop, the plate may be reduced by immersion in a bath of Persulphate of Ammonia. (See Reducing, Volume II.)

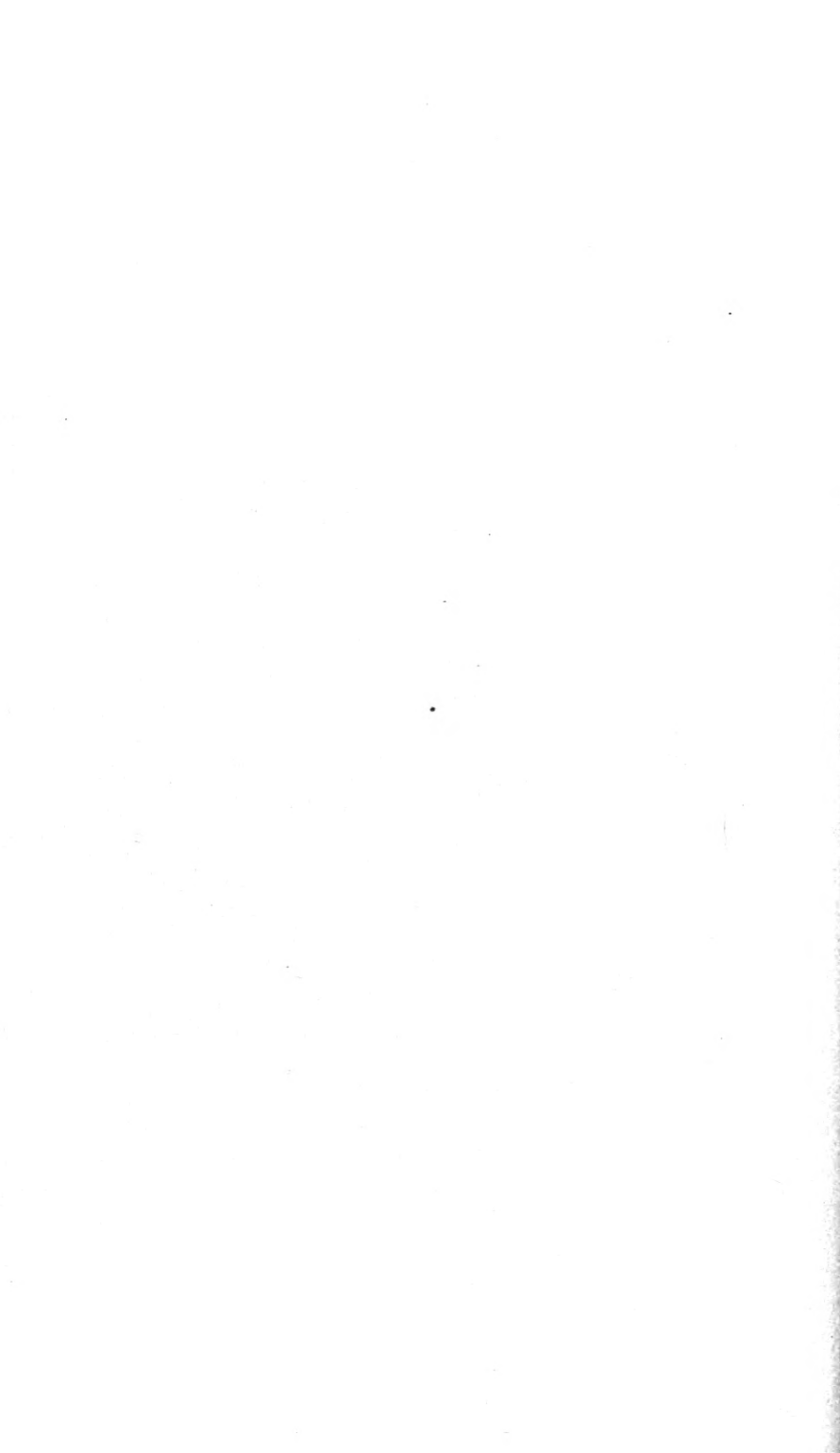

CHAPTER XXV.

Firelight Effects by Daylight.

422. **Introduction.**—In addition to the regular forms of lighting, there is an endless number of striking and odd effects which may be produced by daylight as well as artificial light. When it is possible to use daylight it will be found far easier, and, as a rule, the results will be better than when employing flashlight, or any other form of artificial light. The greatest drawback of all, when using flashlight material, is that the lighting effect cannot be studied carefully previous to making the exposure, even if an experimental flash is used beforehand. The flash is so sudden that there is no time to see what light strikes the subject, or what undesirable reflections may be cast from any accessory that may catch the light. If noted in time the accessory might have been easily removed, or turned at a different angle so as not to catch the light. When daylight is employed as the illuminant, the light is continuous and steady and will give you sufficient time in which to study your subject and to make alterations until you have secured exactly the desired effect.

423. One of the easiest, and perhaps most interesting, features of this class of work is the making of firelight effects by daylight. It is a very easy matter to control the light and on referring to Illustration No. 26 the method of procedure will be clearly understood. The subject is raised to the level of the window-sill, using a large table or boards supported on trestles. This platform should be covered with a carpet, which may be thrown loosely over it. The opaque curtain on the window should be drawn down from the top far enough to give an opening of suitable size to produce

the proper effect. The size of the opening will depend entirely upon the position of the subject, etc. An artificial fireplace must be constructed and usually a fender, andirons, and tongs may be secured from a local hardware dealer. This fireplace should be placed in front of the opening in the window on the temporary floor. The subject should be as near the source of light as possible, so that the light may be concentrated and produce the slight harshness which will make the scene appear natural. The remaining curtains in the room should be drawn, as the only light desired is that coming through the small opening in the window you are using—just in front of the sitter where the fire is supposed to be. In some cases it may be found convenient to place a mirror or a white piece of paper in the “fireplace” to give an extra amount of reflected light upwards into the face of the sitter.

424. This method of lighting has advantages over the use of flashlight compounds, in addition to those previously mentioned. The usual method of placing magnesium or a flash-powder of some description in the ordinary grate, is always attended by a certain degree of smoke and dirt. Great care must also be taken to avoid flare around the fireplace when employing this latter method.

425. The background must be black and may be composed of very dark curtains if nothing more suitable is at hand. These should be stretched tightly, otherwise awkward streaks of light will show on the folds. An example of a fireplace study is shown in Illustration No. 26, and this will give you an idea of the effects which are easily obtained.

426. **Exposure.**—The exposure should be rather too little than too much, as sharp detail is wanted only on the face. A rather contrasty negative is best suited for this class of work. Of course the actual exposure will vary according to many prevailing circumstances, but if you have about four square feet of light with the subject placed three or four feet from it, using the lens working at *f.* 8 and a fast plate, the approximate exposure will be three seconds.

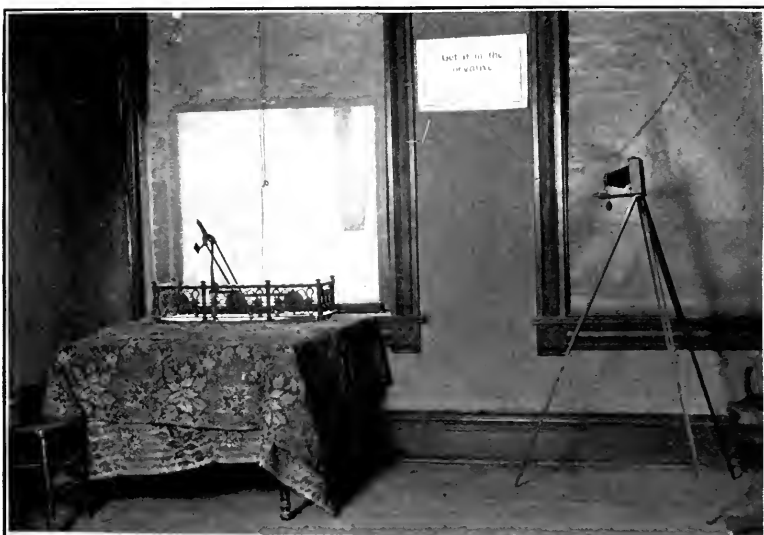

Illustration No. 26
Fire-light Effect by Daylight
See Paragraphs No. 423-5





MAKING PAPER DOLLS

STUDY No. 13—See Page 403

FRANCES B. JOHNSTON

427. **Development.**—The development should be carried until the high-lights have attained good printing density, and no attention be paid to the shadows. The Universal Pyro formula given in Vol. II is the best to use; for with it the high-lights are not so likely to clog up as when Hydroquinon or similar developers are employed.

428. **Printing.**—The most beautiful effects are obtained by the carbon process, the carbon tissue (a Black or Vandyke Brown) being printed in the regular way and an orange color paper used for a support. This orange color gives the effect of fire. Good effects are obtained on Platinum and other printing-out papers, while Royal Velox will also give good effects, as the body of the paper is of a cream color which helps to carry out the idea of firelight.

429. **Practice Work.**—The making of firelight effects by daylight is no more difficult than the producing of regular portraits. All that is required is a little patience. By carefully applying this instruction you will experience no difficulty. If you cannot secure, from your hardware dealer, the fender, andirons and tongs, you can, with a little ingenuity, make these out of wood and then paint them black, or perhaps you have the requisite accessories already on hand.

430. Select a north window which will give you the most even illumination and then, near the window, place the table, or construct a small platform of suitable height; cover it with a carpet or hearth rug and set the fender in position. Draw down the curtain on the window to within two feet of the window-sill. Place your subject in position, trying to have as natural a pose as possible. A couple of children are excellent subjects for firelight studies. Now place the camera in position (which should be almost on a line with the subject, and parallel with the wall, so as to obtain an end view of the fender) and, after having secured a sharp focus, you may then find it advisable to decrease the size of the opening in the window, remembering that only a sufficient amount of light should be admitted to give the exact effect of the ordinary fireplace. If the curtain is too

high, you will have too much general illumination in the room, which will result in too flat an effect. It is desirable, in fact necessary, to have a contrasty negative. While fire-light is generally quite strong, yet it only illuminates those features of the individual which are directly facing it. It is not necessary to soften or diffuse the light from the window in any way, nor should you use a reflector. Aim to secure an effect similar to that shown in Illustration No. 26.

431. Be very careful not to over-expose your plate, yet give a sufficient amount of exposure to fully time the high-lights, then develop the negative until these high-lights have become normally dense. When the negative is fixed the shadows should be clear glass, the high-lights being strong enough to hold up well in the printing.

432. In addition to filing proofs of the negative thus secured, it also would be interesting to have a print from a negative showing the general arrangement of your room. On the backs of the proofs should be placed full data regarding the manner in which you proceeded to secure the results and these prints should then be filed in your regular proof file.

CHAPTER XXVI.

Groups.

433. Very large groups cannot be made in the home unless a large room with sufficient illumination can be had; therefore, it may be necessary for those who are compelled to work in small quarters to arrange their large groups on the porch or somewhere in the shade of the home.

434. Usually from two to four, with sometimes as many as six figures, can be successfully lighted in an ordinary room; more than this number should not be attempted unless an extraordinary large room can be had with good illumination. Those who have the proper facilities, or the resident photographer who is working by a perpendicular light—which is generally an ordinary, large window built in the residence, and from which sufficient illumination can be obtained to make any style work, even to good sized groups—will experience no difficulty in producing satisfactory results.

435. In Illustration No. 27 we have a group of two children in which you will observe that the pyramid arrangement has been adhered to. In this group, we recognize in the older child the principal, the smaller one smiling and content in the arms of her elder sister. Observe the congeniality in pose and expression—both having a perfectly natural attitude. (See Page 169.)

436. In Illustration No. 28 we have a group of three children. Here the pyramidal arrangement is more in evidence. The principal member of the group is on the end, the other members close around her. Note that they are not arranged on parallel lines and that all hands and arms are differently posed, breaking up all lines and avoiding repetition of arrangement. (See Page 169.)

437. In Illustration No. 29 we have a very pretty pose of a mother and two daughters. Observe the arrangement of the drapery and the preference in position given to the younger daughter, the other occupying a rear position. The group tells its own story.

438. In Illustration No. 30 we show a family group. This is well balanced, well arranged and congeniality throughout is very apparent. A very important feature of this group is the distribution of color. In the previous illustrations we have pictured only white drapery, while in this instance there are mixed colors—some dark and some light. Many make the mistake of distributing the dark and light evenly throughout the group, first placing a subject gowned in dark drapery, then a light one, then another dark one, and so on. This is an error. You must avoid a spotted group by arranging the majority of one color in one group by themselves. This constitutes your principal, around which the other should be arranged in separate groups.

439. However, should your principal group be gowned in dark drapery and you still have a number dressed in dark while all the rest are dressed in white, then place the remaining dark-gowned members at one end, forming a small group at that end. The result will be that when viewing the picture, the eye is attracted, first by the principal group in dark, next by the members in white, and finally by the single figure or small group on the end. Such a group will never lack interest, but, on the contrary, will grow more fascinating each time you look at it. No matter how natural all the members may appear and how gracefully each individual may be posed, yet if the dark and light gowns are scattered throughout the group, it will look spotted and ill-pleasing to the eye. Your first consideration must, therefore, be concentration of color. Collect your group and divide it into two parts, separating the light-gowned members from the dark. Construct your principal group from the smallest number of one color.

440. In Illustration No. 30 you will note that there are



“TWO AGAINST ONE”

STUDY No. 14—See Page 403

JOHN S. NEARY

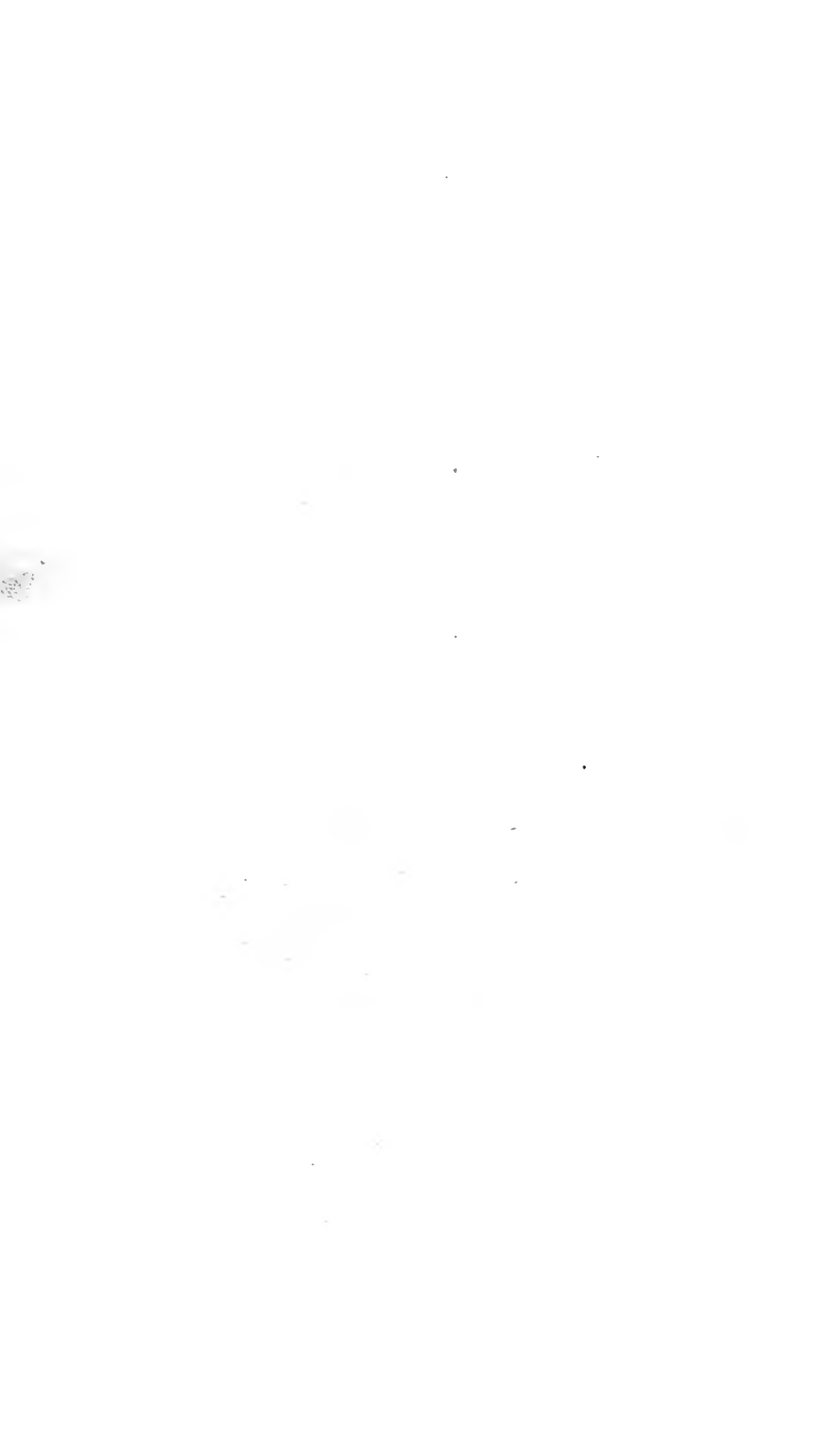



Illustration No. 29—See Paragraph No. 437
Group—Mother and Children



Illustration No. 30—See Paragraph No. 438
Family Group

four members dressed in dark and one in mixed colors. The least number in one decided color is always more conspicuous and, therefore, must not be scattered, but concentrated in one locality as much as possible. In the large group they should not occupy the extreme ends, neither should they hold a central position. A little to one side is best, usually the left side is selected. The ends of the group should always be made up of persons gowned in the same color—either dark or light—both ends must balance. Referring again to this illustration, observe we have formed one end of our group by arranging first the mother, in a dark dress, then the two daughters, who are gowned in white. The three complete the first and principal section of the group. Next, the father was seated comfortably at the further end, with one son sitting on the arm of his chair. We placed another son in the center, and finally, between the two groups, arranged the younger boy in the foreground, connecting and completing the group.

441. Upon first glance at this picture, the eye is attracted to the brightest spots, which in this case are the two children dressed in white. Almost at the same moment the sweet expression on the mother's face is observed. The little one resting on mama's knee and the standing figure leaning over the chair help to cement this group together and make it complete in itself. Gradually the eyes drift across the picture until you reach the face of the father with the three sons around him, forming the additional group, the principal subject of which is the father. By a glance over the entire group you are impressed with pleasing countenances denoting congeniality.

442. By reference to the lines drawn across different portions of this group, you will note how we have divided it into sections; each section remains a very pretty group by itself, yet each individual group has a principal of its own, less conspicuous, however, than the groups collectively.

443. Larger groups are constructed along these same lines, and you must bear in mind that your individuality

will count to a great extent after you have mastered these elementary principles of arranging small groups.

444. **Good Drawing.**—Good drawing is as essential in a group as in a single portrait. We have found that the pyramidal arrangement is very simple to handle and will produce the best drawing with the least effort. Too great an emphasis cannot be laid upon the excellent opportunity, afforded in groups, for individual posing of a number of subjects, each one in sympathy with the other members, and each in an easy and natural position. If, after having arranged the group, some of the subjects seem to be awkwardly placed and do not assume an easy position, change them from the standing to a sitting position, or *vice versa*, and you will generally find one position that will be the more natural.

445. **Lighting.**—When dealing with a large group, all the available light in the room should be used, for the light necessarily weakens at any considerable distance from the window, and while the end of the group nearest the source of the light will be strongly illuminated the furthest end will be insufficiently so. A flat light should be avoided, but, otherwise, there is plenty of latitude for securing a reasonable amount of light on the face. This gives a new factor to be considered when arranging figures to their best advantage, for taking two end figures which are oppositely lighted, there are many intermediate positions between them that would give intermediate forms of light which will be found to suit a certain figure better than others. This is but one of the many points to be thought of when arranging a group, and the result must always be more or less a compromise.

446. Unless you have a high window and one that is quite wide, you will have difficulty in securing proper light on a large group, such as this. However, for small groups of from two to four members, the ordinary window will answer, and where the light from two windows can be employed, you will experience less difficulty in obtaining the required illumination.

447. To receive the full benefit of all the light coming from your window, place your subject a trifle back from the end of the window, and partly facing the light. You will thereby illuminate the members on the far or shadow end of the group as evenly as those near to the light. With very large groups, however, it is best, as stated before, to arrange your group out-of-doors in the shade of some building, unless you can use a room with an extra large window.

448. Never place a group in the shade of a tree, unless the foliage behind the group is very dense, for if the sun strikes through the foliage it will cause light blotches and spots, which are very displeasing. A wide porch or veranda may be used to good advantage.

449. **Exposure.**—Group pictures will require more exposure than the single portrait, for there is a larger space with more shadows to cover, and therefore you can calculate on at least double the exposure given single figures.

450. **Backgrounds.**—Large portieres or curtains—provided that they are not too dark—make good backgrounds for group pictures. If extremely dark they prolong the exposure. Usually, sitting positions are the easiest arranged; and then, too, when your subjects are seated lounging, or even sitting erect, they hold their position with more ease, and there is less liability of their moving during the exposure.

451. **Diffusing the Light.**—For groups you will require less diffusion of the light entering the window than you will for single portraits, for you naturally work farther from the source of light. However, some diffusion is necessary in order to spread the light over the entire space.

452. **Reflecting Screen.**—Frequent use of the reflecting screen should be made, and it should be so arranged, and placed at such an angle, as to reflect the light from the front into the faces of the group, thus giving more roundness.

453. **Practice Work.**—For practice work we would recommend that not more than two or three figures be ar-

ranged in one group and where two windows can be employed you should make use of them both and arrange your subjects so they, partially at least, face the source of light.

454. Having carefully studied the instruction regarding the arrangement of figures, controlling the light, use of the reflecting screen, etc., proceed to arrange your group. For your first experiments you should not select subjects gowned in contrasting colors. The more uniform the colors the easier it will be for you to control the light. Place your principal figure first, in a position where it will receive fairly good light, and arrange it about as you would if you were making a Plain Portrait Lighting. Then introduce the second figure, arranging it in a like manner but posed differently. If a third figure is to be admitted be sure to have the figures placed so that the heads will not be on a straight line. The farthest subjects from the window should be arranged more facing the window, thus giving all an equal illumination.

455. See that the light falls evenly and that all members are uniformly illuminated. If the light seems too harsh and strong, make use of the diffusing screen in the window. If the windows have lace curtains, draw them slightly before the window, sufficiently to diffuse the harsh light and distribute the illumination equally over the entire group. You will find it necessary to make free use of the reflecting screen. Place it at such an angle that it will reflect the light into the front of the face of the subject. The camera should be placed so as to secure a proper lighting on the group. This will give you a position near the window. Focus with an open lens and only stop down enough to produce a reasonably sharp image throughout. Before making the exposure, see that each member of the group has an easy, comfortable, as well as natural, position and *then* make your exposure. You can judge the amount of exposure required by the appearance of the image on the ground-glass. You will find that it will usually require double the exposure necessary for single portraits and some-

times more, all depending on the source of illumination employed.

456. Do not make less than two negatives, giving one almost double the exposure of the other, and on developing the two plates you will have a good key to the proper exposure of groups made under like conditions. Make proof prints from both, noting all data pertaining to their production on the back, being particular to note the amount of the exposure given, the time of day, stop used, etc., also the conditions of the source of light employed, whether diffused or open. File these proofs in your proof file for future reference.

CHAPTER XXVII.

Difficulties—Groups.

457. **Arrangement of Groups.**—Before attempting to pose figures in the form of groups, a very careful study should be made of the lesson, as well as of the group illustrations in this volume and Volume VII. There are many ways of arranging subjects to form pleasing effects, the best and easiest to arrange being those in pyramidal forms. Always make your subjects feel perfectly at home; otherwise, stiffness and set positions will invariably result. The height of the subjects must be the first consideration, while the second is the adaptability of the features of the various subjects for various forms of lighting. Persons with full faces photograph better in Rembrandt and Shadow Lighting effects. Therefore, they should be placed near the light, but facing away from it. Many persons photograph best in Plain Lighting, and such should face the source of illumination. Tall persons should usually be seated, while short ones are more easily handled, in smaller groups, by having them stand. In large groups it is often necessary to have an extremely tall person stand at the back and a little to one side of the center of the group. Your individuality must be brought into play, and judgment used in selecting the subjects so each one will fall into the particular place that will give him the best possible advantage, both for lighting effect and for posing. Each subject in the group is of vital importance and must receive individual attention. Do not try to bunch a number of people together and expect to secure satisfactory and pleasing results—this cannot be done.

458. **Arranging Groups of Children.**—As children are naturally graceful they are very easy to handle, and readily fall into the various positions given them. Stools or chairs of different heights may be employed, yet usually a settee will be one of the most convenient accessories to use for the smaller groups. Where a large number of children are to be photographed, the addition of a chair and other accessories may be necessary. Never try to force children into the different positions. Simply direct them to take

the positions you wish to have them occupy. Under no circumstance have one head directly over the other.

459. **Arranging Groups of Adults.**—The same pyramidal idea of arrangement should be carried out in grouping adults. Where children are included in such groups, the older persons should be grouped first and the younger members arranged about them. Little ones may be arranged to fill in any gaps which may be formed in posing the adults. Under no circumstance should all figures face toward the camera. The greater the variety of individual positions the better.

460. **Arranging Groups of Two.**—The heads of the two subjects should be quite close together, for if widely separated the resulting picture will be practically square. A panel shape is far preferable. Never have one head directly above the other, and do not have both bodies facing in exactly the same direction. As a rule, the bodies should face slightly toward each other. It is permissible, also, to have one turned a trifle to one side and the other facing almost squarely front, but the person who faces front should be of slender stature. The bodies of heavy built persons should never face the camera.

461. **Arranging Large Groups.**—In arranging large groups the ideas and the principles involved in handling small groups should be carried out. In fact you should select the three most important persons and artistically group them. Then add the other figures as you see fit. It might be a good plan to arrange two or three groups of three, and then fill up the vacant spaces with the remaining subjects. It is usually advisable to carry out the pyramidal form. Do not have one head come directly above the other, and avoid having all bodies face straight toward the front. Have some turned slightly to one side, but all turned toward the central figure in the group.

462. **Preserving Congeniality.**—To preserve congeniality in a group consideration must be given to the most important subject first, and this subject properly posed and lighted, before the other figures are introduced. When the principal subject has been arranged to your liking, then surround it by the others. Place them in such a manner that they will be interested in the principal subject, and if possible give each individual something to do or to look at. In this way their expressions will be far superior to what would otherwise result if they had nothing to think about.

463. **Arranging Full Length Groups.**—The greatest difficulty in arranging full length groups is in arranging the hands and in placing the feet. Bear in mind that the nearer an object is to the camera the greater will be the distortion. For instance, the feet,

as compared to the head and body, will be very much out of proportion when the subject is seated facing the camera. Wide angle lenses (lenses of short focus) will always give this exaggerated effect; therefore you should use a lens of as great a focal length as you can secure; remembering, however, that the longer focus lens requires more room in which to work, and as the average room is none too large for posing of groups it will be necessary in many cases to use a short focus lens. If this is the case, the swing-back on the camera should be used to equalize the distance between the various parts of the group and the camera.

464. **The Hands.**—Do not show the hands any more than is absolutely necessary, as they very easily detract from the faces of the members of the group, and may ruin what would otherwise be an artistic result. At the same time you must avoid hiding the hands completely, and never have a hand appear cut in two by burying it in the drapery. When possible have the hands fall naturally out of sight. Always have the fingers gracefully curved, and avoid having the hands sticking out straight with the fingers spread.

465. **Arranging Three-Quarter Length and Bust Groups.**—The same ideas must be carried out for this class of groups as for the full length. It is permissible, however, to have the camera much nearer to the subject, thus securing a larger image; but all the lines of the bodies, the positions of the hands, etc., must be the same as for full length groups, for if attention is not paid to these points the best of results will not be secured. If the space in which you are working is very small, the members of the group may be bunched together. Have all subjects on one side of the center face in one direction, and those on the other face in the opposite direction. This will bring them closer together, but will tend to produce a set formation, which ordinarily is not at all desirable.

466. **Correct Angle of Light for all Subjects.**—If each individual subject was properly lighted as it was introduced into the group, the completed group, with but a few corrections will be all right, and you may proceed immediately to make the exposure. Hasty grouping would, however, result in lack of individual attention, and considerable time must be consumed at this point in making changes and altering the position of each person to give them proper lighting.

467. If you are not able to light each subject correctly with the source of illumination at your command, the diffusing screen and the reflector must be taken advantage of; and these, together with the proper exposure, will give you as near a perfect result on the individual subjects as is possible to obtain.

468. **Even Illumination.**—If the light is not properly controlled the subjects nearest the window will be very strongly lighted, while those on the opposite end will not receive a sufficient amount of illumination. Soften the source of light and protect those persons nearest the window from the direct rays by the use of the diffusing screen. Then swing the end of the group, furthest away from the window, around towards the window as much as possible, with due consideration to the proper placing of your camera. Throw as much reflected light as possible on this end of the group, and then by giving plenty of exposure the developed negative should show an even illumination of the whole group.

469. **Proper Lighting for Quick Exposures.**—Bear in mind that a harsh, contrasty lighting will require more exposure than a diffused light, for, in the former case, the light being very contrasty, the shadows will lack illumination. When the light is diffused the high-lights will be softened and the shadows illuminated by the general diffusion of light throughout the room.

470. **Contrasty Results.**—Contrasty effects will result if the light has not been sufficiently diffused, if the reflector has not been used and if the exposure was too short.

471. **Spotted Effects.**—When subjects of both sexes are posed in a group you will have extreme contrast of white and black in the drapery to contend with; the men usually being dressed in black, while the ladies may be in white. Never separate the various subjects so as to have the white draperies mixed in with the black. So far as possible place the subjects in white drapery together and those in black by themselves. If the background is dark it is usually advisable to have the ladies occupy a central position in the group, the men being arranged around them. If the background is very light in color the reverse of these positions should be taken. Avoid too set a formation, however. There should be more subjects in black on one side of the center than on the other, and you should strive toward a triangular form of arrangement of subjects with regard to the color of the drapery.

CHAPTER XXVIII.

General Flashlight Photography.

472. **Indoor Work with Magnesium and Flashlight Powders.**—Photography by flashlight is now within the reach of all without danger, difficulty, or much expense. Ordinary care, of course, is still necessary and it is advisable to know something about the materials with which you have to deal. There are many kinds of apparatus available, all of which are perfectly safe if *understood and handled properly*.

473. **Flashlight Powder.**—Magnesium is the principal medium used for flashlight work, either alone in the form of sheets or powder, or mixed with some chemical compound such as Potassium Chlorate, Potassium Bichlorate, Potassium Nitrate, Antimony Sulphide, Permanganate of Potash, Gun-Powder or Pyroxyline. Some of these compounds are extremely dangerous and, therefore, we will not give them any consideration, as there are many excellent flashlight compounds on the market which are perfectly safe to handle.

474. **Magnesium Flash-Sheets.**—The most simple and least dangerous of all flashlight materials are Eastman's flash-sheets, for with these sheets, all that is required is to pin one or more on to a white cardboard and stand the latter on end, or you can even hold the cardboard in the hand and by touching a match to the lower edge of the sheet it will burn rapidly and give a very bright light. Flash-sheets, however, are not instantaneous and, therefore, should only be used when photographing still-life, interiors, etc. As the volume of light from flash-sheets is not great the sheets can be used only where the amount of illumination required is small.

475. **Pure Magnesium Powder.**—Pure magnesium gives a very white light, but as it does not explode from fire or fuse, as do Luxo and other similar flash-powders, a machine must be used with a spirit-lamp attached, into the flame of which the powder is blown from a magazine chamber, where it burns with a very brilliant white light. For a magnesium flash-machine see Illustration No. 31.



Illustration No. 31
Magnesium Machine
See Paragraph No. 475

Pure magnesium powder is seldom used for portraiture, as it is not instantaneous. Its principal use is found in commercial work and the beginner should not attempt to use magnesium light until he has had some experience with flash-powders generally. One objection against the use of pure magnesium powder is that it cannot be handled as conveniently as flash-powder. It is not possible to place a heap of powder on any surface and fire it with a match, as is the case with magnesium sheets or flash-powder. When pure magnesium powder is employed, it is absolutely neces-

sary to use a regular magnesium lamp containing a rubber tube with which you blow the magnesium into the flame, when all the powder will ignite; while, if piled in a heap and an attempt made to ignite it, it will simply make a slight flicker and cake up and nothing more result.

476. A suitable magnesium lamp may be procured from any supply dealer at a slight expense, the smaller sizes selling as low as \$1.50. Most of these machines, in addition to the magnesium powder-chamber, have a small pan over an alcohol-fed wick with a blow tube directly over the center of the pan, operated by a pneumatic bulb. With a little practice a uniform flow of powder can be forced over the alcohol flame by substituting for the rubber bulb and tube a 3-ft. rubber tube with a glass mouth-piece. By blowing through this tube, you will be able to secure a uniform flow of the powder instead of a series of short puffs, and thus attain a more even distribution over the flame. Be very careful, however, not to draw the air from the pan into the mouth. This can be easily avoided by taking a good long breath of air before applying the lips to the tube. It is possible to regulate the force of the air, without the mouth-piece, by using a rubber tube to which is attached an ordinary pneumatic bulb and a large storage bulb. The storage bulb is fed from the small bulb until full and uniform pressure is then given to the storage bulb while the powder is blown evenly into the flame of the lamp.

477. If the blow is too violent, the powder will be expelled from the pan unburned; if too feeble the powder will cake in the pan before being ejected. When the powder begins to cake the most violent blow from the mouth or bulb is insufficient to force it out. Therefore, care must be exercised not to blow too violently, but with sufficient force to ignite all the powder that is blown into the flame.

478. **Flashlight Compounds.**—It is not advisable for anyone to make their own mixtures, for if the process be not thoroughly understood and proper care exercised, there is great danger of serious accident resulting. Chlorate of Potash requires cautious handling. Excellent flashlight

mixtures are on the market and obtainable from all dealers at a price fully as reasonable as you would be able to purchase the separate ingredients and mix them yourself. *Mixtures and compounds must not, under any circumstances, be employed in the lamp intended for magnesium powder. If used in such lamps as soon as the powder is ignited an explosion would immediately occur.* Specially constructed lamps are made for flashlight compounds, which are operated in one of three ways. In all instances, however, the powder is spread out over a flat surface, and not concealed in a closed chamber, as is the magnesium.

479. The first, and most popular, method employed for igniting flashlight compounds, is to employ an alcohol flame. The alcohol flame is perfectly protected from the pan containing the powder and the flame is blown into the powder by means of a blow-pipe, thus igniting it. A second method is where an iron rod is automatically heated over the alcohol flame and when it is desired to make the flash, this red hot iron is forced into the powder. There is still another method where an electric current is em-



Illustration No. 32
Eastman Spreader Flash Cartridge Pistol
See Paragraph No. 480

ployed, a fine piece of platinum wire being inserted underneath the powder between two binding posts. When the switch is set and the circuit completed, the electric current will heat the platinum wire red hot, thus setting off the powder.

480. A very simple flash-pistol is manufactured by the Eastman Kodak Company and sells for 50 cents. With this pistol any work on a small scale can be accomplished with little or no danger to the user. See Illustration No. 32. For larger work or purposes requiring more powder than

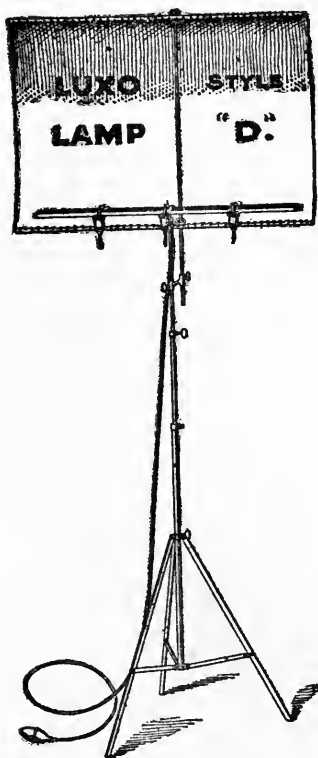

Illustration No. 33
See Paragraph No. 480

the small cartridges contain, the style "D" Luxo lamp will be found very serviceable. See Illustration No. 33. If it is not possible to purchase a lamp in which to use the flashlight compound, an apparatus may be very easily constructed at home at little cost. A stand of some kind upon which to

place the flashlight is essential, as it will be necessary to vary the height of the flash. A tin dust pan or a large sheet of tin or zinc may be placed on top of a box, small step-ladder, or some such support, which may be regulated at various heights, and the powder spread out on this pan or sheet of metal.

481. **Preparing the Fuse.**—To prepare the fuse, where a flat pan is used, place a little cotton batting or absorbent cotton on the pan (a pan with a handle preferred), pour sufficient powder on the cotton, well scattered, and allow a small piece of the cotton to hang over the edge of the pan, say four inches. Use this as a fuse for igniting and setting off the flashlight. When you are all ready place the pan on a table, or step-ladder, and light the end of the cotton with a match or lighted candle. Do not look into the flash, but as soon as you light the cotton turn your face away from the powder, as the light is very dazzling and not good for the eyes.

482. **Placing the Flashlight.**—The proper location of your light depends a great deal on what you are photographing. If you are making a picture of an interior of a room, you should place the flash one foot higher than the top of the camera and only a trifle to the side of it. This will save heavy shadows against the wall or background which would result if the flashlight were placed more to one side. If you are making a group picture you should turn the faces a trifle away from the light and where a muslin screen can be used between the flash and the group, it will be better to locate the flash more to the side. (See the following chapter—Flashlight Portraiture.) For general interior work it is best to place the lamp close to the camera.

483. **Shielding the Lens. Caution.**—When arranging the flash-machine, see that it is placed in such a position as not to reflect into the lens, as the plate would be instantly fogged and your negative result in a failure. Where you find it necessary, which may be the case when working in close quarters, to place the flash in front of the line of the lens, carefully shield the flash from the lens by means of

a screen or cardboard placed between the lens and the flash. Another caution is, *never*, on any account, use *flashlight compounds* in a *magnesium lamp or cup* intended for pure magnesium powder, for, in doing so, you are sure to have an explosion.

484. **Practice Work.**—For your first experience at flashlight photography, you should not attempt to work with difficult subjects, such as portrait or group subjects. Try an interior or a still-life object—a vase, a small piece of carving or statuary, etc. In so doing you will become acquainted with the manipulation of the powder and be better able to judge more accurately how much powder is required and how to control the light on the object. With the object about four feet from the lens and your flashlight placed to one side of the camera, you will require, if the flash-sheets are used, about eight to ten inches of the flash-sheet, or about twenty grains of flash powder. With this amount of illumination and with the lens stopped to f. 8, using ordinary dry plates or film, you should be able to make a fully timed exposure.

485. **Developing.**—The plate should be developed with a quick-acting developer, such as Pyro, Metol, Rodinal, etc. The Universal Pyro formula given in Vol. II will give good results. Strive for delicacy of detail; avoid contrast and density. It is advisable always to cover the tray during development. Make proof prints of all exposures. Note on the backs of these proofs all data connected with the producing of the results, whether by flash-sheets or flash-powder, giving number of the negative, subject, date, etc. Also give the distance (in feet) of subject from lens and background; distance of the flash to right, left, front or back, or above subject and amount of flash-powder used; kind of reflector, aperture of lens, plate used, etc. Each and every one of these items are useful for your future guidance.

CHAPTER XXIX.

Flashlight Portraiture.

486. **Introduction.**—It often will be found inconvenient and practically impossible to secure a portrait lighting in the home on account of the location or size of the windows. It may be desirable to make portrait lightings at night and, of course, the daylight could not then be employed. An excellent substitute for daylight for the At-home portrait worker, is to be found in the flash-light, and the modern compounds on the market at the present time will be found available for this purpose, as they are practically instantaneous and there is very little likelihood of any movement of the subject.

487. As a rule, the first attempts to make photographs by flashlight result, in a vast majority of cases at least, either in partial or complete failures, causing many to become discouraged and to give up making further attempts at this feature of photography. As a rule the difficulty is always due to lack of knowledge of the peculiarities of flashlight work. If ordinary precautions be taken and the instruction contained in these lessons carefully followed, results equal to daylight will be secured. If much portrait work is to be done by flashlight, it would be very advisable to employ a simple and practical flash-lamp—one that is perfectly reliable and safe, easily set up and operated, and occupies little space. The flash-powder should be one that is safe, instantaneous, yet not highly explosive, producing the greatest amount of actinic light, of uniform mixture, leaving no undesirable odor and giving off the least amount of smoke.

488. Flashlight for portraiture will produce exactly as

good negatives as daylight, for while the light is concentrated yet it is under perfect control for shading and for softened effects. One advantage the flashlight has over daylight, especially in At-home Portraiture, lies in the exposure, which is instantaneous, the amount of exposure being measured only by the amount of powder used. These conditions being always the same, you can invariably give a



Illustration No. 34
Nichols' Professional Flash-lamp
See Paragraph No. 489

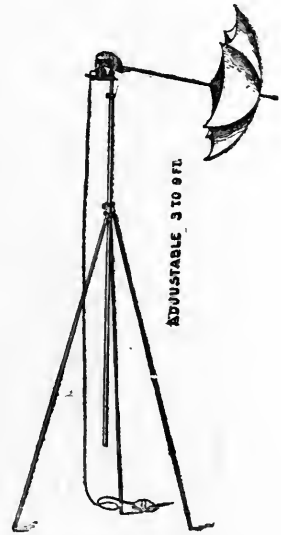

Illustration No. 35
Nichols' Junior Flash-Lamp
See Paragraph No. 489

uniform exposure; accuracy in timing the negative is therefore a very easy matter.

489. Of course it is not necessary to go to the expense of purchasing a flash-lamp. You can easily construct a simple piece of apparatus which will answer the purpose, but it is, naturally, not so convenient. One of the most successful and practical lamps and one which has been on the market long enough to have been thoroughly tested, is the Nichols' Portrait Flash-Lamp. This lamp, however, is intended more for professional work. (See

Illustration No. 34.) A smaller size, known as the Nichols' Junior Flash-Lamp, is intended particularly for home portraiture and is a very convenient lamp to operate and is also perfectly safe. (See Illustration No. 35.)

490. The powder in this lamp is ignited by means of a small quantity of alcohol which is forced through a flame onto the powder. The alcohol, being ignited in passing through the flame, produces a large spread of flame which is forced down on to the powder by the pressure of the air following. There are two cones fastened to the flash-pan. One-third of the whole charge of powder is to be used in front of and between these two cones, not spreading it out, but placing it in the shape of a V. The remaining two-thirds of the charge should be placed in the two cones

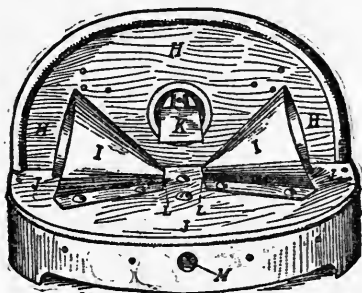

Illustration No. 36
Sectional Front View of Nichols' Flash-lamp
See Paragraph No. 491

so that the holes in the apexes are filled and the powder unites with that placed between them. There will then be three separate lots of powder all connected at the center.

491. **Explanation of Front View—Illustration No. 36.**—H H H—Safety back completely separating the alcohol flame from the flash-powder; K—Cap over the end of the blast-tube, employed to spread the flame of burning alcohol, throwing it in such a manner that flash-pan, J J J, is covered with a mass of flame with the result that the powder is sure to ignite instantly; I I—Two cones into each of which one-third of the whole charge of powder is placed,

the remaining one-third placed in front of cones and the piles uniting at the ends, L L. The powder in the cones, when ignited, forces the flame out to either side, giving a very broad flash flame; M is a hole into which the folding screen is fastened.

492. **Explanation of Rear View—Illustration No. 37.**
 ~H H H—Safety back; E—Alcohol lamp burner; B—Brass

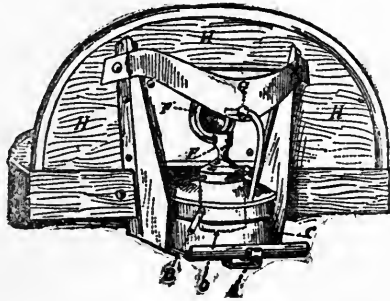

Illustration No. 37
 Sectional Rear View of Nichols' Flash-lamp
 See Paragraph No. 492

tube, to which the rubber tube running to bulb is attached; A—Spring holding alcohol reservoir, C, in place; G—Brass tube through which a small quantity of alcohol, which is automatically trapped, is forced by a pressure of the bulb through blast tube F onto the flash-pan. This small quantity of alcohol on passing the flame from the burner E is ignited, forming a great mass of flame which insures instant and noiseless ignition of the powder placed on the flash-pan.

493. A regular standard may be purchased with the lamp, which is convenient and light, handy to carry and has an elevation of over ten feet, ample for all practical purposes.

494. **Diffusing Screen.**—As the light from the flash-lamp is very concentrated, there is a strong tendency toward harshness. In portrait work, therefore, by the use of a cloth screen between the lamp and the subject, or even a group, any amount of diffusion may be obtained. For this

screen, a light-weight, bleached muslin or lawn should be used, containing little or no starch and it should be not less than three feet square. Common cheese-cloth will be too thin unless very sharp lightings are wanted, while too heavy cloth requires a large charge of powder, and gives too much diffusion. Accompanying the Nichols' Flash-Lamp is a folding, white muslin-covered umbrella which will be found very suitable for all purposes. For At-home portrait work, a frame built of light wooden strips (window stops), covered with thin muslin will be found very cheap and convenient. This screen should not be less than five feet high and four wide. The bottom of the screen should be four feet from the floor and it should be set at an angle of 45 degrees from the perpendicular.

495. In a screen of this size the sitter is separated from the flash, which will be found very advantageous at times when working in one room. It would be convenient to have the base or support of the screen provided with casters so that it may be moved around as easily as the lightest background. Instead of moving the sitter to produce the desired effect in lighting, you leave the sitter undisturbed and adjust the lamp and screen instead.

496. The screen should be two feet from the lamp and at such an angle that the rays of light from the lamp to the sitter pass through it as nearly perpendicular as possible.

497. **Reflectors.**—Reflectors to illuminate the shadow sides of the subject should be exactly the same as for ordinary daylight work. As a rule, the reflector should be placed from three to five feet from the sitter on the side opposite the lamp. Do not place the reflector directly at the side of the sitter, at an angle which will reflect the light on the front and side of the subject as well. A safe rule to work by is to place the reflector at as near as possible the same angle from the sitter as that at which the lamp is placed. The light will then be reflected onto the shadow side of the sitter's face at the same angle that the direct source of light from the lamp falls on the light side and will not have

the effect of flattening the shadow side of the face by producing a high-light where there should be a shadow.

498. For producing Rembrandt effects, the reflector should be somewhat nearer the sitter than in making Plain Lightings. If you do not use a diffusing screen, the re-

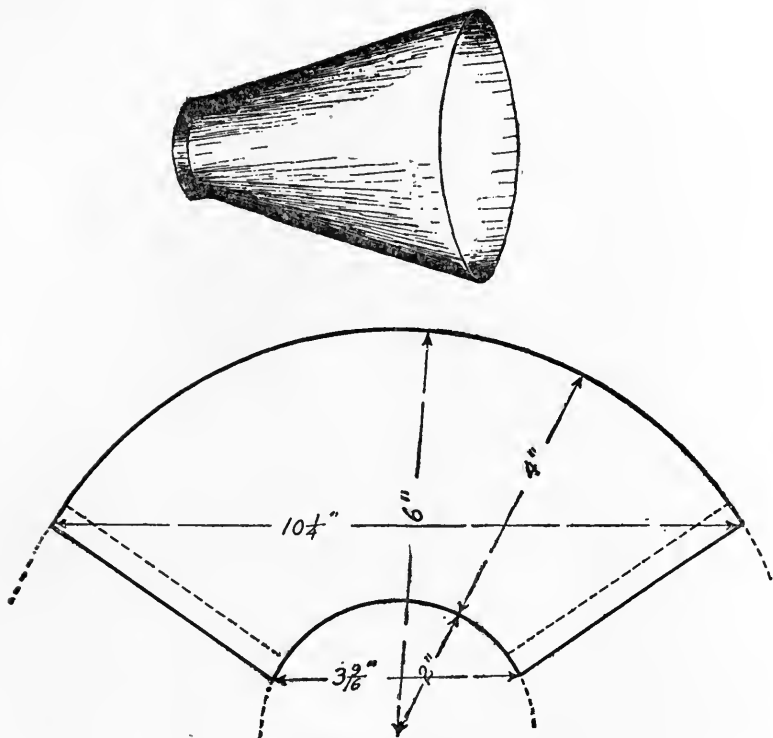

Illustration No. 38
Lens Hood
See Paragraph No. 502

flector should be considerably nearer than when the diffusing screen is employed.

499. In photographing a person wearing glasses, use no reflector unless a Rembrandt Lighting is made. The use of a reflector in making a Plain Lighting is quite likely to produce a bad reflection in the glasses.

500. **Shading the Lens.**—In extreme shadow lightings, or with full length figure positions, when a larger lens is used than is necessary to cut the size negative being made, the camera is often located at such a distance from the subject that the flash is closer to the subject than to the camera. Then, even though the flash be out of direct range of the lens, it will cause a diffused or false light to be reflected in the lens, producing an even fog over the plate. In such cases it is necessary to shield or shade the lens, which can be effected, when making the exposure, by holding a large piece of cardboard in the proper position between the lens and flash, or by placing a screen between the two. No matter what device you employ in shading the lens always be careful that it does not come within the range of view. This adjusting is best done when focusing.

501. **Lens Hood.**—When there is any danger of strong light striking the curved surface of the lens, and thus causing cross reflections and light fog on the plate, one should use a lens hood to cut out all side reflections. Especially in flashlight photography is it essential that a lens hood be employed. In fact, one should be used in all cases where the lamp is placed even with or in front of the lens, for the volume of the flash extends some little distance in front of the lamp, and although one might think that the light will not fog the plate, the chances are that it may; so precaution, when using flashlight, is important.

502. A hood may be easily made of heavy black paper or light weight cardboard, by cutting the sheet the shape shown in Illustration No. 38. The dimensions given for this hood are correct for the average hand camera lens of 1 to $1\frac{3}{8}$ inches in diameter. Before pasting the two ends together the cone should be placed around the end of the lens tube, so that it will be tight and fit perfectly. The two ends should then be pasted or pinned together.

503. In cutting the pattern for this hood the outside is the arc of a circle, the radius of which is six inches, while the inside edge is the arc of a circle having a two inch radius. This will give a cone practically four inches long.

The distance between the two extreme corners is $10\frac{1}{4}$ inches, while that between the two inside corners is $3\frac{9}{16}$ inches.

504. After the two edges of this cone have been fastened together, a band one-half to one inch wide should be pasted around the small end of the cone, so as to give a sup-

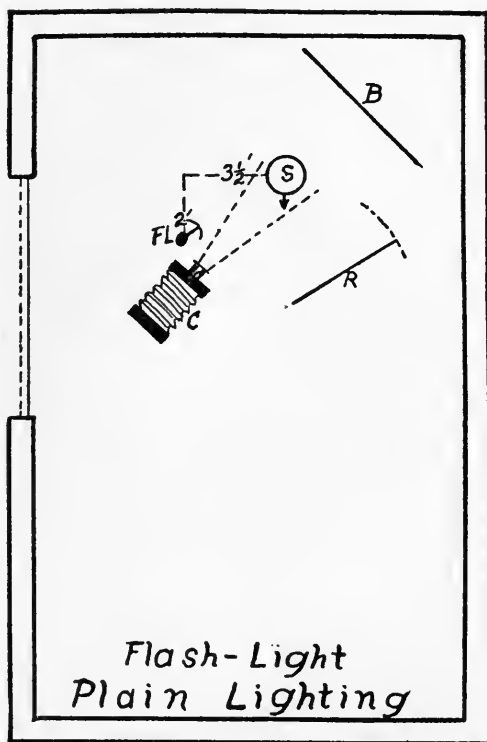

Illustration No. 39
See Paragraph No. 508

port, and have the cone fit snugly over the lens mount. The point where this band and the end join should be fastened by pasting a strip of black cloth around the inside and outside. Black paper or cardboard must, of course, be em-

ployed, in order that there will be no reflection of any kind, and care must be taken that the hood does not cut into the angle of view.

505. To make a larger cone the dimensions should all be proportionately increased. For instance, doubling all the

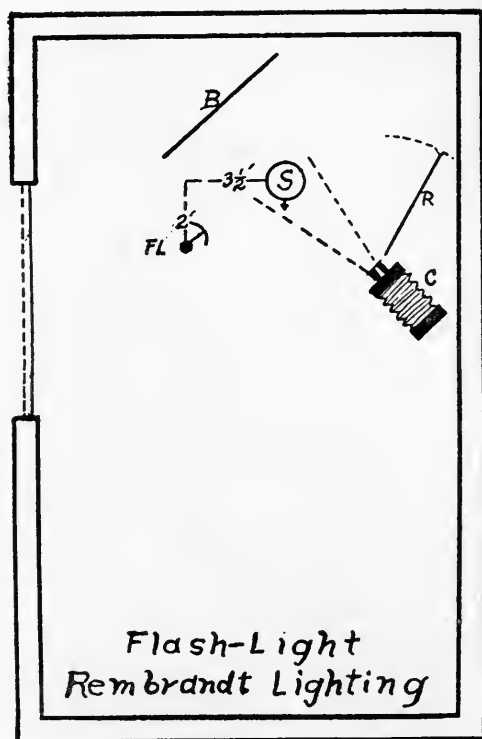

Illustration No. 41
See Paragraph No. 509

measurements will give a cone that would fit on a lens of approximately two inches in diameter.

506. By using precaution in shading the lens in flash-light work, you will never be troubled with fogged negatives.

507. **Position of the Light.**—To properly illuminate a face, the light should all come from one source and should fall at an angle of about 45 degrees.

508. **Plain Portrait Lighting.**—To secure a Plain Portrait Lighting the lamp should be placed $2\frac{1}{2}$ feet above the sitter's head, 2 feet in front and $3\frac{1}{2}$ feet to the left of the subject. Have the face of the sitter turned so that when you stand directly between the lamp and the sitter, the tip of the nose just breaks the outline of the shadowed cheek. (See diagram No. 39 of floor plan.) The amount of powder required will depend upon the surroundings and also the size of plate used. Usually from $\frac{1}{16}$ to $\frac{1}{8}$ of an oz. will be sufficient if a white reflector be placed about four feet from the sitter. In making this lighting it will seldom be necessary to shade the lens. In Illustration No. 40 is shown an excellent example of the results obtained with the Nichols' Flashlamp.

509. **Rembrandt Lighting.**—For Rembrandt Lighting the lamp is placed in almost the same position as for Plain Lighting, but the camera is moved so as to secure a view of the opposite side of the face (shadow side). See diagram No. 41. A white reflector should be placed about five feet from the subject and directly opposite the lamp. From $\frac{1}{8}$ to $\frac{1}{4}$ oz. of flash-powder will be necessary to give the proper amount of illumination and the lens should be shaded as previously directed.

510. **Groups.**—In making large groups, the lamp may be used without a screen, but it is always best to use the screen as softer results will be produced. If the ceilings are sufficiently high the lamp should be elevated enough so that the light falls at the proper angle on the subjects in the center of the group. The lamp must always be placed near enough, in front of the group, so the shadow cast from any one face is thrown back of it instead of on the person sitting next. Avoid grouping close to the wall, as shadows cast on it are anything but pleasing. The group should be at least four feet from the wall or background.

511. **Focusing.**—Always focus with the lens wide open.



Illustration No. 40
Child Portrait Made with Nichols' Flash Lamp
See Paragraph No. 508



“GOOD MORNING”

Usually in the ordinary home there is sufficient illumination from gas or electric-light to light the subject so that you can obtain a focus. If the general illumination in the room is insufficient to light the subject, have an assistant hold a lighted lamp or candle close to the face of the subject; you can then focus more accurately. If a group is being made, focus on the central member and the rest will very likely be sufficiently sharp.

512. **Stops.**—Stop down only just enough to give sufficient sharpness. In portraiture use the lens wide open. If a group picture is being made, after having focused on the center member, it is advisable to use a one size smaller stop than what is required for average sharpness. This will allow for any getting out of line, etc., on the part of any individual member of the group.

513. **Amount of Powder to Use.**—The amount of powder required for illuminating groups depends upon varying conditions, much the same as timing in daylight. When a muslin screen is used a trifle more powder is required than when an exposure is made without it. The speed of the lens, the size of the stop, the distance of the lamp to the subjects being photographed, the size of the room and the color of the wall paper and ceiling are all important factors. In rooms finished in dark colors, there is little or no reflected light and therefore, at least one-third more powder will be required, otherwise negatives made under such conditions will have an undertimed appearance.

514. Never stop the lens down more than is necessary to cut everything fairly sharp. In portraiture use it wide open.

515. Operate the lamp as near as possible to the object being photographed.

516. For a group in an ordinary sized room with a rapid rectilinear lens and stop f. 11, or U. S. 8, unless the walls are very dark, $\frac{1}{4}$ oz. of powder will be sufficient, using the lamp without the diffusing screen. Where the screen is employed $\frac{1}{4}$ more powder will be required. Always use a good flash-powder, one that is quick and uni-

form. The Nichols' Portrait flash-powder, Luxo and Eastman's powders are recognized as good reliable ones and are safe to use.

517. **The Exposure.**—In working at night it will not be necessary to employ the shutter, but in the daytime in a well lighted room, the shutter and flash must be operated simultaneously. This is accomplished by either running a rubber tube from each end of a double-end rubber bulb—one to the shutter and the other to the lamp—or by using a hard-rubber Y, such as may be secured from photograph dealers. If this is not obtainable you can have the tin-smith make a Y out of brass or copper tubing. In using this Y, connect a short piece of rubber tubing with the bulb on the end of the lower prong of the Y. To each of the upper prongs, attach a long rubber tube, connecting one with the shutter and the other with the lamp. Should there be a difference in the length of the tubing, give the shutter the benefit of the shorter one.

518. **Shutter to Use.**—Any plain pneumatic shutter that works easily will be found satisfactory, but any of the tension shutters operating with a spring and pneumatic or trigger release, will not answer. Therefore, if you are using an ordinary hand camera and desire to work in daylight, when ready to make the exposure the direct source of light should be curtained down and the exposure made with the bulb operating the shutter in one hand and one for the flash-lamp in the other. Press the shutter bulb first, followed by the flash bulb next, then release the shutter bulb—closing the shutter. By practicing this a little no difficulty will be experienced in making the proper exposure. Care must be taken, however, that the daylight is not given any great opportunity to affect the sensitive plate, for there will be danger of movement of the subject.

519. Before proceeding to arrange the subject and place the camera in position, spread the proper amount of powder on the flash-pan of the lamp. When everything has been adjusted and the subject properly lighted and posed, the shutter closed, plate-holder in place and slide

pulled, place the lamp where you want it, light it and step back to the side of the camera so that you may see the picture from the same point as the lens sees it. If using but one bulb you should hold it behind you out of sight. See that the positions are what you want and just before exposure, designate the place upon which you wish the eyes to rest. Do not stop talking but continue some pleasant conversation which will assist in obtaining a more pleasing expression. When the position and expression are what you desire, and if you cannot connect the flash and shutter with the same bulb, squeeze the bulb of the camera first and follow instantly by squeezing the bulb of the flash. Then quickly release the camera bulb as soon as the flash is made, in order that the shutter may be closed at once.

520. **Smoke.**—All flash-powders produce some smoke and in making more than one flash the greatest care should be taken to see that the room is cleared of the smoke before making the second exposure, otherwise under-timed negatives will result. Always open the windows at the top as the smoke rises to the ceiling and will soon work its way out.

521. **Development.**—In developing negatives made in accordance with the above instruction, there will be practically no difference between the development of the daylight and the flashlight exposures. Full instructions regarding the development is given in Vol. II. There is one caution which may be given, however: As there is a tendency toward under-exposure in flashlight work, it is advisable to start development with a diluted solution, carrying the negative in this solution until you have ascertained whether or not the negative was correctly exposed. The contrasty lighting produced when working without a diffusing screen, will make it particularly necessary to use a diluted developer, which will soften the contrast.

CHAPTER XXX.

Groups and Interiors by Flashlight.

522. **Groups by Flashlight.**—The flashlight will be found far better sometimes for making pictures of groups in the home than daylight, as it is very seldom possible to secure a sufficient amount of illumination when employing the light from an ordinary window. By means of the flashlight this difficulty is entirely overcome, for the volume of light may be made as strong as desired and it can also be placed in any position with reference to the subject.

523. The groups should be arranged in precisely the same manner as has been described in Chapter No. XXVI. The flash-lamp should be placed on one side of the camera but quite near to it, leaving the lamp as high as possible, taking care, however, that it is not closer than two feet to the ceiling.

524. If using a Nichols' lamp and you have the diffusing umbrella, turn the latter so it will come between the light and the members of the group nearest to the light, thus allowing the light to proceed undiffused to those members of the group furthest from it. If the umbrella is not employed and if you have a diffusing screen, it may be placed in the same position as the umbrella, for by diffusing the light falling on the persons nearest to it you obtain an even and uniform illumination over the entire group. The lamp being placed to one side of the camera will cause a slight shadow on one side of the faces and thus give a Portrait Lighting to each individual.

525. In all flashlight work the lamp should be loaded with the powder before focusing but the alcohol flame should not be lit until everything is ready for the exposure.

Care must be taken when elevating the light, not to jar it nor to have a draft through the room, as there might be danger of the flame being blown on to the powder. Although this danger is a very remote one, yet it is always advisable to be cautious in handling all flashlight mixtures. Too much care and precaution cannot be taken at all times to avoid accident.

526. **Caution.**—Always lower a window or open a door of the room in which you are working before making an exposure. This will supply a vent for the concussion, which will be quite apparent where much powder is used.

527. **General Flashlight Interior Photography.**—Artificial light forms a very convenient method of photographing many interiors, for there are times when daylight cannot be employed on account of the poor location of the windows with reference to the important pieces of furniture or other items in the rooms.

528. All the principles referred to in Chapter No. I, General Interior Photography, hold good in making flashlights of interiors, the only difference being in the illuminant. The camera, after having been placed in position, may be focused by having someone hold a lighted candle in various portions of the room—if there is not sufficient natural light to focus by.

529. The articles included in the angle of view should be the most important ones in the room and blank spaces should be avoided as well as any effort at over-crowding any portions of the picture. If windows are included, the opaque curtains should be raised to the middle sash and everything about the room placed in exactly the same order as it would appear by daylight.

530. **Kind of Flash Material.**—Pure magnesium ribbon is a very convenient and perfectly safe form of illuminant to employ for small views of still-life subjects, and after one becomes accustomed to its use, it will be preferred to any other method of lighting. It burns slowly as compared to the other illuminants and it is possible to move it while it is burning so as to soften or accentuate various lights.

From the fact that it does not give an instantaneous flash it is not suitable for portraiture or where figures are in the view. Short or long pieces of the ribbon can be burned in different places so as to secure a perfectly correct illumination throughout the entire room. Great care must be exercised, however, that no strong light be placed in front of the lens and that the light from the burning ribbon be not included in the angle of view. It may, however, be ignited in the rear portion of the room, provided there is something between the light and the camera. For instance, if there is a piano at one side of the room, you could stand at the end of the piano and hold the ribbon so that the rays from it would not reach the lens. In this way you will illuminate some shadows at the rear of the room which could not be reached by the light when it was burning in a position near the camera.

531. For the average interior with medium colored walls and dark furniture, about 20 inches of ribbon will be required. Twelve to 15 inches should be burned on one side of the camera and five inches on the other. This will produce a sufficient amount of contrast; the secondary light illuminating the shadows enough to do away with any harshness or lack of detail.

532. When the walls of the room are very dark and everything in the room is exceptionally dark, it might require more ribbon burned as a secondary illumination, for the shadows in this case will be exceedingly deep and will require a considerable amount of light in order to obtain the desired amount of detail. Under no circumstances should the secondary light, however, be more than one-half as strong as the main light.

533. When it is deemed advisable to burn either magnesium ribbon or magnesium powder near the rear of the room in order to illuminate shadows, it will not require as much ribbon or powder in the main and secondary positions. However, if the room is exceptionally long, the same amount of powder will be required near the camera, as the additional flash for the shadows in the rear of the

room will only take the place of the additional amount of ribbon or powder which would otherwise be required in the main or secondary light to fully illuminate the far distance. The results will be superior if the extra light be employed, for by this means there will not be as much contrast as when all of the source of illumination is very near the camera, or, in other words, from the front of the room. The shadow flash should be only a light one, from $\frac{1}{4}$ to $\frac{1}{8}$ the strength of the main light.

534. **Pure Magnesium Powder.**—Pure magnesium powder ignited with a special lamp is generally employed for illuminating interior photographs where figures are not included. The number of grains of powder will depend entirely upon the size of the room, color of the walls, as well as color of the furniture, etc. As the magnesium machines usually hold a minimum of one ounce, the chamber may be filled and any portion of this amount required may be used. If the tube for *blowing the powder into the flame* is used, even illumination will be effected by blowing a few light puffs from different points.

535. Interiors of *halls, churches, stores, and other public places*, are made on exactly the same principle as the photographing of interiors of residences, the only difference being in the required amount of powder.

536. Where figures are included within the field of view, it will be necessary to use a flashlight compound instead of the magnesium ribbon or powder, as movement would result if either of the latter were employed owing to the prolonged duration of the flash. There are occasions where the magnesium powder may be employed on interiors where figures are included in the view, but in such cases the subjects must be informed that the exposure is not instantaneous and, therefore, a position should be given them which they can hold for a few seconds without movement. The magnesium machine should be held in the hand and by moving about from a position on the right to one on the left while lightly blowing puffs of magnesium into the

flame, a very even illumination can be given. *Never pass in front of the camera while the flame is burning.*

537. **Flash-Machines.**—Usually, where many figures are introduced, the regular flash-powder and a flash-machine will be found the most satisfactory, as it works instantaneously and there is no movement of any subject during the exposure.

538. When using the flash-machine on interiors, remember, that the larger the interior the higher you should place the lamp and, of course, the more powder will need to be used.

539. As each room, hall, store, church and other interior requires special handling and lighting, it is not possible to give detailed instruction regarding each case, but the general information contained in this chapter should be adequate to enable you to proceed in securing the very best of results. It is not advisable, of course, to attempt anything on such a large scale as this until you have used flashlight material in a small way, such as photographing the average room, a figure or even still-life subject. It requires the fundamental training which you will secure with these simpler subjects to acquaint you with the peculiarities of this branch of photography. For smokeless flashlight work on a large scale, see Vol. IX. .

Practice Work.

540. After having procured the necessary material for making of flashlights, it is advisable to first experiment in photographing the interior of a room or some inanimate object—the latter is preferable. Light this object in exactly the same manner as you would a person. Carefully load the flashlight apparatus which you employ, and proceed to make the exposure. A proof print should be made from the final negatives, with a memorandum of conditions noted on the back, and these proofs then filed in the proof file.

When, to your satisfaction, you can make a good negative of the still-life subject, proceed to make a Plain Portrait Lighting of a person, carefully following the instruction given for lighting, etc. Go about the work carefully and you will be successful. After your first experiments you will have less fear of accident and will be able to produce some very pleasing results. Proof prints should be made of all your first experiments with complete data noted on the back of each and all proofs should be filed in your proof file for future reference.

CHAPTER XXXI.

Difficulties—Flashlight Photography.

541. **Lighting Hard.**—The flashlight was too concentrated, too near the center, and not sufficiently diffused. Diffuse the light through muslin or similar cloth stretched on a frame, or use a secondary source of light. In any case, neither should be too near the object or subjects.

542. **Lack of Detail in Shadows.**—This difficulty will be experienced if the light is too concentrated, too near the sitter, or insufficiently diffused. If the correct amount of powder has been used, and the instruction in the preceding lesson carefully followed—and a reflector used to illuminate the shadow side of the face—a full amount of detail should be easily obtained.

543. **Eyes of the Sitter Closed.**—The subject, by watching your movements, knew approximately the moment you were going to make the flash, and the eyes were instinctively shut at the moment of exposure. Whenever possible, the ordinary illumination of the room should be maintained while making the exposure. It is a mistake to turn down the lights, as the eyes used to darkness are sure to shut or appear unnatural when the flash is made. Subjects should always be advised to look away from the light so as to receive the illumination more from the side. This will give more of a Portrait Lighting and will also overcome the closing of the eyes during exposure.

544. **Misty, Foggy Appearance of Portrait.**—The light from the flash has been reflected onto the lens and has fogged the plate. See that the flashlight is clear of the angle taken in by the lens. If not, shield the direct rays from the camera, and see also that the light is not reflected into the lens from mirrors or picture glasses. The smoke from a previous flash, if hanging about, even if only faintly visible will produce an effect of fog. Lower the windows and open the doors after an exposure. This will create a draft and carry off the smoke.

545. **Portrait Flat and Lifeless.**—The lighting has been too

much in front of the sitter, and probably too low. The best position for the light is at an angle of 45 degrees from the sitter. The light should be at least 8 feet above the floor for a standing figure. A three-quarter side lighting, with reflector, gives the best results. Too much powder, or working the reflecting screen too close to the subject, will give flatness.

546. **Flash-Compound Refuses to Ignite.**—The powder is damp. Flash-powder should be kept very dry and handled carefully. Be sure you have not used pure magnesium in place of flash-powder.

547. **Flash-Lamp Explodes.**—A flash-compound has been used in a lamp intended for the pure magnesium metal powder. The greatest of care must be exercised in this respect, and under absolutely no circumstances use a flash-mixture in a closed lamp which is intended only for pure magnesium powder. If in doubt as to whether the powder you are using is magnesium or flash-powder, test a small quantity of the powder before using it in the machine, by placing a small amount of powder on a pan and igniting it with a match or long taper. *If the powder explodes with a flash it is flash-powder you are using; if it cakes up and only flickers it is magnesium powder.*

548. **No Image on Plate.**—If upon attempting to develop the plate, you find that after a sufficient length of time no image appears, the trouble is no doubt due to the fact that the shutter was not open when the flash took place. It is advisable to experiment in manipulating both the shutter and the lamp (without having the lamp loaded) so as to become thoroughly accustomed to the manipulation. It often happens that one also forgets to draw the slide of the plate-holder.

549. **Focus.**—Sometimes trouble will be experienced in securing a sharp focus, owing to the lack of illumination in the room. Especially is this true when working at night. All of the ordinary illumination of the room should be used, and if this is insufficient to properly illuminate the face so that you can see it distinctly on the ground-glass, have some one hold a lamp, match, or candle close to the subject's face. If a group is being photographed, a lighted candle may be held by the member in the center of the group and the member at each end, and you can then sharply focus on the flame of the candle. Always focus with the lens wide open.

550. **Proper Amount of Powder to Use.**—The required amount of powder is governed by many different conditions—the color of the walls and ceiling of the room, the distance the lamp is from the subject, size of stops, speed of plate, etc. In the lesson proper we have given approximate amounts of powder to use under vary-

ing conditions, but the exact amount can only be ascertained by trial. A record should be kept of each and every exposure made, so that you will be able to profit by previous experience.

551. **Magnesium Lamp Chokes Up.**—This difficulty will be caused by not giving that even, steady pressure to the air which forces the powder into the flame uniformly. A few repeated trials will give you a perfect idea as to the manner of operating this kind of a light. The magnesium lamp should be cleaned each time immediately after use. If this is done there will be little danger of the lamp choking up.

CHAPTER XXXII.

Reflex Camera in Conjunction with Flashlamp.

By M. J. Shiels.

552. **Introduction.**—Serious workers frequently refuse to consider the hand-camera otherwise than suitable for recreative work, owing to the uncertainty of the results it yields, and leave it out of consideration for professional work. The aim of this article is to demonstrate how these objections are entirely overcome in the Reflex cameras, which, although hand-cameras in the strictest sense of the word, give a greater control over the combined operations of focusing and exposing than is obtainable with tripod cameras of all types.

553. **Essential Feature of the Reflex Camera.**—The essential feature of the Reflex camera consists in the placing of the ground-glass in the top of the camera, whereas film or plate occupies the usual place in the back. A mirror placed at an angle of 45° to the plane of the sensitive plate or film reflects the image from the lens to this ground-glass. This arrangement permits of having the ground-glass and the plate both ready in their operative positions at the same time, whereas in tripod cameras the insertion of the plate or film renders the ground-glass inoperative.

554. **Ready for Instant Exposure.**—In all cases where continuously moving objects are to be photographed, the time required to insert the plate renders the previous focusing useless, as at the time of the exposure the objects may have approached toward or receded away from the lens sufficiently to require a different adjustment of the latter. The Reflex construction permits of focusing up to the

very instant of exposure, and is thus really the only practical instrument for this kind of work.

555. **Compared with Twin-Lens Cameras.**—It may be said that twin-lens cameras perform the same service, but this is not so in practice nor in theory. The finder lens of a twin-lens camera, usually placed *above* the photographic lens, never shows the same picture as that which will be developed on the plate, owing to the different position of the finder lens. Particularly when the subject is nearby will the difference in foreground as shown and as photographed be sufficient to produce faulty results.

556. As a twin-lens camera is bulkier, and neither simpler nor cheaper than the single lens Reflex camera, which shows under all circumstances exactly what will appear on the picture, it is easily understood why this latter type of construction is so universally preferred.

557. **Focusing Hood.**—In order to obtain full advantage of the focusing facilities of the Reflex camera the focusing hood has been most carefully designed. It is of sufficient length to permit of placing the eyes directly on it. The hood itself is perfectly rigid when extended, and its top is provided with a plush-covered flexible eye-piece, fitting tightly around the eyes and completely excluding all outside light. It shows the ground-glass from corner to corner, and the image appears with its full brilliancy, enabling the operator to focus quickly and with precision. Even with a diaphragm stopped down to *f.* 16 the image has all the necessary strength to allow accurate focusing. This would be impossible if its brilliancy should be dimmed, by light entering through the focusing hood.

558. The necessity of a hood which completely excludes the outside light becomes most evident when the light on the subject is extremely bright, as in plain bright sunshine views on the water, and snow scenes. When looking at such scenes the pupil of the eye contracts to a small opening, thereby preventing one from seeing the image immediately and focusing accurately unless that image is perfectly sheltered and protected from false light. Only



Photos by Shields and Keller, N. Y.

Illustrations Nos. 42, 43, and 44
Examples of Work with Focal Plane Shutter
See Paragraphs Nos. 559, 560, and 570

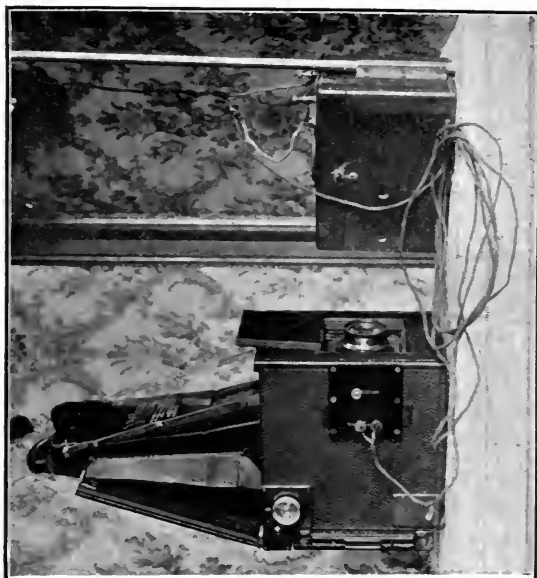

a close-fitting hood, as provided on the Reflex cameras, will properly cover this condition. A further material advantage offered by this construction, is that the forehead is used to steady the camera instead of the chest, insuring thereby increased steadiness.

559. Advantages of the Focal-Plane Shutter.—The focal-plane shutter used on the "Reflex" allows the widest range of speed. Besides time exposures, it will give instantaneous exposures from five (5) seconds to 1-1200 of a second, and requires only a few seconds to change to these extremes. The ability of these shutters to make the fastest exposures has led many photographers to place the Reflex camera in a special field of usefulness. Their field, however, is far wider, and they should be used in every instance where accurate focusing on movable objects is required, immaterial if they move rapidly or slowly. The illustrations accompanying this article aptly explain this point. The picture of Major Delmar (See Illustration No. 44), who was going at the rate of $2.08\frac{1}{2}$ on a half-mile circular track when this plate was exposed, was made in the 1-1200 of a second, and is a typical example of the speed work of which these cameras are capable. The children on the swing (See Illustration No. 42), were photographed in 1-250 of a second, and this picture is here reproduced to illustrate the perfect control a Reflex camera offers when it becomes necessary to "divide" the focus. The full opening of the lens (a No. 4 Goerz Celor of $9\frac{1}{2}$ " focus) was used, and it was thus required to carefully set the lens to the most advantageous focus. Besides this, the proper moment of exposure and the most satisfactory composition could be determined with the greatest facility and certainty.

560. Adapted to Interior Portraiture.—The vivacious baby boy (See Illustration No. 43), required an exposure of 1-5 of a second only, but nevertheless moved sufficiently to make focusing right up to the instant of the exposure an absolute necessity. As this last named picture was obtained in a rather unusual way, we give illustrations of this device and describe more in detail how an ordinary

Reflex camera can be used with perfect success in the studio and the living room.

561. **Combination Daylight and Flashlight Exposure.**—The window shown in this picture being the only source of daylight, it was necessary to resort to combination light-

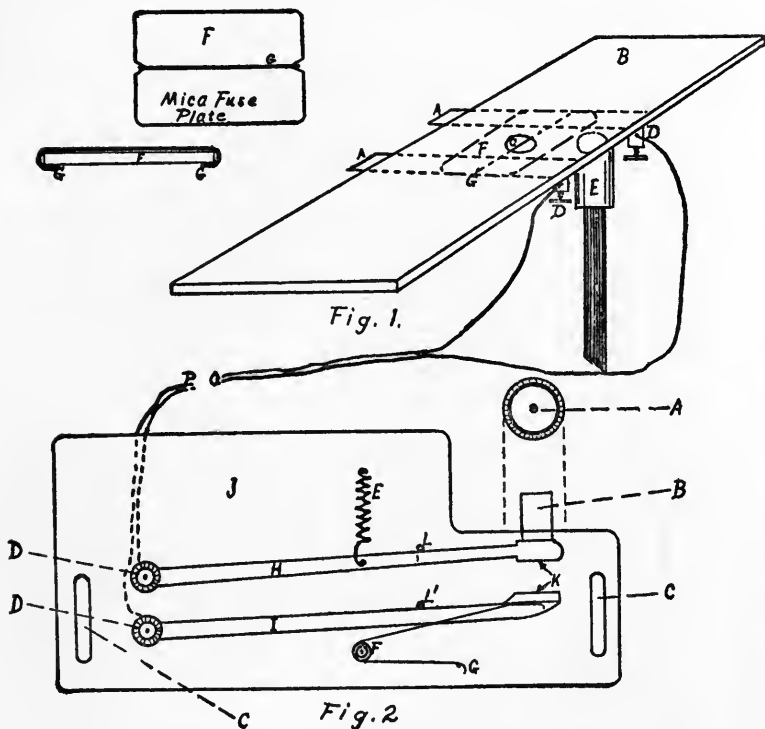

Illustration No. 47
Diagram of Electric Connection for Reflex Camera
See Paragraph No. 563

ing, for which purpose an electrically controlled flashlight, charged with 10 grains of flash powder, was used. The shutter of the Reflex camera was opened to the full width of the plate, and wound up just enough to completely *uncover* it. The flashlight was placed in position and the circuit breaker attached to the release button of the Reflex.

The camera was then focused in the usual manner and the exposure made, same as if daylight only was used. The electric contact is made just before the release button reaches the end of its course, thus releasing the shutter at the instant the flash is made. In this manner the child and the dog, together with the interior of the room, are produced by the flash, whereas the view outside the window is obtained by the daylight.

562. Flashlight Equipment.—Our illustration of this equipment shows how simple and portable is the whole device, and how well adapted it is to be taken to customers' residences when required. The extension support of the lamp is formed by three sections of telescoping brass pipes, which provide the necessary elevation of the lamp for the various kinds of pictures. The battery box itself forms the base and is amply stable for this purpose. This disposition also simplifies the wiring. The larger view of the camera and the battery box plainly show this in detail. The switch plate is attached to the outside of the Reflex camera and carries two binding posts, each one of which is connected with one of the wires of the two-wire cable, the other ends being spliced on wires connecting the lamp with the battery. (See Illustration No. 46.)

563. Construction of Flashpan.—The flashpan of the lamp (See Fig. 1, Illustration No. 47) is made preferably from a thin piece of slate (B), about 7 inches long, 2 inches wide, and as thick as an ordinary school slate. A $\frac{1}{2}$ -inch hole (C) is drilled in the middle, and on either side of this hole a flat strip of thin German silver (A, A), $\frac{5}{16}$ " wide and $\frac{1}{8}$ " thick, is held against the under side of the flashpan, by means of screws (D, D), which serve at the same time as the binding posts for the electric wires. A metal or wooden socket (E) is also attached to the underside of the flashpan, permitting of its being attached on top of the telescopic stand. In case this socket is of metal, care should be taken to keep it free from contact with the binding posts and springs, to prevent short circuiting.

564. The Fuse.—The fuse is made from a thin piece

of mica, 1" x 1½" (F, Fig. 1, of Illustration No. 47). In the middle of the short sides a small incision is made with scissors or pocket-knife, and a piece of thin German silver wire 3-1000" in diameter and 2" long is laid over this mica, the ends projecting equally on both sides (G, G), and then bent back and under against the mica plate, thus forming a double-ended hook which cannot slip out of position. The fuse so prepared is slipped in between the springs (A, A) and the flashpan (B), so that the wire (G) appears through the middle of the opening (C).

565. **Electric Current.**—The current is provided by a battery of six ordinary dry cells. For convenience sake they are placed in a suitable wooden box, with binding posts on the lid, which also carries an ordinary circuit breaker or switch. The cells are to be connected in series. The switch is not absolutely essential, but is desirable as an extra safety device, being left open until all preparations are completed, and closed only just before the picture is focused.

566. **Release for Making Exposure.**—The equipment is finally completed by constructing and attaching a special *circuit breaker* to the release button of the Reflex camera. A view of this is shown in Figure 2 of Illustration No. 47. The base (J) is a piece of vulcanite or other suitable insulating material. The two rods H and I are pivoted to the vulcanite piece, by means of the binding posts D, D, which latter thus serve two purposes—a pivot for the rods and connecting posts for the electric wires. The ends of the rods at K are kept separated by means of the coil spring E. The upper rod H is further held in position by the little pin L, while the lower rod I is kept from being forced upward by means of the pin L'. The spring G, which is wound around the pin F, keeps the rod I in constant contact with the pin L'; so when the upper rod is forced downward by pressure on the button A, there will be instant contact at the point K. A is the shutter release button on the Reflex camera, and when this is pushed downward to make the exposure, it comes in contact with

the projection B, which latter is fastened securely into the rod H. This circuit breaker should be covered, as shown in Illustration No. 46, so the mechanism will not be disarranged.

567. Adjustment of Release and Circuit Breaker.—In order that the circuit breaker may be adjustable in height, the two slots C, C are cut in the vulcanite base, and this little instrument is attached to the side of the camera with wood screws. Practice has shown that it is quite safe to adjust this device so that contact of rods H and I is made at K when the lower edge of the mirror in the camera is on a line with the top of the lens.

568. Electric wires are fastened to the binding posts D, D, Figure 1, on the bed of the flash machine, and the other ends of these wires (O) attached to the binding post in the battery box. The ends of the wires (P), Figure 2, are also connected to binding posts on the battery box. These two sets of posts should be connected by means of a switch, which should be disconnected excepting when ready to make the flashlight exposures. The exact instant that the exposure is made can be easily determined by means of a one-half candle power incandescent lamp, to be held against the binding posts of the flashpan.

569. Caution.—It is, of course, necessary to do this before placing either the fuse or the powder charge in the pan, to prevent accidents. This test, moreover, proves the soundness of all contacts and secures a prompt firing of the charge when operating. The completed apparatus is clearly shown in Illustration No. 45.

570. Making Exposure.—Having thus prepared the installation, the camera is focused and the exposure made in exactly the same manner as if daylight were used, not forgetting, however, that the shutter must be set with its full sized opening in front of the plate, and not wound up entirely. The release of the shutter takes place immediately after the firing of the flash and stops the additional daylight exposure, if any. The lens opening should be regulated accordingly, and in its turn determines the quantity

of flash powder. In the example illustrating this article a Goerz Dagor, Series III, No. 3, was used, with an opening of f. 12, the powder charge being 10 grains, as previously stated. The picture of the race-horse was obtained with a Goerz Celor, Series IB, No. 4, at its full opening of f. 5.

571. The electric flashlight, as described, is the invention of Mr. E. F. Keller, of New York, to whom we are greatly indebted for this valuable adjunct to the Reflex camera, of which he is an expert user.

CHAPTER XXXIII.

PHOTOGRAPHIC LENSES—THEIR NATURE AND USE.

By S. Lawrence

(Of the Bausch & Lomb Optical Co., Rochester, N. Y.)

572. The function of a photographic lens is to project upon the sensitive plate an image of some object or objects situated in front of the lens.

573. **Function of the Lens.**—From an object in front of the lens light is reflected in all directions. Some of this light is gathered in by the lens and transmitted to the plate, there to form an image of that object. The rays of light which travel from the object toward the lens are bearers of the image. The function of the lens is to assume control of these image bearing rays and convey them, steer them so to say, to the plate, in such a manner that the image there formed by them will be a true representation of the object. From each and every point of that part of the object facing it a set of rays reaches the lens and these are transmitted to the plate, where they form an image of that point—each image point thus being a representation of its corresponding object point. In order to understand how this is accomplished, it is necessary to have some knowledge of light and optics—the composition and transmission of light.

574. It is not my purpose to dwell on the theory of light but to explain in a simple manner and with the least possible use of scientific terms and mathematical formulae, the elementary principles of optics involved in lens construction, and the properties of photographic lenses as based on those principles.

575. One of the first and simplest optical truths is that *light travels in a straight line* as long as it continues *in the same medium*, or in passing *from one medium into another of the same density*. When it passes from one medium into another of *different density*, if it enters the new medium at right angles to its surface, it continues in a straight line; if it enters at an oblique angle, it is bent out of its original course and proceeds in a different direction.

576. Thus a ray of light Fig. 1 (a) entering from air into another medium, say glass, (A) at right angles to its surface—perpendicular, or normal, to the surface of the new

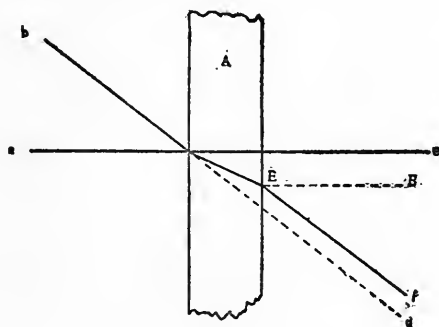

Fig. 1

medium—will proceed straight through, without deviation. If the two surfaces of the new medium are parallel, the direction of the ray will be perpendicular, or normal, to the second surface also, and again, in passing out, it will suffer no deviation, thus passing through and out in a straight line (a c).

577. **Refraction.**—Another ray (b), entering at an oblique angle, will be bent out of its original course (b d). Glass having greater density than air, the ray, on entering, will be bent *towards the normal* (a c) (a line perpendicular to the surface of the new medium at the point of entry) and it will proceed in its new direction till it reaches the opposite surface (E). Passing here from a denser medium, glass, into a rarer medium (one of less density), air, at an oblique angle, it is again bent (E f), this time *away from the normal*

(E E). This bending is termed *refraction*. It takes place whenever a ray of light passes at an oblique angle from one medium into another of different density. The surface at which it takes place is called a refractive surface. The angle which the entering (incident) ray forms with the normal at the point of entry (incidence) is termed the *angle of incidence*; the angle formed by the refracted ray at the same point is termed the *angle of refraction*.

578. The degree of refraction depends upon two factors: I.—the angle at which the incident ray meets the refractive surface: II.—the relative density and consequent relative refractive power of the two media.

579. This refractive power of glass is of value in the construction of photographic lenses, for it makes it possible to control the image bearing rays, to make each set of rays emanating from a point (a point in the object) converge to a point (the corresponding point in the image) and form a correct image.

580. **Dispersion.**—But glass possesses at the same time another property which is a distinct disadvantage to the lens maker. A ray of sunlight falling on a prism of glass



Fig. 2

would be bent according to the laws of refraction and proceed as in Fig. 2, providing that the prism had no other effect on it than to bend it. But if we place a white screen in its path after it emerges from the prism, we find that instead of a disc of white light, as we would expect we have a band of color, Fig. 3. This shows us immediately two things; first—that a ray of white light is composed of several rays of different colors, red, orange, yellow, green

blue, indigo and violet, and second—that the different colored rays are differently refracted, and consequently separated, in passing through the prism. This separation, spreading apart, is termed *dispersion* and is caused to a different degree by different kinds of glass.

581. **Visual and Actinic Rays.**—The band of colors is called the *spectrum*. The different colored rays have different luminosity, the yellow being the brightest. But this is not the only difference which concerns us. If the spectrum

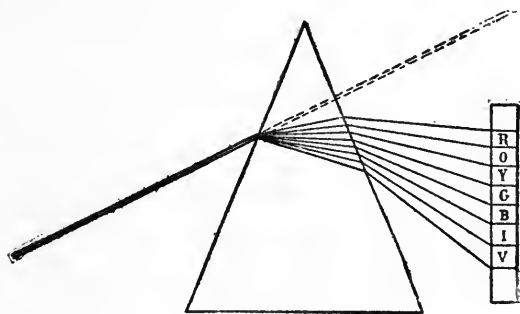

Fig. 3

falls on a strip of photographic printing out paper, we find that the paper soon begins to darken at and beyond the violet, but that no darkening, even after quite a while, is perceptible beyond the blue toward the yellow. This shows that the blue and violet rays have the strongest action on the sensitive silver salts. Thus we distinguish between I.—the *luminous* or *visual* rays which form the visible photographic image, and II., the *actinic* or *chemical* rays, which affect the sensitive surface on which the image is received.

582. **Chromatic Aberration.**—If we have two prisms identical in shape, made of the same kind of glass and placed base to base, a pair of rays entering those prisms as shown in Fig. 4, will be similarly affected. A lens made of a single piece of glass (a “simple” lens) and corresponding in shape to the combined prisms, as also shown in Fig. 4, would simply be a modification of those prisms (a lens being in effect a com-

bination of an infinite number of prisms of different angle) and would produce a similar effect. For photographic purposes such a lens would be of very little value. Let us as-

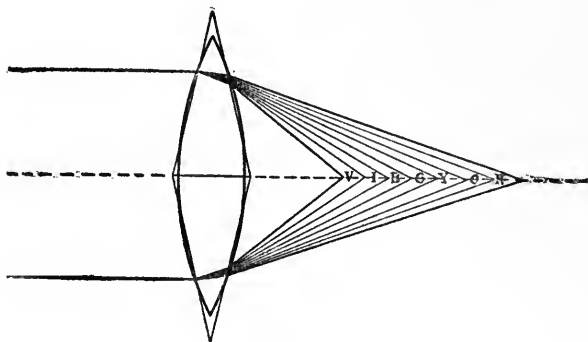

Fig. 4

sume that the two rays have proceeded from a point on some object. Instead of meeting as *one* pair, at *one* point, to form *one* image, they are divided up into *several* pairs meeting at *different* points and forming *several* images, each pair of rays of the same color forming an image at their point of meeting. The most luminous image is the one formed by the yellow rays. Focusing this image as sharply as possible and exposing a plate, we do not get a sharp image in the negative. The reason is apparent. The blue and violet rays have the strongest action on the plate. These rays have their meeting point, their focus, nearer to the lens than the yellow rays and are consequently out of focus, forming only a blurred image when they reach the plate. The resulting image in the negative is therefore blurred; the yellow rays which would have formed a sharp image, having had no perceptible effect. The only remedy is to bring the plate closer to the lens where the actinic rays form a sharp image. This fault in a lens of bringing the actinic and the visual rays to a focus at different distances (in different planes) is called *chromatic aberration*—color aberration—and no lens formed of a single piece of glass can be free from it.

583. **Correction of Chromatic Aberration.**—Readjust-

ment of the plate for the plane of focus of the actinic rays—even though such a lens were perfectly satisfactory in other respects—is inconvenient, except when the lens is always used at the same distance from the object. It therefore becomes desirable to so construct the lens, that the actinic and visual rays will come to a focus at the same point. Figures 4 and 5 together will give us an idea of how this may be accomplished. A pair of prisms placed base to base as in Fig. 4, and a simple lens corresponding in shape, will have an inward bending and spreading tend-

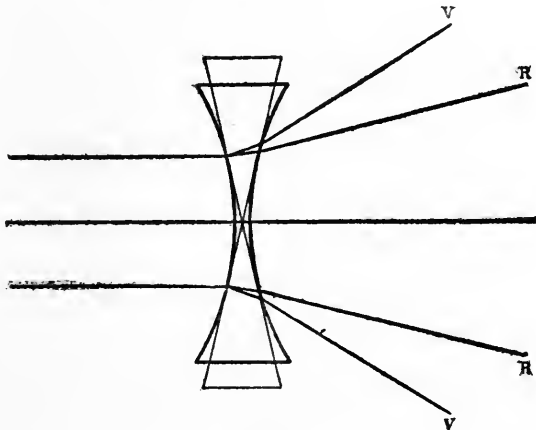

Fig. 5

ency, bringing the violet rays closer in towards the lens. Another pair of prisms, placed apex to apex, as in Fig. 5, and a simple lens of corresponding shape, will have an opposite, outward tendency, bringing the violet rays farther out and away from the lens. The inward tendency of the one is opposed by the outward tendency of the other, and it is not very difficult to see from Fig. 4 and 5 that by combining the two lenses, choosing for them glass of proper refractive and dispersive power and giving them suitable curves, we can re-combine the yellow and the violet, the visual and the actinic rays and converge them toward the same point. This is how the optician corrects chromatic

aberration in a photographic lens, and a lens thus corrected is called *achromatic*.

584. **Spherical Aberration.**—Another inherent fault in a lens is *spherical aberration*, due to the spherical shape of the lens, and it may be described as the inability of a lens to bring both the central and marginal rays of the same pencil of light to a focus at the same point. Suppose that in Fig. 6 a set of rays emanating from the same point on an object enter the lens. The function of the lens then is to bring these rays together in one and the same point, to con-

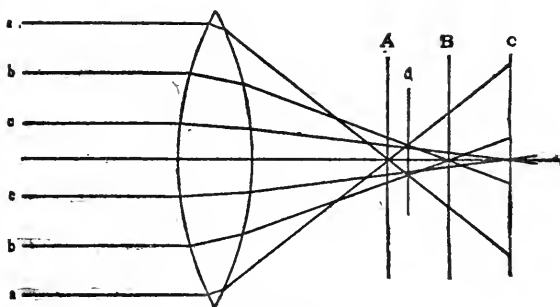

Fig. 6

verge them to the same focus and make them all form *one* image point corresponding to the object point from which they all emanate. But the rays passing through the margins are bent more than those passing through the center, that is, the marginal rays are brought to a focus nearer the lens than the central rays. In Fig. 6 each pair of rays, aa, bb, cc, meets and forms an image at a different point, aa nearest to, and cc farthest away from the lens, and consequently we can get no distinct image point, for where we would get a distinct image formed by one pair, we also get, superimposed on it, the blurred images formed by the two other pairs.

585. **Correction of Spherical Aberration.**—It is evident from Fig. 6, that we can, to quite an extent, remedy the trouble, by cutting off the marginal rays. If by interposing a stop either in front of or behind the lens we cut off aa

and bb we can get a distinct image formed by only the central pair cc. This, however, means a loss of much illumination and it therefore becomes incumbent upon the optician so to construct the lens, if possible, that it will converge both central and marginal rays of a light pencil to one point. It is accomplished in the same manner in which chromatic aberration is corrected—by combining two or more glasses of suitable character and suitable shape. A lens is commonly said to be *aplanatic* when corrected for both spherical and chromatic aberration.

It should be well understood that spherical aberration, caused by the unequal bending of individual rays (members of the same light pencil) passing through the different portions of a lens is distinctly different from chromatic aberration, caused by the separation of the different colors in each one of those individual rays. Chromatic aberration refers to the separation of the *constituent parts* of the ray, caused by their unequal refrangibility; spherical aberration refers to the bending of those constituent parts collectively—the bending of the *ray as a whole*. Thus we may presume that within each ray in Fig. 6, the actinic and visual colors are combined, but a ray as a whole suffers more bending the nearer to the edge of the lens it passes.

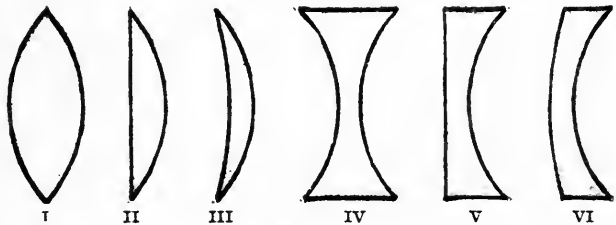

Fig. 7

586. **Forms of Lenses.**—Lenses are divided into two classes: *positive* or converging lenses which bend the rays toward the axis; *negative* or diverging lenses which bend the rays away from the axis. The various forms of lenses are shown in Fig 7. Positive lenses are, I., double convex; II., plano convex; III., convex meniscus. Negative lenses

are, IV., double concave; V., plano concave; VI., concave meniscus.

587. A lens surface is either plane or curved, and the curved surface is a perfect portion of a sphere. The *principal axis* (often called only the axis) of a lens is a straight line passing through the centers of curvature if both surfaces are curved, or the center of curvature and the center of the plane surface. A ray of light coinciding with the principal axis will pass straight through the lens, without deviation. When two or more lenses are used together, either in one combination or in different combinations, their principal axes must coincide—there must be one common axis for all of them. To so adjust them—center them—is a very delicate operation.

588. **Astigmatism—Anastigmat.**—Astigmatism is the inability of a lens to render at the same time a sharp image of horizontal and vertical lines situated in the same plane. It exists only in oblique pencils,—pencils of light passing through the lens obliquely, not parallel with the axis—and affects the marginal definition. It is thus possible for a lens which is astigmatic to render both horizontal and vertical lines equally sharp at the same time in the center of the plate, but only one set at a time, either the horizontal or the vertical, at the margin of the plate. When a lens is free from astigmatism it is termed an *anastigmat*.

589. The following is a simple **test for astigmatism**. Draw a black cross on a white card and set it up in front of the lens so that one bar is horizontal and the other one vertical. Focus it on the center of the ground-glass, and both bars will be equally sharp at the same time. Then move either the camera or the card to one side, until the image of the cross is near one corner of the ground-glass. If both bars show equally sharp at the same time, the lens gives freedom from astigmatism over an area at least as large as the ground-glass. If astigmatism is present, only one bar can be focused sharply at a time. The distance which the ground-glass must be moved to bring the other

bar in focus, measures the degree of astigmatism, the astigmatic difference.

590. A set of rays emanating from one point should be brought together in one point and form one image point. However, if they pass obliquely through the lens, they are not brought to one point, but to two lines (or properly speaking, two very attenuated ellipses) some distance apart and at right angles to each other. The image point is extended into a vertical line (or ellipse) nearer the lens, and into a horizontal line (or ellipse) farther from the lens. Somewhere between the two, at a point where a cross section of the rays is most nearly circular (the "circle of least confusion") is the best mean focus. The smaller this cross section is, the more nearly it becomes a point and the less apparent is the effect of astigmatism.

591. Being confined to oblique pencils, unless the lens is very poorly made, astigmatism is not present in the center of the field. It increases toward the margin, and, as with spherical aberration, the difficulty of correcting it increases as we approach nearer to the margin and as the lens is given a larger relative opening.

592. **The Field of the Lens.**—The *field of a lens* may be defined as the surface (imaginary) on which the image is formed. This must not be confounded with the surface (sensitive or otherwise) on which we intercept the image. A surface in geometry is considered to be made up of innumerable points. The image-bearing rays emanating from innumerable points on the object, form correspondingly innumerable image points, and we can imagine a surface made up of those image points. Now let us suppose that we point our lens at right angles to a flat object. The surface of this object we consider to consist of innumerable, infinitely small points from each one of which a set of rays enters the lens. Their course is so controlled that each set of rays is conveyed to one point, and all the points together constitute the surface which we term the field of the lens. As each point is an image point, we also say that the image is formed on that surface. If all the points are in one plane,

that is, if they form a flat (plane) surface, we say that the field of the lens is flat, and the image is flat. In other words, a lens has a flat field when it is capable of producing a flat image of a flat object. Perfect flatness over the whole field

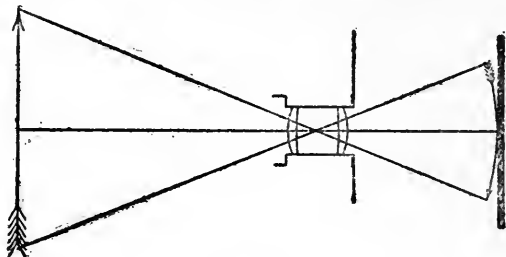

Fig. 8

of a lens has not yet been attained, the field of all lenses being more or less curved, concave towards the lens; but the best modern lenses come very near perfection.

593. **Curvature of the Field.**—After what has just been said, the term curvature of the field will hardly require any explanation. Fig. 8 shows a curved image of a straight object. If the object were a flat surface, it is evident that the image would be saucer like in shape. This defect is to a very great extent inherent in lenses of the old type, as flattening of the field in those lenses can be effected only to a very limited extent without causing too much astigmatism.

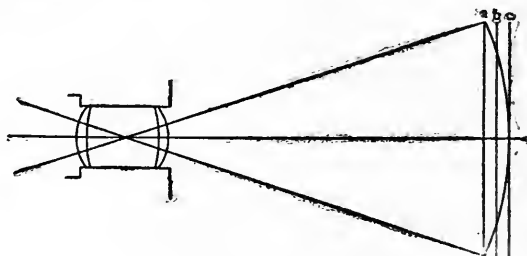

Fig. 9

594. The disadvantage of a curved field is apparent from Fig. 9. The surface on which we project the image being flat, it would evidently be impossible to find a position

for it where the different portions of the image would be rendered equally sharp, or even nearly so. In the plane of "c" the center only would be in focus; in the plane of "a" the margin only; and intermediate positions, as "b" for instance, would give us only intermediate portions of the image sharp. Reducing the aperture of the lens (stopping down) and thus gaining depth of focus, we might find an intermediate position where the whole image would be fairly well rendered; but as reduced aperture means reduced speed of the lens, the effort of the lens maker has been directed towards giving the lens as flat a field as possible without impairing its perfection in other respects. The flatter the field the larger is the area over which it will coincide with the flat surface on which the image is projected, consequently the greater is the covering power of the lens, providing it is at the same time capable of giving critical definition, over that area.

595. Circle of Illumination.—The aperture of the lens being circular, the rays of light passing out from the lens form a cone of light, and the field of the lens is therefore circular. A cross section through this cone at right angles to the axis of the lens will be a disc of light, smaller or larger as the section is taken nearer to or farther from the lens. This disc is the circle of illumination. If we take the cross section at the *equivalent focal distance* (see paragraph No. 608) from the lens, the disc is the circle of illumination at that distance. It is also referred to as the image circle, because the area of the disc is also the area of the field—the surface on which the image is formed—and when the diameter of image circle or circle of illumination is referred to in lens makers' catalogues, it means the diameter of the field at the distance of the equivalent focus.

596. Angle of Field.—The *angle of field* is the angle included between the lines drawn from opposite ends of the diameter to a certain point in the lens (the node of emission). For our purpose it will be sufficient to imagine the two lines drawn to the center of the diaphragm opening in

a doublet lens. As this angle is narrower or wider, the lens is relatively a narrow angle or a wide angle lens.

597. **Angle of View.**—Angle of view is differently given—sometimes on the longer side of the plate and sometimes on the diagonal (a straight line joining two opposite corners). In the former case it is included between the lines drawn from the opposite ends of the plate, in the latter case between the lines drawn from the two opposite corners, to the same point in the lens. If the two lines, after crossing each other, are continued through and out in front of the lens, the amount of view included between them will be the amount included on the plate, either from end to end or from corner to corner.

598. **Wide-Angle Lens.**—The term “wide-angle lens” is very often popularly misunderstood. All lenses of the same focal length will form an image of the same size, will include the same angle, on the same plate, provided they are capable of covering the plate, but a lens built especially for wide-angle work will have a larger field—a larger diameter of field in comparison with its focal length than a rapid (narrow angle) lens of the same focus—and will thus be capable of taking in a larger amount of view *on a larger plate*.

599. **Defining Power and Definition.**—The terms “defining power” and “definition” are often used indiscriminately to convey the same meaning. There is, however, a difference—the difference between cause and effect. Definition is the effect, the result of the defining power of the lens. We have spoken of the image as made up of points, image points formed by rays of light reaching the lens from points on the object. If all the rays reaching the lens from one object point could be converged to one point, the image of the point would be a point. In reality, however, it is not a point but a tiny disc. The greater the defining power of the lens the more nearly to a point the rays are converged, the smaller is the disc (the more nearly it becomes a point), and the finer, or sharper, is the definition. “Sharpness,” therefore, as we can readily see, is merely a

matter of degree, and the question is, when can the photographic image be considered "sharp?" A disc of not more than 1-100 inch diameter appears as a point to the unaided

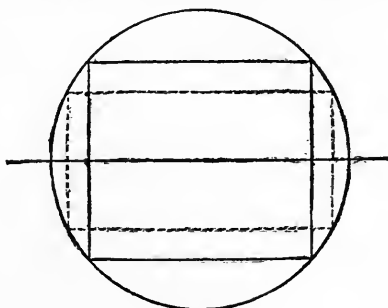

Fig. 10

eye at a distance of 10 or 12 inches, hence an image made up of such discs will appear sharp when viewed at such distance.

600. **Covering Power.**—The *covering power* of a lens depends on several factors—the area and the curvature or

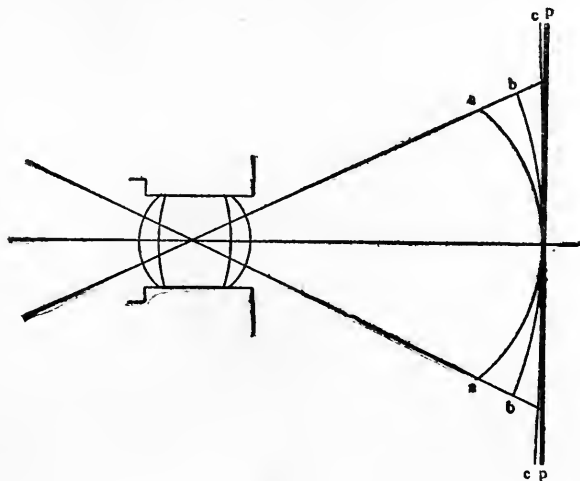

Fig. 11

flatness of its field, the area of critical definition (see paragraph No. 602), evenness or unevenness of illumination, and last but not least, the relative aperture of the lens. The ex-

treme limit of covering power is determined by the area of the field. The largest plate a lens can under any circumstances cover, is the largest one which can be placed within its image circle; that is, a plate the diagonal of which is equal to the diameter of the image circle. If in Fig. 10 the circle represents the field of a lens, it is evident that the largest plate fully covered would be one, the corners of which would come out to the edge of the field. The plate could vary in shape, but no matter what the shape, the diagonal of the plate would be the diameter of the field.

601. **Curvature.**—How curvature or flatness of field affects the covering power, can be understood from Fig. 11. The greater the curvature, the smaller is the area which is sufficiently flat to coincide with our plate (p). The three curves, aa, bb, cc respectively, may be taken to represent the comparative curvature of three types of lenses, the portrait lens, the rapid rectilinear and the anastigmat lens. The superiority of the anastigmat over the two older types is too apparent to require any further explanation.

602. **Critical Definition.**—The area of critical definition is an important factor. The larger the area over which

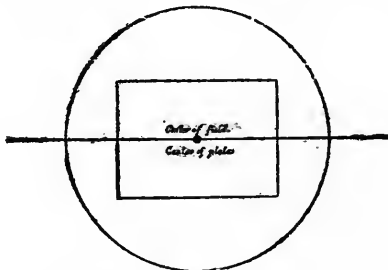

Fig. 12

the lens gives critical sharpness, everything else being equal, the greater is its covering power. This area can be extended by reducing the aperture of the lens, thus excluding the more or less imperfectly corrected marginal rays, and having the image formed by the more central and more perfectly corrected rays. The area of best definition being in the central portion of the field, the most advantageous

position of the plate is as shown in Fig. 12, the center of the plate coinciding with the center of the field.

603. **Relative Position of Plate and Field.**—The position of the plate relative to the field, therefore, plays an im-

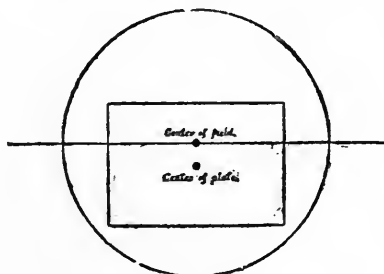

Fig. 13

portant part. Raising the lens and consequently raising the center of the field above the center of the plate as in Fig. 13, the upper portion of the plate would be within the area of *critical definition* but the lower portion, especially the corners, would be outside of it. More or less curvature of the field would also be perceptible. Lowering the lens or

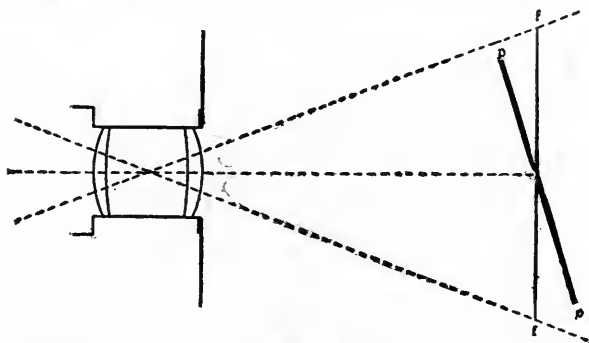

Fig. 14

moving it to one side, the effect would be similar at the top or at one end of the plate. *Remedy:* reduced aperture resulting in extended area of critical definition and increased depth of focus. If the plate is not at right angles to the axis of the lens but inclined, as (pp) in Fig. 14, (f represent-

ing the field of the lens), we are working under still greater disadvantage. The remedy here also is reduced aperture. Fig. 14 shows the position of the plate when the camera is tilted upwards, as is often necessary when we photograph a tall building at close range. If the lens is also raised, we add the disadvantage illustrated by Fig. 13.

604. **Evenness of Illumination.**—Unevenness of illumination is an inherent fault in the old lenses. Outside of a more or less limited area in the center of the field, the illumination rapidly diminishes towards the margin, causing a vignetted effect. A smaller aperture reduces this effect, but as it also reduces the speed, the evenness of illumination with a large relative aperture is a desideratum. A large area of critical sharpness, great flatness of field and evenness of illumination with a large relative aperture, are advantages which give the best modern lenses a vast superiority over the old ones.

605. **Focus.**—Focus is the point in which the rays of light meet after transmission through the lens, and at which the image is formed. In Fig. 15 a certain luminous point

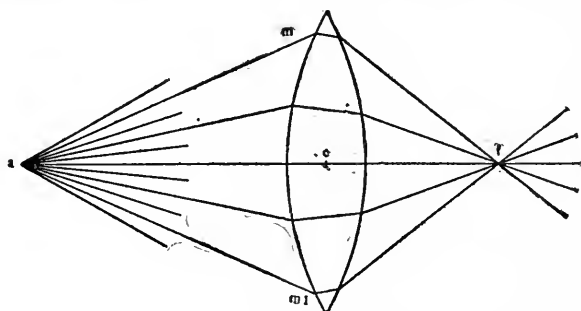

Fig. 15

(a) on an object sends a number of rays in the direction of the lens. Those which fall upon the lens (as do all the rays included between m and m^1) are so directed that they all pass through the same point (f). They all meet in this point, and this common meeting point for them all is their focus. We also say it is "the focus of the lens" for those rays, because it is the point to which the lens steers them.

606. If a lens were pointed toward the sun (it is not advisable to do so, however), the sun's rays would be converged to a point behind the lens—the focus for solar rays, or the solar focus, *the principal focus of the lens*. We also term this point the focus for parallel rays, because, coming from such a distance, all the rays would be practically parallel when entering the lens. But in commonly speaking of the focus of the lens of the rays, we do not refer to their meeting point, but to the distance between this meeting point, the principal focus, and another point, the one from which the distance is measured. This point has been variously termed the “optical center,” the “center,” the “nodal point” or the “node” of the lens. It is nowadays termed the “node of emission,” and it is sometimes located within the lens, sometimes outside of it. In doublet lenses it is generally located sufficiently near the diaphragm to make it in most instances safe and accurate enough to measure the distance from there. For the sake of convenience, and to avoid going into explanations which might prove confusing, we shall here use the term “center.” Thus when we say that the focus of a lens is 10 inches, or that a lens has 10 inches focus, it means that the distance from the “center” of a lens to the point where parallel rays come to a focus, is 10 inches. Whenever the focus of a lens is given, it is always the focus for parallel rays. It is also referred to as focal length.

607. *The point where parallel rays meet is the principal focus. The distance from the “center” of the lens to the principal focus is the focal length (commonly referred to as the focus).*

608. **Equivalent Focus.**—If we could easily and accurately locate in any lens the point from which to measure, the exact focal length of the lens could easily be ascertained with perfect accuracy. In the case of an extremely thin single lens, like “B” Fig. 16, we could simply measure from its rear surface. The error would be infinitesimal, and the distance from lens to focusing screen, when focusing for parallel rays, would be the exact focal length of the lens.

Not so in the case of a doublet. The point from which to measure may be located within the lens, or it may be located outside of it. We therefore compare a doublet with a single lens as described which would produce the same size image as the doublet. The image formed by the doublet being equivalent in size to the image formed by the single lens, and as size of image depends on focal length, we say that the focus of the doublet is equivalent to that of the single lens. Placing the two lenses as in Fig. 16, in front of the same focusing screen, if we then focus an object the image

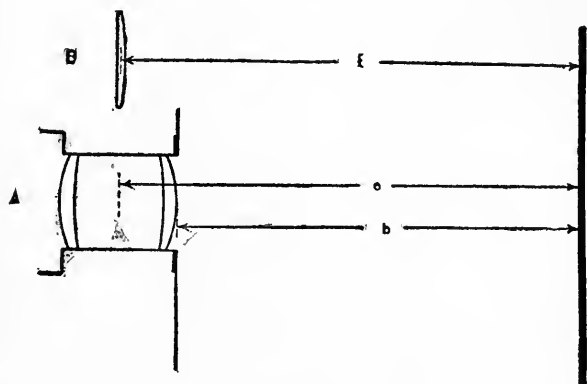

Fig. 16

of which we can accurately measure, and find that the two images formed by the two lenses have exactly the same dimensions, the two lenses must have the same *actual* focal length; but finding it inconvenient to accurately measure the focal length of the doublet, we only compare it with the single lens which we can measure exactly. If we were then to focus solar rays sharply with both lenses on the same screen, the distance (f) would be the actual focus of B, and the distance (e) would be the actual, and also the equivalent focus of A. The point from which to measure the focus (focal length) of the doublet would then be situated in the same plane as the point from which the focus (focal length) of the single lens is measured; the measurement of the focus of the single lens would also be the measurement of the focus

of the doublet; and if the actual focus of the single lens were 10 inches, its equivalent—the equivalent focus of the doublet—would also be 10 inches.

609. To focus an object, or to focus on or for an object, or to focus the image of an object, are expressions which hardly require any explanation. To focus is to so adjust the lens relative to the focusing screen, or vice versa, that we have the focusing screen in the plane where the image bearing rays are brought to a focus (the plane of sharp focus, or the focal plane for these rays), and thus give us a sharp image. When this is not the case, we say that the image—or the object—is “out of focus.”

610. **Back Focus.**—“Back focus” is a term which is sometimes used to indicate the distance from the rear end of the lens to the principal focus (the distance back of the lens—back focus). Its practical value is that it indicates the minimum camera extension required behind the lens. If we focus on an object situated at a moderate distance from the lens, other objects situated near to or far away from the lens are out of focus. If we focus on an object situated a great distance away, all objects situated beyond that distance may also appear in good focus. If we focus on nearer objects, one after another, we find that as the object nears the lens, the focusing screen is farther away from the lens. As the object is brought toward the lens, the image

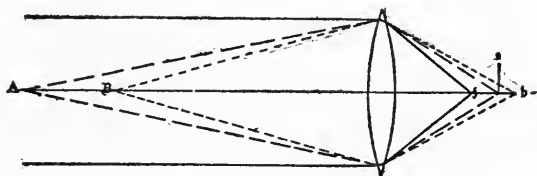

Fig. 17

recedes farther away from the lens, and the farther away the object, the more slowly does the image recede as the object moves, while as the object approaches near to the lens, the image recedes more rapidly. A change in distance between lens and object causes a change in distance between lens and image, and the image moves in the same direction

as the object. Fig. 17 illustrates this. When the object is a great distance away, the image is at (f); when the object is nearer, at A, the image is farther away at (a); when the object is still nearer, at B, the image is still farther away at (b).

611. **Conjugate Foci.**—For every distance between lens and object, there is a certain corresponding distance between lens and image. These distances are termed “conjugate foci” (conjugate, yoked together, coupled); the distance between lens and object is the anterior or major conjugate, and the distance between lens and image is the posterior or minor conjugate (except in enlarging, when their positions are reversed). With the variation of distance, we also find that there is a variation in the size of the image. As the object approaches, the image recedes and becomes larger; as the object recedes, the image approaches nearer to the lens and becomes smaller.

612. **Ratio of Distance and Size.**—A very simple mathematical rule governs both the relative distance of object and image from the “center” of the lens and also the relative size of object and image. The ratio of distance is also the ratio of size, for size of image compares to size of object as distance of image compares to distance of object. If the distance of the object is two, three or four times that

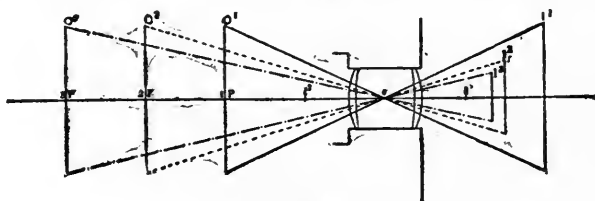

Fig. 18

of the image (the distance of the image then being one-half, one-third or one-fourth that of the object), the image is one-half, one-third or one-fourth the size of the object, and so on. Expressing the distances in multiples and fractions of focal length, we can formulate a very simple method of determining either distance or size.

613. When object and image, O^1 and I^1 Fig. 18, are of the same size, they are equidistant from the center (c) of the lens, and the distance in either direction is twice the focal length or the distance from the center of the lens to the principal focus. Now let us measure off the focal length in either direction from the "center" when f will be the principal focus, and f^1 its corresponding point in front of the lens. These points will be our starting points, the points from which we will measure. Let us call the focal length F (F thus being equal to cf and also equal to cf^1 , because either distance represents the focal length of the lens). We then find the object, O^1 , $1 F$ beyond f^1 , and the image, I^1 , $1 F$ beyond f . Then let us move the object another focal length away and place it in the position of O^2 , $2F$ beyond f^1 . The image will then be in the position of I^2 , $\frac{1}{2} F$ beyond f , and its size will be one-half the size of the object. Move the object another focal length away, to the position of O^3 , $3F$ beyond f^1 , and the image will be found at I^3 , $\frac{1}{3}F$ beyond f . Its size? Just one-third the size of the object. If the object is ten focal lengths beyond f^1 , the image is one-tenth of a focal length beyond f and is one-tenth the size of the object. A distance of 100 or 1000 focal lengths beyond f^1 in one direction means 1-100 or 1-1000 of a focal length beyond f in the other direction, with corresponding proportions of image.

614. **To Measure Focal Length.**—The practical application of this method is varied. Say that we want to find out what is the focal length of our lens. We focus an object carefully at actual size; then measure accurately the distance between object and focusing screen and divide by four. The quotient is the focal length of the lens. Thus, if we find that the distance from object to focusing screen is 40 inches, the focus of the lens is 10 inches. On the other hand, if we are to photograph an object actual size, what camera extension is required with a 10 inch focus lens? Object and image are equidistant from the lens, each two focal lengths away; consequently we must have camera extension sufficient to give us a distance of 20 inches from

center of lens to plate. Or we want to know what distance is required between lens and object to give us an image of a certain size. For instance, we want to know at what distance a 12 inch focus lens will give us a 4 inch image of a person 6 feet tall. Size of object is 72 inches, size of image 4 inches; ratio of image to object (scale of image we will call it) therefore is 1-18. Consequently the object must be 18 focal lengths beyond f^1 , and 19 focal lengths beyond the center (c) of the lens—19 times 12 inches, or 19 feet. In the same manner the distance required with a 20 inch focus lens is found to be 19 times 20 inches, or 380 inches, or 31 feet 8 inches.

615. Conversely we want to know the focal length of lens required to give us a 4 inch figure of a person 6 feet tall at a distance of 20 feet. Scale of image, as before, is 1-18, which means that the object must be 18 focal lengths away from f^1 and 19 focal lengths from the center (c) of the lens. In other words, the distance of 20 feet or 240 inches must be equal to 19 times the focus of the lens required, or the focus of the lens must be $1-19$ of 240 inches. Divide 240 by 19; the quotient is 12 $12-19$, and we therefore require a lens of 12 $12-19$ (12 $2-3$) inches focus. If the distance is 15 feet, the 15 feet or 180 inches must be equal to 19 times the focus of the lens. Divide 180 by 19 and the quotient is 9 $9-19$; the required focal length is 9 $9-19$ inches, or just about $9\frac{1}{2}$ inches.

616. Again, what size image will a 10 inch focus lens make of an object 6 feet tall at a distance of 30 feet? Distance, 30 feet or 360 inches equals 36 times the focus of the lens. Distance between f^1 and object is therefore 35 focal lengths; scale of image is 1-35, which means that the size of the image is $1-35$ of 72 inches, or about 2 inches.

617. For group work in a short gallery the choice of lens has often proven both difficult and puzzling. Say that we require a lens for 8x10 groups in a gallery where we can get an operating distance of 18 feet. The width (or length, if we so wish to term it) of the group is of course, limited by the width of the gallery, so that we can without much difficulty determine how wide will be the widest group

which we can arrange there. Let the maximum width of group be 15 feet. On an 8x10 plate we could not very well make it over 9 inches. Size of object then is 15 times 12 inches or 180 inches; size of image 9 inches; scale of image 1-20. Distance from lens to group, 18 feet or 216 inches, must therefore equal 21 focal lengths, or 21 times the focus of the lens required. Dividing 216 by 21, we get the quotient of 10 2-7—and we know that the lens must have a focus of 10 2-7 inches. It then becomes a question of finding a lens which with this focal length combines sufficient covering power and speed for our purpose—that is, one which will cover the plate satisfactorily with a relative opening large enough to give satisfactory speed.

618. **Depth of Focus.**—Depth of focus or depth of definition, in the popular meaning of those terms, is the property possessed by a lens of rendering at the same time sharp images of several objects, situated at different distances from the lens. Strictly speaking, from a purely optical point of view there can be no such thing as depth of focus; for, as was pointed out in connection with conjugate foci, any variation in distance of object means a variation in distance of image; but in practice we find that there is a more or less considerable distance within which we apparently have all the objects sharply defined. We all know that if we focus on an object very far away, everything beyond that is apparently sharp; also that, if we focus on an object a moderate distance away, we have other objects some distance nearer to and farther away from us in apparently good focus, because an image disc appears as a point when its diameter is sufficiently small; therefore when the discs which compose the different images of the different objects are within this limit, the images all appear sharp. The closer together—the more nearly in one plane the different images are, the more nearly they possess the same sharpness. The reason why all objects situated beyond a certain distance appear in equally good focus is therefore apparent. Focus with a 10 inch focus lens an object situated at a distance of 1000 times the focal length

of the lens (about 833 feet). The image will then be located 1-1000 of a focal length behind the principal focus. Any and all objects situated between 833 feet and infinity will have their images all located within that distance of 1-1000 of a focal length, that is, within a distance of 1-100 of an inch. They will be very nearly in the same plane, and the diameter of the disc of confusion in all of them may be so nearly the same as to make them all appear equally sharp. For similar reasons, if we focus an object a moderate distance away, we find that other objects, both nearer and more distant, appear in good focus. Their distances relative to the object focused upon are such as to cause only a slight difference in distance of images; so slight that their disc of confusion is less than 1-100 of an inch in the plane of sharp focus for the object we selected to focus for. If we then select, one after the other, objects situated nearer to us, we find that as the object focused upon is nearer, the distance through which other objects will also appear in good focus is lessened—the depth is less, because there is a greater variation in distance of image and a consequent greater variation in the diameter of the disc of confusion, the nearer the object is to the lens. We can thus see that *the farther the distance focused for, the more depth we have; the nearer that distance, the less depth, with the same lens.*

619. **Influence of Aperture on Depth of Focus.**—Apart from the distance, depth of focus depends on two factors: the aperture of the lens and the focal length of the lens. How the aperture affects the depth needs very little explanation. Every photographer knows that he can increase the depth by decreasing the aperture (stopping down), and that with a larger aperture (stop) the depth is less. The increase or decrease of the depth is proportionate to the decrease or increase of the diameter of the aperture; in other words, *depth of focus varies inversely as the diameter of the aperture.* Fig. 19 illustrates the influence of aperture on depth. The larger pencil (D) tapers to a point rather abruptly, and even a very slight variation in the position of our focusing screen (b) will be apt to give us a disc of more

than 1-100 of an inch diameter, while the gradual tapering of the smaller pencil (d) will allow of a considerable displacement either in front of or behind the plane of greatest

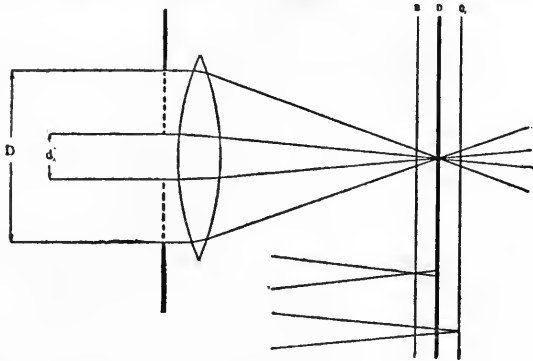

Fig. 19

sharpness. Thus the one object sharply focused at (b) will appear sharp enough at (a) and at (c); and other objects so situated that their images would have their greatest sharpness at (a) or at (c), will also appear sufficiently sharp at (b).

620. Influence of Focal Length on Depth of Focus.—

The influence of focal length on depth of focus is often either not at all understood, or entirely misunderstood. The idea is very prevalent that longer focus means, or should mean, greater depth, while in fact it is just the reverse. The distance between the principal focus and the sharp image being a certain fraction of the focal length, it is plainly evident that the longer the focus, the greater must be the variation in distance of the focal planes for objects situated at different distances from the lens. For instance, two objects situated respectively 50 feet and 100 feet from the lens, will have their images about 1.32 inch apart with a 6 inch focus lens, and about $\frac{1}{8}$ inch apart with a 12 inch focus lens. It is therefore plain that the range of distance—or the space—throughout which different objects may be distributed and yet appear sharp at the same time (in the same plane) is greater, the shorter the focus of the lens is,

and vice versa. In other words, the shorter the focus of the lens, the more depth; the longer the focus, the less depth.

621. With the same relative aperture, *depth varies inversely as the square of the focus.* Thus, of two lenses of the same rapidity (that is, having the same ratio of aperture to focal length) the one having double the focal length of the other will have only one-fourth its depth. Take for example one lens of 2 inches aperture and 6 inches focus, and another one of 4 inches aperture and 12 inches focus. The aperture ratio (ratio of diameter of aperture to focal length—relative aperture) is the same (1-3) in both lenses; therefore, their relative depth is inversely as (6x6) 36 and (12x12) 144, or directly as 144 and 36, or as 4 and 1. Two lenses of respectively 2 inches aperture with 8 inches focus and 3 inches aperture with 12 inches focus, will also have the same relative aperture, and their relative depth will be inversely as 64 and 144, or directly as 9 and 4; that is, the 8 inch focus lens will have fully twice the depth of the 12 inch focus lens.

622. To sum up: Depth varies *inversely as the diameter of the aperture*, and *inversely as the square of the focus*; therefore, 1—*With the same focal length and the same relative aperture in any two or more lenses, the depth is the same*; 2—*With the same focal length but different relative aperture, the depth is inversely proportionate to the diameter of the aperture*; 3—*With the same relative aperture but different focal length, the depth is inversely proportionate to the square of the focus.*

623. **Speed of Lenses—How Determined.**—The term speed, or rapidity, as applied to a photographic lens, refers to the energy or intensity of light action on the sensitive plate. The stronger, or more energetic that action is, the more rapidly it produces the desired effect on the sensitive silver salts, and the greater, we say, is the speed of the lens. It is needless to say that the volume of light here plays an important part. It is quite plain that the greater the volume of light acting on the plate, the more rapidly must

the result be obtained; consequently, the more light the lens transmits to the plate—other conditions being equal—the greater is its speed. The *volume* of light, therefore, is one of the factors which determines the speed of lenses. Another factor is the concentration of the light, or, as we generally term it, its *intensity* when it reaches the plate. Other conditions, such as quality of material, perfection of workmanship, etc., being equal, those two factors determine the relative speed in all lenses, regardless of type or make.

624. The volume of light is regulated by the aperture of the lens—the opening (diaphragm) through which it must pass in order to reach the plate. The larger the area of this opening, the more light it will admit. Thus, if we have two circular openings of different size, it is evident that the larger one will let through more light than the smaller one, in proportion as its area is larger—in other words, the volume of light is directly proportionate to the area of the opening. If we know how much larger in area one opening is than the other, we also know how much more light it admits.

625. From geometry we know that circular areas compare as the squares of their diameters; consequently the volume of light transmitted through the two openings re-

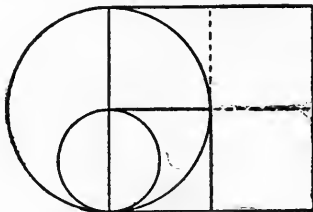

Fig. 20

spectively *must be directly proportionate to the squares of their diameters*. In Fig. 20 we have two circles in which for easier comparison the larger is twice the diameter of the smaller. Inspection shows the square of the larger diameter to be equal to four times that of the smaller. Since the areas of the two circles are proportional to these squares, it follows

that the larger has four times the area of the smaller and consequently transmits four times as much light. If the diameters are one inch and two inches respectively, the proportion of light is as 1×1 and 2×2 , or as 1 and 4. In the same manner diameters of two inches and three inches give us the proportion of light as 2×2 and 3×3 , or as 4 and 9.

626. If the distance between lens and plate is the same, the intensity of the same volume of light is also the same; there is no variation in intensity, and speed depends on the *volume of light* alone. Thus, in one and the same lens, or in several lenses of the same focal length, but different types, when used under the same conditions, *speed is proportionate to the square of the diameter of aperture*. If we have one lens with, say four stops, 1, 2, 3, and 4 inches in diameter respectively, the relative speed of the lens with those stops will be as 1, 4, 9, 16. If we have several lenses, all of the same focal length and with stops as just mentioned, their speed will be the same with the same diameter of stops, and different with different diameter of stops. In short, *with the same focal length and same diameter of aperture in any two or more lenses, their speed is the same; with the same focal length but with different diameter of aperture, the speed is proportionate to the square of the diameter*.

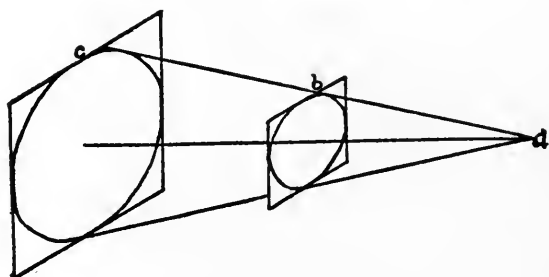

Fig. 21

627. If the focal length—the distance of the plate from the lens—is different, the volume of light alone does not determine the speed, for the *intensity*, or concentration, of the light varies with the distance between lens and plate

(the focal length of the lens). As the light travels farther away from the lens, its intensity is diminished. Fig. 21 will help us understand this. A cone of light emanating from a source (a)—in this case the diaphragm opening in a lens—forms a disc of light of a certain size on a screen placed at (b) and a larger disc on a more distant screen (c). The areas of these discs, as we already know, compare as the squares of their diameters. Their diameters are proportionate to their distances from the source of light; consequently, the areas of the two discs must be proportionate to the squares of those distances.

628. The total amount of light falling on the two screens is the same, but on the more distant screen it is distributed over a larger area, and its concentration, its intensity, is therefore necessarily less. In Fig. 21 the distance of the screen (c) from the source of light is twice the distance of the screen (b). Area being proportionate to square of distance, the area of the larger disc is consequently four times the area of the smaller one. Each corresponding part (each one-fourth) of the larger disc can therefore only receive one-fourth of the total amount of light, and the intensity can be only one-fourth of the total intensity. Thus we find that the intensity of the light is inversely proportionate to the area—the smaller the area covered by the same quantity of light, the greater is the intensity, and vice versa. As the area is proportionate to the square of the distance, and as the distance here means the focal length of the lens, we conclude that *the intensity of the light—and the speed of the lens* in so far as it depends on that intensity—*is inversely proportionate to the square of the focus.*

629. If the volume of light remains constant, variation in speed is determined by variation in focal length only. In two or more lenses of the same aperture, the volume of light transmitted is the same, and speed is inversely proportionate to square of focus. The speed of a 3 inch and a 6 inch focus lens of the same aperture will compare inversely as 9 and 36, that is, directly as 36 and 9; in

other words, the 3 inch focus lens will be four times as quick as the 6 inch focus lens.

630. So far we have presumed that when one of the factors, either the diameter of aperture or the focal length, varied, the other remained constant, and the variation of the one factor alone then governed the variation of speed. We should bear in mind, however, that with a variation in distance of the object there is also a corresponding variation in distance between lens and plate, with a consequent variation in intensity of light, even though the aperture remains constant. This variation is of little importance when the lens is used at or near its equivalent focal distance from the plate, as for general landscape work, for reasons which we understand from what was pointed out in connection with conjugate foci. But when we photograph near-by objects requiring the plate at a greater distance than the equivalent focus, the variation requires consideration. Using a 12 inch focus lens, take a distant landscape requiring the plate at the equivalent focal distance, and a near object requiring a distance of 15 inches between lens and plate. With the same aperture giving the same volume of light, the intensity of the light—the speed of the lens—would be vastly different in the two instances. Being in inverse proportion to square of distance, it would be inversely as 12×12 and 15×15 , that is, as 15×15 and 12×12 , or as 225 and 144, or as 25 and 16. Exposure time being in inverse proportion to intensity and speed, it would be directly proportionate to square of distance between lens and plate, that is, as 12×12 and 15×15 , or as 16 and 25. The near object would therefore require fully one-half again the exposure required for the landscape.

631. In our previous comparison of the speed of two or more lenses we considered only the variation of one factor at a time, assuming the other factor, either the aperture or the focal length, to be the same in both or all of them. If both aperture and focal length are different, the problem of determining the relative speed becomes somewhat less simple. We consider the variation in volume and intensity

of light together—in connection with each other—instead of separately. A certain diaphragm opening admits a certain volume of light. With any variation in diameter of this opening, the volume of light varies directly as the square of the diameter. The light possesses a certain intensity at the diaphragm opening. This intensity is gradually diminished, and the diminution is proportionate to the square of the distance traveled. As the relative speed ultimately depends on the relative intensity of light action on the plate, and as we cannot directly compare volume and intensity—quantity and quality—it becomes necessary to have volume represented by intensity, or to estimate the relative intensity of different volumes of the same light at the same point. A certain volume of light represents a certain amount of intensity—initial intensity we may term it—at the point where that volume is estimated. An increase in volume of the same light quite naturally means a corresponding increase in the amount of intensity and vice versa. The initial intensity therefore varies as the volume of light varies, or as the square of the diameter of aperture. As this intensity is diminished in proportion to the square of the distance, we can without further preliminaries conclude that the ratio of the square of aperture to square of focus denotes the relative ultimate intensity, the relative speed.

632. For example let us take two lenses of respectively 2 and 4 inches diameter and 6 and 12 inches focus. Their relative initial intensity as based on relative volume of light is as 2×2 and 4×4 , or as 4 and 16. The intensity is diminished in proportion to the square of the focus, or as 36 and 144. Therefore, the relative ultimate intensity, or relative speed, must be as $4-36$ and $16-144$, or as $1-9$ and $1-9$; that is, the two lenses have exactly the same speed with those apertures. The fraction denoting the relative ultimate intensity is termed the intensity ratio, or ratio of intensity, and when that is the same for any two or more lenses, their speed is the same.

633. We can analyze this example independently of those figures. The 12 inch focus lens has twice the diameter

of the 6 inch focus lens and consequently transmits four times as much light; but the four times larger volume, after traveling twice the distance, is distributed over a four times larger area, and the ultimate intensity is therefore the same with both lenses.

634. Further analysis shows that the diameter of aperture bears the same relation to focus in both of them—or, as we generally term it, *both lenses have the same relative aperture*. The ratio of 2 to 6 is as 1 to 3, or 1-3, and the ratio of 4 to 12 is as 1 to 3, or 1-3; that is, the diameter is in both instances equal to one-third of the focal length of the lens—the aperture ratio (the ratio of diameter of aperture to focal length) is 1-3.

635. *The intensity ratio, as we can plainly see, is the square of the aperture ratio.*

We therefore conclude that

I.—Speed depends on the aperture ratio, or relative aperture.

II.—Speed is proportionate to the square of the aperture ratio.

III.—The same aperture ratio, or relative aperture, means the same speed.

636. Thus, if we know the ratio of the diameter of aperture to focal length, regardless of their actual measurements, it is an easy and simple matter to calculate the relative speed.

637. Various systems have been devised to express and mark the relative value of certain openings. Of these systems we shall concern ourselves with two only, the *focal ratio system* and the *uniform system*.

638. The focal ratio system is so called, because it is based directly on the ratio of aperture to focus. *The diameter of the aperture is represented as a fraction of the focal length* (the fractional diameter)— $f/2$, $f/3$, $f/4$, $f/8$, etc., meaning that the diameter of the aperture is 1-2, 1-3, 1-4, 1-8, etc., of the focal length of the lens, or that the aperture ratio is 1-2, 1-3, 1-4, 1-8, etc. The intensity ratio, or relative intensity, relative speed, as we have previously seen,

is the square of the aperture ratio, or, 1-4, 1-9, 1-16, 1-64, etc. Exposure time being in inverse proportion to speed, relative exposure must be as 4, 9, 16, 64, etc.

639. Thus the fractional diameter gives directly, or indirectly, aperture ratio (relative aperture), relative speed and relative exposure. The ratio number, 2, 3, 4, 8, etc., as denominator, with one as numerator, gives the aperture ratio; and the square of the aperture ratio gives the relative intensity or relative speed—and inversely the relative exposure. The following table will help make this clear:

Fractional diameter	$f/2$	$f/3$	$f/4$	$f/8$,	etc.
Aperture ratio . . .	$\frac{1}{2}$,	$\frac{1}{3}$,	$\frac{1}{4}$,	$\frac{1}{8}$,	etc.
Intensity ratio, or } Relative intensity }	$\frac{1}{4}$,	$\frac{1}{9}$,	$\frac{1}{16}$,	$\frac{1}{64}$,	etc.
Relative exposure..	4	9	16	64	etc.

640. The intensity, or speed, being in direct proportion to the square of the aperture ratio, the speed value of any two openings can thus be easily compared. The speed of $f/2$ and $f/4$ for instance, is proportionate to 1-4 and 1-16 respectively. But *these fractions compare inversely as their denominators*, and the denominators are the squares of the ratio numbers; consequently the *speed is in inverse proportion to the squares of the ratio numbers*. Thus the speed of $f/2$ compares with the speed of $f/4$ inversely as the square of 2 compares with the square of 4, that is, inversely as 4 and 16, or directly as 16 and 4, or as 4 and 1.

641. Exposure time being in inverse proportion to speed (the more speed, the less exposure, and vice versa), it follows that *exposures are directly as the squares of the ratio numbers*.

642. It is needless to say that *the same ratio number means the same relative aperture*, and consequently *the same speed and the same exposure time* with all lenses.

643. Depth of focus being in inverse proportion to diameter of aperture and therefore directly proportionate to the ratio number, it follows that, I—*With the same lens, or with several lenses of the same focal length, depth of focus with*

the various apertures is directly proportionate to the ratio numbers; II—With the same ratio number (relative aperture) and the same focal length, depth of focus as well as speed is the same.

644. The apertures which are marked have been so chosen that each succeeding smaller one has one-half the area of the preceding larger one and consequently requires double the exposure.

645. Beginning with $f/1$, an aperture the diameter of which is equal to the focal length of the lens, the series of apertures will be as follows:

$f/1, f/1.41, f/2, f/2.83, f/4, f/5.6, f/8, f/11.3, f/16, f/22.6, f/32, f/45.25, f/64, f/90.5$.

646. **The Uniform System** (U. S.) is based on the focal ratio system as shown in the following table, and the aperture numbers give directly the relative exposures:

Relative Aperture	$f/4$	$f/5.6$	$f/8$	$f/11.3$	$f/16$	$f/22.6$	$f/32$
U. S. No.	1	2	4	8	16	32	64
	$f/45.25$	$f/64$	$f/90.5$				
U. S. No.	128	256	512				

647. An aperture of $f/4$ is here taken as requiring a unit exposure and is marked 1. The next smaller opening, $f/5.6$, requiring double the exposure of $f/4$, is marked 2; the next one, $f/8$, requiring double the exposure of $f/5.6$ and four times the exposure of $f/4$, is marked 4, and so on. The numbers 1, 2, 4, etc., thus have reference only to the comparative exposures, and the exposures read directly as those numbers. If No. 1 requires 1 second, No. 16 requires 16 seconds. If No. 8 requires 3 seconds, No. 32 requires 12 seconds. If No. 128 requires 2 seconds, No. 16 requires $\frac{1}{4}$ second, and so on.

648. **Superiority of Anastigmat Lenses.**—From what has already been said in explanation of spherical aberration, astigmatism, curvature and flatness of field, covering power and definition, the value of an anastigmat over an ordinary R. R. lens is sufficiently clear to require very little further explanation. Its superior correction for spherical aberra-

tion and astigmatism not only results in more perfect definition per se, but this definition extends over a larger part of the field with more perfect evenness. Its flatness of field and larger area of critical and even definition combined, give it a covering power vastly greater than that of the R. R. lens. With the same focal length, the anastigmat is therefore capable of giving, with the same or larger relative opening, more perfect and even definition over a considerably larger area. In addition to this, it gives more even illumination over a larger area, and its superior marginal correction extends its covering power close to the edge of the field, when the aperture is reduced.

CHAPTER XXXIV.

WHY AN ANASTIGMAT IS DESIRABLE.

649. There are a great many photographers who possess, or who look forward to one day possessing, an anastigmat lens, who may not fully understand the special advantages of such an instrument. Thoughtful workers, however, may pause to ponder over the matter, and it is this class of worker that will benefit, to the greatest extent, by the following:

650. **Not Always Desirable.**—The modern lens is not always the most suitable instrument to use for all work. There are some subjects more pleasingly rendered with the blending of definition and diffusion, both of which qualities are characteristic of the spectacle lens or the single landscape lenses which have recently been introduced by the leading manufacturers.

651. **Purely a Matter of Speed.**—The anastigmat is superior in point of speed, that is all. Take two lenses of 6 inches focal length—one of them an anastigmat, the other a rapid rectilinear. Select an ordinary landscape, with nothing nearer than 50 feet, and expose one plate with the anastigmat working at its full aperture—say, F. 6.3; then, changing the lens, expose the second plate, using the rectilinear at, say, stop F. 22, giving, of course, the proportionate exposure, approximately twelve times as long. On development of the two plates the negatives will appear the same, the one taken with the rectilinear lens being as crisp right up to the edges as the one produced by the anastigmat. We arrive, therefore, at this conclusion: That if we are working on subjects admitting of lengthy exposures, supporting the camera on a tripod and indifferent as to whether the wait while exposing on dark subjects is long or short; such as

interiors, the rectilinear (and cheaper form of lens) will answer requirements. The anastigmat gives nothing more than the stopped down rectilinear, but it permits the same result (in this instance) in one-twelfth of the time.

652. The Difference in Definition.—A further experiment may be made by exposing two more plates on the same landscape, using the two lenses at the same aperture and giving equal exposures. As in all likelihood the largest stop on the rectilinear lens is F. 8, this must be employed, stopping the anastigmat to the same aperture. After development of the negatives make a careful comparison of the definition, and you will find that although the center of the negative made with the rectilinear lens will be very sharp, the margins will be less so. This will be particularly noticeable if such subjects as leafless twigs of trees come near the edges of the picture. We have already dismissed those cases where this blurring or softening of definition is wished for, and are assuming that sharp definition all over the plate is required.

653. Let us now consider why the anastigmat lens gives proper rendering of sharpness, while the rectilinear lens fails to accomplish this result unless its aperture is considerably reduced.

654. Why the Margins are not Sharp.—As we have previously indicated, the two defects in the rectilinear lens which render the marginal definition imperfect are *astigmatism* and *curvature of field*. *Astigmatism* is an error existing in oblique rays of light, and so effects, to any noticeable extent, the margins only. To study it you may fix against the window a large sheet of thin cardboard or stout black paper—ordinary brown paper has too many holes in it for this purpose. Now make a pin-hole with a good size pin, as smoothly as possible. Place the camera about a yard from the sheet of cardboard, and, using the rectilinear lens, focus the pin-hole sharply on the center of the ground-glass. Then rotate the camera until the image falls on the margin of the ground-glass, and rocking it backwards and forwards you will find that instead of a sharp image you secure, first,

a long narrow ellipse—almost a line in fact—running vertically; next, a circular blur, and then a long ellipse, this time running horizontally.

655. Now turn the camera around, take down the sheet of thin card, and fix up, about a yard away from the lens, in a good light, a white card, on which you have drawn, in good black ink, a plain cross like the $+$ sign. The arms may be about an inch long, and should be as thick as an ordinary stroke of a pin. Regard this cross as consisting of a great number of points like the original pin-hole. With the screen in the first position each point is represented as the long ellipse running vertically. The upright arm of the cross is thus clearly defined, because the many ellipses overlap each other, but the horizontal arm is represented by multitudes of ellipses arranged side by side instead of end to end, and is thus blurred. If the lines of the cross are very fine, it is possible that one arm may disappear entirely on the ground-glass image.

656. Moving the screen to the second position we get both arms equally blurred, and still further in the third position the ellipses running in horizontal directions give us an image with the horizontal arm sharply defined and the vertical arm blurred and almost invisible. Obviously, what happens in the case of the cross, happens to the tree twigs in your landscape with lines and architecture, and so on with all other subjects.

657. **Curvature of Field.**—A further reason for the blurring of the margins is found in the fact that the image formed by the rapid rectilinear lens is not on a flat plane, but is hollow like a saucer—the field is said to be curved. The optician can eliminate astigmatism, but as he does the field becomes more curved. He can also flatten the field, but to do so increases the astigmatic error. Aided by the comparatively new Jena glasses he can construct a lens which has both a flat field and freedom from astigmatism. These glasses are more costly, and the degree of accuracy in polishing their surfaces needs to be greater if errors are

to be satisfactorily eliminated, hence the greater the cost of the modern lens.

658. The use of a smaller stop, as you have seen, diminishes, to a certain degree both these errors, but at the same time lessens the tendency of rapidity in the lens.

659. **Size of a Lens.**—Some beginners think because a certain lens includes more of a subject on the plate than others that a larger and more bulky instrument must be employed. A student once expressed himself that he could not use a wide-angle lens on his camera, as the regular lens he had was so large he could hardly get it on the front board; and as he knew the wide-angle lens would take in more of the subject, he thought it must, of necessity, be a larger and bulkier lens.

660. **What is Covering Power?**—The lens as ordinarily fixed to a camera produces an image sufficiently large to cover the whole of the plate, or ground-glass. That is, the purchaser of a cheap $3\frac{1}{4} \times 4\frac{1}{4}$ camera, on focusing a view, finds that the picture extends to the corners of the ground-glass focusing screen. Under normal circumstances then the covering power of the lens is sufficient. Suppose, however, that you take this lens off and attach it to a 12×15 camera. An enlarging camera will do if you cannot borrow a landscape camera from a friend for the experiment. The front of the camera will, of course, be only about 5 inches from the ground-glass when the picture is sharp, and you will find the image you get is circular, being about 7 or 8 inches in diameter. At the edges of the focusing screen you will secure no image at all, and, therefore, no light.

661. Now you have some indication of the covering power of the particular lens you are experimenting with. It will cover a $3\frac{1}{4} \times 4\frac{1}{4}$ plate, but not a 12×15 . If you will carefully examine the disk, or round image, on the large focusing screen, you will find the definition is much better in the center than at the edges. You will also notice that the image is brighter in the center than at the edges. The definition falls off towards the edges of the image, because the lens is not corrected for astigmatism and curva-

ture of field. If you will stop it down to F. 16 or F. 22, a reasonable amount of sharpness of definition will be produced up to the edges of the image. But, the stopping down will not increase the size of the disk, or, in other words, the circle of illumination. You will also find upon carefully examining the brightness at the center and on the edges of the disk, that much greater equality exists. Why is this?

662. **Equality of Illumination.**—Open the lens to the full aperture, for instance F. 8, and removing the ground-glass place your eye—one eye only, closing the other—opposite the lens. You will observe from this position that the full aperture appears as a circle. Now move the eye slowly towards one corner of the camera back and notice what change takes place in the apparent shape of the lens aperture. The circular shape gradually changes to an ellipse, which soon, owing to the ends of the lens barrel interfering, becomes narrower and more elongated, until before the eye reaches the corner of the camera back no direct light can be seen at all. The quantity of light received by any portion of the plate is, of course, proportional to the size of aperture as seen from that portion. When the eye can see no direct light, you have reached that part of the plate onto which the lens projects no image. Now repeat this operation when the lens is stopped down to F. 22, and it will be found that the eye can be moved a considerable distance from the center towards the corner before any part of the small circle of light seen through the F. 22 aperture is obstructed by the mount.

663. **Wide-Angle Lens.**—It should now appear quite clear to you that if a lens is to have great covering power its barrel must be short. In other words, the two glasses, the front and back combinations, must be mounted close together. If you compare an ordinary—especially an old pattern—rapid rectilinear lens with a wide-angle rectilinear, you will find this is what the optician does. The close mount tends to increase the curvature of field, however, and in order to prevent the photographer using the lens at too large an aperture and then condemning it for poor marginal

definition, the stop F. 16 is usually the largest one provided. Most of the modern anastigmats have their combinations mounted close together in a short barrel, consequently have great covering power; but as with them both astigmatism and curvature of field are practically eliminated, the larger aperture of F. 8, or even F. 6, is available.

664. **What Plate Will the Lens Cover?**—Going back to the $3\frac{1}{4} \times 4\frac{1}{4}$ lens you may measure the diameter of the circle of illumination on the ground-glass of the 12 x 15 camera. Supposing this to be 8 inches, draw a circle of this diameter on a sheet of paper. The lens will then cover any plate that can be laid inside this circle. A 5 x 7 plate will extend beyond it at each corner, so the lens will not cover a 5 x 7 plate. The 4 x 5 plate will go inside the circle, as will a $3\frac{1}{4} \times 4\frac{1}{4}$ plate, the lens covering either of these sizes easily. Now, raise the front of the 12 x 14 camera and note that the circle of illumination on the ground-glass is raised at the same time. It will be quite evident, then, that there must be an excess of covering power so that you can adjust the image on the plate, the position of which in your camera is fixed by raising or lowering the front carrying the lens. In cases where none of this excess or reserve of covering power exists, raising the lens frequently produces dark corners in the sky of the picture.

665. **The Focal Length.**—With the older types of lenses the focal length had much to do with relation to covering power, and it is with this type of lens that the focal length must be not less than the diagonal of the plate. If shorter than this (about 5 inches for $3\frac{1}{4} \times 4\frac{1}{4}$ plate, 6 inches for 4 x 5 plate, and 9 inches for a 5 x 7 plate), there will be insufficient covering power, and shorter foci lenses of the wide angle type are necessary. With modern lenses, however, there is, as has already been said, a reserve of covering power. The lens may be chosen of a suitable focal length with reasonable certainty of covering the plate. Thus a 5 inch anastigmat, which may be the normal lens, with $3\frac{1}{4} \times 4\frac{1}{4}$ camera, can be used on a 5 x 7 plate with confidence. This could not be done in the case of the rapid

rectilinear. An approximate rule for determining the foci to be used on any size plate is, for a *wide angle*, the shorter dimension of the plate; for a *normal angle*, the diagonal, and for a *narrow angle* or *long focus lens*, the length and width of the plate added together. In the case of a 5 x 7 plate the three lengths would be approximately 5 inches, 8½ inches and 12 inches focus, respectively.

666. **Schriever Universal Extra Rapid Lens, Speed F/6.**—The production of this new lens is the result of a pressing demand for a lens that would perform the highest grade of service in all the departments of photography.

667. The Schriever Universal fulfills alike the requirements of the studio, the commercial and landscape photographer, and can also be highly recommended for copying and hand camera work.

668. With it instantaneous pictures can be made on dark and misty days where slower lenses would utterly fail. The 4 x 5 and 5 x 7 sizes readily adjust to hand cameras. The larger sizes are highly recommended for studio portraiture and group work. With the 8 x 10 size, a full length cabinet picture can be made in a fifteen foot operating room. Their speed, depth of focus, compactness and high grade general utility at the moderate prices at which they are quoted, give them much prestige in the photographic world.

669. Owing to the fact that the front and back combinations of this lens are individually corrected, the operator may, by the use of the back combination alone, produce an image of twice the size of one obtained with the entire objective, and also increase the focal length of same to double that of the whole lens. These lenses are supplied fitted with Iris diaphragm. They are also furnished fitted complete with Unicum shutter. When equipped with shutter the Iris diaphragm is included in the shutter.

CHAPTER XXXV.

STOPS OR DIAPHRAGMS.

670. The opening in a lens is its aperture. Anything that will give various sizes of openings for the admission of light may be termed a stop or diaphragm.

671. Stops and diaphragms, while used in the same manner, are differently located. A *stop* is placed in front of the lens, and a *diaphragm* is placed between the lenses. The former is almost always used with single lenses, while the latter is employed with doublets. For general use there are three forms: The iris, waterhouse and rotating stops or diaphragms.

672. There are three distinct uses to which stops may be put. Unless the photographer realizes this and forms some idea of the way in which each purpose is achieved by the use of stop or diaphragm, he will be working in the dark and not secure the results which might have been easily produced if proper consideration had been given to this subject.

673. **The Three Uses of Stops.**—The first distinct purpose to which the stop is put is to overcome the optical defects of the lens should there be any; second, it is to bring objects located at various distances from the camera into sharp focus at the same time, and third to accent the shadows or give more contrast in flat scenes.

674. **Comparative Sizes.**—In order that it may be an easy matter to figure the required amount of exposure for any particular stop, when the exposure is given for another stop, it is necessary to have a system of numbering the different sizes. In common use there are two such systems, one known as the *f*, or focal length system, the other U. S., or uniform system. The *f* system is a comparison between

the focal length of the lens and the diameter of the stop, while the U. S. system is simply a comparison of the exposure values of the different size stops.

675. To Find the Focal Value of a Stop.—To find the focal value of a stop or diaphragm, first ascertain the equivalent focus of the lens, and divide this by the diameter of the stop. Example: If the focal length of the lens is 8 inches, and the diameter of the stop is $\frac{1}{4}$ inch, the result of 8 divided by $\frac{1}{4}$ is 32. The number of the diaphragm is, therefore, 32, and should be expressed $f/32$.

676. Systems Compared.—In the U. S. system No. 1 is $\frac{1}{4}$ the focal length of the lens, which is written in the f system, $f/4$. The diameter of No. 2 must be such that the area of the opening will be half that of No. 1.

677. To Secure the f Value.—To secure the equivalent value of U. S. 2 in the f system, square the f value of U. S. No. 1, which is 4 (this will give 16); then multiply by 2 (result 32), and finally extract the square root, which will give a result of 5.6. Therefore, $f/5.6$, is equivalent to U. S. 2.

678. First, the volume of light that passes through the diaphragm is proportionate to the area of the aperture. Second, the areas of circles are proportionate to the square of their diameters. By working out the remainder of the figures the complete series will be as follows:

U. S.	1	2	4	8	16	32	64	128	256
	$f/4$	5.6	8	11.3	16	22.6	32	45	64

679. Comparative Exposures.—With lenses numbered this way, and the exposure is given for any one diaphragm, the exposure for any other diaphragm may be easily ascertained. The exposure for a certain stop is one-half that of the size next larger, or double that of the next smaller. Example: U. S. 4 or $f/8$ will require twice the exposure of U. S. 2 or $f/5.6$, and on the other hand, it will need but one-half the exposure necessary if stop U. S. 8 or $f/11.3$ were employed.

680. To Find the U. S. Number When Number is Given for the f System.—When the diaphragm number is given

for the *f* system, and it is desired to find its equivalent value in the U. S. system, square the *f* value and divide by 16. Example: To find the U. S. number of the diaphragm which may be marked *f*/20, square the 20, which will give 400. Divide this by 16, and the answer will be 25, which is the U. S. number.

681. **How to Find the Relative Exposure.**—There may be times when you desire to find the exposure of two different stops, which are not given in the regular scale, and, therefore, you will be unable to find the correct relative exposure. Take, for an example, stop *f*/7 and stop *f*/8. The relative exposure is found by multiplying each of these numbers by themselves, and then taking the proportion: $7 \times 7 = 49$, and $8 \times 8 = 64$. $49 \div 64 = \frac{3}{4}$; therefore, *f*/7 requires three-fourths the exposure of *f*/8.

682. **The Larger the Stop the Better the Lens.**—It is a mistake to suppose that with any lens made by a good manufacturer, a subject can be sharply focused in all portions with the largest stop; it depends not only on the workmanship, but also upon the design. A simple form of single lens may have to be stopped down to *f*/22 to obtain a result as good as may be secured with a rapid rectilinear at *f*/16, or one of the finest modern anastigmats at *f*/6 or *f*/8. The largest stop in a rectilinear lens is provided for use when diffusion all over the plate is not so important as rapidity, or when the subject is one which favors the lens. To a great extent this subject has been covered in preceding chapters, and it is, therefore, not necessary to go into detail here regarding these differences.

683. **Subjects Situated at Various Distances Rendered Sharp at the Same Time.**—No matter how perfect the lens may be it is impossible, when using the largest stop, to secure a sharp image of objects situated close by and far away at the same time. The larger the lens the more marked is its failing in this respect. The better or more costly and skillfully designed and made the lens the more is this noticed, because its definition in part is such that where the image is out of focus this blurring is made all the more con-

spicuous by contrast. It is this failing which makes hand camera work increase in difficulty with the larger size plate employed.

684. Let us suppose two photographers are standing side by side, each with a camera with an equally good lens, each using the same stop, and each photographing the same subject. The one using a $3\frac{1}{4} \times 4\frac{1}{4}$ camera and a 5 inch lens may get every detail near and distant as sharp as can be desired; the other, with the 5 x 7 camera and a 7 or 8 inch lens, will be unable to get foreground and distance sharp at the same time, and must stop down in order to do so. This is quite distinct from any stopping down done to remedy defects of the lens.

685. **A Trial May be Quite Valueless.**—Unless the photographer knows how much he has stopped down on account of the difference of distances in the subjects, and how much too great the optical defects of the lens, if any, he is not in a position to say definitely whether his lens is a good one or not. From this it follows that to try a lens on an ordinary outdoor subject, where there may be objects at all sorts of distances from the camera, as so many workers do, can be little or no test of the lens. In practice, of course, when you stop down on account of deficiencies in the lens, you also, at the same time, render it better able to deal with different distances in the subjects.

686. **“What Stop Shall I Use?”**—Few questions are more often asked of the photographer by beginners than the simple one “what stop ought I to use?” The mere putting of such a question is evident that the inquirer has no clear idea of what the stop is supposed to do. No doubt he thinks that if he uses the wrong size of stop his picture will be wrong, though in what way he does not know. It is like a certain amateur, who abstained from attempting anything but portrait work for a long time because he only had a portrait lens. Afterwards he found that it was one which would make excellent landscapes, as well as commercial pictures, when used with a fairly small stop, and that its principal drawback for such work was its bulk or size.

687. There is, of course, no definite rule designating the stop to use for different classes of subjects. For *portraits* the full opening should be used as near as possible, because it is necessary to reduce the length of the exposure. *Landscape Photography* does not make such demands upon the photographic worker. Good, fair definition is all that is required. With *architecture*, definition all over is important, and a small stop must be used, but with *interiors* the largest stop that will give clear definition is necessary to keep exposures reasonably short.

688. "**The Largest Stop.**"—Perhaps it is best to summarize the whole subject by saying that the largest stop that will give the degree of definition required should in all cases be employed, except when you deliberately stop down to accent shadows.

CHAPTER XXXVI.

PHOTOGRAPHIC SHUTTERS.

689. A shutter is a mechanical device so arranged that it protects the sensitive plate from the rays of light entering through the lens, but is capable of being opened and closed at the will of the operator, thus allowing the rays of light to act upon the sensitive plate for as long or as short a time as the photographer desires.

690. There are a great many of these mechanical arrangements constructed in a very great variety of forms. They may be divided into the following classes:

- (1) The drop shutter.
- (2) Between-the-lens shutter.
- (3) The focal plane shutter.
- (4) Behind-the-lens shutter.

691. **The simple drop shutter** when properly constructed is capable of giving very rapid exposures. It is usually a plate of wood, metal or ebonite, which falls by gravitation in front of the lens. The center of the falling piece has an aperture of a certain length, usually two or three times the diameter of the lens. Its rapidity can, of course, be increased by means of an elastic band or string.

692. **The between-the-lens shutter** is composed of a great many varieties, styles and makes, some of the more simple of which we have described in Volume I., for instance, the Wollensak Regular and Automatic Shutters. As the principles of these have been very clearly defined, it is not necessary to go into further detail in this volume regarding them, further than to say that the *regular* shutter has to be set before each exposure is effected, while the *automatic* shutter sets itself after each exposure, so by

merely pressing the bulb or moving a lever another exposure can be effected. The speed of the shutter is regulated by the position of a milled disc, on which is an indicator. To set the shutter for the desired exposure the disc is revolved until the indicator is opposite the proper figures on the dial. The *regular* is made in six sizes, and is one of the best types for general use on hand cameras. It is easy of adjustment, and even in the largest size releases smoothly and without vibration. This type of shutter consists of hard rubber leaves, working between the cells of doublet lenses, or in front of single lenses, their movement being controlled by small levers and springs.

693. The same principle of the above mentioned Iris diaphragm shutters is carried out in the Goerz X L Sector Shutter (See Illustration No. 49), and B. & L. Volute Shutter (See Illustration No. 50), both of which are much more efficient than the Wollensak, and their greater cost is due to the fact that their mechanical parts are of higher efficiency. In addition to this the "Sector" and the "Volute" give practically accurate speeds up to $1/150$ of a second, while the Wollensak Shutters will not give speeds shorter than $1/100$ of a second.

694. **Pneumatic Release.**—The pneumatic release consists of a rubber tube attached to a piston, at the other end of which is a hollow rubber bulb or ball. Pressure upon this bulb will cause the air in the tube to be forced through it, causing the piston rod to set the shutter free. In this way the camera is not moved during the exposure, and the operator can be at any distance from it. If the tube is long enough, it is possible to photograph oneself or be included in the group which he is taking.

695. **Focal Plane Shutter.**—The focal plane shutter is one which is placed directly in front of the sensitive plate, and is composed of an opaque cloth curtain or blind, each end of which is mounted on a spring-actuated spool, or roller. The simplest form of the focal plane shutter has one slit cut in its center, which can be made narrow or wide, according to the desires of the operator, while another

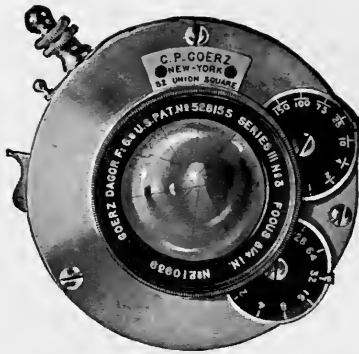

Illustration No. 49
Goerz XL Sector Shutter
See Paragraph No. 693

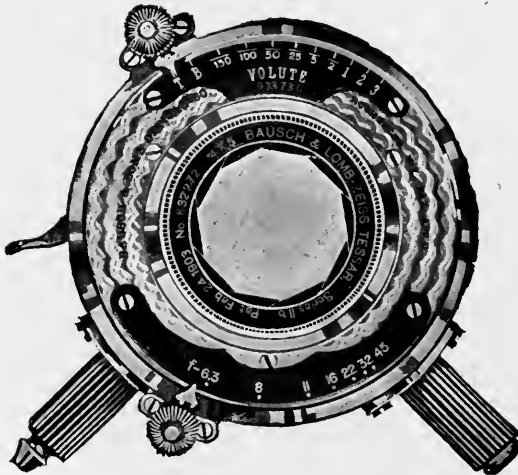

Illustration No. 50
"B. & L." Volute Shutter
See Paragraph No. 693



Illustration No. 51
Photographs made with Multi-speed Shutter on a 3A Kodak
See Paragraph No. 705

form has a series of fixed openings or slits of different sizes. The curtain is wound on one spool and when the spring is released it instantly winds on the other, by which operation the slit or opening is drawn across the surface of the sensitive plate, allowing the light passing through the lens to act upon the sensitive plate. (See Ills. 51*a* to 51*d*.)

696. The amount of speed, or amount of exposure given the sensitive plate depends entirely upon the tension or power of the spring, and upon the width of the opening or slit in the curtain. The narrower the slit and the greater the tension of the spring, the more rapid is the exposure. The focal plane shutter forms part of the camera body, and opens or uncovers the plate or film, having nothing whatever to do with the lens. Therefore, focal plane shutters may also be termed plane shutters.

697. All of the modern reflex cameras are fitted with focal plane shutters, these being built in the cameras. It is possible, however, to purchase focal plane shutters and fit them to the rear of most view or hand cameras. The shutter consists principally of the rectangular wooden frame, having the spring-actuated rollers at top and bottom.

698. The focal plane shutter, working as it does directly in front of the sensitive plate instead of between the lens (thus being considerable distance from the plate), admits fully two times as much light, speed for speed, as any other kind of shutter, with the exception of the Multi-speed Shutter (described later). Consequently, if with the fast between-the-lens shutter full exposure is obtained with say 1-50 of a second, then with the focal plane shutter, same opening and same lens, the plate will get a similar exposure at 1-100 of a second.

699. When employing a shutter between the lens the entire aperture must be open for some parts of the time of exposure, and the longer it is open, in relation to the time of opening and closing, the better. The focal plane shutter need not expose the whole area of the plate at the same instant, but the opening in the curtain of the shutter may

be narrowed down to a mere slit, and if this slit is passed across the plate at a moderate speed the duration of the exposure will be very short.

700. **Efficiency.**—When using this word in connection with an instantaneous shutter, it is understood to mean the relation between the light passed and the total time from the shutter beginning to open and ceasing to close. Every part of a lens acts as a lens, and as soon as a shutter on a lens has begun to open the uncovered part of the lens projects the image on the plate. The brightness increases until the lens is entirely open, and then decreases until the shutter on closing cuts off all light, but any movement in the object will be recorded whether the lens is partly or fully open, so that the time from the first opening to the final closing of the shutter is determined by the rate of movement of the object being photographed, if it is desired to secure a perfectly sharp image. Should the time of a certain exposure be 1-100 of a second, the loss of light the plate sustains on account of the opening and closing amounts to 50 per cent. Thus the efficiency of the average between-the-lens shutter is low.

701. The efficiency of the focal plane shutter is double that of a lens shutter, because the image is formed on the blind of the shutter, the lens being fully open, and the image is just waiting, as it were, to pass through the slit and impress itself on the plate. So far as light action on the plate goes, the focal plane shutter set at 1-100 of a second would give double the exposure of a lens shutter set at the same speed. This is of immense advantage when working at high speeds, or in a dull light on moving objects.

702. **Accuracy.**—Many of the cheaper lens shutters are notoriously inaccurate; the speed marked 1-25 of a second may actually be 1-10 of a second, while that marked 1-50 of a second may be 1-60. With a focal plane shutter the spring may be left alone and the width of the slit changed to produce variations of exposure. Thus, if at a certain spring tension, with a slit 2 inches wide, you secure an

exposure of 1-50 of a second, it is obvious that with the same tension and a one inch slit the length of exposure will be exactly half.

703. **Safety.**—The focal plane shutter affords a protection to the plate, in that the blind is close to the sensitive plate and any trace of stray light entering the camera, no matter whether through the diaphragm or through pin-holes in the bellows, or cracks in the camera box, is kept from producing fog. The blind or curtain should be frequently examined for pin-holes, and if a plate is to be kept in readiness for an exposure for any length of time, it is well to place a cap on the lens.

704. **Distortion.**—This disadvantage theoretically exists with the focal plane shutter, any moving object being distorted to a certain extent. In the majority of cases, however, this distortion is not perceptible to the naked eye or to the casual observer. Distortion is greatest when using a narrow slit and slow movement of the blind; i. e., weak tension of the spring. In practice, therefore, the wiser course is to use a fairly strong tension and to keep the slit as wide as necessary to give the calculated exposure. From an examination of many focal plane exposures you will observe that the distortion is only apparent in cases where an object containing straight lines was moving rapidly. For instance, the funnel of an express locomotive.

705. **Multi-Speed Shutter.**—A new form of between-the-lens shutter has been recently placed on the market, which gives the photographic worker one of the very highest types of shutter obtainable. Owing to its mechanical construction and to the form of the leaves of the shutter, this instrument will give the very best of results working between-the-lens and doing the fastest work for which the focal plane shutter has heretofore been absolutely necessary. In addition to this the manufacturers claim that on the highest speed this shutter gives three times as much illumination as the focal plane shutter, allowing speeds of 1-2000 of a second even with the largest size shutters. This

shutter is known as the Multi-speed Shutter. Photographs made with it are reproduced in Illustration No. 51.

706. The range of speed for the fast exposures is from 1-200 of a second to 1-1000 of a second. For the slow instantaneous exposures the range is from one second to 1-200 of a second. The slow instantaneous *studio* exposures can be regulated from 1 to 6 seconds, as required by the operator.

707. The peculiar instantaneous movements of the shutter blades increase the definition of the lens over 100 per cent. This is due to the fact that it is absolutely unnecessary to stop the lens down with this shutter, while with any other type it is necessary to use a much smaller aperture to secure the same amount of definition, which would mean a great loss of illumination.

708. The shutter has only one spring for all of the different exposures, and is always ready for a new exposure without being open for resetting. In general construction the principle of this shutter is compound in the true sense. The spring is subjected to two strains, bending and twisting. Both of these strains grow in increasing ratio, so that a very weak spring on the highest tension is a very powerful motor for a shutter movement.

709. The movement of the four blades is again compound. Starting in an almost straight direction they are thrown over very quickly and settle in a straight direction, having changed their position in the shutter altogether. This straight starting and setting bring all strains right to the restrengthened centers of the blades, and regulates the definition and illumination through slow opening and setting and quick full exposure. The same ratio in exposure is kept for speeds of several seconds or 1-2000 part of a second.

710. The shutter opens from the center of the lens, with an increasing star shaped opening. The blades expose full in the middle of the movement and close again from a different point of the circumference of the lens aperture. In this way the circumferential rays are allowed to act longer on the sensitive plate than the rays at the center.

The exposure excess, therefore, appears as a maltese cross laid diagonally.

711. The results are that the corners of the plate are longer exposed than the center, thus absolutely counteracting vignetting even on wide angle work on large plates and at highest speeds. This shutter is one of the most excellent all around instruments of the kind obtainable, as it is equally well adapted to landscape and interiors, also for moving objects requiring the highest speed efficiency of the shutter.



SOME BEGINNERS' NOTES ON INSTANTANEOUS SHUTTERS.

712. Noise and speed are not necessarily connected. A shutter may make a loud bang, and yet not be as fast as one which works almost noiselessly.

713. One of the essentials of a truly high speed shutter is lightness of the moving part.

714. Some shutters are set by a cord, which hangs loose until the shutter is liberated. If the cord is allowed to catch in anything—and the wind may blow it where it will be caught—the exposure will be spoiled.

715. For hand cameras the pneumatic release is rarely an advantage; in fact it increases the risk of movement. With a camera on a stand it is exactly the reverse; there is much less chance of shaking it when the bulb and tube are employed.

716. A shutter that fits on the front of a lens should have its opening wider than that of the hood, particularly if the shutter is a thick one. If not, the shutter will not fully uncover the lens.

717. No shutter actuated by a spring should be put away for any length of time with the spring in a state of tension.

718. **Focal Plane Shutters.**—The “focal plane” means the position that the plate should occupy for the picture upon it to be sharp; hence a *focal plane shutter* does not actually work in the focal plane, or it would be in contact with the plate it should expose—but it ought to be very near it. Illustration No. 51*b* shows the Graflex Focal Plane Shutter, while in Illustration No. 51*c* its relative position when fitted to ordinary hand or view cameras is clearly demonstrated. As explained in paragraph 695, there are two general types of curtains employed in focal plane shutters. One of these types is shown in Illustration No. 51*d*; the other is only one-fifth as long, the slot or opening being adjustable, instead of a definite width as is the case in the Graflex shutter illustrated. The focal plane shutter is a very important part of the *reflecting type of cameras*, the principle of which instrument is shown in Illustration No. 51*a*. The lens always remains open, the image being cast on a mirror, which, in turn, reflects it onto a horizontally placed ground-glass in the top of the camera. When the exposure is to be made the mirror is thrown upward, by pressure on a lever, and at the instant the mirror is out of range of the lens the focal plane shutter is released, making the exposure on the sensitive plate.

719. **Wollensak Shutters.**—The shutters manufactured by the Wollensak Optical company, illustrated on page 316*b*, are of a most practical and durable construction. The **Autex Shutter**, shown in Illustration No. 51*e*, is a type of the later models which are now superseding the automatic and regular shutters previously on the market. The **Optimo Shutter** (see Illustration No. 51*f*) has a range of automatically controlled exposures, ranging from one second to $1/300$ of a second, the latter being sufficiently fast to cover any emergency. The high speed efficiency is made possible by the star-shaped aperture formed by the points of five leaves which, in turn, revolve in making the exposure. The **Studio Shutter** (see Illustration No. 51*g*) is made especially for the professional photographer, and its Iris diaphragm principle of construction is also one of special merit, as the shutter thus acts as a diaphragm.

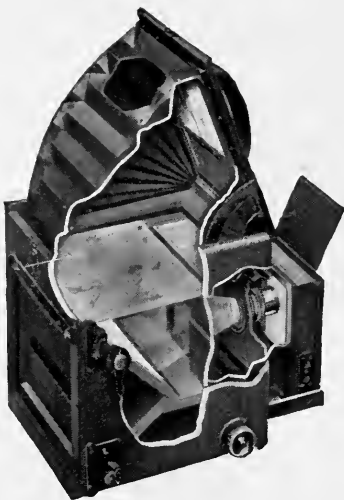
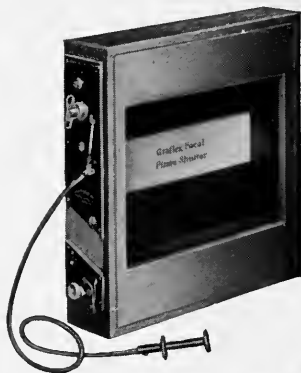

Illustration No. 51a.
Sectional View Showing Graflex Principle.
See Paragraph No. 718.



Ill. No. 51b.
Graflex Focal
Plane Shutter.
See Par. No. 718.

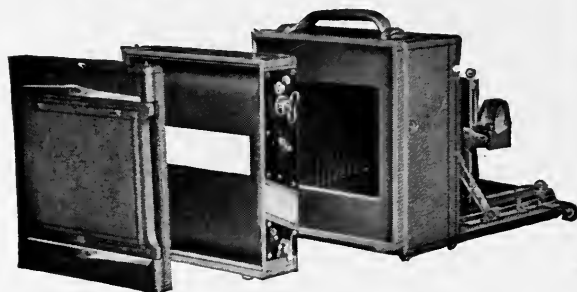

Illustration No. 51c.
Showing Relative Position of Focal
Plane Shutter.
See Paragraph 718.



Ill. No. 51d.
Curtain of Graflex
Focal Plane
Shutter.
See Par. No. 718.



Illustration No. 51e.
Wollensak Autex Shutter.
See Paragraph No. 719.



Illustration No. 51f.
Wollensak Optimo Shutter.
See Paragraph No. 719.



Illustration No. 51g.
The Studio Shutter.
See Paragraph No. 719.

CHAPTER XXXVII.

BAUSCH & LOMB LENSES.

720. As leaders in the manufacture of photographic lenses and shutters, we mention the well-known name of the Bausch & Lomb Optical Company, whose extensive factory is located at Rochester, N. Y. This company produces many lenses after their own formulae, but they are also the sole American manufacturers of the world-famous Carl Zeiss Lenses, including Planar, Unar, Tessar and Protar. These are produced under contract which the Bausch & Lomb Optical Company has as the sole American licensee, under identically the same formulae, methods of production and critical tests in process and after completion. All changes and improvements are immediately imported and carried out by these people. The following detailed descriptions of Bausch & Lomb lenses have been carefully prepared and contributed by the Bausch & Lomb Optical Company:

721. Our aim is the production of perfect lenses. To this end we are constantly introducing new and improved machinery and methods. Each element that enters into the manufacture of our products, as well as the completed article, is subjected to the most accurate and exhaustive tests, to demonstrate its optical and mechanical construction before it is allowed to leave the factory.

722. **The Bausch & Lomb-Zeiss Tessar** is an unsymmetrical doublet of four very thin lenses (See Illustration No. 52) made of a new type of Jena glass manufactured especially for this purpose. The front lens is uncemented, the two elements being divided by very appreciable air space. The rear lens is cemented. The front and rear combinations

are separated sufficiently to allow the Volute or Iris Diaphragm Shutters to be properly fitted. Tessar construction is essentially characterized by simplicity.

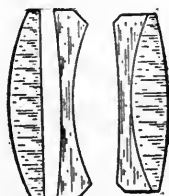

Illustration No. 52

723. The Tessar lens is light and compact, and therefore particularly suitable for use with the hand camera. The actual size of the 4 x 5 Tessar is shown in Illustration 53.

724. **Optical Qualities.**—*Definition*—Here the Tessar lens stands supreme. The image possesses a sharpness and crispness not previously thought of in connection with such great aperture and rapidity. The corrections are perfect, the accuracy and precision of the image extending over a field of great angular area.

725. *Illumination.*—Because of the small number of lenses, Tessar gathers a marvelously strong beam of light and transmits it with undiminished intensity. The illumination is characterized by unusual uniformity from center to margin of plate.

726. *Rapidity.*—Because of this unusual light-gathering power a rapidity indicated by f.6.3 is attained. This is sufficient for all kinds of instantaneous photography.

727. *A lens combining such simplicity of construction and such speed with equally uniform illumination and precise definition has never before been placed on the market.*

728. **Application.**—*Hand Camera*—Tessar is light and compact and may be fitted to any hand camera. In the shorter foci it is particularly adapted to use with cameras of fixed extension employed for instantaneous work.

729. **Portraiture and Groups.**—Here Tessar's speed,

accuracy of definition, depth of focus and flat field give it an important place.

730. Landscapes.—Tessars of long focus produce excellent results in landscape work. Objects in the distance and in the foreground are depicted with marvelous accuracy.

731. General Work.—None of the Zeiss series is so universally adapted to all the requirements of photography as is the Tessar, save only the Convertible Protars with their universality of focus. Superior optical qualities, choice of long or short focus, compactness of the new mounting and the applicability of the Volute shutter, make Tessar the most satisfactory of the entire Zeiss series when one lens alone must serve for all kinds of work. Tessar may be relied upon absolutely in those instances where the conditions of artistic and pictorial photography are peculiar and unusual.

732. Process Work.—The uniform brilliancy and definition characteristic of Tessar make it particularly applicable to industrial and reproductive photography where these two qualities are of such importance. For projection, copying and enlarging Tessar will give satisfactory returns. For process work there is no better lens to be had on the market. It is capable of giving the most precise delineation of objects in half-tone and line engraving. Indeed, its microscopic definition, while working at the large relative aperture of $f.6.3$, makes it the objective *par excellence* for half-tone work. We cannot impress the merits of Tessar too highly upon all who are thinking of purchasing new or added equipment for this class of photography.

733. Three-Color Work.—We manufacture a special lens known as the Apochromatic Tessar, with a rapidity varying in the numbers of the series from $f.10$ to $f.15$. This lens stands alone in its applicability to three-color printing as it is corrected perfectly for three regions of the spectrum, and thus the photographer is enabled to proceed with his work, substituting one after the other the three ray filters employed in this branch of the art, without vary-

ing the size or focus of the image and consequently without the inconvenience of additional focusing and manipulation incidental to the use of lenses not corrected apochromatically. In this field the merits of the Apochromatic Tessar guarantee it a deserved popularity.

734. **An Incidental Advantage.**—Attention is called to the fact that another desirable feature is the moderate price at which it is possible to place Tessar lenses on the market. This is due to the simplicity of construction, which requires less actual material and less labor than does the complicated manufacture of the average high grade lens.

735. **Tessar Lens, Series I-C.**—It has been found possible to increase the aperture without sacrificing brilliancy, definition and flatness of field, and the result is a new lens of the Tessar type, having a speed of $f.4.5$; that is to say, the new lens is twice as fast as the Tessar $f.6.3$, which has been so favorably received and is so well known. This lens is known as the Series I-C, and is shown in Illustration No. 54.

736. **This Gain in Speed** is a most important consideration to the *newspaper photographer* and others engaged in speed work, and makes it possible to secure pictures of rapidly moving objects with a sharpness of definition hitherto unattainable. This speed of $f.4.5$ is not restricted to the smaller sizes, but extends to all the lenses up to the largest foci.

737. **Illumination and definition** are not only better in the center than in other lenses, but extend more evenly over the entire field. Its optical corrections are so exceptionally good as to render it well adapted for the use of process workers.

738. **The New Tessar** will also be found unsurpassed for instantaneous exposures, portraits, groups and landscapes.

739. **The Bausch & Lomb-Zeiss Protar Lens** is made in various series and embraces a great variety of speeds, ranging from $f.8$ to $f.18$. The Series II has for its chief aim a lens combining rapidity and great extent of field. The speed is $f.8$, which is fast enough for ordinary instantana-



BAUSCH & LOMB
LENSES

TESSAR
Actual Size
Illustration No. 53
See Paragraph No. 723



TESSAR
Actual Size
Illustration No. 54
See Paragraph No. 735



PROTAR
Actual Size
Illustration No. 55
See Paragraph No. 741



BAUSCH & LOMB
LENSES

PROTAR
Actual Size
Illustration No. 57
See Paragraph No. 748



PLASTIGMAT
Actual Size
Illustration No. 62
See Paragraph No. 760



RAPID UNIVERSAL
Actual Size
Illustration No. 66
See Paragraph No. 762

neous work. The angle of view is 75 degrees, of which 60 degrees are utilized on the various plates. The definition which the lens produces is excellent, for with it detail is obtained with faultless exactness. This lens was primarily intended for hand camera work, and is suitable for this work because of its neat and compact mounting, short focus, applicability of the shutters and excellent optical qualities. This lens is an unsymmetrical doublet, neither system of which can be used singly. This lens should always be selected for hand cameras when symmetrical construction is not desired and when a medium wide angle lens is considered necessary. Its focus is shorter than that of other lenses, while at the same time the covering capacity is quite equal to that of the rest.

740. **In a studio** where space is limited and good lighting conditions exist, the remarkable depth of focus renders this lens suitable for groups.

741. **The Series IV. of the Protar Lens** works with a speed of f.12.5. The angle of view of this lens is 100 degrees in the six smaller sizes, and 85 degrees in the larger. The actual size of the 5 x 8 lens is illustrated in Illustration No. 55, while the cross-sectional view of the optical construction is shown in Illustration No. 56. This lens combines the two

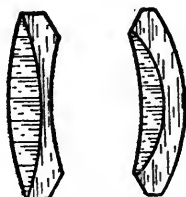

Illustration No. 56

important qualifications: That of wide angle aperture and speed of unusual extent. It may be classed as a medium angle lens, and is listed as such, giving sharp, well covered pictures, free from the ordinary distorted edges, a very important feature for a lens of this character, especially for outdoor Architectural Photography. Its use as an extreme wide-angle, however, is not precluded if the next

smaller lens to the one listed is selected, or a given lens is used on the next size plate. Its speed is such that it will give instantaneous exposure, and it is particularly valuable for flashlight exposures of large gatherings.

742. **Series V.** is intended for the most exacting wide angle photography. For this purpose it is one of the most desirable lenses made, and should be selected whenever an extreme wide angle lens is required, as in architectural and interior work. The anastigmat and spherical corrections are practically perfect. The images produced by this lens are entirely free from distortion from center to margin of plate, even with the most extreme angle.

743. The larger sizes are designed specially for copying, and for that purpose produce unexcelled quality of work. The angle of view is 110 degrees in size up to, and including, No. 7A. Above that number the full angle is 90 degrees. The speed of this lens is $f/18$, which is sufficient for most outdoor instantaneous work in sunlight.

744. In Illustration No. 57 is shown the Bausch & Lomb-Zeiss **Protar, Series VII A**, which lens is the result of efforts made to construct objectives of universal application. This lens is composed of two Series VII. lens, each system of which can be used separately, and when so used the speed is $f/12.5$. When the combination of systems is employed greater speed and greater effective angle are secured, the speed being $f/6.3$.

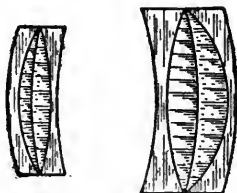

Illustration No. 58

745. When the two **single** anastigmats have different focal lengths, or foci, the lens is convertible into three individual, perfectly corrected anastigmat objectives in one.



Illustrations No. 59 and 60—See Paragraphs No. 753 and 754

OFFICIAL TEST OF HIGH-PRESSURE WATER MAINS TRAVERSING THE PHILADELPHIA "FIRE BELT." The upper of these two pictures was made with Series VIIA, No. 17, with 12 inch focus. The lower picture was made with the rear combination of the same lens.



Illustration No. 61

Relative size of image in a picture made with a No. 8 Series VIIA
1) Made with doublet. (2) With rear combination. (3) With front combination.
See Paragraph No. 755

When the single elements have the same foci, two separate objectives may be formed.

746. By the addition of one single anastigmat, six lenses, three single and three doublet are obtained, each with different angle, focus, and covering power.

747. The addition of two single anastigmats gives ten lenses, four single and six doublet.

748. A general exterior view of this lens mounting is shown in Illustration No. 57, while Illustration No. 58 shows the optical construction when the two single anastigmats which make up the combined lens are of different foci.

749. The photographer possessing this convertible lens is able to meet with practically all conditions of universal photography, the single elements being used for landscape work and other purposes where long focus, medium speed, or low or medium angle are sufficient. The doublet gives an extra rapid lens of wide angle, suitable for fast instantaneous work, most difficult architectural subjects, and any situation where speed, angle, covering power, depth of focus and brilliancy are required.

750. The average angle of view utilized on the different plates is about 55 degrees.

751. When the foci of the two single elements are the same the speed is $f/6.3$; when different, $f/7$ or $f/7.7$.

752. For hand cameras these lenses stand at the head of the list, both in optical qualities and in their adaptability to the limited space allowed for the lens. In selecting the lens be sure that the back focus of no combination is longer than the greatest extension of which your camera bellows is capable.

753. In Illustration No. 59 we illustrate the use of the Series VII A, No. 17, with 12 inch focus. The picture shows the official test of high-pressure water mains traversing the Philadelphia "fire belt."

754. Illustration No. 60 was made with the rear combination of the same lens.

755. Illustration No. 61 illustrates the relative size of image in pictures made with a No. 8 Series VII A Protar

lens; (No. 1) made with doublet; (No. 2) with rear combination; (No. 3) with front combination.

756. **Bausch & Lomb Plastigmat Lens.**—This is a strictly anastigmat lens. We have accomplished the purpose so completely that this lens is giving an exceptionally great amount of satisfaction to all its users. The lens has great speed, crisp definition over a large circle, wonderful covering power and even illumination. It is a symmetrical lens, the front and rear combinations being composed of four lenses each. The glass used is very transparent and absolutely permanent. The lens works with a speed of $f/6.8$.

757. **The separate systems** show truly remarkable covering power. The rear combination can be used at a speed of $f/13.5$; the focal length being nearly twice that of the doublet, and therefore the images produced are twice the size at the same distance, or the same size at twice the distance.

758. **Excellent perspectives** can be obtained with these lenses, because the focus is longer for the various plates than is usual in other anastigmats.

759. **This lens is particularly well adapted** for use with the hand camera, because of its excellent optical properties, light weight, compact form, and the applicability of shutters between the lens combination. It is an ideal lens for general photography, and we can recommend it in every respect when a lens of the highest optical excellence is desired.

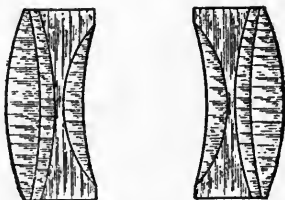

Illustration No. 63

760. We show the actual size of the 4×5 Plastigmat lens in Illustration No. 62, and in Illustration No. 63 is shown a sectional view of the optical construction.

761. Illustration No. 64 is a photograph of Mount Shasta, at a distance of seven miles, made with the Doublet Plastigmat, by H. H. Derr. In Illustration No. 65 is shown Mount Shasta from the same point, the negative having been made with the single combination of the Plastigmat lens.

762. **Extra Rapid Universal Lens.**—This lens is the most rapid of the rectilinear type, working as it does at a speed of $f/6$ and covering an angle of view of 70 degrees. Although this lens is far from equal to the anastigmats, it is a good lens for general work and gives admirable service

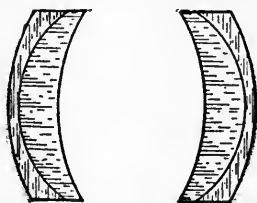

Illustration No. 67

for rapid instantaneous photography and portraiture in the gallery and home. As will be seen from Illustration No. 66, the mounting is very compact, and the lenses, although of large diameter (See Illustration No. 67), are thin and do not appreciably increase the weight.

763. We manufacture another rectilinear lens, known as the **Rapid Universal**, having a speed of $f/8$, its angle of view being 60 degrees. This lens is the original rectilinear or symmetrical type introduced by us, and it was an important factor in the making of our reputation for the manufacture of photographic products.



Mt. Shasta at distance of seven miles, made with doublet plastigmat by H. H. Derr
Illustration No. 64—See Paragraph No. 761



Mt. Shasta from some angle

GOERZ LENSES



CELOR
Illustration No. 68
See Paragraph No. 803



Illustration No. 69
See Paragraph No. 803



DAGOR
Illustration No. 70
See Paragraph No. 810

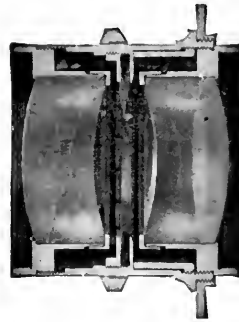

Illustration No. 71
See Paragraph No. 810

CHAPTER XXXVIII.

GOERZ ANASTIGMAT LENSES.

By the C. P. Goerz American Optical Company.

764. The introduction of anastigmat lenses may certainly be considered the most notable step in advance in the field of photographic optics made during the last twenty years. In this instance, as in the case of all scientific progress, the improvements are not the work of one man, but result from the joint labors of an army of scientists, each member of whom contributed his share toward the achievement of progress.

765. We feel proud of the right to rank ourselves among the first workers in the vast field of research that was opened to manufacturers of optical instruments by the advent of the now famous "Jena glass."

766. Duly impressed by the advantages gained by the use of symmetrical components in photographic objectives, we made a special study of the application of symmetry in the construction of anastigmatic lenses, and succeeded in producing and bringing upon the market, in 1893, the Goerz Double Anastigmat Lens, the first anastigmat of symmetrical construction. This became at once, and remains today, the standard of comparison for all anastigmatic lens.

767. The improvement in lenses, keeping pace with the improvements in the manufacture of plates and films, made possible the application of photography to a great many purposes where formerly its services were unknown. The art of photography is today intimately interwoven with the entire industrial and commercial activity of the world, and no event of any importance to mankind takes place, even in the most remote corner of the country, without being

photographically recorded and heralded to the millions. Modern anastigmat lenses made this possible.

768. **The main points of improvement and advantage** possessed by anastigmatic lenses over the older rectilinear type, is the power to give sharp definition at large aperture, and over a larger image surface than the older lenses could show. Additional advantages are gained by the close and compact build of the anastigmat as compared to the rectilinear lens. Besides increasing the field of the image, thereby making them useful as wide-angle lenses, the normal image is very evenly illuminated, a point in which the rectilinear type leaves much to be desired.

769. Although it may sometimes be advantageous to use lenses of comparatively long focal length, considering the required size of the image, it is an undeniable advantage not to be compelled to use such a long focal length in order to obtain satisfactory definition. In the case of the rectilinear lenses, we have no choice, but with the anastigmatic lenses we can give first consideration to any other condition and select the focal length imposed thereby, knowing that the covering power will always be sufficient.

770. In all Goerz Lenses, the *astigmatism* is completely corrected, with the result that even at full aperture the image is as sharp at the edge as it is in the center.

771. The *curvature of the field* is eliminated within an angle of 72 degrees—i. e., that part of the image which is comprised within that angle is absolutely flat. The *definition* and *depth* are the same in all parts of the field.

772. The co-existence of these two essential qualities—perfect anastigmatism and flatness of field—gives these lenses supremacy over all other existing types.

773. They are, besides, spherically and chromatically corrected for the *axial* and *oblique* pencils, even with the largest stop.

774. By reason of the symmetrical arrangement of the two combinations of the Goerz Lens, the image is perfectly orthoscopic, and all traces of distortion are obviated, *a priori*.

775. They are free from internal reflections and the images produced are accordingly *brilliant and free from flare*.

776. The glasses employed in the construction of Goerz Lenses are so chosen as to reduce the secondary chromatic aberration to an inappreciable minimum. Apochromatic correction is therefore well nigh perfect.

777. The symmetrical arrangement, which is a characteristic of these lenses, permits the use of the single combinations of either type, but this use has been considered as of secondary importance in all series except in the "Pantar" double anastigmats, which are specially designed as convertible lenses, and have thus been calculated to work with perfect sharpness of definition at the full aperture of the single elements (F. 12.5). When using the single elements of the Series III lenses, sharp definition is obtained at F. 13.5 for the smaller lenses (up to and including the No. 3), and at F. 16 for the larger numbers. The single elements of the type B lenses give soft definition admirably suited for large portraits at an aperture of F. 15, and critically sharp definition when stopped down to F. 22 and less.

778. **On the Selection of Lenses.**—When it is desired to use a photographic lens for more than one kind of work, the selection of the most suitable objective becomes a matter of careful thought. As to the so-called "all-around lens," so much desired by the great majority of amateurs, only instruments of moderate rapidity come into consideration. This is due to the fact that lenses of a rapidity exceeding f.6.3 cease to be useful for wide-angle views, even when worked with small diaphragm openings.

779. The longer the focal length of a lens the more decided are its special characteristics. Consequently, long focus lenses lack adaptability to a variety of purposes—whatever their rapidity may be. A lens for all-round photographic work should not exceed 8 to 10 inches in focal length, which limits the size of the camera to a $6\frac{1}{2} \times 8\frac{1}{2}$ outfit. Applying these considerations to actual practice we find that an outfit suitable to fill the greatest possible number of uses should preferably consist of a camera 5×7

inches, or $6\frac{1}{2} \times 8\frac{1}{2}$ inches, with an f.6.8 lens, either of $8\frac{1}{4}$ or $9\frac{1}{2}$ inches focus. When long range work is a factor of importance, it would be preferable to select a convertible Pantar of corresponding focal length, as the single members of these objectives are particularly suitable for long range views. When the requirements go beyond the possibilities of such equipment, they are no longer to be considered as part of a variety of purposes, but lead to the use of special instruments.

780. The principal branches of special work are *portraiture and commercial photography*. By the last term we refer to the photographing of machinery, furniture, glass and silverware, etc.

781. **In portraiture** great rapidity of the lens is, of course, an important point. We, therefore, select the fast lenses for this work, such as an f.4.5 or f.5.5. The covering power of these lenses is so great that it needs no special consideration; but attention must be given to the choice of the most suitable focal length. The size of the portrait desired should be the controlling factor in the selection of a portrait lens, and practice has proven that the most pleasing results are obtained by the use of a lens, the focus of which is twice the length of the largest "bust" which it is to make. For instance, on an 8 x 10 plate one can properly make a "bust" measuring 7 inches from the top of the head to the chest. A lens of 2 x 7 inches=14 inches focus, will do this at a comfortable distance, insuring good perspective. In short operating rooms it is not always possible to follow the above rule, but, wherever possible, it is very desirable to adhere to it. The degree of sharpness of definition is entirely in the control of the operator, and can be changed from the most critical sharpness to the softest diffusion.

782. **For commercial work** the principal condition is a fine perspective effect. This can be secured by using a lens of great focal length, so that the camera can be set up at considerable distance from the object. Owing to the great depth of focus required in such case, and therefore the compulsory use of small diaphragms, it is not desirable to em-

ploy extra fast lenses for such work. An f.6.8 lens is perfectly suitable, as it permits of a sufficiently large aperture for easy focusing, and will produce the maximum possible depth of focus when stopped down to the smaller diaphragms.

783. **Determining Focal Length of Lens Suitable for Operating Rooms of Stated Length.**—As it may be valuable to many photographers to know how they can determine the focal length allowable in operating rooms of limited length, we will give here the simple rules which govern the relations between focal length, size of image, and distance of the subject. When speaking of focal length we always refer to the *principal* or *equivalent focus*, which is the distance from the optical center of the lens to the surface of the plate when the object is at a very great distance.

784. **Note:**—For all Goerz lenses the optical center is situated in the plane of the diaphragm, and from that point the focus should be measured.

785. When making a picture n times smaller than the original, the object should be at a distance of $(n+1)x$ focus from the lens. If this distance is limited to D feet= $12D$ inches on account of the available space, it will be clear that

$$12D$$

$12D = (n+1)$ focus, or focus $\frac{12D}{n+1}$ inches. *To illustrate:* What

should be the proper focal length for making a standing full-length cabinet portrait in a room 12 feet from wall to wall? This leaves, after allowing space for background and length of camera and moving space for operator, a clear distance of 8 feet between lens and sitter; thus, $D = 8 \times 12 = 96$ inches. A full-length cabinet picture measures $4\frac{3}{4}$ inches from head to feet. Now, assuming the person to be

$$70$$

5 feet 10 inches tall, $n = \frac{70}{5 \times 12} =$ say 14.5. We can now write

$$4.75$$

$\frac{12D}{n+1} = \frac{96}{15.5} = 6.18$, or say, 6 inches.

$$n+1 \quad 15.5$$

786. As there is still in the minds of some photographers a great deal of misapprehension regarding the presence of some occasional air bubbles in the glass of high-grade anastigmats, we think it advisable to publish the following communication from Messrs. Schott & Genossen, the manufacturers of the celebrated Lens Glass, the discovery of which has rendered possible the construction of the modern anastigmat.

787. *Communication from the firm Schott & Genossen, Jena (Germany) Glass Manufactory for Optical and other Scientific Purposes:*

The efforts of opticians, during the last few years, to improve lenses in their higher optical characteristics, have led to more extended use of glasses in the manufacture of photographic objectives, which differ widely in their optical properties and chemical composition from the crown and flint glass hitherto employed. Their manufacture is attended, to some extent, by far greater technical difficulties than are involved in the production of the optical glass formerly in current use. In the manufacture of the majority of the new kinds of glass which have taken front rank in the construction of improved photographic lenses, there are exceptional difficulties in securing perfect purity, i. e., freedom from small bubbles. The definite demands which have to be met to obtain relative dispersion and refraction differing from usual conditions, impose such stringent limitations upon the chemical composition of the glass fluxes, that no play is left to the manufacturer technically to provide suitable conditions for obtaining perfect purity. In consequence of this, it is practically impossible to supply these kinds of glass in uniform pieces free from a few small bubbles.

788. We would, however, point out that the presence of these small air bubbles, even under most unfavorable conditions, does not occasion a loss of light exceeding 1-50 per cent., and their influence upon the optical efficiency of a lens system is, therefore, of no moment whatsoever.

789. It is manifestly unfair to require that the manufacturer should reject nine-tenths of the glass which is made,

simply because it shows a fault that is of absolutely no importance in practice, notwithstanding the fact that he is able to satisfy the higher demands of the optician with regard to all the really important properties the glass should possess for the functions of the lens.

790. If purchasers make the usual objection that a lens is "faulty" because of a few small bubbles, the optician must kindly explain that lenses of the highest class cannot be made of any sort of crown and flint, and that more important considerations have to be taken into account in selecting the glass than the absence of a few small bubbles.

GLASTECHNISCHEN LABORATORIUM,
Schott & Genossen.

791. **Relative Exposures for Varying Proportions of Image to the Original**, by W. E. Debenham. Reproduced from "The British Journal Photographic Almanac."—When an enlarged photograph has to be made, either from a negative or print, it is commonly understood that the greater the degree of enlargement the longer will be the exposure required; but I have generally found only the vaguest ideas to exist as to the amount by which such exposures have to be prolonged. Sometimes, indeed, it is assumed that the exposure will be in direct inverse proportion to the area covered, so that a copy of twice the linear dimensions of the original—covering, as it does, the area of four times the size—would require an exposure of four times that sufficing for a copy of the same size. This calculation, however, omits to recognize an important factor and leads to serious error, the actual exposure required in the case mentioned (assuming the same lens and stop to be used) being not four times, but two and a quarter times that of a copy of same size; whilst, when we come to high degrees of enlargement, the error would amount to an indication of nearly four times the exposure actually required.

792. To find the relative exposure add one to the number of times that the length of the original is contained in the length of the image, and square the sum. This will give

the figure found in the third column of the annexed table. (See Paragraph No. 798.)

793. As examples: Suppose a copy is wanted having twice the linear dimensions of the original. Take the number 2, add 1 to it, and square the sum, $3^2=9$. Again, if a copy is to be of eight times the linear dimensions of the original, take the number 8, add 1, and square the sum, $9^2=81$. Copies respectively twice and eight times the size (linear) of the original will thus require relative exposures of 9 and 81—i. e., the latter will require nine times the exposure of the former.

794. It is convenient to have a practical standard for unity. An image of the same size as the original is a familiar case, and serves as such standard. By dividing the figures in the third column by four, we get at the figures in the last column, which represent the exposure required for varying degrees of enlargement or reduction, compared with the exposure for a copy of the same size.

795. The table is carried up to enlargements of thirty diameters. That is about the amount required for enlarging a carte-de-visite to life size.

796. The exposures required in reductions do not vary to the same extent that they do in enlargements. It has, therefore, not been thought necessary to fill in the steps between images of 1-10 and 1-20, and between 1-20 and 1-30 of the size of the original. Beyond 1-30 there is scarcely no perceptible difference in the exposure until disturbance comes from another cause, a considerable distance of illuminated atmosphere (haze or fog) intervening.

797. The figures in the second column will also serve as a table for distances from the lens to the plate, and to the original; all that is necessary being to multiply by the principal focus of the lens in use. In the case of enlargements the figures less than 2 must be multiplied to get the distance from the original to the lens, and the figures greater than 2 for the distance from the lens to image. For reductions, the figures less than 2, multiplied by the principal focus of the

lens, yield the distance from lens to plate; and the figures higher than 2, similarly multiplied, give the distance of original from lens.

798.

Proportion of image to original (linear)	Distance of image from lens* in terms of principal focus	Proportionate exposures	Exposures proportioned to that required for copying same size
$\frac{1}{30}$	$1\frac{1}{30}$	1.07	.27
$\frac{1}{20}$	$1\frac{1}{20}$	1.10	.28
$\frac{1}{15}$	$1\frac{1}{15}$	1.21	.3
$\frac{1}{10}$	$1\frac{1}{10}$	1.27	.31
$\frac{1}{8}$	$1\frac{1}{8}$	1.36	.34
$\frac{1}{6}$	$1\frac{1}{6}$	1.56	.39
$\frac{1}{4}$	$1\frac{1}{4}$	2.25	.56
$\frac{1}{2}$	$1\frac{1}{2}$	3.06	.76
(Same size) 1	2	4	1
2	3	9	2.25
3	4	16	4
4	5	25	6.25
5	6	36	9
6	7	49	12.25
7	8	64	16
8	9	81	20.25
9	10	100	25
10	11	121	30.25
11	12	144	36
12	13	169	42.25
13	14	196	49
14	15	225	56.25
15	16	256	64
16	17	289	72.25
17	18	324	81
18	19	361	90.25
19	20	400	100
20	21	441	110.25
21	22	484	121
22	23	529	132.25
23	24	576	144
24	25	625	156.25
25	26	676	169
26	27	729	182.25
27	28	784	196
28	29	841	210.25
29	30	900	225
30	31	961	240.25

* With a double lens it is usually sufficient to measure from the position of the diaphragm-plate.

799. **Increase of the Focal Distance of the Lens Due to Different Distances of the Object.**—A certain distance exists for each lens, at and beyond which the parallaxes of the luminous points are so small that the incident rays may be considered to be parallel to each other. In this case the distinct image is situated in the principal focal plane of the lens—i. e., in the plane which is conjugate to infinitely distant objects. The subjoined table shows how far, in the case of our lenses, the distant image lies behind the principal focal plane when the object is situated at a finite (and rather short) distance from the lens.

800.

No. of Lens	0	1	2	3	4	5	6	7
Focus in inches	4¾	6	7	8½	9½	10¾	12	14
Distance of Object in feet	Distance of the Conjugate Focus beyond the Principal Focus in inches							
16660012	.0020	.0028	.0036	.0048	.0060	.0072	.0104
3330056	.0092	.0128	.0174	.0232	.0292	.0360	.0520
1660116	.0180	.0260	.0352	.0464	.0584	.0724	.1044
1000192	.0300	.0436	.0592	.0776	.0980	.1212	.1748
660288	.0452	.0652	.0892	.1164	.1476	.1838	.2640
500388	.0604	.0872	.1192	.1560	.1980	.2448	.3540
400484	.0760	.1096	.1496	.1960	.2484	.3080	.444
330584	.0912	.1320	.1800	.2360	.2996	.3716	.536
300648	.1016	.1468	.2008	.2628	.3340	.412	.600
270732	.1144	.1656	.2264	.2968	.3772	.468	.680
230836	.1312	.1900	.2600	.3408	.432	.536	.780
200976	.1540	.2228	.3048	.4000	.508	.632	.920
171180	.1856	.2688	.3684	.4840	.616	.764	1.116
131484	.2336	.3392	.4640	.6120	.784	.972	1.424
102000	.3160	.4600	.6220	.8360	1.068	1.332	1.964
73064	.488	.7120	.9840	1.3080	1.684	2.116	3.160
3656	1.060	1.5800	2.2320	3.0320	3.996	5.16	8.12

801. This table is very instructive. It shows, e. g., that lens No. 0, in the case of an object situated at a distance of 166 feet requires a displacement of only .0116 inch of the focusing screen (with respect to its position in the plane of the principal focus), whereas lens No. 7 requires this displacement when the object is at a distance of 1,666 feet. Since, with the rapidities ordinarily employed, a difference of .016 inches in the position of the focusing screen does

not produce any sensible diffusion, we see from the table that lens No. 0 is capable of simultaneously sharply depicting objects situated at a distance beyond 50 feet; No. 7, those beyond 1,666 feet; No. 9, however, only those beyond 3,333 feet, etc. In general, the table shows that *caeteris paribus*, *i. e.*, with the same relative apertures or with the same rapidities, the depth of focus rapidly diminishes as the focal length increases.

802. This table may be employed to sharply focus an object without the aid of the focusing screen, when the distance of the former is approximately ascertained by pacing off, or otherwise known.

803. **Goerz Celor.**—F. 4.5—F. 5.5 (Series I B Extra Rapid Apochromatic).

Special Objective for fastest instantaneous exposures, portraits in room and studio; enlargements and reproductions; three-color process; telephotography; projections. Also for landscape and architectural views, and for all purposes requiring extreme speed. (See Illustrations No. 68 and 69.)

804. There are on the market several anastigmat lenses working at a great relative aperture. Theoretically, their speed leaves nothing to be desired; but when they are used at full aperture the extent of the field sharply covered is not sufficient to allow one to make practical use of their speed.

805. To overcome this difficulty the focal length of these lenses is generally increased, which accentuates all the more the lack of "depth of focus," already very noticeable because of their large relative aperture. Consequently, a fast lens to be really serviceable for general photographic work, should not only possess speed, but should at the same time cut sharply, at full aperture, an image contained within an angle of 60 degrees, or, in other words, a plate the longer side of which is about equal to the focal length of the lens.

806. The Celor Lens combines these properties. It has its place, therefore, in all up-to-date studios.

807. We claim that Celor lenses are superior to all ✓

other anastigmats of equal maximum aperture, because of their larger field of sharp definition at full aperture. This enables one to select a Celor lens of shorter focal length than that of other similar anastigmats, an important consideration where the length of the studio is limited. This is a great advantage for the photographer, meaning, as it does, a gain in the depth of focus, and incidentally in actual working speed.

808. The back combination of the Celor can be used as a single lens of double the focal length. At F. 32 it will yield about the same definition as the whole lens and twice the covering power of the latter.

809. **Goerz Dagor.**—F. 6.8 (Series III.) Universal extra-rapid lens for landscape, architectural, portraits, groups, instantaneous photography, interiors, and scientific work of all kinds.

810. Although it is but a few years since public attention was first attracted to the Goerz Double Anastigmat Dagor (Series III.), these lenses have won the most extended recognition, not only from authorities in photographic optics who have been in position to exhaustively test their merits, but from the photographic confraternity at large, whether amateur or professional. (See Illustrations Nos. 70 and 71).

811. The Dagor lens is a universal instrument in the full sense of the word, and comes as near being an all around lens as can be hoped for, considering the manifold and complex requirements of the photographic craftsman.

812. Each Goerz Double Anastigmat Dagor supplies 1st. *A rapid lens* for general purposes—portraiture, landscape, architecture, enlargements, etc., working at *full aperture* with extreme sharpness to the edges of the plate for which it is constructed. 2d. *A wide angle lens* for interiors and all views at short distances, sharply covering a much larger plate when smaller apertures are employed. 3d. *A long focus lens* for distant objects, when the back combination alone is used.

813. **Characteristics of Dagor Lenses.**—The *astigmatism* is completely corrected, with the result that, even at full aperture, the image is as sharp at the edge as it is in the center.

814. The *curvature of the field* is eliminated within an angle of 72 degrees—i. e., that part of the image which is comprised within that angle is absolutely flat. The *definition* and *depth* are the same in all parts of the field.

815. It is, besides, spherically and chromatically corrected for the *axial* and *oblique* pencils, even with the largest stop.

816. The Dagor lens is free from internal reflections and the image produced is accordingly *brilliant* and *free from flare*.

817. The two combinations are placed in close proximity; consequently, there is no falling off of the luminosity toward the edge, and the entire surface of the image is therefore uniformly illuminated. The compactness of the Dagor lens renders it extremely rigid and portable.

818. As a result of the symmetrical arrangement of the two combinations of the lens, either may be used as a single landscape lens, the focus of which is about double that of the entire combination.

819. **The Goerz Dagor (Series III.) as a Wide-Angle Lens.**—The exceptionally fine correction of the Goerz Dagor lenses over their entire light circle allows us to use them with the most perfect results as wide-angle lenses up to an angle of 90 degrees. They will give critical definition over the whole image subtended by this angle, when stopped down to U. S. 16 ($=f. 16$) or smaller. Their considerable luminosity at full aperture facilitates focusing materially, for which reason alone this type of objective is greatly preferable to the ordinary W. A. lenses. Furthermore, the angle they include is equal to that provided by most wide-angle lenses stated to give 100 degrees or 110 degrees, and are free from distortion. Though it be true that some lenses have a light-circle of this extent, *they do not utilize it on the plate*, being not sufficiently corrected to make their full angle avail-

able. An actual image angle of 60 degrees to 65 degrees is usually the maximum they produce.

820. **Note:**—To find accurately, without tedious mathematical calculations, the angle covered on any size plate by any lens, proceed as follows: Draw one line, AB, equal to the length of the plate used, or more exactly to the length of its *diagonal*. On the center of AB draw a perpendicular line CD, the length of which should be equal to the equivalent focus of the lens. Then join CA and CB, and with a protractor measure, at C, the angle Ca Cb, which read-

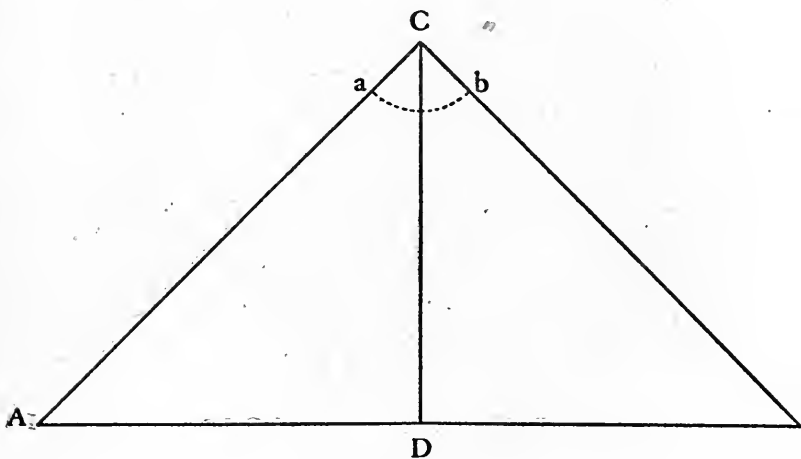

Illustration No. 72

ing will give you exactly the angle *actually* subtended by the lens on the size plate used. See Illustration No. 72.

821. **The Goerz-Anschütz Folding Camera** is a small, elegant hand camera, which is available both for instantaneous and time exposures (See Illustration No. 73). This camera is extremely compact and light, the $3\frac{1}{4} \times 4\frac{1}{4}$ weighing only 27 ounces, the 4×5 model 39 ounces complete.

822. The camera is opened for use by simply pulling

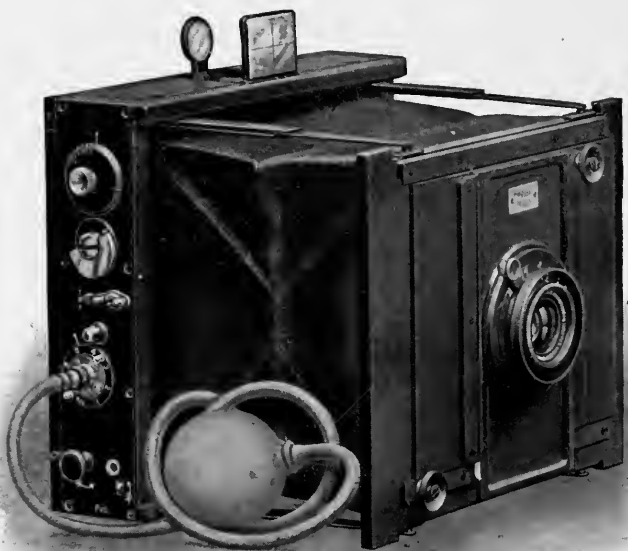

Illustration No. 73
Goerz-Anschütz Camera
See Paragraph No. 821



Illustration No. 74

the front out until the stays catch. Then the camera is as rigid as a solid box, the front remaining always perfectly parallel with the focal plane—a point of the greatest importance when lenses of large aperture are employed. The rapidity with which the camera is made ready, and its unobtrusive appearance, are two indispensable conditions for hand camera work, and in both respects the Goerz-Anschütz Folding camera is the finest camera on the market. Especially do we recommend this camera to all photographers who make enlargements or lantern-slides. The perfect rigidity of its front board is a priceless feature, as it alone will insure that perfect plane-parallelism of lens and plate or film surface, which is indispensable for that class of work. Fitted with a Dagor or Celor lens, the image-sharpness is so great that enlargements of 10 or 12 diameters (144 times in surface) are often mistaken for originals. No other folding hand camera can boast of such rigid construction.

823. The front board is adjustable, both vertically and horizontally, to enable the operator to regulate the field of view from any given standpoint. More especially a "rise" of the front is employed in order to limit the foreground or bring any tall object (a high building, for example) upon the plate.

824. While the camera is a fixed-focus instrument of admirable definition for general use, our lenses are fitted in a special focusing mount, which, by increasing the distance between lens and plate by means of a lever, permits the focusing of objects down to a distance of six feet. This mount is supplied with a focusing scale easily read from the position of the lever; in addition to which, each camera has a removable ground-glass back with extendable focusing hood, which can be used for focusing before each exposure, whether one is using plates, film-pack or roll-films.

825. Another advantage: The Goerz-Anschütz can be focused at the level of the eye. It takes the pictures as *we see them*, which no camera does which focuses at the height of the chest.

826. **Focal Plane Shutter.**—The most important fea-

ture of the Goerz-Anschütz Folding camera lies in the ingenious construction of the instantaneous shutter, which has recently been considerably improved. This new focal-plane shutter will not only give all the speed suitable for very rapid work—from 1-10 to 1-1000 of a second—but time and bulb exposures as well, and all slow automatic speeds from 1-10 to 5 seconds. It is the most perfect style of safety focal plane shutter made. The width of the slit is adjusted from the outside, and the slot of the shutter is automatically closed when the shutter is being set. This is a unique and invaluable advantage, especially when roll-films, film-pack, or magazine plate holder are used, as the sensitive surface is always and absolutely protected from the light. The lens may remain uncapped at all times, and be ready for immediate action.

827. It is without doubt the most perfect and most complete shutter on the market, and permits not only a wider range of speeds, but a surer adjustment of the exposure than is obtainable with any other construction. Another valuable feature of the Anschütz Shutter is that with it the full lighting power of the lens is available, while shutters placed close to the objective give considerably less intensity.

828. **The Goerz-Anschütz Stereoscopic Camera.**—The Goerz-Anschütz Folding camera is also supplied adapted for *stereoscopic photography* (See Illustration No. 74). This model is provided with an adjustment by which the separation of the lenses can be varied, a point of the greatest importance in practical work. The stereoscopic division can also be removed, and one of the lenses brought facing the center of the plate. By this means the camera is rendered available for extensive panoramic views. For this latter purpose it is recommended that the camera be fitted with the Dagors (Series III.), as these lenses have greater covering power than the Celors (Series IB). If fitted with the latter lenses, the panoramic adjustment is not supplied. The Celor lenses are set at a fixed separation.

CHAPTER XXXIX.

COOKE LENSES.

By Taylor, Taylor & Hobson, Ltd., New York City.

829. The Cooke Anastigmats differ from others, in that the lens consists of three glasses, and with this simple construction is combined a unique screw adjustment for use in making final corrections. Errors which remain in more complex systems are thus easily removed and a uniform excellence is attained, whereas the older anastigmats frequently show a marked difference one from another. Obviously, more light reaches the sensitive plate through three glasses than through six or eight. Moreover, there is no cement, and the adjustable air spaces assist still further in correcting the entire system. Since the first appearance of the lenses, European opticians have recognized that while mathematically perfect, these are mechanically the most simple invented since the introduction of Jena glass. They are light, compact, and rigid and durable to a remarkable degree.

830. These statements give reason why Cooke lenses are employed in astronomical observatories, and why they are used at Harvard. For difficult copying and enlarging they are invaluable. They are now used exclusively by the U. S. Geological Survey, and by other departments at Washington. In process-engraving works, throughout Europe and America, Cooke lenses are used under process-gratings of 250 lines or more to the inch. For tricolor-photography they are unique, because the screw adjustment gives an exact co-incidence in the sizes of the color-images.

831. While thus selected for the best scientific work,

Cooke lenses are used by amateurs everywhere, by engineers, in the portrait studio, by army and navy photographers, and by newspaper men who seek, above all else, rapidity and fine definition. Wherever possible, the makers facilitate the trial of Cooke lenses for comparison with others.

832. **Cooke Extension Lenses.**—By removing the back-glass and substituting another, the entire focal length is increased. Thus, from the same point of view the photographer obtains larger images of distant objects. These extension lenses increase the size of image about 50 per cent. For example: An object taken with the normal lens, two inches long in the photograph, is, from the same position, made three inches long with the extension lens. Better results are thus obtained than with portions of other types used alone. The normal Cooke lenses may be used upon

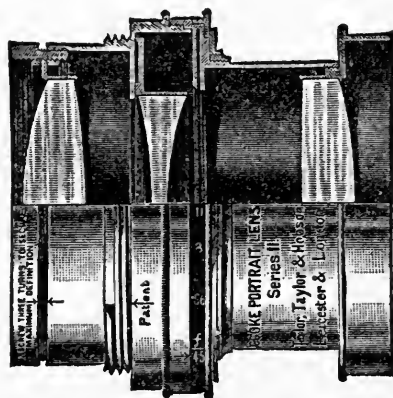

Illustration No. 75

plates many sizes larger than those covered by them with full apertures, but the extension lenses are not intended for this. The latter are supplied in leather pocket cases.

833. **Cooke Lens, Series II.**—Full aperture $F. 4.5$ (See Illustration No. 75). These ultra-rapid anastigmats are designed for the finest portraiture, and for subjects demanding extreme speed. Like other Cooke lenses, they give defi-

inition at the margins of the plates equal to that at the center, and are quite free from that peculiar streakiness or marginal definition familiar to the professional photographer.

834. The lenses numbered 22 and 23 are provided with the means for moving the back-glass as shown in the illustration. This device enables the photographer to secure at will uniformly sharp definition, or to introduce any required softness evenly throughout the plate.

835. The right choice of a shutter is of vital importance. The highest efficiency in photographing rapidly moving subjects can be secured only with focal-plane shutters, while for portraiture a suitable studio shutter is best.

836. **Cooke Lens, Series III.**—Full aperture F. 6.5. The Series III. lenses are the best for persons desiring all around anastigmats of the very highest grade. They are designed for general photography, landscapes, interiors, street scenes, and for difficult photographs on dull days. For use as wide-angle lenses on relatively large plates they are perfect. They may be focused wide open and afterwards stopped down, without spoiling the image. Briefly, they are universal lenses suitable for all accurate and rapid work requiring uniformly fine definition. Lenses of this series are the best for kodaks. The No. 3 lens can, if specified, be fitted to the No. 3 kodak, the No. 4 lens to the No. 3a, and the No. 6 to the No. 4a kodak.

837. **Cooke Lens, Series IV.**—Full aperture F. 5.6. The Series IV. lenses are designed for high-speed photography with focal plane shutters; for groups; for difficult photographs in exceptionally poor lights. The definition is perfect throughout THE SIZES OF PLATE SPECIFIED, even with the full aperture of F. 5.6. In that respect the lenses equal those of the Series III. and V., but they cannot be used with such good effect upon plates larger than those for which they are listed.

838. The advantages of a simple construction are fully developed in this series, and result in objectives of greater rapidity and defining power, with a more uniform excellence

than has hitherto been possible in lenses having such large aperture.

839. The right choice of a shutter is of vital importance. The Series IV. lenses can be fitted to the ordinary between-lens pattern, if specified, but the highest efficiency in the photography of rapidly moving subjects can be secured only with focal-plane shutters. For protraiture, a suitable studio shutter is best.

840. **Cooke Lens, Series V.**—Full aperture F. 8. The Series V. lenses are similar to the Series II., except for their smaller apertures and more compact mountings. Optically, the two series are identical and give equal results at similar apertures.

841. Especially suitable are the Series V lenses for copying, enlarging, machine photographing, and for everything demanding microscopically fine definition under average conditions of lighting. Success in government departments and astronomical observatories has been largely with lenses of this series.

842. **Cooke Process Lenses.**—The illustrations in the leading magazines throughout the world are now made with Cooke Process Lenses. The reason is that for such work they give uniformly well defined images, free from distortion, from fog, and other common defects of lenses; while for three-color work they have the unique property of being adjustable so that in final tests color images of equal size are secured.

843. The lens-hood which receives the cap is removable, and a screw-thread receives inter-changeably any prism or mirror suitably mounted and always in the correct position. An iris diaphragm is provided, in front of which is a slot to receive process diaphragms, if necessary. This slot may be closed or opened at pleasure, merely by revolving the inscription tube.

844. **How to Preserve Lenses.**—Lenses should be kept in a pure, dry atmosphere, away from dust and damp. These conditions impair the perfect polish of a high-class instrument, and by scattering some of the light which passes

through, produce a degree of fog in its images. Use an old, clean cambric handkerchief to remove dust. Never rub the glass, nor use whiting, leather, flannel, paper, or anything likely to contain a particle of grit; but brush lightly with such a smooth, soft duster as the before mentioned clean, old cambric handkerchief.

845. Hold the lens inverted and wipe the under side, that the dust may fall away from it.

846. A visible speck on the lens is of less importance than an invisible and general imperfection of polish, or a film of fine dust or moisture.

847. Lenses should not be left before a fire, nor in the sun to become unduly heated; neither should they be so cold, when used in a damp atmosphere, that moisture is condensed upon their surfaces.

848. In screwing together the parts of a lens, unless the screws are of Taylor, Taylor & Hobson's patent form, turn first in the wrong direction until the fittings snap together in a position for starting; then reverse the motion to screw them together.

849. **Blackening for Wood or Leather.**—An excellent blackening for wood or leather is made by mixing lamp-black with as much French polish as is needed to make it adhere sufficiently after being applied with a flat camel's-hair brush and allowed to dry. Too much polish will make the surface shiny, and too little will not secure the black pigment. The mixture may be made in a saucer and stirred with the brush, and thinned with a little wood alcohol, if necessary. It is well to try it first upon a piece of waste wood or card, and not to use it until the constituents have been so adjusted by trial. But it must be used quite freshly mixed. Purchased blackening is apt to be spoiled by long keeping.

850. **How to Test Lenses.**—The image formed by a cheap lens is "dished," whereas that of a fine anastigmat should be as flat as the plates themselves. A simple but searching test can be made by any one who will pin a sheet of newspaper tight against the wall, focus, and expose a plate. To examine the ground-glass is not sufficient. A

reliable test can be made only by exposing a plate. Care must be taken, however, to place the back and front of the camera accurately parallel with the surface to be copied, or the negative cannot be sharply defined throughout. The finer the lens the more sensitive it is to such error. A perfect anastigmat properly placed forms a perfectly flat image.

851. **How to Focus.**—Most views contain objects at different distances from the camera, which cannot all be focused perfectly at once. One object gains in sharpness at the expense of another.

852. To secure the sharpest possible definition of the entire view is not, as some suppose, one of the most simple operations. The photographer who looks chiefly at the center of the screen, because it is easiest, and focuses to get sharpness there, lacks either proper interest in his work or proper knowledge of how to perform it. When he finds only the center of his photograph is sharp, and sees the deficiency elsewhere, he frequently exemplifies that old proverb: "A bad workman blames his tools." The wise photographer will, therefore, learn the secret of placing the ground-glass (in cameras where the ground-glass is moved instead of the lens-board) where it gives a just division of sharpness among the principal objects in view.

853. Requests are made daily for lenses described as "fast anastigmats to cut near and distant objects sharp simultaneously." While light travels in straight lines, no such lens can do this fully, though you may be told otherwise by salesmen and by lens makers. Even the human eye makes no such attempt.

854. It should be clearly understood that *depth of focus, with any given stop, is alike in all lenses of equal focal length, regardless of their construction. Depth can be increased only by using a smaller aperture, or by choosing a more suitable focal length.*

855. The confusion partly arises because a lens of short focal length has more depth than one of long focus. At a given aperture the short one is better able to define the fore-

ground and far distance, simultaneously, and so is often preferred for hand cameras, notwithstanding its giving a smaller image. For studio portraiture a lens of long focus is better, because it is used farther away from the entire subject. Better perspective is thus secured, and superior definition of the near and distant portions, which from a distance appear less separated.

856. The first thing to do in order to focus sharply is to understand the principles of a lens' action; to know what a good lens can do and what it cannot do; and to deepen that understanding by experience.

857. The second thing is to learn the secret of placing the ground-glass just where it should be.

858. With a proper magnifier examine the ground-glass all over, not neglecting the corners, and find the important object which requires the shortest focus, and that requiring the longest. Note the position of the pinion-head or of the ground-glass screen when each of these objects is focused, and set the screen fairly between the two, favoring, as far as possible, the remainder of the view.

859. If only one object is to be focused, commence a series of rapid oscillations of the screen, passing each time the place of sharpest focus to equal blurring on either side. The amplitude of these movements must be gradually shortened until the screen comes to rest at the true focus. This operation may be repeated for confirmation, and under favorable circumstances the screen will come to rest within 1-100th of an inch of the same place.

CHAPTER XL.

VOIGTLANDER LENSES.

860. During many years of productive activity, Voigtländer & Sohn have not only furnished an endless number of lenses, all of the highest type of their times, commanding the highest prices of any photographic lenses on the market, but they have built up an organization and accumulated an experience in the manufacture of optical instruments which few can equal. The following data regarding Voigtländer lenses has been supplied by the manufacturers:

861. As a guarantee for the quality of lenses which we offer to the public our record of one hundred and fifty years of leadership in lens making is of particular interest and value. It is a record which is maintained by every individual instrument that leaves our works, and by every new construction which we place before our patrons. Most notable of our recent achievements is the production of two series of extra rapid lenses—the Heliar, mainly for use in the studio, and the Dynar, principally for outdoor use—both styles marvelously fine productions.

862. **Focal Length.**—The focal length of the lens determines the size in which the image of an object will be reproduced. The greater the focal length the larger the image will appear on the ground-glass, other conditions being equal. The size of the diaphragm has no influence whatever on the size of the image. The focal length is, to a certain extent, the measure of the size of a lens and of its capacity, making due allowance for the superiority of one style over another. Thus, a lens of 6 inch focal length is comparatively small, covering a small or medium picture only, while a lens of 24 inch focus will be called a large size

and would be used for making large pictures. While most manufacturers designate the different sizes of their lenses, by numbers, it is quite evident that such designation is altogether arbitrary, while the focal length carries meaning and description with it. All Voigtländer lenses have engraved upon them their focal lengths in inches, so that inferences as to the size of the image, etc., can at once be drawn, and a general comparison with other lenses instituted, without the necessity of referring to the catalogue.

863. While there are certain ideas prevalent as to the proper relations between the focal length of the lens and the size of the picture for which it is used, a most noticeable feature of the progress of photographic lens construction lies in the shortening of the focal length in comparison to the sizes of the picture produced. The latest and most perfect lens constructions are the anastigmats.

864. A fine anastigmat like the Collinear or Dynar, of say 6 inch focal length, will produce as large a picture as can be covered by ordinary rapid rectilinear lenses of 8 to 9 inch focus. Of two styles of lenses having the same aperture, and both covering the same plate, that one is the better which has the shorter focus and a greater depth of field than the longer one at full opening. A comparison of high grade lenses with the usual hand camera lenses on this score alone will at once demonstrate the superiority of the former.

865. **Speed.**—The best method of classifying lenses and the one actually adopted in practice, is based upon their power of transmitting a greater or less amount of light to the sensitive plate. This power of a lens is called its luminosity or speed, or, as will be explained later, its aperture.

866. The groups in which lenses are arranged are called *series*, and consist of a number of lenses of different focal lengths, but all of the same luminosity or speed (aperture). A lens of large luminosity (high speed) will produce a fully exposed picture in less time than a lens of less luminosity or speed, and this is a matter of great importance in instantaneous work, or in a case where the light is poor. Every photographic lens is provided with a mechanical device,

by which the quantity of light passing through it to the plate (its speed) can be regulated. This device is called the diaphragm, and is of metal construction having an opening or aperture. The usual form is the iris diaphragm, consisting of a set of thin movable blades capable of forming various sized circular openings. The iris diaphragm is almost universally used, the only exception being in photo-mechanical work where a large variety of openings is not essential, and where for special reasons it is also desirable to use various shaped openings other than circular. In this case the diaphragm consists of separate metal plates, with fixed opening, and is introduced in the lens through a slot in the lens mount, and known as Waterhouse stops.

867. The ratio between the effective aperture and the focal length is known as the "relative aperture," or more commonly as the "speed" or "rapidity" of the lens. When speaking of the speed of a lens the greatest speed is always meant—that speed which corresponds to the largest opening of the diaphragm.

868. In a great many lenses, reducing or increasing the size of the diaphragm opening introduces a slight change in the focus and makes it necessary to focus the picture with the stop with which it is to be taken. It may be in place to mention here, that our lenses have no variation in focus, whatever the diaphragm used. Focus may be taken at full opening, with the light at its brightest, and the lens then stopped down to the desired opening, giving the greater depth of focus. ✓

869. **Symmetrical Lenses.**—Lenses are frequently classified as symmetrical and non-symmetrical. The symmetrical, or double lens, consists of two equal halves, symmetrically arranged with a diaphragm between them, each half of which can be used by itself as a complete lens. In the non-symmetrical lenses the separate parts cannot be used independently, but must be used in combination as a whole. Of our different lenses the Collinears are the best type of symmetrical lenses. Each combination or half of a Collinear lens can be employed as an individual or complete lens by

itself. It can, furthermore, be united with half of any other Collinear lens of different focus, in the same series. The combination of these two halves will produce a perfect lens of a still different focus. In this manner so called sets of lenses possessing a great variety of focal lengths are formed.

870. Voigtländer Euryscopes, likewise, are symmetrical lenses.

871. **Unsymmetrical Lenses.**—Unsymmetrical lenses, the single parts of which cannot be used independently, are Voigtländer's Heliar, Dynar and Portrait Lenses IA and I. These cannot be divided into halves or parts, but must always be used as complete lenses exactly as furnished. Preference will naturally be given the symmetrical lenses, on account of this quality of symmetry and the resulting interchangeability of lens halves.

872. **Depth of Focus.**—If an object at a certain distance from the camera is sharply focused with a lens possessing speed, for instance, a Collinear Series III., working at f.6.8, it will be noticed that objects, both those which lie in front of and those lying behind the object focused upon, are less sharply reproduced on the ground-glass. It must be born in mind that every optical instrument can only fulfill such conditions as are not contrary to the laws of nature. Contradictory demands are often made upon instruments by photographers. We will mention as an example of requirements which it is absolutely impossible to fulfill at the same time, the frequent requests to furnish a lens which while possessing great intensity of light or rapidity also possesses a wide flat field and great depth of focus. As a matter of fact, it is unavoidably necessary in increasing the capability of a lens in the direction of rapidity, to neglect other conditions, such as depth of field and covering power.

873. It is apparent that a lens at a large opening does not reproduce with perfect sharpness all the objects contained in a certain space, but only those lying in a certain plane. The more the diaphragm opening is reduced in size the deeper apparently becomes the range of sharpness and the more distinct the reproduction of the various ob-

jects at varying distances. By stopping down, therefore, the lens gains a greater depth of field.

874. If, without changing the position of the camera, the Collinear at full aperture of $f.6.8$ be replaced by a Heliar of the same focal length, but with aperture of $f.4.5$, the depth will be found to have become less. But if the Heliar lens be stopped down to $f.6.8$, it will be seen that the depth is exactly the same as that produced by the Collinear working at $f.6.8$. This experiment merely proves the truth of the following physical law :

875. Under equal conditions of focal length and distance from the objects, the depth of field of a lens depends upon its aperture, and does not depend upon the type of the lens; it is impossible to increase the depth of the lens without decreasing the diaphragm opening, which means decreasing its luminosity—its speed.

876. The question often arises, how far may an object be from the point of sharp focus and still be fairly sharp itself? In this respect it is possible to lay down certain rules which generally lead to satisfactory results.

877. Let us suppose that a lens is focused on a very small luminous object, the image of which on the ground-glass is a point. If we move the ground-glass either away from or toward the lens the point widens in either case to a small circle or disk. As the ground-glass must be set farther away from the lens when the object is nearer and closer to the lens, it follows that if we focus sharply on any one point the images of the nearer points, as well as farther points, are drawn out into small circles or disks. These are called the diffusion disks, and are the measure for the indistinctness which results from the shifting of the ground-glass out of the plane of sharp focus, and for the indistinctness of objects which are not at the distance focused upon. It being impossible to focus sharply on all points, at all distances, at one and the same time, the focus must be so chosen that it will produce the best general effect in each case.

878. This question of focusing and the extent of permissible indistinctness in depth need only be discussed for

lenses of short focal length, such as those to hand and small tripod cameras. Practice teaches that with lenses having focal lengths of from 4 to 10 inches, the diameter of the diffusion disk may be 1-200 of an inch and the picture still appear sharp to the eye. This figure has been arrived at merely by experience, and covers the general average of cases. At times it may be increased and at others it may have to be reduced, according to requirements. In a great many cases it will be safe to admit of an enlargement of the diffusion disk even to 1-100 of an inch, without causing any objectionable unsharpness. Depth may, therefore, be defined as that distance on either side of a sharply focused object, within which the image of a point enlarges into a small disk of from 1-100 to 1-200 of an inch. The depth is greater in a backward direction than toward the lens, and with equal relative apertures the depth is greater in lenses of shorter focal lengths than with larger ones.

879. Theoretically, lack of sharpness in certain parts of the picture is a great drawback. In reality, however, if we eliminate special cases, such as architectural photography, photo-grammetrical, tele-photographs, etc., the lack of sharpness in depth is of no great importance in lenses of great rapidity. On the contrary, the very lack of sharpness is frequently an aid in the making of pleasing pictures, helping, as it does, to tone down the minute definition which is so objectionable in many photographs, and giving the atmospheric effect so necessary in the rendition of a pictorial subject. It may even be said that lenses of great rapidity are a valuable aid in the distribution of distinctness and indistinctness in a picture, and in imparting to it a feeling of depth, roundness and life, in contrast to the monotony of a photograph possessing extreme definition. Always use the largest possible aperture consistent with general effect—do not stop down unnecessarily.

880. According to what has just been said, the only proper way of testing a lens for sharpness of definition is to examine a picture of an object located in a plane, the latter being vertical to the axis of a lens. This will eliminate in-

distinctness of depth and permit of correct examination of the sharpness of the image focused upon. Do not draw the conclusion that the lens will not give definition because it fails to produce the subject, foreground and background sharp at the same time.

881. **Astigmatism.**—We divide our lenses into anastigmats and non-anastigmats. In view of the great superiority of anastigmats, we should explain that we continue to make and list non-anastigmat lenses, such as the Unsymmetrical Portrait Series I. and Series IA, and the two series of Euryscopes only for very excellent reasons, justified by an experience of many years. The Series I and IA are used exclusively for portrait photography at a very short distance where, in view of their exceedingly small depth, anastigmat flatness of field is of no advantage in comparison with the advantage of their high speed. The two series of Euryscope are of exceedingly simple construction, and at so low a range of price, that it is desirable, for these reasons, to retain them in our list. With the exception of those mentioned, all our lenses are perfect anastigmats.

882. In outward appearance the non-anastigmats are distinguished by their much greater length. The field of sharp definition of the non-anastigmats is very much smaller than that of anastigmats of equal focal length and aperture, and even when used with a very small diaphragm their work still bears no comparison with that of the fully corrected lenses.

883. In selecting a lens the amateur photographer should consider only the anastigmats. In the first place, because he requires a large sharp image at full aperture, and in the second place, because the unwieldy shape and size of the non-anastigmats would render instantaneous work impossible.

884. In our list of lenses the size of the image is always mentioned in connection with each lens. In the case of anastigmats these plate sizes are covered to the very edge with absolute sharpness and perfect marginal definition. In

the case of non-anastigmats the sizes indicated are those which general usage among photographers has adopted.

885. **Angle of View.**—Stopping down the lens increases the sharpness at the edges of the plate and gives the lens the power to cover sharply a larger plate than that which it covers at full opening, and it is on this larger plate that the greater angle of view is obtained. On the other hand, the increase of sharpness resulting from stopping down has its limits. Briefly stated, the limit lies between the openings f.64 and f.128. We advise against the use of diaphragms smaller than f.64. In fact, in several of our lenses we do not extend the scale below f.45 or even f.32.

886. **Choice of Lens.**—The choice of a photographic lens involves, in accordance with the foregoing, a decision as to the angle of view and focal length to be selected. It is a generally conceded fact, that for artistic results an angle of 45 degrees should not be exceeded. This would necessitate the use of an 8 inch lens on a 4 x 5 plate, which seems rather long. There is no doubt that the work of the painter seldom comprises a larger angle, and that this produces the most pleasing proportion between the foreground and background. For portrait photography, likewise, a lens of 45 degrees has the advantage of rendering the figure of the sitter in its proper relative proportions. In many cases, therefore, the lens of small angle and long focus is desirable, but there are many other circumstances influencing the choice, and the photographer will have to decide for himself according to the conditions surrounding his work. If the photographer makes use of a camera which permits of exact focusing, as, for instance, the "Reflex," the best results will be obtained by using a lens of long focal length. On the other hand, the shorter focal length lenses being easier to focus, are better for instantaneous exposures, in which there is little or no time for accurate focusing.

887. Landscape and group lenses used on tripod cameras should in no case be chosen with a larger angle than 55 degrees. For portrait exposures experience has demonstrated that the smallest suitable focal lengths are: for

small bust pictures 8 inches; for cabinet bust pictures, 12 inches; for Paris panels, 16 inches. In short studios, however, shorter focal length lenses frequently have to be used; for wide angle work, on the other hand, the shortest possible focal lengths can only be used.

888. Although our lenses may invariably be used for larger plates than listed to cover, we are opposed to the straining of lenses, and advise against it except where absolutely necessary to secure the greatest angle the lens is capable of producing. The mistake of straining a lens becomes only apparent when the shifting or rising front is used in connection with a lens whose focal length is small compared to the size of the plate. There occurs at once, in such cases, a loss of light toward the edges, and very often the plate is not completely covered. If, for no other reason than this, a focal length should be chosen, which on a given plate would correspond to an angle of about 60 degrees for the lens working at f.6.8; an angle of 55 degrees for lens working at f.5.6, and 45 degrees for a lens working at f.4.5.

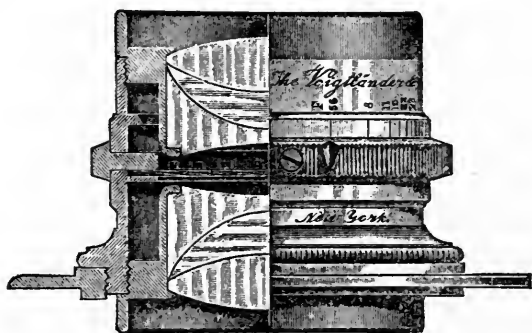

Illustration No. 76

889. **Voigtländer's Collinears.**—Collinear lenses are a new type of anastigmatic doublets, consisting of two symmetrical anastigmatic halves. Each of these halves is made up of three glasses, the contiguous surfaces of which are permanently cemented together. The new Jena glass is used in the construction of Collinear lenses. The outside

glasses of the combinations are of a durable, hard quality not effected by the atmosphere. The lenses have no air spaces which might introduce false reflections. The sharpness of definition of the image produced with the Collinear lenses is remarkable for detail and precision, and is the same on the edges of the plate as in the center. The covering power and the flatness of field are unexcelled.

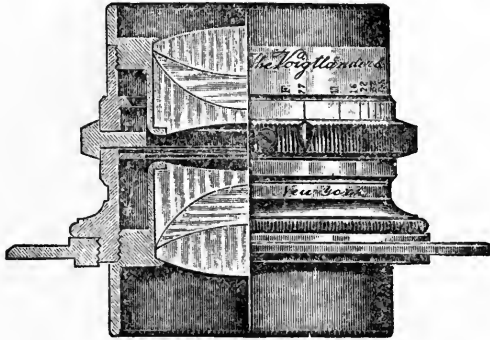

Illustration No. 77

890. Collinear lenses are achromatic, rectilinear and free from distortion. Their speed, especially of the Series II., is of a very high order. The lenses of this series are the most rapid symmetrical anastigmats. They work with an aperture of $f.5.6$, and are suitable for focal plane shutter work. (See Illustration No. 76.) The Series III., working with an aperture of $f.6.8$, is also a very rapid lens, and is a true universal lens to be highly recommended for all general work. The rear combination of a Collinear lens can be used alone as a landscape lens, giving double the focal length of the complete instrument. The general appearance of this lens, also its optical construction, is shown in Illustration No. 77.

891. **Voigtländer's Dynar.**—The Dynar is an entirely new lens of recent construction, the advantages and attractive features of which are its compactness and lightness, its speed, its careful anastigmatic corrections, and its comparatively low cost. The Dynar consists of five glasses, two

sets of each firmly cemented, and the fifth glass placed separately between the two sets. This construction is entirely different from the symmetrical form of the Collinear lens.

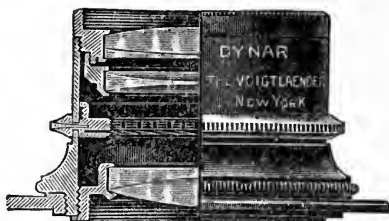

Illustration No. 78

892. Owing to its compactness and speed the Dynar is highly recommended for hand and pocket cameras—Kodak, Hawkeyes, Centuries, Ansco's, Premos, etc. The dimensions of the lens mounts are such that they will fit directly into the standard sizes of modern shutters. The speed of the Dynar is $f.6$, which means that at this aperture



Illustration No. 79

it is one and a half times as rapid as a lens at $f.8$. The speed is sufficient for all between-the-lens shutters and for focal plane shutters. This lens is thoroughly corrected—achromatic, rectilinear and anastigmatic; the field is flat, the

definition excellent. Although primarily constructed to be a hand camera lens, the Dynar will be found available for producing excellent indoor and outdoor work, views, groups, mechanical work, etc. The optical construction of the lens will be clearly seen on referring to Illustration No. 78.

893. **Collinear and Dynar Lens Cells.**—Both the Collinear and Dynar lenses may be procured in the cells alone for folding pocket kodaks. (See Illustration No. 79.) These lens cells may be screwed, without any fitting, into Automatic or Volute shutters. Any one can send for a set of these cells, and without any assistance remove his original lens cells and replace them with the high grade Collinear or Dynar cells.

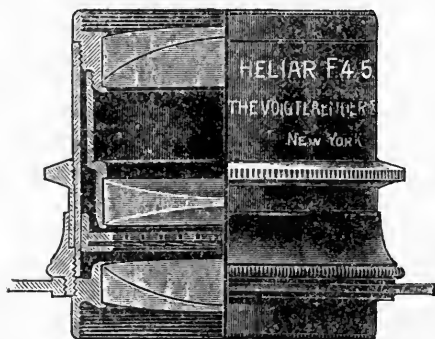

Illustration No. 80

894. **Voigtländer's Heliar.**—This lens, working with a speed of $f.4.5$, is one of the most suitable all around lenses on the market. It is particularly adapted to portrait work, yet cannot be excelled for high speed instantaneous exposures with focal plane shutters, enlarging, projection and telephoto work. The lens cells are mounted in two styles of mountings, as shown in Illustrations No. 80 and No. 84. The hand camera mount is used for the first four sizes, and the portrait mount used for sizes 5 to 9. (The advantages of this lens for portrait work are thoroughly explained in the Chapter on Portrait Lenses.) The Heliar lens may be attached to the Graflex, Reflex, and other high speed cameras, supplied with a focal plane shutter.

895. Telephoto work requires a quick and accurate positive lens. Either the Heliar or Collinear Series II. lens used as a positive and combined with a Voigtländer telephoto attachment forms undoubtedly the quickest telephoto constructions obtainable. (The telephoto attachment is described in the Chapter on Telephoto Lenses.) For enlarging and projecting the speed of the Heliar and Collinear lenses and their sharpness of definition are highly desirable qualities.

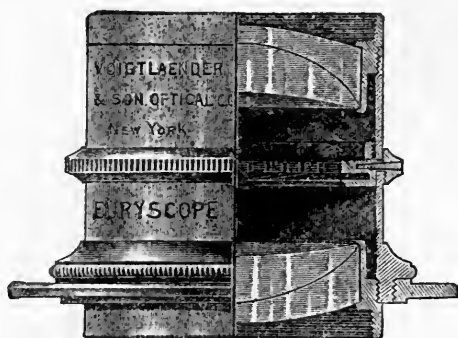

Illustration No. 81

896. **Voigtländer's Euryscope.**—The Euryscope lenses are intended for the making of portraits. (The Portrait Euryscope is described in the Chapter on Portrait Lenses.) The Extra Rapid Euryscope (See Illustration No. 81) is by far the most popular of the various series of Euryscopes, owing to the fact that it is an all around lens for both portraits and groups. It has a medium speed, the aperture being $f.7$. Its comparatively flat field with an angle of about 55 degrees makes it especially suitable for group work, and it is frequently preferred, on account of its depth, to the more rapid Series III. Portrait Euryscope or the Heliar. The construction is a symmetrical one, the lenses are of Jena glass, and the iris diaphragm is furnished in all lenses of this series.

CHAPTER XLI.

PORTRAIT LENSES.

897. The slowness of the average achromatic lens and its uncorrected defect of curvature renders it of little use for interior portrait work. The principal requirement of an ideal portrait lens is, that the lens be one of long focus and work with a large aperture, thus giving greater speed. Its construction should be such as to enable it to give perfect definition over a limited field (18 degrees), at f.4 or U. S. No. 1, with complete coincidence of the chemical and visual foci. For large portrait work (plates over 5 x 7 inches), however, the portrait lens has not the advantages of the modern anastigmat, because its depth of focus at f.4 is so slight it is necessary to stop the lens down to a smaller aperture than is necessary when employing the anastigmat.

898. The principal type of portrait lens was invented by Petzval, in 1841, and was manufactured by Voigtländer. This lens remains at the present time the general principle of construction of all portrait lenses.

899. **Dallmeyer Patent Portrait Lenses.**—The Dallmeyer Patent Portrait lenses are too well known to need a long introduction. Ever since they were introduced, in 1866, they have held their supremacy for studio portraiture. At the present time there is a strong tendency toward using anastigmat lenses for portrait work, but for studio portraiture, pure and simple, the Dallmeyer Portrait lens possesses an indefinable “something” which places them ahead of any other type. For outside work the anastigmat lens is excellent, and in many cases an absolute necessity, if the best results are to be produced.

900. The Dallmeyer Lenses are constructed on a dif-

ferent principle from the old or Petzval type of portrait lenses, and excel them in sharpness of definition, in freedom from distortion and flare, and in equality of illumination; while, in addition to this, they afford the means, by the simple turn of a screw, of obtaining greater equality or depth of definition. (See Illustration No. 82, Page 379.)

901. The construction of the lens is such that, with its cells all screwed home, it produces the sharpest possible picture of objects situated in one plane. Then, by unscrewing the barrel a turn, or parts of a turn, the previous intensely sharp definition becomes modified; i. e., the contrast of excessive sharpness in one plane, compared with want of sharpness in other planes, is balanced, producing the impression of a general distribution or depth of focus; and this in proportion to the amount of unscrewing. Nothing has been sacrificed in securing this *new power*, and it can be used or not, at the *will* of the operator, who will rapidly become proficient in judging what is necessary to produce any desired effect.

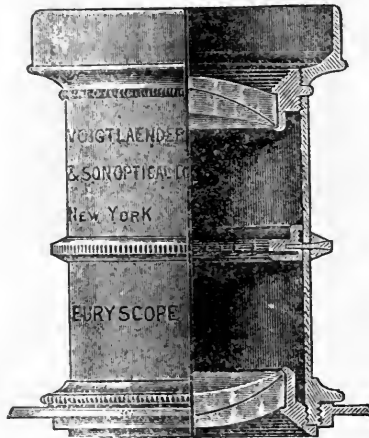

Illustration No. 83

902. **Manner of Diffusing.**—When it is desired to separate the lens combination in order to secure more definition, you should first unscrew the lens and then focus after-

ward. The separating of the individual lenses alters the focal point, and it is, therefore, essential that you accurately focus after the desired amount of diffusion has been secured.

903. **Voigtländer's Portrait Euryscopes** have been favorably known for their excellence, among photographers, for more than thirty years. Recently they have been improved by slightly modifying the calculations to conform to the peculiarities of the new Jena glass, from which they are now constructed, the most suitable grade of this glass being employed for the manufacture of the Euryscopes. The Portrait Euryscope, Series III., is distinguished for rapidity under the skylight and for artistic softness. It is intended only for heads and busts. (See Illustration No. 83.)

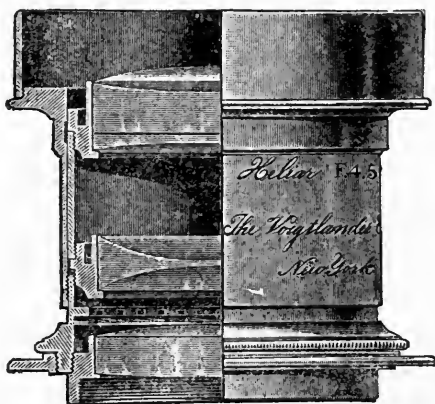

Illustration No. 84

904. **Voigtländer's Heliar Lens.**—This lens, which is suitable for portraiture, heads, busts, full lengths, and groups, is also made in a special mount suitable for high speed instantaneous work with the focal plane shutter for enlarging projections and telephoto work. This lens is the type of portrait anastigmats which are, to a great extent, taking the place of the old style portrait lenses. The Heliar lens is a carefully corrected high speed anastigmat lens with a medium angle of view. The difficult problem of obtaining

high speed, without sacrificing optical perfection, is solved in this lens. The Heliar has a perfectly flat field and very sharp definition. It possesses great brilliancy of image, on account of the entire absence of so-called "coma." "Coma" produces gray, flat images, while Heliar images sparkle with brilliancy. The combination of all these qualities explains the wide range of usefulness of the Heliar lens. (See Illustration No. 84.)

905. The usual trouble experienced with a portrait lens is that with full opening it will cut only heads and busts, but not full length figures and groups. For these it has not the necessary flat field—it requires stopping down, and this means loss of speed. The Heliar lens does not re-

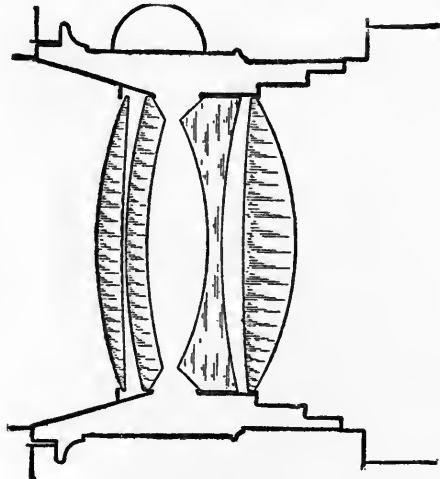

Illustration No. 86

quire stopping down, except where more than usual depth is needed.

906. The lens consists of five glasses, comparatively thin, so as to transmit a maximum amount of light, a single glass being placed between two sets of two glasses securely cemented together. The body of the lens is largely made of aluminum, so as to reduce its weight. The iris diaphragm is

placed between the middle and the rear lens, as will be seen on referring to Illustration No. 84.

907. To many professional portrait workers the introduction of the anastigmat type of lens, with its high optical corrections, has not appealed, on account of the sharpness of the image, which reproduces the human features and the texture of the skin with too great detail. This tends to hardness and gives an unpleasant effect, especially where the portrait is of comparatively small size.

908. **Bausch & Lomb Portrait Lenses.**—The portrait lenses manufactured by the Bausch & Lomb Optical Company are especially adapted to all around studio work. In Illustration No. 85 is shown the mounting for the regular Bausch & Lomb Portrait Lens, while in Illustration No. 86 is given a sectional view of the Bausch & Lomb-Zeiss Portrait Unar, which lens works at an aperture of $f.4.5$. It is a portrait objective giving any amount of softness or crispness desired, and although an anastigmat lens, the diffusing attachment with which it is fitted enables one to secure excellent portrait effects without the harsh wiriness common to the average anastigmat lens. For full figures and group work this instrument is unexcelled, while for landscapes, interiors, copying and enlarging it is practically the equal of any lens on the market. Most lenses are better for some one purpose than for others, but with the Portrait Unar the whole range may be said to be covered equally well. It is quite true that this lens is somewhat expensive for the average worker, but where the results are taken into consideration it is money well invested.

909. **The Diffusing System.**—In the older types of portrait lenses the diffusing system is applied, but to adjust this system it has been necessary to remove the lens from the camera, or to remove the ground-glass, in order to get at the rear of the lens. Either of these methods consumes a considerable amount of time and does not permit of accurate adjustment of the amount of diffusion to the subject.

910. The later types of portrait lenses manufactured by the Bausch & Lomb Optical Company have a diffusing

system, which can be operated by an adjusting knob which projects outside the lens barrel, on which a scale of values is engraved. In Illustration No. 87 is shown a sectional view through the Bausch & Lomb Portrait lens, giving an excellent idea of the optical and mechanical construction. The dotted lines show the position of the front lens of the diffusing system for greatest diffusion. This construction differs radically from that of other lenses, the front lens be-

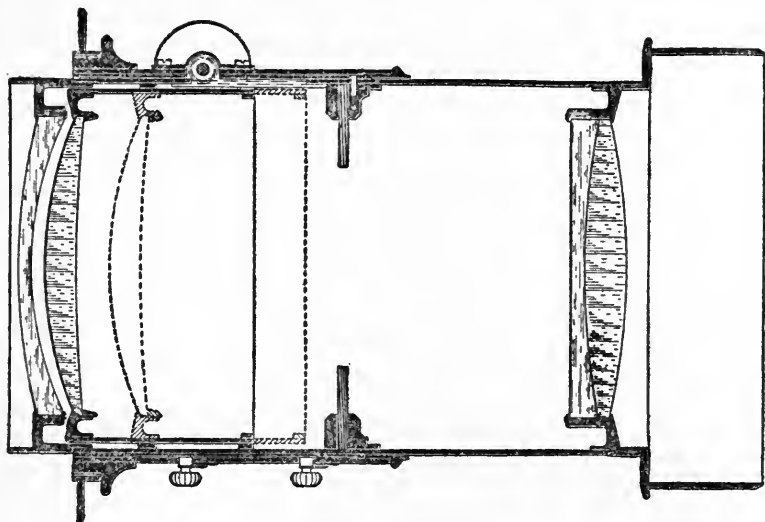

Illustration No. 87

ing movable instead of the rear one. By this improved construction any desired degree of diffusion of focus is obtained without disturbing the optical correction of the lens, as is the case of the rear lenses when the systems are movable.

911. Speed of Portrait Lenses.—The speed of portrait lenses of the same equivalent focal length varies directly with the diameter of the lens. It is, therefore, possible to preserve approximately the same focal lengths in portrait lenses, and obtain greater speed by simply increasing the diameter of the lens. This increase in diameter very materially increases the cost. The photographer will, however,



Illustration No. 82
Dallmeyer Portrait Lens
See Paragraph No. 900



Illustration No. 85
Mounting for Bausch and Lomb Portrait Lenses
See Paragraph No. 908



Illustration No. 88
NORMAL PERSPECTIVE
Made with Long Focus Lens.
Distance, Lens to Figure,
Eighteen Feet
See Paragraph No. 913

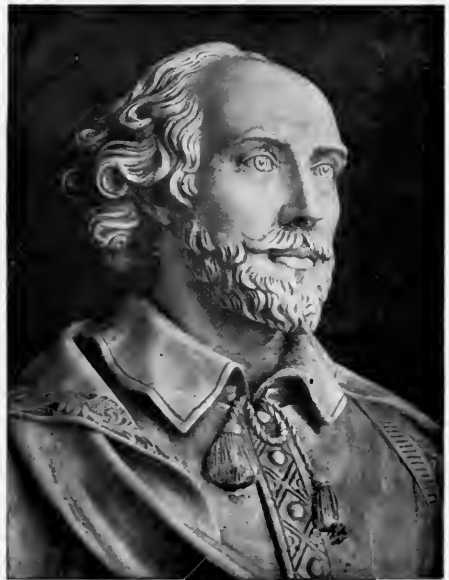

Illustration No. 89
DISTORTED PERSPECTIVE
Made with Short Focus Lens,
Distance, Lens to Figure,
Eighteen Inches
See Paragraph No. 913

find it very much to his advantage, especially considering the present tendency in photographic portraiture, to purchase as wide a lens as he can afford. It is always possible, by modifying the studio light or stopping down the light, to retard the exposure as much as it is desired when one has an extremely rapid lens. With a slow acting lens, however, it is quite impossible to obtain satisfactory exposures excepting with strong light, if one is to preserve the rapidly changing expressions of the countenance under normal conditions; or to secure well defined pictures of infants or children, especially in late afternoon work. The possession of a rapid lens adds several hours to the photographer's working day.

912. It is also possible to get good results in gray and cloudy weather. Rembrandt and other similar forms of lighting, especially the full shadow lightings, render it imperative to have a lens of the greatest speed, so that when the amount of light falling upon the features is reduced, the exposure may be brief.

913. **Distorted Perspectives.**—Few photographers realize the disadvantages accompanying the use of a lens having a short focal length. The two illustrations (Illustrations Nos. 88 and 89) are designed to show the results which follow the use of a lens of too short focus. The extreme cases have been chosen to more clearly illustrate the prin-

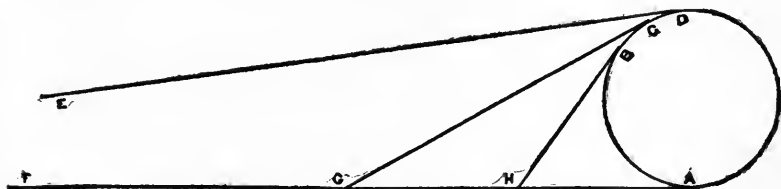

Illustration No. 90
Why a Short Focus Lens Distorts

ciple, but it clearly demonstrates the effect of a lens including too wide an angle, or, in other words, being of too short focal length. Quite often the photographer not only fails to please, but actually loses orders through this very

fault in work submitted to the public. The sitter may not know *why* the fault exists, but he knows that it *does exist*, and does not like it.

914. The diagram (Illustration No. 90) shows why a short focus lens distorts. If the lines E D and F A represent the rays of light from the surface of a spherical body to a long focus lens, it would be seen that light from approximately one-half the surface of the object represented by arc A D reaches the lens. If the lens is of a shorter focus, necessitating that it be placed at G, less than one-half the surface, or the arc C A, will be included in the image, while at the position H only the arc B A will be seen. At the same time the image has been growing larger as we approach the object, so that now the small arc B A is spread over an area several times greater than the semi-circle D A included by the long focus lens.

915. The photograph represented in Illustration No. 88 shows normal perspective and was made with a long focus lens, the distance from the lens to the figure being 18 feet. In the distorted photograph (Illustration No. 89) the lens was one of short focus, and the distance from the figure to the lens was 18 inches. The result in this photograph shows the extreme distortion of the features, completely changing the expression and causing a flattening of the lighting.

916. **Depth of Focus.**—While depth of focus in any lens depends upon the focal length and relative aperture, it will be found that the modern anastigmat type of portrait lenses possesses depth of focus in as great a degree as any other lens of similar focal length and aperture. With a given aperture, and at a given distance, the shorter the focal length of a lens the greater its depth of focus. It should always be remembered, however, that the closer the lens is to the sitter the less will be the depth obtained in the picture; so that the long focus lens shows more depth for large pictures.

917. Depth of focus is also obtained by stopping down the lens. In testing a portrait lens for depth of focus, the above conditions should always be borne in mind, and the

photographer should not expect a lens to do more in this respect than the physical laws, which control the formation of all images by lenses, will permit. Illustration No. 91 shows a portrait made by Dudley Hoyt, with a Bausch & Lomb Portrait lens, $f/4$ of 16 inch focal length.

918. **Care of Lens.**—Care of the photographic lens in the studio is of the utmost importance, as it may be permanently injured by carelessness or lack of knowledge of the proper care to be given.

919. Keep the surface cleaned, using a soft cloth, such as an old washed-out linen handkerchief. Dust the surface lightly at first, to remove the larger particles; then polish carefully until perfectly clean, dampening the lens by breathing upon it, if necessary. *Never use any sort of polishing material on the lens.* Never allow strong sunlight to fall upon the lens for any length of time. Protect the lenses against sudden changes of temperature as much as possible, and where moisture condenses upon them from this cause it should be immediately removed.

920. Should it be necessary to remove the lenses from their mountings to clean them, which should be done frequently, remove one at a time, clean and replace it exactly as found in the cells; otherwise the correction of the lens may be spoiled.

921. In case the lens becomes damaged accidentally, or the surface scratched or coated by the actions of the chemicals in the air of the studio, it should be returned to the makers for repairs.



By Dudley Hoyt

Illustration No. 91
Made with Bausch and Lomb Portrait Lens f 4, 16 in. Focus
See Paragraph No. 917

CHAPTER XLII.

TELEPHOTOGRAPHY.

922. The size of the photographic image of an object depends first upon the size of the object; second, on its distance from the lens; and third, on the focal length of the lens employed.

923. The size of the object to be photographed is unalterable; if, however, it is wished to take different sized pictures of it with one and the same positive lens, then the object must be photographed at different distances. If the distance from an object is considerable, then pictures of different sizes of this object can only be taken by employing lenses of different focal length.

924. The size, weight and price of a complete photographic outfit grow with the increasing length of focus of the lens, so that the limit is soon reached beyond which the focal length cannot be considerably extended. This difficulty is readily overcome by substituting a telephoto lens, when it is no longer necessary to alter the position, nor to use lenses of different focal lengths, to obtain pictures of different sizes of one and the same object, from the same standpoint.

925. In the same manner as a telescope helps the human eye to see distant objects larger and clearer, so the telephoto lens, which is a *photographic* telescope, helps to increase the size of the image projected on the plate, which increase is effected by the addition of a negative lens to the positive elements of the lens in use.

926. Every possessor of a good photographic lens can convert it, by the addition of a telenegative with a teletube, into a telephoto lens, the positive lens being unaltered, and still available for ordinary use.

927. Telephoto lenses are lighter, more convenient, and less costly than positive lenses of correspondingly long focus. They give pictures of almost the same sharpness and clearness as ordinary lenses, but cover a smaller angle, and have less rapidity, the latter becoming less the greater the magnification obtained. On the other hand, by using the telephoto lens pictures which require a long focus lens can be taken with small cameras with short bellows, an advantage unobtainable by any other method.

928. With a telephoto attachment, therefore, we obtain the advantages of a lens of long-equivalent focus without the need of a corresponding increase of bellows extension. As will be seen later, this equivalent focus, and therefore the magnification, can be varied. By the use of a telephoto lens objects situated at a remote distance or, from their position, inaccessible to the photographer with his ordinary outfit, can be faithfully recorded without difficulty. With it can be photographed the capitals of columns, carving or inscriptions, for which the camera without the attachment would be useless. The landscape worker, without moving his camera, can determine the amount of subject he will include upon his plate, can take mountain ranges, inaccessible peaks, and many a gem of scenery, which from the nature of its surroundings, can only be taken from a distance. The naturalist, perhaps, is even more indebted to

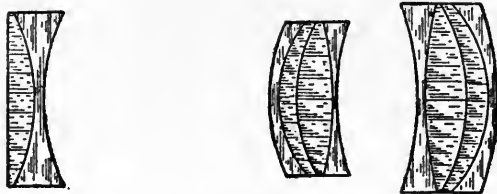

Illustration No. 92

the telephoto lens, for by its means large pictures of the most timid animals can be taken. Not only is the telephoto lens of value for distant objects, but for subjects near at hand it is equally useful, as it is only by use of the telephoto lens that objects can be reproduced in anything like natural

sizes with due regard to their proportion, and without distortion or exaggerated perspective.

929. There is another important advantage of the

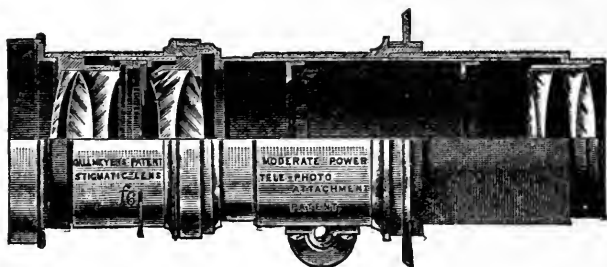

Illustration No. 95

telephoto lens. If we have to reproduce an object in exactly full size, we, of course, measure our image on the screen, and compare this measure with the original. If we measure the image given by the positive lens on the screen, we find that only the parts lying in a certain plane are correct, those lying in other planes being either larger or smaller than the original. In the image taken with a telephoto lens we can

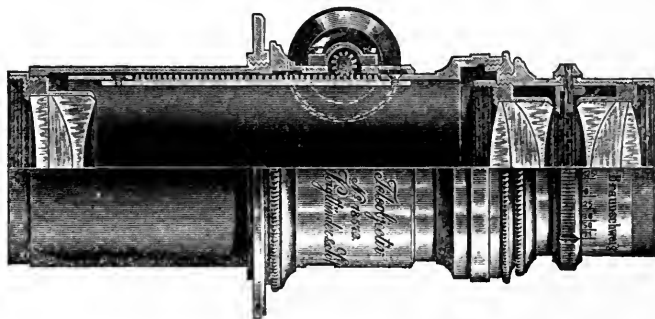

Illustration No. 96
Voigtlander Telephoto Lens

compare the size of any part of the image with the original, which not only facilitates the working considerably, but insures a reproduction of exactly the same dimensions.

930. The telephoto lens is essentially a negative lens

adjusted in a long tube, which latter is attached to the front board of the camera, the opposite end being threaded to receive the photographic lens, which latter is termed a positive lens. The adjustable tube usually has a scale to indicate magnifications. In Illustration No. 92 is shown the optical construction of the Bausch & Lomb telephoto attachment, while Illustration No. 93 shows the exterior view of this instrument. Illustration No. 94 shows the Goerz telephoto lens and mount, in the front of which has been fastened the positive lens. The Dallmeyer telephoto lens is shown in Illustration No. 95, while Illustration No. 96 shows the Voigtländer telephoto instrument.

931. A telephoto optical demonstration is shown in Illustration No. 97. This picture was taken with a Bausch & Lomb-Zeiss Protar, Series VIIA, with a high power telephoto attachment magnifying $5\frac{1}{2}$ diameters. The small picture in the upper corner shows the same scene as it appears in a photograph made with the same lens without the telephoto attachment.

932. The following table will give you an idea of the distance required for certain size plates from the front board of the camera to the ground-glass, for various magnifications:

933.

DISTANCE FROM THE FRONT BOARD TO THE GROUND GLASS.							
Size	Equiv- alent Focus of Photo Lens	Magnification Resulting Focus when used with Tele-Photo Attachment					
		3	4	5	6	7	8
Inches	Inches	Inches	Inches	Inches	Inches	Inches	Inches
4 x 5	$6\frac{1}{2}$	$6\frac{3}{8}$	$9\frac{5}{8}$	$12\frac{7}{8}$	$16\frac{1}{8}$	$19\frac{3}{8}$	$22\frac{5}{8}$
5 x 8	$8\frac{1}{4}$	$8\frac{1}{2}$	13	$17\frac{1}{2}$	22	$26\frac{1}{2}$	31
$6\frac{1}{2}$ x $8\frac{1}{2}$	$11\frac{1}{2}$	$10\frac{1}{2}$	$16\frac{1}{2}$	$22\frac{1}{2}$	$28\frac{1}{2}$	$34\frac{1}{2}$	$40\frac{1}{2}$
8 x 10	$13\frac{1}{2}$	$13\frac{1}{2}$	$20\frac{1}{2}$	$27\frac{1}{2}$	$34\frac{1}{2}$	$41\frac{1}{2}$	$48\frac{1}{2}$

934. **To Find Magnification of a Telephoto System.**—To find the magnification of a telephoto system, divide the



Illustration No. 93—B. & L. Telephoto Lens
See Paragraph No. 930



Illustration No. 94—Goerz Telephoto Lens
See Paragraph No. 930



Illustration No. 100—B. & L. Projection Lens
See Paragraph No. 946

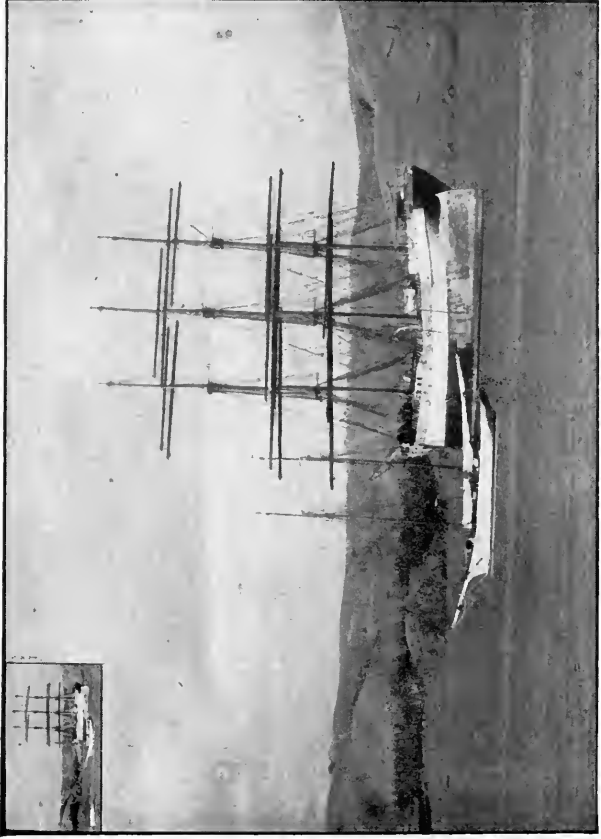

Illustration No. 97—Telephoto Demonstration
See Paragraph No. 931

distance of the negative lens from the ground-glass by the focal length of the negative lens, and add 1. Expressed in formula form:

$$M = \frac{E}{f_2} + 1$$

Thus, if the distance from the negative lens to the ground-glass is 12 inches, and the focus of the negative lens 3 inches, we have:

$$M = \frac{12}{3} + 1 = 5.$$

935. **Exposure in Telephotography.**—The greater the magnification, the less the rapidity of the telephoto lens. To find the speed or F. number of the telephoto system, divide the F. number of the positive lens by the magnification. Thus, if the positive is being worked at f.11 with 4 times magnification, the real rapidity is f.44, and exposure must be given on this basis.

936. The exposures obtained by above rule are indicative, and not imperative, and are often greatly modified by the condition of the atmosphere. As a rule an exposure shorter by about one-third than the theoretical one will be found correct in the United States.

CHAPTER XLIII.

PROJECTING AND ENLARGING.

By W. L. Patterson

Of the Bausch & Lomb Optical Co., Rochester, N. Y.

937. The optical principles of Projecting and Enlarging are practically the same.

938. **Illuminant.**—In the matter of illuminants for projection we might put aside all lights excepting the electric arc and possibly the lime light. We use an electric arc with carbons at 90 degrees; for alternating current an arrangement with less angle would be better. Fair work in enlarging can be done at short distances with the Welsbach gas lamp, because the sensitive paper is capable of taking up an image which would not be satisfactory for projection purposes.

939. **Adjustment of Arc.**—The electric lamp must always be adjusted with the arc central to the axis of the optical parts, both in projecting and enlarging. If the arc is not central with the condensers there is unevenness in the illumination of the field. A great deal depends on the distance between the rear condenser and the arc. If we bring the arc close to the condenser with the lens now in the lantern before us, we can quickly see that a great amount of red color is introduced into the margin of the field. If we put the arc too far away from the condensers we get a blue margin in the field, therefore, we have one correct point where the field is fairly well illuminated, and that has been found to be, from general experience, the point where the converging rays from the condenser cross in the projection

lens, i. e. the light has to be so placed from the condenser as to bring the focus of light or crossing of rays to where the axis of the projection or enlarging lens is situated. (Mr. Pancoast suggested that smoke from a cigar or other source would render the rays visible.) This brings us to a ques-

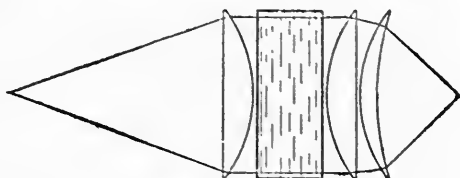

Illustration No. 98

tion which we are often asked, that is, what should be the relative position of lamp to lens? This is not constant for all lenses; it will vary with each and every lens and it will vary with the same lens, because the position of the lens with relation to the image changes as the object changes with relation to the lens, and for that reason you should adjust the arc for various distances and enlargements, and also for various lenses. Care should also be taken to keep the lamp in proper adjustment, if a hand feed form, for if the arc flames, it is too long, i. e.—carbons too far apart. If the arc hisses with direct current, the carbons are too close. Alternating current invariably produces a buzzing noise.

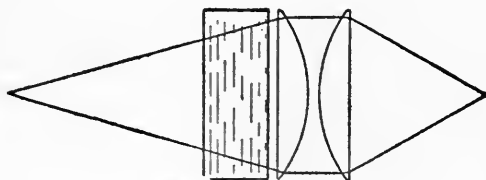

Illustration No. 99

940. **Triple System Condenser.**—In our projection apparatus we have introduced a triple condenser system, Illustration No. 98, consisting of one meniscus and two plano-convex lenses. This system has many advantages over the

double condenser system, Illustration No. 99. First, the angle is greater because the arc is nearer the lens and there is thus collected from it a larger cone of rays. The beams are rendered parallel by the two rear lenses, in the double condenser system by the one rear lens only. Second, the meniscus being the rear lens, the arc is at practically a uniform distance from all parts of the rear surface of this lens and there is much less loss of light by reflection. Third, the lenses are thinner and will expand and contract more readily with the heat and cold than the thicker lenses and are therefore less liable to crack. Fourth, we can without disadvantage place a water tank between the lenses of the condenser system to cut off the heat rays, not only for lantern slide projection, but also and principally for microscopical projection. This is also valuable in bromide work because the heat from an arc light is often intense, and when a negative is valuable it is well to use some precaution to prevent injury, and also to protect valuable photographic lenses. In the double condenser system the tank as ordinarily applied in microscopical projection is impractical for use in the projection of lantern slides because, as can be seen from Illustration No. 99, so large a part of the field is cut off.

941. The foci of single condensers are usually as follows:

Diameter Inches	Focus Inches	Diameter Inches	Focus Inches
4	5½ or 6½	7	12
4	5½ or 6½	8	12
4½	5½ or 6½	9	14
4½	5½ or 6½	10	15
5	6	12	18
5½	8	14	21
6	10		
6½	10		

942. **Foci of Condensers.**—When two are combined the focus is one-half that given in table, measured from center of combination. These foci are considered correct for the size of plate which the condensers will cover. Variations from these foci would mean the purchase of a variety of lenses and generally sufficient variation in cone of light can be obtained by adjusting the light to or from condensers. A ground-glass either between the condensers or between the arc and condensers diffuses the light in enlarging. A sand-blasted watch glass of large size placed between arc and condensers has been recommended by Mr. Earle. The ground-glass should not be placed near the negative as it would be in focus and therefore show in the enlargement.

943. **Enlarging.**—In the matter of photographic lenses, we have been asked several times for lenses especially corrected for bromide enlarging. The lens that will do good photographic work is suited for bromide enlarging, as well as for other work. The lens, of course, should be of good quality and have flat field and covering power sufficient for the negative which it is to enlarge. As the image is formed at a comparatively short distance from the lens the working distance is increased and therefore a somewhat larger plate can be covered but the speed is also reduced. It is better, however, to use the same focus lens as is used in making the picture. Some workers recommend the Portrait Unar for enlarging. Just as in other photographic

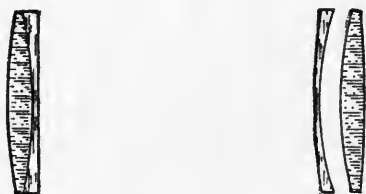

Illustration No. 101

work the better the lens the better the result, hence the anastigmat with its flatness of field, its great covering power, its even illumination, its superior correction for spherical

and chromatic aberration, gives the best possible results. Stopping down the lens produces better results, just as in other photography.

944. In the matter of projection lenses, you may have occasion to determine what focus lens is suitable for certain work. I give the formula which I use:

Let S=Size of opening slide, in inches.

D=Diameter of disc on screen, in feet.

L=Distance from lantern to screen, in feet.

F=Equivalent focal length of projection objective.

$$\text{Then } L = \frac{D \times F}{S} \qquad D = \frac{L \times S}{F} \qquad F = \frac{L \times S}{D}$$

945. Thus, if we have a hall in which we wish to work at 50 feet distance, with image on screen 10 feet square, with regular 3 inch slide, what lens shall we use?

$$F = \frac{L \times S}{D} \qquad L = 50 \qquad S = 3$$

$$D = 10 \text{ therefore } \frac{50 \times 3}{10} = 15 \text{ inches}$$

which would be the equivalent focus of lens required.

946. In Illustration No. 100 we illustrate the Bausch & Lomb Projection Lens. Illustration No. 101 gives a sectional view, showing the optical construction of this lens. This lens utilizes an exceptionally large amount of the light of the lantern and renders sharp, clear, beautifully illuminated pictures. The field is extremely flat and the illumination is uniform over the entire screen. The mounting of the lens is of superior finish, the movable tube being nicked and working in a cloth sleeve. The adjustment by "a spiral pinion and diagonal rack" works with great accuracy.

Where a small picture is to cover a large screen, at a short distance, the Special Wide Objective No. 6 is recommended.

947.

PROJECTION TABLE

Showing Distance from Object to Screen, Diameter of Picture, in Feet, and Focus of Lens Which Must be Used When Object is Three Inches in Diameter.

Equivalent Focus of Lens	Distance from Object to Screen, in Feet									
	10	20	30	40	50	60	70	80	90	100
15 in.	Diameter of image on screen		6	8	10	12	14	16	18	20
12 "			7½	10	12½	15	17½	20	22½	25
10 "			8	9	12	15	18	21	24	
7½ "		4	8	12	16	20	24			
6 "		5	10	15	20					
5 "		6	12	18	24					

Used through courtesy of Bausch & Lomb Optical Co., Rochester, N. Y.

CHAPTER XLIV.

How the Studies Illustrating This Volume Were Made.

Study No. 1. By Will H. Walker, Portland, Oreg. Subject, "Nydia." This picture was made on a very bright day in the month of June. The picture was taken at 7 P. M. Lens used, Zeiss No. 7-A; focal length, $8\frac{1}{2}$ inches; stop used, f. 8; plate used Seed's Non-Halation; developer, Pyro; printing process, Angelo Sepia Platinum, mounted on salmon-color mount. Frontispiece.

Study No. 2. By Louis Fleckenstein, Los Angeles, Calif. Subject, "Bonne Nuit." A duplicate of this print was hung at the Royal Photographic Society Exhibition in London. The subject was Miss Grace Golden, of Minneapolis, Minn., a well-known and very talented violinist. The picture was made in a room 12 x 12 feet; style of light, ordinary window facing north; size of light, the upper half of the window; lens used, Scientific Lens Company f. 4 Portrait; focal length, $10\frac{1}{2}$ inches; stop used, f. 5; exposure given, 2 seconds; plate used, Lumière Special Portrait; developer, Rodinal; printing process, Autotype Sepia Carbon Tissue, printed from reverse side of negative. The picture was mounted on a deep salmon-color mount with a narrow margin of carbon-brown. (See Page 21.)

Study No. 3. By Mrs. Nancy Ford Cones, Covington, Ky. Subject, "Do You Want a Bite?" The exposure was made at 3 P. M. on a fair day. The lens used was a Bausch & Lomb Rapid Rectilinear; stop used, U. S. 32; exposure given, 1 second; plate used, Cramer Banner developed in Metol-Hydroquinon; printing process, Aristoplatino sepia tone mounted on sepia mount. (See page 22.)

Study No. 4. By Charles E. Fairman, Washington,

D. C. Subject, "Portrait of Child." This is a direct print made from an enlarged negative. In the original negative the head of the child is $\frac{3}{8}$ of an inch wide. The original portrait was made out of doors and against the light. The printing process was Willis & Clements Sepia Platinum, framed in a sepia oak frame. (See Page 41.)

Study No. 5. By Eva Godley Rolfe, Washington, D. C. Lady at Window. The exposure was made in the morning with a Rapid Rectigraph lens. The lens was used wide open, without stop; plate used, Seed regular 26-X, developed in Pyro. There was no altering or manipulation of the plate after development; printing process, Willis & Clements Sepia mounted on a triple combination mount, first layer sepia-brown, followed with a deep salmon-color and finally a dark brown. (See Page 53.)

Study No. 6. By Mary G. Huntsman, Providence, R. I. Title, "Mother and Child." The exposure was made at noon of a clear day; lens used, Bausch & Lomb Unar; focal length, 10 inches; stop used, U. S. 4; exposure given, 2 seconds; plate used, Seed 27, developed in Edinol; printing process, Angelo Sepia Platinum. The light used was a side light with small over-head light. (See Page 83.)

Study No. 7. By Helen W. Cook, Providence, R. I. "Punishment." Made with a Smith Semi-Achromatic lens; stop used, wide open; print was placed on a cream mount. (See Page 84.)

Study No. 8. By J. H. Field, Berlin, Wis. This picture was taken in a doorway between two rooms and the sunlight from the window of one room furnished the strong high-light. Diffused light was obtained from the windows in the opposite room, which were in shadow. No curtains were used on the windows. The lens used was an 8 x 10 portrait lens; plate used, Seed 26-X; developer used, straight Pyro and Soda with no after manipulation. Mounted on combination mount—first section egg-color, followed with a white. (See Page 108.)

Study No. 9. By Miss Mathilde Weil, Philadelphia, Pa. This picture was made in the home with rectilinear lens, 12 inch focus, largest opening; plate used, $6\frac{1}{2} \times 8\frac{1}{2}$,

developed with Metol-Hydroquinon; print was made on sepia platinum paper mounted on deckle-edged Japanese tissue over Nile-green, followed with a sepia-brown and the final mount is a strawboard over which is stretched a deckle-edged Japanese tissue. (See Page 134.)

Study No. 10. By Mrs. M. S. Gaines, Mobile, Ala. Title, "The Cup That Cheers." This picture was taken in the home at 9 A. M.; lens used was a *Plastigmat*; used wide open; exposure given, 1 second; plate used, *Hammer*, developed in *Pyro*; printing process, *gum-bichromate*. This picture was taken in a white-washed room flooded with sunshine—subject just out of sunlight with back to light. (See Page 158.)

Study No. 11. By Mrs. Nancy Ford Cones, Covington, Ky. Subject, "Fairy Tales." The exposure was made at 2 P. M. of a fair day in the home; lens used, *Manhattan Rapid Rectilinear*; stop used, U. S. 4; exposure given, 6 seconds; plate used was a *Cramer Banner*, developed in *Metol-Hydroquinon* with no after manipulation; printing process, *Aristo-platino*, sepia tone mounted on sepia mount. (See Page 170.)

Study No. 12. At-home Portrait, a study by the Perry Studio, Allegheny, Pa. This picture was made by an ordinary home window; lens used was a 3-D *Dallmeyer*; developed in *Pyro-soda* developer with no local reducing or intensifying; plate used, *Seed 27*. (See Page 190.)

Study No. 13. By Frances B. Johnston, Washington, D. C. Subject, "Making Paper Dolls." The picture was made in the afternoon about 2 P. M.; lens used, *Zeiss 7-A*; focal length, 14 inches; stop used, f. 8; plate, *Seed*, developed with *Pyro* with no after manipulation; printing process, *Sepia Platinum*, mounted on combination mount—first sepia-brown, second salmon-color. (See Page 196.)

Study No. 14. By John S. Neary, Trenton, N. J. Title, "Two Against One." The exposure was made at 2:30 P. M. with a *Premo* camera, 5 x 7, fitted with a *Goerz* lens. The picture was taken in the home; size of room, 12 x 15 ft. The light used was from one window in the room; no screens; ordinary plate was used and developed with *Pyro*. (See Page 202.)

Study No. 15. By W. H. Partridge, Boston, Mass. Subject, "Good Morning." (Child and dog). This picture was made in the home by flashlight with a Nichols' flash machine. The diffusion was obtained by a cotton umbrella attached to the machine; lens used was a Ross; focal length, 10 inches; stop, about $\frac{1}{3}$; plate used, Hammer regular, developed with Pyro; printing process, Willis & Clements Platinum paper. (See Page 232.)

GENERAL INDEX.

VOLUME VI.

Aberration, Chromatic	582
Aberration, Correction of Chromatic.....	583
Aberration, Correction of Spherical.....	585
Aberration, Spherical	584
Accessories—Baby and Child Photography.....	391-393
Accessories, Selection of.....	182
Accuracy of Shutters.....	702
Achromatic Lens, An.....	583
Actinic Rays of Light.....	581
Actual Illuminating Space—Interior Photography.....	67
Adjustment of Arc for Projecting and Enlarging.....	939
Adjustment of Electric Release and Circuit Breaker.....	567-569
Advantages of a Studio.....	171
Advantages of Home Surroundings.....	172
Advantages of the Focal Plane Shutter.....	559
Aim in Portraiture, Definite.....	152
Air Bubbles in Anastigmat Lenses.....	786-790
Amount of Powder to Use—Flashlight Photography.....	513-516
Anastigmat is Desirable, Why an.....	649-655
Anastigmat Lenses	588-591
Anastigmat Lenses, Air Bubbles in.....	786-790
Anastigmat Lenses, Bausch & Lomb.....	720-763
Anastigmat Lenses, Cooke.....	829-859
Anastigmat Lenses, Goerz.....	764-820
Anastigmat Lenses not Always Desirable.....	650
Anastigmat Lenses, Superiority of.....	648
Angle Covered by any Size Plate, To Ascertain the.....	820
Angle of Field of the Lens.....	596
Angle of Incidence.....	577, 578

Angle of Refraction.....	577-579
Angle of View of Lens.....	597, 885
Angle of View of Lens, Diagram Showing.....	Page 346
Aperture of Lens, Relative.....	867
Aperture on Depth of Focus of Lens, Influence of.....	619
Aplanatic Lenses	585
Apochromatic Tessar Lens, Bausch & Lomb-Zeiss.....	733
Application of Bausch & Lomb-Zeiss Tessar Lens to Hand Camera	728
Applying Backing Mixture.....	28
Architectural Photography, Stop for.....	687
Arms and Hands—Posing Details.....	233
Arrangement of Family Groups.....	438-443
Arrangement of Groups, Pyramidal.....	435-437
Arrangement of Objects—Interior Photography.....	31
Arranging the Camera—Baby and Child Photography.....	385
Arranging the Drapery—Children's Portraits.....	401-403
Ascertaining the Exposure—Interior Photography.....	50
Astigmatism.....	588-591, 881-884
Astigmatism, Test for.....	589
At-home Portrait, Illustration of.....	Page 65
“At-home Portrait,” Study No. 9, by Mathilde Weil.....	Page 134
“At-home Portrait,” Study No. 12, by Perry.....	Page 190
At-home Portraits, Value of.....	127-129
At-home Portraiture—Avoid Reflections.....	190
At-home Portraiture—Backgrounds	179-187
At-home Portraiture—Broad Profile Lightings.....	336-347
At-home Portraiture—Character Destroyed by Retouching....	151
At-home Portraiture—Controlling the Light.....	157-169
At-home Portraiture—Definite Aim in Portraiture.....	152
At-home Portraiture—Description of Illustrations.....	131-136
At-home Portraiture—Developing	225, 226
At-home Portraiture—Easily Mastered.....	148
At-home Portraiture—Effect of Color.....	150
At-home Portraiture—Examples of.....	Page 69
At-home Portraiture—Exposure	220-224
At-home Portraiture—General Information.....	170-178
At-home Portraiture—Illustration of Plain Portrait Lighting Page 107	
At-home Portraiture—Illustration of Rembrandt Lighting Page 133	
At-home Portraiture—Important General Notes.....	255-270
At-home Portraiture—Introduction	147-156
At-home Portraiture—Lens	255, 256
At-home Portraiture—Light Controlling Screen.....	193

At-home Portraiture—Likeness of a Person.....	154
At-home Portraiture—Making General Preparations.....	188-203
At-home Portraiture—Modifications in Lighting.....	149
At-home Portraiture—Money-making Opportunities.....	147
At-home Portraiture—Obtaining Ideas for Posing.....	156
At-home Portraiture Out-of-doors, Illustration of.....	Page 189
At-home Portraiture—Plain Portrait Lighting.....	204-231
At-home Portraiture—Posing Details.....	232-254
At-home Portraiture—Practice Work.....	138-141
At-home Portraiture—Preparing the Window.....	192
At-home Portraiture—Principal Consideration.....	130
At-home Portraiture—Profile Lightings.....	336-371
At-home Portraiture—Reflecting Screen.....	199
At-home Portraiture—Rembrandt Lighting.....	286-335
At-home Portraiture—Rembrandt Lighting—Detailed In- struction	302-325
At-home Portraiture—Selecting a Window.....	188
At-home Portraiture—Setting Must be Harmonious.....	153
At-home Portraiture—Study the Subject.....	155
At-home Portraiture—The Subject	200-202
At-home Portraiture—Two Light Controlling Factors.....	197
At-home Portraiture—Unobstructed Light.....	189
At-home Portraiture—Window Portraits—Illustrations of.....	Page 70
At-home Portraiture—Windows Facing South, East or West can be Made Use of, How.....	191
At-home Portraiture With Home Surroundings.....	124-146
At-home Portraiture With Home Surroundings—Control of Light	126
At-home Portraiture With Home Surroundings—Difficulties.....	142-146
Contrasty Results	146
Flat, The Resulting Picture.....	145
General Appearance Flat on the Ground-glass.....	144
Home Surroundings, Obtaining Real Effect of.....	143
Illuminating the Subject.....	142
Obtaining Real Effect of Home Surroundings.....	143
Resulting Picture Flat, The.....	145
Results Contrasty	146
Subject, Illuminating the.....	142
At-home Portraiture With Home Surroundings, Illustra- tions of	Page 66
At-home Portraiture With Home Surroundings—Light.....	125
Atmosphere in Portraiture.....	206
Attention to Details—Plain Portrait Lighting.....	211
Avoiding Halation, Illustrations of.....	Page 54
Axis of a Lens.....	586

Axis of a Lens, Principal.....	587
Baby and Child Photography.....	372-398
Baby and Child Photography—Accessories.....	391-393
Baby and Child Photography—Arranging the Camera.....	385
Baby and Child Photography—Brief General Instruction....	376-381
Baby and Child Photography—Detailed Instruction.....	382-398
Baby and Child Photography—Development.....	381
Baby and Child Photography—Dress.....	394, 395
Baby and Child Photography—Exposure.....	380
Baby and Child Photography—Introduction.....	372-375
Baby and Child Photography—Lighting.....	378, 386
Baby and Child Photography—Light, The.....	389, 390
Baby and Child Photography—Obtaining Expressions.....	396, 397
Baby and Child Photography—Plates to Use.....	379
Baby and Child Photography—Principal Requirements....	376, 377
Baby and Child Photography—Spacing	387
Backed Plates	26
Back Focus of the Lens.....	610
Back Focus, Illustration of.....	Page 276
Background Be Simple, Let the.....	181
Background Carrier, Illustration of Ingento.....	Page 88
Background Frame, Illustration of Construction of.....	Page 93
Background, Illuminating the—Rembrandt Profile Lighting....	359
Background, Painted	185
Background, Placing the—Plain Portrait Lighting.....	217
Background, Plain	184
Background—Rembrandt Lighting	299, 300, 313
Background, Stretching the	186, 187
Background, Substitute for Painted.....	198
Background, Temporary	174
Background, The	173
Background, Value of Plain.....	183
Backgrounds—At-home Portraiture	179-187
Backgrounds—Groups	450
Backing, Black Paper	29
Backing Mixture	27
Backing Mixture, Applying	28
Bausch & Lomb Extra Rapid Universal Lens.....	762, 763
Bausch & Lomb Lenses, Illustration of.....	Pages 321, 322
Bausch & Lomb Lenses, The.....	720-763
Bausch & Lomb Plastigmat Lens	756-761
Bausch & Lomb Portrait Lenses	908-910
Bausch & Lomb Projection Lens, Illustration of.....	Page 391
Bausch & Lomb Rapid Universal Lens.....	763
Bausch & Lomb Telephoto Lens, Illustration of.....	Page 391

Bausch & Lomb Volute Shutter.....	693
Bausch & Lomb Volute Shutter, Illustration of.....	Page 309
Bausch & Lomb-Zeiss Portrait Lenses, The Diffusing System for	909, 910
Bausch & Lomb-Zeiss Portrait Unar Lens.....	908
Bausch & Lomb-Zeiss Protar Lens.....	739-755
Bausch & Lomb-Zeiss Protar Lens, Series IV.....	741
Bausch & Lomb-Zeiss Protar Lens, Series V.....	742, 743
Bausch & Lomb-Zeiss Protar Lens, Series VII A.....	744-755
Bausch & Lomb-Zeiss Tessar Lens.....	722-738
Bausch & Lomb-Zeiss Tessar Lens, Series I-C.....	735-738
Beginner's Notes on Instantaneous Shutters.....	712-719
Behind-the-Lens Shutter	690
Between-the-Lens Shutter	690-692
Blacking for Wood or Leather.....	849
Black Paper Backing.....	29
Body and Face, Relative Position of.....	263
'Bonne Nuit,' Study No. 2, by Fleckenstein	Page 21
Broad Lighting, Plain or.....	167
Broad Profile Lighting—At-home Portraiture.....	336-347
Broad Profile Lighting—Eyes.....	343
Broad Profile Lighting—Introduction.....	336
Broad Profile Lighting—Lighting.....	347
Broad Profile Lighting—Lips.....	344
Broad Profile Lighting, Placing the Subject for.....	339-341
Broad Profile Lighting—Points to be Considered.....	337
Broad Profile Lighting—Pose.....	342
Broad Profile Lighting—Position of the Body.....	345, 346
Bubbles in Anastigmat Lenses.....	786-790
Camera and Lens for Interior Photography.....	16-19
Camera, Arranging the—Baby and Child Photography.....	385
Camera, Position of the—Plain Portrait Lighting.....	218
Camera, Proper Height of the—Plain Portrait Lighting.....	219
Camera, Reflex	552-560
Camera, The Goerz-Anschutz Folding.....	821-825
Camera, The Goerz-Anschutz Stereoscopic.....	828
Care of Lens.....	918-921
Catch-lights in the Eyes.....	246, 262
Cause of Halation.....	22
Celluloid, Use of.....	177
Celor Lens, Goerz.....	803-808
Center of the Lens, Optical.....	606
Character Destroyed by Retouching—At-home Portraiture....	151
Character, Reproducing	166
Characteristics of Dagor Lenses.....	813-818

Cheese-cloth in Coffee, Dyeing.....	194
Chemical Rays of Light.....	581
Child Drapery Portrait, Illustration of.....	Page 181
Child Portrait Made With Nichols' Flash-Lamp, Illustration of	Page 231
Child, Posing the.....	388
Children, Entertaining	398
Children, Photographing, Outdoors.....	416-421
Children's Portraits—Arranging the Drapery.....	401-403
Children's Portraits in Drapery.....	399-415
Children's Portraits—Lighting	407
Children's Portraits—Posing the Hands.....	404-406
Children's Portraits—Statuettes	408-414
Chin, Height of the—Posing Details.....	236
Choice of Lens.....	886-888
Chromatic Aberration	582
Chromatic Aberration, Correction of.....	583
Chromatic Aberration, Illustration of.....	Page 261
Circuit Breaker, Adjustment of Electric Release and.....	567-569
Class of Goods to Use for Draping.....	400
Coffee, Dyeing Cheese-cloth in.....	194
Collinear Lens Cells.....	893
Collinear Lenses, Voigtlander's.....	889, 890
Color, Effect of—At-home Portraiture.....	150
Combination Daylight and Flashlight Exposure with Reflex Camera	561
Commercial Work, Lens for.....	782, 783
Communication from Schott & Genossen.....	787-790
Comparative Exposures	679
Comparative Sizes of Stops or Diaphragms.....	674
Compounds, Flashlight	478
Concave Lenses	586
Concave Meniscus Lenses.....	586
Concentrate Interest—Interior Photography.....	32
Condenser for Projecting and Enlarging—Triple System....	940, 941
Condensing Lenses, Foci of.....	942
Condensing Lenses, Sectional View of.....	Page 396
Condensing Lenses, The Foci of Single.....	941
Conjugate Focus Beyond the Principal Focus in Inches, Distance of the (Table).....	800
Conjugate Foci of the Lens.....	611
Control of Light—At-home Portraiture With Home Sur- roundings	126
Controlling Factors, Two Light—At-home Portraiture.....	197

Controlling Halation by Special Development—Interior Photography	96-112
Controlling Light—A Necessity.....	164
Controlling Light, First Steps Toward.....	159
Controlling Screen, Diffusing Curtains on.....	195
Controlling Screen for At-home Portraiture, Light.....	193
Controlling the Light.....	293
Controlling the Light—At-home Portraiture.....	157-169
Controlling the Light—Plain Portrait Lighting.....	207, 208
Convex Lenses	586
Cooke Anastigmat Lenses.....	829-859
Cooke Extension Lenses.....	832
Cooke Lens, Series II.....	833-835
Cooke Lens, Series III.....	836
Cooke Lens, Series IV.....	837-839
Cooke Lens, Series V.....	840, 841
Cooke Lenses, Illustrations of.....	Page 352
Cooke Process Lenses.....	842, 843
Correction of Chromatic Aberration.....	583
Correction of Chromatic Aberration, Illustration of.....	Page 262
Correction of Spherical Aberration.....	585
Covering Power of a Lens.....	594-597, 600
Covering Power of a Lens, Illustration of.....	Page 270
Covering Power of a Lens, What is.....	660, 661
Critical Definition, Illustration of.....	Page 271
Critical Definition of the Lens.....	602
Curtains on Controlling Screen, Diffusing.....	195
Curvature of Field of the Lens.....	593, 594, 601
Curvature of Field With Rectilinear Lenses.....	657, 658
Curvature of Lens, Illustration of.....	Page 270
Dagor as a Wide-Angle Lens, The Goerz.....	819
Dagor Lens, Characteristics of.....	813-818
Dagor Lens, Goerz.....	809-819
Dallmeyer Patent Portrait Lenses.....	899-901
Dallmeyer Telephoto Lens, Illustration of.....	Page 389
Dark Walls and Furnishings—Interior Photography.....	43
Daylight, Firelight Effects by.....	422-432
Definite Aim in Portraiture—At-home Portraiture.....	152
Defining Power and Definition of the Lens.....	599
Definition of Bausch & Lomb-Zeiss Tessar Lens.....	724
Definitino of Rembrandt Lighting.....	289, 290
Definition of the Lens.....	599
Definition of the Lens, Critical.....	602
Demonstration, Telephoto	Page 391
Depth of Definition of the Lens.....	618

Depth of Focus, Illustration of Influence of Aperture on..	Page 282
Depth of Focus of Lens.....	618, 872-880, 916, 917
Depth of Focus of Lens, Influence of Aperture on.....	619
Depth of Focus of Lens, Influence of Focal Length on.....	620-622
Detailed Instruction—Baby and Child Photography.....	382-398
Detailed Instruction—Rembrandt Lighting.....	302-325
Detail Should Prevail—Interior Photography.....	46
Determining Focal Length of Lens Suitable for Operating Rooms of Stated Length	783-785
Developing At-home Portraiture	225, 226
Developing—Photographing Children Outdoors.....	421
Developing—Plain Portrait Lighting.....	225, 226, 270
Developing—Profile Lighting	364
Developing—Rembrandt Lighting	319
Developing Specially Prepared Plates—Interior Photography.	75-77
Development—Baby and Child Photography	381
Development—Firelight Effects by Daylight.....	427
Development—Flashlight Photography.....	485, 521
Development—Interior Photography	72-77
Diagram of Electric Connection for Reflex Camera.....	Page 252
Diaphragm or Stop Systems Compared.....	676
Diaphragms	670-688, 866
Diaphragms, Comparative Sizes of.....	674
Difference in Definition Between Rectilinear and Anastigmat Lenses.....	652, 653
Difficulties—At-home Portraiture with Home Surroundings (See At-home Portraiture with Home Surroundings—Difficulties)	142-146
Difficulties—Flashlight Photography (See Flashlight Photography—Difficulties)	541-551
Difficulties—Groups (See Groups—Difficulties)	457-471
Difficulties—Interior Photography (See Interior Photography—Difficulties)	113-123
Difficulties—Plain Portrait Lighting (See Plain Portrait Lighting—Difficulties)	271-285
Difficulties—Rembrandt Lighting (See Rembrandt Lighting—Difficulties)	326-335
Diffused Light—Interior Photography	42
Diffusing a Lens, Manner of.....	902
Diffusing Curtains on Controlling Screen	195
Diffusing Experiment—Rembrandt Lighting	310-312
Diffusing High-lights—Rembrandt Lighting.....	302-304
Diffusing Screen—Flashlight Portraiture	494-496
Diffusing Screen, Use of	207
Diffusing System for Bausch & Lomb Portrait Lens, The..	909, 910

Diffusing the Light	165
Diffusing the Light—Groups.....	451
Dining-room, Illustration of a Simply Arranged.....	Page 45
Dining-rooms, Photographing	79-85
Direction of Light—Interior Photography.....	104
Dispersion, Illustration of.....	Pages 259, 260
Dispersion of Light.....	580
Distance and Size of Image, Ratio of.....	612, 613
Distance from Camera to Subject—Interior Photography.....	33
Distance of the Conjugate Focus Beyond the Principal Focus in Inches (Table)	800
Distances Rendered Sharp at the Same Time, Subjects Sit- uated at Various	683, 684
Distorted Perspective, Illustration of.....	Pages 380, 381
Distorted Perspectives in Portraiture.....	913-915
Distortion When Using Focal Plane Shutter.....	704
Diverging Lenses	586
Dodging During Exposure—Interior Photography.....	39
“Do You Want a Bite?” Study No. 3, by Nancy Ford Cones. Page	22
Drapery, Arranging the—Children’s Portraits.....	401-403
Drapery, Children’s Portraits in	399-415
Drapery Portrait, Illustration of Child.....	Page 181
Drapery, Wrinkles in.....	234, 235
Draping, Class of Goods to Use for.....	400
Dress—Baby and Child Photography.....	394, 395
Drop Shutter, The	690, 691
Dudley Hoyt, Photo by.....	Page 385
Dyeing Cheese-cloth in Coffee.....	194
Dynar Lens Cells, Voigtlander’s.....	893
Dynar Lens, Voigtlander’s	891, 892
Easily Mastered, At-home Portraiture.....	148
Eastman Flashlamp, Illustration of.....	Page 216
Efficiency, Shutter	700, 701
Effect of All Top Light.....	162
Effect of All Side Light.....	161
Effect of Color—At-home Portraiture.....	150
Electric Connection for Reflex Camera, Diagram of.....	Page 252
Electric Connection, Reflex Camera with, Illustration of..	Page 250
Electric Current for Flashpan.....	565
Electric Flashpan, Construction of.....	563
Electric Release and Circuit Breaker, Adjustment of.....	567-569
Electric Release for Making Flashlight Exposure.....	566
Emission, Node of	596, 606
Enlarging, Adjustment of Arc for.....	939
Enlarging and Projecting Lenses.....	937-939

Enlarging Lens, Sectional View of.....	Page 398
Enlarging, Lenses for.....	943-946
Enlarging, Triple System Condenser for.....	940, 941
Entertaining Children	398
Equality of Illumination of Lenses.....	662
Equivalent Focus, Illustration of.....	Page 275
Equivalent Focus of the Lens.....	608, 609
Essential Feature of the Reflex Camera.....	553
Euryscope Lens, Voigtlander's.....	896
Euryscope Lens, Voigtlander's Portrait.....	903
Even Illumination—Interior Photography.....	106, 107
Evenness of Illumination of the Lens.....	604
Examples of Work with Focal Plane Shutter.....	Page 249
Experiment, Diffusing—Rembrandt Lighting.....	310-312
Explanation of Front View of Nichol's Flashlamp.....	491
Explanation of Rear View of Nichol's Flashlamp.....	492, 493
Exposure—At-home Portraiture.	220-224
Exposure, Ascertaining the—Interior Photography.....	50
Exposure—Baby and Child Photography.....	380
Exposure Depends on Varying Conditions—Interior Pho- tography	49
Exposure—Firelight Effects by Daylight.....	426
Exposure—Groups	449
Exposure in Telephotography.....	935, 936
Exposure—Interiors Having Stained Glass Windows—In- terior Photography	48
Exposure—Interior Photography	47, 87, 102, 103
Exposure—Plain Portrait Lighting.....	220-224, 269
Exposure—Profile Lightings	363
Exposure, Reflex Camera Ready for Instant.....	554
Exposure—Rembrandt Lighting	301, 318
Exposure Table for Interior Photography.....	51-58
Exposure, The—Flashlight Photography.....	517
Exposure with Reflex Camera and Flashlamp, Making.....	570
Exposure with Reflex Camera, Combination Daylight and Flashlight	561
Exposures, Comparative	679
Exposures for Varying Proportions of Image to the Orig- inal, Relative	791-798
Exposures, How to Find the Relative.....	681
Exposures, Making—Interior Photography.....	60
Expression, Obtaining—Baby and Child Photography.....	396, 397
Expression, Securing—Photographing Children Outdoors.....	420
Extra Rapid Universal Lens, Bausch & Lomb.....	762, 763
Eye Rest	247-250

Eyes—Broad Profile Lighting	343
Eyes, Catch-lights in the.....	246, 262
Eyes—Posing Details	244
Face and Body, Relative Position of.....	263
Face, Proper View of the—Rembrandt Profile Lighting.....	351
Factors, Two Light Controlling—At-home Portraiture.....	197
“Fairy Tales,” Study No. 11, by Nancy Ford Cones.....	Page 170
Family Group, Illustration of.....	Page 201
Family Groups, Arrangement of	438-443
<i>f</i> Diaphragm Value, to Secure the.....	677, 678
Field of the Lens, Angle of	596
Field of the Lens, Curvature of the.....	593, 594
Field of the Lens, Illustration of the.....	Page 267
Field of the Lens, Relative Position of Plate and.....	603
Field of the Lens, The	592
Field with Rectilinear Lenses, Curvature of.....	657, 658
Figure, Pose of.....	264
Find the U. S. Number When Number Is Given for the <i>f</i> System	680
Firelight Effects by Daylight	422-432
Firelight Effects by Daylight—Development.....	427
Firelight Effects by Daylight—Exposure	426
Firelight Effects by Daylight, Illustration of.....	Page 195
Firelight Effects by Daylight—Introduction.....	422-425
Firelight Effects by Daylight—Practice Work.....	429-432
Firelight Effects by Daylight—Printing.....	428
First Steps Toward Controlling Light.....	159
Flashlamp, Illustration of Child’s Portrait Made with Nichol’s	Page 231
Flashlamp, Illustration of Eastman.....	Page 216
Flashlamp, Illustration of Luxo, Style D.....	Page 217
Flashlamp, Illustration of Nichols’ Junior.....	Page 222
Flashlamp, Illustration of Nichols’ Professional.....	Page 222
Flashlamp, Illustration of Sectional Rear View of Nichols’.....	Page 224
Flashlamp, Illustration of Sectional Front View of Nich- ols’	Page 223
Flashlamp, Position of the.....	507
Flashlamp, Reflex Camera in Conjunction with—by M. J. Shields	552-571
Flashlight Compounds	478
Flashlight Compounds, Methods of Igniting	479
Flashlight Equipment in Conjunction with Reflex Camera.....	562
Flashlight Exposure, Electric Release for Making.....	566
Flashlight Exposure with Reflex Camera, Combination Day- light and	561

Flashlight, Groups and Interiors by.....	522-540
Flashlight, Groups by	522-525
Flashlight—Interior Photography, General.....	527-529
Flashlight Photography—Amount of Powder to Use.....	513-516
Flashlight Photography—Developing.....	485, 521
Flashlight Photography— Difficulties	541-551
Detail in Shadows, Lack of.....	542
Explodes, Flashlamp	547
Eyes of the Sitter Closed.....	543
Flash-compound Refuses to Ignite	546
Flat and Lifeless, Portrait.....	545
Focus	549
Foggy Appearance of Portrait, Misty.....	544
Hard Lighting	541
Ignite, Flash-compound Refuses to.....	546
Lack of Detail in Shadows.....	542
Lamp Chokes Up, Magnesium.....	551
Lighting Hard	541
Magnesium Lamp Chokes Up.....	551
Misty, Foggy Appearance of Portrait.....	544
No Image on the Plate	548
Proper Amount of Powder to Use.....	550
Portrait Flat and Lifeless.....	545
Powder to Use, Proper Amount of.....	550
Shadows, Lack of Detail in.....	542
Flashlight Photography—Exposure	517
Flashlight Photography—Focusing	511
Flashlight Photography—General	472-485
Flashlight Photography, General—Practice Work.....	484
Flashlight Photography—Preparing the Fuse	481
Flashlight Photography—Shielding the Lens.....	483
Flashlight Photography—Shutter to Use	518, 519
Flashlight Photography—Smoke	520
Flashlight Photography—Stops	512
Flashlight, Placing the	482
Flashlight Portraiture	486-521
Flashlight Portraiture—Diffusing Screen	494-496
Flashlight Portraiture—Floor Plan for Plain Lighting....	Page 228
Flashlight Portraiture—Floor Plan for Rembrandt Lighting	
	Page 229
Flashlight Portraiture—Groups	510
Flashlight Portraiture—Introduction	486-490
Flashlight Portraiture—Lens Hood	501-506
Flashlight Portraiture—Plain Portrait Lighting.....	508
Flashlight Portraiture—Reflectors	497-499

Flashlight Portraiture—Rembrandt Lighting	509
Flashlight Portraiture—Shading the Lens.....	500
Flashlight Powders	473
Flash Machines	537-539
Flashpan, Construction of Electric	563
Flashpan, Electric Current for.....	565
Flashpan, Fuse for Electric	564
Flash-sheets, Magnesium	474
Flat Effects Outdoors	158
Flesh-effects Lacking	160
Floor Plan—Flashlight Portraiture—Plain Lighting.....	Page 228
Floor Plan—Flashlight Portraiture—Rembrandt Lighting.....	Page 229
Floor Plan—Plain Portrait Lighting.....	Page 103
Floor Plan—Rembrandt Lighting	Page 136
Floor Plan—Rembrandt Profile Lighting.....	Page 155
Focal Distance of the Lens Due to Different Distances of the Object, Increase of the.....	799-802
Focal Length of Lens	606, 607, 665, 862-864
Focal Length of Lens Suitable for Operating Rooms of Stated Length, Determining	783-785
Focal Length of Lens, To Measure.....	614-617
Focal Length on Depth of Focus of the Lens, Influence of..	620-622
Focal Plane Shutter, Distortion When Using.....	704
Focal Plane Shutter, Examples of Work with.....	Page 249
Focal Plane Shutter, Illustration of.....	Page 316a
Focal Plane Shutter, Principle of.....	718
Focal Plane Shutter, Safety of.....	703
Focal Plane Shutter, The.....	690, 895-704, 718, 826, 827
Focal Value of a Stop, To Find the.....	675
Foci of Condensing Lenses.....	942
Foci of Single Condensing Lenses.....	941
Foci of the Lens, Conjugate	611
Focus	605-607
Focus (Definition) of Lens, Depth of.....	618, 872-880
Focus, How to	851-859
Focus of Lens, Back	610
Focus of Lens, Equivalent.....	608, 609
Focus of Lens, Influence of Aperture on Depth of.....	610
Focus of Lens, Influence of Focal Length on Depth of.....	620-622
Focus of Lens, Principal.....	606
Focusing	30
Focusing—Flashlight Photography	511
Focusing Hood—Reflex Camera	557, 558
Focusing—Interior Photography	86
Folding Camera, The Goerz-Anschutz.....	821-825

Form of Lenses.....	586, 587
Forms of Lenses, Illustration of.....	Page 264
<i>f</i> System, to Find the U. S. Number When Number Is Given for the	680
Function of the Lens	573-576
Fuse for Electric Flashpan, The.....	564
Fuse for Flashlight Photography, Preparing the.....	481
General Flashlight Interior Photography	527-529
General Flashlight Photography	472-485
General Information—At-home Portraiture	170-178
General Interior View, Illustration of a.....	Page 46
General Work, Bausch & Lomb-Zeiss Tessar for.....	731
Glass, Refractive Power of.....	579
Goerz Anastigmat Lenses	764-825
Goerz-Anschutz Folding Camera, Illustration of.....	Page 347
Goerz-Anschutz Folding Camera, The.....	821-825
Goerz-Anschutz Stereoscopic Camera, Illustration of.....	Page 348
Goerz-Anschutz Stereoscopic Camera, The.....	828
Goerz Celor Lens.....	803-808
Goerz Dagor Lens.....	809-819
Goerz Dagor Lens as a Wide-angle Lens.....	819
Goerz Lenses, Illustration of.....	Page 332
Goerz Telephoto Lens, Illustration of.....	Page 391
Goerz XL Sector Shutter	693
Goerz XL Sector Shutter, Illustration of	Page 309
Good Drawing—Groups	444
"Good Morning," Study No. 15, by Partridge.....	Page 232
Group by Flashlight	522-525
Group, Illustration of Family.....	Page 201
Group—Mother and Children—Illustration of.....	Page 201
Group—Pyramidal Arrangement—Illustration of.....	Page 169
Groups	433-471
Groups and Interiors by Flashlight.....	522-540
Groups and Interiors by Flashlight—Practice Work.....	540
Groups—Arrangement of Family.....	438-443
Groups—Backgrounds	450
Groups—Difficulties	457-471
Adults, Arranging Groups of.....	459
Arrangement of Groups.....	457
Arranging Full Length Groups.....	463
Arranging Groups of Adults	459
Arranging Groups of Children	458
Arranging Groups of Two	460
Arranging Large Groups	461
Arranging Three-quarter Length and Bust Groups....	465

Children, Arranging Groups of.....	458
Congeniality, Preserving	462
Contrasty Results	470
Correct Angle of Light for All Subjects.....	466, 467
Effects, Spotted	471
Even Illumination	468
Hands, The	464
Illumination, Even	468
Groups, Arrangement of	457
Groups, Arranging Large	461
Groups, Arranging Full Length.....	463
Groups, Arranging Three-quarter Length and Bust... 465	
Groups, Correct Angle of Light for All Subjects in	466, 467
Groups of Adults, Arranging	459
Groups of Children, Arranging.....	458
Groups of Two, Arranging	460
Large Groups, Arranging	461
Lighting for Quick Exposures, Proper.....	469
Preserving Congeniality	462
Proper Lighting for Quick Exposures.....	469
Spotted Effects	471
Groups—Diffusing the Light.....	471
Groups—Exposure	449
Groups—Flashlight Portraiture	510
Groups—Good Drawing	444
Groups—Lighting	445-448
Groups—Practice Work	453-456
Groups, Pyramidal Arrangement of	435-437
Groups—Reflecting Screen	452
Hair—Posing Details	251-254
Halation by Special Development, Controlling—Interior Photography	96-112
Halation, Cause of	22
Hand Posing—Children's Portraits.....	404-406
Hand Posing, Illustration of.....	Page 182
Hands and Arms—Posing Details.....	233
Hanging Screen in Window	196
Head, Position of the—Plain Portrait Lighting.....	260, 261
Height of the Camera, Proper—Plain Portrait Lighting.....	219
Height of the Chin—Posing Details.....	236
Heliar Lens, Voigtlander's.....	894, 895, 904-907
Holding Subject's Attention	249, 250
Home Surroundings, Advantages of.....	172
Home Surroundings, At-home Portraiture with.....	124-146

How to Preserve Lenses	844-848
How to Test Lenses	850-859
Igniting Flashlight Compounds, Methods of.....	479
Illuminant for Projection Work.....	938
Illuminating Shadows—Interior Photography.....	105-107
Illuminating the Background—Rembrandt Profile Lighting....	359
Illumination, Even—Interior Photography.....	106, 107
Illumination of Bausch & Lomb-Zeiss Tessar Lens.....	725
Illumination of Lens, Circle of.....	595
Illumination of Lenses, Equality of.....	662
Illumination of Lenses, Evenness of	604
Image, Ratio of Distance and Size of.....	612, 613
Image Sharp? When Is an.....	599
Importance of Omitting the Unnecessary	175
Important General Notes—At-home Portraiture.....	255-270
Improvement in Lenses, The Main Points of.....	767, 777
Improving Profile by Proper Lighting.....	353
Incidence, Angle of	577, 578
Incidental Advantage of the Bausch & Lomb-Zeiss Tessar, An	734
Increase of the Focal Distance of the Lens Due to Different Distances of the Object	799-802
Indoor Photography with Magnesium and Flashlight Pow- ders	472
Infants' Pictures, Illustration of Series of.....	Page 169
Influence of Aperture on Depth of Focus of Lens.....	619
Influence of Depth of Focus, Illustration of.....	Page 282
Influence of Focal Length on Depth of Focus of the Lens....	620-622
Ingento Background Carrier, Illustration of.....	Page 88
Interior Photography	10-123
Interior Photography—Actual Illuminating Space.....	67
Interior Photography—Admitting Windows Into the View... 96,	97
Interior Photography—Arrangement of Objects.....	31
Interior Photography—Ascertaining the Exposure.....	50
Interior Photography, Camera and Lens for.....	16-19
Interior Photography—Concentrate Interest.....	32
Interior Photography—Controlling Halation by Special De- velopment	96-112
Interior Photography—Dark Walls and Furnishings.....	43
Interior Photography—Detail Should Prevail.....	46
Interior Photography—Developing Specially Prepared Plates. 75-77	
Interior Photography—Development	72-77
Interior Photography—Difficulties	113-123
Arranging the Furniture	116
Contrasty, Plate Developing	121

Developing Contrasty, Plate.....	121
Development, Plate Fogging During.....	122
Exposure, Judging Proper	118
Focusing	117
Fogging During Development, Plate.....	122
Furniture, Arranging the	116
Halation, Overcoming	119
Illumination, Securing Even.....	113, 114
Judging Proper Exposure	118
Obtaining a General View of the Room.....	115
Obtaining Detail in the Shadows.....	120
Overcoming Halation	119
Plate Developing Contrasty.....	121
Plate Fogging During Development.....	122
Room, Obtaining a General View of the.....	115
Securing Even Illumination	113, 114
Shadows, Obtaining Detail in the.....	120
Thin Negatives, Full of Detail, but with No Print- ing Quality When Using Non-halation Plates.....	123
Interior Photography—Diffused Light.....	42
Interior Photography—Direction of Light.....	104
Interior Photography—Distance from Camera to Object.....	33
Interior Photography—Dodging During Exposure.....	39
Interior Photography—Even Illumination	106, 107
Interior Photography—Exposure.....	47, 87, 102, 103
Interior Photography—Exposure Depends on Varying Con- ditions	49
Interior Photography—Exposure—Interiors Having Stained Glass Windows	48
Interior Photography, Exposure Table for.....	51-58
Interior Photography—Focusing	86
Interior Photography—General Flashlight	527-529
Interior Photography—Illuminating Shadows	105-107
Interior Photography—Introducing Figures	37
Interior Photography, Judging Strength of Light in.....	62, 63
Interior Photography—Lighting	40
Interior Photography—Lighting Figures	45
Interior Photography—Location of Figures.....	38
Interior Photography—Making Exposures	60
Interior Photography—Plates to Use.....	21
Interior Photography—Practice Work	85-95, 111
Interior Photography—Requirements	71
Interior Photography—Selection of View Point.....	101
Interior Photography—Source of Light—Location.....	44
Interior Photography—Space to Be Illuminated.....	68, 69

Interior Photography—Stops	70, 687
Interior Photography—Sun Shining on Windows.....	99
Interior Photography—Technical Detail	35
Interior Photography—Three Examples of.....	78-84
Interior Photography—Time of Day.....	41
Interior Photography—Tripod	20
Interior Photography—Under-exposure	59
Interior Photography—Use of Alkali	109
Interior Photography—Windows Included in View.....	34
Interior Photography—Windows in View.....	100
Interior Photography—Working in Confined Positions.....	61
Interior Portraiture, Reflex Camera Adapted to.....	560
Interiors and Groups by Flashlight.....	522-540
Interiors, Time of Day to Make.....	98
Interiors of Residences, Photographing.....	10-61
Interior View, Illustration of a General.....	Page 46
Introducing Figures—Interior Photography.....	37
Introduction—At-home Portraiture	147-156
Introduction—Baby and Child Photography.....	372-375
Introduction—Broad Profile Lightings	336
Introduction—Firelight Effects by Daylight.....	422-425
Introduction—Flashlight Portraiture	486-490
Introduction—Photographing Children Outdoors.....	416-418
Introduction—Rembrandt Lighting	286, 287
Iris Diaphragms	671
Jena Glass, Air-bubbles in	786-790
Judging Strength of Light in Interior Photography.....	62-66
Kind of Flash Material	530-533
“Lady and Child in Open Door,” Study No. 8, by Field....	Page 108
“Lady at Window,” Study No. 5, by Eva G. Rolfe.....	Page 53
Lamp, Magnesium	476
Largest Stop, The	688
Lawrence, S.—Photographic Lenses—Their Nature and Use, by	572-648
Leather, Blacking for.....	849
Lens, Achromatic	583
Lens, Angle of Field of the.....	596
Lens, Angle of View of the.....	597, 885
Lens—Astigmatism	881, 884
Lens—At-home Portraiture	255, 256
Lens, Axis of	586
Lens, Back Focus of the.....	610
Lens, Bausch & Lomb-Zeiss Rapid Universal.....	762, 763
Lens, Bausch & Lomb-Zeiss Portrait Unar.....	908
Lens, Bausch & Lomb-Zeiss Tessar	722-738

Lens, Care of	918-921
Lens Cells, Collinear and Dynar.....	893
Lens, Choice of	886-888
Lens, Circle of Illumination of the	595
Lens Compared with Anastigmat, Rectilinear.....	649-665
Lens, Conjugate Foci of the.....	611
Lens, Cooke Series II	833-835
Lens, Cooke Series III	836
Lens, Cooke Series IV	837-839
Lens, Cooke Series V	840, 841
Lens, Covering Power of the.....	594-597, 600
Lens Cover, What Plate Will the.....	664
Lens, Critical Definition of the.....	602
Lens, Curvature of the Field of the.....	593, 594, 601
Lens, Defining Power and Definition of the.....	599
Lens Demonstration, Bausch & Lomb-Zeiss Protar..	Pages 325, 326
Lens, Depth of Focus (Definition) of.....	618, 872, 880, 916, 917
Lens, Diagram Showing Angle of View of.....	Page 346
Lens, Equivalent Focus of the	608, 609
Lens, Evenness of Illumination of the.....	604
Lens, Field of the.....	592
Lens, Focal Length of the.....	606, 607, 665, 862-864
Lens, Focus of	605-607
Lens for Commercial Work	782, 783
Lens for Enlarging	945, 946
Lens for Interior Photography.....	16-19
Lens for Newspaper Photography	736
Lens for Portraiture	781
Lens, Function of the	573-576
Lens, Goerz Celor	803-808
Lens, Goerz Dagor	809-819
Lens, Goerz Dagor as a Wide-angle.....	819
Lens, Telephoto, Illustration of Goerz.....	Page 391
Lens Hood—Flashlight Portraiture	501-506
Lens Hood, Illustration of.....	Page 226
Lens, Influence of Aperture on Depth of Focus.....	619
Lens, Influence of Focal Length on Depth of Focus of the..	620-622
Lens Is Desirable, Why an Anastigmat.....	649-665
Lens, Manner of Diffusing a.....	902
Lens, Optical Center of the.....	606
Lens, Principal Focus of the.....	606
Lens, Projection, Illustration of B. & L.....	Page 391
Lens, Relative Aperture of the.....	867
Lens, Relative Position of Plate and Field of the.....	603
Lens, Sectional View of Condensing	Page 396

Lens, Sectional View of Enlarging.....	Page 398
Lens, Shielding the—Profile Lighting.....	362
Lens, Size of a.....	659
Lens Speed	865-868
Lens, Stopping Down the—At-home Portraiture.....	257, 258
Lens Suitable for Operating Rooms of Stated Length, De-termining Focal Length of	783-785
Lens, Telephoto, Illustration of B. & L.....	Page 391
Lens, The Larger the Stop the Better the.....	682
Lens, To Measure Focal Length of.....	614-617
Lens, Voigtlander's Collinear.....	889, 890
Lens, Voigtlander's Dynar	891, 892
Lens, Voigtlander's Euryscope.....	896
Lens, Voigtlander's Heliar.....	894, 895, 904-907
Lens? What Is Covering Power of a	660, 661
Lens, Why the Margins Are Not Sharp with a Rectilinear. .	654-656
Lens, Wide-angle	598, 663
Lens, Anastigmatic	588-591
Lenses, Aplanatic	585
Lenses, Bausch & Lomb	720-763
Lenses, Bausch & Lomb Anastigmat	720-761
Lenses, Bausch & Lomb Portrait	908-910
Lenses, Characteristics of Goerz Dagor.....	813-818
Lenses, Concave	586
Lenses, Concave Meniscus	586
Lenses, Converging	586
Lenses, Convex	586
Lenses, Cooke Anastigmat	829-859
Lenses, Cooke Extension	832
Lenses, Cooke Process	842, 843
Lenses, Curvature of Field with Rectilinear.....	657, 658
Lenses, Dallmeyer Patent Portrait.....	899-901
Lenses, Diffusing System for Bausch & Lomb Portrait....	909, 910
Lenses, Dispersion	580
Lenses, Diverging	586
Lenses, Equality of Illumination of	662
Lenses, Foci of Condensing.....	942
Lenses, Foci of Single Condensing	941
Lenses, Forms of	586, 587
Lenses, Goerz Anastigmat	764-825
Lenses, How to Preserve	844-848
Lenses, How to Test.....	850
Lenses, Illustration of Bausch & Lomb.....	Pages 321, 322
Lenses, Illustration of Cooke.....	Page 352
Lenses, Illustration of Goerz.....	Page 332

Lenses, Illustrations of Portrait.....	Pages 374-379
Lenses, Illustrations of Voigtlander's.....	Pages 367, 371, 374, 375
Lenses, Main Points of Improvement in.....	768-777
Lenses, Meniscus	586
Lenses, Negative	586
Lenses Not Always Desirable, Anastigmat	650
Lenses, Photographic—Their Nature and Use—by S. Lawrence	572-648
Lenses, Plano Concave	586
Lenses, Plano Convex	586
Lenses, Portrait	897-921
Lenses, Positive	586
Lenses, Projecting and Enlarging	937-947
Lenses—Refraction	577-579
Lenses, Selection of.....	778-782
Lenses, Speed of—How to Determine.....	623-647
Lenses, Speed of Portrait	911, 912
Lenses, Superiority of Anastigmat.....	648
Lenses, Symmetrical	869, 870
Lenses, Telephoto, Illustrations of Voigtlander's.....	Page 389
Lenses, Telephotographic	922-936
Lenses, Unsymmetrical	871
Lenses, Voigtlander's	895, 896
Lenses, Voigtlander's Portrait Euryscope.....	903
Likeness of a Person—At-home Portraiture	154
Light—At-home Portraiture with Home Surroundings.....	125
Light Controlling—A Necessity	164
Light Controlling Factors, Two—At-home Portraiture.....	157
Light Controlling Screen for At-home Portraiture.....	193
Light Controlling Screen, Illustration of.....	Page 96
Light, Controlling the	293
Light, Controlling the—Plain Portrait Lighting.....	207, 208
Light, Diffused—Interior Photography	42
Light, Diffusing the	165
Light, Direction of—Interior Photography.....	104
Light, Dispersion of	580
Light, Effect of All Side	161
Light, Effect of All Top	162
Light Falling Properly	163
Light, First Steps Toward Controlling.....	159
Light for Interior Photography, Judging Strength of.....	62-66
Light for Interior Photography, Mathematical Method of Measuring	62-66
Light for Results—Rembrandt Lighting.....	308, 309
Light, Reflected	265

Light, Refraction of	577-579
Light, Source of—Location—Interior Photography.....	44
Light, Strength of	292
Light, The—Baby and Child Photography.....	389, 390
Light, Unobstructed—At-home Portraiture	189
Light, Visual and Actinic Rays of.....	581
Lighting—Baby and Child Photography.....	378, 386
Lighting—Broad Profile	347
Lighting Children's Portraits	407
Lighting Figures—Interior Photography	45
Lighting—Groups	445-448
Lighting—Interior Photography	40
Lighting, Modifications in	149
Lighting, Plain or Broad.....	167
Lighting, Rembrandt	168, 169
Lighting—Rembrandt Profile	348-371
Lighting, Softness in the	259
Lighting the Subject—Plain Portrait Lighting.....	212-216
Lightings, Plain (See Plain Lighting.)	
Lightings, Profile See Profile Lightings.)	
Lightings, Rembrandt (See Rembrandt Lightings.)	
Lips—Broad Profile Lighting	344
Location of Figures—Interior Photography	38
Long Neck—Posing Details	241
Long Prominent Noses—Posing Detail	237
Low Point of View—Interior Photography	36
Luxo Style "D" Flashlamp, Illustration of.....	Page 217
Magnesium and Flashlight Powders, Indoor Work with.....	472
Magnesium Flash-sheets	474
Magnesium Lamp	476
Magnesium Machine, Illustration of.....	Page 214
Magnesium Powder, Pure	475-477, 534-536
Magnification of a Telephoto System, To Find.....	934
Magnifications, Table of Telephoto.....	933
Main Points of Improvement in Lenses.....	768-777
Making Exposures—Interior Photography	60
Making General Preparations—At-home Portraiture.....	188-208
"Making Paper Dolls," Study No. 13, by Frances B. Johns- ton	Page 196
Manner of Diffusing a Lens.....	902
Margins Are Not Sharp with Rectilinear Lens, Why the....	654-656
Mathematical Method of Measuring Light—Interior Pho- tography	62-71
Measure Focal Length of Lens, To	614-617
Measuring Light for Interior Photography, Mathematical	

Method of	62-71
Meniscus Lenses	586
Methods of Igniting Flashlight Compounds.....	479
Mixture, Applying Backing	28
Mixture, Backing	27
Modifications in Lighting—At-home Portraiture.....	149
Money-making Opportunities—At-home Portraiture.....	147
Morrison Vignetter, Illustration of.....	Page 124
“Mother and Child,” Study No. 6, by Mary G. Huntsman... Page 83	
Mother and Children—Group—Illustration of.....	Page 201
Mouth—Posing Details	242, 243
Multi-Speed Shutter	705-711
Multi-Speed Shutter, Photographs Made with.....	Page 310
Nature and Use of Photographic Lenses, by S. Lawrence... 572-648	
Neck—Posing Details	240, 241
Negative Lenses	586
Newspaper Photography, The Lens for	736
Nichols' Flashlamp, Illus. of Sectional Front View of....	Page 223
Nichols' Flashlamp, Illus. of Sectional Rear View of.....	Page 224
Nichols' Junior Flashlamp, Illustration of.....	Page 222
Nichols' Professional Flashlamp, Illustration of.....	Page 222
Node of Emission	596, 606
Non-Halation Ortho Plates	25
Non-Halation Plates	23
Normal Perspective, Illustration of.....	Page 380
Normal Rembrandt Lighting	305
Noses—Posing Details	237-239
Number of Plates to Expose—At-home Portraiture.....	203
“Nydia,” Study No. 1, by Walker.....	Frontispiece
Obtaining Expression—Baby and Child Photography.....	396, 397
Obtaining Ideas for Posing—At-home Portraiture.....	156
Obtaining Softness—At-home Portraiture.....	178
Omitting the Unnecessary, Importance of.....	175
Operating-room of Stated Length, Determining Focal Length of Lens Suitable for.....	783-785
Optical Center of the Lens.....	606
Optical Qualities of Bausch & Lomb Tessar Lens.....	724
Ortho or Isochromatic Plates.....	24
Outdoors, Flat Effects	158
Out-of-doors, Illustration of At-home Portraiture.....	Page 189
Paper Backing, Black	29
Painted Background	185
Painted Background, Substitute for	198
Perspective, Illustration of Distorted.....	Pages 380, 381
Perspective, Illustration of Normal.....	Page 380

Perspective in Portrait, Distorted	913-915
Photographer, Lens for the Newspaper.....	736
Photographic Lenses—Their Nature and Use, by S. Lawrence	572-648
Photographic Shutters	689-719
Photographing Children Outdoors	416-421
Photographing Children Outdoors—Introduction.....	416-418
Photographing Children Outdoors—Developing	421
Photographing Children Outdoors—Securing Expression.....	420
Photographing Children Outdoors—Use of Hand Camera.....	419
Photographing Dining-rooms	79-85
Photographing Interiors of Residences.....	10-61
Photographing Interiors of Residences—Introduction.....	10-15
Photography, General Flashlight.....	472-485
Photography, Interior	10-123
Placing the Background—Plain Portrait Lighting	217
Placing the Flashlight	482
Placing the Subject—Broad Profile Lighting.....	339-341
Plain and Rembrandt Lightings, Illustrations for Suitable Profiles for	Page 157
Plain Background	184
Plain Background, Value of.....	183
Plain or Broad Lighting	167
Plain Portrait Lighting—At-home Portraiture.....	204-231
Plain Portrait Lighting—At-home Portraiture—Illustration of	Page 107
Plain Portrait Lighting—Attention to Details.....	211
Plain Portrait Lighting—Controlling the Light.....	207, 208
Plain Portrait Lighting—Developing.....	225, 226, 270
Plain Portrait Lighting—Difficulties.....	271-285
Background, Illuminating	275
Background Too Sharp.....	276, 277
Catch-light in the Eyes Too Large.....	281
Cheek, Heavy Shadow on Front of Shadow.....	278
Closing of Lips Too Tightly.....	283
Contrasty, Plate Developing	284
Developing Contrasty, Plate.....	284
Developing Flat, Plate	285
Diffusing High-lights	274
Diffusing Screen, Handling the.....	271
Eyes of Subject Appear Staring.....	282
Eyes Too Large, Catch-light in the.....	281
Flat, Plate Developing.....	285
Handling the Diffusing Screen.....	271
Heavy Shadow on Front of Shadow Cheek.....	278

High-lights, Diffusing	274
Illuminating Background	275
Lips Too Tightly, Closing of.....	283
Overcoming Reflection Caused by Sun Striking on the Window	279
Plate Developing Contrasty	284
Plate Developing Flat	285
Placing Reflector at Proper Angle.....	272, 273
Posing the Subject	280
Reflector at Proper Angle, Placing.....	272, 273
Sharp, Background Too	276, 277
Staring, Eyes of Subject Appear.....	282
Subject, Posing the	280
Sun Striking on the Window, Overcoming Reflec- tion Caused by	279
Plain Portrait Lighting—Exposure.....	220-224, 269
Plain Portrait Lighting—Flashlight Portraiture.....	508
Plain Portrait Lighting—Flashlight Portraiture—Floor Plan	Page 228
Plain Portrait Lighting, Floor Plan of.....	Page 103
Plain Portrait Lighting—Lighting the Subject	212-216
Plain Portrait Lighting—Placing the Background.....	217
Plain Portrait Lighting—Posing the Subject.....	209, 210
Plain Portrait Lighting—Position of the Camera.....	218
Plain Portrait Lighting—Position of the Head.....	260, 261
Plain Portrait Lighting—Practice Work	227-231
Plain Portrait Lighting—Proper Height of the Camera.....	219
Plain Portrait Lighting, Softness in	259
Plain Portrait Lighting—The Subject	204
Plano Concave Lenses	586
Plano Convex Lenses	586
Plastigmat Lens, Bausch & Lomb.....	756-761
Plastigmat Lens, Demonstration of Single Combination of	Page 331
Plastigmat Lens, Sectional View of Bausch & Lomb.....	Page 328
Plate and Field of the Lens, Relative Position of.....	603
Plate, To Ascertain the Angle Covered by Any Size.....	941
Plates, Backed	26
Plates, Developing Specially Prepared—Interior Photography.....	75-77
Plates, Non-halation	23
Plates, Non-halation Ortho	25
Plates, Ortho or Isochromatic	24
Plates to Expose, Number of—At-home Portraiture.....	203
Plates to Use for Interior Photography.....	21
Pneumatic Release	694

Point of View, Low—Interior Photography.....	36
Points to Be Considered—Broad Profile Lightings.....	337
“Portrait of a Child,” Study No. 4, by Fairman.....	Page 41
Portrait Euryscope Lenses, Voigtlander’s.....	903
Portrait Lens, Focal Length of.....	916, 917
Portrait Lens, Voigtlander’s Heliar.....	904-907
Portrait Lenses	897-921
Portrait Lenses, Bausch & Lomb	908-910
Portrait Lenses, Dallmeyer Patent.....	899-901
Portrait Lenses, Illustrations of.....	Pages 374-379
Portrait Lenses, Speed of.....	911, 912
Portrait Lenses, The Diffusing System for Bausch & Lomb.....	909, 912
Portrait Photography, Stops for.....	687
Portrait Unar Lens, Bausch & Lomb-Zeiss.....	908
Portraiture and Groups with Bausch & Lomb-Zeiss Tessar....	729
Portraiture, Atmosphere in.....	206
Portraiture, Definite Aim in.....	152
Portraiture, Distorted Perspectives in.....	913-915
Portraiture, Flashlight	486-521
Portraiture, Lens for	781
Pose—Broad and Profile Lighting.....	342
Pose of Figure	264
Posing Detail—Arms and Hands	233
Posing Detail—Eyes	244
Posing Details—At-home Portraiture	232-254
Posing Details—Catch-lights in the Eye.....	246
Posing Details—Hair	251-254
Posing Details—Height of the Chin.....	236
Posing Details—Mouth	242, 243
Posing Details—Neck	240, 241
Posing Details—Noses	237-239
Posing Details—Wrinkles in Drapery—Men.....	234
Posing Details—Wrinkles in Drapery—Women	235
Posing, Obtaining Ideas for—At-home Portraiture.....	156
Posing the Child	388
Posing the Hands—Children’s Portraits.....	404-406
Posing the Subject—Plain Portrait Lighting.....	209, 210
Position of Flashlamp	507
Position of the Body—Broad Profile Lighting.....	345, 346
Position of the Camera—Plain Portrait Lighting.....	218
Position of the Head—Plain Portrait Lighting.....	260, 261
Positive Lenses	586
Powder, Pure Magnesium	475-477, 534-536
Powders, Flashlight	473
Power of a Lens, What is Covering.....	660, 661

Practice Work—At-home Portraiture.....	138-141
Practice Work—Firelight Effects by Daylight.....	429-432
Practice Work—Flashlight Photography	484
Practice Work—Groups	453-456
Practice Work—Groups and Interiors by Flashlight.....	540
Practice Work—Interior Photography.....	85-95, 111
Practice Work—Plain Portrait Lighting	227-231
Practice Work—Profile Lightings.....	365-371
Practice Work—Rembrandt Lighting.....	322-325
Preface	Pages 5, 6
Preparing the Fuse for Flashlight Photography.....	481
Preparing the Window for At-home Portraiture.....	192
Preserve Lenses, How to.....	844-848
Principal Axis of the Lens.....	587
Principal Considerations—At-home Portraiture	130
Principal Focus of the Lens.....	606
Principal Requirements—Baby and Child Photography....	376, 377
Printing—Firelight Effects by Daylight.....	428
Process Lenses, Cooke	842, 843
Process Work, Bausch & Lomb-Zeiss Tessar Lens for.....	732
Profile, Improving, by Proper Lighting	353
Profile Lighting—Exposure	363
Profile Lighting, Rembrandt	348-371
Profile Lightings—At-home Portraiture.....	336-371
Profile Lightings, Broad—At-home Portraiture.....	336-347
Profile Lightings—Developing	364
Profile Lightings—Illuminating the Background.....	359
Profile Lightings—Practice Work.....	365-371
Profile Lightings—Shielding the Lens.....	362
Profile Lightings—The Reflecting Screen.....	360, 361
Profile Lightings—The View of the Face.....	355-358
Profile Lightings—Tipping the Head.....	354
Profile Portraits—Proper Subjects for.....	352
Profiles, Shape of.....	338
Projecting, Adjustment of Arc for.....	939
Projecting and Enlarging Lenses.....	937-947
Projecting, Triple System Condenser for.....	940, 941
Projection Lens, Illustration of Bausch & Lomb.....	Page 391
Projection Lenses, Determining Focus to Use for.....	944, 945
Projection Table	947
Projection Work, Illuminant for.....	938
Proper Height of the Camera—Plain Portrait Lighting.....	219
Proper Subjects for Profile Portraits.....	352
Proper View of the Face—Rembrandt Lighting.....	351
Proportions of Image to the Original, Relative Exposures	

for Varying	791-798
Protar Lens, Bausch & Lomb-Zeiss.....	739-755
Protar Lens, Sectional View of.....	Pages 323, 324
Protar Lens, Series IV, Bausch & Lomb-Zeiss.....	741
Protar Lens, Series V, Bausch & Lomb-Zeiss.....	742, 743
Protar Lens, Series VIIA, Bausch & Lomb-Zeiss.....	744-755
"Punishment," Study No. 7, by Helen W. Cook.....	Page 84
Purely a Matter of Speed (Anastigmat Lens).....	651
Pure Magnesium Powder.....	475-477, 534-536
Pyramidal Arrangement of Groups.....	435-437
Pyramidal Arrangement of Groups, Illustration of.....	Page 169
Rectilinear Lens Compared with Anastigmat.....	649-658
Rectilinear Lens, Why the Margins Are Not Sharp With....	654-656
Rectilinear Lenses, Curvature of Field With.....	657, 658
Reflected Light	265
Reflecting Screen	296-298
Reflecting Screen—At-home Portraiture.....	199
Reflecting Screen—Groups	452
Reflecting Screen—Profile Lighting.....	360, 361
Reflecting Screen—Rembrandt Lighting.....	314-317
Reflecting Screen, Use of.....	207
Reflection, Avoid—At-home Portraiture.....	190
Reflectors—Flashlight Portraiture	497-499
Reflex Camera Adapted to Interior Portraiture.....	560
Reflex Camera and Flashlamp, Making Exposure With.....	570
Reflex Camera, Combination of Daylight and Flashlight With..	561
Reflex Camera Compared With Twin Lens Camera.....	555, 556
Reflex Camera, Diagram of Electric Connection for.....	Page 252
Reflex Camera, Essential Features of.....	553
Reflex Camera, Examples of Work With.....	Page 249
Reflex Camera, Flashlight Equipment in Conjunction With....	562
Reflex Camera—Focusing Hood.....	557, 558
Reflex Camera, Illustration of Principle of.....	Page 316a
Reflex Camera in Conjunction With Flashlamp, by M. J. Shiels	552-571
Reflex Camera Ready for Instant Exposure.....	554
Reflex Camera With Electric Connection, Illustration of..	Page 250
Refraction, Angle of.....	577-579
Refraction, Illustration of.....	Page 258
Refraction of Light.....	577-579
Refractive Power of Glass.....	579
Relative Aperture of Lens.....	867
Relative Exposure for Varying Proportions of Image to the Original	791-798
Relative Position of Face and Body.....	263

Relative Position of Plate and Field, Illustration of.....	Page 272
Relative Position of Plate and Field of the Lens.....	603
Release for Making Flashlight Exposure, Electric.....	566
Release, Pneumatic	694
Rembrandt Lighting	168, 169
Rembrandt Lighting—Background	299, 300, 313
Rembrandt Lighting—Brief General Instruction.....	288-301
Rembrandt Lighting—Detailed Instruction—At-home Por- traiture	302-325
Rembrandt Lighting—Developing	319
Rembrandt Lighting, Definition of.....	289, 290
Rembrandt Lighting—Difficulties	326-335
Background	333
Contrast, Too Much.....	327
Detail in Shadows, Lack of.....	330
Diffusing High-lights	328, 329
Exposure, Judging Proper.....	331
High-lights, Diffusing	328, 329
Judging Proper Exposure.....	331
Lack of Detail in Shadows.....	330
Light, Securing Sufficient Top.....	326
Reflecting Screen	332
Room Too Narrow.....	335
Screen, Reflecting	332
Securing Sufficient Top Light.....	326
Shadows, Lack of Detail in.....	330
Shadow Side of Face, Too Much High-light on.....	334
Too Much Contrast.....	327
Too Much High-light on Shadow Side of Face.....	334
Top Light, Securing Sufficient.....	326
Rembrandt Lighting—Diffusing Experiment.....	310-312
Rembrandt Lighting—Diffusing High-lights.....	302-304
Rembrandt Lighting—Exposure	301, 318
Rembrandt Lighting—Flashlight Portraiture.....	509
Rembrandt Lighting—Flashlight Portraiture—Floor Plan.....	Page 229
Rembrandt Lighting, Floor Plan of.....	Page 136
Rembrandt Lighting, Illustration of Suitable Profiles for Plain and	Page 157
Rembrandt Lighting—Introduction	286, 287
Rembrandt Lighting, Normal.....	305
Rembrandt Lighting—Practice Work.....	322-325
Rembrandt Lighting—Proper View of the Face.....	351
Rembrandt Lighting—Reflecting Screen.....	314-317
Rembrandt Lighting—Special Illumination of the Shadows....	321
Rembrandt Portrait—Side View.....	320

Rembrandt Profile Lighting.....	348-371
Rembrandt Profile Lighting—Floor Plan.....	Page 155
Rembrandt Profile Lighting—Lighting.....	348
Rembrandt Profile Lighting—Proper View of the Face.....	351
Rembrandt Profile Lighting—Use Plenty of Light.....	349
Reproducing Character	166
Requirements—Interior Photography	71
Residences, Photographing Interiors of.....	10-61
Rest, Eye	247-250
Results, Light for—Rembrandt Lighting.....	308, 309
Retouching, Avoiding the Necessity of.....	176
Retouching, Character Destroyed by—At-home Portraiture....	151
Rotating Stops	671
Safety of Focal Plane Shutter.....	703
Schott & Genossen, Communication from.....	787-790
Schriever Universal Extra Rapid Lens.....	666-669
Screen, Controlling, for At-home Portraiture.....	195
Screen, Diffusing	294, 295, 306, 307
Screen, Diffusing Curtain on Controlling.....	195
Screen for At-home Portraiture, Light Controlling.....	193
Screen in Window, Hanging.....	196
Screen, Reflecting	296-298
Screen, Reflecting—At-home Portraiture.....	199
Screen, Use of Diffusing.....	207
Screen, Use of Reflecting.....	207
Sectional Front View of Nichols' Flashlamp, Illustration of	
	Page 223
Sectional Rear View of Nichols' Flashlamp, Illustration of	
	Page 224
Securing Expression—Photographing Children Outdoors.....	420
Selecting a Window—At-home Portraiture.....	188
Selection of Accessories.....	182
Selection of Lenses.....	778-786
Selection of View Point—Interior Photography.....	101
Series of Infants' Pictures, Illustration of.....	Page 169
Setting Must be Harmonious—At-home Portraiture.....	153
Shading the Lens—Flashlight Portraiture.....	500
Shadows, Illuminating—Interior Photography.....	105-107
Shadows, Special Illumination of the—Rembrandt Lighting....	321
Shape of Profiles.....	338
Sharp? When is an Image.....	599
Shielding the Lens—Flashlight Photography.....	483
Shielding the Lens—Profile Lighting.....	362
Shiels, M. J.—Reflex Camera in Conjunction With Flash-	
lamp	552-571

Short Neck—Posing Details.....	240
Short Stubby Noses—Posing Details.....	238, 239
Shutter, Advantage of the Focal Plane.....	559
Shutter, Bausch & Lomb Volute.....	693
Shutter, Behind-the-Lens	690
Shutter, Between-the-Lens	690, 692
Shutter, Distortion When Using Focal Plane.....	704
Shutter, Efficiency of.....	700, 701
Shutter, Goerz XL Sector.....	693
Shutter, Multi-Speed	705-711
Shutter, Safety of Focal Plane.....	703
Shutter, The Drop.....	690, 691
Shutter, The Focal Plane.....	690, 695-704, 718, 826, 827
Shutter, The Focal Plane, Illustration of.....	Page 316 <i>a</i>
Shutter, The Focal Plane, Principle of.....	718
Shutter to Use—Flashlight Photography.....	518, 519
Shutters, Accuracy of.....	702
Shutters, Illustration of.....	Page 309
Shutters, Iris Diaphragm.....	692, 693
Shutters, Photographic	689-719
Shutters, Some Beginners' Notes on Instantaneous.....	712-719
Shutters, Wollensak	692, 693, 719
Shutters, Wallensak, Illustration of.....	Page 316 <i>b</i>
Side Light, Effect of All.....	161
Side View, Rembrandt Portrait.....	320
Simply Arranged Dining-room, Illustration of a.....	Page 42
Single Combination of Lens, Demonstration of.....	Pages 325, 326
Single Combination of Plastigmat Lens, Demonstration of	Page 331
Size of Image, Ratio of Distance and.....	612, 613
Size of Lens.....	659
Smoke—Flashlight Photography	520
Softness in Plain Portrait Lighting.....	259
Softness, Obtaining	178
Some Beginners' Notes on Instantaneous Shutter.....	712-719
Source of Light—Location—Interior Photography.....	44
Space to be Illumined—Interior Photography.....	68, 69
Spacing—Baby and Child Photography.....	387
Special Development, Controlling Halation by—Interior Photography	96-112
Special Examples of At-home Portraiture.....	Page 69
Special Illumination of the Shadows—Rembrandt Lighting....	321
Spectrum, The	581
Speed of Lens.....	865-868
Speed of Lenses—How Determined.....	623-647

Speed of Lenses, Illustration of Relative.....	Pages 284, 285
Speed of Portrait Lenses.....	911, 912
Speed, Purely a Matter of (Anastigmat).....	651
Spherical Aberration	584
Spherical Aberration, Correction of.....	585
Spherical Aberration, Illustration of.....	Page 263
Stained Glass Windows, Exposure for.....	48
Statuette, Illustration of.....	Page 182
Statuettes	408-414
Stereoscopic Camera, Illustration of Goerz-Anschutz.....	Page 348
Stereoscopic Camera, The Goerz-Anschutz Folding.....	828
Stop for Architectural Photography.....	687
Stop for Interior Photography.....	687
Stop for Landscape Photography.....	687
Stop for Portrait Photography.....	687
Stop, The Larger the, the Better the Lens.....	682
Stop, The Largest.....	688
Stop, To Find the Focal Value of a.....	675
Stop, What, Shall I Use?.....	686, 687
Stopping Down the Lens—At-home Portraiture.....	257, 258
Stops, Comparative Sizes of.....	674
Stops—Flashlight Photography	512
Stops—Interior Photography	70
Stops or Diaphragms.....	670-688, 866
Stops, Three Uses of.....	673
Strength of Light.....	292
Stretching the Background.....	186, 187
Studio, Advantages of a.....	171
Studio Unnecessary	170
Study the Subject—At-home Portraiture.....	155
Subject, Placing the—Plain Portrait Lighting.....	205
Subject, Posing the—Plain Portrait Lighting.....	209, 210
Subject, Study the—At-home Portraiture.....	155
Subject, The—At-home Portraiture.....	200-202
Subject, The—Plain Portrait Lighting.....	204
Subject's Attention, Holding.....	249, 250
Subjects for Profile Portraits, Proper.....	352
Subjects Situated at Various Distances Rendered Sharp at the Same Time	683, 684
Substitutes for Painted Background	198
Suitable Profiles for Plain and Rembrandt Lightings—Illus- trations of	Page 157
Sun Shining on Windows—Interior Photography.....	99
Superiority of Anastigmat Lenses	648
Symmetrical Lenses	869, 870

Systems Compared, Diaphragm or Stop.....	676
Table of Single Condensing Lenses.....	941
Table of Telephoto Magnifications	933
Table, Projection	947
Technical Detail—Interior Photography.....	35
Telephoto Demonstration	Page 391
Telephoto Lens, Sectional View of.....	Page 388
Telephoto Lenses, Illustrations of.....	Pages 389, 391
Telephoto Magnifications, Table of.....	933
Telephoto System, To Find Magnification of a.....	934
Telephotography	922-930
Telephotography, Exposure in	935, 936
Temporary Background	174
Tessar Lens, An Incidental Advantage of the Bausch & Lomb-Zeiss	734
Tessar Lens, Bausch & Lomb-Zeiss.....	722-738
Tessar Lens, Bausch & Lomb-Zeiss Apochromatic.....	733
Tessar Lens, Definition of Bausch & Lomb-Zeiss.....	724
Tessar Lens for General Work, Bausch & Lomb-Zeiss.....	731
Tessar Lens for Process Work, Bausch & Lomb-Zeiss.....	732
Tessar Lens for Three-Color Work, Bausch & Lomb-Zeiss....	733
Tessar Lens, Illumination of Bausch & Lomb-Zeiss.....	725
Tessar Lens, Landscapes with Bausch & Lomb-Zeiss.....	730
Tessar Lens, Portraits and Groups with Bausch & Lomb- Zeiss	729
Tessar Lens, Rapidity of Bausch & Lomb-Zeiss.....	726, 727
Tessar Lens, Sectional View of Bausch & Lomb-Zeiss...Page	318
Tessar Lens, Series IC, Bausch & Lomb-Zeiss.....	735-738
Tessar Lens to Hand Camera, Application of Bausch & Lomb-Zeiss	728
Test for Astigmatism	589
Test Lenses, How to.....	850
“The Cup That Cheers,” Study No 10, by Mrs. M. S. Gaines	Page 158
Theory of Special Method of Developing.....	108
Three-Color Work, Bausch & Lomb-Zeiss Tessar for.....	733
Three Examples of Interior Photography.....	78-84
Three Uses of Stops, The.....	673
Time of Day—Interior Photography.....	41
Time of Day to Make Interiors.....	98
Tipping the Head—Profile Lighting	354
To Find Magnification of a Telephoto System.....	934
Top Light, Effect of All	162
Trial May Be Quite Valueless, A.....	685
Triple System Condenser for Projecting and Enlarging....	940, 941

Tripod for Interior Photography.....	20
Twin Lens Camera, Reflex Camera Compared with.....	555, 556
"Two Against One," Study No. 14, by Neary.....	Page 202
Two Light Controlling Factors—At-home Portraiture.....	197
Unar Lens, Bausch & Lomb-Zeiss Portrait.....	908
Under-exposure—Interior Photography.....	59
Universal Lens, Bausch & Lomb Extra Rapid.....	762
Universal Lens, Bausch & Lomb Rapid.....	763
Unobstructed Light—At-home Portraiture.....	189
Unsymmetrical Lenses	871
Use and Nature of Photographic Lenses—By S. Lawrence..	572-648
Use of Alkali—Interior Photography	109
Use of Celluloid	177
Use of Hand Camera—Photographing Children Outdoors....	419
Use Plenty of Light—Rembrandt Profile Lighting.....	349
Valueless, A Trial May Be Quite.....	685
Value of At-home Portraits	127-129
View of the Face—Profile Lightings.....	355-358
View of the Lens, Angle of.....	597
Vignetter, Illustration of Morrison.....	Page 124
Vignetter, Morrison	266-268
Visual and Actinic Rays of Light.....	581
Voigtlander Collinear Lenses.....	889, 890
Voigtlander Dynar Lens	891, 892
Voigtlander Euryscope Lens.....	896
Voigtlander Heliar Lens.....	894, 895, 904-907
Voigtlander Lenses	860-896
Voigtlander Lenses, Illustration of.....	Pages 371, 374, 375
Voigtlander Portrait Euryscope Lenses.....	903
Voigtlander Telephoto Lens, Illustration of.....	Page 389
Volute Shutter, Bausch & Lomb.....	693
Volute Shutter, Illustration of Bausch & Lomb.....	Page 309
Waterhouse Stops	671
What Is Covering Power of a Lens?.....	660, 661
What Plate Will the Lens Cover?.....	664
"What Stop Shall I Use?".....	686, 687
When Number Is Given for the <i>f</i> System, To Find the U.	
S. Number	680
Why an Anastigmat Is Desirable	649-665
Why the Margins Are Not Sharp with Rectilinear Lens....	654-656
Wide-Angle Lens.....	598, 663
Wide-Angle Lens, Goerz Dagor as a.....	819
Window for At-home Portraiture, Preparing the.....	192
Window, Hanging Screen in.....	196
Window Portraits, Illustrations of—At-home Portraiture..	Page 70

Window, Selecting a—At-home Portraiture.....	188
Windows Facing South, East or West Can Be Made Use of, How—At-home Portraiture	191
Windows Included in View—Interior Photography.....	34
Windows in View—Interior Photography.....	100
Windows, Sun Shining on—Interior Photography.....	99
Wollensak Shutters	692, 692, 719
Wollensak Shutters, Illustration of.....	Page 316 <i>b</i>
Wood or Leather, Blacking for.....	849
Working in Confined Positions—Interior Photography.....	61
Wrinkles in Drapery—Men.....	234
Wrinkles in Drapery—Women.....	235

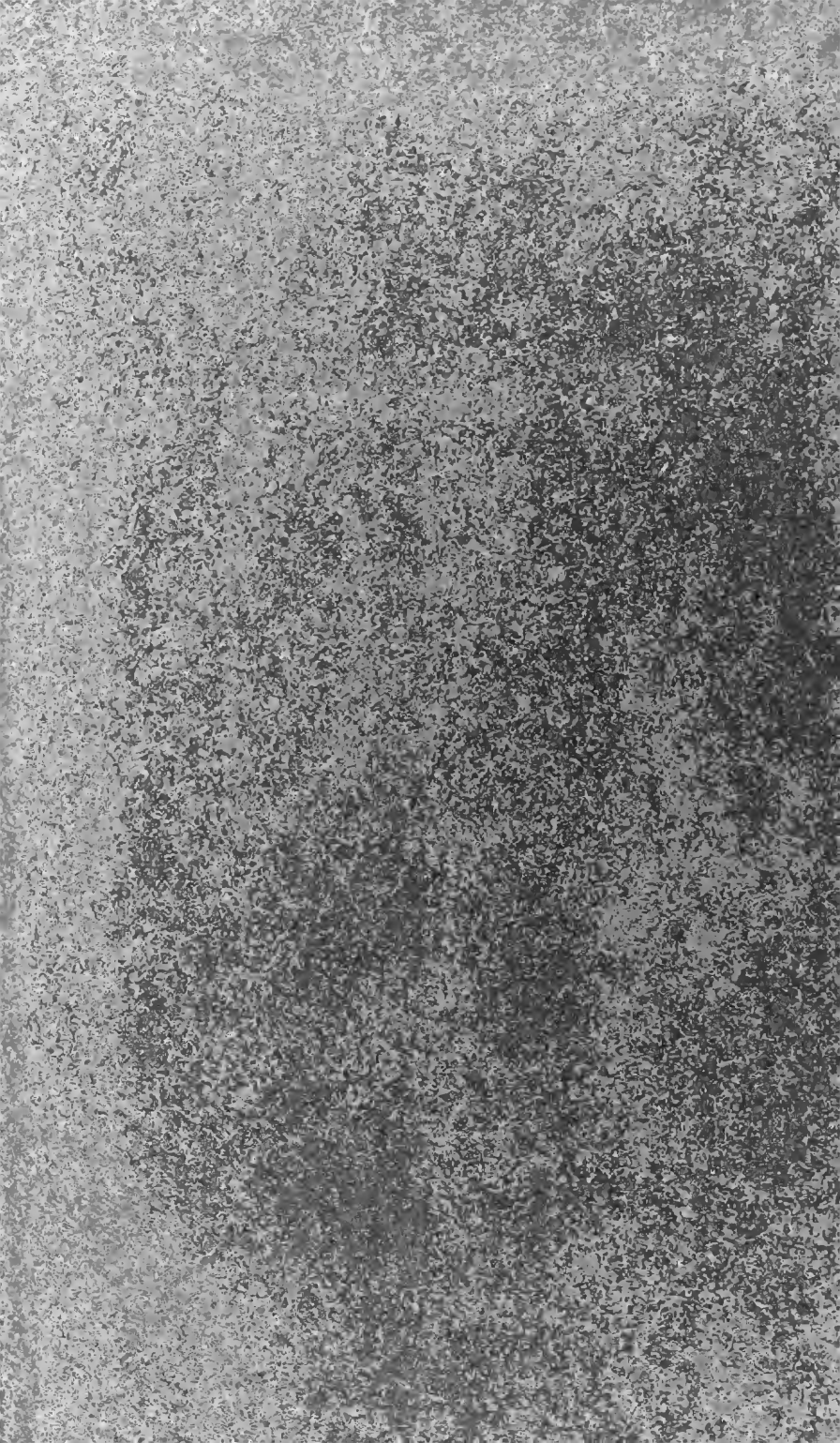

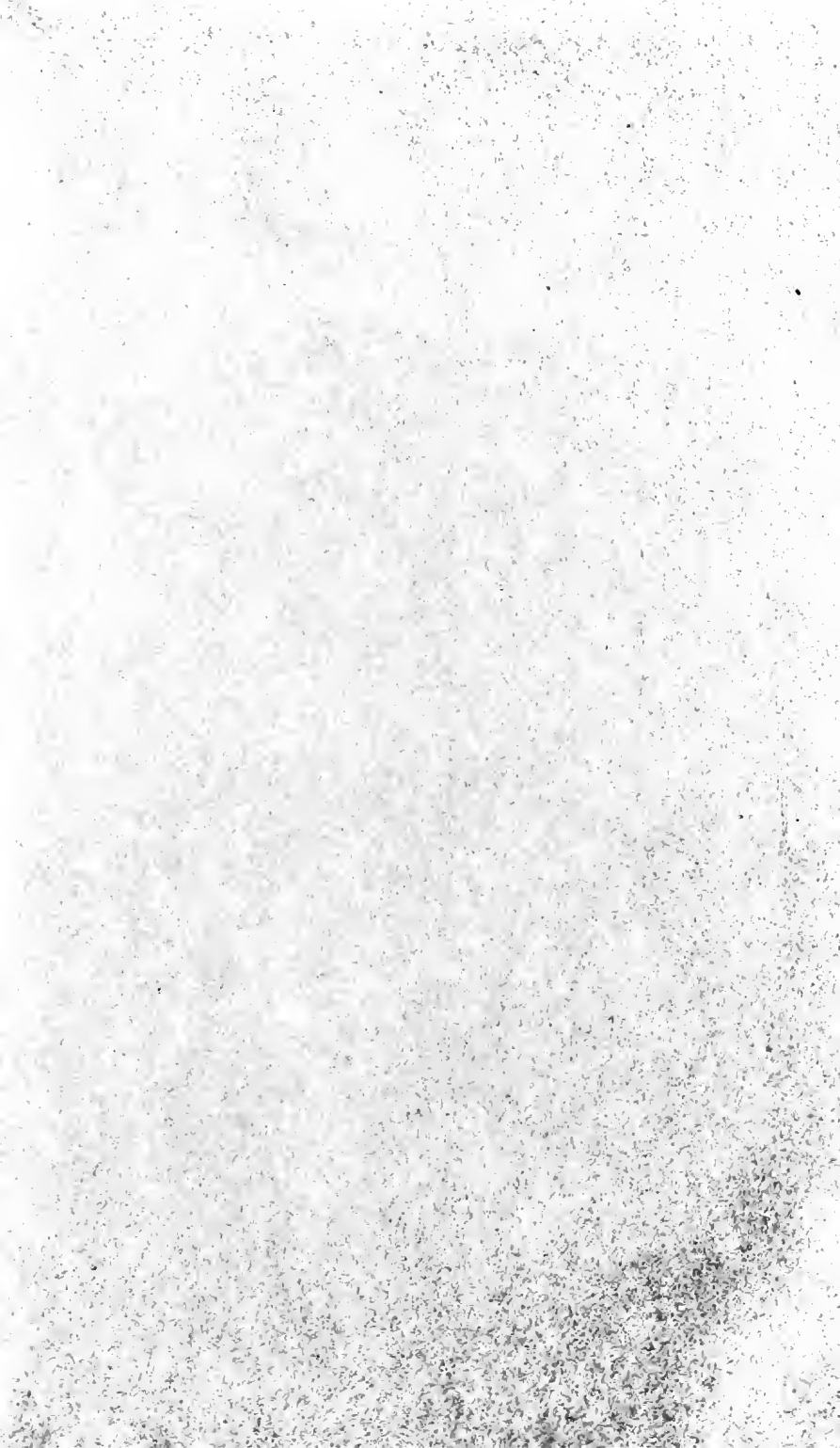



CANCELLED

University of California
SOUTHERN REGIONAL LIBRARY FACILITY
405 Hilgard Avenue, Los Angeles, CA 90024-1388
Return this material to the library
from which it was borrowed.

APR 13 1998



A 000 744 814 5

PLEASE
RETURN AS
SOON AS POS-
SIBLE since other
library borrowers may
want this book. You will
confer a favor by promptly
returning the book as soon as
you are through reading it, even
if your time has not expired. The
hearty cooperation of our readers and
their thoughtful consideration of the
rights of others is enabling the library to

