

A COMPREHENSIVE PLAN
FOR THE
EXTENSION OF THE SUBWAY SYSTEM
OF THE
CITY OF CHICAGO

INCLUDING PROVISION FOR THE
WIDENING OF E. AND W. CONGRESS STREET

EDWARD J. KELLY
Mayor
JAMES R. QUINN
Chairman, Committee on Local Transportation



CHARLES DE LEUW AND COMPANY, Consulting Engineers

R. F. KELKER, JR., Engineer, Committee on Local Transportation

DEPARTMENT OF SUBWAYS AND TRACTION

RALPH H. BURKE, Chief Engineer
PHILIP HARRINGTON, Commissioner

1930

ILLINOIS INSTITUTE OF TECHNOLOGY

LIBRARY



This book is due on the date shown.

Fines:

General Circulation: 10¢ per day.

Reserve Circulation: as posted.

F.35-1

DATE DUE

DEMCO 38-297

CLOSTX.HE4491.C4 C42x 1939
Chicago. Dept. of Subways
and Traction.
A comprehensive plan for the
extension of the subway

A COMPREHENSIVE PLAN

FOR THE

EXTENSION OF THE SUBWAY SYSTEM

OF THE

CITY OF CHICAGO

INCLUDING PROVISION FOR THE
WIDENING OF E. AND W. CONGRESS STREET



CHARLES DE LEUW AND COMPANY, Consulting Engineers

R. F. KELKER, JR., Engineer; Committee on Local Transportation

DEPARTMENT OF SUBWAYS AND TRACTION

RALPH H. BURKE, Chief Engineer

PHILIP HARRINGTON, Commissioner

Submitted to the Mayor and the City Council of
the City of Chicago, October 30, 1939

FRED KLEIN & COMPANY PRINTERS CHICAGO



Digitized by the Internet Archive
in 2010 with funding from
CARLI: Consortium of Academic and Research Libraries in Illinois

<http://www.archive.org/details/comprehensivepla00depa>





ADDRESS ALL COMMUNICATIONS TO THE COMMISSIONER

DEPARTMENT OF SUBWAYS AND TRACTION

CITY OF CHICAGO

20 NORTH WACKER DRIVE
TELEPHONE RANDOLPH 6440

EDWARD J. KELLY
MAYOR

PHILIP HARRINGTON
COMMISSIONER

TO THE HONORABLE,
THE MAYOR AND THE CITY COUNCIL,
OF THE CITY OF CHICAGO.

October 30, 1939.

GENTLEMEN:

In compliance with Paragraph (j), Section 9, Part I of the Subway Grant Agreement dated as of October 25, 1938 between the United States of America and the City of Chicago, there is transmitted herewith a comprehensive plan for the extension of the subway system, which includes provision for the widening of E. Congress Street and W. Congress Street from S. Michigan Avenue westward. A general pattern of the comprehensive local rapid transit plan herein contemplated is depicted on Figure "A" attached.

The plan proposes that the work of providing subways for the City of Chicago be divided into four financing and construction stages, of which the first is now in progress:

	<i>Subway Miles</i>	<i>Estimated Cost</i>
<i>1st Construction Stage</i>		
State Street Subway	4.41	75,750,000
Dearborn Street Subway	3.29	19,850,000
	7.70	\$ 45,600,000
<i>2nd Construction Stage</i>		
Congress Street Subway	0.90	\$ 7,300,000
Lake Street Subway	0.75	4,400,000
Washington Street Subway	0.95	5,400,000
Jackson Street Subway	1.00	6,300,000
	3.60	\$ 23,400,000
<i>3rd Construction Stage</i>		
Wells-Archer-Ashland Subway	11.20	\$ 59,200,000
14th Street Connection	0.61	3,600,000
Milwaukee Avenue Subway	4.65	22,200,000
Douglas Park Subway	2.34	11,000,000
	18.80	\$ 96,000,000
<i>4th Construction Stage</i>		
South Park Avenue Subway	2.00	\$ 10,100,000
Archer-Cicero Subway	6.12	29,600,000
North Avenue Subway	3.09	15,900,000
Belmont Avenue	3.31	17,300,000
Milwaukee Avenue Express	1.30	6,200,000
Crosstown Subways	4.20	21,200,000
Michigan Avenue Subway	0.38	1,700,000
	20.40	\$102,000,000
Total Subway Program	50.50	\$267,000,000

57648

The plan contemplates the construction of two-track subways, to be utilized for the operation of rapid transit trains. The exceptions to this general specification are the Jackson-Michigan-Washington loop, an underground street system designed for street car or bus operation and the single tube subway for express operation in Milwaukee Avenue between Logan Square and Paulina Street. The underground loop will make possible the removal of all east and west street car tracks in the central business district, a substantial contribution toward "thawing out" the existing street and bridge congestion in this most important traffic area.

The completion of the Lake Street and Congress Street subway extensions planned for construction immediately following the initial system will permit the removal of the Lake Street and Wabash Avenue sides of the elevated loop.

Following these subways, if the plan is adhered to, the construction of the Wells Street subway as recommended will make possible the removal of the remainder of the elevated loop.

In general, the plan recognizes the desirability of doing away with elevated rapid transit operation as rapidly as it becomes feasible to replace these needed services with equal below surface facilities. With this in mind, all extensions of rapid transit service are planned as subways, even though intervening sections of elevated railway may of necessity remain temporarily.

The scope of this rapid transit system for local transportation purposes may be appreciated by the fact that the combined elevated-subway-suburban railroad system will provide rapid transit to 92 per cent of the population of the city by providing service to those residing within one mile of its lines, or a coverage comprising 78 per cent of the total area of the city. When properly coordinated with a unified local distributor transit system it should provide adequate and necessary transit service for all.

The cost of the completed subway system comprising 101 miles of single tube is placed at \$267,000,000, or approximately \$72 per capita (1940 population). Philadelphia has spent on subways \$150,000,000 or \$75 per capita, and New York City over \$1,000,000,000 (\$133 per capita) with a program under way which contemplates another billion. Similar instances could be cited in London, Paris, Berlin and many other foreign cities. Compared with these, the program outlined is not over-ambitious for Chicago if it is to hold its place as one of the great cities of the world.

The local transportation requirements of any large city of today present the problem of making adequate provision, not only for public carrier service, but also for already large and ever increasing volumes of private automobiles and motor trucks. The latter types of traffic may be divided into two groups according to character of street use, viz: fast moving through traffic and slower moving or local distributor service. The interests of economy, safety and freedom of movement for both will be best served by attaining the maximum possible degree of segregation of these two types of private operation.

It is this problem of making adequate provision for large volumes of private traffic as well as for users of common carrier service, that makes "superhighways"

as necessary for the segregation of fast moving automotive traffic as subways are needed for the rapid transportation of the public car rider. Nor can we dispense with either, in the hope that the other will provide all the relief we need.

As a step in recognition of the need of such facilities for improved automotive movement, the Subway Grant Agreement recognizes the possibility of joint construction of a portion of a west side superhighway in conjunction with the necessary work of completing a subway connection between the Dearborn Street subway and the Metropolitan Branch of the Rapid Transit system. This joint subway and highway construction would be located along the general line of Congress Street (extended) west of Dearborn Street.

As required by the Grant Agreement, the comprehensive plan here submitted includes a study and plan for such a superhighway from S. Michigan Avenue westward, including a suggestion for a logical route and type of construction west of the actual subway zone to the city limits.

Studies were made along the general line of Congress Street and also an alternate route along Polk Street. An alternate plan embracing a further extension of the Congress Street subway west to Kedzie Avenue as part of the depressed Congress Street highway development is also presented.

In general, the recommended plan contemplates eight wide traffic lanes. Between Wells Street and Racine Avenue the structure would be elevated, while a depressed type of highway is suggested for the reach from Racine Avenue to the city limits. In the terminal area east of Wells Street, the improvement is planned for 120 foot width at street grade, with the widening between State Street and Michigan Avenue confined for the present to cutting back sidewalks. Alternate designs for the necessary bridge over the Chicago River are also included.

The design of the Congress Street superhighway incorporates all the features of a "limited-access" thoroughfare including suitable entrances and exits, separation of opposing traffic streams, complete elimination of cross traffic and traffic signals, with no left turns, no pedestrians and no parking. Adequate ramps, modern lighting and wide landscaped areas on either side are contemplated. The design fully recognizes the desirability of enhancing values of areas traversed by the improvement.

It is estimated that this improvement will have a capacity of 6,000 vehicles per hour in a single direction, as compared with a liberal forecast of 4,000 per hour as the maximum initial use, or an excess capacity of 50 per cent. A regulation fixing minimum as well as maximum speeds is generally recognized as conducive to maximum efficiency as well as safety on this type of highway improvement and should be established for operation in this case.

The use should be limited to high speed passenger vehicle traffic including express but not local buses. The transfer of these types of vehicles to the superhighway will relieve the surface streets of substantial volumes of traffic, thereby providing freer use of their roadways for local and commercial vehicles.

The total estimated cost of this west side superhighway (Michigan Avenue to the city limits) is estimated at \$31,465,000. From Wells Street to the city

limits the cost is approximately \$26,465,000. In the subway zone only (Dearborn Street to Throop Street) the cost is estimated at \$12,200,000. Included in all estimates are land, buildings and construction costs. Of the total estimated cost, approximately 54 per cent is for construction, and 46 per cent for land and buildings.

SUMMARY

This report presents a comprehensive pattern of subway extensions which should be constructed as financial ability permits and as the need for expansion of the city's rapid transit facilities is indicated.

It is my opinion that the full usefulness of the Initial System of Subways now under construction will not be realized until the subway connections to the Metropolitan and Lake Street branches of the Rapid Transit System are constructed. These two extensions are estimated to cost \$11,700,000. It is recommended that every effort be made to provide the necessary financing of these subway extensions at the earliest possible time.

It is also recommended that the suggested east and west subways in Washington and Jackson Streets be provided at as early a date as feasible, inasmuch as these "underground streets" will provide improved service to approximately 156,000,000 people annually, will give the west side car riders access to the east side of the loop district and to the Lake Front, will provide subway connections between four major railroad stations, and will go far toward relieving loop congestion through the removal from the streets of all east and west street car tracks. The estimated cost of these two subways is \$11,700,000.

The other subway extensions indicated in this report are needed in greater or less degree and should be built as rapidly as feasible, in the interest of extending rapid transit facilities to the greatest possible number.

In the preparation of this plan and report, the details of which were prepared by Charles DeLeuw and Company, Consulting Engineers, appreciation is expressed of the assistance and advice freely given by R. F. Kelker, Jr., Engineer of the Committee on Local Transportation, and by the engineering staffs of the various departments of the City, the County and State Highway departments, the Chicago Park District, the Chicago Plan Commission and the Regional Planning Association.

Inasmuch as the requirements of the Grant Agreement require submission of this report to the Administrator (F.W.A.) before November 1, 1939, it is requested that the report and plan be received and referred to the appropriate committee for consideration, and that authority be granted to submit it at once to the Administrator (F.W.A.), advising him that it is being considered but has not as yet been approved by the City Council nor by the Mayor.

Respectfully submitted.



*Commissioner of Subways
and Traction*

limits the cost is approximately \$26,465,000. In the subway zone only (Dearborn Street to Throop Street) the cost is estimated at \$12,200,000. Included in all estimates are land, buildings and construction costs. Of the total estimated cost, approximately 54 per cent is for construction, and 46 per cent for land and buildings.

SUMMARY

This report presents a comprehensive pattern of subway extensions which should be constructed as financial ability permits and as the need for expansion of the city's rapid transit facilities is indicated.

It is my opinion that the full usefulness of the Initial System of Subways now under construction will not be realized until the subway connections to the Metropolitan and Lake Street branches of the Rapid Transit System are constructed. These two extensions are estimated to cost \$11,700,000. It is recommended that every effort be made to provide the necessary financing of these subway extensions at the earliest possible time.

It is also recommended that the suggested east and west subways in Washington and Jackson Streets be provided at as early a date as feasible, inasmuch as these "underground streets" will provide improved service to approximately 156,000,000 people annually, will give the west side car riders access to the east side of the loop district and to the Lake Front, will provide subway connections between four major railroad stations, and will go far toward relieving loop congestion through the removal from the streets of all east and west street car tracks. The estimated cost of these two subways is \$11,700,000.

The other subway extensions indicated in this report are needed in greater or less degree and should be built as rapidly as feasible, in the interest of extending rapid transit facilities to the greatest possible number.

In the preparation of this plan and report, the details of which were prepared by Charles DeLeuw and Company, Consulting Engineers, appreciation is expressed of the assistance and advice freely given by R. F. Kelker, Jr., Engineer of the Committee on Local Transportation, and by the engineering staffs of the various departments of the City, the County and State Highway departments, the Chicago Park District, the Chicago Plan Commission and the Regional Planning Association.

Inasmuch as the requirements of the Grant Agreement require submission of this report to the Administrator (F.W.A.) before November 1, 1939, it is requested that the report and plan be received and referred to the appropriate committee for consideration, and that authority be granted to submit it at once to the Administrator (F.W.A.), advising him that it is being considered but has not as yet been approved by the City Council nor by the Mayor.

Respectfully submitted,



*Commissioner of Subways
and Traction*

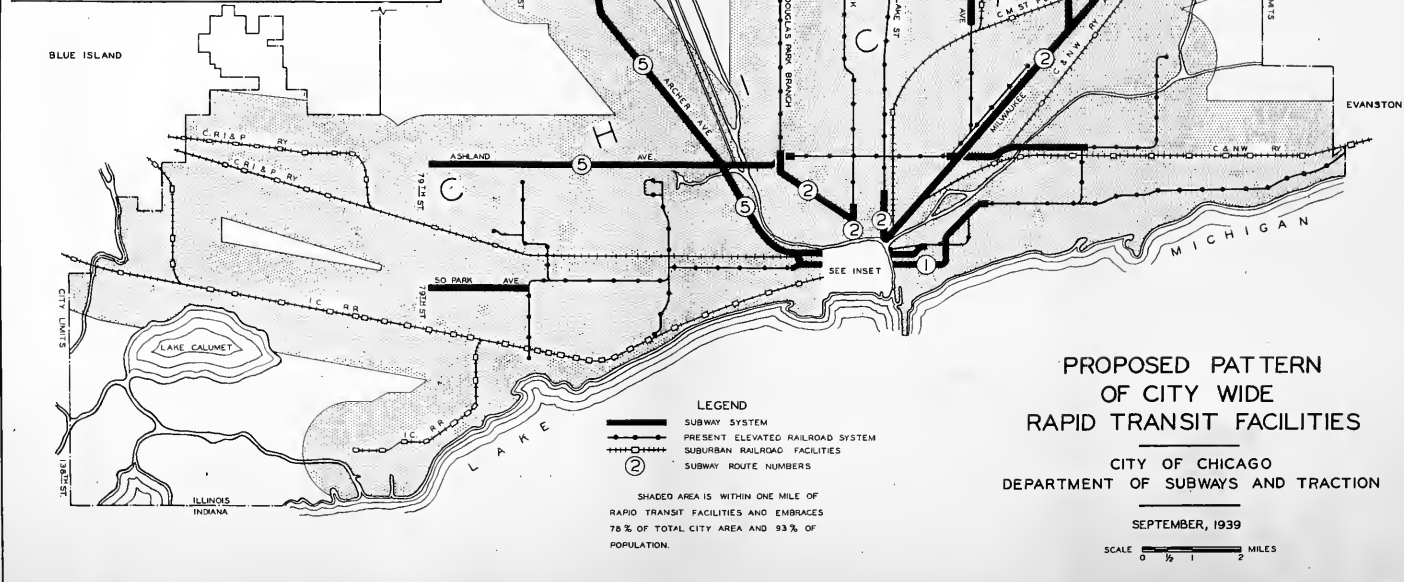
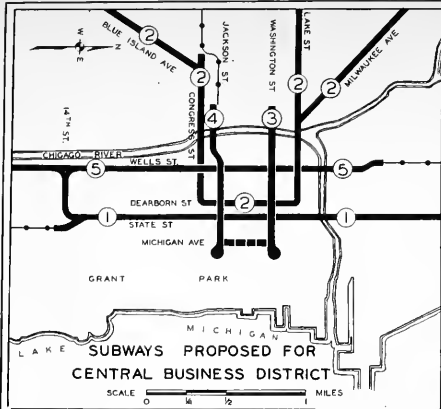


FIGURE A

CONTENTS

	PAGE
LETTER OF TRANSMITTAL	3
SUMMARY OF REPORT	11
Subway Extensions—Second Stage	12
Subway Extensions—Third Stage	13
Subway Extensions—Fourth Stage	14
Subways Related to Modernization of all Local Transportation	17
Widening of Congress Street	17
Alternate Combination Subway-Highway Plan	20
Polk Street Alternate Route	20
The Initial Use and Capacity of the West Side Superhighway	21
Estimates of Cost	21

PART I

A COMPREHENSIVE PLAN FOR THE EXTENSION OF THE SUBWAY SYSTEM

GENERAL DEVELOPMENT OF CHICAGO	22
EXTENSIONS OF THE SUBWAY SYSTEM	24
<i>The Extension of the Subway System—Second Stage</i>	25
Dearborn Street Subway—Congress Street Extension	25
Lake Street Subway Extension	26
Street Car Subways	28
Washington Street Subway	29
Jackson Street Subway	29
<i>Future Subway Extensions—Third Stage</i>	30
Wells Street Subway—Route No. 5	30
Milwaukee Avenue Extension	31
Douglas Park Connection	32
<i>Future Subway Extensions—Fourth Stage</i>	32
South Park Avenue Extension	32
Archer-Cicero Avenue Extension	33
North Avenue Extension	33
Belmont Avenue Extension	33
Milwaukee Avenue Subway—Express Track	34
Crosstown Subways	34
Michigan Avenue Subway Connection	36
THE RELATION OF SUBWAYS TO THE MODERNIZATION OF CHICAGO'S LOCAL TRANSPORTATION	36
Suburban Railroads	37
Future Rapid Transit Operations	38

PART II

WIDENING AND IMPROVEMENT OF CONGRESS STREET

Previous Proposals for the Congress Street Improvement	41
Specifications for a West Side Superhighway	43

	PAGE
THE CONGRESS STREET IMPROVEMENT IN THE SUBWAY ZONE	
Michigan Avenue to State Street	44
State Street to Wells Street	45
Wells Street to Canal Street	47
Canal Street to Throop Street	52
A SUGGESTION FOR A SUPERHIGHWAY DEVELOPMENT WEST OF SUBWAY ZONE	53
Depression of Express Roadways Suggested	54
Alignment	55
Efficiency of Improvement as Planned	56
Ramps and Connections	58
Intersecting Streets	59
Parallel Service Drives	61
Traffic Control	63
Express Bus Operation	63
Construction Details	64
Lighting	64
Estimates of Cost	65
AN ALTERNATE PLAN FOR THE WEST SIDE SUPERHIGHWAY INCLUDING DEPRESSION OF RAPID TRANSIT TRACKS BE- TWEEN HALSTED STREET AND SACRAMENTO BOULEVARD	
Express Roadway Layout	67
Congress Street Subway Connection	68
Metropolitan Elevated Railroad Tracks	68
Douglas Park Branch	68
Garfield Park Branch	69
Alternate Alignment—Racine Avenue to Sacramento Boulevard	69
Intersecting and Connecting Streets	70
Estimates of Cost	70
ALTERNATE POLK STREET ROUTE FOR WEST SIDE SUPERHIGH- WAY	
General Description of Improvement	71
Relative Efficiency of Polk Street Alternate	73
Estimates of Cost	73

APPENDIX I

THE INITIAL USE AND THE CAPACITY OF THE PROPOSED WEST SIDE SUPERHIGHWAY

PRESENT WEST SIDE TRAFFIC	75
Hourly, Daily and Monthly Variations in Traffic	76
Traffic Volumes	80
Origin and Destination	82
Speeds	83
DATA ON ROADWAY CAPACITY	84
Speeds—Various Data	84
Data on Capacity and Use	86
Intersection Movements	93

	PAGE
NORMAL CAPACITY OF SUPERHIGHWAY FACILITIES	98
Unobstructed Traffic Lane	98
Partially Obstructed Traffic Lane	99
Ramps	100
ESTIMATED INITIAL USE OF SUPERHIGHWAY	101
DISTRIBUTION OF TRAFFIC IN AND NEAR THE CENTRAL BUSINESS DISTRICT	107
Automobile Storage and Parking Facilities	107

APPENDIX II

ESTIMATES OF COST OF SUBWAY EXTENSIONS AND THE
WEST SIDE SUPERHIGHWAY

SUBWAY EXTENSIONS

Dearborn Street Subway—Congress Street Extension	111
Lake Street Subway Extension	111
Washington Street Subway	112
Jackson Street Subway	112
Two-Track—High Level Subway—Section Between Stations	112
Two-Track—High Level Subway—With Side Platforms	113
Single Track Tunnel—Between Stations	113
Two-Track Tunnel with 18 Foot Center Platform	113
Typical Mezzanine Station	114
Typical High Level Subway Station with Side Platforms (52 Feet Long— Including Track Section)	114
Single Track Tunnel—Between Stations (in Difficult Ground Conditions)	115
Two-Track Tunnel—With 22 Foot Center Platform (in Difficult Ground Conditions)	115

WEST SIDE SUPERHIGHWAY

Michigan Avenue to State Street (Roadway Widening Only)	116
State Street to Clark Street	117
Clark Street to Wells Street	117
Wells Street to the Chicago River	118
Chicago River Bridge	119
Canal Street to Desplaines Street	119
Desplaines Street to Throop Street	120
Throop Street to Ashland Avenue	121
Ashland Avenue to Damen Avenue	122
Damen Avenue to Western Avenue	123
Western Avenue to California Avenue	124
California Avenue to Kedzie Avenue	125
Kedzie Avenue to Cental Park Avenue	126
Central Park Avenue to Pulaski Road	127
Pulaski Road to Kostner Avenue	128
Kostner Avenue to Cicero Avenue	129
Cicero Avenue to Laramie Avenue	130
Laramie Avenue to Central Avenue	131
Central Avenue to Austin Boulevard (Columbus Park)	131

TABLES

	PAGE
Travel Time Between Various Focal Points Coordinated with Modernized Feeder and Distributor Routes	38
Inbound Subway Traffic After Completion of Comprehensive Plan—Maximum 30-Minute Period	39
Counts of Traffic at the Congress Street Entrances to the Post Office	48
Estimates of Traffic Flow on Eastbound Roadway of West Side Superhighway—Maximum 30-Minute Period	57
Summary of Present 16-Hour Traffic Movements on North and South Streets Which Will Be Terminated at Service Drives Along the Proposed West Side Superhighway	60
Present Traffic on Streets Parallel and Adjacent to the Proposed West Side Superhighway	62
Summary of Estimate of Cost of West Side Superhighway	65
Estimate of Cost of Alternate Plan—West Side Superhighway and Rapid Transit Track Depression	70
Estimate of Cost—West Side Superhighway—Polk Street Alternate	74
Summary of Continuous Counts Made by Chicago Park District—1936-1937—At Michigan Avenue and Monroe Street	77
Summary of Continuous Counts Made by Chicago Park District—1936-1937—At Sacramento, Washington and Warren Boulevards	78
Summary of Continuous Counts Made by Chicago Park District—1936-1937—At Jackson and Ashland Boulevards	79
Speeds—Average Data for Uncongested Roads	84
Average and Maximum Motor Vehicle Speeds—Detroit, Michigan	85
Average Motor Vehicle Speeds—State Wide Highway Planning Survey	86
Maximum Observed Rates of Traffic Flow per Average Lane—One Direction	87
Usage of Curb Lane During Maximum Hour in Detroit, Michigan (Parking Prohibited)	88
Maximum Hourly Motor Vehicle Traffic per Lane, Detroit, Michigan	88
Vehicle Flow on Wilmot Street Bridge—Pittsburgh, Pennsylvania (One Lane)	89
Traffic Volume per Lane, Typical Pittsburgh Intersections	89
Maximum Traffic Volumes in Chicago	91
Observed Maximum Hourly Flows—Selected Crossings, Parkways and Streets—In the City of New York	92
Delays Caused by Turns—Pittsburgh	95
Average Time Required for Various Movements of Passenger Cars Through Intersections—Central Business District, Chicago	96
Estimates of Additions and Deductions of Traffic to and from the Proposed West Side Superhighway Based on Existing Passenger Vehicle Movements During Maximum 30-Minute Period Inbound	102-105
Summary of Data on Ramps and Connections	106
Number of Passengers Entering and Leaving Central Business District—Chicago—Typical Week-day in May—7:00 A. M. to 7:00 P. M.	108
Automobile Storage and Parking Facilities (1936) Estimated Capacities—12-Hour Period	109

FIGURE- NUMBER	FIGURES (Follow Appendix II)
A.	Proposed Pattern of City Wide Rapid Transit Facilities
1.	Comprehensive Plan for Extension of the Subway System and Forecast of Population Distribution—1950
2.	Extension of the Subway System—Second Stage
3.	Extension of the Subway System—Third Stage
4.	Extension of the Subway System—Fourth Stage
5.	Relation of Rapid Transit Lines as Proposed to Centers of Industry, Commerce, Recreation and Residence in the City of Chicago
6.	Plan and Profile—Proposed Subway Terminal at Logan Square
7.	Congress Street Improvement—Proposed Plaza East of the Chicago River
8.	View of Congress Street from Jefferson Street
9.	View of Congress Street Near Sangamon Street
10.	View East on Congress Street Near Racine Avenue
11.	View West on Congress Street Near Racine Avenue
12.	View of Congress Street Near Paulina Street
13.	View of Van Buren Street Near Central Park Avenue
14.	Perspective of West Side Superhighway Between Garfield Park and Columbus Park
15.	Perspective of West Side Superhighway Near Typical Overpass Structure
16.	View Between Gladys Avenue and Van Buren Street—Looking West from Lavergne Avenue
17.	Flow Chart of Existing Inbound Passenger Vehicle Traffic—Canal Street to Austin Boulevard
18.	Flow Chart Indicating Redistribution of Existing Inbound Traffic on Completion of Proposed West Side Superhighway—Canal Street to Austin Boulevard
19.	Flow Chart of Existing Inbound Passenger Vehicle Traffic in Central Business District
20.	Flow Chart Indicating Redistribution of Existing Inbound Traffic on Completion of Proposed West Side Superhighway—Central Business District
21.	Perspective of Alternate Combination Superhighway-Subway Plan Near Rapid Transit Station
22.	View of Polk Street—Looking East from Jefferson Street
23.	Half Hour Variations in Traffic—Typical Weekday
24.	Daily Variations in Total 24-Hour Traffic
25.	Monthly Variations in Total 24-Hour Traffic
26.	Time-Distance Curves—Passenger Car Movements at Street Intersections
27.	Suggested Traffic Control on Congress Street—Canal Street to State Street
28.	Plat of Medical Center Showing Existing Development
29.	Perspective of Alternate Combination Superhighway-Subway Plan East of Racine Avenue
30.	Perspective of Elevated Section of Superhighway West of Clinton Street

PLANS

(Follow Figures)

SHEET
NUMBER

1. Title Sheet
2. General Plan—Subway System
3. General Plan in the Central District
4. Plan and Profile—Congress St. Extension to Dearborn St. Subway
5. Plan and Profile—Lake Street Subway
6. Plan and Profile—Washington Street Subway
7. Plan and Profile—Jackson Street Subway
8. Typical Sections—Low Level Subway
9. Typical Sections—High Level Subway
10. Typical Low Level Station
11. Typical High Level Station with Side Platforms
12. Plan and Section—Clinton Street Station—Lake Street Subway
13. General Plan—Congress Street Improvement
14. A Suggested Plan—State Street to Michigan Avenue
15. Plan and Profile—Wells Street to State Street
16. Plan and Profile—Clinton Street to Wells Street
17. Plan and Profile—Halsted Street to Clinton Street
18. Plan and Profile—Aberdeen Street to Halsted Street
19. Plan and Profile—Throop Street to Aberdeen Street
20. Structure—Desplaines Street to Canal Street
21. Typical Underpass Through Solid Fill Section
22. Reconstruction Through La Salle Street Railroad Station
23. W. Congress Street Lift Bridge
24. W. Congress Street Fixed Bridge
25. W. Congress Street Bascule Bridge
26. Plan and Profile—St. Louis Avenue to Throop Street
27. Plan and Profile—Columbus Park to St. Louis Avenue
28. Typical Cross Sections
29. Typical Overpass Structure
30. Detail—Wolcott Avenue to Marshfield Avenue
31. Detail—Kedzie Avenue to Sacramento Boulevard
32. Detail at Garfield Park
33. Detail—Extension to City Limits
34. Detail at Columbus Park
35. Alternate—Plan and Profile—Halsted Street to Clinton Street
36. Alternate—Plan and Profile—Aberdeen Street to Halsted Street
37. Alternate—Plan and Profile—Throop Street to Aberdeen Street
38. Alternate—Plan and Profile—Kedzie Avenue to Throop Street
39. Alternate—Typical Cross Sections
40. Alternate—Detail Ogden Avenue to Ashland Boulevard
41. Alternate—Detail—Kedzie Avenue to Sacramento Boulevard
42. Alternate—Detail—Elevated Inclines
43. Plan Showing Property to Be Acquired
44. General Plan Showing Alternate Alignments

October 27, 1939.

MR. PHILIP HARRINGTON,
COMMISSIONER OF SUBWAYS AND TRACTION
CITY OF CHICAGO.

DEAR SIR:

Pursuant to your instructions we have completed the plans required by Paragraph (j), Section 9, Part I of the Grant Agreement dated as of October 25, 1938 between the United States of America and the City of Chicago. These plans are transmitted herewith together with a report thereon, which is summarized as follows:

SUMMARY OF REPORT

The Subway Grant Agreement between the City of Chicago and the Federal Government requires that the city submit

"a comprehensive plan for the extension of the subway system, satisfactory to the Administrator and in such detail as he may require, to include provision for the widening of E. Congress Street and W. Congress Street from S. Michigan Avenue westward and for the construction of a subway in W. Congress Street, from S. Dearborn Street westward; and shall, in the event that the State of Illinois shall make available for such construction the proceeds of the motor fuel tax collected from users in the City of Chicago, or an adequate part thereof, or other monies adequate for said purpose, have proceeded promptly with such construction and carried on the same as rapidly as possible according to plans and specifications approved by the PWA Commission."

The time for submission of this plan was originally fixed at July 1, 1939 but has since been extended to November 1, 1939. The required plan has been completed and is submitted herewith, together with a report thereon.

The report deals first with the general development of Chicago, describing certain existing conditions relative to distribution of and growth in population, industry and commerce pertinent to transportation planning. The relationship of the proposed new superhighway program to the modernization, improvement and extension of local common carrier transit facilities is also analyzed, and the great necessity for both subways and superhighways is developed in some detail.

In planning the extensions of the subway system the present day departure from construction of additional elevated railroads was recognized. While many elevated structures now utilized in Chicago's rapid transit system will form useful parts of that system for years to come, the subway extensions herein proposed recognize the constant public demand for the removal of certain of these structures which have for years disfigured and partially blockaded traffic on downtown streets. In view of their adverse effect on property values and city development, both here and in other large metropolitan centers, no new elevated railroad structures are proposed in this report.

The comprehensive plan for the extension of the subway system—see Figure A—is divided into four stages, the first of which is now under construction and includes:

Route No. 1—the State Street Subway, and

Route No. 2—the Dearborn Street Subway (incomplete).

Subway Extensions—Second Stage

As a second step, it is proposed to complete the Dearborn Street subway, Route No. 2, by an extension westward along Congress Street from the south end of the Dearborn Street subway as constructed in the initial project to a connection with the metropolitan elevated railroad structure near Halsted Street. An extension westward is also proposed along Lake Street from a connection with the initial subway at Milwaukee Avenue and Canal Street to a connection with the Lake Street elevated structure near Racine Avenue. The completion of the Dearborn Street subway, Route No. 2, through the building of the two proposed extensions will provide a substitute for and permit the removal of the Wabash Avenue and Lake Street sections of the existing elevated loop structure.

Other important new subway facilities included in the second stage are Route No. 3 and Route No. 4—high level subways (in reality underground streets) which may be used for street car operation along Washington Street and Jackson Street—see Figure 2. These subways will extend from connections to the existing tunnels under the Chicago River to terminal loops in Grant Park east of Michigan Avenue passing over the north and south low level subways in State and Dearborn Streets.

These units will be of enormous benefit to street traffic in the congested loop district. Through the removal of street car tracks from east and west streets in the entire area east of Clinton Street between Lake and Harrison Streets, there will be released for the use of other vehicles the equivalent of more than four miles of additional traffic lanes. Substantial increases in capacity of seven west side bridges over the Chicago River will also be effected. The speed of street car travel will be more than doubled. West side passengers will be delivered to points east of Dearborn Street with direct access to the Lake Front and to the Illinois Central suburban stations. Suburban passengers from four railroad stations will be provided with efficient means of traveling east and west in the central area. All of this will be a direct and substantial benefit to some 156,000,000 riders who now travel east and west in the downtown district each year.

The estimated cost of the subways included in the second stage of development is summarized below. These estimates include station finish and escalators but exclude other equipment and connections to elevated structures. They also include the cost of right-of-way except that located between the north and south lines of Congress Street as proposed to be opened.

<i>Route Number</i>	<i>Subway</i>	<i>Estimated Cost</i>	<i>Miles</i>
2	Dearborn Street Subway— Congress Street Extension	\$ 7,300,000	0.90
	Lake Street Extension	4,400,000	0.75
3	Washington Street Subway	5,400,000	0.95*
4	Jackson Street Subway	6,300,000	1.00*
	Total	\$23,400,000	3.60

* Includes existing river tunnel.

Subway Extensions—Third Stage

Included in this group of subway extensions are projects which would be useful additions to the city's transit system now, but which are not as urgently needed as those included in the second stage—see Figure 3. The units projected for third stage development are briefly described as follows:

Wells Street subway—Route No. 5—would connect with the Northwestern elevated railroad structure near Chicago Avenue, and extend south along Wells Street, Franklin Street (extended) Archer Avenue and Ashland Avenue to a terminal at 79th Street and Ashland Avenue. Through the loop district this route is planned as a low level subway, passing under Routes 3 (Washington Street) and 4 (Jackson Street) but rising to pass over Route 2 (Dearborn Street subway) at Congress Street. This subway, when completed, would provide downtown terminal connections for a portion of the service from the north side which may be through routed to the southwest side. It will also provide *new* rapid transit facilities in the southwest section of the city and direct rapid transit service to numerous intermediate important centers. Its completion would also permit the removal of the remainder of the elevated union loop structures in Wells and Van Buren Streets. An important part of this subway project is the suggested connection between Route No. 1—the State Street subway—and the Wells Street subway—Route No. 5—along the line of 14th Street, providing for looping or turning back trains at that location. This connection would also permit a through operation from the south terminal of the Wells Street subway—Route No. 5 (79th Street and Ashland Avenue) to the north side, through either the State Street subway—Route No. 1 or the Wells Street subway—Route No. 5.

A second much needed rapid transit extension of Route No. 2 planned in the third stage is a subway northwest in Milwaukee Avenue from a connection with the existing rapid transit railroad at Logan Square to Foster Avenue. This subway will extend rapid transit service to a growing and important section of the city.

Improved service to the area served by the Douglas Park branch is planned through a new subway extending from a connection with the proposed Congress Street subway extension of Route No. 2 in the vicinity of Desplaines Street southwest along Blue Island Avenue and under private property to a connection with the Douglas Park elevated railroad structure near Wood and Cullerton Streets.

This connection would provide a more direct route and greatly improve service between the Douglas Park elevated and the downtown district.

The third stage of development of the comprehensive plan as above outlined includes some 18.8 miles of double track subway, involving a total estimated expenditure at present day prices for right-of-way and construction (exclusive of equipment) of approximately \$96,000,000.

Subway Extensions—Fourth Stage

In this group of subways, projected for future construction when the traffic demand warrants the investment, are extensions of rapid transit service mainly in portions of the city where substantial increases in population are expected to occur in the future, and where further development should be encouraged—see Figures 1 and 4. The extensions proposed for this stage of development are as follows:

1. *South Park Avenue.* A subway extending from the Jackson Park elevated railroad along South Park Avenue to a terminal at 79th Street and South Park Avenue.
2. *Archer-Cicero extension.* This is an extension of Wells Street subway—Route No. 5—along Archer Avenue and Cicero Avenue to a terminal at 63rd Street and Cicero Avenue.
3. *North Avenue extension.* This is a subway extension of the Humboldt Park branch of the elevated railroad system extending west along North Avenue from the present terminal to a terminal at Central and North Avenues.
4. *Belmont Avenue extension.* A subway along Belmont Avenue from a connection with the Milwaukee Avenue subway to a terminal at Belmont and Oak Park Avenues.
5. *Milwaukee Avenue subway.* This consists of the construction of a single track tube to provide three rapid transit tracks between the Ashland-Division station and Logan Square, permitting the operation of a reversible express service during the morning and evening rush hours through this section.
6. *Crosstown subway routes.* Two subways are proposed. The first, extending from a connection with the Wells Street subway—Route No. 5—near Ashland and Archer Avenues north along the line of Ashland Avenue to a connection with the Douglas Park elevated structure near Cullerton Street; and

The second, a subway extending north from the Metropolitan elevated structure near Division and Paulina Streets along the general line of Wood Street to a connection with the Ravenswood elevated structure near Roscoe Street.

When completed, facilities will thus be provided for through rapid transit service along a crosstown route extending from the Ravenswood elevated line—Lawrence Avenue on the north to Ashland Avenue and 79th Street on the south, connecting and articulating the city's radial rapid transit service to the northwest, west and southwest.

7. *The Michigan Avenue subway*—which consists of a two-track connection along Michigan Avenue between Washington and Jackson Streets, to interconnect and improve delivery for subway Routes No. 3 and 4.

This fourth stage in the development of the city's comprehensive subway system totals 19.1 miles of double track subway and 2.6 miles of single track tube, a total of 40.8 miles of rapid transit track. The total estimated cost of this construction at present day prices including right-of-way but excluding subway equipment is approximately \$102,000,000. The entire plan is shown on Figure A, which also shows the areas which will be within one mile of rapid transit facilities upon completion of the comprehensive program. The sections not included within these one mile zones total 47.4 square miles in area and contain an aggregate of but 254,000 or less than 8 per cent of the total population of the city (1930 census).

The entire comprehensive subway plan provides 51.5 miles of subway construction and 100.4 miles of single track at a total cost of approximately \$267,000,000. This is a large sum by comparison with Chicago's previous expenditures for rapid transit but compared with more than \$400,000,000 expended for highway improvement in Chicago during the past twenty-five years and with expenditures elsewhere, this is not an extravagant figure. The City of Philadelphia, with a population of less than 2,000,000, has invested approximately \$150,000,000 in subways. New York's investment in subways is over one billion dollars, in spite of which that city recently announced a program calling for an ultimate investment of another billion dollars.

Subways Related to Modernization of all Local Transportation

The report also deals with the coordination of the extended rapid transit system with a modernized and unified city-wide surface transit system. The practicability of utilizing rapid transit lines for long haul traffic and their close coordination with surface feeder and distributor routes is dealt with in some detail. Utilization of existing suburban railroad facilities as a part of the city-wide urban transit scheme is also discussed. Analysis is made of the probable traffic on the several portions of the rapid transit system in and near the terminal district, giving effect to the completion of all portions of the proposed comprehensive rapid transit plan.

Widening of Congress Street

As required by the terms of the grant agreement with the Federal Government, plans for the widening of Congress Street, from Michigan Avenue westward, are also submitted. As preliminary to the preparation of these plans, various proposals heretofore advanced for the development of a major thoroughfare along the line of Congress Street were examined in detail. Consideration was also given to recent trends in the planning and construction of superhighways and in particular the recent recommendations of Mr. Thomas H. MacDonald, Chief of the Public Roads Administration, Federal Works Agency.

The plans are prepared in some detail for that section of the project in the vicinity of and affected by the extension westward of the Dearborn Street subway. A suggested general plan west of this location, extending to the city limits, is sub-

mitted in less detail to indicate the logical development of a complete west side superhighway.

The complete segregation of local and through traffic by limiting the use of superhighways to fast moving passenger vehicles between the west city limits and the downtown terminal area is contemplated. The plans also incorporate all of the features required for an efficient limited access thoroughfare including suitable entrances and exits, separation of opposing traffic streams, complete elimination of pedestrians and parking from the express roadway area as well as the elimination of left turn or other crossing movements; all of which has been proven by experience both in Chicago and elsewhere to be necessary for safe and convenient express traffic movements. The improvement also is planned with adequate spaces between express roadways and abutting property, to be suitably landscaped and flanked with parallel service roadways and sidewalks, all in such a way as to constitute an improvement rather than a detriment to the neighborhoods in the vicinity of the superhighway.

The improvement in the downtown terminal area east of Wells Street is planned at street grade. A thoroughfare 120 feet in width is recommended with divided roadways accommodating 4 traffic lanes in each direction. It is suggested that the widening of Congress Street between State Street and Michigan Avenue be deferred until the necessity for additional capacity in that location is more definitely proven.

Between Wells Street and Racine Avenue an elevated structure is planned with one intermediate intersection at grade at Canal Street. East of the Post Office three express traffic lanes in each direction are planned and west of Canal Street—four express lanes in each direction. The improvement utilizes the existing two 40 foot roadways through the Post Office building just east of Canal Street. Preliminary plans for a new Congress Street bridge over the south branch of the Chicago River, prepared by the City Bridge Division, showing studies of three alternate types, are incorporated in the plans.

The acquisition of all of the private property between Wells Street, Congress Street, Lomax Place and the Chicago River is planned to provide facilities for convenient distribution of traffic to Market Street (Wacker Drive), Franklin Street and Wells Street. Congress Street will pass over Market and Franklin Streets and ramp down to normal street level at Wells Street. Twenty-four foot ramps on each side of the express roadways will provide for traffic to or from Franklin and Market Streets.

When and if adopted as a superhighway route, the initial construction which will provide the greatest benefit should include that portion extending from Wells Street at least as far west as Garfield Park, to include most of the subway zone and provide serviceable connections to the west.

West of the subway zone, or between Racine Avenue and the city limits, the construction of a depressed highway is suggested. Through this section two express roadways 48 feet in width, divided by an 8 foot center strip, would be flanked by

parkways, service drives and sidewalks and centered in rights-of-way varying from 225 feet to 400 feet in width. Alignment of the entire thoroughfare is planned in such a way as to minimize the taking of costly and useful buildings and to eliminate unnecessary costs. For this reason the improvement is shifted north from Congress Street and located just south of Van Buren Street between Paulina Street and Garfield Park. West of Garfield Park, the recommended location is even farther north, occupying a strip of land between Van Buren Street and Gladys Avenue.

Thorough studies were made of the probable initial use and ultimate capacity of the superhighways as planned, and the report contains an extended discussion of the prospective use and capacity of the several sections of the express roadways, as well as the various ramps and connections. Based on existing traffic flow on west side streets in the two mile section between Chicago Avenue and Roosevelt Road, maximum traffic on the superhighway will be found at Ashland Avenue, where the maximum one-way volume will approximate 4,000 vehicles per hour. The volume of traffic gradually decreases from the maximum point at Ashland Avenue, both to the east and to the west, so that both at Canal Street as well as at Cicero Avenue traffic will be reduced to approximately 2,500 vehicles per hour. It is conservatively estimated that the ultimate capacity of the superhighway as planned will be a total of 6,000 vehicles per hour in a single direction, so that the improvement will have capacity for handling an increase of 50 per cent above the existing volumes of traffic.

The design of ramps and connections is such as to insure ample capacity at all points and sufficient reservoir space to prevent lines of standing vehicles backing up in either the express roadways or roadways of intersecting streets. Some 40 overpasses are planned for intersecting streets providing direct cross roadways for more than 93 per cent of the existing total north and south cross traffic at the superhighway location.

Experience has developed the fact that express highway facilities of this character should be devoted exclusively to high speed passenger vehicle traffic. Use of such roadways for mixed traffic results in inefficient use of the facilities. The establishment of minimum as well as maximum speeds is recommended. By reason of the transfer of through passenger vehicle traffic to the superhighway, surface streets will be relieved of substantial volumes of traffic, thereby providing freer use of their roadways for local and commercial vehicles. The operation of express bus service may be permitted on superhighways and clearances are planned to accommodate such mass transit facilities.

The total estimated cost of the west side superhighway as planned is \$31,465,000. Included in this total is the entire cost of the right-of-way including the section between Dearborn and Halsted Streets to be used jointly for the subway and highway. Of the total estimated cost, approximately 54 per cent is the cost of construction and 46 per cent the estimated cost of land and buildings. A comparison of this cost with that involved in the State Highway Department's proposal of 1935 (superhighway mostly depressed) and in the Committee on West

Side Superhighway's report of 1938 (superhighway mostly elevated) may be made by including only those sections between Wells Street and the west city limits. Both of the earlier proposals included grade separations at major street intersections only, with a substantial number of intermediate intersections at grade requiring traffic signal control. As against the estimated cost of \$26,465,000 for constructing this suggested plan from Wells Street to the city limits, the 1938 project was estimated at \$24,254,000 and the 1935 state plan at \$21,260,000. In view of the fact that the plans submitted herewith provide substantially increased widths of right-of-way, superior design of ramps and connections, fewer closures of cross streets, improved and safer facilities for pedestrians, elimination of traffic signals and wider express roadways, it would appear that the relatively small increase in total cost is more than warranted.

Alternate Combination Subway-Highway Plan

An alternate plan has been prepared for the Congress Street subway extension and superhighway, broader in scope and consequently more costly, but with a number of advantages as compared with the plan described above. The alternate plan contemplates the extension of the subway westward in an open cut so as to permit the removal of the existing Garfield Park elevated structure throughout the entire section from Racine Avenue to Sacramento Boulevard. It would permit the installation of a third track for west side express service east of Kedzie Avenue, provide new and modern rapid transit stations properly spaced, located on a wider right-of-way through the mid-city section with resulting benefit both to property and motorists. This plan, which is described in detail in the report, involves a total cost from Wells Street to the city limits of \$33,970,000, or \$7,505,000 more than estimated for the original plan just described. However, it removes more than three miles of elevated railroad structure and substitutes three miles of additional subways for the west side providing express service from the loop to Kedzie Avenue at an increase in cost which is *less than half* of the cost of subways which would provide equal rapid transit facilities.

Polk Street Alternate Route

A study was made of an alternate location south of Congress Street, using an alignment along the general line of Polk Street. It was found that a terminal east of the Chicago River along the Polk Street location was impracticable due to existing railroad and property development, but that the Congress Street location east of the river could be coupled with a location along Polk Street west of the river at a saving in cost of \$825,000. However, the Polk Street alternate using the Congress Street easterly terminal has disadvantages in that the alignment is necessarily inferior and the location west of the river is south of the east and west traffic movement, particularly where it must be deflected to a location south of Taylor Street to avoid the medical center development between Hermitage and Damen Avenues. The total cost of a west side superhighway located on Congress Street between

Michigan Avenue and Canal Street and along the general line of Polk Street from Canal Street to the city limits is \$30,640,000.

The Initial Use and Capacity of the West Side Superhighway

Detailed engineering studies covering all phases of this problem are covered in considerable detail in Appendix I. The somewhat elaborate discussion of various controversial points was considered advisable in view of the extended arguments relative to certain questions of superhighway design in this area.

Estimates of Cost

Estimates of cost, both of subways and superhighways are set forth in Appendix II. These cost estimates would be somewhat liberal if the work were to be constructed immediately, as they include allowances for contingencies in view of the uncertainties of future trends in labor and material costs.

Respectfully submitted,

CHARLES DE LEUW & COMPANY,
Consulting Engineers

PART I

A COMPREHENSIVE PLAN FOR THE EXTENSION OF THE SUBWAY SYSTEM—GENERAL DEVELOPMENT OF CHICAGO

The vast amount of discussion and thought recently devoted to the changes in standards of living and to the shifting developments in large metropolitan centers suggests consideration of present day trends of industry, commerce and housing as a preliminary to transportation planning. Here in Chicago there has been endless discussion concerning the so-called "blighted" areas, which are those sections close in to the central business and manufacturing district—formerly devoted to residential use—which have been penetrated by industrial and commercial establishments so as to result in depreciating the value of these districts for residences and a complete stoppage of residential building construction—a process of gradual decay.

This situation is by no means unique in Chicago. This same evolution of use and depreciation of land values in areas surrounding the central district has been and is now taking place in almost every large metropolitan center in the United States. The mass movement of workers from these close-in areas now partially given over to industry has been accelerated by the ever increasing development in and use of the private automobile, which permits families to shift from crowded apartments in congested districts to relatively open spaces, either in the outskirts of the city or in suburban communities, where they can enjoy the advantages of single family dwellings at no great increase in living expenses.

This situation is a challenge to city planners. No single remedy will cure it entirely. An amendment of zoning regulations so as to more closely confine industry to areas best adapted to its needs from the viewpoint of rail connections, accessibility to employees, cost of land and taxes; and similarly to restrict the percentage of lands in which commercial buildings are permitted, will go a long way to insure the preservation and prosperity of the residential districts.

That there is a need for modern, well designed, multiple family dwellings in these close-in districts has been proven by the success attending the limited number of housing projects constructed in recent years in such areas, both in Chicago and in other large cities. Given the cooperation of intelligent planning of zoning regulations, modern housing developments, parks and playgrounds, arterial streets and superhighways, together with adequate and convenient local transportation—the evolution of the so-called "blighted" areas into well rounded, properly proportioned urban communities can be accomplished.

Much has been said also with respect to the tendency towards the ruralization of industry and the decadence of large cities by reason thereof. Recent analyses of the figures compiled by the United States Census Bureau for 1920 and 1930 showed that the rate of population increase in the City of Chicago in that decade

was 25 per cent, as compared with 32 per cent for the remainder of the Chicago district, 17 per cent for the State of Illinois and 16 per cent for the continental United States. In the same decade the number of wage earners in the City of Chicago as compared to the total in the entire Chicago metropolitan area decreased from 77.2 per cent to 73.2 per cent, whereas the number of establishments increased from 84.2 per cent to 86.0 per cent.

In Chicago, as elsewhere, the tendency toward centralization of industry has taken place through the shifting of plants from locations with high land values and taxes and other restrictive conditions, to the locations in the outer sections of the city or in the suburban districts adjacent thereto. A survey of new industrial locations in the Chicago region, exclusive of the City of Chicago, shows that 90 per cent of such new establishments, as measured by the total number of employees, were in the area adjacent to the City of Chicago, whereas only 10 per cent were found in the more remote sections of the metropolitan district located outside of Cook County and the north half of Lake County, Indiana. It is significant that practically all of the new establishments were located within the confines of the Chicago switching district. It is concluded that there will continue to be an accelerated industrial development in the suburban area immediately surrounding the City of Chicago, but there is no evidence that it will be accelerated to the point where industry in corporate Chicago will actually decrease in importance.

In the 1937 report on "A Comprehensive Local Transportation Plan for the City of Chicago" forecasts of the future population of Chicago and the Chicago metropolitan district, as prepared by the technical staff of the Illinois Bell Telephone Company and the Chicago Regional Planning Association, were described and recommended for use as a basis for planning transportation facilities. These estimates forecast a population for the City of Chicago of 4,200,000 for 1950 and 4,500,000 for 1960. The distribution of population, in accordance with the 1950 forecast, has been charted by the staff of the Committee on Local Transportation and is reproduced herewith—see Figure 1. On this population spot map is indicated the comprehensive plan for the extension of the subway system recommended herein. This chart, representing as it does the best available estimates of residential development throughout the entire City of Chicago in 1950, provides a visual exhibit through which the necessity for certain of the proposed subway extensions becomes evident.

Despite the increasing development of commercial and industrial centers throughout the corporate area of Chicago, and despite the gradual disappearance of various forms of retail trading in the central district resulting from the increase in attractive and efficient shopping centers in other locations; the importance of the great central business district, as measured by day time population, has been relatively stable. Cordon counts of passengers entering and leaving the central business district, which have been made from year to year since 1926, are summarized in Appendix 1. These counts were made at the Chicago River bridges

on the north and west and at Roosevelt Road on the south. In view of the fact that the activities formerly confined to the loop district have been shifting in some volume to the near north and west side sections just beyond the river, it appears that the day time population of the central district is still increasing.

Enabling legislation recently passed provides for the financing of a comprehensive system of superhighways to be built jointly by Chicago, Cook County and the State of Illinois. Such thoroughfares, providing as they will for the segregation of the through from the local traffic, and extending from the periphery of the city to the downtown district, will be of enormous benefit in the improvement of safety and in facilitating traffic movements generally. However, such superhighways will not eliminate the need for the extension of the subway system. It would be financially impossible to build sufficient highway facilities to permit the elimination of public transportation.

Of the 839,000 persons transported to the central business district on a typical week-day of the most recent cordon count (January, 1939), 245,000 or about 29 per cent were delivered in passenger automobiles. To provide facilities for the other 71 per cent—now transported in suburban and elevated trains, street cars and buses—would require enlarging the existing street system to three times the present capacity. This is manifestly impracticable.

Many other factors should be considered such as the relatively lower cost of public transportation, its convenience and dependability and finally the fact that most members of the average family must necessarily depend on common carrier service. Much has been said thoughtlessly of the gradual disappearance of the street car, bus and rapid transit train. However, we should not lose sight of the fact that the local transportation systems in Chicago are daily serving 2,700,000 riders and that this number will increase with subways and modernized transit. This is significant in view of the notable improvement in passenger automobiles and the almost complete failure to improve Chicago's public transportation. Thus it may be concluded that, while superhighways are needed and will be built, the need for subway extensions and modernization of all local transit facilities is fully as urgent.

In the plans for the extension of the subway system presented herein, study has been made of the basic information summarized above, as well as of all of the numerous investigations and reports which have been made on local transportation for the City of Chicago during the past thirty years. Advantage has been taken in particular of the numerous investigations carried on preliminary to the 1937 report on "A Comprehensive Local Transportation Plan for the City of Chicago."

EXTENSIONS OF THE SUBWAY SYSTEM

The general plans (Sheets 2 and 3) and the diagrams on Figures 2, 3 and 4 show four suggested stages of development of the proposed comprehensive subway plan, as follows:

1. The subway system—*first stage*. This is the "initial system of subways" now under construction as a P.W.A. project, III. 1891-F and includes—
Route No. 1—a two-track subway on Clybourn Avenue, Division Street and State Street extending from connections to the existing elevated railroad structures just north of North Avenue and just south of Roosevelt Road, and
Route No. 2—a two-track subway on Milwaukee Avenue, Lake Street and Dearborn Street extending from a connection to the existing elevated railroad structure just northwest of the intersection of Ashland Avenue and Division Street to a temporary terminal at the south line of Van Buren Street.
2. The subway system—*second stage* (see Figure 2). These include subway extensions proposed for early construction and are the units required to supplement and complete the subways now under construction in the central business district, and are—
Route No. 2—Congress Street extension.
Route No. 2—Lake Street extension.
Route No. 3—Washington Street subway.
Route No. 4—Jackson Street subway.
3. Subway extensions—*third stage* (see Figure 3). In this group are placed subway extensions, the need for which is evident at this time, based on present city development, but which are not necessary to complete the initial project.
4. Subway extensions—*fourth stage* (see Figure 4). In this group will be found proposals for future subway construction to serve outlying sections of the urban area, based on estimates of future growth and the prospective transit needs of the several districts.

THE EXTENSION OF THE SUBWAY SYSTEM—SECOND STAGE

Dearborn Street Subway—Congress Street Extension

This two-track subway is one of the extensions required to complete the Dearborn Street Subway—Route No. 2, now under construction (see Sheet 4). It will connect with the completed subway along Dearborn Street at the south line of Van Buren Street and extend southwesterly along Dearborn Street and private property to Congress Street extended at Clark Street, thence west along the line of Congress Street extended and partly under private property to a connection to the four-track Metropolitan elevated structure of the Chicago Rapid Transit Company near Halsted Street.

The completion of this unit, together with the Lake Street extension described hereafter, will permit the through routing of rapid transit trains from the Garfield Park and the Douglas Park branches through terminal subways to the Lake Street, Humboldt Park and Logan Square branches of the elevated system. In view of the fact that the traffic from the northwest branches and from Lake Street

is now substantially greater than that from the Garfield Park and Douglas Park branches, it is necessary to provide facilities near the south end of the central business district for turning back the unbalanced portion of the traffic from the north-west side and Lake Street.

It is proposed to provide such turnback facilities through the installation of a single track high level loop under the proposed Congress Street plaza west of Wells Street with suitable track connections just beyond the west end of the station platform as shown on Sheet 4. A plan and section typical of the low level subway proposed at this location is shown on Sheet 10. An island platform 22 feet in width is contemplated. It is proposed to center this rapid transit station under the LaSalle Street railroad station in such a way as to permit direct connection between the subway station and the track level of the railroad terminal if the companies should desire to cooperate.

A second station is proposed on this subway extension between Canal and Clinton Streets. Such a station will provide for delivery to the U. S. Post Office building, the Union Station, the Burlington office building and other points in this rapidly developing area. The Canal-Clinton station for Congress Street will be constructed in tunnel at low level and is planned with an island platform 18 feet in width.

Typical sections of both low level and high level subways which may be utilized in various sections of this and other extensions are shown on Sheets 8 and 9. By lowering the grade of the roadway of Halsted Street approximately 2 feet and raising the roadway of Desplaines Street some 4 feet it is possible to build the necessary subway-elevated incline on a gradient of 3.17 per cent without closing any streets. The necessary changes in grade can be carried on in connection with the Congress Street opening and widening project at a minimum of disturbance to nearby property.

The estimated cost of this extension as shown in detail in Appendix II is \$7,300,000. This includes an allowance for right-of-way on the curve between the west line of Dearborn Street and the east line of Clark Street and north of the proposed north line of Congress Street. The cost of the right-of-way along the line of Congress Street which would be required for subway purposes only in the area between Clark Street and Halsted Street is included in the estimates of cost of the Congress Street widening improvement.

Lake Street Subway Extension

This is the second of the two-track subway extensions required to complete the Dearborn Street Subway—Route No. 2, now under construction (see Sheet 5). It extends from a connection with the completed subway in Lake Street at Milwaukee Avenue west along private property and Lake Street to a connection with the two-track Lake Street elevated structure of the Chicago Rapid Transit Company near Racine Avenue.

Stations will be provided between Clinton Street and Jefferson Street and at Halsted Street to provide delivery for rapid transit passengers to the near west side district. The station at Halsted Street will be the conventional mezzanine low level type with an 18 foot island platform. However, the Clinton Street station—located at a point where the tracks are at different levels—requires special treatment. Stairways from the street as shown on Sheet 12 will provide access to the mezzanine about 18 feet below sidewalk grade. The eastbound platform level will be served by two escalators providing for both up and down movement of passengers and two additional escalators will be provided between the eastbound platform level and the westbound platform level as indicated on the plans. Thus, the platform serving the westbound or lower track, while approximately 85 feet below sidewalk grade involves use of stairways for only 18 feet of this distance—the remainder of the climb being accomplished by the use of escalators. This unusual but not impractical depth is necessitated by the proximity of Clinton Street to the flexing of tracks at Canal Street just west of the Chicago River, under which the subway must pass.

The construction of a subway-elevated incline on Lake Street to connect with the elevated structure near Racine Avenue on a gradient of 3 per cent will require the closing of Carpenter, Aberdeen and May Streets to through traffic. The subway portal is planned in the center of Lake Street and the improvement should include the acquisition of additional right-of-way on both the north and south sides of Lake Street so as to provide an over-all width of 120 feet between Racine Avenue and Sangamon Street. In this way, roadways of ample width will be provided on each side of the portal and the subway-elevated incline, affording adequate access to establishments located both on Lake Street and intersecting streets. The only inconvenience which might result, therefore, would be to through traffic on Carpenter, Aberdeen and May Streets originating south of Lake Street with destinations north of Lake Street and vice-versa.

Recent counts (December, 1938) made by the Street Traffic Bureau of the City of Chicago with W.P.A. personnel show a small total volume of normal week-day traffic on these streets, as follows:

<u>Street</u>	<u>Total Vehicles</u> <u>7 A. M. to 11 P. M.</u>
Carpenter	984
Aberdeen	646
May	428

The estimated cost of the Lake Street subway extension as shown in detail in Appendix II is \$4,400,000. This includes an allowance for private property proposed to be acquired on the north and south side of Lake Street between Racine Avenue and Sangamon Street and also for an easement under private property on the north side of Lake Street between Canal Street and Desplaines Street.

STREET CAR SUBWAYS

The completion of the initial system of subways together with the proposed extensions and connections on Congress Street and Lake Street will benefit street traffic only to the extent that it will pave the way for the removal of part of the elevated loop structure. There will still remain the congestion due to mixed street car and vehicular traffic across the bridges and on the east and west streets, aggravated by the turning movements of street cars in looping on Dearborn Street at the easterly end of their routes.

For these reasons as well as to expedite the movement of street cars and to shorten the time of travel of both street cars and vehicular traffic through the central business area, the city's engineers have been unanimous in their recommendations for the construction of two east and west street car subways extending from Clinton Street to Michigan Avenue. These subways, in reality additional underground streets, are also required to provide the west side with access to the eastern portion of the central business district and to the Lake Front. The subways now under construction do not afford this delivery for the west side.

Upon the completion of the proposed Washington and Jackson Street subways, all of the street car traffic from the west, northwest and southwest sides entering the loop district on east and west streets between Lake and Harrison Streets as well as tracks will be removed from the surface of the streets in all of of the entire congested area east of the Chicago River. There will be a further benefit through the convenient transfer to rapid transit subways and in providing delivery for west side car riders to the area between Dearborn Street and Michigan Avenue. These subways will furnish direct connections with the Van Buren Street and Randolph Street suburban stations of the Illinois Central Railroad, as well as convenient access to the North Western Railway terminal and the Union Station.

The public benefit to be derived from these two subways is not confined to street car riders. Traffic counts indicate these entering and leaving volumes which will be afforded improved traffic facilities annually:

Street Car Passengers	60,000,000
Suburban Railroad Passengers	46,000,000
Motor Car Passengers	50,000,000
Total	156,000,000

The beneficial effect of the two east and west street car subways measured in terms of additional traffic lanes released for other travel east of Clinton Street using a conservative figure per mile of lane for street widening and bridge construction in this area may be estimated as follows:

4.5 miles of additional street lane at \$3,000,000	\$13,500,000
Increase in capacity on 7 west side bridges	5,500,000
Total	\$19,000,000

This may be compared with the combined cost of both of the proposed subways of \$11,700,000. It is therefore urged that such underground facilities be constructed on Washington and Jackson Streets at the earliest possible date.

Washington Street Subway

The Washington Street subway is the more northerly of these improvements. As planned, it will be a two-track subway and will utilize the existing Washington Street tunnel between Clinton Street and Franklin Street. The construction of the Dearborn Street and State Street subways at low level requires the construction of this subway at high level. The plan and profile of the improvement is shown on Sheet 6 and typical sections are on Sheet 9. Continuous side platforms are planned from Wells Street to Michigan Avenue with station facilities at each street intersection. A typical high level subway station plan is shown on Sheet 11. A single track terminal loop is planned in Grant Park with a terminal station on the east side of Michigan Avenue, to provide direct connections to the Randolph Street suburban station of the Illinois Central Railroad.

The original plans for the Washington Street tunnel made specific provision for a connection to a future subway to the east, through the construction of the tunnel invert on a gradient connecting to subway grade at the west line of Franklin Street. This permanent lower structure is roofed over to provide the floor support for the existing street car tracks which now reach street grade at Franklin Street. It is now planned to utilize the permanent lower structure in the section between Franklin Street and a point near the river. This will permit the filling and paving of the opening in Washington Street west of Franklin Street. The estimated cost of this improvement is \$5,400,000.

Jackson Street Subway

The Jackson Street subway will be a two-track subway extending from Clinton Street to Grant Park. The existing Van Buren Street tunnel is proposed to be utilized as a part of this subway between Clinton Street and Market Street (see Sheet 7). However, it will be necessary to reconstruct a section east of the tunnel at Market Street in order to avoid interference with the large intercepting sewer of the Sanitary District of Chicago in Franklin Street. The general pattern of the development of this project is similar to that of the proposed Washington Street subway. The section on Jackson Street between Wells and Franklin Streets is designed with a gradient which will permit its subsequent extension to the west as a rapid transit subway. The estimated cost of the Jackson Street subway is \$6,300,000.

Connecting passageways extending from the platform on either side of both the Jackson and Washington Street subways are planned extending to a connection with the mezzanine stations to be constructed one-half block to the north and south respectively, on the subways on both State Street and Dearborn Street. This will facilitate the transfer of passengers between high level street car subways and low level rapid transit subways.

FUTURE SUBWAY EXTENSIONS—THIRD STAGE

This group of subway extensions comprises improvements, the need for which is evident now but is not as urgent as for the four extensions described above, scheduled for the second stage development in the comprehensive system of subways.

Wells Street Subway—Route No. 5

This two-track subway will be the third north and south subway route through the central business district and will provide downtown terminal connections for two tracks of the four-track Northwestern elevated railroad and for the two tracks of a proposed Ashland-Archer subway. The general plan of this subway is shown on Sheets 2 and 3. It will connect with the existing four-track Northwestern elevated structure north of Chicago Avenue and extend south along Wells Street and Franklin Street* to Archer Avenue, thence southwest in Archer Avenue to Ashland Avenue and south in Ashland Avenue to a terminal at 79th Street.

Stations are planned as follows:

Along Wells Street:

- at Chicago Avenue.
- at Grand Avenue.
- between Lake Street and Wacker Drive.
- between Washington Street and Van Buren Street.
- at Congress Street and Wells Street.
- and at Roosevelt Road:

* Proposed extension along a line about 150 feet east of the east dock line of the Chicago River as provided by the River Straightening Ordinance.

Along Archer Avenue:

- at Cermak Road and at Halsted Street.

Along Ashland Avenue:

- at 31st Street.
- at 35th Street.
- at Pershing Road.
- at 43rd Street.
- at 47th Street.
- at 51st Street.
- at Garfield Boulevard.
- at 59th Street.
- at 63rd Street.
- at 69th Street.
- at 74th Street, and
- at 79th Street.

The Wells Street Subway is planned at low level through the loop district so as to permit the construction of high level east and west subways in the area between Randolph Street and Van Buren Street, but will reach high level at Congress Street so as to pass over the Congress Street extension of the Dearborn Street Subway—Route No. 2.

This subway is proposed to supply a long felt need for expansion of rapid transit service. When completed, rapid transit trains can be through-routed from a terminal at 79th Street and Ashland Avenue to the several terminals on the north side—not only making rapid transit service directly available to many thousands of riders on the southwest side, but also having an important benefit in balancing the heavy north side rapid transit traffic.

The need for a rapid transit route along Ashland Avenue has been recognized since 1916. Numerous focal points of importance including the Stock Yards and the central manufacturing district would be given direct rapid transit service to the downtown business district. In addition, when supplemented by the subway extensions north of Archer Avenue proposed in the fourth stage of development of the system, this route would provide an adequate mid-city rapid transit service extending north and south about two miles west of the loop district.

An idea may be gained of the improvement in transit service which would result from this project from the fact that the present travel time from 79th Street and Ashland Avenue to the loop district (46 minutes) would be reduced to 25 minutes.

The completion of the Dearborn Street and Wells Street subways as herein proposed will permit the long desired removal of the elevated union loop structure. This project also includes a subway connection to the State Street subway extending from a two-way connection with the Wells Street subway east along 14th Street to State Street and north in State Street to a connection with Route No. 1 just south of the Roosevelt Road station. This connection will permit routing South Ashland Avenue trains to the north side through either the Wells Street or the State Street subways. A diamond crossover is planned in the 14th Street connection to allow the operators to turn back units to the north side terminals on either Route No. 1 or Route No. 5.

Milwaukee Avenue Extension

The lack of adequate rapid transit service in the important section of the city to the north and west of the existing Logan Square terminal has long been evident. To provide the necessary improvement, it is proposed to construct a two-track subway, extending from a connection with the Logan Square elevated structure at Logan Square northwest along Milwaukee Avenue to a terminal near Foster Avenue. The improvement would include the development of a suitable underground terminal in Logan Square in lieu of the existing elevated railroad terminal as described in detail in the 1937 report on "A Comprehensive Local Transportation Plan for the City of Chicago" (see Figure 6).

Stations are tentatively planned along Milwaukee Avenue at or near

Pulaski Road,
Addison Street,
Irving Park Road and Cicero Avenue,
Montrose Avenue,
Lawrence Avenue, and
Foster Avenue.

The average station spacing—about $\frac{3}{4}$ mile—will permit high over-all schedule speeds and comparatively low construction costs. The great benefit to residents of the northwest side which would result from this project is evident from the improved running time. It is estimated that the operation of modern rapid transit trains on this direct route would reduce travel time from Foster and Milwaukee Avenues to the loop district from the 45 minutes now scheduled on the combined street car-elevated route to approximately 22 minutes. This diagonal route, intersecting all of the east and west and the north and south local transit routes would effect an enormous improvement in transit service to the entire northwest section of the city. These benefits will be further amplified when branches along Belmont and North Avenues extending west from Milwaukee Avenue are completed under the fourth stage program hereinafter suggested.

Douglas Park Connection

This connection is planned as a two-track low level subway extending from a connection to the proposed Congress Street subway in the vicinity of Desplaines Street, extending thence southwest across private property and along Blue Island Avenue to Cullerton Street and thence west along private property to a connection with the existing Douglas Park elevated railroad structure near Wood Street. Stations are planned along Blue Island Avenue at Halsted Street, at Roosevelt Road and at 18th Street.

This subway is planned to provide a more direct route between the Douglas Park branch and the central business district shortening the existing route by approximately 0.7 mile. This more direct route, the reduction in number of station stops and the use of new, modern high speed equipment will save patrons of the Douglas Park elevated approximately 15 minutes on their daily round trip. The building of this subway will also permit the use of the existing elevated structure parallel to Paulina Street for crosstown rapid transit train service. Further, it will provide for through routing trains from Douglas Park to the northwest side, thereby tending to balance the heavy northwest side rapid transit traffic. Another benefit would result through the provision of direct rapid transit service in a populous section of the city not now so served—along Blue Island Avenue between Halsted Street and Ashland Avenue.

FUTURE SUBWAY EXTENSIONS—FOURTH STAGE

The third group of subway extensions proposed for future construction consists largely of the extensions to provide rapid transit service in portions of the urban area where substantial increases in population are expected to occur in the next decade or more and where development should be encouraged.

South Park Avenue Extension

This subway is planned as an extension of the Jackson Park elevated railroad route into new rapid transit territory. It would consist of a two-track subway and incline connecting to the existing elevated structure just west of South Park

Avenue and extending southerly through private property and along South Park Avenue to a terminal at 79th Street.

This subway extension is planned to provide rapid transit service in that section of the south side between and not served by the Rock Island or the Illinois Central Railroads. On its completion most of the south side north of 79th Street will be within one mile of either elevated-subway routes or suburban railroad service.

While future development south of 79th Street may be such as to ultimately warrant the extensions of the South Park Avenue and Ashland Avenue subways, the present indications are that this far south side area will continue to develop as more or less self-contained residential, industrial and commercial center with insufficient density of traffic to warrant through rapid transit service to the central business district, at least for many years to come.

Archer-Cicero Avenue Extension

This extension is a logical extension of the Wells-Archer-Ashland subway proposed for earlier construction. The most reliable available forecasts of population growth in the city indicate substantial increases in population in the areas which would be served by this extension (see Figure 1). There is probably no section of Chicago comparable in size and location now so hampered by lack of adequate rapid transit. The construction of this subway would not only provide for the needs of the residents of this growing district but would also vastly improve transit facilities to the Municipal Airport and the several industrial developments in the vicinity of the route.

North Avenue Extension

This subway consists of an extension of the Humboldt Park branch of the elevated railroad system to the west so as to serve this rapidly growing section of the northwest side. It is planned as a two-track subway with an incline connecting to the existing terminal of the Humboldt Park elevated near Lawndale Avenue—extending west from said connection through private property and along North Avenue to Central Avenue. While this is shown as a subway extension there is a possibility as suggested in the 1937 report on "A Comprehensive Local Transportation Plan for the City of Chicago" of constructing local rapid transit railroad tracks along the right-of-way of the Chicago, Milwaukee, St. Paul and Pacific Railroad.

Belmont Avenue Extension

One of the most vigorous districts in Chicago has developed during recent years in the section of the northwest side west of Milwaukee Avenue. A subway branching west from the Milwaukee Avenue subway along Belmont Avenue would provide much needed rapid transit service in this district and would, with the other subway extensions proposed, supplemented by existing elevated and railroad suburban service, bring rapid transit within one mile of most of the northwest side of Chicago.

This extension would consist of a two-track subway connecting to the proposed Milwaukee Avenue extension near Belmont Avenue and extending west along Belmont Avenue to Oak Park Avenue.

Milwaukee Avenue Subway—Express Track

With the construction of the extensions as proposed for Milwaukee Avenue and Belmont Avenue, it will be desirable to provide for express service during the rush hours on the Milwaukee Avenue and Belmont Avenue routes. This may be accomplished by the construction of a single track tunnel along Milwaukee Avenue connecting to the Milwaukee Avenue subway near the Ashland-Division station on the southeast and near the Logan Square station on the northwest.

This will permit non-stop express service through a section more than two miles in length. The character of the operation would be similar to the present service on the South Side elevated division where express service is operated downtown in the morning rush hour and outbound during the evening rush hour over the third track between the Indiana Avenue and Roosevelt Road stations.

Crosstown Subways

The decentralization of the activities formerly carried on and concentrated in the loop district which have been spreading beyond the Chicago River, both to the north and to the west, will undoubtedly be accelerated through the construction of the subway extensions recommended herein for construction during the second and third stages of development. So far as it may now be estimated, future accretions in the volume of commercial and industrial activities carried on in the central business district will take the form of continued distribution to a greater area which may conceivably extend to North Avenue, Ashland Avenue and Cermak Road.

The outstanding flaw in the existing pattern of Chicago's rapid transit system is the complete absence of facilities for north and south crosstown traffic. This fundamental weakness was disclosed by the studies of the Traction and Subway Commission of 1916, where a comprehensive origin and destination count of all passengers utilizing the facilities of the elevated system developed the fact that some 14,000 persons daily would utilize a crosstown route extending north and south along an axis approximately two miles west of the loop. In that report the commissioners recommended the construction of elevated extensions; one, extending north from the Logan Square elevated structure north of Division Street, to a connection with the Ravenswood elevated structure near Roscoe Street; and the second, an extension south along the general line of Ashland Avenue from a connection with the Douglas Park elevated structure near Cullerton Street to 69th Street.

In a report of the Subway Advisory Commission appointed by a sub-committee on subways of the Local Transportation Committee of the Chicago City Council, August, 1926, composed of representatives of various downtown business interests and drafted by Mr. Gordon Strong, the necessity for a north and south crosstown rapid transit was covered as follows:

"All of the north and south transportation which necessarily, or most advantageously, comes to the downtown district, should be routed to the downtown district. But all of the north and south transportation which may equally well be routed elsewhere, not only may be routed but should be routed elsewhere. It should be routed elsewhere for the avoidance of unnecessary diversion and of delay, by reason of passing through the downtown district.

"Now, north and south transportation routed outside of the downtown district, can not be routed to the east of that district (by reason of the Lake). It must be routed to the west of that district. And this fact forms the basis of the important proposed Ashland Avenue elevated extension.

"This Ashland Avenue elevated extension is supported by the engineering studies of the past. Reference may be had to:

"The report of the Chicago Traction and Subway Commission of 1916, Plate I.

"The report of Major R. F. Kelker, Jr., of 1923, Plate I.

"The report of Honorable Francis X. Busch, upon the Transportation Ordinance of 1925 (Exhibit B).

"Our opinion as to the propriety of the construction of the Ashland Avenue elevated extension rests not only upon the principles above noted; not only upon the engineering reports above referred to; but also upon the expert advices which we have received in this connection.

"We believe that the construction of the Ashland Avenue elevated extension will materially relieve the rapid facilities of the downtown district. That it will provide citizens of the Northwest and of the Southwest Sides with a means of direct and rapid communication, to which they have long been entitled. And that it will tend to the proper development of those sections of Chicago through which it will pass. We know of no new rapid transit facility more needed or in any way more commendable than the Ashland Avenue elevated extension."

The fundamentals of the recommendations made by the commissioners in 1916 and by the Strong Commission of 1926 are just as sound today as when first written. Since that date there has been a steady development of the central business district to the west. However, the present trend in rapid transit construction is away from the construction of additional railroad structures except where subway construction is entirely impracticable. With the final removal of the entire loop structure—permitted by the construction of the subway extensions recommended in the third stage—and with improved transit facilities in the areas immediately north and west of the river, these close-in districts will grow and develop.

For these reasons it is recommended that a crosstown rapid transit route be planned as a future subway extension as follows:

- (1) A two-track subway extending, from a connection with the existing elevated structure south of Division Street and just west of Paulina Street, northerly along a route between Ashland and Damen Avenues to a connection with the Ravenswood elevated structure near Roscoe Street; and
- (2) A two track subway extending, from a connection with the Douglas Park elevated structure north of Cullerton Street, south along the general line of Ashland Avenue to a connection with the Ashland Avenue subway recommended for construction in the third stage.

When completed this rapid transit route will provide facilities for crosstown movements from the Ravenswood branch (Lawrence Avenue) on the north and from the Milwaukee Avenue route (Foster Avenue on the northwest) to 79th Street on the south, and provide direct delivery to such important focal points as the Union Stock Yards, the central manufacturing district, the Chicago Stadium and the numerous commercial and industrial areas located in this great district.

Michigan Avenue Subway Connection

This additional subway connection may be desirable in the future to connect the east terminals of the Washington Street and Jackson Street subways. Such a connection would provide a greater flexibility of service and also improve the distribution of traffic through the construction of stations along Michigan Avenue between Washington Street and Jackson Street. Thus passengers from either the Washington Street or the Jackson Street subway could be delivered to any point along Michigan Avenue between Van Buren and Randolph Streets.

THE RELATION OF SUBWAYS TO THE MODERNIZATION OF CHICAGO'S LOCAL TRANSPORTATION

The additional subways and subway extensions recommended and suggested herein have been planned to fit in the now accepted pattern of development of the entire local transportation system. Ever since the investigation and report made by the Traction and Subway Commission in 1916, competent students of the problem have recognized the impossibility of financing a system of rapid transit routes which would provide direct service to Chicago's entire population. However, it has been the aim of transportation planners to provide sufficient rapid transit facilities to furnish adequate routes for long distance riders between various sections of the city which, when coordinated with local railroad service and with distributor and feeder surface lines, would make rapid transit available, either directly or indirectly, to all.

The practicability of this scheme for coordinated transit in Chicago has been demonstrated through the inter-company transfer plan, which has been in operation for about four years. The present limited transfer arrangement provides for the interchange of passengers between the rapid transit lines and the local distributor and feeder routes at 75 stations of the rapid transit system within the city. As compared with estimates of 30,000 daily inter-company transfer passengers made prior to the experiment, use of the privilege has steadily increased to the point where it is now actually about 120,000 on a typical week-day. Current analyses of the origin and destination of inter-company transfer passengers shows an average total length of ride of between 9 and 10 miles, of which more than 8 miles is on the rapid transit system. Inter-company transfer traffic now constitutes more than one-fourth of the total passengers carried on the rapid transit system.

This remarkable result has been achieved with no improvement in the rapid transit service whatsoever. The equipment is of the same obsolete type that has been operated for many years and there has been no recent improvement in sched-

uled running times. Elevated trains still experience the same delays in operating through the congested two-track loop during rush hours, and while subways are in construction and purchase of new equipment is planned, none of these improvements have had any influence in inducing use of the rapid transit system by long distance riders.

Likewise a few experimental transfer arrangements between local distributor routes and suburban railroad service has proved the practicability of expanding this coordination of all available rapid transit facilities.

With the completion of the subways now under construction and the building of subway extensions as recommended herein, coupled with the operation of new high speed and convenient rapid transit train equipment and the re-location and modernization of stations on the rapid transit system so as to facilitate transfer of passengers to local distributor lines, there will be a gradual transfer of traffic from the local street car and bus lines, operating at street grade and subject to all of the interferences inherent in such operation, to the off-grade elevated-subway rapid transit system. The pattern of the rapid transit system, extended as planned, will greatly improve the articulation of the network of local distributor lines throughout the city, with the result that only a limited portion of the city's population will be required to ride more than 2 miles before reaching a rapid transit route.

Suburban Railroads

The 1937 report on "A Comprehensive Local Transportation Plan" dealt in some detail with the possible use of existing suburban railroad facilities. As discussed in that report, there is but limited opportunity for the use of existing radial steam railroad rights-of-way for the installation of new local rapid transit tracks. However, the coordination of suburban railroad service with the unified service provided by the local bus and street car routes, as described in that report, is practicable, and will serve to extend the rapid transit trunk line network to practically all portions of the urban area. A study of the distribution of the 1930 population of Chicago, the location and comparative size of the various commercial and industrial areas within the corporate limits of Chicago was made by the staff of the Committee on Local Transportation in 1937 based on best data then available. This information is plotted on Figure 5 which also shows the comprehensive rapid transit system herein recommended as supplemented by the several suburban railroad services proposed to be coordinated in the local transit plan. It will be noted that this net work provides a fairly adequate coverage of all of the city's area. Plans for modernization and unification of the local transit systems will undoubtedly include a number of express bus routes to supplement the off-grade rapid transit facilities, and thereby insure convenient access for all sections of the city to the rapid transit system.

The reduction in travel time between points in various sections of the city, which will result from the construction of all of the routes included in this plan and their operation coordinated with the modernized local lines, is shown in the following tabulation:

TRAVEL TIME BETWEEN VARIOUS FOCAL POINTS

Using proposed comprehensive system of subways coordinated with modernized system of surface feeder and distributor routes.

FOCAL POINT—LOOP DISTRICT	TRAVEL TIME—IN MINUTES		
	<i>Present</i>	<i>Proposed</i>	<i>Savings</i>
Ravenswood Branch—			
Kimball and Lawrence	28	25	3
Milwaukee Avenue at Foster	45	22	23
Belmont Avenue at Oak Park	49	24	25
North Avenue at Central	38	20	18
Garfield Park Branch at Austin Avenue	24	20	4
Cicero Avenue at 63rd Street	53	25	28
Ashland Avenue at 79th Street	46	25	21
South Park Avenue at 79th Street	36	23	13
FOCAL POINT—STOCK YARDS			
Central and Lake	44	30	14
Cicero and North	48	33	15
Central and Belmont	64	35	29
Lawrence and Milwaukee	70	36	34
Kedzie and Milwaukee	49	27	22
Lawrence and Western	49	35	14
92nd and Commercial	48	42	6
79th and South Park	39	21	18
FOCAL POINT—SEARS ROEBUCK CO. (Arthington and Homan)			
Montrose and Western	40	33	7
55th and Ashland	47	31	16
Central and Chicago	25	20	5
FOCAL POINT—MONTGOMERY WARD CO. (Chicago and Larrabee)			
63rd and Ashland	55	32	23
Central and Belmont	43	25	18
Lawrence and Elston	39	29	10
FOCAL POINT—WESTERN ELECTRIC (Cermak and Cicero)			
Lawrence and Western	55	39	16
63rd and Ashland	48	32	16
Chicago and Western	35	24	11

Future Rapid Transit Operations

An estimate of the probable traffic on the several routes of the elevated and subway system has been made for the purpose of determining the adequacy of the downtown terminals as planned. For this purpose the distribution of population as of 1950 has been utilized (see Figure 1). Estimates of traffic have been made, after consideration both of the density of the population and the characteristics of the several sections of the city to be served. After determining the probable total traffic, an estimate of the future maximum rush hour traffic was made, based

on the present relationship between maximum half hour counts at the points of maximum traffic on the existing elevated system to total annual traffic. The results of this study are shown in the following tabulation, which shows the approximate number of passengers entering the central district during the maximum 30 minutes of the morning rush hour, based on the estimated distribution of population in 1950 and assuming the completion of the comprehensive subway system:

INBOUND TRAFFIC—MAXIMUM 30-MINUTE PERIOD		
<u>Originating on Rapid Transit Division</u>	<u>Total Passengers at Maximum Points</u>	<u>Delivered to Subway Route</u>
South Side (present elevated system)	8,100	
South Park Avenue subway extension	2,500	
	10,600	State Street
Archer-Ashland subway	3,600	
Archer-Cicero subway	3,600	
	7,200	Wells Street and Crosstown Route
Douglas Park elevated	3,300	
Garfield Park elevated	5,700	
	9,000	Dearborn Street
Lake Street elevated		
Logan Square and Humboldt Park (present elevated system)	6,300	
Milwaukee and Belmont subway extensions	4,700	
North Avenue subway extension	2,000	
	13,000	Dearborn Street and Crosstown Route
North Side (present elevated system)	25,000	State Street and Wells Street
Crosstown subway extension	2,000	Crosstown Route
Total—All Rapid Routes	74,800	

However, this indicates an unbalanced distribution of loading as between the lines entering from the north and northwest sides and those entering from the south and southwest sides of the city. The system as planned provides the utmost of flexibility for future operation. Traffic from the north side and from the Ashland-Archer subways can be routed through either the State Street or the Wells Street subways. Facilities are planned for turning back the unbalanced traffic originating on the north side. Traffic from the northwest side can be routed to a downtown terminal—the Dearborn Street subway—or south along the Ashland Avenue crosstown route. From data now available it may be estimated that approximately 70 per cent of the traffic originating on the northwest side may be routed to the central business district through the Dearborn Street subway. This amounts to approximately 9,000 passengers in the maximum 30-minute period which, with the estimated 8,000 passengers from the Lake Street route, produces a total of

17,000 passengers in the maximum 30-minute period. This traffic will be balanced by a total of 9,000 from the Garfield Park and Douglas Park routes entering the Dearborn Street subway along the proposed Congress Street extension. The excess traffic will be turned back at the proposed loop on Congress Street west of Wells Street.

Of the total 25,000 passengers in the maximum 30-minute period originating on the north side routes, it may be assumed that approximately 60 per cent, or 15,000, would be routed through the State Street subway. Thus it is seen that the terminal subways now planned are adequate to carry the traffic originating on all of the branches of the comprehensive rapid transit system.

This traffic on the Dearborn Street subway between Lake Street and Milwaukee Avenue and the proposed Congress Street loop approaches the track capacity as conservatively estimated in the 1937 report on "A Comprehensive Transportation Plan for the City of Chicago." In the event of an unanticipated increase in traffic from the northwest side, it may be necessary to construct another terminal subway to supplement the Dearborn Street subway, Route No. 2. This subway might be constructed in one of the north and south streets west of the Chicago River, or in an east and west street north of the Chicago River; connecting to the Milwaukee Avenue subway at a point northwest of the intersection of Milwaukee Avenue and Lake Street. The determination of the exact route of such supplemental terminal subway can best be made as, if and when required and in accordance with the developments in and near the central district between now and such future date. However, the necessity for such a subway is so remote that it is not shown on these plans.

PART II

WIDENING AND IMPROVEMENT OF CONGRESS STREET

The grant agreement with the Federal Government also requires the preparation of plans for the widening of E. and W. Congress Street from S. Michigan Avenue westward. The surveys and studies necessarily preliminary to drafting plans were carried on with a view to the development of a plan for a major thoroughfare along the general line of but not strictly limited to the present location of Congress Street. Consideration of the general superhighway pattern was necessary in planning this improvement.

The plans for the opening and widening of Congress Street are shown on Sheets 13 to 44, inclusive. These plans have been prepared in some detail for that section of the project in the "subway zone" east of Throop Street while the development of this thoroughfare between Throop Street and the west city limits has been prepared in less detail merely as a suggestion, inasmuch as it is not directly related to the subway plan.

Previous Proposals for the Congress Street Improvement

The more important proposals for the development of a Congress Street thoroughfare which have been suggested in the past were considered in the development of the present plans. These included:

- (1) The conception of Congress Street as the central axis of the city—with a width of 200 to 300 feet east of Ashland Avenue in the "Plan of Chicago" by D. H. Burnham and E. H. Bennett in 1908;
- (2) A thoroughfare 146 feet in width at grade—proposed by Bennett, Parsons and Frost and also Mr. I. F. Stern;
- (3) An elevated highway 120 feet in width—a study by the engineering staff of the Chicago Plan Commission;
- (4) A thoroughfare 200 feet or more in width with separation of grades between express roadways and important intersecting thoroughfares—prepared by the Division of Highways of the State of Illinois, in 1935; and
- (5) A modification of the above state plan providing for elevation (rather than depression) of express roadways over the principal intersecting thoroughfares as contained in the report of the Committee on West Side Superhighways to the Honorable Oscar E. Hewitt, 1938.

The major objective in all of these plans was to provide a thoroughfare of large capacity for traffic from and through the outlying sections of the west side of Chicago and from the suburban area to the central business district. All plans contemplated the provision of adequate means of ingress and egress to the thoroughfare at convenient but not too frequent points between the central business district and Columbus Park as well as suitable connections at frequent and convenient locations in the loop district and just west of the river so as to provide for delivery of vehicles not only to the central business district but also to the near

west side commercial and industrial areas. East of Canal Street, Congress Street would constitute the south unit of a system of inner distributor streets and as such would function in a good deal the same way as the present improvement on the upper level of Wacker Drive. In the 1908 Plan of Chicago, Congress Street was to be a wide plaza extending from Grant Park to a Civic Center west of Halsted Street.

All of these proposals have been studied in detail as a preliminary to the preparation of the plans submitted herewith. The first two plans—prepared at an earlier date—were in line with best thought in planning major thoroughfares before the present day concentrations of vehicular traffic which have made apparent the necessity for the complete segregation of through traffic from local vehicular and pedestrian traffic.

The third plan—for an elevated highway—failed to include provision for free ways on each side of grade separated express roadways through residential areas. Experience has proven—in innumerable cases—that damage will accrue to residential and, in some cases to commercial properties in areas traversed by elevated structures. This damage does not always occur immediately, but is sometimes brought about over a considerable period, during which property values decrease and entire districts deteriorate. Out of such experiences, there has developed the now generally recognized principle—that the cost of providing reasonably liberal free ways (whether the express roadways be elevated or depressed) segregating large masses of motor vehicles, with their exhaust gases and noises, from surrounding property will not only cost no more in the long run, but may actually be a benefit to the area traversed.

Proposals 4 and 5 made in 1935 and 1938 respectively made provisions for free ways and, in general, incorporated most of the features now recognized as essential to the proper building of express thoroughfares in a large metropolitan center. However, both plans have been criticized due to the fact that the east and west express roadways were subject to interference of cross traffic—both vehicular and pedestrian—at a number of points throughout the high speed sections between Canal Street and the west city limits.

More recent trends in superhighway planning are contained in a report published in April, 1939 by Mr. Thomas H. MacDonald, Chief of the Public Roads Administration, Federal Works Agency. In this report, which was transmitted by the President to Congress for its consideration, he advocated as the greatest immediate need in the development of the nation's highway systems the construction of through traffic facilities in large metropolitan cities. He also is of the firm conviction that these express metropolitan highways should be so planned as to contribute not only a structure adequate for the uninterrupted flow of through automotive traffic, but also designed so as to contribute to the restoration of the depreciated areas through which they will generally be located, rather than to aggravate the serious deterioration which such districts have already suffered. He recommended in some detail the planning of these improvements as depressed

thoroughfares in broad rights-of-way wherever feasible and that the Federal Government extend substantial financial aid to local governments in accomplishing this objective. The following excerpts from that report are of interest:

"In the larger cities generally only a major operation will suffice—nothing less than the creation of a depressed or an elevated artery (the former usually to be preferred) that will convey the massed movement pressing into, and through, the heart of the city, under or over the local cross streets without interruption by their conflicting traffic. Such facilities are not required in any city for the service of through highway traffic alone. They are not required solely for the service of the traffic entering the city from typically rural highways. There usually is added to these streams in the outer reaches of the city or its immediate suburbs a heavy movement of purely city traffic that mounts to high peaks in the morning and evening rush hours."

Mr. MacDonald discusses the situation at Baltimore as being typical of that in all large cities, as follows:

"It is apparent that the whole interior of the city is ripe for the major change that it must undergo to afford the necessary relief to pressures generated by the effort to force the stream of 20th-century traffic through arteries of the early 19th century. The map shows where properties are dying. In places, new and important developments are beginning to occur—developments of great possible significance in relation to the future plan of the city and particularly to the new major arteries that should supply the skeletal structure for that plan.

"The general appearance and design of a depressed artery of the type suggested is shown in plate 54. As illustrated, the depressed and divided arterial lanes would be bordered on each side by one-way surface streets for local service. At intervals, important cross streets would be bridged over the depressed way.

"The depressed highways, especially, would necessitate acquisition of wide rights-of-way, and it is because property along several of the suggested lines has already dropped close to its lowest level, and land can therefore be obtained at approximately minimum cost, that the time is now ripe for the undertaking of such improvements."

Specifications for a West Side Superhighway

Since the preparation of any of the earlier plans, there has been a notable advance in the design and construction of grade separated thoroughfares in and near New York City and elsewhere so that many of the problems in connection with this type of development can be solved on a substantial background of actual experience. Based on recent outstanding developments of grade separated thoroughfares—general specifications for the sections of the proposed west side superhighway outside of the terminal area—may be outlined, as follows:

1. Complete segregation of local and through traffic, limiting the use of superhighways to fast moving passenger vehicles including express but not local buses.
2. Elimination of left turn or other crossing movements.
3. Entrance and exit ramps generally two lanes in width connecting to the outer lanes of express roadways.

4. Adequate widening of express roadways at approach sections near ramp entrances and exits so as to provide suitable space for acceleration and deceleration.
5. Segregation of opposing streams of traffic by a center strip or parkway.
6. Roadway widths to provide lanes of 12 feet—adequate for fast moving vehicles.
7. Complete elimination of pedestrians from the express roadway zone.
8. Free ways in residential or quasi-residential districts—adequately landscaped—providing suitable space between express roadways and abutting property—protecting the nearby residents from exhaust fumes and eliminating the noise nuisance.
9. Sidewalks and parallel roadways adequate to serve for property abutting the superhighway—also cross-roads and sidewalks at convenient intervals, and
10. Effective landscaping of the entire right-of-way so as to benefit rather than damage the area penetrated by the thoroughfare.

The plans submitted herewith for a west side superhighway have been developed on the above specifications with a view to providing adequate facilities for long distance traffic and for the complete segregation of through from local traffic; and further to providing a facility which, when supplemented by neighborhood parks, playgrounds and housing developments will add to rather than detract from the neighborhoods immediately adjacent. The improvement as planned would provide physical facilities for delivery of large volumes of traffic to the medical center, the near west side and central business districts and when supplemented by suitable traffic control will permit the concentration of large volumes of traffic on this single thoroughfare with a minimum of interference to local traffic on streets in the terminal areas. In this connection it should be noted that present plans are required to extend easterly from Wells Street to Michigan Avenue adding to the extent and cost of improvements formerly proposed, but greatly improving terminal connections in and near the central business district.

THE CONGRESS STREET IMPROVEMENT IN THE SUBWAY ZONE

Michigan Avenue to State Street

Between State Street and Michigan Avenue, Congress Street is 66 feet in width. The widening of this section would involve heavy damages to a number of important buildings, notably the Sears-Roebuck store, the Auditorium Theatre, the Auditorium Hotel and the Congress Hotel. Preliminary studies indicate that the cost of widening in the two blocks between State Street and Michigan Avenue to a width of 120 feet would cost in excess of \$2,000,000. A number of the more important buildings are of such age, that their early removal and replacement by modern structures seems probable. In view of the heavy cost of such widening and of the fact that the volume of traffic in this section will be less than at any point farther west on the thoroughfare, it is suggested that the present improvement between State Street and Michigan Avenue be limited to the widening of the existing pavement to a width of 50 feet. While the proposed 50 foot roadway will provide

for two lanes of traffic in each direction, which will be adequate in our judgment for some time to come, there is no question of the ultimate desirability of completing the 120 foot thoroughfare from State Street to Michigan Avenue, as suggested on Sheet 14.

In the park east of Michigan Avenue, the plaza planned years ago has been constructed. If traffic from Congress Street on the west is to be given direct access to Columbus Drive, it probably will be necessary for the Chicago Park District to rearrange the plaza on the east side of Michigan Avenue so as to provide roadways extending directly east and west through the center of the existing stairway. It is our opinion that plans can be perfected for such rearrangement which will preserve the effective treatment of the existing plaza. However, the volume of traffic in the immediate future on Congress Street at Michigan Avenue is estimated (see Appendix 1) to be so small as to constitute no serious problem for the present even if no direct connection is provided to the north and south drives in Grant Park.

State Street to Wells Street

Between State Street and Wells Street, the Congress Street thoroughfare would function largely as a distributor street and as such must necessarily be at or near the present street grade. Consideration was given to the development of off-grade facilities through the construction of a double deck highway in this area somewhat similar to that on Wacker Drive; but the necessity for passing under the existing tracks of the LaSalle Street terminal station of the Rock Island and the New York Central Railroads; the short lengths of the blocks between Congress Street and Van Buren Street on the north and Harrison Street on the south, which present an almost impossible problem of ramp construction in the north and south streets; and finally, the desirability of providing for the free movement of traffic in this terminal zone lead to the adoption of the single level plan.

Some consideration was also given to a vehicular tunnel along Congress Street under the Chicago River. Such a tunnel would extend from a point west of Clinton Street to LaSalle Street. The building of such a structure would involve the permanent closing of both Clinton and Sherman Streets and would require the present street grade of Jefferson Street and LaSalle Street to be lowered substantially. Thus there would be no connection between the superhighway and the following streets:

Clinton Street
Canal Street
Market Street
Franklin Street
Wells Street
Sherman Street

This would result in concentrating the delivery of 1,215 passenger vehicles in the area between LaSalle Street and Michigan Avenue, as compared with the estimated figure of 800 involved in the present layout. In other words, of the traffic estimated to pass Jefferson Street on the present plan, approximately 34 per cent have destinations most conveniently reached by the above named streets and would be required to travel additional distances and to increase traffic concentrations in the areas either east or west of the tunnel portals.

The construction of such a vehicular tunnel would require radical changes in the construction of the Congress Street extension of the Dearborn Street subway as now planned. This rapid transit subway would have to be lowered and the cost would be increased enormously. For all of these reasons it is recommended that no further consideration be given to the construction of a vehicular tunnel in this area.

The opening of a thoroughfare with an over-all width of 120 feet is contemplated in the area from Wells Street to State Street as shown on Sheet 15. Estimates of probable Congress Street traffic in this area based on studies of present characteristics of east and west major traffic streams discussed in detail in Appendix 1, indicate total vehicles during the maximum 30-minute period as follows:

ESTIMATED TRAFFIC VOLUME ON CONGRESS STREET

<i>At the East Line of</i>	<i>Number of Vehicles</i>	<i>Percentage of Total at Maximum Point (Ashland Avenue)</i>
Wells Street	840	42
Clark Street	600	30
State Street	280	14

These east and west traffic volumes are such as can be handled conveniently by three through lanes in each direction at Wells Street, decreasing to two through lanes at Clark Street (see Figure 27). Vehicles in the terminal area east of Wells Street will of necessity move at comparatively low speeds, so that traffic lanes 11 feet in width will be adequate. Roadways 42 feet in width are planned between State and Wells Streets providing three inner lanes for moving traffic and one outer lane 9 feet in width. The additional outside lane will provide for vehicles making local service stops at the curb. East of LaSalle Street, the inside lane may be reserved for vehicles about to make a left turn.

Through the installation of one-way street traffic control on Sherman Street and LaSalle Street (see Figure 27) it will be possible to control traffic movements so as to eliminate any obstructive left turn movements at their intersections with Congress Street. Such recommended control would not only eliminate all obstructive left turn movements on the entire west side superhighway west of Clark Street but would also greatly improve the efficiency of the existing narrow roadways on Sherman and LaSalle Streets. Further, it would simplify the problem of traffic control at the intersection of those streets with Jackson Street. Movements of taxicabs and passenger automobiles to and from the LaSalle Street station would be expedited and greatly simplified through the provision of a separate local roadway just north of the proposed Congress Street opening which would permit vehicles to enter the LaSalle Street parking area and taxicab stand by southbound movements in Sherman Street and exit by northbound movements in LaSalle Street. Anyone familiar with the confusion and delay attendant on vehicular movements in the vicinity of this passenger terminal, particularly at the time of the arrival or departure of the numerous important trains, will appreciate the desirability of a more orderly system of traffic control.

Similarly, one-way street operation on Federal Street and Plymouth Court would improve their efficiency and also simplify the movements of traffic along the Congress Street thoroughfare between Clark Street and State Street. The chart showing proposed traffic control in the terminal area—Figure 27—assumes such traffic control. The spacing of Federal Street, Dearborn Street and Plymouth Court is so close as to fully warrant the adoption of one-way traffic regulations. The situation here may be compared with that in New York, where the distance between east and west streets on Manhattan Island is about equal to the total distance between Federal Street and Plymouth Court, and where one-way traffic control has been in successful operation for years.

It is also suggested that left turn movements for westbound traffic on Congress Street be eliminated at Dearborn Street. This should involve no hardship inasmuch as a number of alternate routes are available for vehicles with origins on Congress Street east of Dearborn Street and destinations south of Congress Street along Dearborn Street.

A center parkway 8 feet in width is proposed through the Wells Street-State Street section. This will accommodate the columns required for the support of the LaSalle Street station (see Sheet 22), will enhance safety for motorists through separation of opposing streams of traffic and for pedestrians through the provision of generous safety islands at the center of the proposed broad roadway. It will simplify the negotiation of left turns at Clark Street and intersections to the east and and further will provide an attractive appearance through simple landscaping treatment. The effectiveness of this type of thoroughfare has been thoroughly demonstrated along Park Avenue north of the Grand Central Terminal in New York City and elsewhere. The construction of a sidewalk 14 feet wide on each side of the thoroughfare would complete the 120 foot wide improvement. This width of sidewalk is ample to provide for any predictable development.

Wells Street to Canal Street

East of Canal Street use will be made of the existing roadways and sidewalks reserved for this purpose through the Post Office building. It is proposed to complete the center strip through this section so as to conform to the pattern of the express highway both east and west of the Post Office. Such a center strip will require the discontinuance of the present practice of making left turns into and out of the ramps and driveways extending from the south side of the Congress Street opening into the first and second levels of the Post Office. It would also be necessary to regulate the traffic on the driveway just east of the Post Office so as to conform to the general method of traffic control proposed for the entire thoroughfare. This may require the installation of traffic actuated control signals both at the ramps and at the driveway east of the building. The interference both of the movement of traffic along the Congress Street thoroughfare and to the local traffic will be but slight as demonstrated by recent counts of actual traffic to and from the Congress Street entrances and exit and along the east driveway of the Post Office. These counts are summarized as follows:

COUNTS OF TRAFFIC AT THE
CONGRESS STREET ENTRANCES TO THE POST OFFICE
Average of Five Week-Day Counts—7 A. M. to 11 P. M.

OCTOBER, 1938

<i>Movement</i>	<i>Roadway</i>	<i>Total Vehicles</i>
Southbound	West Ramp	541
Northbound	East Ramp	1,460
Southbound	Interior Roadway to Harrison Street	369
Southbound	Driveway just east of Post Office—	
	North of Congress Street	552
	South of Congress Street	418

Each of the express roadways through the building will have a width of 40 feet, thus permitting the full use of three lanes for moving traffic and an outer lane for local vehicles moving to and from the Post Office.

The roadways from the Post Office east to the river will conform to the width of the opening through the building on the west, gradually decreasing near the river by means of easy reversed curves so as to conform to the roadway widths of the proposed Congress Street bridge on the east (see Sheet 16). Under the terms of the Union Station Company ordinance of March 23, 1914, a short section of viaduct between the Post Office building and the bridge must be constructed and paid for by the Union Station Company and is therefore not included in the cost estimates.

The narrower width east of Canal Street—3 lanes in each direction for through traffic—is consistent with the prospective use of the express roadways. The analysis of existing traffic movements described in detail in Appendix 1 shows an estimated maximum half hour use of the thoroughfare east of Canal Street of 1,260 vehicles or 63 per cent of that at the point of maximum traffic at Ashland Avenue.

The tentative plans for the new Congress Street bridge provide for two roadways each 34 feet in width, a center strip 3 feet wide and 2 sidewalks each 12 feet in width (see Sheets 23, 24 and 25). Preliminary plans for the Congress Street bridge have been made by the Division of Bridges of the Department of Public Works. Three studies have been made showing (1) a vertical lift bridge (Sheet 23), (2) a fixed bridge (Sheet 24), and (3) a bascule bridge (Sheet 25). A memorandum from the Division of Bridges furnished through the courtesy of the Honorable Oscar E. Hewitt, Commissioner of Public Works, on June 2nd comments briefly on the three designs as follows:

"City Bridge Division drawings Nos. 15617 (Sheet 25), 15618 (Sheet 23) and 15619 (Sheet 24) show studies of three different types of bridges for the proposed opening of Congress Street across the South Branch of the Chicago River. For a movable bridge, this proposed crossing involves peculiar difficulties which have been the subject of extensive study, while a fixed bridge, which involves no material difficulty, seems unlikely to be permitted, as hereinafter discussed.

"Previous studies have contemplated the use of a double-leaf bascule bridge similar to that at Wabash Avenue, which was found to require elimination of an important ramp to the C. & A. R. R. freight yards, together with a storage track of minor importance, and the use of a single-leaf bridge, which would avoid the ramp and track but might involve great engineering difficulties because of its enormous length.

"Drawing No. 15617 (Sheet 25) shows a divided or twin double-leaf bascule bridge with four trusses entirely below the deck, the leaves being offset so that, with the unimportant track eliminated, the ramp can be relocated and maintained. This bridge would require special control arrangements but involves no insurmountable difficulty. The bridge is shown to provide 170 feet clear channel, with 21 feet vertical clearance in the central 100 feet of the clear channel; although these clearances have not been submitted to the U. S. Engineer Office, they are believed to be acceptable for this type of bridge.

"Drawing No. 15618 (Sheet 23) shows a vertical lift bridge which offers a decided advantage in spanning the ramp and track substantially unchanged, and also would permit lower grades for the east approach, reducing construction and damage costs in an amount which would depend to some extent on the treatment employed. In all, the cost of this bridge may be about \$100,000 less than that of the divided bascule bridge.

"This study also shows a clear channel of 170 feet, but a vertical clearance of 21 feet for a width of 120 feet extending eastward from the west pier, and reducing gradually to about 20 feet at the east pier. Accordingly, this bridge would provide barge navigating conditions somewhat better than could be attained with the bascule bridge.

"Drawing No. 15619 (Sheet 24) shows one of the various types of fixed bridges which might be used if and when permitted. The Bridge Division has for many years recommended the construction of fixed bridges, which would result in great reductions in costs, but, for any bridge to be built at this location in the near future, it seems necessary to consider the improbability of obtaining a permit for a fixed bridge. The City now has pending an application for a fixed bridge over the North Branch at Fullerton Avenue, about $3\frac{1}{2}$ miles north of the Forks and only $1\frac{1}{2}$ miles from the head of navigation, but so far has not obtained a permit therefor.

"The study shows a bridge having steel trusses of the bow-string or tied arch type with vertical suspenders, the high midspan portion having overhead bracing. This bridge is shown to span substantially the entire width of the river, about 200 feet, and to provide 21 feet vertical clearance throughout; discussions with the U. S. Engineers, in regard to Fullerton Avenue bridge, indicate that such increases in clearances would be required for a fixed bridge to receive consideration, and they can be provided without serious increase in cost.

"Following are preliminary estimates of cost of the three bridges herein described. These estimates, using costs per square foot, are based upon analysis of previous bridge costs with allowances for major differences of design and differences in economic conditions, and are believed to be at least as reliable as estimates based upon quantities assumed in advance of fairly complete design.

"Twin Double-leaf Bascule Bridge:	
Center to center of anchor cols., 301 ft.; width 95 ft. 301' x 95', 28,595 sq. ft., @ \$47	\$1,350,000
"Vertical Lift Bridge:	
Center to center of rear tower cols., 317 ft.; width 100 ft. 317' x 100', 31,700 sq. ft., @ \$42	\$1,330,000
"Fixed Bridge:	
Center to center of bearings, 240 ft.; width 100 ft. 240' x 100', 24,000 sq. ft., @ \$20	\$ 480,000
East approach span 42' x 120' @ \$8	40,000
	\$ 520,000

"Although the above estimates indicate a difference of only \$20,000 between the bascule and the vertical lift, the former requires additional viaduct length, ramp and track relocation, higher east approach grades and other features which would add some \$60,000 to \$80,000 to the difference in cost."

The necessity for providing convenient means of ingress to and egress from the Congress Street thoroughfare just east of the river, lead to the development of a plan for a terminal plaza in the area bounded by Congress Street on the north, Lomax Place on the south, Wells Street on the east and the river on the west. This general plan is shown on Sheet 16 and provides for two 2-lane ramps for traffic with destinations north of Congress Street reached by either Franklin Street or Market Street. Movements to and from the superhighway at Wells Street should be restricted to vehicles making right turns only. Just east of the easterly bridge abutment the approach structure will be widened so as to provide two express roadways 34 feet in width and in addition, ramps 24 feet wide on each side, a total width of about 125 feet. The extensions of the ramps at street grade will be separated from the service drives planned along existing Congress Street and Lomax Place by four foot strips. The service roadways planned along Congress Street and Lomax Place will have ample capacity for local use. However, one-way traffic control on these two short local streets should be provided.

Each of the express roadways along Congress Street will be widened for a short distance west of Wells Street so as to facilitate right turns of southbound traffic on Wells Street into the westbound express roadway and also of eastbound express traffic making right turns southbound in Wells Street. The improvement as planned includes the opening of Market Street and the widening of the roadway of Franklin Street within the limits of the improvement and also the widening of Wells Street between Harrison Street and Van Buren Street.

The opening of Market Street will provide a direct connection by way of Market Street and Wacker Drive to points north of Congress Street and east and north of the Chicago River. Roadways of both Franklin and Market Streets are designed with center strips and, as supplemented by safety zones, provide for channelization of traffic in this terminal area. Sidewalk connections are provided on the viaduct between the east line of Franklin Street and the Congress Street bridge; stairways placed on the westerly line of Market Street and also on the east line of

Franklin Street providing convenient means for pedestrians to reach sidewalks on the elevated floor of the bridge.

Some consideration was given to the relative advantages of a steel structure or solid fill between concrete retaining walls for that portion of the improvement between Wells Street and the river. The open steel structure would provide additional parking space but the amount of space thus made available is limited. Further, the use of such space for a parking lot would conceivably constitute a serious impediment to the free movement of traffic in this area. It was concluded, therefore to plan this section as a solid fill. That such a design will produce an attractive plan is shown by the perspective of this section as shown on Figure 7.

In this connection, it should be noted that the underground space between Lomax Place and Congress Street and west of Wells Street is well adapted for the construction of the proposed subway loop. This tract of land, therefore serves a dual purpose.

The plan for this improvement recognizes the probability of an extension of Franklin Street to the south as has been proposed in the comprehensive superhighway plan to provide a major north and south thoroughfare terminating in the vicinity of Congress Street. The separation of grades herein proposed avoids any conflict between heavy streams of traffic in the future and the proposed roadway plan will provide for the division of traffic just south of Congress Street into Market Street-Wacker Drive and also Franklin Street to the north. The entire plaza as thus developed is to be suitably landscaped so as to constitute a dignified and attractive terminal for the entire grade separated thoroughfare to the west. A perspective of the proposed plaza viewed from a point east of Wells Street is shown in Figure 7. The selection of a vertical lift bridge was assumed for the purpose of this drawing.

The proposed traffic control throughout the terminal area is shown on Figure 27. All major movements are to be made by either straight crossing or right turn movements. Left turn movements at the river plaza should be limited to the following:

- (1) Southbound in Market Street at the North Service Drive—to move on east and west go signal.
- (2) South bound in Franklin Street at the North Service Drive—to move on east and west go signal.
- (3) Northbound from Franklin Street to Market Street at South Service Drive—to move on east and west go signal, and
- (4) Southbound from Market Street and Franklin Street to South Service Drive—to move on separate interval in each signal cycle.

Attention is specifically directed to the design of the two-lane ramps between Franklin and Wells Street. High cost of right-of-way in this terminal area made it advisable to limit the width of the plaza to 352 feet as shown on the plans. This requires a turn on the ramps with inner radii of 30 feet and outer radii of 54 feet. These turning radii are entirely practicable for passenger vehicles, but will require slowing down to speeds of about 15 to 20 m.p.h. In view of the fact that all

movements on ramps should be at relatively slow speeds, this would seem to impose no especial difficulty in the use of the ramps. Freedom of movement on these turns would be about equal to that experienced in making U-turns without traffic interference and utilizing the full width of such roadways as Michigan Avenue, Wacker Drive or State Street (south of the river).

However, a more convenient and commodious layout could be made by widening the plaza to extend one-half block north of existing Congress Street and one-half block south of Lomax Place. This would involve additional cost of approximately \$1,500,000—an expenditure which would not, in our opinion, be justified by the possible improvement in the plan.

The superhighway is planned to provide eight lanes for express traffic—four lanes in each direction—from Canal Street to the west city limits. Throughout this entire seven mile section, grades of the express roadways are to be completely separated from all cross streets for reasons given in the description of the plans both in the "subway zone" east of Throop Street and for the suggested development west of Throop Street, which follows:

Canal Street to Throop Street

The existing opening of Congress Street through the Post Office building definitely establishes the grade of the thoroughfare at Canal Street. In order to meet this grade (approximately + 24) and in order to avoid the closing of such important streets as Clinton, Jefferson and Desplaines Streets, it is necessary that the Congress Street thoroughfare be elevated in the area immediately west of Canal Street. While the proposed subway-elevated railroad incline will terminate near Halsted Street, it was necessary to extend the elevated section of the highway west far enough to avoid closing any of the more important north and south streets serving this rather intensively developed industrial and commercial zone. For that reason the improvement as planned consists of an elevated highway from Canal Street to Racine Avenue with an incline between Racine Avenue and Loomis Street, carrying the express roadways from elevated grade about + 31 to depressed grade about Chicago City Datum. This location of the incline would require the closing of Throop Street for through traffic, thereby inconveniencing a relatively small volume of traffic—typical week-day through traffic on Throop Street totaling approximately 1,100 and 1,200 according to counts made in 1934 and 1939 respectively.

West of Canal Street and extending to the west city limits a thoroughfare with adequate express roadways entirely free from interference with cross traffic and providing for uniform speeds of 40 m.p.h. or more is planned. For such high speed service, roadways should be designed with liberal width of traffic lanes so as to insure freedom of movement and maximum of safety. The adoption of a uniform lane width of 12 feet for such service is recommended. The express roadways west of Canal Street are designed for four lanes of traffic in each direction or a total width for each roadway of 48 feet.

The proposed elevated highway between Canal Street and Throop Street is shown in detail on Sheets 17, 18 and 19. The portion between Throop and Desplaines Streets is planned as a solid embankment changing to an elevated concrete steel structure between Desplaines and Canal Streets (see Sheets 20 and 21). The two express roadways are separated by a center strip 5 feet in width with an over-all width of embankment, including retaining walls, of 105 feet, decreasing to 104 feet for the structural section. The center strip is planned with a 5 foot width to provide adequate space for highway lighting standards and also for use as an emergency walk.

The provision of an elevated structure instead of the solid fill between Desplaines and Canal Streets would provide parking space more than 100,000 square feet in area under the structure at an additional cost of approximately \$150,000. The operation of a public pay parking lot in this location would be a convenience to motorists and business and would also earn more than enough to pay interest on the additional investment.

It is proposed to widen the roadway just west of Canal Street (see Sheet 16) so as to permit southbound vehicles on Canal Street to make right turns to the west on Congress Street and also to permit eastbound vehicles on Congress Street to make right turns to the south on Canal Street. Eastbound vehicles with destinations north of Congress Street can leave the express roadway at one of the ramps west of Canal Street and proceed to their destination after making a left turn into Clinton Street, Desplaines Street or Morgan Street. Ramps are provided at these three locations to provide for traffic to and from the near west side area.

The plans provide for widening the roadway and repaving Morgan Street, Desplaines Street and Clinton Street between Harrison Street and Van Buren Street and also for installing traffic actuated signals at the intersection of these thoroughfares with the Congress Street ramps so as to facilitate traffic movements and insure the safety of vehicles making right and left turns to and from these ramps. Photographs showing the present character of building development along the proposed right-of-way in this area are shown on Figures 8, 9 and 10. Figure 8 shows a view west along Congress Street from the fifth floor of a building on the east side of Jefferson Street. Figure 9 shows the existing buildings on the north side of Congress Street west of Sangamon Street. Figure 10 shows a view of the north side of Congress Street east of Racine Avenue.

A SUGGESTION FOR A SUPERHIGHWAY DEVELOPMENT WEST OF SUBWAY ZONE

While not directly involved with the extension of the subway system, a general plan for the opening and widening of Congress Street west of the subway zone has been prepared to show a logical extension of the west side superhighway project to the city limits and to develop the feasibility of the entire scheme (see Sheets 26 and 27).

The half mile section west of Throop Street is mixed residential, commercial and industrial in character. Between Ashland Avenue and Damen Avenue the

thoroughfare as planned would skirt the north end of the proposed medical center utilizing a right-of-way now largely occupied by commercial and residential buildings. From Damen Avenue to the west terminal at Columbus Park the right-of-way is planned through a district largely devoted to residential use, except for a moderate amount of commercial development along Van Buren Street and for tracts devoted to industrial use in the immediate vicinity of the Belt Railway, the Chicago and North Western Railway and the P. C. C. and St. L. Railroad.

Depression of Express Roadways Suggested

Careful consideration was given to the type of grade separation to be planned in the area west of Throop Street. The 1935 State Highway Plan provided for the depression of the express roadways under principal intersecting streets but in 1938 the Engineers Committee on West Side Superhighways recommended that the 1935 plan be modified by elevating the express roadways. The principal reason for such recommendation as stated in the 1938 report was that the plan then proposed provided for the separation of grades only at the principal thoroughfares—approximately one-half mile apart and that, in the opinion of the Committee, complete separation throughout would be required eventually and further, that the step between the initial plan and the final plan for complete grade separation could be accomplished at less cost and with less interference to traffic by the elevation of the express roadways rather than their depression.

The present plan suggesting the complete separation throughout would seem to eliminate this factor. While the right-of-way in which the express roadways will be located will be of sufficient width to permit suitable treatment of the marginal parkways in any case, it seems obvious that the depression of the thoroughfare, rather than an elevated structure would provide a more attractive and beneficial improvement from the viewpoint of the surrounding areas. Some additional cost would be involved in the reconstruction of publicly and privately owned utility lines across the depressed thoroughfare and in a number of cases existing sewers must be siphoned under the cut. However, the difference in cost is not sufficient to make this a major factor in the determination of a type best suited to benefit the entire area.

The question of snow removal and drainage is sometimes raised as an argument against depressed thoroughfares. Reference to the suggested cross sections shown on Sheet 28 shows that berms at each side of the roadways provide space for the temporary storage of snow. Drainage would be provided by the construction of a complete new system connected to sumps from which storm water will be pumped to the existing sewer system.

From the viewpoint of the motorist the provision of a wide landscaped right-of-way will provide attractive surroundings irrespective of the elevation or depression of the thoroughfare. Safety is promoted by depression in that this type of improvement provides the maximum of visibility at the intersection of ramps and approaches with service driveways and intersecting streets. While it is required that

traffic signals be installed at the intersections of the connecting roadways with the more important north and south thoroughfares, there is no question but that the full vision afforded by depressed highways to all approaching motorists at intersections is vastly superior to that afforded by elevation, where motorists leaving the express roadways cannot see approaching vehicles on cross streets—their view being obstructed by the adjacent elevated structures. It would seem, therefore, that the depression of express roadways is advisable where feasible and the plans submitted herewith provide for such design through all of the areas where it is adaptable including both residential and commercial districts. Further, this type of highway is strongly advocated by the Public Roads Administration, Federal Works Agency under the conditions present here and it is doubtful if Federal aid could be made available for a design which did not conform as far as possible with this recommendation.

Alignment

The suggested alignment from Throop Street to the city limits is shown in Sheets 26 and 27. The location of the existing elevated structure of the Chicago Rapid Transit Company has a definite influence on the alignment of the thoroughfare east of Sacramento Boulevard. The problem of crossing the elevated railroad structures in the vicinity of Marshfield Junction presented a number of difficulties. East of this junction (Paulina Street), it is suggested that all of the right-of-way between the existing south line of Congress Street and the four-track elevated railroad structure on the north be acquired, providing a total width of right-of-way of approximately 225 feet. The typical cross section shown on Sheet 28 illustrates the type of development suggested. The two 48 foot express roadways divided by an 8 foot center strip are depressed below the normal street grade. After providing for a strip 40 feet in width for sidewalk, parkway and service drive on the south side, there would remain a section 35 feet in width for a sloped parkway on the south side and about 46 feet in width for a similar parkway on the north side of the express roadways. Through the landscaping of these slopes, the existing elevated structure on the north could be effectively screened and a pleasing treatment afforded the entire section. Figure 11 shows a photograph of the property along the north side of Congress Street taken from a point near Racine Avenue. This is the location of the suggested right-of-way in this section.

West of Ashland Avenue it is proposed to deflect the line of the thoroughfare to the north by reverse curves with radii of 2,000 feet so as to locate the improvement between the north line of Van Buren Street and the north line of the Chicago Rapid Transit Company elevated structure, as shown on Sheet 30. This layout would avoid the expensive Y. M. C. A. and the Nurses Home buildings in the vicinity of Wood Street and would provide an attractive and suitable north border for the medical center now in process of development. These structures on the north side of Congress Street as well as the University Hospital at Wolcott Avenue are shown in the photograph taken from a point near Paulina Street as shown on Figure 12. The total width of right-of-way available west of Wood Street is

approximately 250 feet. The cross section planned is shown on Sheet 28 and is similar to that between Marshfield Avenue and Loomis Street, except for the wider roadway (38 feet) required for two-way traffic on Van Buren Street.

Between Sacramento Boulevard and Garfield Park a second change in alignment is suggested. This would be accomplished by easy reversed curves as shown in some detail on Sheet 31. The relatively low cost of right-of-way of this district is such as to warrant the acquisition of the entire block between Van Buren Street and Congress Street so as to provide an over-all width between existing street lines of almost 400 feet. A view of property on the south side of Van Buren Street taken near Central Park Avenue (see Figure 13) shows the character of the present development in this section. The roadway would be depressed below normal street grade and the ample right-of-way width would practically eliminate the expensive retaining wall construction involved in ramp construction, and permit the use of flat slopes easily maintained and providing exceptional opportunities for satisfactory landscaping treatment as shown on the typical cross section on Sheet 28. Figure 14 shows a perspective of the thoroughfare in the section between Garfield Park and Columbus Park.

A careful study of building development, land costs and other factors in that section of route between Garfield Park and Columbus Park lead to the selection of the strip between Gladys Avenue and Van Buren Street with a total width of right-of-way of almost 400 feet. Figure 16 shows a view looking west between Gladys Avenue and Van Buren Street from Laverne Avenue. This location would require a deflection in the alignment through Garfield Park as shown on Sheet 32. The location selected has a further advantage in that a satisfactory connection can be provided at Columbus Park, both to Jackson Boulevard and to the roadways to be constructed around the southerly side of Columbus Park, extending west to a connection with an extension of the west side superhighway to be developed subsequently through the west suburban district (see Sheets 33 and 34).

The alignment as suggested avoids dislocation of large industrial plants or other large going concerns. It also permits logical development of the proposed medical center. While there are a number of offsets in the line, easy long radius curves are planned throughout permitting vehicles to travel with safety at 60 miles per hour if necessary.

Efficiency of Improvement as Planned

The function of the west side superhighway is to provide a safe and convenient facility for the segregation of through east and west traffic from local vehicular and pedestrian traffic. Detailed studies of probable initial use of the express roadways have been made, based on an analysis of the present movements of passenger vehicles on all of the east and west thoroughfares in the two mile section between Chicago Avenue on the north and Roosevelt Road on the south. These studies are discussed in some detail in Appendix 1. The real test of a highway occurs during a relatively short period of maximum use. Therefore, all of these studies have been directed

toward a determination of the use during the maximum 30-minute period of the morning rush hour on the eastbound roadway. Similar and parallel conditions can be assumed on the westbound roadway during the maximum 30-minute period of the evening rush hour. This data is all summarized on the traffic flow charts (see Figures 17 and 18). Figure 17 shows existing inbound passenger vehicle traffic west of the Chicago River during the maximum 30-minute period as determined by counts made on typical week-days late in 1938 and in 1939. Figure 18 shows the estimated diversion to the west side superhighway and the redistribution of traffic on the existing streets. The following tabulation shows at several sections the working capacity of the eastbound express roadway and the estimated initial use during the maximum 30-minute period:

ESTIMATES OF TRAFFIC FLOW ON EASTBOUND ROADWAY
MAXIMUM 30-MINUTE PERIOD

<i>At</i>	<i>Capacity</i>	<i>Initial Use</i>	<i>Per Cent Initial Use of Capacity</i>
Central Avenue	3,000	1,100	37
Cicero Avenue	3,000	1,300	43
Kedzie Avenue	3,000	1,615	54
California Avenue	3,000	1,810	60
Ashland Avenue	3,000	2,020	67
Desplains Street	3,000	1,445	48
River Bridge	2,250	1,250	42
Sherman Street	1,500	800	53
Plymouth Court	1,500	390	26

It will be noted that the thoroughfare as planned has ample capacity to accommodate substantial increments in traffic throughout its entire length. The summary of data on ramps and connections shown in Appendix 1 indicates a maximum ratio of estimated use to capacity of 64 per cent.

No attempt has been made to estimate the increases in traffic volumes which will result from the additional and vastly improved facilities for travel provided by the proposed improvement. Past experience in Chicago has shown that new and improved transportation facilities invariably induce substantial increases in traffic. However, the latent capacity of the thoroughfare as planned is so great as to warrant the belief that it will accommodate all prospective increases in traffic and provide adequately for the needs of the areas served for a considerable period in the future.

In this connection the comprehensive program for superhighway construction to be undertaken jointly by the City of Chicago, the County of Cook and the State of Illinois is of especial interest. Due to the fact that existing radial thoroughfares extending northwest and southwest from Chicago's central business district are, in general, along narrow streets lined with stores and passing through numerous business centers—much of the traffic originating northwest and southwest of the city flows to the central area over the east and west and north and south thoroughfares rather than attempting to utilize the congested diagonals.

In the absence of a comprehensive origin and destination count, it is impossible to estimate the volume of traffic originating northwest and southwest of the central area which now uses thoroughfares such as the Outer Drive and Roosevelt Road, Jackson Boulevard and Washington Boulevard and which would be diverted to new grade separated superhighways extending northwest and southwest when built. It seems reasonable to assume, however, that the construction of the contemplated northwest and southwest superhighways will result in a balanced distribution of traffic flowing to and from the central business district from all points near and beyond the periphery of the city. The result of such balanced distribution undoubtedly will be to relieve existing traffic congestion both on east and west thoroughfares and on the north and south outer drives.

Ramps and Connections

Ramps have been planned with a view to providing connections to the express roadways which would include the following features:

1. The use of gradients which require no special skill in automobile operation and which would permit safe operation even during periods of ice and snow.
2. Widths sufficient to accommodate sudden and abnormal surges in traffic greatly in excess of normal and maximum use.
3. The provision of adequate storage space—approximately level in grade—at the bottom of the incoming ramps to permit the temporary storage of entering vehicles awaiting an opportunity to enter the express roadways without interrupting the smooth flow of traffic thereon. In the case of exit ramps storage is provided at the normal street level so as to insure the use of the incline sections for moving traffic and permit the vehicles leaving the express roadways to be temporarily stored at the nearby street intersections awaiting an opportunity to distribute in the normal traffic streams. This will insure no backing up of vehicles on either the express roadways or on the connecting street system.
4. The installation of warning and traffic control signals advising the motorists in advance of the location of exit ramps and requiring entering vehicles to come to a full stop before entering the express roadways.
5. The installation of traffic actuated signal control at all intersections where traffic along ramps or service drive connections intersects any volume of vehicular or pedestrian traffic on cross thoroughfares.
6. The provision of adequate and easy accelerating and decelerating lanes for vehicles entering or leaving express roadways.
7. The adoption of a standard pavement wearing surface on the ramps and connections radically different in color from that used on the express roadways. This will provide a visual aid to the motorist in locating and utilizing the ramps and their connections. This may be accomplished by the construction of a light colored Portland cement concrete pavement on the express roadways and the installation of an asphaltic wearing surface on the paving of the accelerating and decelerating lanes as well as the ramps and service drive connections.

In addition to the grade separated connections at the east and west termini, adequate connections to intermediate focal points and intersecting thoroughfares are afforded through the liberal provision of ramps. Practically all of the ramps are designed with a liberal width of 24 feet so as to provide for two lanes of moving traffic. Widening of the express roadways so as to provide lanes for acceleration and deceleration in the vicinity of the ramps is also incorporated in the design. The gradients utilized on the ramps vary in general from 3 to 5 per cent, although in one or two cases gradients of 6 per cent have been utilized in order to avoid the closing of important cross streets.

Detailed studies have been made of the initial use and capacity, not only of the express roadways but also of the proposed ramp and roadway connections. These studies are somewhat technical in character and will be found in Appendix 1 for the use of engineers and others who are interested in these phases of the problem.

The ramps and connecting roadways have been purposely planned generously so as to provide ample capacity for any traffic situation which may reasonably be expected to develop in the future. It should be pointed out that the summarized traffic estimates, developed in some detail in Appendix 1, are based on conditions as established by counts on normal week-days. The possibility—always present in large metropolitan centers—of large concentrations of traffic at special focal points such as large industrial plants or amusement centers, must be provided for. Two-lane ramps as planned will in many cases be much more than adequate for normal traffic. However, the proposed plans insure facilities adequate for handling traffic originating or routed to almost any nearby center, preventing traffic jams, inconvenient delays or interference with other traffic movements in the vicinity.

The layout of the ramps and connecting roadways has been planned with a view to securing a smooth flow of traffic into and out of intersecting and distributor streets. Ramps and connections are designed with ample storage capacity so as to insure no backing of vehicles into the express thoroughfares.

Intersecting Streets

The depression of the express roadways through the entire section west of Throop Street permits the construction of overpasses or bridges at all of the intersecting and cross streets where the volume of traffic is such as to warrant the cost. General Plans—Sheets 26 and 27—show the location of the overpass structures suggested initially. The cross streets for which no bridges are planned are largely local in character and carry but relatively small volumes of through traffic.

Traffic surveys made by the Street Traffic Bureau of the Department of Public Works with the aid of W. P. A. personnel during 1938 and 1939 show traffic on all of the north and south streets between Canal Street and Central Avenue which would be closed initially as follows:

SUMMARY OF PRESENT 16 HOUR TRAFFIC MOVEMENTS ON NORTH AND
SOUTH STREETS WHICH WILL BE TERMINATED AT SERVICE DRIVES
ALONG THE PROPOSED WEST SIDE SUPERHIGHWAY

<i>Street</i>	EXISTING STREET EXTENDS		<i>North and South Traffic at North Line Harrison Street Total for 16 Hours</i>
	<i>From</i>	<i>To</i>	
Throop	Harrison	Washington	1,266
Marshfield	Roosevelt	Jackson	1,044
Hermitage	Roosevelt	Jackson	925
Honore	Harrison	Madison	930
Wolcott	Milwaukee	Blue Island	1,826
Winchester	Roosevelt	Madison	557
Hoyne	Lexington	North	897
Bell	Harrison	Monroe	684
Claremont	Harrison	Van Buren	426
Maplewood	Harrison	Van Buren	115
Francisco	Roosevelt	Carroll	1,078
Albany	26th Street	Fifth	1,269
Trumbull	Harrison	Fifth	247
St. Louis	Harrison	Fifth	209
Springfield	Cermak	Madison	868
Karlov	20th	Kinzie	1,187
Kildare	14th	Kinzie	1,568
Kolmar	Harrison	Jackson	321
Leamington	Fifth	Madison	477
Lockwood	Fifth	Madison	601
Total			16,495

The above figures were obtained from traffic counts taken at the intersection of these streets with Harrison Street. The tabulation set forth here is for the total north and south passenger and service vehicles passing the intersection between 7:00 A. M. and 11:00 P. M. Of these volumes of traffic, passenger vehicles account for 69 per cent and service vehicles the remainder.

There were several streets on which no data was available and some of which partial data only could be secured. Those on which no data was available are listed as follows:

Rockwell Street
Talman Avenue, and
Spaulding Avenue

These streets are short, extending only one or two blocks long, ending at the present time either at Congress Street as a north limit or Van Buren Street as a south limit. Therefore, the traffic they carry would not be affected by the proposed superhighway.

It should be noted that in every instance connections are available for traffic moving across the west side superhighway over adjacent streets never more than 660 and usually 200 to 300 feet distant. The total traffic on all north and south

streets between Canal Street and Central Avenue as counted at Harrison Street is 244,816. Thus, the traffic which will be slightly inconvenienced by closing roadways across the superhighway—16,495 vehicles—amounts to only 6.8 per cent of the total north and south movement.

One of the great advantages of the depressed highway is its flexibility. For instance, if it should be found in the future that public convenience required the opening of one of these streets across the superhighway, it could be accomplished by building a bridge at the location in question—at the same time maintaining traffic on the thoroughfare.

Typical plans of the proposed bridges or overpass structures are shown on Sheet 29. It is suggested that these bridges be constructed of concrete providing simple and inexpensive architectural treatment through the use of concrete in its true functional character with no elaborate embellishment. The wide right-of-way as planned affords an opportunity for effective landscaping near abutments and retaining walls which should enhance the appearance of the finished structures. A perspective of a superhighway of the depressed type near a typical overpass structure is shown on Figure 15 and illustrates the possibilities for effective treatment.

A variation from the monotony of long sections of roadways on tangents with flat grades is afforded through the variations in alignment above noted and also through the use of a slightly rolling grade line. Care has been taken, however, to limit the gradients on the express roadways to a maximum of 3 per cent and in most cases gradients of from 1 to 2 per cent would be utilized.

Parallel Service Drives

Except for the section of the improvement east of Wells Street and certain sections of the thoroughfare where either the north or south line abuts the existing right-of-way of the Chicago Rapid Transit system (thereby eliminating any necessity for drives serving abutting property) parallel service drives are provided throughout the entire improvement. In a number of instances existing traffic control will of necessity be modified to conform to the west side superhighway development. Obviously, service drives function with the greatest efficiency as one-way roadways, so that in general the parallel roadway on the south should be limited to eastbound traffic and the roadway on the north to westbound traffic. Due to the short distance between intersecting streets and the much greater efficiency of the service roadway proper, one-way traffic would be to the advantage of the abutting property as well as facilitate the free flow of traffic to and from ramp connections to the express roadways.

The existing streets now open to two-way traffic which should be thus changed to one-way traffic are as follows:

	<i>From</i>	<i>To</i>
Congress Street	Wells Street	Market Street
Lomax Place	Wells Street	Franklin Street
Congress Street	Clinton Street	Jefferson Street
Congress Street	Desplaines Street	Halsted Street
Tilden Street	Desplaines Street	Halsted Street
Congress Street	Halsted Street	Ogden Avenue
Congress Street	Sacramento Boulevard	Central Park Avenue
Van Buren Street	Hamlin Avenue	Central Avenue
Gladys Avenue	Hamlin Avenue	Central Avenue

That extremely small volumes of traffic would be affected by the suggested one-way traffic control is shown by 1938-1939 counts tabulated below, which show the volume of traffic for the 16 hour period—7:00 A. M. to 11:00 P. M.—now using the streets in question. The data was obtained from counts taken on the principal north and south thoroughfares intersecting these streets. The volume of traffic listed here includes all passenger and service vehicles both eastbound and westbound. The passenger vehicles comprise an average of 60 per cent of the total. The percentage of total traffic that is eastbound and the percentage that is westbound is also given. Finally, the number of vehicles occurring in the maximum 30-minute period for each direction is listed.

TABULATION OF PRESENT TRAFFIC ON STREETS PARALLEL AND ADJACENT
TO THE PROPOSED WEST SIDE SUPERHIGHWAY

<i>Location</i>	TOTAL TRAFFIC		PERCENTAGE		MAXIMUM ½ HOUR	
	<i>West of Intersection</i>	<i>East of Intersection</i>	<i>East Bound</i>	<i>West Bound</i>	<i>East Bound</i>	<i>West Bound</i>
<i>Gladys Avenue at</i>						
Central		609	49	51	12	14
Laramie	571	516	55	45	23	29
Cicero	807	559	50	50	25	23
Pulaski	1,000	1,096	40	60	25	56
<i>Van Buren Street at</i>						
Central		631	51	49	9	15
Laramie	612	607	50	50	15	28
Cicero	937	1,043	47	53	23	36
Pulaski	937	766	49	51	17	25
<i>Congress Street at</i>						
Kedzie	1,134	1,179	50	50	27	44
California	1,082	937	49	51	39	39
Western	1,128		66	34	22	16
Damen	719	833	32	68	19	66
Ogden	1,302	1,948	43	57	67	105
Asbland	1,998	2,139	44	56	122	140
Halsted	1,476	746	60	40	66	54

The operation of the existing street car route on Van Buren Street east of Kedzie Avenue does not permit the conversion of this street into a one-way street east of Kedzie Avenue. Therefore, special care has been taken in the layout of the ramps connected to that portion of the Van Buren Street roadway with two-way

traffic so as to prevent unnecessary and troublesome traffic interference—see Sheets 26, 30 and 31.

In a number of instances advantage has been taken of the wide right-of-way to smooth out the alignment of the service drives. Instances of such improvement are found on Congress Street just west of Desplaines Street, just west of Halsted Street and just west of Albany Avenue.

Traffic Control

Traffic actuated signals are planned at the intersection of all ramps and connecting roadways with intersecting thoroughfares. Vehicles entering express thoroughfares from ramps should be required to stop at the junction of the ramp with the express roadway. Accelerating and decelerating lanes, generally about 300 feet in length, are provided at all such junctions so as to afford an opportunity for the entering and leaving vehicles to accelerate and decelerate and merge with and depart from the flow of through traffic along the express roadways.

On the express roadways proper no traffic control signals will be required in the entire section between the west city limits and Canal Street. Signs disclosing the location of ramps and connections and stating speed limits will be all that is required. Speed control should be such as to require vehicles to move within a narrow range of approximately 40 m.p.h. Police regulation should be continuous and should control not only maximum speeds but also minimum speeds so as to insure smooth flow of traffic.

The parkways are provided with berms of sufficient width to permit disabled cars to leave the roadway and be temporarily stored on the adjacent parkway just beyond the outside curb. Police control should include the provision of emergency towing equipment to remove all disabled vehicles. Use of police cars with two-way radio now provides an efficient means of meeting traffic emergencies.

Special traffic control will be required at Canal Street, at the Post Office ramps, at the roadway on the east side of the Post Office building and at Wells Street, and at all street intersections east of Wells Street. Except for the intersection with the Post Office ramps and the roadway just east of this building, where the signals should be traffic actuated, all other signals will be of the standard time control type with cycle divided in accordance with the traffic volumes to be accommodated.

Express Bus Operation

The plans for modernization of the city's local transit facilities include the operation of a number of express bus routes. The superhighway herein suggested would provide admirable facilities for such operation. The final plans, therefore, should include a limited number of stops where the roadway should be widened to permit express buses to load and unload passengers without interfering with the smooth flow of traffic on the four express lanes in each direction. Platforms and stairways leading to the sidewalk on the intersecting street above or below should

also be built. The facilities here suggested are for express buses only—no buses making local stops should be permitted.

Construction Details

Relatively shallow curbs with a smooth rolling contour are proposed for all of the depressed sections of the express roadways. The use of this type of curb together with the berms and flat slopes proposed for the embankments permits disabled automobiles to be temporarily stored on the parkway adjacent to the curb. In this way the full use of the outer lanes of the express roadways can be secured.

It is also planned to construct curbs with reflecting surfaces normal to the headlight rays and driver's vision. These may be provided by means of a saw tooth profile in the surface of alternate sections of the curb. The reflecting faces may be designed with such spacing that a continuous band of reflected light is presented to the driver's view. The exposed surface of the reflecting face is painted white. This type of curb has the great advantage of definitely outlining the edges of the roadway particularly at night and has an increased effectiveness on rainy nights due to the fact that the film of water over the reflection face increases the intensity of reflection.

The orderly and efficient use of express roadways requires permanent markers properly to divide them into traffic lanes. It is suggested that permanent lane markers be incorporated into the pavement by one of the practical, low cost methods recently developed.

Lighting

Exhaustive studies of day and night accidents and the improvement in safety on highways resulting from the provision of suitable lighting has proven the necessity for providing high visibility to make effective the safety features built into a modern superhighway carrying large volumes of high speed traffic. For instance, the provision of a modern type of street lighting in Detroit recently reduced the ratio of night deaths to day deaths from 7 to 1 from before to approximately 1.5 to 1 after the lighting improvement.

In the design of lighting for the west side superhighway, the installation of lights to provide satisfactory visibility and at the same time be free from glare and reflections disturbing to the motorists, was the objective. Two types of lights are available, both having been utilized with success:

- (1) The ordinary incandescent lamp provided with special reflectors and refractors permitting close control of the light distribution; and
- (2) The sodium vapor lamp which has been utilized with considerable success both on rural highways and more recently in urban centers.

It has been found that efficient distribution of light over the pavement surface of the express roadways may be secured by use of two light standards located in the parkway near the outer curb of each of the roadways. This involves a slightly greater initial cost than the single center standard installation—but the operating costs are the same. The increase in efficiency seems to warrant the slightly increased cost of installation of the side lights where feasible. Standards would be approximately 27 feet in height and should be provided with an 8 foot bracket. The

spacing of the standards on centers of 125 feet with the use of a 10,000 lumen sodium lamp would produce average lighting intensities from 0.2 to 0.6 foot candles on the pavement surface. Special parapet lighting fixtures should be designed and installed under all overhead bridges so as to insure uniformity of roadway lighting.

The cost estimates include express roadway lighting as well as suitable lights for ramps and connections and on all new service driveways to be constructed as a part of the project. No allowance is made for the installation of new street lights on existing roadways to be incorporated in the superhighway and utilized as service driveways. New street lights for those portions of cross streets within the limit of improvement however, are contemplated.

Estimates of Cost

Cost estimates are based on prevailing labor and material costs and land and building values. Data on land and building values was made available through the cooperation of the County Assessor through which the 1938 assessed values were utilized as a basis for determining present day actual values. The advice of the city's real estate appraisers was secured in determining factors to be applied to the assessments in determining present fair cash market value in the several areas studied. It is interesting to note that there has been a substantial shrinkage of real estate values in this area since the preparation of the State Highway Department Plan in 1935. The estimates which include an allowance of approximately 20 per cent for engineering, legal, overhead costs and contingencies are set forth in Appendix I and are summarized as follows:

ESTIMATE OF COST OF WEST SIDE SUPERHIGHWAY

<i>Section</i>	<i>Length in Miles</i>	<i>Land and Buildings</i>	<i>Construction</i>	<i>Total</i>
Michigan to State	0.17		\$ 120,000	\$ 120,000
State to Clark	0.16	\$1,550,000	90,000	1,640,000
Clark to Wells	0.15	1,030,000	2,210,000	3,240,000
Wells to Chicago River	0.15	1,750,000	430,000	2,180,000
Chicago River Bridge	0.15*		1,350,000	1,350,000
Canal to Desplaines	0.23	710,000	1,000,000	1,710,000
Desplaines to Throop	0.79	1,100,000	1,930,000	3,030,000
Throop to Ashland	0.37	320,000	680,000	1,000,000
Ashland to Damen	0.50	575,000	1,660,000	2,235,000
Damen to Western	0.50	560,000	890,000	1,450,000
Western to California	0.50	560,000	1,010,000	1,570,000
California to Kedzie	0.50	700,000	730,000	1,430,000
Kedzie to Central Park	0.50	960,000	690,000	1,650,000
Central Park to Pulaski	0.50	1,000,000	930,000	1,930,000
Pulaski to Kostner	0.50	980,000	630,000	1,610,000
Kostner to Cicero	0.50	960,000	860,000	1,820,000
Cicero to Laramie	0.50	640,000	650,000	1,290,000
Laramie to Central	0.50	990,000	730,000	1,720,000
Central to Austin	0.50		490,000	490,000
Totals	7.67	\$14,385,000	\$17,080,000	\$31,465,000

* Including section between bridge and Canal Street.

A comparison of the above cost estimate with those made by the State Highway Department in 1935 and by the Committee on West Side Superhighways in 1938 may be made by including only those sections between Wells Street and Austin Boulevard, the limits of the improvements proposed in the 1935 and 1938 reports. This comparison is as follows:

COMPARATIVE ESTIMATES—WELLS STREET TO WEST CITY LIMITS

	<u>Land and Buildings</u>	<u>Construction</u>	<u>Total</u>
1935 Report	\$13,470,000	\$ 7,790,000	\$21,260,000
1938 Report	15,684,000	8,570,000	24,254,000
1939 Plan	11,805,000	14,660,000	26,465,000

In considering the above figures it should be noted that the 1939 plan has numerous advantages lacking in the other two plans. The 1935 and 1938 plans provided for the separation of grades of the express roadways only at the more important intersecting streets, whereas this project provides for the complete separation of the express roadways from all local and cross traffic, both vehicular and pedestrian. The 1939 plan also provides substantially increased widths of right-of-way, greater width of ramps and connections, fewer closures of cross streets, improved and safer facilities for pedestrians, and wider roadways. These improvements have been effected at a relatively small increase in total cost.

AN ALTERNATE PLAN FOR THE WEST SIDE SUPERHIGHWAY
INCLUDING DEPRESSION OF RAPID TRANSIT TRACKS
BETWEEN HALSTED STREET AND SACRAMENTO
BOULEVARD

An alternate plan has been prepared for the Congress Street subway extension and the west side superhighway, broader in scope and more costly, but with a number of advantages as compared with the plan described hereinabove. The alternate scheme differs from the original mainly in the extension of the subway westward in an open cut, parallel to the express roadways of the west side superhighway so as to extend the west side subway service from Halsted Street to Kedzie Avenue. This alternate plan would produce the following results:

Remove the existing Garfield Park elevated structure throughout the entire section from Racine Avenue to Sacramento Boulevard;

Eliminate the operation of the Logan Square and Humboldt Park trains on the Paulina Street elevated structure south of Lake Street;

Provide new and modern rapid transit stations on the proposed west side subway extension at section and half section line streets as compared with the existing elevated stations spaced approximately one-third of a mile apart;

Permit the installation of a third track for express service between Marshfield Avenue and Sacramento Boulevard; and

Provide an opportunity for widening the right-of-way of the project through the mid-city section with resulting benefits both to nearby property and motorists.

No major change in the original plan for superhighway and subway development east of Desplaines Street or west of Kedzie Avenue is required, the alternate suggested herewith relating only to the three mile section between these thoroughfares.

Express Roadway Layout

In the alternate plan the incline of the express roadways—from elevated grade to depressed grade—is shifted from the location just west of Racine Avenue to a location just west of Desplaines Street—see Sheet 35. This is permitted through the elimination of the elevated-subway incline between Desplaines and Halsted Streets which requires raising the street grade at Desplaines Street and lowering it at Halsted Street. The effect of this would be to extend the depressed section of the superhighway approximately $\frac{5}{8}$ of a mile farther east and would confine the elevated highway structure to the short section between Desplaines Street and Franklin Street. No change in width or type of the express roadways is involved in the alternate plan.

Connecting driveways at a level grade would be provided in the alternate plan in lieu of the ramps just west of Desplaines Street. The Morgan Street ramps provided in the original plan descending from elevated grade to street grade would be replaced by ramps ascending from depressed grade to street grade—see Sheet 36. The four ramp connections originally proposed at Throop Street would be eliminated in the alternate plan, which provides for ramps connecting the express roadways (depressed) to service drives at normal street grade just east and just west of Loomis Street—see Sheets 37 and 38.

The ramp from Paulina Street to the eastbound express roadway originally suggested would be shifted west to Wood Street with a connecting roadway to Ogden Avenue, a somewhat better arrangement than the original layout which required eastbound vehicles to travel from Ogden Avenue near Wolcott Avenue to Paulina Street along the existing Congress Street roadway. The ramp extending from the westbound express roadway to Wood Street will remain in the same location but the layout will be somewhat improved due to the improvement in alignment offered by the alternate plan—see Sheet 38.

At Damen Avenue the general pattern of four-way ramp development will be similar but the wider right-of-way provided in the alternate plan effects a slight improvement in the ramp layout. This is also true of the ramps at Oakley Boulevard, at Campbell Avenue and at Sacramento Boulevard—see Sheet 38.

Congress Street Subway Connection

The alignment of the proposed Congress Street subway east of Canal Street is unchanged from the original plan. West of Canal Street, however, the center line at the subway is deflected slightly to the south rather than the north so as to locate the center line of the subway portal (just west of Desplaines Street) about 60 feet north of the south line of Congress Street instead of about 70 feet south of the north line of Tilden Street. Instead of extending up on an incline west of Desplaines Street to connect to the existing elevated railroad tracks west of Halsted Street, the alternate plan suggests the extension of the subway tracks westerly along the south side of the Congress Street improvement from Desplaines Street to the Ashland Boulevard transfer station as shown on Sheets 35, 36, 37 and 38.

Metropolitan Elevated Railroad Tracks

Two of the existing four elevated tracks between Peoria Street and the Chicago River would be eliminated for main line service and—if not required for storage—could be removed. The two northerly elevated tracks would be connected to a new elevated structure extending diagonally across the express roadways of the superhighway and also across the two depressed subway extension tracks to a location just north of the north curb line of the service drive along the south side of the improvement. A two-track elevated structure would be built in the short block between Sangamon Street and Morgan Street and then descend to depressed roadway grade on an incline with a gradient of 3.0 per cent, the incline extending from Morgan Street to a point about 200 feet east of Racine Avenue. This special construction is illustrated in the perspective reproduced on Figure 29.

Thus, four depressed rapid transit railroad tracks would be provided extending along the south side of the improvement from a point east of Racine Avenue to Marshfield junction permitting the removal of the existing elevated railroad structure in this section. A local station is planned serving two tracks at Racine Avenue and an express station serving all four tracks at Ashland Boulevard. East of the Ashland Boulevard station, an interlocking plant would provide for the necessary interchange between tracks from the several branches of the rapid transit system west of Marshfield junction to either the Congress Street subway or to the elevated railroad east of Racine Avenue, as shown on Sheets 38 and 42. It would be necessary to remove all existing elevated railroad structures in the vicinity of Marshfield junction including the structure now used for Logan Square and Humboldt Park service—the need for which will be virtually eliminated through the construction and operation of the Dearborn Street subway now under construction.

Douglas Park Branch

It would also be necessary to remove all of the existing Douglas Park branch elevated structure north of Taylor Street and to construct in lieu thereof two rapid transit tracks at depressed track grade on a new alignment extending somewhat westerly of the present location. A new station would be built at depressed grade at Flournoy Street with an incline extending from Polk Street to Taylor Street

providing for a connection between the new depressed tracks and the existing elevated structure at Taylor Street. This alternate layout is shown on Sheets 40 and 42.

Garfield Park Branch

The alternate plan involves the removal of the existing Garfield Park branch elevated structure between Marshfield junction and Sacramento Boulevard and the construction of a three-track rapid transit railroad built at depressed grade from Marshfield junction to a connection to the existing elevated structure near Kedzie Avenue. The details of the proposed connection are shown on Sheets 41 and 42 and show a two-track subway-elevated incline extending from Harrison Street just west of Sacramento Boulevard to a connection to the existing elevated structure just east of Kedzie Avenue. The present elevated structure east of Kedzie Avenue and extending north to Congress Street near Sacramento Boulevard would also be removed. This location of the incline involves the closing of Albany Avenue between Harrison Street and Flournoy Street.

Two new local stations would be provided serving the two outside tracks, one at Damen Avenue and the second at California Avenue. An express station with island platforms serving all tracks is planned at Western Avenue. In this way modern station spacing and express service so long needed on the west side would be provided. The track construction and stations would be modern in every respect and safety would be insured by the installation of electric block signals and automatic train stops on all of the new depressed rapid transit tracks.

Alternate Alignment—Racine Avenue to Sacramento Boulevard

Typical cross sections showing the location of the rapid transit tracks with respect to the express roadways are shown on Sheet 39. Ramps would be located in the space between the north tracks and the south express roadway in all instances so that in no case will there be any conflict between vehicular and rapid transit traffic.

It is suggested that right-of-way be acquired for the combined west side superhighway and rapid transit railroad development one block in width through the entire improvement west of Racine Avenue with the exception of a short section between Paulina Street and Damen Avenue—see Sheet 43. Here it seems advisable to shift the improvement to the north—following the original plan—so as to avoid the modern building occupied by the Y. M. C. A. and the nurses' home.

The space between the south curb of the eastbound express roadway and the north (westbound) rapid transit railroad track is 111 feet east of Ashland Boulevard and 88 feet west of Damen Avenue. This provides ample space between these two facilities which, when suitably landscaped, would effectively screen the depressed rapid transit railroad from the highway so as to insure no interference of any character in the use of either of these facilities. Figure 21 shows a perspective of the alternate plan and gives an idea of the appearance of the proposed superhighway near a rapid transit station. Retaining walls would be utilized extensively

in the construction of the proposed ramps and service drives between Ogden Avenue and Paulina Street, but elsewhere the broad rights-of-way afford ample opportunity for the construction of these ramps with a minimum of exposed concrete.

Intersecting and Connecting Streets

A number of changes in the pattern of overpasses for cross streets are provided in the alternate plan. There is no change east of Halsted Street. West of Halsted Street, however, no cross connections are planned for Green Street, Sangamon Street or Aberdeen Street. The Racine Avenue, Morgan Street, Peoria Street and Halsted Street crossings would become overpasses rather than underpasses as in the original plan.

The alternate plan effects an improvement in the design of the intersecting roadway of Desplaines Street where the existing curb grade of approximately +14.0 can be maintained, as compared with the raised grade of +18.0 required by the subway connection between Desplaines Street and Halsted Street in the original plan.

One-way traffic control is contemplated on all of the adjacent service drives except on Van Buren Street east of Kedzie Avenue. The alternate plan differs from the original plan in that one-way traffic control along Congress Street would be extended from Ogden Avenue west to Sacramento Boulevard.

Estimates of Cost

While the considerably additional amount of private property to be acquired under the alternate plan—see Sheet 43—involves substantially increased costs, the reduction in height of retaining walls would offset this additional right-of-way cost to a degree. However, the cost of elevated railroad connections, the construction of the new rapid transit tracks at depressed grade, the new rapid transit stations and greater length of bridges, have the net effect of increasing the total cost of the project some \$7,120,000. The estimates include no allowance for the cost of the right-of-way owned by the Chicago Rapid Transit Company. An estimate of cost of the alternate plan summarized by sections between Desplaines Street and Kedzie Avenue is as follows:

ESTIMATE OF COST OF ALTERNATE PLAN			
WEST SIDE SUPERHIGHWAY AND RAPID TRANSIT TRACK DEPRESSION			
	<i>Land and Buildings</i>	<i>Construction</i>	<i>Total</i>
Michigan to Desplaines*	\$ 5,040,000	\$ 5,200,000	\$10,240,000
Desplaines to Throop	1,440,000	2,950,000	4,390,000
Throop to Ashland	610,000	1,650,000	2,260,000
Ashland to Damen	910,000	2,930,000	3,840,000
Damen to Western	910,000	1,800,000	2,710,000
Western to California	840,000	1,950,000	2,790,000
California to Kedzie	650,000	1,580,000	2,230,000
Kedzie to Austin*	5,530,000	4,980,000	10,510,000
Total	\$15,930,000	\$23,040,000	\$38,970,000

* No change from original plan

A comparison of the above alternate plan estimates with those of the original plans shows estimated cost of land and buildings to be increased from \$14,385,000 to \$15,930,000 — about 11 per cent — construction from \$17,080,000 to \$23,040,000 or 35 per cent — and the total cost of the entire project from \$31,465,000 to \$38,970,000 or 23 per cent. However, it removes more than three miles of elevated railroad structure and seven and one-half miles of elevated railroad track and provides three miles of additional subways for the west side including an express track for express service between Marshfield junction and Kedzie Avenue — all at an added cost of seven and one-half million dollars. This is *less than half* of the cost of constructing subways to provide equal rapid transit facilities.

ALTERNATE POLK STREET ROUTE FOR WEST SIDE SUPERHIGHWAY

Numerous suggestions and plans have been advanced from time to time for alternate routes for the west side superhighway. Of the suggested routes south of Madison Street a route along the general line of Polk Street has been mentioned more frequently than any other location except Congress Street.

With this in view, it seemed advisable to study an alternate layout along the line of Polk Street locating the downtown terminal either on Congress Street or on Polk Street. This has been done and the alternate route given for consideration is shown on Sheet 44. An examination of the area between Congress Street and Roosevelt Road developed the feasibility of a location in the vicinity of Polk Street west of the Chicago River except in the area between Hermitage and Damen Avenues now utilized as a medical center—see Figure 28. The partially completed plans for the complete development of this center contemplate the use of this entire district for hospitals, medical schools, convalescent parks and related purposes, making it expensive and highly undesirable to penetrate this district with any type of express thoroughfare. The location of the existing buildings alone is such as to involve an enormous increase in cost if an attempt were made to open a highway at any location between Congress Street and Taylor Street. For this reason the Polk Street alternate layout is diverted to a location south of Taylor Street between Wood Street and Damen Avenue just as the Congress Street route is diverted north to Van Buren Street at this location. This offset may be accomplished by means of easy curves with radii ranging from 1,000 to 1,600 feet.

Between Canal Street and Ashland Avenue the width of the right-of-way to be acquired varies in general from 150 feet to 350 feet. Between Ashland Avenue and Western Avenue the average width is about 250 feet and west of this point about 400 feet.

General Description of Improvement

The Polk Street alternate as studied would be in general similar to the superhighway proposed for the Congress Street location. The express roadways would be carried on an elevated structure east of Desplains Street descending to a depressed grade at Halsted Street and extending thence west to Columbus Park and

the city limits as a depressed roadway. The Polk Street line has an advantage in its freedom from complications due to the proximity of the elevated railroad structure, except in the section between Pulaski Road and Kostner Avenue. This affords an opportunity to plan a somewhat more liberal width of right-of-way through much of this improvement as compared with that proposed for Congress Street but a disadvantage from a traffic handling point of view because of its more southerly location.

The adoption of the Polk Street route would involve numerous difficult, if not impossible problems in the area east of Canal Street. Polk Street has a width of only 40 feet between Clark Street and the Chicago River so that extensive and costly widening would be required in this section. This would involve substantial damages to the warehouse buildings on the north side of the street between Canal Street and the river as well as various buildings between Wells Street and Clark Street. A photograph of Polk Street looking east from Jefferson Street is shown on Figure 22 and gives some idea of the buildings involved in widening Polk Street at this location. The structure between the Chicago River and La Salle Street would necessarily be elevated so as to pass over the tracks of the railroads leading to the Grand Central Station and the LaSalle Street Station. This would place the grade of the structure at LaSalle Street more than 40 feet above normal street grade. As a result of this, connections to the existing street system west of Dearborn Street would be virtually impossible. The ramp connecting this elevated structure with normal street grade in the center of Polk Street would terminate in the block between Dearborn Street and State Street so that there would be a ramp structure in the center of Polk Street opposite the Dearborn Street railroad station. Polk Street terminates at State Street so that costly opening or widening would be required to connect with Eighth Street east of State Street.

The planning of ramps and connecting roadways to provide efficient distribution of superhighway traffic from such an elevated structure to the existing street system presents an almost impossible problem. Ramps would be required for connections to Franklin, Wells, Sherman, LaSalle, Clark and Dearborn Streets. Such ramps would partially obstruct these north and south streets or require the acquisition of costly property to compensate for the space to be occupied by the ramps.

Study was also made of the practicability of constructing a tunnel under the Chicago River for superhighway traffic along the Polk Street alignment. This layout would provide for a connection between such tunnel and depressed roadways extending from Canal Street to Halsted Street in lieu of the elevated structure contemplated in the original Congress Street layout. Such a tunnel would extend from depressed highway grade at a point between Canal and Clinton Streets on the west of the river to a connection to normal street grade east of Clark Street. No practicable method of providing access from such tunnel to intersecting roadways of Canal, Franklin, Wells, Sherman and LaSalle Streets was found. However, by depressing the intersection of Clark Street and Polk Street about 8 feet, it would be possible to keep Clark Street open and to provide connection to the road-

ways both to the north and to the south of Polk Street. Not only would such a plan be inferior to the one suggested for the Congress Street location in many respects but also it would cost almost \$5,000,000 additional. In view of this and other disadvantages of the Polk Street terminal location it is suggested that no further consideration be given it is a terminal.

Therefore a study was made of the practicability of the utilization of the Congress Street route east of Canal Street with the Polk Street alternate alignment west of Halsted Street. This may be accomplished by planning the improvement on a reverse curve starting on the west line of Canal Street at Congress Street veering to the south and to the west in such a way as to connect with the Polk Street alignment at the east line of Halsted Street—see Sheet 44. A portion of this route would be through the vacant land between Jefferson Street and Desplaines Street and south of Harrison Street. West of Desplaines Street various school, church, industrial, commercial and residential lands and buildings would be taken for right-of-way—the number and cost being generally similar to that involved in the Congress Street location. Vernon Park and connecting parkways between Racine Avenue and Loomis Street would be displaced but in the estimate of cost, allowances are made for the acquisition of a nearby substitute tract of equal size.

Relative Efficiency of Polk Street Alternate

Comparison of this alignment with that proposed for Congress Street—see Sheet 44—shows the superiority of the Congress Street location. The offsets from Congress Street to Polk Street and from Polk Street to Taylor Street—while accomplished by easy curves result in additional length requiring adverse travel and loss of time for all motorists using the proposed thoroughfare. At the west end, the Polk Street terminal would connect admirably with the roadway proposed along the south margin of Columbus Park. It must be remembered, however, that a substantial portion of the traffic which will use the superhighway, originates to the north of this location and moving the thoroughfare to a location one-quarter of a mile further south would place it at a disadvantage with respect to attracting through traffic not only from Jackson and Washington Boulevards but also other thoroughfares to the north.

Delivery afforded vehicles to intermediate points between the city limits and the downtown district are less convenient than the Congress Street location. The Polk Street route is not conveniently located with respect to most of the important focal points on the west side. This route would be in competition with Roosevelt Road—less than one-eighth of a mile to the south—in the section south of the medical center.

Estimates of Cost

Estimates of cost of land and buildings and construction involved in the Polk Street alternate have been made in a manner similar to those utilized in making the Congress Street estimates. These figures are based on the use of the Congress Street terminal east of Canal Street. These estimates are summarized as follows:

ESTIMATES OF COST
WEST SIDE SUPERHIGHWAY—POLK STREET ALTERNATE

	<u>Land and Buildings</u>	<u>Construction</u>	<u>Total</u>
Michigan to Canal*	\$ 4,330,000	\$ 4,200,000	\$ 8,530,000
Canal to Racine	1,850,000	2,470,000	4,320,000
Racine to Ashland	520,000	990,000	1,510,000
Ashland to Damen	730,000	1,460,000	2,190,000
Damen to Western	570,000	1,390,000	1,960,000
Western to California	530,000	1,020,000	1,550,000
California to Kedzie	650,000	730,000	1,380,000
Kedzie to Central Park	880,000	690,000	1,570,000
Central Park to Pulaski	1,080,000	890,000	1,970,000
Pulaski to Kostner	890,000	690,000	1,580,000
Kostner to Cicero	840,000	860,000	1,700,000
Cicero to Laramie	400,000	650,000	1,050,000
Laramie to Central	400,000	730,000	1,130,000
Central to Austin		200,000	200,000
Total	\$13,670,000	\$16,970,000	\$30,640,000

* No change from west side superhighway estimate.

The total cost of a west side superhighway using the Polk Street alternate route west of Canal Street is \$30,640,000 or \$825,000 less than the estimated cost of the Congress Street project. Of this reduction, \$715,000 is the lower cost of right-of-way and \$110,000 reduced construction cost. The estimated saving of \$825,000, while substantial, may not be sufficient to compensate for the traffic advantages of the Congress Street location.

APPENDIX I

The Initial Use and the Capacity
of the
Proposed West Side Superhighway

APPENDIX I

THE INITIAL USE AND THE CAPACITY OF THE PROPOSED WEST SIDE SUPERHIGHWAY

PRESENT WEST SIDE TRAFFIC

This memorandum describes in some detail the several studies involved in estimating the initial use and capacity of the proposed Congress Street thoroughfare, together with summaries of data utilized.

Data on traffic on west side thoroughfares which will be benefited by the construction of a west side superhighway are available through traffic counts made by the State Division of Highways, the Chicago Park District, the Division of Traffic Engineering and the Committee on Local Transportation of the City of Chicago. The State counts include numerous 12-hour counts made in 1933 and subsequent years. The Committee counts were made in 1936 and 1937. The Park District counts, which were made in 1936 and 1937, were for 12 and 24-hour periods and also included continuous counts at certain intersections.

The Division of Traffic Engineering of the Department of Streets and Electricity, City of Chicago, has conducted periodical traffic checks at a large number of important street intersections throughout the urban area, starting in the year 1926. These checks have been made by a small skilled staff and have been taken at various seasons during the year. These counts cover the 16-hour period from 7:00 A. M. to 11:00 P. M.

This data, covering as it does the entire urban area and a period of more than 10 years, provides an exceptionally reliable factual basis for determining the increase in traffic volumes over the city street system. An analysis of these counts indicates that the average increase in traffic throughout the entire urban area has been at the rate of approximately 3.4 per cent per annum. This compares with an increase in ownership of motor vehicles, of approximately 5 per cent per annum. That the rate of increase of use of motor vehicles is only 78 per cent of the rate of increase of ownership is doubtless due to the fact that the development of the highway facilities in and near Chicago has not kept pace with automobile registration.

Data on traffic to the central business district was summarized in the 1937 Report on A Comprehensive Local Transportation Plan for the City of Chicago, as follows:

"During the last ten years cordon counts have been made to determine the volume and character of traffic to and from the central business district. These counts cover a twelve-hour period from 7:00 A. M. to 7:00 P. M. and represent a typical weekday for May. The number of all vehicles entering the central business district has increased 26.6 per cent from 132,913 in the year 1926 to 168,251 in 1937, or about 2.5 per cent per annum.

"It is significant that the average annual rate of increase for traffic entering the central business district is less than half the annual rate of increase in registration. This is largely the result of four factors:

1. The actual area of the so-called central business district is larger than the area within the cordon count boundaries and therefore the cordon counts can not accurately reflect the activities of the true central business area;
2. Inadequate highway facilities in and leading to the central business district;
3. The cost of parking cars within this district; and
4. The increasing development of commercial, industrial and recreational centers elsewhere throughout the corporate area of Chicago."

The Division of Traffic Engineering also carried on comprehensive volume counts of both vehicular and pedestrian traffic during the period February 26, 1938 and April 22, 1939 with personnel provided by the Works Progress Administration. These were more comprehensive and more recent than counts completed by any other agency and were therefore utilized throughout this study as a basis for estimating traffic volumes.

Hourly, Daily and Monthly Variations in Traffic

The test of the capacity of any transit facility occurs during the peak periods of the morning and evening rush hours. Certain of the data on traffic volumes available for this study was in the form of 12, 16 or 24-hour count totals. Therefore, the data available through the continuous counts made by the Chicago Park District for a 12-month period during 1936 and 1937 were invaluable as a basis for estimating peak period volumes. Three continuous count stations were maintained—

At Michigan Avenue and Monroe Street,
At Sacramento, Washington and Warren Boulevards, and
At Jackson and Ashland Boulevards.

These continuous counts have been summarized in Tables 1, 2 and 3. These tables show maximum week-day 30-minute traffic volumes, 12 and 24-hour totals, and percentages of maximum 30-minute to 12 and 24-hour totals and resultant averages. These percentages have been used in estimating maximum 30-minute traffic volumes at locations on various west side thoroughfares from which traffic will be diverted to the proposed superhighway system.

TABLE 1
SUMMARY OF CONTINUOUS COUNTS MADE BY CHICAGO PARK DISTRICT—1936-1937
AT MICHIGAN AVENUE AND MONROE STREET

Date of Count	MAXIMUM 1/2 Hour					TOTALS 12 Hours			TOTALS 24 Hours			PERCENTAGES to 24 Hours					Average 1/2 Hour to 24 Hours	
	2	3	4	5	6	7	8	9	10	11	Inbound		Outbound		12-14	15-15		
	East	West	North	South	E-W*	N-S	Total	E-W*	N-S	Total	2/9	4/10	3/9	5/10	E-W*	N-S		
Thur. 4-23-36	252	703	1,092	1,466	13,740	40,736	51,476	19,250	57,252	76,502	1.31	1.91	3.66	2.56	2.19	2.23		
Mon. 5-11-36	193	569	948	1,388	12,012	42,416	51,488	16,699	58,261	74,960	1.15	1.63	3.40	2.38	2.27	2.01		
Tue. 6-16-36	231	716	1,041	1,409	13,173	39,665	51,838	21,886	56,655	78,541	1.15	1.81	3.40	2.49	2.27	2.16		
Wed. 7-8-36	215	876	1,091	1,417	14,529	41,975	56,501	23,299	65,823	89,122	0.92	2.27	3.76	2.15	2.31	2.21		
Mon. 8-21-36	250	791	1,483	1,883	15,127	41,140	56,567	21,461	58,839	80,303	1.16	1.11	3.70	2.52	2.43	1.97		
Mon. 11-23-36	216	611	947	1,503	14,348	43,081	57,432	19,995	59,525	79,520	1.13	1.62	3.43	2.43	2.28	2.02		
Tue. 12-29-36	251	630	901	1,302	13,182	42,132	53,314	17,872	58,227	76,099	1.21	1.63	3.60	2.58	2.41	2.11		
Wed. 1-6-37	226	608	924	1,413	12,606	41,187	55,151	18,657	57,282	75,939	1.35	1.57	3.38	2.28	2.36	1.93		
Fri. 2-12-37	202	732	815	1,294	14,324	40,576	51,900	17,020	57,539	74,359	1.33	1.60	3.57	2.51	2.45	2.05		
Mon. 3-13-37	221	665	861	1,337	13,347	40,461	53,811	17,525	56,803	76,528	1.02	1.44	3.71	2.27	2.37	1.86		
Average 11 Months	228	696	984	1,417	13,853	41,491	55,241	19,399	58,271	77,670	1.18	1.68	3.58	2.44	2.38	2.06		

TABLE 2
SUMMARY OF CONTINUOUS COUNTS MADE BY CHICAGO PARK DISTRICT—1936-1937
AT SACRAMENTO, WASHINGTON, AND WARREN BOULEVARDS*

Date of Count	MAXIMUM 1/2 Hour						TOTALS			PERCENTAGES								
	Inbound			Outbound			12 Hours			24 Hours			Maximum 1/2 Hour to 24 Hours			Averages Max. 1/2 Hour to 24 Hours		
	2	3	4	5	6	7	8	9	10	11	12	13	14	15	16	17	18	19
Mon. 4-6-36	1,496	418	1,448	380	27,761	8,660	36,121	37,697	11,481	49,178	3,97	3.64	3.84	3.31	3.90	3.48	3.64	3.37
Fri. 5-15-36	1,618	405	1,420	345	28,815	7,712	36,525	41,830	11,131	52,961	3.87	3.64	3.40	3.10	3.64	3.37	3.40	3.13
Tue. 9-1-36	1,383	500	1,219	386	27,333	10,231	37,564	38,245	14,165	52,410	3.62	3.55	3.19	2.73	3.40	3.13	3.40	3.13
Tue. 11-24-36	1,359	561	1,299	436	26,788	10,089	36,877	37,587	13,778	51,365	3.62	4.07	3.46	3.17	3.54	3.62	3.40	3.13
Fri. 12-11-36	1,366	509	1,499	451	26,695	10,051	36,746	38,045	13,893	51,908	3.59	3.64	3.95	3.25	3.77	3.44	3.40	3.13
Fri. 1-8-37	1,343	566	1,380	469	25,419	10,754	36,173	35,086	14,400	49,486	3.83	3.93	3.95	3.26	3.89	3.60	3.40	3.13
Wed. 2-3-37	1,262	535	1,447	492	25,675	10,593	36,268	35,709	14,252	49,961	3.56	3.75	4.05	3.46	3.80	3.61	3.40	3.13
Tue. 3-9-37	1,291	605	1,436	561	25,934	11,236	37,170	35,003	14,933	49,936	3.69	4.05	4.16	3.75	3.92	3.90	3.40	3.13
Average 8																		
Months	1,389	512	1,396	440	26,802	9,918	36,720	37,396	13,504	50,901	3.72	3.79	3.72	3.26	3.73	3.52	3.40	3.13

* During months of June, July and August, 1936, counts were suspended during pavement repairs.

TABLE 3
 SUMMARY OF CONTINUOUS COUNTS MADE BY CHICAGO PARK DISTRICT—1936-1937
 AT JACKSON AND ASHLAND BOULEVARDS

Date of Count	MAXIMUM 1/2 HOUR										PERCENTAGES																			
	Inbound					Outbound					TOTALS					Maximum 1/2 Hour to 24 Hours					Average Max. 1/2 Hour to 24 Hours									
	1	2	3	4	5	6	7	8	9	10	11	12	13	14	15	16	17	18	19	20	21	22	23	24	25	26	27	28	29	30
Wed. 4-15-36	669	362	658	452	15,536	12,540	28,076	20,759	16,305	37,061	16,305	37,061	3.22	2.22	3.17	2.77	3.20	2.50	3.11	1.89	3.11	2.50	3.11	2.20	2.28	2.28	2.28	2.28	2.28	2.28
Thur. 5-21-36	711	330	712	437	16,831	12,806	29,637	22,918	17,481	40,399	17,481	40,399	3.11	2.01	3.15	2.53	3.07	2.28	2.99	2.01	3.15	2.53	3.07	2.28	2.28	2.28	2.28	2.28	2.28	2.28
Wed. 6-10-36	671	354	709	439	16,560	13,056	29,616	22,502	17,377	39,879	17,377	39,879	2.90	1.78	3.21	3.01	3.06	2.40	2.90	1.78	3.21	3.01	3.06	2.40	2.40	2.40	2.40	2.40	2.40	2.40
Thur. 7- 9-36	689	311	707	526	15,600	12,680	28,280	22,003	17,490	39,493	17,490	39,493	3.27	1.99	4.02	2.73	3.66	2.36	3.27	1.99	4.02	2.73	3.66	2.36	2.36	2.36	2.36	2.36	2.36	2.36
Fri. 8-14-36	701	359	862	493	15,581	13,156	28,740	21,432	18,050	39,482	18,050	39,482	4.25	3.37	3.05	2.82	3.21	2.40	4.25	3.37	3.05	2.82	3.21	2.40	2.40	2.40	2.40	2.40	2.40	2.40
Tue. 9-13-36	831	350	755	502	18,613	13,352	31,965	21,745	17,802	42,547	17,802	42,547	3.13	2.33	3.22	2.57	3.32	2.35	3.13	2.33	3.22	2.57	3.32	2.35	2.35	2.35	2.35	2.35	2.35	2.35
Mon. 11-23-36	750	382	705	421	17,156	13,307	30,463	21,827	16,398	38,225	16,398	38,225	3.28	2.00	3.23	2.17	3.26	2.24	3.28	2.00	3.23	2.17	3.26	2.24	2.24	2.24	2.24	2.24	2.24	2.24
Thur. 12-10-36	731	362	721	446	16,693	13,761	30,454	22,345	18,070	40,415	18,070	40,415	2.55	1.94	2.29	2.23	2.12	2.08	2.55	1.94	2.29	2.23	2.12	2.08	2.08	2.08	2.08	2.08	2.08	2.08
Sat. 1- 9-37	605	369	511	423	17,171	13,666	30,837	23,740	19,010	42,750	19,010	42,750	4.23	2.09	3.32	2.81	3.28	2.45	4.23	2.09	3.32	2.81	3.28	2.45	2.45	2.45	2.45	2.45	2.45	2.45
Wed. 2- 3-37	677	330	698	444	16,131	12,590	28,721	21,068	15,838	36,906	15,838	36,906	3.21	2.30	3.26	2.75	3.23	2.52	3.21	2.30	3.26	2.75	3.23	2.52	2.52	2.52	2.52	2.52	2.52	2.52
Tue. 3-16-37	696	301	709	468	16,379	12,912	29,291	21,731	17,044	38,778	17,044	38,778	3.14	2.05	3.18	2.65	3.16	2.35	3.14	2.05	3.18	2.65	3.16	2.35	2.35	2.35	2.35	2.35	2.35	2.35
Average 11 Months	698	355	707	459	16,569	13,075	29,640	22,270	17,351	39,631	17,351	39,631																		

Half hour variations in traffic based on averages of five week-day counts during January, July and May have been plotted on Figure 23. The sharp peak during the morning rush hour is clearly brought out and indicates the advisability of basing capacity studies on maximum 30-minute periods.

Daily variations in traffic during typical winter and summer weeks are shown on Figure 24. The uniformity of traffic volumes on the six week-days is brought out by this chart, as is the rather remarkable decrease in traffic on Sundays. The soundness of basing superhighway design on week-day traffic counts is conclusive, in the absence of heavy week-end volumes.

Figure 25 shows available data from the three continuous count stations in monthly variations in total 24-hour week-day traffic. These charts show the very interesting uniformity of traffic volumes throughout the calendar year.

The maximum variation from average traffic volumes noted was only 13 per cent and the minimum varied from the average less than 7 per cent.

Traffic Volumes

Estimates were made from all of the data studied of average week-day inbound passenger vehicle movements* on major thoroughfares between the west side and the central business district during the maximum 30-minute period. These estimates have been summarized and are charted on Figure 17. No attempt has been made to indicate the flow of traffic on local streets such as Taylor, Polk, Fulton or Erie Streets as for various reasons these and the other streets not shown are of no importance as thoroughfares for traffic to and from the central business district.

The following thoroughfares** are now available to serve east and west traffic between the central business district and the west city limits:

Chicago Avenue	Monroe Street
Huron Street	Adams Street
Erie Street	Jackson Boulevard
Hubbard Street	Van Buren Street
Kinzie Street	Harrison Street
Fulton Street	Lexington Street
Lake Street	Polk Street
Randolph Street	Arthington Street
Washington-Warren Boulevard	Taylor Street
Madison Street	Roosevelt Road

Of these only the following afford continuous travel to the western city limits:

Chicago Avenue	Jackson Boulevard
Lake Street	Harrison Street
Washington-Warren Boulevard	Roosevelt Road
Madison Street	

* Street cars and buses excluded.

** Streets with maximum continuous section of less than 2 miles omitted. Grand Avenue and Ogden Avenue diagonals not directly serving the central business district, also omitted.

Chicago Avenue, Lake Street, Madison Street, Harrison Street and Roosevelt Road are street car routes—the two center lanes being largely given over to street car traffic. The roadway of Lake Street is obstructed by elevated railroad structure columns for much of its length. With the exception of Roosevelt Road, the boulevards and short sections of the other thoroughfares, roadways are narrow and partially obstructed by parking; with the result that the major portion of the east and west traffic burden is carried by Washington (Warren) Boulevard, Jackson Boulevard and Roosevelt Road. This condition is shown clearly on the flow chart showing existing inbound traffic during the maximum 30-minute period—see Figure 17.

The beneficial effect of the one-way street operation afforded by the Washington-Warren artery between Garfield Park and Ogden Avenue is apparent from the following tabulation showing distribution of the total eastbound passenger vehicle traffic at 3 locations between Western Avenue and Canal Street:

INBOUND PASSENGER VEHICLE TRAFFIC
MAXIMUM 30-MINUTE PERIOD
Typical Week-Day—1938-1939

<i>Thoroughfare</i>	EAST LINE OF WESTERN AVENUE		WEST LINE OF ASHLAND AVENUE		EAST LINE OF CANAL STREET	
	<i>Vehicles</i>	<i>Per Cent</i>	<i>Vehicles</i>	<i>Per Cent</i>	<i>Vehicles</i>	<i>Per Cent</i>
Warren Boulevard	1,882	54	1,329	37	653	24
Jackson Boulevard	739	20	728	21	418	16
Roosevelt Road	425	11	733	21	480	18
Other Streets—						
Chicago Avenue to Roosevelt Road	556	15	726	21	1,112	42
Total	3,602	100	3,516	100	2,663	100

Inbound traffic in the central business district during the maximum 30-minute period based on typical week-day counts made during 1938-39 is shown on Figure 19. This chart shows inbound passenger vehicles eastbound to Michigan Avenue, northbound and southbound from Congress Street. It is noted that there is a tendency for this passenger vehicle traffic to equalize on the roadways of the several streets in this highly congested area. The heavy use of the existing distributor streets—Wacker Drive and Michigan Avenue—is also evident.

The inefficient use of most of the roadways in the loop district is apparent from an examination of this flow chart. The total eastbound traffic on the several loop streets at the west line of Clark Street, the width of the roadway of each and the percentage use, taking present use of the Jackson Street roadway at 100 per cent, is shown on the following tabulation:

<i>Street</i>	<i>Roadway Width in Feet</i>	<i>Eastbound Passenger Vehicles Maximum 30 Minutes</i>	<i>Per Cent of Use</i>
Harrison Street	51	188	66
Van Buren Street	38	110	39
Jackson Street	38	284	100
Adams Street	38	73	26
Monroe Street	38	121	43
Madison Street	44	63	22
Washington Street	48	159	56
Randolph Street	48	195	69
Lake Street	48	95	34
Average	43	143	51

Much of this inefficient distribution of traffic may be attributed to intensive use of most of these thoroughfares for downtown terminal movements of west side street car lines. The removal of trolley car operation from east and west streets, as proposed in the foregoing report on the extension of the subway system, will permit the more efficient use of these streets, thereby providing a substantial increase in capacity to accommodate any prospective increases in passenger automobile traffic which will result from the construction of the west side and other superhighways.

Origin and Destination

The results of origin and destination counts of traffic using state highways within the Chicago metropolitan district during the period August 1, 1931 to Labor Day, made by the State Division of Highways, were published in a "Report on the Survey of Traffic on Illinois State Highways." The following tabulation abstracted from that report shows the percentage of traffic passing Harlem Avenue which had a destination east of Halsted Street:

<i>Thoroughfare</i>	<i>Per Cent of Traffic With Destination East of Halsted Street</i>
North Avenue	19.9
Lake Street	23.1
Washington Boulevard	44.6
Roosevelt Road	22.3
Archer Avenue	6.0
Milwaukee Avenue and Northwest Highway	16.8*

* Counts made at City Limits.

The staff of the Committee on Local Transportation made a count of eastbound vehicles with and without city license tags using Madison Street and Washington Boulevard with a view to securing a further basis for estimating probable use of the proposed west side superhighway. This count was made from 7:00 A. M. to 1:00 P. M. on November 19, 1937 with the results appearing in the following tabulation:

COUNTS OF VEHICLES WITH AND WITHOUT CITY LICENSE TAGS
Eastbound Traffic—7:00 A. M.—1:00 P. M.

	AT CIGERO AVENUE			AT ASHLAND AVENUE		Per Cent (5) of (2)
	Total (1)	FOREIGN VEHICLES		Total (4)	Foreign Vehicles Number (5)	
		Number (2)	Per Cent (3)			
Washington-Warren Boulevards	4,768	2,663	56	8,770	2,484	93
Madison Street	2,874	1,425	50	1,131	246	17
Total	7,642	4,088	53.5	9,901	2,730	67

Speeds

During January and February of 1934, a check of the average speed of passenger automobiles was made by the State Division of Highways on a number of the principal arteries on the west side. The following table shows the average speed reported for the various routes checked:

<u>Thoroughfare</u>	<u>From</u>	<u>To</u>	<u>M.P.H.</u> <u>Outbound</u>	<u>M.P.H.</u> <u>Inbound</u>
Cermak Road	Canal Street	Austin Boulevard	16.6	19.0
Roosevelt Road	Canal Street	Austin Boulevard	18.3	18.3
Jackson Boulevard	Canal Street	Austin Boulevard	19.9	20.8
Washington-Warren Boulevards	Canal Street	Austin Boulevard	19.7	20.8

In November and December of 1937, test runs in private automobiles were made by the staff of the Committee on Local Transportation on thoroughfares tabulated below. Test runs were made during rush and non-rush periods and the average speeds developed are shown in the following table:

<u>Thoroughfare</u>	<u>From</u>	<u>To</u>	<u>M.P.H.</u>	
			<u>Rush Hour</u>	<u>Non-Rush Hour</u>
Ogden Avenue	Cermak Road	Wood Street	13.8	16.8
Washington-Warren Boulevards	Austin Boulevard	Paulina Street	16.6	20.4

Test runs in private automobiles were also made by the Traffic Engineering Section of the Chicago Park District and resultant average speeds are shown in the following table:

<u>Thoroughfare</u>	<u>From</u>	<u>To</u>	<u>M.P.H.</u>	
			<u>Out- bound</u>	<u>In- bound</u>
Augusta Boulevard	Austin Boulevard	Elston Avenue	28—	22+
Washington Boulevard	Oakley Boulevard	Michigan Avenue	12+	13+
Jackson Boulevard	Damen Avenue	Michigan Avenue	14	15—
Austin Boulevard	North Avenue	Roosevelt Road	20+	26—
Roosevelt Road	Canal Street	Pulaski Road	16+	15
Ashland Avenue	Roosevelt Road	North Avenue	14+	15—
North Avenue	Elston Avenue	Austin Boulevard	19+	19—
Pulaski Road	Ogden Avenue	North Avenue	16—	15—
Madison Street	Canal Street	Austin Boulevard	12—	16+

DATA ON ROADWAY CAPACITY

A study of useful and convenient capacity of traffic lanes on major thoroughfares as well as speeds thereon, is essential to an estimate of the probable use and capacity of the proposed west side superhighway. Detailed studies of traffic movements at and near intersections are also required to appraise the effect of exit and entrance ramps. There has been a great deal of technical discussion relative to traffic control published during the past few years from which certain data applicable to the study at hand has been abstracted as a basis for the consideration of this special problem.

Speeds—Various Data

In a paper on "A Study of Traffic Capacity" by Bruce D. Greenshields, Research Engineer of the Ohio State Highway Department, the results of speed observations on a number of state highways in Ohio are presented. These studies are summarized in Table 4.

TABLE 4
SPEEDS—AVERAGE DATA FOR UNCONGESTED ROADS

<i>Route</i>	<i>Density in Vehicles per Hour</i>	<i>Number of 100-Vehicle Groups Observed</i>	<i>Mean Smoothed Speed M. P. H.</i>	<i>Percentage of Trucks</i>	<i>Percentage Traveling in One Direction</i>
U. S. 6. 4.9 Miles East of Vermilion					
Friday, 8-17-34	379	68	42.4	7.5	54.4
Sunday, 9-2-34	654	99	38.8	0.8	56.8
Wednesday, 8-29-34	267	69	45.3	7.7	64.4
U. S. 20. 2.0 Miles West of Oberlin	277	30	43.3	6.9	41.5
U. S. 20. 1.4 Miles West of Monroeville	593	109	44.2	3.7	50.4
U. S. 20. 1.5 Miles West of Bellevue	336	59	42.8	7.5	56.0
U. S. 20. 0.25 Miles West of Oberlin	382	27	37.1	6.8	38.5
U. S. 20. 1.8 Miles East of Perrysburg	134	72	37.0	6.7	39.8
U. S. 20. 2.4 Miles East of Oberlin	360	13	42.9	2.2	49.8
U. S. 6—30' new pavement—straight—unobstructed view—ideal for high speed traffic.					
Others—Brick—aspalt—macadam—concrete—18' to 22' wide—all fair con- dition—some with deep ditches and narrow shoulders.					

Mr. Greenshields concluded as follows:

"It may be concluded from the study of 1,180 groups of 100 vehicles each, taken from over 22,000 vehicles observed, that the average free moving speed of vehicles on a first class roadway in dry weather with the percentage of trucks varying from zero to ten is very nearly constant and equal to approximately 43 miles per hour. This speed holds for either a two or three lane highway. The bumps per mile on one location were twelve and on another 492, showing that a certain amount of roughness has little effect on the speed. Passenger speeds of over 80 miles per hour and truck speeds of 60 miles per hour were recorded.

"The average free speed of 18 buses observed was 41.6 miles per hour."

Data on speeds of vehicles on city streets is contained in a paper on "Use and Capacity of City Streets", Transactions A. S. C. E. Vol. 99 (1934) by Hawley S. Simpson, Research Engineer, American Transit Association, New York, N. Y. The following tabulation based on surveys by the Detroit Rapid Transit Commission is abstracted from that paper:

TABLE 5
AVERAGE AND MAXIMUM MOTOR VEHICLE SPEEDS
DETROIT, MICHIGAN

<i>Street</i>	<i>Distance in Miles</i>	<i>Time Required in Minutes</i>	<i>Speed in Miles per Hour Average Including Effect of Delays</i>	<i>Number of Stops</i>	<i>Maximum Speed Between Stops in Miles per Hour</i>
Woodward Avenue	5.0	25	12.0	27	27
Gratiot Avenue	5.0	29	10.3	34	30
Grand River Avenue	5.0	28	10.7	33	25
Woodward Avenue	12.7	46	16.5	35	43
Gratiot Avenue	12.5	47	15.9	39	35
Grand River Avenue	12.6	50	15.0	41	35

Observations were made by the State Wide Highway Planning Survey of the State Division of Highways during the summer of 1937 to determine average speeds on free running sections of various highways in the Chicago metropolitan district. In all cases, observations were taken during normal summer week-days at times when traffic densities were comparatively light and the interferences to free flow of traffic at normal speeds resulting from traffic congestion were a minimum. Observations were taken covering standard two-lane and four-lane roadways and also a four-lane roadway divided by a broad center parkway. All pavements were built of concrete in first class condition with lane widths of at least 10 feet. The results of these observations are summarized in the following tabulation. The

summary shows the average speed of all cars observed and also the speed of the largest group of cars traveling at the several M. P. H. speeds observed.

TABLE 6
AVERAGE MOTOR VEHICLE SPEEDS—
STATE WIDE HIGHWAY PLANNING SURVEY

<i>Highway</i>	<i>Location</i>	<i>Direction</i>	<i>Time</i>	SPEEDS	
				<i>Average</i>	<i>Highest Group</i>
Cicero Avenue (2-Lane)	81st Street	N. B.	A. M.	33.9	33
		S. B.	A. M.	37.6	40
		N. B.	P. M.	33.4	33
		S. B.	P. M.	36.1	33
		Average			35.3
Cicero Avenue (4-Lane)	75th Street	S. B.	A. M.	40.9	48
		N. B.	A. M.	38.8	45
		S. B.	P. M.	—	42
		N. B.	P. M.	—	45
		Average			39.9
Skokie Highway in Lake County (Two 2-lane road- ways with broad center parkway)	West of North Chicago	N. B.	A. M.	46.6	48
		S. B.	A. M.	49.2	51
		N. B.	P. M.	46.0	46
		S. B.	P. M.	46.0	46
		Average			47.0

Data on Capacity and Use

Mr. Simpson's paper also contains useful information on street capacity and use—abstracted as follows:

"The results of representative surveys appear in Table 7 for which the following authorities may be recorded: Item No. 1, by A. N. Johnson, M. Am. Soc. C. E.; Items Nos. 2 and 3, by the American Transit Association; Item No. 4, by the Highway Research Board, Committee on Highway Traffic Analysis; Item No. 5, by the Cleveland Railway Company; Item No. 6, by the Detroit, Michigan, Rapid Transit Commission; Item No. 7, by Ole Singstad, M. Am. Soc. C. E.; Item No. 8, by E. A. Byrne, M. Am. Soc. C. E.; and, Item No. 9, by Day and Zimmerman, Inc. Referring to Item No. 7, the capacity of the Holland Tunnel is computed by the Engineers of the Port of New York Authority as 1,270 vehicles per hour per lane, in two lanes, when most of the traffic is composed of passenger vehicles. M. O. Eldridge, Assoc. M. Am. Soc. C. E., has stated that delays incident to the purchase

and collection of tickets, the weaving of vehicles from several lanes into two at the tunnel entrances, and the grades within the tunnel limit the capacity of the tubes."

TABLE 7
MAXIMUM OBSERVED RATES OF TRAFFIC FLOW
PER AVERAGE LANE — ONE DIRECTION

Item No. (1)	Location (2)	Number of Lanes in Each Direction (3)	MAXIMUM HOURLY RATES					
			20 sec. (4)	1 min. (5)	5 min. (6)	10 min. (7)	30 min. (8)	60 min. (9)
1	Baltimore-Washington Highway	1			1.968			1.502
	Lake Shore Drive Chicago, Illinois:							
2	Average for Both Lanes	2	2.070	1.830		1.392	1.365	1.349
3	Inner Lane	2	2.520	2.160		1.542	1.412	1.395
	Superior-Detroit High Level Bridge, Cleveland, Ohio:							
4	1928	3						1.241
5	1927	2½*			1.958	1.874	1.699	1.557
6	East Grand Boulevard, Detroit, Michigan	1		1.800		1.404	1.200	
	New York, N. Y.:							
7	Holland Tunnel	2						1.253
8	Queensborough Bridge	3						1.482
9	Manhattan Bridge	2						1.300

* Estimated number of effective lanes.

Mr. Simpson concludes from his studies of lane capacity: "A rate of flow for short periods as high as the probable ultimate will occur when the hourly traffic is about 1,800 vehicles per lane. The acceptance of such a figure for working purposes would leave only a small factor of safety, however. For present purposes a value of 1,500 vehicles per single lane per hour may be adopted as representing 'capacity', with the realization that higher flows are possible and in the belief that the factor of safety allowed is no greater than is necessary to maintain reasonably fluid movement at speeds consistent with safety and efficiency."

The results of observations of traffic flow in the curb lane and maximum hourly traffic per lane at Detroit are summarized in Mr. Simpson's paper as shown in Tables 8 and 9.

TABLE 8
 USAGE OF CURB LANE DURING MAXIMUM HOUR
 IN DETROIT, MICHIGAN (PARKING PROHIBITED)

<i>Item No. (1)</i>	<i>Location (2)</i>	<i>Number of One-Way Free Lanes (3)</i>	<i>Vehicles per Hour in Curb Lane Parking Prohibited (4)</i>	<i>Curb Lane Vehicles as Percentage of Average of Average Vehicles per Lane in Adjacent Lanes (5)</i>
1	John R. Street, at East Grand Boulevard	2	384	70
2	West Grand Boulevard, at 14th Street	3	295	40
3	West Grand Boulevard, at Cass Avenue	4	543	106
4	Grand River Avenue, at West Grand Boulevard	3	830	93
5	Jefferson Avenue, at East Grand Boulevard	4	707	78

TABLE 9
 MAXIMUM HOURLY MOTOR VEHICLE TRAFFIC
 PER LANE, DETROIT, MICHIGAN

<i>Location and Nature of Traffic</i>	<i>One-Way Roadway Width in Feet</i>	<i>Lane Number</i>	<i>Hourly Traffic</i>
Grand River Avenue, at West Grand Boulevard (automobiles, street cars, and buses; parking prohibited)	36	1 (curb)	830
		2	890
		3 (street car)	634*
Jefferson Avenue, at East Grand Boulevard (automobiles, street cars, and buses; parking prohibited)	45	1 (curb)	707
		2	895
		3	919
		4 (street car)	25†

* Also, 51 street cars, total vehicles in lane, 685.

† Private motor traffic prohibited on street car lane, used by express street cars and local motor buses. Total vehicles in lane, 91, consisting of 41 street cars, 25 buses, and 25 private automobiles.

An important contribution to traffic engineering was recently made by Mr. Lewis W. McIntyre of Pittsburgh in a paper on "Causes of Failure in Handling Traffic" published in the Proceedings of the A. S. C. E.—Volume 63 (November, 1937), from which the following is abstracted:

"Further light on the accuracy of Figure 1 was obtained from studies of the vehicle flow on the Wilmot Street Bridge, in Pittsburgh. This is a two-lane bridge—one lane in each direction. It has a large reservoir at one end for entering vehicles to accumulate, and at the other end for leaving vehicles to spread out promptly, so as not to delay those on the single lane of movement on the bridge. Table 10 shows an average rate of 1,710 vehicles per hour at a speed of 20 miles per hour, which rate was sustained over a period of 5 minutes at a time. A rate of 1,680 vehicles per hour was sustained for as long as 25 minutes." This data is summarized as follows:

TABLE 10
VEHICLE FLOW ON WILMOT STREET BRIDGE
PITTSBURGH, PENNSYLVANIA (ONE LANE)

<i>Date (1933)</i>	<i>Number of Vehicles in 25 Minutes</i>	<i>Number of Vehicles in a Maximum 5 Minutes</i>	<i>Rate of Flow in Vehicles per Hour</i>	<i>Speed in Miles per Hour</i>
October 5	701	145	1,740	20
October 6	619	142	1,680	20
Average	660	143.5	1,710	20

Table 11 shows counts of traffic volumes and hourly rate per lane for several typical congested Pittsburgh streets, as reported by Mr. McIntyre.

TABLE 11
TRAFFIC VOLUME PER LANE, TYPICAL PITTSBURGH INTERSECTIONS

<i>Street</i>	<i>At</i>	<i>Traffic From</i>	<i>Volume Maximum in 15 Minutes</i>	<i>Number of Lanes</i>	<i>Traffic per Lane</i>	<i>Hourly Rate per Lane</i>	<i>Remarks</i>
Fifth Avenue	Smithfield Street	East	124	2	62	248	Street Cars
Fifth Avenue	Smithfield Street	West	195	2	98	392	Street Cars
Ninth Street	Liberty Street	North	173	2	86	346	Street Cars
Sixth Avenue	Grant Street	East	261	2	130	520	Street Cars
Sixth Street	Penn Avenue	North	135	2	67	270	Street Cars
Allies *	Grant Street	East	577	2	188	754	No Street Cars
Allies *	Grant Street	West	505	5	102	408	No Street Cars
Grant Street	Allies *	North	217	3	72	288	Street Cars
Grant Street	Allies *	South	169	3	56	224	Street Cars
Grant Street	Seventh Street	North	207	3	69	276	No Street Cars
Grant Street	Seventh Street	South	252	3	84	336	Street Cars
Seventh Avenue	Grant Street	East	233	3	78	312	No Street Cars
Seventh Avenue	Grant Street	West	241	5	80	320	Street Cars
Fourth Avenue	Smithfield Street	West	100	3	33	132	One-Way †
Smithfield Street	Water Street	South	254	2	127	508	Bridge
Penn Avenue	Sixth Street	East	185	4	46	185	One-Way
Smithfield Street	Fourth Avenue	South	196	4	49	196	One-Way
Smithfield Street	Fifth Avenue	South	205	4	51	205	One-Way

* Boulevard of the Allies.

† Three Lanes.

A recent report covering street traffic in the City of Detroit—1936-1937, contains the following pertinent information on lane performance at a point of congestion:

“Investigations at the intersection of Woodward and Grand Boulevard reveal that traffic moving northward on Woodward Avenue during the evening rush hour is considerably delayed but that, in spite of the delay, the lanes for northbound traffic have a very high utility. The lane situated on the street car track carried 48 vehicles in the maximum five minute interval, 118 vehicles in the maximum fifteen minute period, and 212 vehicles in the maximum thirty minute period. These movements are at the respective rates of 576, 472 and 424 vehicles per hour. The vehicular traffic in this lane is of course interfered with by the movements of street cars, operating on approximately one and one-half minute headways. The lane adjacent to the street car track carried volumes during the maximum five minute period of 55 vehicles, during the maximum fifteen minute period, 161 vehicles, and during the maximum half hour period, 310 vehicles; these movements were at the rate of 660, 644 and 620 vehicles per hour, respectively. The lane adjacent to the parking lane carried vehicles at rates of 636, 604 and 596 vehicles per hour based upon volumes during the maximum five, fifteen, and thirty minute periods. During the observation, the lane adjacent to the curb was occupied by only one illegally parked car in the entire block south of the Boulevard, but this reduced the capacity of the lane to 12, 8, and 6 vehicles per hour, likewise based upon volumes during the five, fifteen, and thirty minute maximum periods.

“During all of these observations a condition of congestion existed. Each unit of traffic on Woodward was subjected to numerous stops before reaching the Boulevard and lines of vehicles were observed standing back of the intersection for distances ranging from two to four blocks, at times reaching as far south as Piquette. In this particular instance, congestion was caused by both the interference of a traffic signal at the Boulevard, so timed that traffic on Woodward was permitted to move through the intersection during only 40 per cent of the signal cycle, and by a reduction in the width of the pavement on Woodward, resulting in the reduction in the number of lanes available to the large volumes of traffic approaching the Boulevard from the south.”

Numerous traffic counts have been made on thoroughfares in various locations within the metropolitan district of Chicago which provide a basis for estimating probable useful capacity of superhighways. The following table shows maximum observed rates of traffic flow in one direction for various thoroughfares within the metropolitan area:

TABLE 12
MAXIMUM TRAFFIC VOLUMES IN CHICAGO

Location	Date	Direction	Roadway Width	Number of Lanes in Direction of Heavy Traffic	TRAFFIC MAXIMUM 30 MINUTES	
					Total	Per Lane
Foster Avenue and Sheridan Road	9-14-36	E. B.	48'	4 [*]	1,803	451
Michigan Avenue Bridge	11- 6-36	N. B.	54.5'	3	1,375	458
LaSalle Street and North Avenue	9-11-36	S. B.	74'	3	1,199	400
Warren Blvd. and Oakley Blvd.	6-14-38	E. B.	50'	5**	1,882	376
Jackson Blvd. and Ashland Blvd	9-15-36	W. B.	48'	2***	862	431

* Only 2 lanes available at west line of Sheridan Road.

** One way street.

*** Roadway at intersection marked so as to provide 3 lanes approximately 8 feet in width.

The count for Foster Avenue and Sheridan Road as indicated above was made from 8:15 to 8:45 A. M. at the west line of Sheridan Road and shows 1,803 private cars and taxis flowing eastbound on the four lanes available for eastbound traffic during the morning rush period. At the east line of Sheridan Road, all of this eastbound traffic is forced to flow through two lanes. There were no traffic lights or other interferences at this intersection.* This indicates that a total flow of traffic in a single lane free of control delays and other interferences of more than 1,800 vehicles per hour.

Summaries of maximum hourly flows on various major thoroughfares in New York have been made available through the courtesy of Mr. N. Cherniack, Statistical Analyst of the Port of New York Authority. These data are set forth in Table 13.

* Interference limited to northbound buses on Sheridan Road which are permitted to cross eastbound traffic streams.

TABLE 13

OBSERVED MAXIMUM HOURLY FLOWS—SELECTED CROSSINGS, PARKWAYS, AND STREETS—IN THE CITY OF NEW YORK

Location	Day	Date	Hour	CYCLE		NUMBER OF LANES		VEHICLES PER HOUR		
				Green	Total	Total	Free	Total	Per Lane at	
								Classified	Continued	
CROSSINGS, EXPRESS HIGHWAYS AND PARKWAYS										
Long Island Parkway		5-10-36	10-11 P. M.	60	60	2	2	4,530	2,275	2,275
Queensboro BridgeSun.	6-18-36	5- 6 P. M.	60	60	2	2	5,722	1,861	1,861 (a)
Queensboro BridgeThur.	10-24-36	6- 7 P. M.	60	60	3	3	4,414	1,471	1,471 (b)
Manhattan BridgeThur.	12-17-36	11-12 A. M.	60	60	2	2	5,566	1,783	1,783 (a)
Manhattan BridgeSat.	4- 4-36	9-10 A. M.	60	60	2	2	5,090	1,545	1,545 (a)
Holland TunnelSun.	11-20-27	5- 6 P. M.	60	60	2	2	2,450	1,225	1,225
Holland TunnelFri.	5-30-30	8- 9 A. M.	60	60	2	2	2,507	1,254	1,254
Holland TunnelFri.	5-21-37	6- 7 P. M.	60	60	2	2	1,404	1,404	1,404 (c)
Holland TunnelFri.	5-28-37	6- 7 P. M.	60	60	2	2	2,508	1,254	1,254
Holland TunnelFri.	5-28-37	6- 7 P. M.	60	60	2	1	1,148	1,148	1,148 (d)
George Washington BridgeSun.	7-19-36	11-12 P. M.	60	60	3	3	3,961	1,320	1,320

STREETS AND AVENUES

Park Ave. at 57th St.Tuc.	4-9-35	5- 6 P. M.	60	90	4	3	2,876	958	1,437
Park Ave. at 34th St.Mon.	3-11-35	5- 6 P. M.	60	90	5	2	1,755	867	1,301
Park Ave. at 57th St.Tuc.	7-27-37	5- 6 P. M.	60	90	4	3	2,265	755	1,132
5th Ave. at 57th St.Thur.	6-24-37	5- 6 P. M.	60	90	3	2	982	491	756
57th St. at 5th Ave.Thur.	6-24-37	5- 6 P. M.	22	90	3	2	783	391	1,600
5th Ave. at 57th St. and } 57th St. at 5th Ave. }Thur.	6-24-37	5- 6 P. M.	88	90	3	2	1,765	882	992
5th Ave. at 42nd St.Thur.	3-11-35	5- 6 P. M.	60	90	3	2	1,148	574	861
5th Ave. at 34th St.Tuc.	5- 4-37	10-11 A. M.	60	90	3	2	398	797	598
5th Ave. at 5th Ave.Tuc.	5- 4-37	10-11 A. M.	22	90	3	2	723	361	1,478
5th Ave. at 34th St. and } 34th St. at 5th Ave. }Tuc.	5- 4-37	10-11 A. M.	88	90	3	2	1,520	760	855

(a)—Upper Roadway.

(b)—Lower Roadway.

(c)—Fast Lane.

(d)—Slow Lane.

Intersection Movements

Mr. McIntyre's paper contains summaries of numerous observations of downtown street intersections made by the Bureau of Traffic Planning of the City of Pittsburgh. The more significant of these are set out as follows:

SPACE BETWEEN MOVING AUTOMOBILES AT INTERSECTIONS

<u>Number of Intersections</u>	<u>Number of Observations</u>	<u>Average Space in Feet</u>	<u>Remarks</u>
3	574	17.82	Free Movement
1	139	17.42	Following Street Car
1	71	12.8	Especially Dense Traffic

TIME TAKEN BY AUTOMOBILES TO CLEAR INTERSECTION
(12-FOOT SIDEWALK PLUS 36-FOOT ROADWAY)

<u>Type of Car</u>	<u>Number of Observations</u>	<u>Time in Seconds</u>	<u>Speed in Miles per Hour</u>	<u>Effective Free Movement in Seconds</u>	<u>Headway Dense Traffic in Seconds</u>
Passenger:					
First Car Group	93	3.92	10.8	2.01	1.70
Following Cars	161	2.77	15.3	1.43	1.20
Mixed Group	199	2.95	15.3	1.60	1.38
Truck:					
First Car Group	21	4.61	10.9	2.78	2.44
Following Cars	10	4.06	12.4	2.42	2.14

Mr. McIntyre's discussion of traffic movements at and near intersections is of such interest that it is quoted somewhat fully, as follows:

"Cross interference shows further restrictive effect in the delay that follows the stopping of a vehicle. Some data showing the time taken to start automobiles at an intersection, after the 'Go' signal has been given, have been obtained as follows:

<u>Position of Car in Line</u>	<u>Number of Observations</u>	<u>Average Time in Seconds</u>
First Car	224	1.6
Second Car	224	2.9
Third Car	202	4.1
Fourth Car	185	5.1
Fifth Car	101	7.4
Sixth Car	81	7.6

"The average time required to start equals approximately 1.41 times the position of the car in line. Naturally, the more stops that are caused by intersections which are too close together, the more frequently will this delay occur and the greater will be its effect in reducing street capacity. One of the fundamentals of good traffic regulation is to keep the traffic moving. The following simple illustration, involving the sixth and last car of a line stopped at an intersection, will show the importance of effective headway (rate of flow, 1.275 cars per hour):

<u>Description</u>	<u>Time Required in Seconds</u>
For Sixth Car to Start	7.6
To Travel 48 feet, at 10.8 Miles per Hour, after Starting	3.92
To Travel 48 feet, at 15.3 Miles per Hour, through the Intersection	2.77
To Travel another 51 feet, at 13.0 Miles per Hour	2.67
Total Time	16.96
Effective Headway	2.82

“Assume the six cars to be stopped with a distance of 3 feet between each car, and each car to be 14 feet long. The rear of the sixth car will be 99 feet from the intersection, and must travel 147 feet for the rear of the car to clear the far curb of a 36 foot roadway. The data in Table 2* demonstrate that the first passenger car of a group will travel 48 feet in 3.92 seconds and that the following cars of this group will travel 48 feet in 2.77 seconds. The speed of the first car in traveling 48 feet was 10.8 miles per hour and that of following cars, as they cleared the intersection, 15.3 miles per hour. Assuming the average of these two speeds as the speed which the sixth car made in the remaining 51 feet which it was required to travel, gives a total of 17 seconds before this sixth car clears the intersection, or an effective headway for these 6 cars of 2.82 seconds, and a rate of flow of 1,275 cars per hour per lane.”

“These data** show: (a) The time required by vehicles of various types to clear their own lanes; (b) the delay to following traffic; (c) the time required to complete the turn; and, (d) the delay to oncoming traffic where the turn crosses such traffic.

“Turns are designated by the number of the lane from which, and to which, the turn is made. Lanes are numbered across both streets starting from the corner about which the turn is made. Average delays to following traffic range from zero to 6.1 seconds, depending on the type of turn, whether the streets are one-way or two-way, the type of vehicle, the volume of oncoming traffic, etc. Interference to oncoming traffic ranges to as high as 15.3 seconds, and time to complete the turn to as much as 22.6 seconds in the case of a street car train making the ordinary left turn from one two-way, four-lane street to another.”

* Tabulation on Page 93

** Shown in Table 14

TABLE 14
 DELAYS CAUSED BY TURNS—PITTSBURGH

Type of Turn		TIME REQUIRED IN SECONDS					DELAY IN SECONDS DUE TO INTERFERENCE WITH ONCOMING			Delay, in Seconds, in its Out Lane, at Straight-Ahead Speeds (in Miles per Hour) of		
From Lane No. *	To Lane No. *	Type of Vehicle	Number of Observations	To its Out Lane	To Turn	Lane No. 3 *	Lane No. 2 †	Lane No. 1 ‡	6	12	18	Actual
(1)	(2)	(3)	(4)	(5)	(6)	(7)	(8)	(9)	(10)	(11)	(12)	(13)
		Passenger	18	2.5	4.5	—	—	—	0.0	1.0	1.5	0.9
1	1	Trucks	10	2.8	5.0	—	—	—	0.0	0.6	1.4	0.6
1	3	Passenger	76	3.2	5.2	—	—	—	0.0	1.3	1.9	1.1
1	3	Trucks	16	4.1	6.5	—	—	—	0.0	1.5	2.4	1.4
1	4	Passenger	22	3.0	5.0	—	—	—	0.0	0.0	0.9	0.0
1	4	Trucks	16	3.2	6.3	—	—	+	0.0	0.0	0.7	0.0
2	2	Passenger	65	2.8	5.7	—	—	—	0.0	1.3	1.8	1.2
2	2	Trucks	18	4.2	6.6	—	—	—	0.0	2.0	2.8	2.0
2	3	Passenger	103	3.3	5.6	—	—	—	0.3	1.8	2.3	1.7
2	3	Trucks	26	3.9	6.8	—	—	—	0.0	1.7	2.5	1.7
2	4	Passenger	45	3.4	5.5	—	—	—	0.1	1.9	2.4	1.8
2	4	Trucks	29	3.3	6.8	—	—	—	0.1	1.1	1.9	1.1
3	2	Passenger	167	4.0	6.9	—	2.7	2.7	1.0	2.5	3.0	2.4
3	2	Trucks	30	5.6	9.1	—	1.3	1.5	1.3	3.4	3.4	3.4
3	3	Passenger	17	3.2	5.7	—	5.0	1.8	0.2	1.7	2.2	1.6
3	3	Trucks	17	1.9	6.2	—	1.5	2.1	0.6	2.7	5.5	2.7
4	1	Passenger	21	8.2	11.1	1.2	3.0	2.5	1.3	6.3	6.0	6.1
4	1	Trucks	16	8.7	11.6	3.7	5.3	4.5	3.5	6.1	7.0	6.0
4	1	Passenger	20	2.5	3.8	—	—	—	0.0	0.8	1.3	0.7
4	1	Trucks	7	2.6	4.5	—	—	—	0.0	0.0	0.4	0.4
2+	2+	Passenger	90	2.4	4.3	—	—	—	0.0	0.9	1.4	0.8
3	2	Trucks	29	2.7	4.9	—	—	—	—	0.5	1.3	0.5
2+	2+	Trucks	18	3.9	9.7	—	4.1	1.9	1.6	3.7	4.5	3.7

* All left turns, except as indicated in Column (2).

† Right turn.

‡ Actual speed.

Similar observations covering intersection movements of various types in Chicago were carried on by the staff of the Committee on Local Transportation during November and December, 1937. In order to eliminate so far as possible any delays to free movement of automobiles due to pedestrian or other interferences, intersection movements were studied at the following intersections on Michigan Avenue:

Wacker Drive, Washington Street, Adams Street, and
 Randolph Street, Monroe Street, Jackson Street.

Observations were made during normal weather and at times when pavements were entirely free of ice or snow. About two-thirds of the straight crossing movement studies covered vehicles moving along Michigan Avenue across Washington Street (80 foot width)—the other observations covering movements across Monroe and Adams Streets (66 foot width). Right turn movements observed were from Randolph, Washington, Adams and Jackson Streets into Michigan Avenue and from Michigan Avenue into Wacker Drive and Jackson Street. About two-thirds of the left turn movements were from Wacker Drive into Michigan Avenue—the remainder being from Randolph and Washington Streets into Michigan Avenue and from Michigan Avenue into Washington and Monroe Streets. All instances where free movement of vehicles was delayed by cross streams of either vehicular or pedestrian traffic were eliminated. The following tabulation shows a summary of the observations made:

TABLE 15

AVERAGE TIME REQUIRED FOR VARIOUS MOVEMENTS OF PASSENGER CARS THROUGH INTERSECTIONS — CENTRAL BUSINESS DISTRICT, CHICAGO

Position in Line	Time to Start After "Go" Seconds	Time to Intersection Seconds	TIME THROUGH INTERSECTION					
			STRAIGHT THROUGH		RIGHT TURN		LEFT TURN	
			Number Observations	Seconds	Number Observations	Seconds	Number Observations	Seconds
1st Car	—	—	15	6.4	—	—	—	—
1st Car	—	—	—	—	12	8.0	—	—
1st Car	—	—	—	—	—	—	25	10.2
2nd Car	2.3	3.3	—	—	4	6.5	—	—
2nd Car	2.6	2.1	—	—	—	—	4	8.1
3rd Car	3.3	4.0	4	4.2	—	—	—	—
3rd Car	3.3	6.0	—	—	4	5.9	—	—
3rd Car	3.8	4.5	—	—	—	—	19	6.7
4th Car	3.8	5.6	5	4.0	—	—	—	—
4th Car	4.0	6.0	—	—	9	8.0	—	—
4th Car	4.5	6.4	—	—	—	—	13	6.9
5th Car	5.7	7.0	9	4.4	—	—	—	—
5th Car	6.2	8.3	—	—	20	7.0	—	—
5th Car	5.3	7.2	—	—	—	—	8	6.9

Field observations indicated that the average distance between cars standing in line awaiting traffic signal is approximately 5 feet so that with an average length of 14 feet per vehicle, the total distance center to center between standing vehicles is approximately 19 feet. Additional studies were made of the length of time required for cars standing in line to start after receiving "GO" signal, and these data are summarized as follows:

AVERAGE TIME REQUIRED TO START PASSENGER
AUTOMOBILES AFTER THE "GO" SIGNAL

<i>Position in Line</i>	<i>Number of Observations</i>	<i>Seconds</i>
2nd Car	13	2.60
3rd Car	40	3.90
4th Car	60	4.66
5th Car	68	6.06
6th Car	26	6.09

The small increment of time noted for the 6th car may be attributed to the fact that this car was frequently observed to be in motion at a low speed when the 5th car was starting. If such running starts were to be eliminated, it is estimated that the average time required for the 6th car would be at least 6.5 seconds.

The data covering straight crossing movements, right turn movements and left turn movements are plotted on Figure 26. No attempt was made to determine the exact shape of that portion of the curve covering acceleration. It is apparent, however, that the cars complete most of their acceleration in less than 50 feet. The several points plotted for each type of movement warrant the belief that a somewhat uniform speed prevails covering movements through the intersection. Therefore, straight lines were projected which represent the mean of the various movements recorded. From these curves, time required to travel the first 50 feet may be estimated as follows:

Straight Crossing Movements	5.3 Seconds
Left Turn Movements	6.2 Seconds
Right Turn Movements	7.7 Seconds

The average speed to and through the intersection (after the first 50 feet) expressed in feet per second is as follows:

Straight Crossing Movements	21.4 Feet per Second
Left Turn Movements	18.0 Feet per Second
Right Turn Movements	10.4 Feet per Second

Estimates based on these figures are compared with the computation made by Mr. McIntyre as a result of the Pittsburgh observations in the following tabulation:

	TIME REQUIRED IN SECONDS			
	CHICAGO			
	<i>Pittsburgh</i>	<i>Straight Through</i>	<i>Left Turn</i>	<i>Right Turn</i>
For 6th Car to Start	7.6	6.5	6.5	6.5
To Travel 48 Feet	3.9	5.1	6.0	7.4
To Travel Second 48 Feet	2.8	2.2	2.7	4.6
To Travel Next 51 Feet	2.7	2.4	2.8	4.9
	17.0	16.2	18.0	23.4
Effective Headway	2.8	2.7	3.0	3.9
Cars per Minute	21	22	20	15

Although it was not so stated in Mr. McIntyre's paper, the presumption is that his figures as noted above are based on straight crossing movements. There is no information as to whether the Pittsburgh observations excluded delays due to cross traffic. The use of the Chicago observations would result in a difference in headway of only one-tenth of one second or a total difference in flow of one car per minute. However, the Chicago observations show clearly the somewhat greater time required for making left turn movements and resulting increase in headway and decrease in flow of vehicles. The right turn movement—involving as it does a turn on a shorter radius—results in a still slower speed and a further decrease in flow. On the whole, the Chicago observations provide an approximate check of the Pittsburgh studies and provide a basis for the determination of capacity of intersections, ramp entrances and ramp exits under varying local conditions of vehicular traffic flow, physical characteristics of intersection, pedestrian flow and other factors.

NORMAL CAPACITY OF SUPERHIGHWAY FACILITIES

An estimate of the normal working capacity of the several parts of a superhighway is a necessary preliminary to its design as well as to the determination of the value and suitability of such a structure for the relief of congestion and improvement of safety. Studies of capacity and speed described hereinabove provide the basis for such estimate.

Throughout this memorandum, existing traffic volumes are expressed in terms of normal year round conditions. Admittedly, there are monthly and daily variations in these peak hour volumes, which may vary substantially from the normal. In this appraisal of normal capacity, therefore, average figures will be utilized, which may be substantially less than known tests of capacity developed under conditions of actual congestion. The use of such average figures will provide a margin of safety whereby the several component parts of the superhighway project will each have latent capacity for the accommodation of the occasional surge in traffic which may be expected.

Unobstructed Traffic Lane

Maximum observed hourly rates of traffic flow per average lane have been noted as follows:

<i>Location</i>	<i>Hourly Traffic</i>	<i>Refer to Table</i>
Pittsburgh	1,740	10
Pittsburgh	1,680	10
Chicago	1,803	12
New York	2,775	13
New York	1,861	13
New York	1,783	13
New York	1,545	13

With the exception of the Pittsburgh count which covered a two-lane bridge roadway—one lane for traffic in each direction—all other traffic volumes were over multiple lane highways.

Making allowance for the fact that these counts may have been made during favorable weather and during periods of congestion, it appears that a figure of

1,500 per lane per hour can be safely adopted for estimating normal working capacity and this figure will be used in this analysis.

Partially Obstructed Traffic Lane

A traffic lane may become partially obstructed through—

1. restriction of use by means of signal or other control.
2. grade crossings.
3. right turn movements.
4. left turn movements.
5. vehicles stopping for deliveries at curb.
6. parking of vehicles.
7. pedestrian interferences, and
8. vehicles entering or leaving outer lanes.

The three inner lanes of both express roadways of the proposed west side superhighway as planned would be entirely free of all of these obstructions throughout the 7 mile grade separated section between Canal Street and the west city limits. The outer lanes would be subject only to such obstructions as may be occasioned by vehicles parking and vehicles entering or leaving the express roadways. The relatively flat berms and slopes, planned adjacent to the outer curb throughout most of the grade separated sections, provide ample space for parking disabled vehicles so that the interference to the full flow of traffic in the outer lanes from parking vehicles would be negligible. The ramp layouts have been planned so as to minimize interferences from vehicles entering or leaving the outer lanes. Therefore, it may be estimated that all four lanes of the express roadways west of Canal Street may be utilized to their full capacity, thus providing normal working capacity of 6,000 vehicles per hour in each direction.

The section between Canal Street and Michigan Avenue is subject to the various interferences resulting from grade crossings and cross traffic, both vehicular and pedestrian. Between Canal Street and LaSalle Street obstructive left turn movements should be prohibited so that the full use of the lanes devoted to straight crossing movements will be permitted during the "go" time as controlled by traffic signals at each intersection. It appears, therefore, that the capacity of all lanes except the outer lane at the intersection from Canal Street to LaSalle Street may be estimated on the basis of developed capacity on similar roadways, both in Chicago and elsewhere. The following tabulation shows hourly traffic flow developed on heavily traveled arteries in various cities, as abstracted from the foregoing data.

TRAFFIC FLOW — RATE PER LANE

<u>Thoroughfare</u>	<u>City</u>	<u>Hourly Rate</u>
Boulevard of the Allies	Pittsburgh	754
Grand River Avenue	Detroit	890
Jefferson Avenue	Detroit	919
Park Avenue	New York	958
Michigan Avenue Bridge	Chicago	916
LaSalle Street	Chicago	800
Warren Boulevard	Chicago	752

It appears that the working capacity of the inner and intermediate lanes between Canal Street and LaSalle Street may be estimated at 800 per hour. This figure checks closely with the lane capacity as computed from observations on intersection movements with all cars stationary at the beginning of the "go" signal, and assuming almost two-thirds of the signal cycle devoted to east and west movement as would be permitted at the intersections of the Congress Street thoroughfare with Canal Street, Wells Street, Sherman Street and LaSalle Street.

At Clark Street and intersections to the east, it is planned to permit left turn movements so that straight crossing movements would be generally confined to the two intermediate lanes in each roadway. Such movements would be partially obstructed at these intersections by left turning movements. The left turning movements which would be obstructive to the straight crossing movements of the heavy rush hour traffic would be confined to movements from the opposing lighter traffic streams. The total obstruction which would result therefrom is estimated to reduce the average capacity of the intermediate lanes devoted to straight crossing movements to three-quarters of their full unobstructed capacity, or 600 cars per hour per lane.

Right turning movements would be confined to outer lanes. Assuming that the restrictions of right turn movements to the east and west "go" signal interval, the capacity of the outer lane for right turn movements as computed from observations of intersection movements would be 420 vehicles per hour—based on an approximately even division of the east and west and north and south intervals in the signal cycle, and making an allowance for the yellow interval.

In the section between Clark Street and State Street it is proposed to limit the use of inner lanes to vehicles about to make left turn movements. The observations previously analyzed show a total capacity of 1,200 vehicles per hour per lane. With an even division of the traffic signal cycle, this total would be reduced to approximately 560 per hour. Interferences from the opposing traffic stream would further reduce the efficient use of this lane to an estimated useful working capacity for the inner lane and for left turn movements at intersections of 300 vehicles per hour.

Ramps

The studies of intersection movements at Pittsburgh and Chicago—see pages 31 to 40 and Tables 14 and 15—furnish a sound basis for estimating ramp capacity. In that these observations covered movements under normal conditions in congested areas and at street intersections where all traffic was subject to stop and go regulations, there can be no question as to the capacity of ramp lanes determined by the character of movement, percentage of go time and interference of opposing traffic streams. Eliminating opposing traffic interference, rate traffic flow per lane per hour can be estimated at:

Straight crossing movements	1,320 per hour.
Left turn movements	1,200 per hour, and
Right turn movements	900 per hour.

Each ramp must be analyzed separately and its capacity determined by the application of local conditions of traffic control, character of movements and opposing traffic stream interferences. A similar analysis can be made of other special locations where restrictions to the free flow of traffic may result from grade crossings, signal control or turning movements.

ESTIMATED INITIAL USE OF SUPERHIGHWAY

Factors to be considered in estimating the initial use of the west side superhighway include not only safety and convenience but also time savings. In the complete absence of cross traffic and pedestrians, there will be no impediment to the free flow of vehicles between terminals, so that over-all speeds will be equal to average cruising speeds.

It follows that traffic conditions on the proposed superhighway will be equal or superior to conditions on uncongested sections of rural highways. The Ohio tests, see Table 4, show mean smoothed speeds on various Ohio highways ranging from 37.0 to 45.3 miles per hour. The average free running speed of buses was noted to be 41.6 miles per hour. The Illinois tests made in the Chicago metropolitan district showed a range of from 33.4 to 49.2 miles per hour.

It is recommended that minimum as well as maximum speed limitations be placed on passenger vehicles operated on the proposed highway. Assuming the adoption of such regulations, it is believed that average cruising speeds of 40 miles per hour may be utilized conservatively as a basis for estimating travel time.

The test runs on various west side thoroughfares as above summarized show over-all speeds ranging, in general, from 16 to 20 miles per hour. Only a limited number were below 16 or above 20 miles per hour. Time savings, therefore, may be estimated at about one-half of present travel time. From the west city limits to the loop district, this will be more than 20 minutes—with proportional savings for shorter trips.

Estimates of use of proposed superhighway are based on existing traffic volumes. No attempt has been made to forecast future increases. Eastbound traffic during the maximum half hour is analyzed in detail. Peak hour westbound traffic in the area studied is substantially the same as the morning peak hour traffic eastbound.

The many advantages of the proposed off-grade traffic facilities to be provided by the proposed west side superhighway will undoubtedly attract traffic from the entire area between Chicago Avenue and Roosevelt Road.

Estimates of the number of vehicles to be diverted to the superhighway are based on existing traffic densities on east and west thoroughfares between Chicago Avenue on the north and Roosevelt Road on the south. Relatively high percentages of diversion are estimated from Washington (Warren) Boulevard, Jackson Boulevard and Madison Street west of Garfield Park. These thoroughfares now carry most of the through east and west traffic to and from the central area.

TABLE 16

ESTIMATES OF ADDITIONS AND DEDUCTIONS OF TRAFFIC TO AND FROM THE PROPOSED WEST SIDE SUPERHIGHWAY BASED ON EXISTING PASSENGER VEHICLE MOVEMENTS DURING MAXIMUM 30-MINUTE PERIOD INBOUND

<i>East and West Thoroughfare</i>	<i>Between</i>	<i>Number Increase of or De- Vehicles create Existing over Eastbound Previous Traffic Section</i>		VEHICLES TO OR FROM SUPERHIGHWAY			<i>Net Traffic on Superhighway</i>
		<i>Per Cent</i>	<i>Per Cent</i>	<i>Number On</i>	<i>Number Off</i>		
Chicago Avenue Lake Street	Austin Boulevard	120	—	10	12	—	
Washington Boulevard Madison Street	and	481	—	60	289	—	
Jackson Boulevard Roosevelt Road	Central Avenue (Columbus Park)	336	—	60	202	—	
		309	—	75	232	—	
		236	—	25	59	—	
					813	—	813
Chicago Avenue Lake Street	Central Avenue	128	+ 8	10	1	—	
Washington Boulevard Madison Street	and	118	+ 44	25	11	—	
Jackson Boulevard Harrison Street		487	+ 6	60	4	—	
Roosevelt Road	Laramie Avenue	406	+ 70	60	42	—	
		542	+ 233	75	175	—	
		114	+ 114	25	29	—	
		341	+ 105	25	27	—	
					289	—	1,102
Chicago Avenue Lake Street	Laramie Avenue	167	+ 39	10	4	—	
Washington Boulevard Madison Street	and	190	+ 72	25	18	—	
Jackson Boulevard Harrison Street		584	+ 97	60	59	—	
Roosevelt Road	Cicero Avenue	367	— 39	60	—	23	
		542	—	—	—	—	
		139	+ 25	25	6	—	
		272	— 69	25	—	17	
					87	40	1,189
Chicago Avenue Lake Street	Cicero Avenue	245	+ 78	10	8	—	
Washington Boulevard Madison Street	and	259	+ 69	25	17	—	
Jackson Boulevard Harrison Street		588	+ 4	60	2	—	
Roosevelt Road	Independence Boulevard	457	+ 70	60	42	—	
		652	+ 110	75	83	—	
		89	— 50	25	—	12	
		321	+ 49	25	12	—	
					164	52	1,301
Chicago Avenue Lake Street	Independence Boulevard	199	— 46	10	—	5	
Washington Boulevard Madison Street	and	235	— 24	25	—	6	
Jackson Boulevard Harrison Street		903	+ 315	60	189	—	
Roosevelt Road	Homan Avenue	230	— 207	60	—	124	
		770	+ 118	75	88	—	
		103	+ 14	25	3	—	
		236	— 85	25	—	21	
					280	156	
						60	
						216	1,365

Add number leaving at Homan Avenue

TABLE 16—(Continued)

ESTIMATES OF ADDITIONS AND DEDUCTIONS OF TRAFFIC TO AND FROM THE PROPOSED WEST SIDE SUPERHIGHWAY BASED ON EXISTING PASSENGER VEHICLE MOVEMENTS DURING MAXIMUM 30-MINUTE PERIOD INBOUND

<u>East and West</u> <u>Thoroughfare</u>	<u>Between</u>	<u>Number Increase</u> <u>of or De-</u> <u>Vehicles</u> <u>Existing</u> <u>Traffic</u>		<u>Increase</u> <u>or De-</u> <u>crease</u> <u>over</u> <u>Previous</u> <u>Section</u>		<u>VEHICLES TO OR FROM</u> <u>SUPERHIGHWAY</u>			<u>Net Traffic</u> <u>on</u> <u>Superhighway</u>
		<u>Per</u> <u>Cent</u>	<u>Number</u> <u>On</u>	<u>Number</u> <u>Off</u>					
				Brought Forward			216	1,365	
Chicago Avenue		190	— 9	10	—	—			
Lake Street	Homan Avenue	102	—133	20	—	27			
Washington Boulevard		1,308	+405	60	243	—			
Madison Street	and	88	—142	60	—	85			
Jackson Boulevard		710	— 60	75	—	45			
Harrison Street	Sacramento Boulevard	48	— 55	20	—	11			
Roosevelt Road		277	+ 41	20	8	—			
							251	168*	1,616
Chicago Avenue		157	— 55	10	—	3			
Lake Street	Sacramento Boulevard	116	+ 14	20	3	—			
Washington Boulevard		1,790	+482	55	264	—			
Madison Street	and	72	— 16	55	—	9			
Jackson Boulevard		740	+ 30	60	18	—			
Harrison Street	Oakley Boulevard	57	+ 9	20	2	—			
Roosevelt Road		429	+152	20	30	—			
							317	12	
	Add number leaving at Sacramento Boulevard							108	
								120	1,813
Chicago Avenue		82	— 75	8	—	7			
Lake Street	Oakley Boulevard	114	— 2	15	—	—			
Washington Boulevard		1,890	+100	50	50	—			
Madison Street	and	83	+ 11	50	6	—			
Jackson Boulevard		794	+ 54	60	32	—			
Harrison Street	Damen Avenue	79	+ 22	15	3	—			
Roosevelt Road		508	+ 79	15	12	—			
							103	7	1,909
Chicago Avenue		104	+ 22	8	2	—			
Lake Street		99	— 15	15	—	2			
Washington Boulevard	Damen Avenue	1,671	—219	50	—	110			
Madison Street		85	+ 2	50	1	—			
Monroe Street	and	81	+ 81	30	24	—			
Adams Street		32	+ 32	30	10	—			
Jackson Boulevard	Paulina Street	884	+ 90	60	54	—			
Van Buren Street		65	+ 65	30	19	—			
Harrison Street		96	+ 17	15	3	—			
Roosevelt Road		554	+ 46	15	7	—			
							120	112	

* 60 leave at Independence Boulevard and 108 at Sacramento Boulevard.

TABLE 16—(Continued)

ESTIMATES OF ADDITIONS AND DEDUCTIONS OF TRAFFIC TO AND FROM THE PROPOSED WEST SIDE SUPERHIGHWAY BASED ON EXISTING PASSENGER VEHICLE MOVEMENTS DURING MAXIMUM 30-MINUTE PERIOD INBOUND

<i>East and West Thoroughfare</i>	<i>Between</i>	<i>Number of Vehicles Existing Traffic</i>		<i>Increase or Decrease over Previous Section</i>		VEHICLES TO OR FROM SUPERHIGHWAY			<i>Net Traffic on Superhighway</i>	
		<i>Eastbound</i>	<i>Westbound</i>	<i>Per Cent</i>	<i>Number</i>		<i>On</i>	<i>Off</i>		
					<i>To</i>	<i>From</i>				
									1,909	
		Brought Forward								
		Cars Off							112	
		Add Number Leaving at Paulina Street							69	
									181	1,728
		Cars On					120			1,848
Chicago Avenue		74	- 30	8	—	2				
Lake Street		152	+ 53	20	11	—				
Washington Boulevard		1,450	-221	50	—	110				
Madison Street	Paulina Street	62	- 23	50	—	11				
Monroe Street		100	+ 19	30	6	—				
Adams Street	and	109	+ 77	3	23	—				
Jackson Boulevard		790	- 94	60	—	56				
Van Buren Street	Throop Street	63	—	30	—	—				
Ogden Avenue		427	+427	25	107	—				
Harrison Street		171	+ 75	10	8	—				
Roosevelt Road		652	+ 98	15	15	—				
							170	179*		2,018
Lake Street		107	- 45	15	—	7				
Randolph Street		247	+247	25	59	—				
Washington Boulevard	Throop Street	1,100	-350	50	—	175				
Madison Street		93	+ 31	50	15	—				
Monroe Street		98	- 2	30	—	1				
Adams Street	and	95	- 14	30	—	4				
Jackson Boulevard	Morgan Street	775	- 15	60	—	9				
Van Buren Street		38	- 25	30	—	8				
Harrison Street		152	- 19	20	—	4				
Roosevelt Road		619	- 33	20	—	7				
							74			215
		110 leave at Racine Avenue								110
									325	1,767
Lake Street		159	+ 52	20	10	—				
Randolph Street		183	- 64	25	—	16				
Washington Boulevard	Morgan Street	952	-148	50	—	74				
Madison Street		93	—	50	—	—				
Monroe Street		153	+ 55	30	16	—				
Adams Street	and	85	- 10	30	—	3				
Jackson Boulevard	Desplaines Street	759	- 16	65	—	10				
Van Buren Street		25	- 13	30	—	4				
Harrison Street		108	- 44	20	—	9				
Roosevelt Road		480	-139	20	—	28				
							26**	144		1,623

69 leave at Damen Avenue and 110 at Racine Avenue.

** On at Canal Street.

TABLE 16—(Continued)

ESTIMATES OF ADDITIONS AND DEDUCTIONS OF TRAFFIC TO AND FROM THE PROPOSED WEST SIDE SUPERHIGHWAY BASED ON EXISTING PASSENGER VEHICLE MOVEMENTS DURING MAXIMUM 30-MINUTE PERIOD INBOUND

<i>East and West Thoroughfare</i>	<i>Between</i>	<i>Number Increase of on De- Vehicle crease Existing or</i>		VEHICLES TO OR FROM SUPERHIGHWAY		<i>Net Traffic on Superhighway</i>		
		<i>Eastbound Traffic</i>	<i>Westbound Section</i>	<i>Per Cent</i>	<i>Number On Off</i>			
		Brought Forward					1,623	
Lake Street	Desplaines Street	122	- 37	25	—	9		
Randolph Street		114	- 69	30	—	21		
Washington Boulevard		800	-152	55	—	84		
Madison Street		54	- 39	55	—	21		
Monroe Street	and	194	+ 41	30	12	—		
Adams Street	Clinton Street	65	- 20	30	—	6		
Jackson Boulevard		708	- 51	75	—	38		
Van Buren Street		-8	+ 23	30	7	—		
Harrison Street		111	+ 3	20	1	—		
Roosevelt Road		-487	+ 7	20	1	—		
					21*	179	1,444	
Lake Street	Clinton Street	123	+ 1	25	—	—		
Randolph Street		157	+ 43	30	13	—		
Washington Boulevard		724	- 76	55	—	42		
Madison Street		51	- 3	55	—	2		
Monroe Street	and	177	- 17	30	—	5		
Adams Street	Canal Street	65	—	30	—	—		
Jackson Boulevard		582	-126	75	—	95		
Van Buren Street		54	+ 6	30	2	—		
Harrison Street		105	- 6	20	—	1		
Roosevelt Road		505	+ 18	20	4	—		
					19*	145		
		Off from Canal Street					83	
						228	1,216	
Lake Street	Canal Street	124	+ 1	25	—	—		
Randolph Street		210	+ 53	30	16	—		
Washington Boulevard		653	- 71	60	—	43		
Madison Street		73	+ 22	50	11	—		
Monroe Street	and	140	- 37	30	—	11		
Adams Street	Franklin Street	63	- 2	30	—	1		
Jackson Boulevard		-18	-164	75	—	123		
Van Buren Street		80	+ 26	30	8	—		
Harrison Street		173	+ 68	20	14	—		
Roosevelt Road		-480	- 25	20	—	5		
					49	183 ^b		
		On from Morgan Street				26		
		On from Desplaines Street				21		
		On from Clinton Street				19		
					115	1,231		
		Driveway				30	10	1,251

* On at Canal Street.

^b 83 off at Clinton Street.

The estimated initial flow of traffic at the maximum point at Ashland Avenue is 2,020 vehicles in the maximum 30-minute period or about two-thirds of the convenient capacity of the thoroughfare as planned. By utilizing the average ratio for east and west traffic in Tables 2 and 3, it may be estimated that the total initial typical week-day flow past this maximum point will be about 60,000 vehicles in 24 hours.

Data on turning movements during rush hours at and between various thoroughfares intersecting Washington Boulevard and other east and west arteries were analyzed as a basis for estimates of volumes of traffic entering or leaving the superhighway as summarized in Table 16. These analyses—together with other factors such as increase or decrease in total east and west traffic volumes at various key points, time savings and convenience of access of ramps—were utilized in estimating probable number of vehicles entering and leaving the several ramps. The results of these studies are summarized as follows:

TABLE 17
SUMMARY OF DATA ON RAMPS AND CONNECTIONS

Location Near	Gradient in per Cent	Width in Feet	For Traffic on Express Roadways to the	Serving Vehicles with Origins or Destinations in Districts Reached By	MAXIMUM 30 MINUTES		
					Capacity	Initial Use— A.M. Rush Hour	Per Cent Initial Use to Capacity
Michigan	0	*	West	Michigan (Outer Drive)	360	170	47
Wabash	0	*	West	Wabash	360	110	30
State	0	*	West	State	360	110	30
Plymouth	0	***	West	Plymouth	150	50	33
Dearborn	0	*	West	Dearborn	360	110	30
Federal	0	**	West	Federal	210	50	24
Clark	0	*	West	Clark	360	100	28
LaSalle-Sherman	0	*	West	LaSalle-Sherman	485	140	29
Wells	0	**	West	Wells	285	80	28
River Plaza	3.25	24	West	Franklin-Market (Wacker)	520	330	63
Canal	0	**	West	Canal	285	100	35
Clinton	6.00	24	West	Clinton	590	230	39
Desplaines	4.00	24	West	Desplaines	470	180	38
Morgan	4.00	12	West	Morgan-Halsted	400	145	36
Throop	4.00	18	East	Throop-Ashland	420	75	18
Throop	4.00	18	West	Throop-Racine	520	325	62
Paulina	5.00	24	East	Paulina (Medical Center)	480	170	35
Damen	4.00	24	East	Damen	360	120	33
Damen	4.00	24	West	Damen-Ogden	360	180	50
Oakley	4.00	24	East	Oakley-Western	450	105	23
Campbell	2.00	24	West	Western	535	5	1
Sacramento	3.00	24	East	Sacramento	490	315	64
Sacramento	3.00	24	West	Sacramento	535	120	22
Homan	3.00	24	East	Homan-Central Park	450	250	56
Independence	3.00	24	East	Independence-Pulaski	535	280	52
Independence	4.00	24	West	Independence	490	215	44
Kilpatrick	2.50	24	East	Cicero	450	165	37
Cicero	3.00	24	West	Cicero	535	55	10
Laramie	3.00	24	East	Laramie	450	90	20
Central	3.00	24	East	Central	490	135	28
Columbus Park—							
North Connection	3.00	36	East	Jackson	1,800	890	50
South Connection	3.00	36	East	Harrison-Austin	1,800	75	4

* Right and left turning movements to and from express roadways at grade intersection.

** Right turns only at grade intersection.

*** Left turns only at grade intersection.

DISTRIBUTION OF TRAFFIC IN AND NEAR THE CENTRAL BUSINESS DISTRICT

Cordon counts of vehicles and passengers entering and leaving the central business district bounded by Roosevelt Road on the south and the Chicago River on the north and west which have been made during the period 1926-1939 are summarized in Table 18 on page 59.

The density of existing inbound traffic during the maximum 30-minute period in and near the central business district is shown on Figure 19. It is substantially less than the maximum use which can be developed through the efficient use of existing roadways. The existing heavy concentration of traffic on Washington and Jackson Boulevards is undoubtedly the result of freedom from street car traffic throughout most of the length of these thoroughfares.

With the elimination of all east and west street car movements in the area east of the Chicago River, which will result from the construction of street car subways as proposed herein, there will be nothing to prevent a much more uniform distribution of east and west traffic in this terminal area.

A study of the redistribution of such traffic after the construction of the proposed West Side superhighway has been made and is shown on Figure 20. In this study weight has been given to the superior facilities offered by the 8-lane Congress Street terminal east of Wells Street as compared with the existing narrow roadways in the east and west streets in the loop district. The result of this will be to attract east and west traffic to the new thoroughfare, effecting a re-routing of traffic so that certain vehicles now reaching their destination in the central business district by way of east and west streets will in the future utilize Congress Street and north and south loop streets. Any estimates of redistribution of passenger vehicle traffic after the completion of the Congress Street improvement are necessarily approximations in the absence of exact data on origins and destinations.

It is evident that the heavy concentration of traffic along Congress Street near the south end of the central business district will have no adverse effect on the orderly flow of traffic on the loop streets. On the contrary, the heavier concentrations on the present downtown street system will in the future be found near the outer fringes of the district.

Automobile Storage and Parking Facilities

A survey was conducted during the summer of 1936 by the State Division of Highways of all automobile storage facilities in the area bounded by Chicago Avenue, Halsted Street and Roosevelt Road. This area was subdivided into three districts, as follows:

- (a) Loop district, bounded by Lake Street, Wells Street, Van Buren Street and Michigan Avenue;
- (b) The central business district, bounded by the Chicago River on the north and west, Harrison Street on the south, and Lake Michigan on the east (except the loop district); and
- (c) The central district, all of the remainder of the area.

TABLE 18
 NUMBER OF PASSENGERS ENTERING AND LEAVING CENTRAL BUSINESS DISTRICT—CHICAGO
 TYPICAL WEEK DAY IN MAY—7:00 A. M. TO 7:00 P. M.

	STREET CARS		ELEVATED ^{a, b}		STEAM RAILROAD		MOTOR BUSES		PASSENGER AUTOS ^c		TOTAL	
	In	Out	In	Out	In	Out	In	Out	In	Out	In	Out
1926	294,958	283,967	256,286	231,320	118,857	103,275	44,391	44,878	166,367	159,157	880,859	822,517
1928	282,013	281,041	243,594	216,241	124,107	109,310	47,472	50,254	196,875	188,594	894,059	843,380
1929	296,690	290,592	256,575	196,988	132,723	115,996	95,161	62,264	203,996	184,084	925,145	849,024
1931	281,312	271,007	191,540	159,469	119,742	108,290	46,500	44,187	203,916	189,120	843,810	772,073
1935	254,528	246,048	169,690	137,223	84,251	72,595	42,465	36,449	204,768	190,852	755,702	683,167
1936	246,781	235,391	200,212	164,845	92,144	75,367	46,812	41,171	215,849	205,765	801,798	722,539
1937	248,916	239,388	209,590	169,111	103,505	86,885	57,106	47,996	216,681	211,651	846,015	755,031
1938	228,236	222,751	193,005	166,855	94,208	81,511	57,270	52,235	230,414	233,917	812,135	757,072
1939***	253,182	228,172	203,142	174,840	99,970	87,291	54,100	48,711	244,980	233,340	839,574	772,534

^a Factor used in 1929 and previous years was 1.8 passengers per auto. In subsequent years, a factor of 1.7 was used.

^b * Includes Chicago, Aurora & Elgin Railroad Company and Chicago, North Shore & Milwaukee Railroad Company.

^c *** Winter count made in January.

Information was secured covering capacities of all of the parking lots and garages existing at that time, and also counts were made of in and out movements for the purpose of determining the actual use of these facilities. It was found that the average ratio of use to capacity varied with the location and cost of the storage facilities, and ranged from 2.5 in the loop district to 1.5 in the outer sections of the central district. A summary of this survey is shown in Table 19 on page 62.

A survey made by the Traffic Engineering Division of the City Department of Streets and Electricity in 1939 showed an increase in use of parking facilities in the central business district since 1936 of approximately 14 per cent. This increase applied to the use of garages and parking lots as shown in Table 19, would result in increasing the total estimated 12-hour use of all parking facilities to 95,000 on a typical week-day.

TABLE 19
AUTOMOBILE STORAGE AND PARKING FACILITIES (1936)
ESTIMATED CAPACITIES
12-HOUR PERIOD

	<i>Number</i>	<i>Estimated Capacity</i>	<i>Estimated Use 12-Hour Period</i>
GARAGES:			
Loop District	14	4,268	10,700
Central Business District	13	2,339	4,700
Central District	33	4,843	7,300
Total	60	11,450	22,700
PARKING LOTS:			
Loop District	26	1,725	4,300
Central Business District	70	10,289	20,600
Central District	102	9,586	14,400
Total	198	21,600	39,300
STREET PARKING:			
Central Business District		3,100	7,800
Central District		6,600	16,500
Total		9,700	24,300
Grand Total		42,750	86,300
CONSTANTS FOR 12-HOUR PERIOD:			
Loop District	2.5		
Central Business District	2.0		
Central District	1.5		
Street Parking	2.5		

The provision of more convenient and safe highway facilities which will result from building the West Side and other proposed superhighways will undoubtedly result in attracting additional motorists to the central district requiring additional facilities for storage of automobiles. Provision for parking facilities for some 500 vehicles is recommended through the construction of an open structure on Congress Street between Desplaines and Canal Streets. Garage and parking lot storage will undoubtedly be added in the central district from time to time to keep pace with the demand.

Any shortage can be met by the provision of large parking lots at the outskirts of the central district and the operation of short line low fare bus routes into and through the downtown area in conjunction therewith. This plan has recently been put into effect in Detroit with demonstrated success. If adopted, it would result in decreasing the traffic load on both superhighway terminals and downtown streets.

APPENDIX II

Estimates of Cost
of Subway Extensions
and the
West Side Superhighway

APPENDIX II

ESTIMATES OF COST OF SUBWAY EXTENSIONS AND THE WEST SIDE SUPERHIGHWAY

SUBWAY EXTENSIONS—SUMMARY OF ESTIMATES OF COST

Dearborn Street Subway—Congress Street Extension

A two-track subway along the line of Congress Street extended, from a connection with the Dearborn Street Subway at the south line of Van Buren Street to a point near Halsted Street, including a terminal loop between Wells Street and the Chicago River.

Tunnel—Single Track—between Stations	1,400 Lin. Ft.	<i>a</i>	\$ 376	\$ 526,400
Tunnel—Single Track—between Stations (Difficult Ground Conditions)	3,870 Lin. Ft.	<i>a</i>	655	2,534,850
Tunnel—With 18 Foot Center Platform	500 Lin. Ft.	<i>a</i>	1,125	562,500
Tunnel—With 22 Foot Center Platform (Difficult Ground Conditions)	500 Lin. Ft.	<i>a</i>	1,464	732,000
Turnout Sections	2 Each	<i>a</i>	176,000	352,000
Mezzanine Stations	3 Each	<i>a</i>	322,000	966,000
River Section				530,000
High Level Section—near Portal	660 Lin. Ft.	<i>a</i>	992	654,720
Approach to Portal	500 Lin. Ft.	<i>a</i>	402	201,000
Changes to Sanitary District Sewer				40,000
Right-of-Way				200,530
				Total \$7,300,000

Lake Street Subway Extension

A two-track subway along Lake Street from a connection with the Dearborn Street Subway at Lake Street and Milwaukee Avenue to a point near Ann Street (Racine Avenue).

Single Track Tunnel—between Stations	3,230 Lin. Ft.	<i>a</i>	\$ 376	\$1,214,480
Tunnel—with Center Platform	500 Lin. Ft.	<i>a</i>	1,125	562,500
Single Track Tunnel—with Side Platforms	1,000 Lin. Ft.	<i>a</i>	670	670,000
Typical Mezzanine Subway Stations	2 Each	<i>a</i>	322,000	644,000
High Level Subway—near Portal	660 Lin. Ft.	<i>a</i>	992	654,720
Approach to Portal	675 Lin. Ft.	<i>a</i>	402	271,350
Widening Street at Approach to Portal				77,650
Contingencies for Existing Underground Structures				25,300
Right-of-Way				280,000
				Total \$4,400,000

SUMMARY OF ESTIMATES OF COST

Washington Street Subway

A two-track subway along Washington Street from a terminal loop in Grant Park east of Michigan Avenue to a connection with the existing Washington Street tunnel under the Chicago River west of Franklin Street.

Changes to Existing River Tunnel				\$ 61,400
High Level Subway—between Stations	173 Lin. Ft.	@	\$ 992	171,616
High Level Subway—with Side Platforms	2,195 Lin. Ft.	@	1,328	2,914,960
Typical High Level Subway Stations	7 Each	@	225,000	1,575,000
Grant Park Loop and Station including Pedestrian Subway to I. C. R. R.				409,600
Pedestrian Subway to State Street and Dearborn Street Subways				133,200
Contingencies for Existing Underground Structures				134,224
				Total \$5,400,000

Jackson Street Subway

A two-track subway along Jackson Street and Franklin Street from a terminal loop in Grant Park east of Michigan Avenue to a connection with the existing Van Buren Street tunnel under the Chicago River west of Franklin Street.

Changes to Existing River Tunnel				\$ 111,100
High Level Subway—between Stations	950 Lin. Ft.	@	\$ 992	942,400
High Level Subway—with Side Platforms	2,195 Lin. Ft.	@	1,328	2,914,960
Typical High Level Subway Stations	7 Each	@	225,000	1,575,000
Grant Park Loop and Station including Pedestrian Subway to I. C. R. R.				453,975
Pedestrian Subway to State Street and Dearborn Street Subways				133,200
Contingencies for Existing Underground Structures				169,365
				Total \$6,300,000

ESTIMATED COSTS PER LINEAL FOOT

Two-Track—High Level Subway—Section Between Stations

Excavation	38.5	Cu. Yds.	@	\$ 7.50	\$ 288.75
Steel Sheet Piling	1.1	Tons	@	80.00	88.00
Decking and Shoring	1.1	M.B.M.	@	100.00	110.00
Concrete	6.9	Cu. Yds.	@	15.00	103.50
Structural Steel	0.08	Tons	@	130.00	10.40
Structural Steel	0.02	Tons	@	110.00	2.20
Reinforcing Steel	0.64	Tons	@	70.00	44.80
Sand Backfill	17.6	Cu. Yds.	@	2.00	35.20
Paving	6.7	Sq. Yds.	@	3.50	23.45
Other Items					87.70
Engineering, Overhead and Contingencies—25%					198.00
					Total \$ 992.00

ESTIMATED COSTS PER LINEAL FOOT

Two-Track—High Level Subway—With Side Platforms

Excavation	5.2	Cu. Yds.	at \$ 7.50	\$ 390.00
Steel Sheet Piling	1.2	Tons	at 80.00	96.00
Decking and Shoring	1.1	M.B.M.	at 100.00	110.00
Concrete—Walls, Floor, Roof	10.5	Cu. Yds.	at 15.00	157.50
Concrete—Platforms, Beams	1.1	Cu. Yds	at 18.00	19.80
Structural Steel	0.121	Tons	at 130.00	15.73
Structural Steel	0.06	Tons	at 110.00	6.60
Reinforcing Steel	1.24	Tons	at 70.00	86.80
Waterproofing	5.76	Sq. Yds.	at 2.50	14.40
Sand Backfill	17.7	Cu. Yds.	at 2.00	35.40
Paving	6.7	Sq. Yds.	at 3.50	23.45
Other Items				106.32
Engineering, Overhead and Contingencies—25%				266.00
				<hr/>
			Total	\$1,328.00

Single Track Tunnel—Between Stations

Excavation	13.68	Cu. Yds.	at \$ 7.50	\$ 102.60
Concrete	5.52	Cu. Yds.	at 18.00	99.36
Reinforcing Steel	0.28	Tons	at 70.00	19.60
Liner Plates	0.41	Tons	at 120.00	49.20
Other Items				30.24
Engineering, Overhead and Contingencies—25%				75.00
				<hr/>
			Total	\$ 376.00

Two-Track Tunnel with 18 Foot Center Platform

Excavation	40.65	Cu. Yds.	at \$ 7.50	\$ 304.88
Concrete—Walls, Floor, Roof	13.77	Cu. Yds.	at 18.00	247.86
Concrete—Platform	1.00	Cu. Yds.	at 21.00	21.00
Structural Steel	0.50	Tons	at 110.00	55.00
Reinforcing Steel	0.80	Tons	at 70.00	56.00
Liner Plates and Ribs	1.24	Tons	at 120.00	148.80
Other Items				66.46
Engineering, Overhead and Contingencies—25%				225.00
				<hr/>
			Total	\$1,125.00

ESTIMATED COSTS

Typical Mezzanine Station

Excavation	5,600	Cu. Yds.	@ \$ 7.50	\$ 42,000
Steel Sheet Piling	190	Tons	@ 80.00	15,200
Decking and Shoring	76.5	M.B.M.	@ 100.00	7,650
Concrete	940	Cu. Yds.	@ 15.00	14,100
Structural Steel	26	Tons	@ 110.00	2,860
Reinforcing Steel	75	Tons	@ 70.00	5,250
Stairs, Escalators and Platform Finish				147,915
Waterproofing	690	Sq. Yds.	@ 2.50	1,725
Sand Backfill	1,900	Cu. Yds.	@ 2.00	3,800
Paving	560	Sq. Yds.	@ 3.50	1,960
Curb and Gutter	240	Lin. Ft.	@ 1.50	360
Sidewalks	4,800	Sq. Ft.	@ 0.35	1,680
Other Items				13,500
Engineering, Overhead and Contingencies—25%				64,000
				<hr/>
			Total	\$322,000

*Typical High Level Subway Station with Side Platforms
(52 Feet Long—Including Track Section)*

Excavation	5,950	Cu. Yds.	@ \$ 7.50	\$ 44,625
Steel Sheet Piling	90	Tons	@ 80.00	7,200
Decking and Shoring	113	M.B.M.	@ 100.00	11,300
Concrete	1,675	Cu. Yds.	@ 15.00	25,125
Structural Steel	17.2	Tons	@ 110.00	1,892
Reinforcing Steel	192	Tons	@ 70.00	13,440
Finish and Stairs, etc.				55,500
Waterproofing	830	Sq. Yds.	@ 2.50	2,075
Sand Backfill	2,590	Cu. Yds.	@ 2.00	5,180
Paving	630	Sq. Yds.	@ 3.50	2,205
Curbs and Gutters	380	Lin. Ft.	@ 1.50	570
Sidewalks	6,300	Sq. Ft.	@ 0.35	2,205
Other Items				8,683
Engineering, Overhead and Contingencies—25%				45,000
				<hr/>
			Total	\$225,000

ESTIMATED COSTS PER LINEAL FOOT

*Single Track Tunnel—Between Stations
(In Difficult Ground Conditions)*

Excavation	17.34	Cu. Yds.	@	\$ 7.50	\$ 130.05
Concrete	6.11	Cu. Yds.	@	18.00	109.98
Reinforcing Steel	0.242	Tons	@	70.00	16.94
Primary Lining	2.27	Tons	@	100.00	227.00
Other Items					40.03
Engineering, Overhead and Contingencies—25%					131.00
					Total \$ 655.00

*Two-Track Tunnel—With 22 Foot Center Platform
(In Difficult Ground Conditions)*

Excavation	40.9	Cu. Yds.	@	\$ 7.50	\$ 306.75
Concrete	13.82	Cu. Yds.	@	18.00	248.76
Structural Steel	0.466	Tons	@	110.00	51.26
Reinforcing Steel	0.554	Tons	@	70.00	38.78
Primary Lining	4.5	Tons	@	100.00	450.00
Other Items					75.45
Engineering, Overhead and Contingencies—25%					293.00
					Total \$1,464.00

WEST SIDE SUPERHIGHWAY—SUMMARY OF ESTIMATE OF COST

*West Side Superhighway**Michigan Avenue to State Street (Roadway Widening Only)*

Excavation, Special	2,000 Cu. Yds.	@	\$ 1.50	\$ 3,000
Pavement	5,500 Sq. Yds	@	3.50	19,250
Granite Block Pavement	30 Sq. Yds.	@	10.00	300
Curb and Gutter	2,000 Lin. Ft.	@	1.00	2,000
Sidewalk	7,000 Sq. Ft.	@	0.25	1,750
Concrete	1,500 Cu. Yds.	@	30.00	45,000
Reinforcing Steel	225,000 Lbs.	@	0.045	10,125
Gravel Backfill	750 Cu. Yds.	@	2.50	1,875
Catch Basins	16 Each	@	80.00	1,280
8" Sewer	500 Lin. Ft.	@	1.50	750
Trench Backfill	200 Cu. Yds.	@	1.50	300
Lighting				5,500
Adjusting City Owned Underground Utilities				6,000
Engineering, Legal and Administrative Costs				6,800
Contingencies				16,070

Total Cost of Section \$ 120,000

State Street to Clark Street

Fill	15,000 Cu. Yds.	@	\$ 1.00	\$ 15,000
Excavation, Special	1,000 Cu. Yds.	@	1.50	1,500
Pavement	8,000 Sq. Yds.	@	3.50	28,000
Granite Block Pavement	60 Sq. Yds.	@	10.00	600
Curb and Gutter	3,000 Lin. Ft.	@	1.00	3,000
Sidewalk	25,000 Sq. Ft.	@	0.25	6,250
Catch Basins	40 Each	@	80.00	3,200
Manholes	4 Each	@	70.00	280
8" Sewer	1,000 Lin. Ft.	@	1.50	1,500
12" Sewer	900 Lin. Ft.	@	2.25	2,025
Trench Backfill	1,000 Cu. Yds.	@	1.50	1,500
Lighting				5,500
Adjusting City Owned Underground Utilities				9,000
Engineering, Legal and Administrative Costs				5,400
Contingencies				7,245
				Total Construction Cost \$ 90,000
Land and Buildings				1,550,000
				Total Cost of Section \$1,640,000

Clark Street to Wells Street

Fill	10,000 Cu. Yds.	@	\$ 1.00	\$ 10,000
Excavation, Special	2,000 Cu. Yds.	@	1.50	3,000
Pavement	10,000 Sq. Yds.	@	3.50	35,000
Granite Block Pavement	210 Sq. Yds.	@	10.00	2,100
Curb and Gutter	4,000 Lin. Ft.	@	1.00	4,000
Sidewalk	17,500 Sq. Ft.	@	0.25	4,375
Catch Basins	36 Each	@	80.00	2,880
Manholes	4 Each	@	70.00	280
8" Sewer	900 Lin. Ft.	@	1.50	1,350
12" Sewer	600 Lin. Ft.	@	2.25	1,350
Trench Backfill	800 Cu. Yds.	@	1.50	1,200
Lighting				5,000
Adjusting City Owned Underground Utilities				10,000
Construction under La Salle Street Station and Provision of Substitute Railroad Facilities				1,750,000
Engineering, Legal and Administrative Costs				128,000
Contingencies				251,465
				Total Construction Cost \$2,210,000
Land and Buildings				1,030,000
				Total Cost of Section \$3,240,000

Wells Street to the Chicago River

Fill	18,000 Cu. Yds.	@	\$ 1.00	\$ 18,000
Excavation, Special	1,500 Cu. Yds.	@	1.50	2,250
Pavement	12,000 Sq. Yds.	@	3.50	42,000
Curb and Gutter	7,500 Lin. Ft.	@	1.00	7,500
Sidewalk	9,000 Sq. Ft.	@	0.25	2,250
Concrete	900 Cu. Yds.	@	30.00	27,000
Reinforcing Steel	135,000 Lbs.	@	0.045	6,075
Hand-rail	1,500 Lin. Ft.	@	6.00	9,000
Gravel Backfill	500 Cu. Yds.	@	2.50	1,250
Catch Basins	36 Each	@	80.00	2,880
Manholes	4 Each	@	70.00	280
8" Sewer	1,100 Lin. Ft.	@	1.50	1,650
Trench Backfill	500 Cu. Yds.	@	1.50	750
Granite Block Pavement	40 Sq. Yds.	@	10.00	400
Lighting				8,000
Adjusting City Owned Underground Utilities				3,000
Landscaping				5,000
Market Street Bridge				97,000
Franklin Street Bridge				121,000
Engineering, Legal and Administrative Costs				24,900
Contingencies				49,815
				Total Construction Cost \$ 430,000
Land and Buildings				1,750,000
				Total Cost of Section \$2,180,000

Chicago River Bridge

\$1,350,000

Total Cost of Section \$1,350,000*Canal Street to Desplaines Street*

Fill	14,000 Cu. Yds.	@	\$ 1.00	\$ 14,000
Excavation, Special	7,500 Cu. Yds.	@	1.50	11,250
Pavement	27,000 Sq. Yds.	@	3.50	94,500
Curb and Gutter	9,500 Lin. Ft.	@	1.00	9,500
Sidewalk	14,000 Sq. Ft.	@	0.25	3,500
Concrete Retaining Walls	700 Cu. Yds.	@	30.00	21,000
Concrete Deck Slab	4,750 Cu. Yds.	@	22.00	104,500
Reinforcing Steel	1,000,000 Lbs.	@	0.045	45,000
Structural Steel	3,000 Tons	@	125.00	375,000
Steel Castings	100 Tons	@	400.00	40,000
Hand-rail	3,850 Lin. Ft.	@	6.00	23,100
Gravel Backfill	350 Cu. Yds.	@	2.50	875
Piling	13,500 Lin. Ft.	@	2.50	33,750
Drainage of Structure				6,000
Catch Basins	36 Each	@	80.00	2,880
Manholes	5 Each	@	70.00	350
8" Sewer	1,000 Lin. Ft.	@	1.50	1,500
12" Sewer	1,200 Lin. Ft.	@	2.25	2,700
Trench Backfill	1,200 Cu. Yds.	@	1.50	1,800
Granite Block Pavement	310 Sq. Yds.	@	10.00	3,100
Lighting, Upper and Lower Level				25,000
Adjusting City Owned Underground Utilities				6,000
Engineering, Legal and Administrative Costs				57,800
Contingencies				116,895

Total Construction Cost \$1,000,000

Land and Buildings

710,000

Total Cost of Section \$1,710,000

Desplaines Street to Throop Street

Fill	220,000 Cu. Yds.	@	\$ 1.00	\$ 220,000
Excavation, Special	6,000 Cu. Yds.	@	1.50	9,000
Pavement	68,000 Sq. Yds.	@	3.50	238,000
Curb and Gutter	32,000 Lin. Ft.	@	1.00	32,000
Sidewalk	5,000 Sq. Ft.	@	0.25	1,250
Concrete	14,600 Cu. Yds.	@	30.00	438,000
Reinforcing Steel	2,175,000 Lbs.	@	0.045	97,875
Gravel Backfill	7,300 Cu. Yds.	@	2.50	18,250
Hand-rail	8,400 Lin. Ft.	@	6.00	50,400
Catch Basins	128 Each	@	80.00	10,240
Manholes	17 Each	@	70.00	1,190
8" Sewer	3,400 Lin. Ft.	@	1.50	5,100
12" Sewer	3,500 Lin. Ft.	@	2.25	7,875
Trench Backfill	3,600 Cu. Yds.	@	1.50	5,400
Lighting				46,000
Adjusting City Owned Underground Utilities				21,000
Racine Avenue Bridge				59,000
Aberdeen Street Bridge				54,000
Morgan Street Bridge				59,000
Sangamon Street Bridge				54,000
Peoria Street Bridge				54,000
Green Street Bridge				54,000
Halsted Street Bridge				59,000
Engineering, Legal and Administrative Costs				111,600
Contingencies				223,820
				Total Construction Cost \$1,930,000
Land and Buildings				1,100,000
				Total Cost of Section \$3,030,000

Throop Street to Ashland Avenue

Excavation	108,000 Cu. Yds.	@ \$ 1.00	\$ 108,000
Pavement	25,000 Sq. Yds.	@ 3.50	87,500
Curb and Gutter	12,000 Lin. Ft.	@ 1.00	12,000
Sidewalk	2,500 Sq. Ft.	@ 0.25	625
Concrete	1,300 Cu. Yds.	@ 30.00	39,000
Reinforcing Steel	195,000 Lbs.	@ 0.045	8,775
Gravel Backfill	650 Cu. Yds.	@ 2.50	1,625
Catch Basins	70 Each	@ 80.00	5,600
Manholes	15 Each	@ 70.00	1,050
8" Sewer	1,800 Lin. Ft.	@ 1.50	2,700
12" Sewer	2,500 Lin. Ft.	@ 2.25	5,625
15" Sewer	600 Lin. Ft.	@ 2.60	1,560
18" Sewer	600 Lin. Ft.	@ 3.10	1,860
Trench Backfill	3,200 Cu. Yds.	@ 1.50	4,800
Pumping Stations	2 Each	@ 3,500.00	7,000
Lighting			15,000
Landscaping and Fencing			23,000
Adjusting City Owned Underground Utilities			35,000
Ashland Avenue Bridge			96,000
Lafin Street Bridge			52,000
Loomis Street Bridge			52,000
Engineering, Legal and Administrative Costs			39,300
Contingencies			79,980
			Total Construction Cost \$ 680,000
Land and Buildings			320,000
			Total Cost of Section \$1,000,000

Ashland Avenue to Damen Avenue

Excavation	180,000 Cu. Yds.	@ \$ 1.00	\$ 180,000
Pavement	36,000 Sq. Yds.	@ 3.50	126,000
Curb and Gutter	15,000 Lin. Ft.	@ 1.00	15,000
Sidewalk	4,000 Sq. Ft.	@ 0.25	1,000
Concrete	1,750 Cu. Yds.	@ 30.00	52,500
Reinforcing Steel	262,000 Lbs.	@ 0.045	11,790
Gravel Backfill	900 Cu. Yds.	@ 2.50	2,250
Catch Basins	78 Each	@ 80.00	6,240
Manholes	15 Each	@ 70.00	1,050
8" Sewer	2,000 Lin. Ft.	@ 1.50	3,000
12" Sewer	1,100 Lin. Ft.	@ 2.25	2,475
15" Sewer	800 Lin. Ft.	@ 2.60	2,080
18" Sewer	800 Lin. Ft.	@ 3.10	2,480
Trench Backfill	2,500 Cu. Yds.	@ 1.50	3,750
Pumping Stations	2 Each	@ 4,000.00	8,000
Lighting			21,000
Landscaping and Fencing			45,000
Adjusting City Owned Underground Utilities			67,000
Damen Avenue Bridges (2)			125,000
Ogden Avenue Bridge			95,000
Wood Street Bridge			52,000
Paulina Street Bridge			73,000
Chicago Rapid Transit Bridges (2)			475,000
Engineering, Legal and Administrative Costs			95,900
Contingencies			193,485
		Total Construction Cost	\$1,660,000
Land and Buildings			575,000
		Total Cost of Section	\$2,235,000

Damen Avenue to Western Avenue

Excavation	165,000 Cu. Yds.	@ \$ 1.00	\$ 165,000
Pavement	37,000 Sq. Yds.	@ 3.50	129,500
Curb and Gutter	15,500 Lin. Ft.	@ 1.00	15,500
Sidewalk	2,500 Sq. Ft.	@ 0.25	625
Concrete	2,000 Cu. Yds.	@ 30.00	60,000
Reinforcing Steel	300,000 Lbs.	@ 0.045	13,500
Gravel Backfill	1,000 Cu. Yds.	@ 2.50	2,500
Catch Basins	82 Each	@ 80.00	6,560
Manholes	18 Each	@ 70.00	1,260
8" Sewer	2,000 Lin. Ft.	@ 1.50	3,000
12" Sewer	1,700 Lin. Ft.	@ 2.25	3,825
15" Sewer	800 Lin. Ft.	@ 2.60	2,080
18" Sewer	800 Lin. Ft.	@ 3.10	2,480
Trench Backfill	3,000 Cu. Yds.	@ 1.50	4,500
Pumping Stations	2 Each	@ 4,000.00	8,000
Lighting			22,000
Landscaping and Fencing			35,000
Adjusting City Owned Underground Utilities			43,000
Western Avenue Bridge			111,000
Oakley Boulevard Bridge			63,000
Leavitt Street Bridge			41,000
Engineering, Legal and Administrative Costs			51,300
Contingencies			105,370
			Total Construction Cost \$ 890,000
Land and Buildings			560,000
			Total Cost of Section \$1,450,000

Western Avenue to California Avenue

Excavation	147,000 Cu. Yds.	@	\$ 1.00	\$ 147,000
Pavement	32,000 Sq. Yds.	@	3.50	112,000
Curb and Gutter	14,000 Lin. Ft.	@	1.00	14,000
Sidewalk	2,500 Sq. Ft.	@	0.25	625
Concrete	1,600 Cu. Yds.	@	30.00	48,000
Reinforcing Steel	240,000 Lbs.	@	0.045	10,800
Gravel Backfill	1,600 Cu. Yds.	@	2.50	4,000
Catch Basins	88 Each	@	80.00	7,040
Manholes	22 Each	@	70.00	1,540
8" Sewer	2,500 Lin. Ft.	@	1.50	3,750
12" Sewer	3,000 Lin. Ft.	@	2.25	6,750
15" Sewer	800 Lin. Ft.	@	2.60	2,080
18" Sewer	800 Lin. Ft.	@	3.10	2,480
Trench Backfill	4,000 Cu. Yds.	@	1.50	6,000
Pumping Stations	2 Each	@	4,000.00	8,000
Lighting				19,000
Landscaping and Fencing				31,000
Adjusting City Owned Underground Utilities				42,000
California Avenue Bridge				63,000
Washtenaw Avenue Bridge				41,000
C. & N. W. Railroad Bridge				210,000
Campbell Avenue Bridge				52,000
Engineering, Legal and Administrative Costs				58,200
Contingencies				119,735
				Total Construction Cost \$1,010,000
Land and Buildings				560,000
				Total Cost of Section \$1,570,000

California Avenue to Kedzie Avenue

Excavation	164,000 Cu. Yds.	@	\$ 1.00	\$ 164,000
Pavement	36,000 Sq. Yds.	@	3.50	126,000
Curb and Gutter	16,000 Lin. Ft.	@	1.00	16,000
Sidewalk	3,500 Sq. Ft.	@	0.25	875
Concrete	550 Cu. Yds.	@	30.00	16,500
Reinforcing Steel	83,000 Lbs.	@	0.045	3,735
Gravel Backfill	300 Cu. Yds.	@	2.50	750
Catch Basins	68 Each	@	80.00	5,440
Manholes	14 Each	@	70.00	980
8" Sewer	1,800 Lin. Ft.	@	1.50	2,700
12" Sewer	900 Lin. Ft.	@	2.25	2,025
15" Sewer	800 Lin. Ft.	@	2.60	2,080
18" Sewer	800 Lin. Ft.	@	3.10	2,480
Trench Backfill	2,400 Cu. Yds.	@	1.50	3,600
Pumping Stations	2 Each	@	4,000.00	8,000
Lighting				21,000
Landscaping and Fencing				57,000
Adjusting City Owned Underground Utilities				33,000
Kedzie Avenue Bridge				73,000
Sacramento Boulevard Bridge				63,000
Engineering, Legal and Administrative Costs				42,200
Contingencies				85,635
				Total Construction Cost \$ 730,000
Land and Buildings				700,000
				Total Cost of Section \$1,430,000

Kedzie Avenue to Central Park Avenue

Excavation	164,000 Cu. Yds.	@	\$ 1.00	\$ 164,000
Pavement	30,000 Sq. Yds.	@	3.50	105,000
Curb and Gutter	12,000 Lin. Ft.	@	1.00	12,000
Sidewalk	4,000 Sq. Ft.	@	0.25	1,000
Catch Basins	60 Each	@	80.00	4,800
Manholes	14 Each	@	70.00	980
8" Sewer	1,700 Lin. Ft.	@	1.50	2,550
12" Sewer	800 Lin. Ft.	@	2.25	1,800
15" Sewer	800 Lin. Ft.	@	2.60	2,080
18" Sewer	800 Lin. Ft.	@	3.10	2,480
Trench Backfill	2,200 Cu. Yds.	@	1.50	3,300
Pumping Stations	2 Each	@	4,000.00	8,000
Lighting				18,000
Landscaping and Fencing				73,000
Adjusting City Owned Underground Utilities				47,000
Central Park Avenue Bridge				63,000
Homan Avenue Bridge				63,000
Engineering, Legal and Administrative Costs				40,000
Contingencies				78,010
				Total Construction Cost \$ 690,000
Land and Buildings				960,000
				Total Cost of Section \$1,650,000

Central Park Avenue to Pulaski Road

Excavation	155,000 Cu. Yds.	@	\$ 1.00	\$ 155,000
Pavement	40,000 Sq. Yds.	@	3.50	140,000
Curb and Gutter	18,000 Lin. Ft.	@	1.00	18,000
Sidewalk	6,000 Sq. Ft.	@	0.25	1,500
Catch Basins	80 Each	@	80.00	6,400
Manholes	14 Each	@	70.00	980
8" Sewer	1,800 Lin. Ft.	@	1.50	2,700
12" Sewer	1,300 Lin. Ft.	@	2.25	2,925
15" Sewer	800 Lin. Ft.	@	2.60	2,080
18" Sewer	800 Lin. Ft.	@	3.10	2,480
Trench Backfill	3,000 Cu. Yds.	@	1.50	4,500
Pumping Stations	2 Each	@	4,000.00	8,000
Lighting				24,000
Landscaping and Fencing				69,000
Adjusting City Owned Underground Utilities				49,000
Pulaski Road Bridge				73,000
Independence Boulevard Bridge				52,000
Hamlin Avenue Bridge				52,000
Fifth Avenue Bridge				107,000
Engineering, Legal and Administrative Costs				53,900
Contingencies				105,535
				<hr/>
			Total Construction Cost	\$ 930,000
Land and Buildings				1,000,000
				<hr/>
			Total Cost of Section	\$1,930,000

Palaski Road to Kostner Avenue

Excavation	163,000 Cu. Yds.	@	\$ 1.00	\$ 163,000
Pavement	30,000 Sq. Yds.	@	3.50	105,000
Curb and Gutter	12,000 Lin. Ft.	@	1.00	12,000
Sidewalk	3,500 Sq. Ft.	@	0.25	875
Catch Basins	56 Each	@	80.00	4,480
Manholes	15 Each	@	70.00	1,050
8" Sewer	1,600 Lin. Ft.	@	1.50	2,400
12 " Sewer	800 Lin. Ft.	@	2.25	1,800
15" Sewer	1,800 Lin. Ft.	@	2.60	4,680
18" Sewer	800 Lin. Ft.	@	3.10	2,480
Trench Backfill	2,900 Cu. Yds.	@	1.50	4,350
Pumping Stations	2 Each	@	4,000.00	8,000
Lighting				18,000
Landscaping and Fencing				71,000
Adjusting City Owned Underground Utilities				16,000
Kostner Avenue Bridge				63,000
Keeler Avenue Bridge				41,000
Engineering, Legal and Administrative Costs				36,300
Contingencies				74,585
				Total Construction Cost \$ 630,000
Land and Buildings				980,000
				Total Cost of Section \$1,610,000

Kostner Avenue to Cicero Avenue

Excavation	151,000 Cu. Yds.	@	\$ 1.00	\$ 151,000
Pavement	34,000 Sq. Yds.	@	3.50	119,000
Curb and Gutter	13,500 Lin. Ft.	@	1.00	13,500
Sidewalk	7,000 Sq. Ft.	@	0.25	1,750
Catch Basins	80 Each	@	80.00	6,400
Manholes	15 Each	@	70.00	1,050
8" Sewer	2,100 Lin. Ft.	@	1.50	3,150
12" Sewer	900 Lin. Ft.	@	2.25	2,025
15" Sewer	800 Lin. Ft.	@	2.60	2,080
18" Sewer	800 Lin. Ft.	@	3.10	2,480
Trench Backfill	2,600 Cu. Yds.	@	1.50	3,900
Pumping Stations	2 Each	@	4,000.00	8,000
Lighting				20,000
Landscaping and Fencing				64,000
Adjusting City Owned Underground Utilities				15,000
Cicero Avenue Bridge				73,000
Kilpatrick Avenue Bridge				52,000
Kilbourn Avenue Bridge				41,000
Belt Railway Bridge				130,000
Engineering, Legal and Administrative Costs				49,700
Contingencies				100,965
				Total Construction Cost \$ 860,000
Land and Buildings				96,000
				Total Cost of Section \$1,820,000

Cicero Avenue to Laramie Avenue

Excavation	164,000 Cu. Yds.	@	\$ 1.00	\$ 164,000
Pavement	35,000 Sq. Yds.	@	3.50	122,500
Curb and Gutter	15,000 Lin. Ft.	@	1.00	15,000
Sidewalk	4,000 Sq. Ft.	@	0.25	1,000
Catch Basins	78 Each	@	80.00	6,240
Manholes	15 Each	@	70.00	1,050
8" Sewer	2,000 Lin. Ft.	@	1.50	3,000
12" Sewer	1,200 Lin. Ft.	@	2.25	2,700
15" Sewer	800 Lin. Ft.	@	2.60	2,080
18" Sewer	800 Lin. Ft.	@	3.10	2,480
Trench Backfill	3,100 Cu. Yds.	@	1.50	4,650
Pumping Stations	2 Each	@	4,000.00	8,000
Lighting				21,000
Landscaping and Fencing				63,000
Adjusting City Owned Underground Utilities				16,000
Laramie Avenue Bridge				63,000
Lavergne Avenue Bridge				41,000
Engineering, Legal and Administrative Costs				37,600
Contingencies				75,700
				Total Construction Cost \$ 650,000
Land and Buildings				640,000
				Total Cost of Section \$1,290,000

Laramie Avenue to Central Avenue

Excavation	204,000 Cu. Yds.	at	\$ 1.00	\$ 204,000
Pavement	35,000 Sq. Yds.	at	3.50	122,500
Curb and Gutter	14,500 Lin. Ft.	at	1.00	14,500
Sidewalk	7,000 Sq. Ft.	at	0.25	1,750
Concrete	400 Cu. Yds.	at	30.00	12,000
Reinforcing Steel	60,000 Lbs.	at	0.045	2,700
Gravel Backfill	400 Cu. Yds.	at	2.50	1,000
Catch Basins	74 Each	at	80.00	5,920
Manholes	16	at	70.00	1,120
8" Sewer	1,800 Lin. Ft.	at	1.50	2,700
12" Sewer	900 Lin. Ft.	at	2.25	2,025
15" Sewer	800 Lin. Ft.	at	2.60	2,080
18" Sewer	800 Lin. Ft.	at	3.10	2,480
Trench Backfill	2,300 Cu. Yds.	at	1.50	3,450
Pumping Stations	2 Each	at	4,000.00	8,000
Lighting				21,000
Landscaping and Fencing				80,000
Adjusting City Owned Underground Utilities				15,000
Central Avenue Bridges (2)				58,000
Lotus Avenue Bridge				41,000
Engineering, Legal and Administrative Costs				42,100
Contingencies				86,675
				<hr/>
		Total Construction Cost	\$	730,000
Land and Buildings				990,000
				<hr/>
		Total Cost of Section	\$	1,720,000

Central Avenue to Austin Boulevard (Columbus Park)

Excavation	88,000 Cu. Yds.	at	\$ 1.00	\$ 88,000
Pavement	39,000 Sq. Yds.	at	3.50	136,500
Curb and Gutter	20,000 Lin. Ft.	at	1.00	20,000
Catch Basins	102 Each	at	80.00	8,160
Manholes	19 Each	at	70.00	1,330
8" Sewer	2,100 Lin. Ft.	at	1.50	3,150
12" Sewer	5,800 Lin. Ft.	at	2.25	13,050
Trench Backfill	4,700 Cu. Yds.	at	1.50	7,050
Pumping Station	1 Each	at	4,000.00	4,000
Lighting				27,000
Landscaping and Fencing				30,000
Adjusting City Owned Underground Utilities				5,000
Bridges in Columbus Park				66,000
Engineering, Legal and Administrative Costs				28,600
Contingencies				52,160
				<hr/>
		Total Cost of Section	\$	490,000

.

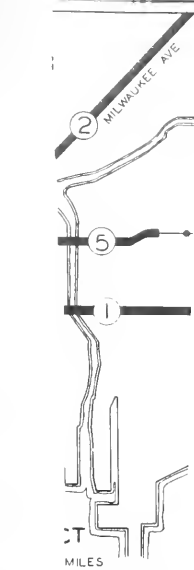
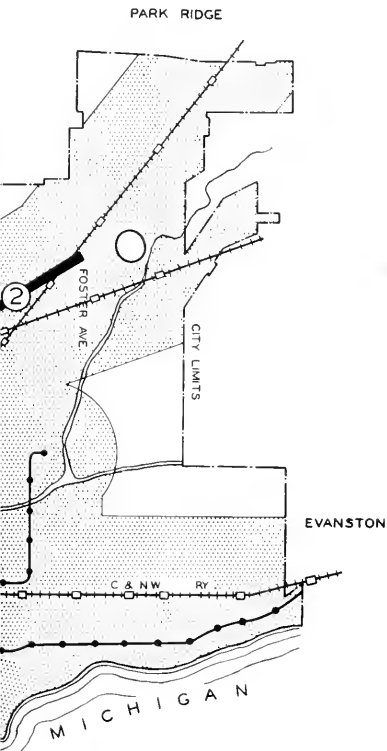
.

PROPOSED PATTERN CITY WIDE TRANSIT FACILITIES

CITY OF CHICAGO
DEPARTMENT OF SUBWAYS AND TRACTION

SEPTEMBER, 1939

0 1 2 MILES



COMPREHENSIVE PLAN
FOR THE
EXTENSION OF THE SUBWAY SYSTEM
SECOND STAGE



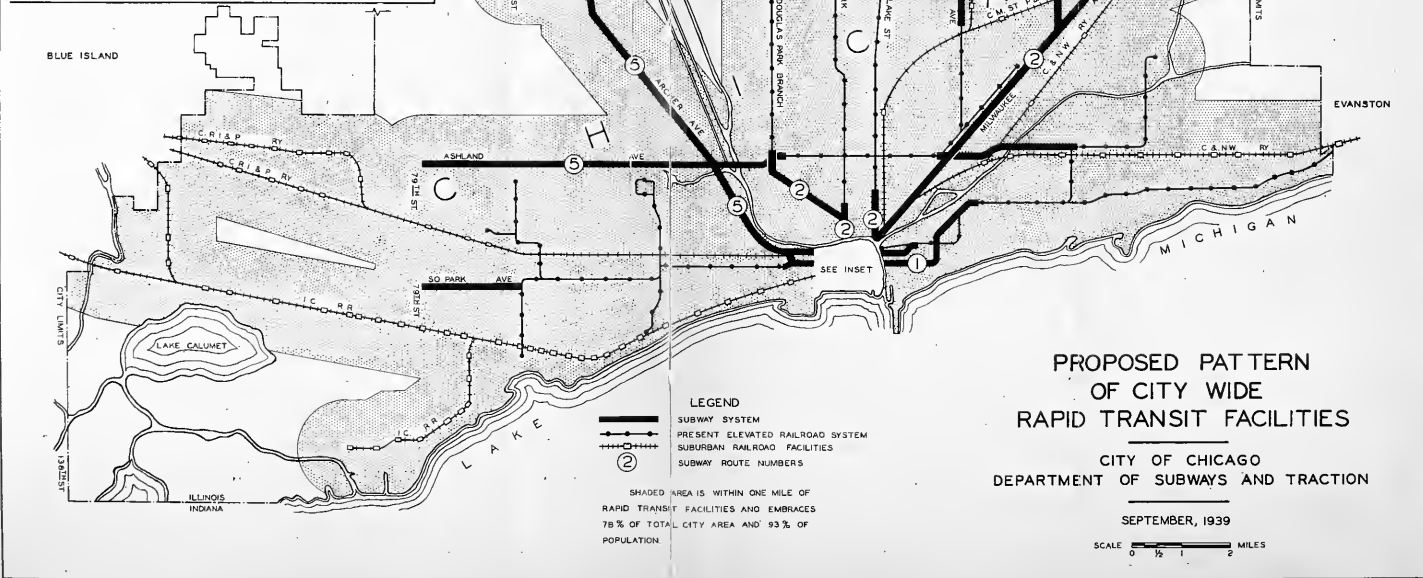
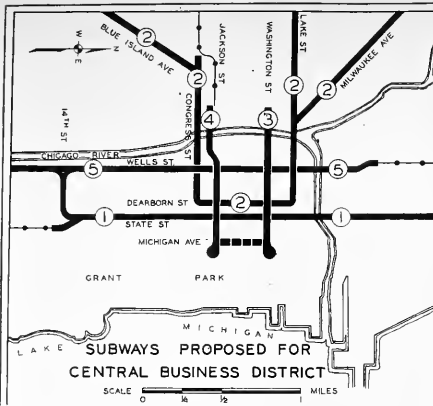
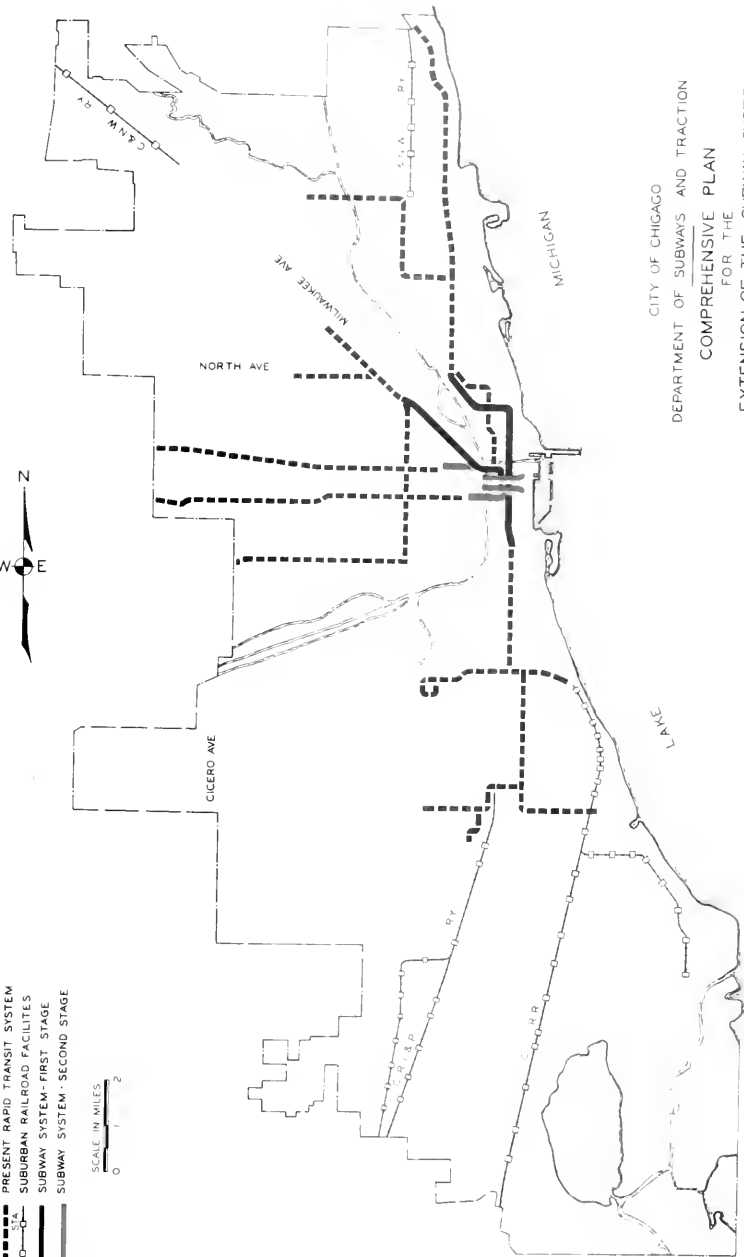


FIGURE A

- LEGEND**
- PRESENT RAPID TRANSIT SYSTEM
 - o- SUBURBAN RAILROAD FACILITIES
 - SUBWAY SYSTEM--FIRST STAGE
 - SUBWAY SYSTEM--SECOND STAGE

SCALE IN MILES
0 1 2



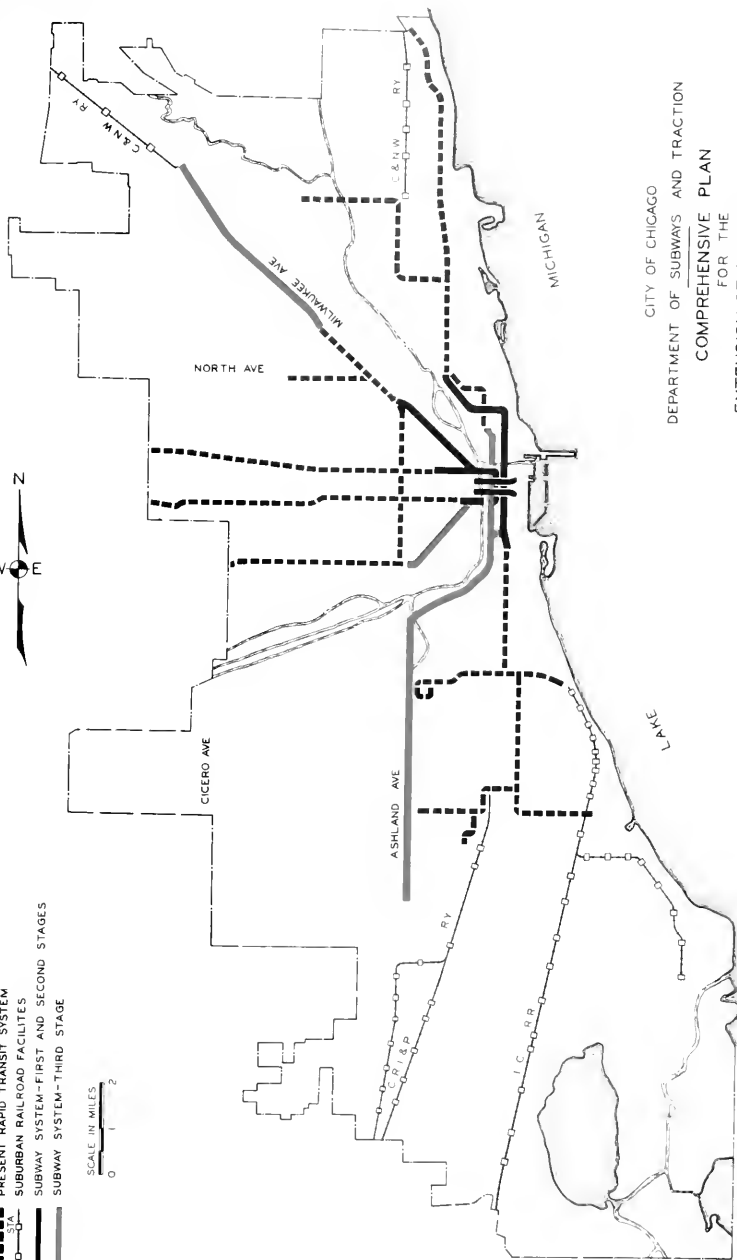
CITY OF CHICAGO
 DEPARTMENT OF SUBWAYS AND TRACTION
 COMPREHENSIVE PLAN
 FOR THE
 EXTENSION OF THE SUBWAY SYSTEM
 SECOND STAGE

FIGURE 2

LEGEND

- PRESENT RAPID TRANSIT SYSTEM
- o- SUBURBAN RAILROAD FACILITIES
- SUBWAY SYSTEM—FIRST AND SECOND STAGES
- SUBWAY SYSTEM—THIRD STAGE

SCALE IN MILES
0 1 2



CITY OF CHICAGO
DEPARTMENT OF SUBWAYS AND TRACTION
COMPREHENSIVE PLAN
FOR THE
EXTENSION OF THE SUBWAY SYSTEM
THIRD STAGE

FIGURE 3

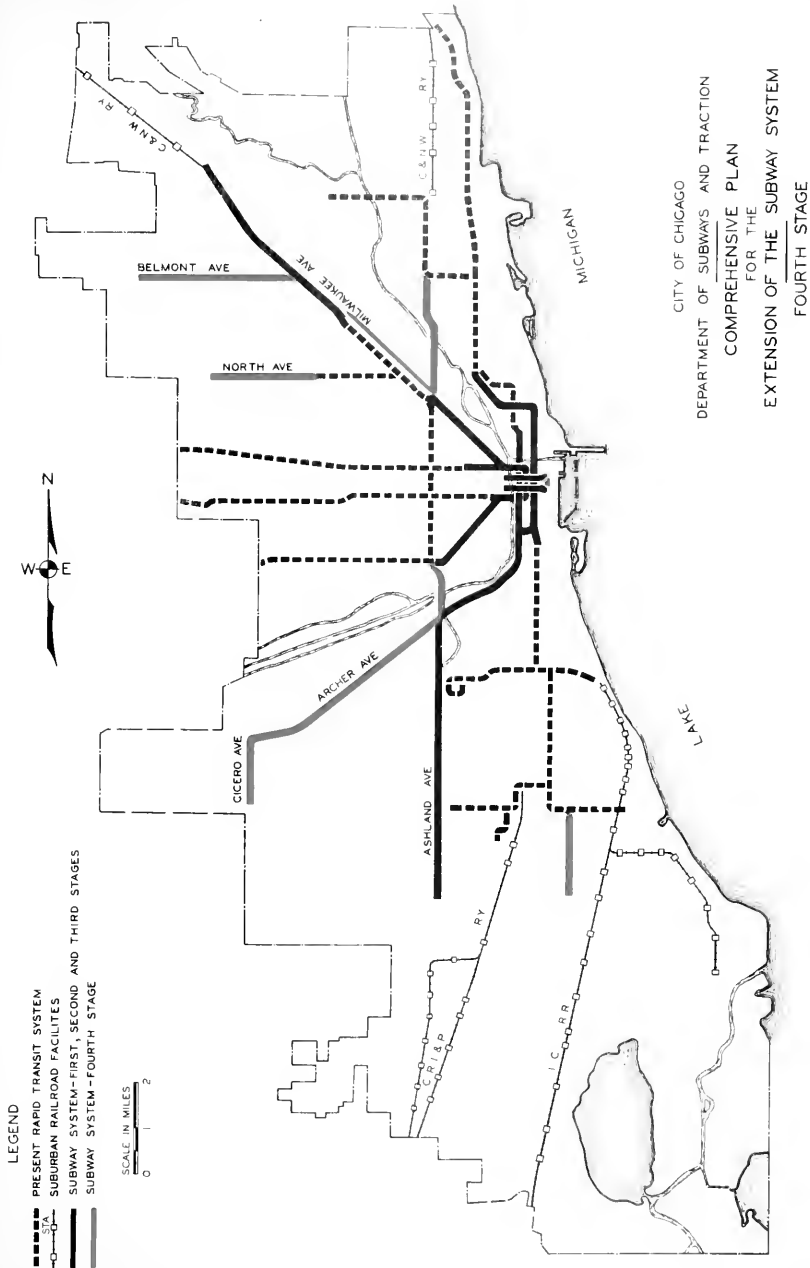
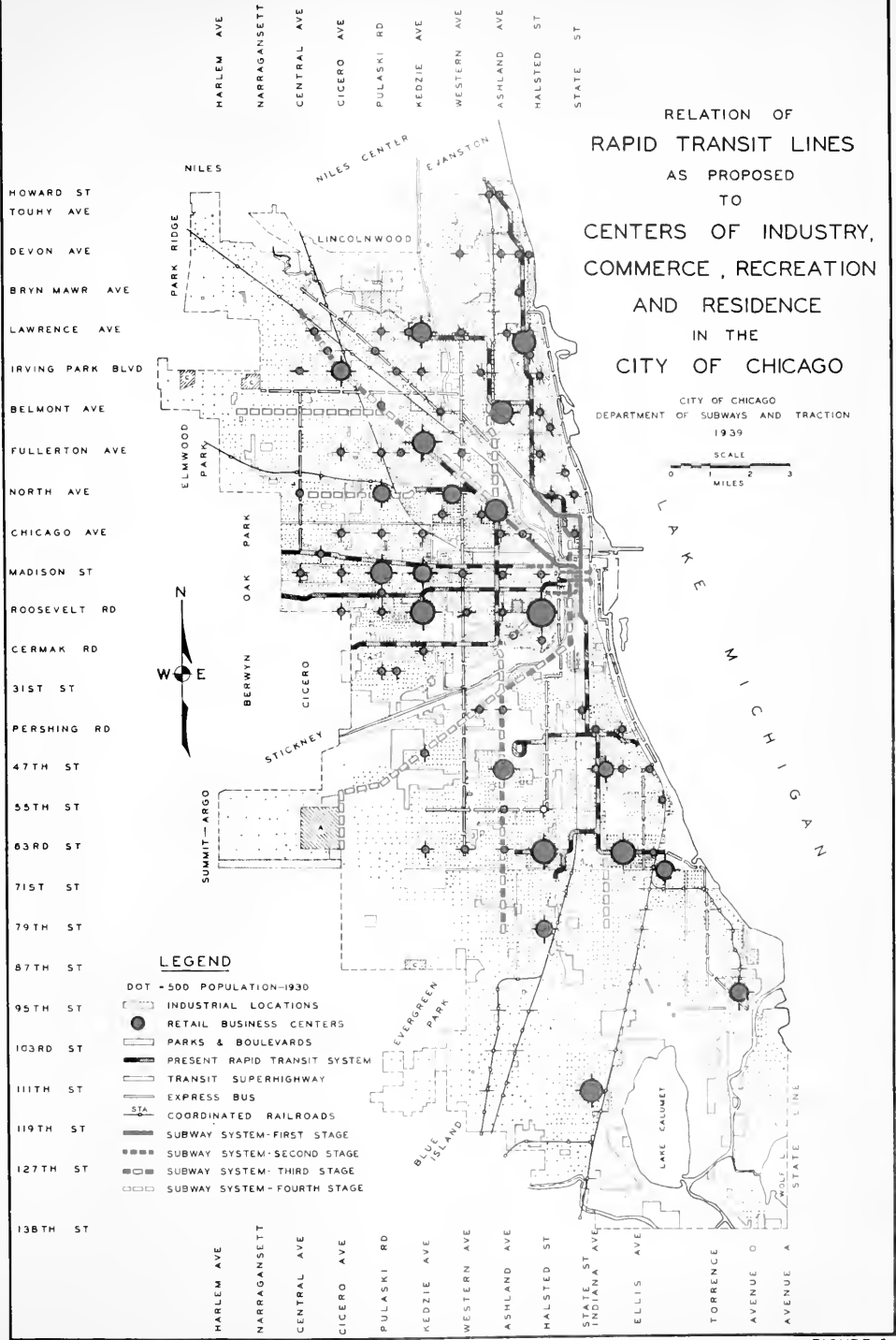


FIGURE 4

RELATION OF
 RAPID TRANSIT LINES
 AS PROPOSED
 TO
 CENTERS OF INDUSTRY,
 COMMERCE, RECREATION
 AND RESIDENCE
 IN THE
 CITY OF CHICAGO

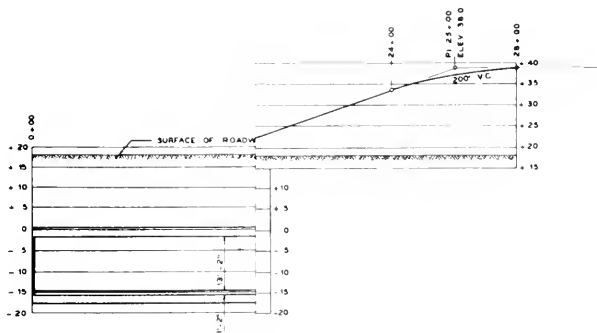
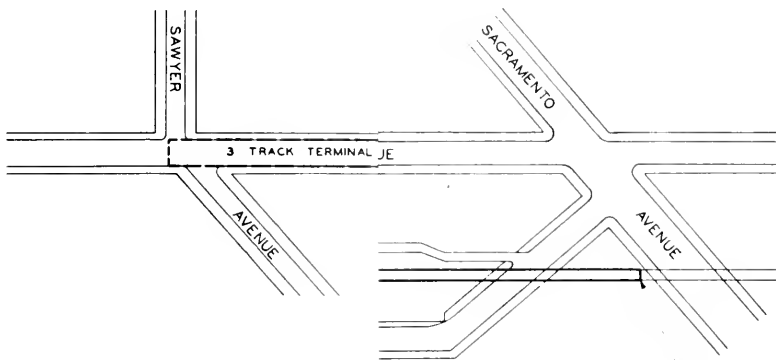
CITY OF CHICAGO
 DEPARTMENT OF SUBWAYS AND TRACTION
 1939
 SCALE
 0 1 2 3
 MILES



LEGEND

- DOT - 500 POPULATION-1930
- INDUSTRIAL LOCATIONS
- RETAIL BUSINESS CENTERS
- ▨ PARKS & BOULEVARDS
- PRESENT RAPID TRANSIT SYSTEM
- - - TRANSIT SUPERHIGHWAY
- EXPRESS BUS
- STA
- COORDINATED RAILROADS
- SUBWAY SYSTEM - FIRST STAGE
- SUBWAY SYSTEM - SECOND STAGE
- SUBWAY SYSTEM - THIRD STAGE
- SUBWAY SYSTEM - FOURTH STAGE

FIGURE 5

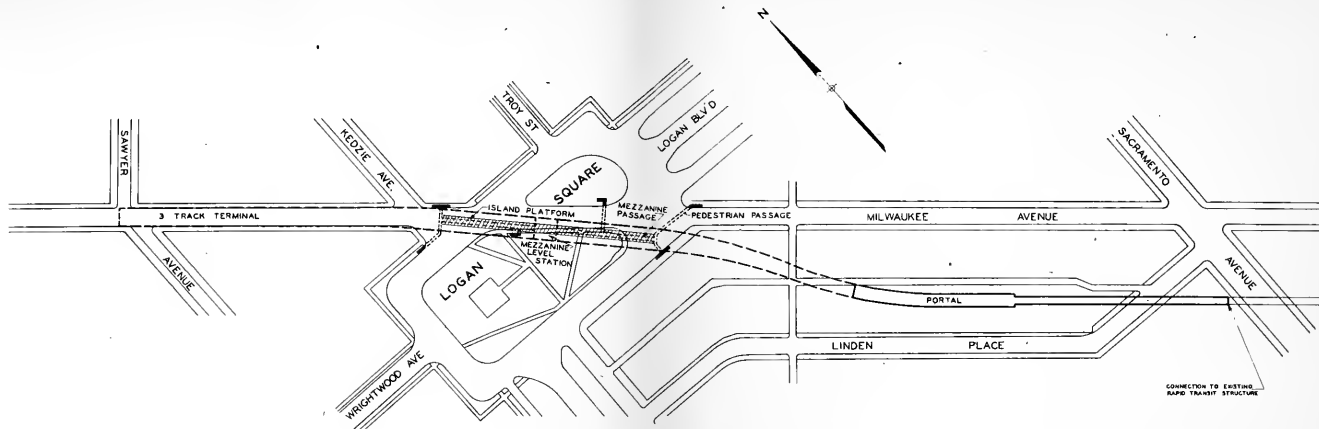


CITY OF CHICAGO
DEPARTMENT OF SUBWAYS AND TRACTION

PLAN AND PROFILE
PROPOSED SUBWAY TERMINAL AT
LOGAN SQUARE

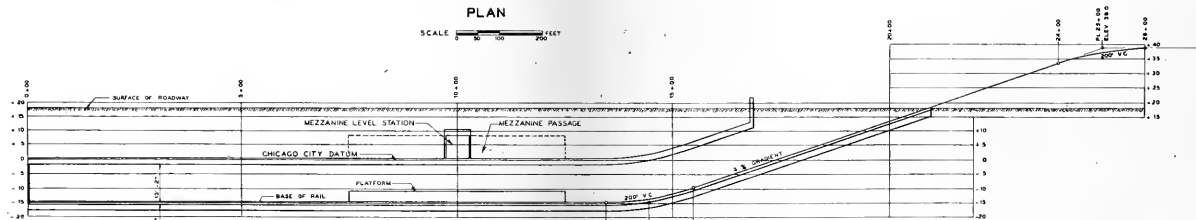
FILM 1937 REPORT TO
COMMITTEE ON LOCAL TRANSPORTATION

FIGURE 6



PLAN

SCALE 1" = 100 FEET



PROFILE

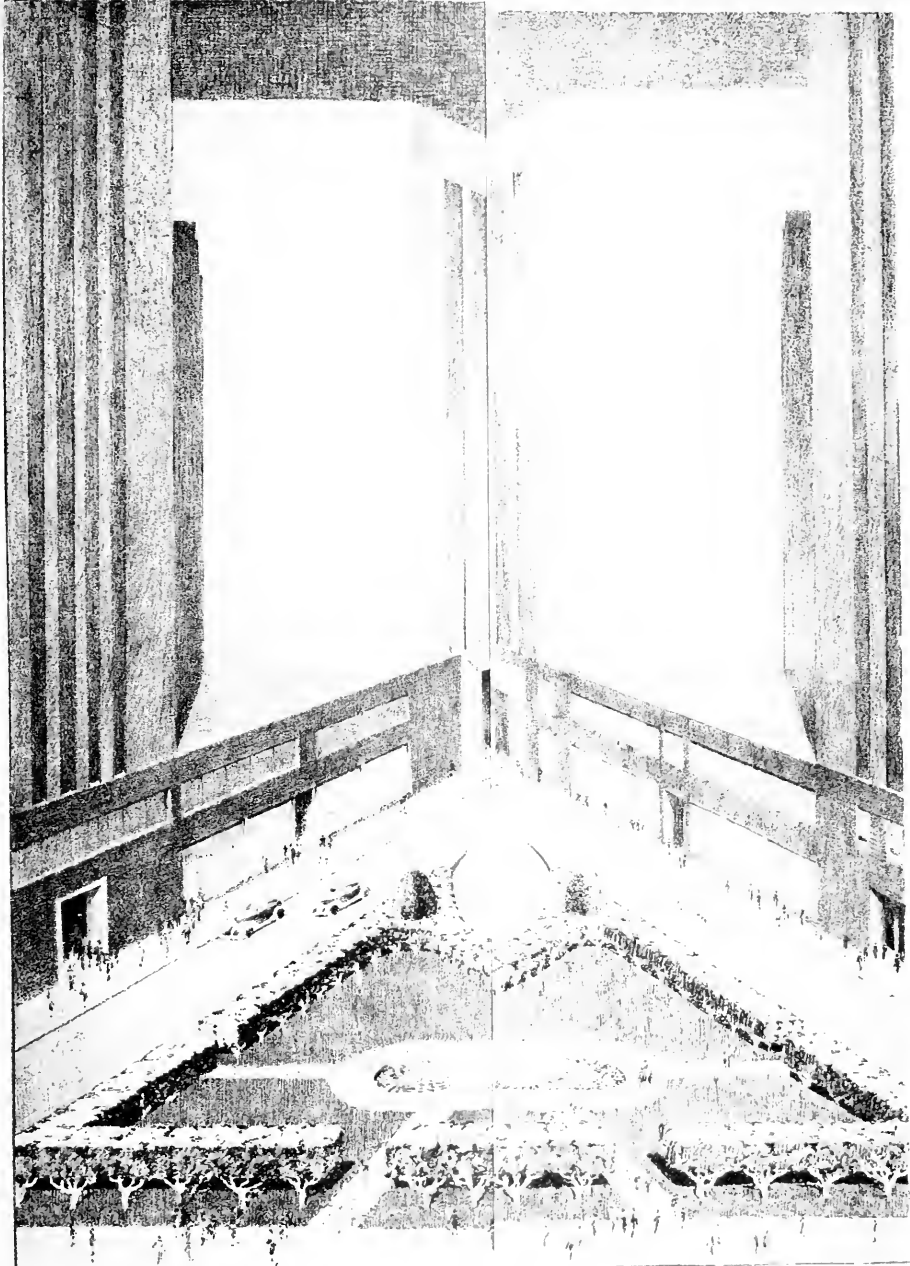
HORIZONTAL SCALE 1" = 25 FEET
 VERTICAL SCALE 1" = 5 FEET

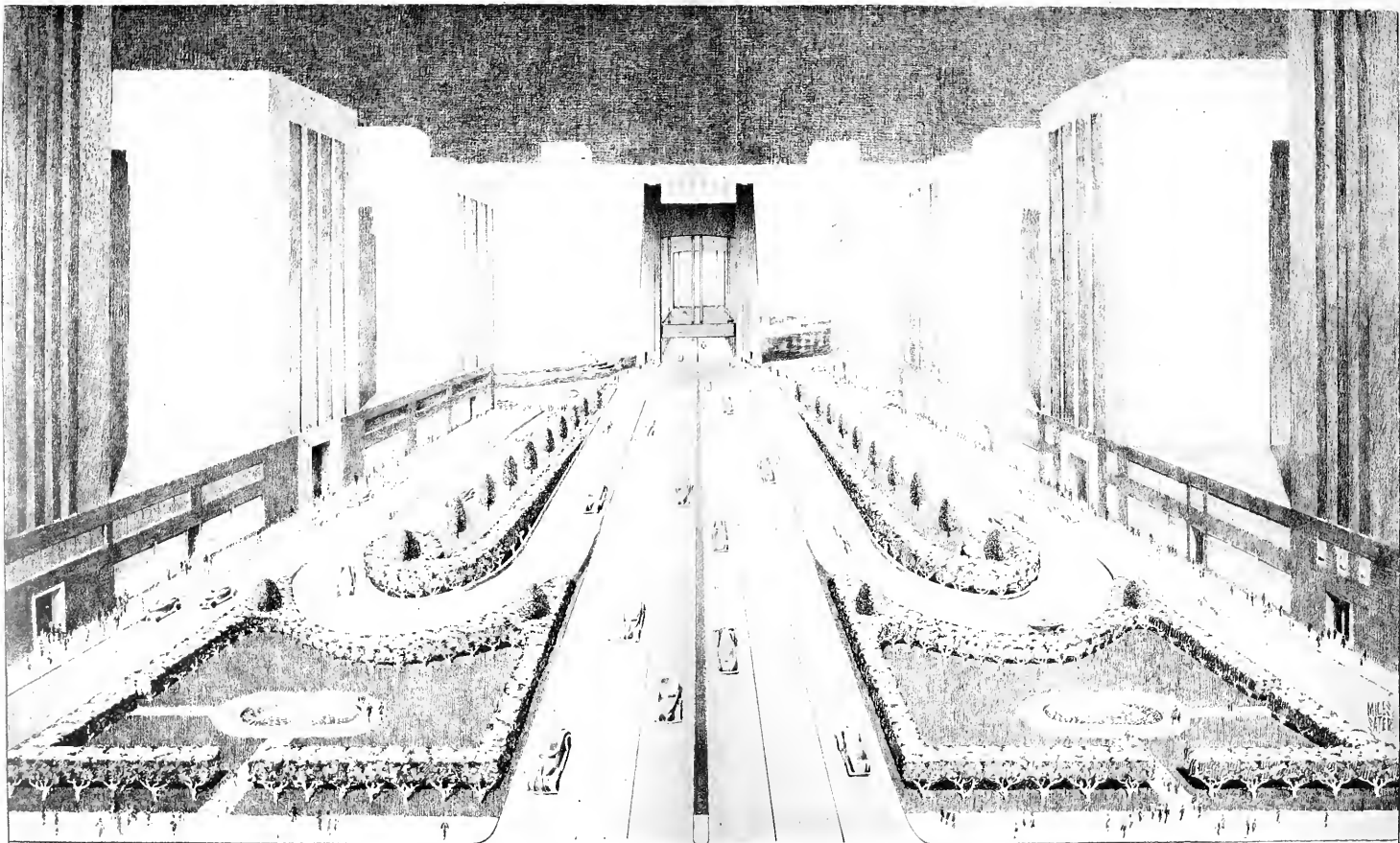
CITY OF CHICAGO
 DEPARTMENT OF SUBWAYS AND TRACTION

PLAN AND PROFILE
 PROPOSED SUBWAY TERMINAL AT
 LOGAN SQUARE

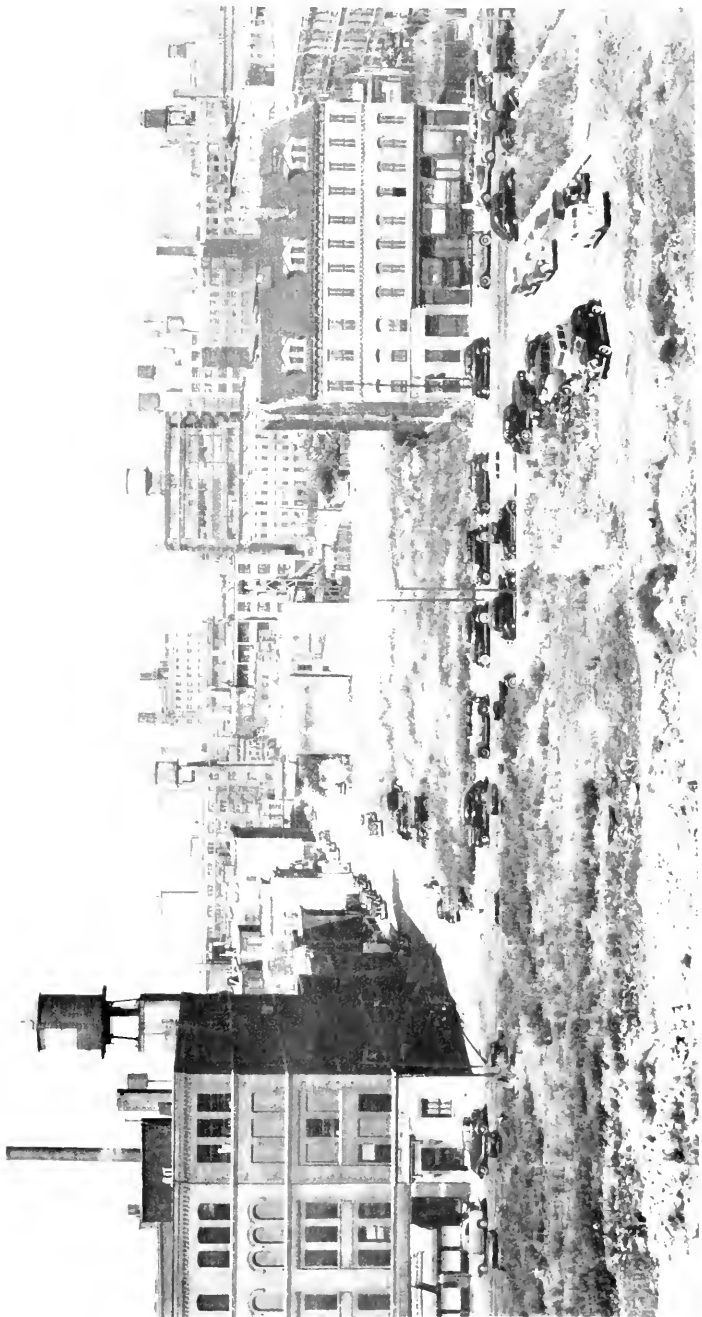
FROM 1937 REPORT TO
 COMMITTEE ON LOCAL TRANSPORTATION

FIGURE 6



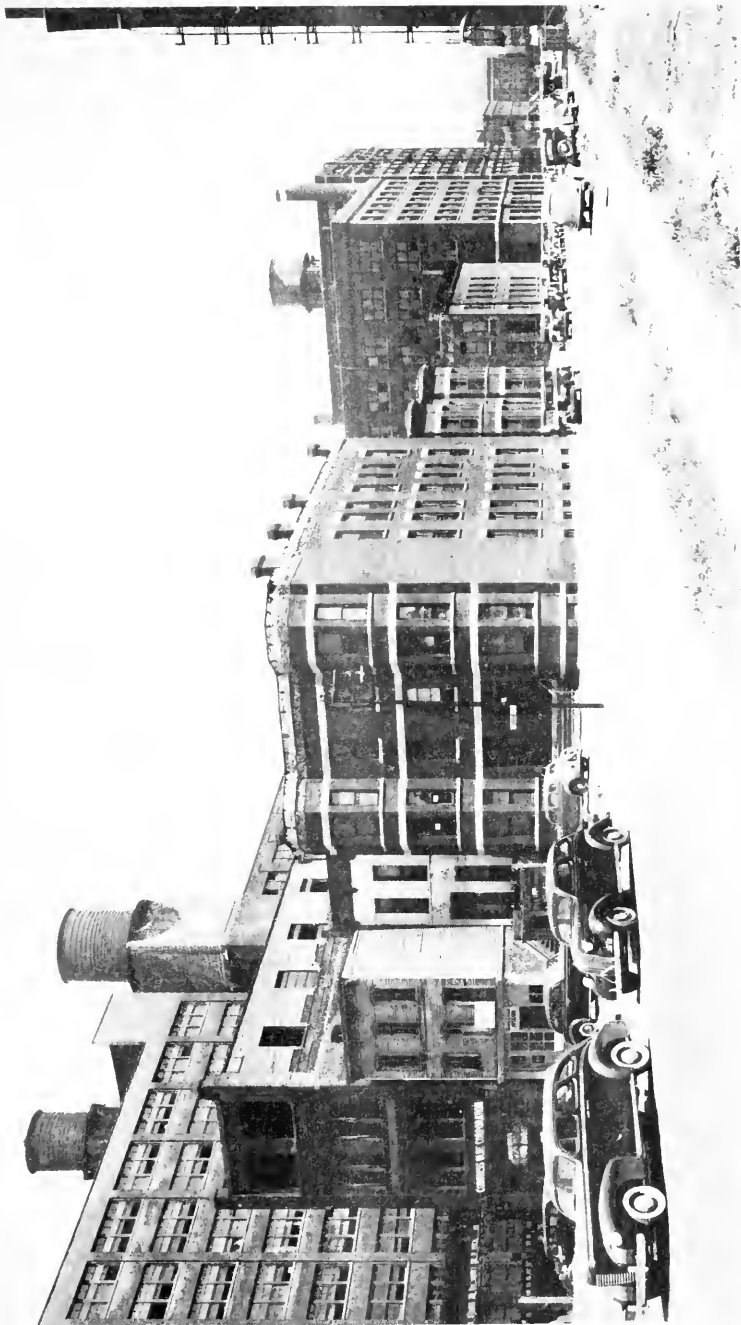


· CONGRESS · STREET · IMPROVEMENT · 1939
· PROPOSED · PLAZA · EAST · OF · THE · CHICAGO · RIVER ·



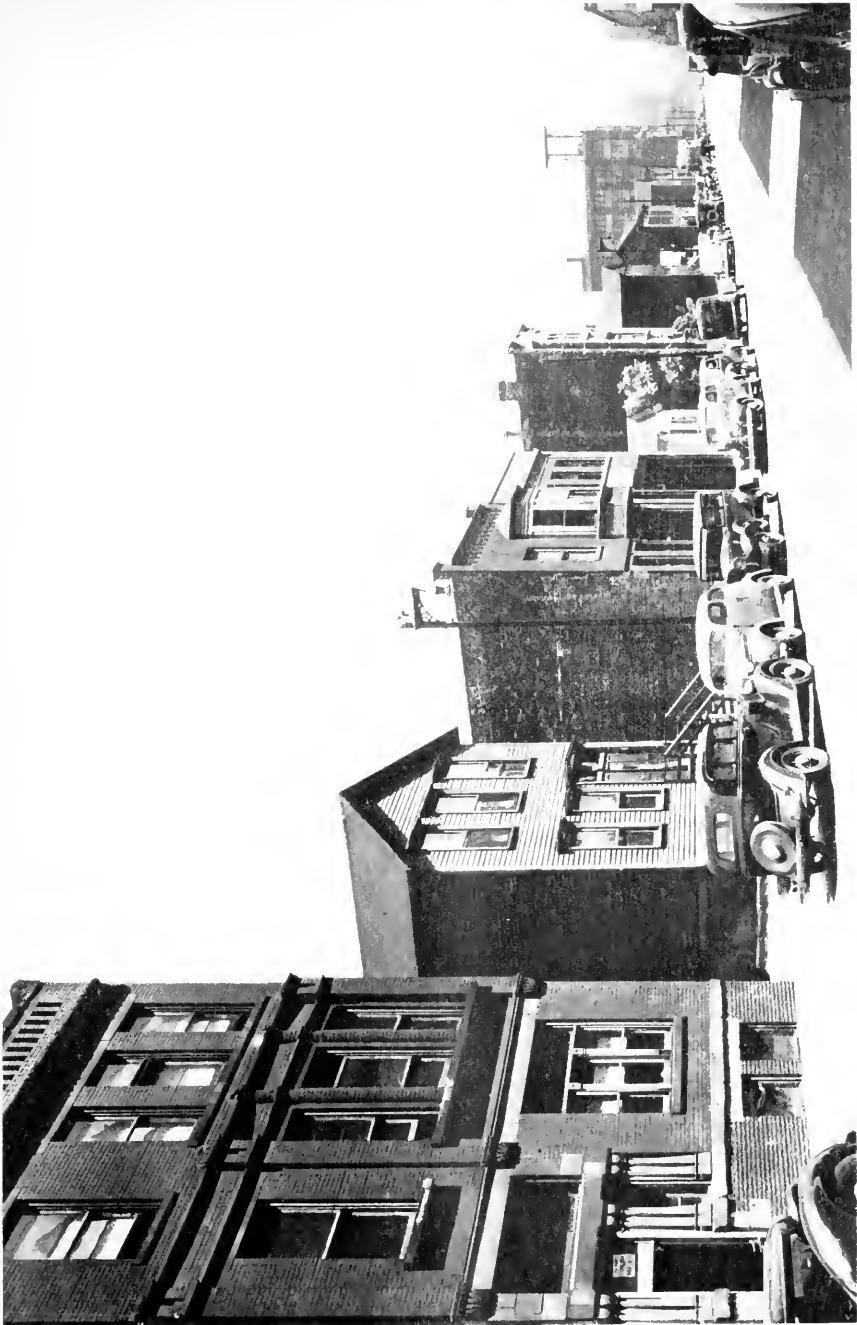
VIEW LOOKING WEST ON CONGRESS STREET
FROM JEFFERSON STREET

FIGURE 8



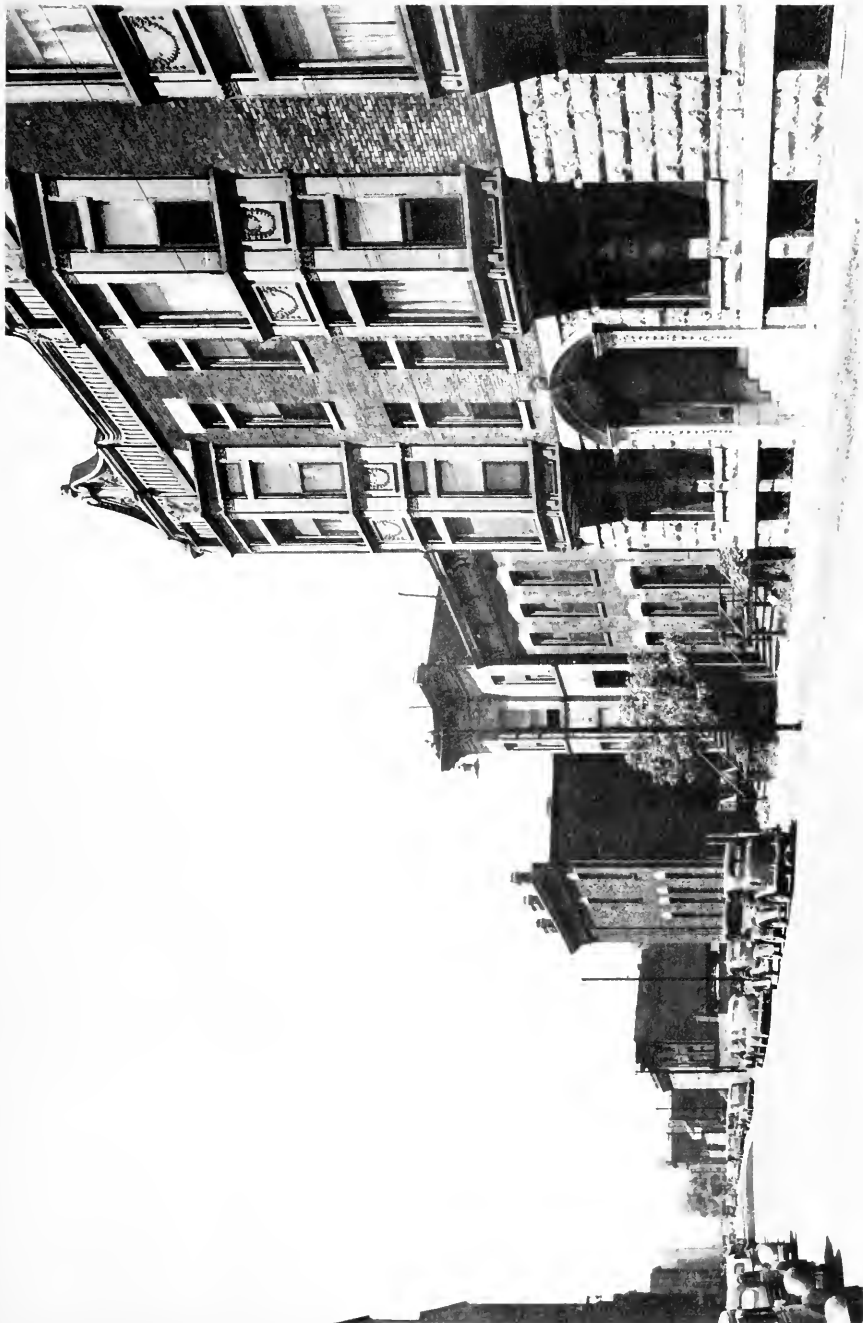
VIEW LOOKING EAST ON CONGRESS STREET
NEAR SANGAMON STREET

FIGURE 9

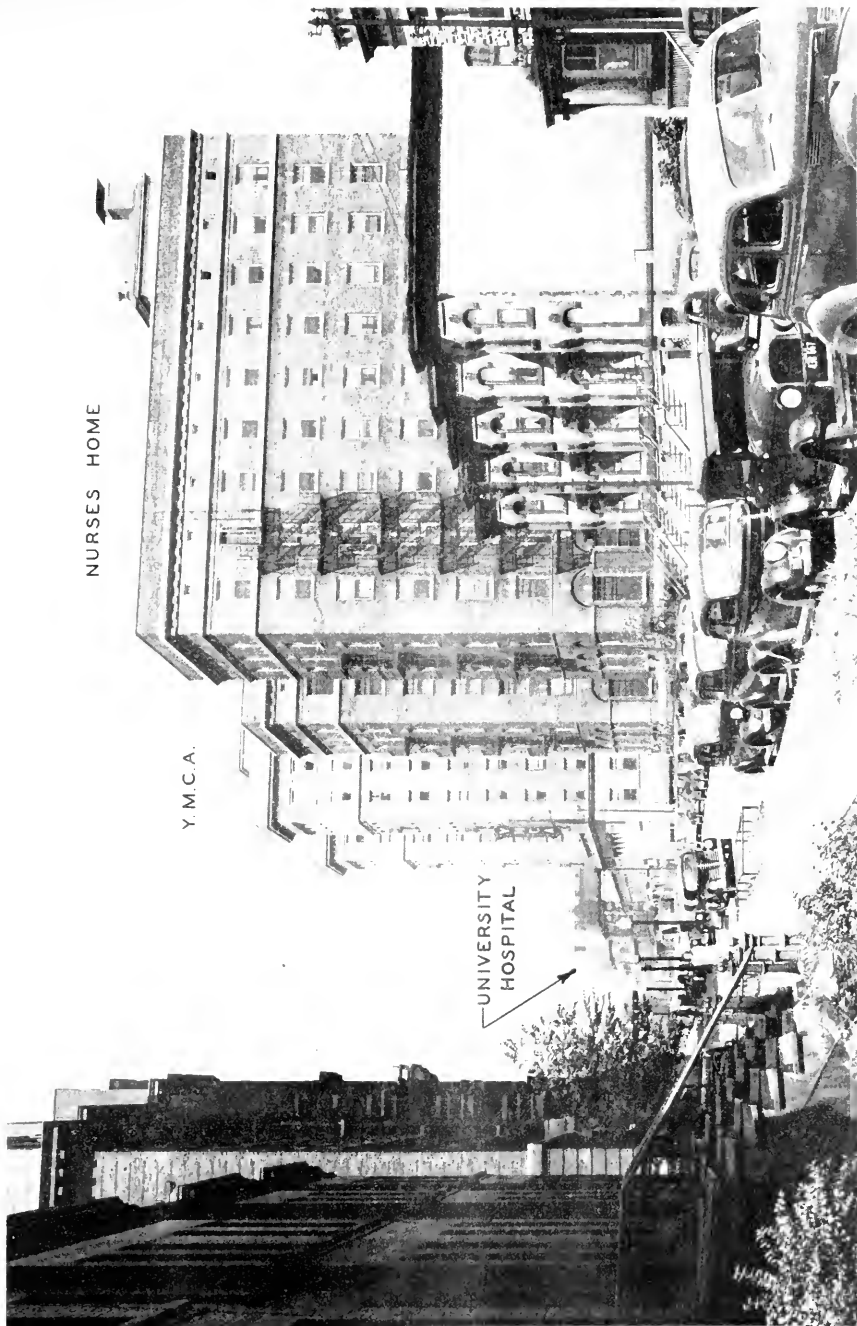


VIEW LOOKING EAST ON CONGRESS STREET
NEAR RACINE AVENUE

FIGURE 10



VIEW LOOKING WEST ON CONGRESS STREET
NEAR RACINE AVENUE



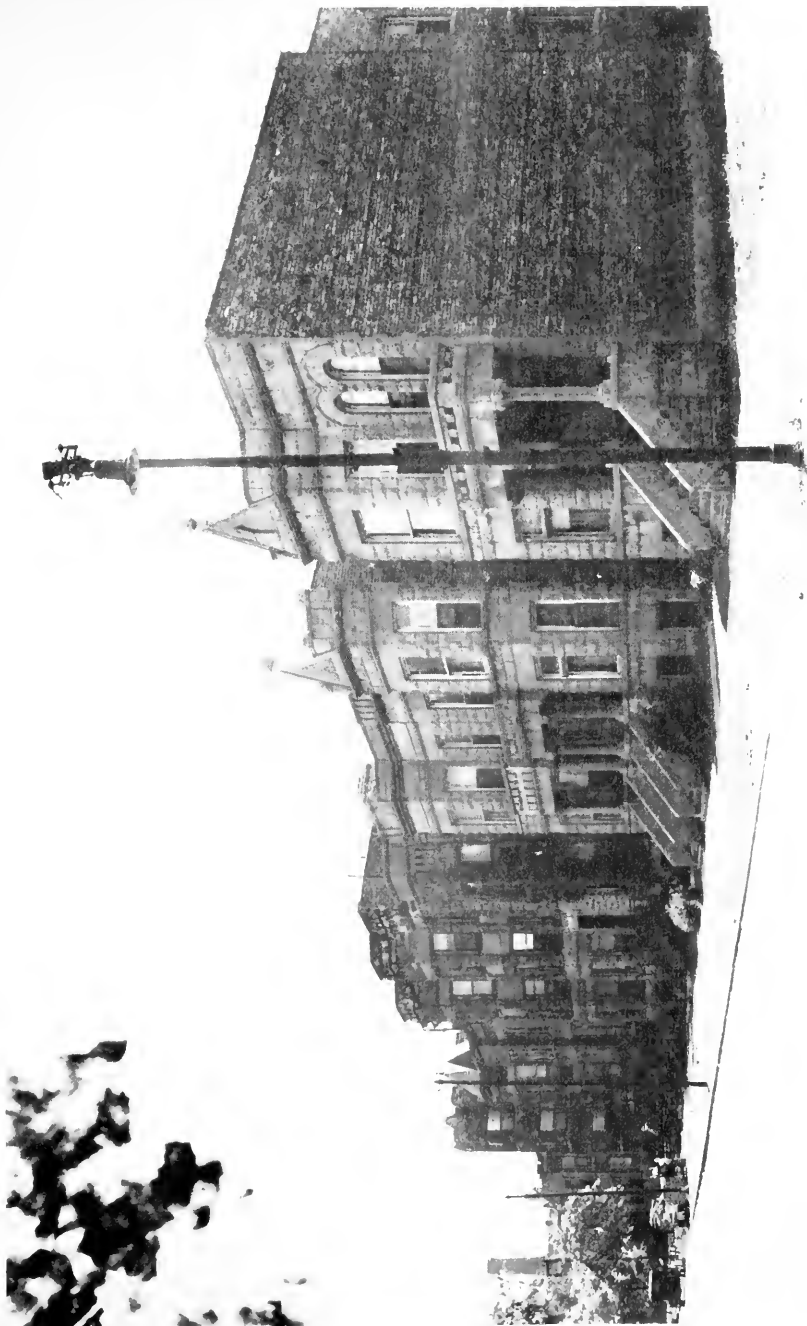
NURSES HOME

Y.M.C.A.

UNIVERSITY
HOSPITAL

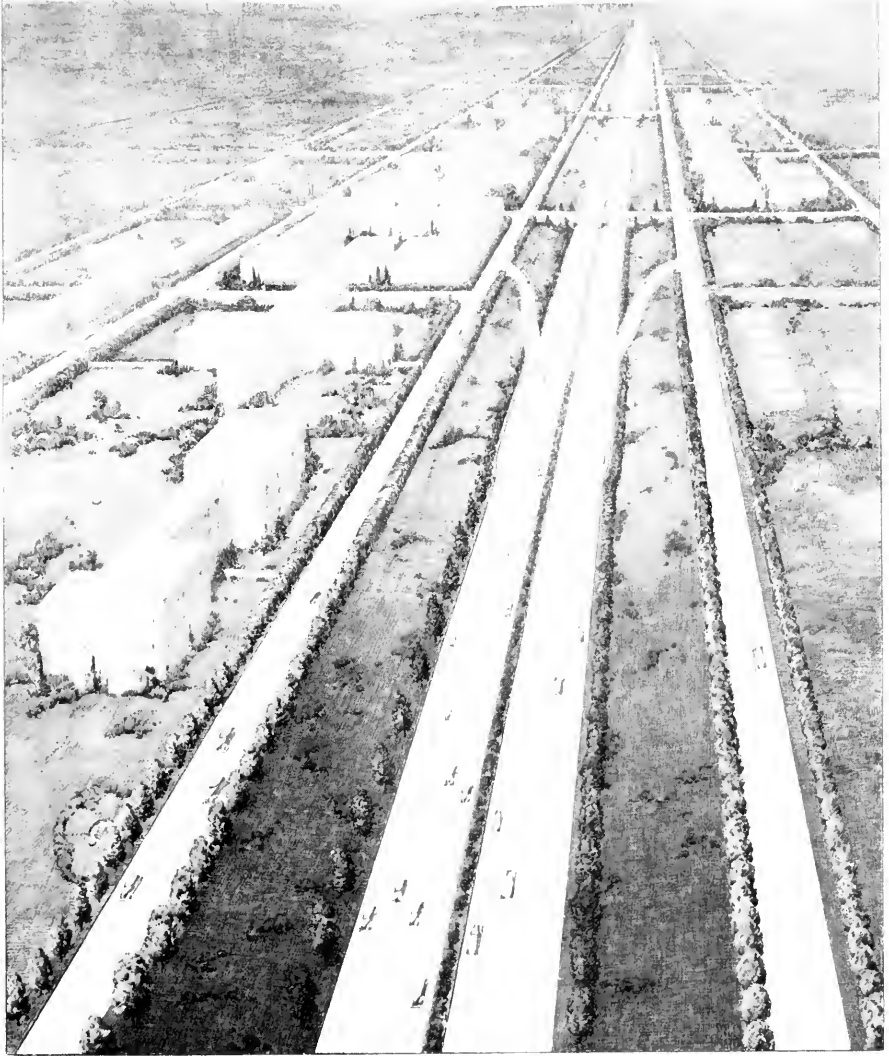
VIEW LOOKING WEST ON CONGRESS STREET
NEAR PAULINA STREET

FIGURE 12



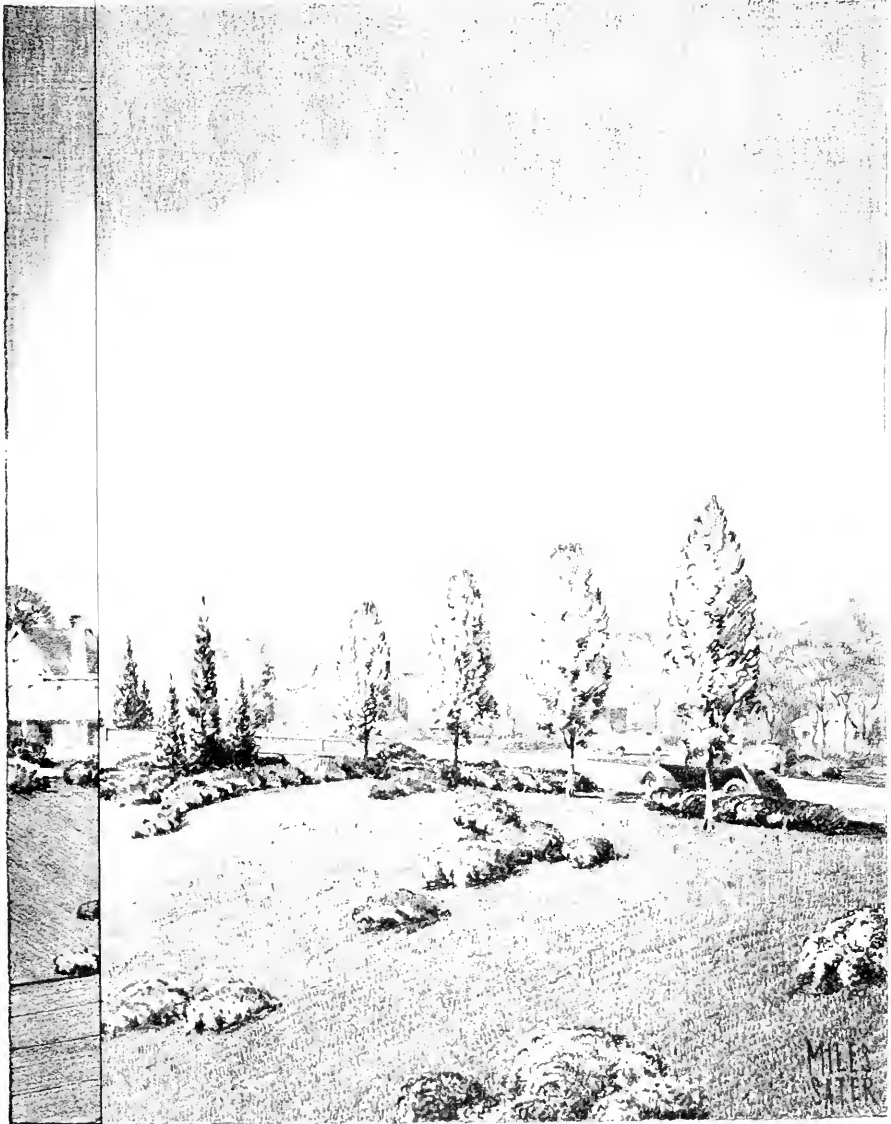
VIEW LOOKING EAST ON VAN BUREN STREET
NEAR CENTRAL PARK AVENUE

FIGURE 13

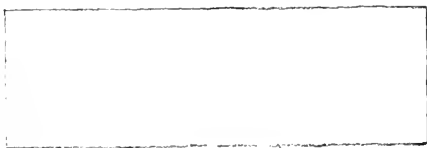


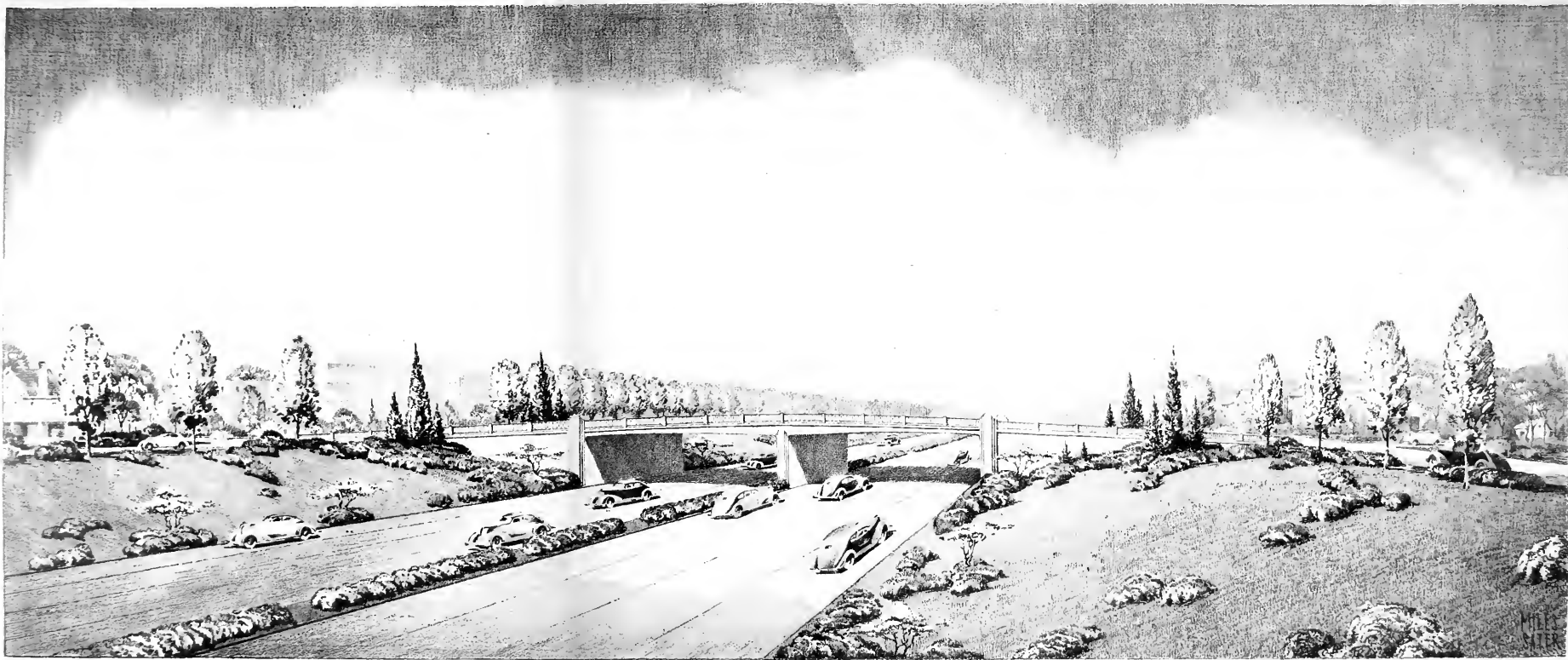
CITY OF CHICAGO
DEPARTMENT OF SUBWAYS AND TRACTION
A SUGGESTED DEVELOPMENT OF A WEST SIDE SUPERHIGHWAY
IMPROVEMENT BETWEEN GARFIELD PARK AND COLUMBUS PARK
PERSPECTIVE OF

FIGURE 14



D · TRACTION ·
SUPERHIGHWAY ·
STRUCTURE ·





CITY OF CHICAGO · · · DEPARTMENT OF SUBWAYS AND TRACTION ·
· A SUGGESTION FOR THE DEVELOPMENT OF A WEST SIDE SUPERHIGHWAY ·
· PERSPECTIVE NEAR TYPICAL OVERPASS STRUCTURE ·



VIEW LOOKING WEST BETWEEN GLADYS AVENUE AND VAN BUREN STREET
FROM LAVERGNE AVENUE

FIGURE 16

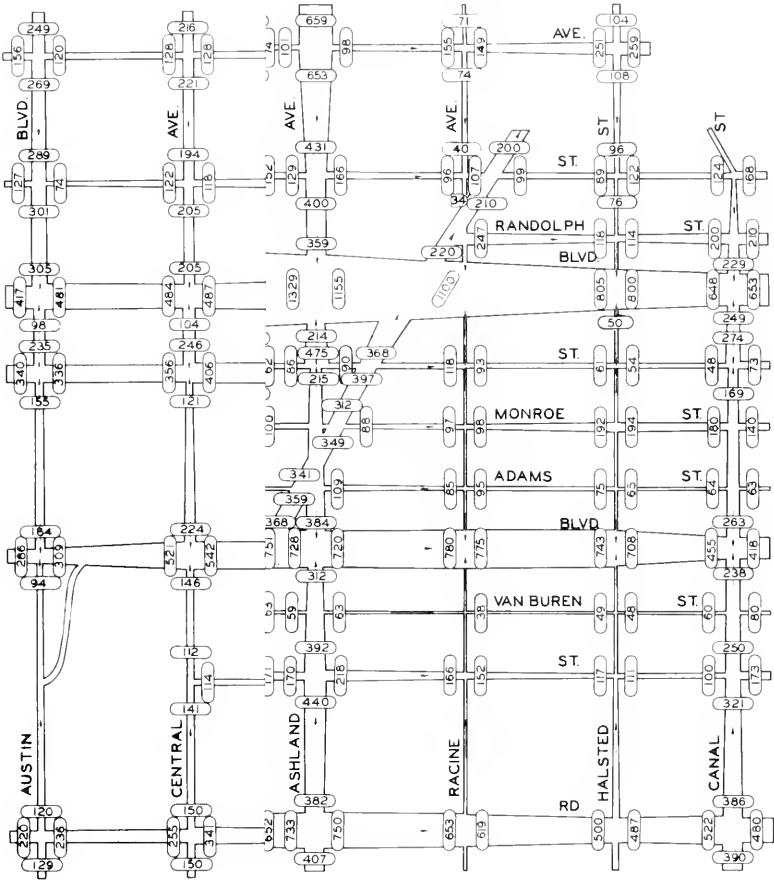
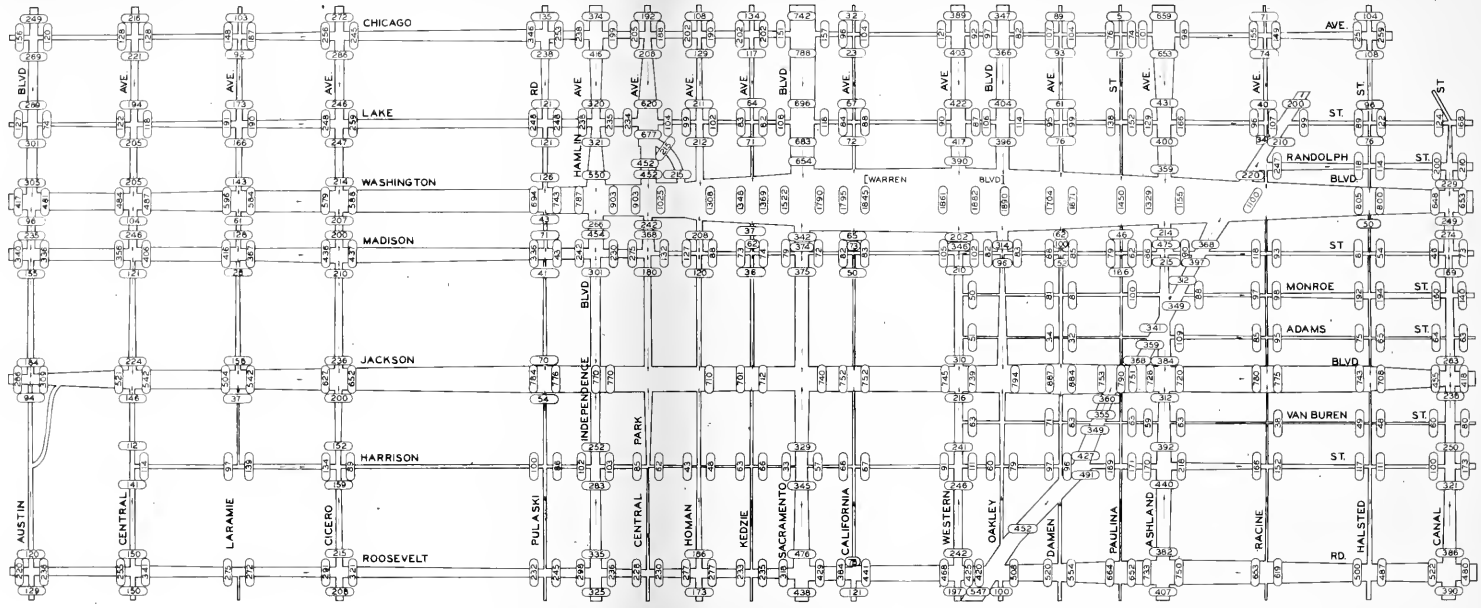
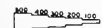


CHART
 SENGER VEHICLE TRAFFIC
 RTY MINUTE PERIOD
 TS BY VARIOUS AGENCIES 1938-1939

VOLUME OF



SCALE
VEHICLES PER MAXIMUM
THIRTY MINUTE PERIOD



VOLUME OF TRAFFIC INDICATED: 1/100

FLOW CHART
OF EXISTING INBOUND PASSENGER VEHICLE TRAFFIC
DURING MAXIMUM THIRTY MINUTE PERIOD
BASED ON TYPICAL WEEKDAY COUNTS BY VARIOUS AGENCIES 1938-1939

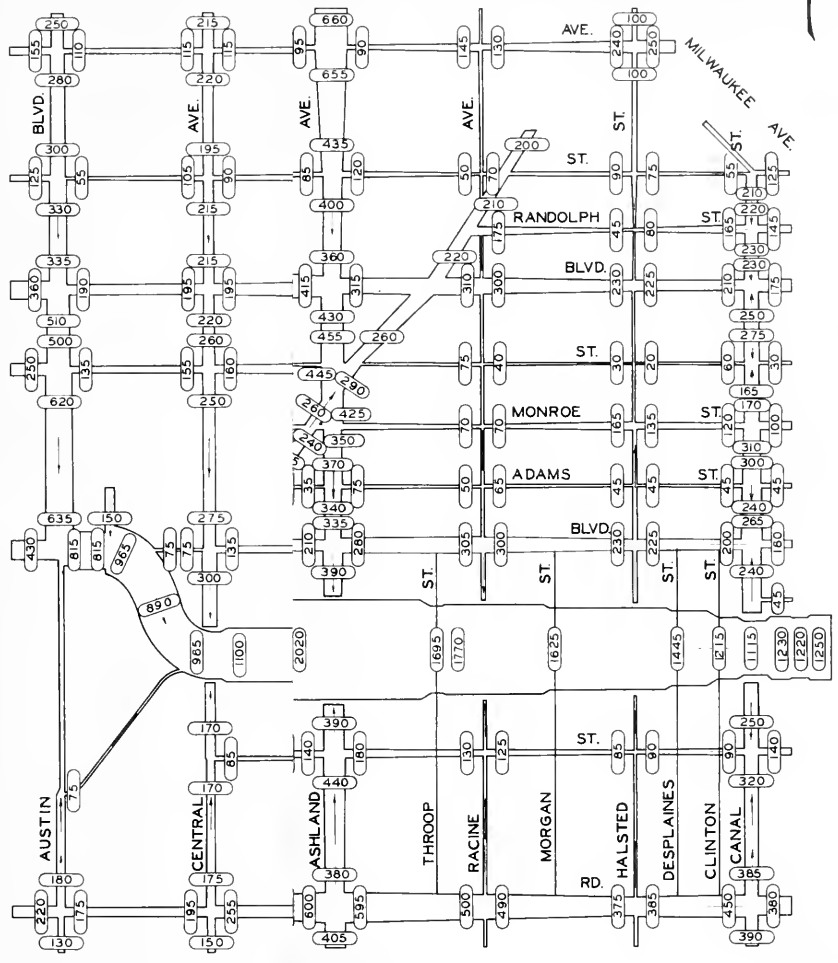
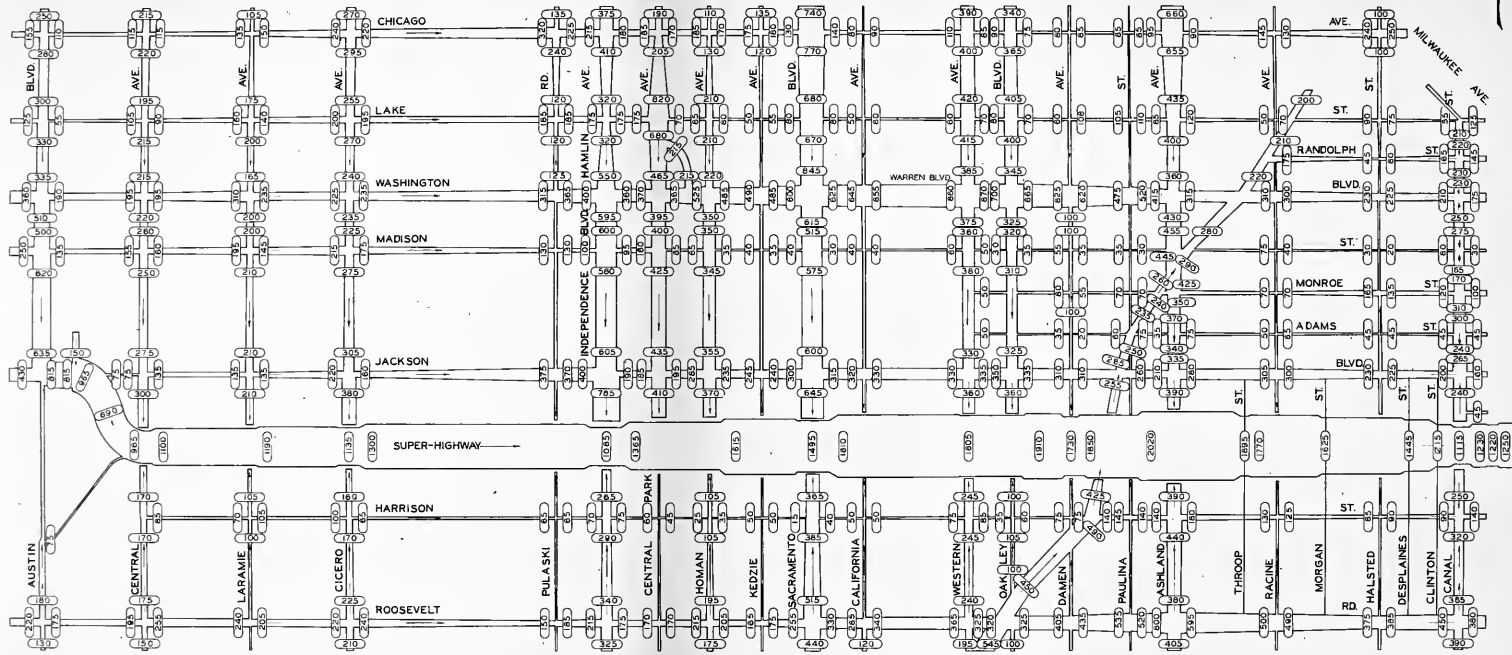


CHART
 OF EXISTING INBOUND TRAFFIC
 BUSINESS DISTRICT
 AND PROPOSED WEST SIDE SUPERHIGHWAY
 THIRTY MINUTE PERIOD
 TRAFFIC VOLUMES BY VARIOUS AGENCIES 1938-1939

VOLUME OF TRAFFIC



SCALE
 VEHICLES PER MAXIMUM
 THIRTY MINUTE PERIOD

100 200 300 400 500

VOLUME OF TRAFFIC INDICATED THUS 100

FLOW CHART
 INDICATING REDISTRIBUTION OF EXISTING INBOUND TRAFFIC
 TO CENTRAL BUSINESS DISTRICT
 OVER EXISTING THOROUGHFARES AND PROPOSED WEST SIDE SUPERHIGHWAY
 DURING MAXIMUM THIRTY MINUTE PERIOD
 BASED ON TYPICAL WEEKDAY COUNTS BY VARIOUS AGENCIES 1938-1939

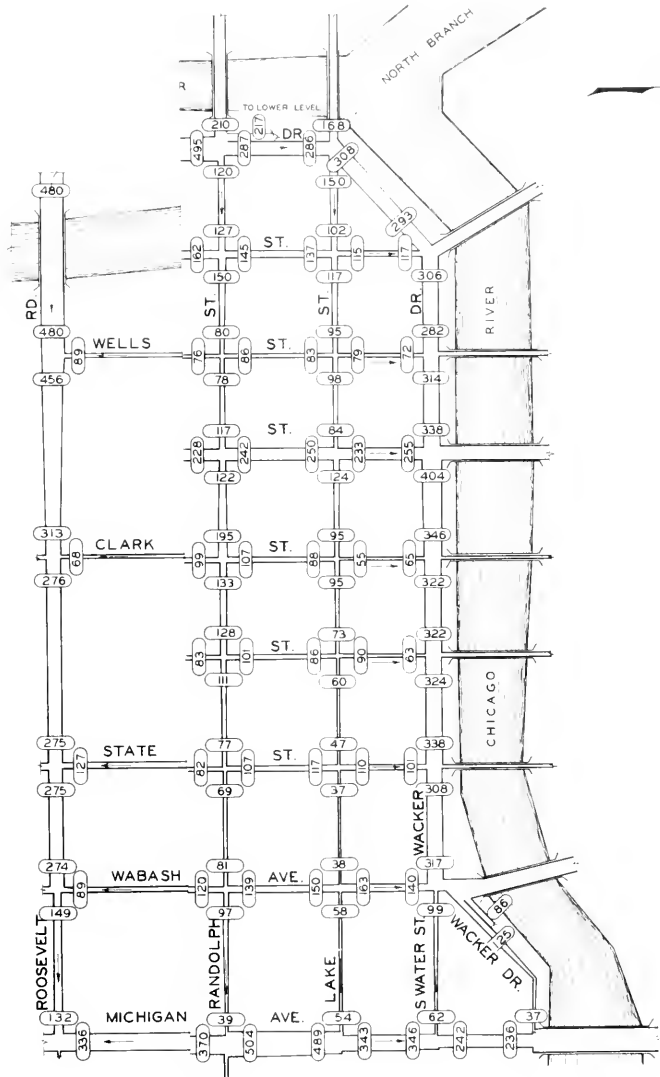
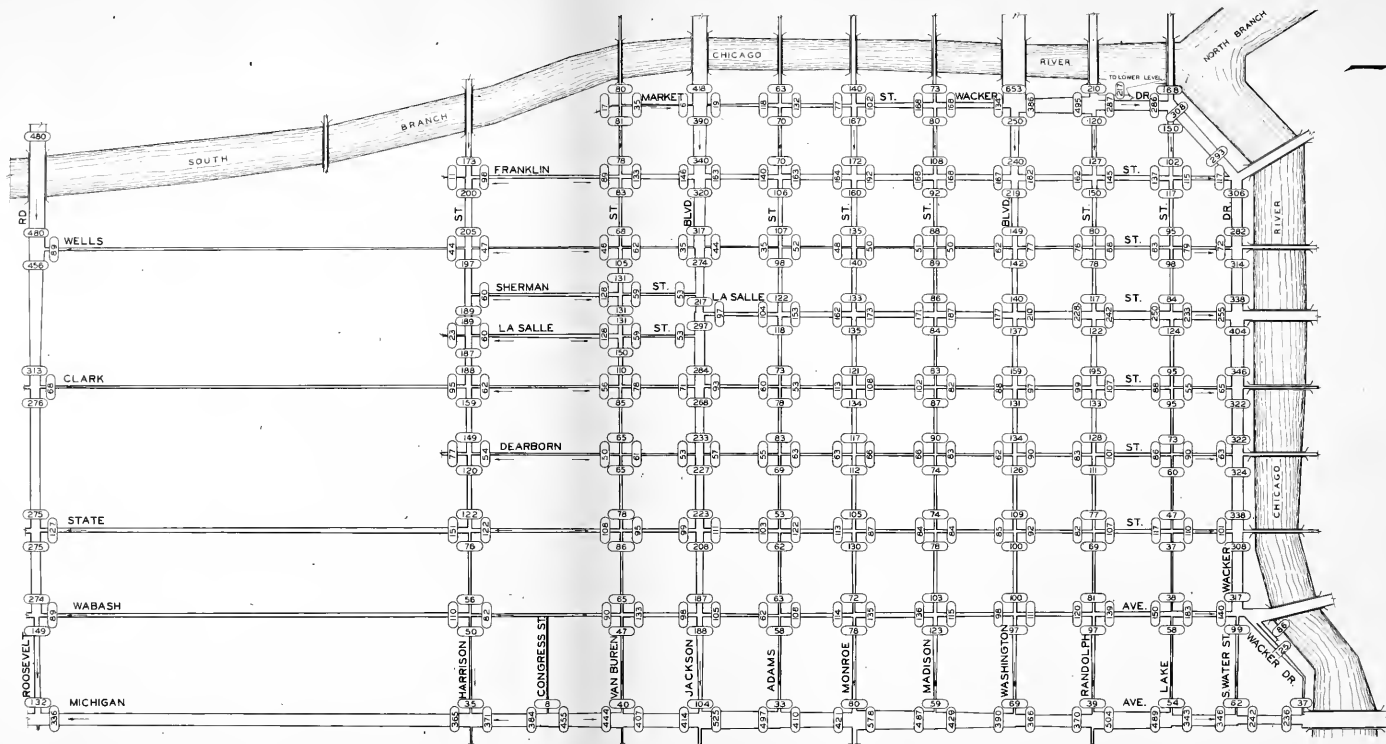


CHART
 PASSENGER VEHICLE TRAFFIC
 QUANTITY PER FIFTEEN MINUTE PERIOD
 BY VARIOUS AGENCIES 1938-1939

VOLUME OF



FLOW CHART
 OF EXISTING INBOUND PASSENGER VEHICLE TRAFFIC
 DURING MAXIMUM THIRTY MINUTE PERIOD
 BASED ON TYPICAL WEEKDAY COUNTS BY VARIOUS AGENCIES 1938-1939

SCALE
 VEHICLES PER MAXIMUM
 THIRTY MINUTE PERIOD
 0 200 400 600 800 1000
 VOLUME OF TRAFFIC INDICATED THUS 1000

MARKET

FRANKLIN

WELLS

SHERMAN

LA SALLE

CLARK

DEARBORN

STATE

WABASH

MICHIGAN

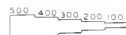


LEGEND

- EXISTING SOUTH BOUND PASSENGER VEHICLES
- EXISTING SOUTH BOUND SERVICE VEHICLES
- EXISTING NORTH BOUND SERVICE VEHICLES
- EXISTING NORTH BOUND PASSENGER VEHICLES
- INCREASE IN NORTH BOUND PASSENGER VEHICLES

SCALE

VEHICLES PER MAXIMUM THIRTY MINUTE PERIOD



LOW

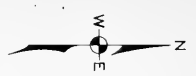
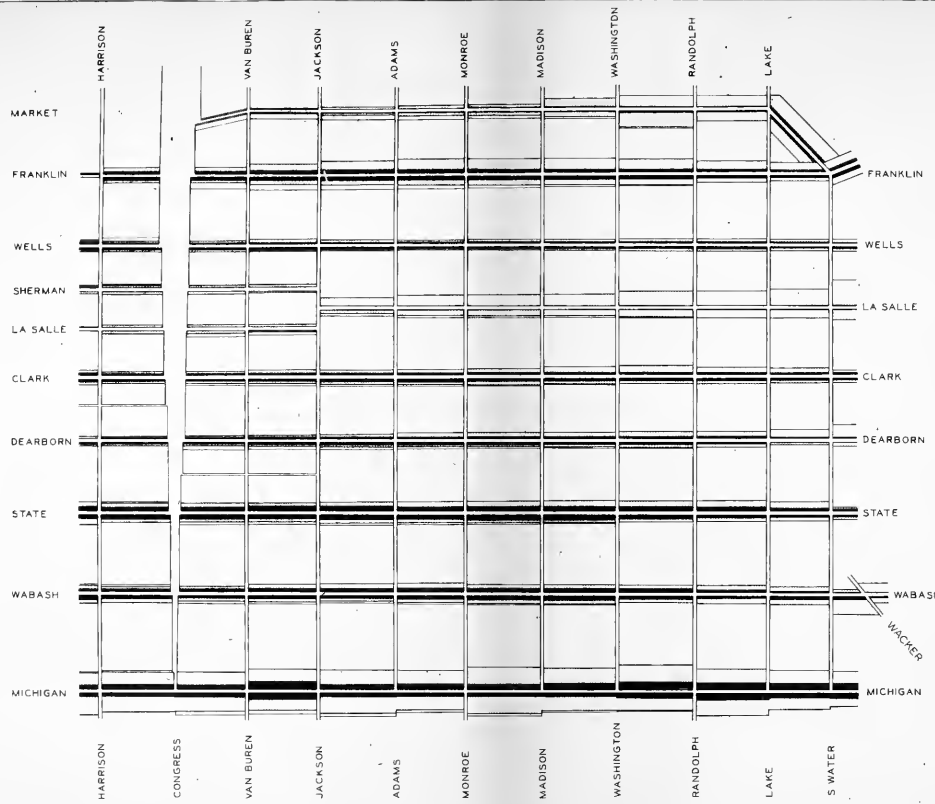
CENTRAL BUSINESS DISTRICT

PASSENGER VEHICLE TRAFFIC

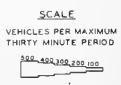
AT SUPERHIGHWAY

THIRTY MINUTE PERIOD

BY VARIOUS AGENCIES 1938-1939



- LEGEND
- EXISTING SOUTH BOUND PASSENGER VEHICLES
 - EXISTING SOUTH BOUND SERVICE VEHICLES
 - EXISTING NORTH BOUND SERVICE VEHICLES
 - EXISTING NORTH BOUND PASSENGER VEHICLES
 - INCREASE IN NORTH BOUND PASSENGER VEHICLES

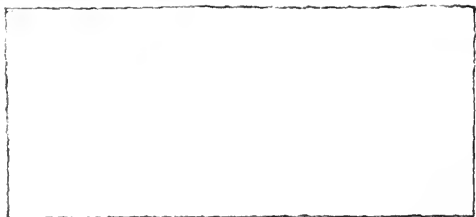


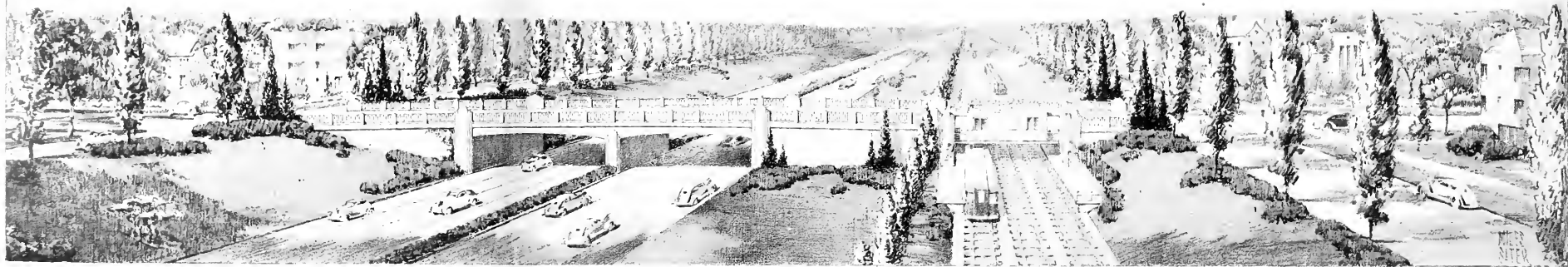
TRAFFIC FLOW
 ON NORTH AND SOUTH STREETS IN CENTRAL BUSINESS DISTRICT
 SHOWING INCREASE IN INBOUND PASSENGER VEHICLE TRAFFIC
 FROM CONGRESS STREET SUPERHIGHWAY
 DURING MAXIMUM THIRTY MINUTE PERIOD
 BASED ON TYPICAL WEEKDAY COUNTS BY VARIOUS AGENCIES 1938-1939



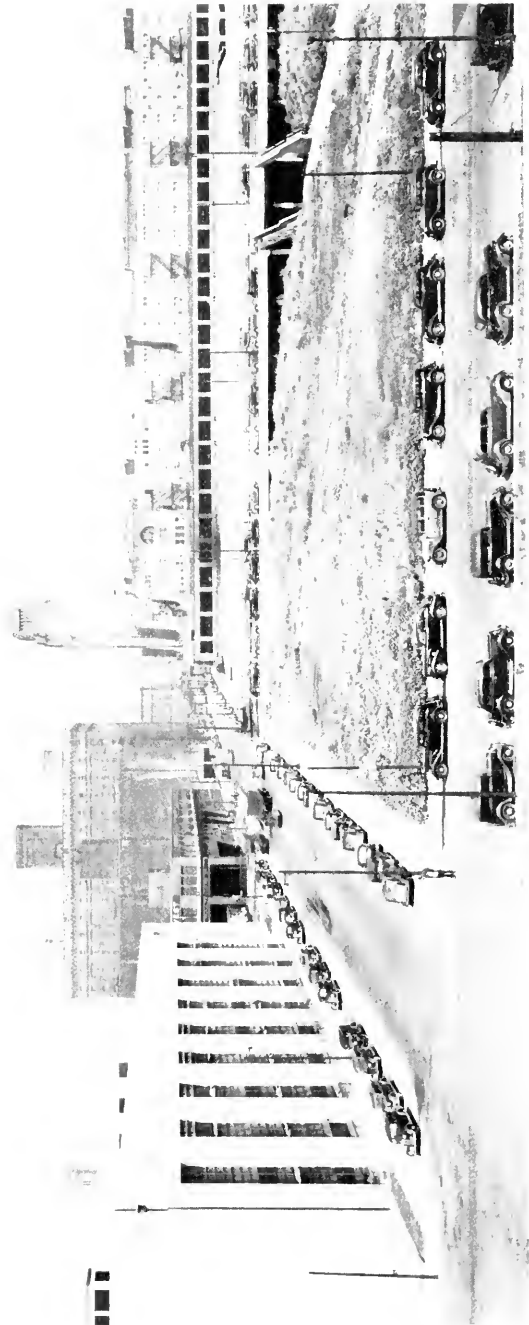
AND · TRACTION ·
E · SUPERHIGHWAY ·

TATION ·





· CITY · OF · CHICAGO · · · DEPARTMENT · OF · SUBWAYS · AND · TRACTION ·
· A · SUGGESTION · FOR · THE · DEVELOPMENT · OF · A · WEST · SIDE · SUPERHIGHWAY ·
· ALTERNATE · PLAN ·
· PERSPECTIVE · NEAR · RAPID · TRANSIT · STATION ·



VIEW LOOKING EAST ON POLK STREET
FROM JEFFERSON STREET

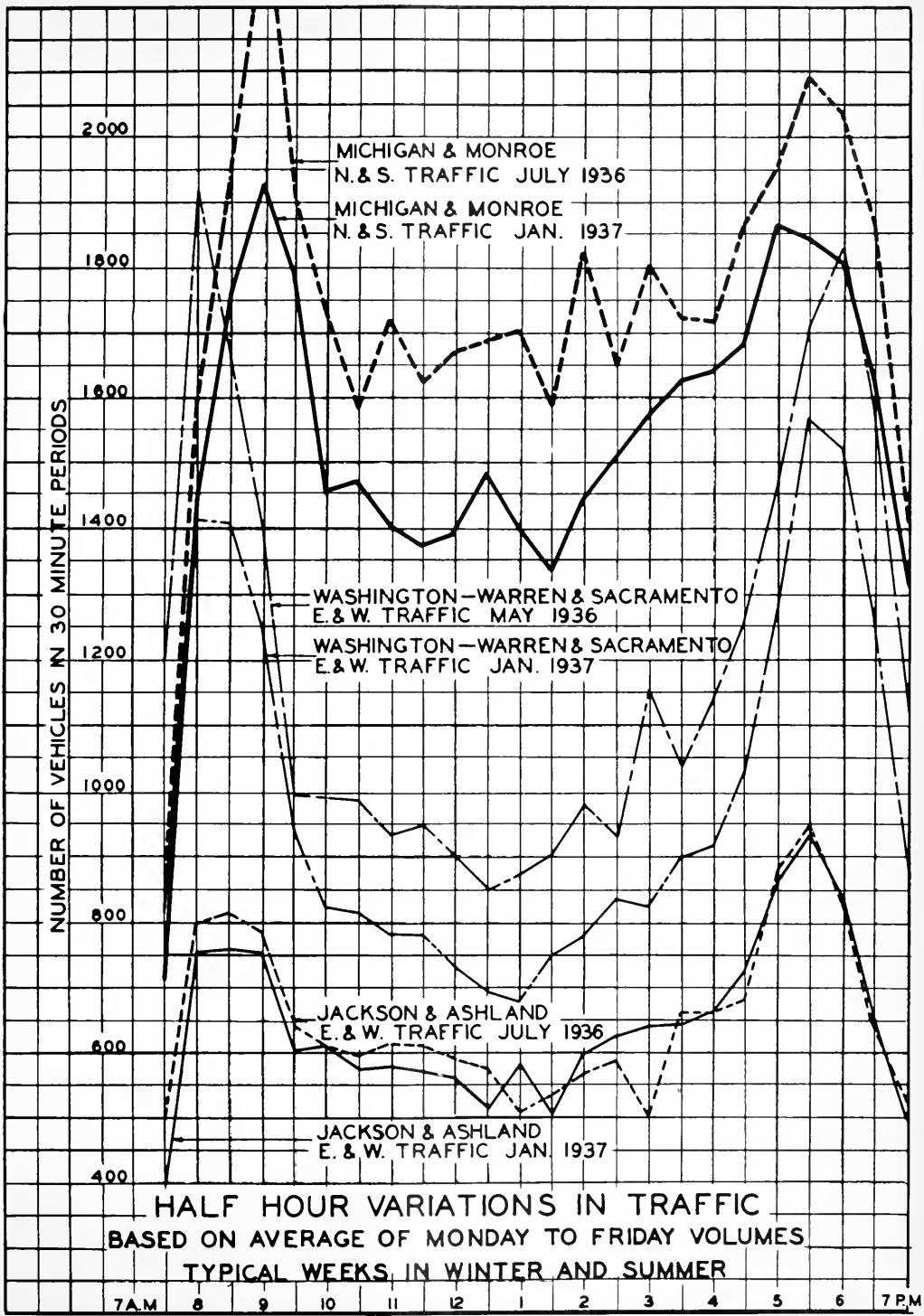


FIGURE 23

DAILY VARIATIONS IN TOTAL 24 HOUR TRAFFIC BASED ON AVERAGE OF WEEKDAY COUNTS DURING MONTHS OF JANUARY AND JULY

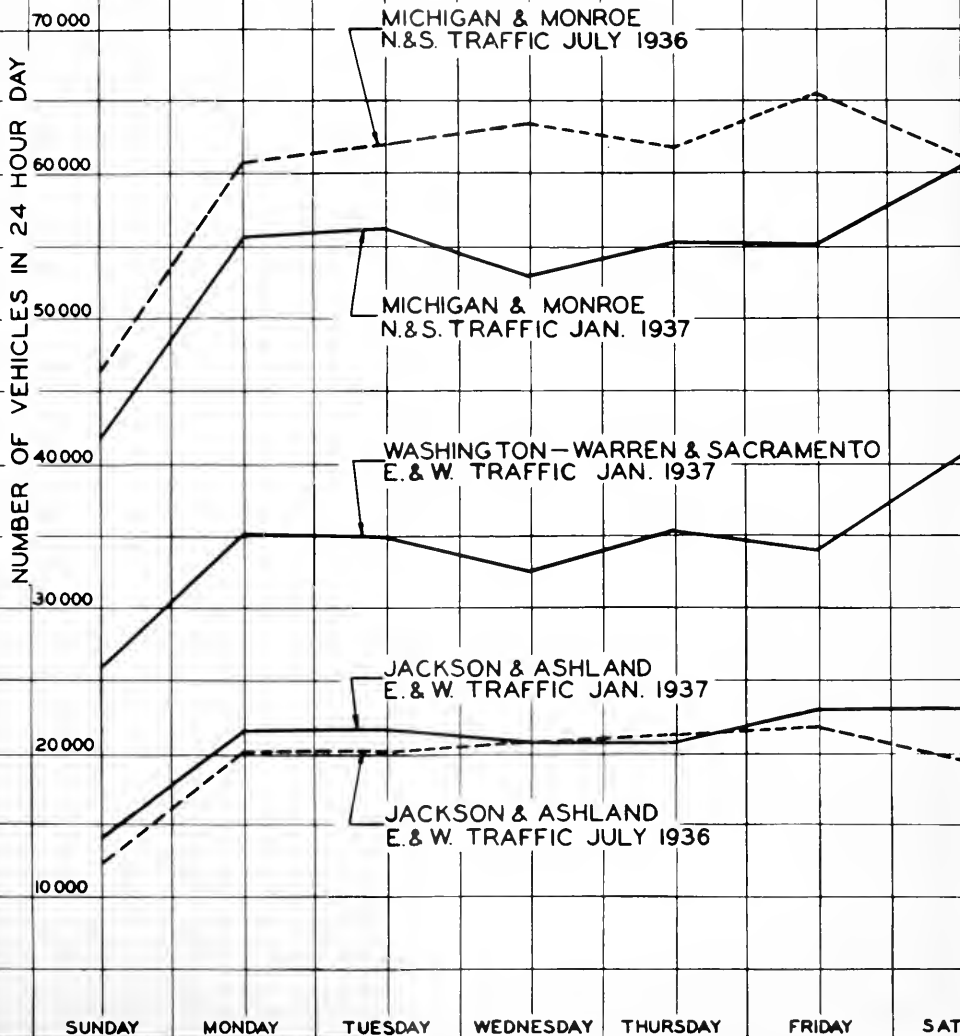


FIGURE 24

MONTHLY VARIATIONS IN TOTAL 24-HOUR TYPICAL WEEK DAY TRAFFIC

INTERSECTION	DIRECTION OF TRAFFIC	AVERAGE	MAX.	MIN.	% OF AVERAGE MAX.	MIN.
MICHIGAN & MONROE	N. & S.	58 330	65 823	54 771	113	94
WASHINGTON— WARREN & SACRAMENTO	E. & W.	38 120	41 830	35 003	110	92
JACKSON & ASHLAND	E. & W.	22 270	24 745	20 759	111	93

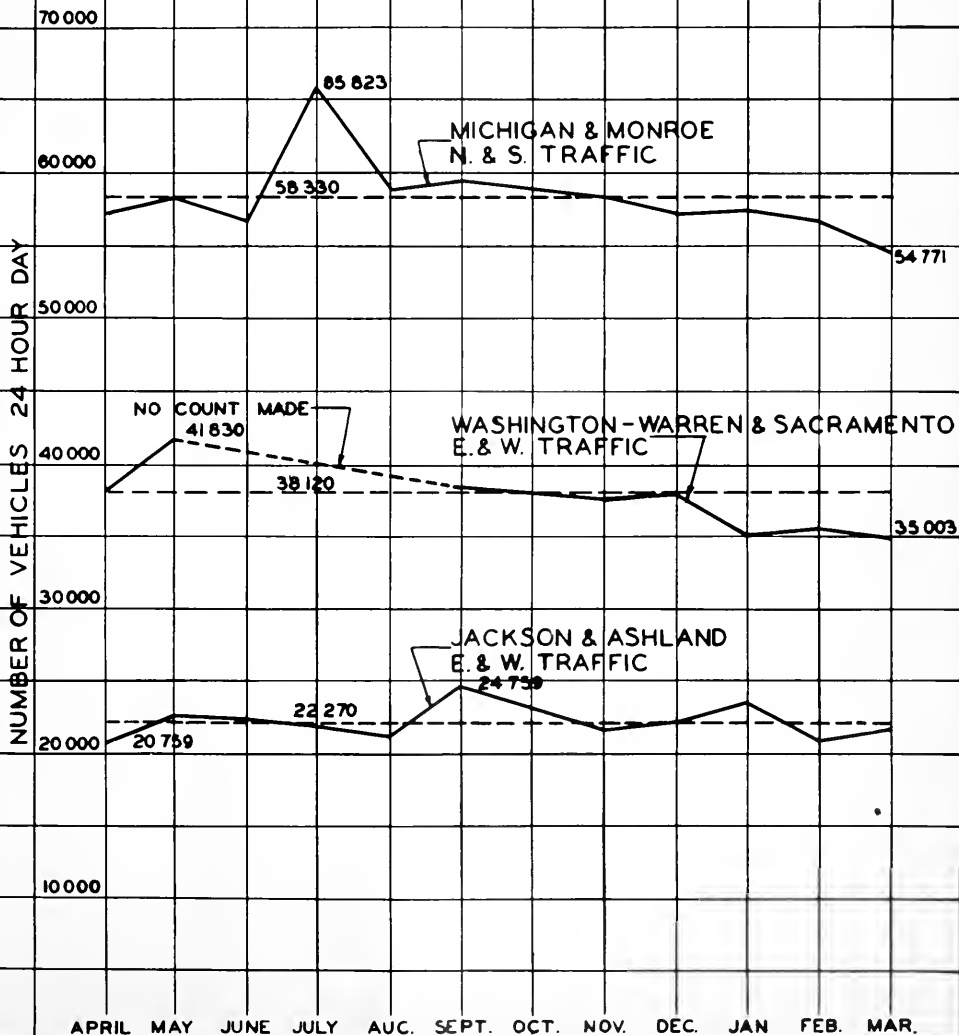


FIGURE 25

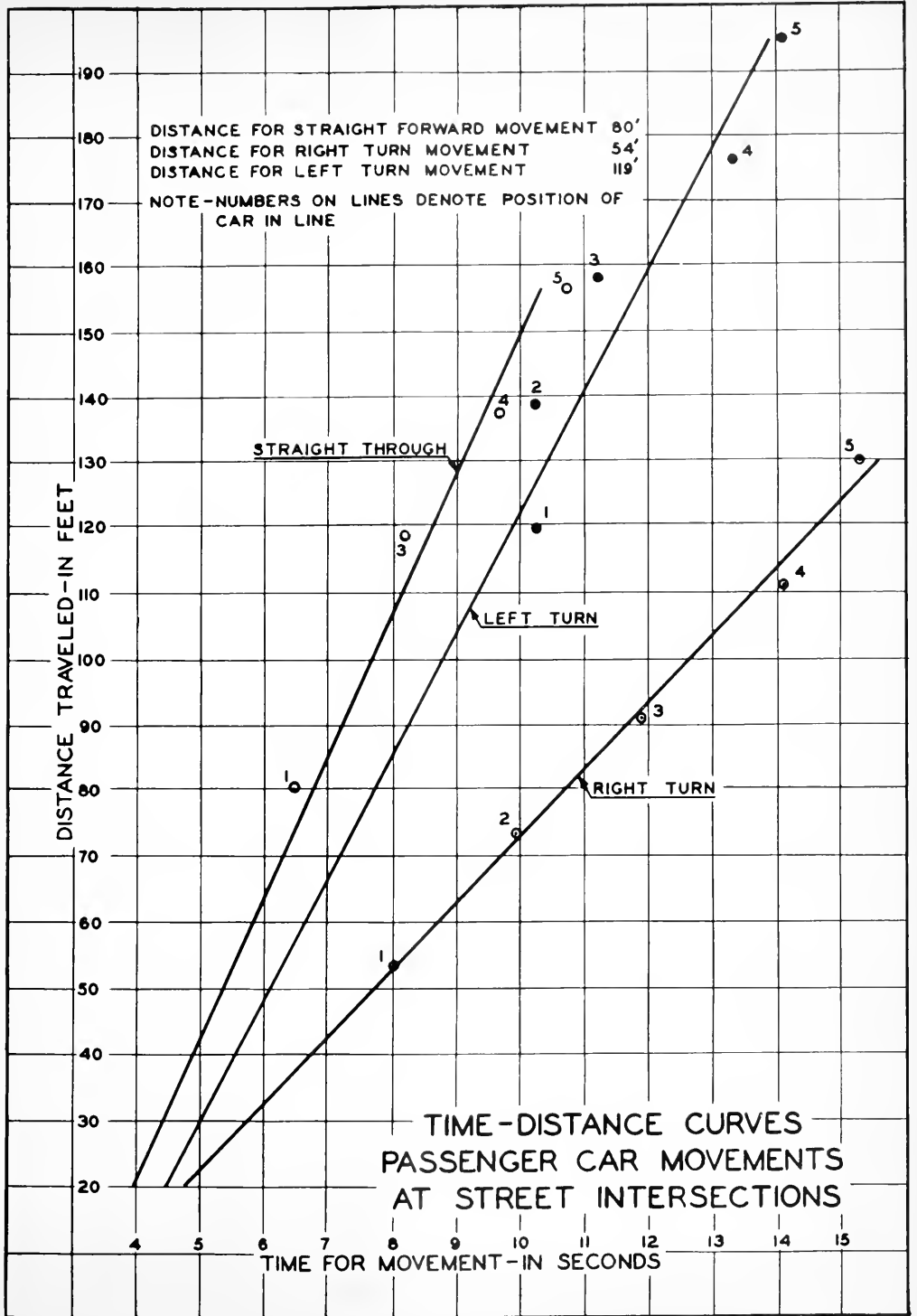
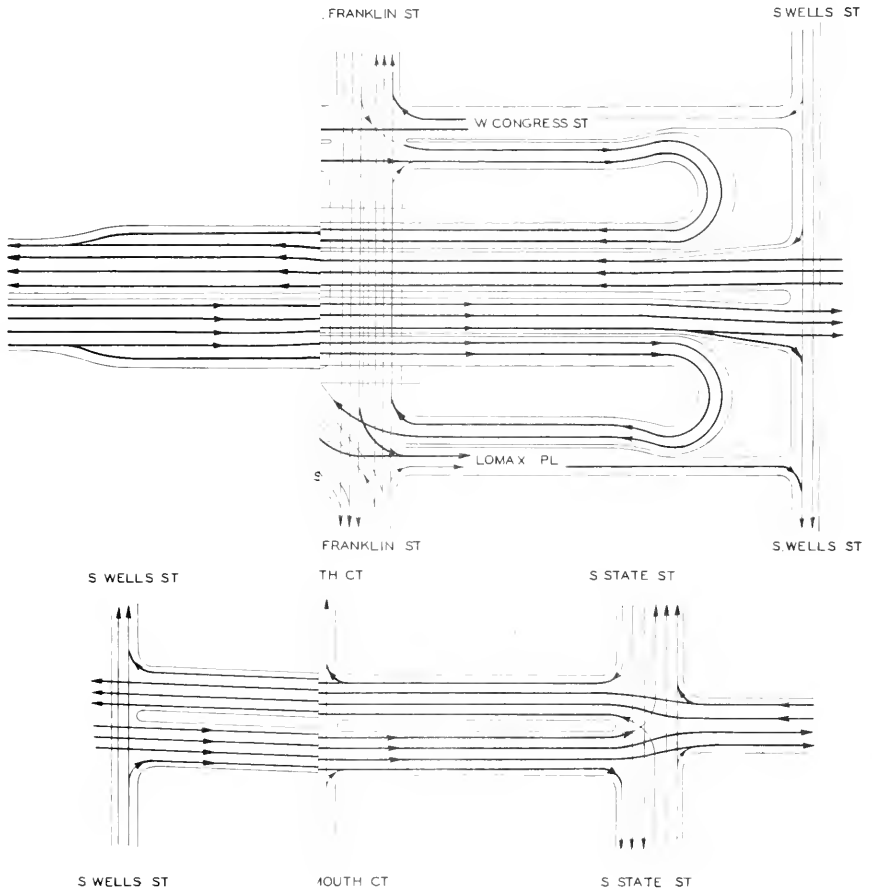
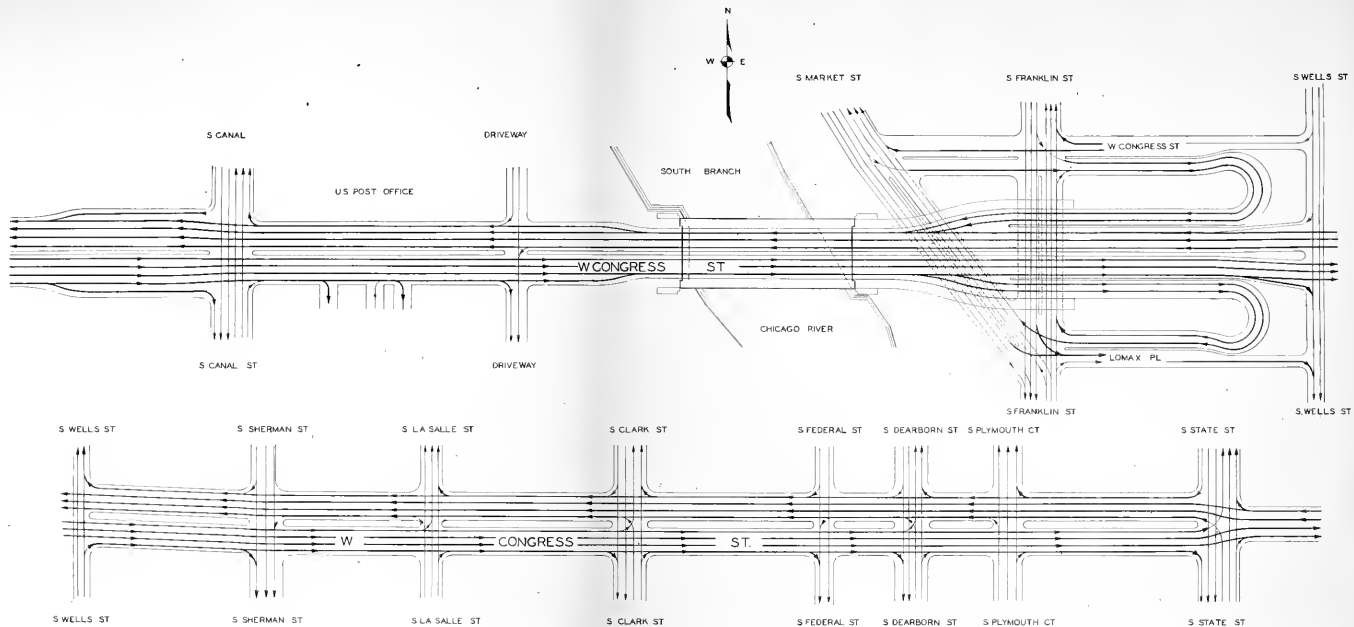


FIGURE 26



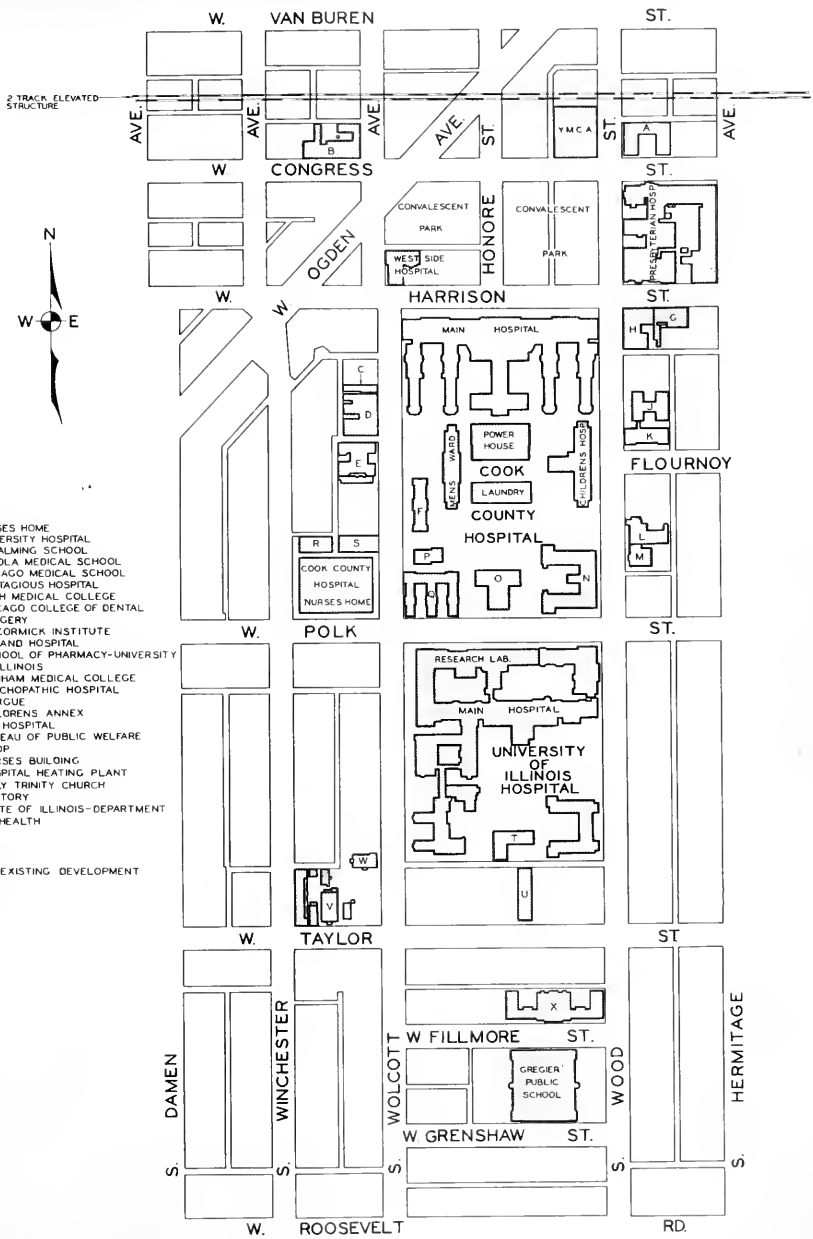
CITY OF CHICAGO
 DEPARTMENT OF SUBWAYS AND TRACTION
 WIDENING AND IMPROVEMENT
 OF CONGRESS STREET
 CHART SHOWING SUGGESTED TRAFFIC CONTROL
 CANAL STREET TO STATE STREET



LEGEND

- TRAFFIC MOVEMENTS - EAST AND WEST SIGNAL
- ↑ TRAFFIC MOVEMENTS - NORTH AND SOUTH SIGNAL

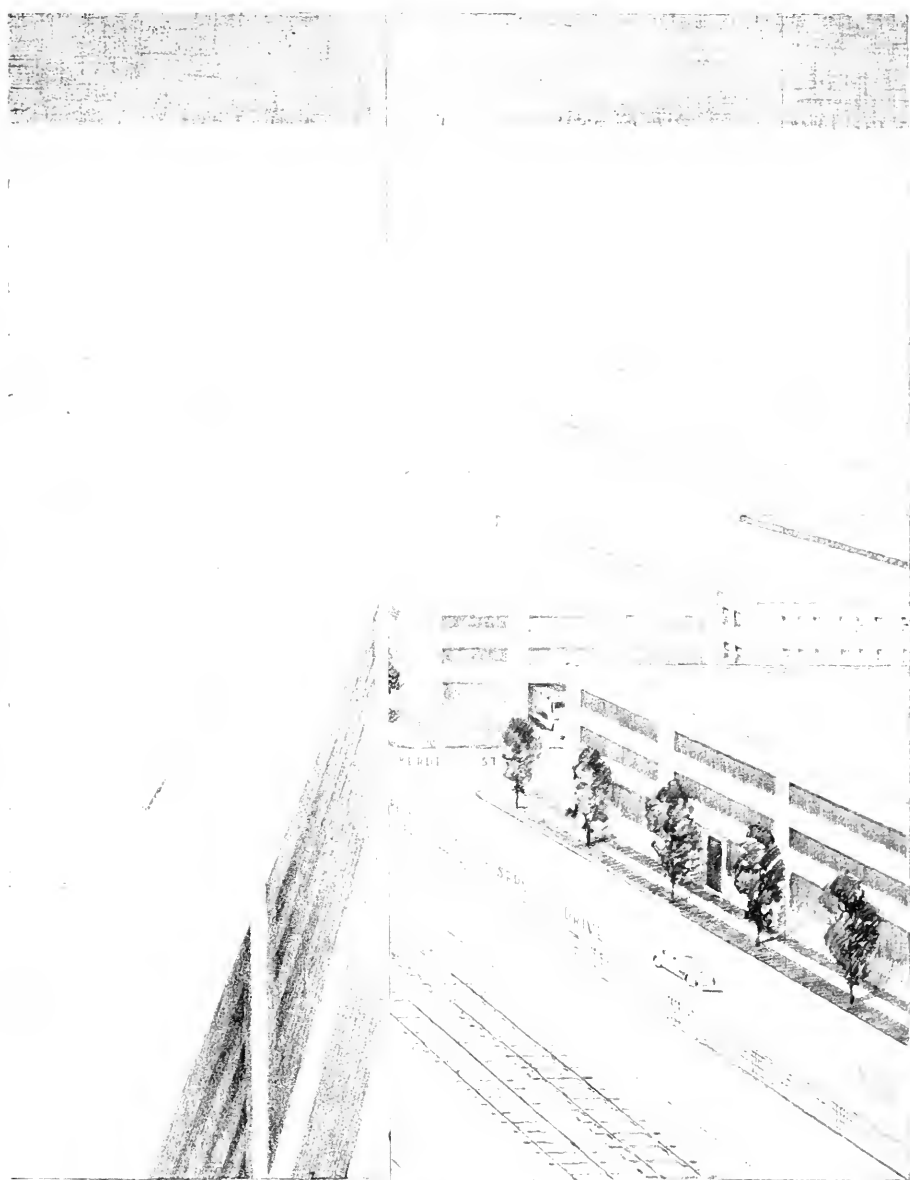
CITY OF CHICAGO
 DEPARTMENT OF SUBWAYS AND TRACTION
 WIDENING AND IMPROVEMENT
 OF CONGRESS STREET
 CHART SHOWING SUGGESTED TRAFFIC CONTROL
 CANAL STREET TO STATE STREET



- A- NURSES HOME
- B- UNIVERSITY HOSPITAL
- C- EMBALMING SCHOOL
- D- LOYOLA MEDICAL SCHOOL
- E- CHICAGO MEDICAL SCHOOL
- F- CONTAGIOUS HOSPITAL
- G- RUSH MEDICAL COLLEGE
- H- CHICAGO COLLEGE OF DENTAL SURGERY
- J- MCCORMICK INSTITUTE
- K- DURAND HOSPITAL
- L- SCHOOL OF PHARMACY-UNIVERSITY OF ILLINOIS
- M- DUNHAM MEDICAL COLLEGE
- N- PSYCHOPATHIC HOSPITAL
- O- MORGUE
- P- CHILDRENS ANNEX
- Q- TB HOSPITAL
- R- BUREAU OF PUBLIC WELFARE
- S- SHOP
- T- NURSES BUILDING
- U- HOSPITAL HEATING PLANT
- V- HOLY TRINITY CHURCH
- W- RECTORY
- X- STATE OF ILLINOIS-DEPARTMENT OF HEALTH

EXISTING DEVELOPMENT

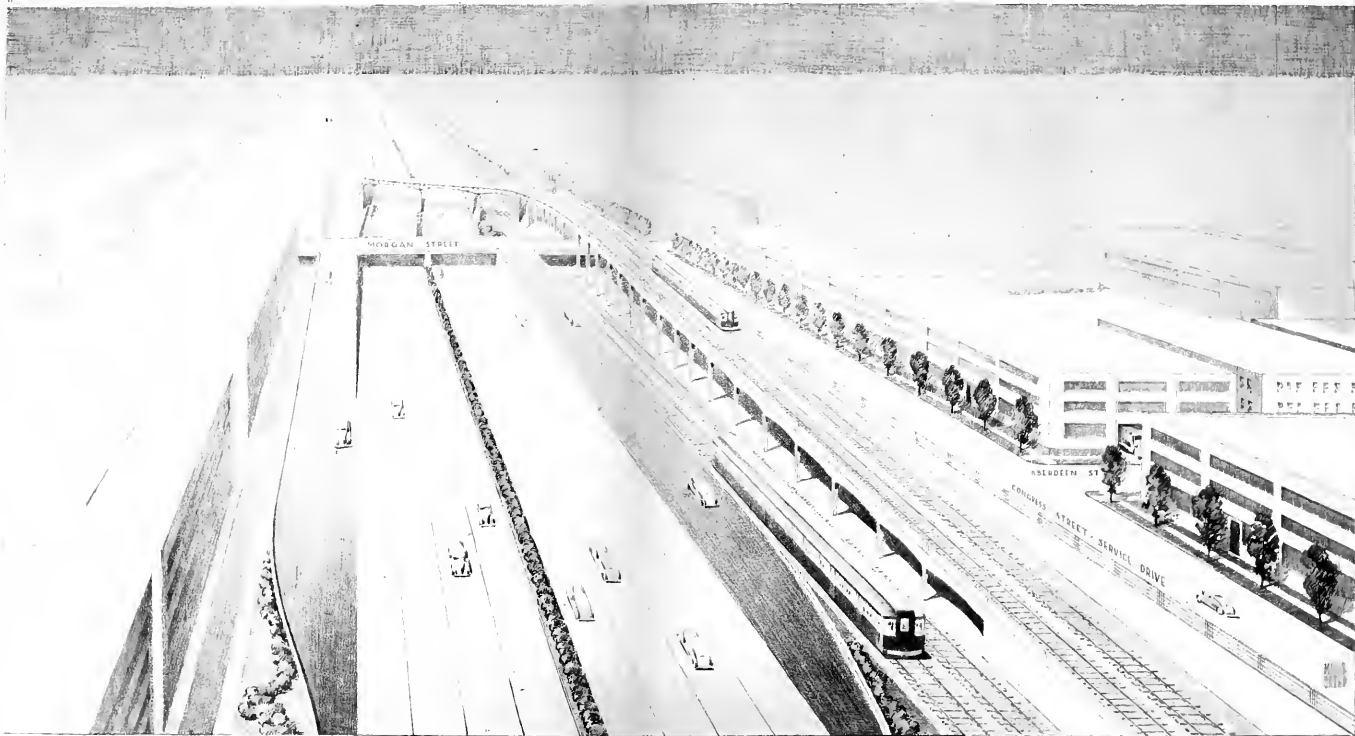
PLAT OF MEDICAL CENTER
SHOWING EXISTING DEVELOPMENT



· TION ·
· HIGHWAY ·

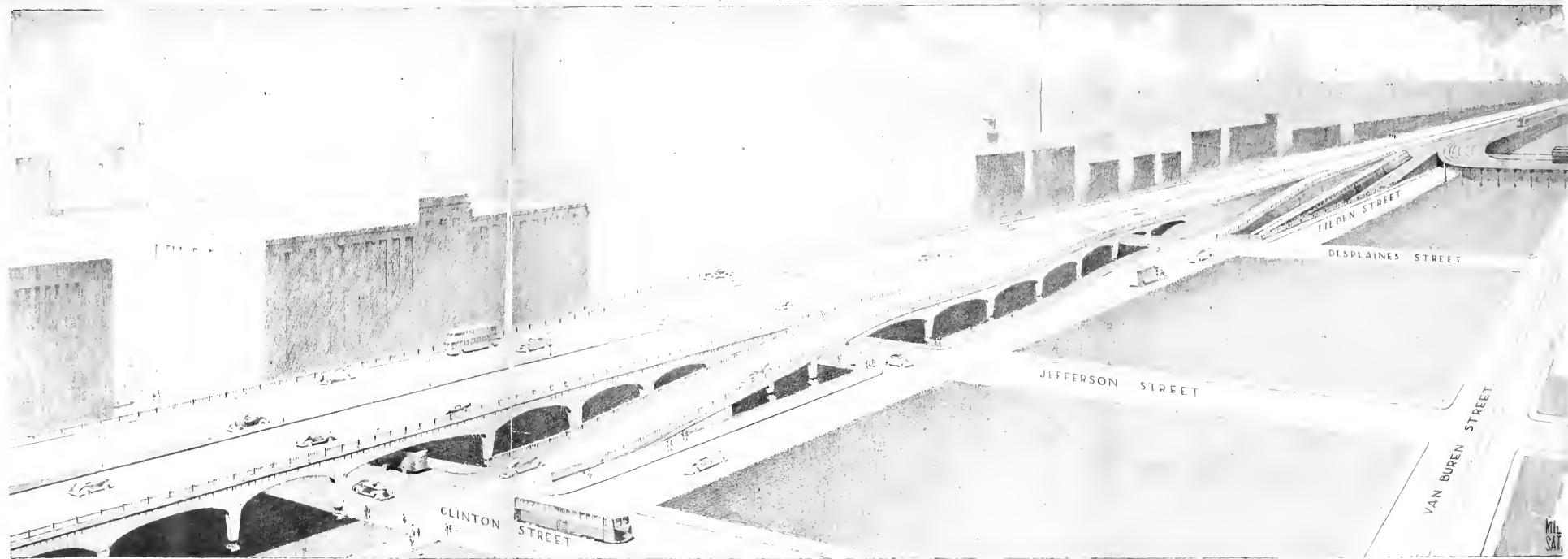


FIGURE 29



CITY OF CHICAGO · DEPARTMENT OF SUBWAYS AND TRACTION ·
A SUGGESTION FOR THE DEVELOPMENT OF A WEST SIDE SUPERHIGHWAY ·
· ALTERNATE PLAN ·
· PERSPECTIVE EAST OF RACINE AVENUE ·
· 1030 ·

FIGURE 29



CITY OF CHICAGO · DEPARTMENT OF SUBWAYS AND TRACTION ·
A SUGGESTION FOR THE DEVELOPMENT OF A WEST-SIDE SUPERHIGHWAY ·
PERSPECTIVE OF ·
ELEVATED SECTION · WEST OF CLINTON STREET ·
· 1939 ·

- 1 - TITLE SHEET TO SACRAMENTO BOULEVARD
- 2 - GENERAL PLAN - SUBWAY SYSTEM RK
- 3 - GENERAL PLAN IN THE CENTRAL CITY LIMITS
- 4 - PLAN AND PROFILE - CONGRESS STARK
- 5 - PLAN AND PROFILE - LAKE STREET PROFILE - HALSTED STREET TO CLINTON STREET
- 6 - PLAN AND PROFILE - WASHINGTON PROFILE - ABERDEEN STREET TO HALSTED STREET
- 7 - PLAN AND PROFILE - JACKSON S PROFILE - THROOP STREET TO ABERDEEN STREET
- 8 - TYPICAL SECTIONS - LOW LEVEL PROFILE - KEDZIE AVENUE TO THROOP STREET
- 9 - TYPICAL SECTIONS - HIGH LEVEL ROSS SECTIONS
- 10 - TYPICAL LOW LEVEL STATION DEN AVENUE TO ASHLAND BOULEVARD
- 11 - TYPICAL HIGH LEVEL STATION WIDZIE AVENUE TO SACRAMENTO BOULEVARD
- 12 - PLAN AND SECTION - CLINTON ELEVATED INCLINES
- 13 - GENERAL PLAN - CONGRESS STREET TO BE ACQUIRED
- 14 - A SUGGESTED PLAN - STATE STREET ALTERNATE ALIGNMENTS
- 15 - PLAN AND PROFILE - WELLS STR

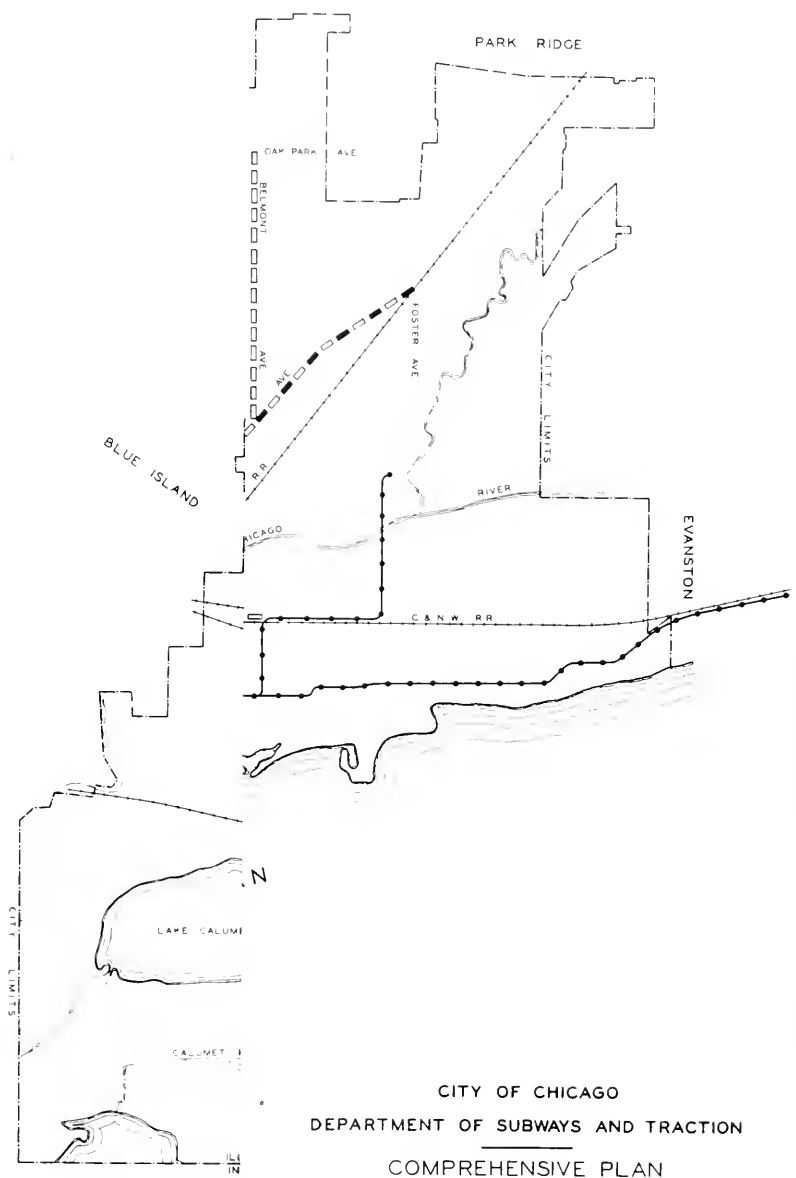
CITY OF CHICAGO
DEPARTMENT OF SUBWAYS AND TRACTION

A COMPREHENSIVE PLAN
FOR
THE EXTENSION OF THE SUBWAY SYSTEM.
INCLUDING PROVISION FOR THE WIDENING
OF E. CONGRESS STREET AND W. CONGRESS STREET
FROM S. MICHIGAN AVENUE WESTWARD
AND
FOR THE CONSTRUCTION OF A SUBWAY
IN W. CONGRESS STREET FROM
S. DEARBORN STREET WESTWARD

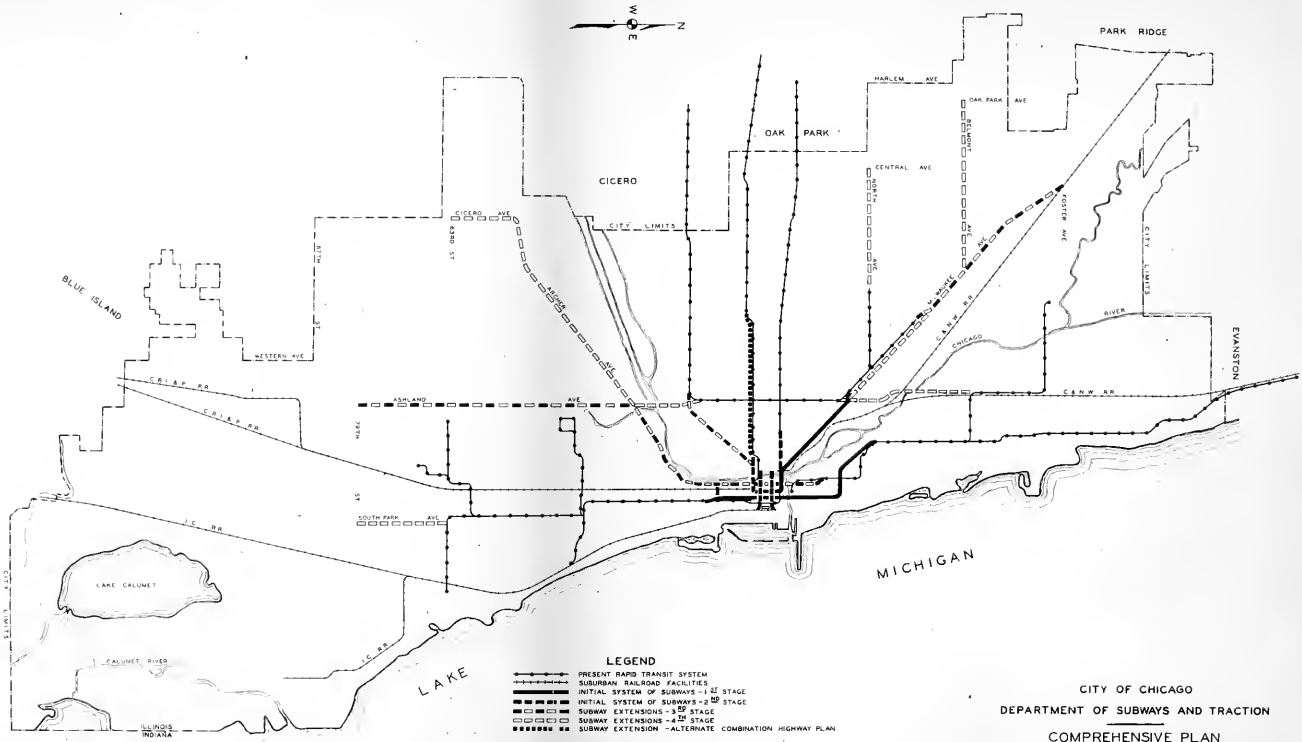
SEPTEMBER, 1939

LIST OF PLANS

- | | | |
|---|--|---|
| 1 - TITLE SHEET | 16 - PLAN AND PROFILE - CLINTON STREET TO WELLS STREET | 31 - DETAIL-KEDZIE AVENUE TO SACRAMENTO BOULEVARD |
| 2 - GENERAL PLAN - SUBWAY SYSTEM | 17 - PLAN AND PROFILE - HALSTED STREET TO CLINTON STREET | 32 - DETAIL AT GARFIELD PARK |
| 3 - GENERAL PLAN IN THE CENTRAL DISTRICT | 18 - PLAN AND PROFILE - ABERDEEN STREET TO HALSTED STREET | 33 - DETAIL- EXTENSION TO CITY LIMITS |
| 4 - PLAN AND PROFILE - CONGRESS ST EXTENSION TO DEARBORN ST SUBWAY | 19 - PLAN AND PROFILE - THROOP STREET TO ABERDEEN STREET | 34 - DETAIL AT COLUMBUS PARK |
| 5 - PLAN AND PROFILE - LAKE STREET SUBWAY | 20 - STRUCTURE - DESPLAINES STREET TO CANAL STREET | 35 - ALTERNATE-PLAN AND PROFILE - HALSTED STREET TO CLINTON STREET |
| 6 - PLAN AND PROFILE - WASHINGTON STREET SUBWAY | 21 - TYPICAL UNDERPASS THROUGH SOLID FILL SECTION | 36 - ALTERNATE-PLAN AND PROFILE - ABERDEEN STREET TO HALSTED STREET |
| 7 - PLAN AND PROFILE - JACKSON STREET SUBWAY | 22 - RECONSTRUCTION THROUGH LA SALLE STREET RAILROAD STATION | 37 - ALTERNATE-PLAN AND PROFILE - THROOP STREET TO ABERDEEN STREET |
| 8 - TYPICAL SECTIONS - LOW LEVEL SUBWAY | 23 - W CONGRESS STREET LIFT BRIDGE | 38 - ALTERNATE-PLAN AND PROFILE - KEDZIE AVENUE TO THROOP STREET |
| 9 - TYPICAL SECTIONS - HIGH LEVEL SUBWAY | 24 - W CONGRESS STREET FIXED BRIDGE | 39 - ALTERNATE-TYPICAL CROSS SECTIONS |
| 10 - TYPICAL LOW LEVEL STATION | 25 - W CONGRESS STREET BASCULE BRIDGE | 40 - ALTERNATE-DETAIL-OGDEN AVENUE TO ASHLAND BOULEVARD |
| 11 - TYPICAL HIGH LEVEL STATION WITH SIDE PLATFORMS | 26 - PLAN AND PROFILE - ST LOUIS AVENUE TO THROOP STREET | 41 - ALTERNATE-DETAIL-KEDZIE AVENUE TO SACRAMENTO BOULEVARD |
| 12 - PLAN AND SECTION - CLINTON STREET STATION - LAKE STREET SUBWAY | 27 - PLAN AND PROFILE - COLUMBUS PARK TO ST LOUIS AVENUE | 42 - ALTERNATE-DETAIL-ELEVATED INCLINES |
| 13 - GENERAL PLAN - CONGRESS STREET IMPROVEMENT | 28 - TYPICAL CROSS SECTIONS | 43 - PLAN SHOWING PROPERTY TO BE ACQUIRED |
| 14 - A SUGGESTED PLAN - STATE STREET TO MICHIGAN AVENUE | 29 - TYPICAL OVERPASS STRUCTURE | 44 - GENERAL PLAN SHOWING ALTERNATE ALIGNMENTS |
| 15 - PLAN AND PROFILE - WELLS STREET TO STATE STREET | 30 - DETAIL - WOLCOTT AVENUE TO MARSHFIELD AVENUE | |



CITY OF CHICAGO
 DEPARTMENT OF SUBWAYS AND TRACTION
 COMPREHENSIVE PLAN
 FOR THE
 EXTENSION OF THE SUBWAY SYSTEM
 GENERAL PLAN—SUBWAY SYSTEM
 SEPTEMBER, 1939

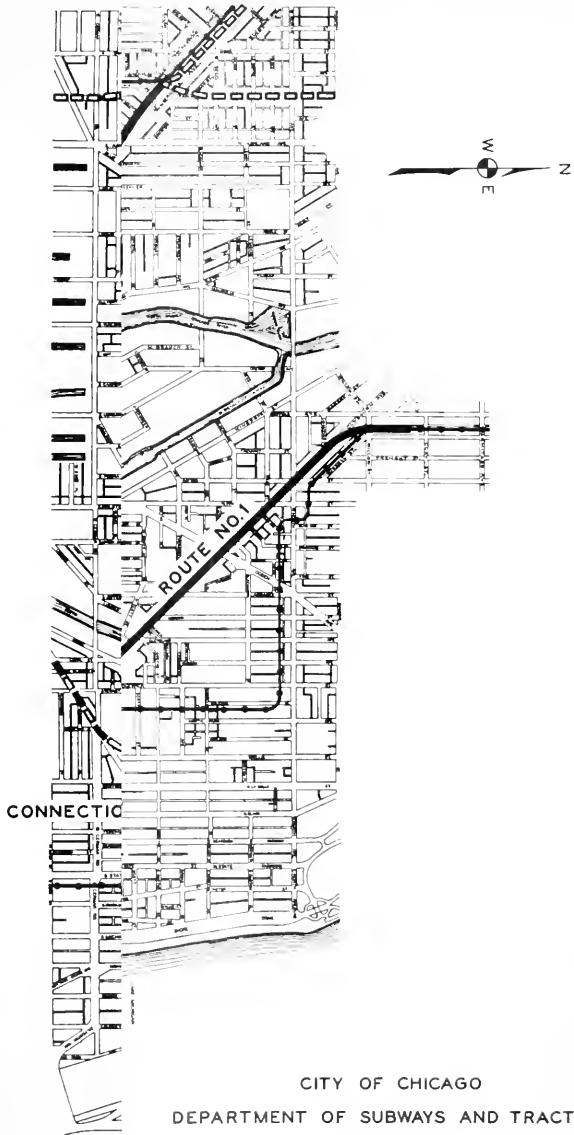


LEGEND

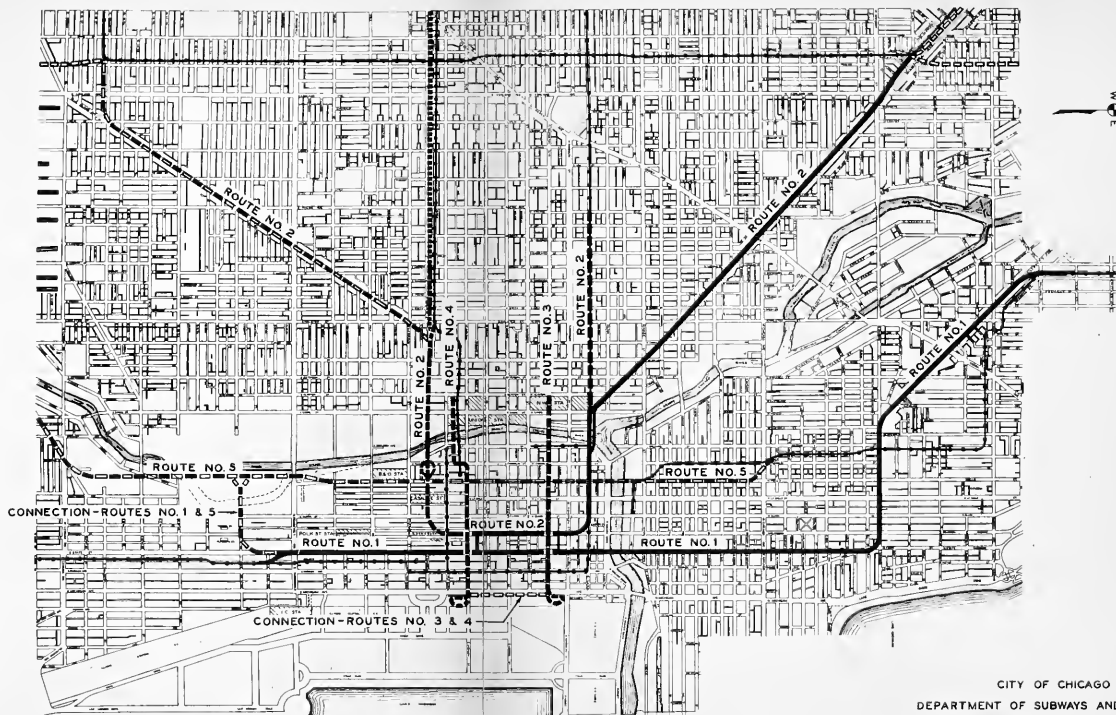
- PRESENT RAPID TRANSIT SYSTEM
- +—+—+—+— SUBURBAN RAILROAD FACILITIES
- INITIAL SYSTEM OF SUBWAYS—1ST STAGE
- INITIAL SYSTEM OF SUBWAYS—2ND STAGE
- ▨—▨—▨—▨— SUBWAY EXTENSIONS—3RD STAGE
- SUBWAY EXTENSIONS—4TH STAGE
- SUBWAY EXTENSION—ALTERNATE COMBINATION HIGHWAY PLAN



CITY OF CHICAGO
 DEPARTMENT OF SUBWAYS AND TRACTION
 COMPREHENSIVE PLAN
 FOR THE
 EXTENSION OF THE SUBWAY SYSTEM
 GENERAL PLAN—SUBWAY SYSTEM
 SEPTEMBER, 1939



CITY OF CHICAGO
 DEPARTMENT OF SUBWAYS AND TRACTION
 COMPREHENSIVE PLAN
 FOR THE
 EXTENSION OF THE SUBWAY SYSTEM
 GENERAL PLAN
 IN THE CENTRAL DISTRICT

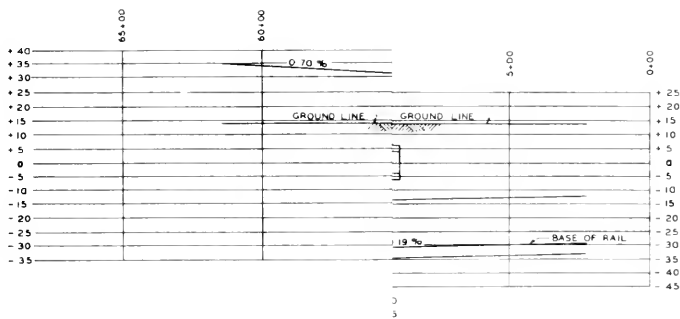
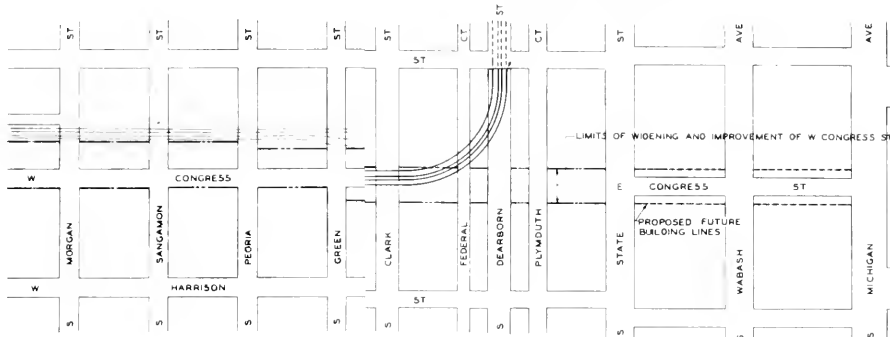


CITY OF CHICAGO
 DEPARTMENT OF SUBWAYS AND TRACTION
 COMPREHENSIVE PLAN
 FOR THE
 EXTENSION OF THE SUBWAY SYSTEM
 GENERAL PLAN
 IN THE CENTRAL DISTRICT

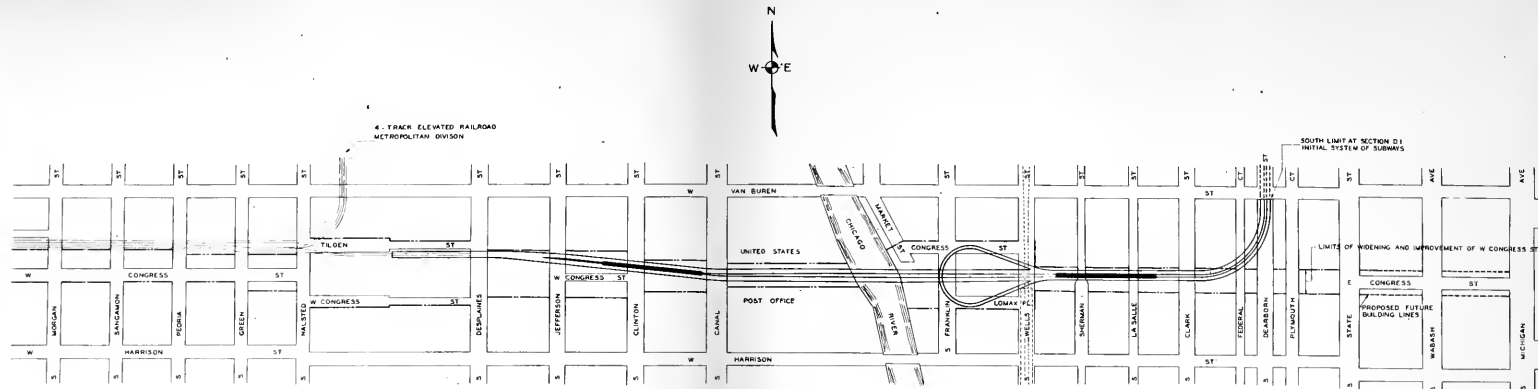
LEGEND

- - - - - PRESENT RAPID TRANSIT SYSTEM
 ——— INITIAL SYSTEM OF SUBWAYS - 1ST STAGE
 - - - - - INITIAL SYSTEM OF SUBWAYS - 2ND STAGE
 ▨▨▨▨▨ SUBWAY EXTENSIONS - 3RD STAGE
 ▤▤▤▤▤ SUBWAY EXTENSIONS - 4TH STAGE
 ▧▧▧▧▧ SUBWAY EXTENSIONS - ALTERNATE COMBINATION HIGHWAY PLAN
 SCALES IN FEET
 0 50 100 150

SOUTH LIMIT AT SECTION C.1
INITIAL SYSTEM OF SUBWAYS

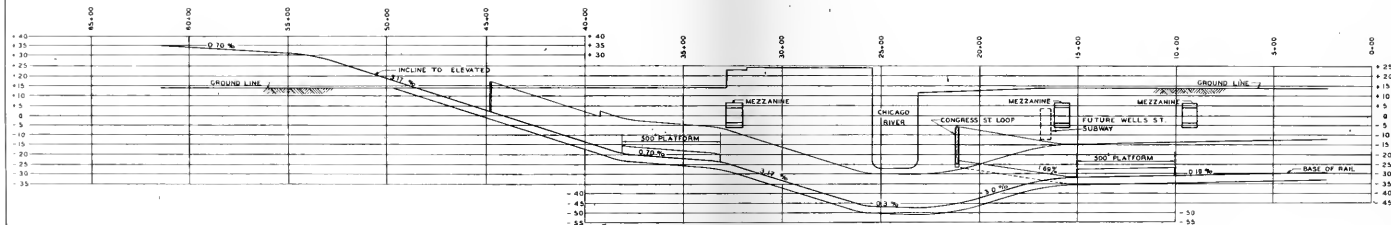


CITY OF CHICAGO
DEPARTMENT OF SUBWAYS AND TRACTION
COMPREHENSIVE PLAN
FOR THE
EXTENSION OF THE SUBWAY SYSTEM
I AND PROFILE CONGRESS STREET EXTENSION
TO DEARBORN STREET SUBWAY
SEPTEMBER, 1939



PLAN

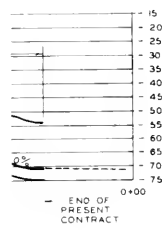
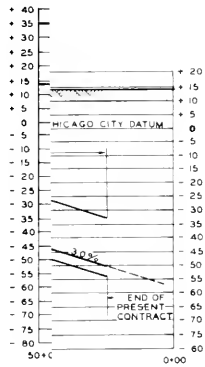
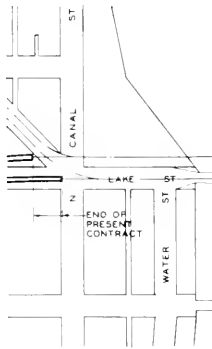
SCALE 0 50 100 200 400 FEET



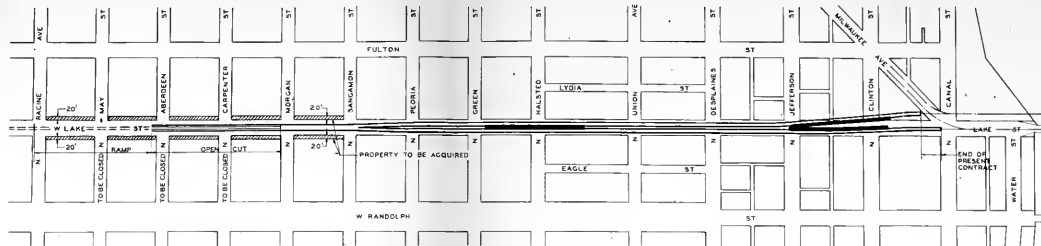
PROFILE

HORIZONTAL SCALE 0 50 100 200 400 FEET
 VERTICAL SCALE 0 3 10 25 40 FEET

CITY OF CHICAGO
 DEPARTMENT OF SUBWAYS AND TRACTION
 COMPREHENSIVE PLAN
 FOR THE
 EXTENSION OF THE SUBWAY SYSTEM
 PLAN AND PROFILE CONGRESS STREET EXTENSION
 TO DEARBORN STREET SUBWAY
 SEPTEMBER, 1939

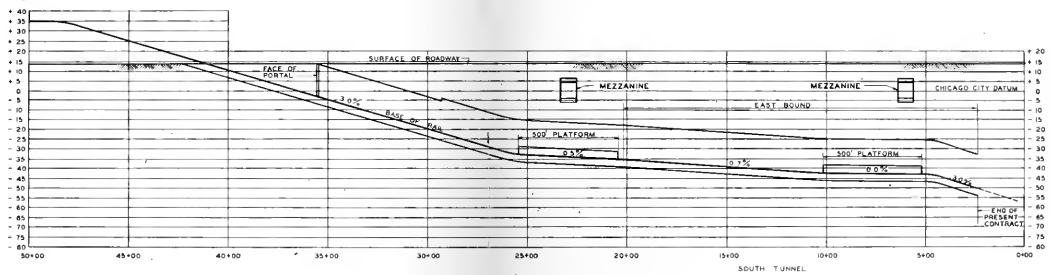


CITY OF CHICAGO
 DEPARTMENT OF SUBWAYS AND TRACTION
 COMPREHENSIVE PLAN
 FOR THE
 EXTENSION OF THE SUBWAY SYSTEM
 PLAN AND PROFILE
 LAKE ST. SUBWAY



PLAN

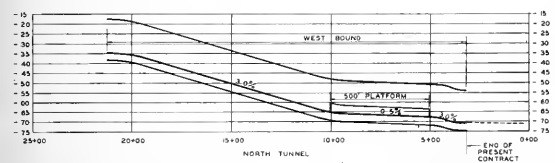
SCALE 0 100 200 400 FEET



PROFILE

HORIZONTAL SCALE 0 100 200 400 FEET

VERTICAL SCALE 0 5 10 20 40 FEET



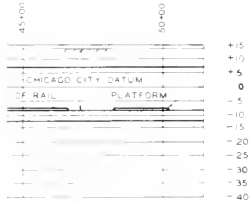
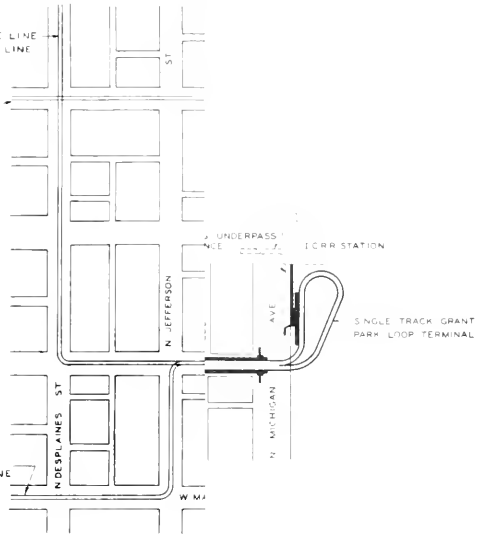
CITY OF CHICAGO
 DEPARTMENT OF SUBWAYS AND TRACTION
 COMPREHENSIVE PLAN
 FOR THE
 EXTENSION OF THE SUBWAY SYSTEM
 PLAN AND PROFILE
 LAKE ST. SUBWAY

STREET CAR LINES TO BE ROUTED THROUGH SUBWAY

MILWAUKEE LINE
 MILWAUKEE-ARMITAGE LINE
 DIVISION-MILWAUKEE LINE

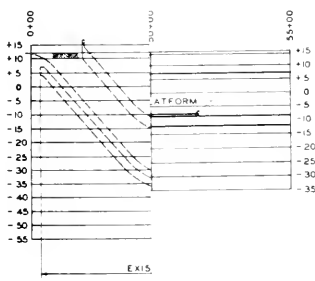
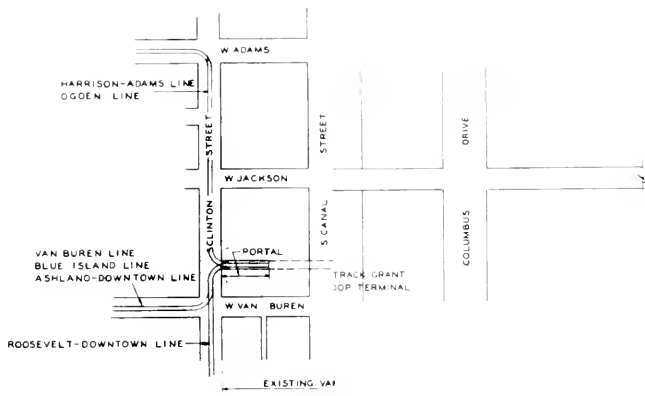
LAKE LINE

MADISON LINE
 MADISON-FIFTH LINE

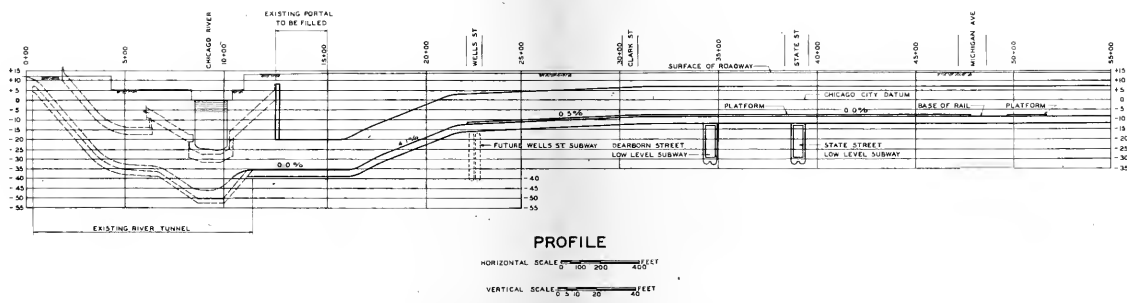
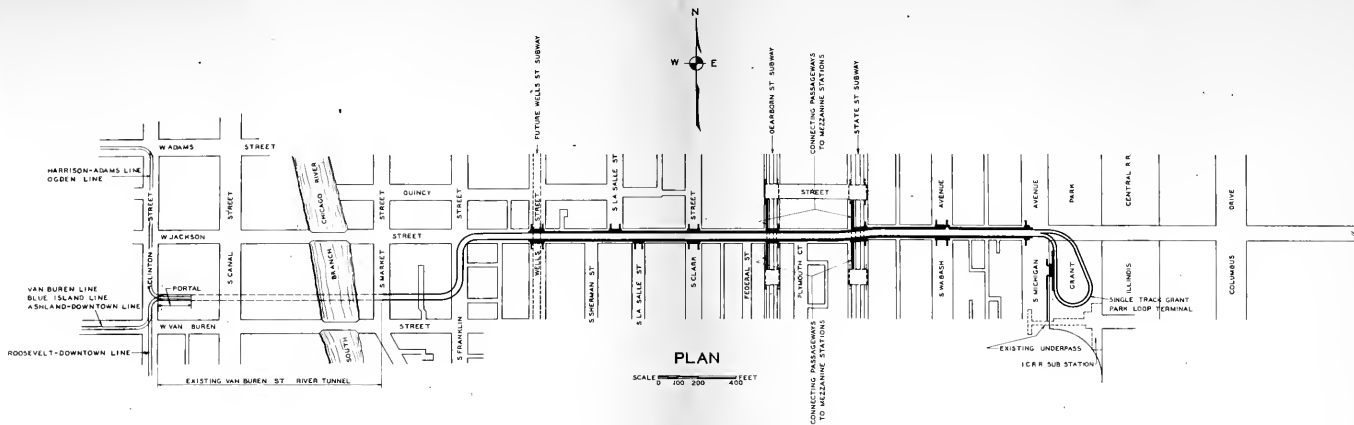


CITY OF CHICAGO
 DEPARTMENT OF SUBWAYS AND TRACTION
 COMPREHENSIVE PLAN
 FOR THE
 EXTENSION OF THE SUBWAY SYSTEM
 PLAN AND PROFILE WASHINGTON ST. SUBWAY
 SEPTEMBER, 1939

STREET CAR LINES TO BE ROUTED THROUGH SUBWAY

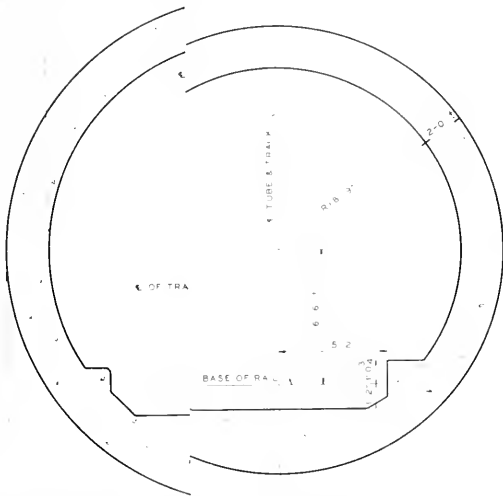


CITY OF CHICAGO
 DEPARTMENT OF SUBWAYS AND TRACTION
 COMPREHENSIVE PLAN
 FOR THE
 EXTENSION OF THE SUBWAY SYSTEM
 PLAN AND PROFILE JACKSON ST. SUBWAY
 SEPTEMBER, 1939

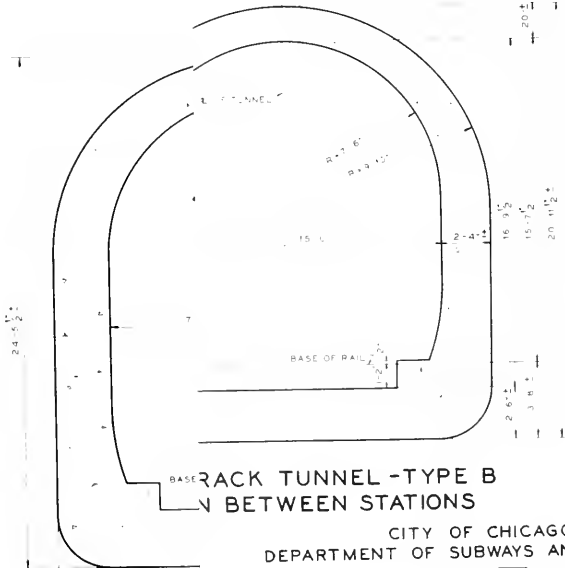


CITY OF CHICAGO
DEPARTMENT OF SUBWAYS AND TRACTION
COMPREHENSIVE PLAN
FOR THE
EXTENSION OF THE SUBWAY SYSTEM
PLAN AND PROFILE JACKSON ST. SUBWAY
SEPTEMBER, 1939

2'-0" 10'-2 1/2"

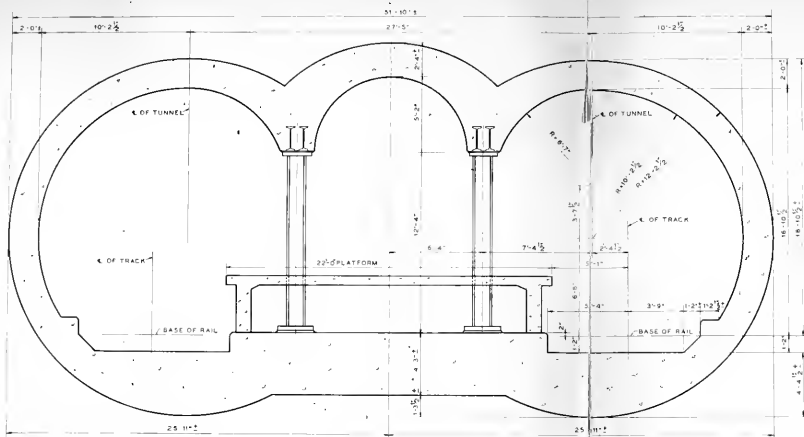


RACK TUNNEL-TYPE A
N BETWEEN STATIONS

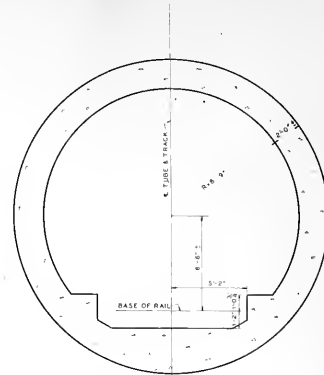


RACK TUNNEL-TYPE B
N BETWEEN STATIONS

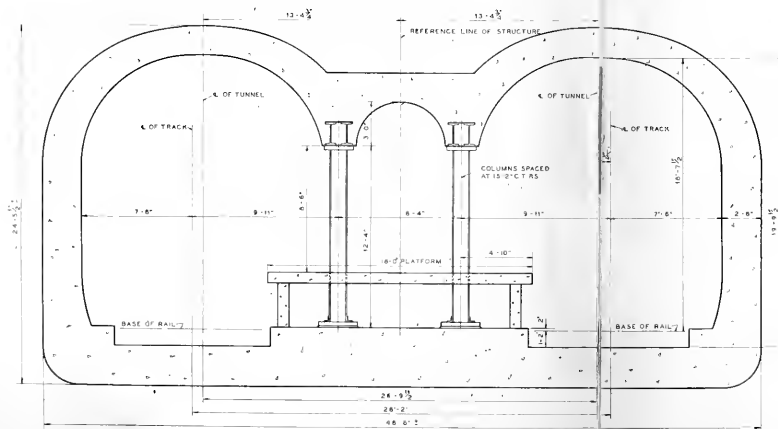
CITY OF CHICAGO
 DEPARTMENT OF SUBWAYS AND TRACTION
 COMPREHENSIVE PLAN
 FOR THE
 EXTENSION OF THE SUBWAY SYSTEM
 TYPICAL SECTIONS LOW LEVEL SUBWAY
 SEPTEMBER, 1939



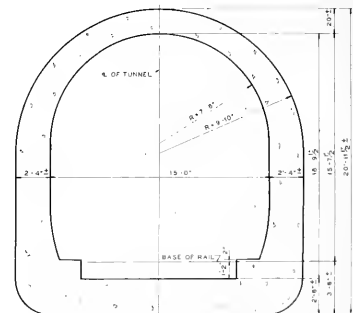
SECTION AT STATIONS - TYPE A
DIMENSIONS FOR 22 FOOT ISLAND PLATFORM



SINGLE TRACK TUNNEL - TYPE A
SECTION BETWEEN STATIONS

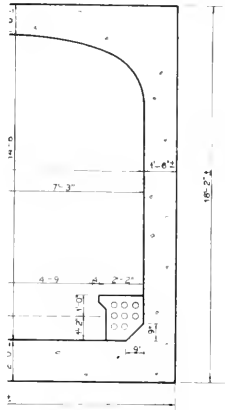


SECTION AT STATIONS - TYPE B
DIMENSIONS FOR 18 FOOT ISLAND PLATFORM

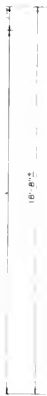


SINGLE TRACK TUNNEL - TYPE B
SECTION BETWEEN STATIONS

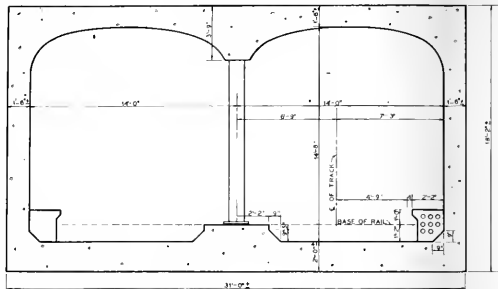
CITY OF CHICAGO
DEPARTMENT OF SUBWAYS AND TRACTION
COMPREHENSIVE PLAN
FOR THE
EXTENSION OF THE SUBWAY SYSTEM
TYPICAL SECTIONS LOW LEVEL SUBWAY
SEPTEMBER, 1939



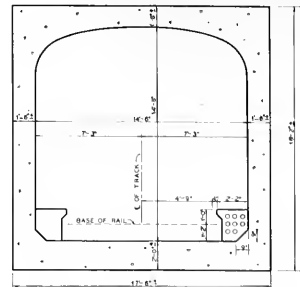
SECTION BETWEEN STATIONS
CONSTRUCTION



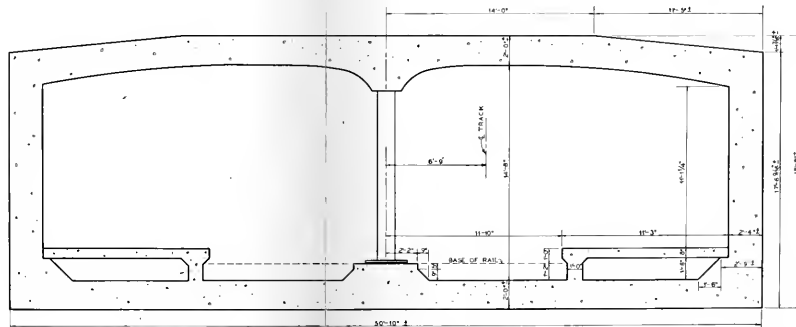
CITY OF CHICAGO
 DEPARTMENT OF SUBWAYS AND TRACTION
 COMPREHENSIVE PLAN
 FOR THE
 EXTENSION OF THE SUBWAY SYSTEM
 TYPICAL SECTIONS HIGH LEVEL SUBWAY
 SEPTEMBER, 1939



TWO TRACK HIGH LEVEL SECTION BETWEEN STATIONS
OPEN CUT CONSTRUCTION

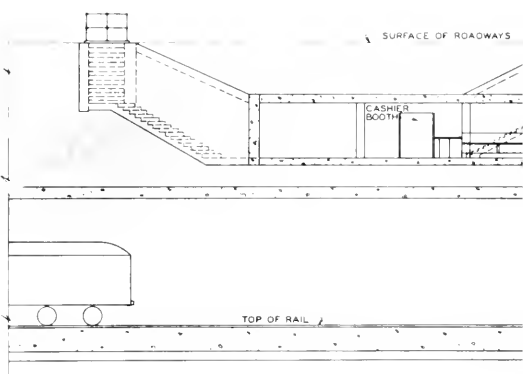
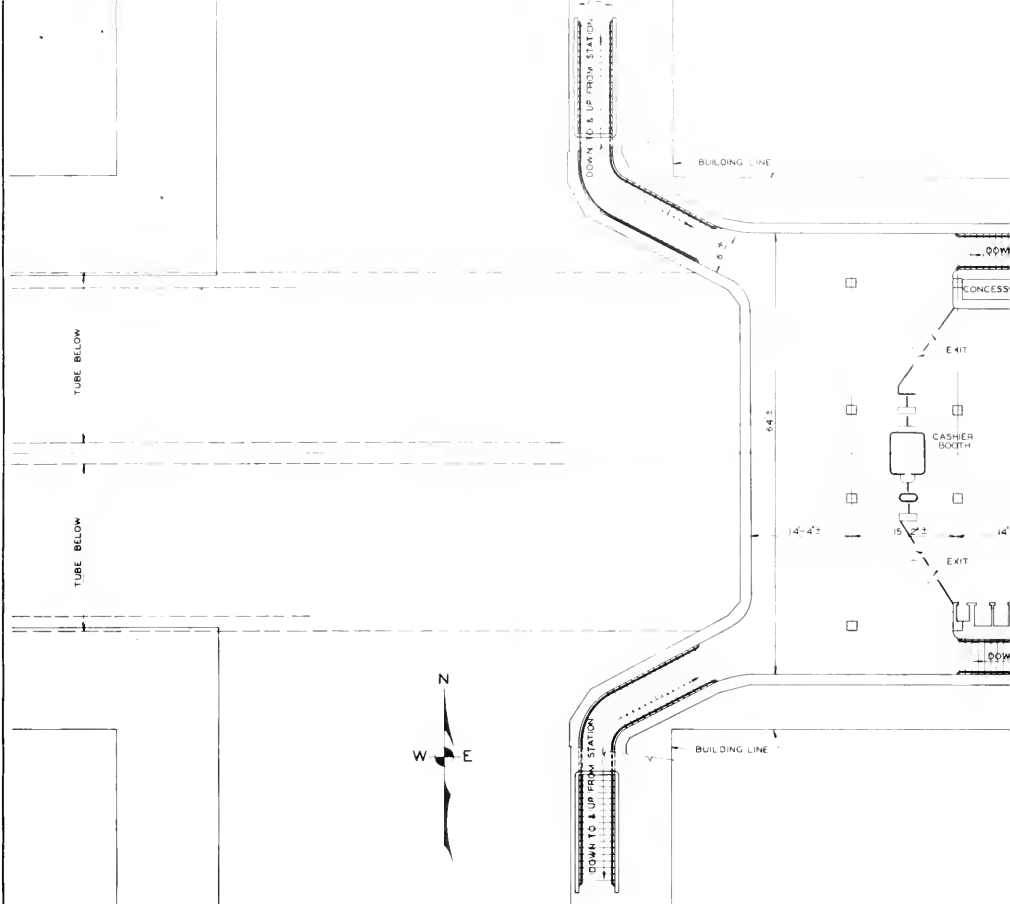


SINGLE TRACK HIGH LEVEL SECTION BETWEEN STATIONS
OPEN CUT CONSTRUCTION

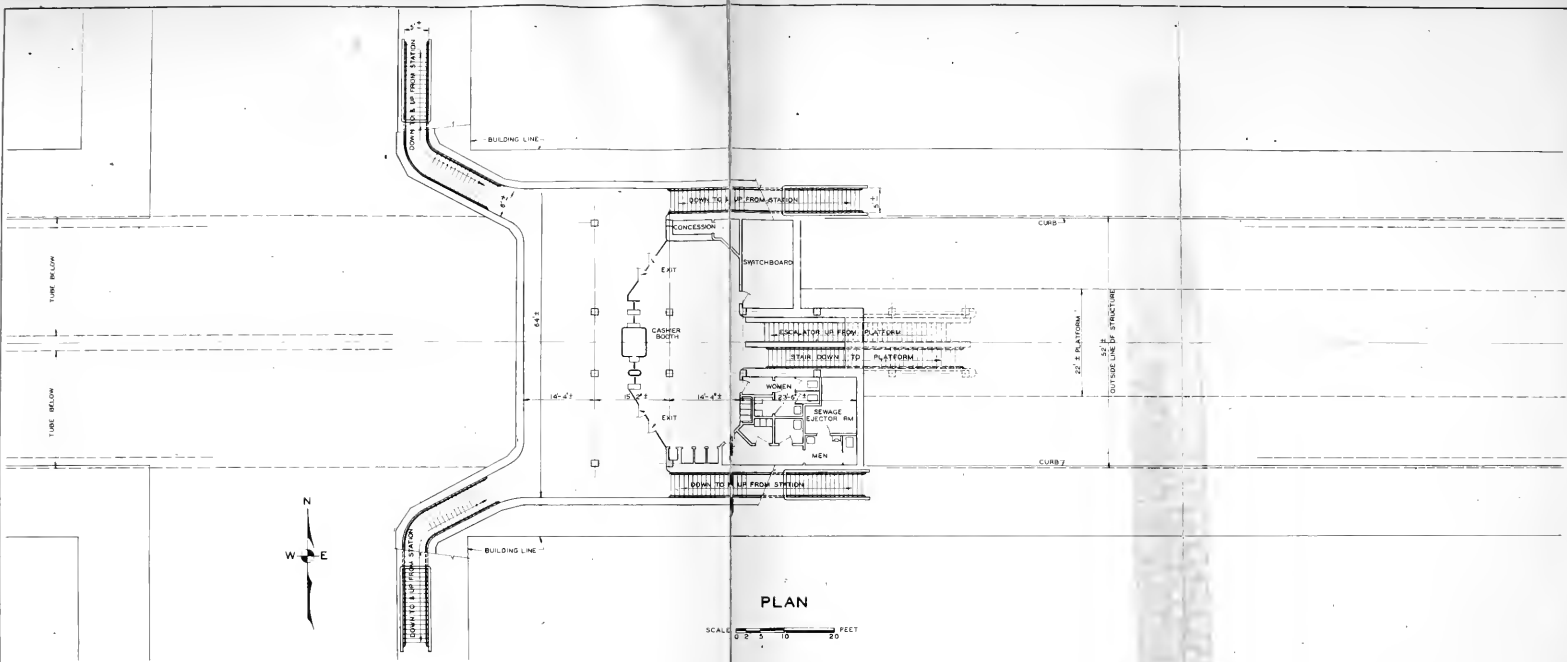


TWO TRACK HIGH LEVEL SIDE PLATFORM STATION SECTION
OPEN CUT CONSTRUCTION

CITY OF CHICAGO
DEPARTMENT OF SUBWAYS AND TRACTION
COMPREHENSIVE PLAN
FOR THE
EXTENSION OF THE SUBWAY SYSTEM
TYPICAL SECTIONS HIGH LEVEL SUBWAY
SEPTEMBER, 1939

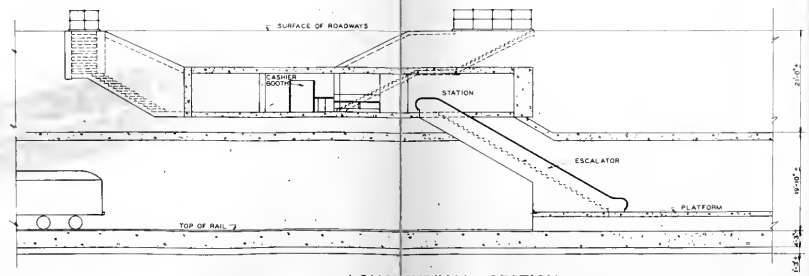


LONG



PLAN

SCALE 0 2 5 10 20 FEET



LONGITUDINAL SECTION

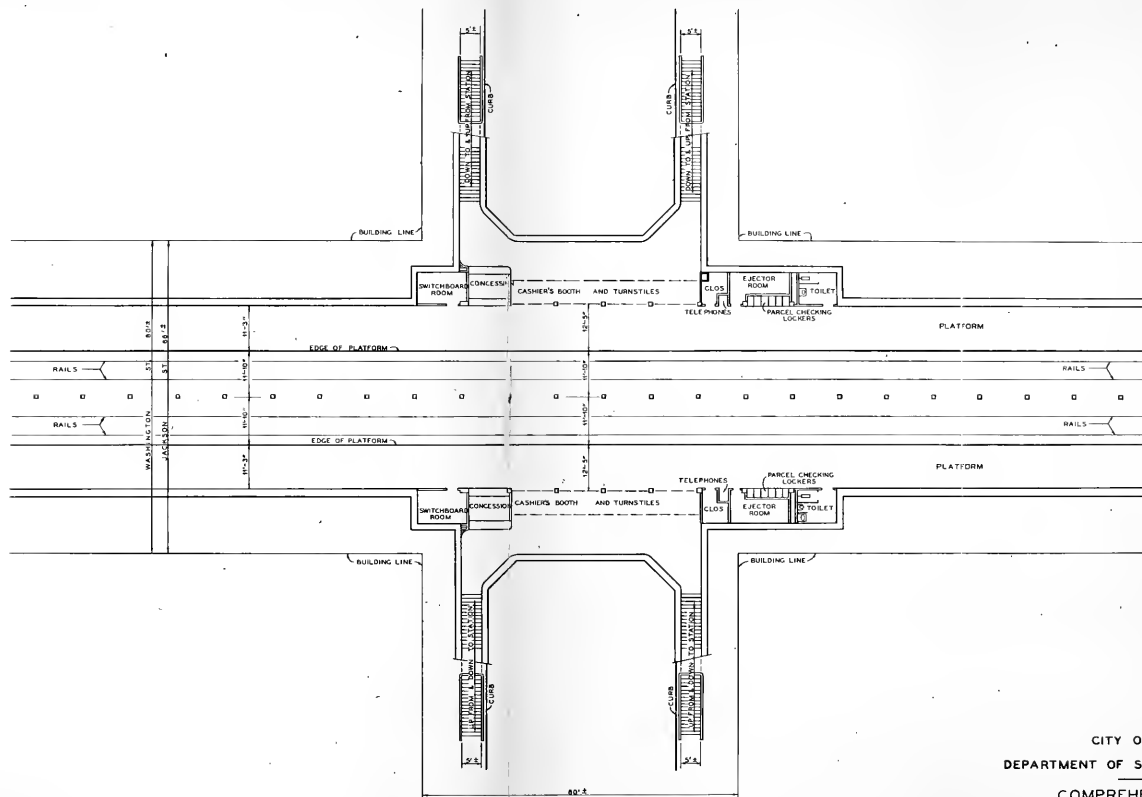
CITY OF CHICAGO
 DEPARTMENT OF SUBWAYS AND TRACTION
 COMPREHENSIVE PLAN
 FOR THE
 EXTENSION OF THE SUBWAY SYSTEM
 TYPICAL LOW LEVEL STATION

SEPTEMBER, 1939



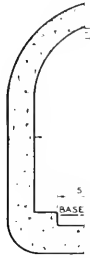




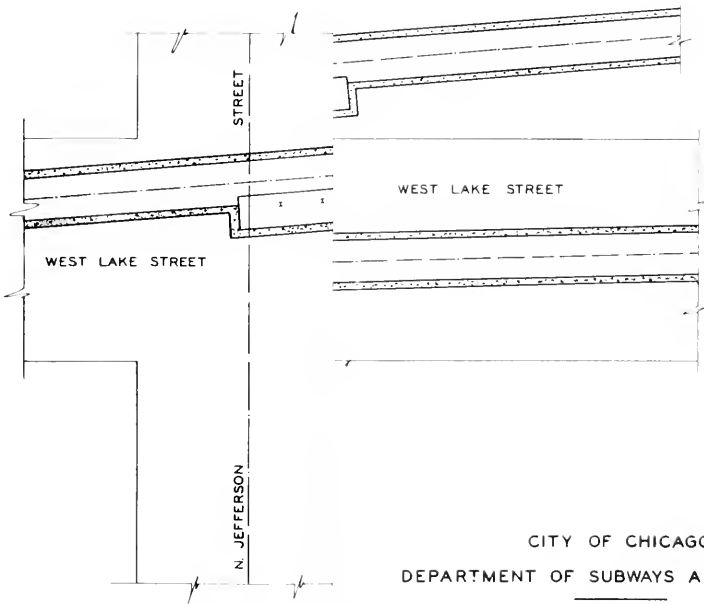


SCALE 0 5 10 20 FEET

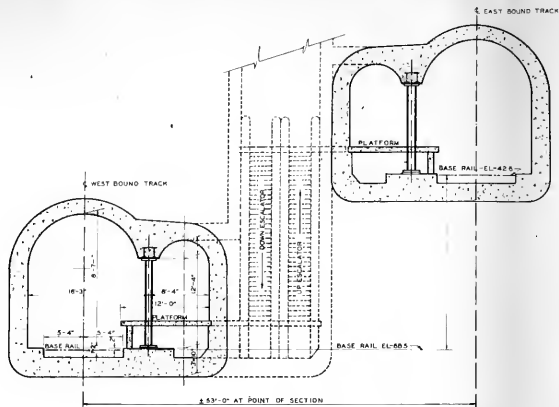
CITY OF CHICAGO
 DEPARTMENT OF SUBWAYS AND TRACTION
 COMPREHENSIVE PLAN
 FOR THE
 EXTENSION OF THE SUBWAY SYSTEM
 TYPICAL HIGH LEVEL STATION
 WITH SIDE PLATFORMS
 SEPTEMBER, 1939



SI

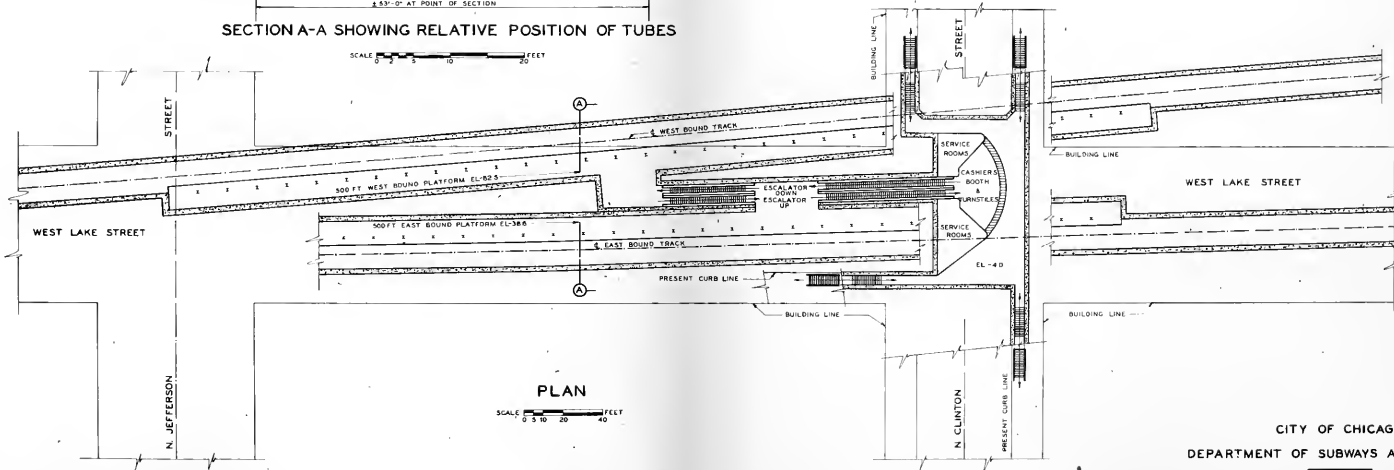


CITY OF CHICAGO
 DEPARTMENT OF SUBWAYS AND TRACTION
 COMPREHENSIVE PLAN
 FOR THE
 EXTENSION OF THE SUBWAY SYSTEM
 LAKE ST.
 PLAN AND SECTION CLINTON ST. STATION
 SEPTEMBER, 1939



SECTION A-A SHOWING RELATIVE POSITION OF TUBES

SCALE 0 5 10 20 FEET

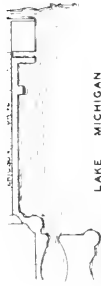


PLAN

SCALE 0 5 10 20 40 FEET



CITY OF CHICAGO
 DEPARTMENT OF SUBWAYS AND TRACTION
 COMPREHENSIVE PLAN
 FOR THE
 EXTENSION OF THE SUBWAY SYSTEM
 LAKE ST.
 PLAN AND SECTION CLINTON ST. STATION
 SEPTEMBER, 1939

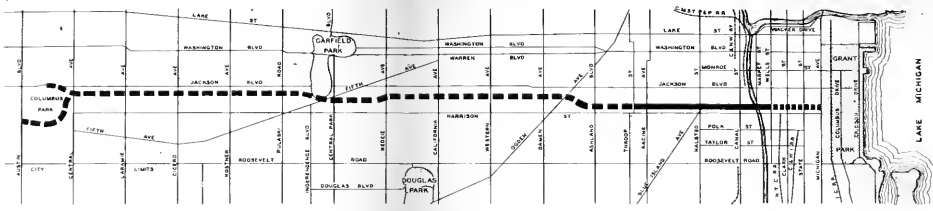


CITY OF CHICAGO
DEPARTMENT OF SUBWAYS AND TRACTION

PLANNING AND IMPROVEMENT
OF CONGRESS STREET

PLAN - CONGRESS STREET IMPROVEMENT

SEPTEMBER, 1939

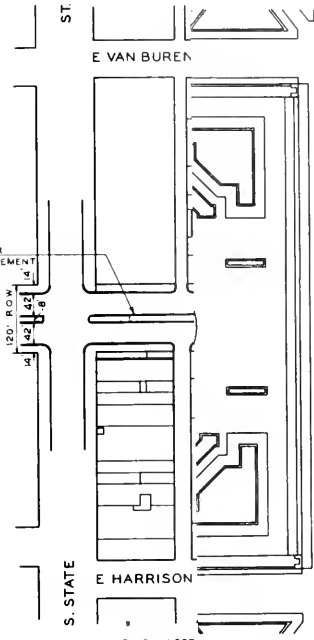


PROVISION FOR THE WIDENING AND IMPROVEMENT OF E. CONGRESS STREET AND W. CONGRESS STREET FROM S. MICHIGAN AVENUE TO THROOP STREET, AND A SUGGESTION FOR THE DEVELOPMENT OF A WEST SIDE SUPERHIGHWAY WEST OF THROOP ST. TO ACCOMPANY A COMPREHENSIVE PLAN FOR EXTENSION OF THE SUBWAY SYSTEM (P.W.A. PROJECT ILL 1891-F)



CITY OF CHICAGO
 DEPARTMENT OF SUBWAYS AND TRACTION
 WIDENING AND IMPROVEMENT
 OF CONGRESS STREET
 GENERAL PLAN - CONGRESS STREET IMPROVEMENT
 SEPTEMBER, 1939

SEE SHEET IS FOR
TEMPORARY IMPROVEMENT

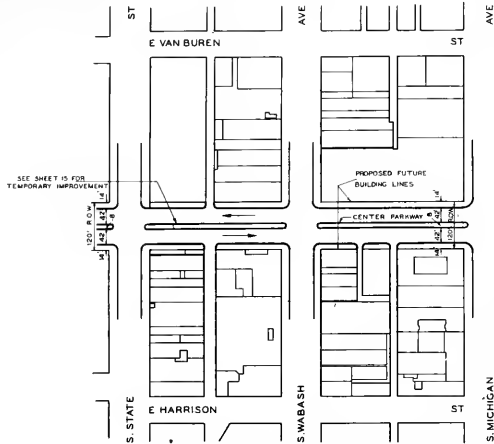


DRIVE

LEIF ERIKSEN (OUTER)

LAKE MICHIGAN

CITY OF CHICAGO
DEPARTMENT OF SUBWAYS AND TRACTION
WIDENING AND IMPROVEMENT
OF CONGRESS STREET
A SUGGESTED PLAN
STATE STREET TO MICHIGAN AVE.



SEE SHEET 15 FOR
TEMPORARY IMPROVEMENT

120' R.O.W.
14'

S. STATE

ST

E VAN BUREN

AVE

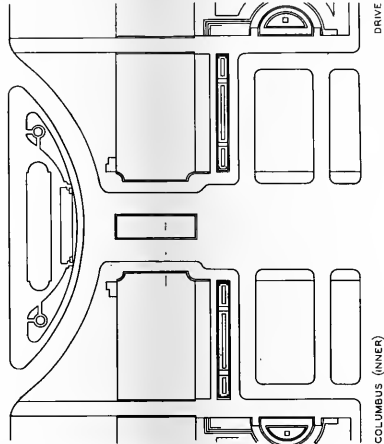
ST

E HARRISON

S. WABASH

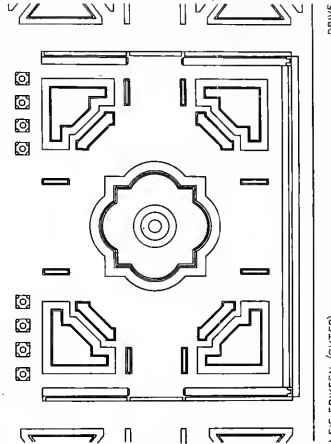
S. MICHIGAN

ROADWAY BETWEEN S. STATE ST. AND S. MICHIGAN AVE. TO BE WIDENED TO 50 FEET INITIALLY. THE SUGGESTED PLAN TO BE BUILT WHEN EVER WIDENED RIGHT OF WAY IS ACQUIRED.



TREATMENT OF CONNECTING ROADWAYS
IN GRANT PARK TO BE DETERMINED
BY CHICAGO PARK DISTRICT

COLUMBUS (INNER)
DRIVE

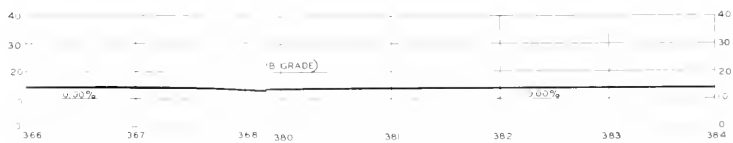
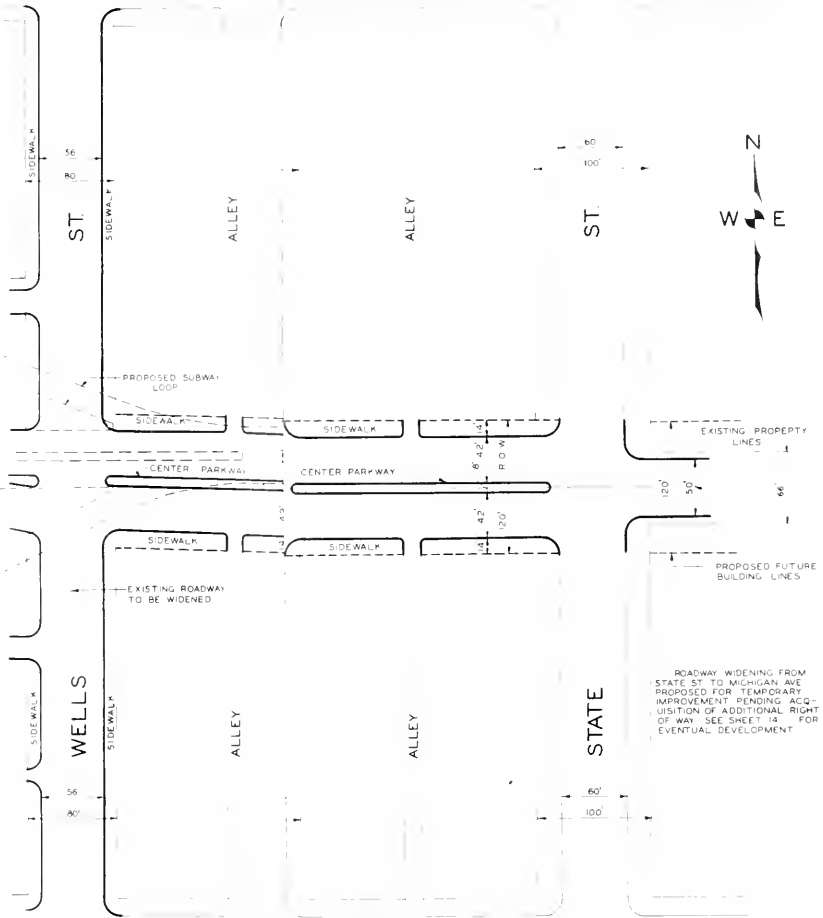


LEIF ERIKSEN (OUTER)
DRIVE

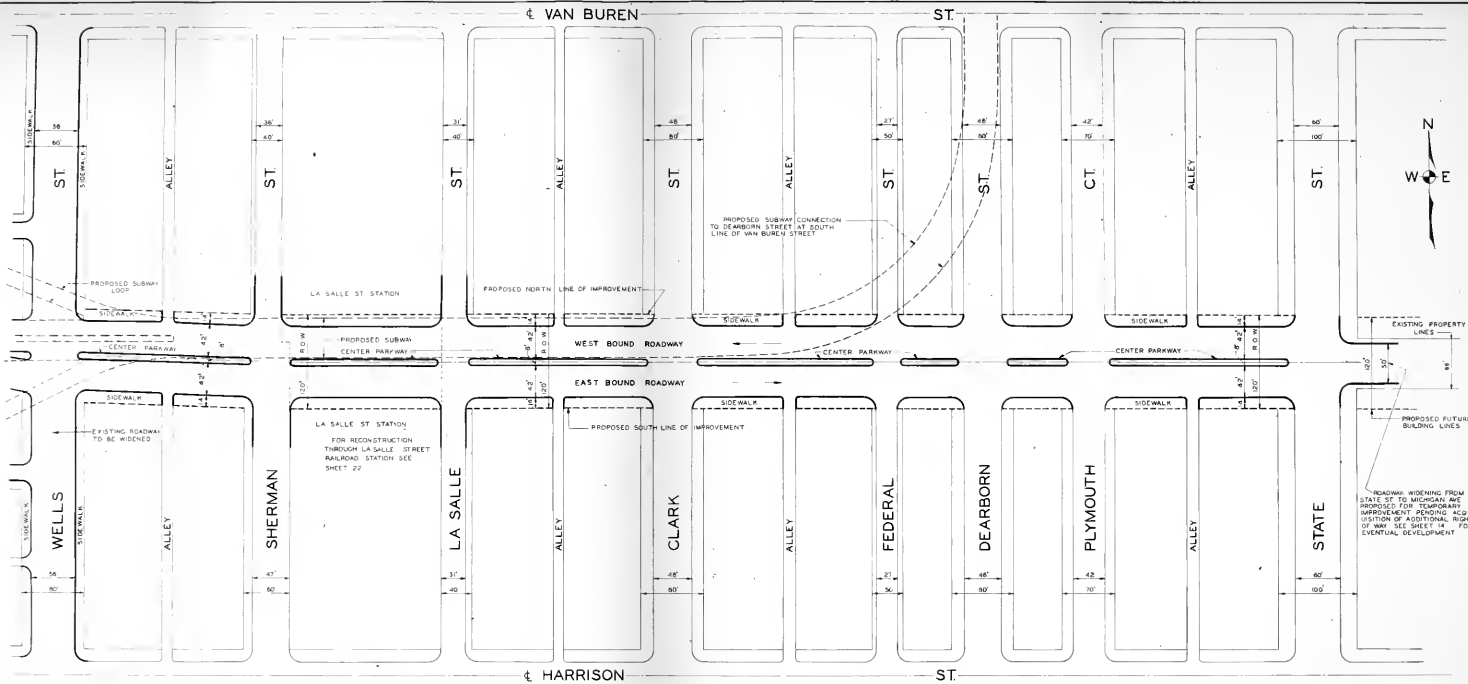
LAKE
MICHIGAN

SCALE 0 50 100 200 FEET

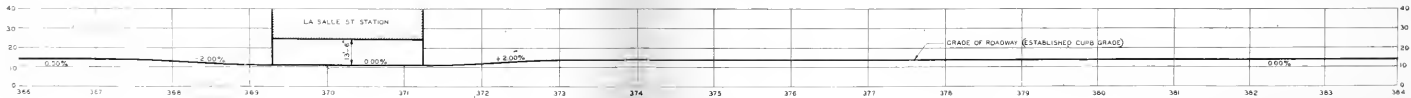
CITY OF CHICAGO
DEPARTMENT OF SUBWAYS AND TRACTION
WIDENING AND IMPROVEMENT
OF CONGRESS STREET
A SUGGESTED PLAN
STATE STREET TO MICHIGAN AVE.



CITY OF CHICAGO
 DEPARTMENT OF SUBWAYS AND TRACTION
 WIDENING AND IMPROVEMENT
 CONGRESS STREET
 PLAN AND PROFILE
 WELLS ST. TO STATE ST.
 SEPTEMBER, 1939



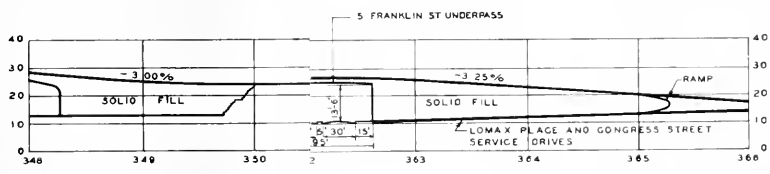
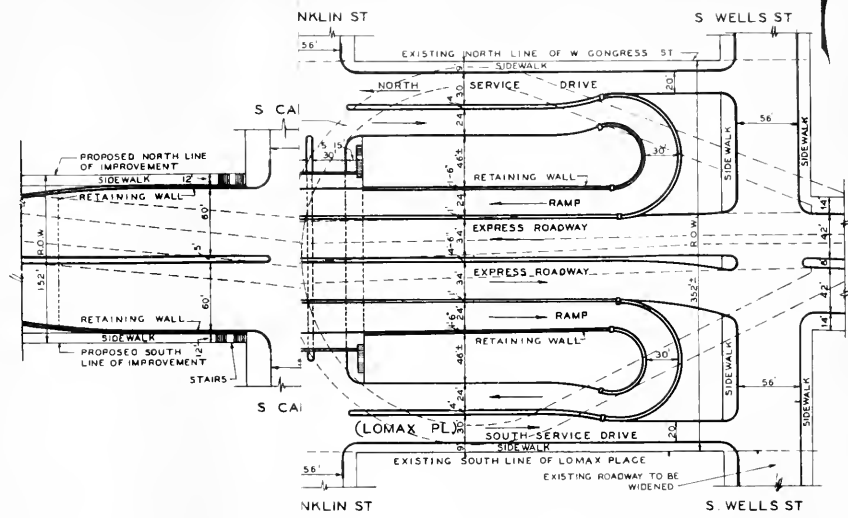
PLAN
SCALE 0 50 100 FEET



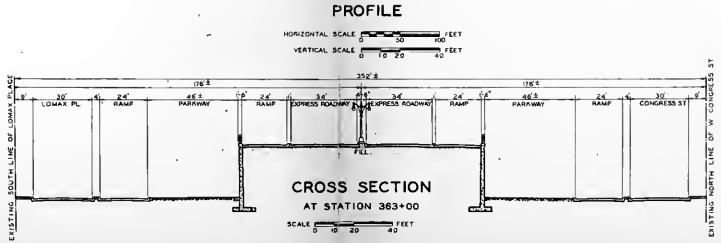
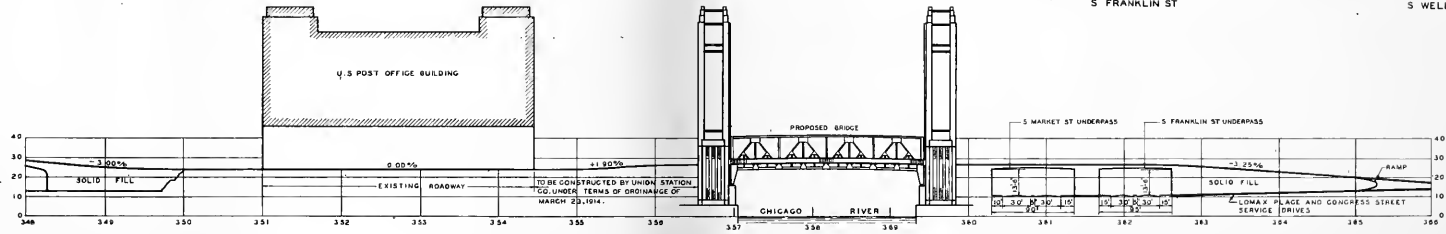
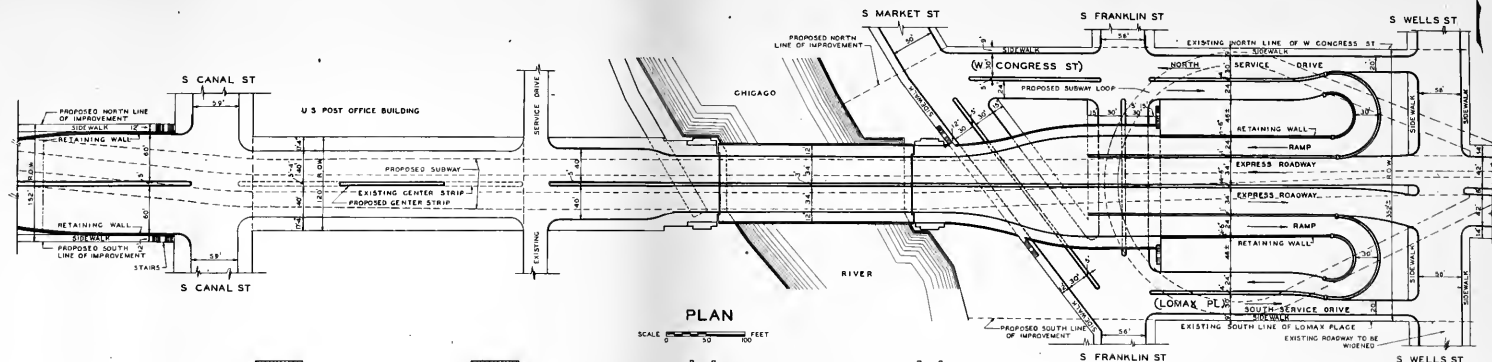
PROFILE
HORIZONTAL SCALE 0 50 100 FEET
VERTICAL SCALE 0 10 20 40 FEET

CITY OF CHICAGO
DEPARTMENT OF SUBWAYS AND TRACTION
WIDENING AND IMPROVEMENT
CONGRESS STREET

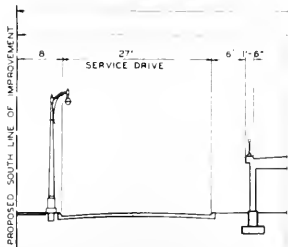
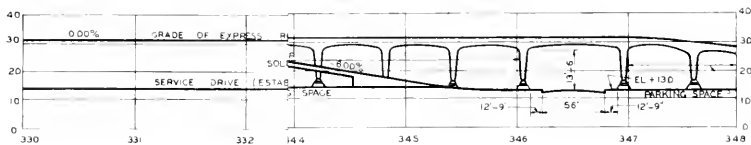
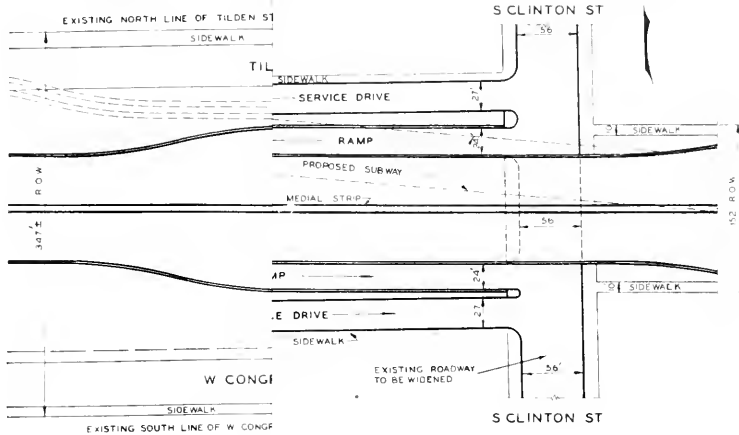
PLAN AND PROFILE
WELLS ST. TO STATE ST
SEPTEMBER, 1939



CITY OF CHICAGO
 DEPARTMENT OF SUBWAYS AND TRACTION
 WIDENING AND IMPROVEMENT
 OF CONGRESS STREET
 PLAN AND PROFILE
 CLINTON ST. TO WELLS ST.
 SEPTEMBER, 1939



CITY OF CHICAGO
DEPARTMENT OF SUBWAYS AND TRACTION
WIDENING AND IMPROVEMENT
OF CONGRESS STREET
PLAN AND PROFILE
CLINTON ST. TO WELLS ST.
SEPTEMBER, 1939

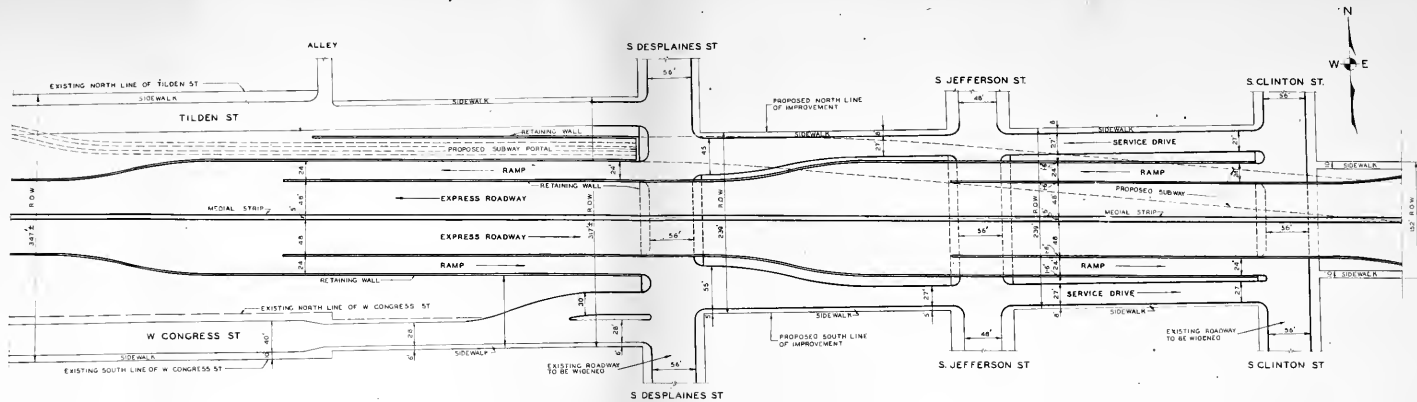


CITY OF CHICAGO
DEPARTMENT OF SUBWAYS AND TRACTION

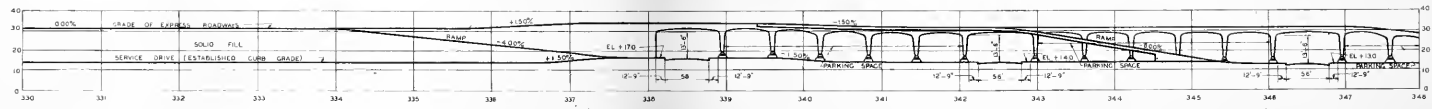
WIDENING AND IMPROVEMENT
OF CONGRESS STREET

PLAN AND PROFILE
HALSTED ST. TO CLINTON ST.

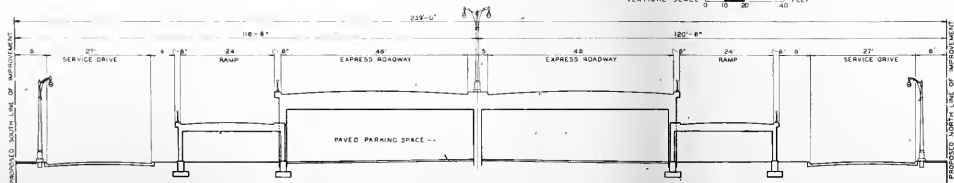
SEPTEMBER, 1939



PLAN
SCALE 0 50 100 FEET



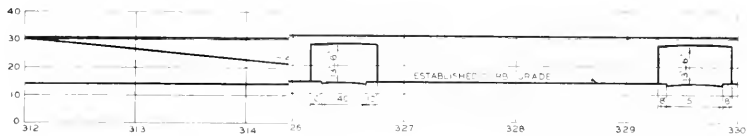
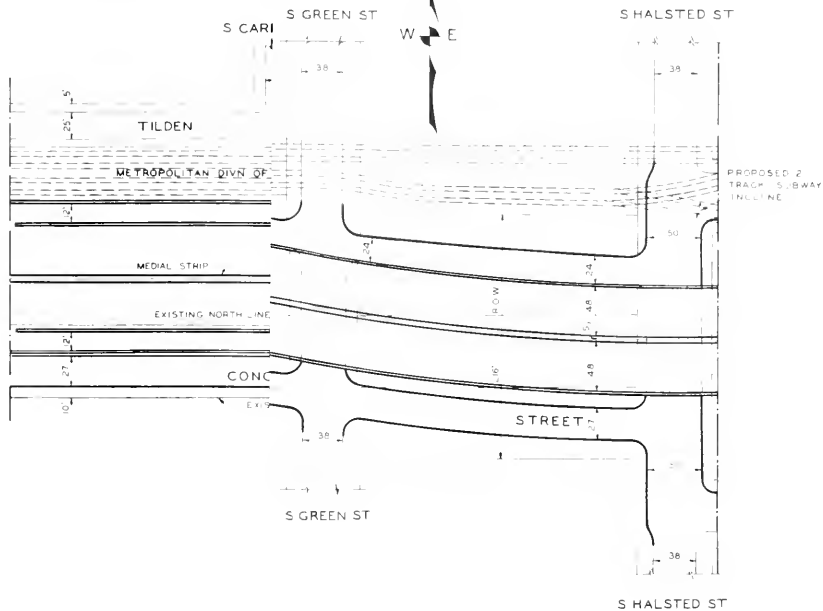
PROFILE
HORIZONTAL SCALE 0 30 150 FEET
VERTICAL SCALE 0 10 20 40 FEET



CROSS SECTION
AT STATION 344+00
SCALE 0 20 40 FEET

CITY OF CHICAGO
DEPARTMENT OF SUBWAYS AND TRACTION
WIDENING AND IMPROVEMENT
OF CONGRESS STREET

PLAN AND PROFILE
HALSTED ST. TO CLINTON ST.
SEPTEMBER, 1939

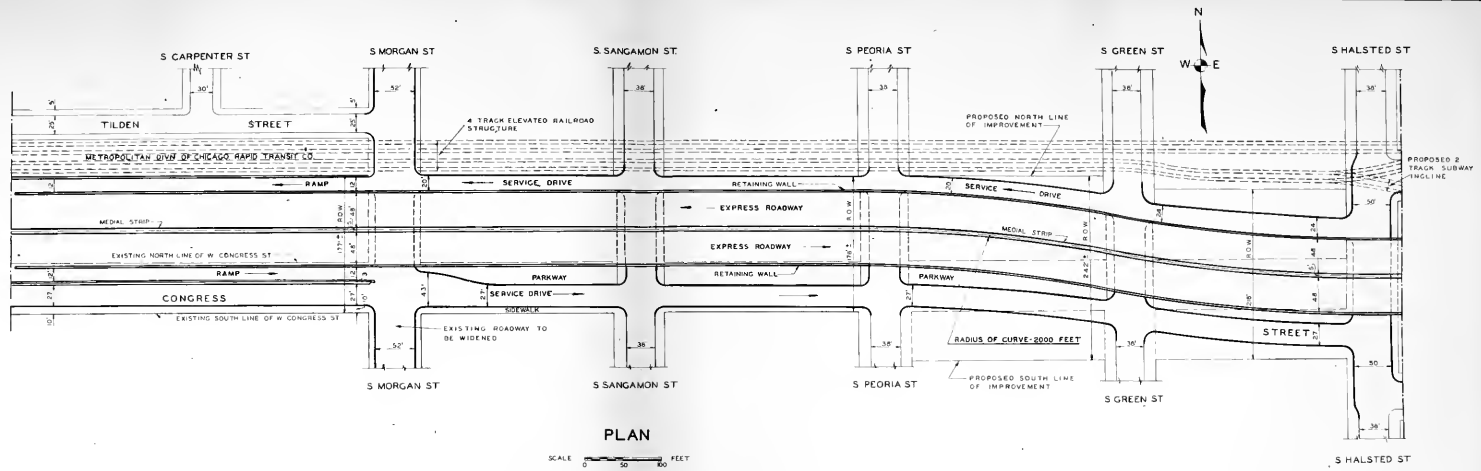


CITY OF CHICAGO
DEPARTMENT OF SUBWAYS AND TRACTION

WIDENING AND IMPROVEMENT
OF CONGRESS STREET

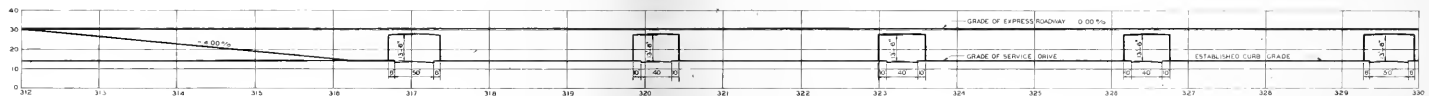
PLAN AND PROFILE
ABERDEEN ST TO HALSTED ST

SEPTEMBER, 1939



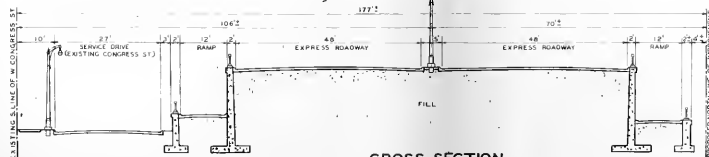
PLAN

SCALE 0 30 60 FEET



PROFILE

HORIZONTAL SCALE 0 30 60 FEET
 VERTICAL SCALE 0 20 40 FEET



CROSS SECTION
 AT STATION 315+00

SCALE 0 5 10 20 FEET

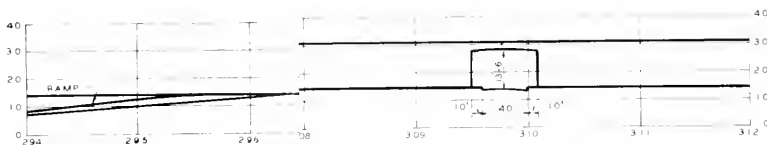
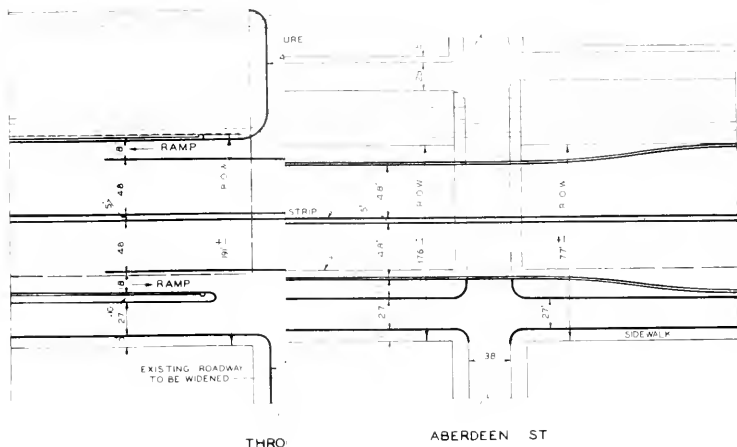
CITY OF CHICAGO
 DEPARTMENT OF SUBWAYS AND TRACTION
 WIDENING AND IMPROVEMENT
 OF CONGRESS STREET

PLAN AND PROFILE
 ABERDEEN ST TO HALSTED ST.
 SEPTEMBER, 1939

THRO

ABERDEEN ST

W E

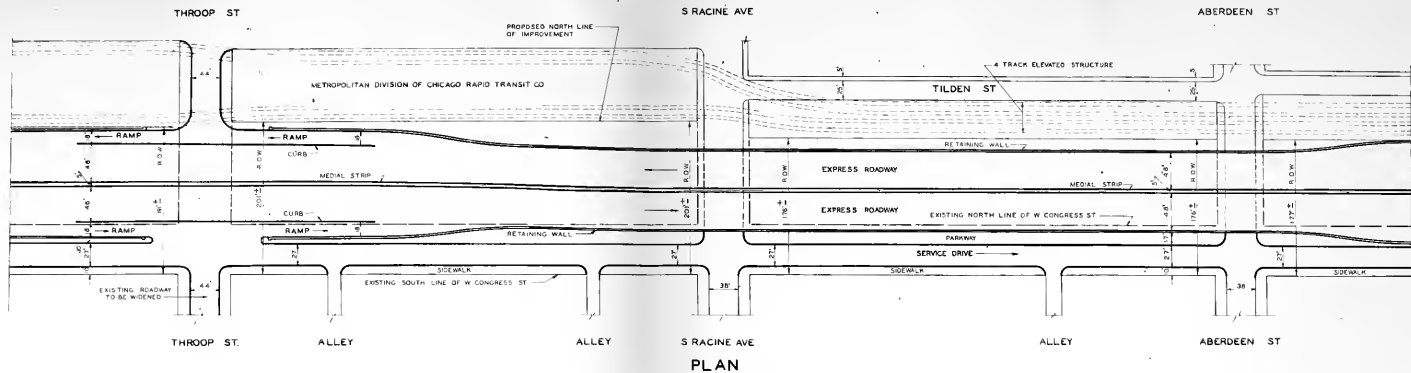


CITY OF CHICAGO
 DEPARTMENT OF SUBWAYS AND TRACTION

WIDENING AND IMPROVEMENT
 OF CONGRESS STREET

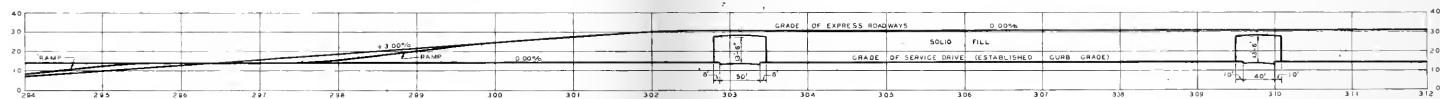
PLAN AND PROFILE
 THROOP ST. TO ABERDEEN ST.

SEPTEMBER, 1939



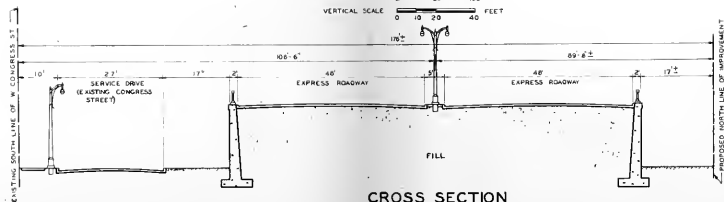
PLAN

SCALE 0 50 100 FEET



PROFILE

HORIZONTAL SCALE 0 50 100 FEET
 VERTICAL SCALE 0 10 20 30 40 FEET



CROSS SECTION

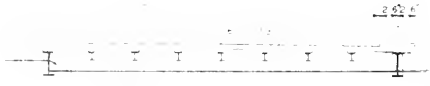
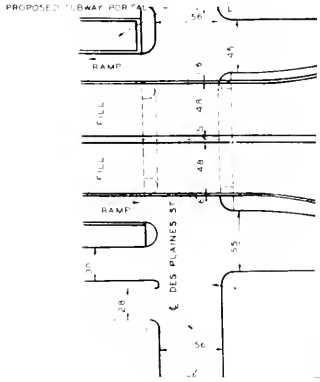
AT STATION 304+00

SCALE 0 10 20 FEET

CITY OF CHICAGO
 DEPARTMENT OF SUBWAYS AND TRACTION
 WIDENING AND IMPROVEMENT
 OF CONGRESS STREET

PLAN AND PROFILE
 THROOP ST. TO ABERDEEN ST.

SEPTEMBER, 1939

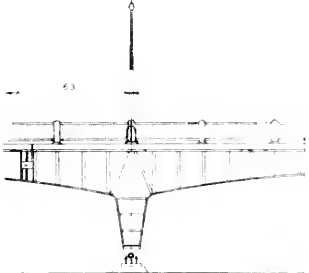


1/2" = 10'
1/4" = 5'

24.00'

STRUCTURE
SYMMETRICAL ABOUT
THIS C-E

CROSS-SECTION B-B

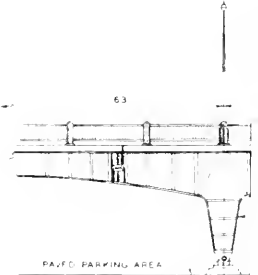


1/2" = 10'
1/4" = 5'



STRUCTURE
SYMMETRICAL ABOUT
THIS C-E

CROSS-SECTION A-A

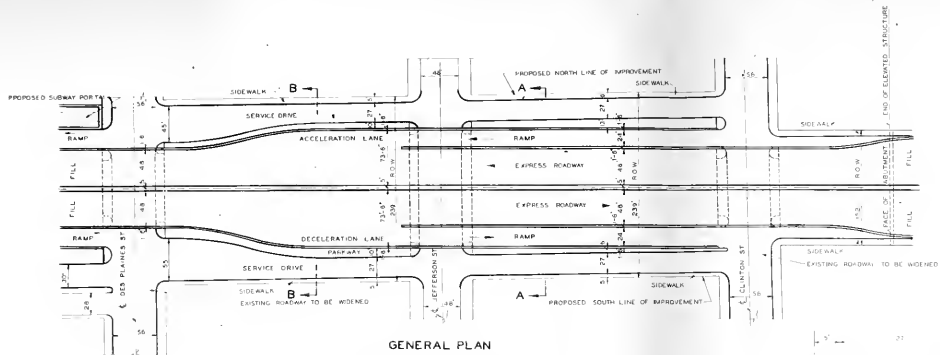


CITY OF CHICAGO
DEPARTMENT OF SUBWAYS AND TRACTION

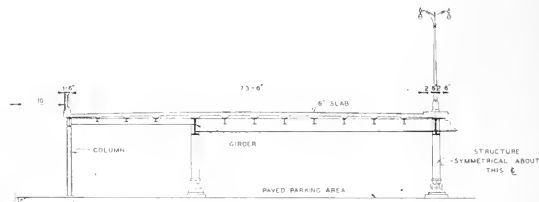
WIDENING AND IMPROVEMENT
OF CONGRESS STREET

STRUCTURE
DESPLAINES ST TO CANAL ST

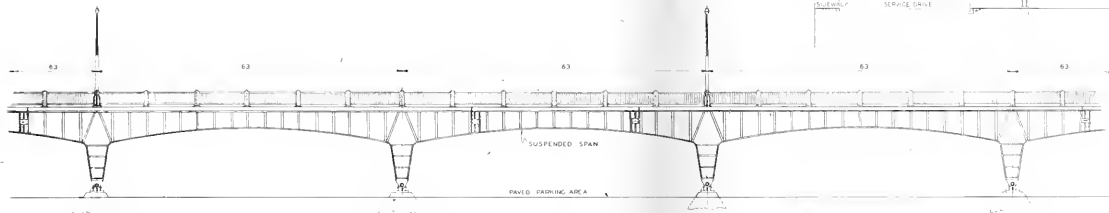
SEPTEMBER, 1939



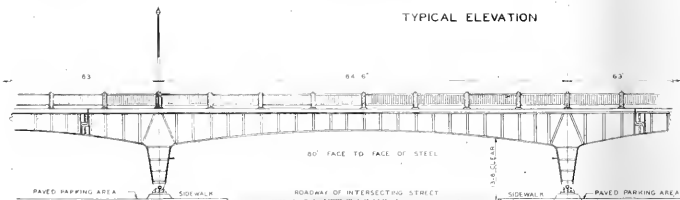
GENERAL PLAN



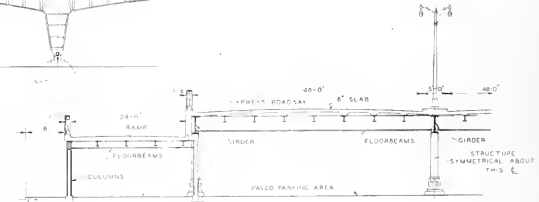
CROSS-SECTION B-B



TYPICAL ELEVATION



ELEVATION AT INTERSECTING STREETS



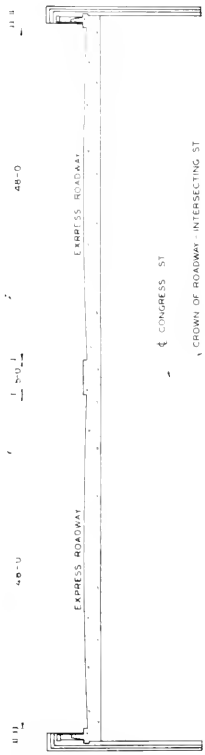
CROSS-SECTION A-A

CITY OF CHICAGO
DEPARTMENT OF SUBWAYS AND TRACTION

WIDENING AND IMPROVEMENT
OF CONGRESS STREET

STRUCTURE
DESPAINES ST TO CANAL ST.
SEPTEMBER, 1939



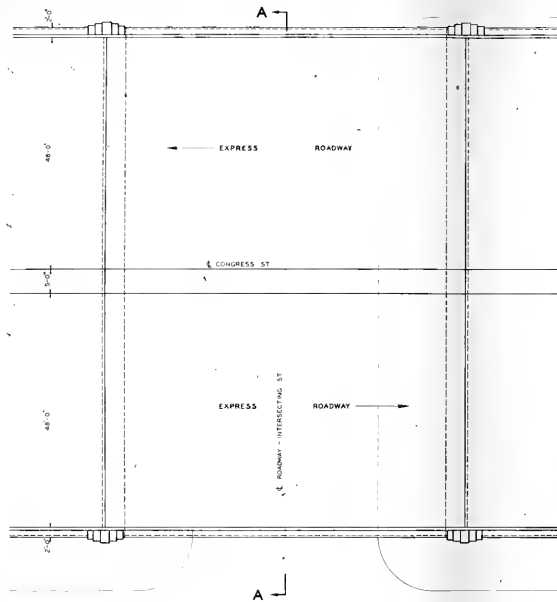


SECTION A-A

SCALE 0 2 4 6 FEET

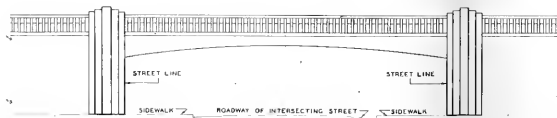


CITY OF CHICAGO
 DEPARTMENT OF SUBWAYS AND TRACTION
 WIDENING AND IMPROVEMENT
 OF CONGRESS STREET
 TYPICAL UNDERPASS THROUGH
 SOLID FILL SECTION
 SEPTEMBER, 1939



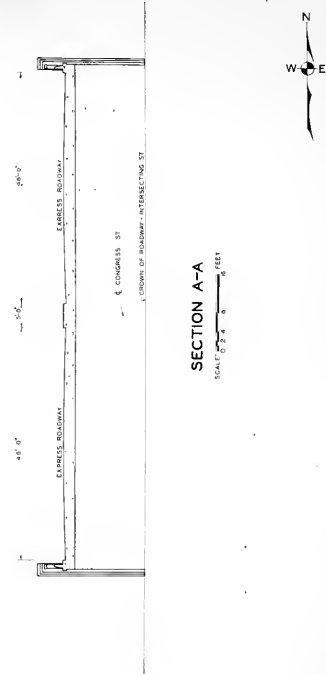
PLAN

SCALE 0 2 4 8 16 FEET



ELEVATION

SCALE 0 2 4 8 16 FEET

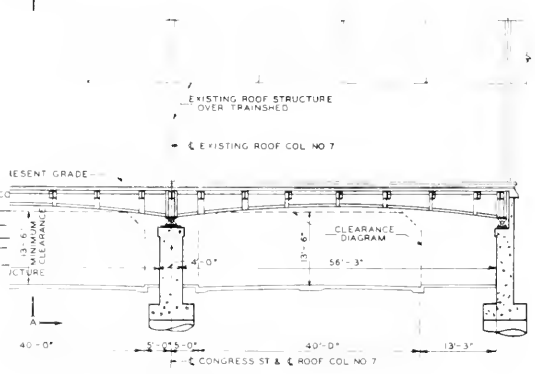
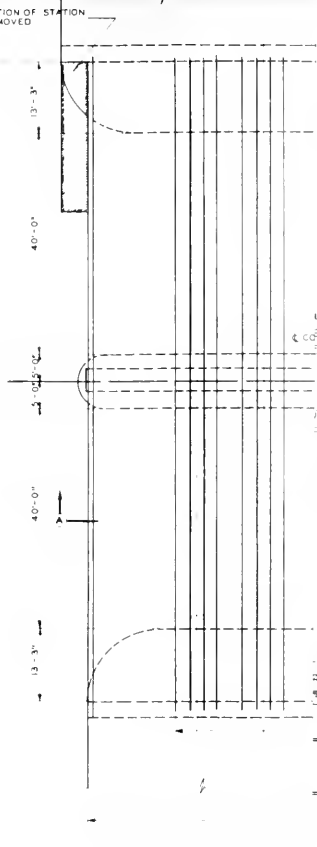


SECTION A-A
SCALE 0 2 4 8 16 FEET

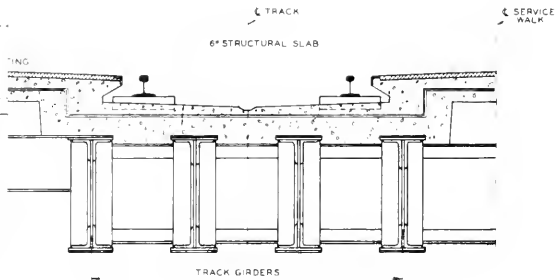
CITY OF CHICAGO
 DEPARTMENT OF SUBWAYS AND TRACTION
 WIDENING AND IMPROVEMENT
 OF CONGRESS STREET
 TYPICAL UNDERPASS THROUGH
 SOLID FILL SECTION
 SEPTEMBER, 1939

THIS PORTION OF STATION
TO BE REMOVED

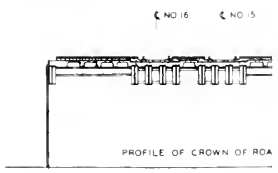
116'-6" FACE TO FACE ABUTMENTS



SECTION B-B
SCALE 0 5 10 20 FEET



SECTION C-C
SCALE 0 2 3 FEET

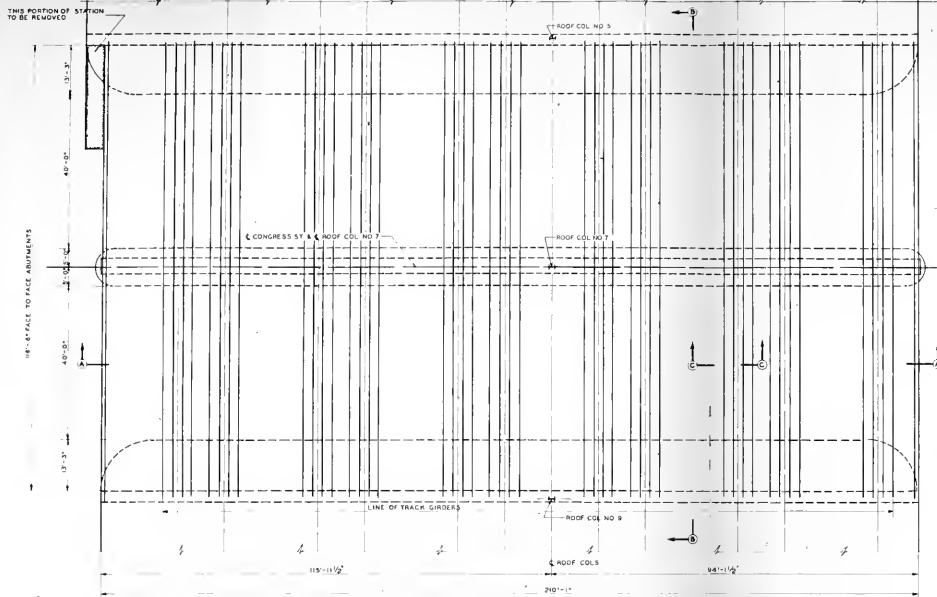


CITY OF CHICAGO
DEPARTMENT OF SUBWAYS AND TRACTION

WIDENING AND IMPROVEMENT
OF CONGRESS STREET

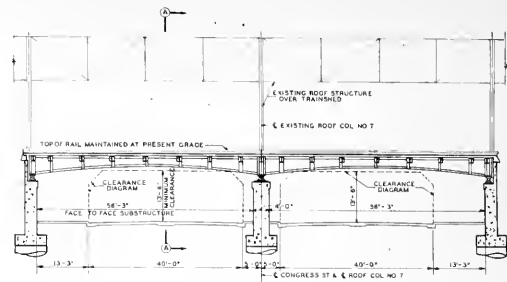
RECONSTRUCTION THROUGH LA SALLE ST.
RAILROAD STATION

SEPTEMBER, 1939



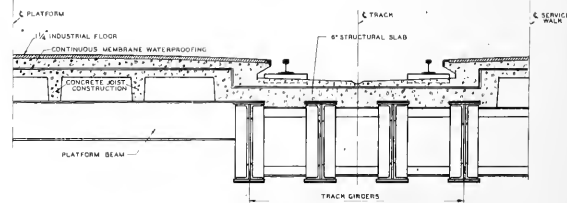
PLAN OF CONGRESS STREET THROUGH THE LA SALLE STREET STATION

SCALE 1" = 20' FEET



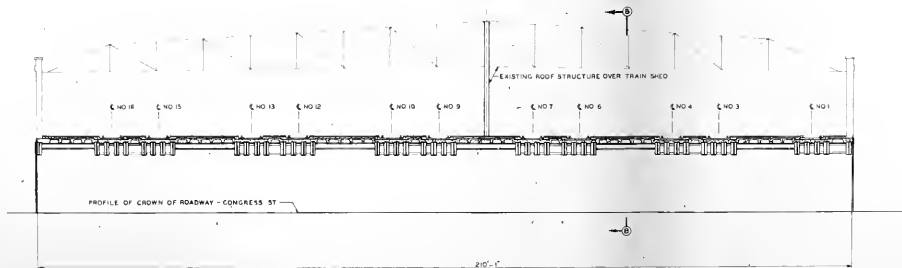
SECTION B-B

SCALE 1" = 20' FEET



SECTION C-C

SCALE 1" = 20' FEET



SECTION A-A THROUGH TRAIN SHED

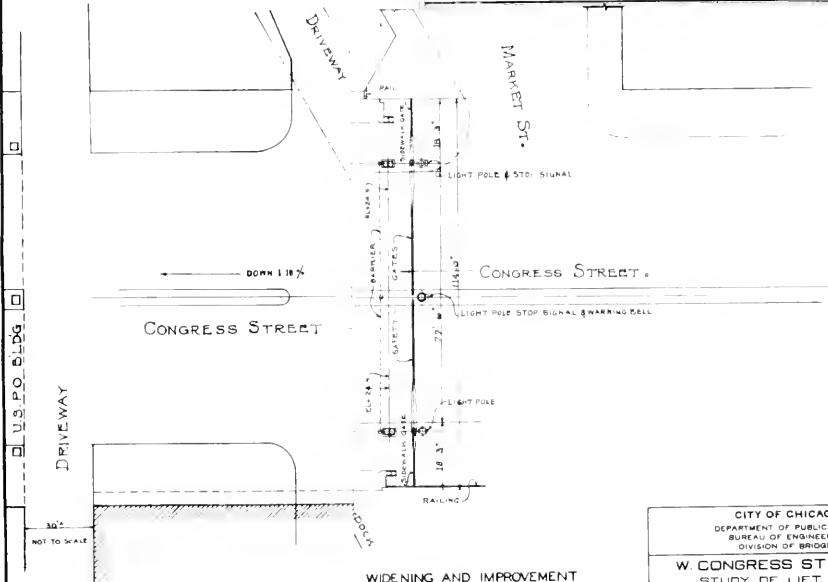
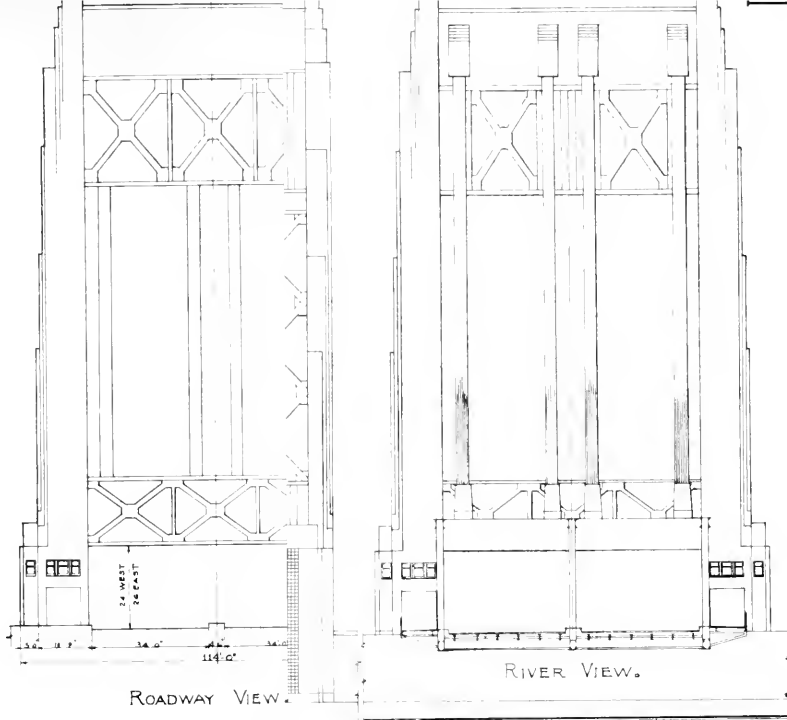
SCALE 1" = 20' FEET

CITY OF CHICAGO
DEPARTMENT OF SUBWAYS AND TRACTION

WIDENING AND IMPROVEMENT
OF CONGRESS STREET

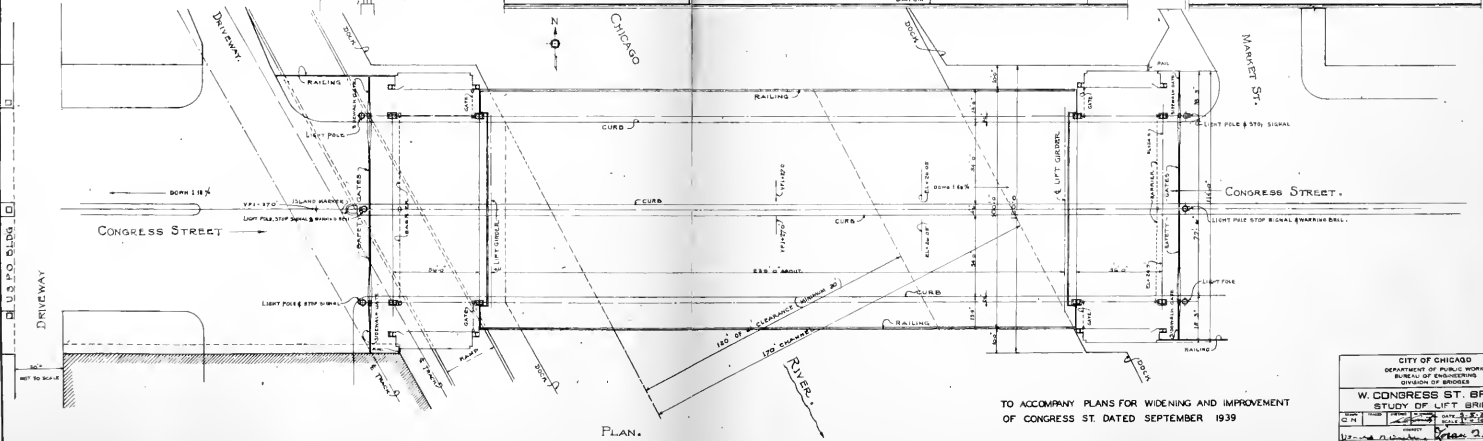
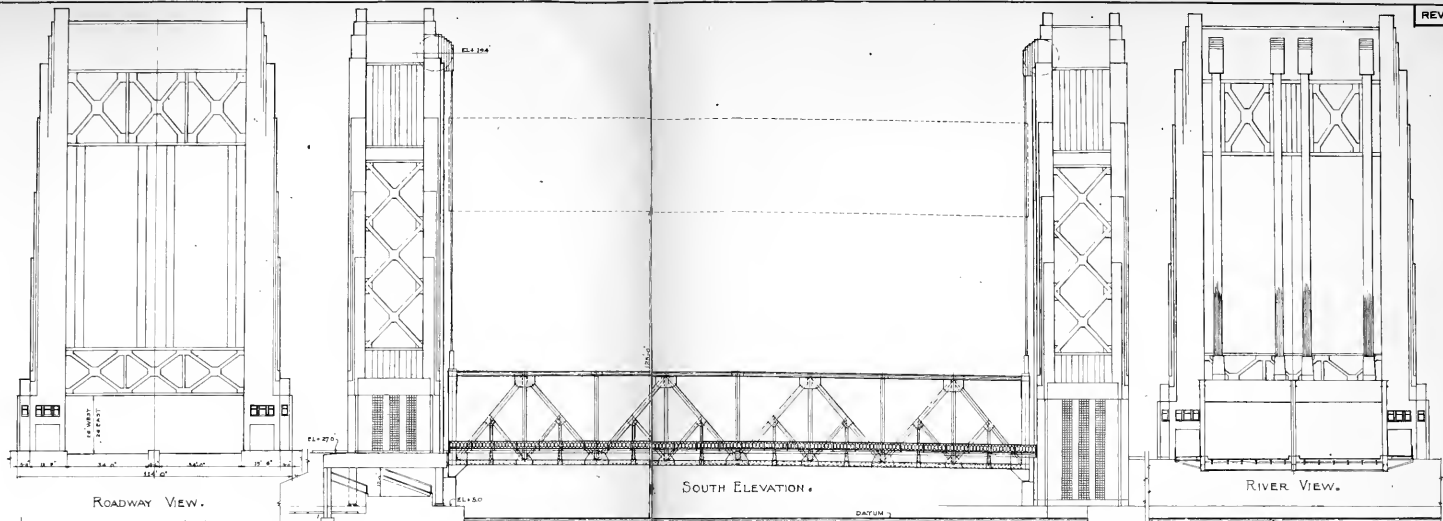
RECONSTRUCTION THROUGH LA SALLE ST.
RAILROAD STATION

SEPTEMBER, 1939



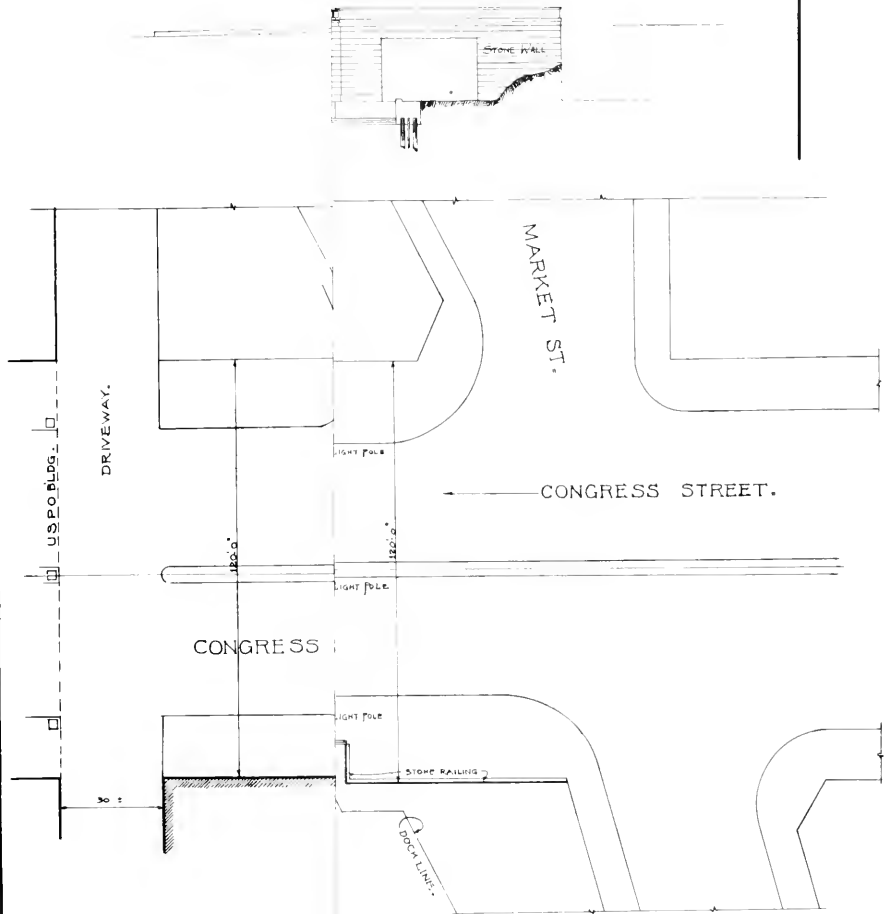
WIDENING AND IMPROVEMENT
SEPTEMBER 1939

CITY OF CHICAGO			
DEPARTMENT OF PUBLIC WORKS			
BUREAU OF ENGINEERING			
DIVISION OF BRIDGES			
W CONGRESS ST. BRIDGE			
STUDY OF LIFT BRIDGE			
DESIGNED	CHECKED	DATE	BY
CH	CH	8-5-39	W. J. ...
CONTRACT		APPROVED	
W. J. ...		[Signature]	
APPROVED		APPROVED	
[Signature]		[Signature]	
DRAWING NO 15618			



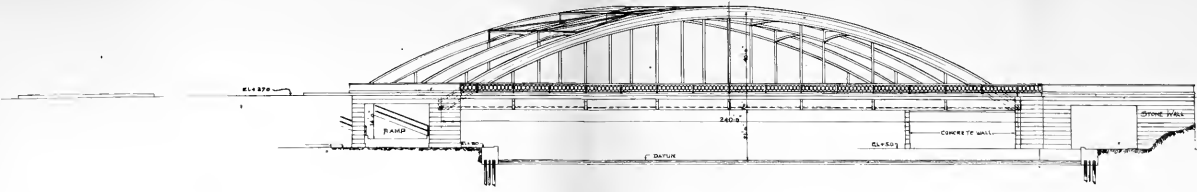
TO ACCOMPANY PLANS FOR WIDENING AND IMPROVEMENT
OF CONGRESS ST DATED SEPTEMBER 1939

CITY OF CHICAGO DEPARTMENT OF PUBLIC WORKS BUREAU OF ENGINEERING DIVISION OF BRIDGES	
W. CONGRESS ST. BRIDGE STUDY OF LIFT BRIDGE	
C.N.	W. H. ...
DATE	...
BY	...
DRW NO	15616

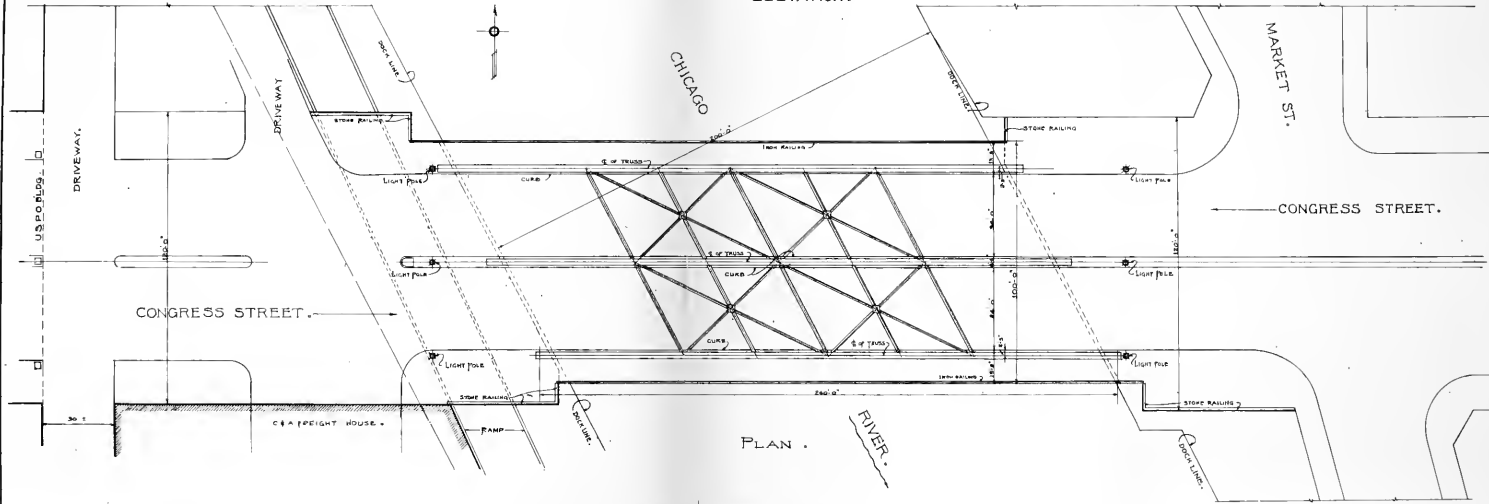


WIDENING AND IMPROVEMENT
SEPTEMBER 1939

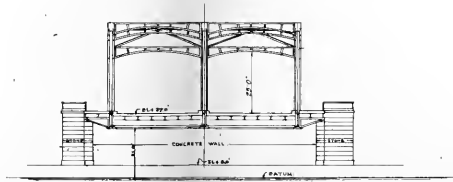
CITY OF CHICAGO			
DEPARTMENT OF PUBLIC WORKS			
BUREAU OF ENGINEERING			
DIVISION OF BRIDGES			
W. CONGRESS ST. BRIDGE			
STUDY OF FIXED BRIDGE			
DATE	BY	CHECKED	DATE
C.N.	<i>Edwards</i>	<i>Edwards</i>	8-23
DESIGNED BY	APPROVED BY	DATE	
<i>Edwards</i>	<i>Edwards</i>	8-23	
FOR THE YEAR OF 1939	FOR THE YEAR OF 1939	FOR THE YEAR OF 1939	FOR THE YEAR OF 1939
<i>Edwards</i>	<i>Edwards</i>	<i>Edwards</i>	<i>Edwards</i>
DRAWING NO. 15619			



ELEVATION.



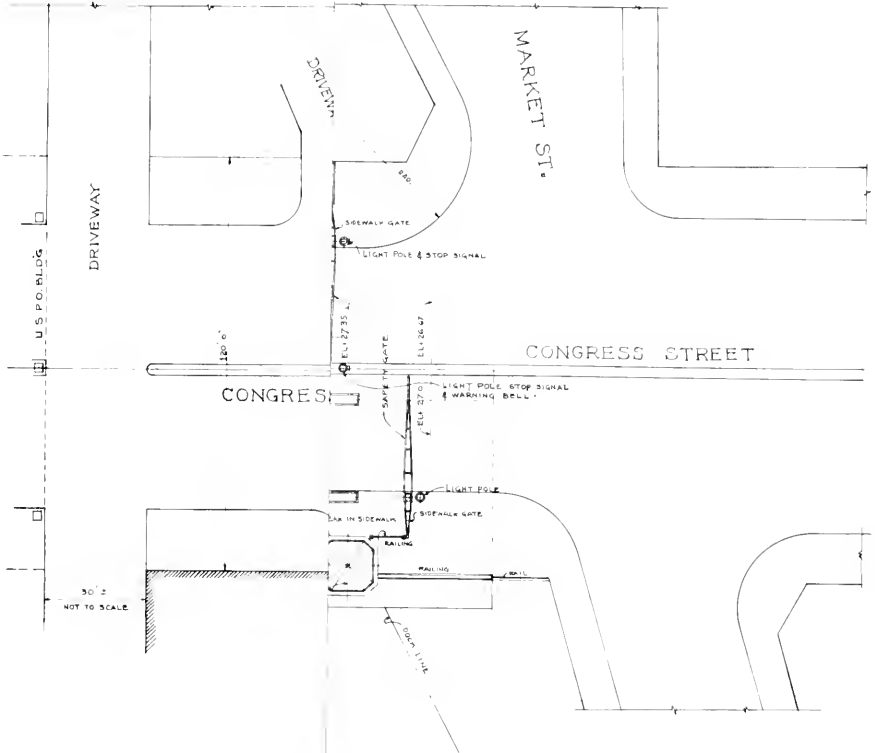
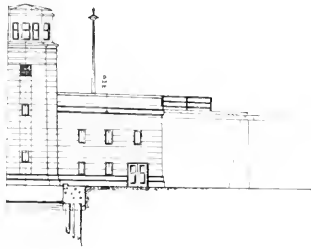
PLAN.



SECTION.

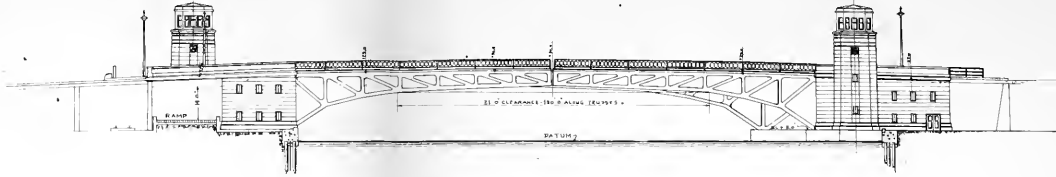
TO ACCOMPANY PLANS FOR WIDENING AND IMPROVEMENT
OF CONGRESS ST DATED SEPTEMBER 1939

CITY OF CHICAGO DEPARTMENT OF PUBLIC WORKS BUREAU OF ENGINEERING DIVISION OF BRIDGES	
W. CONGRESS ST. BRIDGE STUDY OF FIXED BRIDGE	
C.N.	DATE
DESIGNED BY	HECKER
CHECKED BY	W. H. BENTLEY
APPROVED BY	W. H. BENTLEY
DRWG NO 15619	

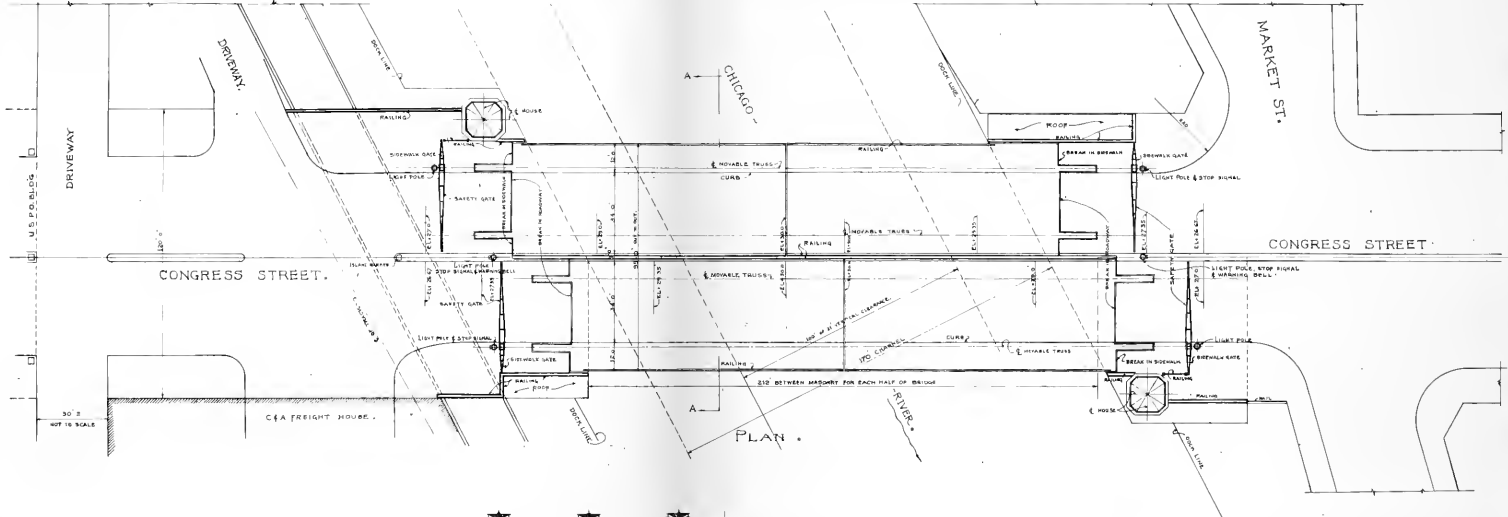


WIDENING AND IMPROVEMENT
SEPTEMBER 1939

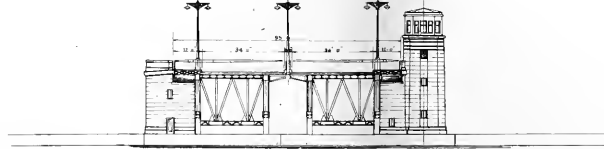
CITY OF CHICAGO			
DEPARTMENT OF PUBLIC WORKS			
BUREAU OF ENGINEERING			
DIVISION OF BRIDGES			
W. CONGRESS ST BRIDGE			
STUDY OF BASCULE BRIDGE			
DATE	DESIGNED BY	DATE	12-22-39
C.N.	<i>[Signature]</i>	DATE	1-13-40
BY	<i>[Signature]</i>	DATE	<i>[Signature]</i>
BY	<i>[Signature]</i>	DATE	<i>[Signature]</i>
BY	<i>[Signature]</i>	DATE	<i>[Signature]</i>
DRAWN BY		15617	



ELEVATION



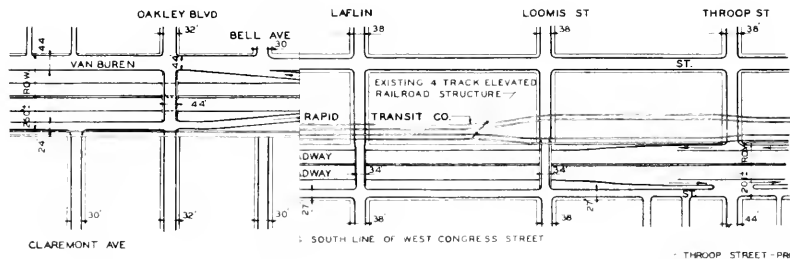
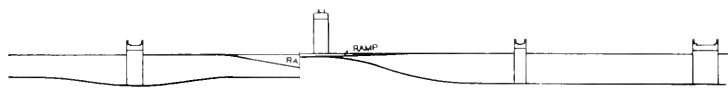
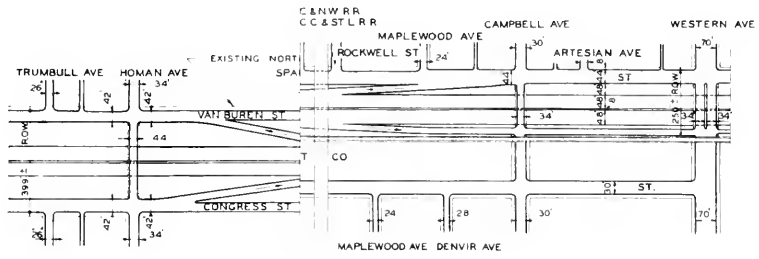
PLAN



SECTION A. A.

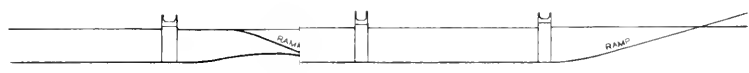
TO ACCOMPANY PLANS FOR WIDENING AND IMPROVEMENT
OF CONGRESS ST. DATED SEPTEMBER 1939

CITY OF CHICAGO	
DEPARTMENT OF PUBLIC WORKS	
BUREAU OF ENGINEERING	
DIVISION OF BRIDGES	
W CONGRESS ST. BRIDGE	
STUDY OF BASCOSULE BRIDGE	
CR. NO.	113-39
DATE	SEP 13 1939
DESIGNED BY	W. M. RAYBURN
CHECKED BY	W. M. RAYBURN
APPROVED BY	W. M. RAYBURN
DRWG NO.	15617



PROPOSED SOUTH LINE OF IMPROVEMENT

THROOP STREET - PROPOSED WIDENING TO HARRISON ST

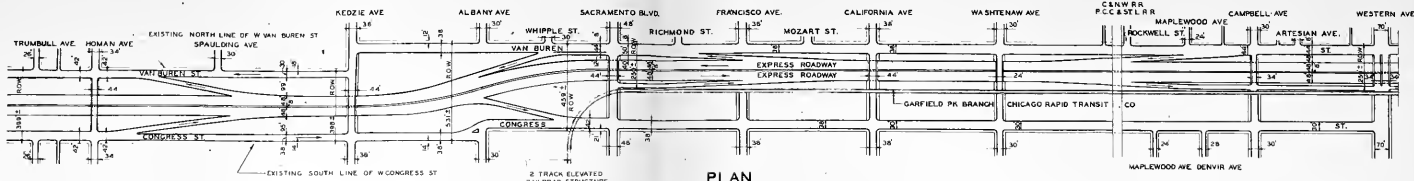


CITY OF CHICAGO
DEPARTMENT OF SUBWAYS AND TRACTION

A SUGGESTION FOR THE DEVELOPMENT
OF A WEST SIDE SUPERHIGHWAY

PLAN AND PROFILE
ST. LOUIS AVE. TO THROOP ST.

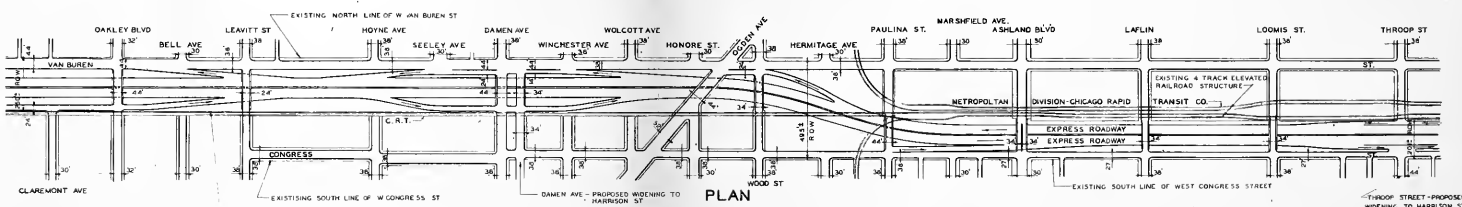
SEPTEMBER, 1939



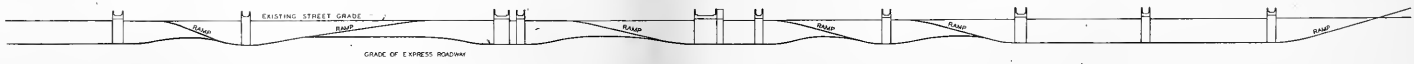
PLAN



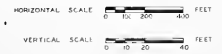
PROFILE



PLAN



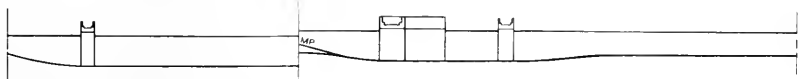
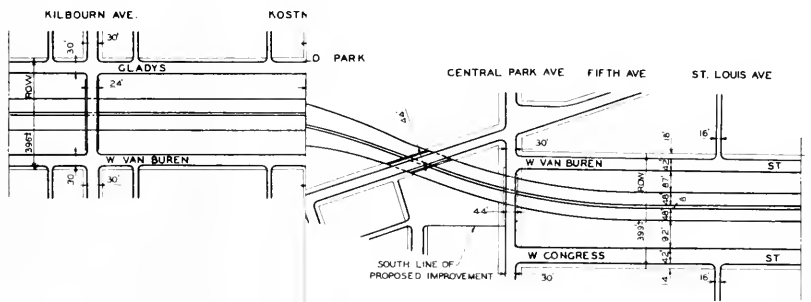
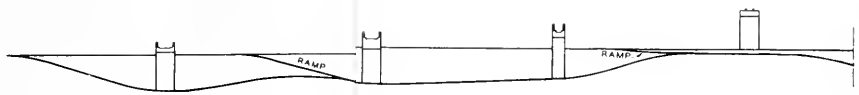
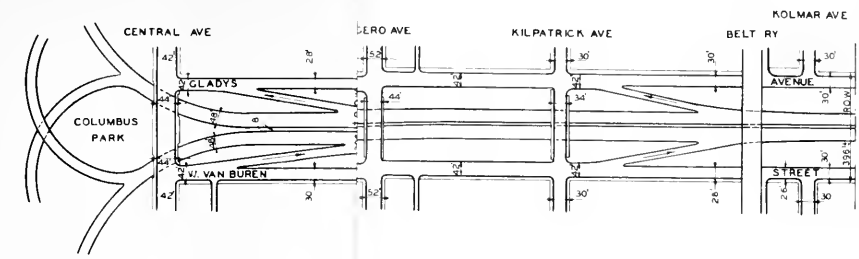
PROFILE



CITY OF CHICAGO
 DEPARTMENT OF SUBWAYS AND TRACTION
 A SUGGESTION FOR THE DEVELOPMENT
 OF A WEST SIDE SUPERHIGHWAY

PLAN AND PROFILE
 ST. LOUIS AVE. TO THROOP ST.

SEPTEMBER, 1939

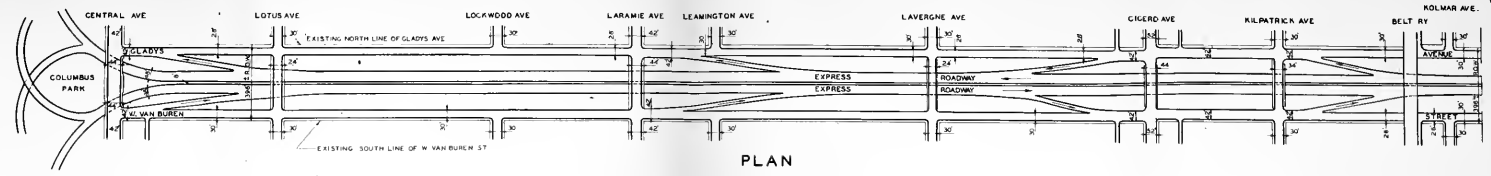


CITY OF CHICAGO
DEPARTMENT OF SUBWAYS AND TRACTION

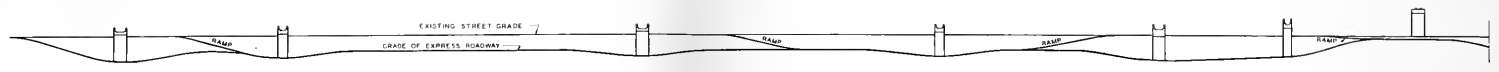
A SUGGESTION FOR THE DEVELOPMENT
OF A WEST SIDE SUPERHIGHWAY

PLAN AND PROFILE
COLUMBUS PARK TO ST. LOUIS AVE.

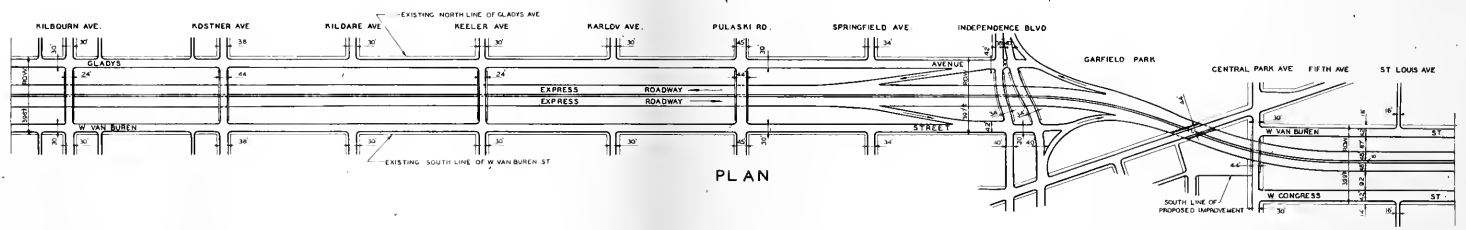
SEPTEMBER, 1939



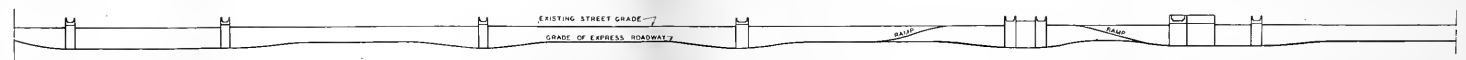
PLAN



PROFILE



PLAN



PROFILE

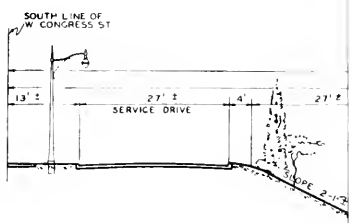


CITY OF CHICAGO
 DEPARTMENT OF SUBWAYS AND TRACTION

A SUGGESTION FOR THE DEVELOPMENT
 OF A WEST SIDE SUPERHIGHWAY

PLAN AND PROFILE
 COLUMBUS PARK TO ST. LOUIS AVE.

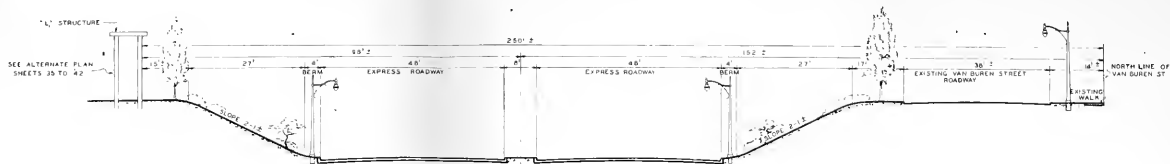
SEPTEMBER, 1939



CITY OF CHICAGO
 DEPARTMENT OF SUBWAYS AND TRACTION

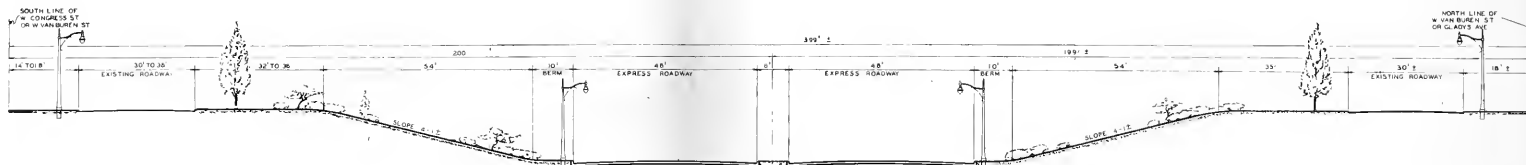
A SUGGESTION FOR THE DEVELOPMENT
 OF A WEST SIDE SUPERHIGHWAY

TYPICAL CROSS SECTIONS
 SEPTEMBER, 1939



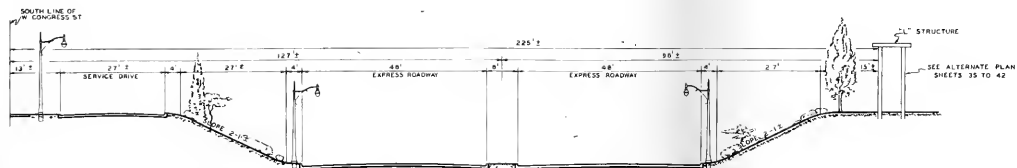
TYPICAL CROSS SECTION
SACRAMENTO BLVD TO HONORE ST

SCALE 0 5 10 20 FEET



TYPICAL CROSS SECTION
CENTRAL AVE TO KEDZIE AVE

SCALE 0 5 10 20 FEET

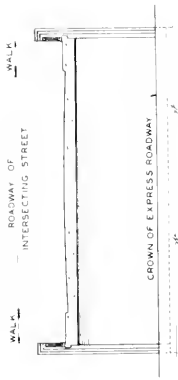
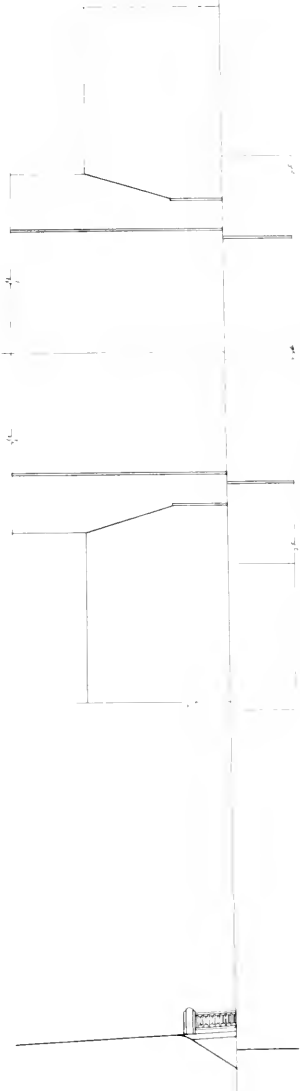


TYPICAL CROSS SECTION
MARSHFIELD AVE TO LOOMIS ST.

SCALE 0 5 10 20 FEET

CITY OF CHICAGO
DEPARTMENT OF SUBWAYS AND TRACTION
A SUGGESTION FOR THE DEVELOPMENT
OF A WEST SIDE SUPERHIGHWAY

TYPICAL CROSS SECTIONS
SEPTEMBER, 1939



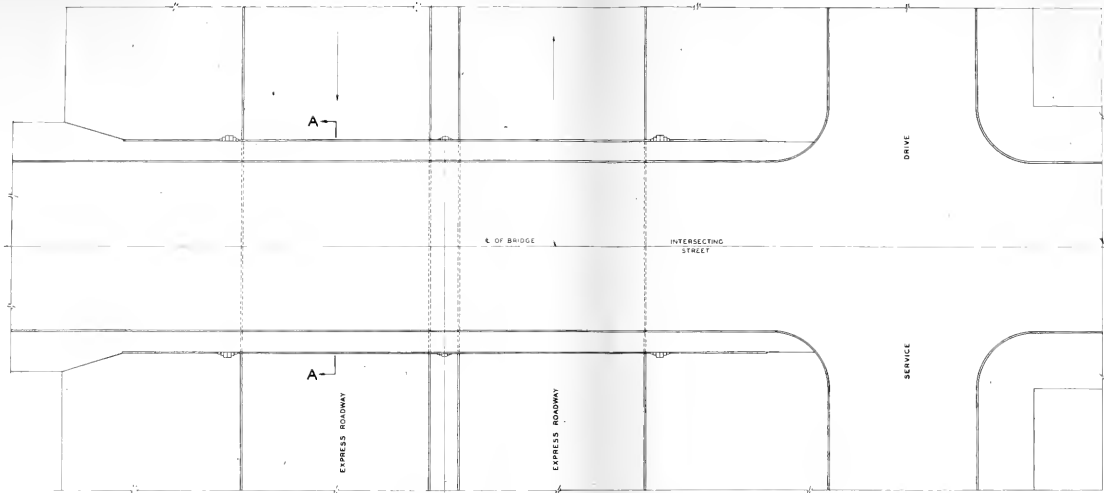
SECTION A-A
 SCALE 0 2 5 10 20 FEET

CITY OF CHICAGO
 DEPARTMENT OF SUBWAYS AND TRACTION

A SUGGESTION FOR THE DEVELOPMENT
 OF A WEST SIDE SUPERHIGHWAY

TYPICAL OVERPASS STRUCTURE

SEPTEMBER, 1939

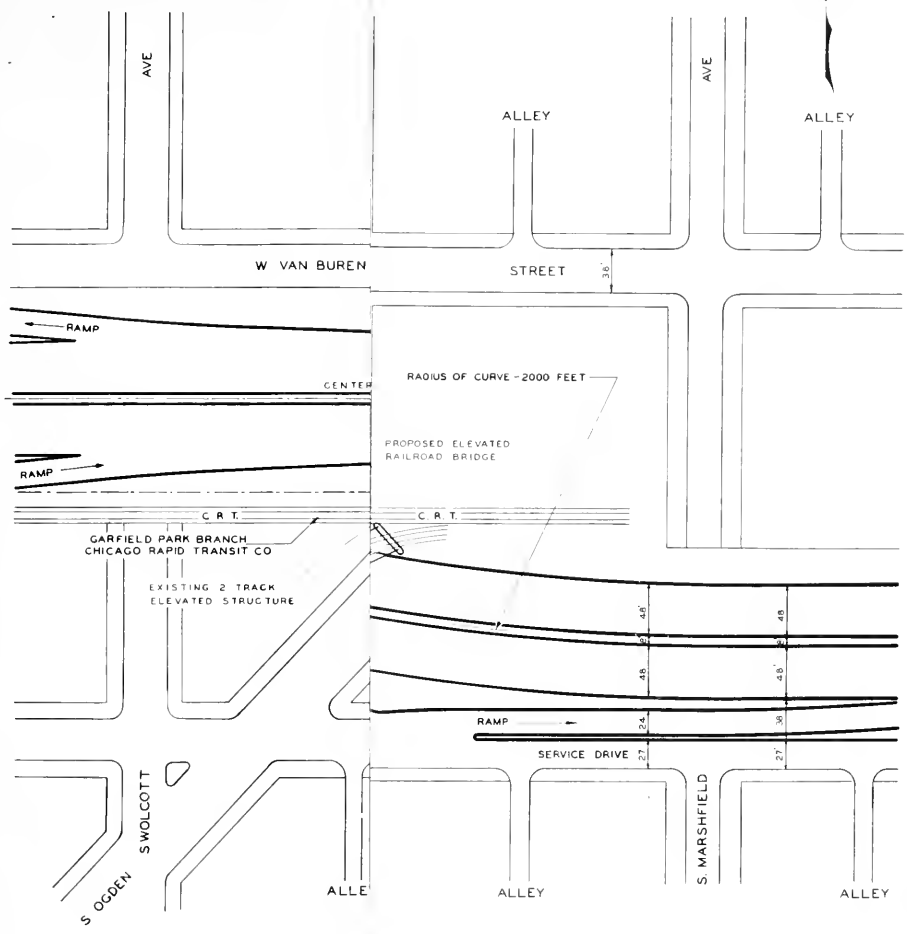


PLAN
SCALE 0.2 5 10 20 FEET



ELEVATION
SCALE 0.2 5 10 20 FEET

CITY OF CHICAGO
DEPARTMENT OF SUBWAYS AND TRACTION
A SUGGESTION FOR THE DEVELOPMENT
OF A WEST SIDE SUPERHIGHWAY
TYPICAL OVERPASS STRUCTURE
SEPTEMBER, 1939

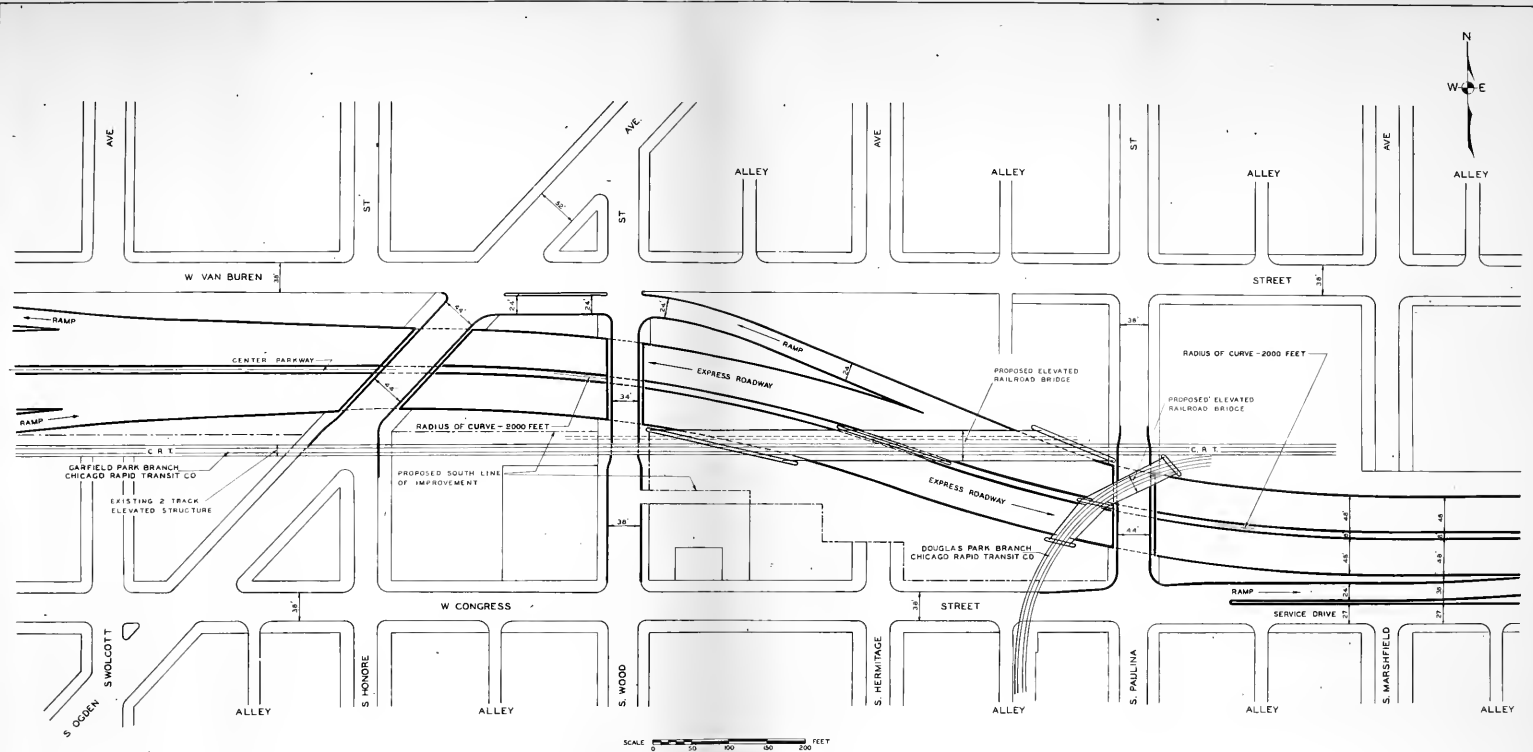


CITY OF CHICAGO
DEPARTMENT OF SUBWAYS AND TRACTION

A SUGGESTION FOR THE DEVELOPMENT
OF A WEST SIDE SUPERHIGHWAY

DETAIL - WOLCOTT AVE. TO MARSHFIELD AVE

SEPTEMBER, 1939

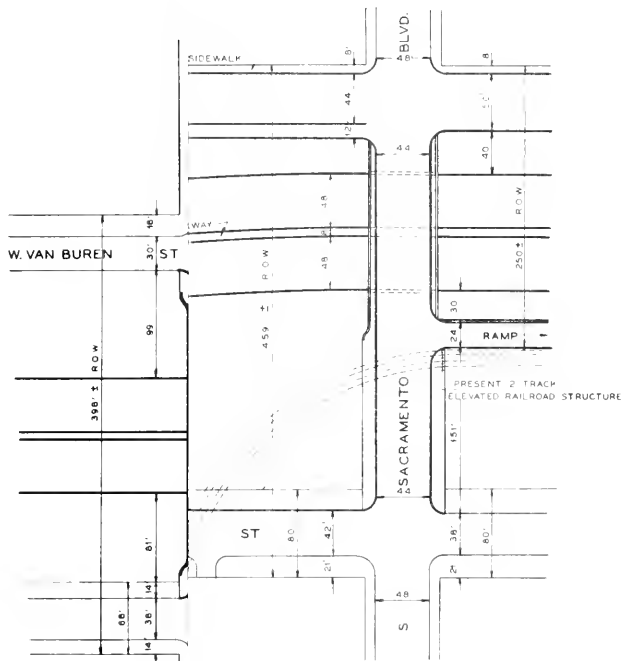


CITY OF CHICAGO
 DEPARTMENT OF SUBWAYS AND TRACTION

A SUGGESTION FOR THE DEVELOPMENT
 OF A WEST SIDE SUPERHIGHWAY

DETAIL - WOLCOTT AVE. TO MARSHFIELD AVE

SEPTEMBER, 1939

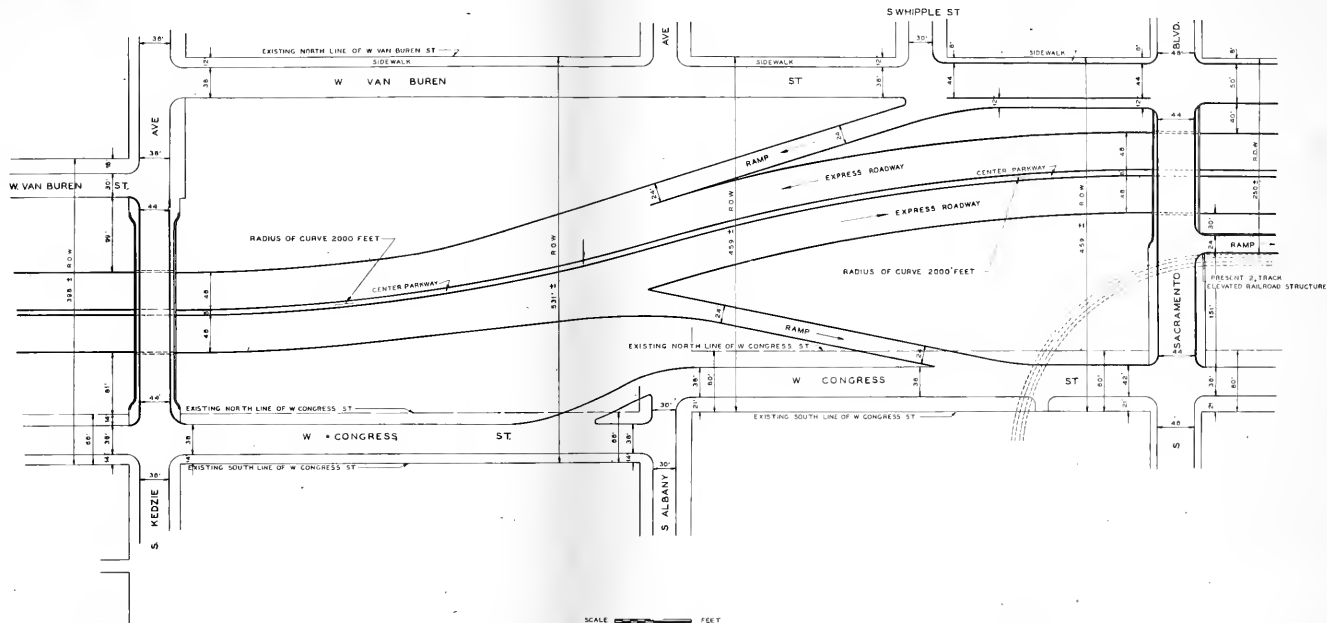


CITY OF CHICAGO
DEPARTMENT OF SUBWAYS AND TRACTION

A SUGGESTION FOR THE DEVELOPMENT
OF A WEST SIDE SUPERHIGHWAY

DETAIL - KEDZIE AVE TO
SACRAMENTO BLVD.

SEPTEMBER, 1939

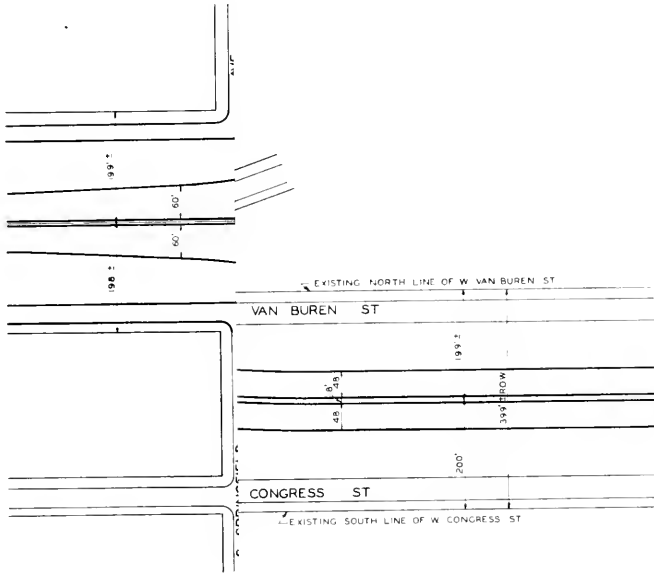


CITY OF CHICAGO
DEPARTMENT OF SUBWAYS AND TRACTION

A SUGGESTION FOR THE DEVELOPMENT
OF A WEST SIDE SUPERHIGHWAY

DETAIL - KEDZIE AVE TO
SACRAMENTO BLVD.

SEPTEMBER, 1939

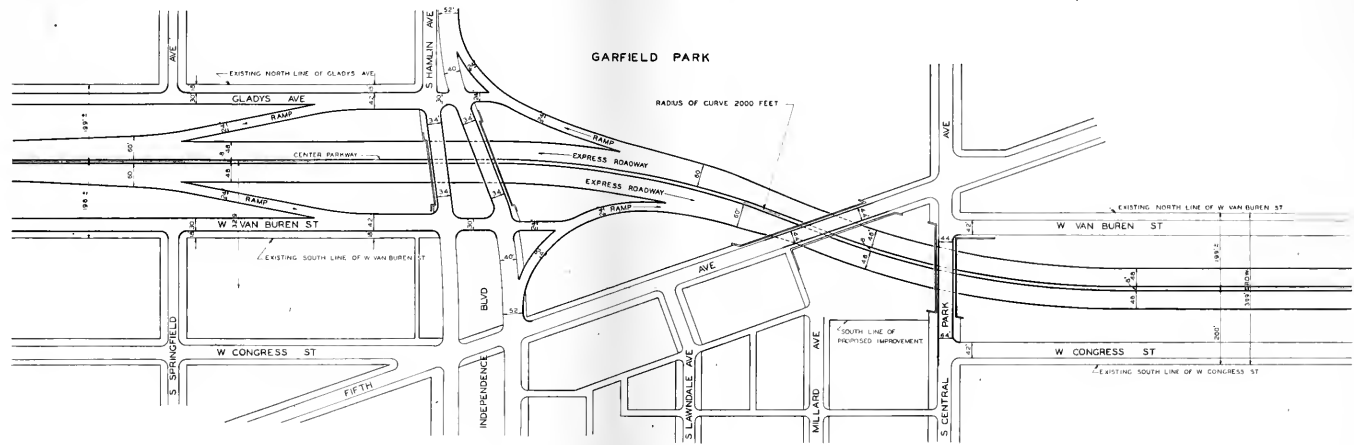


CITY OF CHICAGO
DEPARTMENT OF SUBWAYS AND TRACTION

A SUGGESTION FOR THE DEVELOPMENT
OF A WEST SIDE SUPERHIGHWAY

DETAIL AT GARFIELD PARK

SEPTEMBER, 1939



GARFIELD PARK

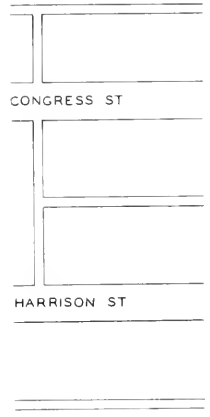
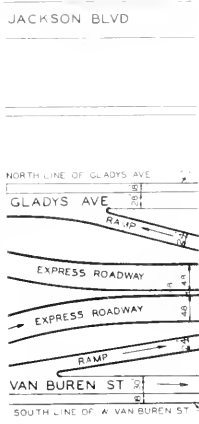
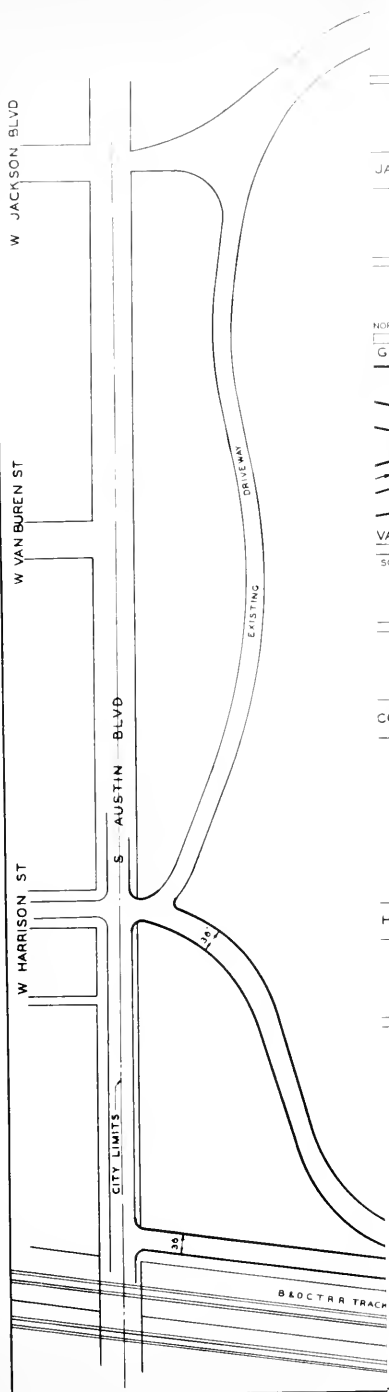


CITY OF CHICAGO
DEPARTMENT OF SUBWAYS AND TRACTION

A SUGGESTION FOR THE DEVELOPMENT
OF A WEST SIDE SUPERHIGHWAY

DETAIL AT GARFIELD PARK

SEPTEMBER, 1939

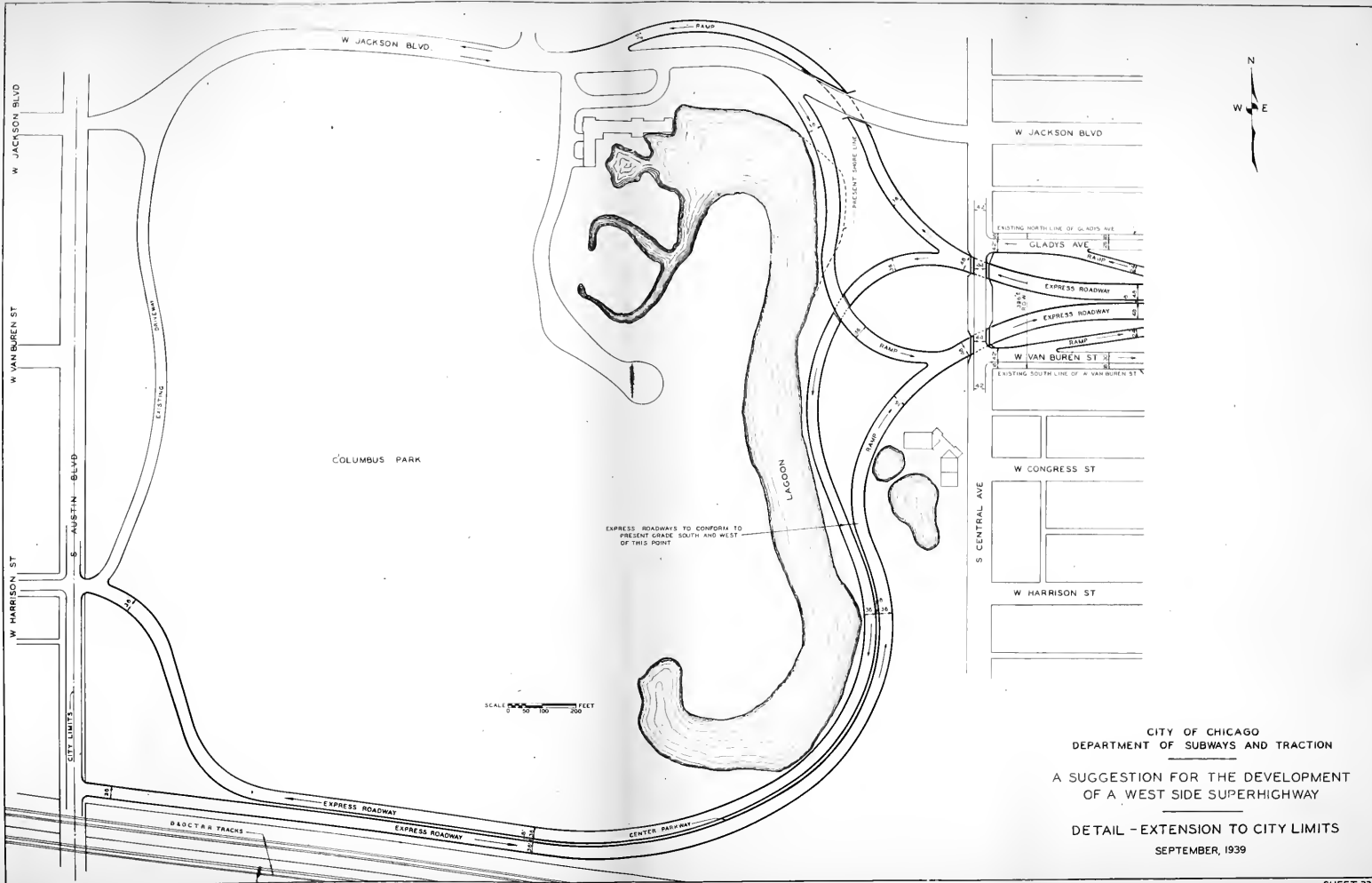


CITY OF CHICAGO
DEPARTMENT OF SUBWAYS AND TRACTION

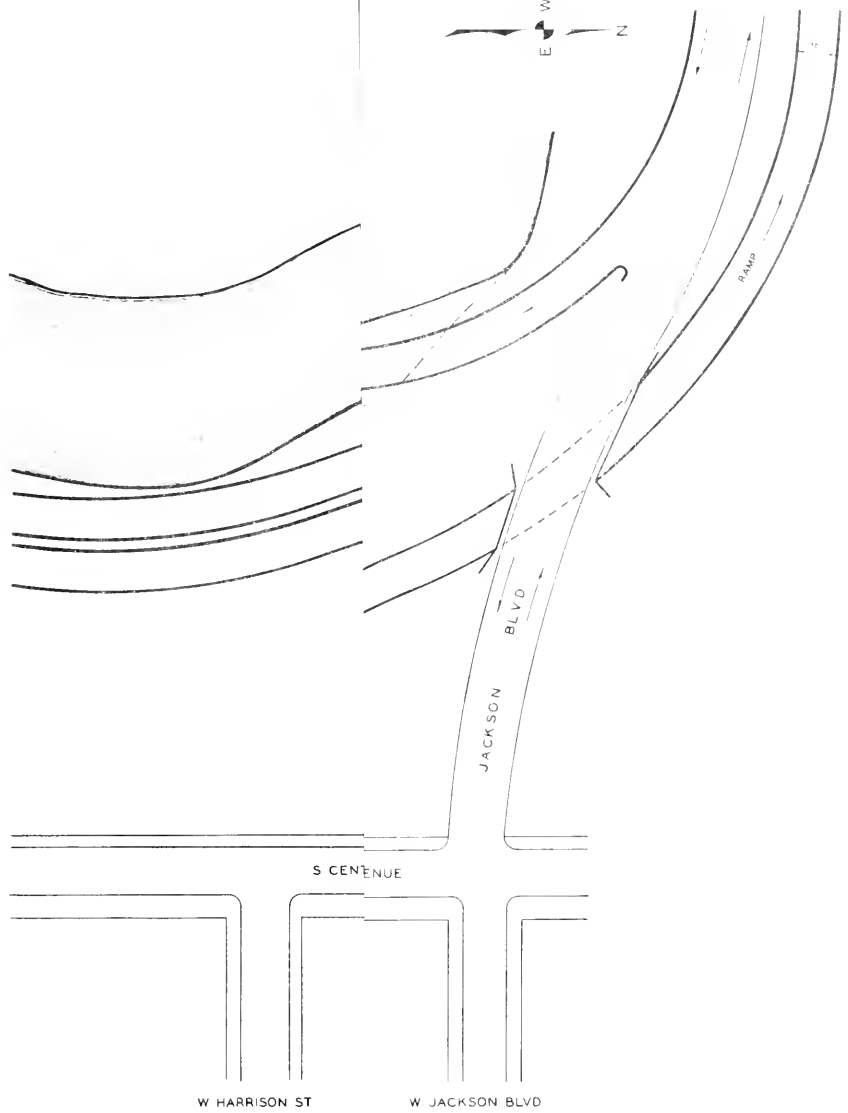
A SUGGESTION FOR THE DEVELOPMENT
OF A WEST SIDE SUPERHIGHWAY

DETAIL - EXTENSION TO CITY LIMITS

SEPTEMBER, 1939



CITY OF CHICAGO
 DEPARTMENT OF SUBWAYS AND TRACTION
 A SUGGESTION FOR THE DEVELOPMENT
 OF A WEST SIDE SUPERHIGHWAY
 DETAIL - EXTENSION TO CITY LIMITS
 SEPTEMBER, 1939

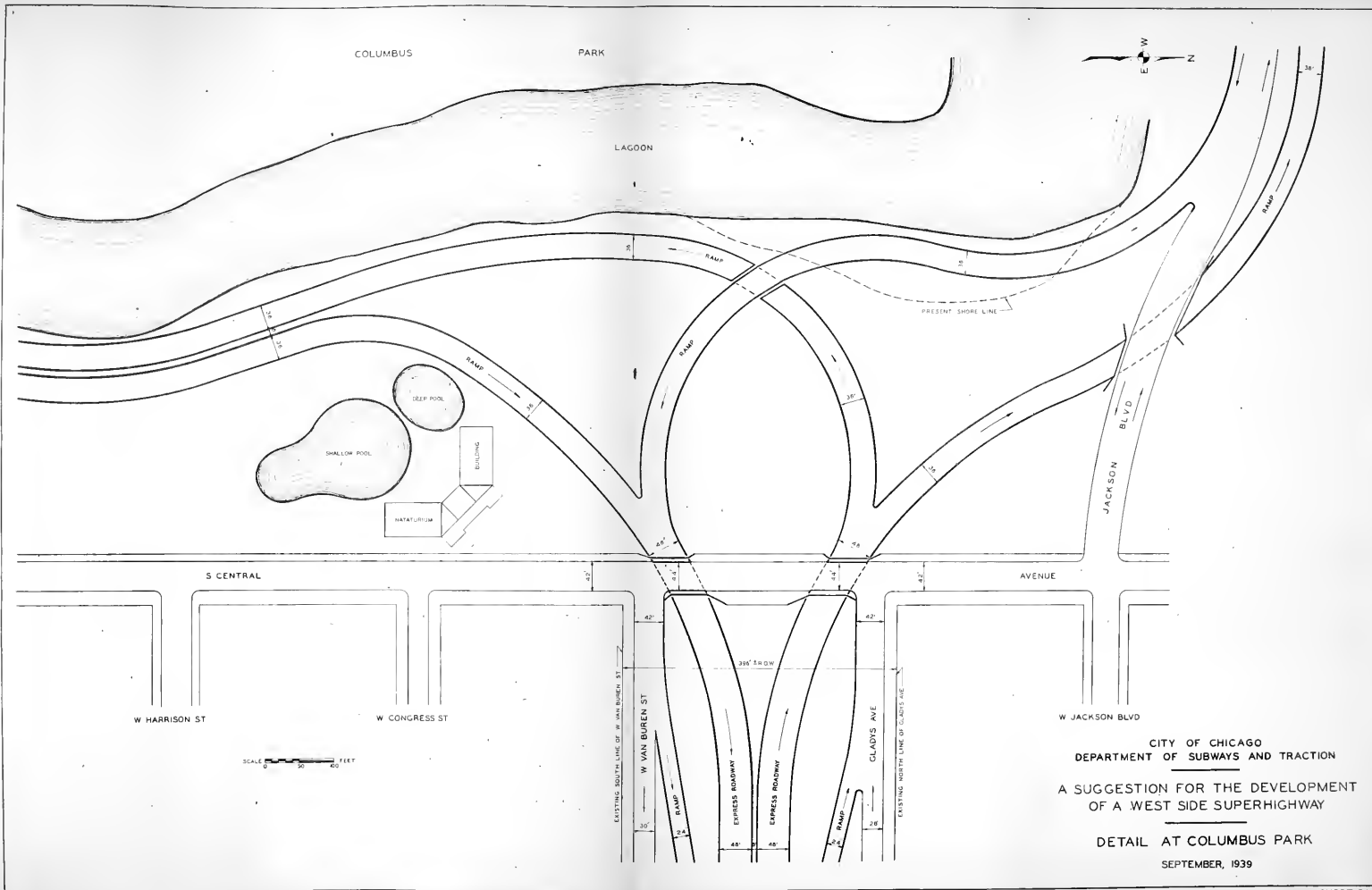


CITY OF CHICAGO
 DEPARTMENT OF SUBWAYS AND TRACTION

A SUGGESTION FOR THE DEVELOPMENT
 OF A WEST SIDE SUPERHIGHWAY

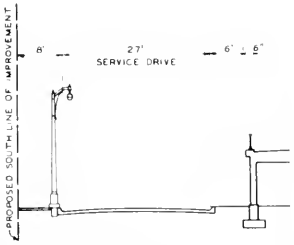
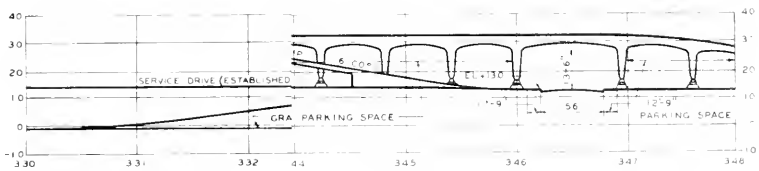
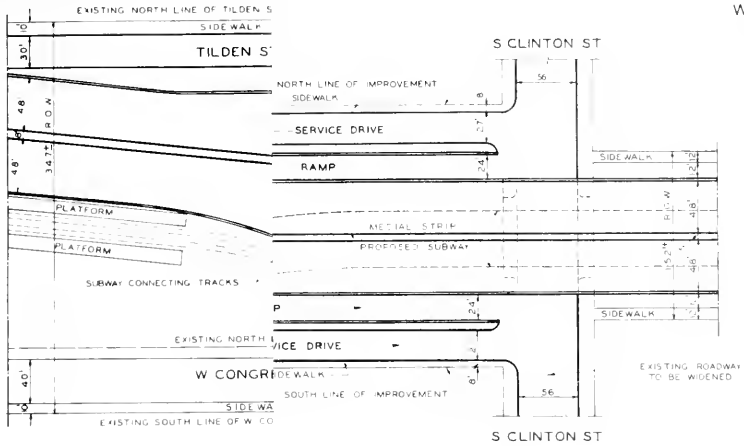
DETAIL AT COLUMBUS PARK

SEPTEMBER, 1939



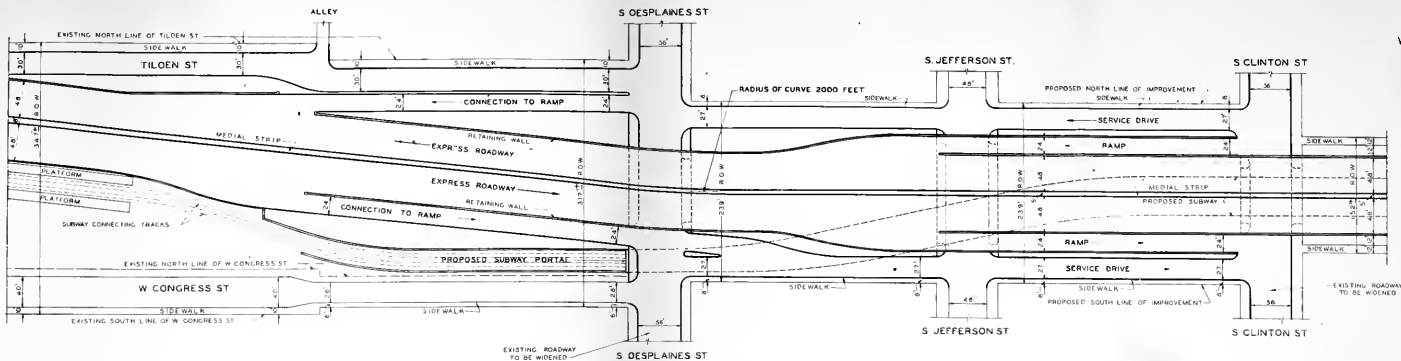
CITY OF CHICAGO
 DEPARTMENT OF SUBWAYS AND TRACTION
 A SUGGESTION FOR THE DEVELOPMENT
 OF A WEST SIDE SUPERHIGHWAY
 DETAIL AT COLUMBUS PARK
 SEPTEMBER, 1939



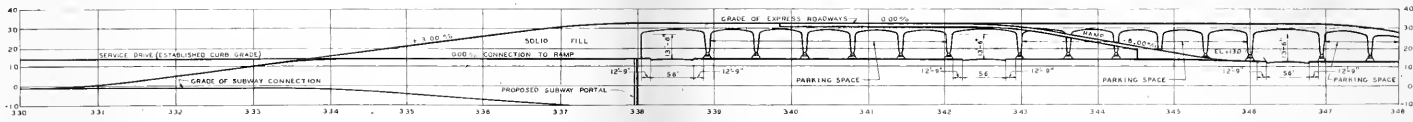


CITY OF CHICAGO
 DEPARTMENT OF SUBWAYS AND TRACTION
 WIDENING AND IMPROVEMENT
 OF CONGRESS STREET
 ALTERNATE PLAN
 PLAN AND PROFILE
 HALSTED ST TO CLINTON ST.
 SEPTEMBER, 1939

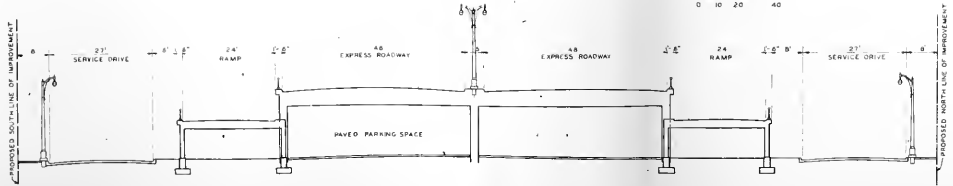




PLAN
SCALE 0 50 100 FEET

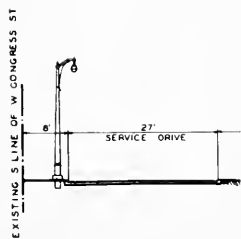
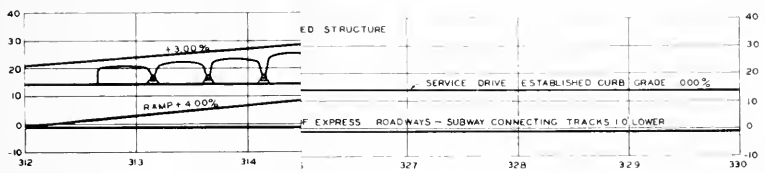
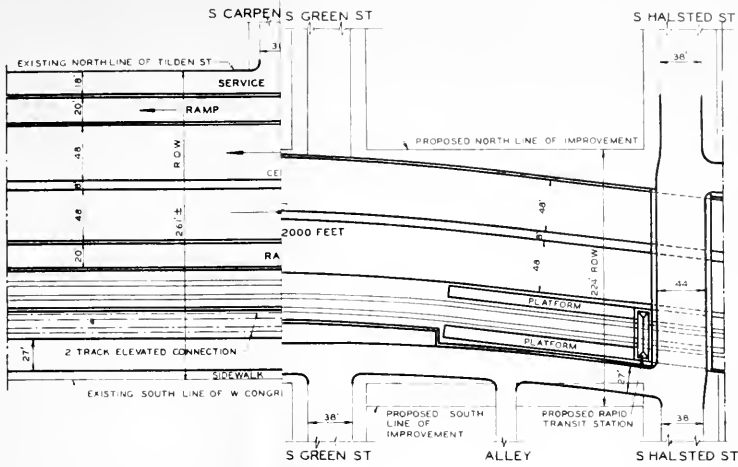


PROFILE
HORIZONTAL SCALE 0 50 100 FEET
VERTICAL SCALE 0 10 20 40 FEET



CROSS SECTION
AT STATION 344+00
SCALE 0 10 20 FEET

CITY OF CHICAGO
DEPARTMENT OF SUBWAYS AND TRACTION
WIDENING AND IMPROVEMENT
OF CONGRESS STREET
ALTERNATE PLAN
PLAN AND PROFILE
HALSTED ST. TO CLINTON ST.
SEPTEMBER, 1939

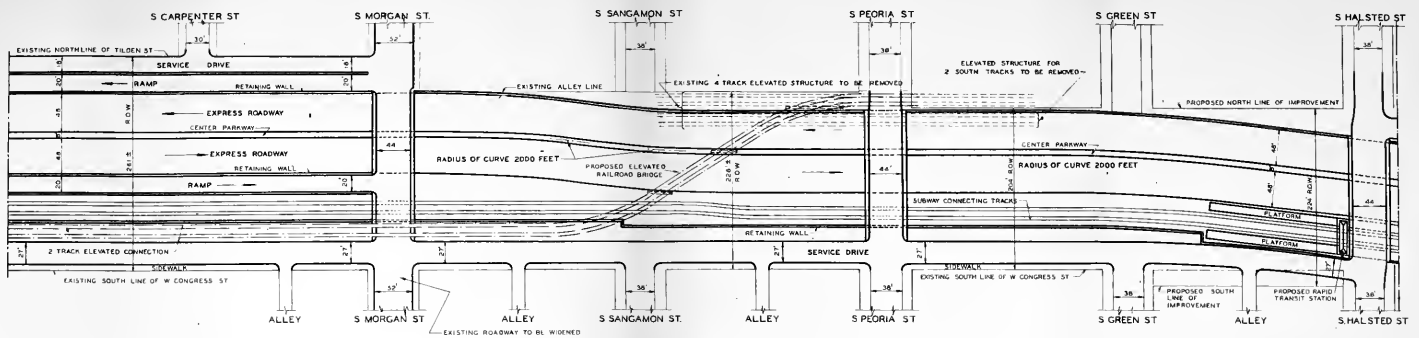


CITY OF CHICAGO
 DEPARTMENT OF SUBWAYS AND TRACTION
 WIDENING AND IMPROVEMENT
 OF CONGRESS STREET

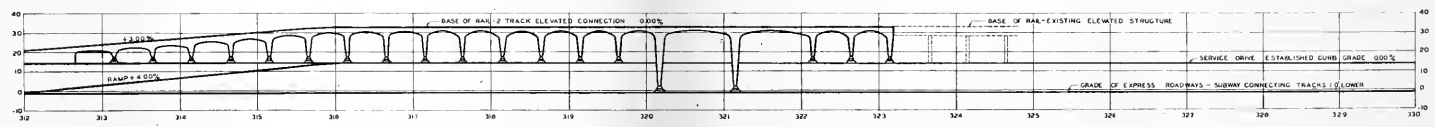
ALTERNATE PLAN

PLAN AND PROFILE
 ABERDEEN ST. TO HALSTED ST.

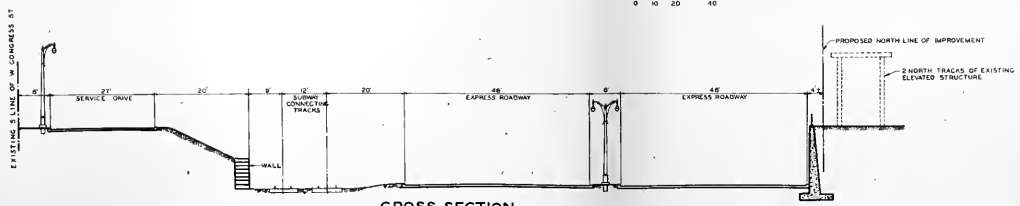
SEPTEMBER, 1939



PLAN
SCALE 1" = 20' FEET

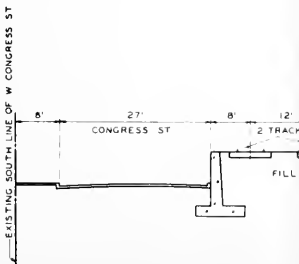
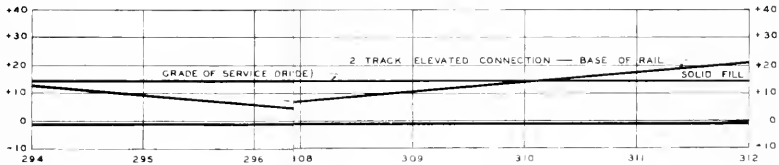
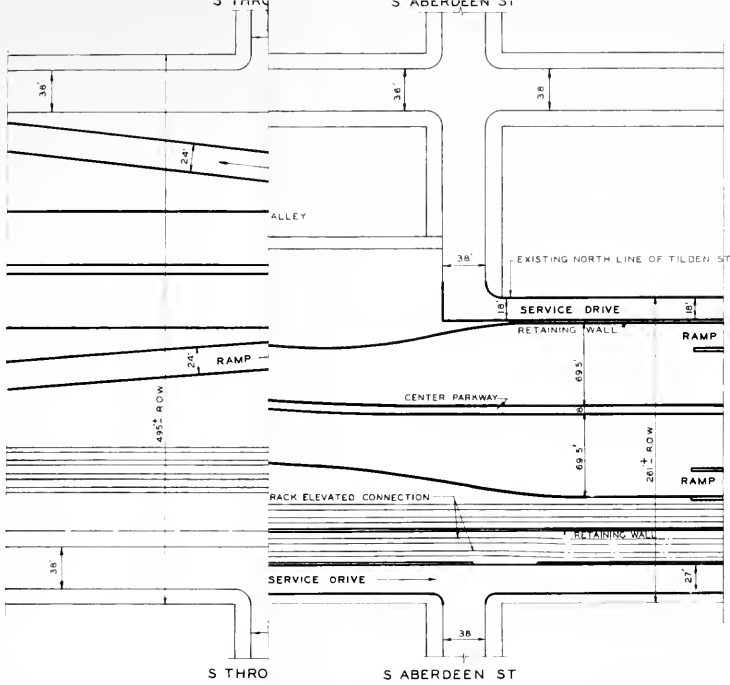


PROFILE
HORIZONTAL SCALE 1" = 20' FEET
VERTICAL SCALE 1" = 10' FEET



CROSS SECTION
AT STATION 326+00
SCALE 1" = 20' FEET

CITY OF CHICAGO
DEPARTMENT OF SUBWAYS AND TRACTION
WIDENING AND IMPROVEMENT
OF CONGRESS ST
ALTERNATE PLAN
PLAN AND PROFILE
ABERDEEN ST. TO HALSTED ST.
SEPTEMBER, 1939

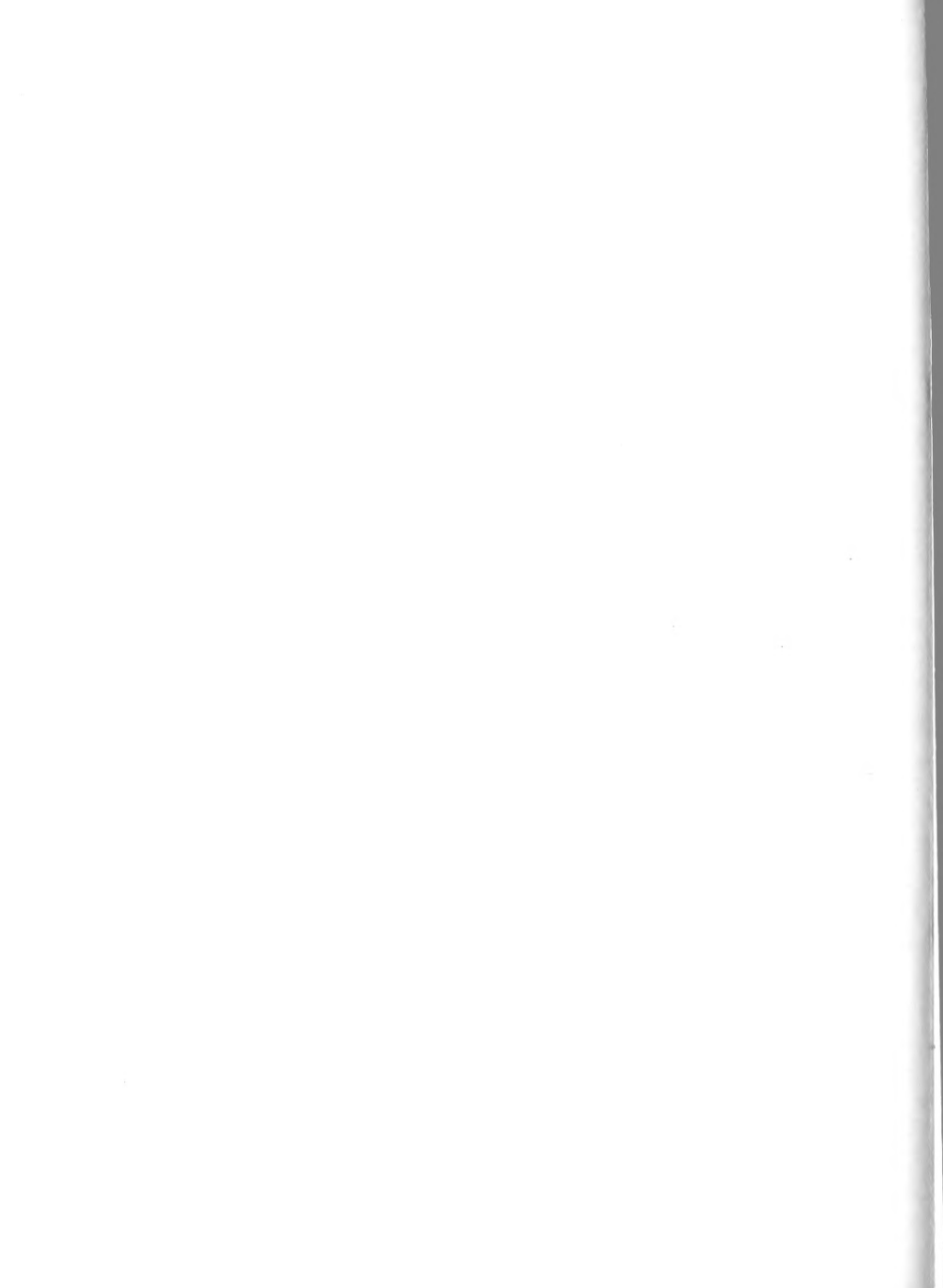


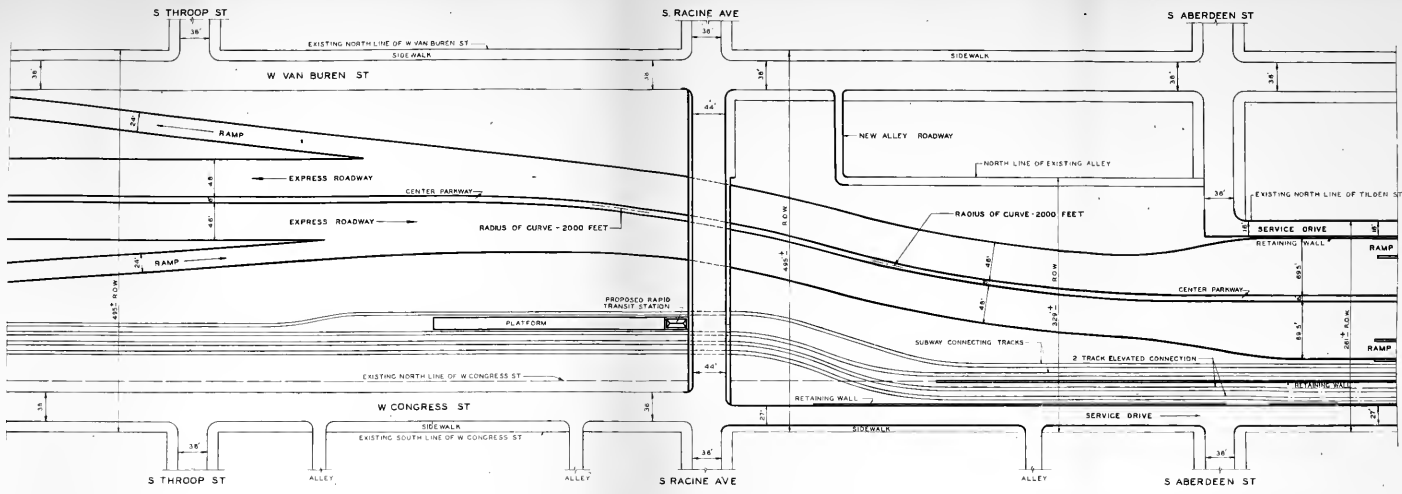
CITY OF CHICAGO
DEPARTMENT OF SUBWAYS AND TRACTION
WIDENING AND IMPROVEMENT
OF CONGRESS STREET

ALTERNATE PLAN

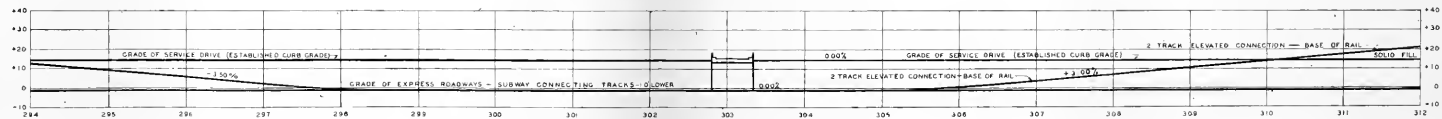
PLAN AND PROFILE
THROOP ST. TO ABERDEEN ST.

SEPTEMBER, 1939

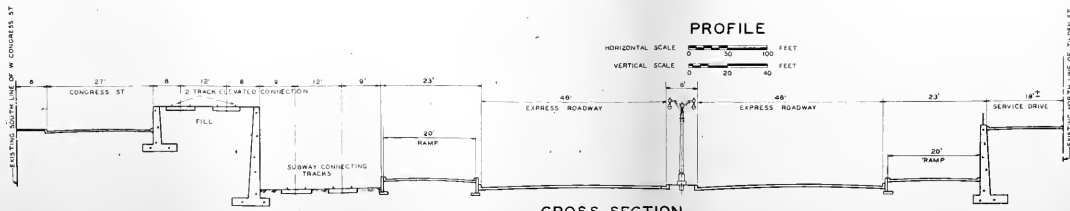




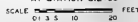
PLAN
SCALE 1" = 50 FEET



PROFILE



CROSS SECTION
AT STATION 308+00

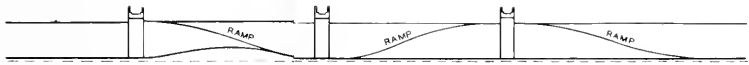
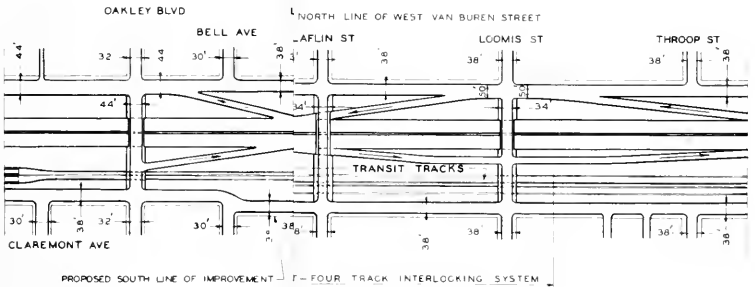
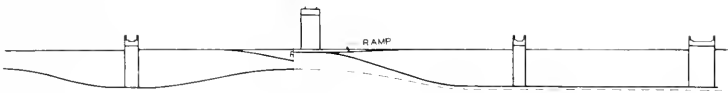
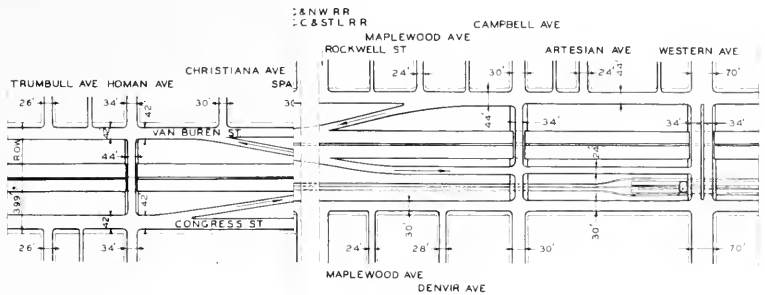


CITY OF CHICAGO
DEPARTMENT OF SUBWAYS AND TRACTION
WIDENING AND IMPROVEMENT
OF CONGRESS STREET

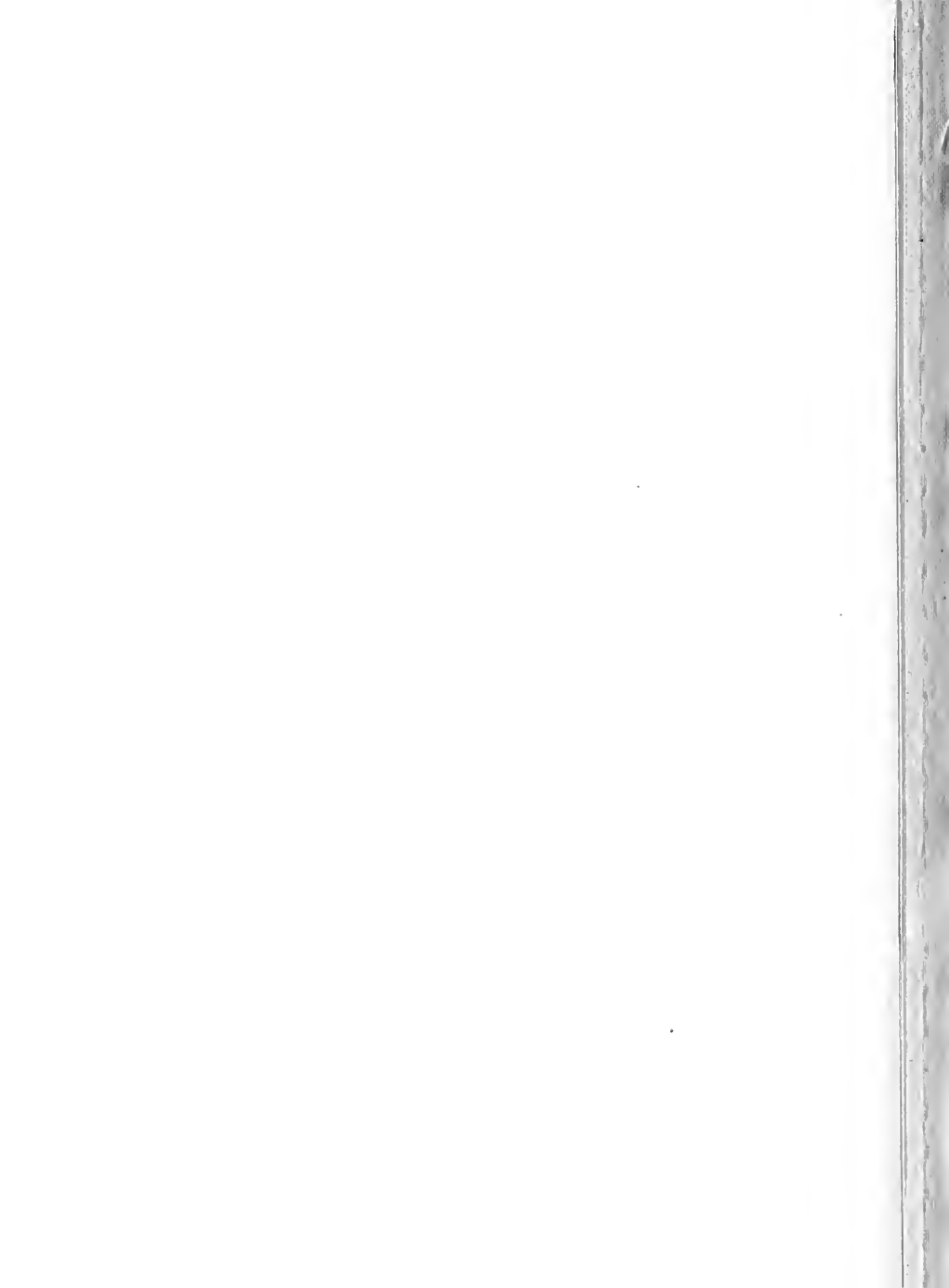
ALTERNATE PLAN
PLAN AND PROFILE
THROOP ST. TO ABERDEEN ST.

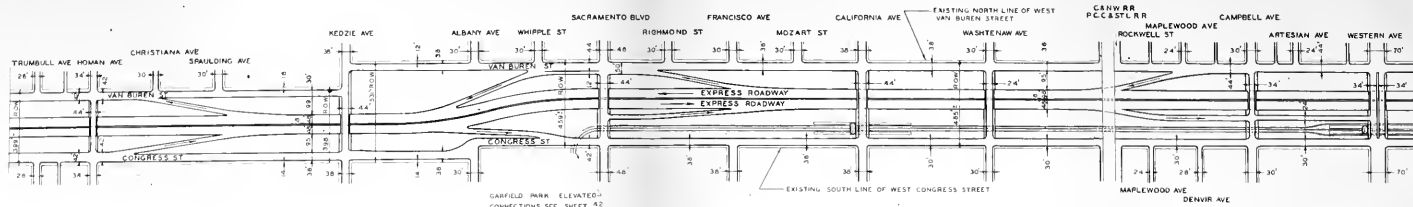
SEPTEMBER, 1939



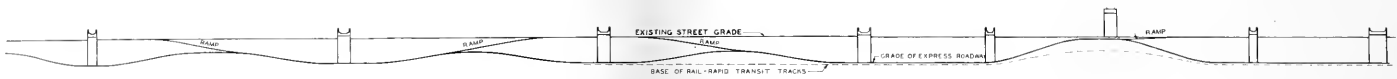


CITY OF CHICAGO
 DEPARTMENT OF SUBWAYS AND TRACTION
 A SUGGESTION FOR THE DEVELOPMENT
 OF A WEST SIDE SUPERHIGHWAY
 ALTERNATE PLAN
 PLAN AND PROFILE
 KEDZIE AVE. TO THROOP ST.
 SEPTEMBER, 1939

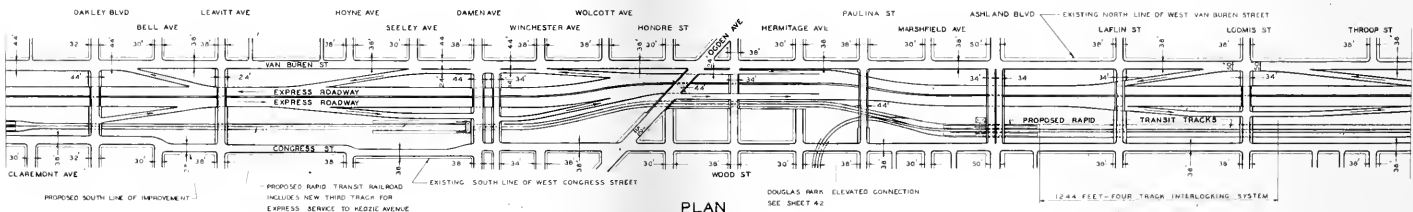




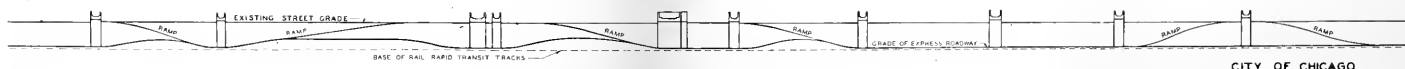
PLAN



PROFILE



PLAN

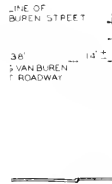
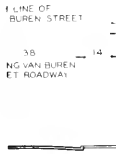


PROFILE



CITY OF CHICAGO
 DEPARTMENT OF SUBWAYS AND TRACTION
 A SUGGESTION FOR THE DEVELOPMENT
 OF A WEST SIDE SUPERHIGHWAY

ALTERNATE PLAN
 PLAN AND PROFILE
 KEDZIE AVE. TO THROOP ST.
 SEPTEMBER, 1939

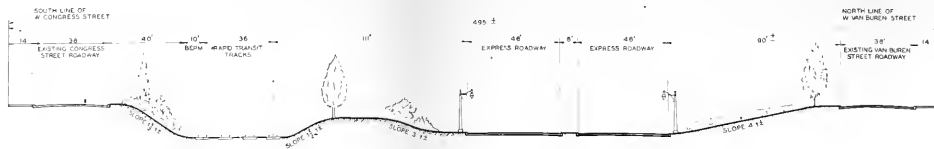


CITY OF CHICAGO
 DEPARTMENT OF SUBWAYS AND TRACTION
 A SUGGESTION FOR THE DEVELOPMENT
 OF A WEST SIDE SUPERHIGHWAY

ALTERNATE PLAN

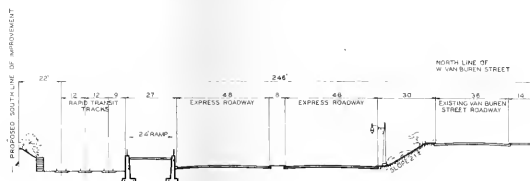
TYPICAL CROSS SECTIONS

SEPTEMBER, 1939



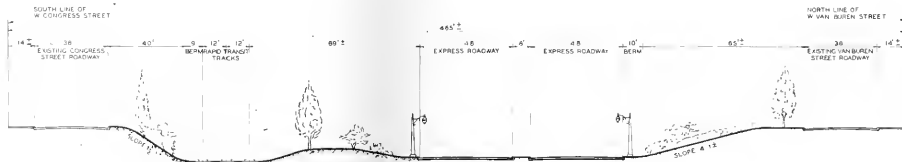
TYPICAL CROSS SECTION
ASHLAND BLVD TO RACINE AVE

SCALE 0 5 10 20 40 FEET



TYPICAL CROSS SECTION
OGDEN AVE TO WOOD ST

SCALE 0 5 10 20 40 FEET



TYPICAL CROSS SECTION
KEDZIE AVE TO DAMEN AVE

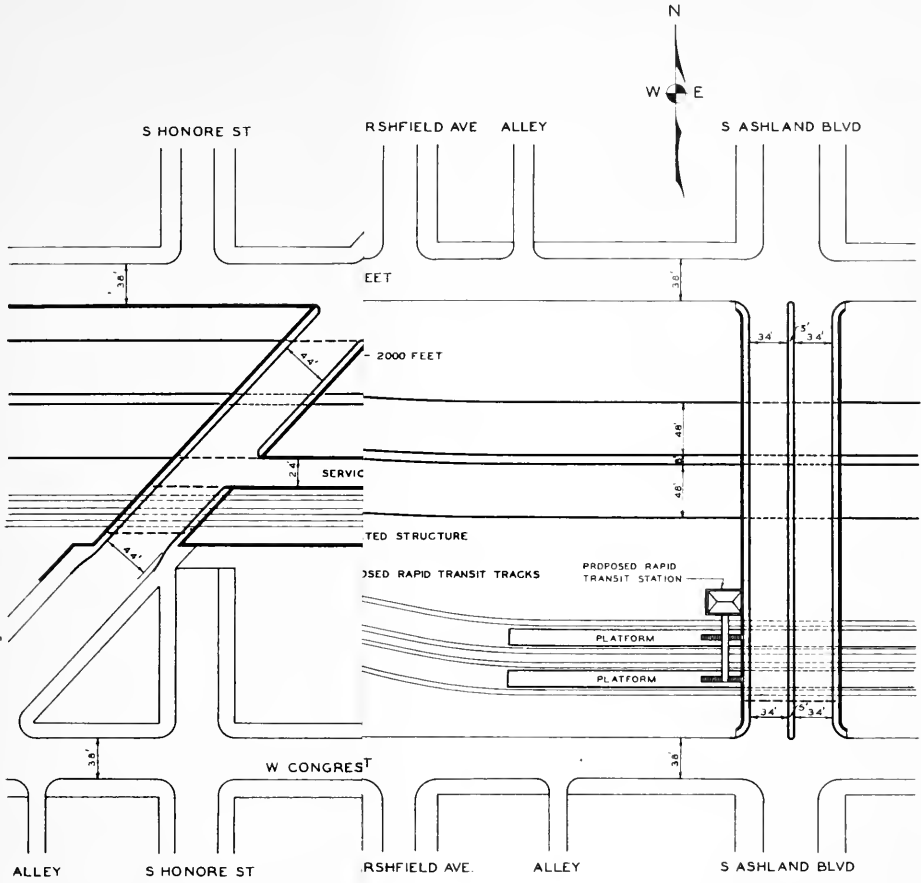
SCALE 0 5 10 20 40 FEET

CITY OF CHICAGO
DEPARTMENT OF SUBWAYS AND TRACTION
A SUGGESTION FOR THE DEVELOPMENT
OF A WEST SIDE SUPERHIGHWAY

ALTERNATE PLAN

TYPICAL CROSS SECTIONS

SEPTEMBER, 1939

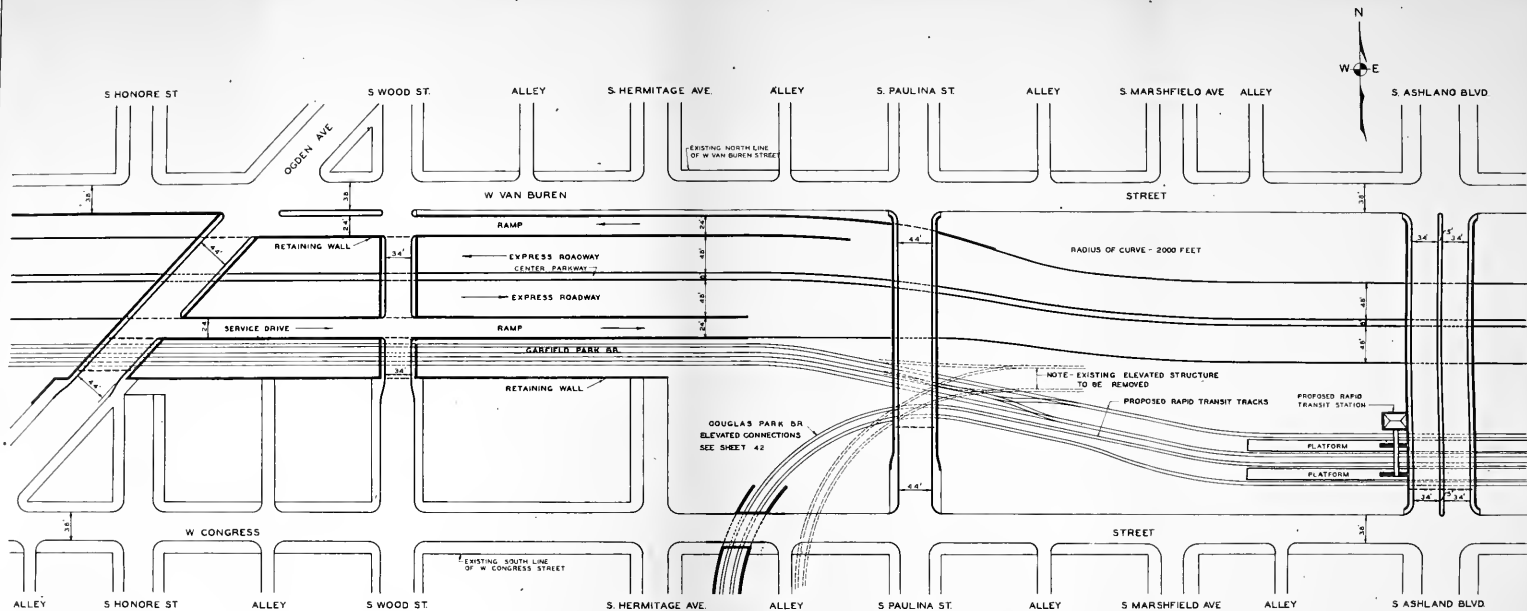


CITY OF CHICAGO
 DEPARTMENT OF SUBWAYS AND TRACTION
 WIDENING AND IMPROVEMENT
 OF CONGRESS STREET

ALTERNATE PLAN

DETAIL - OGDEN AVE. TO ASHLAND BLVD.

SEPTEMBER, 1939

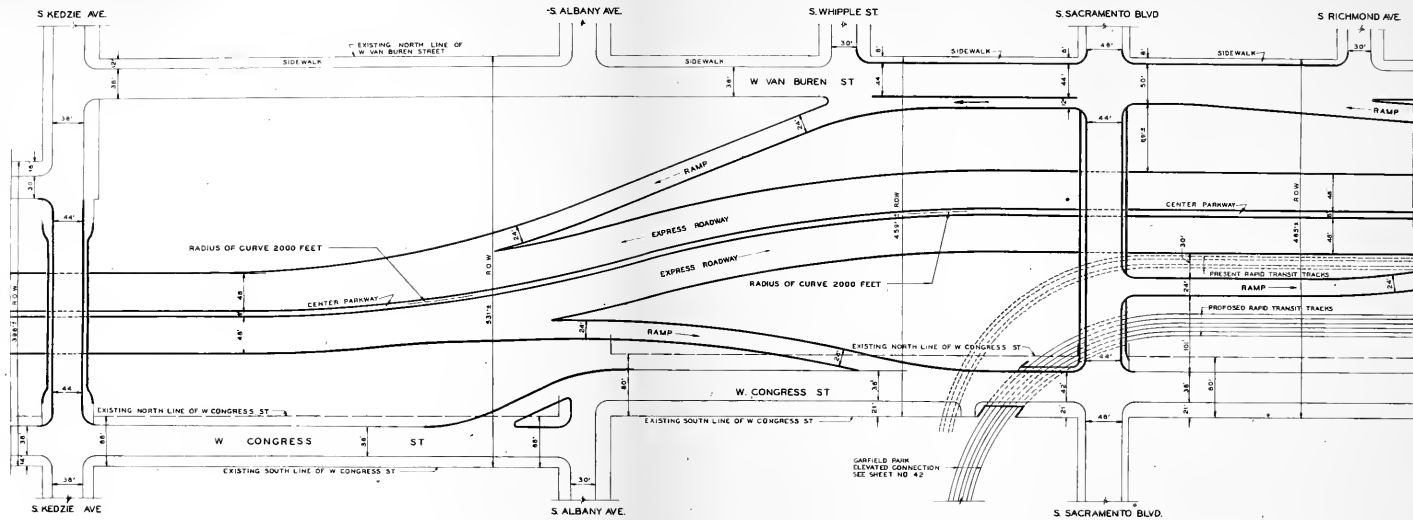


PLAN

SCALE 0 50 100 FEET

CITY OF CHICAGO
 DEPARTMENT OF SUBWAYS AND TRACTION
 WIDENING AND IMPROVEMENT
 OF CONGRESS STREET
 ALTERNATE PLAN
 DETAIL - OGDEN AVE. TO ASHLAND BLVD.
 SEPTEMBER, 1939





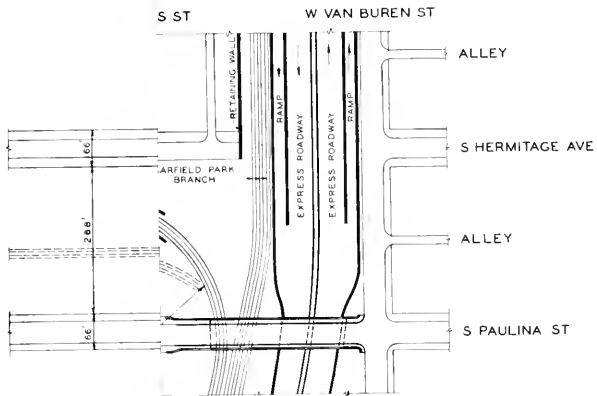
SCALE 0 25 50 100 FEET

CITY OF CHICAGO
DEPARTMENT OF SUBWAYS AND TRACTION
A SUGGESTION FOR THE DEVELOPMENT
OF A WEST SIDE SUPERHIGHWAY

ALTERNATE PLAN

DETAIL - KEDZIE AVE TO
SACRAMENTO BLVD.

SEPTEMBER, 1939



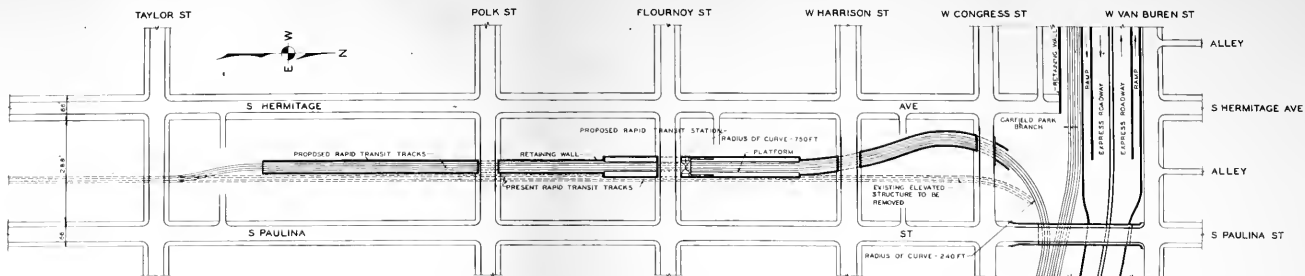
LAYO



CITY OF CHICAGO
 DEPARTMENT OF SUBWAYS AND TRACTION
 A SUGGESTION FOR THE DEVELOPMENT
 OF A WEST SIDE SUPERHIGHWAY
 ALTERNATE PLAN

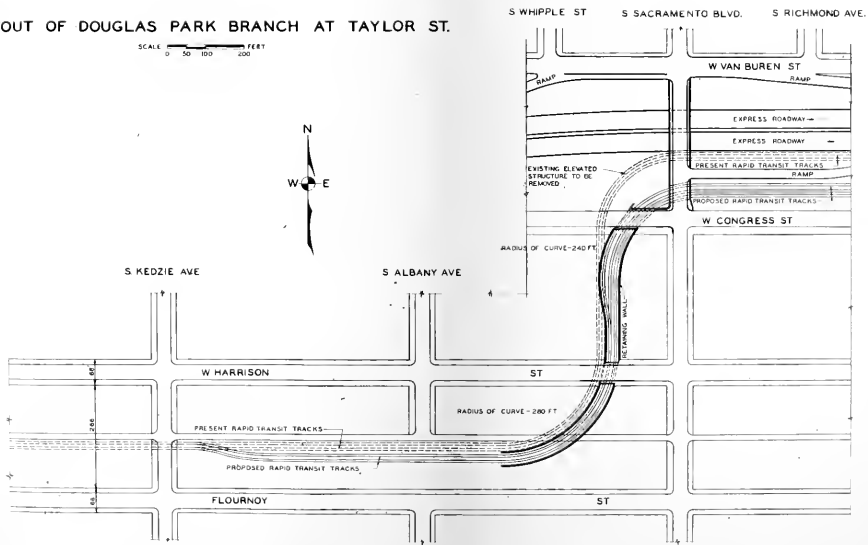
DETAIL - ELEVATED INCLINES

SEPTEMBER, 1939



LAYOUT OF DOUGLAS PARK BRANCH AT TAYLOR ST.

SCALE
0 50 100 200 FEET



LAYOUT OF GARFIELD PARK BRANCH AT KEDZIE AVE.

SCALE
0 50 100 200 FEET

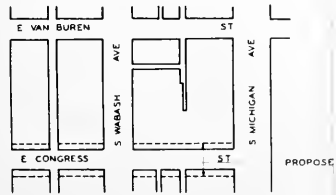
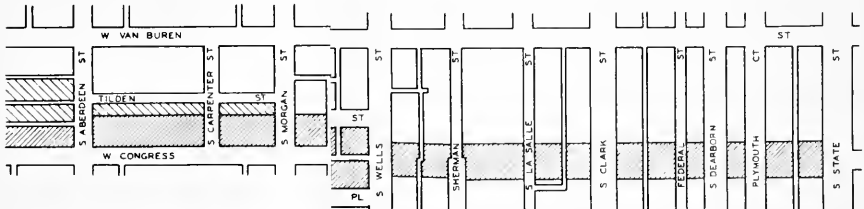
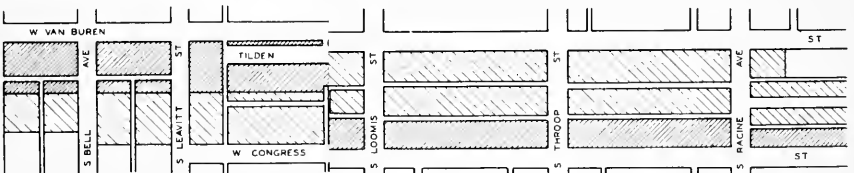
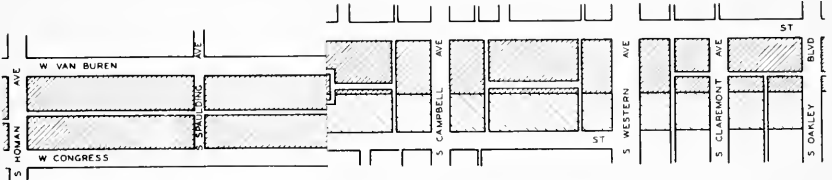
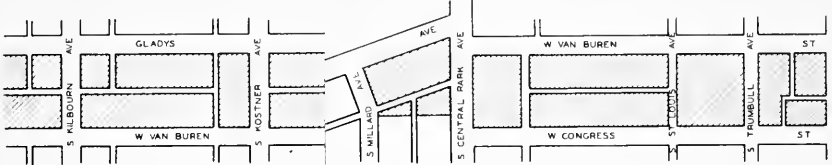
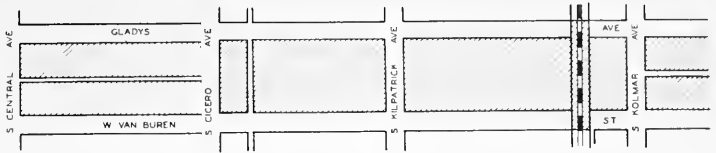
CITY OF CHICAGO
DEPARTMENT OF SUBWAYS AND TRACTION
A SUGGESTION FOR THE DEVELOPMENT
OF A WEST SIDE SUPERHIGHWAY

ALTERNATE PLAN

DETAIL - ELEVATED INCLINES

SEPTEMBER, 1939

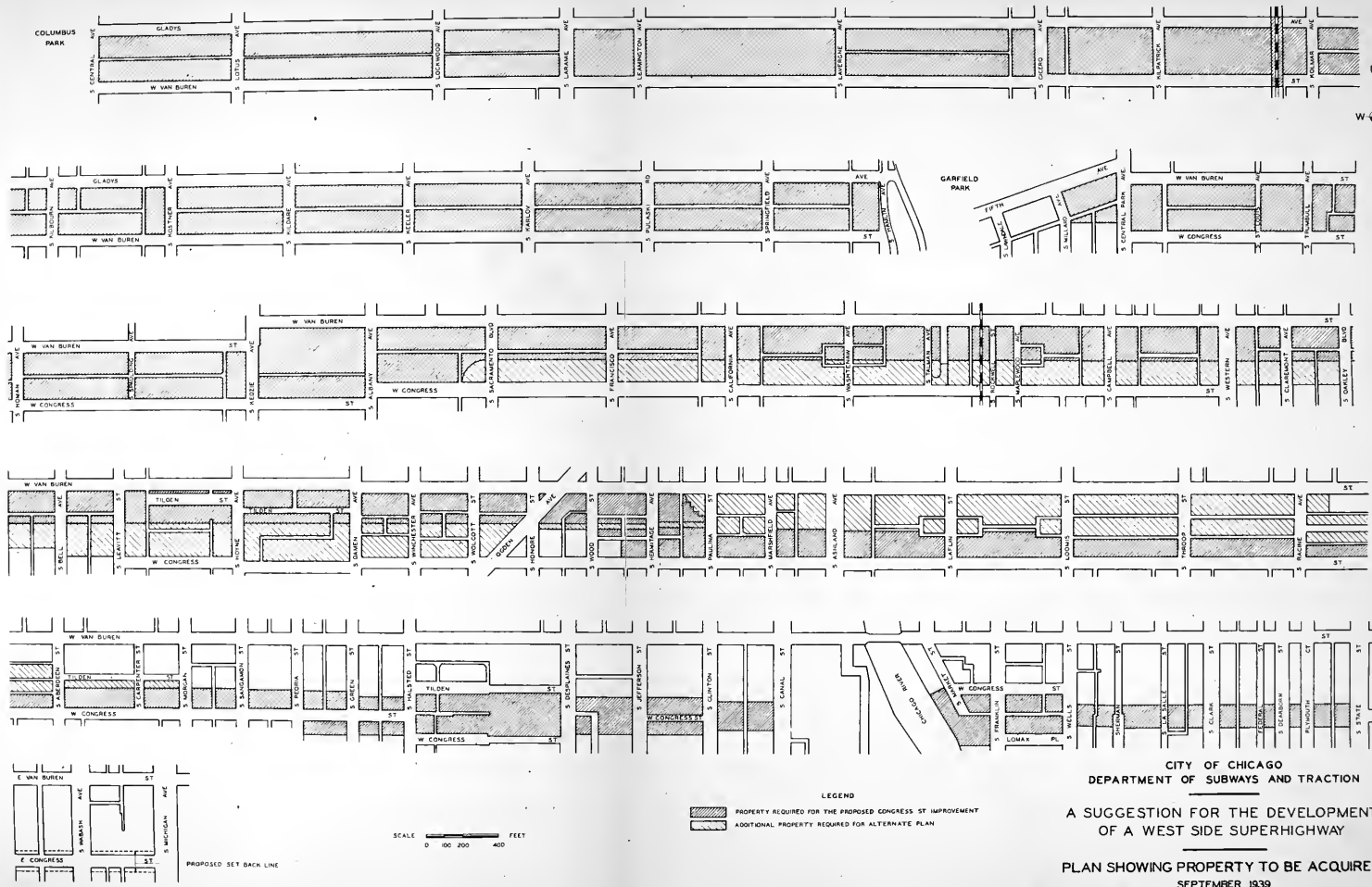
COLUMBUS
PARK



CITY OF CHICAGO
DEPARTMENT OF SUBWAYS AND TRACTION

A SUGGESTION FOR THE DEVELOPMENT
OF A WEST SIDE SUPERHIGHWAY

PLAN SHOWING PROPERTY TO BE ACQUIRED
SEPTEMBER, 1939



CITY OF CHICAGO
DEPARTMENT OF SUBWAYS AND TRACTION

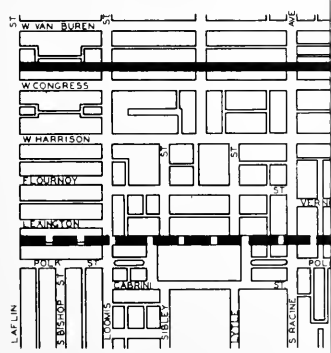
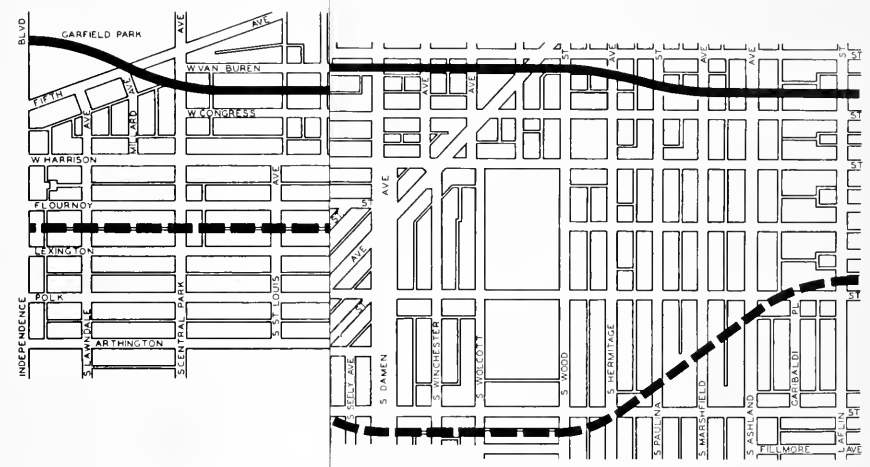
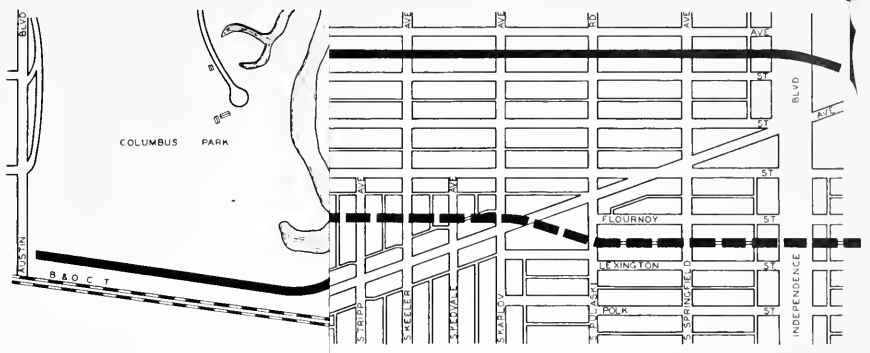
A SUGGESTION FOR THE DEVELOPMENT
OF A WEST SIDE SUPERHIGHWAY

PLAN SHOWING PROPERTY TO BE ACQUIRED
SEPTEMBER, 1939

LEGEND

- PROPERTY ACQUIRED FOR THE PROPOSED CONGRESS ST IMPROVEMENT
- ADDITIONAL PROPERTY REQUIRED FOR ALTERNATE PLAN

SCALE 0 100 200 400 FEET

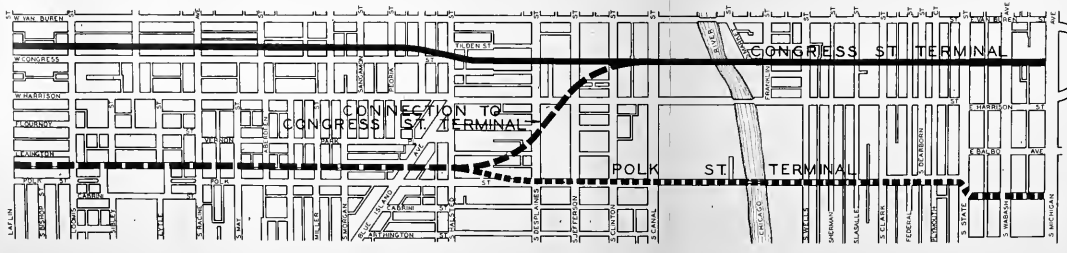
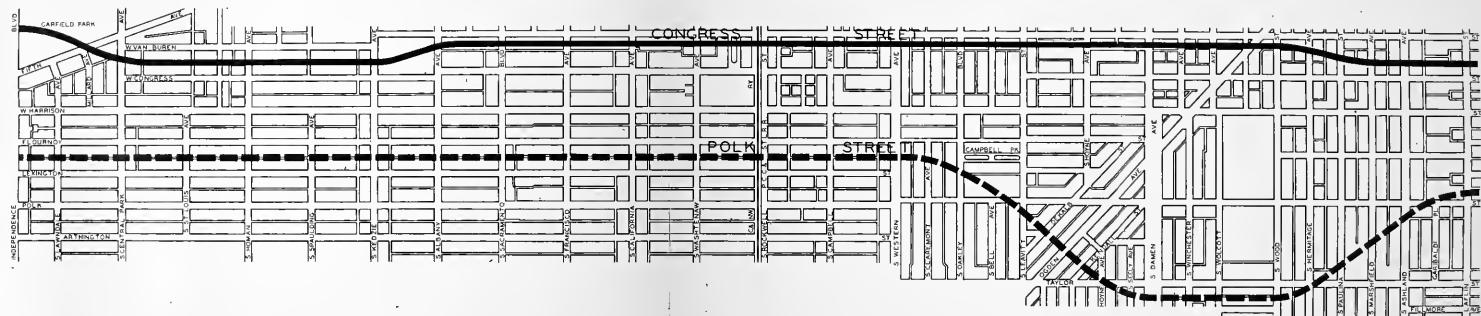
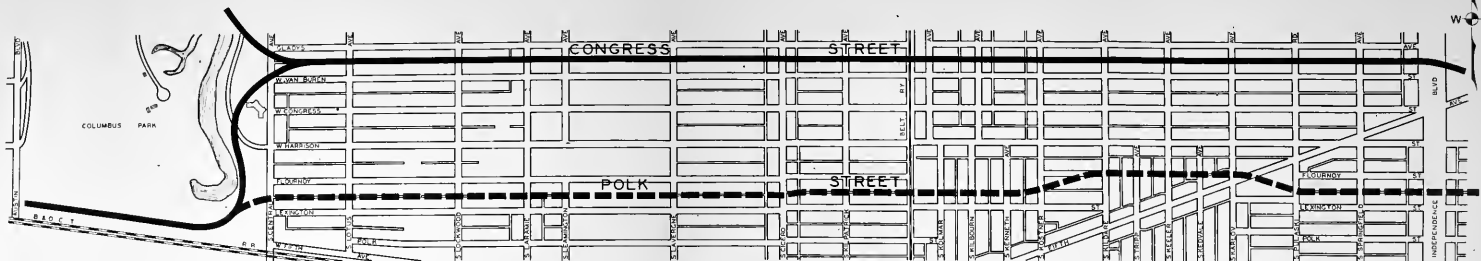


CITY OF CHICAGO
 DEPARTMENT OF SUBWAYS AND TRACTION

A SUGGESTION FOR THE DEVELOPMENT
 OF A WEST SIDE SUPERHIGHWAY

GENERAL PLAN
 SHOWING ALTERNATE ALIGNMENTS

SEPTEMBER, 1939



SCALE 0 200 400 600 FEET

CITY OF CHICAGO
 DEPARTMENT OF SUBWAYS AND TRACTION
 A SUGGESTION FOR THE DEVELOPMENT
 OF A WEST SIDE SUPERHIGHWAY
 GENERAL PLAN
 SHOWING ALTERNATE ALIGNMENTS
 SEPTEMBER, 1939

