

UC-NRLF



#B 71 974

CONCRETE

FOR

House, Farm, and Estate.

By FRED BALLARD.



1911

London :

CROSBY LOCKWOOD AND SON.

YC 68195



THE LIBRARY
OF
THE UNIVERSITY
OF CALIFORNIA

PRESENTED BY
PROF. CHARLES A. KOFOID AND
MRS. PRUDENCE W. KOFOID

1

CONCRETE FOR HOUSE, FARM,
AND ESTATE.

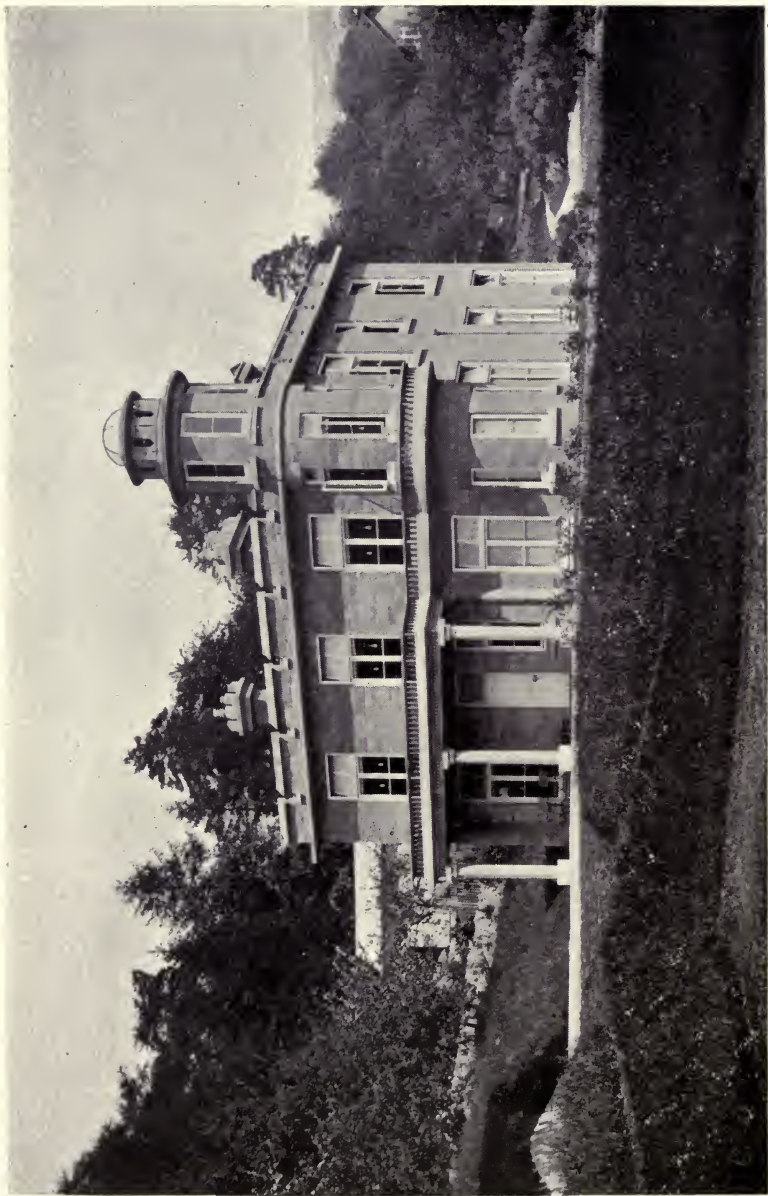

Fig. 1.—House designed and constructed by Fred and Beatrice Ballard. Walls of hollow concrete blocks 18" long, 9" deep, 6" wide. Solid floors and roof reinforced with $\frac{1}{2}$ " round bars and wire. Built in 1907.

Frontispiece.

CONCRETE
FOR
HOUSE, FARM, & ESTATE.

BY
FRED BALLARD.



LONDON
CROSBY LOCKWOOD AND SON,
7 STATIONERS' HALL COURT, LUDGATE HILL, E.C.,
and 5 BROADWAY, WESTMINSTER, S.W.

1919

DEDICATION.

TO THE
MEMORY OF MY FATHER,

THE LATE STEPHEN BALLARD, M.I.C.E.

TO WHOSE INSTRUCTION MORE THAN THIRTY YEARS
AGO IN ENGINEERING AND CONCRETE WORK
I OWE SO MUCH.

ALSO,

IN PLEASANT RECOLLECTION OF MY MEETING,
IN NEW YORK, WITH MY COUSIN,

THE LATE ROBERT BALLARD, M.I.C.E.

WHO WAS FOR
SOME TWENTY YEARS ENGINEER - IN - CHIEF
TO THE QUEENSLAND GOVERNMENT.

PREFACE.

AN elementary knowledge of reinforced concrete should form part of the education of an Architect and Builder. There is evidence on all sides that in Great Britain we have not fully grasped the advantages that concrete gives. There are few builders that can afford to neglect the cheapest and best methods, and concrete can in a variety of ways be blended into building construction.

A 'taste' for improved forms may easily lead far beyond the 'ideas' in this book, but if my efforts at construction, extending over many years and explained here to the best of my ability, will in any way help the beginner, then my labour will be to me a gratifying success.

FRED BALLARD.

Colwall, Malvern.

CONTENTS.

	PAGE
ATMOSPHERICAL CONDITIONS	7
APPLE STORE	46
AGGREGATE	8
BEAMS	13
BULL'S HOUSE	39
COST OF CONCRETE CONSTRUCTION	4
CONCRETE AND FIRE RESISTANCE	5
CONCRETE MIXING	5
CEILINGS	15
CHIMNEY HEADS	16
COPING	43
CONCRETE BLOCKS	25
CULVERTS AND PIPE COVERS	38
DOOR AND PARTITION	38
DITCHES	43
DRINKING TANK	44
DURABILITY OF CONCRETE	1
FARM BUILDINGS	29
FLOORING ON CONCRETE	20
FLOORS AND FOUNDATIONS	8
GATE-POST AND STYLE	40
GULLEYS	25
GARDEN KERB	48

CONTENTS.

	PAGE
INSPECTION PITS	25
MANGERS	34
MOULDS, WOOD	26
PONDS AND DAMS	23
PREPARATION OF TIMBER	26
REINFORCED CONCRETE	2
RATS	12
ROOFS	15
RESERVOIRS	20
RAT-PROOF GRANARY	33
STAIRCASES	27
SUNKEN LATCH-CATCH	45
WALL CONSTRUCTION	12
WINDOW SILLS	18
WINDOW HEADS	19
WALL AND COPING	43

ADVERTISEMENTS.

GREAVES, BULL, AND LAKIN, LTD.	50
WILLIAM PEARCE	51
RANSOME-VERMEHR MACHINERY CO., LTD.	52
LIMMER ASPHALTE PAVING CO., LTD.	53
PARKER, WINDER, AND ACHURCH, LTD.	54

LIST OF ILLUSTRATIONS.

	PAGE
APPLE STORE	46
BEAM	14
BULL'S HOUSE	39
CEILING	16
CHIMNEY HEAD	17
CULVERT	39
COPING	43
CONCRETE WALL AND HEAD	45
CONCRETE PILLARS	32
COW STALLS	33
DAM	22
DITCH	44
DRINKING PLACE	29
DRINKING TANK	45
DOOR AND PARTITION	38
FARM BUILDINGS	29-31
FLOOR	9
GATE-POST	41
GRANARY	33
GARDEN KERB	48
HOUSE OF CONCRETE BLOCKS	<i>frontispiece</i>
HOUSE OF CONCRETE BLOCKS	25

LIST OF ILLUSTRATIONS.

	PAGE
HOUSES	50
MANGERS	35-37
PONDS	24
ROOF	16
STAIRCASE	28
STABLE EXTENSION	40
STAND-PIPE	24
STRUTTING	11
TAR TANK IN CONCRETE	45
WALL ON PIERS	42
WALL AND LATCH-CATCH	47
WINDOW-SILL	18
SILL-BOX	19

INTRODUCTION.

THIS small volume was ready for publication just on the outbreak of the great European War. The Building Trade will probably suffer more than many industries through a general rise in the price of raw materials, especially timber, which for many years has steadily gone up in price and never got easier to buy.

The rebuilding of Belgium and part of France, with the still urgent need of decent cottages in rural England, will all be pressing points after the War. The demand for timber will exceed supply and for years to come the price will be high. Timber is not easy to substitute for doors, windows, cupboards and furniture, and if the demand for timber was confined more to these wood-work essentials, timber and even bricks might be largely excluded from general construction work in buildings by substituting reinforced concrete.

Sand and gravel, that formed the largest bulk of concrete, are articles requiring little preparation for use beyond labour; bricks require burning, so does cement, but the proportion of the manu-

INTRODUCTION.

factured article by 'cement' is proportionately much less than a solid brick wall. A five-inch concrete wall is a stronger wall than a nine-inch brick wall. An undoubted gain is made in the material used and the reduction in bulk. A flat concrete roof, always best, now leaps to the front by entire exclusion of timber.

The prime cost of building might be brought nearer the ante-War period, and in many cases actually less. I have myself constructed some cheap buildings during this period of high prices.

An aggregate of concrete composed of nine of gravel and sand to one of cement will make good walls, and with ordinary reinforcement five inches is quite thick enough. The reduction of cement and the increase of gravel makes a rough surface and a more porous wall than the richer mixture, which is a decided advantage in order to obtain a warm house. I well remember, as senior partner of the largest blue-brick industry in England, a man wanted a warm and dry office; he constructed it of hard blue Staffordshire bricks, *absolute!y non-absorbent*: the result was that the walls were never dry, the cold-condensing surface kept the place damp and often made the inside plaster stream with water. Such would be the case with a dense and a very hard cement wall. A good building brick will often absorb its own weight after being

INTRODUCTION.

totally immersed in water. Porosity in wall-
building is essential for warmth and dryness. At
first sight this may seem impossible, but the
comparison of a sheet of glass after a frosty night
with the inner walls will help to exemplify this
fact.

After construction of house walls described,
the outside should be made as impervious as
possible, and with three-quarters of an inch of well-
put-on cement plaster this may be effected. The
interior plaster should be made of common lime
and sand; *it is soft and warm, it is old-fashioned
but good*, and superior to the many hard-setting
concoctions that the market abounds with. The
using of a weak aggregate necessitates thorough
mixing, and it must be insisted that a rotary
mixer be used in such cases. Although this
proportion is suitable for walls, it would not be
advisable to reduce the strength of the aggregate
for floors and roofs below six to one.

Window frames and door jambs in wood may
be dispensed with if proper care is taken in keeping
the walls upright. Reveals can also be made
during construction. If the wooden framework
for moulding the concrete in can be duplicated, as
in the case of cottages, from a good model, the
expense compared with a single dwelling is
avoided. The cheapest form of framework is
matchboard shutters braced like a ledged door

INTRODUCTION.

and 11 in. \times 1½ in. planks being used outside and tied by screw pins and clips to the inside shutters, the planks being placed in position as the work progresses.

The actual construction of a concrete wall is more rapid than ordinary brickwork. Concrete is *composed of home material. Its all-round production and cost is mainly labour. With unskilled labour and a good foreman excellent results may be obtained.*

F. B.

Colwall, March, 1919.

CONCRETE FOR HOUSE, FARM, AND ESTATE

CONCRETE in many forms has been in use from the time of the Romans, but the construction of reinforced cement concrete is of modern date. Many useful works are published on reinforced concrete, and by carefully following elaborate formulæ based on algebraical calculations, good results may be obtained. In many engineering schemes concrete is making great strides, but its application to buildings in this country is peculiarly slow. This small work is intended to help the estate manager, the builder, the bricklayer, and even the labourer, and to give some examples of work that have been carried out successfully.

VALUE OF CONCRETE FOR DURABILITY AND NON-DEPRECIATION.

A material like concrete, that will harden and improve for several years after construction, gives an advantage only to be known to command use. By concrete construction, depreciation can often be reduced almost to a vanishing point, especially when compared with timber used in a similar position. Depreciation, indeed, is a figure that no

CONCRETE FOR HOUSE, FARM, AND ESTATE.

accountant can lightly pass over, and any owner of property soon learns the meaning of the word.

REINFORCED CONCRETE.

What is reinforcing concrete? A system of adding iron or steel to concrete, and thereby increasing the tensile strength four or five-fold. In brick and stone construction, where compression is the object aimed at, timber or iron supplies the tensile properties required. Reinforced concrete introduces into construction that which is lacking in brick and stone-work. Tension by wood and iron joined to ordinary masonry has supplied the deficiency in bricks and stone, but the blend has never been a happy one. Materials having different expanding properties often in a large measure defeat the end that should be aimed at; perfect homogeneity cannot exist with wood and bricks or heavy iron. Reinforced concrete is monolithic—tension, compression, expansion and contraction being well balanced—and distribution of stress and strain can be fairly adjusted—therefore reinforced concrete stands for sound construction.

In the varying forms of concrete construction, especially in ordinary estate work, it is not always practicable to work out to plan and scale the details of reinforcement necessary in ordinary repairs. A foreman or workman with average brains will readily learn where a strengthening rod

CONCRETE FOR HOUSE, FARM, AND ESTATE.

is required. The carpenter in constructing a gate knows where to put a tie-rod, a brace or lacer; he puts a stay to a barrow-leg: this is a form of reinforcement. The blacksmith, in making an iron fence, knows the value of a strut; he can weld a piece of iron for a bracket, and give great additional strength by his cunning at reinforcement. As a small boy I spent many hours in an estate blacksmith's shop; the sparks from the anvil were an early delight, but vividly I remember the sketches in chalk on a piece of sheet iron by a skilful engineer, and how rapidly the old blacksmith converted his iron into schemes that came from a master-mind. This example may well be followed by an intelligent foreman. Let the concrete constructor follow on the lines of the carpenter and blacksmith: he can lace, he can bracket, he can stay, he can make his framework with full knowledge that it will be welded in cement, that screws and nails and bolts are all comprised in cement. Concrete and iron blended together give a greater strength than the total strength of the same articles taken separately and added together. Experience will soon prove correctness of work; possibly some failures may go a long way to teach the constructor what to avoid and to try again, for after all there is no school so good as experience, especially when backed by a determination to succeed. 'Deserve success and you can command it.'

COST OF CONCRETE CONSTRUCTION.

The question of cost is often asked. The answer largely depends on the district. Gravel, sand, and cement have varying prices in different parts of the country ; but with modern traction delivery the use of concrete in places badly situated for material becomes possible. It is not always correct to compare the actual cost of a less durable material ; consideration must often be given to strength and durability, especially where wear and tear is excessive. There are cases where concrete is cheap, and in other cases it may be well to use it, even at a cost much above other materials : for instance, it cannot be substituted for good foundations or under floors.

A great saving in space is effected by reinforced concrete, bulk being reduced, and consequently the conveyance of materials is lessened. A 5'' concrete wall may often be an effective substitute for a 14'' brick wall, and decidedly cheaper. With a 9'' brick wall compared with a 5'' concrete wall (for it is not well to reduce this thickness) the comparison as regards cost would not be so favourable to the concrete, though the latter might be better work, and yet in many parts of the country a concrete wall might be actually cheaper than a 9'' brick wall.

If a concrete building requires plastering, the price will be increased. We have yet to find a plastering machine that can be worked like a pressure lime washer.

CONCRETE FOR HOUSE, FARM, AND ESTATE.

CONCRETE AND FIRE RESISTANCE.

In every case where concrete is substituted for wood, the risk by fire is reduced. In public buildings and where there are large concourses of people the use of concrete for floors and stairs should be made imperative. The trouble and expense entailed by a farm fire, especially in connection with dairy cattle, cannot be fully covered by insurance. Concrete will not burn, and if a combustible product like hay or straw gets on fire, it is an advantage for the building to remain fireproof. Many practical tests go to prove that iron or steel reinforcement when covered by some $\frac{3}{4}$ " of concrete is safe from fire. The construction by large steel girders is always a source of danger in a fire. Many fires are due to timber in the actual construction of a building which provides the fuel and heat to destroy both the building and its contents: the latter may not be of a very highly inflammatory nature, and yet utterly destroyed by the combustion of the house. It would be difficult to burn scattered furniture or books without fire from another source. With concrete floor and roof, a fire will probably be confined to the room or compartment in which it originated.

CONCRETE MIXING.

Too much importance cannot be attached to the efficient mixing of concrete. Badly mixed concrete will defeat well-designed work, and though

CONCRETE FOR HOUSE, FARM, AND ESTATE.

careful reinforcement will in some measure help bad mixing, it will never supply the full strength or the correct bond between iron and cement. The adhesive power between cement and iron should be at its best. No mixing by hand can equal that supplied by a rotatory concrete mixer; it reduces labour and increases speed. Quickness is essential in mixing, and a machine properly worked admits of spreading or using the matrix before the initial set has started. To get concrete into position on the first intention of setting means greater strength, and consequently saving of material. A badly-mixed cement of 1 to 4 may not be equal to a well-mixed 1 to 8. No large work should be without a good type of mechanical mixer, and even where the work is irregular and intermittent, machine mixing would generally pay. It is an easy matter with a machine to get the correct gaugings of cement, gravel, and sand. The control of the machine should be left in one man's hands, the most reliable man of a gang being picked for this purpose, for it must be borne in mind that not every man can be relied upon for good work, and even good workmen sometimes do not care to be taken out of their course.

There are cases where hand-mixing must be resorted to, and care should be taken first to mix the whole of the material dry; it should be completely turned over with the shovel three times, and a man with a three-tined rake should regularly stir

CONCRETE FOR HOUSE, FARM, AND ESTATE.

the ingredients as they are being turned. The water, which should be clean, should be applied with a can with a rose, and applied so that the cement is not swilled or the finer portions washed off the mixing-board: three turnings are again necessary after applying the water. It is assumed that no good mixing is ever attempted on the bare earth.

Concrete after mixing should be tough and plastic; if pressed by the foot, it should show a jelly consistency. Clean sand and gravel are very important items; sometimes sand may be so clean that it is too gritty and will not fill up all the cavities; it would be a mistake to use this class of sand alone. Finely-ground limestone forming one part is an excellent blend, and when thoroughly mixed with one of keen sand, two of chippings and one of cement, will make a dense and often water-proof job.

No matter how well concrete is mixed, it is most important in laying it down to get it firm and compact; ramming is usually resorted to, but nothing is equal to a garden roller on a flat surface which should be used to press out the water and consolidate the mass.

ATMOSPHERICAL CONDITIONS.

Extremes in temperature during the construction of concrete work must be guarded against. In periods of slight frosts, a covering with

CONCRETE FOR HOUSE, FARM, AND ESTATE.

boards, bags, or litter will allow the work to go on without injury. In summer-time regular watering or damp cloths spread over the concrete will prevent it drying too quickly. Fresh concrete should not be exposed to a hot sun under four or five days. Damp or rainy weather should be selected as preferable for putting down concrete flats in summer time.

THE AGGREGATE.

In mixing concrete always use 2 of sand to 1 of cement, and add gravel and chippings preferably not larger than three-quarters of an inch to the extent of the strength required. If 1 to 6 is wanted, read it to mean 2 parts of sand and 4 of gravel to 1 of cement, and this is a good average strength for walls or roofs.

It may be necessary to explain the rigid formula of 2 of sand to 1 of cement. This portion of the mixture gives the adhesive qualities; it is the mortar that holds the chippings together and any alteration in the proportion will weaken this essential property.

FLOORS AND FOUNDATIONS.

One of the first forms in which concrete is often required is for foundations and floors. If concrete 1 to 6 or 8 is spread over the whole area that a building occupies and one-third of an inch square iron rods placed 9'' apart with rods at right angles every 2' the reinforcement being kept within $\frac{3}{4}$ '' of

CONCRETE FOR HOUSE, FARM, AND ESTATE.

the bottom, a sound floor space will be formed to carry walls and support upper solid floors. Iron wire and old fencing wire often come in useful for reinforcing in floor-laying.

The advantage of a solid floor does not end with

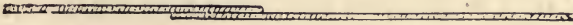

Fig. 2.

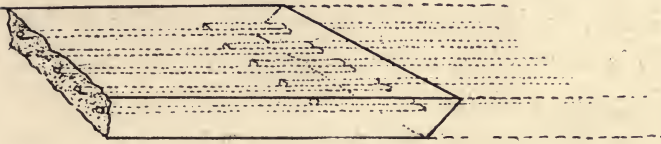

Fig. 2A.

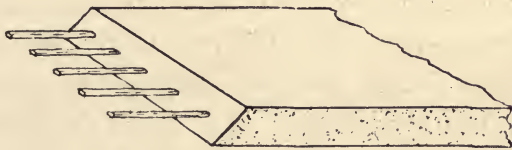

Fig. 2B.

the question of sound construction, but it renders a site freer from damp than the slovenly system of throwing in concrete between the joists at a later period.

If it is not practicable to finish a floor the same day as it is commenced, care should be taken always to leave the finished edge bevelled and consolidated, and the iron reinforcement should stand out from this bevelled edge not less than 6'' (fig. 2B) to receive the next day's layer of

CONCRETE FOR HOUSE, FARM, AND ESTATE.

concrete (fig. 2A). In joining on fresh bars they should overlap the 6'' of outstanding iron which equals a continuous bar (fig. 2).

The finishing of a floor by screeding to a true level can be easily done by setting narrow strips of wood for the straight-edge to work on. A wood screed of a V shape is convenient to set on a rolled floor and it comes out without breaking the surface. The screeding should always be done before the bulk is set, for it is useless to expect solidity if the surface is allowed to set and get hard and then a finishing coat added.

Large sums of money are often wasted on deep foundations. A foundation 2' wide and 6'' thick reinforced by two bars longitudinally and cross-bars every 8'' will carry any ordinary building. Soft places may be bridged over in this manner while foundations at a great depth will often subside owing to being a trap for water, especially in the case of defective spouting. A continuous concrete foundation such as described would suffer little risk if it became necessary, years afterwards, to put a drain or other opening under it. The distribution of weight on a wide area is so much better than the concentration of weight on a small area; this is so obvious and yet so often neglected.

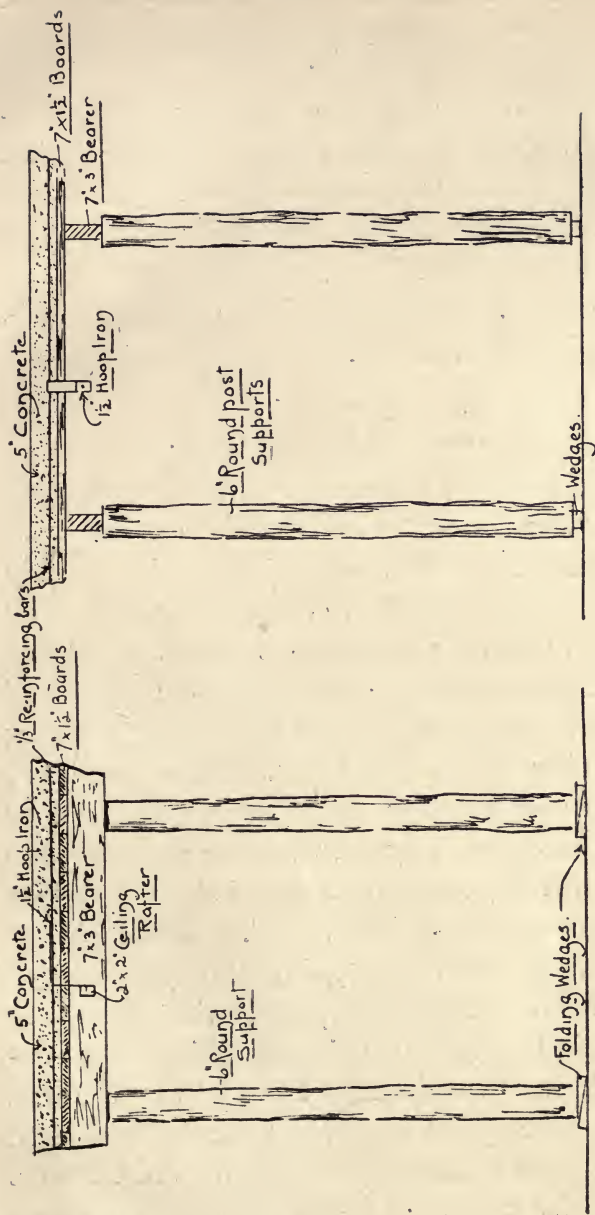

FRONT

SIDE

Fig. 3. SFRUTTING. — Sketch showing ordinary propping for a floor or roof; a few battens will keep them in position until the weight of the concrete is put on the boards.

RATS.

Under some foundations rats may be troublesome. To avoid this put a layer of broken glass under the foundation two feet wide from the outside edge. One of the few chances for rats in concrete construction is under the floor, and broken glass prevents a raid of this kind; particularly in pigs' cots is this necessary.

WALL CONSTRUCTION.

In the ordinary construction of concrete walls it is not wise to reduce the thickness below 4" or 5"; a reinforced wall of this thickness is certainly superior to a 9" brick wall against stock of all kinds, and, generally speaking, it would be slightly cheaper than brickwork. It should be reinforced by vertical bars 9" apart, and with rods or strong wire running across every 18". The framework (sometimes erroneously called false work) can be provided by deals 9" by 3", with one cut down the middle; this leaves planks a useful size for making the framework of a wall sound. Wood clamps every 4', with screw pins going through the wall and between every other plank, will sufficiently hold the timbering in position for filling with concrete. A small wood gauge the width of the wall will keep the planks adjusted until filled with concrete. Steel sheeting would, no doubt, be a substitute for wood. An iron rammer is the best

article for ramming a concrete wall. The rammer-head should be 6'' long and $1\frac{1}{2}$ '' wide, made out of a lump of iron, with a convenient handle 2' 6'' long, and the ramming should be even and regular, and continued until the concrete shows a pulpy consistence on the top, no rough gravel being in view, and to obtain this desired density the filling in should not be more than 5'' deep at one time before ramming.

BEAMS.

In most building construction the question of beams is an important factor. A broad and safe formula for a reinforced concrete beam is to calculate 1'' in depth for every foot run: thus, a beam of a 12' span would be 1' deep, and the width should be at least half the depth. A greater width with beams is often better; a 9'' width works conveniently with brickwork. A 12' beam reinforced with four bars $\frac{1}{2}$ '' square, two bars placed within $\frac{3}{4}$ '' of the bottom of the beam and 1'' from the outer edge, and two bars on the top of the beam, with four pothooks placed within 1' of the centre and connecting the bottom bars with the top ones, will suffice for any ordinary building construction. Additional strength can undoubtedly be given by bending the bottom bars at a distance of one-third from the end of the beam and taking them up to the top edge, as shown in fig. 4; the tensile and compressive forces are better met with in this manner.

CONCRETE FOR HOUSE, FARM, AND ESTATE.

The beam must be securely propped during construction; no false work, but particularly strong and sound timbering is necessary. Any jarring or vibration should be avoided until the concrete is well set, and in no case should the props be removed in less than four weeks; and if longer time can be given, it is better.

In cases of exceptional strain, and where there is any shadow of a doubt in the mind of the constructor as to the strength required for a beam, reliable information can be obtained from an expert, or many reputable firms who are manu-



Fig. 4.

facturers of metal for reinforcement, and who will supply careful details of construction.

Exceptional strains must of necessity mean exceptional treatment, and it is impossible in a work of this class to deal with the varying problems in beams that may require the very best engineering skill.

In the case of a concrete floor or roof requiring beams, the depth of the beam may be calculated from the top of the floor if the floor and beam are put in together; thus, a floor 4'' thick requiring a 12'' beam would only show 8'' under the floor level; this gain of space is often useful.

A concrete corbel, which can be easily made

CONCRETE FOR HOUSE, FARM, AND ESTATE.

under the end of a beam, gives great additional strength and spanning power.

CEILINGS.

With a solid floor where a plaster ceiling is desired, provision should be made to suspend the ceiling, for trouble often follows by plastering directly on to the concrete. Pieces of wire or hoop iron can be inserted between the planks so as to protrude some 6'' below the planks and hooked into the concrete above; the boards when taken away leave the wires ready to fix the ceiling joists to, or iron bars for a metal lath ceiling (see fig. 5). The ceiling joists can be adjusted to the pitch of the roof, so that the ceiling is level or parallel with the floor, but varies in its depth from the roof.

ROOFS.

From floor to roof is but a repetition. A concrete flat is a slight misnomer, for it should generally be pitched to one point. This form of roof is the best possible roof that modern ingenuity has devised for human dwellings, the temperature under it is more equable than is the case with slates or tiles. The area of a flat roof is much less than the area of a pitched roof and the exposure to wind is reduced to a minimum. Repairs, always troublesome and expensive when connected with an ordinary roof, are practically eliminated by a well-constructed flat (see fig. 6).

CONCRETE FOR HOUSE, FARM, AND ESTATE.

A flat roof in small sections can be made perfectly waterproof by concrete alone ; faulty places generally occur at a joint after leaving off work, and to ensure a perfect job, asphalt is the best finish, although a good class of felt may be used with success.

The garden roller should be taken on to the roof-top, and the same regular rolling and squeezing process as applied to the floor should be applied to the roof. Four weeks should be allowed before striking the timber.

A flat roof may be finished flush with the wall, but it is better to overhang 18'' or 2', and this portion should be made to pitch from the outside to the main roof. No guttering is required, only the downwater pipe, which should be large and should stand out from the wall. A short length of outlet pipe should be inserted in position so that the concrete can be placed firmly around it.

CHIMNEY HEADS.

Chimney heads are best constructed with an overhanging concrete table (see fig. 7). Chimney pots can be fixed above the table, but the actual roofing of a chimney is the most important point. There is no portion of a building subject to so much wear and tear as a chimney. It has to stand heat and water, sometimes converted into steam and at other times expanded by frost, yet no



Fig. 5.



Fig. 6.

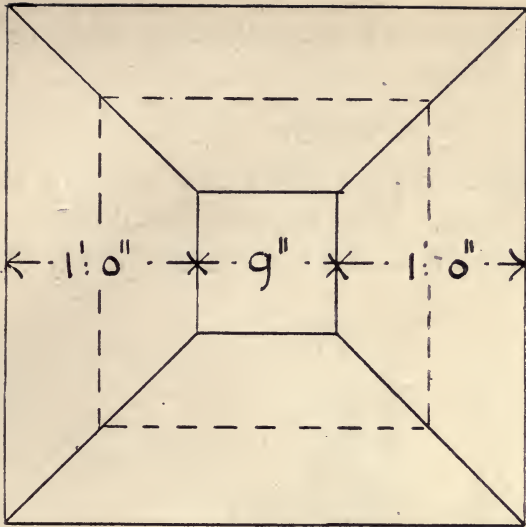

PLAN OF CHIMNEY HEAD

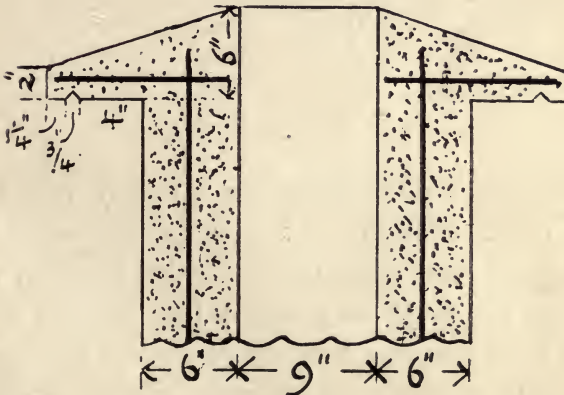

SECTION OF CHIMNEY HEAD.

Fig. 7.

portion of a house is usually worse built or more difficult to repair.

WINDOW SILLS.

Window sills are often the cause of trouble inside a house. They require careful construction. A concrete sill should not run completely through

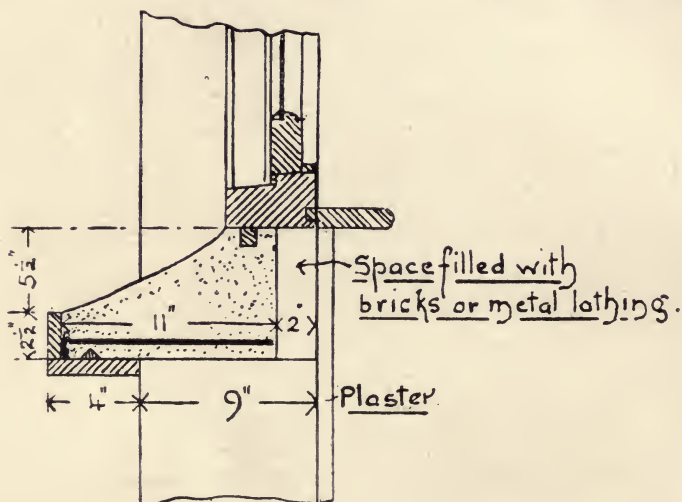

Fig. 8.

the wall, and should allow for a cavity where a wall is thick enough. It can in any case be finished with brickwork on the inside (see fig. 8). A window sill must be properly bedded, and if it is a heavy sill this is a difficult operation, therefore window sills are better to be made in position.

The construction of a sill-box (fig. 9) should be such as can be applied to various openings. It can be constructed of board, with one fixed end and

one adjustable end that can be fixed by a screw to the length of the sill required. A straight-edge should be used between the wood window sill and the outer edge of the window box, or the surface can be slightly hollowed by a curved striker. The mixture should be 1 to 4, and finished off to a good surface before it is set. There should never

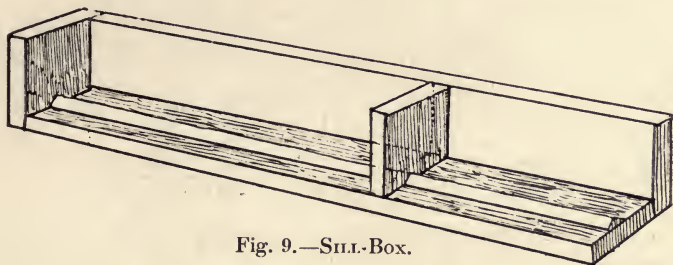

Fig. 9.—SILL-BOX.

be any attempt to put a second coat on a window sill. A V-shaped throating $\frac{3}{4}$ " wide and placed $1\frac{1}{2}$ " from the outer edge of the sill is always necessary.

WINDOW HEADS AND LINTELS.

Window heads and lintels can be made in concrete by placing planks in position and filling in to the level required. For small spans, a couple of bars of reinforcement $\frac{1}{2}$ " from the lower edge will give ample strength. In $4\frac{1}{2}$ " brick walls short beams may be made on the ground and carried into position; but, generally speaking, all concrete construction is better made *in situ*.

FLOORING ON CONCRETE.

A wood-block floor is a good finish on concrete. When flooring boards are required, strips 2'' by 2'' should be spaced like ordinary joists and laid on the floor for nailing the floor-boards to. The boards hold the strips in position without setting them in concrete.

A concrete made of coke breeze and 2'' thick, provides a surface to receive floor-board nails, but this latter system does not often commend itself.

RESERVOIR CONSTRUCTION.

The construction of reservoirs with cement concrete is usually cheaper and better than with any other material. Water pressure on ordinary brick walls is very apt to cause trouble unless the walls are strongly buttressed and constructed in very sound ground, and with brickwork it is difficult to build a wall to fit tight to the earthwork. The writer has successfully constructed several concrete reservoirs with a capacity of from 3000 to 100,000 gallons.

The earthwork should be got out carefully, with as little disturbance as possible to the ground against which the walls are going. A depth of from 6' to 8' is convenient for working. The wood planking should be on the inside of the wall, and strutted across by timbers. The floor should not be less than 5'' thick, and be reinforced and well

CONCRETE FOR HOUSE, FARM, AND ESTATE.

rolled ; the walls 6'' thick, and reinforced every 9'' in the centre of the wall with a vertical bar $\frac{1}{3}$ '' square, and at every 18'' rise on these vertical bars a horizontal bar or strong wire should be placed. The vertical bars should project 3'' to 4'' above the top of the wall to tie into the flat or roof of the reservoir, and it is well for the walls to finish above ground-level (even if the water-line is lower down), and for the flat on the top to overhang the sides 9''. In the screeding of the top of a reservoir of this description, let the middle be an inch and a half higher than the sides, to give the rain-water a fall off. A manhole should be provided in the top, 18'' by 2'; a wooden frame to this size should be placed in position on the boards before the concrete is put down, and if the top is 5'' thick, make the frame 7'' deep, and bring the concrete up to this level at a slight distance round this opening. By this process no joint is left for any contamination to get into the reservoir. The manhole, which is the highest point, is covered by a lid that should cap over an iron frame.

There is one point that must not be forgotten : if the bottom of the reservoir is put in on one day and the walls a day or so afterwards (a probable contingency), it is necessary to stud the bottom round with pieces of iron the same description as used in reinforcing the walls, putting them well into the concrete in the wall line, and allowing them to stand up 6'' above the bottom ; the ver-

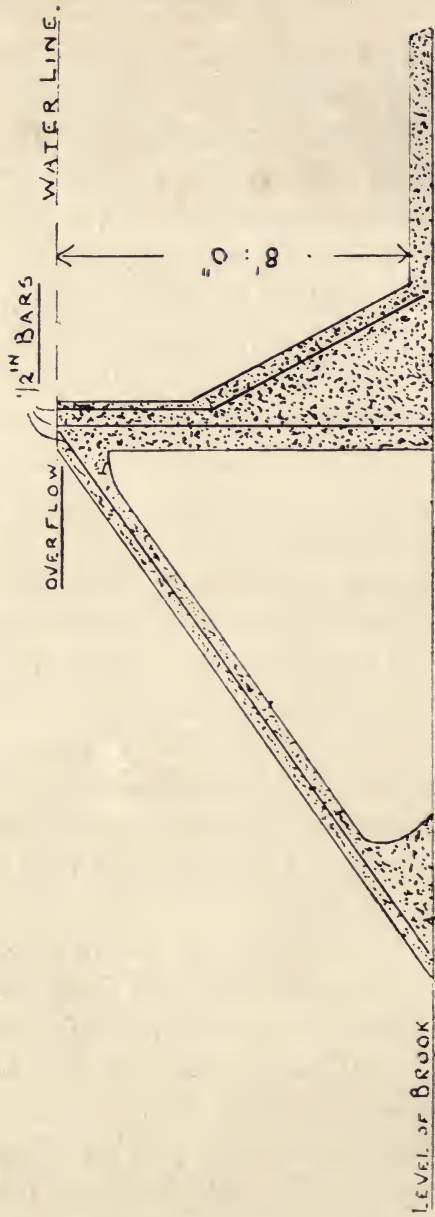

SECTION OF DAM IN BROOK

Fig. 10.

CONCRETE FOR HOUSE, FARM, AND ESTATE.

tical bars then come down against them, forming a tie equivalent to a continuous bar of iron. Short studs are better than long bars, the latter being easily knocked out of position and the cement joint between iron and concrete broken.

Large reservoir construction will entail greater strength, but work of this character may need the guidance of a special engineer.

PONDS AND DAMS.

A concrete dam in a brook can be strengthened by being buttressed inside the dam, which forms an anchor, as shown in section (see fig. 10). In case of doubtful foundations, such as are often found in the bottom of a brook, the width of the concrete foundation is important. The overflow can be made to form a strut to the wall dam. The dam should be well let in beyond the sides of the brook, or the wall may be returned obliquely. The construction of a dam often necessitates first laying a pipe to carry the water under the wall; this can be easily stopped up after the dam is ready to fill, but if an outlet-pipe in the bottom is wanted, let the valve be inside the pond, operated by an iron bar-handle in the water; this will prevent freezing, an inevitable consequence with a tap outside the water. In connection with tanks and pipes, a stand-pipe and tap in work for over forty years is worth taking note of. It has been used as a garden-supply (see

fig. 11). The $\frac{1}{8}$ " hole on the outlet side of the plug-tap keeps the exposed portion of the pipe empty a distance below ground level, and is consequently free from frost.

A garden pond may often have to be placed on a bad foundation. 6" of cement concrete 1 to 6

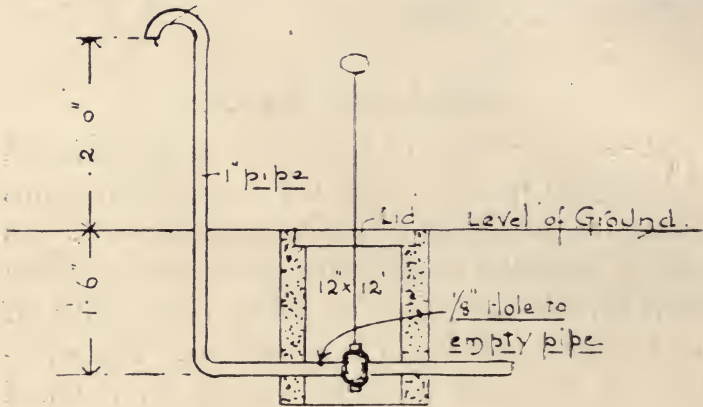

STAND PIPE PROTECTED
FROM FROST

Fig. 11.

will make a good base when reinforced under the entire surface (the reinforcement may be the same as ordinary floor-work) and the sides should be securely reinforced to the base. A cement plastering not less than $\frac{1}{2}$ " thick should be applied before the surface gets hard. A pond of this description is easily cleaned out and will not leak like puddle which is subject to cracks and tree-



Fig. 12.—POND FORMED BY CONCRETE DAM (Section 10) IN SMALL BROOK.



Fig. 13.—DAM AND WATERFALL ABOVE POND SHOWN IN FIG. 12.



Fig. 14.—A sound 'concrete basin,' bottom and sides reinforced with old iron.
(This pond is on a very bad foundation.)



Fig. 15.—House constructed of concrete blocks, floors and roof reinforced by expanded metal, with spans up to 15 feet. Inside walls solid concrete. Designed and built, in 1906, by F. Ballard and T. Armstrong.

CONCRETE FOR HOUSE, FARM, AND ESTATE.

roots, and it is certainly free from outlets made by moles, which often occur in puddle in a dry season.

GULLEY OR GRID FRAMES.

These frames may be made in the position where they are wanted and in making these small articles some form of expanded metal is useful. Smaller construction requires to be thoroughly reinforced, but the metal should be light. In using small wire or round bars, let the ends of the wire or bars be turned, to prevent slipping. For garden gulley frames a thickness of 3'' is enough. For resisting heavy carting, the strength must be greater.

INSPECTION PITS.

An inspection pit 4'' thick in concrete is of much greater strength than ordinary brickwork, and can be constructed much on the same principle as the building of a reservoir.

CONCRETE BLOCKS.

Concrete blocks find some favour for their appearance and also for speed in building. Many machines have been invented to produce blocks, but if a stone is cut to the size and face required, a plaster cast can be taken from which a reproduction can be made in cast iron. The iron frame or box should be made in two pieces, namely, the side

CONCRETE FOR HOUSE, FARM, AND ESTATE.

and end joined, and when these two pieces are fixed together by a band or angle-tie they form an oblong block ready to fill and easily taken apart. A tapered piece of wood placed in the middle will form the cavity. Houses built of concrete blocks are illustrated in figs. 1 and 15. The blocks for these houses were made in the manner that has been described. In exposed positions blocks made of concrete are not always weatherproof without a waterproofing solution, although porous blocks may be durable. The mixing of concrete for block-making is too dry, and a dense condition is difficult if not impossible under the ordinary system of block-making in a mould (they would not retain their position when taken from the mould if the concrete contained the ordinary amount of water necessary for hard setting). The blocks would be better if made out of well-mixed and wet concrete with the face downwards and left in this position to set.

WOOD MOULDS AND PREPARATION OF TIMBER.

Wood moulds are convenient for making many small articles, especially wire fencing-posts, cement slabs, &c. In the construction of moulds a slight taper is of assistance in getting the articles out; in some cases the parts are better screwed together and are thus easily released.

CONCRETE FOR HOUSE, FARM, AND ESTATE.

In all timber moulds care should be taken not to use very old timber: far better to use it green than too dry, as dry boards expand when subject to wet concrete. A coat of whitewash on new boards will prevent cement sticking to them, and it will often repay to paint a wood throating so that it leaves the concrete without doing any damage. Oil cannot be advised for this purpose. On the Continent, especially in the construction of flats, it is a common thing to see newspapers put on the boards. There is no preparation of wood to prevent shrinkage or expansion better than boiling. We have seen a wooden roller with blades fixed on the pug-mill principle for mortar-mixing sound and free from any shrinking after being made over thirty years, the secret being that the wood was boiled.

STAIRCASES.

The section of staircase from ground-level (fig. 16) shows solid block of concrete at base, with steps joined to beam. The timbering for this construction should be complete before commencing to put in the concrete, the steps being formed by riser pieces of wood to the height required and nailed on to a sideboard (a temporary string). A nosing and insertion of a wood strip for fixing stair-rod eyelets can be arranged at first construction, or put in position afterwards (see

fig. 17, in cases where a fine finish is required by the plasterer's trowel. Reinforcement should go from base to beam, and also longitudinally, in each step, with short pieces of iron obliquely placed in the steps 9'' apart. The reinforcement in the long bars may be $\frac{1}{2}$ '' square; in the short or cross bars, $\frac{1}{3}$ '' square; and all with 9'' spacing.

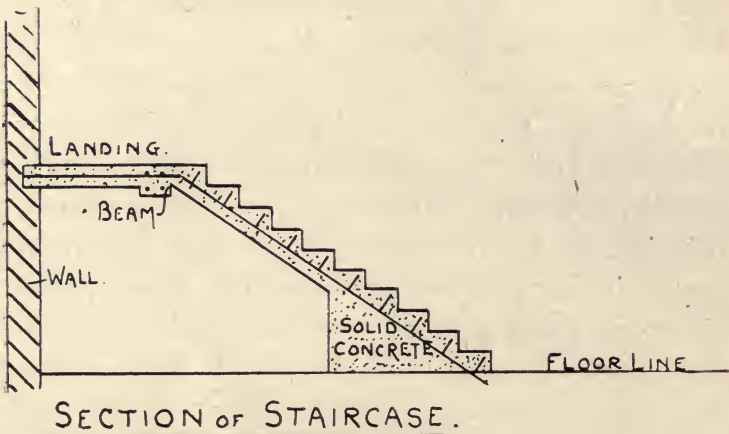

Fig. 16.



Fig. 17.—Illustration of Stairs, showing holes left for newel and balustrade.
The wood insertion for fixing stair-rod eyelets can be seen.

Face page 28.



Fig. 18.—SIR CHARLES MACARA, BART., INSPECTING SANITARY DRINKING-PLACE FOR COWS,

FARM BUILDINGS.

Concrete is particularly useful in the construction of farm buildings. It is sanitary and easily cleaned, it makes a much better floor than bricks; mangers are better and more durable in concrete than in any other material. For being rat-proof and fire-proof, no material in farm buildings can compete with concrete.

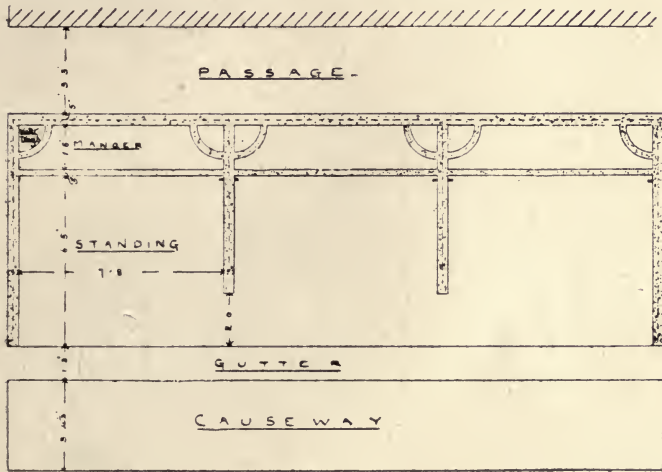

PLAN OF STALLS FOR 6 COWS.

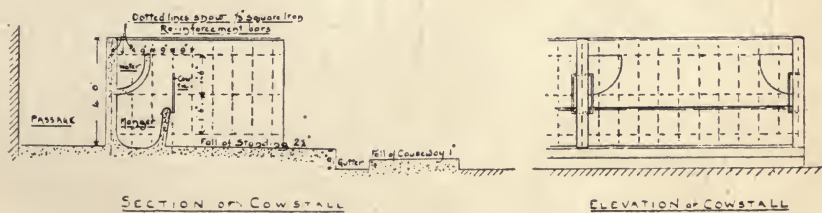

SECTION OF COWSTALL

ELEVATION OF COWSTALL

Fig. 19.—MODEL DAIRY FARM.

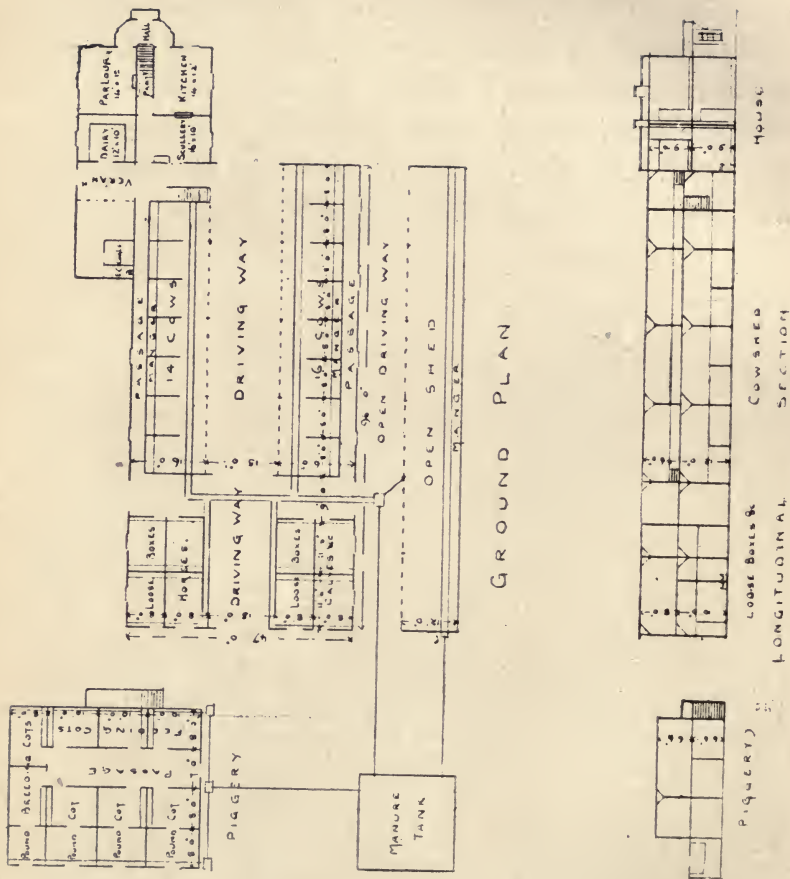
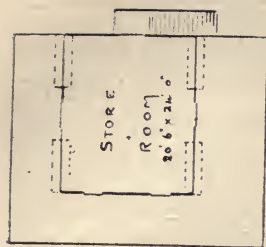
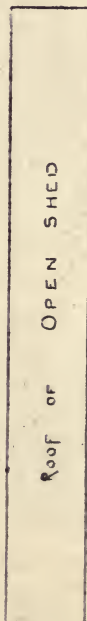
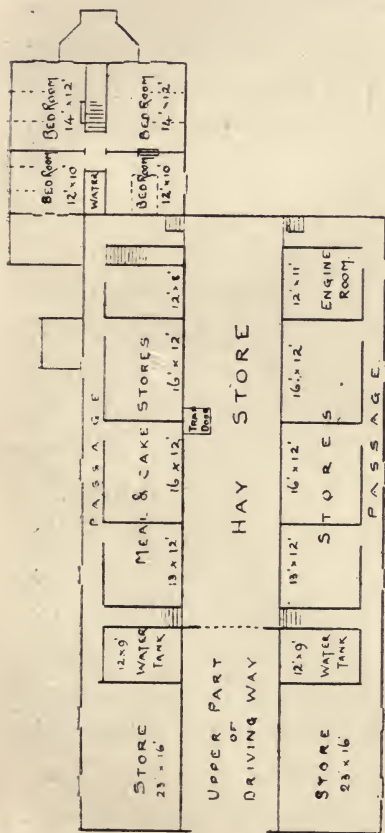

Fig. 20.



UPPER PART
OF
PIGGERY.



FIRST FLOOR PLAN.



OPEN SHED
COWSHED
CROSS SECTION

Fig. 21.

A dairy herd of cattle cannot be fully covered by a fire insurance; the replacement of a herd of milking cows within a reasonable time is an almost impossible task, and with the great increase in the dairy industry necessitating new buildings, every reasonable provision for safety should be provided.

A plan of Cow Stalls is shown in fig. 19, and a Dairy Homestead on a Dutch model in figs. 20 and 21, compactness of design and easy working being the main points. This plan is evolved from a somewhat similar construction that is in working at present.

Very large sums of money are often wasted on farm buildings, but in most cases the want of good buildings is a serious handicap on good farming. The inconvenience of the scattered homestead renders nearly half the year a system of drudgery and waste, and in some cases the extra cost in actual labour would pay a high percentage on the cost of well-planned buildings.

Concrete for impervious floors renders available all liquid manure, and the collection of this important element is easily attained if the construction is compact.

RAT-PROOF GRANARY WITH REINFORCED CONCRETE BINS (fig. 24). The floor is 6'' thick and 12' span, reinforced by $\frac{1}{3}$ '' square indented bars placed 7'' apart, and bars of the same size every 18'' at right angles. It often carries a weight of



Fig. 22.—CONCRETE PILLARS.

The head of this pillar is made large to take a wide bearing, and thus save in the number of posts necessary to support the building. A section shows the reinforcement. The cost of this pillar was under 1*s.* per foot run. A rat-proof overhanging manger is shown in the photograph.

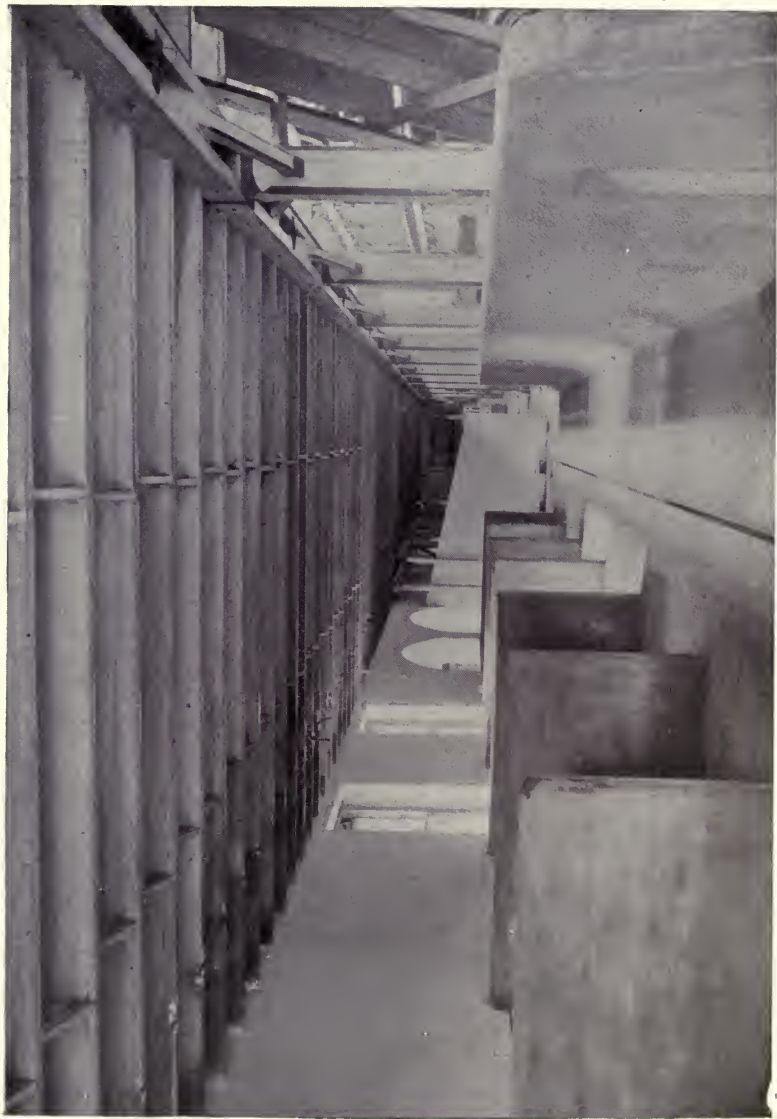

Fig. 23.—CONCRETE COW STALLS : WINNINGS FARM, COLWALL.

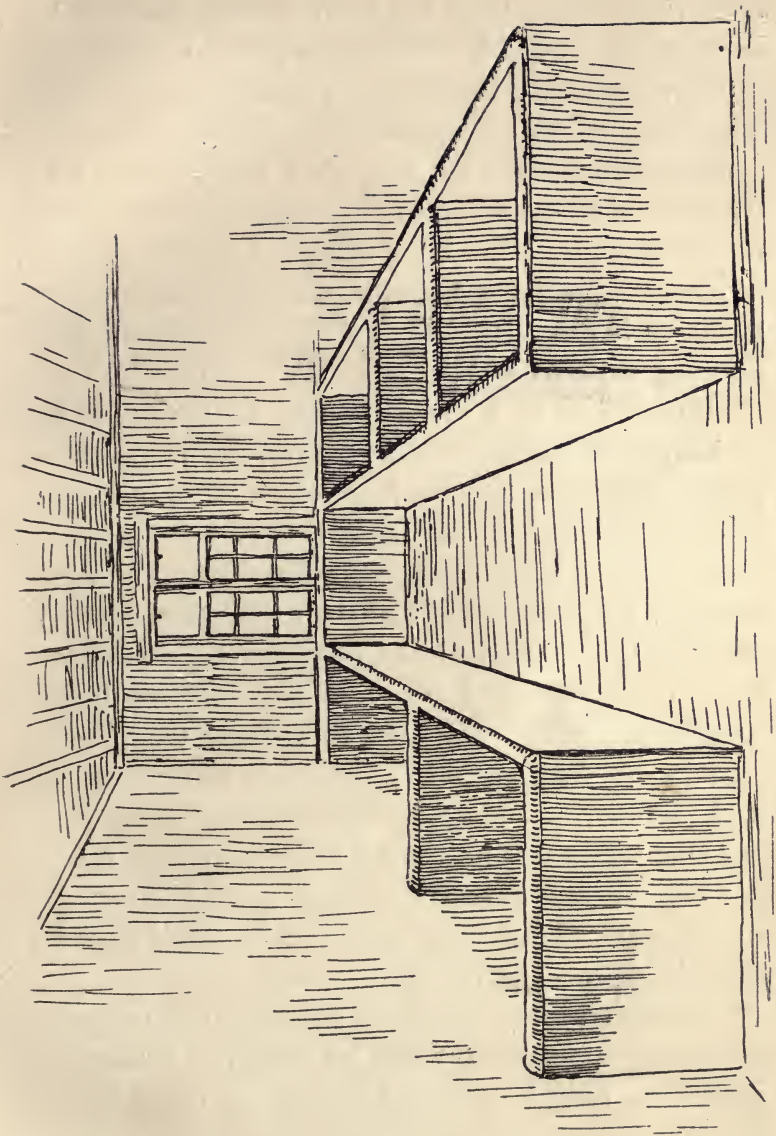

Fig. 24.—RAT-PROOF GRANARY.

CONCRETE FOR HOUSE, FARM, AND ESTATE.

over eight tons. This has been a most successful excluder of rats. A full-sized rat with a free run to corn cannot be kept for less than 1s. per week. The cost of this construction was 3*l.* 10s. per square, namely, 10' by 10'. No farm should be without a rat-proof granary, even if the cost is much in excess of the sum stated. Fig. 52 (at end of book) shows the under-side of granary floor with beam and rings in floor (above loose box) for slinging a horse.

HOW TO MAKE A MANGER (figs. 25, 26, and 27).—A concrete manger can be strong, clean, and rat-proof. The supports, or foundation, of a manger may be in concrete or brickwork, and should be erected to the desired height for the bottom of the manger; boards strutted will then support concrete to form the bottom of the manger, the thickness being 3'', and should be reinforced by two bars running longways and cross-bars every 9''. Side planking is then placed in position, the concrete well rammed in and vertically reinforced every 9'', together with three horizontal bars, one placed near the top of the manger. Rings can be inserted where required by being attached to small hooks embedded into the concrete.

The aggregate should be strong—four or five to one of cement. It will be observed that the whole of the boards and planking can be of ordinary square-cut timber.

The inside struts and boards should be removed.

in about twelve hours, and the edges rounded off by good cement plaster. The inside edge may be turned over to any extent that may be required. The operation of finishing off the manger and

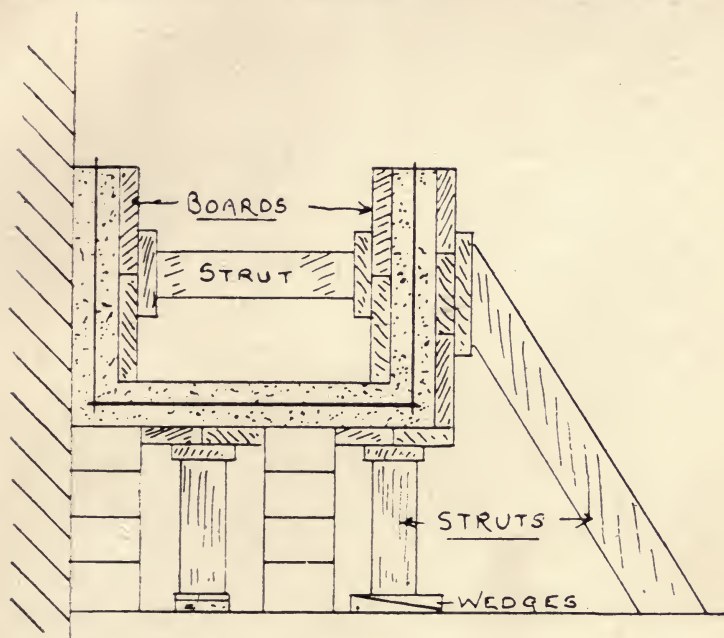

SECTION OF MANGER
SHOWING NECESSARY WOOD
STRUTTING FOR CONSTRUCTION.

Fig. 25.

taking out the angles must be done before the sides are set hard; the inner boards removed, while the outside boards remain to support the wall until set (see section, fig. 26). Any portion of the manger can be divided off for a drinking-

place; but, as a rule, a drinking-place is better at a level above the manger.

In a long manger, cross-bars or divisions every 4' not only give additional strength, but make sec-

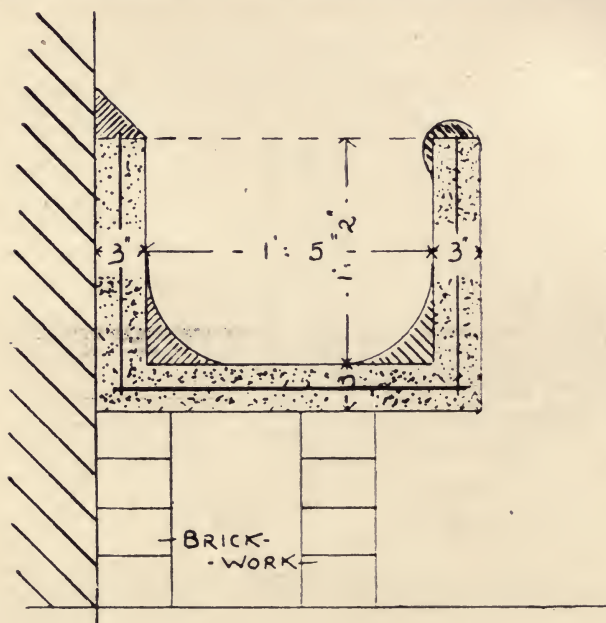

SECTION OF MANGER
SHOWING SHADED PORTIONS
FILLED IN BEFORE CONCRETE HAS SET

Fig. 26.

tions that are generally wanted. These bars can be inserted by a three-sided box 3'' deep and 3'' wide, filled from the top, and propped from the bottom of the manger. The sides of the manger

CONCRETE FOR HOUSE, FARM, AND ESTATE.

should be cut down 3'' against a vertical bar of reinforcement in which position the box is placed. One bar for reinforcement $\frac{1}{3}$ '' square and turned down at each end will give ample strength. About

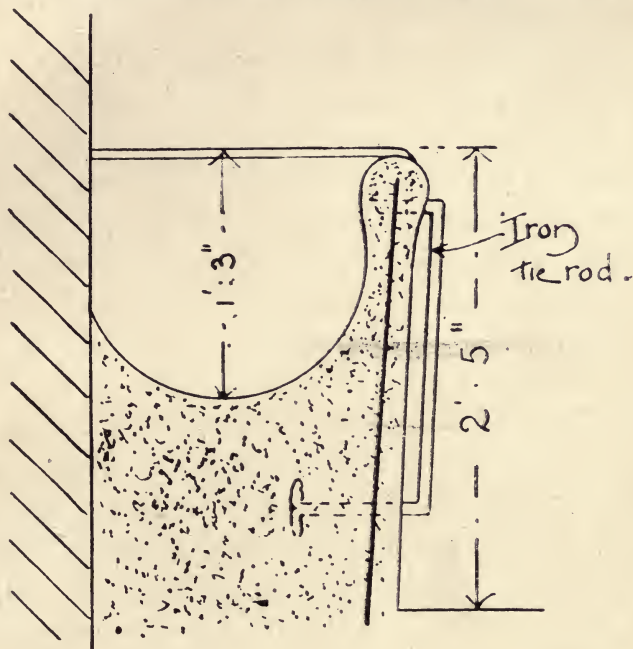

SECTION OF BULL MANGER.

Fig. 27.—A Bull's Manger of solid concrete, and made to stand against a bull of over a ton weight.

one-third of the manger may overhang the vertical supports; this will render it rat-proof from the floor.

The detailed description given of mangers is somewhat lengthy—it is hoped it may be easily

followed as the construction is of such a useful character, and the cost in almost any district will compare favourably with any other kind of manger; 1s. per foot run would often more than cover the expense.

DOOR AND PARTITION (see fig. 28).—This construction shows concrete used to advantage in a tight corner. On the right hand is a post against a concave stone wall, a difficult place to fit a wood post and partition neatly. The partition is in front of a dairy, the yard being constantly washed; the posts are wet and dry daily, yet with no damage or depreciation such as would be the case with timber posts. No wood is in contact with the ground.

CULVERTS AND PIPE COVERINGS (fig. 30).—The question of conveying water under a roadway, with the difficulty of not getting the outlet too deep, and at the same time providing for modern engine traffic, is a problem repeatedly met with. A section shows a useful-sized culvert. The concrete base should be taken to firm ground. Reinforcement in the base may not be necessary. The top covering can be made in slabs 18" long, and put in position as soon as the brickwork is ready to receive it. These slabs should be reinforced with $\frac{1}{2}$ " square bars every 7" across, and three bars placed longitudinally. The slab in some cases may with advantage be 4" or 5" thick. Care should be taken to consolidate the material

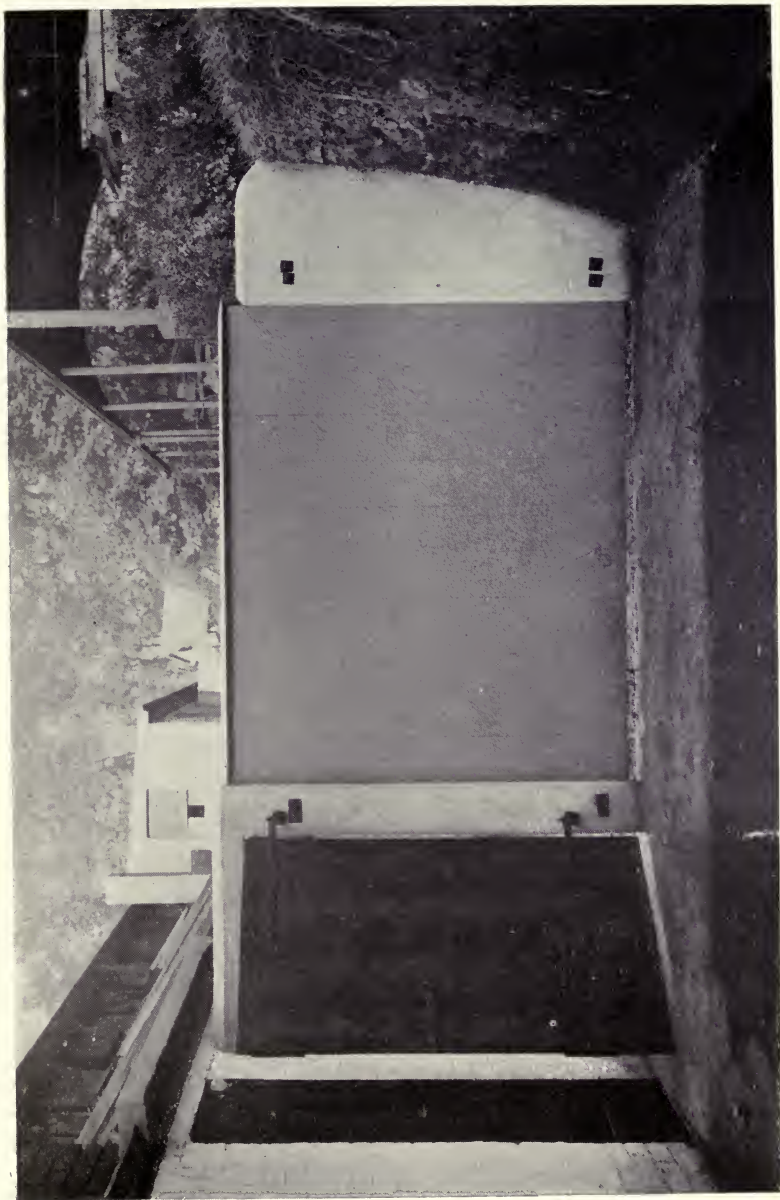

Fig. 28.—Door and Partition.



Fig. 29.—BULL'S HOUSE.

CONCRETE FOR HOUSE, FARM, AND ESTATE.

on the outside of the walls after the slabs are put on, and if rammed hard to the level of the top of the slab, and then watered and left for a time, a further consolidation will take place, and material can then be filled in to the ground-level.

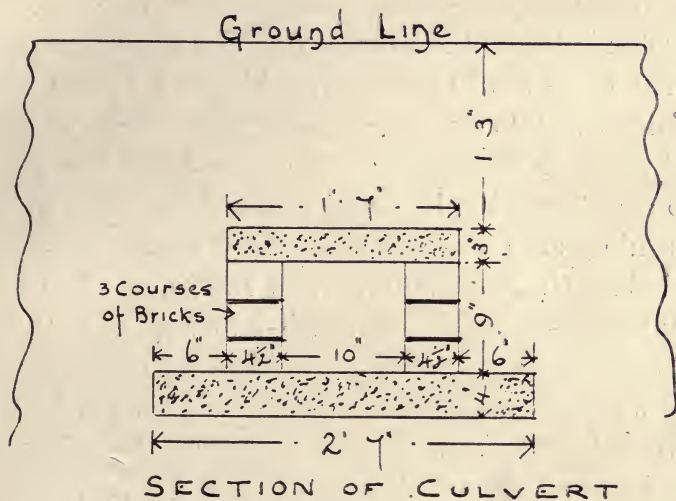

Fig. 30.

A BULL'S HOUSE (fig. 29), with wall 6" thick, replacing an 18" wall. The shutters fit in openings without any wood framework; they are hinged inside by bolts through the wall, and can be readily renewed. The gatepost supports a very heavy yard door: it has been in perfect alignment ever since its erection some years ago, and the treatment by stock and workmen is often very rough. It will be seen that the position would be an awkward one for wood post.

GATEPOSTS.

Concrete posts made in position are always the best (see fig. 33), but they can be made and carted to where they are required, in which case the reinforcement, consisting of one or more bars, should protrude beyond the bottom of the post—the post then being set in concrete. A base 4' square and 1' deep will do for a heavy gate. The main portion of the base should be on the off side of the gate, to counteract the leverage of the gate. The holes for hinges are made by taper wood plugs.

STABLE EXTENSION.—The extension of an old building—a stable or coach-house (fig. 31) for instance—may often be troublesome on account of want of head-room. A gutter is always to be avoided, especially in the country, where leaves find harbour, and clumsy feet, or a sharp-edged shovel, will in a few moments do heavy damage to lead or slates. A lead flat in ordinary work is prohibitive on account of its cost; it necessitates timber and plumbing, and will probably take more space than a concrete roof. The illustration shows wall and roof of a 2' 6'' extension on a stable, all in concrete.

GATEPOST AND STILE.—A short length of fencing in wire or pale always lacks the endurance and strength of longer lengths of fencing. Positions of this character will often repay for the construction of a concrete wall. If a wooden gatepost is



Fig. 31.—STABLE EXTENSION.

Face page 40.



Fig. 32.—GATEPOST AND STILE.

CONCRETE FOR HOUSE, FARM, AND ESTATE.

combined with a stile, the probability of getting out of order is increased.

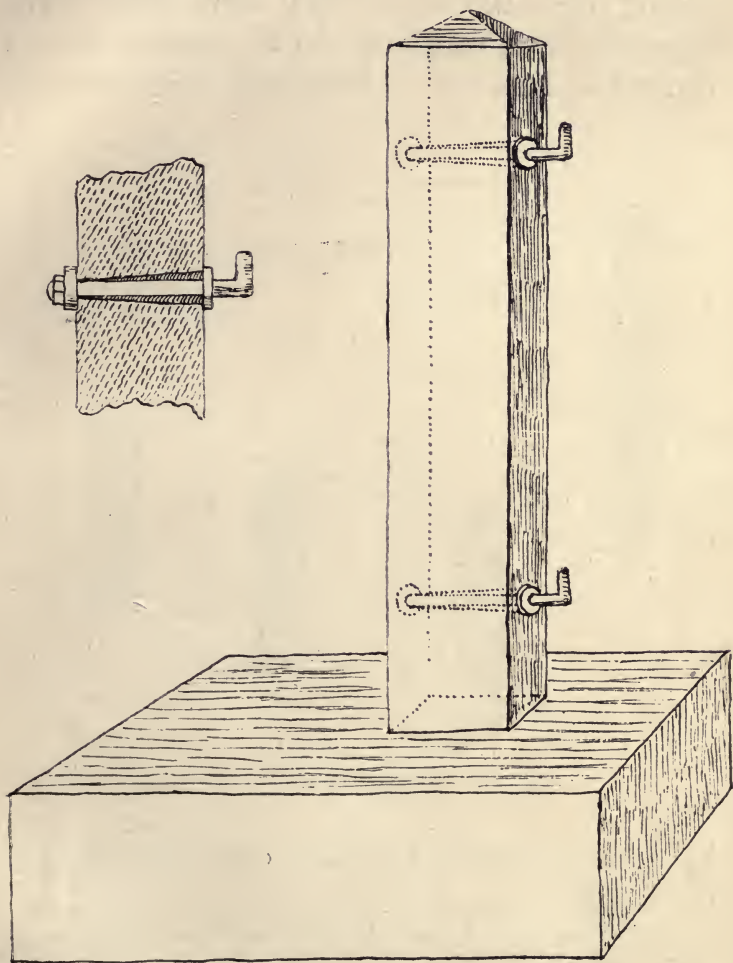

Fig. 33.—SECTION OF GATEPOST.

Fig. 32 shows a concrete wall 5'' thick, the gatepost constructed at the same time and rein-

forced into the wall. The sketch (fig. 34) shows how the wall is supported on piers, thus economising material on a bad foundation. The aggregate was made of one of cement to two of sand and five of $\frac{3}{4}$ " chippings, and reinforced

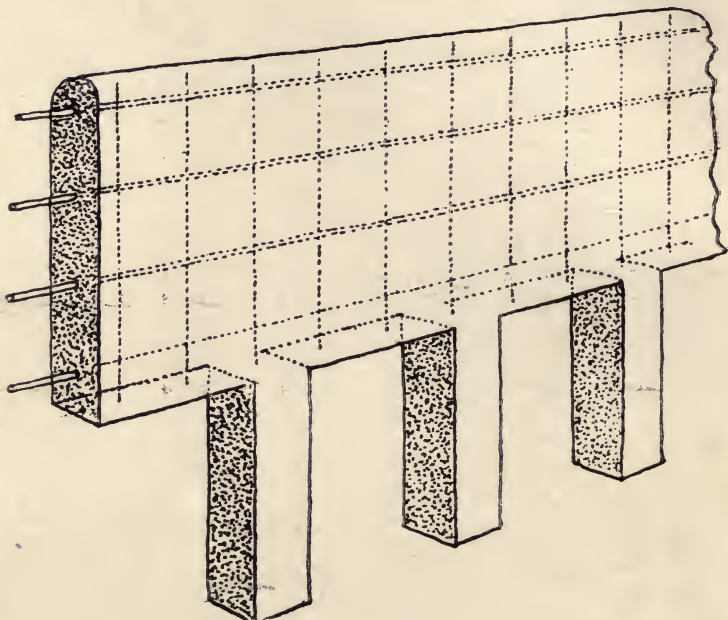

Fig. 34.—PIERS TO SOLID FOUNDATION.

by $\frac{1}{3}$ " square bars 9" apart vertically and 18" horizontally.

The coping shown in fig. 35 was put on *in situ* after erection of wall. A continuous concrete coping is very superior to the best brick coping, as it leaves no joints to get out of order. In almost any part of the country the cost of a con-

CONCRETE FOR HOUSE, FARM, AND ESTATE.

crete coping would be much less than the cost of a blue-brick coping. The shape on top can be varied to suit any taste, but with a garden wall it is best to have the drip outside.

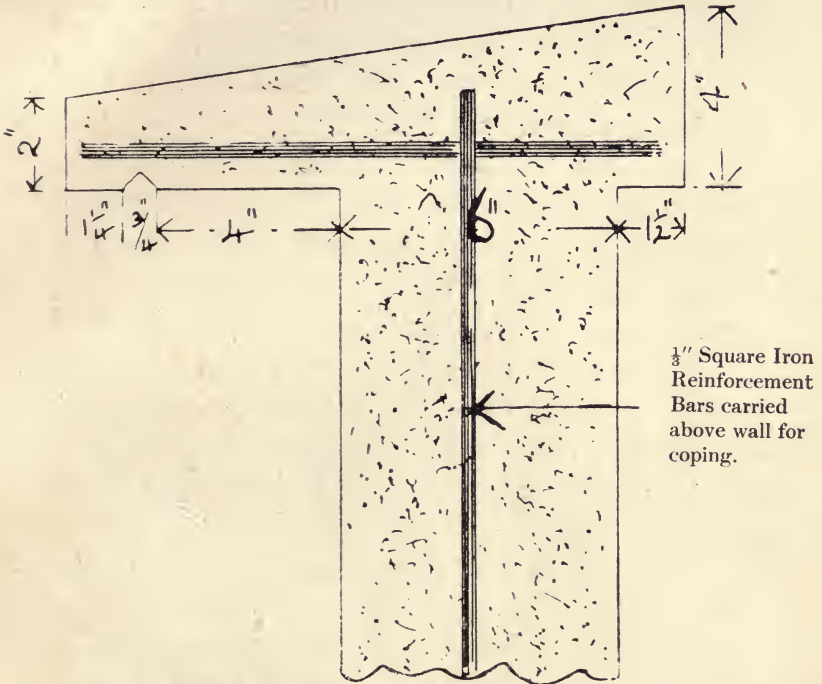

Fig. 35.

DITCHES.

On many farms an enormous lot of land is lost by cattle breaking down the sides of ditches and often diverting the water, to the further destruction of the land. Figs. 36 and 37 show a stone ditch constructed over forty years ago. The only repairs that have been necessary have been effected by a

CONCRETE FOR HOUSE, FARM, AND ESTATE.

concrete edging on the top side of the ditch, careless cleaning and heavy cattle having displaced some of the edging stones. The continuous concrete tie will probably give at least another forty years' life to this construction. It will be seen that sound grazing-land runs right up to the edge of the ditch; in a few places the turf has been turned back to show the concrete (fig. 37). The actual cost of this ditch construction is not an expensive affair in a district where stone is available, and not only does it mean a saving of land, but it reduces the cost of cleaning when compared with the usual dirty ditch. The construction, of course, may be entirely in concrete: especially in a case of lengthy haulage of material the reduced bulk might favour concrete, and it would certainly make a better job than stone.

CONCRETE WALL AND HEAD (fig. 40).—This construction was erected in an open fold-yard for feeding cattle under, and shows a form of roofing with the single wall as a support; a roll of concrete is put along the outside edges, and the roof pitches slightly to the one end where the water is required to run off. A much larger span could be covered with perfect safety, and in exposed districts would form a cheap and durable shelter for sheep or cattle.

CONCRETE DRINKING TANK FOR CATTLE (fig. 38).—The construction of a tank of this

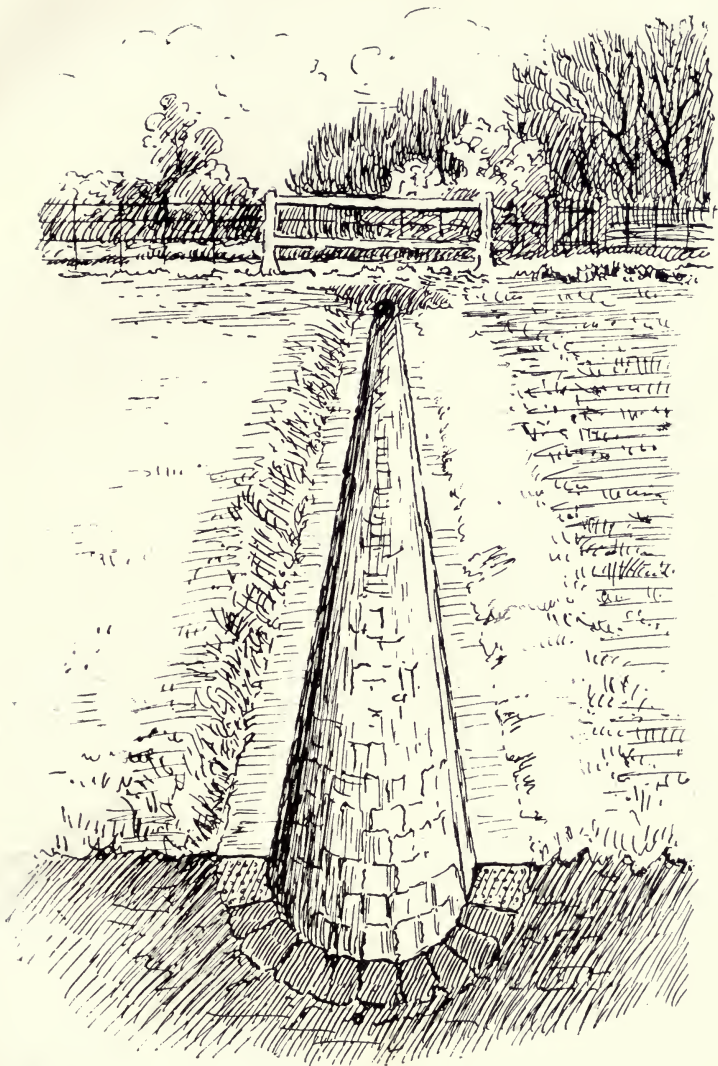

Fig. 36.



Fig. 37.—STONE DITCH EDGED WITH CONCRETE.

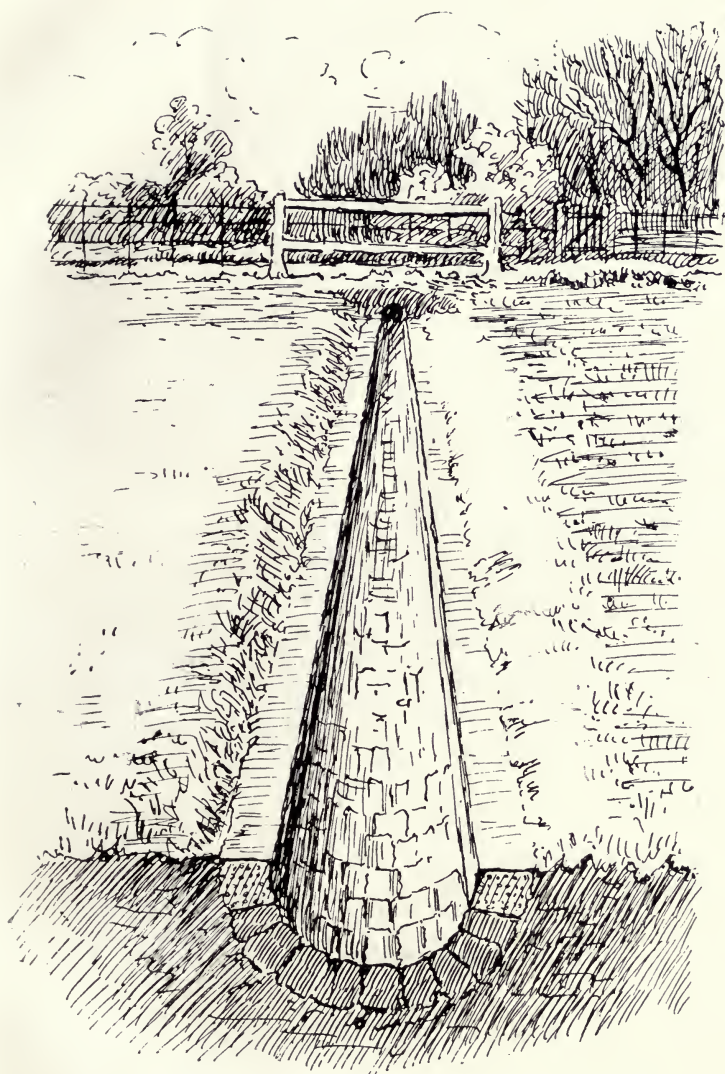

Fig. 36.



Fig. 37.—STONE DITCH EDGED WITH CONCRETE.



Fig. 39.—TAR TANK AT COLWALL GASWORKS.

This tank holds 2000 gallons. It is built above ground level for barrel-filling, one end supported on brackets owing to tar-well being underneath. Cost 18*l.*, including builder's profit.



Fig. 38.—CONCRETE DRINKING TANK.

kind is very much on the same plan as a concrete manger, described on pages 34 to 37.

APPLE STORE.—The English apple, king of all fruits, has much too short a season. The keeping of good fruit can be extended from one season to another by careful storage. The perspective sketch (fig. 41) shows an apple store. The concrete roof

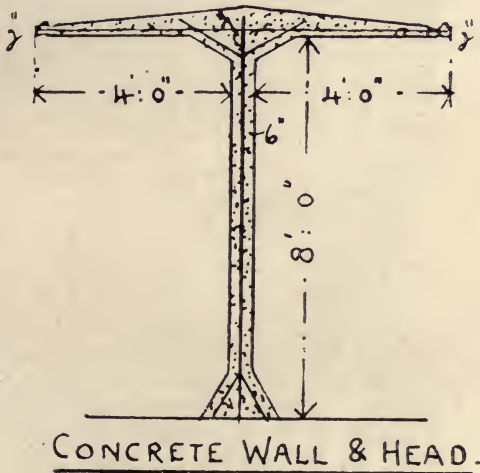

Fig. 40.

keeps the temperature even. The store is better if partly underground, ventilation in the autumn being provided by air bricks and lattice doors.

SUNKEN CATCH.

Fig. 42 shows end of wall rebated for latch-catch. The door shuts flush with the wall, leaving no dangerous obstruction to injure cattle. The

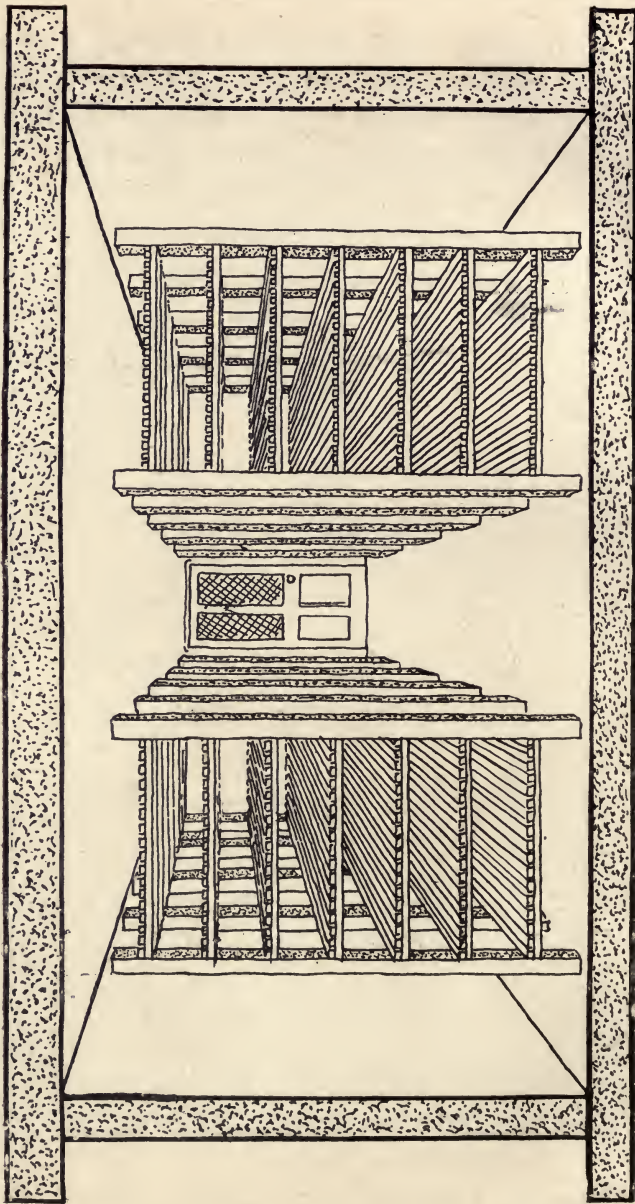

Fig. 41.—APPLE STORE.

wall being 5'' thick and well reinforced, is amply strong enough to receive a 1½'' door. On the corresponding wall the door is hung. Wood plugs are inserted through the wall during construction

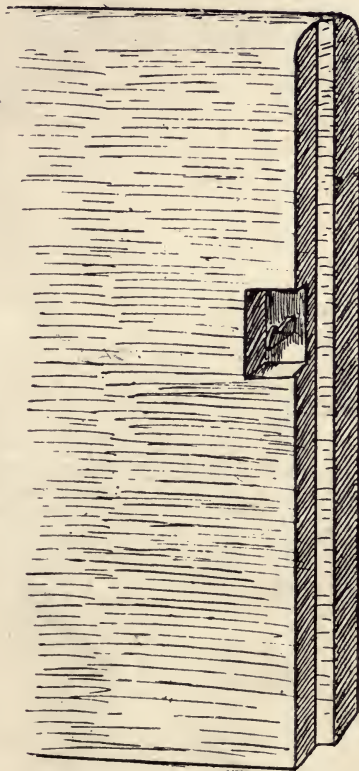

Fig. 42.—WALL AND LATCH-CATCH.

for catch and hinges, which are fixed on the inside by screw nuts. The hole for the catch is made by putting in a block of wood; this, like the plugs, needs a slight taper for easy removal when the

planks come down. The wall will need very little foundation if the floor is concrete, and care is taken to reinforce the wall to the floor. The

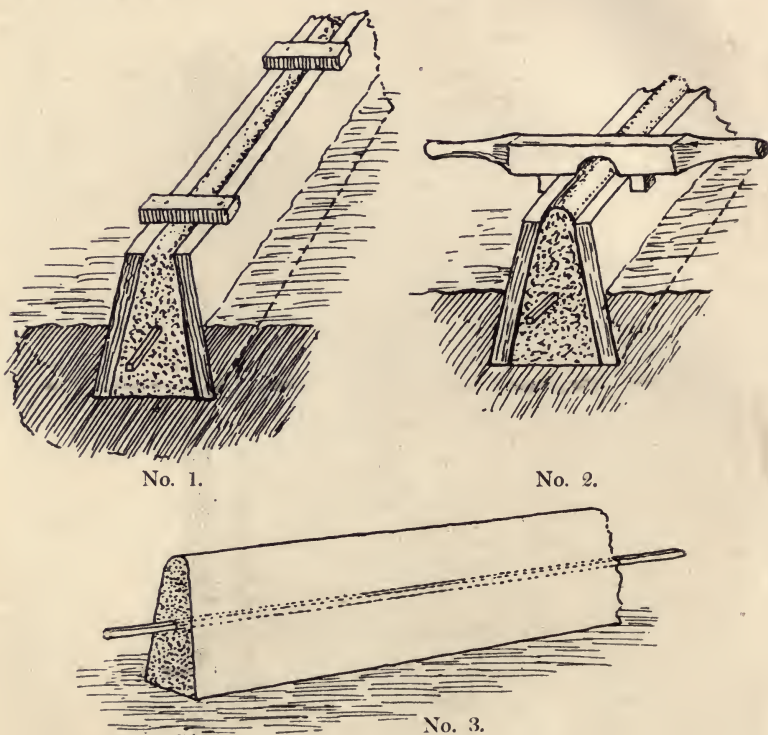

Fig. 43.—GARDEN KERB.

saving of cost over wood posts is a great advantage.

GARDEN KERB.

Fig. 43 shows a garden kerb 9'' deep, 4'' wide at base, and 2'' on the top. No. 1 shows boards



Fig. 44.—House designed by Fred and Beatrice Ballard. Built at Colwall for Miss Kissel.
Concrete roof on brick walls.



Fig. 45.—House built with brick, covered with cement plaster. Floors and roof of reinforced concrete. $\frac{1}{8}$ " square indented bar used in spans up to 15'. The bay windows extend 4' beyond the perpendicular of the walls. Designed and built by F. and B. Ballard in 1909.



Fig. 46.—CONCRETE PORCH.

A plain and strong construction designed for climbing roses, and will eventually form a bower. The whole structure may be completely covered by vegetation without doing the least injury to the building.



Fig. 47.—AN ANGLE WINDOW.

It is economical and easy in construction when compared with any other form of building in a like position.



Fig. 48.—A Bungalow, the walls of which are all solid concrete 5" thick. A considerable quantity of barbed wire was used in reinforcing this building. Designed and constructed by Fred Ballard in 1904.



Fig. 49.—PORCH AND OBSERVATION WINDOW ON ANGLE.

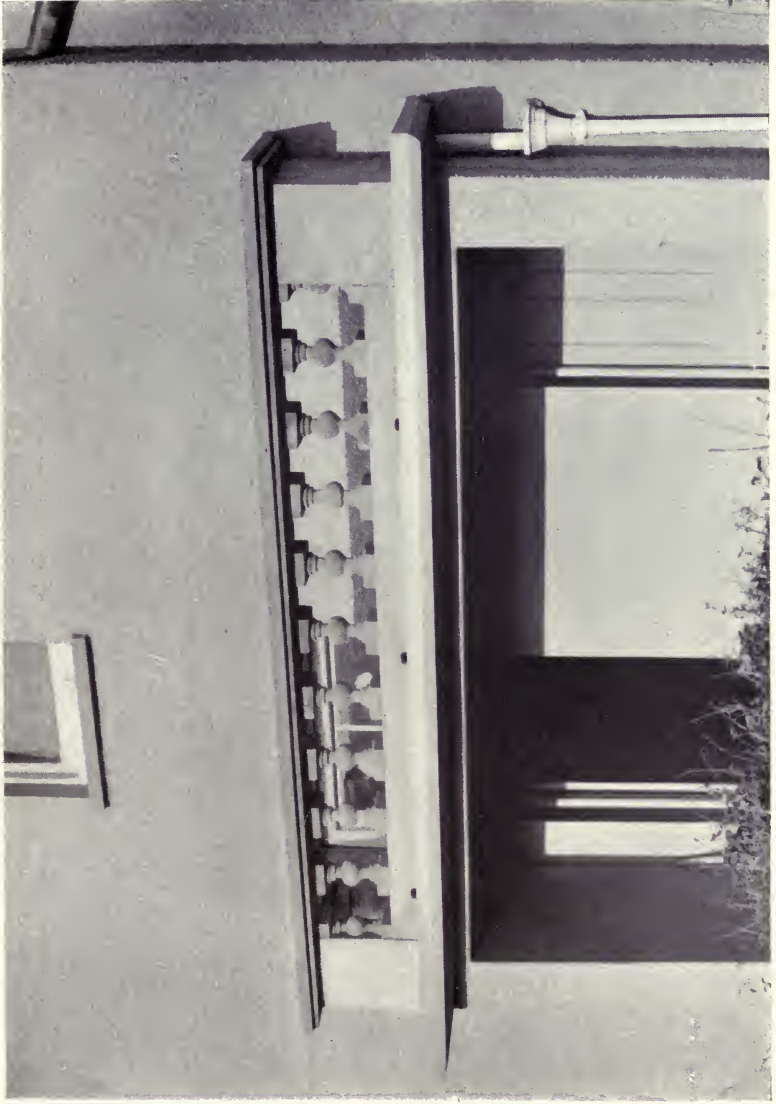
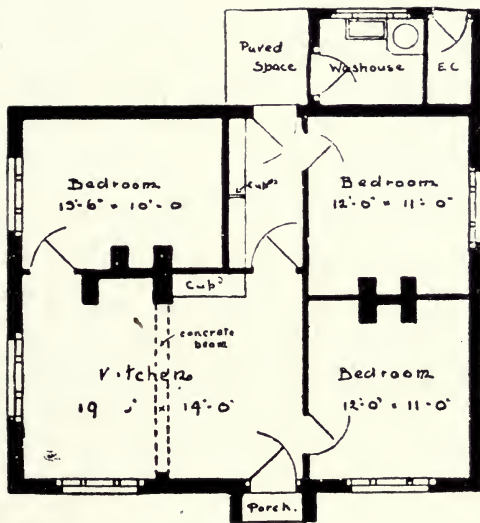

Fig. 50.—BALCONY BETWEEN TWO DOORS (10-foot span).



Fig. 51.—LABOURER'S COTTAGE ERECTED AT COLWALL FOR £160.
(Brick cavity walls and concrete roof.)



GROUND FLOOR

Ground Plan of fig. 51 (opposite).



Fig. 52.

CONCRETE FOR HOUSE, FARM, AND ESTATE.

set partly in the earth and filled with rammed concrete. No. 2 shows gauged strips taken off top of boards, a little extra filling being put on and struck round by a wooden gauge. No. 3 is a finished kerb, with single bar for reinforcement showing. No difficulty will be experienced in digging right up to this kerb; unlike edging tiles, it retains its position.

Greaves, Bull, & Lakin, Ltd.



Manufacturers of Best Portland Cement

SPECIALITIES :

FINE GRINDING.
FREEDOM FROM EXPANSION.
STRENGTH.
UNIFORMITY
COLOUR.

**Quick, Medium, or Slow Setting
as required.**

Head Offices: HARBURY, LEAMINGTON.	Greaves' Cement	Works:
Telegrams: GREAVES, HARBURY.	WAS USED EXTENSIVELY BY THE AUTHOR OF THIS BOOK.	HARBURY. STOCKTON. ETTINGTON. WARWICKSHIRE.
Telephone: 7 SOUTHAM.		

Also
Blue Lias Lime and Selenitic Plaster.

WILLIAM PEARCE,

**1-12 Bridge Street, Broad Street,
BIRMINGHAM.**

**GLASS AND LEAD MERCHANTS
AND MANUFACTURERS.**

General Builders' & Plumbers' Merchants

Glass Benders.	Brasswork of every description.
Glass Bevellers.	Rainwater Pipes and Gutters.
Glass Embossers.	Builders' Ironmongery.
Glass Silverers.	Tubes for Gas, Water, and Steam.
Looking-Glass Manufacturers.	Paints, Oils, & Varnishes,
Baths.	Painters' Brushes.
Grates of every description.	Paper Hangings.
Ranges.	Sanitary Fittings of all kinds.
Lavatory Basins and Closets.	

**Artists in Ecclesiastical & Domestic Stained Glass.
Metal Casement Manufacturers.**

RANSOME

Hand & Power Mixers



FOR FARM AND ESTATE WORK.

STRONGER CONCRETE AT LESS COST.

SAVING IN CEMENT.

PARTICULARLY SUITABLE for CONCRETE BLOCK WORK.

Catalogues and Estimates from

RANSOME-VERMEHR MACHINERY CO., LTD.

Telegrams:
Vermehrico,
London.

2 CENTRAL BUILDINGS,
WESTMINSTER, S.W. 1.

Telephones:
2188 }
2189 } Victoria.

THE
LIMMER ASPHALTE PAVING Co.

CHIEF OFFICE :

LTD.

CAXTON HOUSE, WESTMINSTER, LONDON, S.W.

LIMMER, MONTROTIER SEYSSEL, and

LES TATES SEYSSEL MASTIC

ASPHALTES

for

Horizontal and Vertical Damp-courses,

Roofing, Flooring, &c.

LITHOFALT PAVING BLOCKS

FOR COURTYARDS, STABLES, AND

WAREHOUSE FLOORS, &c.

FREEHOLD MONTROTIER SEYSSEL MINES,

LOVAGNY (*HAUTE SAVOIE*), FRANCE.

Local Branch Office :

122 Colmore Row, Birmingham.

Sheldon Concrete Mixer

'Takes the Backache out of Concrete.'

Suitable for

COW HOUSES,
STABLES,
CRIBS,
FLOORS,
FOUNDATIONS,
WALLS,
BUILDINGS,
FENCES,
WALKS,
CULVERTS,
STEPS,
PITS,
BRICKS, &c. &c.



PAYS for itself on Your First Small Job.

SAVES the Labour of One to Three Men.

DOES as Good Work as Any Mixer Made.

JUST the Mixer for Use in Farm, Small City, or Town Concreting Construction Work.

It is just the right height to handily shovel the aggregate into the barrel.

It is just the right angle to see how the mixing is being done.

You don't have to stoop.

You don't have to stretch.

THE 'SHELDON' is a boon to every one having concreting work to do. Let it be of help to you.

THINK of the Special Tilting Arrangement which permits the concrete to be dumped right into your barrow.

Write for our booklet on 'Concrete Mixers,' hand and power machines.

PARKER, WINDER & ACHURCH, Ltd.,

Broad Street & New Street, BIRMINGHAM.

Telegrams : IRONCLAD.

Telephone : MIDLAND 41.

UNIVERSITY OF CALIFORNIA LIBRARY
BERKELEY

Return to desk from which borrowed.
This book is DUE on the last date stamped below.

8Jan5 2WKA

20Dec'51LU

YC 68195

M323074

