

# CONCRETE SILOS

195  
7  
14  
ppy 1



UNIVERSAL PORTLAND CEMENT CO.



---

# Concrete Silos

A Booklet of Practical Information  
for the Farmer  
and the Rural  
Contractor

---

PREPARED BY THE INFORMATION BUREAU  
UNIVERSAL PORTLAND CEMENT CO.

11

PRICE 25 CENTS



PUBLISHED BY THE

## Universal Portland Cement Co.

CHICAGO — PITTSBURGH — MINNEAPOLIS

*SEVENTH EDITION, 1914*

*Copyright 1914, by Universal Portland Cement Co.*

*6-15-14-50M-D*

SB195  
U7  
1914

## Harder Patent Does Not Cover Concrete Silos

For the information of parties planning the erection of concrete silos, we quote the following from the opinion of our patent counsel relative to the Harder patent No. 627732.

"The Harder patent as interpreted by Judge Ray is limited to a silo having a continuous opening from top to bottom, a series of sliding doors, reinforcing strips and braces of peculiar form. The court said in its opinion, 'It is obvious that the braces of the Harder patent would be superfluous in stone or brick silos'; this being true, the Harder improvement would be wholly unnecessary in silos made of concrete.

Therefore we advise you that the Harder patent does not cover all forms of silos; that it is limited and restricted to substantially the exact construction which it shows and describes and that it is unnecessary, if not undesirable, in silos made of concrete."

Since concrete silos are not covered by the Harder patent, farmers and contractors need have no hesitancy in building silos of concrete and are requested to advise the Universal Portland Cement Co. of cases where any claim of an infringement is made.

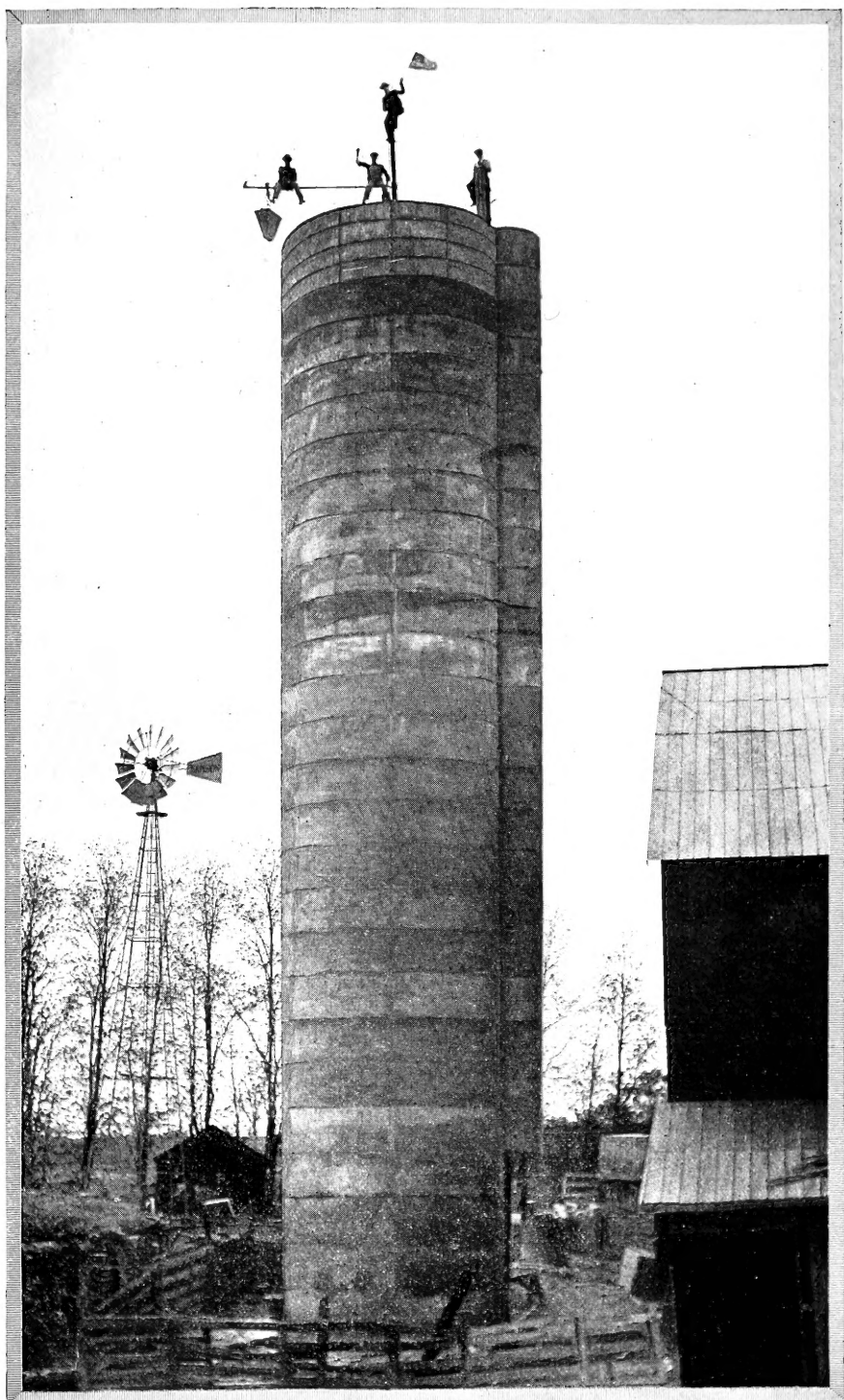

Tallest Silo in the World—93 Feet High—built of concrete. Contractor, H. B. Collom, Somerville, Ohio.

# Table of Contents

## *Silos and Silage*

General Facts:	Page
Advantages of Silos . . . . .	7
Brief History of Silos . . . . .	8
What Leading Farm Papers Say . . . . .	11
Common Silo Superstitions Exploded . . . . .	19
Silage for Beef Cattle . . . . .	23
Silage for Dairy Cows . . . . .	28
Silage for Sheep, Horses and other Live Stock . . . . .	30
Silage Crops . . . . .	35

### General Information on Silos and Silage

Capacity for a Given Number of Cattle (Example) . . . . .	37
Table of Capacities of Round Silos in Tons . . . . .	36
Economical Diameter . . . . .	37
Height . . . . .	37
Location . . . . .	38

### Filling the Silo—Using Off Silage:

When to Harvest Corn for Silage . . . . .	38
The Cutter . . . . .	39
Elevating and Distributing . . . . .	39
Economy of Filling the Silo Rapidly . . . . .	40
Wetting the Silage . . . . .	40
Cost of Filling . . . . .	40
Table Showing the Cost of Filling Fifty-nine Concrete Silos . . . . .	102
Cost of Silage . . . . .	42
Using Off the Silage . . . . .	42

### Advantages of Concrete as a Silo Material:

Fireproof Construction . . . . .	46
George Pulling's Silo . . . . .	46
A. B. Main's Silo . . . . .	47
The Element of Waste . . . . .	48
The Effect of Freezing . . . . .	49
Concrete Silos Successful in Coldest Climates . . . . .	50
Concrete Roof Prevents Silage Freezing . . . . .	50
Time Required to Build a Concrete Silo . . . . .	50
A Comparison of the Monolithic and Concrete Block Types . . . . .	50

## *Building the Silo*

### Methods of Building:

Contract Work . . . . .	52
Work Under Hired Foremen . . . . .	52
Work Under Home Supervision . . . . .	53
Co-operation in Silo Work . . . . .	53

	Page
Foundations . . . . .	54
Home-made Form for Monolithic Silos . . . . .	56
Doorways . . . . .	63
Constructing Monolithic Silo Walls . . . . .	66
Building Concrete Block Silos . . . . .	74
Home-made Blocks . . . . .	78
Concrete Chutes . . . . .	80
Water Supply Tanks . . . . .	82
Concrete Roofs . . . . .	87

### ***Commercial Silo Systems***

Monolithic . . . . .	92
Concrete Block . . . . .	97

### ***Appendix***

Tables:		
	Triangle mesh reinforcement for monolithic silos . . . . .	100
	Cost of filling concrete silos . . . . .	102
	Free U. S. Government and State Experiment Station Bulletins on Silos and Silage . . . . .	104

### ***Index to Tables***

Title	Page
Capacity of Round Silos in Tons . . . . .	36
Quantity of Silage Required for the Dairy Herd and Economical Diameter of the Silo . . . . .	37
Cost of Filling 59 Concrete Silos . . . . .	102
Materials for Silo Footings and Floors . . . . .	55
Materials for Home-Made Silo Forms . . . . .	62
Cubic Yards of Concrete in Silo Walls . . . . .	67
Cement, Sand and Gravel Required for Monolithic Silo Walls . . . . .	68
Triangle Mesh Reinforcing for Monolithic Silo . . . . .	70-100
Size and Spacing of Reinforcing Rods in Monolithic Silo Walls . . . . .	72
Blocks Required for Walls of a Concrete Block Silo . . . . .	76
Size of Reinforcing Rods for Concrete Block Silo . . . . .	77
Capacities of Water Supply Tanks . . . . .	82
Materials and Reinforcing for Tank Floors . . . . .	84

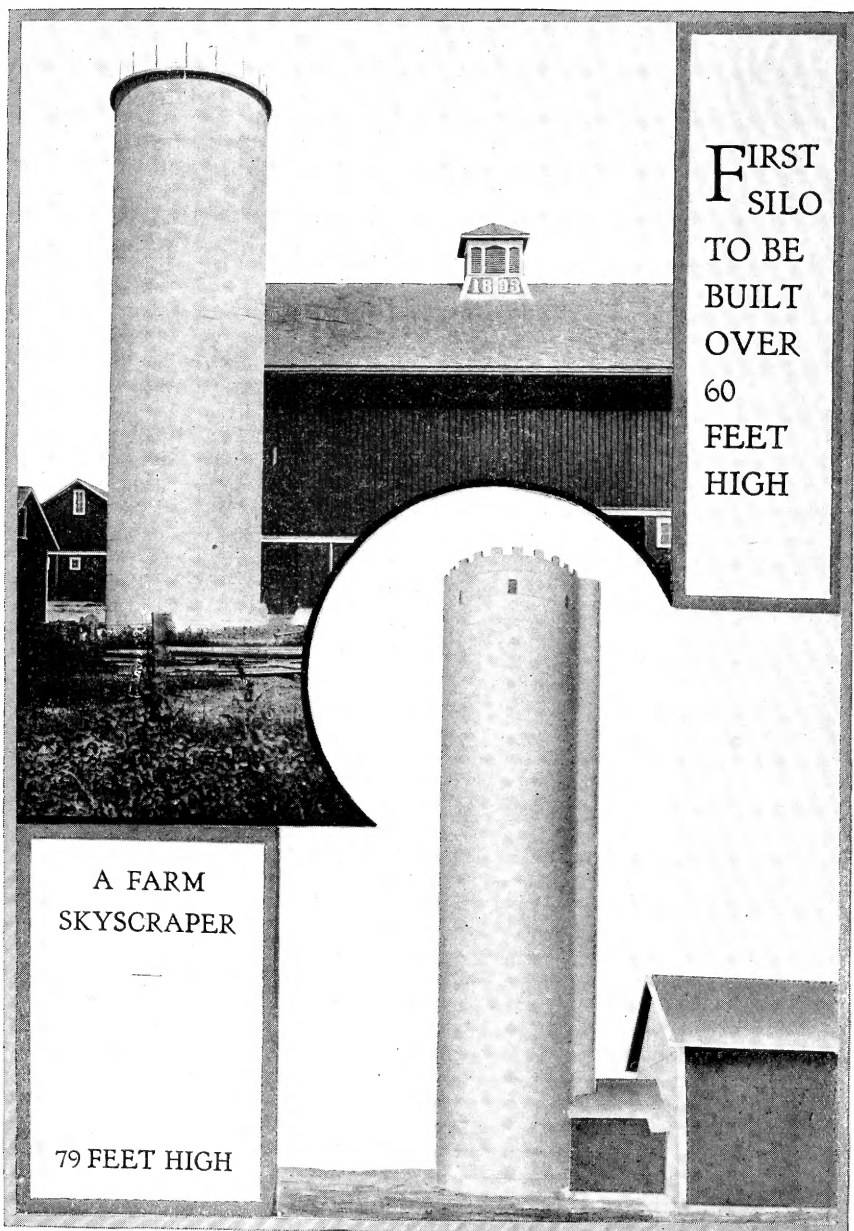

FIRST  
SILO  
TO BE  
BUILT  
OVER  
60  
FEET  
HIGH

A FARM  
SKYSCRAPER

79 FEET HIGH

Wilson Bros. Concrete Silo, Sugar Grove, Illinois.  
Inside dimensions 16x64 feet; built in 1912.  
Polk forms used. W. H. Warford, contractor.

Second Tallest Silo in the World. Built by H. B.  
Collom, Somerville, Ohio. Monsco forms used.  
Inside dimensions, 14x79 feet; built in 1913.



# Silos and Silage

## The Advantages of Silos

A silo on a farm is a mark of progress. No other building so well advertises the intent of the farmer to be progressive and up-to-date and no other building saves him so much money on the investment. The use of any reasonably good, comparatively air-tight silo pays. A good silo will pay as much as 100 per cent on the investment the first year. This is assuming, of course, that a reasonable number of cattle, horses, sheep or hogs are being fed. The silo saves all of the corn crop, 40 per cent of which would otherwise be wasted. In times of sudden rain, it frequently saves all the alfalfa crop which could be saved in no other manner except siloing it immediately. The silo eliminates troublesome corn stalks and elevates feeding, especially in winter, from back-breaking drudgery to a science. The silo is an asset: if built of permanent materials—it is a permanent asset.

The advantages of silos are almost too great to enumerate; in fact, almost any practical farmer who has built a silo finds a new reason which proves further its economy and necessity. No other building holds so much feed for such a small cost. To illustrate: A silo 60 feet high, 14 feet in inside diameter, will hold approximately 400 tons and such a silo has cost, all contractor's profits included, \$800. Where else could \$800 be invested in a building which would hold, safely and securely, proof against time, elements, fire, and vermin (for this was a substantial reinforced concrete silo with roof and chute), 400 tons of green, succulent fodder, and keep it not only two or three months but, if necessary, for two or three years? No other building but the silo will house so much for so little cost. This fact bankers as well as farmers should remember. Nowhere else is there so safe a loan which will do as much ultimate good to the community. When the banker loans a farmer money to build a silo, of a permanent material, such as concrete, the money will be invested in a valuable improvement, immediately increasing the value of the property.

A silo, nowadays, is used sometimes more in summer than in winter. There is no reason why a certain amount of silage cannot be fed successfully every day in the year; pastures, even in the most fertile parts of Illinois, Indiana, and Iowa, burned up one year under a rainfall in certain districts less than that of the Sahara Desert. At other times the fields are covered by floods, and blue grass or other pasture, however good, is destroyed. The early part of the year, 1913, when for nearly six months precipitation in Champaign County, Illinois, was less than  $1\frac{3}{4}$  inches, and the floods in the Ohio River Valley in the earlier part of that year where not only fields, but bridges and buildings were destroyed, should also be remembered.

The permanent silo, particularly, spells crop insurance. It makes

profits; it reduces costs; it saves feed; it conserves all the crop, particularly if that crop is corn. More than that, it conserves energy; it is efficient and reduces farm labor to a minimum.

But since, perhaps, the "proof of the pudding is in the eating thereof," and as few districts nowadays are without silos, the practical experience of neighbors should be sought. A little later on, extracts from some of the leading farm papers of the country touching on a number of disputed points are published. The careful reading of them, as they come from disinterested and authoritative sources, will prove the foregoing statements.

### Brief History of Silos

History tells us many things. It proves, apparently, that there is nothing new under the sun. The Egyptians, hundreds of years before Christ, put grain and other crops in large stone jars, covering them as tightly as they could. In the ancient ruins of Rome, similar jars have been found, made air-tight with a substance somewhat like bitumen. Julius Caesar, we are told, made pits at convenient points along the great military roads built by him, which were lined with clay, filled with green forage, tramped on and sealed with clay, so that he had food for his horses when the necessity pressed. Instances might be cited indefinitely, as of the Mound Builders and Incas in North and South America, who used jars similar to these of the Romans and ancient Egyptians and the

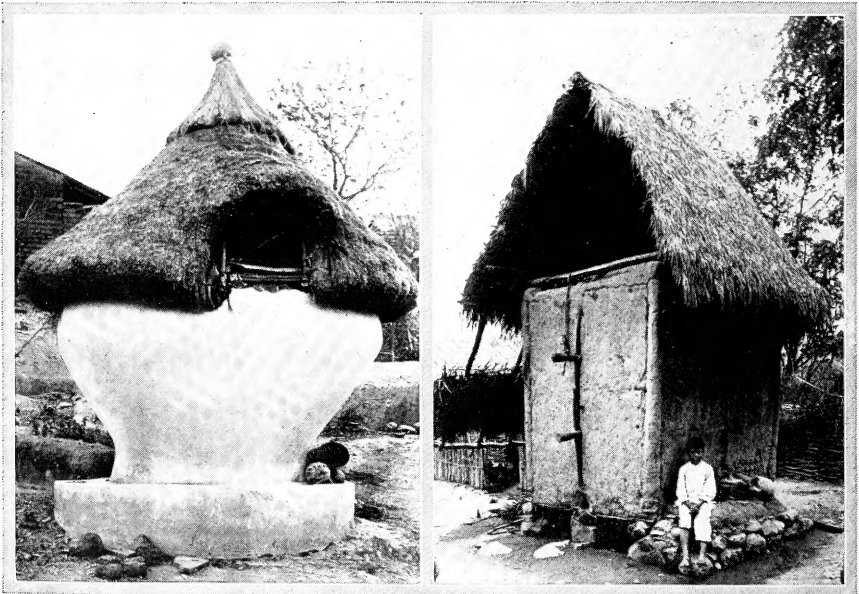

Mexican circular silo made of adobe, which successfully keeps green fodder in the drier parts of Mexico, where the material is not disintegrated by rain.

A less efficient silo than illustrated on the left. A square adobe silo; this type was first built in Mexico. Crude as they are, they are better than no silos.

Courtesy "Technical World."

same method as has been observed elsewhere. The silo is nothing more nor less than a large fruit jar.

In Africa the barbaric natives do not allow their crops to stand out in the fields at the mercy of the elements, but build a circular bin of interwoven reeds, plastered on both sides with clay, and covered with a thatched roof. When the fodder or grain is to be removed, the roof is propped up, for the time being, and replaced by the simple process of removing the props. These structures are from 3 to 6 feet in diameter and generally stand on stilts, with a total height of 6 to 12 feet.

In Mexico, for some time past, probably centuries, crude silos have been made of adobe, page 8. A square silo was first used, but the Mexicans, like other North Americans of a later date, discovered that the silage spoiled easily in the corners. Strictly speaking, their product is not silage as we understand it. It is a green fodder, packed in, but not cut into small pieces. Their next step in silo building and possibly the last for some time to come, was the round silo.

The silos shown on page 8 are crude structures, covered with thatch—which must harbor insects, rats and mice. Nevertheless, these are better than the methods, or lack of methods, used by many of the non-progressive farmers of to-day, who do not even take the precaution of covering their corn or machinery with a roof. The silos pictured in the illustrations show, at least, an intelligent effort on the part of the Mexicans to protect their food in dry seasons, and lead broad minded people to think that perhaps we might learn something from them.



Fifty-foot Concrete Silo put up for Ben. Searls near Picketts, Wisconsin, by George W. Western. Limberg molds used.

Another Concrete Silo with concrete chute—solid, substantial, and enduring—Limberg molds used.

It must be admitted that the savages of Africa and the half-civilized peons of Mexico use more care in protecting their fodder crops than many American farmers. More buildings of permanent material are needed on our American farms.

The twentieth century silo, par excellence, is undoubtedly the reinforced monolithic concrete silo. A well built, reinforced concrete silo with a concrete roof and a concrete chute is almost a defiance to nature. It defies time, fire, wind, sun, rain, frost action, and the alternate action of any or all of these elements combined. It is not injured by lightning. Concrete silos have stood unmoved against tornadoes and have successfully resisted shocks due to the impact of wagons, falling buildings and trees, and cannot be entered, undermined or affected by rats or other rodents, vermin or insects of any kind. The concrete silo cannot burn up; it will not blow down; it is a twentieth century structure because it represents more adequately than any other type of farm building the triumph of man over his natural adversaries and is a striking example of the victory of skill over brute strength or cunning.



Reinforced Concrete Grain Tanks, 16 feet by 65 feet inside dimensions. Built by Ed. Kuharske, Rockford, Illinois, for Spencer Otis, Sr., Barrington, Illinois. Car unloader shown on side.

## What Leading Farm Papers Say

### *Tremendous Silo Increase*

“It is claimed that the first silo in the United States was built in Michigan in 1875, but it was not until some years later that they came into any marked use, even in the best dairy districts. It is only within the last three or four years that their full practical and economic advantage was appreciated. The silo was generally regarded as simply a valuable adjunct to the dairy industry, and its appearance as part of the farm equipment indicated the presence of milch cows and a progressive dairyman. The value of silage in the production of milk was early appreciated, but it is only within four years past that its full economic value in all branches of the cattle industry began to be understood.

“Since 1910 experiment stations in most of the states of the central west have made repeated tests of silage as a feed for beef animals, as well as for breeding and for young animals. The results consistently show that such feed greatly reduces the cost of meat production, and increases the cattle carrying capacity of the farm. The constant advance in the price of farm land and the growing difficulty in profitably producing meat upon it, has centered general attention upon these silage feeding experiments. Knowledge of the favorable results quickly reached the feeding districts and has been acted upon. The increase in the number of silos in operation

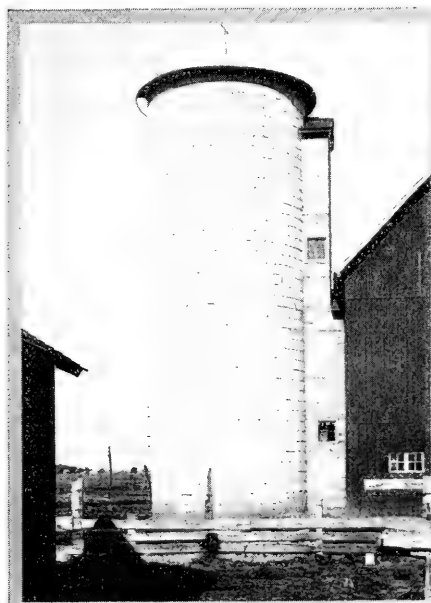

Homemade Concrete Block Silo on William Stall's farm near Lansing, Michigan.

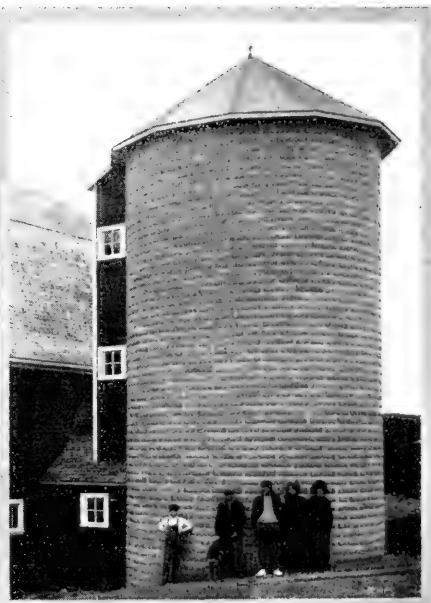

F. W. Merrill's Concrete Block Silo, built by owner, Kaneville, Illinois.

during the past two years is one of the most striking movements recorded in the history of American Agriculture. Within that time the number has more than doubled, and the movement appears to be just well under way.

### Estimated Number of Silos, January 1, 1914

	Number of silos	Silos built in 1913	Average Capacity, tons
Ohio.....	10,560	3,432	51
Michigan.....	10,812	1,088	93
Indiana.....	11,500	2,760	105
Illinois.....	17,340	5,202	101
Wisconsin.....	41,535	8,236	101
Minnesota.....	2,414	516	113
Iowa.....	16,236	3,267	115
Missouri.....	6,726	2,679	110
Kansas.....	6,510	1,680	123
Nebraska.....	3,240	900	132
North Dakota.....	770	250	100
South Dakota.....	1,300	455	120
Oklahoma.....	1,360	460	160
Total.....	130,303	30,925	

"It will be noted that almost one-fourth of the total number of silos

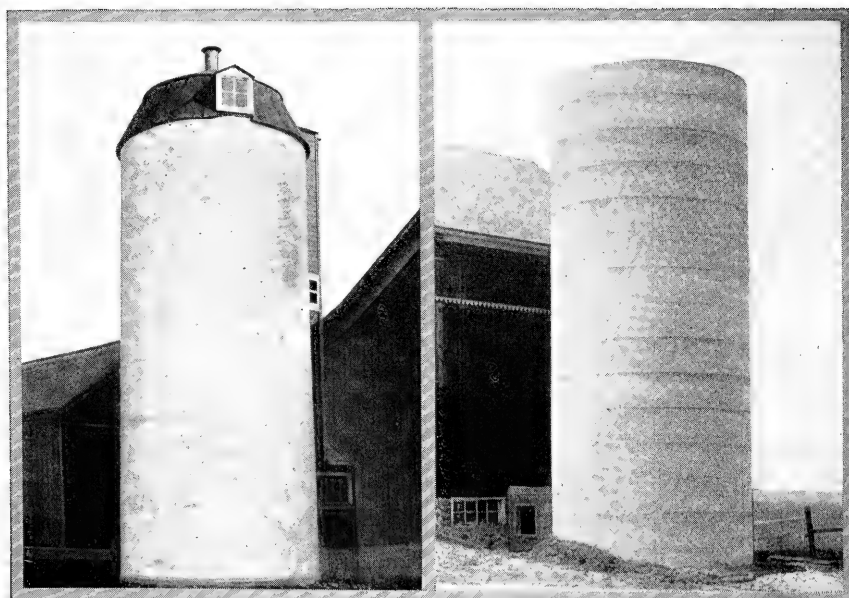

Successful Wisconsin Silo. Limberg molds used. R. Evan's Concrete Silo near Berlin, Wisconsin.

now in use were built during 1913, and in all probability at least one-half were built within the last two years. Of course, by far the greater number are as yet in the dairy regions, Wisconsin, Northern Illinois, and Iowa easily leading in numbers; but the states in which cattle feeding is most practiced are the ones that now show the largest percentage of annual increase. Central Indiana and Illinois, the north half of Missouri, eastern Kansas and Central Oklahoma are beef-producing districts that are marked by a rapid silo development during the past two years.

"The use of the silo in feeding beef cattle is responsible for an increase in the average size of the silo. The size of the silo depends upon several factors, the principal being the daily consumption of silage, as the top must be removed promptly and uniformly over the whole surface, and as the amount required daily for the average dairy herd is less than the amount required for a feed lot of steers, it follows that the use of silage in meat production has resulted in the erection in the last two years of silos of larger capacity.

"The economic importance of the present development of silage feeding would be hard to overestimate. About 70%, or roughly, 75,000,000 acres of our corn area is used to produce corn to be fed upon the farm. Husking and gathering this corn not only constitutes one of the hardest manual tasks performed upon the farm, but is one of the largest items of cost in growing corn. An average acre of corn land produces perhaps one ton of corn on the cob and 11 tons of stalks, blades and husks when cured to a reasonable degree of dryness.

*Large  
Economic  
Importance*

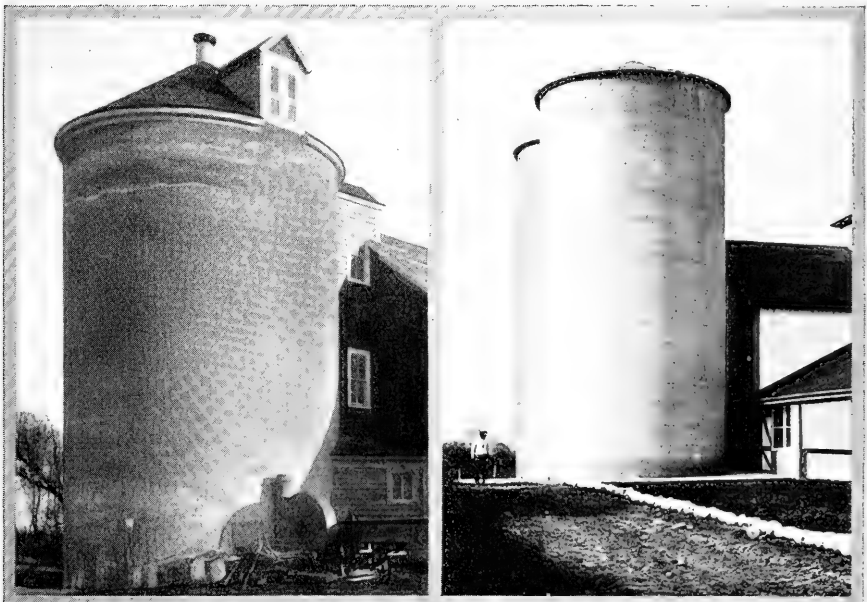

Minnesota Concrete Silo, erected on F. W. Murphy's farm, Wheaton, Minnesota, by Martin Peterson, Contractor.

Concrete Silos (dimensions 18 feet by 44 feet) on Wakefield farm, Barrington, Illinois, built by Reichert Manufacturing Co., in 1912.

"In the great corn belt of the West the ears are husked and then the kernels are shelled off, such separation involving great labor and expense.

*Eleven Tons  
of Corn  
Wasted*

Then the 11 tons of feeding material is allowed to go to waste, an incumbrance in the field, except as a small part is utilized by the pasturing of cattle for a few weeks at the close of the year.

It follows that on 75,000,000 acres devoted to the growth of feed for farm animals by far the greater part of the annual growth of feeding material is absolutely thrown away. The use of the silo will prevent this waste and make it possible to utilize in meat production 12 tons of feeding material per acre instead of the one ton now so utilized.

"The silo furnishes a means of bridging the widening disparity between meat production and population, through a complete utilization of the feeding stuffs produced and the consequent ability to grow and fatten more cattle per acre of farm land than is possible under any other form of cattle feeding."—*Orange Judd Farmer, Chicago.*

"During the last year we have heard a great deal about the virtues of 'alfalfa on every farm.' Big alfalfa stories have been going the rounds like wildfire. Fortunately they are mostly true. Alfalfa growers have no excuse for lying about the value of their crop. They find the plain truth sounds big enough—oftentimes too big. This alfalfa phrase is worthy and the idea it conveys merits universal support and encouragement. More alfalfa leads to better farms and more prosperous farmers. There is no question about it. We would propose

*"A Silo on  
Every Farm"*

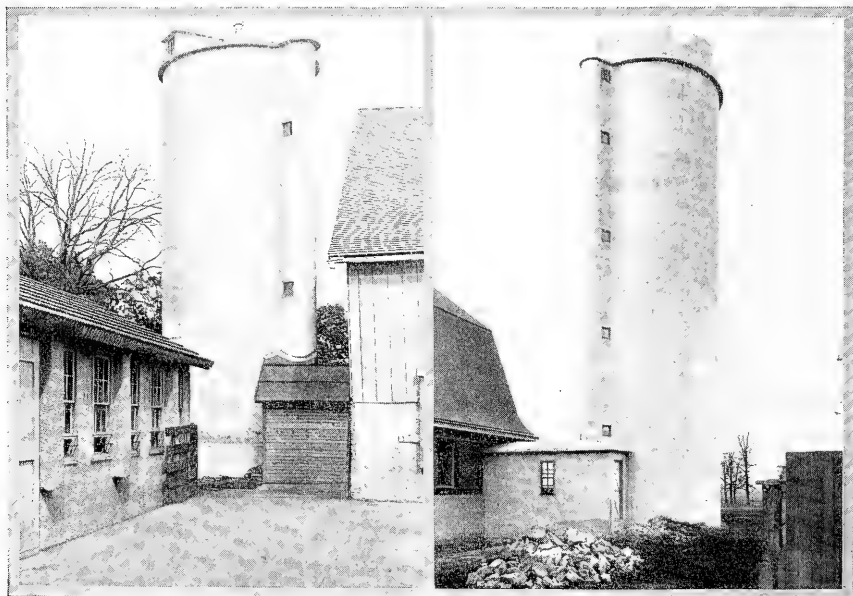

Concrete Silo on farm of H. Stillson Hart, Earrington, Illinois, visited by delegates to Conference on Permanent and Sanitary Farm Improvements, August, 1913.

Concrete Silo with Concrete Roof, Chute and Feed House built on the Kane County Farm near Geneva, Illinois. Also visited by delegates to Conference.



a companion phrase—‘*A silo on every farm.*’ We wish these two might be displayed on the same banner, extolled from the same platform and preached everywhere, publicly and privately. Where one is the other ought to be. They are profit makers for every farm. Alfalfa and silage come nearer solving the live stock problem satisfactorily, than any other combination on the farm. While we are talking and advertising alfalfa, let us not forget to put in a good word for the silo. They should go together. Every farm and farmer needs them.”—*The Farmer’s Review, Chicago.*

“Silage forms the bulk of the ration of the cows during the winter and is used to supplement the pasture in summer. Cotton seed meal is used to balance the corn silage. At no time is corn, outside of silage, fed heavily. Mr. Tasker has been feeding silage for seven years and finds it to be a great help in producing baby beef cheaply.”—*Prairie Farmer, Chicago.*

**Silage Makes Baby Beef Raising Profitable.**

“Silos are more numerous this year than ever before. The farmers are beginning to realize that the silos are really necessary in a dry season and every dry season teaches them to look for another. That is the reason so many are insuring their future feed supply by building this year.”—*Kimball’s Dairy Farmer, Waterloo.*

**Silos More Numerous in 1914**

“Fairview Farm is a leader in every way. Mr. Hall’s cement silo was the first to be erected in his community. It was built eight years

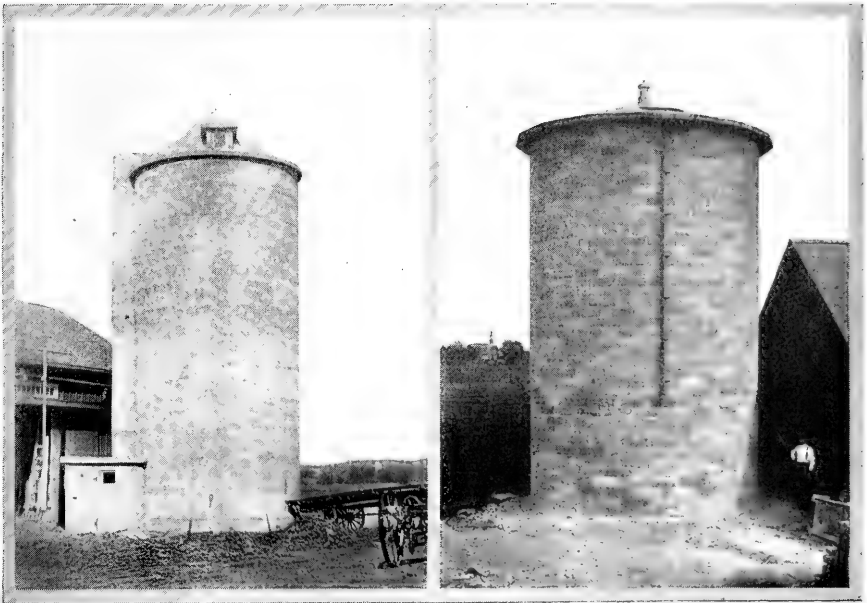

Monolithic Concrete Silo built in 1910; inside dimensions 14 feet by 45 feet. Built by Ed. Kuharske, Rockford, Illinois, for Hugh Ferguson.

Concrete Block Silo with reinforced concrete roof built by the Renwick Cement and Tile Co. of Renwick, Iowa.

**Concrete Silo  
Cyclone-  
Proof**

ago. Many inspected it and predicted that it would be useless in a few years. Not only has it stood the test of time, but it has weathered a cyclone which two years ago ruined many buildings in that locality. An idea of its stability may be gained from Mr. Hall's assertion that an iron flagstaff which was imbedded in the cement was broken completely off by the storm, but the silo was uninjured."—*The Farmer's Review, Chicago.*

"Silage is of prime importance as a feed, because it enables the cows to produce milk and butter more economically than on dry feed alone.

**Silage of  
Prime  
Importance**

Compare this with a juicy, ripe apple and the green, dry fruit. If you have a silo full of good, well matured corn, you can look the cow square in the face and be glad."—*The Farmer, Saint Paul.*

"Investigations conducted by the Dairy Division of the U. S. Dept. of Agriculture during the past few years with 87 silos in various parts of the United States, indicate the cost of filling to be an average of 87 cents per ton. The cost of growing the silage crop was \$1.58 per ton on the average, which added to the filling cost makes the average total cost of silage \$2.45 per ton. However, no definite statement can be made as to the exact cost of silage as so much depends upon the yield per acre, cost of production, and other conditions that vary so greatly in different sections of the country. For the individual

**Cost of  
Silage**

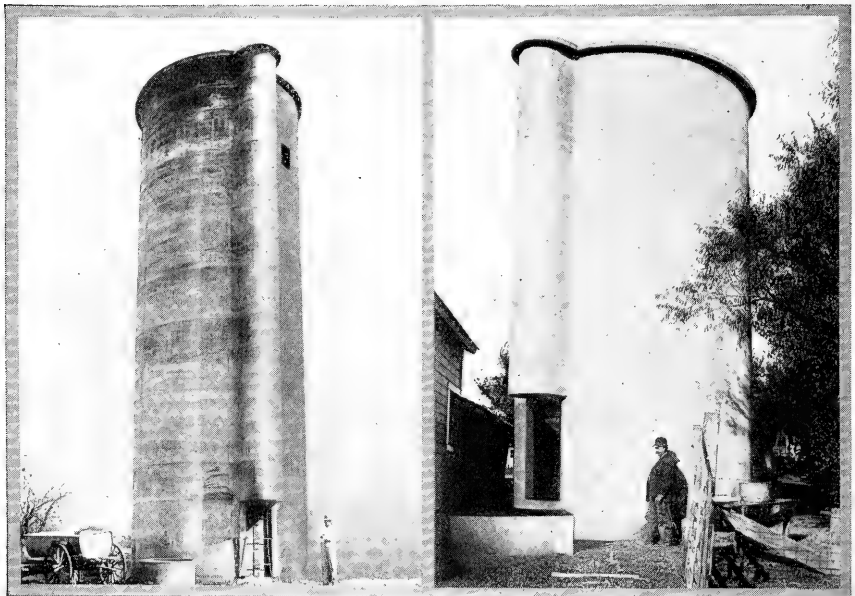

Reinforced concrete silos are popular in Kansas. This one is 12 feet by 32 feet; capacity 75 tons, on the Newtown Farm, Winfield, Kansas. Concrete chute and roof. Monsco forms used.

Concrete Silo with Tank on Top. Size of silo, 14 feet by 48 feet; capacity 148 tons; water tank capacity, 10,000 gallons; erected with Monsco forms on the farm of E. D. Elliott, Floral, Kansas.

farms under consideration the cost of silage varied from \$1.10 to \$5.42 per ton. The investigators state that \$1.50 to \$3.50 per ton represents the limits between which most of the silage is produced."

—*Hoard's Dairyman, Ft. Atkinson.*

An Iowa correspondent writes to Wallace's Farmer asking:

*Value of  
Silage*

"What in your estimation is the value per ton of corn silage made from corn averaging fifty-five bushels per acre, and stored in a silo eighteen feet wide by thirty-four feet high? This silage is of very good quality. In case I should buy it, I would have to commence taking it from the top."

"Under present conditions, it costs from 50 cents to \$1 to put a ton of silage into a silo. Probably the average would not be far from 65 cents. This includes cost of cutter, engine, coal, man and horse labor, etc. Seventy-five cents per ton should cover the interest on the investment in the silo, depreciation, insurance, etc. The other item to be considered is the value of the corn fodder per ton if it were not put in the silo. We will assume that our correspondent's fifty-five bushel corn would make twelve tons of silage, and that the stalks are worth \$1 an acre. To the ear corn we will assign a value of 65 cents per bushel. This is assuming a market value of 70 cents, and deducting 6 cents for husking. On the basis of these figures, a ton of silage should be worth about \$4.45. If the market value of corn were 45 cents per bushel, the value of a ton of silage would be \$3.16.

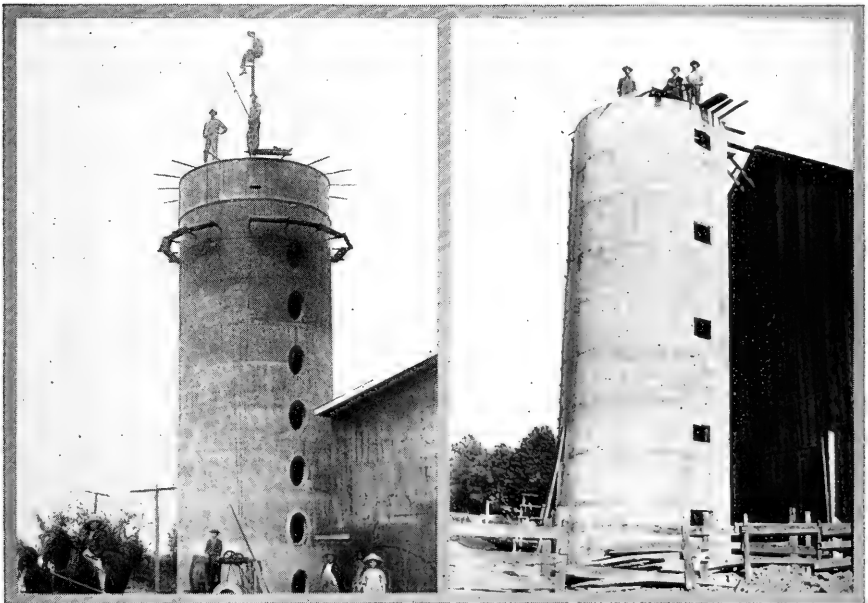

Frank Leach's Monolithic Silo (dimensions 14 feet by 48 feet) near Chesterfield, Illinois, built by Perry Duckles, Carlinville, Illinois. Polk forms used.

Fire proved this concrete silo, another picture of which is shown on page 47; the second monolithic concrete silo built in either the United States or Canada. McCoy forms used.

“These figures are merely suggestive. In any particular case they must be applied with judgment, and other things must be taken into consideration. It would seem fair, however, to make the market value of corn less the cost of husking per bushel, the yield per acre in tons of silage, cost of siloing, and the quality of the silage, the determining factors in securing the valuation of silage.”—*From Wallace's Farmer, Des Moines, Iowa.*

*The Silo in Summer* “Dairymen who have a supply of silage which will be available are most fortunate and have simplified the matter of feeding their cows successfully through the summer. Sunburned pastures present no terrors for them. Experiments have proved that good corn silage is equal to green soiling crops for summer milk production and is much more conveniently fed to cows than are green soiling crops which have to be hauled from the fields.”—*The Farmer, Saint Paul.*

*It Pays for Itself* “Feed bills which have been saved this winter through the use of the silo cannot be estimated. One correspondent declares that his new silo ‘has practically paid for itself’ this first year. Another says ‘the silo is the greatest money saving investment I ever made. I am going to build another this summer.’ It is the same story all along the line—what they all say after a fair trial of the silo. There is no investment which pays better interest and dividends from the very start. A live stock farmer without a silo in these days is working under a serious handicap so far as economical profits are concerned.”—*The Farmer's Review, Chicago.*



Two Concrete Silos with Concrete Chutes built in Wisconsin with W. A. Limberg's patented molds.

Polk Silo in Process of Construction in Missouri, showing method of operating forms.

The supposed effect of silage acid on concrete has been one of the most widely discussed and at the same time the most absurd of the many common silo fallacies. Silage acid is one of the weakest acids known to science. It does not miraculously preserve wood nor destroy concrete, neither does it affect cows' teeth nor their hoofs or horns. It does not eat out their stomachs and has no bad effect upon them whatsoever. Silage juices will not eat away concrete nor injure it in the slightest degree, which is proven by the fact that after years of service the concrete foundations of hundreds of silos built of other material still show, to-day, the trowel marks which were made at the time constructed. If the silage acid had any effect whatsoever, it would only be a few months when the floor (of all places) would show the effects.

Many a dairyman, who has successfully fed silage to his cows for years, is told by his neighbor who raises sheep or hogs that silage is all right for dairy cows but it is not good for his animals. This, of course, is absurd, but it should be remembered that the stomachs of animals like cows (which have four stomachs holding 40 or 50 pounds of silage in 24 hours) are different from the smaller and more delicate stomachs of horses or sheep. Hogs relish silage but they, again, have different kinds and sizes of stomachs than the other animals mentioned. Silage is also fed to chickens and other poultry with great success. It might be mentioned, at this time, that the average silage ration for cattle runs from 30 to 50 pounds daily; for horses, not as a rule, over 15 pounds and the silage must be of excellent quality, as the horse is a dainty feeder; for sheep, not over 3 pounds daily; for hogs, from 3 to 5

*Concrete  
Unaffected  
by Silage*

*Care  
Required  
in Feeding*

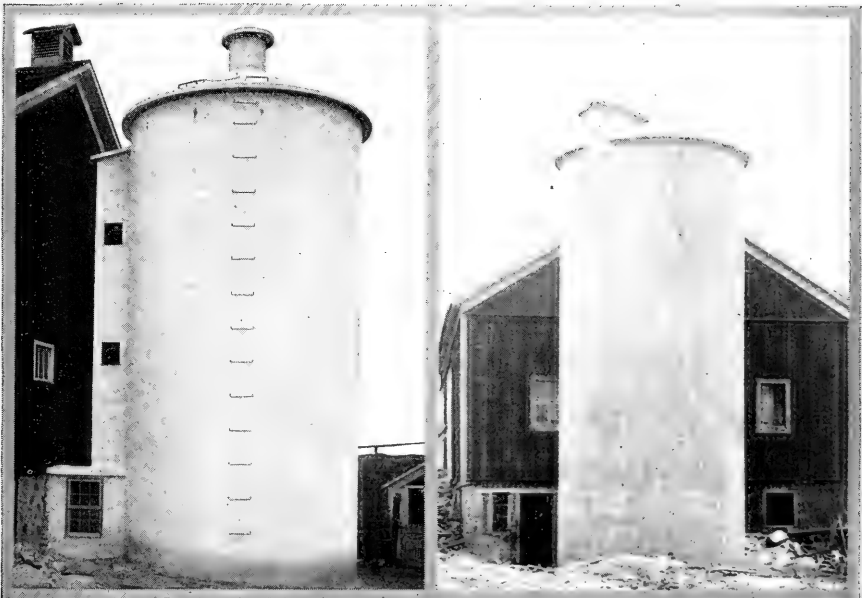

Sixteen Concrete Silos similar to illustration have been built by John Stahl of Hayton, Wisconsin.

Concrete Silo. Built by R. C. Angevine for S. S. Lee of Lowell, Michigan.

pounds, and for chickens it should be placed in clean receptacles and fed to them like any other green stuff. Animals which have never been fed silage should be started on a very small quantity for a few days, just as other new foods are given only in small quantities at first, by the careful feeder.

“In a recent issue of ‘The Farmer’ an exchange article was run which would give the impression that concrete is injuriously affected by the acid in silage juice. This certainly would be a mistaken idea, as there is absolutely no evidence we can find to show but what concrete is just as enduring in a silo wall as anywhere else. \* \* \* \* \* Our observations are that silage juice has absolutely no perceptible effect upon concrete.”—*The Farmer, Saint Paul.*

“There is nothing about concrete that produces mold in silage. If a concrete silo is properly made it will preserve silage well, whether it be built above or below the ground.”—*Hoard's Dairyman, Ft. Atkinson.*

“It will not injure dairy cows to feed them all the silage they will eat providing it has been properly made and is not moldy.”—*Kimball's Dairy Farmer, Waterloo.*

A subscriber to “Hoard's Dairyman” asks, “Which kind of silo keeps ensilage the best, wood or cement?” This is answered in the March 27, 1914, issue.

“A cement or concrete silo, if properly built, will keep ensilage as well as any other type of silo. The secret of success

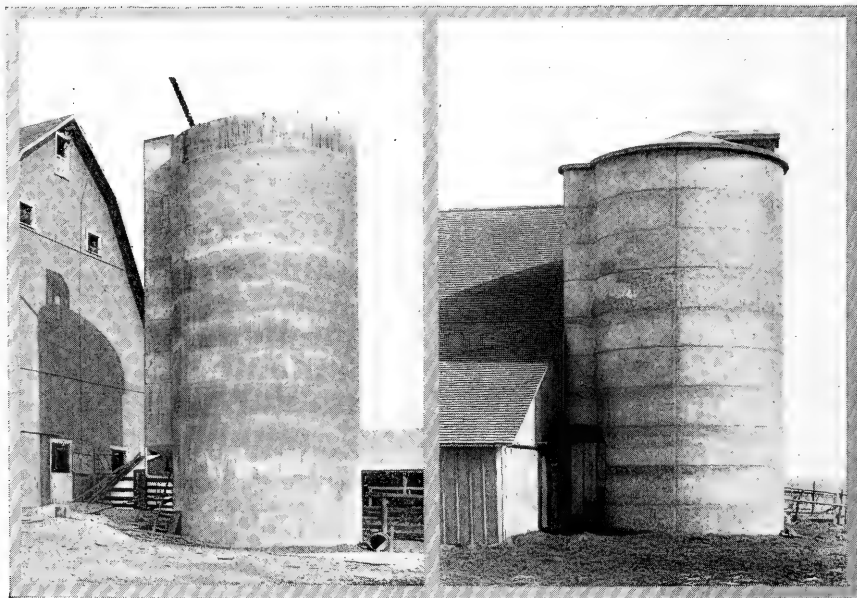

Monolithic Silo (McCoy forms used) of Roy Hagler of Washington Court House, Ohio, built by James Wilt.

Ward Swift's silo near Streator, Illinois, built by Armstrong and Co. of Streator. Note concrete roof and concrete chute.

in building a concrete silo is largely in the mixture used; 1 part cement, 2 parts clean, sharp sand, and 4 parts clean gravel or crushed rock are recommended."

"Silage has very much the same effect upon the cow's digestive apparatus as pasture grass."—*Kimball's Dairy Farmer, Waterloo.*

*Cock and Bull Stories*

"Every now and then some cock and bull yarn is started by ignorant men as to evil effects of ensilage. No one can stop them. They are a natural product of ignorance. Disraeli once said that 'even Providence could not provide for the unforeseen machinations of stupidity.' About once in so often we are called upon to dispute the statement that ensilage injures the teeth of cows. The latest tomfoolery of that kind is that ensilage causes acidity in the soil, and we notice Dr. Hart of the Wisconsin College of Agriculture feels called upon to dispute it. But the worthy doctor has an interminable task ahead of him if he puts down every ignorant tale that is told about the silo and about ensilage."—*Editorial, Hoard's Dairyman, Ft. Atkinson.*

*Deep Silos*

"It is more difficult to keep silage in a silo 24 feet deep than in one 30 or 40 feet deep. The deeper the silo, the more likely the silage is to pack tightly together and keep out air. In early days, when silos were made only 15 or 20 feet deep, they found it necessary to put weights on top of the mass in order to prevent spoiling."—*From Wallace's Farmer, Des Moines, Iowa.*

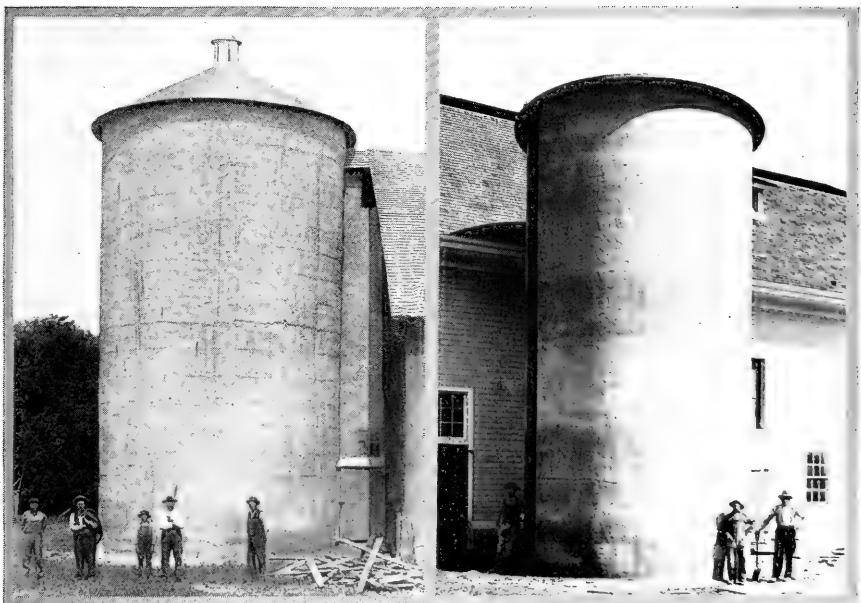

A Minnesota Concrete Silo built by farmer A. L. Liske of Henderson, Minnesota, who used home-made forms.

A Fine Example of Permanent Construction. A reinforced concrete silo and concrete roof which will probably stand for centuries.

“Silage will keep, if properly put up in a good silo, from 3 to 4 years. Silage does not ‘cook.’ It ferments and it does not matter whether there is 6 inches of concrete, 2 inches of wood,  $\frac{1}{4}$  inch of iron, or what kind of construction is used in the walls. The heat is caused by the fermentation and the loss through the walls is so small that it is entirely negligible. The temperature due to fermenting may rise to 130 to 140 degrees Fahrenheit.

*Temperature  
and Qualities  
of Silage*

“A silo that is air tight will hold the moisture. There is nothing more mysterious in putting up silage than there is in putting up sauer-kraut. The confusion arises usually because agents of different kinds of silos try to make differences where none exist.”—*Hoard's Dairyman, Ft. Atkinson.*

A Wisconsin dairyman writes to “The Farmer” of St. Paul, asking if it is true that dairy cows fed on silage live only about five years. The answer is:

*Silage  
Prolongs  
Cows' Lives*

“There is positively nothing in such a report; as a matter of fact, cows fed silage will generally outlive cows that are not fed silage or some other such succulent feed.

“The Minnesota Experiment Station of St. Paul has a greater number of records of old cows than perhaps can be found anywhere else in the United States; that is, cows that were raised from calves and continued in the herd until they died of old age, most of them over fifteen years and profitable to the last year. These cows are fed silage the year around, from twenty to forty pounds a day. This is surely evidence that cows will live their natural life when fed on silage.”

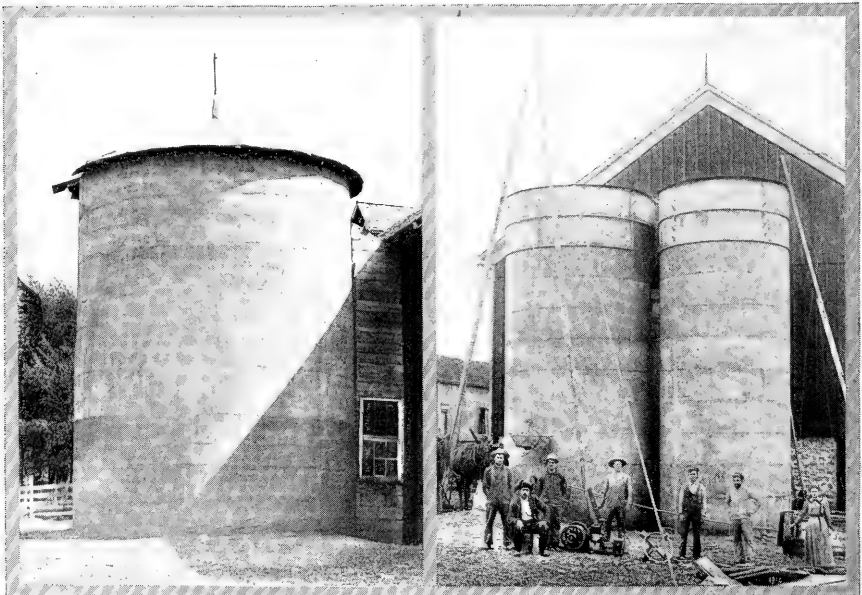

Northern Wisconsin's First Monolithic Silo—built by G. W. Graham of Roberts, with Wisconsin Farmers' Institute silo forms. (See illustration on page 56.)

Successful Reinforced Concrete Twin Silos built with molds patented by W. H. Limberg of Plymouth, Wisconsin, who is an inventor and a silo contractor.



## Silage for Beef Cattle

Time was when one could usually find a dairy farm, by locating a silo, but that time has passed. Silage is acknowledged to be the best feed for dairy cows. The high cost of feed has necessitated the use of some cheaper feed than grain, some better method than pasture on the beef feeder's or stock raiser's farm. There is no cheaper feed than silage and it can be fed to excellent advantage to beef cattle, as repeated tests at the University of Illinois and at Purdue University have shown. The day for fat cattle has also passed, if one is to judge from the last International Live Stock Show, and from the recent trend of the market. Baby beef seems not only to be most popular but most profitable. It has been shown conclusively that baby beef can be brought forward more rapidly and cheaply, on silage as a maximum ration, than on any other feed. The successful beef feeder to-day, to make the largest profits, must of necessity have a silo and feed silage. This is as true of Indiana as Kansas. It is as true of Oklahoma as Minnesota. The beef feeder will do well to look into this question and get reports from his State Experiment Station, and if these do not give fully the information desired, it is suggested that he write for further information to the State Experiment Stations at the University of Illinois, Urbana, Illinois; Purdue University at LaFayette, Indiana, and to the Ohio State University, at Columbus.

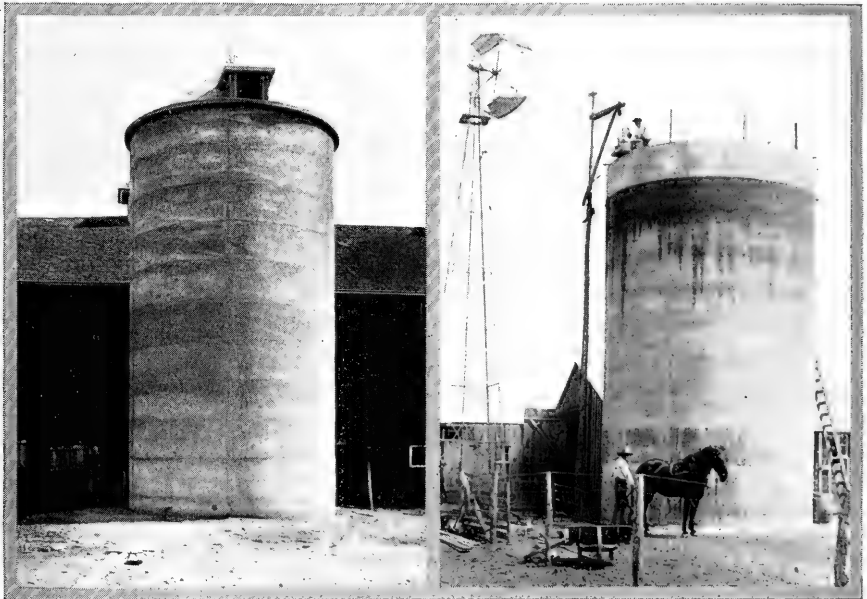

Monolithic Concrete Silo built by S. E. Griffith for S. L. Covey, Belvidere, Illinois; looks and is substantial

Concrete Silo in process of construction on Green Brothers' Farm, Morgan, Minnesota. Built with farm labor.

“That was one of the sights of the International—Brother Leo and his fat bullocks. Last year, at the same show, he secured them when they were the prize yearlings in the feeder class. He took them to the great farm at Notre Dame University and fed them. *They had silage all summer long and never a bite of grass*, for Brother Leo is seeking production of prime beeves. With the silage they had grains, of course. The result is astonishing. The cattle have taken on flesh, width, rotundity; they are splendid bullocks, provoking wonder and smiles.”—*Editorial from Breeder's Gazette, Chicago.*

“One week last spring I visited the Old Cattleman to look at the new crop of calves.

\* \* \* \* \*

*Baby Beef Making Safest System for Corn Belt* “I do not shut off the silage altogether until the grass is a little solider and not so washy,” explained the Old Cattleman. ‘It makes a little bulk with which to feed the cottonseed meal to the cows. They and the yearlings get just enough of it each day so that none of it spoils. *They eat it even on the best of June grass*, at least they did last year! It is cheaper than the grass, so why not feed it?

\* \* \* \* \*

“I wean the calves in the fall. Sometimes they are only a bit over five months old. Sometimes they're as much as eight months or better. They're eating grain when they're weaned and I get 'em on full feed as soon as I safely can. They get shelled corn, oats, oilmeal, clover hay, alfalfa, *silage*, a little bran and sometimes a bit of molasses. I'd rather



Arcady Certified Milk Barn, Lake Forest, Illinois, showing litter carriers and two of six concrete silos.

buy the molasses myself and mix my feeds than buy the prepared feeds, though I have fed a little of some of them. I like oilmeal better than the cottonseed meal, for the calves, though I have fed a little cottonseed meal when the oilmeal was high. More than a pound a day of the cottonseed meal doesn't seem to be good for the calves, while I have fed three pounds of the oilmeal at a profit.

"I like alfalfa best of all the hays I ever tried. My own patch of it, though, has killed out and I'm just getting it started again. The last bunch, those in the yards, had only clover and oat hay. Of course they got silage. The silage is great stuff, but the cows get more of that than the calves do. I reckon I never feed more than 15 pounds of silage a day to the calves, and seldom that much. I used to feed some roots to the calves, and a lot to the cows, but not any more since I have silage. They cost too much to grow. Labor is too high and I don't like to bend my back over them myself. Silage is better anyhow.

"I've made yearlings weigh 1,200 pounds at 16 months in the way I've told you. The bunch in the yard will average a good bit better than 1,100 in June at 16 months. Sometimes I sell at 1,000 pounds or less. Sometimes I carry them to 1,250 pounds or better. Usually when they are fat and prime they are better sold even if they are a bit light in weight. There's not much money in holding after they are ready to go.

\* \* \* \* \*

"I like to feed the babies better than the older cattle. It's a surer thing and to me it's a pleasanter business, too, breeding them yourself."

—By Rex Beresford, Iowa Beef Producers' Association, in the *Prairie Farmer*, Chicago.

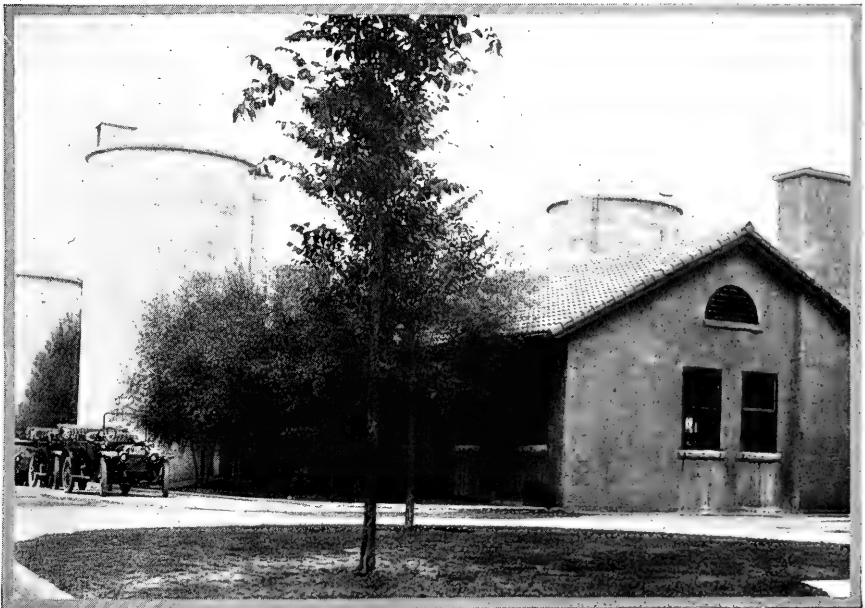

Two of the Six Reinforced Monolithic Concrete Silos at Arcady Farm, Lake Forest, Illinois, owned by Arthur Meeker.

That Indiana feeders believe in concrete silos is shown by the following letter:

*High Silos Popular with Feeders* "Editor *Prairie Farmer*: I saw an article in your March 1st issue in regard to one of the largest concrete silos in the world, 16x62 feet. We have a farmer in Knox county, Indiana, by the name of William H. Brevorte, who has built six concrete silos whose dimensions are 22 feet diameter by 60 feet high. He will build six more this year, same dimensions. He is feeding 1,000 head of cattle."—*Prairie Farmer, Chicago.*

A South Dakota correspondent writes to Wallace's *Farmer* asking:

*Value of Silage and Pasture* "Cattle can be pastured on prairie grass from May 1st to December 1st, for \$2.50. For the remaining months, corn silage can be fed. How much silage would be consumed daily by the average beef cow, by the average yearling, by the average two-year-old, and by the average three-year-old? How much gain could be expected each year from young stuff fed silage? How much gain could be expected each year from young stuff on pasture? What other feed should be fed with silage to make the most economical winter growth?"

"We do not know just how good this prairie grass pasture in South Dakota is. Good corn belt blue grass pasture will put an average daily gain on yearlings of about one and one-half pounds, and on two-year-olds of about one and two-thirds pounds. Such pasture costs \$6 or \$7 per acre for the season.

"Calves coming into the winter in fairly thin condition and fed all the



A Michigan Concrete Block silo—homemade—on farm of W. Stoll, Lansing, Michigan.

F. W. Merrill, contractor, of Kaneville, Illinois, owns the block silo illustrated above.

silage they can eat, and one pound of cottonseed meal or oil meal daily, should gain about one and one-half pounds daily. Under such conditions they should probably eat about thirty pounds of silage, a little more or a little less, depending upon the proportion of corn and water in the silage. Yearlings or two-year-old steers roughed through the winter on silage will eat thirty to forty pounds daily. Beef cows will eat forty to fifty pounds. In addition to the silage, it is wise to allow them some dry roughage, such as oat, straw, cane hay, or corn stover. It would be wise to feed them two or three pounds daily per 1,000 pounds live weight of cottonseed meal or oil meal. On a ration of corn silage, oat straw, and cottonseed meal or oil meal, yearlings, two-year-olds, or three-year-olds should make daily gains of about one and three-fourths pounds. Much depends, however, upon how thin the steers are when they are put on winter feed."

—Wallace's Farmer, Des Moines, Iowa.

In Henry County, Illinois, some of the largest feeders in the Corn Belt are also going to raise some stock, expecting to change their methods.

**Beef Feeders  
Must Build  
Silos**

Regarding this, "Orange-Judd Farmer" of Chicago says: "Clyde Ford believes they must ultimately come to use a silo, particularly if they get to handling young steers or raising their own stock." On the Hulting farm, Ed. Hulting, the manager, said:

"Under the new system of raising baby beef, I believe that silage and alfalfa will be the chief bulky part of the ration with a little grain to keep the calves always in first-class condition. They will be kept fat all the time and at the end of the year will be topped off with a short grain feed, in excellent market condition, weighing about 1,000 to 1,100 pounds."

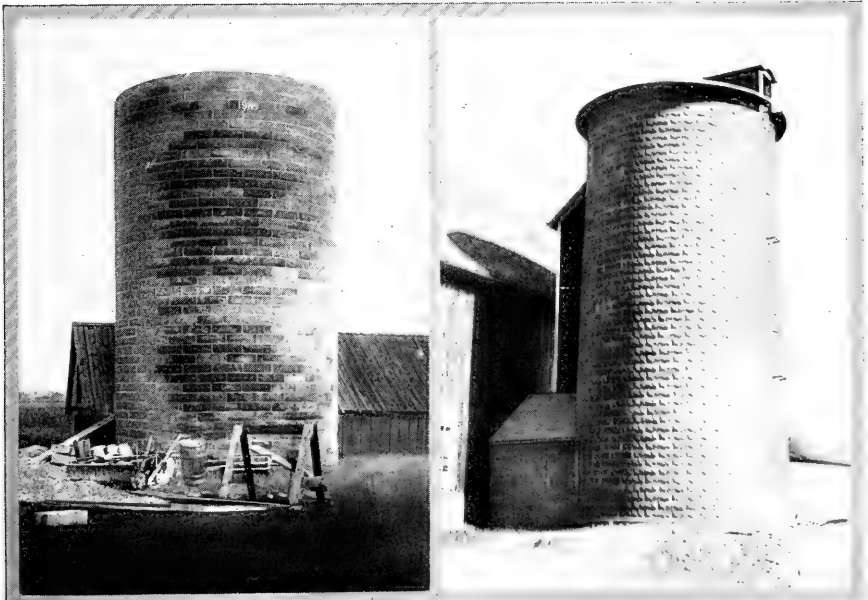

Excellent Concrete Block Silo in the heart of the butter district near Elgin, Illinois.

John Bett's Concrete Block Silo near Lake Geneva, Wisconsin. Dimensions 13x32 feet.

## Silage for Dairy Cows

Winter dairying is most profitable. This is particularly true in the northern states, as flies and other pests are eliminated by the cold weather, and it is easier to keep milk cool and clean because of the weather and the absence of flies. In many communities not only where whole milk is produced, but also where the milk is sold to creameries or cheese factories, winter dairying has been found to be most profitable if silage is fed. To get the largest milk flow and keep the dairy cow in the most healthy condition some sort of succulent food must be fed, and in some way the ingenuity of man must provide conditions similar to June pasture. Good silage practically equals this condition.

However essential silage is in winter dairying, in summer, especially in August when the pastures are sunburnt and bare, the dairyman needs to feed it. In fact, on some farms producing certified milk, silage is fed the entire year, not only because it is so easily handled in the barn in comparison with other feeds, but, also, because it is such a cheap feed. No other roughage approaches silage for low cost of storing, handling, and feeding. The silo increases the carrying capacity of the farm. Where dairy cows or other stock are fed, many more can live on the products of the same number of acres, by the use of the silo and silage.

“In practically every way the Brewster place is an ideal dairy farm.

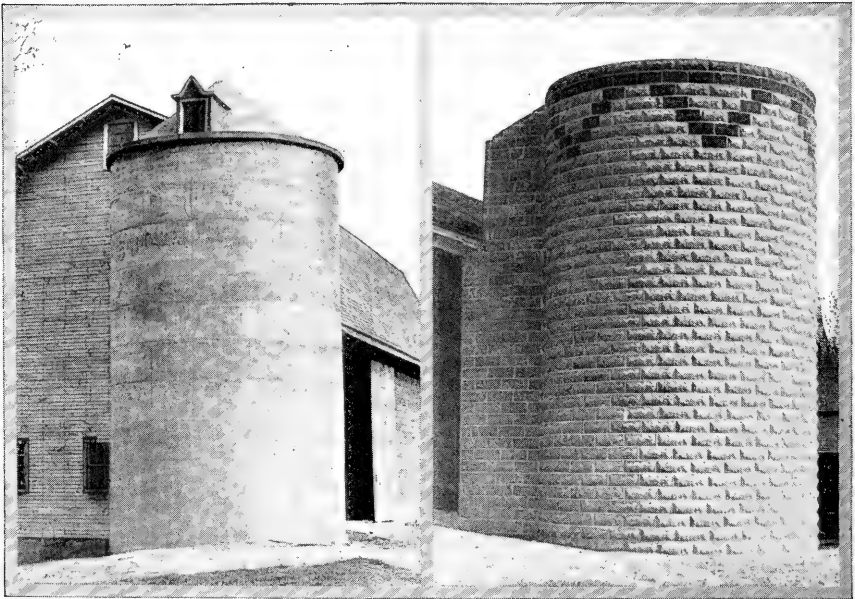

Monolithic Silo built in 1907 on farm of L. A. Crawford, near Walworth, Wisconsin.

Attractive Concrete Block Silo on Fred. Ludke's farm near East Troy, Wisconsin.

Pure bred Holstein cows, a bull valued at \$1,000, a *cement silo*, a *sanitary cow barn*, and an automobile for marketing the produce, all tend to make surroundings which may be studied with profit by any farmer.

**\$100 a  
Month from  
8 Cows**

“The sole purpose in conducting this dairy farm is to make money. In order to do this both Mr. Brewster and his wife keep careful track of their cattle and of the markets, and they spare no effort to make their investment a profitable one. From a financial standpoint it is unquestionably successful. Throughout the past summer more than a hundred dollars per month has been realized from the milk of the herd of 8 cows.

“Mr. Brewster considers the silo indispensable to the dairy farm. The one on this place is of cement construction, 30 feet high and 15 feet wide.”—*The Farmer's Review, Chicago.*

“The feeding of corn silage judiciously to a herd bull does not injure his prepotency. It is true of corn silage as of any other food, if the animal is overfed injury of one kind or another will result. Corn silage should provide only a portion of the animal's ration. All animals demand a certain amount of dry food daily, therefore hay should be fed in conjunction with silage for roughage. In addition to this, especially in breeding season, the herd bull should have a light ration of foods conducive to the upbuilding of condition and stamina. Such foods are bran, oil meal and ground oats. Where corn silage is fed as a small portion of the ration for the purpose of supplying succulence rather than food nutrients, it is one of the most valuable feeds for all kinds of breeding animals.”—*Kimball's Dairy Farmer, Waterloo.*

**Silage for  
Breeding  
Animals**



Concrete Silo at Home for the Aged, Washington, D. C.

“I have as neighbors a father and son who have been in the dairy business for twelve years, using scrub cows and without a pure-bred sire and a silo. The father has been opposed to these new-fangled things all these years, but this year I induced the son to buy a pure-bred sire and to build a silo even though his father objected to it. When they commenced to feed the silage the father saw the milk flow increase and his creamery check grow larger. I now hear him say: ‘My boy, there is nothing like a silo for the man that milks cows. If I had pure-bred cows, too, my creamery check would be larger and the farm would be more profitable.’”—*Hoard's Dairyman, Ft. Atkinson.*

*Nothing Like  
the Silo*

## Silage for Sheep, Horses and Other Live Stock

Silage is very successfully fed to sheep. A number of large sheep feeders around Chicago have been very successful in fattening sheep for market by the use of silage. There is no doubt, especially in the Corn Belt states, that sheep have come to stay. More will be raised every year, not so much for wool as for mutton. This means different methods of feeding because it is not economical on land worth over \$100 an acre to pasture them. The use of the silo and silage reduces the cost to a tremendous extent, particularly as sheep will rarely, if ever, be fed over 3 pounds of silage per day, which is equivalent to several times its weight in hay. In feeding sheep silage they should be started with very small quantities and no spoiled silage should be fed them or, in fact, any other animals. Spoiled silage is no different from any other rotten food

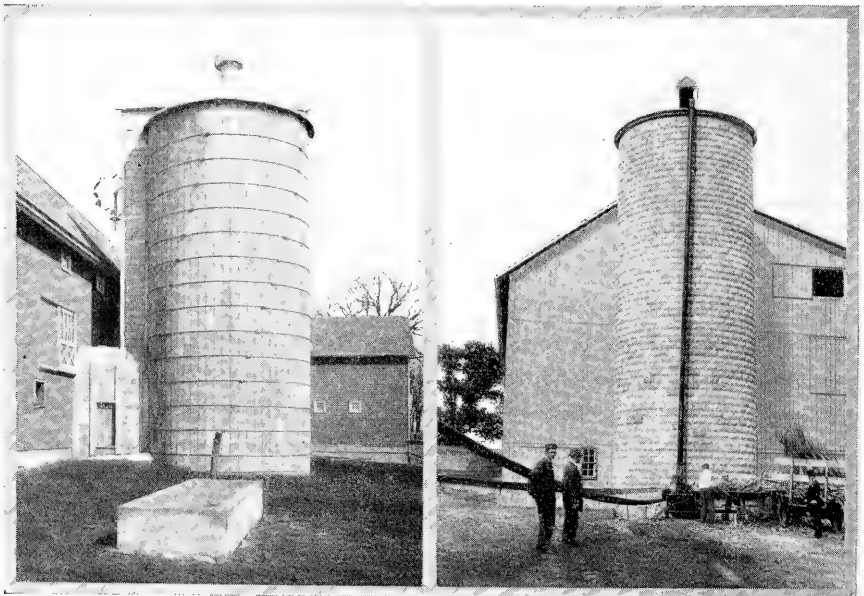

Cement Stave Silo, Bosworth Brothers' farm. Built by Cement Stave Silo Co. of Elgin, Illinois.

Concrete block silo on Courlund Marshall's farm near Rochester, Ohio. Built by V. W. Burge.



and there is no excuse for feeding it any more than the farmer would deliberately give his animals contaminated water or moldy hay. Common sense is more needed in feeding silage to sheep and horses, than other live stock, because of the small quantities of any food their stomachs will hold at one time.

Silage is good for horses. It can be fed to them in amounts varying from 7 to 15 pounds a day. Here again care should be exercised and the horse should only be fed small amounts at first until he gets used to the new ration. Where silage is used for roughage, concentrates must be fed. Alfalfa and corn silage makes an almost ideal balanced ration for horses and a very cheap one as well.

Silage has been fed successfully not only to horses, but to poultry of all kinds. Chicken silos are advertised, but as a matter of fact, a large silo, preferably a tall one, with not too great a diameter, is most economical, as from it, at all times of the year, a succulent ration is provided for beef and dairy cattle, sheep, horses, hogs and poultry of all kinds.

“For four years now, we have been in the business of feeding western lambs. For the first two years we fed without a silo and for the last two years with a silo. It is easy for me to say that we are well pleased with the results we have gained in using silage for feeding lambs.

“Our silo is a cement stave silo 12 feet in diameter and 35 feet high with a capacity of 100 tons. It cost us \$350 complete. From this silo this winter we fed 700 lambs, 1 cow, 3 horses and 500 chickens. They emptied it in one hundred and ten days.

*The Silo a  
Valuable  
Adjunct in  
Sheep  
Feeding  
Operations*

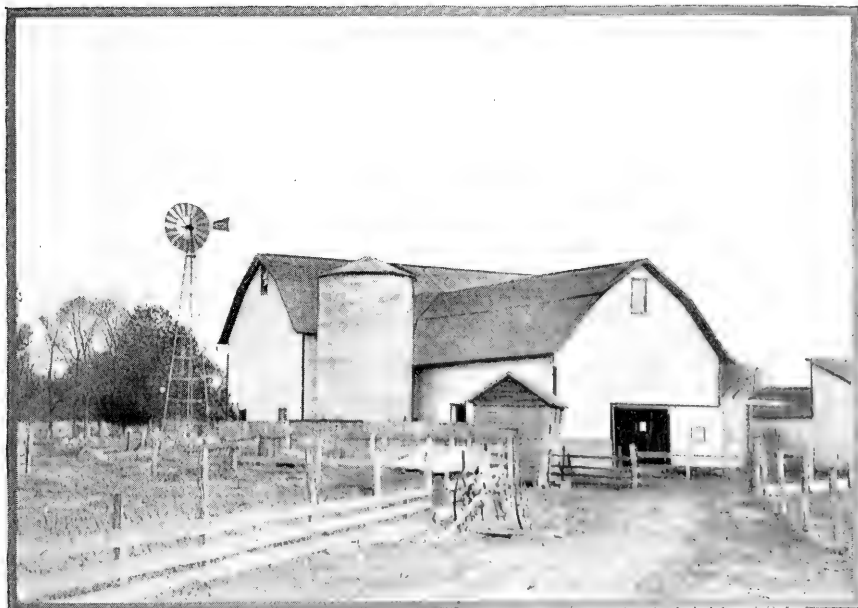

H. M. Hatch's Silo at Lake Geneva, Wisconsin. Capacity, 110 tons. This silo has paid for itself many times since it was erected.

"The lambs ate about 3 pounds per head a day to start with, but as soon as we got them onto full feed of grain they came down to about 2 pounds per head a day. It takes us about thirty days to get them on full feed.

"We fed these lambs this winter, that is when they were on full feed, for about ninety days, allowing each  $1\frac{1}{4}$  pounds of shell corn;  $\frac{1}{8}$  pound of oil meal;  $1\frac{3}{4}$  pounds of silage and  $\frac{1}{3}$  pound of clover hay a day, with all the salt and water they wanted all the time."—*The Farmer's Review, Chicago.*

According to extracts from "Farmer's Bulletin No. 556," U. S. Department of Agriculture, silage is an excellent feed for horses if used with care. It is not safe to feed horses moldy silage, frozen silage or a large quantity of silage. Carelessness in feeding horses silage, if it is moldy, or feeding moldy hay or corn will result fatally.

*Silage for Horses*

That silage for horses has a distinct and definite value for the careful and practical farmer is shown by the following quotations:

"The value of silage for horses is greatest as a means to carry them through the winter season cheaply or to supplement pasture during drought. To cheapen the ration of brood mares, in winter, no feed has more value than good corn silage. If grain goes into the silo with the stover no additional grain is needed for brood mares, hay being the only supplemental feed necessary. If there is little grain on the corn the silage

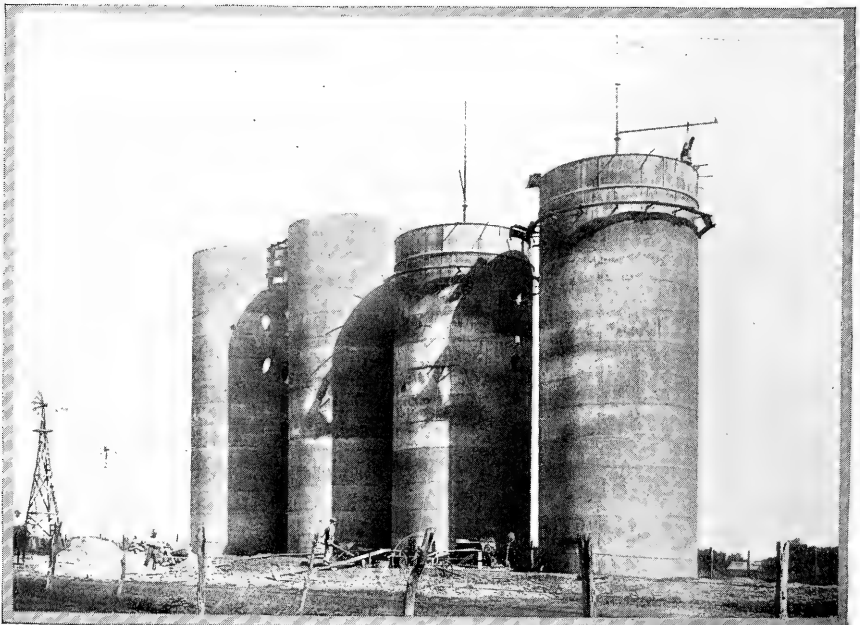

Four in a Row—all reinforced concrete silos, near Manhattan, Kansas (16 feet by 60 feet inside dimensions), built for H. G. Adams, Maple Hill. Probably the largest silos west of the Mississippi River.

should be supplemented with 1 pound of old process linseed oil meal or cottonseed meal daily per 1,000 pounds live weight, sprinkled over the silage.

"Horses to be wintered on a silage and hay ration should be started on about 5 pounds of silage daily per 1,000 pounds live weight, the grain and hay ration being gradually decreased as the silage is increased until the ration is 20 pounds silage and 10 pounds of hay daily per 1,000 pounds live weight. It will require about a month to reach the full feed of silage, but the period may be decreased somewhat, depending on the judgment and skill of the feeder.

"Mares fed in this manner will be in splendid condition for foaling, and, so far as the writer's experience goes, the foals will be fully as vigorous, with just as much size and bone, as if the mares were fed the conventional grain and hay ration."

"Corn silage is exceedingly valuable feed for dairy cows, and during the past few years especially, since it has been put in the silo in a more mature condition, it has proven to be a very economical feed for growing young cattle and for fattening them for market. If the corn is not cut until after the ears ripen with the most of the leaves still green, it produces the best quality of silage for fattening purposes. In fact, it is better to let it get a little over-ripe so that it is necessary to use water to make it pack in the silo than to cut it too green. Immature corn not only produces less feed to the acre, but silage from such corn is more apt to sour and is less valuable for feeding

*Silage for  
Dairy Cows  
and Hogs*



Excellent concrete block silo, built in Iowa by Anchor Concrete Stone Co., Rock Rapids.

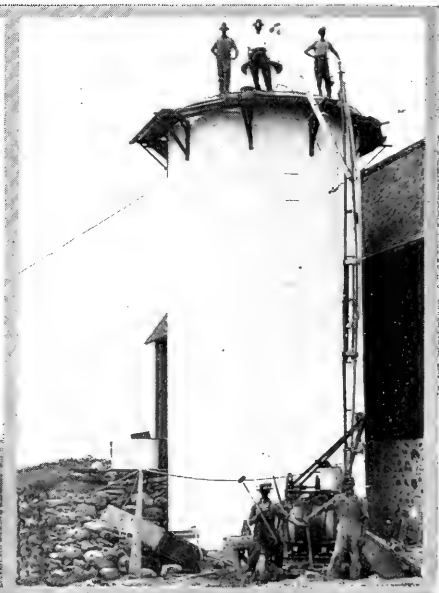

Monolithic Concrete Silo built by Peter Oskoe, Neenah, Wisconsin, for Emil Black.

purposes. Good silage fed in moderate quantity in connection with grain and some dry roughage makes a very satisfactory ration for any class of cattle.

"It would not pay to build a silo for hog feeding only, because the hog is not able to handle a large quantity of bulky feed. The stomach of the hog is small and they must be supplied with a large proportion of concentrated material like corn, wheat, shorts, etc. For best results in fattening hogs, it would be impractical to have the ration more than one-fifth bulky feed. Brood sows which have their growth can, of course, take a much larger quantity of such feed. For this reason it would not be profitable to give fattening hogs more than a small quantity of silage, not to exceed one pound per day to a 200-pound fattening hog. A brood sow weighing 300 pounds could use to advantage double that quantity. If you have enough cattle on the farm to make a silo worth while, it will no doubt pay to feed a small quantity each day to the hogs, otherwise not."—*The Farmer, Saint Paul.*

Pea vines, once considered waste products, have been used very successfully in making silage and in fact this method is of benefit, as proved by the following extract from Hoard's Dairyman:

"Pea blight is said to be due to a parasite fungus that winters on the vines and that it can be prevented by the simple expedient of  
*Pea Blight* ensiling the vines and feeding them to the cattle."—*Hoard's Dairyman, Ft. Atkinson.*

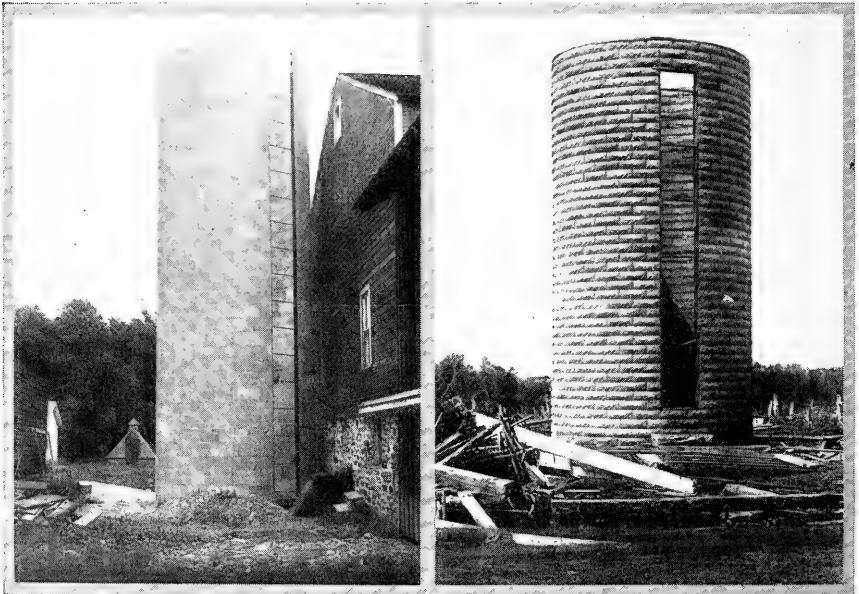

No trouble about concrete block silos standing when empty. H. M. Ashfy of Geneva, Iowa, owns the silo illustrated above; built by G. C. Harvey of Geneva.

Although empty, the concrete block silo of Dr. H. W. Tuttle of Adrian, Missouri, successfully resisted a cyclone which destroyed all surrounding buildings.

## Silage Crops

*Corn,  
Principal  
Crop*

As alfalfa is king of forage crops, so is corn the best of the silage crops. If some one would come from a strange, far off country and tell the farmer of a new sort of a building which would house 300 to 500 tons of fodder and keep it all the year around and he had a wonderful seed from some foreign country which would produce from 4 to 10 tons of provender per acre, how quickly all the farmers would be greedy and willing to purchase his entire supply. Corn is the crop and the silo is the building by which both these seeming miracles can be accomplished.

*Numberless  
Silage Crops*

In addition to corn; alfalfa, clover hay, Kaffir corn, sugar beet tops, pea vines and dozens of other crops have been successfully siloed. In Kansas, particularly, alfalfa, otherwise ruined by rain, has been taken dripping with moisture, dumped into concrete silos and saved. It has been thought best, however, by eminent authorities, to use corn as the greater part of the silage. If other fodder, particularly nitrogenous crops like alfalfa or clover, are siloed, they should be in the proportion of about 1 to 2—that is, 2 parts corn to one of the other. The fermentation of the corn seems to have a beneficial effect upon the other crop, so that in the process of fermentation it does not sour or turn black as sometimes when handled alone. Every day new

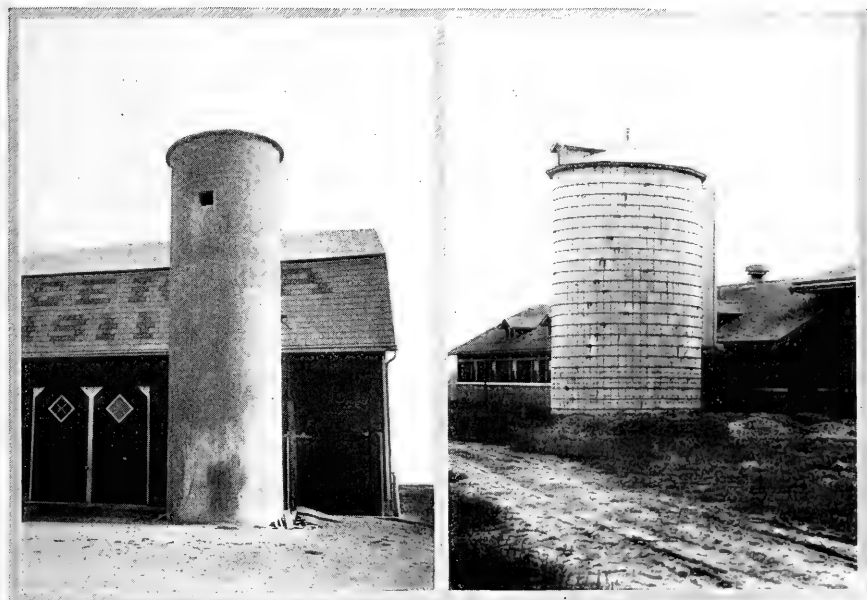

Excellent example of high concrete silo of comparatively small diameter.

Cement stave silo 18 by 30 feet, on State of Minnesota Farm, St. Paul.

uses are being found for the silo and new crops successfully put up. Where a crop is in good condition there is no reason why it will not keep in a silo better than anywhere else, provided, of course, that the silo is air tight, and stays air tight.

“Corn is universally recognized as the greatest of the silage crops. Its large yield of grain and fodder under fair conditions is remarkable.

*Corn as Silage* Corn, on bottom land farms, will produce from 6 to 20 tons of silage per acre (in Oklahoma). The general average for Oklahoma is, however, much lower, ranging from 9 to 12 tons per acre. This wide difference indicates that for maximum yields corn should be grown on bottom land as far as possible, and kaffir and milo may be reserved for the upland.”—*Kimball's Dairy Farmer, Waterloo.*

### Capacity of Round Silos in Tons

Inside Height of Silo in Feet	INSIDE DIAMETER OF SILO											
	10 ft.	11 ft.	12 ft.	13 ft.	14 ft.	15 ft.	16 ft.	17 ft.	18 ft.	19 ft.	20 ft.	22 ft.
24	34	41	49	57	67	76	86	98	110	122	.....	.....
25	36	43	52	60	71	80	91	104	116	129	143	...
26	38	46	55	64	75	85	97	110	123	137	152	...
27	40	49	58	68	79	90	102	116	130	145	160	...
28	42	51	61	71	83	95	109	122	137	152	169	205
29	44	54	64	75	87	100	114	128	144	160	178	216
30	47	56	67	79	91	105	119	135	151	168	187	226
31	49	59	70	83	96	110	125	141	158	176	196	237
32	51	62	74	86	100	115	131	148	166	184	205	248
33	53	65	77	90	105	121	137	155	174	192	215	260
34	56	68	80	94	109	126	143	162	181	200	224	271
35	58	70	84	98	114	132	149	169	189	209	234	282
36	61	73	87	102	118	136	155	176	196	218	243	293
37	63	76	90	106	123	142	161	183	204	227	252	305
38	66	79	94	110	128	148	167	190	212	236	262	316
39	68	82	97	115	133	154	173	197	220	245	272	328
40	70	85	101	119	138	160	180	204	228	255	282	340
41	72	88	105	124	143	166	187	211	236	262	291	352
42	74	91	109	128	148	172	193	218	244	270	300	363
43	.....	.....	113	133	154	179	201	225	252	280	310	375
44	.....	.....	117	137	159	184	207	233	261	289	320	387
45	.....	.....	.....	.....	165	191	215	240	269	298	330	399
46	.....	.....	.....	.....	170	197	222	247	277	307	340	412
47	.....	.....	.....	.....	.....	.....	229	254	285	316	350	424
48	.....	.....	.....	.....	.....	.....	236	261	293	325	361	436
49	.....	.....	.....	.....	.....	.....	.....	.....	301	334	371	449
50	.....	.....	.....	.....	.....	.....	.....	.....	310	344	382	462

## General Information on Silos and Silage

The capacity of the silo should depend upon the number of cattle to be fed, and the length of time that silage is required. This period usually lasts from 180 to 240 days, although very frequently silage is fed almost the entire year. The following table shows the approximate amount of silage required to feed 8 to 100 dairy cows 180 and 240 days, based on a daily consumption of 40 pounds of silage per head.

### *Quantity of Silage Required, and Economical Diameter of Silo for the Dairy Herd*

Number of Dairy Cows	Feed for 180 Days tons	Feed for 240 Days tons	Diameter of Silo feet
8	29	40	10
10	36	48	10
15	54	72	12
20	72	96	12
25	90	120	14
30	108	144	16
35	126	168	16
40	144	192	18
45	162	216	18
50	180	240	20
60	216	288	22
70	252	336	22
80	288	384	22
90	324	432	22
100	360	480	22

After determining the approximate amount of silage required, the most economical diameter for the silo must be decided on. The diameter should depend upon the number of cattle to be fed, and at least 2 inches of silage must be removed each day to prevent spoiling. The diameter required for various numbers of cows is about as given in the two right columns of the table on this page. Dairy cows eat from 30 to 40 pounds of silage per day, which amount equals about one cubic foot. Horses and mules eat about one-half and sheep about one-tenth as much as cows.

The height of the silo must be such that the required capacity may be obtained with the most economical diameter, and in many cases silos have been built with a height exceeding 60 feet. The high silo of small diameter has less waste than the silo of larger diameter, and the greater weight of silage in high silos reduces the amount of tramping necessary, while silos of smaller diameter allow greater variation in the size of

the herd without loss from spoiling of silage. The only objections offered to high silos are that they necessitate more climbing, and are more difficult to fill. There are silage blowers upon the market, however, which are guaranteed to elevate silage to a height of 75 feet.

Required, a silo of sufficient capacity to feed 30 cows for a period of 240 days. Referring to table on page 37, run down the vertical column headed, "Number of Dairy Cows" to 30. Running across horizontally, it will be seen that for 240 days' feed, 144 tons of silage will be needed, and that for a silo of this capacity, the diameter should be 16 feet. Referring to table on page 36, run down the column headed "16 feet" to the numbers nearest the estimated capacity (144 tons). For a 16-foot silo of 143 tons capacity the height will be 34 feet.

The silo should be placed where it will be convenient for filling, and if possible, where the ground is firm, so there will be no danger of settlement.

*Location* Silage is heavy feed, and therefore an unhandy arrangement with respect to the feeding alley always greatly increases the work connected with feeding. One of the best arrangements for convenient feeding is to place the silo or silos at the end of the alley. If this be done, a silage car can be used to advantage without having sharp corners to turn. The silo should not be surrounded by buildings and pens in such a way as to interfere with filling. Obstructions hinder the work greatly, increasing the cost to the owner.

In most cases where the ground is soft, it will pay to carry the foundation down to a firm bottom, or to fill in with gravel. If it is impractical to go down to solid earth, the footings must be increased to at least twice the breadth recommended on page 55, and more if there is uncertainty.

In parts of the country where winters are very severe, there is an advantage in placing the silo on the south side of the barn, where it will be protected from the north winds. In the past quite a large number of silos have been built within the barn, but this practice is not recommended for several reasons. Such silos are inconvenient to fill, and silo odors are objectionable in the barn, for unless great caution is taken, the milk is apt to be contaminated by absorbing the odor.

Perhaps the most common fault made in locating silos is to get them too far away from the barn. In cases where this distance is made too great, the only way of remedying the situation is to build a room connecting the silo with the barn, thus incurring needless expense and increasing the distance to haul the silage. The distance from silo doors to barn need never be over 4 feet, which is sufficient for a chute of the ordinary size.

The corn should be cut while the stalks are still green, but after the lower leaves have begun to dry. At this stage the kernels have hardened or "glazed" on the outside, but are yet in the "dough" condition in the middle. If cut too green the silage will lack protein, sugar and other nutritive elements, and will contain an excess of moisture, generally making it sour. If too matured, it will be dry and unpalatable, with the fibre very prominent. In this condition it contains less nutriment, is relished less by the cattle, and is apt to mold or "fire-fang," causing it to be greatly damaged. Corn dried out in the shock makes poor silage unless put into the silo with plenty of water.



*Harvesting the Crop* The harvesting of corn or sorghum for the silo may be done by hand with the ordinary corn knife, but the corn harvester or binder is the implement almost universally used for this work. In some sections of the country corn has been cut with a sled equipped with saw-like knives projecting from both sides. Except where the corn has fallen down badly, as was the case in some sections of Michigan in 1910, the binder can be used to advantage. It not only saves time in cutting the crop, but also binds it into bundles which are easier to load on the wagon and feed into the cutter than the loose corn.

*The Cutter* Corn is sometimes placed in the silo uncut, but this practice is not to be recommended because the stalks will not pack closely, and the resulting air spaces cause excessive fermentation. The material is not as easily handled as cut silage, nor is it as economical to feed. The crop must be cut up fine for best results and when corn is used the entire plant, including ears, should be fed into the cutter. Although practice varies greatly, it is safe to say that corn for the silo should be cut one-half inch or even shorter.

*Elevating and Distributing* From the cutter the silage is elevated by a blower or conveyor, and deposited in a chute or automatic distributor. One or two men are required within the silo while it is being filled, to tramp down the sides close to the walls, and to keep it leveled off (thus preventing the formation of air pockets), and to mix the heavier portion of the silage with the lighter. Silage has a tendency to cling to the sides of the silo unless well tramped, and the heavier particles roll to the edges while the lighter remain near the discharge. The automatic distributor

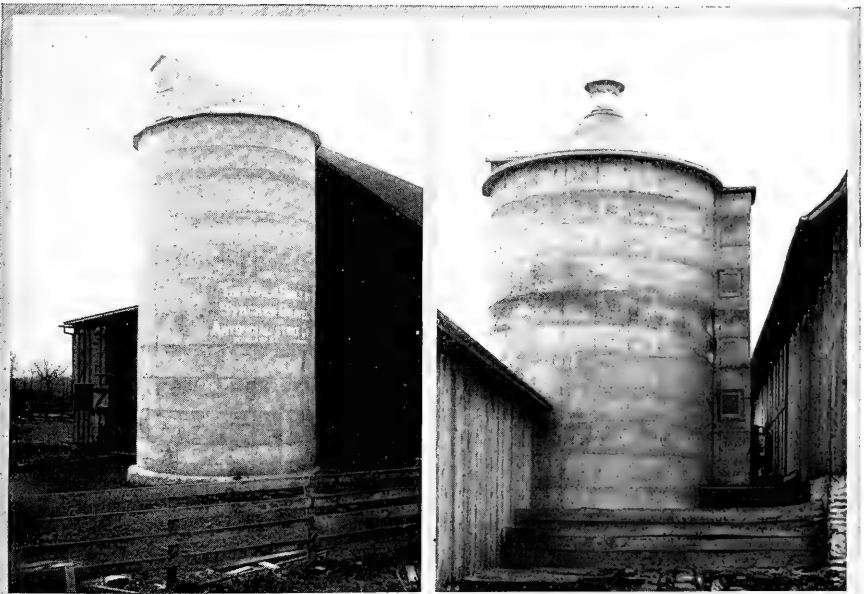

Silo on J. Mueller's farm near Highland. Dimensions 14 by 30 feet. Courtesy of Stocker Gravel & Artificial Stone Co., Highland, Illinois.

George Graf's Concrete Silo, inside dimensions 14 by 34 feet, near Pewaukee, Wisconsin. Note concrete roof and concrete chute.

greatly simplifies the work of filling the silo and does away with much of the tramping. The operator is simply required to guide the mouth of the tube, and the material descends with sufficient force to pack it nicely, making a minimum amount of tramping necessary.

*Economy of Filling the Silo Rapidly* It is common practice to fill the silo as rapidly as possible, that is, keeping the cutter and blower busy continually. This is the only economical method where the engine and cutter are rented, or hired labor depended upon. However, if these considerations do not enter in, there is no objection to filling the silo gradually, so long as fresh silage is put in before mold is formed on the surface of that previously placed.

During the process of filling all doors above the height of the silage should be left open for the purpose of letting out the carbonic acid gas which is given off and after the silo is completely filled it should not be entered for at least 48 hours.

*Wetting the Silage* When the filling is finally completed, the top should be wet down at the rate of about one gallon of water per square foot of surface, and thoroughly tramped. This aids greatly in compacting the silage near the top, reducing the depth of the spoiled material on the surface.

*Cost of Filling* Condition of crop, length of haul from the field to the silo, size of silo, method of harvesting and the cost and arrangement of labor are all elements which affect the cost of filling a silo. Farmers' Bulletin No. 292, Department of Agriculture, says: "In many cases a poor arrangement of help is responsible for extra expense. It

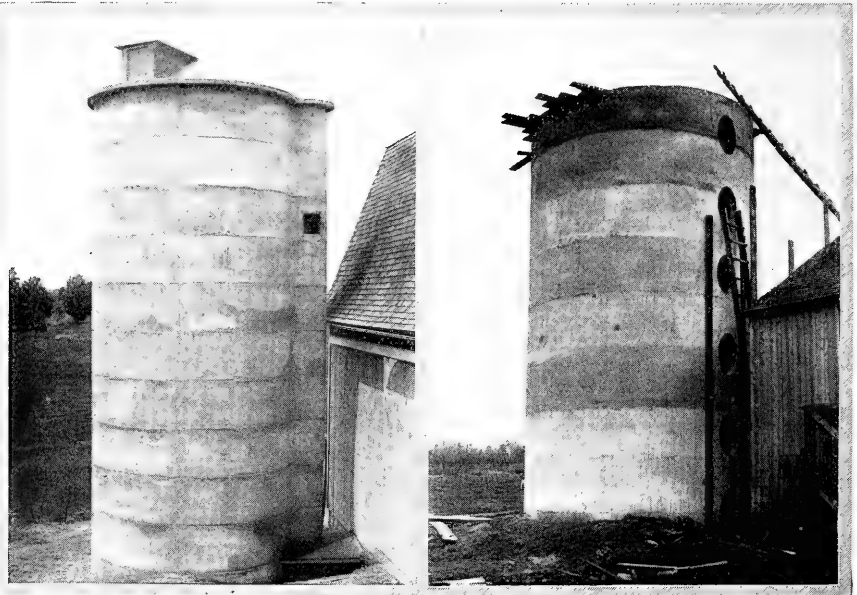

Concrete Silo on C. J. Float's farm, 12 by 36 feet, built by Conklin Contracting Co., Hartford, Michigan. Concrete silos are becoming popular in Michigan.

Home-made Concrete Silo on farm of George Wood, Woodville, New York. This is an excellent type of silo built by the owner, using commercial steel forms.

is not necessary for men and teams to be rushed to their fullest extent in order to get the work done cheaply. Some of the most expensive work was conducted with the greatest furore and hurry. The scheme where all are working and no one is hindered by the others, is the most economical.

The table on pages 102 and 103 shows the cost of filling 59 concrete silos during the season of 1910. Almost without exception the figures contained in these tables are considerably higher than usual, due to a poor crop of corn in most sections touched by the investigation and also to the peculiar condition of the crop in some sections of Michigan, where it fell down so badly as to make the use of harvesters impossible.

The average cost of filling 16 concrete silos in Illinois was found to be  $57\frac{1}{2}$  cents per ton; average of 22 silos in Michigan, 64 cents per ton; average of 10 silos in Wisconsin, 57 cents per ton; average of 4 Minnesota silos, 72 cents per ton; of 2 Ohio silos, 89 cents per ton; and of 2 Missouri silos, 50 cents per ton. The average cost of filling silos of 100 tons or less capacity was found to be 70 cents; 100 ton to 200 ton silos 58 cents, and silos over 200 tons 57 cents. The average for all the silos investigated was found to be 62 cents.

Recent investigations by the University of Illinois show the average cost of filling silos, including cutting crop in field, to be 58 cents per ton in Illinois, which figure compares favorably with the average of  $57\frac{1}{2}$  cents obtained in the investigation conducted by this company. Farmers' Bulletin No. 292 on the "Cost of Filling Silos," shows a range of 46 cents to 86 cents per ton on the 31 silos investigated, giving an average of 64 cents as against

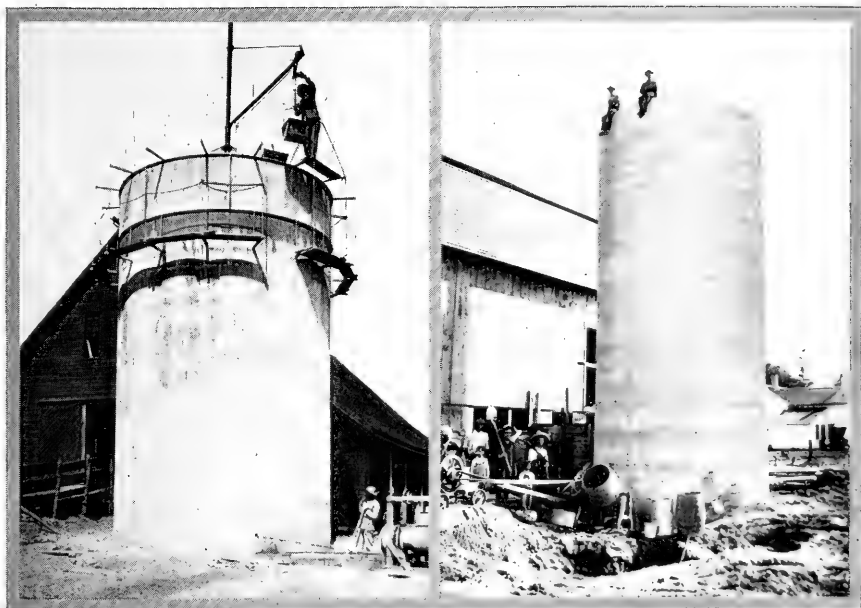

Cutting feed cost on L. V. Jurgensmeyer's farm at Homer, Illinois. Silo constructed by Chrisman Construction Co.

Wisconsin leads in cows and silos. Concrete silo on W. H. Butler's farm at Ripon, Wisconsin.

the average of 62 cents obtained in the investigation conducted by this Company.

The same elements which determine the cost of filling the silo, determine the total cost of the silage, with additional items including cost of the land, cost of tillage and interest on investment. Farmers' Bulletin No. 32 states that "In the writer's experience in the Central West the cost on high-priced land has been about \$1.50 per ton. F. S. Peer, in a recent book which treats of silos and silage, gives the cost in his experience as \$1.20 per ton. Professor Wall of Wisconsin places it at \$1.00 per ton to \$1.50 per ton, including cost of seed, preparation of land, interest on investment, cultivation of the crop, cutting and filling the silo. King, when studying this subject in Wisconsin, found that for a number of farms in that State, the cost averaged  $73\frac{1}{4}$  cents per ton."

Silage is always taken from the top of the silo, as obviously any opening in the bottom would admit air and cause the silage to spoil.

*Using off the Silage* The farmer, after filling his silo for the first time, will be astonished to see the amount of shrinkage; and the odor which greets him from the spoiled top layer may temporarily be discouraging. This layer of spoiled silage is unavoidable, even though salt is used in sealing, or whether oats or other grains are sprouted. The air will penetrate to a depth of a few inches if the silage is tightly packed and a couple of feet if loosely packed. That is why silage should be well

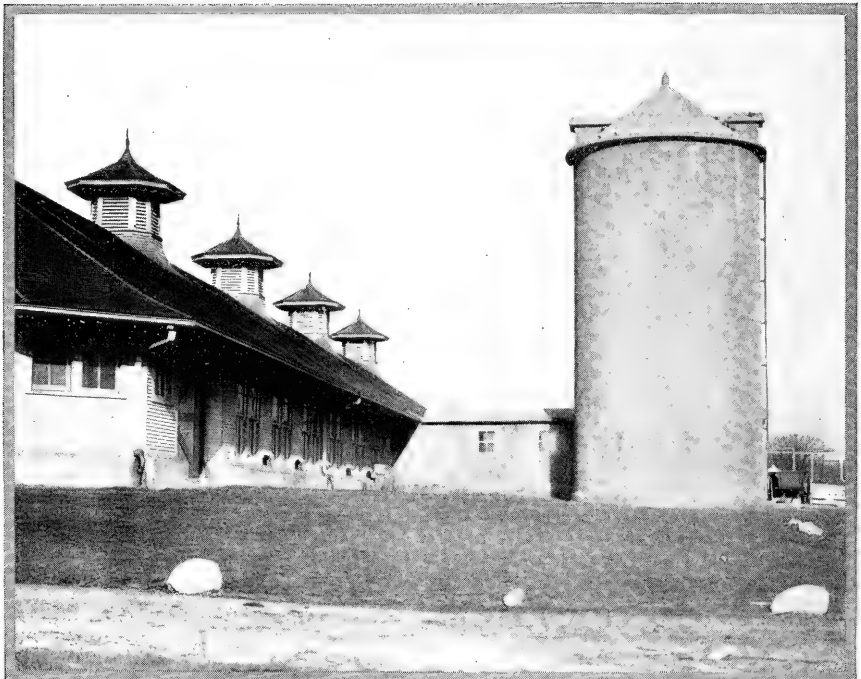

Concrete Silo at St. Charles, Illinois, Boys' School; erected by boys between the ages of ten and sixteen years.

packed down at the top. The spoiled layer must be thrown away and should never be brought near the barn, but should be dumped into the manure pit or else put into the manure spreader and carted off immediately to the fields, as the odor is disagreeable and the spoiled material is unfit for feed.

One tall, narrow silo is better than two short, wide ones; first, because there is only one top layer to spoil, and second, because shrinkage in the tall silo is little, if any, more than that of either of the two smaller. It is known that a silo 14 x 60 feet will have approximately twice the capacity of a silo 14 x 40 feet. This is because the silage in the tall, narrow silo is better compacted. Not only is there a saving because of only one top layer and a smaller percentage of shrinkage, but the silage in the bottom 40 feet of the tall silo is generally superior and more valuable because the air has been so completely excluded.

At least 2 inches each day must be fed off the entire top of the silo in order to prevent mold. Some authorities advise that the surface of the silage be kept level, but in the Northern States, it is customary to make the surface cone-shaped to prevent freezing around the edges.

Frozen silage should never be fed and can be best thawed out after the day's feed is thrown down the chute by scraping it from the walls and piling it in the center of the silo to thaw out.

Only as much silage should be thrown down the chute at one time, as is required at that specific feeding period. Otherwise, the silage will spoil and the feeder can blame only his own carelessness.

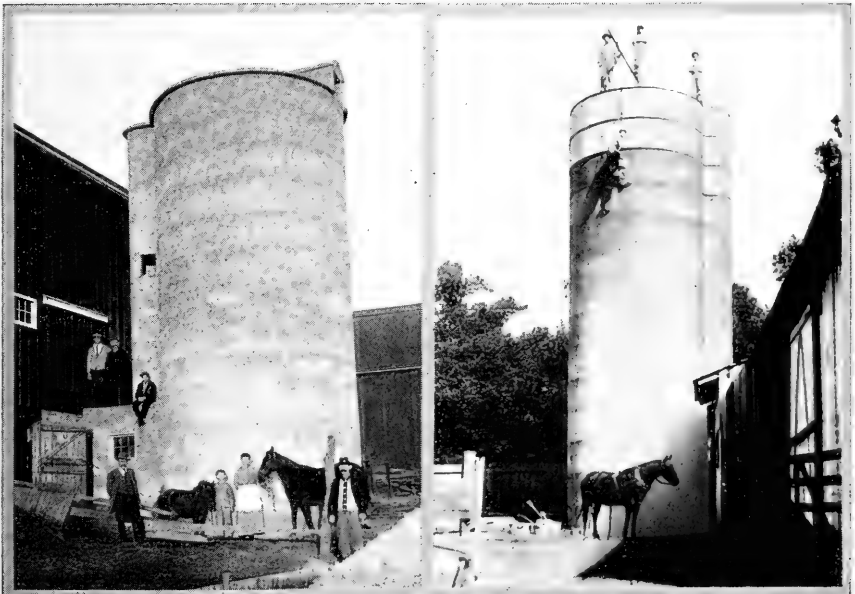

Concrete Silo, 14 feet by 35 feet, on Charles Dupuy's farm near Beaver Dam, Wisconsin, built by F. H. Reifsneider of Beaver Dam.

Tall Silo (inside dimensions 12 feet by 45 feet) on Illinois stock farm of Trimble Brothers, at Trimble, Illinois.

**C**ONCRETE conquers the farmer's greatest enemy — FIRE. Old wood barns may burn but the years feed is safe in a concrete silo. Concrete for the barn, too, is a logical step.

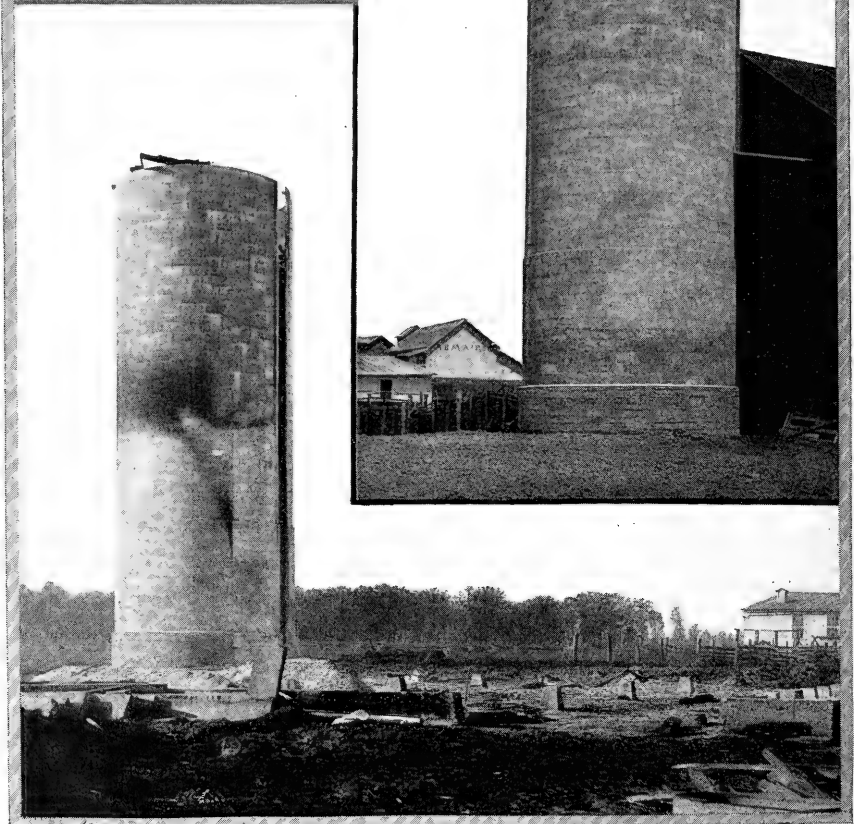

Before and After a Disastrous Fire on farm of A. B. Main, Delaware, Ohio; adjoining barn contained 180 tons of hay. Burned in Autumn of 1910; 530 tons of silage absolutely uninjured in silo, so that Mr. Main was not compelled to sacrifice 80 head of cattle which he was feeding at that time. The silo is 20x60 feet in size and was built by the Perfect Cement Silo and Cistern Co., Delaware, Ohio.

## The Advantage of Concrete as a Silo Material

It has been admitted by those who have studied the subject from an impartial standpoint, that silage can be kept in good condition in a silo of any material—be it concrete, stone, tile, or wood—if the material selected is properly used and the walls remain air tight. The length of time for which the silo will continue to fulfill in a satisfactory manner the service required of it depends, however, upon the selection of the material best able to combat the action of the elements, withstand the heavy strains due to the weight of the silage, and furnish reserve strength for such extraordinary conditions as fires and cyclones.

Concrete—whether placed in forms cast in blocks or slabs, or applied to a metal frame as cement mortar—is the ideal silo material because it is permanent, wind-proof, rodent-proof and fire-proof, and is economical in first cost and maintenance. As regards permanency, there is no question but that a good concrete silo will remain indefinitely. Concrete grows stronger and tougher with age, outlasting almost every other known material. Reinforced concrete is the strongest and most enduring construction known. It is selected for the great engineering projects—long bridges, massive dams, and lofty skyscrapers.

One of the special advantages of a concrete silo is the fact that it is just as wind-proof and fire-proof when empty as when filled, and always retains its maximum strength regardless of whether full or empty. An investigation made by the Universal Information Bureau immediately after the terrific wind storms which swept the United States during March, 1913, failed to reveal a single monolithic or concrete block silo damaged by the storms. The development, during the past ten years, of slender reinforced concrete chimneys of great height, shows that from a standpoint of safety against wind resistance, this type is unequaled.

Mice have been known to cause considerable loss by burrowing into wooden silos. Mice holes allow the air to get in, often causing the silage to spoil for a foot or more in all directions from the holes. Mrs. L. H. Adams, of Parma, Michigan, had an experience of this sort, and as she has a concrete silo of the same size adjoining the stave silo, a fair comparison between the two is easily made. The loss of silage from mice holes in the wooden silo brought the total loss in that silo up to more than twice the loss in the concrete silo, notwithstanding the fact that the latter was not provided with roof, chute, or doors, the continuous door openings being roughly boarded up.

Concrete silos prevent silage from drying out. The old idea that the juices of the corn seep through concrete walls with bad effect upon the latter has been entirely disproved—in fact, it never has been entertained for a minute by owners of concrete silos. The bugaboo of a concrete silo disintegrating through the action of corn acids is an absurdity. There are hundreds of cases where the concrete bases and floors of wooden silos have been in use for a long term of years without discoloring or disintegrating in the least, showing conclusively that silage acids have no effect.

## Fireproof Construction

The farmer, of all people, is at the mercy of fire. Let a blaze once start in or about his barns and the chances are small for saving any of the surrounding structures. Fire fighting apparatus is out of the question, the water supply is generally limited, and in nine cases out of ten, help cannot be summoned until the flames are beyond control.

Silo fires usually cause great loss because the feeder of silage is entirely dependent upon his silo all through the feeding season, which covers the greater part of and sometimes the entire year. The loss of the silo frequently means that the cattle have to be sold off, always at considerable sacrifice. Concrete silos of either the monolithic or block type are absolutely fireproof—of such a construction that they might be used for chimneys. If equipped with a concrete chute the concrete silo will protect the silage perfectly, and in the event of a fire not a pound need be lost.

During the winter of 1910 fire destroyed the barn of George Pulling, near Parma, Michigan, adjacent to which was Mr. Pulling's new 85-ton monolithic silo, erected at an expense of \$300. This silo, one of a large number of similar ones put up in that part of the country by Mr. Charles Nobles, of Kalamazoo, came through the fire in good shape, with silage in perfect condition. At the time of the

*George  
Pulling's  
Silo*

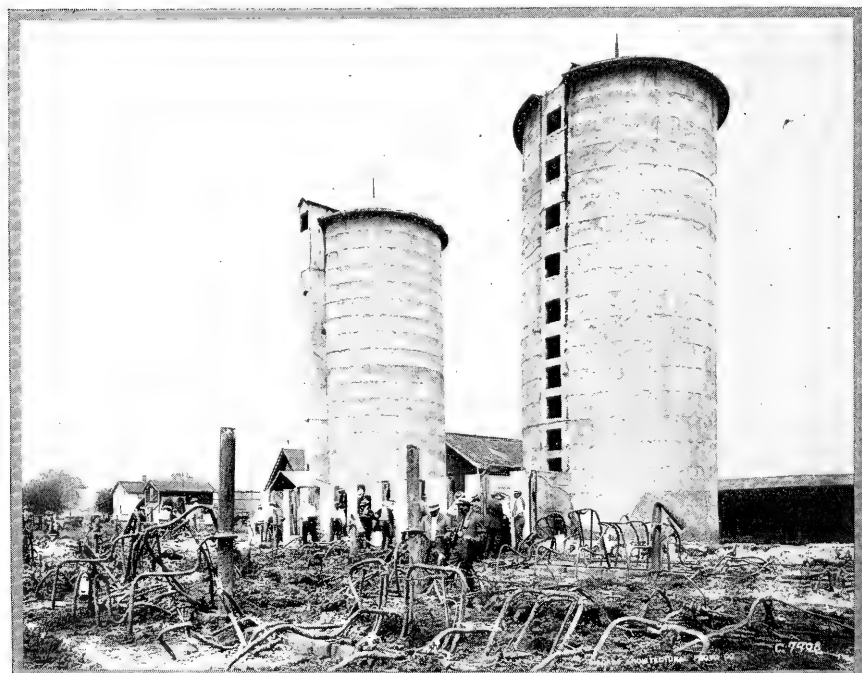

Concrete Silos on Dunham Farm, Wayne, Illinois, which successfully resisted a disastrous fire which destroyed the adjoining dairy barn in the summer of 1913.



fire the silo contained about 50 tons of corn silage, and as hay was then selling in the vicinity for \$15 per ton, dry feed to take the place of the silage would have cost probably \$500, an amount greater than the cost of the silo and silage combined.

A striking example of the value of fireproof silo construction is presented in the illustrations on page 44, showing the 550-ton concrete block silo of Arthur B. Main, Delaware, Ohio, before and after the disastrous fire which destroyed his barn in October, 1910.

*A. B. Main's  
Silo*

This silo was built for Mr. Main during the summer of 1909 by the Perfect Cement Silo & Cistern Co. of Delaware.

At the time of the fire Mr. Main was feeding between 80 and 90 head of cattle and had on hand 530 tons of corn silage and 180 tons of hay, the latter being stored in the end of the barn adjacent to the silo. The barn burned to the ground, leaving nothing but the concrete footings, which will be noticed in the lower illustration.

Although the silo was subjected to intense heat, the only damage done was the burning out of the continuous wooden doors. Perhaps the most remarkable fact brought out in connection with the fire was that of the small amount of silage lost. After the destruction of the doors the surface of the silage presented to the flames was seared and charred to a slight extent, but the charred or spoiled layer had a thickness of less than half an inch, and the amount actually lost was insignificant.

Had Mr. Main been deprived of his silage by fire, it is safe to say that his dairy business would have been ruined, temporarily, at least. At the

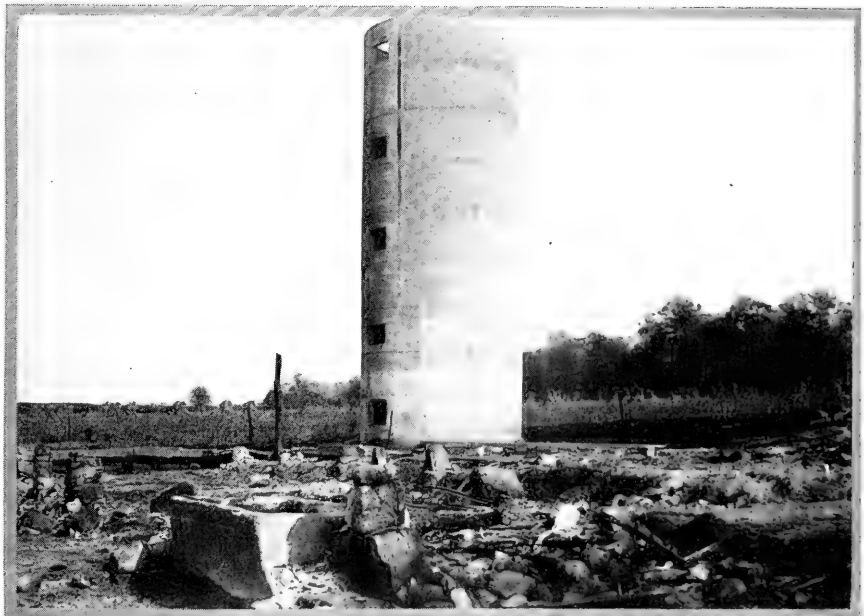

McCoy Silo near Harrisburg, Pennsylvania, unhurt by disastrous fire which completely destroyed the barn and other buildings. Photograph was taken ten days after the fire; proves the fire-proof qualities of concrete.

time of the fire hay was selling at \$15 per ton. Had it been possible for him to have substituted a daily ration of 40 pounds of hay per cow for the 40 pounds of silage and 10 pounds of hay being fed, the cost would have been no less than \$4,000. Mr. Main could not, however, have purchased the dry feed with which to have fed his herd through the season; even had that been possible, the hauling of a sufficient quantity of dry feed a considerable distance over bad roads would have been impractical, according to his statement. The only course left open would have been to dispose of his cattle, which would have meant a large loss.

The cost of Mr. Main's silage was estimated at \$1.12 per ton, or a total of \$593.60. The silo cost \$750 complete. The total cost, therefore, of silo and silage as they stood at the time of the fire was about \$1,343.60. Had the silage been destroyed, the cost of substituting dry feed would have amounted to about three times the cost of the concrete silo and its contents. These figures are sufficient to convince the thoughtful farmer of the desirability of putting up fireproof silos.

The reinforced concrete silos shown on pages 46 and 47 successfully resisted disastrous fires and the silo on page 48 successfully resisted a cyclone. The silos on the Dunham farm were exposed to a very severe test, as a wooden dairy barn adjoining burned when the entire second story was full of hay and other combustible material. The fire rushed up the empty silo to the right of the picture, which was not protected with a chute, and the flames roared out the top, making a huge chimney of this silo. Concrete withstood this extreme fire test, however, and the silos were ready for use as soon as they had cooled off from the heat.

The McCoy silo shown on page 47 successfully resisted a severe fire which destroyed the barn and all other buildings, hardly a trace of which remained, as shown in the illustration.



After Cyclone of July 26, 1913, at Frankfort, Kentucky. Eighty-one large barns were blown down. This Polk System concrete silo was undamaged, nor were other concrete silos in the vicinity harmed. "They are not built of pieces and they cannot go to pieces."

The wreckage scattered around the silo illustrated on page 48, after the cyclone, proves conclusively, without argument, as to whether or not concrete stands after severe wind storms.

Properly reinforced concrete silos will not be injured by lightning; in fact, different concrete silos have been struck by lightning, and if it were not for the statements made by reliable eye witnesses, no one would believe that the silos had been struck. A possible explanation of this is, that the lightning runs down the reinforcement into the ground and where a concrete roof and concrete chute are provided, there is no opportunity for lightning to enter the structure.

*Practically  
No Wasted  
Silage*

All available data tend to show that the waste of silage in silos built of concrete is fully as small, if not smaller, than in silos of any other material. Of 50 silos in the states of Illinois, Michigan, Wisconsin, Indiana, Ohio, Kentucky and Missouri, on which reliable data were obtained, 25 showed a loss of less than one-half ton of silage from all causes, 18 showed a loss between one-half ton and two tons, and 7 showed a loss of more than two tons. In terms of percentage of the total silage in each silo, it was found that thirty-four had an annual loss of less than one per cent, thirteen had a loss between one and three per cent, three had a loss greater than three per cent. The greatest loss in any case was about six per cent.

These figures are somewhat lower than those recorded at some of the state agricultural colleges, probably for the reason that the college dairy-



Twin Silos, 14 feet by 40 feet, built for W. Swart of Plymouth, Wisconsin, by W. H. Limberg, silo contractor and inventor of the Limberg Concrete Silo Molds.

men are more particular than the average farmer, rejecting silage which the latter would consider fit for use. It may be stated conservatively that with silage crop in good condition when put in, properly tramped down and fed out at the rate of 2 inches or more per day, the loss in concrete silos of either the monolithic or block type will seldom, if ever, reach 5 per cent.

*The Effects of Freezing* The subject of frozen silage has attracted considerable attention, more perhaps than its just due. The fact has been pretty well established that freezing is an inconvenience rather than a real detriment. Silage which has been frozen has to be handled an extra time, being pitched to the center of the silo with the warmer silage to thaw. Silage keeps indefinitely while frozen, and instances are noted where it has not spoiled after thawing, when left packed in the silo.

After thoroughly thawing out, silage which has been frozen is equally as nutritious as before freezing, and the cattle eat it with as great relish. Silage in the frozen condition is liable to produce harmful effects, and should never be fed. "All careful stockmen heat their drinking water," says Wisconsin Bulletin No. 125, "but it is a much more serious matter to feed a cow 40 pounds of silage at 32 degrees than to give her 20 to 30 pounds of ice water."

*Concrete Silos Successful in Coldest Climates* In northern Minnesota and North Dakota, where the temperature frequently reaches 30 degrees below zero during the winter, and occasionally goes as low as 40 degrees below, monolithic and concrete block silos are in successful use. A recent investigation of concrete silos in Minnesota failed to disclose any in which the silage froze more than one foot back from the wall on the north side. Freezing to this extent occurred when the temperature was between 30 degrees and 40 degrees below zero.

Prof. J. H. Shepperd, dean of the North Dakota Agricultural College, says in a recent letter:

"I might say that our experience here indicates that there is no difficulty in putting up the ordinary type of silo in this state by reason of the cold weather which occurs during the winter season. Our farmers who have had experience with them recommend building them outside of the barn rather than to put them inside to protect them from heavy freezing of the ensilage on the walls. I think there will be a large increase in the number of silos in this state in the next few years."

Prof. A. D. Wilson writes as follows, to the Minneapolis Cement State Silo Company:

*Roof Prevents Freezing* "Observation of a large number of silos during the severe winter weather of 1912 has convinced us that the walls haven't a great deal to do with the freezing of silage. \* \* \* \* The only silos of which we know that did not freeze were those having tight roofs and in which all of the doors were kept closed. There is evidently heat enough in ordinary silage to largely prevent freezing if the warm air generated from the silage can be kept in the silo."

The average time required to construct a monolithic silo is from 10 to 21 days, depending upon the height, number of men on the job, con-

*Time  
Required  
to Build  
Concrete  
Silos*

ditions of weather, and the height of wall accommodated by the forms at a single filling. Where the work is done by home labor occasionally more than 2 weeks are required. The block silo can usually be put up in 4 days to a week, depending upon its size and the number of block masons employed. After completion it should be allowed to stand at least two weeks before filling, to allow the mortar to become firm and hard. Cement stave silos are commonly erected complete in 3 days, and cement plaster silos in about a week. If the silo is to be filled during the early part of September, work on the foundation should be commenced no later than August 20th. In all cases the silo should be completed two weeks before being subjected to the strain caused by filling.

*A  
Comparison  
of the  
Monolithic  
and Concrete  
Block Types*

Two general methods of concrete construction are available for silo work—the monolithic and the concrete block. With the former method, the materials are hauled to the site of the silo and there mixed and placed within forms; the latter method requires that the block be made and cured in some convenient place, and later hauled to the site to be laid up in the wall.

Each method has certain advantages and disadvantages, but the matter of personal choice generally influences the decision to build either with monolithic walls or with block. The monolithic silo is generally the easier of the two for inexperienced persons to build, and is usually a little cheaper than the block, as it does not require the service of good masons or the use of a block machine; the block silo, however, makes the use of forms unnecessary, produces a wall with continuous vertical air spaces, and slightly reduces the amount of materials used.

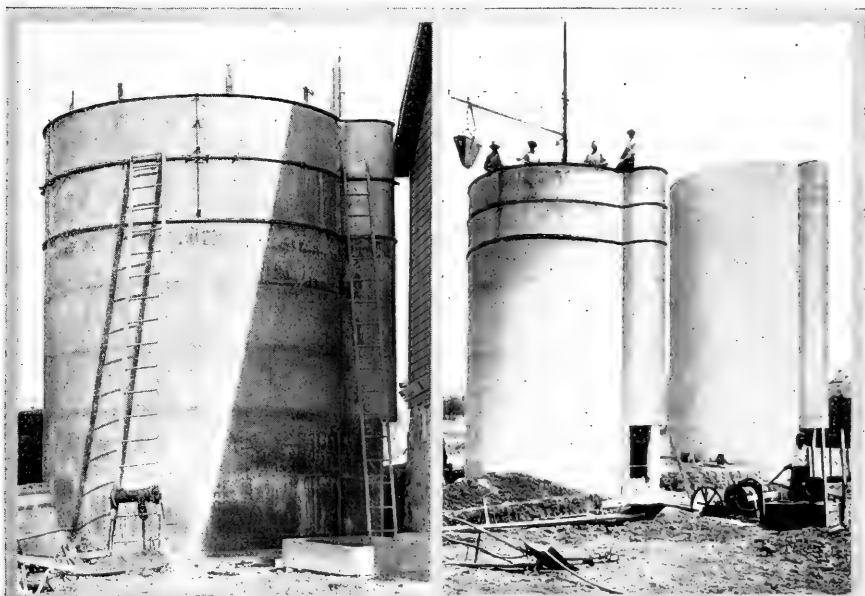

Andrew Smith's Concrete Silo. No trouble here with freezing.

Silo on Government Reservation at Chilocca, Oklahoma.

## Building the Concrete Silo

Where the services of reliable concrete silo contractors can be obtained, it is generally advantageous to have the silo built under contract.

### *Contract Work*

The cost of silos built in this manner is generally no more than otherwise, when quality of the work, convenience and time are considered. The advantages of good system, competent over-seeing and general experience in the work justifies a greater cash outlay than is needed for home-made silos, although in a great many cases the actual expense of a silo built under contract is no greater than if built by the owner. If it is desired to put up the silo during a time of year when work is over-plentiful or farm labor scarce, building the silo under contract will solve the labor problem. Cement stave silos are built under contract exclusively, by lessees holding territory rights from the owners of the Playford cement stave patent rights.

Of 110 concrete silos recently inspected, 74 were built by contractors, 9 by the owners under experienced foremen, and 27 by the owners without any assistance whatever. In over one-half of the cases where the silo was built under contract the owner furnished a part of the labor, and in about one-fifth of the cases the owners furnished the cement. Almost without exception, the owners of contract-built silos furnished the sand and gravel, for which they received credit on their accounts, at a stipulated rate.

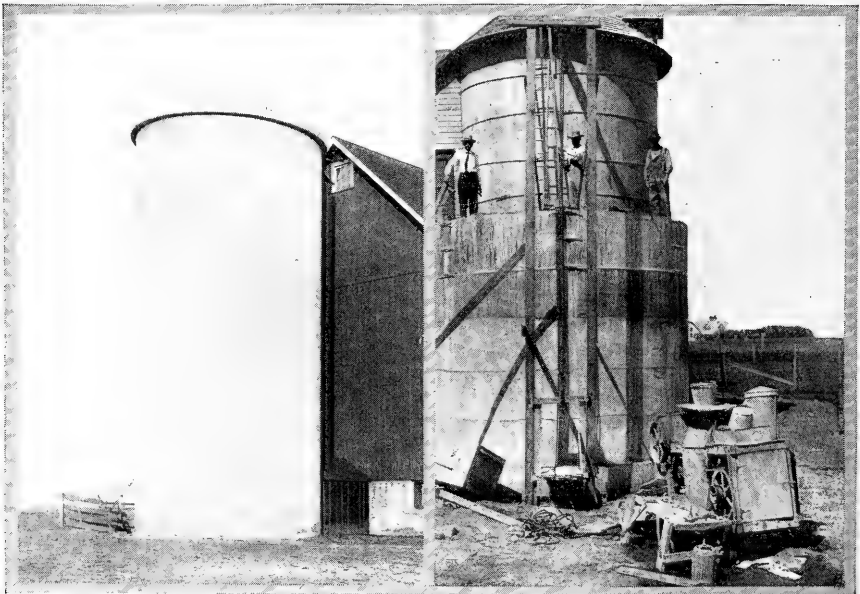

Concrete Roof constructed with Warford's forms. Silo on George Harvey's farm near Batavia, Illinois.

Monolithic Concrete Silo in Process of Construction by students of South Dakota State College, Brookings, South Dakota.

In a large number of instances farmers have built their own silos under the supervision of a competent foreman hired by the day. Foremen who make a business of superintending silo work frequently have their own forms which they rent to the farmer for a nominal sum. When the silo is built under contract, the farmer usually does the hauling and sometimes furnishes the materials and a part of the labor; when a foreman is employed, the farmer must buy and haul the materials, furnish the labor, and pay for the work as it progresses, without an accurate previous knowledge of the cost. In addition he sometimes has to build his own forms.

If neither a good contractor nor a good foreman is available, the farmer may undertake the building of the silo, but he must pay close attention to the details of the work. The inexperienced worker with concrete too often considers cement a sort of magic material which may be used without precaution and still secure first class work. On the contrary, precautionary measures are constantly necessary and the directions given on the following pages must be carefully complied with if the best results are to be obtained. To acquaint inexperienced contractors as well as those desiring to build their own silos with the best practice, is the purpose of the two sections immediately following. A later section is devoted to a description of several of the leading commercial silo forms now upon the market.

Where there are several silos to be built in the immediate vicinity, and it is desired to use home-made forms and do the work with home labor, a very considerable saving can be made by co-operation. With moderately fair weather, such as usually prevails from April to October, four or five farmers working together can construct one moderate size silo in an average time of less than two weeks, working but 4 hours per day, with one set of forms. In about two months' time they can complete a good silo on the place of each, without having this work interfere seriously with general farm duties, and at a comparatively small expense, as only one set of forms is used.

There is no doubt but that time, labor and money can be saved by farmers through organizing concrete silo clubs. Where organizations like Farmers' Clubs, The Grange, etc., exist, members of such societies can undoubtedly combine and by hauling the materials co-operatively and purchasing them from local dealers in carload lots, the best prices can be obtained and a minimum amount of time and labor occupied. Neighboring farmers may unite in the purchasing or renting of silo forms, silo cutters and fillers, and in the purchase of similar materials.

"During the past season, five farmers in Barnes County, N. D., co-operated in the building of concrete silos on their farms, buying their material in one lot, which alone made a considerable saving. Then they used two sets of forms, moving the crew from one silo to another, so that there was no time lost in waiting for the concrete to set. They also bought a silo cutter and filler for their combined use, so that by assisting each other in filling the silos the expense is reduced to the minimum. This is an example that can profitably be followed in every part of the Dakota Farmer Empire."—*The Dakota Farmer, Aberdeen, South Dakota.*

## Foundations

The site of the silo having been selected and its size determined, the excavation should be laid out. This may be done conveniently with a sweep similar to the one shown on this page. A heavy stake is driven in the center of the place selected for the silo and allowed to project above the surface about 1 foot. The arm of the sweep

*Laying Out  
the Work*

may be made of a two-by-four at least 2 feet longer than one-half the inside diameter of the silo. The arm swings about the stake as a center, being held to the latter by a large spike. A chisel-shaped board or template is placed as shown on the arm of the sweep, so that when the latter is swung around the stake, the chisel-shaped board will describe a circle with a diameter  $2\frac{1}{2}$  feet greater than the inside diameter of the proposed silo. This will give the outer line of the excavation and also foundation.

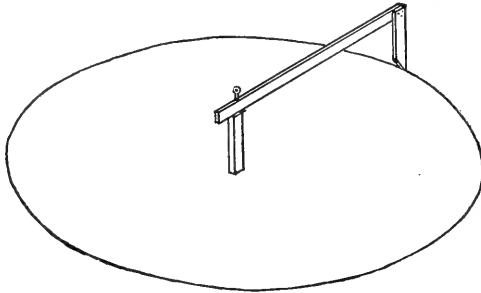

Simple sweep, convenient in laying out excavation.

The excavation should be carried to a depth not to exceed 6 feet below the floor of the barn where the silage is to be fed. The objection to going deeper is that it adds to the labor in removing the silage. In all cases, however, the foundation should be established below frost. All of the earth within the line described by the sweep should be removed down to a point one foot from the bottom, and below this the excavation should be made the shape and size of the foundation, 2 feet wide by 1 foot in depth, so placed that the outer edge will come directly up to the edge of the excavation, assuming that the sides of the latter are perpendicular.

*Excavating*

If the silo is to be equipped with a concrete chute, the foundation for the chute should be put in at the same time as that for the silo. As the chute is rectangular in shape, no difficulty should be encountered in excavating for the foundation, which will be at the same depth as the silo foundation, and 2 feet in width by 1 foot in depth.

The concrete for the foundations should be made in the proportion of one sack Portland cement to 3 cubic feet of coarse sand, to 5 cubic feet of screened gravel or crushed stone. The sand should be free from clay or organic matter, and the gravel or stone should contain no particle smaller in size than  $\frac{1}{4}$  inch. The materials



must be thoroughly mixed and enough water added to give a quaky consistency. The concrete may usually be placed in the excavation without any forms whatever, but in some kinds of soil light boards, held in position by stakes, may be necessary. The top of the foundation must be levelled off with a straight edged board and spirit level. After 24 hours, the foundations will generally have hardened sufficiently so that the walls may be built upon them. Where soft ground or quicksand is encountered, the foundation may be made 3 or 4 feet in width, to provide plenty of footing.

If a monolithic silo is to be built, the vertical reinforcing for the walls, consisting of 1/2-inch round rods spaced 3 feet apart, should be imbedded in the foundation a distance of 8 or 9 inches. If a block silo is to be built no vertical reinforcing need be placed.

*Table of Materials for Silo Footing and Floors*

Inside Diam. of Silo in Ft.	1:3:5 Concrete Cu.Yds.	Footings			4 in. Base 1:2:3 Concrete Cu. Yds.	Floors			Footings and Floor		
		Quantities				Quantities			Quantities		
		Cement Bbbs.	Sand Yds.	Gravel Yds.		Cement Bbbs.	Sand Yds.	Gravel Yds.	Cement Bbbs.	Sand Yds.	Gravel Yds.
10	2.44	2.83	1.27	2.10	.70	1.22	.36	.54	4.05	1.63	2.64
12	2.91	3.38	1.51	2.50	1.07	1.86	.56	.82	5.24	2.07	3.32
14	3.37	3.91	1.75	2.90	1.51	2.63	.79	1.17	6.55	2.54	4.07
16	3.84	4.45	2.00	3.30	2.04	3.55	1.06	1.57	8.00	3.06	4.87
18	4.31	5.00	2.24	3.70	2.64	4.59	1.37	2.03	9.59	3.61	5.73
20	4.77	5.53	2.48	4.10	3.32	5.78	1.73	2.56	11.31	4.21	6.06
22	5.24	6.08	2.72	4.51	4.04						

After the foundation is completed, the earth within should be dug out for a depth of about 8 inches, and a concrete floor built as shown below.

*The Floor*

The floor should be given a slight pitch in all directions toward the center, and, if necessary, an outlet to a line of drain tile should be put in. Outlets are not usually provided in silo floors, but in one or two instances silos have failed because of the pressure of a large

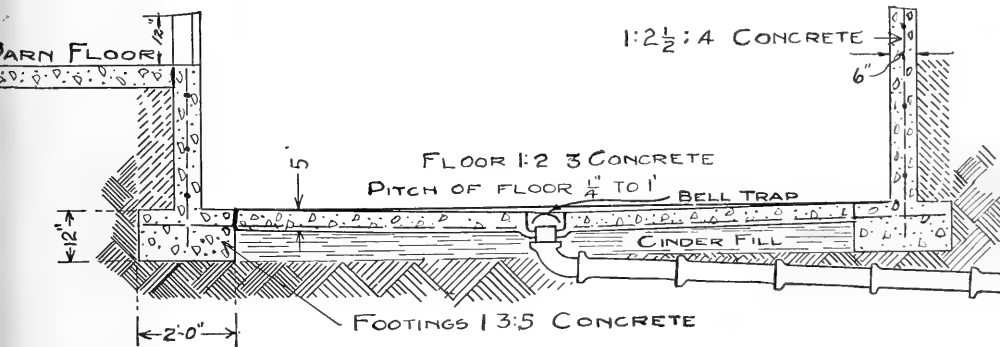

Concrete Silo Foundation or Footing and Concrete Floor, suitable for either monolithic or block silo, showing drain with bell trap; an important detail not to be needlessly overlooked.

quantity of water accumulated under unusual conditions, with no provision for escape. In such cases the stress on the walls may reach two or three times that usually imposed by the silage. Although the majority of silos are not provided with a drain, it is undoubtedly a desirable feature. The top of the drain should be protected from accumulations on the silo floor, by a small wire mat. A 4-inch or 6-inch drain tile will be sufficient. The floor should be made of 1:2:3 concrete. A smooth finish is not considered necessary.

## Home-Made Forms for Monolithic Silos

The word "Monolithic" coming from "mono" meaning one, and "lith" meaning stone, is used in concrete work to denote the objects of concrete which are one continuous solid mass or "as one stone." Contrasting with the monolithic are several systems of concrete construction such as the concrete block, concrete brick, concrete tile, unit column and slab, and cement plaster. The systems of concrete construction most commonly used are the monolithic and the concrete block. The object of the present section is to supply the necessary information for constructing monolithic silos, in cases where the work is all done by the owner who is dependent entirely upon his own resources, or by contractors not familiar with this class of work.

The form described and shown on the following pages is a combination of the Wisconsin form, designed by the Agricultural Department

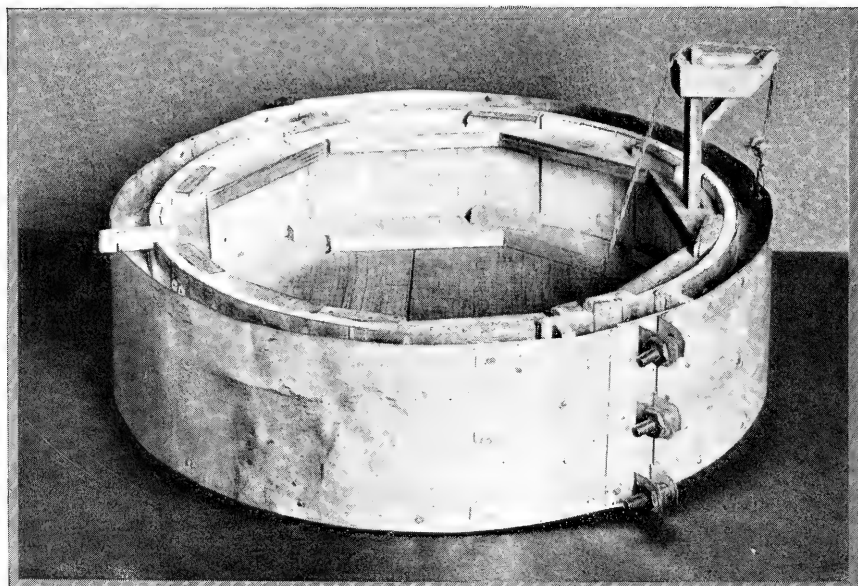

Farmers' Institute Silo Form used very extensively in Wisconsin and perfected by David Imrie of Roberts, Wisconsin.

**Home-Made  
Forms**

of the University at Madison, and the Farmers' Institute form, designed by Messrs. John and David Imrie of Roberts, Wisconsin. Both of these forms have been used with great success among the farmers of Wisconsin and adjoining states and appear to be in many respects the most practical forms yet devised. On the opposite page is shown a model of the Farmers' Institute form. The model was obtained through the courtesy of Mr. David Imrie, who has introduced this form to hundreds of farmers in conjunction with the work of the Wisconsin Farmers' Institute.

It is interesting to remember that there are more silos and probably more concrete silos in Wisconsin than in any other state in the union, and that today, Wisconsin leads in the value of dairy cows and the total value of their output.

**Description  
of Forms**

The list of materials for the inner form consists of sixteen segments or ribs made of sound 2x12 inch planks, sixteen cleats made of 2x16 inch plank, a number of 1x4 inch matched floor boards, a quantity of No. 28 gauge galvanized sheet iron, and sixty-four  $\frac{1}{2}$  inch bolts, 4 $\frac{1}{2}$  inches long. The dimensions of the ribs, which vary with the silo diameter, will be found in the table of materials given on page 62.

The first thing to do is to secure the materials necessary for the forms as given in the table. Make a compass or sweep of a plank or board with a spike attached to one end (for a center) and a crayon securely held at the other end (for a marker). The distance from the spike to the marker should be 1 inch less than one-half the diameter of the silo (distance "R" on table); for a silo 14 feet in diameter the length of the sweep should be

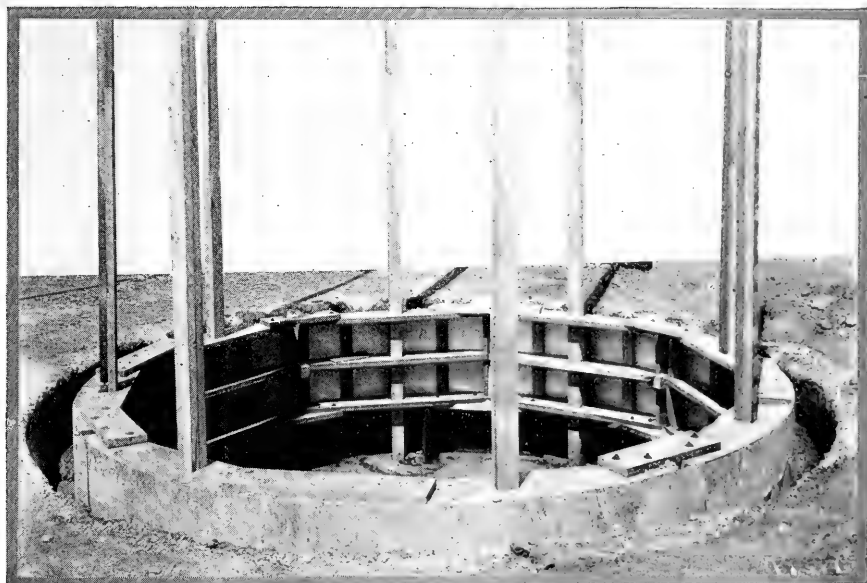

Second stage in using University of Wisconsin silo forms; illustrating the method of erecting scaffolding and holding it in place.

$\frac{1}{2}$  of 14 feet less 1 inch, or 6 feet 11 inches. To lay out the ribs for the inner form, lay 2x12 inch planks down upon the barn floor or other flat surface and mark the arc of the circle on each one with a sweep. The arc must be made tangent to the outer edge of the board. This arc gives the outer curved edge of the rib. Measure off the distance "C" (from table of ma-

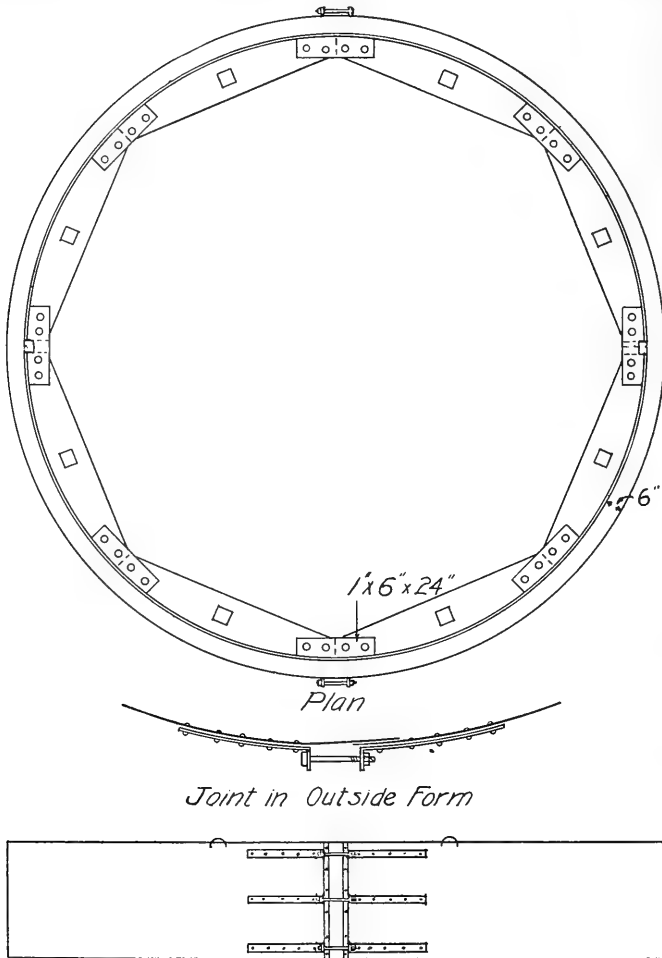

Plan of home-made wall forms, and details of outside form.

terials) along the curved edge of the rib, then mark off the ends of the rib in a radial direction using the sweep for a guide as it revolves around the center.

After the ribs are cut out along the lines indicated all that remains to be done is to drill the holes for the bolts by which the ribs are to be joined

together, and to cut a hole  $4 \times 4\frac{1}{2}$  inches in size in the center of each rib (see page 62), into which vertical members, consisting of two  $2 \times 4$ 's spliced together, must fit. Sixteen ribs make two complete circles.

The  $2 \times 6$ -inch cleats are made of  $2 \times 6$ -inch planks, cut off in lengths of 3 feet. The outer edge of the cleat is cut to the same circle as the outer edge of the ribs. Four  $\frac{9}{16}$ -inch holes should be drilled along the center line of each cleat to receive the  $\frac{1}{2}$ -inch bolts, by which each will be secured with the two adjoining ribs. The  $1 \times 4$ -inch flooring boards are sawed up into 3 foot lengths to make vertical surface boards for the inner form.

To assemble each segment of the inner form, nail the  $1 \times 4$ -inch flooring

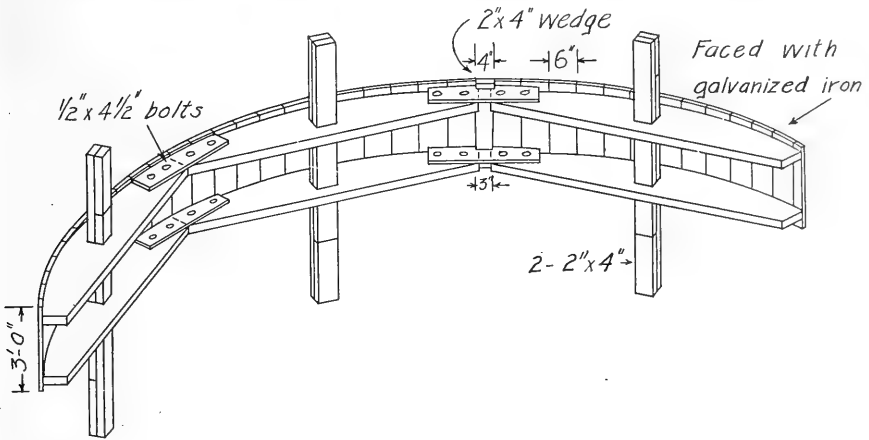

Perspective of Inner Wall Form, showing position of 2-inch by 4-inch uprights upon which the form is raised.

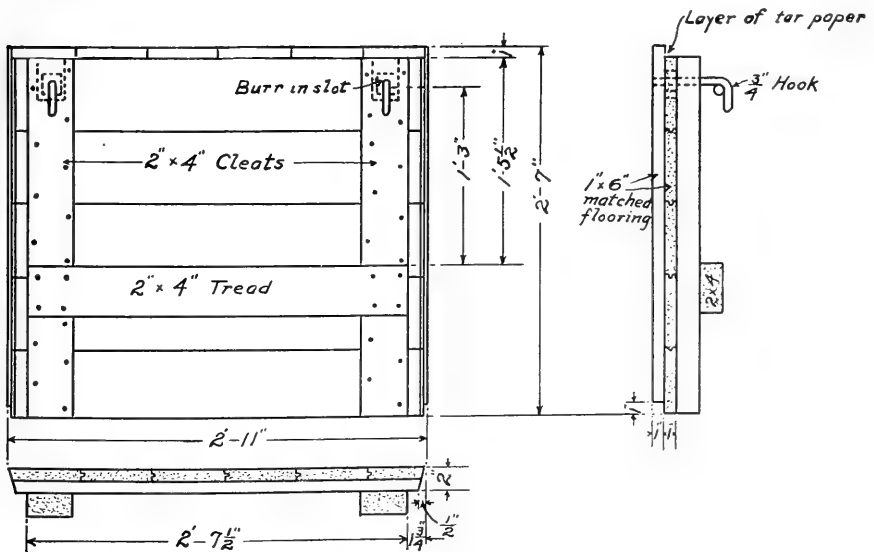

Two-ply Wooden Door for Continuous Doorway in either monolithic or concrete block silo.

boards vertically on the outer edge of the ribs, the latter being placed two feet apart center to center. This will bring the center of the lower rib 6 inches from the bottom of the form and the center of the other rib 6 inches from the top of the form. The floor boards should be securely nailed to the ribs. The surface will then be covered with galvanized sheet metal. Each of the eight segments may be made up in a similar manner and when bolted together, and if accurately made, they will form a true circle.

At two points in the circle the ribs and cleats should be cut to permit inserting wedges. The flooring boards must also be beveled to fit wedges 2x4 inches at the top, tapering to 2x3 inches at the bottom, as on page 59. After the segments of the form are bolted together, the wedges should be driven down. In removing the form, the wedges are first withdrawn and the segments then unbolted and loosened as much as necessary to make removal easy.

The inner form is provided with a very simple arrangement for supporting and also for raising and lowering. Through the 4x4½-inch holes centrally located in each rib, a 4x4-inch upright, made of two 2x4 inch nailed together, passes. One-half inch holes are drilled in these uprights at intervals of 2½ feet, corresponding holes on all of the uprights being at the same level. The form is raised 2½ feet each day. After raising to a new position the bolts are inserted in the holes directly under the bottom ribs of the form. As the work progresses upward, additional 2x4's are spliced on alternately.

The outside is made of heavy (No. 18 or 20 gauge) galvanized sheet steel, 3 feet in width. The form is made in two or more pieces, strips of

heavy band iron being riveted to the ends of each piece, the ends being turned out at right angles and provided with holes to receive the bolts by which adjoining sections of the form are drawn together. One-half inch threaded bolts 12 inches long are used. These strips are clearly shown, although somewhat exaggerated, in the illustration on page 56. A heavy iron handle is put on the outside form opposite each pair of 2x4-inch uprights to facilitate raising. This can be done with a simple derrick arrangement attached to the uprights.

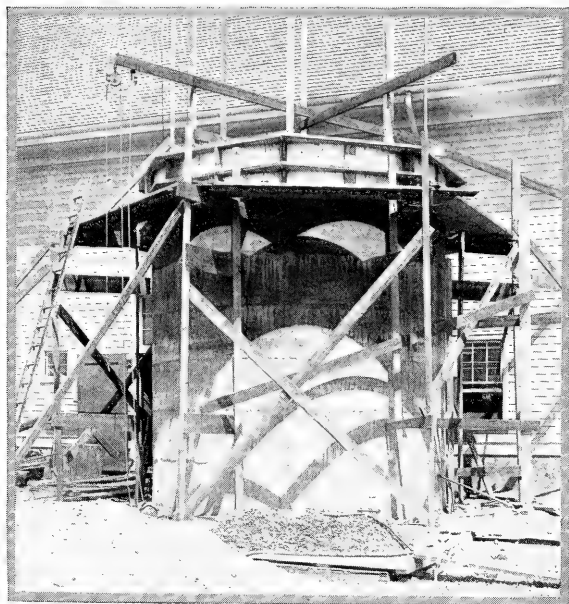

Third stage in the use of University of Wisconsin silo forms, showing method of building scaffolding, hoisting material and other essential details.

Forms of this type can be made for twenty-five to fifty dollars, and in one instance a farmer built an equipment similar to that described here at a cash outlay of only \$15. Forms can generally be disposed of after use at a price equal to the total cash outlay to the builder, so that the use of these in building his silo only costs him his labor. A single set of forms is often used on several silos, each user selling his forms to the next man for a sum slightly less than what he paid for them.

As the inner form is moved upwards it will be necessary to securely brace the upright supports. This is very essential. No weak or rotten lumber should be used, and all bracing should be put where it will carry the load in the best and most secure manner. The double two-by-four supports recommended have ample strength to carry the weight if properly braced, but this precaution must not be neglected.

The uprights should be braced at intervals of five feet (every two courses) with horizontal boards running from one upright to the next, and braced back against the wall as shown below. Boards 1"x6" or 2"x4" will be large enough for this purpose. About every 15 feet braces should be run across to opposite uprights, 2x4" or 2x6" material being used.

In handling the inner forms, great care must be observed in keeping the inside surface of the silo perfectly smooth. Horizontal "steps" in the wall are particularly objectionable. Projections, "steps" and other

**Cost of Forms**

**Care in Bracing Supports**

**Importance of a Smooth Wall**

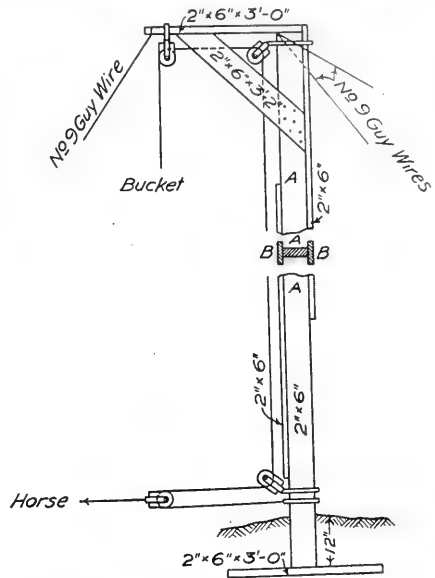

A Convenient and Easily Made Derrick for hoisting material. Design adopted from plans submitted by Iowa State College, Ames, Iowa.

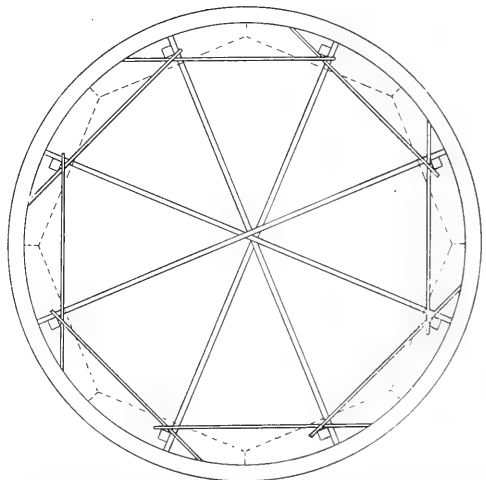

Illustration showing the method of bracing the upright supports on which the inner forms rest. Bracing between adjacent uprights is put in every 5 feet; those joining opposite uprights are put on every 15 feet.

irregularities cause uneven settling of the silage, thus forming air pockets. The presence of an air pocket frequently causes silage to spoil on all sides within a foot of the pocket.

The inner surfaces of the forms should be painted before using, with linseed oil, soft soap or equal parts boiled linseed oil and kerosene, which will prevent the concrete from sticking. This treatment is especially important where forms have wooden surfaces, but is also beneficial when applied to galvanized iron surfaces.

*Painting the Forms*

### *Materials for Home Made Silo Forms for Silos with Inside Diameters 10 feet to 22 feet*

16—2 in. x 12 in. plank	}	4 ft. long for silo 10 feet diameter
		4½ ft. " " " 12 " "
		5½ ft. " " " 14 " "
		6½ ft. " " " 16 " "
		7½ ft. " " " 18 " "
		8 ft. " " " 20 " "
		9 ft. " " " 22 " "

1 in. x 4 in. boards, for quantity see table.

16—2 in. x 6 in. cleats—3 ft. long, cut on radius "r."

2 in. x 4 in. studding planed. (Required quantity equal to 16 times the height of the silo.)

No. 22 Gauge galvanized sheet iron 3 feet wide. (For quantity see table.)

No. 18 Gauge galvanized sheet iron 3 feet wide. (For quantity see table.)

64—½-inch bolts 4½ inches long (for cleats).

8—½-inch bolts 12 inches long (under forms).

6—½-inch bolts 12 inches long (for outer forms).

4 Iron Straps ¼ in. x 2 in. x 3 ft. 0 in.

12 Iron Straps ¼ in. x 2 in. x 2 ft. 6 in.

Inside Diameter of Silo Feet	Dimensions of inner form ribs				No. of 1 in. x 6 in. Boards 3 ft. long in inner form	No. 18 gauge galvanized sheet iron 3 ft. wide		No. 28 gauge galvanized sheet iron 3 ft. wide	
	A	B	C	R		Ft. In.		Ft. In.	
	Inches	Ft. In.	Ft. In.	Ft. In.		Ft.	In.	Ft.	In.
10	8	3 3	3 10½	4 11	96	36	7	31	6
12	6¾	4 1½	4 7⅞	5 11	112	42	10	37	8
14	6	4 10½	5 5⅜	6 11	134	49	3	44	0
16	5	5 9	6 2½	7 11	152	55	6	50	0
18	4½	6 6½	7 0¼	8 11	168	61	9	56	6
20	3	7 4¾	7 9¾	9 11	192	68	0	62	10
22	2½	8 3	8 7¼	10 11	208	74	5	69	2

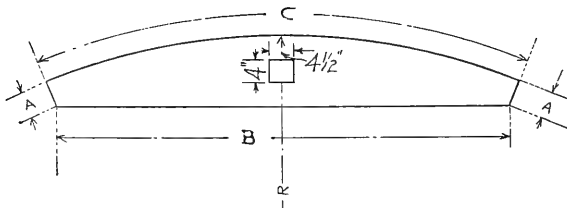

Inner form ribs.





The forms for casting the face of the jambs may consist of 2-inch planks of a width equal to the distance between the wall forms. Strips of 2x2-inch material should be nailed to the face of the planks so as to form 2x2-inch vertical recesses on the inside of the opening. Horizontal slots, to accommodate the ladder rounds, will have to be made in the planks at intervals of 18 inches. All surfaces of wood which will come into contact with the concrete should be planed and oiled, which will insure a smooth surface and prevent the wood from adhering to the concrete.

The distance between face of the jambs should be 30 inches and the jamb forms rigidly maintained in a vertical position and at proper distance apart.

Spacers consisting of 2x4's, at intervals of two feet, will hold the jamb forms apart rigidly and prevent them from bulging from the pressure of the concrete. The vertical jamb forms may be made in sections of any convenient length, preferably from six to twelve feet.

As soon as the silo wall has been brought up to the level of the barn floor the vertical wooden frames are placed in position, great care being taken to have them absolutely vertical.

The doors for the continuous doorway may be made of 2-inch planking, preferably tongue-and-grooved. The doors should be 34 inches in width and 30 inches in height. Five pieces of planking 6 inches wide, or 4 pieces 8 inches wide may be used conveniently. A  $\frac{3}{8}$ -inch hole is drilled on the vertical center line of each plank to accommodate the bolt and hook by which the door is held to the horizontal reinforcing across the door opening. The bolts used have a screw eye on the outer side to which hangs a hook made of heavy steel wire.

Non-continuous doors are perhaps easier to build than continuous doorways, and if the owners are satisfied that they provide sufficient room for getting the silage out conveniently, there is no objection to their use,

#### Non-continuous Doors

although on the other hand, they possess no great advantage over doors of the continuous type. The arguments often heard that the non-continuous door silo is a stronger type than the other, and vice versa, carry little weight, as either type may be made sufficiently strong.

Non-continuous doors are often put in with a distance of about  $2\frac{1}{2}$  feet between them, but the spacing may vary to suit the individual owner. In all cases the arches between the doors must contain an amount of reinforcing equivalent to the full amount

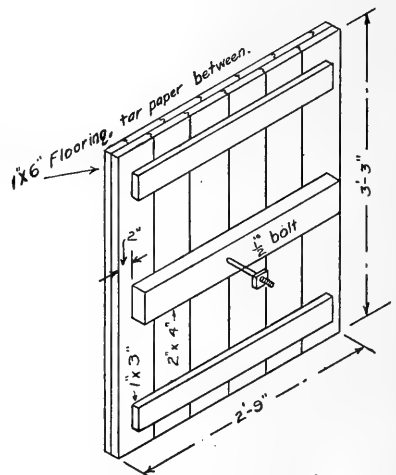

Non-continuous door, made of double layers of flooring with building paper between.

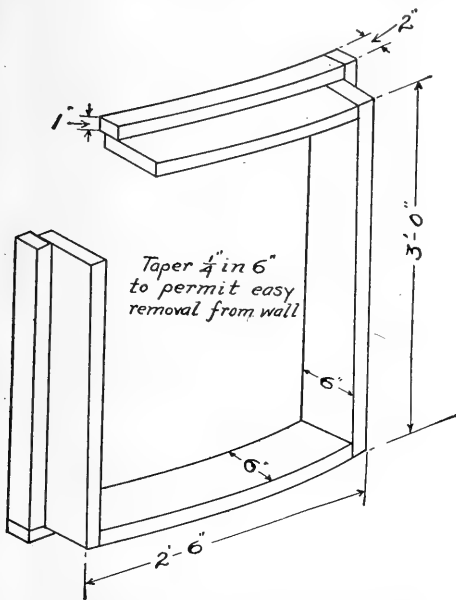

Wooden Form for non-continuous doorway.

of horizontal reinforcing put around the silo. Thus, if the doors are 3 feet in height, with a distance of  $2\frac{1}{2}$  feet between them, the horizontal reinforcing in the space between the doors should be equivalent in amount to that placed in  $5\frac{1}{2}$  feet of the wall where there are no doors.

On this page is shown a form for a non-continuous door opening. The bottom and top pieces are made of  $2 \times 6$ -inch plank cut to the arc of a circle with diameter the same as the outer diameter of the silo wall. The two sides are made of  $2 \times 4$ 's. A frame of lighter material is placed around the outside of the form for the purpose of making a recess two inches deep around the opening on the inner side of the wall, into which the door will fit. This frame is tapered to

ing. The bottom and top pieces are made of  $2 \times 6$ -inch plank cut to the arc of a circle with diameter the same as the outer diameter of the silo wall. The two sides are made of  $2 \times 4$ 's. A frame of lighter material is placed around the outside of the form for the purpose of making a recess two inches deep around the opening on the inner side of the wall, into which the door will fit. This frame is tapered to

fit. This frame is tapered to

permitted removal from the wall as soon as the concrete has hardened. It may then be used again for the next doorway above. If desired, a door frame of small angle iron may be used to protect the corners of the concrete. The frame should be slipped on over the form, and both frame and form then placed in position. The angle iron should be cut a few inches longer than the dimensions of the opening and the ends embedded in the concrete. The frame should also be anchored to the concrete by large spikes. Holes to receive the spikes should be drilled in the angles, 12 inches apart. The spikes should be bent at right angles to secure a better hold in the wall.

The doors may best be made of two thicknesses of  $1 \times 6$ -inch matched flooring with a layer of tar paper between. The  $1 \times 6$ -inch boards are held together by two  $1 \times 4$ -inch cleats across the top and bottom, and one  $2 \times 4$ -inch cleat across the center. The middle cleat is made larger than the others in order to take care of the strain caused by the large bolt in the center. A  $2 \times 4$ , 40 inches long, or a similar piece of material, is placed on the bolt, making a large "button" by which the door is held to the wall. The door is clearly shown on the opposite page.

**Doors**

One thing should be remembered by the farmer, the rural contractor and others who are constructing silos—that door jambs and the doors be so constructed that there is no exposed surface of steel against the silage. This is one reason why concrete jambs have been constructed, and are recommended as the best form of construction.

## Constructing Monolithic Silo Walls

As soon as the foundation has hardened under favorable conditions for at least two days the wall forms may be placed in position. Much care should be taken to locate them centrally and in such a manner that the sides are perpendicular. The 4x4-inch uprights should be carefully put in position at this time, being supported on wooden blocks or flat stones. After the inner form is in position, but before the outer form is placed, the horizontal reinforcing rods for the first three feet of wall should be wired to the vertical rods which were placed in foundation as previously mentioned. The outer forms should then be placed in position and tightened, with the small wooden spacers in place. Before placing the concrete, it will be necessary to clean off the surface of the foundation and moisten it thoroughly. The wall forms, having been previously painted with linseed oil or soft soap to prevent sticking, may then be filled with slushy concrete made in the proportion of one sack of Portland cement to  $2\frac{1}{2}$  cubic feet of coarse sand, to 4 cubic feet of screened gravel or crushed stone, all of the latter being between  $\frac{1}{4}$ -inch and  $1\frac{1}{2}$ -inch in size.

During the summer 24 hours are usually enough for concrete to harden before raising the forms, but in cool weather a longer time will be required. If the work be undertaken while there is danger of freezing, the usual cold weather precautions must be observed. In such cases the materials should be heated, or at least free from frost, and mixed with hot water. The

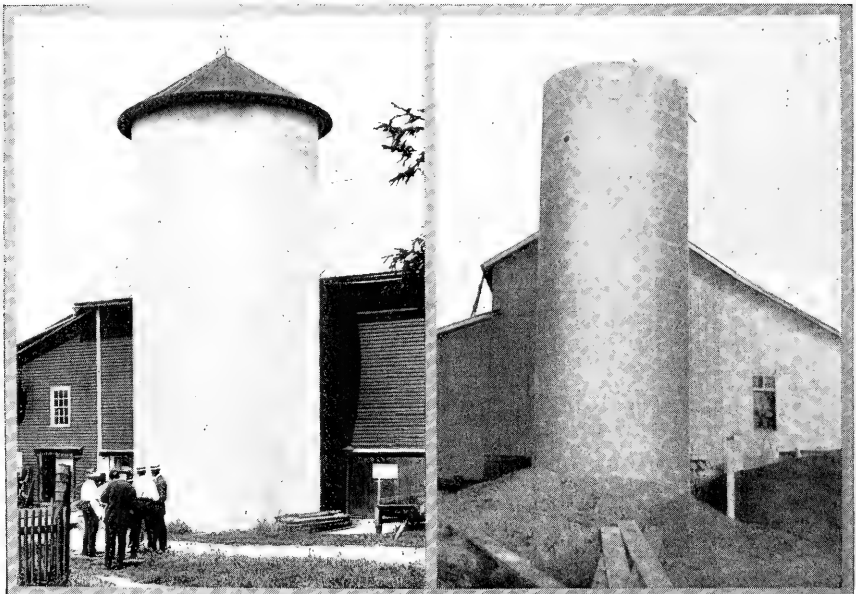

Concrete Silo built by W. H. Warford of Geneva, at LaFox, Illinois, for John Harvey.

Homemade Concrete Silo of Iowa farmers, C. N. Seurle and his son. Cost of material, \$86.

work in the forms must be protected for several days with manure, straw or a canvas jacket under which live steam is run.

The table below shows the approximate cubic yards of concrete required for the walls of monolithic silos of various sizes, with continuous doors, and walls 6 inches thick. The table on page 68 shows the quantities of cement, sand and gravel or stone required for silo walls, using proportions of 1 sack of cement to 2½ cubic feet of sand and 4 cubic feet of screened gravel or crushed stone. It can hardly be expected that these tables will be exact in all cases, as the difference in sand and gravel used, as well as other considerations, affect the quantities of materials to a considerable extent. These tables are accurate to within 10 per cent.

*Tables of  
Materials*

**Table Giving Cubic Yards of Concrete Required for Walls of Monolithic Silos with Continuous Doors**

For additional amounts required for Foundation, Chute and Roof, see Pages 55 and 89. Walls 6 Inches Thick

Height of Silo in Feet	INSIDE DIAMETER OF SILO IN FEET					
	10	12	14	16	18	20
26	14.68	.....	.....	.....	.....	.....
28	15.81	19.07	.....	.....	.....	.....
30	16.94	20.43	23.92	.....	.....	.....
32	18.07	21.79	25.52	29.24	.....	.....
34	19.20	23.15	27.11	31.06	35.02	.....
36	20.32	24.51	28.70	32.89	37.08	41.27
38	21.45	25.87	30.30	34.72	39.14	43.56
40	22.58	27.23	31.89	36.55	41.20	45.85
42	.....	28.59	33.49	38.37	43.26	48.15
44	.....	29.96	35.08	40.20	45.32	50.44
46	.....	31.32	36.68	42.03	47.38	52.78
48	.....	32.68	38.27	43.85	49.44	55.02
50	.....	34.05	39.86	45.68	51.50	57.32
52	.....	.....	41.46	47.51	53.56	59.61
54	.....	.....	43.05	49.34	55.62	61.90
56	.....	.....	44.65	51.16	57.68	64.19
58	.....	.....	46.24	52.99	59.74	66.49
60	.....	.....	47.84	54.82	61.80	68.78

To release the inner form, drive out the keys and if need be, remove a few of the bolts. Slide up the inner form on the upright supports and secure in the new position by the bolts passed through the supports just below the form, as previously explained. The inner form will then be bolted together again and the keys driven into place. After attaching horizontal reinforcing rods to the vertical rods for the second course, the bolts in the outer form are loosened and the form raised by means of ropes attached to wire handles and run-

*Moving up  
Forms  
for the  
Next Course*

**Cement—Sand—Stone—Required for Walls of Monolithic Silo**

Thickness of Walls, 6 inches. Continuous Doors, 2½ ft. wide. Proportions of Concrete, 1:2½:4

Height of Silo Ft.	Barrels of Cement required for given inside diameter in feet					Cubic yards of Sand required for given inside diameter in feet					Cubic yards of Gravel required for given inside diameter in feet							
	10	12	14	16	18	20	10	12	14	16	18	20	10	12	14	16	18	20
	26	20.41	26.51	33.25	35.47	40.64	48.08	7.49	9.73	11.11	13.02	14.91	17.86	12.04	15.64	19.61	23.98	28.72
28	21.38	28.40	35.47	40.64	48.08	57.37	8.06	10.42	12.20	14.64	17.86	21.05	12.96	17.88	23.53	29.97	37.16	45.12
30	25.55	30.29	35.47	40.64	48.08	60.55	8.64	11.11	13.02	15.45	18.91	22.22	13.89	19.61	26.15	33.78	42.93	53.84
32	25.12	30.29	35.47	40.64	48.08	63.73	9.22	11.11	13.02	15.45	19.96	23.38	14.82	20.93	28.47	37.60	48.99	62.64
34	26.69	32.18	37.68	43.17	48.08	66.94	9.79	11.80	13.83	16.26	20.06	24.56	15.74	22.33	30.41	39.48	50.68	66.40
36	28.24	34.07	39.89	45.77	51.54	70.11	10.36	12.50	14.64	17.71	22.06	26.89	16.66	24.85	34.46	45.12	58.85	76.40
38	29.82	35.86	42.12	48.26	54.40	73.29	10.94	13.19	15.45	19.52	24.16	29.33	17.89	26.80	37.60	49.97	64.92	85.40
40	31.39	37.85	44.33	50.80	57.27	76.48	11.52	13.89	16.26	21.01	26.89	32.86	18.52	28.33	40.54	54.96	72.97	97.60
42	33.00	39.74	46.55	53.38	60.13	80.13	12.11	14.58	17.08	21.57	27.66	34.91	19.57	29.44	42.93	58.47	78.42	104.40
44	34.66	41.64	48.76	55.88	62.99	83.29	12.71	15.28	17.89	23.11	29.33	37.60	20.33	31.38	45.12	61.96	83.85	111.60
46	36.37	43.53	50.99	58.42	65.86	86.48	13.29	15.97	18.71	24.44	31.57	40.92	21.57	33.78	48.99	66.40	91.60	120.00
48	38.12	45.43	53.21	60.95	68.72	89.20	13.89	16.67	19.52	26.89	35.47	45.12	22.86	36.61	52.64	72.97	99.60	130.00
50	39.91	47.33	55.41	63.50	71.59	92.42	14.49	17.37	20.33	29.33	39.48	50.68	24.16	38.99	55.40	76.40	104.40	141.60
52	41.74	49.24	57.63	66.04	74.45	95.60	15.11	18.06	21.14	31.57	42.93	56.40	25.72	41.96	61.96	83.85	111.60	154.40
54	43.61	51.15	59.84	68.58	77.31	98.04	15.74	18.71	22.06	33.78	45.12	60.13	26.89	44.97	66.40	91.60	120.00	168.00
56	45.52	53.06	62.06	71.11	80.18	100.80	16.39	19.46	22.77	36.09	48.99	66.40	28.47	48.08	72.97	99.60	130.00	182.40
58	47.47	55.03	64.27	73.66	83.04	103.60	17.06	20.16	23.53	39.48	52.64	72.97	30.41	51.54	78.42	104.40	141.60	200.00
60	49.46	57.04	66.50	76.20	85.90	106.40	17.71	20.86	24.40	42.93	56.40	78.42	32.86	54.96	83.85	111.60	154.40	220.00

ning over the little brackets on the uprights. When the outer form is raised to a position flush with the inner form, the lower bolt should be tightened until the form presses snugly against the wall; spacers should then be placed between the forms and the remaining two bolts tightened until the proper spacing is secured. The forms are then ready for the next filling.

*Joining  
Courses*

Immediately before the concrete is placed for each succeeding course, the surface of that previously laid should be thoroughly cleaned off and moistened, and coated with a cement and water grout of about the consistency of cream. This precaution is necessary to secure a good bond between the courses. It should be observed in all cases, as the pressure of the silage is apt to force moisture through any seams which might occur because of imperfect bond. Concreting should not be discontinued with a course partially completed, but if this is unavoidable the concrete surface should be left as nearly horizontal as possible.

*Height of  
Wall at Each  
Filling*

Although some forms are made 3 feet in height, the height of the wall built at each filling (after the first) will be 2 feet 6 inches, allowing the forms to cover 6 inches of finished wall when in position to be filled again. Experiments have shown that this is about the best height to fill at one time when using such forms, as it makes about one-half day's work for the average farm crew when the mixing is done by hand. In reasonably good weather it should be possible for home labor to raise the forms each morning, refill in the forenoon and have the remainder of the day free for other farm duties.



Monolithic Silo 14 feet 3 inches by 40 feet, holding over 200 tons; built by G. A. Ford of Oswego, N. Y., for county.



Concrete Block Silo in Minnesota, on G. W. Long's farm at Detroit. Courtesy of Holmes Stone and Lumber Co., Detroit, Minnesota.





The following estimate of labor required to construct monolithic silos is based on experience in a large number of cases, the materials being mixed by hand. The labor here given is approximate, and does not include that required to haul materials:

*Labor  
Required*

Silos 12 feet in diameter 10 to 16 days (4 hours per day) 4 men  
 Silos 16 feet in diameter 10 to 16 days (4 hours per day) 4 to 5 men  
 Silos 20 feet in diameter 10 to 20 days (4 hours per day) 5 men  
 Silos 22 feet in diameter 12 to 20 days (4 hours per day) 5 men

Steel rods are more commonly used than other kinds of reinforcing only because they come in standard sizes, the strength of which is definitely known. Any other kind of reinforcing, such as Triangle mesh, having one section rigidly attached to another, will do the work equally well, and may be successfully used if a sufficient quantity is put in to give a cross-section area equal to that of the rods recommended on chart on page 72. The quantities and weights of Triangle mesh required for varying heights and diameters of silos are given in a table appearing on pages 100 and 101 of the appendix.

*Reinforcing*

For all monolithic silos, where rod reinforcing is used instead of Triangle mesh, the vertical reinforcing should be  $\frac{1}{2}$ -inch round or twisted rods, placed in the middle of the wall at intervals of about 3 feet.

*Spacing of  
Rods*

Choosing the horizontal reinforcing is a different problem. Its size and spacing depends upon the diameter and height of the silo. The steel rings prevent internal pressure from bursting the walls. This pressure is due to the weight of the silage inside. At the top the weight of the silage is least and only a small amount of steel is needed. But farther down the weight increases and more steel must be used. At the bottom the entire weight of silage tends to burst the walls and the steel should be heaviest and closest together to take the maximum strain. All silos must be reinforced in some manner. The monolithic silo gives perfect protection to the reinforcement, from rust and fire. The graphic chart on the following page gives the sizes of rods and spacing for all common diameters and heights. The figures are liberal enough to give perfect safety.

All horizontal reinforcement must be made into continuous bands by splicing. At the splices the rods must be lapped for a distance equal to sixty-four times their diameter and tightly wrapped with wire. For  $\frac{1}{4}$ -inch rods this lapping would be 16 inches. For  $\frac{3}{8}$ -inch rods 24 inches and for  $\frac{1}{2}$ -inch rods 32 inches. Before the outer form is set up for the first ring of concrete, the horizontal reinforcing should be wired to the vertical rods, at least as high as the height of the forms. The position of the reinforcing is clearly shown in the section on page 63. The first band should be placed 2 inches above the foundation. From this point upward the spacing is indicated in the chart. For each ring of concrete the steel should be similarly placed. If a concrete cornice is built an extra reinforcing band is placed around the top to strengthen it.

*Making and  
Placing the  
Rings*

The graphic chart on the opposite page can be better understood if a specific example is given. Suppose that you wish to build a silo 14 feet

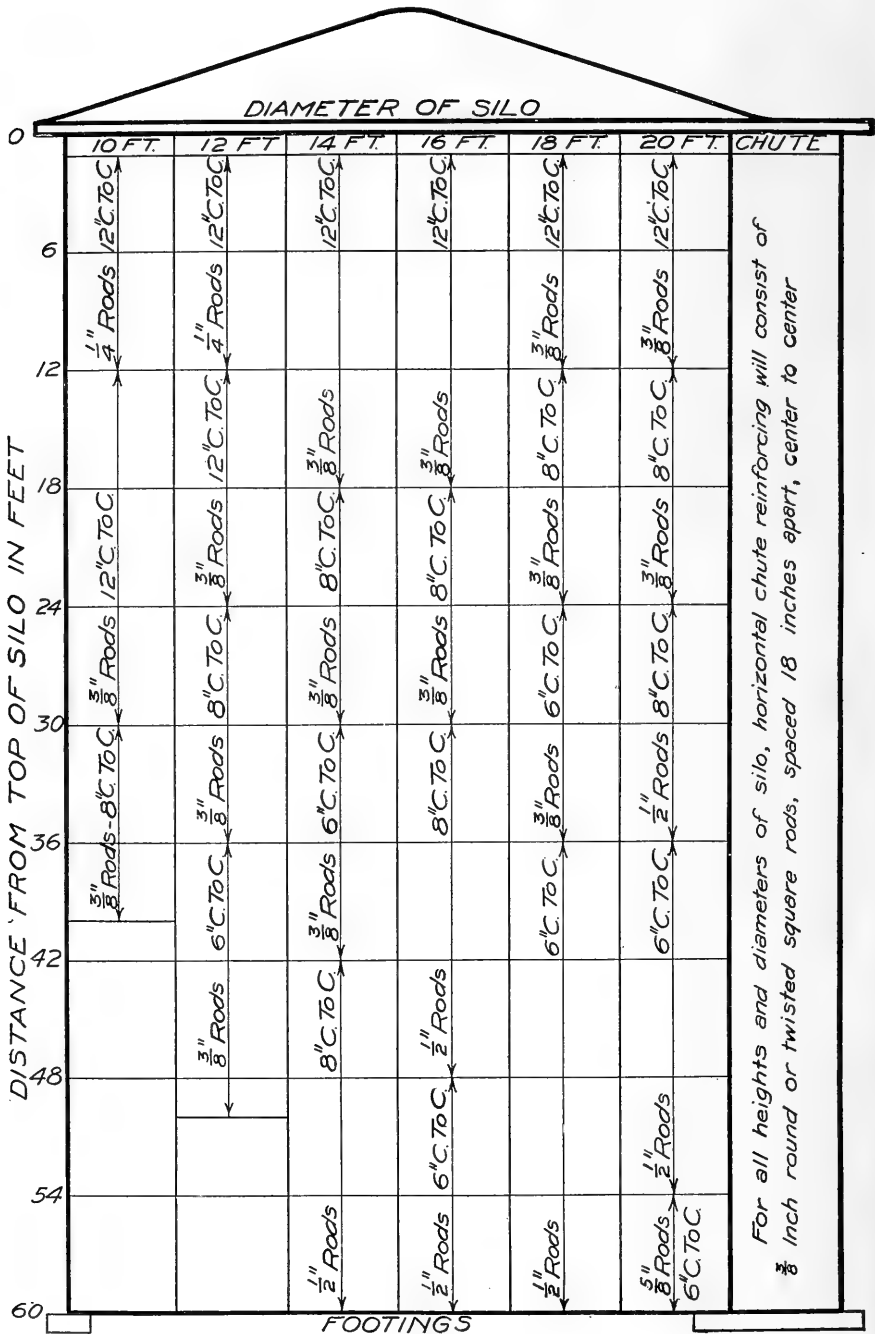

Graphic chart showing method of choosing horizontal reinforcing of round rods for a monolithic silo. The amount of reinforcing will vary with the height and diameter of the silo.

**Example**

in diameter and 42 feet high, inside dimensions. The chart has six columns, one for each diameter. Each column shows the sizes of round rods and spacing for a silo 60 feet high. For a silo 42 feet high the reinforcing will be exactly the same as for the upper 42 feet of a 60-foot silo, so that the chart may be used for all heights. At the left are figures showing the distance from roof down. Locate the 14-foot column at the top of the chart and run your finger down to the cross line marked 42 feet. That is the bottom of your silo. Now read off the sizes and spacing for the first 12 feet, from 42 up to 30 feet. It will require  $\frac{3}{8}$ -inch rods, spaced 6 inches apart. For the next 12 feet, from the 30-foot level up to 18 feet from the top,  $\frac{3}{8}$ -inch rods are still to be used but spaced 8 inches apart. You have now taken care of the first 24 feet. There are 18 feet more to build. From the 18-foot line up to the roof,  $\frac{3}{8}$ -inch rods are again to be used but spaced wider apart, 12 inches, because the weight of the silage above is less. In this case only  $\frac{3}{8}$ -inch rods are required, but other heights and diameters call for rods from  $\frac{1}{4}$ -inch to  $\frac{1}{2}$ -inch in size.

If you wish to build a silo 16 feet in diameter and 60 feet high, you will read off the sizes and spacing of rods from the 16-foot column, starting up from the bottom, at the line marked 60 feet.

The horizontal reinforcing for the chute is the same for all sizes of silos. It consists of  $\frac{3}{8}$ -inch round or twisted square rods spaced 18 inches apart.

Reinforcing rods are sold by weight in stock lengths. One-quarter-inch rods weigh 16.84 pounds per 100 feet. Three-eighths-inch round rods 37.5 pounds per 100 feet. One-half-inch round rods 66.7 pounds per 100 feet.

The work of constructing the silo will be made much easier if a convenient method of hoisting materials is adopted at the start. The old scheme of raising the concrete by hand with a rope and a bucket wastes time and materials and means much unnecessary labor.

**Hoisting Materials**

Materials may best be raised with a rope and pulley, the latter attached either to a derrick frame, as shown on page 61, or suspended from a frame resting on top of forms, the power in either case being furnished by a horse. The derrick shown in the figure may be built to any height required, in the following manner: Pieces marked "A" (2x6 inches, 16 feet long) are spliced together until a height at least 6 feet greater than that of the completed walls is obtained. Pieces "B" (1x6 inches) are nailed to "A" in such a manner as to make an I-beam as shown in the sectional view in the center. The cross arm is made of a 2x6-inch piece 3 feet long spiked to piece "A" and prevented from raising at the back end by piece "B" which runs flush with the top of the arm. The brace is made of 2x6-inch material, 3 feet 2 inches long. The three No. 9 guy wires are fastened to the cross arm and brought around in grooves provided for the purpose and fastened to stakes driven in the ground for a considerable distance from the bottom of the derrick. This device, which has been recommended by the Iowa Experiment Station, is said to have been tested and found safe for loads less than 400 pounds.

## Building Concrete Block Silos

Hollow concrete block silos are popular in all of the northern states and more especially so in sections where the winters are extremely cold. The cost of concrete block silos is often a trifle more than for those of monolithic construction, although this is not true in a great many cases. The best concrete block silos are those erected by contractors who have made a specialty of this class of work. Good block silos can be put up with home-made blocks and by home labor, but where there is a reliable block contractor in the vicinity it generally pays, in a saving of time as well as in numerous other ways, to have the work done by persons with previous experience.

When the work is done by a contractor, the owner should take the precaution of examining the blocks which go into his silo, rejecting those that are damaged or of an inferior quality. A crack of any size, or broken or crumbly edges, indicate a weakness in the block and make it unsuited for use. Blocks may be tested for their water-resisting qualities by placing a small amount of water on the surface and observing whether this remains or is absorbed. A block which readily absorbs moisture is obviously unsuited for silo work, which dampness must not penetrate. Warped and distorted blocks should be discarded because of their unsightly appearance.

The foundation already described will give as good satisfaction for the block silo as for the monolithic (see pages 54 and 55). The top of the footing must be made perfectly level, being tested frequently with a straight edge. As soon as the footing has sufficiently hardened, the top should then be cleaned off and moistened and a coat of slushy cement mortar  $\frac{1}{4}$ -inch thick put on. The first band of reinforcing should then be put in, and the first row of block laid on this mortar, beginning the blocks at the two ends of the wall next to the doorway and continuing around. The blocks may be more conveniently set in a true circle if a sweep similar to the one used in laying out the foundation is used here. Should the blocks fail to meet exactly, the circle should be enlarged or made a little smaller, whichever happens to be the more convenient. A guide board with a convex curved edge, cut on a circle of the same diameter as the inside of the silo, should then be made and used in place of, or in conjunction with, the sweep in laying up the remaining courses.

The cement mortar should consist of one sack of Portland cement to 2 cubic feet of clean sand, with the possible addition of a small quantity of hydrated lime (not over 10 per cent) to make it easier to work. Before laying up the blocks see that they are thoroughly soaked which will prevent them from drawing moisture from the mortar. No more mortar should be mixed at one time than can be used up within 30 minutes after first moistening.

Most failures reported on block silos have been due to a lack of sufficient reinforcing, caused in most cases by the overconfidence of the

**Reinforcing**

builder in the strength of the blocks, or failure to realize the enormous outward pressure of the silage. Horizontal reinforcing is of the most importance and must not be overlooked. Vertical reinforcing in block silos is not necessary. The table on page 77 shows the size of rod which should be placed between each row of block or in the groove in each row of block, if such a groove is provided. Reinforcing rods in block silos are not lapped in the ordinary fashion, but are anchored around a block or the ends are hooked together.

For illustration, assume that you are to build a concrete block silo 32 feet high, 16 feet in diameter, with blocks 8 inches in height. The right amount of horizontal reinforcing can be found by referring to the table on page 77. The height of silos, in courses of six blocks (or 4 feet), is given in the left-hand column. As the silo is to be 32 feet high, run down to the figures 28-32. This represents the bottom 4 feet of the silo. Run your finger across the page to the column headed 16, the desired diameter, and the fraction,  $\frac{1}{2}$ , indicates that a  $\frac{1}{2}$ -inch round rod is required between each two courses of blocks, between the 32-28 foot levels. Following up this column (16 feet), you will see that  $\frac{3}{8}$ -inch

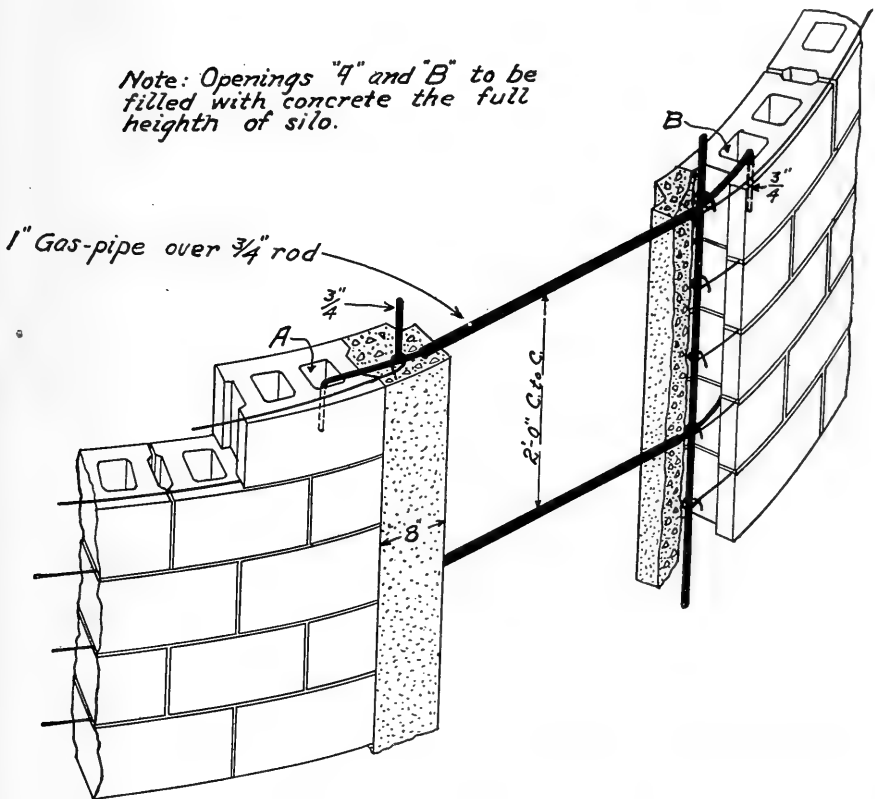

Continuous Door Opening for a Concrete Block Silo, showing the method of fastening reinforcing rods to the door frames and anchoring rods in the end blocks.





round rods are required between the 28-24-foot levels and also continuing up to and including the 12-foot level. From the 12-foot level up to the top,  $\frac{1}{4}$ -inch round rods are required between each two courses.

The reinforcing is commonly laid in the mortar between the courses of block, the strength of the mortar and the downward pressure of the blocks above being depended upon to keep the rods in place under loaded conditions. In the best practice, however, blocks are used which have a recess in the top face deep enough to accommodate the reinforcing rod. Recesses are generally put about two inches in from the outside of the block.

*Recesses for Reinforcing Rod*

*Continuous Doorways*

Concrete jambs for the continuous doorways of concrete block silos may be made as shown on page 75, and faces of the jambs should be the same as those on the continuous door jambs of monolithic silos, as described on page 63. The jambs may be easily constructed by the use of simple box molds, recesses being formed on the inside of the jambs by the use of 2x2-inch cleats. As the reinforcing rods are laid upon successive courses of blocks, they are cut off so that the ends will extend out far enough to be firmly fastened to the  $\frac{1}{2}$ -inch vertical rods to which the horizontal ladder rods are attached. These vertical rods should be located near the center of the jamb. The doors for the continuous doorway are the same as for the continuous doorways of monolithic silos, as described on page 64.

## Home-Made Blocks

A number of farmers in various parts of the country have put up concrete block silos with blocks made during spare time with a block machine, or a home-made mold. Good blocks can be made by either method, but the use of a machine quickens the work, and does it in a more uniform manner with the expenditure of a great deal less labor.

For the benefit of those who may wish to manufacture silo blocks, with a machine designed for that purpose, the following list of manufacturers, who exhibited their machines at recent Chicago Cement Shows, is given. There are also a large number of other machines on the market, capable of making good concrete silo blocks. Full information regarding these machines will be gladly given by any of the manufacturers listed below.

*Block Machine Manufacturers*

Anchor Concrete Stone Co., Rock Rapids, Iowa.  
 Ashland Steel Range & Mfg. Co., Ashland, Ohio.  
 Barron & Harridge, Insurance Exchange Bldg., Chicago.  
 Cement Machinery Co., Jackson, Mich.  
 Century Cement Machine Co., Rochester, N. Y.  
 The J. B. Foote Foundry Co., Fredericktown, Ohio.  
 Hayden Automatic Block Machine Co., Columbus, Ohio.  
 Hobbs Concrete Machinery Co., Detroit, Mich.  
 Hurst Silo Co., 819 Exchange Ave., Chicago, Ill.  
 Ideal Concrete Machinery Co., Cincinnati, Ohio.  
 Inman Concrete Block Machine Co., Beloit, Wis.  
 Lansing Co., Lansing, Michigan.  
 Miles Manufacturing Co., Jackson, Mich.



Multiplex Concrete Machinery Co., Elmore, Ohio.  
 Northwestern Distributing Co., Sioux City, Iowa.  
 Sioux City Engine and Machinery Co., Sioux City, Ia.  
 Summer Bros. Mfg. Co., Urbana, Ill.  
 U. S. Gas Machine Co., Muskegon, Mich.

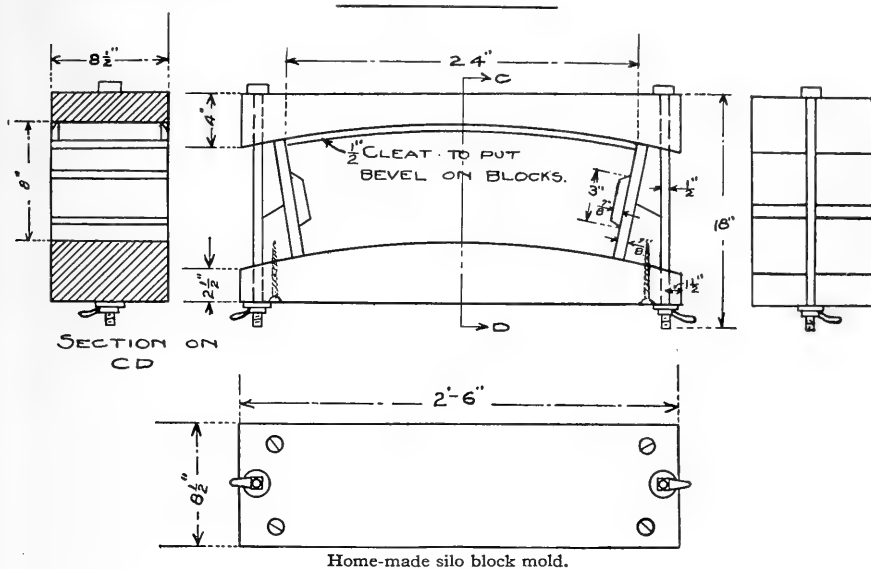

The mold shown above is a modification of that used by Wm. Stoll, of Lansing, Mich., to construct blocks for his silo. It can be used to make blocks of any length up to 24 inches and of any width up to 8 inches. The height of the blocks may be 8 inches or less.

*Home-made  
Molds*

The mold can be made from a piece of old railroad tie 30 inches long, 8 inches wide and  $6\frac{1}{2}$  inches high sawed on the arc of a circle, with a diameter 4 inches greater than that of the inside of the silo. One-half-inch holes are drilled  $1\frac{1}{2}$  inches from each end to receive 18-inch bolts, by which the sides of the mold are held at the desired distance apart. The end pieces are made of 1-inch planed lumber and have tapered wooden blocks 8 inches long, 5 inches wide and  $\frac{7}{8}$ -inch thick screwed to them for the purpose of making end cores on the blocks. The end pieces are held in place by wedge-shaped wooden blocks inserted between them and the bolts. If hollow blocks are desired, the air spaces may be provided by cores made of tapered 4x4-inch pieces. The inside of the mold should be well greased before use to prevent the concrete from sticking.

*Size of  
Block*

Although concrete blocks are made in a large variety of sizes, those most commonly used in silo work are 8 inches high, 8 inches thick and either 16 or 24 inches long, with half and quarter lengths as required. Blocks of these sizes are recommended as preferable to those less than 8 inches in height which require more labor to lay because of the greater number required, or blocks more than 8 inches in height which are unhandy because of their weight.

## Concrete Chutes

A permanent chute of concrete is a valuable adjunct to any concrete or masonry silo. The same arguments presented for the concrete silo stand for the chute. The concrete chute is substantial and permanent, fireproof and cold-proof, and it greatly improves the appearance of the silo.

Chutes in use in various parts of the country vary in size from 2 feet square to about 5 feet square (inside dimensions), but the former size is much too small and the latter larger than need be. For the average silo a chute  $2\frac{1}{2}$  feet by 3 feet in inside dimensions is recommended. The outer dimensions will then be  $3\frac{1}{2}$  feet by  $4\frac{1}{2}$  feet, the walls being 6 inches thick. A monolithic chute of this size will require one sack of cement,  $2\frac{1}{2}$  cubic feet of sand and 4 cubic feet of gravel, per foot of height. For the block silo, the size should be such as will be accommodated by whole and half blocks. The outer dimensions of a hollow block chute (using 8x8x16-inch blocks) should be 2 feet 8 inches by 5 feet 4 inches, making the inside dimensions 2 feet by 4 feet. This size will require an average of  $7\frac{1}{2}$  blocks for each course.

The foundation for the chute should be 2 feet wide and 1 foot high, the same as that for the silo, using concrete of the same proportions. (See page 83.) If a monolithic chute is to be built  $\frac{3}{8}$ -inch vertical reinforcing rods must be imbedded in the foundation 18 inches apart. Monolithic chute walls are built simultaneously with

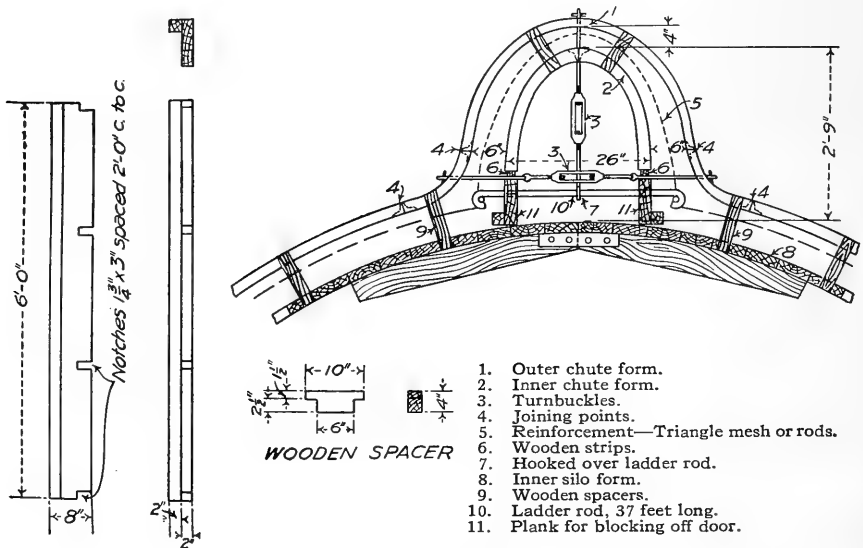

Form for Monolithic Chute.

the silo walls; chute walls of concrete block silos must also be built at the same time, being built in and kept at the same level as the silo walls.

The monolithic chute illustrated on page 80 is practically self-explanatory, as is the chute of concrete block shown on this page.

The later forms put out by the best silo form manufacturing companies now provide chute and roof forms, so that the construction is comparatively a simple matter.

If the block silo and chute are put up simultaneously the walls of the two will be held together by the blocks, and no reinforcing will be necessary. Window openings in the chute may be made by using concrete sills and lintels, which are easily obtainable from block dealers. A length of heavy strap iron may be substituted for a lintel, if desired, and the sill cast in place by means of a simple box mold.

**Block Chutes**

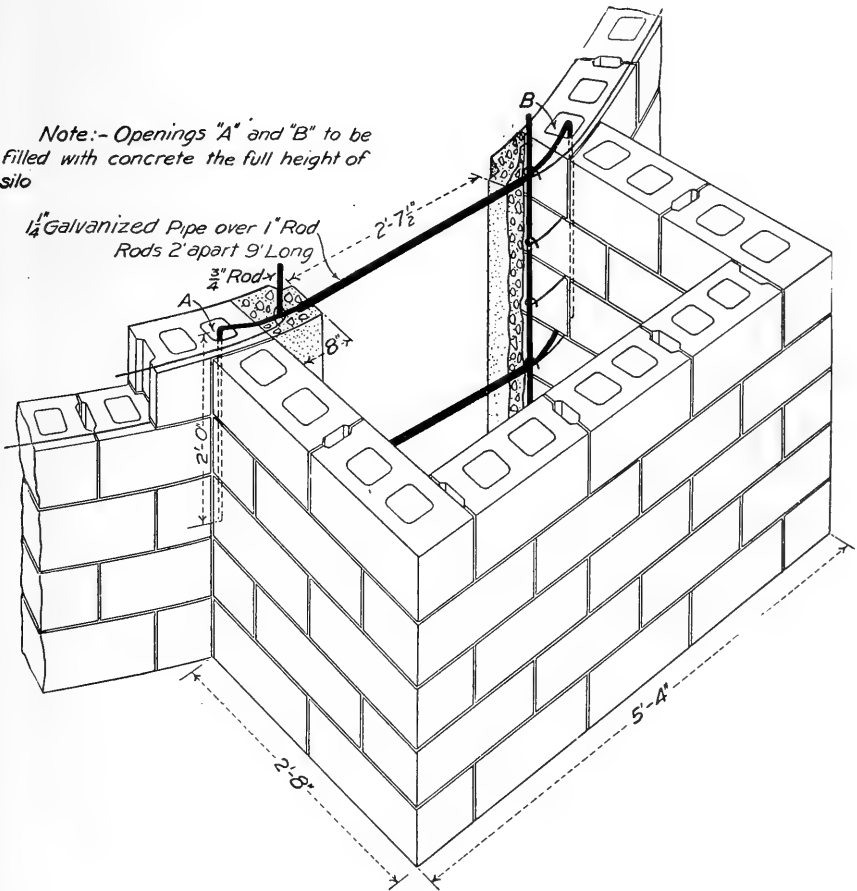

## Water Supply Tanks

The top of a monolithic silo is a convenient place for the farm water supply tank; in fact, if one were about to build a large concrete tank no better construction could be chosen than that of building the base in the shape of a monolithic silo, whether it could be put to any other use or not. Where both silo and tank are necessities, as on large stock and dairy farms, the two may well be combined.

Every farm should have a water supply tank large enough to take care of all the needs about the house and barn and still leave a reserve for use in case of fire. Fire protection can best be obtained by a supply of water under pressure. The water tank on top of the concrete silo supplies this need. The table below shows the capacities of tanks for silos with diameters of from 8 to 16 feet, assuming the tanks are filled to a height of five feet. It is hardly practical for inexperienced persons to build tanks of greater diameter than 16 feet, erected on top of silos, unless these tanks are especially designed for each particular silo. Detailed plans of larger tanks will be designed by the Universal Information Bureau, however, to fit individual cases and will be furnished upon request.

Where a tank is to be built on top of a silo, no additional reinforcing is required in the silo walls, as the weight of the tank and the water in it will have no effect on a well reinforced concrete silo. The reinforcing for the tank is shown on the chart on page 86.

In silos with continuous doorways, it is necessary to bridge across the top of the doorway before laying the tank floor. The door-frame should extend up within one foot of the bottom of the floor, and as soon as the walls have been built up to the level of the top of the frame, a reinforced concrete beam  $3\frac{1}{2}$  feet long, 12 inches high and 4 inches wide, at least 28 days old, should be put in. This beam should be reinforced with four  $\frac{1}{2}$ -inch round rods in the top and bottom, and may be made in a small mold-box. It should be placed in the inner side of the wall and the concreting then resumed up to the level of the tank floor.

### Capacity of Water Supply Tanks \*

Diameter of tank in ft.	Capacity in barrels
8	60
10	95
12	135
14	185
16	240

\*Depth of water—5 feet.

One barrel equals 31.5 gal. or 4.21 cu. ft.

As soon as the wall has been brought up to the level of the tank

*The Floor* of the tank floor, the outer form should be raised 1 foot and the inner form lowered 1 foot. A heavily-braced platform which will support the concrete floor should then be erected upon the inner form. The floor form must be made of 2-inch planks supported on 2 x 10-inch joists, braced to the staging as well as to the inner form, which must be strengthened if much of the weight of the floor is to rest upon it. The floor form must be able to support a load exceeding 125 pounds to the square foot in the case of a 16-foot silo, or 75 pounds to the square foot for an 8-foot silo. The greatest caution must be exercised in getting the framing put up in such manner that it will carry the load without danger of collapse.

The entire floor must be concreted at one operation. The necessary materials must be on hand, and provision made for mixing in large batches and elevating as speedily as possible. These are points which are absolutely essential for perfect work. The concrete should be made in the propor-

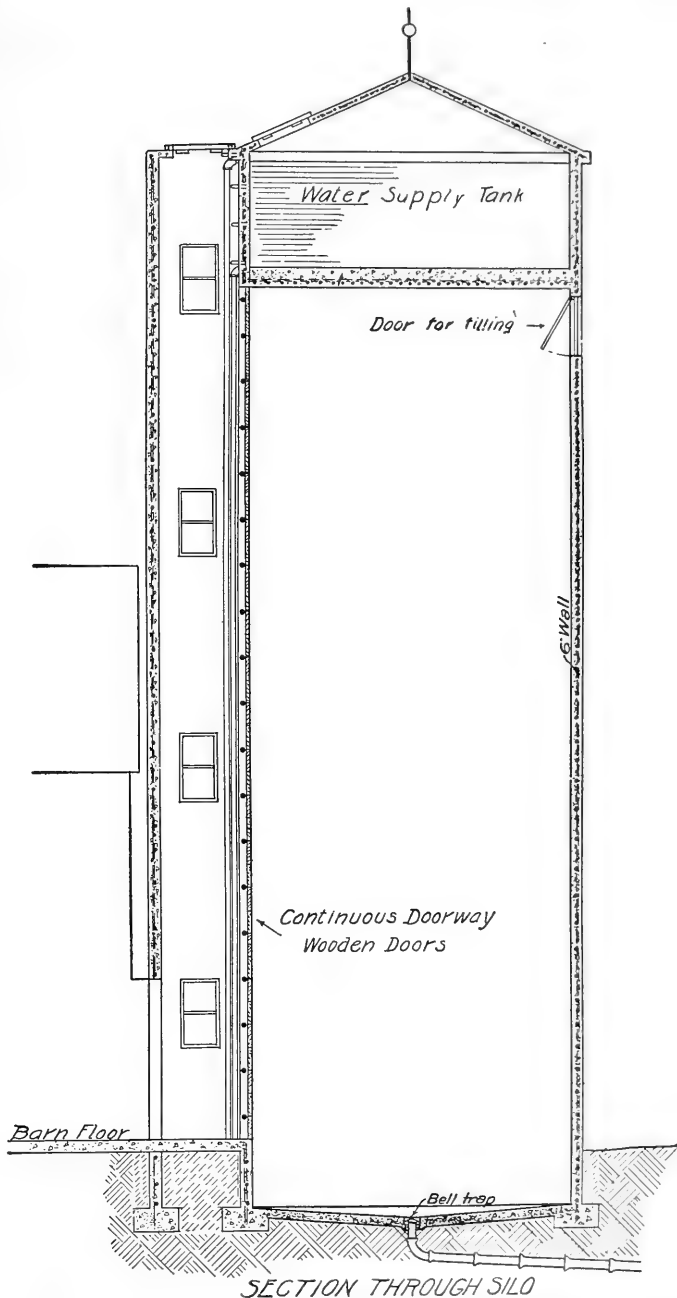

SECTION THROUGH SILO  
Sectional View of a Reinforced Monolithic Silo, showing water supply tank, roof, chute, concrete drain tile, and other essential details

tion of one sack of cement to 2 cubic feet of clean, coarse sand, and 3 cubic feet of screened gravel, the latter to contain no particles smaller than  $\frac{1}{4}$ -inch, nor larger than one inch. The concrete must be thoroughly mixed with enough water to flow with slight agitation. The following table shows the thickness of floor, amount and spacing of reinforcing and the amount of materials needed for tank floors of various sizes.

### Materials and Reinforcing for Tank Floors

Diam. of Silo and Tank in Feet	Total Thickness of Floor	Cement Required Barrels	Sand Required Cubic Yards	Gravel Required Cubic Yards	Pounds of $\frac{3}{8}$ -inch Round Reinforcing Rods Required	Pounds of $\frac{1}{2}$ -inch Round Reinforcing Rods Required	No. of Lengths	Spacing of Reinforcing Rods (Inches apart)
10	7"	2.4	.87	1.4	205	...	34-16'	4" to 8"
12	8 $\frac{1}{2}$ "	4.2	1.52	2.5	...	439	41-16'	5" to 8"
14	10"	6.7	2.42	3.9	...	535	50-16'	5" to 8"
16	10"	8.7	3.17	5.1	...	771	90-16'	4" to 8"

Before placing any of the concrete, reinforcing rods for the floor should be laid down upon the platform, as shown below. Begin to lay the rods at the center, at the closest spacing shown in the table, then lay the remaining rods running the same direction, working to the wall where the greatest spacing shown in the table may be used. The reinforcing should then be placed in the other direction in the same manner, and wired at intervals of 2 or 3 feet with ordinary hay-baling wire.

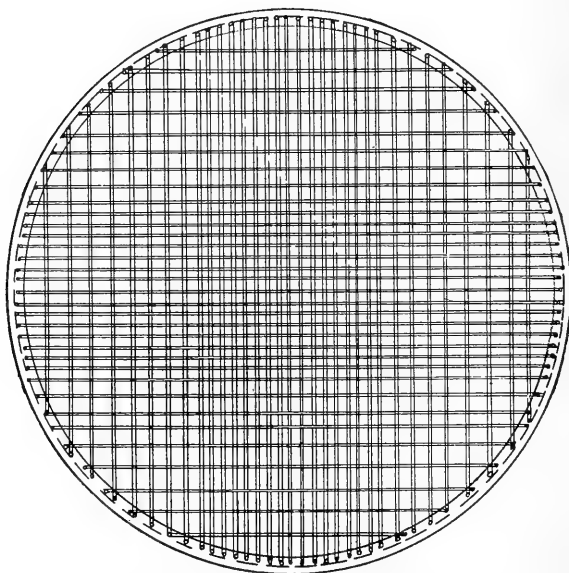

Showing the method of placing reinforcing rods in the bottom of the tank floor.

The ends of the reinforcing bars must be sufficiently long, so that each alternate rod can be turned back into the floor, 1 inch below its top surface, a distance of one-quarter the diameter of the tank and pointing towards the center, i. e., in a silo tank 16 feet in diameter, the alternate bar would be bent up from the bottom of the tank floor 8 inches, then turned back just under the top surface of the floor and running towards the center of the silo a distance of 4 feet. The remaining floor rods will be bent straight up, extending vertically a distance of 2 feet into the tank wall.

The reinforcing should be supported about an inch above the platform, on small cubes of concrete or strips of wood placed about 2 feet apart. Cement and sand mortar mixed in the proportions of 1:3 should then be put on and worked under the reinforcing to a depth of about one inch, and the concrete immediately placed upon this. In case small wooden strips are used to support reinforcing, these may be withdrawn from the underside of the floor as soon as the framing is removed, and the resulting holes filled with mortar. Concrete cubes are preferable to wooden strips, and may be easily made in the following manner: Lay down two 1-inch boards on a flat floor, one inch apart, and fill in the space between them with 1:3 mortar, trowelling off the top. The long strip of concrete thus formed may be broken up into short sections approximately cubical in shape.

After the floor has sufficiently hardened, the forms and scaffolding should be taken down, the wall forms hoisted up the outside, and placed in position on the tank floor. Before concreting is continued on the walls, the surface must be cleaned off, thoroughly moistened, and painted with cement and water grout, mixed about as thick as cream. The concrete must then be placed before the grout shows any tendency to dry. Six feet will be found a convenient depth for the tank.

#### *Continuing Walls*

The vertical reinforcing above the tank floor is put in the same as below, with  $\frac{1}{2}$ -inch rods, spaced at intervals of 3 feet around the circumference. The spacing for the horizontal rods may be obtained from the chart on page 86. By referring to the diagram, it will be seen that the vertical scale shows the distance from the top of the tank, each small division representing one inch. Across the top of the table are the tank diameters, running from 10 to 16 feet. The heavy black lines indicate the spacing of the rods. This diagram may be conveniently used for tanks six feet deep or less.

#### *Reinforcing*

Suppose it is desired to know the proper reinforcing for a tank 14 feet in diameter and 6 feet deep (to hold 5 feet of water). Running across

#### *Example*

the top horizontal column until 14 feet is reached, we find (directly below) that two sizes of rods— $\frac{3}{8}$ -inch and  $\frac{1}{4}$ -inch—are used. Running to the bottom of the vertical diagrams, it will be seen that a  $\frac{3}{8}$ -inch rod is placed 2 inches from the floor line. The next two rods are also  $\frac{3}{8}$ -inch, spaced 7 and 14 inches above the first rod. Above this point  $\frac{1}{4}$ -inch rods may be used to the top, as shown, or three more  $\frac{3}{8}$ -inch rods may be used, and the change made to  $\frac{1}{4}$ -inch rods at a point 2 feet 5 inches from the top.

The intake and outlet pipes should run up one corner of the chute, far enough from the wall so that they may be covered to prevent freezing.

*Piping and Overflow*

The overflow outlet may consist of a 3-inch pipe passing through the wall about 6 inches below the cornice. This pipe may be run down within the chute or on the outside of the silo, and led to a line of tile. In many cases, however, the pipe is simply made to stick straight out of the wall about a foot, and the overflow is not drained off in any way. This method is not recommended as a general thing, but may be suitable if close watch is kept so that the tank is rarely filled to the overflow point.

A concrete roof should cover the water tank, which will prevent the water from freezing, to a great extent. A roof also keeps the water cooler in summer and cleaner at all seasons of the year. No farmer should overlook the fire protection feature of a water tank on top of the concrete silo.

*Chart Showing Horizontal Tank Reinforcing*

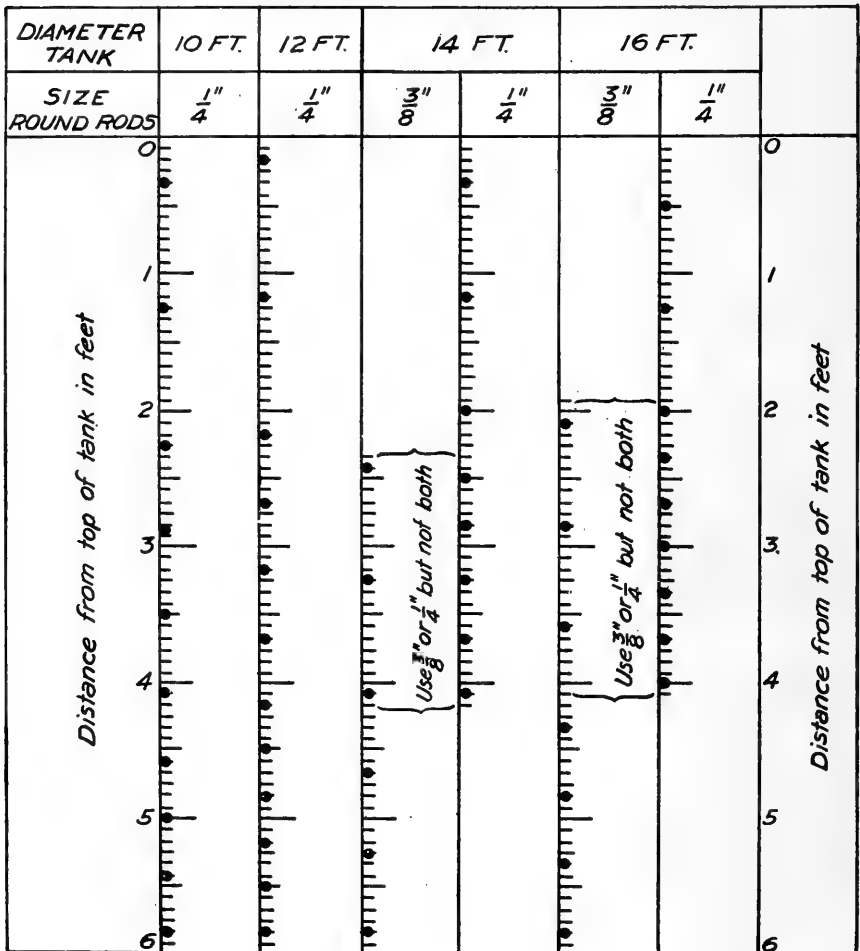



## Concrete Roofs

Some years ago, even concrete silos were built without roofs. Such is not true today, and in fact one silo contractor, W. H. Warford, of Geneva, Illinois, has invented and patented a roof form so that concrete roofs can be built on practically any type of masonry silos. The Monasco Company has made provision for roofs, and A. H. Limberg, one of the early silo form inventors, always recommended concrete roofs as well as chutes. A silo without a roof is an unfinished building. Scientific investigation has disclosed that not only the freezing of silage in winter, but its thawing-out along the north wall is prevented by the roof. The roof protects the silage by excluding the elements and maintains uniform conditions in the silo.

The functions of a roof on a silo are (1) to prevent the cold from reaching the silage, (2) to make it more convenient to work in the silo during stormy weather and (3) to prevent the silage from being spoiled by drying out by the sun.

The logical way to finish up a concrete silo is with a concrete roof. Of 110 concrete silos recently investigated by this Company, 39 had concrete roofs, 30 wooden roofs, 3 steel roofs, 13 had no roofs of any sort, and on 16 silos no note of the roof was made. Of the silos with concrete roofs, more than a majority were built during the last two years, showing that the tendency at the present time is toward the all-concrete silo—from foundation to pinnacle. If the directions given in the following paragraphs are closely followed, little difficulty will be found in putting on a good roof of concrete—one that will last indefinitely without need of

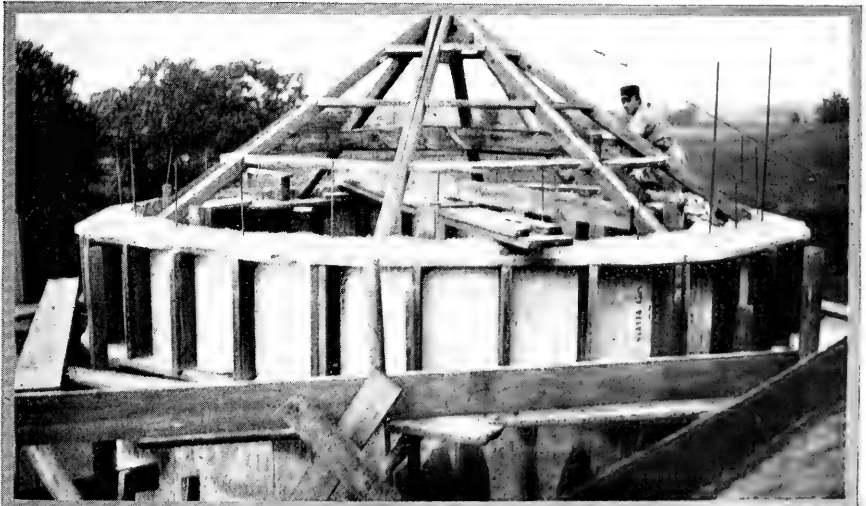

Framing for Constructing a Concrete Roof on the concrete silo; wall forms in position. The illustration is of the University of Wisconsin forms.

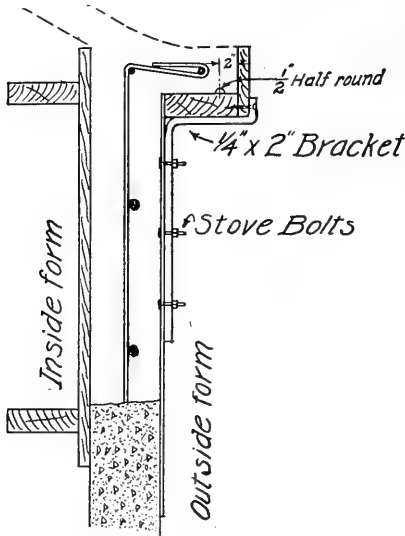

Forms in place for  
Top section and Cornice

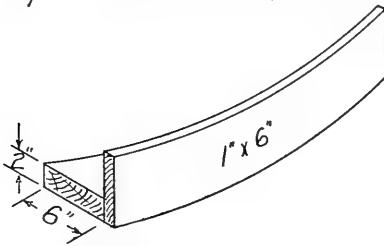

Box for Cornice

Mold Box for Silo Cornice.

be seen in the figure. The vertical rods in the silo walls and the radial rods of the roof are all brought around the horizontal reinforcing in the cornice, thus holding it in place and strengthening the cornice.

For the top section of the wall (last filling of the forms) the inner and outer forms are brought up to the line of the top of the completed wall. The forms are then filled to within one foot of the top, the outer form removed, and brackets attached. (If the stove bolts are already in place the form need not be removed to attach the brackets). The mold box will then be put in place. The cornice will be concreted at the same time as the roof, as will be explained later.

The roof framing may consist of 2x4's or similar material, as shown in the lower right-hand quadrant of the plan view, on page 90.

In case of a silo with a water tank on top, the forms must be removed before the roof framing is put up, and the latter supported on a light framework erected within the tank.

being shingled or otherwise repaired, and which will be in no danger of blowing off.

A cornice is only necessary where a roof is to be put on, its chief uses being to prevent water from the roof from running down the walls, and to improve the appearance of the silo. On this page is shown how the forms are made for the cornice on a monolithic silo.

The brackets for the forms are made of  $\frac{1}{4}$  x 2-inch strap iron bent as shown, and drilled to receive three stove bolts. These brackets should be placed on the outer form at intervals of about 6 feet, holes being drilled at the proper points to receive the stove bolts. The bottom of the cornice mold box is made of 2x6-inch planks in short lengths, sawed to the arc of a circle with diameter 1 foot larger than that of the inside of the silo. The side of the mold is made of 1x6-inch planks spiked to the bottom boards. The mold is held in place by screws through the bracket, as shown. An extra band of horizontal reinforcing is put in the cornice, as may

The roof frame may be boarded up as shown in the plan view, with boards running either radially or otherwise, as desired. These boards should be placed close together to prevent the concrete from coming through when placed upon them. The table below shows the vertical rise to be given to roofs for silos of various diameters.

A hole about  $2\frac{1}{2}$  feet square must of course be left for filling the silo, or if a roof covers a tank the hole will afford access to the latter. Before placing the reinforcing or the concrete, the top of the framing should be covered with building paper, or similar material, which will prevent the concrete from sticking to the forms. This will greatly facilitate their removal.

The upper right hand quadrant of the plan and the sectional view show the spacing of the radial and hoop reinforcing. The radial reinforcing is placed so as to be two feet apart on the circumference, and the hoop reinforcing is indicated on the design. Extra rods should be put in around the window opening if the regular rods do not follow the outline of the window closely enough to reinforce it. All intersections must be wired together, and the outer ends of the radial wires brought down and bent around the horizontal reinforcing in the cornice, as shown. The reinforcing should be supported one inch above the roof frame, so that when the concrete is put on, the rods will rest on a one-inch bed and be covered by a three-inch bed, the total thickness of the roof being four inches. For amounts of reinforcing necessary for roofs of various diameters, use the table below.

*Placing the Reinforcing*

*Table of Dimensions and Materials for Roofs for Silos with Diameters 8 Feet to 22 Feet*

Diameter of Silo	Vertical Rise	Volume of Conc. in cu. yds.	Cement Required barrels	Sand Required cu. yds.	Stone Required cu. yds.	¼ Inch Reinforcing Rods		
						No. of Rods Required	Stock Length of Rods	No. of Lbs. of Rods
10 ft.	$2\frac{1}{2}$ ft.	1.60	2.80	.80	1.20	31	12 ft.	62
12 ft.	3 ft.	2.20	3.80	1.10	1.70	33	16 ft.	88
14 ft.	$3\frac{1}{2}$ ft.	2.90	5.00	1.50	2.20	45	16 ft.	120
16 ft.	4 ft.	3.80	6.60	2.00	2.90	87	10 ft.	146
18 ft.	4 ft.	4.50	7.8	2.60	3.50	93	12 ft.	187
20 ft.	4 ft.	5.40	9.4	2.80	4.20	107	12 ft.	226
22 ft.	4 ft.	6.40	11.1	3.30	4.90	113	14 ft.	265

Concrete for roofs is made of 1 sack Portland Cement to 2 cubic feet of coarse sand to 3 cubic feet of screened gravel or crushed stone. Each cubic yard of concrete requires  $1\frac{3}{4}$  bbls. of cement,  $\frac{1}{2}$  cubic yard of sand, and  $\frac{3}{4}$  cubic yard of gravel or stone, approximately. The  $\frac{1}{4}$ -inch reinforcing rod weighs 16.7 pounds per 100 feet.

Concrete for the roof should be made in the proportion of one sack of cement to two cubic feet of coarse, clean sand, to three parts of screened

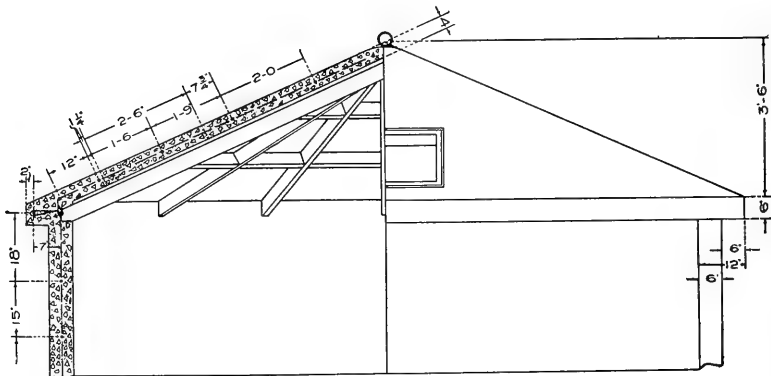
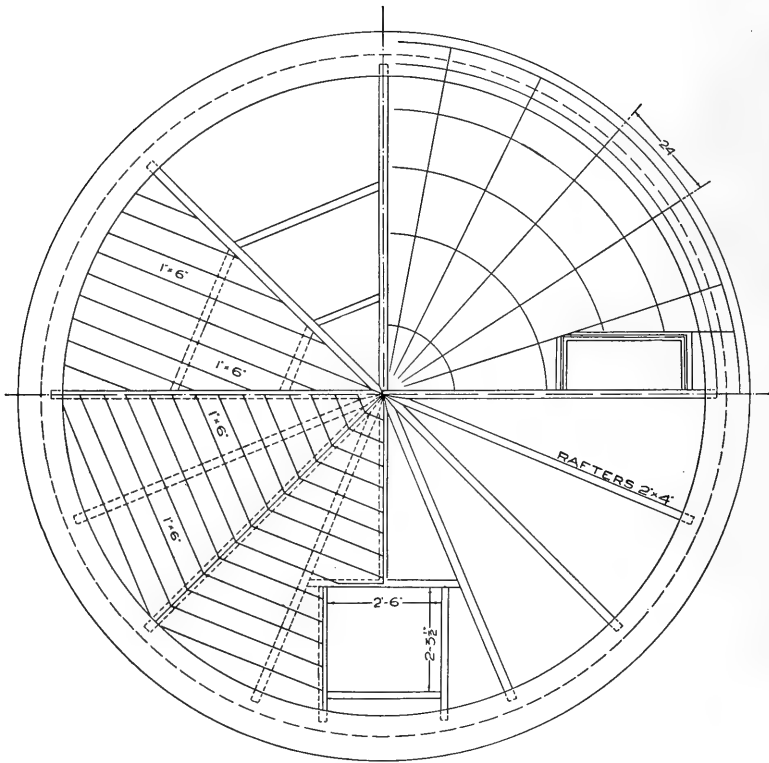

USE  $\frac{1}{4}$ " ROUND BARS  
 CONCRETE TO BE 1:2:3 MIXTURE

CONICAL CONCRETE SILO ROOF

Reinforced Concrete Roof Design. The wooden framing is removed as soon as the cover has become thoroughly hardened.

**Concreting** gravel or crushed stone. The concrete should be mixed as wet as it can be put on without danger of running to the edges of the roof due to the pitch. The top should be trowelled off smooth, in the same manner as a sidewalk. Concreting should begin at the cornice working around the roof, so as to keep the concrete on all sides at an even height. As the work progresses toward the center a broad board, on which to stand, may be laid on the concrete already laid. It will also add greatly to the safety of the men working on the roof if a rope attached to the pinnacle is tied about the waist of each. In place of this, it is often desirable, for the sake of greater safety to the workmen, to put up a scaffolding on the outside of the silo. Special care must be taken to protect the roof from sun, strong wind and freezing until thoroughly hardened. For this purpose a covering of straw, manure, or canvas is generally effective; if either straw or manure is used it may be necessary to weight it down. The effect of sun and wind is to dry the concrete out too rapidly, causing checking and cracking; while frost affects the strength of the concrete.

Where it is desired to put a monolithic concrete roof on a hollow block silo, the wall should be laid up in the usual manner until the third course of block from the top is reached. The blocks used in this course should be solid, namely, made without cores, or if with the cores these should be filled up with mortar. The last two courses of hollow block should then be laid, the cores being left open.

**Monolithic  
Roofs for  
Hollow  
Block Silos**

Special cornice blocks should be cast to make the cornice projection, and for this purpose a mold similar to that shown below can be conveniently used. The block should be 14 inches in width and of the same length on the inside of the wall as the wall blocks. The portion of the cornice blocks directly above the wall blocks should be 6 inches thick, while the projecting ends of the blocks should be but 5 inches thick, so as to give a one-inch drop. The roof framing is then put up in the same manner as described on page 88, but in this case it must be supported by the scaffolding instead of on the inner form mentioned there. The reinforcing is placed in the same manner as described on page 89 and shown in illustration on page 90, excepting that the outer ends of the radial rods are made to extend down through the holes in the block for a distance of a foot or more. Since the holes in the third course of block from the top were either omitted or filled up before these blocks were laid, holes in the two upper courses can be filled up with wet concrete as soon as the reinforcing rods are in position. The roof is concreted as described above. Before the concrete is placed on the cornice blocks this must be moistened and then painted with a cement and water grout.

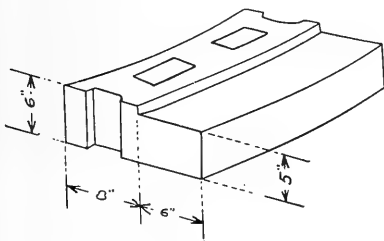

Cornice block for concrete block silo.

## Commercial Silo Systems

### Monolithic Systems

Several very ingenious systems of silo forms have been devised and put into use in various parts of the country by silo contractors and construction companies. These are of a more substantial type than the home made forms and in most cases the same form may be used to build a great number of silos. Manufacturers of these forms generally contract to build silos by their systems, but often sell the forms and territory rights or rent them to prospective builders for the job. A number of the best systems in use in this country are briefly described in the following paragraphs.

*Conklin Construction Co.* The Conklin Construction Co. of Hartford, Michigan, is manufacturing silo forms which make a poured concrete monolithic silo from footing to roof including a chute. This company claims that four men can build 6 feet of silo every day and that its machine carries its own scaffolding and is automatically lifted; also not over 200 feet of lumber is required for its operation. In addition to its use in building silos, the manufacturers claim that this machine is adapted to any circular construction such as grain bins, water tanks, etc., and that any thickness of walls may be made.

The Conklin machine is equipped with a four-inch center mast carrying adjustable arms for various diameters between 10 and 20 feet. The standard equipment shows 60 feet of center mast but additional sections can be obtained so that the silo can be built to any height desired. This company also claims that water tanks can easily be built on top of concrete silos erected with their equipment, the water tanks, of course, affording water under pressure which is not only convenient but gives good fire protection.

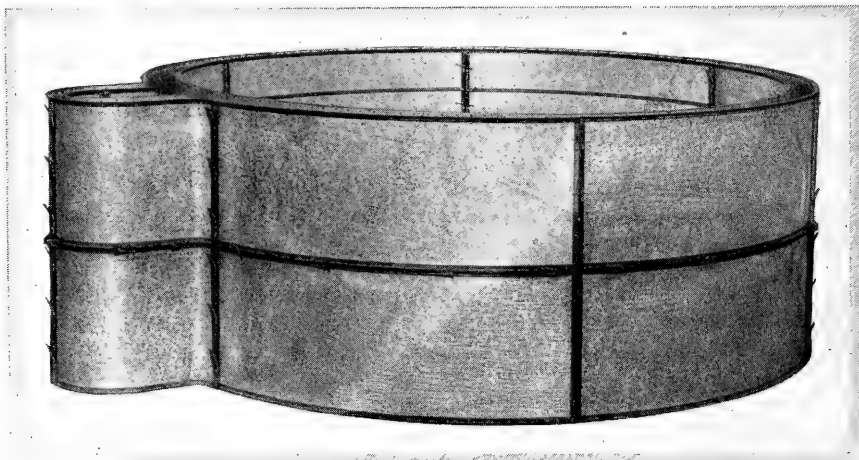

Patented Silo Molds of W. H. Limberg, Plymouth, Wisconsin. A large number of concrete silos have been built in Wisconsin and other states during the seven years these molds have been in use.

W. H. Limberg, of Plymouth, Wisconsin, has invented a silo mold for concrete silos which has been used with great success in Wisconsin and adjoining states for several years. A large number of concrete silos have been built with his forms. An advantageous feature of the Limberg concrete silo mold is the fact that it is practically 6 feet in height, consisting of two rings or circles so that six feet per day of wall can be poured. This feature decreases the time required for building. The molds are made of 18 gauge galvanized sheet steel and steel angle bars  $1\frac{1}{4} \times 1\frac{1}{4} \times \frac{3}{16}$ -inches for bracing. The form is illustrated on page 92.

*W. H.  
Limberg*

The Monolithic Silo & Construction Co., of Chicago, are the manufacturers of the Monsco molds for building reinforced concrete silos. The Monsco Company realize the necessity of having a concrete chute and roof, the chute having been one of the noted features of this company. The form for the successful building of a concrete roof is a necessary development and today practically all up-to-date silos have concrete roofs.

*Monolithic  
Silo and  
Construction  
Co.*

The Monsco molds build 6 feet per day and are illustrated on this page. They are made in two circles each three feet high and each circle is divided into four to six segments according to diameter, the chute mould making an additional segment. No. 18 gauge galvanized sheet steel, specially rolled for this purpose, is used in making them. The weight will vary from 1,900 pounds for a 12-foot mold and upward, according to diameter.

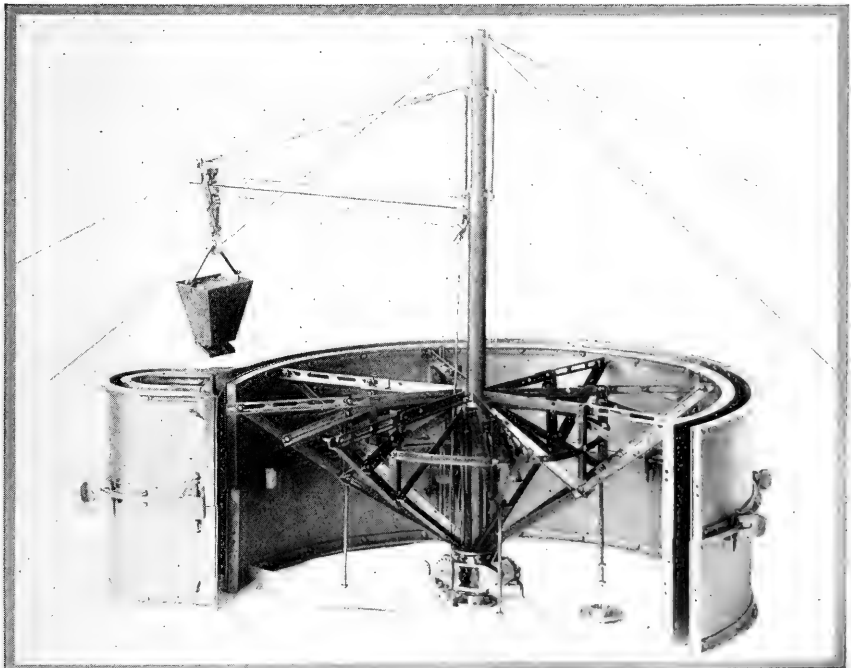

Monsco Forms. Sections removed to show details of centering and supporting device.

Holes are bored in the segments at frequent intervals to permit the insertion of the curved end of a  $\frac{3}{8}$ -inch iron rod shaped something like a stove poker, by means of which a segment is raised from one circle to the new course. A segment will weigh in the neighborhood of 125 pounds, and two men have no difficulty in handling it.

Each Monsco mold equipment includes 90 clamps for holding the segments together and 16 irons for concrete roof and cornice. A clamp is easily attached and detached and holds the segments and circles together as if in a vise.

The Monsco steel roof-molds are made of galvanized steel and are adjustable for 12-foot, 14-foot, 16-foot and 18-foot silos. The dormer window, which is one of the features of this construction, comes in two sections and can be used for any sized roof.

For a number of years John H. McCoy has been successfully using a system of forms of his own invention in the construction of large

*McCoy  
Forms*

silos and railroad water tanks in many parts of the country. This system is now owned and used by the Steel Concrete Construction Co. of Harrisville, Pa. The forms are of steel made in sections, each of which is supplied with a separate rig for hoisting. The materials are raised in steel buckets by horse power and deposited on a trough which travels around a circular track. This track makes it possible to move the trough to any part of the work that it is desired to fill.

The Peerless forms, manufactured by the New Enterprise Concrete Machinery Co. of Chicago, and used by the above company and a

*The Peerless  
Forms*

large number of silo contractors, are built of heavy galvanized sheet iron with angle iron stiffeners. Both inner and outer forms are built in sections which are coupled together with small steel pins or spikes. They are held at the proper distance apart by a steel frame which also supports a derrick. The materials are raised in a steel bucket, horse power being used.

The Polk system is operated by the Polk-Genung-Polk Co. of Fort Branch, Indiana, and a number of licensed contractors. The inner and

*The Polk  
System*

outer forms are of heavy galvanized sheet iron, stiffened with angle iron. They are suspended by rods and chains from an iron collar which slides on a hollow steel mast. The inner and outer forms are kept perpendicular and also held at proper distances apart by radial horizontal angle irons. These also serve to hold a platform.

One of the chief advantages of the Polk System is the method of elevating the concrete and depositing it within the forms. The apparatus consists of a steel bucket and cable, the latter running over a pulley attached to a trolley which travels on a steel boom. This boom is attached to the central mast by means of a collar which allows it to swing around in a full circle. After it is filled with concrete the bucket travels upwards until it reaches the trolley on the boom. The trolley is then released automatically and the bucket travels until directly over the forms. The trolley is prevented from going further by a stop consisting of a steel pin placed through a hole in the boom. Power for elevating the materials is generally supplied by a horse. The forms are raised in the following manner:



A small flat collar is pinned in position to the mast about two feet below the collar which supports the forms. Two long jacks are then placed on the flat top of the lower collar in such a manner as to raise the upper collars when the jacks are operated. The mast is provided with holes a short distance apart to receive steel pins, and as soon as the jacks have been raised to their limit a pin is placed through the mast just below the upper cylindrical collar to prevent the form dropping while the jacks are being moved up to a new position. The forms must be loosened, of course, before any attempt is made to raise them with the jacks.

The silos constructed by the Polk System have single walls six inches thick, reinforced with twisted steel rods  $\frac{1}{4}$ -inch to  $\frac{5}{8}$ -inch in size. They are built with elliptical door openings, one door to every five feet in height. Except where especially desired by the owner, roofs and chutes are not supplied. The Polk System is protected by United States patents.

Reichert Flexible or Adjustable Silo Molds are manufactured by the Reichert Manufacturing Co. of Milwaukee, Wisconsin. The Reichert Manufacturing Co. is an old and well established company and the metal molds for monolithic concrete work, of which they are the manufacturers and patentees, have proved their merit for considerable time.

*Reichert  
Manufacturing  
Co.*

The silo building outfit as furnished by the Reichert Co. consists of sectional molds, each two (2) feet in height and two (2) feet in width. Smaller plates called fillers can be inserted between the larger molds to make up the required diameters. There are also rectangular plates which are fastened to the circular molds at any point, and construct the chute portion. For every different diameter silo there are two sets of sectional rings, which fit snugly to the inside molds, holding the plates to a true circle. These rings also act as a support for the sectional adjustable scaffold arms radiating from the center. Every outfit has two sets containing eight each of the these radial adjustable arms, making sixteen arms in all.

In the center of the silo a halved collar bolted together acts as the other end support for the scaffold arms. Each half is attached to one scaffold arm, so that when the scaffold is raised, all that is necessary is to loosen the bolts holding the two halves of the collar together. This collar has a flat shoulder projecting about 3 inches from the center. On the outside edge there are slots to receive the other six scaffold arms. The center mast is made up of four (4) sections of pipe, each being 10 feet in length. This pipe is  $2\frac{3}{4}$  inches inside diameter, and is fastened together by means of couplings. At intervals of 22 inches along the pipe there are  $\frac{3}{8}$ -inch holes, into which small rods are inserted, to act as a ladder as well as a support for the collar which in turn holds the scaffold rigid.

The Silo Equipment Co. of Minneapolis has just put on the market a new monolithic silo form. The sides of the form are made of 14-gauge galvanized iron, braced on the inside with steel bars radiating from the center mast. The hoist for lifting the concrete is also connected to the center mast. This form differs from other steel forms in that it is supported on the vertical reinforcing rods and not on the concrete structure.

*Silo  
Equipment  
Co.*

The St. Jacob Lumber & Hardware Co., of St. Jacob, Illinois, are manufacturers of silos, building block pillars and other poured or cast concrete work. In the last two years a number of successful silos have been built near St. Jacob and other parts of Illinois, by this company, using the Blummer Perfect Silo Form, owned by them.

The Puffer-Hubbard Manufacturing Co., of Minneapolis, Minn., has recently put out what are called Duplex Forms, for building concrete silos. This company claims that the special advantage of these forms is their use in placing monolithic concrete foundations, such as are required for all types of silos, whether concrete or other material. This company does not manufacture hoisting machinery, nor do they furnish complete silo equipment, but these forms can undoubtedly be handled successfully by following the directions as to bracing, etc., given on page 56.

The diameters of silos which can be built with these forms are of different sizes, varying from ten to twenty feet. The inner form consists of eight segments held together by two 2-inch by 6-inch by 2-foot cleats, cut to the same circle. These hold the segments to a true circle. Three-foot lengths of 1-inch boards are nailed to the curved edge of the ribs, the latter being placed 2 feet center to center. These boards are then covered with 28-gauge galvanized sheet steel.

Eighteen-gauge galvanized sheet steel is used for the outer forms fitted with proper attachments for clamping the sections together, and raising them to their new position, as the work progresses.

W. H. Warford of Geneva, Illinois, a successful concrete silo contractor, has perfected and patented a roof form. Mr. Warford uses the Polk System of reinforced concrete construction for the building of silos, but the roof form is of his own manufacture. A detail of these roof forms is shown on this page. These roof forms have been in successful operation and the inventor claims that concrete roofs can be put on silos with this form very easily and at a comparatively low cost, all factors considered. The form weighs about 1200 pounds complete. It is light in weight, self-centering, has twenty-four reinforced ribs and allows for a 6-inch ventilator on top. All sections are identical except the one with the manhole. The form is also suggested for use in building roofs of combination milk rooms, water towers, small grain bins, grain storage and cattle tanks.

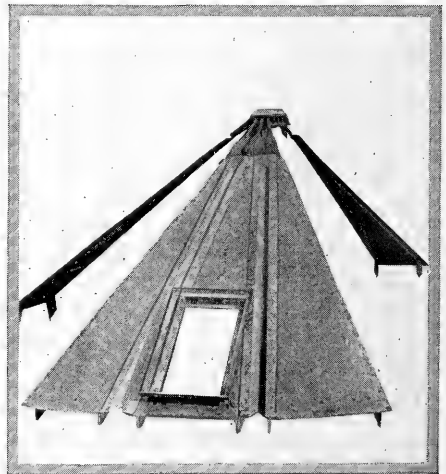

Detail of Roof Forms (patented) of W. H. Warford, Geneva, Illinois, a successful silo contractor who has built a number of good concrete roofs on concrete silos with this form.

## Concrete Block Systems

The Elgin silo, built by The Elgin Silo Co., Elgin, Illinois, is a concrete slab type, as illustrated at the right on this page. This company manufactures and delivers the slabs to the contractor or farmer. The slab method of construction appears to be an improvement over some unit methods and the protection of the steel reinforcing bands by concrete is undoubtedly an improvement.

*Elgin Silo Co.*

The Hurst Silo Co., at 416 McCormick Building, Chicago, manufactures concrete blocks for reinforced concrete silo or tank construction.

*Hurst Silo Co.*

The Hurst silo blocks have been successfully used in a large number of silos, and the Hurst silo block molds are manufactured and sold by them. These molds are furnished in sets of ten each. There are no screws or bolts used in the Hurst molds, which are 23½ inches long, 11¾ inches high, and 4 inches thick, containing approximately 2/3 of a cubic foot. At the left of pages 97 and 98 are shown Hurst silos.

One of the features in the Hurst silo block is the method of reinforcing, which is simple and effective. It is sometimes lost sight of in building block silos that reinforcement is just as necessary in this type as in any other type. The Hurst Co. provides a roof frame on which a reinforced concrete roof can be constructed.

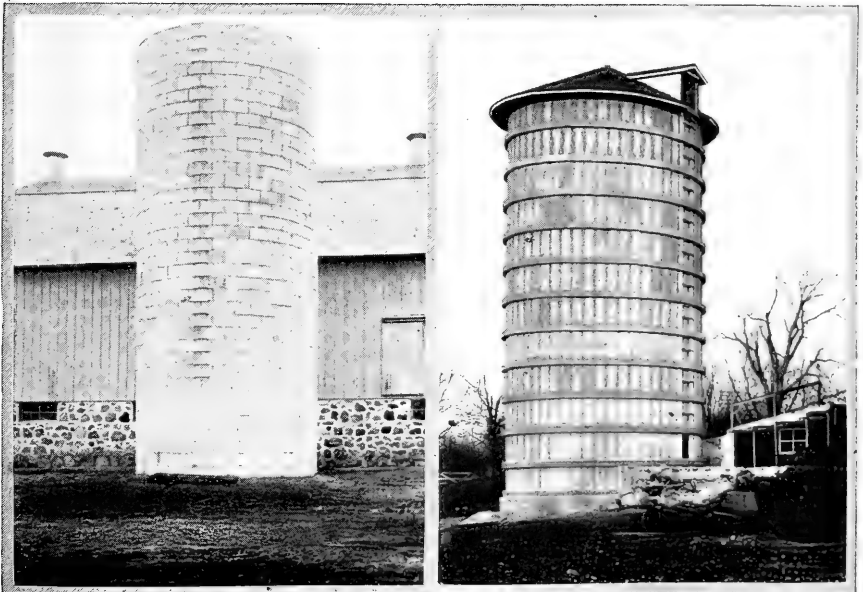

Hurst Reinforced Concrete Block Silo, built on J. W. Cooper's farm at Whitewater, Wisconsin, by Chas. B. Hurst Co., Chicago.

Cement Slab Silo on D. B. Hoornbeck's farm, Elgin, Illinois; built by Elgin Cement Silo Co. Fire destroyed other buildings.

The Perfect Silo, built by the Perfect Reinforced Silo & Cistern Block Co., of Delaware, Ohio, has met with great favor amongst Ohio farmers and a large number have been put up in Delaware and adjacent counties. Some of these silos have been built by the owners with block purchased from the above company.

*The Perfect Silo*

This system differs from all others in the dimensions of the blocks and the method of reinforcing. The blocks are 24 inches long, 12 inches high, and 4 inches thick. Each block is reinforced with two iron bands running lengthwise 6 inches apart. Each rod is looped and turned 6 inches from each end. These loops are spaced so as to correspond with  $\frac{1}{2}$ -inch round vertical holes which are formed in the block. When the blocks are laid in the wall these vertical openings are filled with cement grout and steel dowel pins are passed through this soft material and inserted about half way in the block below. The rods should be of such length that they will reach up about half way in the blocks above. The blocks have a groove  $\frac{1}{2}$  inch deep in the top edge which provides space for a larger mortar bed and also for the heavy horizontal rods which span the continuous door openings at intervals of 2 feet. These rods are firmly fastened to the vertical dowel pins. The dowels next to the door openings are made of heavy pipe in 4-foot sections firmly screwed together.

This system is shown on page 99.

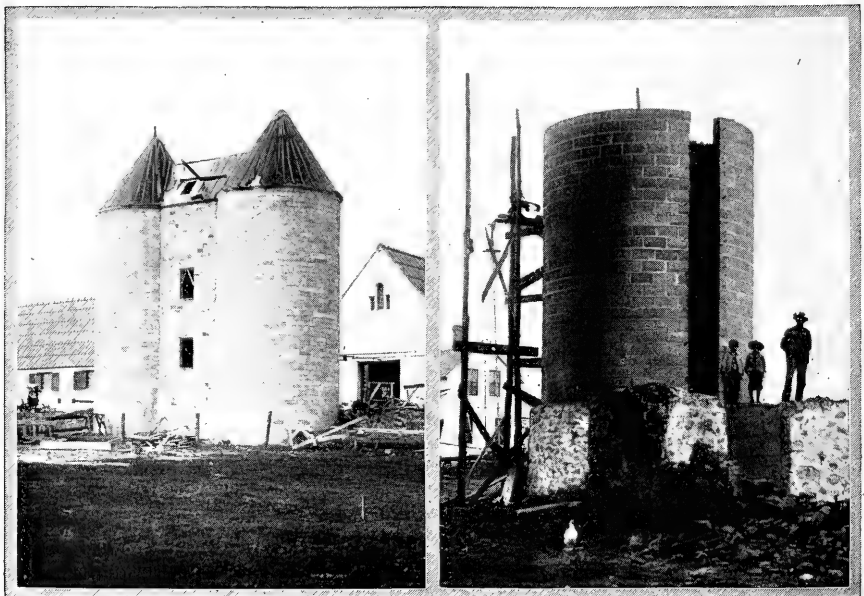

Hurst Silos built on famous Crab Tree Farm, Lake Bluff, Illinois. Built after fire had destroyed everything but concrete milk house.

Concrete Block Silo of John Hubing, at Loyal, Wisconsin. Fire completely destroyed barn; silo and contents uninjured.

A very interesting type of concrete block silo is being used extensively through the region between Holland and Grand Rapids, Michigan, which is known as the Zeeland silo and has been built exclusively by *The Zeeland Silo* Chris DeJonge, of Zeeland, Mich.

About 50 Zeeland silos have been put up by him in Ottawa County alone. The Zeeland silo has a number of unique features. It is the only silo of its kind using solid blocks made "tongue and groove" so as to fit any diameter of silo. The blocks are made 24 inches long and 8 inches high and have a thickness of only 3 inches. They are laid up in 1:2 cement and sand mortar and the inside of the wall is plastered off with mortar of the same proportion. Reinforcing consists of a heavy iron rod around each course, laid in a groove provided in the top of the blocks.

Mr. DeJonge has secured patents on a semi-circular steel chute and ladder which is placed on the inside of the silo. This permits the silo walls to be built up full all around, the only opening necessary being a door in the bottom. The chute is held to the silo wall by means of hooks and eyelets, the latter being placed in the wall at the time of building. When it is desired to feed off the silage, two top sections of the chute are removed, and as the height of the silage is lowered successive sections are removed and hung two spaces higher.

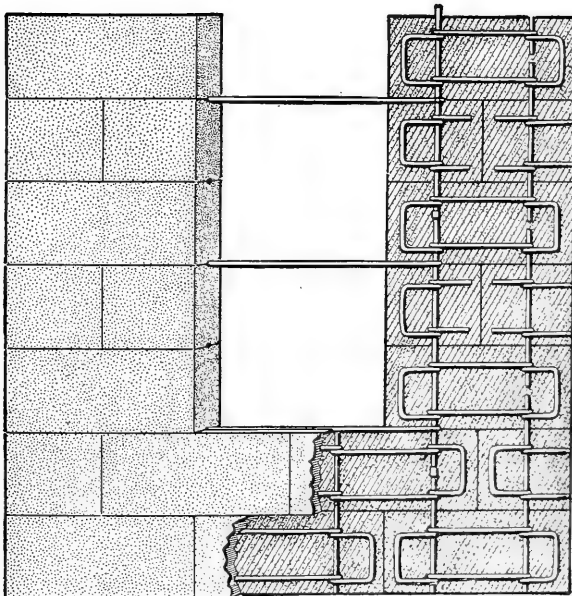

Sectional view showing construction of the Perfect Silo and method of reinforcing continuous doorway.

*Table Giving Lineal Feet of Triangle Mesh Reinforcement*

Height of Silo	Inside Diameter of Silo			
	10 Feet	12 Feet	14 Feet	16 Feet
24 Feet	333 Style No. 6 34 Style No. 4	347 Style No. 6 40 Style No. 4	347 Style No. 6 89 Style No. 4	336 Style No. 6 151 Style No. 4
27 Feet	343 Style No. 6 34 Style No. 4	357 Style No. 6 77 Style No. 4	357 Style No. 6 132 Style No. 4	346 Style No. 6 204 Style No. 4
30 Feet	353 Style No. 6 64 Style No. 4	367 Style No. 6 114 Style No. 4	367 Style No. 6 178 Style No. 4	405 Style No. 6 253 Style No. 4
33 Feet	363 Style No. 6 95 Style No. 4	377 Style No. 6 150 Style No. 4	420 Style No. 6 221 Style No. 4	468 Style No. 6 302 Style No. 4
36 Feet	373 Style No. 6 125 Style No. 4	387 Style No. 6 190 Style No. 4	476 Style No. 6 264 Style No. 4	527 Style No. 6 355 Style No. 4
39 Feet	383 Style No. 6 159 Style No. 4	433 Style No. 6 227 Style No. 4	529 Style No. 6 310 Style No. 4	586 Style No. 6 404 Style No. 4
42 Feet	393 Style No. 6 189 Style No. 4	483 Style No. 6 264 Style No. 4	582 Style No. 6 353 Style No. 4	596 Style No. 6 506 Style No. 4
45 Feet	434 Style No. 6 220 Style No. 4	530 Style No. 6 300 Style No. 4	638 Style No. 6 396 Style No. 4	606 Style No. 6 604 Style No. 4
48 Feet	477 Style No. 6 250 Style No. 4	570 Style No. 6 340 Style No. 4	648 Style No. 6 485 Style No. 4	619 Style No. 6 706 Style No. 4
51 Feet	518 Style No. 6 281 Style No. 4	626 Style No. 6 377 Style No. 4	658 Style No. 6 571 Style No. 4	629 Style No. 6 808 Style No. 4
54 Feet	558 Style No. 6 314 Style No. 4	636 Style No. 6 450 Style No. 4	668 Style No. 6 660 Style No. 4	639 Style No. 6 906 Style No. 4
57 Feet	599 Style No. 6 345 Style No. 4	646 Style No. 6 527 Style No. 4	678 Style No. 6 746 Style No. 4	649 Style No. 6 959 Style No. 4 53 Style No. 23
60 Feet	642 Style No. 6 375 Style No. 4	656 Style No. 6 600 Style No. 4	688 Style No. 6 835 Style No. 4	659 Style No. 6 1008 Style No. 4 102 Style No. 23
Floor	38 Style No. 6	48 Style No. 6	68 Style No. 6	87 Style No. 6
Roof	96 Style No. 6	134 Style No. 6	182 Style No. 6	240 Style No. 6

NOTE:—Use 38" widths of mesh and lap 2" or use 42" widths and lap 6".  
Reinforcement furnished only in rolls 150', 200' and 300' long.

*Table Giving Linear Feet of Triangle Mesh Reinforcement*

Height of Silo	Inside Diameter of Silo		
	18 Feet	20 Feet	22 Feet
24 Feet	368 Style No. 6 173 Style No. 4	337 Style No. 6 254 Style No. 4	362 Style No. 6 279 Style No. 4
27 Feet	433 Style No. 6 229 Style No. 4	409 Style No. 6 319 Style No. 4	372 Style No. 6 419 Style No. 4
30 Feet	502 Style No. 6 285 Style No. 4	484 Style No. 6 381 Style No. 4	382 Style No. 6 558 Style No. 4
33 Feet	568 Style No. 6 343 Style No. 4	556 Style No. 6 443 Style No. 4	392 Style No. 6 698 Style No. 4
36 Feet	636 Style No. 6 399 Style No. 4	566 Style No. 6 570 Style No. 4	402 Style No. 6 837 Style No. 4
39 Feet	646 Style No. 6 513 Style No. 4	576 Style No. 6 697 Style No. 4	412 Style No. 6 977 Style No. 4
42 Feet	656 Style No. 6 628 Style No. 4	586 Style No. 6 824 Style No. 4	422 Style No. 6 1116 Style No. 4
45 Feet	666 Style No. 6 739 Style No. 4	596 Style No. 6 951 Style No. 4	432 Style No. 6 1116 Style No. 4 140 Style No. 23
48 Feet	676 Style No. 6 798 Style No. 4 59 Style No. 23	606 Style No. 6 951 Style No. 4 127 Style No. 23	442 Style No. 6 1116 Style No. 4 279 Style No. 23
51 Feet	686 Style No. 6 853 Style No. 4 115 Style No. 23	619 Style No. 6 951 Style No. 4 254 Style No. 23	452 Style No. 6 1116 Style No. 4 419 Style No. 23
54 Feet	696 Style No. 6 909 Style No. 4 173 Style No. 23	629 Style No. 6 951 Style No. 4 381 Style No. 23	465 Style No. 6 1116 Style No. 4 558 Style No. 23
57 Feet	706 Style No. 6 968 Style No. 4 229 Style No. 23	639 Style No. 6 951 Style No. 4 508 Style No. 23	475 Style No. 6 1116 Style No. 4 698 Style No. 23
60 Feet	716 Style No. 6 1023 Style No. 4 285 Style No. 23	649 Style No. 6 951 Style No. 4 635 Style No. 23	485 Style No. 6 1116 Style No. 4 837 Style No. 23
Floor	102 Style No. 6	125 Style No. 6	154 Style No. 6
Roof	300 Style No. 4	328 Style No. 4	400 Style No. 4

NOTE:—Use 38" widths of mesh and lap 2" or use 42" widths and lap 6".  
Reinforcement furnished only in rolls 150', 200' and 300' long.

Table—Cost of Filling 59 Concrete Silos

State	SILAGE CUT				LABOR						COST										
	Total Silage Cut TONS	Time to Cut DAYS	Am't Cut Per Day TONS	CUTTING CROP		HAULING		OTHER LABOR		of Cutting Crop	of Hauling to Cutter	Other Labor	Fuel	Engine Rental	Total Cost	Cost Per Ton					
				MEN	TEAMS	DAYS	Men and Teams	Days	Men in Silo								Men in Field	Men at Cutter			
																			Men	Days	
Ill.	208	5	41.6	1	1	5	5	5	1	1	5	1	1	1	\$25.00	\$60.00	\$	\$100.00	\$185.00	\$0.89	
"	105	6	39.3	1	1	6	4	4	1	1	6	1	1	1	30.00	96.00	9.00	61.00	196.00	.83	
"	282	3½	80.5	1	1	3½	5	3½	2	2	3½	2	2	2	15.75	78.75	28.00	7.88	130.38	.46	
"	282	3½	80.5	1	1	3½	5	3½	2	2	3½	2	2	2	15.75	78.75	28.00	7.88	130.38	.46	
"	58	¾	77.5	6	6	¾	7	¾	2	3	¾	2	3	1	9.00	21.00	4.50	10.50	45.00	.78	
"	230	4	115.0	1	1	4	5	4	2	10	4	2	2	2	18.00	90.00	112.50	32.00	252.00	.55	
"	282	4	141.0	1	1	5	5	5	2	10	5	2	2	2	27.00	112.50	140.00	40.00	319.50	.57	
"	167	3	55.6	1	1	3	3	3	1	1	3	1	1	1	12.00	36.00	6.00	15.00	69.00	.41	
"	180	2	90.0	2	2	2	7	2	1	1	2	1	1	1	12.00	42.00	12.00	30.00	96.00	.53	
"	200	3	66.6	1	2	3	5	3	1	1	3	1	1	1	18.00	45.00	12.00	27.00	102.00	.51	
"	181	3	60.3	1	1	3	7	3	2	2	3	2	2	2	12.00	84.00	12.00	5.00	114.33	.63	
"	120	2½	48.0	1	1	2½	3	2½	2	2	2½	2	2	1	10.00	30.00	18.00	26.00	84.00	.70	
"	282	3	94.0	1	1	3	5	3	2	1	3	2	1	1	12.00	60.00	18.00	10.00	100.00	.86	
Mich.	285	5	57.0	.....	.....	.....	.....	.....	.....	.....	.....	.....	.....	.....	.....	.....	.....	.....	.....	.....	.....
"	285	5	57.0	.....	.....	.....	.....	.....	.....	.....	.....	.....	.....	.....	.....	.....	.....	.....	.....	.....	.....
"	164	2	82.0	2	2	2	6	2	2	2	2	2	2	2	14.00	42.00	24.00	28.00	108.00	.66	
"	170	3	56.6	1	1	3	4	3	2	2	3	2	1	1	12.00	48.00	26.25	40.00	126.25	.74	
"	95	2½	38.0	5	.....	2½	3	2	1	1	2½	3	1	1	18.75	27.00	4.50	22.50	72.75	.77	
"	118	2	59.0	6	.....	2	5	2	1	1	2	1	1	1	18.00	30.00	6.00	28.50	82.50	.70	
"	55	2	27.5	2	2	2	5	1	1	1	2	1	1	1	14.00	17.50	6.00	12.00	49.50	.90	
"	51	2	25.5	1	1	2	3	1½	2	2	2	2	2	2	12.25	13.50	10.50	8.00	44.25	.87	



"	67	2	33.5	1	1	1 1/2	4	1	2	1	1	6.00	16.00	7.00	7.50	45.00	.67
"	70	1 1/2	46.6	1	1	2	5	1	2	2	1	8.00	20.00	10.00	7.50	36.50	.52
"	94	2	47.0	1	1	1	3	1	2	3	1	4.00	12.00	16.00	26.00	64.00	.68
"	92	1	92.0	1	1	1	3	1	2	3	1	4.00	12.00	16.00	26.00	39.00	.43
"	100	2 1/2	40.0	1	1	2 1/2	3	1	2	5	2	10.00	12.00	18.00	11.00	51.00	.51
"	138	2	69.0	1	1	1 1/4	6	1 1/2	2	3	2	35.00	30.63	5.00	5.00	70.63	.51
"	138	3	46.0	1	1	3	5	1 1/4	2	1	1	10.50	21.98	10.00	24.00	66.38	.48
"	87	1	87.0	2	2	1	4	1	2	1	1	7.00	14.00	8.00	22.50	51.50	.59
"	175	3	58.3	1	1	3	5	2	2	2	1	10.50	35.00	17.50	10.00	78.00	.45
Wis.	46	1	46.0	3	3	1	3	1 1/2	2	2	1	5.25	5.25	12.50	7.00	30.00	.65
"	70	1	70.0	1	2	1	5	1	1	1	1	5.00	15.00	4.00	10.00	34.00	.49
"	30	1	30.0	4	4	1	3	3/4	2	2	1	8.00	6.75	10.00	5.00	29.75	.99
"	43	1	43.0	4	4	1	4	3/4	2	1	1	8.00	9.00	8.00	8.00	33.00	.77
"	45	1 1/2	90.0	7	7	1 1/2	3	1	2	2	1	7.00	9.00	6.66	8.40	31.06	.69
"	180	2 1/2	72.0	2	2	2 1/2	5	2 1/2	1	1	1	15.00	37.50	15.00	12.00	79.50	.44
"	90	2	90.0	2	2	2	5	2 1/2	1	1	1	15.00	37.50	15.00	12.00	79.50	.50
"	120	2 1/2	48.0	1	1	2 1/2	4	1 1/2	2	3	2	10.00	24.00	21.00	2.50	57.50	.48
"	120	2 1/2	48.0	1	1	2 1/2	4	1 1/2	2	3	2	10.00	24.00	21.00	2.50	57.50	.48
"	161	5 1/2	39.3	1	1	5 1/2	2	6 1/2	2	2	2	16.50	39.00	72.00	7.00	134.50	.84
"	79	2	39.5	1	1	2	2	2	2	2	2	16.50	39.00	72.00	7.00	134.50	.86
"	120	2 1/2	48.0	1	1	2 1/2	4	2 1/2	1	1	1	8.75	30.00	15.00	8.00	61.75	.52
"	120	2	60.0	1	1	2	4	2	1	1	1	8.00	32.00	14.00	6.00	60.00	.50
"	120	2	60.0	1	1	2	3	2	1	1	1	7.00	21.00	12.00	6.00	46.00	.39
"	167	3	56.6	1	1	3	5	2 1/2	1	1	1	9.00	37.50	11.25	5.00	57.75	.35
"	194	3	64.6	2	2	3	4	3	1	1	1	24.00	48.00	18.00	28.00	118.00	.61
Minn.	205	2 1/2	82.0	2	2	2 1/2	6	2 1/2	2	1	1	20.00	60.00	20.00	16.00	116.00	.57
"	83	1 1/2	53.3	1	1	1 1/2	3	2	2	1	1	5.25	18.00	16.00	10.00	49.25	.59
"	100	2	50.0	2	2	2	4	1	2	1	1	16.00	16.00	8.00	22.50	62.50	.63
Ohio	138	2	69.0	1	1	2	4	2	2	4	2	10.00	44.00	16.00	24.00	94.00	.68
"	80	1	80.0	2	2	2	5	1	2	6	2	14.00	17.50	14.00	14.25	61.75	.77
Mo.	180	2	90.0	2	2	2	8	2	1	1	1	10.00	48.00	6.00	25.00	143.00	.80
"	131	5	26.2	4	4	5	3	5	1	1	1	30.00	30.00	17.50	17.00	94.50	.72
Ky.	211	5	42.2	1	1	2	7	2	1	2	1	12.00	45.00	4.00	24.00	225.00	1.06
Pa.	170	3	56.6	1	1	10	3	10	2	2	2	12.00	45.00	4.00	24.00	85.00	.50
"	228	10	22.8	1	1	10	3	10	2	2	2	12.00	45.00	4.00	24.00	85.00	.50

In preparing data for this booklet, the Universal Information Bureau has investigated during the past three years, about five hundred concrete silos of various types located in different parts of the United States. Methods of silo construction and operation were carefully studied and data on the actual cost and labor required, and other important information were obtained. Valuable assistance was received from a number of sources, particularly from the bulletins of the Department of Agriculture and the State Experiment Stations, several paragraphs from which have been used verbatim.

The reader seeking further information on the subject of silage and silo construction will find in the following pamphlets a comprehensive course of instruction:

- Cement Silos—Farmers' Bulletin No. 405, U. S. Department of Agriculture.
- Silos and Silage—Farmers' Bulletin No. 32, U. S. Department of Agriculture.
- Cost of Filling Silos—Farmers' Bulletin No. 292, U. S. Department of Agriculture.
- Concrete Silo Construction—Bulletin No. 214, University of Wisconsin, Madison, Wis.
- Cement Silos in Michigan—Bulletin No. 255, Michigan State Experiment Station, East Lansing, Michigan.
- Silage and the Construction of Modern Silos—Bulletin No. 83, Wisconsin Agricultural Experiment Station, Madison, Wisconsin.
- The Silo—Monthly Bulletin No. 2, Volume 6, Missouri State Board of Agriculture, Columbia, Missouri.
- The Reinforced Concrete Silo—Circular No. 49, by the Missouri Agricultural Experiment Station, Columbia, Mo.
- Concrete Silo Construction—Bulletin No. 6, Vol. IV, Kansas State Agricultural College, Manhattan, Kansas.
- Silos and Silage in Maryland—Bulletin No. 129, Maryland Agricultural Experiment Station, College Park, Maryland.
- The Silo and Silage in Indiana—Bulletin No. 40, Purdue Agricultural Experiment Station, LaFayette, Indiana.
- Soiling Crops, Silage and Roots—Bulletin No. 9, Series II, College of Agriculture, Cornell University, Ithaca, New York.
- “Modern Silage Methods,” published by the Silver Manufacturing Company, of Salem, Ohio.

Farmers' Bulletins published by the U. S. Department of Agriculture may be obtained by addressing J. A. Arnold, Editor and Chief Bureau of Publications—Department of Agriculture—Washington, D. C.



LIBRARY OF CONGRESS



0 002 766 090 3

