

Textile Mercury

Annuals

# The Cotton Year Book

1910.

TS1551  
C6

*R. O. Bonserant*

# LIBRARY





ESTABLISHED 1821

**PLATT BROTHERS & Co., LTD.**  
HARTFORD WORKS, OLDHAM, Eng.

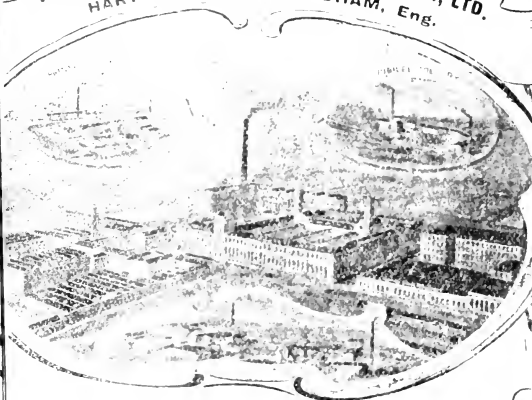

MAKERS OF  
ALL KINDS OF **TEXTILE MACHINERY** FOR  
COTTON, WOOL, WORSTED, and  
ASBESTOS



STRE  
STRE

Established 1790.

Telegraphic Address: "DOBSONS, BOLTON."

Codes used: A B C and LIEBER.

National Telephone No. 601.

# DOBSON & BARLOW, Ltd.

## BOLTON.

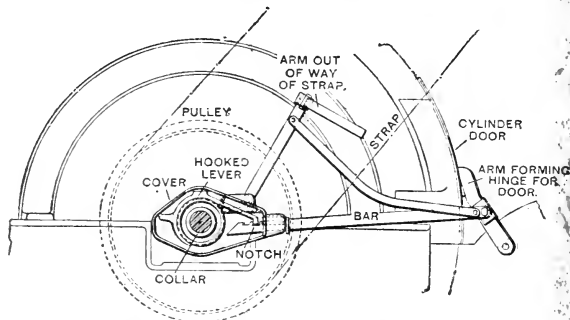

View Showing Door Closed.

### Improved Door-Locking Arrangement for Carding Engines.

#### ESSENTIAL FEATURES:—

Has been specially designed to conform to the requirements of the Factory and Workshops Act.

Makes it impossible for the cylinder cover to be opened before the cylinder has ceased to revolve.

The strap cannot be moved while the cover is open.

Simplicity in construction and not liable to get out of order.

Can be applied to all makes of carding engines.

#### MAKERS AND PATENTEES OF MACHINERY

For Preparing, Spinning, Doubling, Winding, Reeling, and Gassing Cotton; also of Machinery for Wool, Worsted, Silk, and Waste Yarns.

TS1551  
C6

ADVERTISEMENTS.

v.

# THE UNBREAKABLE PULLEY AND MILLGEARING CO., LTD.

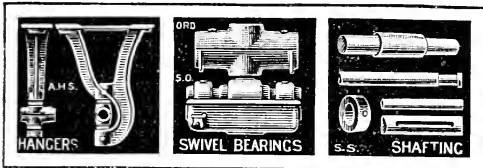

SHAFTING, PULLEYS, SWIVEL BEARINGS, AND EVERY VARIETY OF TRANSMISSION GEAR.

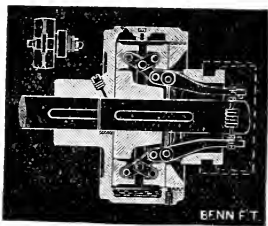
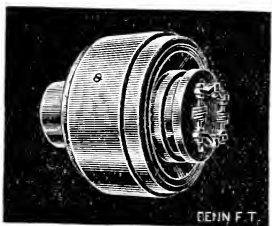

THE "BENN" PATENT FRICTION CLUTCH.  
—OVER 300,000 HORSE-POWER SOLD—



BIRCHES STREET, WEST GORTON, MANCHESTER.

Telephones:  
**7327** (Two Lines).

Telegrams:  
"STRENGTH, MANCHESTER."

LONDON: 56, CANNON STREET, E.C.

The compliment of imitation is not unknown to most men who have done things.

It is bitter-sweet.

But it is a compliment, none the less sincere because grudgingly given, even often unconsciously given.

When a maker says he can supply a belting equal to "Stretchless" at less cost, one immediately recognises the pious wish and the tacit acknowledgment of the qualities of "Stretchless."

We make "Stretchless."

To protect buyers, every length is stamped with the name and the world-known sign of this firm.

Registered



Trade Mark

HENRY F. COCKILL & SONS, Ltd.  
*Makers, CLECKHEATON.*

Export and General Sales Department:—

IMPERIAL BUILDINGS,

19, OLD MILLGATE,

MANCHESTER.

**HOWARD & BULLOUGH, Ltd., Accrington**

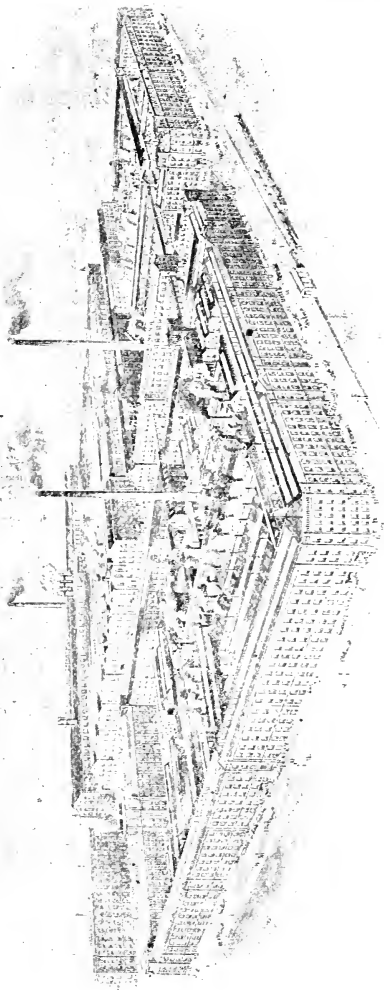

MAKERS OF

**OPENING, SCUTCHING, CARDING, COMBING, PREPARING, SPINNING,  
DOUBLING, & MANUFACTURING MACHINERY FOR COTTON.**

# GUM TRAGASOL

Is now being used in Warp Sizing for over

## 350,000 LOOMS.

**More Strength. More Elasticity. Less Dust.  
Greater Production. Superior Cloth.**

Also for Calico Printers, Cloth Finishers, etc., etc.

ENQUIRIES SOLICITED. WRITE FOR BOOKLET AND PARTICULARS.

**The Gum Tragasol Supply Company, Ltd.  
HOOTON, by CHESTER.**

# DOBBIES

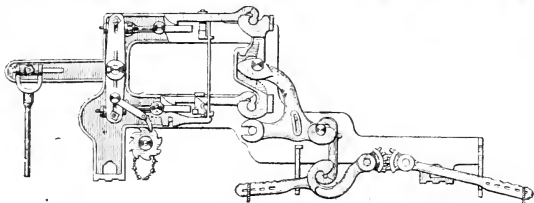

**WARD BROTHERS (Blackburn),  
LTD.  
BLACKBURN.**



Telegraphic Address: "ASA, OLDHAM." Codes Used: "A 1," "A B C," "Atlantic." National Telephone: No. 777, Oldham.

# ASA LEES & CO., LIMITED,

## Soho Iron Works, OLDHAM.

MANCHESTER OFFICE: Arcade Chambers, 14, St. Mary's Gate  
Open Tuesdays and Fridays.

MAKERS OF

## ALL KINDS OF MACHINERY

FOR

Ginning Cotton, Opening, Preparing, Combing,  
Spinning, and Doubling Cotton, Wool, Worsted, &c.

WINDING, GASSING, and BEAMING FRAMES.

COMPLETE PLANTS for Opening, Carding, and  
Spinning WASTE.

Agents for Continent of Europe :

Baerlein & Co., Manchester.

Agents for India :

Bradbury, Brady & Co., Churchgate Street, Fort, Bombay.  
Manchester Office : 16, John Dalton Street.

Agents for China :

Arnhold, Karberg & Co., London, Shanghai, Hong Kong, Canton,  
Hankow, and Tientsin.

Agents for Japan :

Samuel Samuel & Co., Ltd., Yokohama, Kobe, and Bakan.

Agents for U.S.A. and Canada :

William Firth Co., 79, Milk Street, Boston, Mass., U.S.A.

# JOHN MUSGRAVE & SONS

Limited,  
Globe Iron Works, **BOLTON.**

MAKERS OF

## High-class Horizontal & Vertical Steam Engines

Fitted with "Stegen Patent" Equilibrium Drop Piston Valves  
or Corliss Valves.

THE

## "Musgrave-Zoelly" Steam Turbine.

Over 500,000 H.P. of this type of Turbine at work.

### LOW STEAM CONSUMPTIONS.

Condensing Plants of all descriptions.

Pumping Plants to suit all conditions.

Air Compressors. Superheaters.  
Lancashire and Cornish Boilers.  
Water-tube Boilers.  
Travelling Cranes, &c., &c.

**MILLGEARING IN ALL ITS BRANCHES.**

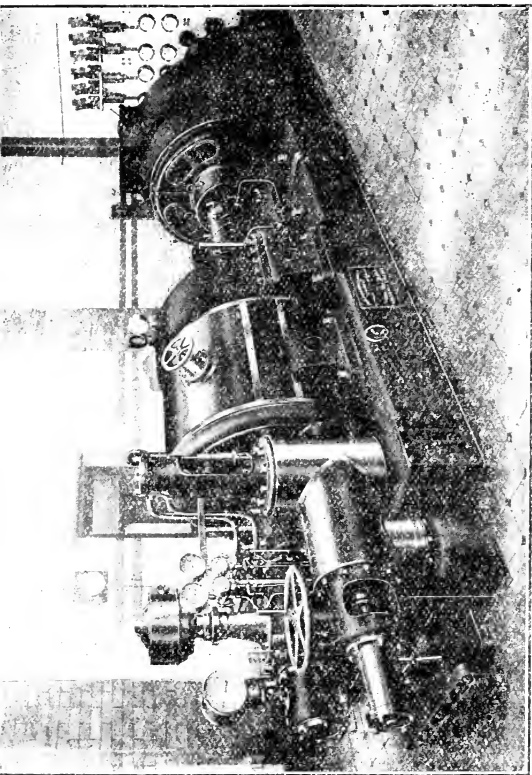

THE "MUSGRAVE-ZOELLY" STEAM TURBINE COUPLED DIRECT TO GENERATOR.

**JOHN MUSGRAVE & SONS, LTD., BOLTON.**

*Telegraphic and Cable Address: "MUSGRAVE, BOLTON."*

*Telephone No. 590 (3-lines).*

# MODERN MILLWRIGHTING

**Complete Equipments.**

**SHAFTING and Fittings.**

**PULLEYS—Belt and Rope.**

**FRICTION CLUTCHES.**

**BEARINGS—Every Description.**

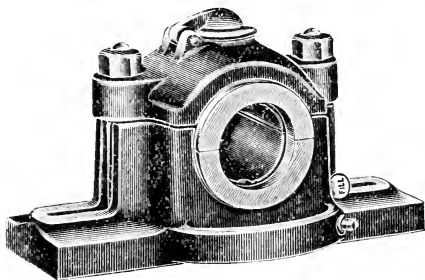

**RIGID OR SWIVELLING.**

**SOLID GREASE & OIL LUBRICATING.**

**Automatic and Positive Collar and Loose Ring Oiling.**

**ASK FOR OUR ILLUSTRATED CATALOGUES.**

# CROFT & PERKINS,

Limited,

Shafting Works,

# BRADFORD.

# Belt Driving at Right Angles

NO WHEELS. NO NOISE. NO DROPPING BELTS.

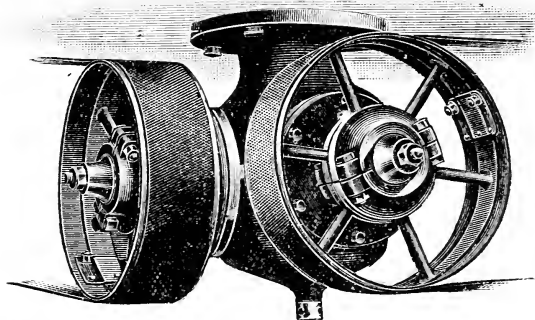

**PULLEYS,** all sizes,  
for **BELTS**  
or **ROPES.**

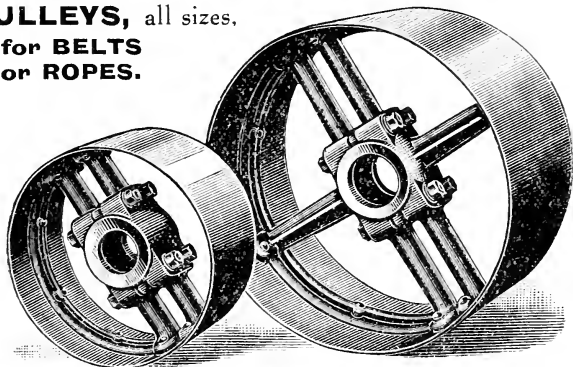

**CROFT & PERKINS, Ltd.** **SHAFTING**  
**BRADFORD.** **WORKS,**

ESTABLISHED 1823.

# Wilson Bros. Bobbin Co. Ltd.

## LIVERPOOL.

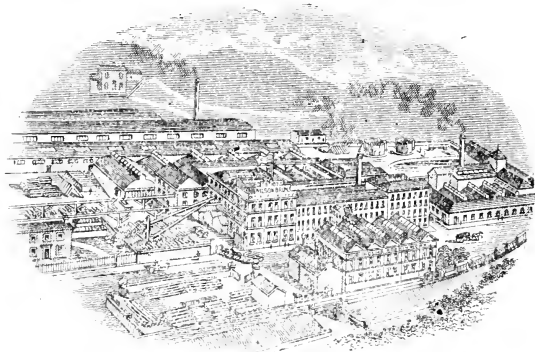

**SHUTTLE WORKS, TODMORDEN.**

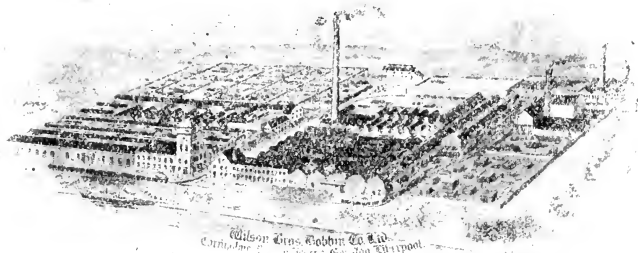

*Wilson Bros. Bobbin Co. Ltd.  
Circular Road, Liverpool.*

**WORKS AND HEAD OFFICES, LIVERPOOL.**

MAKERS OF

**RING TWIST AND WEFT BOBBINS**

With our Improved Shields and Tips.

**ENAMELLED BOBBINS A SPECIALITY.****Cardroom Tubes**

for Modern and Fine Spinning Mills.

Fitted with our Patent Serrated and "Grip" Shields.

**SPECIALISTS IN TIMBER SEASONING.**

Accuracy and Uniformity of Dimensions ensured.

N.B.—METAL PROTECTORS GUARANTEED  
ABSOLUTELY SECURE.**58 GOLD MEDALS 58  
AND DIPLOMAS.**

Showing a Continuity of Awards for over 50 years.

**Warping Bobbins**

With Endless Steel Tyres and Steel Plated Bush.

**Patent Self-Threading & Compact Shuttles.**

Telephone: 90, Garston. Telegrams: "NUGGET, LIVERPOOL."

Show Rooms: Imperial Buildings, Old Millgate, Manchester.  
Royal Exchange, No. 14 Pillar.

POSTAL ADDRESS:

**Cornholme Works, Garston, Liverpool.**

Telegraphic Address:  
 "ABBEY, Accrington."  
 Telephone No. 23.

Codes used:  
 A. B. C. (5th Edition), and  
 Western Union (Universal Edition).

# James Walmsley & Sons,

## ACCRINGTON, ENGLAND.

LEATHER CURRIERS, STRAPPING, Etc.  
 MANUFACTURERS.

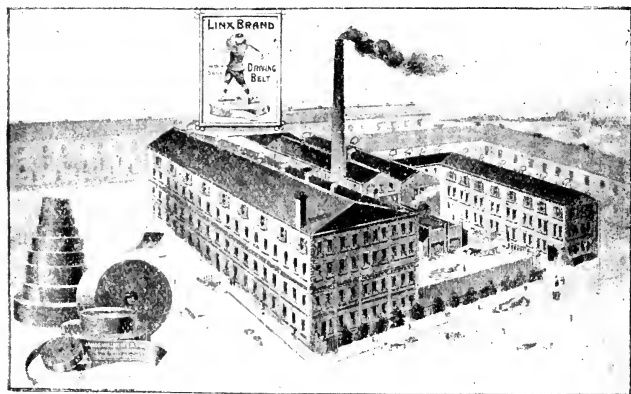

### SPECIALITIES:—

EXTRA STOUT MULE BELTING, SINGLE AND  
 DOUBLE BELTING.

ROLLER SKINS:

English, Welsh, and Persian.

PICKING BANDS:

Oak Tanned, Chrome, and Green.

Leather Pickers, Buffers, Laces (any kind), Buffalo Skips and  
 Pickers, and all other kinds of Leather Goods used in the Spinning  
 and Manufacturing of Cotton, Woollen, Silk, or Jute.

Factors of Cotton, Hair, Balata, and Rubber and Canvas Belting.



# WILLIAM SMITH & BROTHERS, <sup>Ltd.</sup>

**Sun Iron Works, HEYWOOD.**

*Telegraphic Address:*  
"SMITHS, Heywood."

*Telephone No. 2.*

ESTABLISHED

1824.

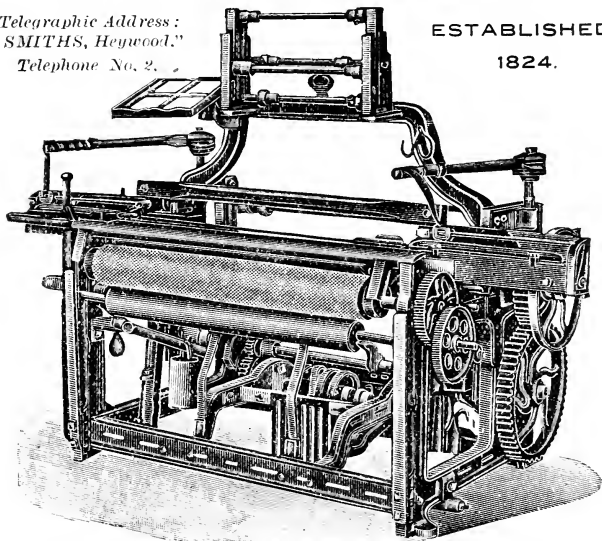

Looms of all descriptions for the Weaving of Cotton, Linen, Silk, Jute, Woollen, Hemp, etc.

Preparing Machinery for Winding, Warping, Dressing, Beaming, etc.

Sole Makers of Smith & Heyworth's Patent Drop Box Motion up to six boxes at each side, working pick and pick. Smith & Heyworth's Patent One Card One Box Motion. Smith & Heyworth's Patent Leno and Harness Loom, working up to 5 cover.

Carpet Machinery of all descriptions, and Looms up to 16 $\frac{1}{4}$  wide, with Smith & Hobson's Patent Wire Motion.

Printing Drums up to 70 feet circumference.

**Estimates and descriptive matter on application.**

# "BARNESLEY BOBBINS"

For the Spinning and Manufacture of  
Cotton, Wool, Silk, and all Textiles.

## SPECIALITIES.

TRADE MARK

"UNION  
IS  
STRENGTH."



"LOOSE  
SHIELDS  
WEAKNESS."

PATENT BARNESLEY "LOCKFAST," "CLIMAX" and "SIMPLEX"  
SHIELDS OR PROTECTORS,

FITTED BY US TO ALL TYPES OF BOBBINS,

ARE ABSOLUTELY & PERMANENTLY SECURE.

ENAMELLED CONDITIONING BOBBINS.  
Impervious to Steam, Moisture, or Oil.

Recent Highest Awards for Bobbins:—

"GRAND PRIZE," Franco-British Exhibition, London, 1908;  
Tourcoing, 1906; Liege, 1905; St. Louis, 1904.

Cable or Telegrams: "WILSON, BARNESLEY."

A1 and A B C Codes used.

Telephone :

No. 2 BARNESLEY.

# Wilson & Co. Barnsley, Ltd.

BARNESLEY, and 15, Market St., MANCHESTER.

**Correspond with BARNESLEY.**

## DIRECTORY OF MAKERS

Whose announcements of their Specialties appear in the  
Advertisement Pages.

### ASBESTOS MACHINERY—

Hattersley, Geo., & Sons, Ltd., Keighley.  
Larmuth, T., & Co., Ltd., Salford.  
Lord Bros., Ltd., Canal Street Works, Todmorden.  
Platt Bros. & Co., Ltd., Hartford Works, Oldham.  
Tomlinsons (Rochdale), Ltd., Soho Works, Rochdale.  
Tatham, Wm., and Co., Rochdale.

### ASBESTOS, SILICATE, Etc.—

Sutcliffe & Sutcliffe, Ltd., Texas Works, Manchester.

### BANDING (Spindle)—

Blakey, John H., Phoenix Mills, Radcliffe.

### BANDING AND BALLING MACHINES—

Larmuth, T., & Co., Ltd., Salford.

### BEAMS (Warpers and Weavers)—

Cort, Jos., Ltd., Blackburn.  
Henshall, W., & Sons, Barker Street, Oldham.

### BELTING MACHINERY—

Larmuth, T., & Co., Ltd., Salford.

### BELTING (Driving)—

Cockill, H. F., & Sons, Ltd., Cleckheaton.  
Reddaway, F., & Co., Ltd., Pendleton, Manchester.  
Sutcliffe & Sutcliffe, Texas Works, Manchester.  
Thompson, Geo., & Sons, Sowerby Bridge.  
Walmsley & Sons, Jas., Accrington.

### BLANKETS (Printers)—

Porritt Bror. and Austin, Ltd., Stubbins, Ramsbottom.

### BOBBINS AND TUBES (Wood)—

Dixon, John, & Sons, Steeton, Nr. Keighley.  
Livesey, Hy., Ltd., Blackburn.  
Wilson Bros. Bobbin Co., Ltd., Cornholme Works, Garston.  
Wilson & Co., Barnsley, Ltd., Beevor Works, Barnsley.

### BOILER COMPOSITIONS AND COVERINGS—

Emmott & Co., Signal Works, Stalybridge.  
Kenyon, W., & Sons, Ltd., Chapel Field Mills, Dukinfield.  
Moscrop, Thos., & Co., Ltd., Bolton.  
Sutcliffe & Sutcliffe, Texas Works, Manchester.

### BORING AND PUMPING MACHINERY—

Mather & Platt, Ltd., Salford Ironworks, Manchester.  
Matthews, Wm. A., & Co., Moston Lane, Manchester.

### BREAKING-UP MACHINE LAGS—

Schirp, H., Barmen, Germany.

### BREAKING-UP MACHINES (Waste)—

Tatham, Wm., & Co., Vulcan Works, Rochdale.  
Tomlinsons (Rochdale), Ltd., Soho Ironworks, Rochdale.

### BRUSHES (Mill, Etc.)—

Brushes, Ltd., Ashton and Oldham.  
Philipson & Co., Astley Bridge, Bolton.

LIBRARY

# The Walrus Fibre Mfg. Co.,

Speciality: SEAMLESS Fibre Cans. LIMITED.

Roe Head,  
Mirfield.

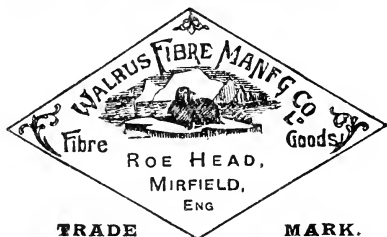

Works:  
Florence St.  
Mill,  
ROCHDALE.

TRADE MARK.

## SLIVER AND CORDAGE CANS

FOR COTTON, WORSTED, FLAX, ROPE, AND  
JUTE SPINNING.

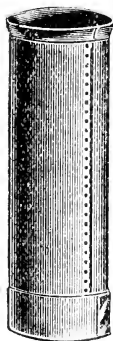

## TRUCKS & BOXES.

Special Features:

**Lightness**  
and  
**Durability.**

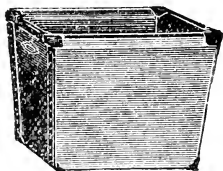

Full Particulars, Prices, &c., on application.

Telegraphic Address:  
"LISTERS, MIRFIELD."

Telephones:  
Mirfield No. 1. Rochdale No. 239.

 All communications to be addressed to ROE HEAD, MIRFIELD.

DIRECTORY OF MAKERS—*Continued.***BUNDLING PRESSES (Yarn)—**

Arundel & Co., Sovereign Works, Stockport.  
Brooks & Doxey, Ltd., Union Ironworks, Manchester.  
Dobson & Barlow, Ltd., Kay Street Works, Bolton.  
Hattersley, Geo., & Sons, Ltd., Keighley.  
Holt & Kirk, Ltd., Oldham.  
Holt, Thos., Ltd., Atlas Works, Rochdale.  
Stubbs, Joseph, Mill Street Works, Manchester.

**CABLE COVERING MACHINERY—**

Larmuth, T., & Co., Ltd., Salford.

**CANS (Sliver)—**

Noton, S., & Sons, Oldham.  
Walrus Fibre Manufacturing Co., Ltd., Mirfield, Yorks.

**CARD-CUTTING MACHINES (Jacquard)—**

Hattersley, Geo., & Sons, Ltd., Keighley.  
McMurdo, James, Miles Platting, Manchester.

**CASTING (Sheet Metal)—**

Jagger, E., & Co., Werneth, Oldham.  
Kenyon, Wm., & Sons, Ltd., Chapel Field Mills, Dukinfield.  
Robinson, B., & Co., Bark Street, Bolton.

**CHAIN MAKERS—**

Larmuth, T., & Co., Ltd., Salford.

**CHEMICALS—**

United Alkali Co., Ltd., James Street, Liverpool.

**CLOTH EXPANDERS—**

Bentley & Jackson, Ltd., Lodge Bank Works, Bury.  
Mather & Platt, Ltd., Salford Ironworks, Manchester.

**CLOTH PRESSES—**

Baldwin & Heap, Ltd., Bethesda Works, Burnley.  
Keighley, Geo., Ltd., Burnley.  
Livesey, Hy., Ltd., Blackburn.

**CLOTH RAISING MACHINES—**

Tomlinsons (Rochdale), Ltd., Soho Works, Rochdale.

**CLUTCHES (Driving)—**

Bridge, David, & Co., Castleton, near Rochdale.  
Unbreakable Pulley Co., Ltd., West Gorton, Manchester.

**CONDENSERS—**

Mather & Platt, Ltd., Salford Ironworks, Manchester.  
Royles, Ltd., Irlam, Nr. Manchester.

**CONDITIONING MACHINES—**

Tomlinsons (Rochdale), Ltd., Soho Ironworks, Rochdale.  
Wray, G. & A., Alexandra Shed, Keighley.

**CONSULTING ENGINEERS—**

Cook, W. H., Longsight, Manchester.  
Ecroyd, S., 5, Carr Street, Manchester.

**COUNTERS (Speed)—**

Orme, Geo., & Co., Atlas Meter Works, Oldham.  
Thomas, Geo., & Co., Parsonage Lane, Manchester.

# E. JAGGER & CO., Werneth Metal Factory OLDHAM.

National Telephone : 155 Oldham.  
Manchester Exchange, 16 Pillar, Tuesdays and Fridays.

PATENTEES AND SOLE MAKERS OF JAGGER'S

## Patent Portable Cop Tubing Apparatus,

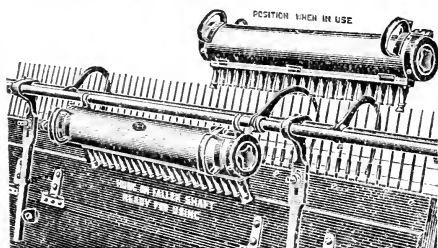

For placing Paper  
and other Tubes on  
the Spindles of  
Mules, Twiners,  
etc., with  
rapidity and accuracy.

Accessories and Appliances of all kinds for  
Textile Machinery, also

**TINPLATE & GENERAL SHEET METAL WORKERS,  
STAMPERS, PIERCERS, &c.**

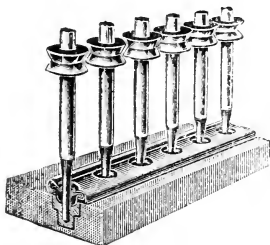

Improved Measuring Oilers,  
and Extraction Pumps  
for Ring Frame Spindles.

Patent Spindle Footstep  
Protectors and Lubricators.

Over 50% of Oil saved.  
Millions in use.

And numerous other specialities in textile appliances.

DIRECTORY OF MAKERS—*Continued.***CRANE MAKERS—**

Larmuth, T., & Co., Ltd., Salford.

**DOBBIES—**

Hattersley, Geo., & Sons, Ltd., Keighley.

Keighley, Geo., Ltd., Burnley.

Livesey, Hy., Ltd., Blackburn.

Smith, Wm., & Bros., Ltd., Heywood.

Ward Bros. (Blackburn), Ltd., Blackburn.

**DOUBLING WINDING—**

Arundel & Co., Stockport.

Brooks & Doxey, Ltd., Union Ironworks, Manchester.

Dobson & Barlow, Ltd., Kay Street Works, Bolton.

Holt, Thos., Ltd., Atlas Works, Rochdale.

International Winding Co., Saville Street, Manchester.

Larmuth, T., & Co., Ltd., Salford.

Platt Bros. & Co., Ltd., Hartford Works, Oldham.

Stubbs, Joseph, Mill Street Works, Manchester.

**DRESSING FRAMES (Yarn)—**

Holt, Thos., Ltd., Atlas Works, Rochdale.

Platt Bros. & Co., Ltd., Hartford Works, Oldham.

Hattersley, Geo., & Sons, Ltd., Keighley.

**DRYING, CALENDERING, Etc. (Bleachers)—**

Bentley & Jackson, Ltd., Lodge Bank Works, Bury.

Mather & Platt, Ltd., Salford Ironworks, Manchester.

**DRYING MACHINERY (Yarn)—**

Bentley & Jackson, Ltd., Lodge Bank Works, Bury.

Fielden & Co., Ainsworth Street Works, Rochdale.

Keith, J., & Blackman Co., Ltd., London.

Mather & Platt, Ltd., Salford Ironworks, Manchester.

Tattersall & Holdsworth, Burnley and Enschede.

Tomlinsons (Rochdale), Ltd., Soho Works, Rochdale.

Whiteley, Wm., & Sons, Ltd., Huddersfield.

**DUST REMOVING APPARATUS—**

Smethurst, The H., Ventg. & Eng. Co., Ltd., Hollinwood.

Stott, J., & Co., Vernon Works, Oldham.

**ECONOMISERS (Fuel)—**

Clay Cross Co., Chesterfield.

**ELECTRIC DRIVING AND LIGHTING—**

Greenwood & Batley, Ltd., Leeds.

Mather & Platt, Ltd., Salford Ironworks, Manchester.

**EMERY FILLETING, Etc.—**

Chadwick, Cobden, Oldham.

Wareing, Thos., & Co., Rochdale.

**ENGINES (Steam)—**

Baldwin & Heap, Ltd., Bethesda Street, Burnley.

Musgrave, John, & Sons, Ltd., Bolton.

Pollit & Wigzell, Ltd., Sowerby Bridge.

Saxon, Geo., Ltd., Openshaw, Manchester.

Scott & Hodgson, Ltd., Guide Bridge.

Wainwright, Thos., & Sons, Ltd., Stalybridge.

*Royles Limited*

**ENGINEERS and  
SPECIALISTS,**

**IRLAM, near  
MANCHESTER.**

Solicit your Enquires for

**ROYLE'S PATENT COMBINED  
REDUCING SAFETY VALVES,**

Absolutely Safe and Reliable.

**SYPHONIA STEAM TRAPS,  
AUTOMATIC WITHOUT ADJUSTING  
AT ALL PRESSURES.**

**OVER 100,000 IN USE.**

**ALSO LIFTING & FULLWAY TRAPS.**

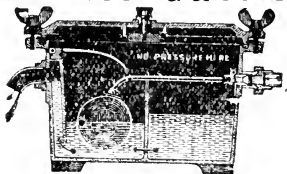

MANCHESTER  
ROYAL  
EXCHANGE,  
PILLAR 14.

**ROW'S PATENT TUBE  
FOR  
STEAM KETTLES. FEED WATER  
HEATERS. CONDENSERS.  
BOILING BATTERIES for Kiers, Yats, &c.**

We are Specialists in  
**WATER SOFTENING AND FILTERING**  
Pure Water guaranteed for Boilers and  
Textile Purposes.

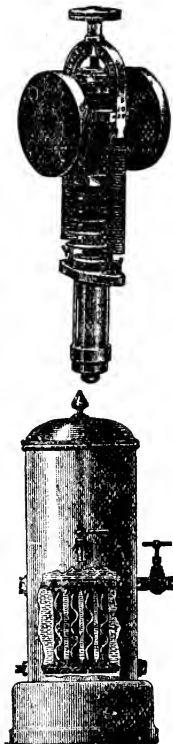



DIRECTORY OF MAKERS—*Continued.***ENGINE AND BOILER FITTINGS—**

White, W. H., Hyde.

**FANS AND BLOWERS—**

Keith, J., & Blackman Co., Ltd., London.  
Mather & Platt, Ltd., Salford Ironworks, Manchester.  
Stott, Jas., & Co., Vernon Works, Oldham.

**FILTRATION—**

Mather & Platt, Ltd., Salford Ironworks, Manchester.  
Royles, Ltd., Irlam, Nr. Manchester.

**FIRE APPLIANCES—**

Reddaway, F., & Co., Ltd., Pendleton, Manchester.

**GASSING FRAMES—**

Arundel & Co., Stockport.  
Dobson & Barlow, Ltd., Kay Street Works, Bolton.  
Lees, Asa, and Co., Ltd., Soho Ironworks, Oldham.  
Stubbs, Joseph, Mill Street Works, Manchester.

**GAS GOVERNORS—**

Stott, Jas., & Co., Vernon Works, Oldham.

**GAS PRODUCING PLANT—**

Mather & Platt, Ltd., Salford Ironworks, Manchester.

**GINS (Cotton)—**

Dobson & Barlow, Ltd., Kay Street Works, Bolton.  
Lees, Asa, & Co., Ltd., Soho Ironworks, Oldham.  
Platt Bros. & Co., Ltd., Hartford Works, Oldham.

**GREASE AND OTHER LUBRICANTS—**

Emmott & Co., Signal Works, Stalybridge.  
Sutcliffe & Sutcliffe, Texas Works, Manchester.

**HEADS AND REEDS (Loom)—**

Jones Bros., Ltd., Pioneer Works, Blackburn.

**HEATERS (Air)—**

Royles, Ltd., Irlam, Nr. Manchester.

**HOISTS, Etc.—**

Baldwin & Heap, Ltd., Bethesda Works, Burnley.

**INDICATORS (Hank, Speed, Etc.)—**

Orme, Geo., & Co., Atlas Meter Works, Oldham.

**JACQUARDS—**

Hattersley, Geo., & Sons, Ltd., Keighley.  
McMurdo, Jas., Miles Platting, Manchester.

**HOSE PIPING—**

Reddaway, F., & Co., Ltd., Pendleton, Manchester.

**LAGS, ETC. (Dobby)—**

Jones Bros., Ltd., Pioneer Works, Blackburn.

**LAMP AND CANDLE WICK MACHINERY—**

Larmuth, T., & Co., Ltd., Salford.

**LUBRICATORS—**

Croft & Perkins, Ltd., Bradford.

# JOHN DIXON & SONS,

Bobbin Manufacturers,  
Established 1795.

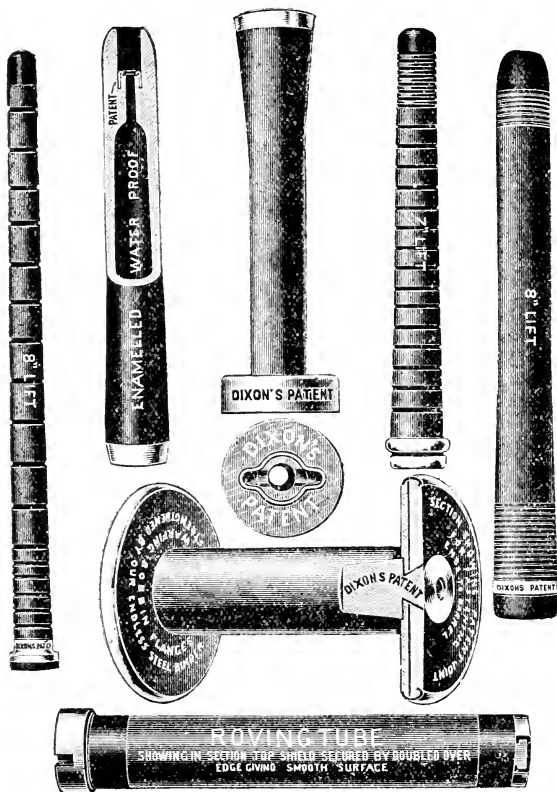

## STEETON, near KEIGHLEY

Attendance { Manchester Exchange, Tuesday and Friday.  
Bradford Exchange, Monday and Thursday.

DIRECTORY OF MAKERS—*Continued.***MACHINERY (Bleaching)—**

Bentley & Jackson, Ltd., Lodge Bank Works, Bury.  
Knowles & Co., Globe Works, Bradford.  
Mather & Platt, Ltd., Salford Ironworks, Manchester.  
Whiteley, Wm., & Sons, Ltd., Huddersfield.

**MACHINERY (Carding and Preparing)—**

Brooks & Doxey, Ltd., Union Ironworks, Manchester.  
Dobson & Barlow, Ltd., Kay Street Works, Bolton.  
Hetherington, J., & Sons, Ltd., Vulcan Ironworks, M/c.  
Howard & Bullough, Ltd., Globe Works, Accrington.  
Knowles & Co., Bradford.  
Lees, Asa, & Co., Ltd., Soho Ironworks, Oldham.  
Lord Bros., Ltd., Canal Street Works, Todmorden.  
Platt Bros. & Co., Ltd., Hartford Works, Oldham.  
Tatham, Wm., & Co., Rochdale.  
Taylor, Lang, & Co., Ltd., Castle Ironworks, Stalybridge.  
Tweedales & Smalley, Ltd., Globe Works, Castleton.

**MACHINERY (Combing)—**

Dobson & Barlow, Ltd., Kay Street Works, Bolton.  
Hetherington, J., & Sons, Ltd., Vulcan Ironworks, M/c.  
Howard & Bullough, Ltd., Accrington.  
Lees, Asa, & Co., Ltd., Soho Ironworks, Oldham.  
Platt Bros. & Co., Ltd., Hartford Works, Oldham.

**MACHINERY (Cotton Waste)—**

Brooks & Doxey, Ltd., Union Ironworks, Manchester.  
Dobson & Barlow, Ltd., Kay Street Works, Bolton.  
Hetherington, J., & Sons, Ltd., Vulcan Ironworks, M/c.  
Lees, Asa, & Co., Ltd., Soho Ironworks, Oldham.  
Lord Bros., Ltd., Canal Works, Todmorden.  
Platt Bros. & Co., Ltd., Hartford Works, Oldham.  
Tatham, Wm., & Co., Rochdale.  
Taylor, Lang, & Co., Ltd., Castle Ironworks, Stalybridge.  
Tomlinsons (Rochdale), Ltd., Soho Works, Rochdale.  
Tweedales & Smalley, Ltd., Castleton.

**MACHINERY (Mercerising)—**

Bentley & Jackson, Ltd., Lodge Bank Works, Bury.  
Holt, Thos., Ltd., Atlas Works, Rochdale.  
Knowles & Co., Bradford.  
Mather & Platt, Ltd., Salford Ironworks, Manchester.  
Whiteley, Wm., & Sons, Ltd., Huddersfield.

**MACHINERY (Openers and Scutchers)—**

Brooks & Doxey, Ltd., Union Ironworks, Manchester.  
Dobson & Barlow, Ltd., Kay Street Works, Bolton.  
Hetherington, J., & Sons, Ltd., Vulcan Ironworks, M/c.  
Howard & Bullough, Ltd., Globe Works, Accrington.  
Lees, Asa, & Co., Ltd., Soho Ironworks, Oldham.  
Lord Bros., Ltd., Canal Street Works, Todmorden.  
Platt Bros. & Co., Ltd., Hartford Works, Oldham.  
Taylor, Lang, & Co., Ltd., Castle Ironworks, Stalybridge.

Contractors to  
H.M. Government.

National Telephone No. 21.  
Manchester Exchange, No. 12 Pillar.

# PETER PILKINGTON, Ltd.

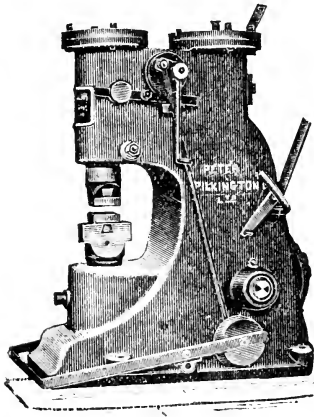

These Power Hammers are specially adapted for cotton mill work. We make them with 8 in. and 12 in. stroke to deal with 2 in. and 3 in. material respectively. They possess features entirely novel and distinct from all other hammers.

The hammer head or tup starts or leaves off work instantly at the will of the operator. The control of the air between the tup cylinder and air pump cylinder is effected by a very simple valve actuated by either a hand lever or foot treadle, as are also the weight of the blows.

The Hammer is entirely self-contained, simple to work, and has been specially constructed to fulfil the requirements of a blacksmith's shop.

Also Makers of

Compound Pneumatic Hammers  
from 1 cwt. to 60 cwt. capacity.

∴ AIR COMPRESSORS. ∴

Works and Head Offices:

## Bamber Bridge, nr. Preston.

## DIRECTORY OF MAKERS—Continued.

### MACHINERY (Ring Spinning and Doubling)—

Brooks & Doxey, Ltd., Union Ironworks, Manchester.  
 Dobson & Barlow, Ltd., Kay Street Works, Bolton.  
 Hetherington, J., & Sons, Ltd., Vulcan Ironworks, M/c.  
 Howard & Bullough, Ltd., Globe Works, Accrington.  
 Lees, Asa, & Co., Ltd., Soho Ironworks, Oldham.  
 Lord Bros., Ltd., Canal Street Works, Todmorden.  
 Platt Bros. & Co., Ltd., Hartford Works, Oldham.  
 Taylor, Lang, & Co., Ltd., Castle Ironworks, Stalybridge.  
 Tweedales & Smalley, Ltd., Globe Works, Castleton.

### MACHINERY (Weaving)—

Hattersley, Geo., & Sons, Ltd., Keighley.  
 Keighley, Geo., Ltd., Burnley.  
 Livesey, Hy., Ltd., Blackburn.  
 Platt Bros. and Co., Ltd., Werneth, Oldham.  
 Smith, Wm., & Bros., Ltd., Heywood.

### MILL FURNISHERS—

Noton, T., Grange Works, Oldham.  
 Sutcliffe & Sutcliffe, Parsonage, Manchester.

### MILL GEARING—

Bridge, David, & Co., Castleton.  
 Croft & Perkins, Ltd., Bradford.  
 Mather & Platt, Ltd., Salford Ironworks, Manchester.  
 Musgrave, John, & Sons, Ltd., Bolton.  
 Pollit & Wigzell, Ltd., Sowerby Bridge.  
 Saxon, Geo., Ltd., Openshaw, Manchester.  
 Scott & Hodgson, Ltd., Guide Bridge.  
 Thompson, G., & Sons, Sowerby Bridge.  
 Unbreakable Pulley Co., Ltd., Birches St., W. Gorton, M/c.  
 Wainwright, Thos., & Sons, Ltd., Canal Street, Stalybridge.

### METAL MERCHANTS—

Bennett, J. J., 88, Mosley Street, Manchester.

### MOISTENING APPARATUS (Yarn)—

British Humidifier Co., Ltd., Blackburn.

### MULES (Spinning and Doubling)—

Dobson & Barlow, Ltd., Kay Street Works, Bolton.  
 Hetherington, J., & Sons, Ltd., Vulcan Ironworks, M/c.  
 Howard & Bullough, Ltd., Globe Works, Accrington.  
 Lees, Asa, & Co., Ltd., Soho Ironworks, Oldham.  
 Platt Bros. & Co., Ltd., Hartford Works, Oldham.  
 Taylor, Lang, & Co., Ltd., Castle Ironworks, Stalybridge.  
 Whiteley, Wm., & Sons, Ltd., Huddersfield.

### PACKING (Steam)—

Sutcliffe & Sutcliffe, Texas Works, Manchester.  
 United States Metallic Packing Co., Ltd., Bradford.

### PAINTS, OILS, ETC.—

Moscrop, T., & Co., Ltd., St. George Street, Bolton.

### PAPER TUBES, Etc.—

Holgate, W., & Sons (Oldham), Ltd., Oldham.  
 Swailes, John, and Sons, Ltd., Moorhey, Oldham.

### PAPER TUBE MACHINERY—

Swailes, John, & Sons, Ltd., Moorhey, Oldham.

# DYEING & BLEACHING MACHINERY.

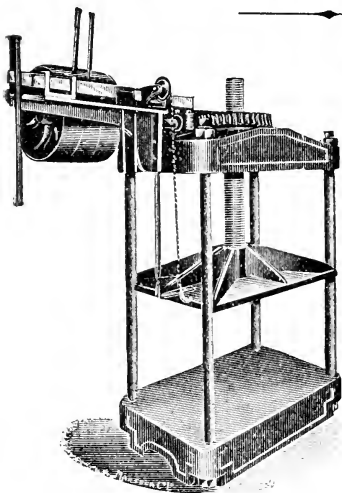

BALING PRESS.

SHAFTING AND ALL ACCESSORIES.

## Engines

For all  
TEXTILE MACHINES.

## Hoists.

Cage Hoists.  
Self-Landing and  
Self-Delivering Hoists.  
Friction Hoists.

## Cloth Presses.

## Baling Presses.

# BALDWIN & HEAP, LTD.

Textile Works,

## BURNLEY, Lancs.

England.

DIRECTORY OF MAKERS—*Continued.***PATENT AGENTS—**

Tasker & Crossley, George Square, Halifax.

**PICKER MACHINERY—**

Larmuth, T., & Co., Ltd., Salford.

**POWER HAMMERS—**

Pilkington, Peter, Ltd., Bamber Bridge, Nr. Preston.

**POWER AND SPEED TESTING APPARATUS—**

Thomas, Geo., & Co., Manchester.

**PREPARING MACHINES (Yarn)—**

Arundel & Co., Sovereign Works, Stockport.

Larmuth, T., & Co., Ltd., Salford.

Stubbs, Jos., Mill Street Works, Manchester.

**PRESSES (Fibre)—**

Larmuth, T., & Co., Ltd., Salford.

**PUMPS—**

Baldwin & Heap, Ltd., Burnley.

Mather & Platt, Ltd., Salford Ironworks, Manchester.

Matthews, Wm. A., & Co., Moston Lane, Manchester.

**RAISING MACHINES (Cloth)—**

Tomlinsons, Ltd., Soho Ironworks, Rochdale.

**RAMIE MACHINERY—**

Larmuth, T., & Co., Ltd., Salford.

**REELING MACHINES—**

Arundel & Co., Stockport.

Hattersley, Geo., & Sons, Ltd., Keighley.

Hetherington, J., & Sons, Ltd., Vulcan Ironworks, M/c.

Holt & Kirk, Ltd., Oldham.

Holt, Thos., Ltd., Atlas Works, Rochdale.

Platt Bros. & Co., Ltd., Hartford Works, Oldham.

Schofield, Wm., Rosehill Works, Oldham.

Stubbs, Joseph, Mill Street Works, Manchester.

**REED MACHINERY—**

Larmuth, T., & Co., Ltd., Salford.

**RING FRAME TRAVELLERS—**

Brooks & Doxey, Ltd., Union Ironworks, Manchester.

Cook & Co., 18, Exchange Street, Manchester.

Coulthard, T., & Co., Ltd., Cooper Road, Preston.

**RINGS (Spinning and Doubling)—**

Brooks & Doxey, Ltd., Union Ironworks, Manchester.

Cook & Co., 18, Exchange Street, Manchester.

Coulthard, T., & Co., Ltd., Cooper Road, Preston.

Dobson & Barlow, Ltd., Kay Street Works, Bolton.

Howard & Bullough, Ltd., Globe Works, Accrington.

**ROLLER AND CLEARER CLOTH—**

Kenyon, J., & Sons, Bury.

Porritt Bror. and Austin, Ltd., Stubbins, Ramsbottom.

**ROLLER COVERING MACHINERY—**

Chadwick Cobden, Century Works, Oldham.

**ROLLER LEATHER—**

Roberts, John, & Co., Stockport.

Walmsley, James, & Sons, Accrington

HEYWOOD &amp; BRIDGE'S

# Patent Friction Clutches

And COMPLETE SHAFTING, PULLEY, and GEARING  
INSTALLATIONS, for COTTON MILLS, WORKS, &c.

N.B.—Competition becomes keener every year, but there are many leakages yet which will enable you to hold your own. Adopt our Clutches for stopping any shaft or section of your mill or works when not required, also connect and disconnect your machinery by the same method.

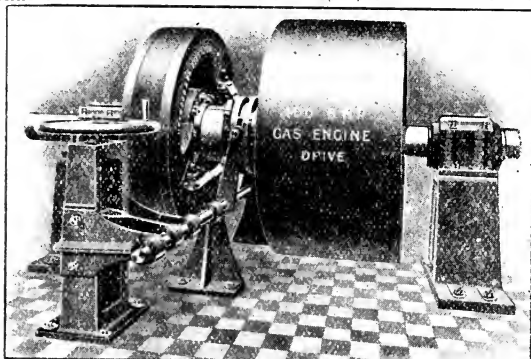

Our Clutches stop and start the heaviest of loads without any shock or jar when running at full speed.

Thousands Working. Hundreds of Repeat Orders.

200-PAGE CATALOGUE FREE, containing Prices, Dimensions, and useful Rules and Information.

## RUBBER MACHINERY in all its Branches.

Patentees and Sole Makers:

**DAVID BRIDGE & CO.,** *Engineers,*  
Fylde Works,  
CASTLETON, MANCHESTER.



DIRECTORY OF MAKERS—*Continued.*

**ROLLERS (Fluted, Etc.)—**

Longworth, Wm., & Sons, Ltd., Bolton.  
Lupton Bros., Ltd., Accrington.

**ROPES (Driving)—**

Keryon, Wm., & Sons, Chapel Field Works, Dukinfield.

**ROPE MACHINERY—**

Larmuth, T., & Co., Ltd., Salford.

**RUBBER MACHINERY—**

Bridge, David, & Co., Castleton, Manchester.

**SCUTCHER GRIDS—**

The Rob. Shaellibaum Co., 67, Hanging Ditch, Manchester.

**SHUTTLES—**

Wilson Bros. Bobbin Co., Ltd., Cornholme Works, Garston.

**SILK MACHINERY—**

Greenwood & Batley, Ltd., Leeds.  
Hattersley, Geo., & Sons, Ltd., Keighley.  
Mather & Platt, Ltd., Salford Ironworks, Manchester.  
Platt Bros. & Co., Ltd., Hartford Works, Oldham.  
Smith, Wm., & Bros., Ltd., Heywood.  
Tomlinsons (Rochdale), Ltd., Soho Works, Rochdale.

**SIZING MACHINES—**

Howard & Bullough, Ltd., Globe Works, Accrington.  
Keighley, Geo., Ltd., Burnley.  
Knowles & Co., Bradford.  
Livesey, Hy., Ltd., Blackburn.  
Platt Bros. & Co., Ltd., Hartford Works, Oldham.  
Smith, Wm., & Bros., Ltd., Heywood.  
Tattersall & Holdsworth, Burnley and Enschede.

**SIZE MIXING APPARATUS—**

Livesey, Hy., Ltd., Greenbank Ironworks, Blackburn.  
Tattersall & Holdsworth, Burnley and Enschede.

**SIZING MATERIALS—**

Gum Tragasol Supply Co., Ltd., Hooton.

**STRETCHING MACHINES (Banding)—**

Cook & Co., 18, Exchange Street, Manchester.  
Larmuth, T., & Co., Ltd., Salford.

**SKIPS—**

Abbatt, Wm., & Co., Albion Cane Works, Bolton.

**SMALLWARE MACHINERY—**

Hattersley, Geo., & Sons, Ltd., Keighley.  
Larmuth, T., & Co., Ltd., Salford.

**SPINDLE MAKERS—**

Bodden, Wm., & Sons, Ltd., Hargreaves Works, Oldham.  
Brooks & Doxey, Ltd., Union Ironworks, Manchester.  
Coulthard, T., & Co., Ltd., Cooper Road, Preston.  
Dobson & Barlow, Ltd., Kay Street Works, Bolton.  
Hattersley, Geo., & Sons, Ltd., Keighley.  
Hetherington, J., & Sons, Ltd., Vulcan Ironworks, M/c.  
Holt & Kirk, Ltd., Oldham.  
Howard & Bullough, Ltd., Globe Works, Accrington.  
Lees, Asa, & Co., Ltd., Soho Ironworks, Oldham.  
Moss, W., & Sons, Carr Spindle Works, Stockport.  
Platt Bros. & Co., Ltd., Hartford Works, Oldham.  
Tweedales & Smalley, Ltd., Globe Works, Castleton.

**WINDING,  
WARPIING,  
AND  
REELING  
MACHINERY.**



**THOMAS HOLT, LTD.**

**Atlas Iron Works,**

**WHITWORTH RD., ROCHDALE.**

TELEPHONE No. 122.    TELEGRAMS: "ATLAS." ROCHDALE.

ATTENDANCE AT BRADFORD EXCHANGE, MONDAY and THURSDAY.  
MANCHESTER ROYAL EXCHANGE, No. 6 PILLAR, TUESDAY and FRIDAY.

DIRECTORY OF MAKERS—*Continued.***SPLIT MOTIONS (Loom)—**

Fairburn, John, Queen Street Mill, Burnley.

**SPRINGS, ETC. (Loom)—**

Cook, Saml., & Co., Bury.

**SPRINKLERS—**

Mather & Platt, Ltd., Salford Ironworks, Manchester.

Newton, Chambers, & Co., Ltd., 10, Walbrook, London, E.C.

**STAMPING MACHINES (Cloth)—**

Bentley & Jackson, Ltd., Bury.

**STEAM TRAPS—**

Royles, Ltd., Irlam, Nr. Manchester.

**STRIPPERS (Card Flat)—**

Philipson & Co., Bolton.

**TEMPLES (Loom)—**

Fairburn, J., Queen Street Mill, Burnley.

Lupton Bros., Ltd., Accrington.

**THREAD GUIDES (Ring Frame)—**

Cook & Co., 18, Exchange Street, Manchester.

Coulthard, T., & Co., Ltd., Preston.

Tytler & Bowker's Patent (of all Machinists).

**TIN PLATE WORKERS—**

Jagger, E., & Co., Werneth, Oldham.

Robinson, B., & Co., Bark Street, Bolton.

Smethurst, The H., Ventg. & Eng. Co., Ltd., Hollinwood.

**TRAVERSE MOTIONS (Variable)—**

Brooks & Doxey, Ltd., Union Ironworks, Manchester.

Coulthard, T., & Co., Ltd., Cooper Road, Preston.

Dobson & Barlow, Ltd., Kay Street Works, Bolton.

Tatham, Wm., & Co., Rochdale.

**TUBING APPARATUS (for Mules)—**

Holgate, Wm., & Sons, Ltd., Phoenix Works, Oldham.

Jagger, E., & Co., Oldham.

Swales, Jno., & Sons, Ltd., Moorhey, Oldham.

**TURBINES (Steam)—**

Greenwood & Batley, Ltd., Albion Works, Leeds.

Mather & Platt, Ltd., Salford Ironworks, Manchester.

Wainwright, Thos., & Sons, Ltd., Stalybridge.

**TWINE AND BANDING—**

Blakey, J. H., Phoenix Mills, Radcliffe.

**TWINE AND CORD MACHINERY—**

Larmuth, T., & Co., Ltd., Salford.

**VALVES (Reducing Steam)—**

Royles, Ltd., Irlam, Nr. Manchester.

**VENTILATING, HEATING, Etc.—**

Keith, J., & Blackman Co., Ltd., London.

Mather & Platt, Ltd., Salford Ironworks, Manchester

Stott, J., & Co., Vernon Works, Oldham.

**WADDING MACHINERY—**

Hetherington, J., & Sons, Ltd., Vulcan Ironworks, M/c.

Lees, Asa, & Co., Ltd., Oldham.

Lord Bros., Ltd., Todmorden.

Tatham, W., & Co., Rochdale.

Tomlinsons (Rochdale), Ltd., Soho Works, Rochdale.

# PATENT SPLIT-DRUM Vertical Burner Gassing Frame

With Patent Ventilating Arrangement.

MAKERS OF

Ring and Flyer  
Doubling Frames.

Winding and  
Clearing Frames.

Patent Gassing  
Frames.

Patent Doubling  
Winding Frames.

Preparing Machines.

MAKERS OF

Reels.

Warping Machines.

Bundling Presses.

Patent Tapering  
Motions.

Moscrop Recorders.

Patent Yarn  
Clearers

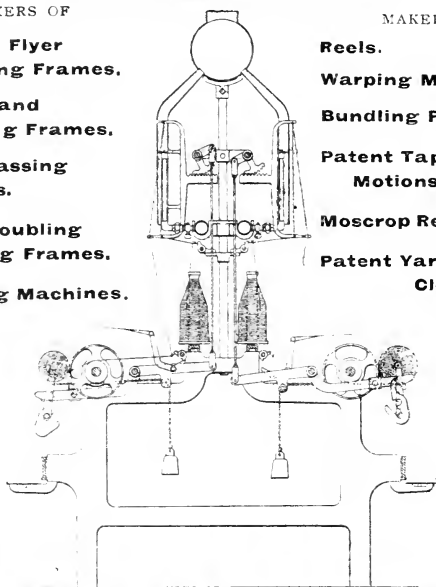

# ARUNDEL & Co.

SOVEREIGN WORKS,

Manchester Exchange:  
Tuesdays and Fridays,  
No. 14 Pillar.

## STOCKPORT.

Telegrams: "ARUNDEL, Stockport."

Telephone No. 348

---

 DIRECTORY OF MAKERS—*Continued.*
**WARP BALLING MACHINES—**

Holt, Thos., Ltd., Atlas Works, Rochdale.

**WARP BEAMING MACHINES—**

Hattersley, Geo., &amp; Sons, Ltd., Keighley.

Holt, Thos., Ltd., Atlas Works, Rochdale.

Howard &amp; Bullough, Ltd., Globe Works, Accrington.

Keighley, Geo., Ltd., Burnley.

Knowles &amp; Co., Bradford.

Livesey, Hy., Ltd., Blackburn.

Platt Bros. &amp; Co., Ltd., Hartford Works, Oldham.

Smith, Wm., &amp; Bros., Ltd., Heywood.

**WATER SOFTENING (Installations)—**

Mather &amp; Platt, Ltd., Salford Ironworks, Manchester.

Royles, Ltd., Irlam, Nr. Manchester.

**WEIGHING MACHINES—**

Nesbitt, John, 42, Market Street, Manchester.

**WILLOWS (Oldham)—**

Greenhalgh, J., &amp; Sons, Ltd., Oldham.

**WINDING MACHINES (Self-Contained)—**

Brooks &amp; Doxey, Ltd. ("Morse"), Union Ironworks, M/c.

International Winding Co. ("Leeson"), Saville Street, M/c.

**WINDING MACHINES (Upright Spindle, Etc.)—**

Broadbent, Robert, &amp; Son Ltd., Stalybridge.

Brooks &amp; Doxey, Ltd., Union Ironworks, Manchester.

Dobson &amp; Barlow, Ltd., Kay Street Works, Bolton.

Hattersley, Geo., &amp; Sons, Ltd., Keighley.

Holt, Thos., Ltd., Atlas Works, Rochdale.

Howard &amp; Bullough, Ltd., Globe Works, Accrington.

Keighley, Geo., Ltd., Burnley.

Lees, Asa, &amp; Co., Ltd., Oldham.

Livesey, Hy., Ltd., Blackburn.

Platt Bros. &amp; Co., Ltd., Hartford Works, Oldham.

Smith, Wm., &amp; Bros., Ltd., Heywood.

Stubbs, Joseph, Manchester.

**WINDING MACHINES (Doubling)—**

Arundel &amp; Co., Stockport.

Broadbent, R., &amp; Sons, Ltd., Stalybridge.

Hattersley, Geo., &amp; Sons, Ltd., Keighley.

International Winding Co., Saville Street, Manchester

Larmuth, T., &amp; Co., Ltd., Salford.

Lees, Asa, &amp; Co., Ltd., Oldham.

Stubbs, Joseph, Manchester.

**WIRE WEAVING MACHINES—**

Hattersley, Geo., &amp; Sons, Ltd., Keighley.

**WRAP REELS—**

Nesbitt, John, Market Street, Manchester.

**YARN CLEARING FRAMES—**

Arundel &amp; Co., Sovereign Works, Stockport.

Stubbs, Joseph, Mill Street Works, Manchester.

**YARN TESTING APPARATUS—**

Cook &amp; Co., 18, Exchange Street, Manchester.

Nesbitt, John, 42, Market Street, Manchester.

Thomas, Geo., &amp; Co., Parsonage Lane, Manchester.

# LORD BROTHERS, L<sup>TD.</sup>

## TODMORDEN.

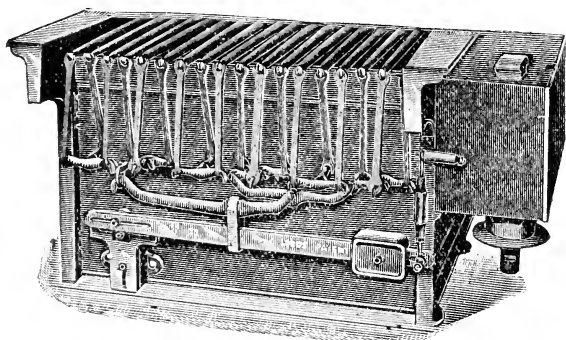

Lord's Patent "Tripod" Regulator.

**MAKERS OF**

**OPENING, CLEANING,**

**CARDING, SPINNING,**

**AND**

**WEAVING MACHINERY**

**FOR COTTON AND WASTE.**

Telephone No. 6.

Tel. Address: "Lords, Todmorden."

Manchester Exchange, Tuesday and Friday, No. 12 Pillar.

INDEX TO ADVERTISERS.

	PAGE
Abbatt, Wm., & Co., Bolton.....	xcvii.
Arundel & Co., Stockport .....	xxxvi.
Baldwin & Heap, Ltd., Burnley .....	xxx.
Bennett, J. J., Manchester .....	ci.
Bentley & Jackson, Ltd., Bury.....	lxxvii.
Blakey, John H., Radcliffe .....	ciii.
Bodden, Wm., & Son, Ltd., Oldham .....	lxxxix.
Bridge, David & Co., Ltd., Castleton.....	xxxii.
British Humidifier Co., Ltd., Blackburn.....	lxxviii.
Broadbent, Robt., & Son, Ltd., Stalybridge.....	lxvii.
Brooks & Doxey, Ltd., Manchester.....	xcii.
Brushes, Ltd., Oldham and Ashton-under-Lyne.....	xciv.
Clay Cross Co., near Chesterfield .....	cv.
Chadwick, Cobden, Oldham .....	xcv.
Cockill, Henry F., & Sons, Ltd., Cleckheaton .....	vi.
Cook & Co., Manchester .....	lxv.
Cook, Saml., & Co., Bury .....	ciii.
Cook, W. H., Manchester .....	xcv.
Cort, Joseph, Ltd., Blackburn .....	xci.
Coulthard, T., & Co., Ltd., Preston.....	xlviii.
Croft & Perkins, Ltd., Bradford .....	xii, xiii.
Dobson & Barlow, Ltd., Bolton.....	iv, xvi, lvi.
Dixon, John, & Sons, Steeton .....	xxvi.
Emmott & Co., Stalybridge .....	xcv.
Fairburn, J., Burnley.....	lxxxiii.
Fielden & Co., Rochdale.....	xcv.
Greenhalgh, John, & Sons, Ltd., Oldham.....	xcvi.
Greenwood & Batley, Ltd., Leeds.....	lxiv.
Gum Tragasol Supply Co., Ltd., Hooton .....	viii.
Hattersley, George, & Sons, Ltd., Keighley.....	lxvi.
Henshall, Wm., & Sons, Oldham .....	ci.
Hetherington, John, & Sons, Ltd., Manchester.....	xliv.
Holgate, Wm., & Sons (Oldham), Ltd., Oldham.....	lxxxii.
Holt & Kirk, Ltd., Oldham .....	cii.
Holt, Thos., Ltd., Rochdale.....	xxxiv.
Howard & Bullough, Ltd., Accrington .....	vii.
International Winding Co., Manchester .....	liv.
Jagger, E., & Co., Oldham.....	xxii.
Jones Bros., Ltd., Blackburn .....	xcvii.
Keighley, George, Ltd., Burnley .....	lxxx.
Keith, Jas., & Blackman Co., Ltd., London.....	xliii.
Kenyon, James, & Son, Ltd., Bury.....	lxxxvii.
Kenyon, Wm., & Sons, Ltd., Dukinfield.....	lxxxii.
Knowles & Co., Bradford.....	xciii.
Larmuth, Thos., & Co., Ltd., Salford.....	lxxv.
Lees, Asa, & Co., Ltd., Oldham .....	ix.
Livesey, Henry, Ltd., Blackburn .....	lxxvi.
Longworth, W., & Sons, Ltd., Bolton .....	xcvii.
Lord Bros., Ltd., Todmorden .....	xxxviii.
Lupton Bros., Ltd., Accrington.....	lxxxiv.
McMurdo, James, Manchester.....	lxxvii.
Mather & Platt, Ltd., Manchester.....	cvii.

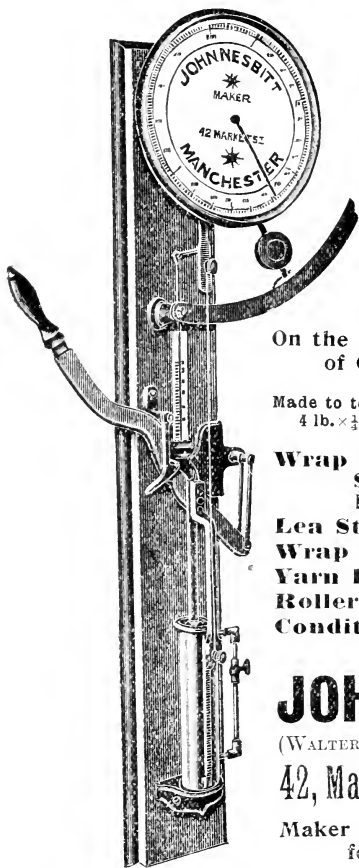

Improved Automatic  
Oil Plunge

# Single Thread Tester

On the DEAD WEIGHT Principle  
of Guaranteed Accuracy.

Made to test 1 lb.  $\times$  1 dram, 2 lb.  $\times$  2 drams,  
4 lb.  $\times$   $\frac{1}{3}$  oz., 10 lb.  $\times$   $\frac{1}{2}$  oz., and upwards.

**Wrap Reels. Sensitive Yarn  
Scales and Cardroom  
Balances.**

**Lea Strength Testers.**

**Wrap Blocks. Quadrants.**

**Yarn Examining Machines.**

**Roller Covering Machinery.**

**Conditioning Ovens.**

—\*—  
**JOHN NESBITT**

(WALTER S. NESBITT, ARTHUR H. NESBITT)

42, Market Street, Manchester

Maker of TESTING MACHINERY  
for all Textile Trades.

Telephone No. 2284.

Established 1784.

Contractors to Home and Foreign Governments.

Complete Catalogue Post Free on Application.



INDEX TO ADVERTISERS—*Continued.*

	PAGE
Matthews, Wm. A. & Co., Manchester.....	lxxxv.
Moscrop, Thos., & Co., Ltd., Bolton.....	lxxxii.
Moss, Wm., & Sons, Stockport.....	xv.
Musgrave, John, & Sons, Ltd., Bolton.....	x., xi.
Nesbitt, John, Manchester.....	xl.
Newton, Chambers, & Co., Ltd., London.....	ci.
Noton, S., & Sons, Oldham.....	ciii.
Noton, T., Oldham.....	ci.
Orme, George, & Co., Oldham.....	lxxii.
Philipson & Co., Bolton.....	lxxix.
Pilkingtón, Peter, Ltd., Bamber Bridge.....	xxviii.
Platt Bros. & Co., Ltd., Oldham.....	ii., iii.
Pollit & Wigzell, Ltd., Sowerby Bridge.....	lxix.
Porritt, Bror., & Austin, Ltd., Ramsbottom.....	xcix.
Reddaway, F., & Co., Ltd., Pendleton.....	lvii.
Roberts, John, & Co., Stockport.....	xvii.
Robinson, B., & Co., Bolton.....	ciii.
Royles, Ltd., Irlam.....	xxiv.
Saxon, George, Ltd., Manchester.....	xlii.
Schaellibaum, Rob., Co., Ltd., Manchester.....	cii.
Schirp, H., Barmen.....	xc.
Schofield, Wm., Oldham.....	c.
Scott & Hodgson, Ltd., Guide Bridge.....	lxx.
Smethurst, The H., Ventilating & Engineering Co., Ltd., Hollinwood.....	lxxxviii.
Smith, Wm., & Bros., Ltd., Heywood.....	xvii.
Stott, J., & Co., Oldham.....	lxii., lxiii.
Stubbs, Joseph, Manchester.....	lxxi.
Sutcliffe & Sutcliffe, Manchester.....	xc.
Swales, John, & Sons, Ltd., Oldham.....	lxxiv.
Tasker & Crossley, Halifax.....	xcvi.
Tatham, Wm., & Co., Rochdale.....	cvi.
Tattersall & Holdsworth, Enschede.....	lx., lxi.
Taylor, Lang, & Co., Ltd., Stalybridge.....	l.
Thomas, Geo., & Co., Manchester.....	lxxxiii.
Thompson, George, & Sons, Sowerby Bridge.....	xcviii.
Tomlinsons (Rochdale), Ltd., Rochdale.....	lii.
Tweedales & Smalley, Ltd., Castleton.....	lviii.
Tytler & Bowker, Manchester.....	lxxxvi.
Unbreakable Pulley Co., Ltd., Manchester.....	v.
United Alkali Co., Ltd., Liverpool.....	xcvii.
United States Metallic Packing Co., Ltd., Bradford.....	lxxiii.
Wainwright, Thos., & Sons, Ltd., Stalyridge.....	ci.
Walmsley, James, & Sons, Accrington.....	xvi.
Walrus Fibre Manufacturing Co., Ltd., Mirfield.....	xx.
Ward Bros. (Blackburn), Ltd., Blackburn.....	viii.
Wareing, Thos., & Co., Rochdale.....	ciii.
Whiteley, Wm., & Sons, Ltd., Lockwood.....	lix.
Wilson & Co., Barnsley, Ltd., Barnsley.....	xviii.
Wilson Bros. Bobbin Co., Ltd., Garston.....	xiv., xv.
Wray, G. & A., Keighley.....	lxxxvii.

---

# **GEORGE SAXON, Ltd.**

## **ENGINEERS AND MILLWRIGHTS,**

### **Openshaw, Manchester.**

Tel. No. 8100, 3 Lines.    Telegrams: "Saxons, Openshaw."

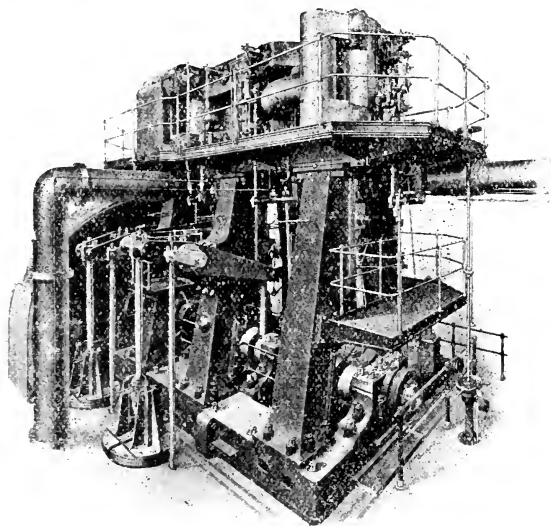

**HIGH-CLASS STEAM ENGINES,**

From 100 to 4,000 I.H.P.,

As supplied to the Lancashire Cotton Mills.

**MILL-GEARING OF EVERY DESCRIPTION.**

---

Special facilities for quick Repairs and Alterations.

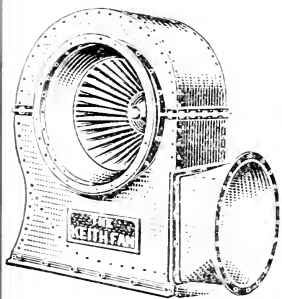

**THE "KEITH"**  
**AND**  
**"BLACKMAN"**  
**FANS**  
**FOR ALL PURPOSES**

**The "KEITH" LIGHT**  
**Ideal for Factory & Mill Lighting**

**JAMES KEITH & BLACKMAN CO.**

Engineers and Manufacturers,

LTD.

**27, Farringdon Avenue, LONDON,**  
E.C.

Manchester Office: 4, CANNON STREET.

And at Glasgow, Leeds, Birmingham, & Belfast.

Telephone No. **8065** (5 Lines).

Telegraphic Address: "HETH, MANCHESTER."

# JOHN HETHERINGTON & SONS, Limited

Also Proprietors of **CURTIS, SONS & CO.,**  
**PHŒNIX WORKS, MANCHESTER.**

Makers of all kinds of  
**Cotton Opening,**  
**Scutching, Carding**  
**Preparing,**  
**Spinning, and**  
**Doubling**  
**Machinery.**

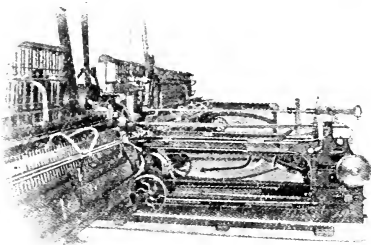
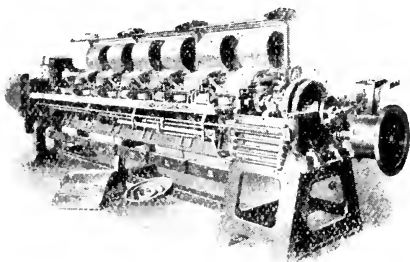

**CARDING AND**  
**SPINNING**  
**MACHINERY** for  
Waste and Wadding  
also Woollen and  
Worsted Yarns, also  
**ENGINEERS'**  
**TOOLS,**  
**MILL GEARING,**  
**HOISTS, &c.**

**SOLE**  
**MAKERS OF** **NASMITH COMBERS**

(See Page 94),

For Egyptian and American Cottons, also used for the  
**RECOVERY OF COTTON FROM WASTE.**

**ALL METAL CARRIAGE** for S.A. Mules.

**Josephy's Patent Cards and Condensers** for  
**Asbestos, Cotton Waste, Woollen, &c.**

**Pollard Street, Ancoats, Manchester.**

"Textile Mercury" Annuals

THE  
COTTON YEAR BOOK  
AND DIARY

1910

(Formerly "The Textile Year Book—Cotton")

—  
FIFTH YEAR OF ISSUE  
—

COMPILED (FOR "THE TEXTILE MERCURY")

BY

S. ECROYD

*Member of The Manchester Association of Engineers*

—  
PRICE 2/6 NET  
—

PRINTED AND PUBLISHED BY MARSDEN AND CO., LTD.,  
AT THE OFFICES OF "THE TEXTILE MERCURY,"  
CARR STREET, MANCHESTER.

COPYRIGHT

# DOBSON & BARLOW LTD.

BOLTON.

ESTD

1790.

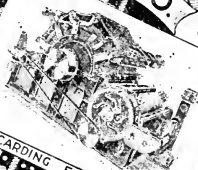
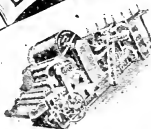

SCUTCHER

CARDING ENGINE

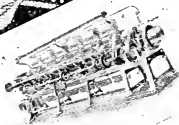
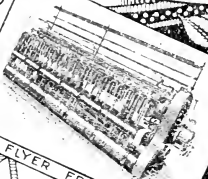
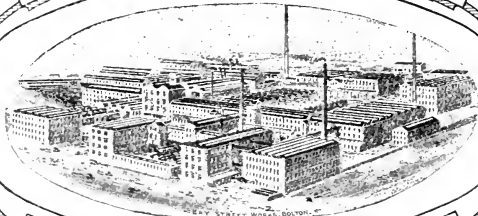

FLYER FRAME

COMBER

**MAKERS OF**  
Machinery for Cotton, Wool, Worsted,  
Silk & Waste Yarns & of many other  
Machines, Tools, Spindles, Fliers,  
Rollers, etc. etc.

## CONTENTS

(For detailed **Index** see p. 391.)

	PAGE.
<b>SECTION I. (The Raw Material)—</b>	
Leading Growths of Cotton .....	
Liverpool Cotton Market .....	
International Statistics .....	
<b>SECTION II. (Ring and Mule Spinning, Summaries of Machines, Drafts, Productions, etc.)—</b>	
Ring Mill, Arrangements, etc. ....	35
Mule Mill, ditto .....	44
Hank Rovings and Drafts .....	55
<b>SECTION III. (Opening, Scutching, Carding, Combing, Drawing, Spinning, etc.)—</b>	
Ginning, Opening, and Scutching .....	64
Carding .....	77
Combing .....	86
Drawing .....	96
Wrap Tables .....	107
Ring Spinning .....	111
Mule Spinning .....	119
Drafting .....	128
Roller Covering .....	132
Testing of Spinning, etc., Machines .....	140
Testing Cotton and Yarn .....	145
<b>SECTION IV. (Doubling, Doubling-Winding, Gassing, Reeling, Bundling, etc., Doubled Yarns)—</b>	
Doubling .....	161
Doubling-Winding .....	166
Gassing .....	169
Reeling .....	171
Preparing Grey Yarns .....	173
Bundling .....	174
Thread, Lace, Hosiery, and Nepped Yarns .....	176
<b>SECTION V. (Cotton Waste, Wadding, and Banding)—</b>	
Cotton Waste .....	187
Wadding .....	194
Banding for Spindles .....	197
<b>SECTION VI. (Preparatory Weaving Machines, Sizing Methods, etc.)—</b>	
Summary of Machines in a Shed .....	201
Preparatory Weaving Processes and Machinery .....	202
Sizing .....	217
Sizing Machinery .....	226

**SPINDLES, RINGS,  
TRAVERSE MOTIONS,**

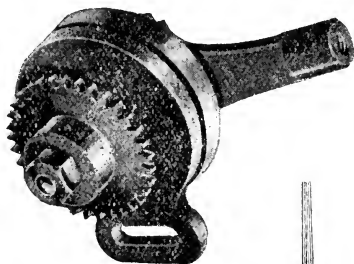

**LONG COLLARS,  
BOBBIN WHEELS,**

ETC., ETC.

**T. COULTHARD & CO.,**  
Ltd.,  
**PRESTON.**





## CONTENTS—Continued.

	PAGE.
Taper's Guide .....	234
Weaving .....	200
Principal Weaves and Fabrics .....	214
Warehouse and Office Work .....	221
SECTION VII. (Weaving, Plain and Jacquard Looms, Principal Weaves, etc.)—	
The Power Loom .....	240
Jacquards, Plaiting Machines, Presses .....	252
Standard Weaves .....	257
SECTION VIII. (Bleaching, Mercerising, Dyeing, Finish- ing, etc.)—	
Bleaching .....	267
Mercerising .....	275
Dyeing .....	283
Finishing .....	294
SECTION IX. (Warehouse and Office, Costing of Yarns and Cloth, etc.)—	
Grey Cloth Analysis .....	303
Costing of Cloth .....	305
Faulty Cloth .....	311
Invoicing .....	313
Patents for Spinning and Weaving .....	317
SECTION X. (Ventilation, Motive Power, Engines, Driv- ing, etc.)—	
Ventilation and Humidifying .....	326
Sprinklers .....	329
Lighting by Gas .....	330
Water Power .....	332
Gas Power .....	338
Boilers, Engines, Shafting .....	340
Rope and Belt Driving .....	358
Electrical Driving .....	363
Fencing of Machinery, etc. ....	370
SECTION XI. (Associations and Societies)—	
Employers' and Managers' Associations .....	376
"Mutual" Cotton Classes .....	378
Textile Associations Abroad .....	378
Operative Cotton Spinners' Amalgamated Associa- tion: Districts and Secretaries .....	380
Card and Blowing Room Operatives' Association: Districts and Secretaries.....	383
Local Associations (Operatives) .....	383
HOLIDAYS IN COTTON DISTRICTS .....	386
INDEX .....	391
DIARY for 1910, etc. ....	<i>following Index</i>

# TAYLOR, LANG & CO., Ltd.

Castle Iron Works, STALYBRIDGE.

Telegraphic Address: "Lang, Stalybridge."

Telephone No. 107.

Manchester Exchange, "P" Pillar, Tuesdays and Fridays.

MAKERS OF

**MACHINERY for PREPARING & SPINNING COTTON**

**also for SPINNING WOOL & WASTE YARNS.**

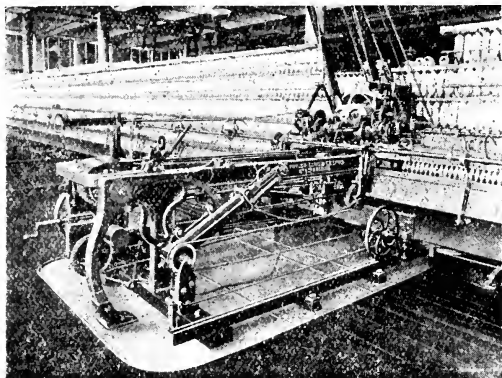

**Self-Acting Mule for Fine Counts.**

Hopper Bale Opener and Cotton Mixer.

Conveying and Distributing Lattice Work.

Exhaust Fans for Transit of Cotton.

Hopper Feeder with Patent Feed Supply Apparatus.

Buckley's Patent Combined Opener with One Cylinder and One Beater.

Buckley's Patent Combined Opener with Two Cylinders and One Beater.

Buckley's Patent Opener specially arranged for Sea Island Cotton.

Crighton Opener.

Roving Waste Opener.

Scutcher or Lap Machine (Single or Double).

Self-acting Mules for Coarse, Medium, or Fine Counts.

Patent Self-acting Mules, with One, Two, or Three Spindle Speeds for Spinning Waste, Barchant, or Woollen Yarns.

Self-acting Twiners.

## PREFACE TO FIFTH EDITION

---

In this, the fifth edition of "THE COTTON YEAR BOOK," an endeavour has again been made to deal yet more fully with the practice, processes, and mechanical plant of the cotton trade and industry. The volume contains nearly one hundred pages of fresh literary matter, and the remainder has been thoroughly revised; while some pages (*e.g.*, those devoted to a description of the cotton Futures Market) have been cancelled, so as to prevent the work becoming unwieldy. In the Raw Materials Section (I.) the space thus gained allows of a more detailed exposition of Spot Market procedure.

Sections II. and III. have been extended and thoroughly revised. That portion of Section III. dealing with Yarn Testing, etc., has been entirely rewritten, and now embodies particulars of the latest appliances used in connection therewith. The safeguarding of operatives against accidents has not been overlooked; and in this section will be found information thereon, as also on the removal of dust from carding engines during the stripping and grinding operations. On pp. 107-110 are given Wrapping Tables for the cardroom; and farther on are descriptions of modern appliances now being adopted in well-equipped spinning mills.

In Section IV., a similar course has been followed, especially with regard to Doubling-Winding and the Preparation and Gassing of Yarn. The table giving the ticket numbers for thread has been extended; and on p. 182 appears a table giving the average breaking strengths of 6-cord yarn for sewing thread.

Section V. (treatment of Cotton Waste) has again been revised, and includes descriptions of preparatory machines to facilitate the carrying-on of this process. The description of wadding manufacturing now includes observations on the preparation of surgical lint.

In response to suggestions received from readers, Sections VI. and VII. have been re-cast. Section VI is now devoted exclusively to Preparatory Machines for Weaving, which claim some forty pages. In these pages are given the various sequences of machines employed in Preparing Yarns for Grey and Coloured goods, with comments thereon from a practical point of view, references being made to all the recognised systems of Winding; and similar attention has been given to Warping and Sizing. The tables giving the wheels for marking cuts on the slasher sizing machine have been extended, and additions have been made to the portion devoted to the treatment of yarn in the hank.

# TOMLINSONS (ROCHDALE) LTD.

## MAKERS OF

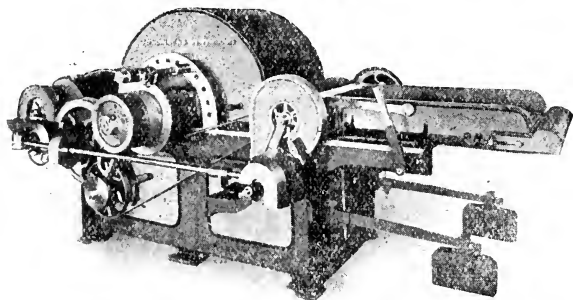

## ROYING WASTE OPENERS.

ALSO

CLOTH RAISING OR NAPPING MACHINES.  
HANK DRYING MACHINES.

ROTARY CLOTH PRESSES.

TEARING OR GRINDING MACHINES for  
Shoddy and Mungo.

RAW and DYED COTTON DRYING MACHINES.  
HARD WASTE MACHINERY.

ASBESTOS MACHINERY.

COTTON WADDING MACHINERY, etc., etc.

## SOHO WORKS, ROCHDALE.

Telephone No. 54 (Rochdale) and 5694 (Manchester).

Telegrams: "TOMLINSON, ROCHDALE."

Manchester Exchange, No. 12, Tuesday and Friday, 2 to 3.

Office, Exchange Buildings, St. Mary's Gate.

**PREFACE**—*Continued.*

Weaving proper takes up nearly the whole of Section VII., which is completed by descriptions of the jacquard and its accessory machines, and of the usual plaiting and pressing plant. Pp. 256-264 are devoted to the Standard Weaves of cloth, and diagrams are given illustrative of the various designs.

Section VII (Bleaching, Mercerising, Dyeing, etc.) has been revised and augmented. In this section the recent progress in colour work is concisely set forth; and on p. 292 will be found some practical observations on the variations in the weight of yarn resulting from bleaching and dyeing.

To the Warehouse and Office a separate Section (IX.) is now allotted. Therein will be found particulars regarding the Analysis and the "Costing" of Cloth; remarks on the causes of defects; and the methods customarily observed in the making out of invoices; information on (British) Railway Rates on textiles, etc., etc. The list of British patents granted during last year has been extended to include those relating to weaving as well as to spinning and doubling.

Section X. consists of memoranda on Ventilation and Humidification, Motive Power, Engines, etc. To these usual features have been added four diagrams illustrating the structure of mill foundations and roofs.

Section XI. gives the usual lists of Cotton Associations (employers' and operatives') at home and abroad, with a list of the Lancashire cotton districts holidays. There follows the detailed Index, which has been further elaborated—a remark that applies also to the "Directory of Machinery, etc., Makers," which will be found in the front portion of the volume (pp. XIX. to XXXVII).

Owing to the makers of some of the machines adopting special systems of gearing, it is impossible to give in every case the exact particulars as to speeds, etc. In such exceptional cases suitable allowance must be made for the variations from the usual standard.

In spite of every care, it is not unlikely that some errors have crept into the text. If readers who detect the same will draw the attention of the publishers thereto, their kindness will be much appreciated, and the necessary corrections will be made in next year's edition.

S. E.

"Textile Mercury" Office,  
Carr Street, Manchester,  
December 22nd, 1909.

# INTERNATIONAL WINDING CO.

Saville Street, Oxford Road, MANCHESTER.

MAKERS OF THE

## LEESON-WARDWELL UNIVERSAL WINDING MACHINES

For Winding Conical or Parallel Packages.

CONE WINDING  
for the  
HOSIERY TRADE.

CHEESE WINDING.

MULTI LE WINDING  
for the  
ELECTRIC TRADE,  
and for  
DOUBLING Purposes.

WINDING  
for  
BRAIDING.

WINDING  
for  
WARPING.

WINDING  
for  
SMALLWARE  
WEAVING  
and the  
LACE CURTAIN  
TRADE.

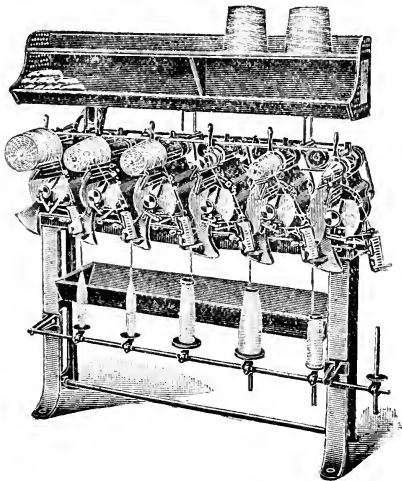

No. 50.  
CONE OR PARALLEL WINDING MACHINE  
Floor Space 4ft. 8in. by 1ft. 8in.

Our "NUTAPER" CONE gives the freest delivery of any Cone in the Market, and is specially recommended for the Hosiery Trade.

SECTION I:

RAW COTTONS

THE LIVERPOOL MARKET

---

WORLD'S

SPINDLES AND CONSUMPTION

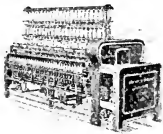

RING SPINNING FRAME

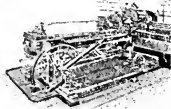

SPINNING MULE

# DOBSON & BARLOW, LTD BOLTON.

Telegraphic Address  
"DOBSONS, BOLTON"  
Codes used ABC & LIEBER

National Telephone  
No 601.

## MAKERS OF THE FOLLOWING

ROLLER AND SAW GINS.  
HOPPER BALE BREAKERS and  
MIXING LATTICES.  
HOPPER FEEDERS  
VERTICAL AND HORIZONTAL  
OPENERS  
SCUTCHERS  
CARDING ENGINES  
IMPROVED GRINDING  
MACHINES  
IMPROVED GRINDING  
ROLLERS.  
STRIPPING OR BURNISHING  
BRUSHES.  
SLIVER LAP MACHINES  
DERBY DOUBLERS  
DRAW AND LAP  
MACHINES COMBINED

COMBING MACHINES  
DRAWING FRAMLS  
FLY FRAMIS  
SELF-ACTING MULES  
SELF-ACTING TWINERS.  
SELF-ACTING BILLEYS  
RING OR FLIER THROSTLE  
FRAMLS.  
RING OR FLIER DOUBLING  
FRAMLS  
REELS  
WINDING FRAME WITH OR  
WITHOUT QUICK  
TRAVERSE MOTION  
GASSING FRAMES do do  
BANDING MACHINES  
BUNDLING PRESSES.

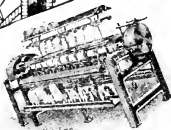

QUICK TRAVERSE WINDER

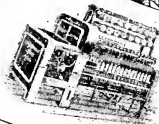

RING DOUBLING FRAME

ESTD  
1790



## THE LEADING GROWTHS OF COTTON

---

Those that have to purchase the raw material of the cotton manufacture, to arrange the "mixings," or in any other capacity have much to do with the raw material, should know as much as possible of its characteristics; for ignorance in regard thereto may cause much trouble and no little loss to those who have to spin the cotton.

Each crop differs from the previous one to a greater or lesser degree, as it depends entirely upon the weather, which in the cotton-growing areas of the world, as elsewhere, is variable.

Thus in a very dry season there is what is termed a "droughty crop," which, whilst it may be (and mostly is) clean and well up in class, will yet be poor in staple; and in order to obtain the desired length and strength of staple, the buyer will have to pay a relatively higher price than in what may be termed a normal season.

Again, in a crop that is poor in class—a defect that may have been caused by too much rain in the early or middle stages of its growth, or by unfavourable weather for the production of cotton of good grade—the staple will probably be all that could be desired, but the buyer will have to pay more to obtain his usual grade, and especially so if he requires it for good weft.

Then there are seasons when the crop turns out fairly good in class and staple, but the cotton is wasty, dirty, or abnormally leafy; and in this case the buyer has to exercise great care and judgment in calculating the extra loss that will ensue.

The above remarks refer particularly to American cotton, but they are applicable to other growths.

The reader may be considerably helped by studying the following concise statement of leading facts relating to Cotton Cultivation in the principal varieties:—

### **The American Crop.**

The first step taken is the preparation of the ground for planting. This begins in the southern part of Texas as early as the middle of January; in Florida about the third week; in Alabama, Georgia, Mississippi, and Louisiana, about the beginning of February; in Arkan-

sas, Tennessee, and South Carolina from about the middle of February to the beginning of March. Actual planting begins (according to latitude) principally from the middle of March to the middle of April, and ends in the first half of May. These dates, however, are dependent upon the state of the weather. When the weather is unusually wet the start is late, the plant suffers from the rank growth of grass and weeds, and extra labour is required to keep the fields clean. In abnormally hot weather, especially after rains, the plant sheds its leaves, thus exposing the bolls, which fall off, whereupon replanting becomes necessary. In addition to injuries by weather, the cotton plant is subject to depredations by insects. Of late years the greatest pest has been the Mexican boll-weevil.

When the crop is an early one, picking may commence in the districts in which it ripens first, in the latter half of July; but the usual date is the beginning of August, following on in the various districts in succession until the early part of September. The plant goes on fruiting as long as the weather is mild and open. It finishes in the early regions about the beginning of December, the others following through December, and closing in the later regions about the middle of January.

Frosts play an important part in the ultimate yield. An early killing frost over the entire belt would curtail the size of the crop by 500,000 bales, in a season such as the last, when about 32,000,000 acres were planted, and there have been normal conditions. Light frosts and late frosts do little harm to the cotton plant; in fact it is contended that late frosts do much good under certain conditions of the crop, by opening bolls that otherwise would not open, and thus adding to the quantity of late pickings.

The effect of frost upon the lint so picked is to produce tinged and stained cotton. Early killing frosts occur in some seasons in the early part of November, when much of the yield may be curtailed. When killing frost occurs late in the season, when the fruiting is practically over, it has little or no effect upon the yield except as regards the colour. In Shepperson's "Cotton Facts" there are given the dates of the principal killing frosts that have been recorded.

Cotton grown over the wide area of the Southern States of the American Union—under widely varying

conditions of soil, climate, and care in cultivation—naturally varies in its length, strength, and other qualities of staple.

Cotton known as "Uplands" or "Bowed" varies in length from  $\frac{3}{4}$  to  $1\frac{1}{16}$  inch, and is used for *welt*; this is grown in North and South Carolina, Georgia, Florida, Alabama, and Tennessee. Cotton used for *twist* is grown in Texas, Louisiana, Mississippi, and Arkansas, and the length of the staple varies from 1 to  $1\frac{3}{16}$  inch.

In the swampy and bottom lands in some of the above-named States (notably Alabama, Louisiana, Mississippi, and Arkansas), cotton is grown with staple ranging from  $1\frac{1}{8}$  inch to  $1\frac{1}{4}$  inch.

In addition to these, there are specially long-stapled growths known as "Extras," "Allen Seed," and "Peelers," which measure  $1\frac{3}{8}$  to  $1\frac{5}{8}$  inch. Of late there has been an extensive demand for long-stapled American ( $1\frac{3}{16}$  to  $1\frac{1}{2}$  inch) owing to the development of fine spinning, and much higher prices have been obtained, in proportion to *Middling* American, than ever before—as much, indeed, as 6d. to 7d. per lb. over the basis of Future Contracts having been paid.

#### **Brazilian and Smooth Peruvian.**

Cotton of these growths is in a measure a substitute for American, especially for *twist*, but the quantity grown and exported to this country is insignificant, as compared with American.

#### **Rough Peruvian.**

The nature of this cotton resembles wool so nearly that it is almost exclusively used to mix therewith. The staple is rough and generally strong, and is of a springy tendency: *i. e.*, it does not lie close like American.

#### **East Indian.**

Unlike the foregoing countries, India depends upon the monsoon for its moisture, and the success or failure of the crop is decided by that phenomenon of nature.

The land is prepared before, and the planting begins after, the breaking of the monsoon. Picking generally begins in Bengal in October, followed by Oomrawuttee, Broach, Dhollerah, and Comptah, which extends to about the middle of March. Madras is the latest—about April.

There is not the same care bestowed upon the cultivation of Indian cotton, nor are such improved methods

practised, as rule in America. The ancient routine of past generations still persists, and as a consequence the yield per acre is less than one-half of that of America. Moreover, the acreage planted is only about two-thirds that of America.

The better growths of East Indian cotton were once largely used in this country for weft (either alone or mixed with Boweds), owing to their good colour and cleanliness; but of late years the consumption has steadily decreased—owing chiefly to the increased takings by the Indian mills; secondarily to the exports to China and Japan; and also to the preference shown by English spinners for American cotton, especially when the price of Machine Broach approximates to that of "Middling" Boweds.

#### **Egyptian Cotton.**

Egyptian does not depend upon the rainfall for the success of the crop, as do other growths, but upon the overflow of the Nile. Prior to the completion of the irrigation works in 1902 at Assouan and Assuit, the risk of failure was always great; since then, however, a sufficient supply of water has always been available. The rising of the Nile begins about July and culminates about October. The fertilising properties of the muddy deposit of the waters are very great, and this accounts for the exceedingly good staple that characterises this growth of cotton. It has been thought by some that since the building of the dams a percentage of the deposits have been prevented from reaching the land and thus fertilising it fully; but any disadvantages on that score are immeasurably compensated for by the certainty of an abundant supply of water. The best qualities of Egyptian cotton are grown in Lower Egypt.

Egyptian cotton is largely used in the manufacture of hosiery, and also for mixing with worsted yarn. Owing to its gloss, it is used for mixing with silk, and on account of its strength it is made into the finer sewing threads.

In addition to cotton, other crops are grown in Egypt—rice, sugar, beans, barley, onions, etc., and the acreage devoted to cotton is regulated to some extent by the prospects as to which crops are likely to pay best. It is calculated that not more than one-third of the area is usually devoted to cotton.

**Sea Island Cotton.**

This is the finest growth of cotton, and it commands the highest price. The staple, which is very long and silky, varies in length from  $1\frac{1}{2}$  to  $2\frac{1}{2}$  inches. It is used for making very fine muslins and other fabrics, and is also largely mixed with silk.

It is said that this cotton was first introduced into America in 1786 from the Bahama Islands, where it had been brought from the West Indies. It was first cultivated in Georgia, when it was found that the small islands running along the coast were best adapted for its growth: hence the name "Sea Island." It was also grown on the uplands of Georgia, but although remaining good, the quality deteriorated.

**British Empire Cotton.**

The British Cotton-Growing Association (chairman, J. Arthur Hutton, Esq.), whose offices are at 15, Cross-street, Manchester, continues to demonstrate the fact that supplies of cotton in all grades and in large quantities can be grown within the boundaries of the British Empire. The accompanying table shows at a glance the progress made under the auspices of the Association. It is an approximate estimate of cotton grown more or less directly under the auspices of the British Cotton-Growing Association (given in Bales of 400 lb.) :—

**WEST AFRICA :—**

	1903.	1904.	1905.	1906.	1907.	1908.*	1909.
Gambia .....	50...	100...	300...	— ...	— ...	— ...	—
Sierra Leone...	50...	100...	200...	150...	100...	— ...	—
Gold Coast ....	50...	150...	200...	200...	250...	200...	300
Lagos .....	500...	2,000...	3,200...	6,000...	9,500...	5,500...	12,000
S. Nigeria .....	50...	100...	150...	150...	250...	200...	300
N. Nigeria.....	50...	100...	500...	1,000...	1,500...	500...	1,000
<b>EAST AFRICA :—</b>							
Uganda .....	— ...	150...	300...	500...	2,000...	5,000...	7,000
Brit. E. Africa	50...	100...	150...	200...	200...	300...	300
Nyasaland ....	100...	550...	1,500...	2,200...	2,300...	1,500...	2,500
Rhodesia .....	— ...	50...	50...	100...	200...	300...	500
West Indies .....	1,000...	2,000...	4,000...	5,500...	6,500...	7,000...	6,000
Scind .....	— ...	— ...	500...	1,000...	1,800...	2,000...	2,500
Sundries .....	— ...	100...	150...	200...	300...	500...	600
<b>Total .....</b>	<b>1,900...</b>	<b>5,500...</b>	<b>11,200...</b>	<b>17,200...</b>	<b>24,900...</b>	<b>23,000...</b>	<b>33,000</b>

Approximate value (in 000's).. £29... £75... £150... £260... £390... £360... £480

\* Drought in West Africa.

British West Indian cotton is excellent, and it competes successfully against that of the long-stapled growths of America. This growth dates a long way back: for, 135 years ago, the West Indian Colonies supplied Lancashire with 6,000 bags of cotton. It was grown before cotton was cultivated in the United States, but was superseded by tobacco, sugar, etc.

West African cotton is a substitute for the medium grades of American, and some is of very good staple. It is not so regular in colour, being inclined to be tinged. With careful cultivation, a sufficient supply of labour, and railway facilities to the coast, together with moderate freight therefrom—presuming also a fair price can be obtained—the quantity should greatly increase.

At the 70th meeting of the Council of the British Cotton-Growing Association, held on the 7th December, 1909, the following reports were presented:—

**West Africa.**—The purchases of cotton in Lagos to the end of November amount to 11,992 bales, as against 5,374 bales for the same period in 1908, and 8,373 bales for 1907. Up to date 11,700 bales have been ginned. It is probable that the crop estimate of 12,000 bales will be exceeded. The climatic conditions seem to have been favourable, and a good crop is expected in 1910.

In order to improve the quality of the cotton, steps are being taken for the inspection of seed cotton before it is purchased. This inspection will be carried out by the Government, and will come into force in May next, which is about the time when the quality of the cotton generally begins to fall off.

**Uganda.**—The prospects are most favourable, and the present high prices of cotton are giving a great stimulus to the industry. The hydraulic press which was sent out by the Association is being erected at Kisumu, on Lake Nyanza, and by this means a considerable saving will be effected in freight charges on the cotton. Arrangements have been concluded for a better service of steamers between this country and British East Africa. With regard to the quality of the cotton from Uganda, the great drawback has been the stained condition in which it is received, and the Uganda Government Agricultural Expert has recently visited Manchester and Liverpool to discuss with the Association the best means of overcoming this difficulty. Steps are being taken to improve the seed supply by selecting from the best varieties now being grown in the country.

**Nyasaland.**—The quality of the cotton has improved immensely. Several large shipments have recently been received from planters financed by the Association, and one of these consignments has been pronounced by a Liverpool expert as the best Upland American type of cotton yet produced. This consignment was sold at 10d. per lb. In addition to cotton produced by white planters, the native-grown crop has greatly exceeded that of any previous year.

### CLASSIFICATION OF GROWTHS OF COTTON.

**AMERICAN** is classed by grades, thus:—

(Ord.)	(G.O.)	(L.M.)
Ordinary.	Good Ordinary.	Low Middling.
(Mid.)	(G.M.)	(M.F.)
Middling.	Good Middling.	Middling Fair.

These are divided into half and quarter grades, thus:—

<i>Ordinary.</i>	<i>Low Mid.</i>
Strict Ord.	Strict L.M.
Fully Ord.	Fully L.M.
Barely Ord.	Barely Mid.
Good Ord.	Middling.

And so on through each grade.

**BRAZILIAN** is classified thus:—

Mid.	Mid.	Fair.	Fair.	Good	Fair.	Good.
			Fine.			

**EGYPTIAN** is classified thus:—

Middling.	Mid.	Fair.	Fair.	Good	Fair.
Fully	Good	Fair.	Good.	Fine.	Extra Fine.

**PERUVIAN** is classified thus:—

Ordinary.	Mid.	Mid.	Fair.	Fair.	Good	Fair.
	Good.	Fine.	Extra	Fine.		

**EAST INDIAN** is classified thus:—

Good	Fair.	Fully	Good	Fair.	Good.	Fully	Good.
		Fine.	Super	fine.			

**WEIGHTS of Various Growths:—**

American, about 500 lb. per bale.

East Indian (hard compressed), about 400 lb.

Egyptian (hard compressed), about 730 to 750 lb.

Brazilian and Peruvian vary in weight; the light packages run from 160 to 175 lb.; the heavy ones from 350 to 500 lb.





## THE LIVERPOOL COTTON MARKET

---

An historical sketch of the rise and development of the Liverpool Cotton Market appeared in the 1908 issue of this "Year-Book" (pp. 52-56). Therein it was traced how the ever-increasing business in "futures" gave rise to the necessity for its being regulated; and that the outcome was the establishment of the Clearing House, and afterwards of the Cotton Bank.

About 1882-83 an agitation took place in favour of periodical settlements for "future" contracts. After much opposition the principle was adopted, and ultimately the custom of weekly settlements became the rule, and this prevails at the present time.

The Futures Market makes possible the moving of cotton from the plantations to the mill without risk of loss from the fluctuations of the markets, and enables spinners and manufacturers to "cover" their sales of yarn and cloth.

There are also other ways by which spinners cover their sales of cloth. These are, by purchasing "cost, freight, and insurance"—termed c.i.f. and 6 per cent. terms; by purchasing for gradual delivery equal to a sample agreed upon, which is mostly sealed until the cotton is tendered; and by purchasing cotton already shipped, either on grade or actual American sample. In all these cases the price can be fixed at the time of purchase, or "on call" within a specified time. Still, whichever mode be adopted, the merchant who sells to the spinner has, with scarcely an exception, to "cover" in the Futures Market.

Not many years ago the business in "futures" was done on the "Flags"; but after many attempts to effect a change, and much opposition, this was transferred to the "Room." This "Room" was really commodious, and at the time the change was made the accommodation was thought to be ample. Nevertheless it was later found to be inadequate, and the magnitude of the cotton trade of Liverpool may be best gauged by its magnificent Cotton Exchange, recently erected in Old Hall Street. After providing for the wants of the Association, there are numerous offices and sale-rooms available in the Exchange to accommodate the merchants and brokers. There are at present about 600 members of the Liverpool Cotton Exchange. The change has conduced

to the convenience of those connected with the cotton business, and the facilities offered for conducting both the Spot and Futures departments in the cotton Exchange itself are such that the volume of business has room to and must expand.

### LIVERPOOL AS A SPOT AND FUTURES MARKET.

For over a century, in fact since Cotton Spinning was seriously established as a great commercial industry in the last quarter of the eighteenth century, Liverpool has played the important rôle of chief importing and distributing centre for all varieties of cotton. The following figures will give an idea of the progress made during the last hundred years:—

#### ANNUAL IMPORTS OF COTTON INTO LIVERPOOL.

Year	American	Brazil	East In.	Others	Total
1808 .....	38,000...	50,000...	13,000...	+67,000...	168,000 bales.
1908 .....	3,317,000...	22,000...	173,000...	*619,000...	4,131,000 ..

† No Egyptian. \* 477,000 bales Egyptian included.

#### CONSUMPTION IN LANCASHIRE (all sorts).

1808 :—210,000,000 lb.

1908 :—3,379,000,000 lb.

These enormous increases have been brought about by the geographical position of Liverpool as a port, its shipping facilities and ready means of transit, its proximity to the great spinning industry of Lancashire, and especially by the activities of the Liverpool Cotton Association, whose endeavours on behalf of the trade at large have been copied by all other Cotton Exchanges.

The advantages of the Liverpool Cotton Exchange are many, and offer to all, whether shipper, importer, buying broker, or spinner, equitable trading, under Rules and Regulations that provide for all parties, with penalties for any infringement of Rules by any member or members of the Liverpool Cotton Association, Limited.

The Liverpool Cotton Market is the largest Spot market in the world, no other centre approaching it in quantity of stocks or in the variety of growths offered for sale. Some idea may be gleaned from the following list of varieties of cotton offered in Liverpool for sale:—American, Egyptian, Brazilian, Peruvian, West Indian, Smyrna, East Indian, Chinese, African, Grecian, etc., etc.

The stock of all sorts of cotton in Liverpool on Friday, 26th November, 1909, was 1,114,000 bales. This may be compared with the stocks of the following Exchanges, on the same day, namely:—New York, 134,000 bales; New Orleans, 153,000 bales; Havre, 313,000 bales; Bremen, 182,000 bales; and Bombay, 136,000 bales.

Dealing with the Liverpool stock, let us now see how it is controlled, *American* being taken as offering the best illustration. During the latter part of July and early August (or a month before the official season commences on September 1st) the majority of merchants and importers in Liverpool send out their representatives to the United States, with instructions to buy certain styles of grades and staples on favourable terms, suitable for the requirements of the British spinning industry. (As year by year the better class of cotton goods are being manufactured more by the Home Trade, low grades of cotton are very little in demand.) In some cases, brokers in the Liverpool market send their offers direct to American buying houses that have centres in the larger interior towns. There are several minor methods employed in importing, but of a detailed character.

It is sufficient to deal with the cotton shipped from the other side *en route* for Liverpool. All cotton arriving in Liverpool becomes subject to the laws of the Liverpool Cotton Association. To quote the laws and bye-laws at length would occupy too much space, but a few of the most important may suffice to show how the interests of both buyer and seller are safeguarded. Take a shipment of "C.i.f." cotton: It is controlled by the following—

### COST, FREIGHT, AND INSURANCE CONTRACT FORM (AMERICAN COTTON).

PORT AND/OR CUSTODY BILL OF LADING.

(1st February, 1909.)

LIVERPOOL.....

Messrs.....

We have this day.....(on the terms of the Rules, Bye-Laws, and Clearing House Regulations of the Liverpool Cotton Association, Ltd., whether endorsed hereon or not).....Bales.....Cotton averaging, per 100 Bales gross, 50,000 lb. for all descriptions excepting Texas, Oklahoma, and Arkansas Cotton, which shall average 53,000 lb. for all descriptions excepting Texas, Oklahoma, and Arkansas Cotton, which shall average 53,000 lb. and

all other Gulf Cotton, including Alabama, which shall average 51,000 lb. per 100 bales gross (a variation of 5 per cent. allowed), Cost, Freight, and Insurance, for .....

(a) at ..... per lb.

or

(b) at.....points.....the Seller's price of..... delivery (Middling American, G.O.C.) in Liverpool at the time of call. The Cotton to be called in lots of not less than 100 bales on or before.....but not later than the declaration of marks and ships' names. Calls to be made on the Single month.

To be invoiced at American actual gross weight, less an allowance of six per cent.

(a) Gross landing weight guaranteed to be within one per cent. of gross invoice weight.

or

(b) Net weight (that is actual weight of bales, less Bands and 4 per cent. allowance for Canvas and Draft), guaranteed by Sellers equal to Net American invoice weight. Settlement to be made with mutual allowances as to weight.

To be shipped during..... per.....

from ..... to ..... via .....

Invoice with full particulars to be rendered to the buyer within four weeks of the date of Bill of Lading.

Marine Insurance shall be provided by the seller with including particular average and country damage, and covering 5 per cent. in excess of Invoice cost, or in the case of Cotton sold on "Call" 5 per cent. in excess of market value up to the "Call" price. Any amount over this shall be for sellers' account in case of total loss only. The cost of stamping documents to be borne by the seller.

After the date of the "Call" Marine Insurance on any increase in value over and above the "Call" price is at buyer's risk.

In case of any casualty occurring after declaration has been made (the Cotton not having been "Called" previously), the seller shall immediately notify the buyer, in writing, of the same, and the "Call" shall be made not later than noon of the first business day following such notification.

(1) Reimbursement by M.....Drafts upon M..... at.....days' sight for Invoice amount. The buyer guarantees the due protection of the Drafts on presentation and payment at maturity.

or

(2) The due date of Invoice shall be the 75th day after date of Bill of Lading, payable in Liverpool.

(a) Payments shall be made in exchange for Shipping Documents on, or (at buyer's option) before, arri-

val of the Vessel or Vessels; or, failing previous arrival, not later than due date, by cash, less customary rebate for any prepayment.

or

- (b) Payment shall be made in exchange for delivery of the Cotton as it may arrive (the buyer paying all Liverpool charges) by cash, less customary rebate for any payment made before due date, or plus interest at 5 per cent. per ann. for any payment made thereafter. If any Cotton declared against this Contract be lost in transit, the Contract for such Cotton shall be at an end, but the seller shall collect for the buyer the excess agreed to be insured over invoice amount. In event of damage, covered by Marine Insurance Policy, the seller shall collect the amount of same from the Underwriters, on buyer's account.

No allowance to seller. Should arbitration be demanded by the buyer the Cotton shall be subject to mutual allowances, except in the case of average shipment. Should any lot prove inferior to.....the buyer to have the option of accepting the Cotton, or of returning it to the seller under the provisions of Rule 12 as endorsed.

No Penalty.

Yours faithfully,

Contracts on very similar lines are also framed for Egyptian and East Indian cotton.

Next comes the ordinary Arrival Spot Contract, as under:—

### ARRIVAL CONTRACT.

(27th November, 1905.)

LIVERPOOL.....190

M.....

We have this day.....To Arrive in Liverpool, to be shipped during.....from.....bales Cotton on the basis of .....per lb. for.....on the terms of the Rules, Bye-laws and Clearing House Regulations of the Liverpool Cotton Association, Ltd., whether endorsed hereon or not.

The Cotton to be taken with mutual allowances, to be settled by arbitration, but any lot below.....

may be returned by the Buyer under Provisions of Rule 7

To be taken from .....

Each 100 bales to be treated as a separate Contract, if required.

Yours faithfully,

This Contract was made on the date specified, within the limits of the time fixed by the Liverpool Cotton Association, Limited.

The Contract for Deferred Delivery is as follows:—

AMERICAN COTTON.

CONTRACT FOR DEFERRED DELIVERY OF SPOT COTTON.

(October 1st, 1902.)

LIVERPOOL.....190

We have this day.....to/from you.....

.....Bales.....COTTON, ex.....

at .....per lb.

To be delivered as follows:—

Subject to the Articles, Bye-Laws and Rules of the Liverpool Cotton Association, Limited.

Payment in Cash within ten days from the date of Invoice, or before delivery, if required. Claims for falsely or fraudulently packed, damaged, or unmerchantable Cotton, will be allowed at the value of the sound Cotton, at the date of return, if such return is made and the Claim sent in within ten days and three months from the date of Invoice.

Any bales found to be not equal to the selling sample shall be exchanged once, at the option of the seller, or invoiced back, according to the provisions of Bye-Law 26.

In the event of loss or damage by, or in consequence of fire, before the Cotton shall have been weighed over to the buyer, the contract for any portion so lost or damaged shall be settled at the market value of the Cotton on the date of the fire. Interest at the rate of 5 per cent. per annum from the date of fire to the due date for completion of the contract shall be paid to the buyer on the estimated Invoice amount.

Yours faithfully,

### Arbitration.

Practically all contracts made on "Liverpool terms" are subject to arbitration; therefore a resumé of the duties of an arbitrator may be of interest.

Twenty-seven members of the Association are elected yearly to serve on the Arbitration Committee, and the seven receiving the largest number of votes constitute the Appeal Committee.

All arbitrations, either on Spot or Docket Cotton, are conducted by the Committee, the members of which attend the Arbitration Room of the Association at a fixed hour for Docket Cotton, or by appointment for Spot. The awards of the arbitrators are binding on buyer and seller, subject to the right of appeal to the Appeal Committee, whose decision is final.

Standard samples of cotton in duplicate (one set "Reserved" and the other "Working"), of various grades, are made up by the Appeal Committees of the various growths, and are kept in possession of the Secretary at the Association Rooms.

The Working standards are available in the settlement of Arbitrations and Appeals, and are open to the inspection of members. The Reserve sets are not altered without the express authority of the Association, and the Working and Reserve standards are compared monthly by the Appeal Committee. In the case of American cotton the standards are renewed once a year.

### The "Spot" Market.

The actual purchase or sale of Spot cotton is accomplished in the following manner (excepting where a spinner buys "on averages"): —

A spinner notifies his Liverpool broker that upon such and such a day he will be buying a certain style of cotton. The broker (through his salesman) informs the selling brokers' representatives, who are waiting in force in the Exchange each morning about 10 o'clock, of his requirements. Samples are then sent in to be submitted to the spinner, assisted by his broker. Perhaps 50 to 100 lots of different cotton, but all of the style required, will be presented for sale. A selection is made and the price bid to the seller, who, if he accepts, covers his sale by a purchase in the Futures Market, a subject dealt with elsewhere.

The cotton being bought, delivery is taken by the buying broker, who charges commission at the rate of  $\frac{1}{2}$  per cent. of the gross value of the cotton, plus cartage and portorage charges as under:—

For lots of 5 bales and under .....	1s. per bale.
.. .. 6 to 10 bales .....	9d. ..
.. .. over 10 bales, of bales weighing 350 lb. and upwards ...	6d. ..
.. .. over 10 bales, of bales weighing 250 to 350 lb. ....	4½d. ..
.. .. over 10 bales, of bales weighing under 250 lb. ....	4d. ..

It is understood that when cotton is offered for sale, unless the contrary be expressly stated, the bulk of the lot is ready for delivery. The buyer is entitled either to cancel the contract for any portion that cannot be delivered, or to claim that the average date on which the cotton was ready for delivery shall be the date of the invoice. Should any inferior bales turn up at the scale, they are placed aside for subsequent settlement, and the delivery of the remainder is proceeded with. Cotton must be taken by the buyer within ten days of the date of invoice, and payment must be made within ten days from the date of invoice, unless otherwise arranged. Interest at the rate of 5 per cent. per annum is allowed on money paid before the due date, and is charged at a like rate from that day to the day of payment.

In the case of buying "on averages" (mentioned above), the broker forwards small samples of cotton—called "averages"—to the spinner, who selects and makes a bid by telephone or telegraph. If accepted, the same conditions rule as in Spot purchases.

When the buying broker has taken delivery of the cotton from the selling broker, it is forwarded to the mill, where it is broken up. Should, however, any of the bales prove faulty (*i.e.*, reveal excess of tare, error in weight, damp or wet, or be falsely packed), then claims are made (all being provided for by the Bye-laws of the Liverpool Cotton Association) on the selling broker, who either accepts the responsibility or reclaims on the American shipper.

At 11 o'clock daily, the estimate of the daily sales of Spot Cotton, generally ranging from 7,000 to 12,000, is posted in the Room. In extreme cases, however, 20,000 or even 30,000 have been posted on the board. The re-



sponsibility for estimating the sales devolves upon an official of the Association, who between 10 and 11 o'clock makes inquiries among the selling and buying brokers as to the probable turnover for the day, and any sales made after 2-30 the previous day. At 11 o'clock the figures (say 10,000) are posted. They may include 7,000 for the current day and 3,000 sold late the previous day. If any sales are made between 11 o'clock and 2-30 p.m., the figures are increased accordingly. The sales are not increased after 2-30 o'clock. About 3 o'clock the sales are sub-divided as follows:—

Spot Sales 6,000. Called 3,000. Speculation and Export 1,000. Total 10,000 bales. Or: Spot Sales 4,000. Called 3,000. Spec. and Export 1,000. Sold late yesterday: Spot, nil. Called 2,000. Spec. and Export nil. Total 10,000.

Every Friday before 3 o'clock (except when holidays intervene) every firm is *compelled* to deliver to the Association a complete return of "Sales or Forwarded" under the headings provided, and a fine is imposed for late delivery of the form. The returns are tabulated, and published on Saturday mornings, with the comparison of the estimated sales.

**"On Call" Cotton.**—It will be noted that the terms "Spot," "Called," and "Spec. and Export" are used. "Spot" explains itself, but "CALLED" cotton (even to many in the trade) is surrounded with complications. It may be explained thus:—

(1) Contract made on 1st Sept. for 400 bales American cotton in the Port of Liverpool sold "on call," to be delivered 100 bales weekly in September. Prices fixed on following dates: 100 bales 6th Sept., 100 bales 12th Sept., 100 bales 20th Sept., 100 bales 25th Sept. Each 100 bales to be returned as "Sales" in the week in which the price is fixed.

(2) Contract made on 1st Sept. for 500 bales American cotton sold at 7.36d. for deferred delivery, 200 bales of which are in Port and 300 have not arrived. At the end of the first week in September 200 bales only are returned; 300 bales are not returned at all.

(3) Contract made on 1st Sept. for 1,000 bales American cotton sold "on call," to be delivered 500 bales in November and 500 in December (none of the cotton being in Liverpool at time of sale). The price for the 1,000 bales is fixed on 31st October, at which time 600 bales have arrived and are in Liverpool and 400 have not

arrived. The 600 bales are returned in the "Sales" on 31st October, and 400 bales never come into "Spot Sales."

(4) Cotton sold "on call" which has been forwarded before the price has been fixed is not returned as forwarded unless the price be fixed during the week in which the cotton is forwarded.

**"Spec. and Export."**—Cotton bought by one Liverpool house from another for resale on the market is called "Speculation," but if for export it is classed "Export." Transactions under these headings are returned by the respective buyers.

Twice yearly, at the end of August and of February, members are compelled to return all the stock they hold, and any differences between the estimates and actual figures existing on the same day are adjusted by the Liverpool Cotton Association, and form the basis of future statistics.

The prices of "Spot Cotton" are fixed daily at 12-30 p.m., by the Committees appointed for the various growths. As a rule the price of American Middling is altered to harmonise with the difference in Futures, between 12-15 p.m. each day, other growths being in sympathy with American, excepting Egyptian, in which the alteration of the prices is controlled by the fluctuations of its own Futures market.

There are a few side issues regarding the technicalities of Docket Cotton, but they have no real bearing on the customs or regulations of the Spot business. We have therefore now described the movement of a bale of cotton from the time of its importation to its arrival at the mill, when it passes beyond the province of the Cotton Association.

### The "Futures" Market.

Earlier in this article reference was made to the "Cover" with "Futures" of a sale or purchase of Spot Cotton. The "Futures" market is the "Insurance" Department of the Liverpool Cotton Association, governed by its stringent rules and bye-laws. Without its facilities the importing and reselling of actual cotton would be attended with grave risks, in fact, would be impossible from a merchanting point of view. For the working of the Futures Market we cannot do better than refer our readers to a manual—"Cotton Futures: What they Are, and How they Work in Practice"—by Mr. Charles Stewart, of 1, Cotton Exchange Buildings,

Liverpool. The text of this manual was printed in the edition of "The Cotton Year Book" for 1909, but is omitted from the present issue owing to lack of space.

---

## NET WEIGHT COTTON CONTRACT:

### Purchasing by Net Weight.

At the fifth Congress of the International Federation of Master Cotton Spinners' and Manufacturers' Associations, held in Paris in June, 1908, the following important resolution was passed:—

That this meeting, having heard the report of the Cotton Contract Commission, instructs such Commission to place before the European Cotton Exchanges the form of the c.i.f. contract on a net weight basis without franchise; and as soon as such form is accepted by the Exchanges, strongly advises the trade to use the contract form.

This new "Net Weight Contract" was duly accepted by the Liverpool Cotton Association, on October 12th, 1908, and it is anticipated that the Exchanges at Bremen and Havre will also accept it. The new Contract binds the seller to an agreement that the cotton shall be charged net weight, so that the bands for covering the bale do not enter into the bargain. Heretofore (and still, of course, under the old contract) of the cotton purchased from American sources, 6 per cent. of the gross weight consists of tare, which is paid for as cotton. For instance, in a bale of 500 lb. the weight of canvas and bands is at least 22½ lb. This means that 50,000 lb. actual gross weight may be invoiced to the buyer as 50,500 lb. And if the cotton loses weight during transit, the buyer is required to pay for the 50,500 lb. as invoiced, and can only claim for any loss that reduces the total weight of the cotton below the actual 50,000 lb. There are other grievances in the older contract forms, but the above is the principal one.

Under the new system cotton is bought by weight and not by bale. For instance, instead of purchasing 100 bales, the buyer purchases 50,000 lb. net weight; and the seller has not the right to tender 5 per cent. more or less, at the contract price, but only 1 per cent. Should this 1 per cent. be exceeded either way, the difference would be settled between seller and buyer on the last day of landing. It is held by a former Presi-

dent of the Manchester Cotton Association (Mr. H. W. Macalister) that the Net Weight Contract will effect a saving to buyers, throughout the whole trade, of £4,800,000.

## TARE ON COTTON

Bought on Spot or Ex-Quay Terms.

LIVERPOOL COTTON ASSOCIATION BYE-LAW No. 25.

### WEIGHING.

SECTION 5.—All cotton shall be weighed full weight, and allowances shall be deducted in the invoice.

#### DOUBLE CANVAS.

SUB-SEC. (b).—When receiving cotton from the warehouse or quay the buyer shall have the right to demand the removal of double canvas before weighing.

SUB-SEC. (d).— . . . . . When the ordinary allowance for canvas . . . . . has been allowed in the invoice, and it is afterwards proved to be insufficient, the buyer shall be entitled to recover the deficiency, provided it amounts to  $\frac{1}{2}$  lb. per bale on the entire parcel purchased. . . . .

#### WEIGHT OF CANVAS.

SECTION 6, SUB-SEC. (a).—The canvas used for mending cotton in Liverpool shall not exceed  $2\frac{1}{2}$  lb. per yard (*lineal*), and should it be found that heavier canvas has been used, the seller shall be liable for all expense which the buyer may incur in establishing his claim for excess tare.

#### CLAIMS FOR ERRORS IN WEIGHT AND INSUFFICIENT ALLOWANCE FOR TARE.

SUB-SEC. (e).—Claims for errors in weight and insufficient tare shall be allowed at the original invoice price, if made within ten days and three months from the date of invoice, provided they are properly substantiated.

#### OVER-TARE.

When cotton is "over-tared" the buyer shall be allowed to retain excess canvas without making any allowance to the seller for the same.

☛ American cotton is frequently over-tared from 1 to  $2\frac{1}{2}$  lb. per bale; in exceptional instances, over-tares of 4 lb. and upwards have been known.

The "Cotton Season" in Liverpool ends on August 31, when all the figures are totalled, these giving the imports and exports, the sales, deliveries to spinners, and the stock.

## INTERNATIONAL COTTON STATISTICS.

### World's Spindles and Consumption of Cotton.

The annual statistics of the International Federation of Master Cotton Spinners' and Manufacturers' Associations, issued last October, showed that the estimated total spindleage of the world had been increased from 128,923,659 on August 31st, 1908, to 131,503,062 on the corresponding date of 1909. The estimated number for Great Britain was slightly less than had been given in the interim statistics issued at the end of last March, the diminution being attributed to the stoppage of old mills; but the number was 414,048 more than in 1908, and there were 1,164,680 spindles still in course of erection.

The returns of the International Federation show that of the total spinning spindles of the world 88.2 per cent. consumed during the twelve months 12,098,280 American bales—which means that, at a low estimate, the total consumption of all spindles spinning American cotton would reach over 13,000,000 bales. There were stocks in hand on August 31st of 1,887,600 bales of American; this added to 11,500,000 would show a total of 13,387,600 bales available for use to the end of next August—presuming that all stocks up to that date were exhausted, which, of course, is most improbable. At any rate over 12,000,000 bales were consumed between August 31st, 1908, and August 31st, 1909—and this in spite of the short-time that was worked in all cotton-using countries except Holland and Denmark, where the number of spindles is very small. In Great Britain, for instance, where the hours per year are about 2,775, there was a curtailed production to the extent of 517 hours (including the seven-weeks lockout, which ended in November, 1908). This, of course, was organised curtailment only. Most of the countries recorded from 200 to 300 hours of short-time.

The statistics in general indicate how effective the International Federation has already become. The United States spinners, however, still remain outside the Federation, although they use nearly one-half of the total consumption of American cotton; and even in Great Britain the owners of nearly 6,000,000 spindles do not comply with the request of the Federation for returns. The most faithful are the Germans.

On the next three pages will be found excerpts from the International returns:—

**CONSUMPTION OF COTTON FOR YEAR ENDING AUGUST 31st, 1909.**  
(Spinners' Returns.)

COUNTRIES	Number of Spinning Spindles in work. Actual>Returns	CONSUMPTION IN ACTUAL BALES.					TOTAL	TOTAL WORLD. Estimated Number of Spinning Spindles in work
		American	East Indian	Egyptian	Sundries	TOTAL		
GREAT BRITAIN	47,868,046	2,854,793	61,846	356,019	80,887	3,163,544	53,211,630	
GERMANY	10,070,180	1,249,826	342,190	107,004	50,087	1,748,557	10,162,908	
FRANCE	6,794,130	733,227	116,940	72,881	22,929	944,977	7,000,000	
RUSSIA	5,677,272	469,587	18,209	131,066	718,770*	1,337,642	7,800,000	
AUSTRIA	4,200,610	521,169	209,459	34,481	9,681	774,790	4,351,910	
ITALY	3,131,987	481,646	224,232	17,708	13,445	737,031	4,000,000	
SPAIN	1,702,000	216,820	32,230	17,580	26,370	293,000	1,900,000	
JAPAN	1,684,819	177,984	670,065	14,120	149,643	1,011,812	1,731,587	
SWITZERLAND	1,390,282	57,616	4,205	25,899	2,399	90,119	1,496,698	
BELGIUM	1,231,165	126,278	80,978	520	2,441	210,217	1,231,165	
PORTUGAL	450,696	43,860	820	930	17,076	62,175	450,696	
HOLLAND	424,773	67,349	17,864	none	352	85,565	424,773	
SWEDEN	377,501	61,587	8,748	480	122	70,947	450,000	
NORWAY	75,844	10,277	903	none	80	11,260	75,844	
DENMARK	77,568	19,822	2,538	none	688	23,048	77,568	
U.S. AMERICAT.	27,783,000	5,085,000†	not stated	not stated	not stated	5,085,000	27,783,000	
INDIA	1,908,679	6,184	688,622	1,319	43,121	739,218	6,800,000	
CANADA	777,422	112,500	465	1,100	none	114,065	865,293	
BRAZIL, and Other Countries	375,040	8,775	2	none	170,696‡	174,472	2,800,000	
<b>TOTAL</b>	<b>116,971,004</b>	<b>12,098,280</b>	<b>2,479,315</b>	<b>781,107</b>	<b>1,308,785</b>	<b>16,667,437</b>	<b>131,503,062</b>	
<b>TOTALS</b>								
August 31st, 1908	111,217,888	11,680,516	2,270,586	658,256	1,154,179	15,779,637	128,923,659	
August 31st, 1907	100,521,078	11,668,575	1,768,293	616,896	855,429	14,909,193	114,096,168	
August 31st, 1906	66,072,303	5,704,208	988,111	578,753	302,809	7,671,381	77,115,125	
August 31st, 1905	46,726,929	4,174,088	667,452	402,745	125,728	5,370,013	68,222,736	

\* The larger part being Russian Cotton of about 270-290 lb. each bale.

† The figures for the U.S. America have been cabled by the Census Bureau, Washington, D.C. The 5,085,000 bales of American Cotton represent bales of 500 lb. each.

... SPINNERS' RETURNS ON THE YEAR ENDING AUGUST 1909.

**STOCKS OF COTTON IN SPINNERS' HANDS on the 31st AUGUST, 1909.**  
 ("Invisible Supply"—Spinners' Returns.)

COUNTRIES	Number of Spinning Spindles. Actual Returns	STOCKS IN ACTUAL BALES.					TOTAL	TOTAL WORLD. Estimated Number of Spinning Spindles in work
		American	East Indian	Egyptian	Sundries	TOTAL		
GREAT BRITAIN ..	47,688,046	208,824	10,752	88,200	24,165	331,741	53,311,630	
GERMANY .....	10,070,180	186,924	108,168	24,296	14,281	333,669	10,162,908	
FRANCE .....	6,794,130	87,840	53,827	16,820	9,016	177,103	7,000,000	
RUSSIA .....	5,677,272	97,650	5,824	35,124	217,176*	345,644	7,800,000	
AUSTRIA .....	4,200,610	95,816	71,619	8,476	3,822	178,833	4,351,910	
ITALY .....	3,131,987	87,176	38,501	4,214	5,874	135,765	4,000,000	
SPAIN .....	1,702,000	64,600	7,920	3,450	8,340	84,310	1,900,000	
JAPAN .....	1,654,819	64,449	233,346	9,560	17,911	325,256	1,731,587	
SWITZERLAND ..	1,390,282	11,356	1,009	9,278	22,974	46,659	1,486,698	
BELGIUM .....	1,231,165	17,830	28,012	262	455	46,659	1,231,165	
PORTUGAL .....	450,696	5,983	300	155	1,620	8,058	450,696	
HOLLAND .....	424,773	5,784	3,723	175	1,720	9,682	424,773	
SWEDEN .....	377,501	13,065	3,640	706	248	17,659	450,000	
NORWAY .....	75,844	1,229	378	40	1,647	75,844	75,844	
DENMARK .....	77,558	498	122	none	125	77,558	77,558	
U. S. AMERICA†	27,783,000	908,000†	not stated	not stated	not stated	908,000	27,783,000	
INDIA .....	1,808,679	189,559	539	539	14,630	206,422	5,800,000	
CANADA .....	777,422	24,777	212	740	none	25,729	855,293	
MEXICO, BRAZIL, and Other Countries	375,040	4,235	29	none	18,232†	22,495	2,600,000	
<b>TOTAL .....</b>	<b>115,971,004</b>	<b>1,887,600</b>	<b>757,041</b>	<b>201,810</b>	<b>336,941</b>	<b>3,183,392</b>	<b>131,503,062</b>	

TOTALS	August 31st, 1908 .....	August 31st, 1907 .....	August 31st, 1906 .....	August 31st, 1905 .....
	111,217,683	100,521,078	66,072,308	46,726,929
	1,543,663	2,073,386	684,282	615,745
	750,001	912,164	343,117	192,158
	153,915	140,371	107,915	83,683
	280,466	208,489	75,296	43,651
	2,728,045	3,334,410	1,210,610	935,237
	128,923,659	114,096,168	77,115,125	68,222,736

The larger part being Russian Cotton of about 270-280 lb. each bale. The figures for the U.S. America have been cabled by the Census Bureau, Washington, D.C. The 908,000 bales of American Cotton represent bales of 500 lb. each. 2,425 bales are Mexican Cotton, and 15,450 bales are Brazilian Cotton.

## COTTON SPINNING SPINDLES, 31st August, 1909. (Spinners' Returns.)

COUNTRIES	Mule Spindles in work as per Returns	Ring Spindles in work as per Returns	Short-Time*		Spindles spinning Egyptian Cotton as per Returns	Spindles spinning American, East Indian, and Sundry Cottons as per Returns	Spindles in course of Construction as per Returns	Total Number of Spindles, Returns, in work at present	TOTAL WORLD. Estimated Number of Spinning Spindles in work
			Spindles reported during year	Number of hours during year					
GREAT BRITAIN	39,383,405	8,484,641	41,862,469†	5177	13,953,296	33,914,750	1,164,680	47,868,046	63,311,630
GERMANY	6,487,669	4,582,611	6,166,366	210	1,268,062	8,802,118	182,241	10,070,180	10,162,908
FRANCE	4,081,626	2,712,604	6,794,130	23	1,360,742	5,433,388	122,392	6,794,130	7,000,000
RUSSIA	2,809,838	2,867,436	1,432,235	1,093	760,274	4,916,998	69,915	5,677,272	7,800,000
AUSTRIA	2,434,064	1,765,548	2,350,000	200	549,171	3,651,439	203,680	4,200,610	4,351,910
ITALY	768,744	2,363,243	2,056,073	253	199,080	2,932,907	191,696	3,131,987	4,000,000
SPAIN	602,000*	1,100,000*	1,702,000	July-Aug 20%	100,000*	1,602,000	not stated	1,702,000	1,900,000
JAPAN	23,698	1,631,221	1,001,348	173%	175,455	1,479,364	139,144	1,654,819	1,731,587
SWITZERLAND	1,154,706	235,576	693,000	231	794,694	595,688	none	1,390,282	1,496,698
BELGIUM	683,584	547,601	1,231,165	217	7,000	1,224,165	20,496	1,231,165	1,231,165
PORTUGAL	106,740*	344,956*	179,632	1,379	none	450,696	25,000	450,696	450,696
HOLLAND	195,619	229,154	none	513	8,000	424,773	424,773	424,773	424,773
SWEDEN	106,956	270,545	203,917	173	75,814	369,501	26,938	377,501	450,000
NORWAY	21,748	54,096	27,336	173	none	75,814	none	75,814	75,814
DENMARK	13,244	64,314	none	none	783,000*	77,558	none	77,558	77,558
U. S. AMERICA	6,000,000*	22,783,000*	not stated	not stated	27,000,000*	27,000,000*	not stated	27,783,000	27,783,000
INDIA	520,120	1,388,559	457,943	360	21,692	1,886,887	39,568	1,908,679	5,900,000
CANADA	377,347	400,975	706,308	551.4	17,000*	760,422	44,608	777,422	865,293
MEXICO, BRAZIL, and Other Countries	17,076	367,964	26,208	604	none	375,040	31,216	375,040	2,600,000
TOTAL	63,786,862	62,184,142	65,590,189	—	19,997,466	98,973,638	2,261,024	116,971,004	131,503,062

\* Approximately † Including Lock-out.



SECTION II:  
RING SPINNING  
AND  
MULE SPINNING

SUMMARIES  
OF MACHINES, DRAFTS  
PRODUCTIONS, &c.

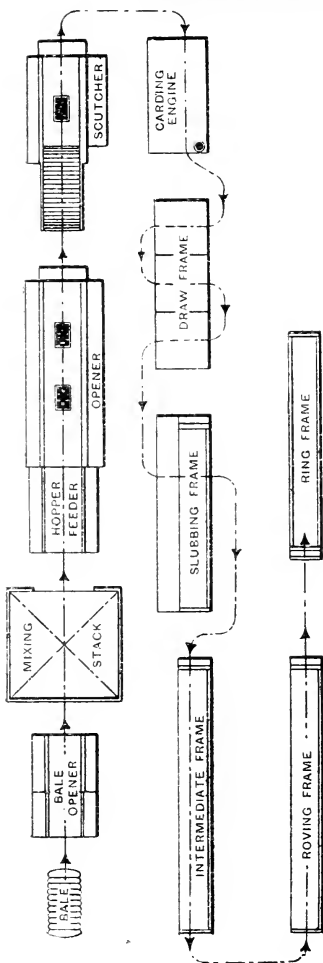

SEQUENCE OF MACHINES FOR PREPARING AND SPINNING COTTON  
INTO RING YARN.

## RING SPINNING MILL OF 50,000 SPINDLES

Spinning 20's to 40's (or an average of 30's) Yarn,  
from American Cotton.

### RAW MATERIAL.

**Cotton.**—Four different marks of cotton are generally used, having a length of staple varying from  $\frac{3}{4}$  in to  $1\frac{1}{16}$  in. Taking average gross weight of bale at 500 lb., the net weight would be about 470 lb. To this may be added the waste made on the cards, draw-frames, and fly frames when spinning weft yarns 31's to 36's counts, and twist 28's to 32's.

**Mixing.** — One Hopper Bale Breaker, opening on the average 108 bales, or (say) 53,000 lb. of cotton, in  $56\frac{1}{2}$  hours. Allow 60 lb. for dust and dirt thrown out from the above, exclusive of invisible waste.

**Blending.** — To blend the above cotton, take equal quantities from twelve bales (three of each mark), and pass the same through the Hopper Bale Breaker, thence by means of lattice creepers, to mixing or "conditioning" stacks.

**Labour.**—One man to look after the Hopper Bale Breaker, one boy to spread the cotton on the stacks, and one boy to feed from stacks through trunks to Hopper Feeders attached to Openers in the room below.

**Wages.**—Man for feeding machine, 18s. per week; boy for spreading cotton, 10s. per week; boy for feeding trunks, 14s. per week.

### BLOWING ROOM.

**Two Double Openers**, large size, each fed by automatic hopper feeders. Each Opener is provided with a beater and lap-forming apparatus.

Cylinder, 37 in. dia., making 450 revs. per min.

Beater, two blades, making 1,100 revs. per min.

Laps, 43 yards long, each weighing 50 lb.

The cotton is fed to the cylinder of each Opener by means of a lattice from the hopper feeder, through a pair of rollers, and next between the pedal and the roller. From



under the latter it is pulled out by the steel teeth of the cylinder. Arrived at the beater, the latter strikes the cotton off the pedal-nose of the machine.

**Setting.**—Set cylinder and beater  $\frac{3}{8}$  in. from the pedal-nose.

**Draft.**—The draft in each of these machines is 4.

**Production.**—Average per machine, 26,000 lb., allowing 7 per cent. for waste.

**Cleaning.**—Twice a day; the waste to be removed every morning.

**Oiling.**—All the parts every morning.

-----

**Four Single Scutchers**, fed by four laps from openers. Each scutcher is provided with beater and lap-forming apparatus.

**Beater**, with two blades, 1,100 revs. per min.

**Laps.**—43 yards long, each weighing 46 lb.

**Setting.**—The beater is set  $\frac{3}{8}$  in. from pedal-nose.

**Draft.**—4.

**Production.**—Average per machine, 12,090 lb., allowing 3 per cent. for waste—or a total of about 52,000 lb. for the four scutchers, less 10 per cent. for waste.

**Cleaning.**—Twice a day; the waste to be removed every morning.

**Oiling.**—Throughout, every morning.

-----

### Alternative Arrangements for Blowing Room for above Mill.

#### *First Alternative.*

**Two Single Vertical Openers**, each fed by Hopper Bale Breakers, the latter having filling regulating motions. These openers deliver the cotton on to travelling lattices, which in turn supply the cotton to—

**Four Hopper Feeders** attached to—

**Four Single-Beater Scutchers**, each provided with lap-forming apparatus. The laps from these are put up four at a time to—

**Five Single-Beater Finisher Scutchers**, each provided with lap-forming apparatus.

**Labour and Wages.**—One man for Bale Room, 18s. per week; one youth to feed Lattices, 12s. per week; one man to attend to Scutchers, 24s. per week.

*Second Alternative.*

**Two Hopper Bale Openers**, feeding—

**Two Hoppers**, fitted with porcupine feed tables, and connected with trunks and tubes. These supply the cotton to—

**Two Exhaust Openers**, each combined with a single-beater scutcher and lap-forming apparatus.

**Four Intermediate Scutchers**, with one beater and lap-forming apparatus to each machine.

**Four Finisher Scutchers**, with one beater and lap-forming apparatus to each machine; or, where intermediate scutchers are not used, six finisher scutchers may be employed, the production per machine being lessened accordingly.

**Dust Flues** should be as free from bends as possible, and in the down draughts care should be taken to keep them dry. Glazed bricks laid in cement are now frequently used to lessen the friction. The flues should never enter into a common flue at right angles. The area of dust flues per fan is 2 square feet. Settling chambers should be made 500 cubic feet per fan. Chimney outlet 5 sq. ft. per fan, with a minimum of 10 sq. ft.

**Labour.**—Six men.

**CARDING.**

**54 Revolving Flat Carding Engines**, 45 in. on the wire surface.

**Feed Roller.**—2½ in. dia., 1.1 rev. per min.

**Taker-in.**—9 in. dia., 510 revs. per min.

**Cylinder.**—50 in. dia., 170 revs. per min.

**Doffer.**—24 in. dia., 15 revs. per min.

**Flats.**—110, once round cylinder in 1 hr. and 10 mins.

**Wire.**—Doffer, 130's; cylinder, 110's; flats, 120's.

**Grinding.**—The cylinders and doffers should be ground every four weeks, from ½ to ¾ of an hour at a time. The flats should be ground every nine weeks.

**Stripping.**—Cylinders and doffers, twice a day. Time lost in grinding and stripping, about 2½ hours per card per week.

**Hank of Sliver.**—0.160.

**Draft.**—About 137.

**Production.**—Average per card, about 866 lb., or a total of 46,800 lb., less  $4\frac{1}{2}$  per cent. for waste, as follows:—Flats, cylinder and doffer strips, 2 per cent.; waste from under card, 2 per cent.; invisible waste, about  $\frac{1}{2}$  per cent.

**Setting.**—The flats are set as closely as possible to cylinder: that is, when a flat is slightly pressed in the middle its wire will touch that of the cylinder.

**Oiling and Cleaning.**—The cards should be oiled twice per day during the time of stripping, and afterwards should be cleaned by the card-box tenter. The loose fluff should be removed every hour, and the floor be swept every two hours.

**Labour.**—Two men at 33s. per week; two men at 20s. per week each; and three girls at 11s. to 12s., or  $6\frac{1}{2}$ d. per card, per week each, are sufficient to mind and supervise the above cards.

### DRAWING.

Six Frames, each frame made up of three heads with eight deliveries to each head: in all, 144 deliveries. Number of ends up, 6.

Rollers—

Front. $1\frac{3}{8}$ in.	Second. $1\frac{1}{2}$ in.	Third. $1\frac{3}{8}$ in.	Back. $1\frac{3}{8}$ in. dia.
Distance from centre to centre.	$1\frac{7}{16}$ in.	$1\frac{1}{2}$ in.	$1\frac{3}{8}$ in.

Top Rollers,  $1\frac{1}{8}$  in. diameter (uncovered).

Speed of Front Roller, 420 revs. per min.

**Drafts.**—1st head, 6.0; 2nd head, 6.25; 3rd head, 6.7. Sliver from last head, 0.138 hank.

**Production.**—Average per frame, about 7,450 lb. = 931 lb. per finishing delivery, or a total of 44,700 lb.; less 0.625 per cent. for waste.

**Oiling and Cleaning.**—The frames should be oiled through twice per week, and the top and bottom rollers once daily. Bottom clearers, picked once per day; top clearers, if stationary, every two hours. Rollers should be varnished once per week. Top rollers at finishing head should be renewed every six weeks.

**Labour.**—One tenter to each frame, or six tenters in all, with an average wage of 22s. per week each, equal £6 12s.

**SLUBBING.**

**Six Frames**, with 96 spindles in each frame, equal to 576 spindles in all.

**Rollers.**—Single loose boss for top row,  $1\frac{1}{4}$  in. dia.

**Lift of Spindles.**—For 10 in. bobbins.

**Weighting.**—Dead weight on front row; saddle and lever weighting for back and middle.

**Speeds.**—Spindles, 530 revs. per min.; front roller, 164 revs. per min.

**Hank Roving.**—0.62 hank.

**Turns per Inch.**—0.89.

**Drafts.**—4.49.

**Waste.**—Six lb. per frame per week.

**Production.**—Fifty-two hanks per spindle per week. Number of ends up, one per spindle.

**Oiling and Cleaning.**—All frames with long collars should be oiled once per day after first doffing. Middle and back rollers should be oiled twice per week, and cleaned once. Loose shells of front rollers and spindle footsteps should be oiled once per month. All clearers should be picked every two hours. Front rollers varnished once per month with same varnish as drawing-frame rollers.

**Labour.**—Four spindle-tenters at £1 2s. per week, and two back-tenters at 10s. 9d. per week each.

**INTERMEDIATE or 2nd SLUBBING.**

**Twelve Frames**, with 140 spindles in each frame, equal 1,680 spindles in all.

**Rollers.**—Single loose boss for top row,  $1\frac{1}{4}$  in. dia.

**Lift of Spindles.**—For 9 in. bobbins.

**Weighting.**—Dead weight on front row; saddle and lever weighting for back and middle.

**Speeds.**—Spindles, 710 revs. per min.; front roller, 120 revs. per min.

**Hank Roving.**—1.5.

**Turns per Inch.**—1.52.

**Draft.**—4.82.

**Waste.**—Eight lb. per frame per week.

**Production.**—Fifty hanks per spindle per week. Number of ends up, two per spindle.

**Oiling and Cleaning.**—All frames with long collars should be oiled once per day after first doffing. Middle and back rollers should be oiled twice per week and cleaned once. Loose shells of front rollers and spindle footsteps should be oiled once per month. All clearers should be picked every two hours.

**Labour.**—Six spindle-tenters at £1 2s. per week each, and five back-tenters at 10s. per week each.

### ROVING.

**Thirty-two Frames,** with 164 spindles in each frame, equal to 5,248 spindles in all.

**Rollers.**—Double loose boss for top rollers,  $1\frac{1}{4}$  in. dia.

**Lift of Spindles.**—For 7 in. bobbins.

**Weighting.**—Dead weight on front row; saddle and lever weighting for back and middle.

**Speeds.**—Spindles, 1,100 revs. per min.; front roller, 112 revs. per min.

**Hank Roving.**—4 and 5.

**Turns per Inch.**—2.25 and 2.7.

**Draft.**—5.33 and 6.66.

**Waste.**—Three lb. per frame per week.

**Production.**—Forty-one hanks per spindle per week. Number of Ends, two per spindle.

**Oiling and Cleaning.**—All frames with long collars should be oiled once per day after first doffing. Middle and back rollers should be oiled twice per week and cleaned once. Loose shells for front rollers and spindle footsteps should be oiled once per month. All clearers should be picked every two hours.

**Labour.**—Sixteen spindle-tenters at £1 1s. per week each, and eight back-tenters at 8s. 10d. each.

### RING FRAMES.

**140 Frames,** varying from 320 to 408 spindles in each frame, equal to 48,000 spindles in all. Twist on bobbins and weft on pirns.

**Counts.**—20's to 30's, from four-hank roving; 30's to 40's, from five-hank roving.

**Ring.**— $1\frac{5}{8}$  in. dia.

**Spindle Distance.**— $2\frac{5}{8}$  in. from centre to centre.

**Rollers.**—Front top,  $\frac{7}{8}$  in. dia. on iron; bottom front, 1 in. dia. on iron.



**Lift of Spindles.**—5 in.

**Speeds.**—Spindles, 9,000 per min.; front roller, average 112 per min.

**Spindles.**—Self-contained flexible.

**Weighting.**—Dead weight for front row; back and middle self-weighting.

**Rollers.**—Single boss.

**Roving.**—All counts spun from single rovings.

**Production.**—Average, 35 hanks for 36's counts.

**Turns per Inch.**—26.

**Waste.**—About 2½ per cent. on production.

**Travellers.**—20's to 26's, 3/0; 30's, 4/0; 34's, 5/0; 38's, 6/0; 40's, 7/0.

**Rollers.**—One newly-covered roller is required per frame per week.

**Doffing.**—About 1½ minutes' time must be allowed from stopping to starting each frame when doffing.

**Oiling.**—Rollers oiled every morning; spindles oiled and cleaned every four weeks.

**Labour.**—One tenter minds 600 spindles. Average wage, 16s. 9d. per week. Total, £67 for 80 tenters.

## ACCESSORIES

### For a Mill of the above Capacity.

Complete Roller-Covering Apparatus, made up of the following articles:—

Cutting Board and Slab.

Cranked Knife.

Large and small Scissors (one pair of each).

1 Leather Piecing Stand and Rollers.

1 Glue Kettle, Stand, and Brush.

1 Pair Dividing Compasses.

1 Drawing-on Machine with Springs.

1 Roller-ending Machine.

1 Roller Evening Machine.

1 Storage Stand for Storing and Conditioning Covered Rollers.

250 yards Roller Cloth.

100 yards Clearer Cloth.

100 doz. Roller Skins.

8 gallons Roller Varnish, Roller Cement, and Glue.

1 Mounting and Stretching Machine for Clothing the Carding Engine Cylinders, along with Punch, Wire Puller, Pincers, Knife, and Tack Hammer.



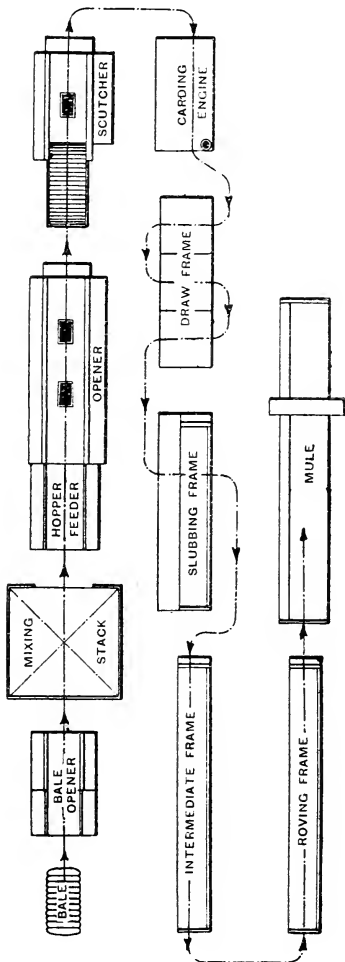

SEQUENCE OF MACHINES FOR PREPARING AND SPINNING COTTON INTO MULE YARN.

## MULE SPINNING MILL OF 80,000 SPINDLES

Spinning on an average 60's Counts, from Egyptian Cotton.

### RAW MATERIAL.

**Cotton.**—Three different marks of cotton are generally used, having an average length of staple of  $1\frac{1}{4}$  inches. As large a mixing of cotton as possible should be made to ensure the greatest uniformity. Bales average 6 cwt. each. The waste made from the cards, draw frames, and fly frames may be added to the raw cotton.

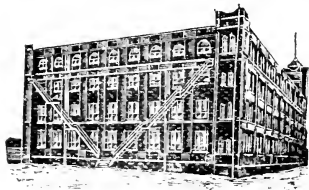

**Mixing.**—One Hopper Bale Breaker opens on an average 70 bales per week, or (say) 47,000 lb. of cotton. From this 40 lb. of dust and dirt would be taken, exclusive of invisible waste. After passing through this machine the cotton is conveyed by lattices to the mixing stacks, where it is blended.

**Labour.**—One man should look after the bale breaker and spread the cotton at the mixing. Two girls should feed the hopper feeders attached to the openers, and assist in cleaning, etc., in the blowing room.

**Wages.**—One man, £1 per week. Two girls at 12s. each, £1 4s. per week.

### BLOWING ROOM.

**Two Double Openers**, of the horizontal cylinder type, fed by automatic hopper feeders. Each opener is provided with a beater and lap-forming apparatus for laps 37 inches wide.

**Cylinders.**—18 in. dia., 750 revs. per min.

**Beaters.**—3 blades, 1,150 revs. per min.

**Laps.**—50 yards long, each  $31\frac{1}{4}$  lb., or 10 oz. per yard. The cotton is fed to the cylinders of each opener by means of lattices from the hopper feeder through a pair of rollers, and between the pedal and roller. Thence it is drawn out by the teeth of the cylinder. The beater strikes the cotton off the pedal-nose of the

machine. The machines require to work on an average 44 hours per week.

**Setting.**—Set cylinder  $\frac{1}{4}$  in. from pedal-nose.

Set beater  $\frac{1}{8}$  in. from feed roller.

**Draft.**—4.

**Production.**—22,500 lb. each machine, allowing 7 per cent. for waste.

**Cleaning.**—Twice a day. Waste to be removed every morning.

**Oiling.**—All the parts every morning.

**Four Single Scutchers**, fed by four laps, each from the openers. Each machine provided with one beater and lap-forming apparatus.

**Beater.**—Three blades, running 1,000 revs. per min.

**Laps.**—44 yards long, each weighing  $27\frac{1}{2}$  lb.

**Setting.**—Set beater from pedal-nose  $\frac{3}{8}$  in.

**Draft.**—4.

**Production.**—10,000 lb. in finished laps per machine, allowing 5 per cent. for waste. Machine to work on an average 44 hours per week.

**Cleaning.**—Twice a day. Waste droppings to be removed twice a week. Calender rollers and pedal-regulating bowls should be taken out and cleaned at least once in every two months.

**Oiling.**—Fast motions, twice a day. Slow motions, twice a week.

**Labour.**—One man, 30s. per week. Three women (12s. each), 36s. per week.

### Alternative Arrangements for Blowing Room for above Mill.

#### *First Alternative.*

**One Hopper Bale Opener**, delivering to lattices.

**Two Large-size Horizontal Cylinder Openers**, fed by automatic hopper feeders, each opener with beater and lap-forming apparatus.

**Three Single Scutchers**, each fed by 4 laps from the openers, each machine with one beater and lap-forming apparatus.

**Beater.**—Three blades, running 1,000 revs. per min.

**Labour.**—One man for bale opener, 18s. per week. Two girls for feeding lattices (at 16s.), 32s. per week.

*Second Alternative.*

**Two Combination Machines**, each consisting of a hopper bale opener, hopper feeder, horizontal cylinder opener (Buckley type), and single beater scutcher with lap-forming apparatus.

**Three Finisher Scutchers**, with one beater and lap-forming apparatus to each machine, producing laps 14 oz. per yard.

**Labour.**—Four men.

---

**CARD ROOM.**

**146 Revolving Flat Carding Engines.**—Width of wire surface, 37 in. Cylinder, 50 in. dia., 174 revs. per min. Doffer, 24 in. dia., 12 revs. per min. Taker-in, 9 in. dia. Flats, 110, once round cylinder in 50 mins. Wire:—Doffer, 130's; cylinder, 120's; Flats, 120's.

**Grinding.**—Cylinder and doffer should be ground every three weeks, four hours at a time, but lightly. Flats about the same.

**Stripping.**—Doffers, once daily. Cylinder, three times daily.

**Draft.**—160.

**Hank of Sliver.**—36.4 grains weight = 0.229 hank roving.

**Setting.**—Taker-in, to 7's gauge. Flats, to 7's gauge, Doffer, to 6's gauge. (Should be set every time ground.) Taker-in casing, to 10's gauge. Cylinder, to 22's gauge. Mote Knives, as close as possible without touching. Dish Feed, to 7's gauge. Doffer Comb, to 10's gauge.

**Production.**—236 lb. in 48 hours, less 8 per cent. for waste.

**Cleaning.**—Card fronts, once every two hours. Room floor, every two hours. Taker-in fly removed, four times a day. Front casing fly, once a week.

**Oiling.**—Machines throughout, every week. Cylinder ends, taker-in, and crank-box, every day.

**Labour.**—Six strippers and grinders.—Three at 33s. per week, £4 19s.; three at 28s. per week, £4 4s.; eight girl tenters at 10s. per week, £4; card master, 35s. to 50s. per week.

## DRAWING FRAMES.

**10 Drawing Frames**, each made up of three heads, with eight deliveries to each head. Total:—240 deliveries, 8 ends up.

(NOTE.—If possible it is an advantage to put Egyptian cotton through four heads of drawing, as better results are then obtained.)

**Rollers.—**

	Front.	Second.	Third.	Back.
	$1\frac{1}{2}$ in.	$1\frac{1}{4}$ in.	$1\frac{1}{2}$ in.	$1\frac{1}{2}$ in. dia.
Distance from centre to centre	$1\frac{1}{2}$ in.	$1\frac{3}{4}$ in.	2 in.	

**Top Rollers.**— $1\frac{3}{8}$  in. dia. when covered.

**Front Roller.**—240 revs. per min.

**Drafts.**—First head, 8; second head, 8.25; third head, 8.5. Sliver from last head, 33.3 grs. per yard = 0.25 hank.

**Production.**—3,350 lb. per finishing head, less 1 per cent. for waste = 418 lb. per finishing delivery.

**Cleaning, etc.** — Front rollers should be varnished every week. If stationary flats, pick off every two hours. Underclearers, twice a day.

**Oiling.**—Frame throughout, once weekly. Top and bottom rollers every morning.

**Labour.**—Ten minders, one to each frame. Average wage 22s., £11.

## SLUBBING FRAMES.

**10 Frames**, with 84 spindles in each frame = 840 spindles in all.

**Rollers.**—Single loose boss for front row,  $1\frac{1}{4}$  in. dia.

**Lift of Spindles.**—For 10 in. bobbins.

**Weighting.**—Dead weight on front row, saddle and lever weighting for back and middle.

**Speeds.**—Spindles, 400 revs. per min. Front roller, 138 ditto.

**Hank Roving.**—1.2 hank.

**Turns per Inch.**—0.70.

**Draft.**—4.8.

**Rollers.**—Front to middle  $1\frac{1}{8}$  in., middle to back  $1\frac{1}{8}$  in.

**Production.**—43 hanks per spindle per week. Number of ends up, 1 per spindle.

**Cleaning and Oiling.**—Collars and bobbin wheels should be oiled at first doffing every day. Top rollers every day. If front row of rollers have loose boss, oil once per week. Frames to be oiled throughout once every week, but fast motions twice every week.

All rollers to be cleaned once per week. Top clearers (if stationary) to be picked five times a day. Under-clearers once a day. Flyers should be wiped twice at each doffing—that is, once when bobbin half-full, and once when full. Front rollers varnished every week.

**Labour.**—Ten spindle tenters at 19s. per week, £9 10s. Actual time worked, 44 hours.

### INTERMEDIATE or 2nd SLUBBING.

20 Frames, with 138 spindles in each frame = 2,760 spindles in all.

**Rollers.**—Single loose boss for front row,  $1\frac{1}{4}$  in. dia.

**Lift of Spindles.**—For 9 in. bobbins.

**Weighting.**—Dead weight on front row, saddle-and-lever weighting for back and middle.

**Speeds.**—Spindles, 750 revs. per min. Front roller, 120 ditto.

**Hank Roving.**—3.3 hank.

**Turns per Inch.**—1.5.

**Draft.**—5.4.

**Rollers.**—Front to middle  $1\frac{7}{16}$  in., middle to back  $1\frac{13}{16}$  in.

**Production.**—42.8 hanks per spindle per week.

**Ends Up.**—Two per spindle.

**Cleaning and Oiling.**—Same as for Slubbing.

**Labour.**—Ten spindle tenters at 21s. per week, £10 10s. per week.

Actual time worked, 46 hours.



## ROVING FRAMES.

**40 Roving Frames**, with 220 spindles in each frame = 8,800 spindles in all.

**Rollers.**—Single loose boss for front row,  $1\frac{1}{4}$  in. dia.

**Lift of Spindles.**—For 8 in. bobbins.

**Weighting.**—Dead weight on front row; saddle-and-lever weighting for back and middle.

**Speeds.**—Spindles, 1,200 revs. per min. Front roller, 106 ditto.

**Hank Roving.**—10 to 11 hank.

**Turns per Inch.**—2.9.

**Draft.**—6 for 10 H.R., 6.6 for 11 H.R.

**Rollers.**—Front to middle  $1\frac{5}{16}$  in., middle to back  $1\frac{1}{2}$  in.

**Production.**—40 hanks per spindle per week.

**Ends Up.**—Two per spindle.

**Cleaning and Oiling.**—Same as Slubbing, but front rollers varnished every two weeks.

**Labour.**—Twenty spindle tenters at 20s. per week, and ten back tenters at 8s. per week, £24 per week.

Actual time worked according to hanks produced.

## MULES.

**40 Pairs of, or 80 Mules**, with 1,000 spindles in each mule = 80,000 spindles in all.

**Counts.**—60's.

**Spindle Distance.**— $1\frac{5}{16}$  in.

**Rollers—**

Bottom Line :	Front.	Middle.	Back.
	$1\frac{1}{16}$ in.	$\frac{3}{8}$ in.	$1\frac{1}{16}$ in.

Distance from centre to centre  $1\frac{1}{8}$  in.

Top Line :	Front.	Middle.	Back.
	$1\frac{7}{16}$ in.	$\frac{3}{4}$ in.	2 in.

**Stretch.**—Carriage travels 60 in.; total length of yarn wound on spindles, 64 in. each stretch.

**Bevel of Spindles.**—5 in.

**Speeds.**—Spindles, 9,000.

**Draft.**—12 for 10 H.R., 10.9 for 11 H.R.

**Turns per Inch.**—27.

**Production.**—0.4 lb. per spindle, or a total of 32,000 lb. per week.

**Number of Ends.**—One per spindle.

**Cleaning and Oiling.**—

Break down every last set of cops each week.

Clean top rollers and fluted rollers, and oil counter-shafts and loose pulleys, Saturday morning; one hour allowed.

Clean back of headstock and grease tin roller stands, at noon on Saturday; 15 minutes allowed.

Clean front of headstock and wipe back rollers and creels; 30 minutes allowed.

Oiling to be done every day. Time allowed—morning, 24 minutes per week; afternoon, 15 minutes per week.

Every third week, varnish front leather rollers, and clean middle and back top rollers; 30 minutes allowed.

Every six weeks, clean one side of top and bottom rollers, and grease the bottom roller necks; 30 minutes allowed.

Every third week, oil back and middle fluted rollers at breaking-down time.

Clean back and middle fluted rollers after cleaning scavengers.

At Whitsuntide and Christmas the carriages should be cleaned underneath and inside. Time allowed extends over four weeks, allowing one hour to each. (At these times the spindles and top and bottom boards should be cleaned.)

After doffing each set, clean weight hooks and wipe front roller hooks.

Carriages should be wiped down twice a day.

**Labour.**—One minder to each pair of mules. One Side Piecer to each pair of mules. One "Little" Piecer to each pair of mules.

**Wages.**—Spinning Master (average), £3. Minder (average), £2 7s. Side Piecer (average), 15s. "Little" Piecer (average), 10s. 6d. Total, £148 per full week. Wages calculated per draw.

## ACCESSORIES

For a Mill of the above Capacity.

Complete Roller-Covering Apparatus, made up of the following articles:—

- Cutting board and slab.
- Cranked knife.
- Large and small scissors (1 pair of each).
- 1 Leather-piecing Stand and Rollers.
- 1 Glue Kettle, Stand, and Brush.
- 1 pair Dividing Compasses.
- 1 Drawing-on Machine, with Springs.
- 1 Roller-ending Machine.
- 1 Roller-evening Machine.
- 1 Storage Stand for storing and conditioning Covered Roller.
- 400 yards Roller Cloth.
- 160 yards Clearer Cloth.
- 160 doz. Roller Skins.
- 12 gallons Roller Varnish. Also a quantity of Roller Cement and Glue.
- 1 Machine for Mounting and Stretching Card Clothing on Carding Engine Cylinders, with Punch, Wire Puller, Pincers, Knife, and Tack Hammer.
- 320 gross Card Mounting Tacks.
- 1 Flat-Grinding and Testing Apparatus.
- 148 complete sets of Card Clothing.
- 1 set Grinding-roller Filleting.
- 5 Stripping Rollers.
- 15 Burnishing Rollers.
- 300 Lap Rods.
- 1 pair Lap Scales.
- 3,000 Sliver Cans.
- 80 gross Slubbing Bobbins.
- 50 gross Skewers for ditto.
- 250 gross Intermediate tubes.
- 130 gross Skewers for ditto.
- 2,200 gross Roving tubes.
- 1,200 gross Skewers for ditto.
- 30 lb. Opener banding  $\frac{5}{8}$  in. dia.
- 440 lb. Card ditto,  $\frac{3}{8}$  in. dia.
- 960 lb. Mule ditto,  $\frac{3}{8}$  in. dia.
- 5,000 lb. Mule ditto,  $\frac{9}{16}$  in. dia.
- 720 lb. Mule ditto,  $\frac{3}{4}$  in. dia.
- 3,600 lb. Mule ditto,  $\frac{7}{8}$  in. dia.

- 600 lb. Mule ditto for spindles.  
 640 Set tins.  
 250 Bobbin skips.  
 160 Card brushes.  
 150 small wheel brushes.  
 150 long brushes.  
 50 doz. hand brushes.  
 40 doz. oil cans.  
 2 oil cisterns, capacity 2 gallons.  
 1 large ditto, capacity 50 gallons of oil.  
 Belting according to height and design of mill in widths  
 from 1 to 6 inches.  
 6 strap punches.  
 1 belt-splicing machine.  
 Main driving rope  $1\frac{3}{4}$  in. dia.; length, etc., according to  
 design of mill.  
 1 wrap drum for sliver.  
 1 wrap reel for yarn.  
 1 yarn-testing machine.  
 2 complete sets of screw keys and an assortment of  
 fitters' tools.  
 A SLIVER can holds from 14 to 15 lb. of cotton.

(For additional Plans showing Sequences of Machines,  
 and for other Preparations, see following pages.)

### Summary of Productions, etc., from 98,000 Mule Spindles.

For a mill of 98,000 spindles, spinning 50's Twist and  
 80's Weft, on self-acting Mules from Egyptian cotton  
 (70,000 weft spindles and 28,000 twist spindles):—

80's WEFT AND 50's TWIST.			
	Production in lb.	Hank Roving.	Drafts.
Carding Frames .....	33,200	·231	—
Drawing Frames .....	32,900	·231	—
Slubbing Frames.....	32,400	$1\frac{1}{8}$	4·87
80's WEFT.			
Intermediate Frames ..	17,734	3·5	6·2
Jack Frames.....	17,668	13	7·4
Mules .....	17,500	80's	12·3
50's TWIST.			
Intermediate Frames ..	14,272	3	5·3
Jack Frames.....	14,136	10	6·6
Mules .....	14,000	50's	10

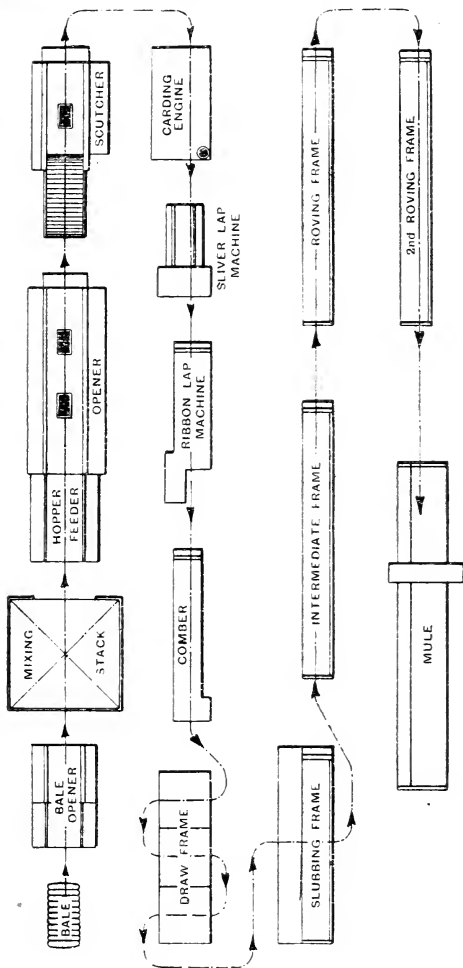

SEQUENCE OF MACHINES FOR PREPARING AND SPINNING COTTON INTO FINE COUNTS.

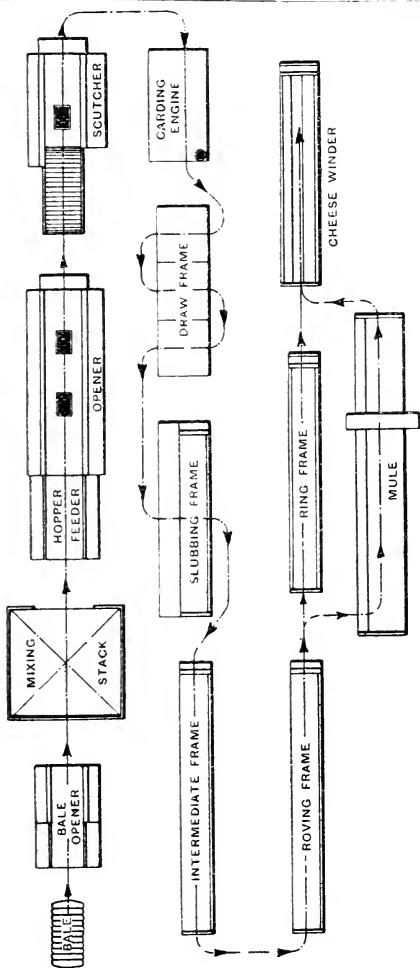

SEQUENCE OF MACHINES FOR RING AND MULE YARN  
FOR SALE IN CHEESES.

## HANK ROVINGS AND DRAFTS

For Other Preparations.

### EGYPTIAN COTTON.

60's RING YARN (COMBED).

Scutcher lap 11 oz. per yard.

Card .....	150 draft	30 grs. per yd.		277 hk. carded
Sliver lap M ...	17 ends up	2 draft	255 grs. per yd.	10½ dwt.
Ribbon " ...	6 " "	6 " "	255 " "	" "
Comber .....	8 " "	40 " "	42 " "	" "
1st head D.F....	8 " "	8 " "	42 " "	" "
2nd " ...	8 " "	8·25 " "	40 " "	" "
3rd " ...	8 " "	8·5 " "	37 " "	225 hk.
S.F. ....	1 " "	6 " "	125 grs. 30 yds.	1·35 hk.
I.F. ....	2 " "	6·3 " "	117 " 60 "	4·25 hk.
R.F. ....	2 " "	6·6 " "	70·3 " 120 "	14
Ring Sp. F.....	2 " "	8·6 " "	60's	

60's MULE YARN (CARDED).

Scutcher lap 12 oz. per yard.

Card .....	137 draft		36·4 grs. per yd.	
1st head D.F....	8 ends up	8 draft	36·4 " "	
2nd " ...	8 " "	8·25 " "	35·3 " "	
3rd " ...	8 " "	8·5 " "	33·3 " "	= 25 hk.
S.F. ....	1 " "	5 " "	198 grs. per 30 yds.	1·25 "
I.F. ....	2 " "	6 " "	130 " 60 "	3·75 "
R.F. ....	2 " "	6·4 " "	82 " 120 "	12 "
Mule .....	2 " "	10 " "		

80's WEFT MULE YARN (CARDED).

Scutcher lap 12 oz.

Card .....		137 draft	36·4 grs. per yd.	
1st head D.F....	8 ends up	8 " "	36·4 " "	
2nd " ...	8 " "	8·25 " "	35·3 " "	
3rd " ...	8 " "	8·5 " "	33·3 " "	25 hk.
S.F. ....	1 " "	6 " "	165 grs. per 30 yds.	1½ "
I.F. ....	2 " "	6 " "	108 " 60 "	4½ "
R.F. ....	2 " "	6·4 " "	67·2 " 120 "	14½ "
Mule.....	2 " "	11 " "		80's "

## 80's TWIST MULE YARN (COMBED).

Scutcher lap 11 oz. per yard.

Card .....		150 draft	30 grs. per yd.	
Sliver lap M .....	17 ends up	2 "	255 "	10½ dwt. lap
Ribbon " .....	6 "	6 "	255 "	
Comber, 18% waste	8 "	40 "	42 "	
1st head D.F. ....	8 "	8 "	42 "	
2nd " .....	8 "	8·25 "	40 "	
3rd " .....	8 "	8·5 "	37 "	= ·225 hk.
S.F. ....	1 "	6 "	185 grs. per 30 yds.	= 1·35 "
I.F. ....	2 "	6·3 "	117 " 60 "	= 4·25 "
R.F. ....	2 "	6·6 "	70·8 " 120 "	= 14 "
Mule .....	2 "	11·4 "	80's	

-----

## 100's MULE YARN (COMBED).

Scutcher lap 11 oz. per yard.

Card .....		150 draft	30 grs. per yd.	·277
Sliver lap M ...	17 ends up	2 "	255 "	10½ dwt.
Ribbon " .....	6 "	6 "	255 "	
Comber, 18% waste	8 "	40 "	42 "	
1st head D.F. ...	8 "	8·3 "	40 "	
2nd " .....	8 "	8·6 "	37 "	
3rd " .....	8 "	8·8 "	33·6 "	·24 hk.
S.F. ....	1 "	6 "	165 grs. per 30 yds.	1·44 "
I.F. ....	2 "	6·5 "	103 " 60 "	4·7 "
R.F. ....	2 "	7 "	58·8 " 120 "	16·6 "
Mule .....	2 "	12 "		

-----

## 120's MULE YARN (COMBED).

Scutcher lap 11 oz. per yard.

Card .....		150 draft	Sliver 30 grs. per yd.	·277
Sliver lap M. ...	17 ends up	2 "	255 grs. per yd.	
Ribbon " .....	6 "	6 "	255 "	
Comber " .....	8 "	40 "	42 "	
1st head D.F. ...	8 "	8 "	42 "	
2nd " .....	8 "	8·25 "	40 "	
3rd " .....	8 "	8·5 "	37 "	·225 hk.
S.F. ....	1 "	4·4 "	249 grs. per 30 yds.	1 "
I.F. ....	2 "	5 "	250 " 60 "	2½ "
R.F. ....	2 "	5·2 "	153 " 120 "	6½ "
F.J.F. ....	2 "	6·14 "	50 " 120 "	20 "
Mule .....	2 "	12 "		



## 160's MULE YARN (COMBED).

Scutcher lap 11 oz. per yard.

Card .....		150 draft	Sliver 30 grs. per yd.	
Sliver lap M. ...	17 ends up	2 "	255 grs. per yd.	
Ribbon " ...	6 "	6 "	255 "	
Comber .....	8 "	40 "	42 "	
1st head D.F. ...	8 "	8 "	42 "	
2nd " ...	8 "	8.25 "	40 "	
3rd " ...	8 "	8.5 "	37 "	.225 hk
S.F. ....	1 "	4.44 "	249 grs. per 30 yds.	1 "
I.F. ....	2 "	5.5 "	182 " 60 "	2 $\frac{3}{4}$ "
R.F. ....	2 "	5.8 "	125 " 120 "	8 "
F.J.F. ....	2 "	6.5 "	38 " 120 "	26 "
Mule.....	2 "	12.2 "		

## 150's MULE YARN (DOUBLE COMBED).

Card	20 grs. sliver per yd.			
1st Drawing head,	6 ends up. 6 draft.			
1st Lap machine,	14 ends up, 1.3 draft = lap 7 dwt. 12 grs. per yd.			
1st Comber, 20% waste;	sliver produced, 19 grs. per yd.			
2nd Lap machine,	14 ends up, draft 1.1 = lap 8 dwt. per yd.			
2nd Comber, 4% waste =	sliver 26 grs. per yd.			
1st Drawing head	6 ends up	5 draft	sliver 10 yd	= 310 grs. = 31 grs. per yd.
2nd "	6 "	5 "		34 $\frac{1}{2}$ "
3rd "	6 "	6 "		34 "
S.F. 4.4 draft	30 yds.	= 9 dwt.	11 grs.	= 1.1 hk.
I.F. 5 "	30 "	= 92 grs.	= 2.77 hk.	
R.F. 6 "	60 "	= 60 grs.	= 8.3 "	
F.J.F. 6.3 "	120 "	= 38 grs.	= 26 "	
Mule 11.5 "				= 150's.

## AMERICAN COTTON.

## 20's RING YARN.

Machine.	Ends up.	Draft,	Weight of sliver or hank roving.
Finishing Scutcher	4	—	16 oz. per yard.
Card .....	1	110	60 grs. "
D.F. 1st head .....	6	6	60 grs. "
" 2nd " .....	6	6.125	58.7 grs. "
" 3rd " .....	6	6.2	56.8 grs. " = .146 h.r.
S.F. ....	1	3.42	.5 hank roving.
I.F. ....	2	4.5	1.125 "
R.F. ....	2	5.5	3.125 "
Ring .....	1	6.4	20's.

## 30's RING YARN.

Machine.	Ends up.	Draft.	Weight of sliver or hank roving.
Finishing Scutcher	4	—	16 oz. per yard.
Card .....	1	110	60 grs. "
D.F. 1st head .....	6	6	60 grs. "
" 2nd " .....	6	6.125	58.7 grs. "
" 3rd " .....	6	6.2	56.8 grs. " = .146 h.r.
S.F. ....	1	4.2	.625 hank roving.
I.F. ....	2	4.75	1.48 "
R.F. ....	2	5.74	4.25 "
Rings .....	1	7	30's.

## 40's RING YARN.

Finishing Scutcher	4	—	16 oz. per yard.
Card .....	1	115	56 grs. "
D.F. 1st head .....	6	6	56 grs. "
" 2nd " .....	6	6.125	54.8 grs "
" 3rd " .....	6	6.25	52.6 grs. " = .158 h r.
S.F. ....	1	4.43	.7 hank roving.
I.F. ....	2	5.3	1.875 "
R.F. ....	2	5.8	5.5 "
Rings .....	1	7.3	40's.

## 50's RING YARN.

Finishing Scutcher	4	—	16 oz. per yard.
Card .....	1	132	50 grs. "
D.F. 1st head .....	6	6	50 grs. "
" 2nd " .....	6	6.25	48 grs. "
" 3rd " .....	6	6.5	44.3 grs. " = .188 h.r.
S.F. ....	1	4.2	.8 hank roving.
I.F. ....	2	5.3	2.125 "
R.F. ....	2	6.1	6.5 "
Ring .....	1	7.6	50's.

## 20's MULE YARN.

Finishing Scutcher	4	—	16 oz. per yard.
Card .....	1	110	60 grs. "
D.F. 1st head .....	6	6	60 grs. "
" 2nd " .....	6	6.125	58.7 grs. "
" 3rd " .....	6	6.2	56.8 grs. " = .146 h.r.
S.F. ....	1	3.42	.5 hank roving.
I.F. ....	2	4.5	1.125 "
R.F. ....	2	5.3	3 "
Mule .....	1	6.6	20's.

## 30's MULE YARN.

Machine.	Ends up.	Draft.	Weight of sliver or hank roving.
Finishing Scutcher	4	—	16 oz. per yard.
Card .....	110	—	60 grs. "
D.F. 1st head .....	6	6	60 grs. "
" 2nd " .....	6	6.125	58.7 grs. "
" 3rd " .....	6	6.2	56.8 grs. " = .146 h r.
S.F. ....	1	4.1	.6 hank roving.
I.F. ....	2	4.66	1.4 "
R.F. ....	2	5.35	3.75 "
Mule .....	1	8	30's.

## 40's MULE YARN.

Finishing Scutcher	4	—	16 oz. per yard.
Card .....	1	115	56 grs. "
D.F. 1st head .....	6	6	56 grs. "
" 2nd " .....	6	6.125	54.8 grs. "
" 3rd " .....	6	6.25	52.6 grs. " = .158 h r.
S.F. ....	1	4.1	.65 hank roving.
I.F. ....	2	5.38	1.75 "
R.F. ....	2	5.57	4.875 "
Mule ... ..	1	8.2	40's.

## 50's MULE YARN.

Finishing Scutcher	4	—	16 oz. per yard.
Card .....	1	115	56 grs. "
D.F. 1st head .....	6	6	56 grs. "
" 2nd " .....	6	6.125	54.8 grs. "
" 3rd " .....	6	6.25	52.6 grs. " = .158 h r.
S.F. ....	1	4.1	.65 hank roving.
I.F. ....	2	5.38	1.75 "
R.F. ....	2	5.85	5.125 "
Mule .....	1	9.75	50's.

## 60's MULE YARN.

Finishing Scutcher	4	—	16 oz. per yard.
Card .....	1	115	56 grs. "
D.F. 1st head .....	6	6	56 grs. "
" 2nd " .....	6	6.125	54.8 grs. "
" 3rd " .....	6	6.25	52.6 grs. " = .158 h r.
S.F. ....	1	4.43	.7 hank roving.
I.F. ....	2	5.3	1.875 "
R.F. ....	2	6.1	5.75 "
Mule .....	1	10.4	60's

**INDIAN COTTON.**20's RING YARN. Scutcher lap  $13\frac{1}{2}$  oz. per yard.

	Hank Roving.	Draft.	Hanks per sple. in 10 hours.	lbs. per machine or delivery in 10 hours.
Card .....	·138	93	—	177
Draw .....	·138	6	—	177
Slubber.....	$\frac{1}{2}$	3·6	8·85	—
Inter .....	$1\frac{1}{4}$	5	8·14	—
Rover.....	$3\frac{1}{2}$	5	7·08	8·5 oz. per sple. in 12 hrs.
Ring Frame	20's	6·4	8·85	7·083 ,, ,, 10 ..
Reel .....	—	—	—	102·83

20's MULE YARN. Scutcher lap  $13\frac{1}{2}$  oz. per yard.

	Hank Roving.	Draft.	Hanks per sple. in 10 hours.	lbs. per machine or delivery in 10 hours.
Card .....	·138	93	—	177
Draw .....	·138	6	—	177
Slubber.....	$\frac{1}{2}$	3·6	8·85	—
Inter .....	$1\frac{1}{4}$	5	8·14	—
Rover.....	$3\frac{1}{2}$	5	7·08	6·5 oz. per sple. in 12 hrs.
Mule .....	20's	6·4	6·77	5·416 ,, ,, 10 ..

**CHINESE COTTON.**14's RING YARN. Scutcher lap  $13\frac{1}{2}$  oz. per yard.

	Hank Roving.	Draft.	Hanks per sple. in 10 hours.	lbs. per machine or delivery in 10 hours.
Card .....	·138	93	—	177
Draw... ..	·138	6	—	177
Slubber.....	$\frac{1}{2}$	3·6	7·78	—
Inter .....	1	4	7·08	—
Rover... ..	$2\frac{1}{2}$	5	6·37	—
Ring Frame	14's	5·6	7·61	8·68 oz per sple. in 10 hrs.
Reel .....	—	—	—	88·5

**JAPANESE COTTON.**14's RING YARN. Scutcher lap  $13\frac{1}{2}$  oz. per yard.

	Hank Roving.	Draft.	Hanks per sple. in 10 hours.	lbs. per machine or delivery in 10 hours.
Card .....	·138	93	—	159·3
Draw .....	·138	6	—	159·3
Slubber . ...	$\frac{1}{2}$	3·6	7·78	—
Inter .. ..	1	4	7·08	—
Rover.....	$2\frac{1}{2}$	5	6·37	—
Ring Frame	14's	5·6	7·61	8·688 oz. per sple. in 10 hrs.
Reel .....	—	—	—	88·5

**A List of Cottons, and their Adaptation for Spinning  
Different Numbers of Yarn.**

FROM THE LOWEST TO THE HIGHEST NUMBERS

Best Sea Island.....		..150's Upwards
Best Egyptian, and the Shortest of Sea Island.....		..100's to 150's
Peeler (American) and Soft Egyptian .....		..60's to 80's
Orleans, Texas, and Soft Peruvian ....	{ These two classes are mixed together as the abundance or scarcity of each class prevails, but it is found that rough and smooth staples do not incorporate well, and hence do not make the best yarn.	} 50's to 60's
Pernams, Paraibas, Maranhams, Maceio, Rough Egyptian, and Rough Peru ..		
Puerto Cabello (W.I.*) Surinam and Bra- zilian Peru.....	{ The lower classes of American are often mixed with these varieties; Georgia or Boweds, etc., mix best with Dhollerah, Broach, Oomrawuttee, etc., but stronger kinds are often used.	} 30's to 40's
La Guayran (W.I.), Ceara (B.+) and Aracaiju (B.).....		
Dhollerah, Dhawwar, Broach, Oomrawut- tee .....	{ The strong low classes of American are best adapted to mix with West Indian, Rough Brazilians, Smyrna. African, etc.	} 16's to 28's
Smyrna, African, Per- sian .....		
Comptha, Bengal, Madras, Rangoon....		..Very low Nos.
*West Indian. †Brazilian		

There are several varieties of cotton not named in this list that would mix with one or other of the above classes, but this must be left to the discretion of the person buying such cotton.

### APPORTIONED COSTS PER LB. OF YARN.

#### Produced in Spinning 36's Twists from Carded American Cotton.

Mill furnishings, including rope, banding, strap- ping, roller skins, skips, bobbins, also coal, gas, per lb. and water .....	5/32d.
Rent, rates, insurance .....	1/16d.
Stationery, stamps, bank commission, travelling, and sundries .....	1/64d.
Painting and repairs .....	1/64d.
Carriage, brokerage, etc. ....	1/8d.
Management and wages .....	15/16d.
<hr/>	
Total Cost, exclusive of loss of cotton and de- preciation .....	1 5/16d.

#### Produced in Spinning 60's Weft from Carded American Cotton.

Mill furnishings, including rope, banding, etc., as above .....	3/8d.
Rent, rates, insurance.....	3/32d.
Stationery, stamps, etc. ....	3/16d.
Painting and repairs .....	3/64d.
Carriage, brokerage, etc. ....	5/64d.
Management and wages .....	1 11/16d.
<hr/>	
Total Cost, exclusive of loss in cotton and de- preciation .....	2 15/32d.

INSURANCE companies' statistics show that the largest number of fires in cotton mills occur in the mule spinning rooms, and are caused chiefly by friction in the machine headstocks.

IN the English Federation of Master Cotton Spinners' Associations about 38 million spindles are represented, and about 90 per cent. of these are protected by automatic sprinklers.

SECTION III:  
OPENING, SCUTCHING  
CARDING  
COMBING, DRAWING  
ETC.

## GINNING, OPENING, AND SCUTCHING MACHINERY

### COTTON GINS

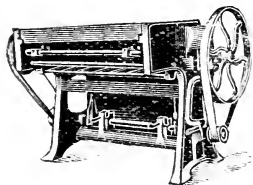

**Function.**—Removes the seeds and husks from the cotton, preparatory to the latter being made up into bales for transit.

**Types.**—There are several, but the most universally adopted are the "Macarthy" (or roller) gin, and the "Eagle" (or saw) gin.

**Application.**—The "Macarthy" gin is used for both long and short staple cotton, and is peculiarly adapted for dealing with cotton that offers difficulty in the separation of the fibres from the seeds, which often happens with such as is grown in Asia. The Eagle gin is adapted principally to short-staple cotton.

**Driving.**—Both types of gin may be driven by hand or other power. The latter is often obtained by the use of horses, mules, or oxen, walking over a circular track and operating suitable gearing.

**Description.**—The ROLLER or MACARTHY GINS, which are usually about 40 inches wide, consist of a roller covered with leather washers, or a wooden roller covered with leather, against which is pressed a "doctor" or knife blade. They are self-feeding: that is, the cotton is merely thrown into a hopper, whence it is drawn by friction between the leather roller and the doctor-knife. The cotton is then operated upon by a reciprocating beater-knife, which strikes the seed and separates it from the cotton, the seed falling through a grid provided for the purpose. The cotton is fed to the roller by the action of an automatic feeder, having a reciprocating motion. The gins are made either single-acting or double-acting, the difference between the two being that the latter is provided with two beater-knives, which are reciprocated at equal speeds, but so arranged as to rise and fall alternately.

The SAW, OR EAGLE, GIN is usually made with 60 to 70 saws, arranged on bars in sections of five saws each. The cotton, on entering the machine, encounters the teeth of the saws as they revolve, and is carried round by them until the seeds to which the cotton fibre is adherent come into contact with the parallel bars of the



gin, whereupon the saws strip the fibres from the seeds. The fibre is then removed from the saws by a revolving brush, the surface speed of which is sufficient to create a current of air, which throws the cotton along a trunk to a condenser. The object of the latter is to form the cotton into a fleece, which is deposited into any suitable receptacle. As the seeds are removed, they pass down a chute on the opposite side of the machine.

**Speeds.**—Macarthy gin, single, 700 to 800 revs. per min.; ditto, double, 550 to 600 revs. per min.; Saw ditto, 250 to 350 revs. per min.

**Pulleys.**—Macarthy gin, 6 in. to 7 in. dia.

Saw ditto, 10 saws, 9 in. dia. × 3 in. wide.

**Power.**—Macarthy gin, 1½ I.H.P.

Saw ditto, 10 saws, 1 I.H.P.

**Production.** — Macarthy gin, single-acting, when dealing with clean, long-staple cotton, such as Egyptian, Sea Island, etc., 30 to 60 lb. per hour; ditto, ditto, dealing with such as Surat, Surinam, and similar cottons, 45 lb. per hour; Saw gin, 10 saws, 45 lb. per hour.

**Floor Space.** — Macarthy gin, 5 ft. 0 in. × 3 ft. 5 in.

Saw gin, 70 saws, 6 ft. 6 in. × 7 ft. 2 in.

## BALE BREAKERS.

**Function.**—Disintegrates the cotton, partially cleans it, prepares it for mixing with other varieties, or for feeding direct to openers when mixing is not adopted.

**Types.**—There are three recognised types—namely, the spiked roller machine, the porcupine breaker, and the hopper bale breaker. The first two are now almost entirely discarded in favour of the hopper type.

**Description.**—The hopper is provided with a horizontal lattice for receiving the cotton and conveying it to a vertical lattice provided with strong steel teeth. The latter is in turn stripped of the superfluous cotton by an “evener roller” having receding teeth. The cotton that is allowed to go forward is taken off by a flap roller, and falls upon a grid or other form of grating, through which any loose dirt falls away. The cleaning properties of this

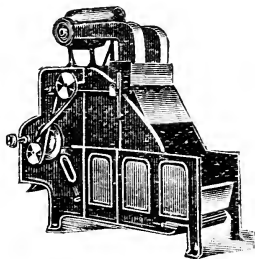

machine are assisted by the application of a fan arrangement, which takes off any foreign matter and conveys it through trunks to a suitable dust chamber or to the outside of the mill.

**Feeding.**—These machines are sometimes fed by a slow travelling lattice, carried just above the floor. This arrangement admits of a great amount of cotton being placed on the lattice and left by the attendant, who can then turn his attention to the mixings.

Another method, which is in great favour among spinners, is to provide at the back of the hopper a series of slanting grid-bars, with the top part loose and hinged to allow of a great amount of cotton being placed in the hopper. The grid allows the loose dirt to fall through, and the angle of the bars is such that the cotton beaten from the upright lattice can fall loosely to the bottom, ready to be taken up again with the fresh supply, until it is so fleecy that it can easily pass forward. The cotton in the hopper is thus constantly under agitation, and much dirt and dust is by this means removed.

**Application.**—The machines are mostly connected to mixing lattices, in which cases any moisture in the cotton is allowed to evaporate. They may also be coupled up to the openers direct, or to automatic reversing lattices feeding two hopper feeders supplying Crighton openers, when mixings are not required.

**Speed.**—450 revs. per min.

**Pulley.**—16 in. dia.  $\times$  3 in. wide.      **Power.**—2 I.H.P.

**Production.**—

A 48 in. machine, Egyptian cotton, 750 lb. in 10 mins.

Ditto, American cotton.....500 lb. in 6 to 10 mins.

**Floor Space.**—A 48 in. machine, 9 ft.  $\times$  6 ft. 6 in.

### MIXING OR CONVEYING LATTICES.

**Function.** — To receive the cotton from the bale breaker and deliver it to mixing stacks, which may be in the same room or in the room below. Or the cotton may be delivered direct to a hopper feeder or first opener.

**Speed.**—About 2,000 inches per minute when dealing with American cotton.

### ROVING WASTE OPENER.

**Function.**—Cleans and opens roving and “clearer” waste, and prepares it for mixing with the cotton coming from the bale opener. By thus mixing with the good cotton a considerable saving is effected in the raw material.

**Types.**—Various, according to the designs of the respective makers:—

(1) In which the waste to be opened is fed to the machine on an ordinary travelling lattice. It is then drawn by a pair of feed rollers to a small cylinder

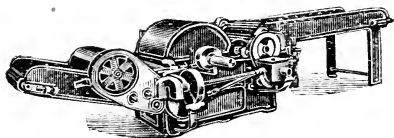

covered with wire clothing. The surface speed of the cylinder is much greater than that of the feed rollers; and as it revolves the teeth of the clothing catch the cotton in such a manner as to cause it to be carried round in short lengths. The material is then transferred from the small cylinder to a large cylinder by the aid of a knife-edge guide-plate. It is then opened, the twist is taken out, and it is delivered in a loose state in various ways to suit the requirements of the blowing-room.

(2) In which the small cylinder is dispensed with, and the material from the travelling lattice is passed between a saw-toothed fluted roller and a series of dead-weighted “dog” levers, which direct the waste to the spiked cylinder. From the latter the opened cotton is thrown by centrifugal force on to a perforated cage, 12 inches dia., whence it is delivered in the manner required.

**Application.**—The machines can be adapted to work in conjunction with any installation of blowing-room machinery. They are usually placed in close proximity to the bale breaker or opener, and are made to deliver as follows:—

Into a “skip” (skep) or movable box.

With mouthpiece for coupling up to a trunk for connecting to the delivery side of a “Crighton” opener, or into an exhaust tube.

With upright lattice delivery.

With fan and dust pipes for down draught, and with lattice delivery apron.

With pedal arrangement for regulating the feeding of the cotton.

**Speed.**—700 revs. per min.

**Pulley.**—10 in. dia.  $\times$  3½ in. wide.

**Production.**—600 lb. in 10 hours.

**Power.**—3 to 4 I.H.P.

**Floor Space.**—9 ft. 7 in.  $\times$  5 ft. 6 in. .

### THREAD EXTRACTOR.

**Function.**—Removes mechanically the hard twisted threads from the clearer waste made on mules and ring frames spinning American and short-fibre cotton.

**Description.**—The extractor proper consists of a shaft, chased from end to end, and formed with four longitudinal grooves for stripping purposes. The shaft revolves directly over two beaters, which remove therefrom the loose cotton, while the shaft retains the threads. The material is fed into a hopper, and is carried round by rotary motion given to a feed cone, until it encounters two vertical racks fitted with prongs. These latter work alternately in a vertical direction, and press the waste into the machine. As the loosened material leaves the beaters it is passed through a condensing apparatus, and is delivered in an open condition upon the floor.

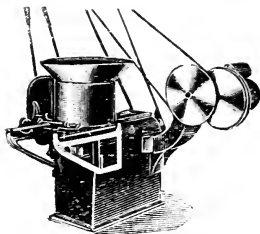

**Feeding.**—Either by hand or by an automatic feeder, the latter being preferable.

**Production.**—200 lb. per day.

**Power.**—¾ I.H.P. If with automatic feeder, 1 I.H.P.

**Floor Space.**—5 ft. 0 in.  $\times$  4 ft. 1½ in. If with automatic feeder, 6 ft. 6 in.  $\times$  5 ft. 4½ in.

## HOPPER FEEDER.

**Function.**—(1) Feeds automatically an even weight of cotton to creeper feed tables, direct to Crighton openers, or on to the lattices of large cylinder openers or scutchers. (2) Slightly opens the cotton and thus makes the next process more effective. (3) Cleans the cotton. (4) Obviates risk of fire, as heavy objects cannot pass through. (5) Ensures uniform laps.

**Description.**—Usually made with a capacious hopper, into which the loose cotton is deposited. The material is carried upwards by a spiked lattice, and is discharged (on the opposite side) upon the lattice creeper connected with the first opener or direct into the opener itself through a 9 in. pipe. The amount of cotton allowed to go forward is regulated by a spiked roller, which is made adjustable to the face of the upright lattice. The distance between the face of the lattice and the roller thereby regulates the thickness of fleece allowed to go forward. The roller, by revolving in the opposite direction, strips off the superfluous cotton, and causes it to fall back into the hopper chamber. The makers provide an arrangement for regulating the delivery of the cotton to the machine, in order to ensure a uniform volume or weight of material pressing against the upright lattice. This may be effected by lattice creepers delivering the cotton according to the requirements of the hopper. When the mixing room is overhead, the cotton may be delivered into a tube or pipe, provided with either a spider or a shaft having blades or flaps, or with a weighted door placed near the lower end. As the working reduces the weight of cotton in the hopper, the spider revolves (or the door opens) and allows more cotton to go forward.

Immediately the required amount has been allowed to enter the machine, the supply ceases automatically. One way of effecting this object is to apply a hinged door or series of bars about midway in the hopper, which press upon the cotton and are deflected according to the amount the hopper contains. Another way is to

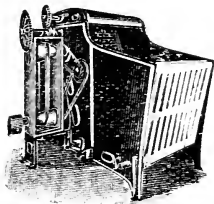

provide a separate receptacle for the cotton. This is placed inside the hopper, which rises and falls according to the weight of cotton contained therein. A third way is to attain the object through the bottom or upright lattice of the machine, which is arranged to indicate the weight; and a fourth is by making the back of the hopper movable and sensitive to any variation in the volume of cotton in the hopper. All these devices are connected with the feeding lattices, the working of which they control according to circumstances.

**Delivery.**—To ensure uniformity in delivery, the cotton may be passed through a pair of rollers and a pedal regulator, worked on the cone principle. This regulates the speed of the upright lattice according to the thickness of the web or fleece being delivered.

**Speeds.**—Stripper roller, 225 revs. per minute; eveners ditto, 100 revs. per min.; upright lattice (surface speed), 60 ft. per min., according to weight of lap required.

**Pulley.**—12 in. dia.  $\times$  2½ in. wide. **Power.**—1½ I.H.P.

**Production.**—According to requirements of opener.

**Floor Space.**—8 ft.  $\times$  6 ft.

## PORCUPINE OPENER OR CREEPER FEED TABLE.

**Function.**—Is not only employed as a feeder to openers, but serves as a preliminary cleaning and opening machine for the cotton. From this machine the cotton enters the opener in a loose, fleecy condition. These machines are only employed when treating American and Indian cottons, and are generally used as an alternative to hopper feeders.

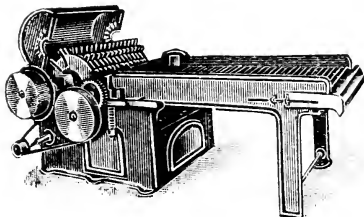

**Note.**—In some modern mills automatic feeders are used in place of the creeper feed, the users being of opinion that the former loosen the cotton equally as well, and with less injury to the staple.

**Description.**—The machines are provided with a long lattice creeper, usually 3 ft. wide, which delivers the cotton between two pairs of coarsely fluted rollers with a pedal arrangement attached. From these rollers the cotton encounters the porcupine cylinder, which is built up of a number of discs, each having steel reversible teeth arranged to project in helical lines round the cylinder. As the cylinder revolves, the teeth thereon strike the cotton from the rollers and throw it on to a grid composed of a number of bars, which surround the cylinder. Through this grid the dust and other foreign matter are discharged, and the cleaned cotton goes forward.

In place of the rollers and pedals, two pairs of coarsely-fluted rollers only may be used, in which case heavy weights or springs are employed to keep the rollers in action.

**Speed.**—800 to 1,000 revs. per min., according to dia. of cylinder.

**Pulley.**—20 in. dia.

**Power.**— $1\frac{1}{2}$  I.H.P.

**Production.**—30,000 to 40,000 lb. per week.

## DUST TRUNKS.

**Function.**—Are admirably adapted for dealing with dirty cotton. They are usually placed between the porcupine or hopper feeder and the vertical or exhaust opener; they are intended to get rid of much heavy dirt, sand, etc., from the cotton.

**Description.**—The trunk is built up of a number of bars or ribs placed transversely across the tube, with spaces between each for the dirt to fall through. Below the bars provision is made for collecting and removing the dust deposited. The cotton operated upon is drawn over the bars by the action of the fan in the opener.

The system may be augmented by the application of a travelling apron underneath the bars, working in the direction opposite to the passage of the cotton, upon which the dirt falls and is carried away. The trunks are connected with the feeders and openers respectively by means of 10 in. galvanised iron piping.

## OPENERS.

**Function.**—Opens out and loosens the fibres of the cotton, and at the same time removes therefrom a good portion of the dirt and grit it contained. The cotton is thus prepared for the subsequent process of scutching.

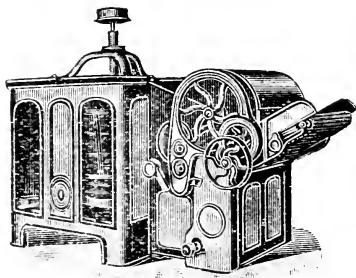

**Types.**—(1) Those with porcupine beaters working vertically — known as "Crighton openers."

(2) Those with porcupine beaters working longitudinally.

(3) Large cylinder openers known as the "Buckley" type.

(4) Exhaust openers, in which fans are placed on either side of a small porcupine beater, all working horizontally with the machine.

**Feeding.** — In several ways, according to circumstances, but chiefly by hopper feeder, porcupine, through exhaust trunks, or direct from the bale breaker.

**Delivery.**—The machines are sometimes coupled up with one or two scutcher beaters, in which case they deliver the cotton in the form of laps for feeding up and doubling at the intermediate or finishing scutcher.

### Opener with Vertical Beater.

**Adaptability.** — Has a high productive capacity, and is specially adapted for lower grades of cotton, on account of its excellent cleaning properties.

**Feeding.**—Generally by lattice or by hopper feeder through a small porcupine feeder, which delivers the loose cotton at the foot of the vertical beater. It is gradually worked up to the top or largest disc, and afterwards passes through cages on to the delivery lattices (if single openers); or to the two or three-bladed beater, through the cages and the lapping-up apparatus (if these are so combined for making laps).

The machines are sometimes made with two vertical beaters arranged to work separately or together, and may be coupled up to one or two scutcher beaters and lap-forming apparatus.



**Speed.**—Beater, 1,000 revs. per min.

**Pulley.**—12 to 14 in. dia. × 4-in. wide.

Scutcher beater, 2 blades, 1,500 revs.

” ” 3 ” 1,000 ”

” ” pulley 10 in. to 15 in. dia.

**Power.**—Single beater machine, 4 I.H.P.

Double ditto.....8 I.H.P.

**Production.**—40,000 lb. per 56½ hours if without lap apparatus.

Or, 30,000 “ “ “ if with lap apparatus.

**Floor Space.**—

Single machine, 10 ft. 6 in. by 5 ft. 6 in.

Double ditto, 16 ft. 6 in. by 5 ft. 6 in.

If with hopper feeder and porcupine, add 13 ft. to length and 1 ft. 2 in. to width. If with lattice feed and porcupine, add 10 ft. 9 in. to length and 1 ft. 2 in. to width. If coupled with single scutcher and lap apparatus for 38 in. laps, add 8 ft. 10 in. to length and 1 ft. 4 in. to width.

#### Opener with Porcupine Beaters working longitudinally.

**Adaptability.**—Generally used for the same classes of cotton as the opener with porcupine cylinder arranged transversely. Is also usually made with one or two beaters and a lap-forming apparatus.

**Feeding.**— Usually by hopper feeder, porcupine opener, or exhaust trunks.

**Speeds.**—450 to 500 revs. per min.

**Pulleys.**—16 in. dia.

**Power.**—5 to 6 I.H.P.

**Production.**—30,000 lb. per 56½ hours.

**Floor Space.**—38 in. machine, 19 ft. 3 in. × 6 ft. 2 in.

#### Large Cylinder Opener, known as the “Buckley” Type.

**Adaptability.**—Suited for the treatment of medium and higher grades of cotton. For “Sea Island” cotton it is usually made with one cylinder only; for Egyptian and the better classes of American it is made with one cylinder and one beater. The laps from this machine are sometimes taken directly to the card without passing through a single scutcher.

**Feeding.**—By lattice or hopper feeder. Are sometimes made with a feeding lattice, which delivers the cotton through pedal feed rollers on to a large cylinder (built up of discs to which are secured hardened steel plates or teeth); next over dust bars underneath the cylinder, and then through cages to the lapping-up apparatus. Or, when coupled to a scutcher part—after leaving the cages it passes through two pairs of rollers, through the beater, then through cages, on to the lapping-up apparatus

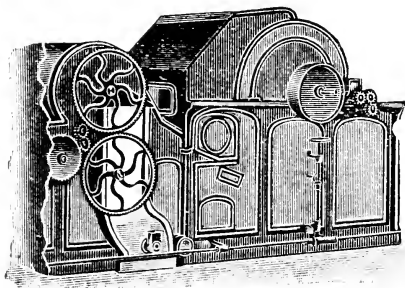

**Speeds.**—Cylinder, 450 revs. per min. for American, beater pulley, 12 in. dia.  $\times$  4½ in. wide; lap apparatus pulley, 24 in. dia.

**Pulleys.**—Cylinder pulley, 20 in. dia.  $\times$  5½ in. wide; beater pulley, 12 in. dia. by 4½ in. wide; lap apparatus pulley, 24 in. dia.

**Power.**—Single machine, 5 I.H.P.; double ditto, 10 I.H.P.

**Production.**—9,000 to 15,000 lb. per 56½ hours.

**Floor Space.**—

Single machine for 38 in. laps, 18 ft. by 6 ft. 9 in.

Double ditto.....20 ft. 6 in. by 6 ft. 9 in.

If with hopper feeder, add 4 ft. 8 in. to length.

By the application of a new form of grid (recently patented) this type of opener may now be used for almost all grades of cotton. Under the new arrangement the circular grid commences directly over the centre of the cylinder, and extends a short distance along the under side, thus encircling more than half its circumference. This addition admits of fully two-fifths more cleaning bars to the cylinder's surface. On the same basis, the

cleaning properties of the machine have been augmented, by increasing the number of horizontal bars over which the cotton passes to the cages.

### Exhaust Opener with Porcupine Cylinder arranged with Fans on either side.

**Adaptability.**—Same as machine on preceding page. Is usually provided with one beater and lap-forming apparatus.

**Feeding.**—By hopper feeder, porcupine, and trunks. Or by lattice, porcupine, or trunks.

**Speeds.**—Cylinder, 900 to 1,000 revs. per min.; beater, 1,200 revs. per min.

**Pulleys.**—Cylinder, 13 in. dia.; beater, 12 in. dia.

**Power.**—8 to 9 I.H.P.

**Production.**—25,000 to 30,000 lb. per 56½ hours.

**Floor Space.**— If with beater and lap-forming apparatus, 38 in. wide, 16 ft. 6 in. × 7 ft. 3 in.

## SCUTCHER.

**Function.**—Cleans the cotton, and forms same into laps of uniform weight and density ready for putting up at the carding engine. Is made with one or two beaters, according to circumstances, and has lap-forming apparatus attached.

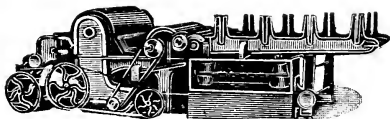

**Feeding.**—The cotton is put up at the feed end in the form of laps, a doubling of four laps being usual when used as a finisher scutcher. The material passes between rollers having pedal motion, on to the beater (which is made up of two, three, or four blades); through a pair of cages, then between three or four pressing rollers. These pressing rollers consolidate the laps, to prevent them from "licking" when being unrolled and afterwards made into one lap.

**Speeds.—**

Beater with 2 blades,	1,200 to 1,500	revs. per min.	
"    "    3    "	900	1,000	"    "
"    "    4    "	700	850	"    "

Four-bladed beaters are sometimes used for the first beaters in double scutchers. These beaters are generally made with two flat blades and two with porcupine teeth.

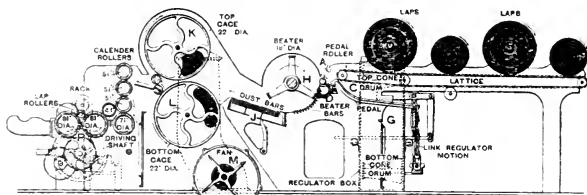

SECTION OF SCUTCHER.

**Pulleys.**—10 in. to 12 in. dia.  $\times$   $4\frac{1}{2}$  in. wide.

**Power.**—Single beater machine, 3 to 4 I.H.P.; double ditto, 6 to 8 I.H.P.

**Production.**—About 10,000 to 15,000 lb. per 56 $\frac{1}{2}$  hours, according to the weight per yard of the lap being produced.

American laps weigh 14 to 16 oz. per yard.

Egyptian laps weigh 10 to 11 oz. per yard.

Sea Islands laps weigh 9 to 10 oz. per yard.

**Floor Space.—**

Single machine for four 38 in. laps, 17 ft. by 6 ft. 6 in.

Double ditto, for four 38 in. laps, 22 ft. by 6 ft. 6 in.

**Remarks.**

For long-staple cotton the beater should strike off two feed-rollers, and for short-staple cotton from the pedal, as the latter allows the setting to be closer.

All beaters should be perfectly balanced, and "Mohler" or other specially oiled bearings be provided for the shafts to run in.

The grid-bars should have ample provision for adjustment to suit different classes of cotton.

Care should be taken that a good uniform draft is obtained. The ends of the cages should be air-tight, to ensure good selvages.

The regulators should be kept clean and in good working order, so that their action may be sensitive and reliable.

Good work consists in making even laps of uniform weight per yard. Failure to do this will give more or less uneven working throughout the mill.

Uneven laps are sometimes caused (in the case of a breaker machine) by having too little cotton in the hopper. Or a grate-bar may project a little higher than its neighbour. Insufficient fan draft also will cause bad work.

Run the beaters according to the class of cotton being worked. Take care to get the required centrifugal force.

Be careful to set the feed-rollers in relation to the beater suitable for the work required.

Care must always be taken that the feed-rollers hold the cotton firmly. Also that the beater is close enough to the feed-roller, so that the cotton does not overlap, and in time close the space between the top of the grid bars and the rollers.

The cleaning properties of a scutcher may be increased by the introduction of a special rail, having sharp-pointed teeth inserted therein. This is fixed between the feed-rollers and the grid-bars. This rail also serves as a comb for laying the fibres of cotton in parallel order.

When the counter driving-shaft is attached to the machine framing, the fast and loose pulley should be on the line shaft with the strap-lever attached; the driving is then direct to the fast pulley of the machine, and the strap from the line shaft is stopped with the machine.

## CARDING ENGINES

**Function.**—Arranges the fibres of the opened cotton approximately parallel, and removes therefrom the notes, bits of unripe seeds, neps, and all other impurities (including very short fibres and lint) from the surface of the seeds—really a system of combing—and delivers the cotton into cans in the form of sliver.

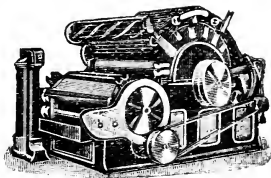

- Types.**—(1) The Revolving Flat Card.  
(2) The "Wellman" or Stationary Flat Card.  
(3) The Roller and Clearer Card.  
(4) The Combination or Union Card.

The Revolving Flat Carding Engine is the most widely adopted, its productive capacity being higher, both in quality and quantity, than the other types. The system also admits of very fine setting, and a greater wire working surface for the cotton is admissible.

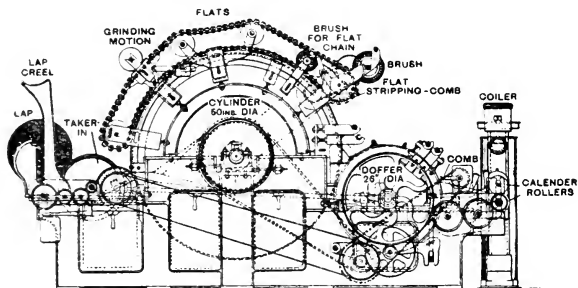

The "Wellman" Carding Engine differs from the above chiefly in the flats being stationary, and in the method of stripping the same. The flats are automatically raised up, turned over, stripped of waste, etc., by a stripping roller—then turned over again and restored to their original positions. Many of these machines are in use in carding for the finer counts; but although the output is good the production, when compared with that of the revolving flat card, is small.

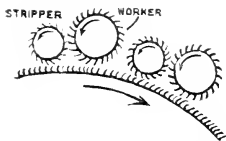

The Roller and Clearer Machine is used in carding waste and low-class cotton, because of its excellent cleaning properties. The rollers and clearers, which take the place of the flats in the other machines, are called "workers" and "strippers." The workers revolve slowly, in the direction opposite to the cylinder. Any long or tangled fibres that get upon the workers are stripped off by the rapid revolving strippers, and are put back again upon the cylinder surface. The wire of the workers points towards the back of the cylinder, while that of the strippers inclines in the same direction, as shown in sketch.

The **Union Card** is a combination of the flat and the roller machines. It is provided with one or more workers and strippers next to the taker-in, and the remaining portion of the carding surface of the cylinder is covered with flats.

### REVOLVING FLAT CARDS.

**Feeding.**—By laps from the finisher scutcher.

**Pulley.**—16 in. to 18 in. dia.  $\times$  3 in. wide.

#### Speeds, etc.

##### AMERICAN COTTON—

Feed roller,  $2\frac{1}{4}$  in. dia., 1.1 rev. per min. Taker-in, 9 in. dia., 510 revs. per min. Cylinder, 50 in. dia., 170 revs. per min. Doffer, 24 in. dia., 15 revs. per min. Flats (110), 1 rev. in 1 hour and 10 mins.

##### EGYPTIAN COTTON—

Feed roller,  $2\frac{1}{4}$  in. dia., 1.1 rev. per min. Taker-in,  $9\frac{1}{2}$  in. dia., 420 revs. per min. Cylinder, 50 in. dia., 166 revs. per min. Doffer, 24 in. dia., 10 revs. per min. Flats (110), 1 rev. in 50 mins.

##### SEA ISLAND—

Feed roller,  $2\frac{1}{4}$  in. dia., 1.1 rev. per min. Taker-in,  $9\frac{1}{2}$  in. dia., 340 revs. per min. Cylinder, 50 in. dia., 160 revs. per min. Doffer, 24 in. dia., 8.8 revs. per min. Flats (110), 1 rev. in 50 mins.

Although the doffers are given as 24 in. dia., they are sometimes made up to 27 in., with the speed varying in proportion.

#### Clothing.

##### AMERICAN COTTON—

Cylinder, 110's wire. Doffer, 130's wire. Flats, 120's wire.

##### EGYPTIAN COTTON—

Cylinder, 120's wire. Doffer, 130's wire. Flats, 120's to 130's.

##### SEA ISLAND—

Cylinder, 120's wire. Doffer, 130's wire. Flats, 130's wire.

#### Setting.

The setting for cards requires fine adjustment and careful attention to details. The gauges should be of standard sizes, usually 5/1000, 7/1000, 10/1000, or 15/1000.

A common setting is given below, but conditions should govern all:—

Doffer and Cylinder set with 7/1000 gauge.

Top Flats (front) set to 7/1000. Top flats (back) set with 10/1000. These will be found to be close enough for practical purposes.

Licker-in and Feed Rollers are usually set the same as flats—10/1000.

#### Production.—

American, 560 to 900 lb. per 56½ hours.	
Egyptian, 250 to 600 lb.     "     "	
Sea Island, 140 to 250 lb.   "     "	
Indian, 950 to 1,300 lb.     "     "	

Floor Space.—For 38 in. laps, 10 ft. × 5 ft. 3 in.

Power.—For a machine with 50 in. cylinder, 24 in. doffer, 9 in. taker-in, and 105 flats. Width on wire 38 in.

Full card at work .....	.52	I.H.P.
With doffer stopped .....	.47	"
With flats and doffer stopped .....	.42	"

### ROLLER AND CLEARER CARD.

Feeding.—By laps from the scutcher.

Pulley.—15 in. to 20 in. dia. × 3 in. wide.

Speeds, etc.—

Cylinder, 44 in. to 50 in. dia., 140 to 160 revs. per minute.
Doffer, 22 in. to 30 in. dia., 12 to 15     "     "
Workers, 4 in. to 6 in. dia., 5½ to 7½     "     "
Strippers, 3 in. to 3½ in. dia., 360 revs. per minute.
Taker-in, 8 in. to 9 in. dia., 270     "     "

Taker-in covered with diamond-shaped saw-toothed wire.

Clothing.—90's for cylinder, 100's for doffer.

90's for workers, 100's for strippers.

Power.—For a roller and clearer card, 38 in. on wire.

Full card at work .....	.66	I.H.P.
With doffer and rollers stopped .....	.57	"

Width on Wire.—

For Indian cotton .....	45 to 48 inches.
For American cotton .....	33, 41, and 45     "
For Egyptian and Sea Island ditto	36 to 38     "



## CARD CLOTHING.

The "counts" of card wire are based on the number of points or crowns covering 1 inch in length and 4 inches in width of fillet. Then always 10 crowns or 20 points to the inch longitudinally of the sheet. Thus—

Number of crowns per sq. inch  $\div$  2.5 = counts.

„ counts  $\times$  2.5 = crowns per sq. inch.

„ counts  $\times$  5 = points per sq. inch.

„ counts  $\times$  720 = points per sq. foot.

Counts of wire.	Crowns per sq. inch.	Points per sq. inch.	Crowns per sq. foot.	Points per sq. foot.
60's	150	300	21,600	43,200
70's	175	350	25,200	50,400
80's	200	400	28,800	57,600
90's	225	450	32,400	64,800
100's	250	500	36,000	72,000
110's	275	550	39,600	79,200
120's	300	600	43,200	86,400
130's	325	650	46,500	93,000

**Hank Carding suitable for Various Counts, together with Speeds, Draft, and Production.**

Cottons.	Counts.	Weight of sliver per 36in. in grs.	Hank carded	Doffer Speed.	Pro-duction per 56 hours.	Draft.
	Up to				Lbs	
Low Cottons	24's	60	.138	15 to 17	850 to 950	90 to 95
American ...	30's	60	.138	13½ } to } 11 }	600 to 850	100 to 110
Egyptian ...	44's	54	.154	11 }	360 to 550	105 to 120
	40's	54	.154	10½ }		
	to	to	to	to	200 to 325	120 to 150
Sea Islands..	60's	40	.208	9½ }		
	70's	40	.208	9 }		
	to	to	to	to		
	150's	30	.277	7 }		

**Remarks.**

To card well is to spin well.

Bad carding is generally attributable to over loading the machine or neglecting to strip.

When carding good cotton, the cylinders should be stripped three times and the doffers twice each day. For

middling cotton with a heavy production, stripping should take place four times each day.

In clothing a carding engine, care should be taken to have the tension uniform, and the winding-on should proceed steadily, so as not to rupture the wire fillet. Special machines are made for this purpose.

It is absolutely essential that the cylinder and doffers should be covered in such a manner that the fillet will not slip or blister, through change of atmosphere, working strain, or other causes.

The product of a card is governed wholly by conditions, which in turn depend largely on the quality of cotton used.

A heavy lap and long draught is considered to give better production than a card with light laps and short draft. The former does the work proportionately better. A heavy lap and slow feed gives the licker-in or cylinder a longer period to separate the fibre.

Overloading the cylinder is sure to cause more or less "nitty" carding. At the same time it fills the teeth of the flats, and thus prevents them from doing their duty to the fibre.

Keep the flats as clean and in as perfect condition as possible: for they act like a series of combs on the staple, straightening and laying the fibres parallel on the cylinder.

Burnishing of the flats should be undertaken every four or five weeks.

The cylinder and doffer should be lightly ground every two months and the flats every three months; duration of time, about six hours.

By using combination stripping brushes for the revolving flats, burnishing brushes may be dispensed with, and much of the time occupied in flat picking saved to the cardroom operative.

The grinding-roller for the flats should have careful attention, to see that the surface touches every point of the wire, and that the correct heel is imparted to the flat wire.

In selecting emery fillet for card-grinding rollers, it is an advantage to obtain that in which the spiral grooves run in opposite directions. The fillet strikes the card wire in an oblique direction, and having a keen drag the winding effect is rapid and uniform:

## LOCKING CARDING ENGINE COVERS.

The Home Office has declared carding engines to be "dangerous" machines in accordance with Section 13 (2) of the Factory and Workshops Act, and that a safety locking apparatus must be attached to every machine. An apparatus to meet this requirement and effectively safeguard operatives against accidents must:—

(1) Make it impossible for the cylinder cover to be opened before the cylinder has ceased to revolve.

(2) Make it impossible to move the strap-fork while the cover remains open and unlocked.

The following are the principles embodied in some of the arrangements invented for attaining the above objects:—

### FROM THE DRIVING PULLEY.

The driving pulley is dished out at the inner side, and is provided with a series of cam-shaped pieces, the surfaces of which make impacts with a bowl mounted on the end of a bar. This latter has a sliding movement, and, being bent outwards, operates a pivoted lever, the extreme end of which overlaps the cylinder cover, and holds it down so long as the cylinder revolves. When the cylinder stops, the cams release the bowl and allow the sliding bar to be drawn back, and with it the pivoted lever. The strap is prevented from being moved on to the fast pulley by the aid of a pivoted arm and lever arrangement, which comes into and out of contact with the sliding boss of the strap-fork. The "push-bar" employed in this system extends beyond the casing, and is free to slide upon a bracket inside the casing. When not operated, this bar is held out by a spring; and, by means of additional parts, prevents the cylinder cover from being raised. The bar is provided at the opposite extremity with a hinged finger, which abuts against a spring catch on a locking-bar. This latter engages with a projecting stud, secured to the stripping cover-guard. On the hinged finger is a flat bow-spring, which serves as a cushion, and which is in frictional contact with the card cylinder side. This contact with the moving cylinder is the controlling factor in the invention.

To prevent the strap from moving on to the fast pulley, the strap-fork bar is provided with a lever, which is connected with the cylinder-cover by a bent rod. This lever has a protruding lug, which on the lifting of the

cylinder-cover guard is brought into the path of the strap-fork, and prevents its moving over the fast pulley so long as the cover guard is open.

#### FROM THE CYLINDER SHAFT.

In this device the cover door is connected by jointed rods, one of which is connected to a crank, mounted loosely on the strap-fork rod, and the other is pivoted on a bracket secured to the machine framing. On the boss of the crank is a projection, to which is attached a spring stud. This, when the door is opened, is brought into line with a fixed projection on the strap-fork. On the cylinder shaft, and revolving therewith, is a boss carrying a loose collar, in which are studs that engage with worm-like slots grooved in the fixed boss. When the door is closed and the card is in motion, the locking lever lies in contact with and is controlled by the loose collar, and the door is locked. When the strap is transferred to the loose pulley, the door still remains locked by the loose collar; but immediately the cylinder ceases to rotate, the loose collar becomes free to be turned slightly by hand. This operation causes the loose collar to move endways, and by so doing to release the locking lever and allow the door to be opened.

#### FROM A PERFORATED RIM.

This rim is attached to the inner side of the driving pulley, and revolves with it. When the cylinder is stopped, a bar is inserted through one of the perforations for the purpose of actuating an enclosed lever, which causes a bolt to be withdrawn, thus allowing the cylinder cover to be opened. The action of opening the cover causes another bolt to lock the strap-fork, and thus prevents the machine from being started until the cover is again closed. The action of closing the cover withdraws the bolt automatically, and allows the machine to be started again.

#### REMOVING DUST FROM CARDING ENGINES.

The ill-effects arising from neglect in the removal of dust from carding engines during the stripping and grinding operations are of a two-fold character. Not only is the breathing of it injurious to the work-hands engaged, but much of the dirt and grit of which it is composed

settles upon the machines in the immediate vicinity, to the detriment of their working parts, involving excessive wear and tear and causing the production of defective work. There are now obtainable at a comparatively small cost appliances which not only prevent the dust from entering the room, but carry it away as fast as it is made.

A dust-removal scheme should embody the following two essentials: it should remove the dust directly from the point of generation, and should further accomplish this with a minimum amount of air. If the dust can be caught almost as soon as produced, it is quite possible to maintain a clear atmosphere even in a room where a very dusty process of manufacture is being carried on. By keeping the quantity of air removed, along with the dust, as small as possible, less humidity is taken out of a room where humidified air is required, and this constitutes a saving. The same feature is of value in winter time in the case of factories in which the atmosphere has to be warmed, for the reason that the small volume of air being exhausted with the dust does not increase the cost of heating.

In installations of this character the chief difficulties are the introduction of the necessary hoods or collectors.

These are very troublesome, since they have to be applied as closely as possible to the point where the dust is being produced, and yet must not interfere with the working of the machine or the freedom of the operator.

Installations usually comprise a main tube or duct, placed over the cards and extending the length of the room. This tube is provided with branch tubes, to which are attached hoods, which are placed over each machine. A powerful exhaust fan extracts the dust and discharges it outside the mill. In one arrangement, only one branch pipe is used for each row of machines. It is mounted in a carriage suspended by iron rails to the exhaust pipe, and is moved along by the operative from card to card. In another, the hood is detachable, and is carried from card to card and hooked on the respective trunks.

## COMBING: PREPARING MACHINES AND COMBERS

### DERBY DOUBLER.

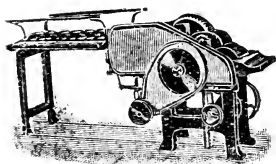

**Function.**—Unites into a sheet a given number of carded slivers, and forms them into a lap to be placed behind a second or finisher carding engine. Or the Derby Doupler may be employed in making heavy laps for ribbon lap machines, to be afterwards put behind the combing machine.

**Feeding.**—From 22 to 72 cans containing the sliver are arranged alongside a V-shaped table, and each sliver therefrom is passed over a spoon-shaped guide, which is connected up to a mechanical stop-motion. The slivers are then formed into laps of the following widths:—

22 cans	make	laps	10 in. to 13 in.	wide.
36	„	„	17 in. to 19 in.	„
60	„	„	23 in., 34 in., & 37 in.	wide.
72	„	„	41 in.	wide.

One, two, and sometimes three, of these laps are placed side by side behind the finisher carding engine, according to the width of the machine.

It is important that these laps be as near as possible of a uniform length and weight; and care should be taken that the machine stop-motion is sensitive and in good working order.

**Pulley.**—14 in.  $\times$  3 in.

**Speed.**—120 revs. per min.

**Power.**— $\frac{1}{2}$  to  $\frac{3}{4}$  I.H.P., according to width of machine.

**Production.**—1,000 to 1,600 lb. per day, according to the number and weight of laps made.

### SLIVER LAP MACHINE.

**Function.**—Unites the slivers from the carding engine, and forms them into laps  $7\frac{1}{2}$ ,  $10\frac{1}{2}$ , to 12 inches wide, ready for the ribbon lap machine, and to be eventually placed behind the combing machine.

**Note.**—When ribbon lap machines are not employed, the slivers from the cards are put through one head of

drawing before passing through the above-named machine, and the laps made thereon are taken directly to the comber.

**Feeding.**—The cans containing the slivers are taken from the card or draw frame, and a number, varying from 14 to 20, are placed behind this machine. The slivers are then passed between three pairs of drawing rollers and two pairs of calender rollers. They are then formed into laps—generally 1 inch narrower than required for the comber, so as to allow for a little spreading-out on the ribbon lap machine.

The machines are provided with mechanical stop-motions for the slivers. A full-lap or measuring motion is also attached, which operates when the required weight or size of lap is completed.

The Draft in this machine should not be more than 2.

**Pulleys.**—12 in. dia. to 16 in. dia.  $\times$  3 in. wide.

**Speed.**—200 revs. per min.

**Production.**—2,600 lb. per 56½ hours, according to weight of lap produced.

**Floor Space.**—7 ft. 9 in.  $\times$  4 ft. 6 in.

**Power.**—½ I.H.P. per machine.

### RIBBON LAP MACHINE.

**Function.**—Prepares the laps for the comber. The drawing process in the machine straightens the fibres, so that they can be held firmly by the nipper of the comber. This not only assists the comber in its work, but keeps down the quantity of waste.

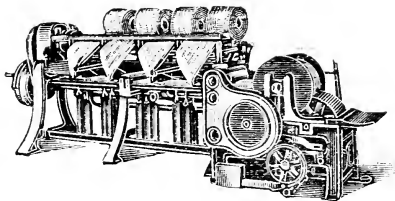

**Feeding.**—Usually takes six laps from the sliver-lap machine. The web of cotton passes between four pairs of rollers, and over a curved plate fixed directly in front of

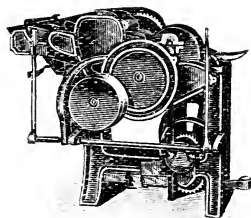

the rollers. The cotton is then delivered to a table, on which the several webs combine, and are in turn passed through calender rollers and formed into a lap.

#### APPROXIMATE WEIGHT OF LAPS

For Heilmann Combers:—

7½ in. comber laps—about 10 dwt. per yard.

8¾ in. „ „ „ 11½ „ „

10½ in. „ „ „ 13 to 14 dwt. per yard.

For "Nasmith" Comber:—Usually 10½ in. wide, and ranging from 24 to 30 dwts. per yard.

Stop-motions are provided for the length and weight of laps required, and back stop-motions to operate when the webs or laps run off.

The clearers for the rollers may be stationary or on the revolving principle.

Pulleys.—14 in. to 16 in. dia.

Speed.—260 revs. per min.

Production.—2,600 to 3,500 lb. per 56½ hours, according to weight per yard of laps made.

Floor Space.—12 ft. × 4 ft. 4 in.

Power.—¾ I.H.P.

#### DRAW FRAME AND LAP MACHINE COMBINED.

Function.—In place of the foregoing sliver-lap and ribbon-lap machines, this machine may be used for making comber laps directly from the carded sliver.

Feeding.—Consists of three or four deliveries per machine; each delivery may be fed with from 12 to 16 cans of sliver. The slivers are first passed through four pairs of draft rollers, and are afterwards combined to form a lap for the comber.

Pulleys.—16 in. to 20 in. dia.

Speed.—160 to 180 revs. per min.

Power.—1 to 1½ I.H.P.

Floor Space.—

3 delivery machines, 36 cans up = 12 ft. 2 in. × 5 ft. 3 in.

4 „ „ „ = 14 ft. 0 in. × 5 ft. 3 in.



## HEILMANN COMBER.

**Combing** is a process adopted for producing high counts, it being very effective in removing short staples. The same object was formerly attained by a second system of Carding.

**Description of Operations.**

—The Laps from the Comber or the Ribbon Lap Machine are placed on corrugated wood rollers at the back of the machine. These rollers revolve at a very slow speed, corresponding to the passage of the cotton through the machine. The cotton passes over a highly polished sliver plate on to the feed-rollers, and is fed in an intermittent manner (usually in lengths of about  $\frac{1}{4}$  inch) to a pair of nippers. These consist of upper and lower jaws, arranged to hold the cotton while it is being combed by a cylindrical comb, placed underneath them. This cylindrical comb consists of a fluted part, with a series of needles of various gauges placed in rows, the coarsest entering the cotton first, and finishing with the finest. The above action removes the short fibres, etc., not held by the nippers.

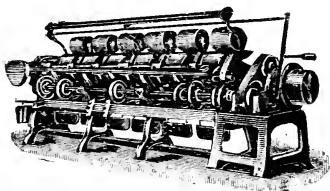

After the needles have passed through the fibres, the fluted part of the cylinder comes under the combed cotton, and at the same time a leather-covered detaching roller is lowered on this fluted part. Its duty is to carry the combed cotton on to two fixed detaching rollers. These rollers have a backward motion, and when the combed fibre is carried forward the two rollers roll backwards and join the previously combed cotton to that coming forward, thus making what is called the "overlap"—joining all the combed slivers together. While this last motion is taking place, the nippers have again opened, to allow more cotton to come forward.

The diagram shows how the cotton is combed and pieced together. There is still, however, the back portion of the sliver to comb. This is done by a comb being placed lower in the path of the cotton, the ends of which are pulled through the comb by the action of the detaching roller.

After the piecing has taken place the sliver is deposited into a sliver tin in the form of a web. It is afterwards drawn through a trumpet-mouthpiece by calender rollers, and is placed on a table, where all the ends from the different heads run side by side to the draw-box at the end of the table. In this journey they pass through three pairs of drawing rollers into a coiling motion, and are placed into cans ready for the drawing frame. All the short, "neppy" fibres and other impurities taken out are left on the cylinder or cylindrical comb.

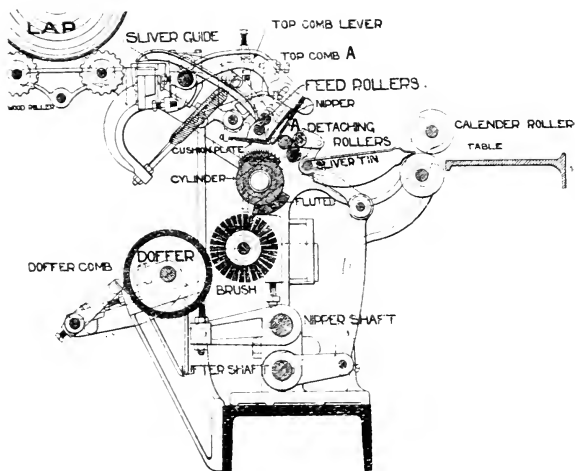

In order to keep this clean and to prevent them from getting among the good cotton, there is a brush with which the cylinder is cleaned. A doffer covered with wire cleans the brush, which in turn is stripped by a small doffing comb. The waste is then delivered into tins at the back of the machine, or on to a travelling lattice and delivered in tins at the coiler end of the machine. Sometimes a slowly revolving shaft is employed under the doffing comb, which rolls it into laps.

**Stripping Brush.**—For removing waste cotton from the top combs of combing machines. Is constructed in the form of a pair of scissors, but with the stocks containing the bristles at right angles to the jaws.

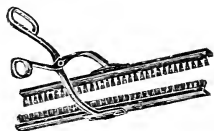

**Waste Aspirator.**—Dispenses with the doffer and stripping comb in removing the waste from the combing cylinder. A strong current of air draws the cotton along a conduit or tube on to a perforated cage. This latter serves as a screen for the removal of impurities, and as it revolves the cotton is deposited (in the form of a fleece) in a can at the end of the frame.

**Pulleys.**—12 in. dia.  $\times$  3 in. wide.

**Speed.**—

Single nip, 80 nips, or 305 revs. per min.

Double ditto, 120 nips, or 230 revs. per min.

**Production.**—

A single-nip machine, 80 nips per minute, with  $8\frac{1}{2}$ -in. laps working a 9 dwt. lap per yard, produces 40 lb. per head of Sea Island cotton in  $56\frac{1}{2}$  hours.

The same machine, working a  $10\frac{1}{2}$  dwt. lap, produces 50 lb. per head of Egyptian cotton in  $56\frac{1}{2}$  hours.

A double-nip machine, 120 nips per minute, with  $8\frac{1}{2}$ -in. laps, working a 9 dwt. lap per yard, produces 58 lb. per head of Sea Island cotton in  $56\frac{1}{2}$  hours.

The same machine, working a  $10\frac{1}{2}$  dwt. lap, produces 72 lb. per head of Egyptian cotton in  $56\frac{1}{2}$  hours.

**Floor Space.**—For  $8\frac{1}{2}$  in. lap machine, with 8 heads, 15 ft. 6 in. by 3 ft. 4 in. in the widest part.

**Power.**—8-head machine,  $\frac{7}{8}$ ths I.H.P.

**Setting Cylinders.**—Put in the cylinders and set the index wheel to 5, and with  $1\frac{1}{8}$  inch gauge between flutes of detaching roller and front edges of segments, make the cylinder fast to the shaft, and then set the detaching roller flutes to 23's gauge from flutes on segments.

Distance between flutes of detaching and feed rollers for Egyptian cotton,  $1\frac{1}{16}$  in. Long Sea Islands cotton,  $2\frac{1}{16}$  in.

Distance between flutes of detaching roller and front edge of cushion plate for Egyptian cotton,  $1\frac{3}{16}$  in. Long Sea Islands cotton,  $1\frac{7}{16}$  in.

**Setting Nippers.**—Put on the cushion plates and set them up to one thickness of writing paper from the nipper knife and to  $1\frac{3}{16}$  in. gauge from flutes of detaching roller to front edge of cushion plate (the nipper must be open and the stop screws about  $\frac{1}{4}$  in. through). Next

set the edge of the knife to 19's or 21's gauge from cylinder needles, with the right-hand screws only, and see that the distance between the detaching roller and cushion plate has not altered (a  $\frac{3}{8}$ 's gauge must be between the point of top screw and nipper stand). Next set the left-hand screws by removing the gauge, and letting point of screw touch the stand; then put on the springs. Move the cam round until the bowl is on the circular part, and put the  $\frac{3}{8}$  in. gauge again between the stop screw and stand, then screw up the nuts on one connecting rod until the gauge is just eased. Now turn the cam round until the screw points are eased from the stands, then turn the cam back again as it was and try your gauge between the knife and cylinder needles, and see that all are quite clear and to gauge.

Set Nippers to 19's wire gauge to cylinder needles for

					Egyptian Cotton.
"	"	" 21's	"	"	" Sea Islands "
"	Top combs	" 19's	"	"	segment for
"	"	" 21's	"	"	Egyptian "
"	"	" an angle of 28 degrees	"	"	" Sea Islands "
"	"	" or to 14's angle	"	"	gauge.

**Setting Feed Rollers.** — For Egyptian cotton with  $1\frac{1}{16}$  in. gauge between flutes of feed and detaching rollers make the slides fast, put on the top rollers and springs, and then set the rollers parallel to nipper knife and a convenient distance from it. For Long Sea Islands cotton a  $2\frac{1}{16}$  in. gauge must be used between flutes of feed and detaching rollers.

**Setting Brushes.** — Let the bristles touch brass of the combs of one cylinder, then make a gauge to go between the brush and cylinder shafts, and set others to this gauge.

**Brush Tins.** — Set them so as to clear the cylinder and doffer about  $\frac{1}{8}$  in.

**Lap Plates.**—Should be set clear of wood and feed rollers when the clearer brush is on.

**Lap Guides.**—Should be set  $\frac{1}{4}$  in. wider than laps and central with boss of feed roller.

**Top Detaching Rollers.** — Move the 80's wheel on cam shaft out of gear and turn round the cam shaft until the quadrant moves forward, then set the index wheel to 6, and put the 80's wheel in gear. Turn the cam shaft round and see that the roller moves forward at 6. Next clean, oil, and put the brass tubes on the covered top rollers, and put rollers in, weight them, let them rest on the segments, and bring up the lifters until the nearest will admit one thickness of paper

between it and the tubes (the bowl must be on the highest part of the cam). Then move the small slides on the lifters until each will admit one thickness of paper like the first one, and set the cam so that the roller will touch segment at  $6\frac{1}{2}$ .

**Fluted Top Detaching Rollers.**—Should be set with the greatest care so that the flutes are parallel with the flutes of bottom roller, and quite clear from the leather roller when same is touching segment.

**Top Combs, etc.**—For Egyptian cotton set the top combs to 19's gauge from segments of cylinder and to 28 degrees angle or 14's angle of top comb gauge. For Sea Islands cotton set the top combs to 21's gauge. Put on the sliver plate and gear up all the draw-box, coiler, and wood rollers, set the doffer combs, and gear up the doffer shaft.

**Notes.**—Be sure that all screws, etc., are well screwed up, and that all bearings are well oiled and the cams well greased, and mind the combs do not get damaged. The greater the angle of the combs, the greater the waste; later the nipper closes, ditto; late feeding, ditto; and close setting, ditto. Curling is caused by the detaching roller being badly covered or being short of lubrication, and the top covered roller not touching cylinder segment at the proper time; or top fluted detaching roller not being set perfectly parallel with the flutes of bottom roller.

### THE "WHITIN" COMBER.

The principles embodied in this comber are practically the same as in the single-nip Heilmann type. The differences are chiefly in simplification of the working parts, and other structural details. It is a machine capable of running at a very high speed, with a noteworthy absence of vibration. This increased speed not only enhances the output but facilitates the adoption of the machine in mills spinning fine yarns from American cotton.

**Pulleys.**—12 in. dia., 3 in. wide, 2.66 revs. of driving pulley to one nip. Speed of machine depends upon class of cotton and quality of product. For average work, from 120 to 130 nips per minute.

**Cam Shaft.**—1 revolution to 2 nips.

**Production.**—On long-staple cotton, 700 to 1,000 lb. per week of 55 hours.

**Floor Space.**—17 ft. 6 in. long  $\times$  3 ft. 6 in. wide.

**Power.**— $\frac{5}{8}$ -H.P. at 135 nips per minute.

### THE "NASMITH" COMBER.

Is a modification of the Heilmann machine, having a greater productive capacity and a wider range of adaptability. The mechanism is not so complex; and as the machine commands a greater overlap in the piecings, it can be arranged to comb any length of staple, from  $\frac{1}{4}$  in. to 2 in. The machine can be set to take out from 8 to 25 per cent. of waste, according to requirements; but the usual practice to ensure good results is to take out 15 per cent. The machine also differs from the Heilmann Comber in the following details:—

There is no fluted segment on the cylinder.

The opening and closing of the nipper, the raising and lowering of the top comb, and the rotation of the feed-roller, are all worked from the reciprocating motion of the nipper, which latter is driven by a crank.

The leather-covered roller never comes into contact with the cylinder, but rests upon the bottom roller, from which it receives both its rotary and its to-and-fro motion.

The position of the detaching roller is the same as in the Heilmann machine, except that it rotates longer during each stroke.

The setting also is different.

#### Description of Operation.

The laps from the ribbon lap machine are placed on corrugated wood rollers at the back of the comber. These rollers revolve at a very slow intermittent speed, corresponding to that of the feed rollers. After passing over plates to the feed rollers, the cotton is fed intermittently to a pair of nippers, which hold it while being combed.

The combing cylinder consists of a plain cylindrical part, and 17 rows of needles of different gauges. These latter are arranged so that the coarsest needles enter the cotton first, and are followed up by the finer ones. The object of the cylinder is to remove the short fibres, neps, dust, etc., not held by the nippers. Before all the needles have passed through the cotton, the nipper begins to move forward towards the detaching rollers; and as the last row of needles passes underneath, the detaching rollers turn backwards and deliver the previously combed fleece between the last row of needles and the plain part of the cylinder. This latter takes the fleece underneath the roller.

The nipper by this time has presented the newly combed fleece to the nip of the rollers. The rollers now

begin to turn forward and seize the tips of the fibres, pulling the remaining part through the top comb, which at the time drops down into the path of the cotton as the nippers are raised. The nippers continue to advance, and the roller to move away; but the latter is eventually overtaken by the nippers when they arrive at the destination of their respective paths. The rollers continue their rotary movement a little longer to make the separation complete, which is finally effected by the backward movement of the nipper. The nipper leaves a short portion of the combed fleece projecting from the rollers. By this means, and the foregoing mechanical movements, an overlap of from  $1\frac{1}{4}$  to 2 inches is obtained.

**Weight of Laps.**— $10\frac{1}{2}$  in. wide for various cottons.

For Superfine Sea Islands .....	12-18 dwts. per yard.
For Florida Cottons .....	18-22 " "
For Egyptian " .....	24-27 " "
For American " .....	26-32 " "

**Speeds.**—

335 revs. per min., or 86 nips, for	Finest Sea Island Cotton
350 " " " 90 " "	Florida Cotton.
370 " " " 95 " "	Egyptian and best
	American Cotton.
390 " " " 100 " "	Coarse work.

**Pulleys.**—10 in. dia.

**Production.**—Depends upon the cotton. If working at 100 beats per min., with 25 dwt. laps, and allowing 15 per cent. for waste, a six-head machine produces 800 lb. in 50 hours. Generally, if the weight (in grains) of a yard of lap (after deducting the waste) be divided by 18.7, it will give in lb. the weight produced per head per hour.

**Floor Space.**—

4 heads, $10\frac{1}{2}$ in. lap .....	10ft. 11in. $\times$ 3ft. 5in.
5 heads, $10\frac{1}{2}$ in. lap .....	12ft. 7in. $\times$ 3ft. 5in.
6 heads, $10\frac{1}{2}$ in. lap .....	14ft. 3in. $\times$ 3ft. 5in.

**Power.**—6-head machine, 0.76 I.H.P.

Owing to the small diameter and excessive length of the detaching rollers used in this type of comber, it is difficult to draw on the leather "cots" sufficiently tightly. The average leather coverer, in attempting to do this, frequently bursts the tube, thus entailing undue waste. There are, however, experts who have special machinery for this work, and whose services can be utilised—to the mill manager's advantage.

## DRAWING: THE DRAWING FRAME.

**Function and Application.** — Draws several slivers taken from the card, and attenuates them to the dimensions of one. The slivers thus become blended together, and any irregularities therein are eliminated. The slivers

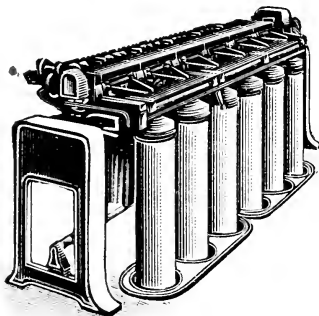

are put through the drawing heads twice, thrice, or four times, according to the class of cotton being treated. For low qualities in spinning up to 12's counts, two passages of six ends up are sufficient; and for ordinary American cotton, three passages of six ends up. For Egyptian, Sea Island, and other long-staple cottons, either of two courses is followed, namely:—Four times through with six ends up, or three times through with eight ends up. By the latter plan, one head of drawing can be dispensed with.

**Description and Feeding.**—Cans filled with the sliver from the Card or Comber (as the case may be) are placed at the back of the machine—six or eight cans to each delivery. The slivers are passed up through guides, and sometimes through a pair of "single" prevention or tension rollers, over a well-balanced spoon, to the back roller. The slivers at this point pass side by side through the four pairs of rollers. Each pair has a varying draft, the total reaching to six or eight, according to the number of ends at the back. The



slivers on leaving the feed rollers pass to a trumpet condenser—becoming a single sliver—through a pair of

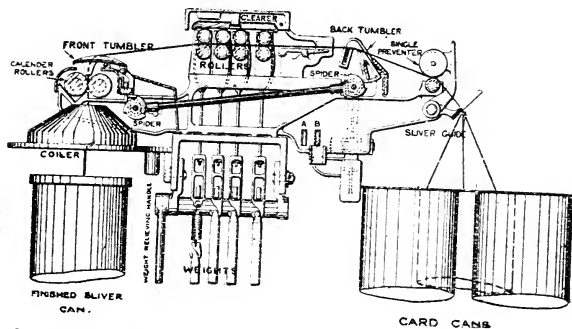

calender rollers to the coiler, from which it is finally coiled into a can ready for the Slubbing Frame.

**Draft.**—The draft for six ends up is generally 6 in the first head, increasing to 6.25 in the third head. For eight ends up, the draft is 8 at the first head, increasing to 8.5 at the third head.

DIAMETER AND SPEEDS OF ROLLERS  
For Different Counts.

Cotton.	Dia. Front roller.	Revs. per min	Counts.	Hark Roving.	Production per 56 hours.
Indian & Low					
American...	1 $\frac{1}{8}$ -1 $\frac{1}{4}$ in.	400	up to 20's	.125 to .140	900 to 1,030 lb.
American.....	1 $\frac{3}{8}$ in.	360	" 30's	.150	950 "
" .....	"	300	" 45's	.170	750 "
Egyptian .....	1 $\frac{1}{2}$ in.	280	50's-60's	.208	600 "
" .....	"	250	60's-80's	.208	510 "
" .....	"	210	80's-160's	.231	375 "
" and	"				
Sea Island..	"	210	120's	.277	325 "

The front line of rollers should be case-hardened all over; the second, third, and fourth need only be case-hardened at the necks and squares. Damage to the flutes is thus prevented and there is less wear on the necks.

When double-boss top rollers are used, the front row should have loose bosses, to prevent cutting of the leather coverings. With single-boss rollers there are only two selvages, instead of four, as in double bosses. When loose bosses are supplied to each end of single-boss rollers, they are an advantage almost equal to loose bosses throughout.

Dead-weighting of the rollers necessitates the use of a relieving motion, which must be put into operation during long stoppages, to prevent the formation of flat places on the rollers.

Great attention should be given to the rollers, to see that they are kept true and even. They should always be carefully tested by gauge before putting in the frame, especially when there is more than one boss to an arbor;—otherwise they will not draw even, and the sliver may be damaged and show a cut or uneven place.

Weak yarn is caused by over-drawing; the fibres become strained, until their natural convolutions are destroyed and the staple becomes brittle.

For short-staple cotton, or when the slivers are very light, the latter should be assisted from the cans. A device is provided for this purpose, which also acts as a preventer of "singles." Without this device, the slivers are liable to become stretched.

**Clearers.**—Are made both stationary and revolving. The latter usually consist of endless cloth, which travels over the rollers and is stripped by a comb. The latter are pieces of felt, secured to the inside of the iron covers, and stripped by hand.

Metallic instead of leather-covered top rollers may be used for certain classes of work; these effect a great saving in leather, and increase production.

**Pulleys.**—16 in. dia.  $\times$  3 in. wide.

**Speeds.**—250 revs. per min.

**Production.**—700 to 1,000 lb. per finishing delivery in 56½ hours, according to quality of cotton.

**Floor Space.**—

Width, delivery coilers, one side only, six ends up,  
4 ft. 4 in.

Width, coilers on either side, six ends up, 5 ft.

Length, according to number of deliveries.

**Rule to Ascertain Length.**—Number of dels.  $\times$  gauge. Add 20½ in. for each head + 16 in. for driving end.

**Power.**—12 deliveries per 1 I.H.P.

## USEFUL FORMULÆ.

Draft in draw frame  $\times$  Hank carding  $\div$  Number of ends put up at draw box = Hank drawing.

Number of ends put up  $\times$  Hank drawing required  $\div$  Hank carding = Draft required.

Number of ends put up  $\times$  Hank drawing  $\div$  Draft in draw frame = Hank carding required.

Number of ends put up  $\times$  Weight of carding  $\div$  Draft in frame = Weight of drawing.

Number of ends put up  $\times$  Weight of carding  $\div$  Intended weight of drawing = Draft required.

Weight of drawing  $\times$  Draft  $\div$  Number of ends put up = Weight of carding.

Required number of grains  $\times$  Change wheel  $\div$  Number of grains on frame = Change pinion required when altering from one weight to another.

Hank being made  $\times$  Pinion on frame  $\div$  Hank wanted = Change pinion required when altering from one part of a hank to another.

Crown wheel  $\times$  Back roller wheel  $\times$  Diameter of front roller  $\div$  Front roller wheel  $\times$  Change pinion  $\times$  Diameter of back roller = Draft in draw frame.

Front roller wheel  $\times$  Driver of second roller  $\times$  Diameter of second roller  $\div$  Wheel driven from front roller  $\times$  Wheel on second roller  $\times$  Diameter of front roller = Draft between first and second rollers.

Wheel on second roller  $\times$  Wheel driving third roller  $\div$  Wheel driving second roller  $\times$  Wheel on third roller = Draft between second and third rollers.

Wheel on third roller  $\times$  Wheel driving fourth roller  $\div$  Wheel driving third roller  $\times$  Wheel on fourth roller = Draft between third and fourth rollers.

Draft required  $\times$  Change pinion  $\times$  Diameter of back roller  $\div$  Crown wheel  $\times$  Back roller wheel  $\times$  Diameter of front roller = Front roller wheel necessary to give a required draft.

Front roller wheel  $\times$  Pinion wheel  $\times$  Draft  $\times$  Diameter of back roller  $\div$  Back roller wheel  $\times$  Diameter of front roller = Crown wheel for a required draft.

Front roller wheel  $\times$  Draft  $\div$  Crown wheel  $\times$  Back roller wheel = Change pinion for a required draft.

Front roller wheel  $\times$  Change pinion  $\times$  Draft  $\div$  Crown wheel = Back roller wheel for a required draft.

To find a Full Set of Wheels:—Take any two wheels for the front roller and crown wheel, then divide the crown wheel by the front roller wheel; and as the quotient stands to the draft, so does the pinion stand to the back roller wheel.

## FLYER FRAMES.

### Slubbing Frame.

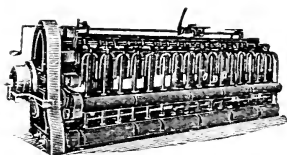

**Function.** — Receives the attenuated sliver from the Draw Frame, puts in a slight draft, and imparts to the cotton its first twist. The cotton is put up behind this machine in cans containing the coiled sliver. It is passed through three rows of draft rollers, twisted by means of

flyers, and finally wound upon wooden bobbins or tubes. It is only necessary at this stage to put enough twist

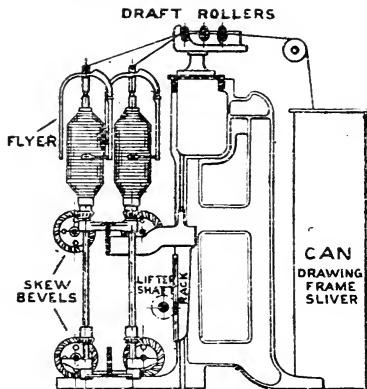

SECTION OF SLUBBING FRAME.

in the cotton to ensure good running, and to make the rove sufficiently strong to unwind in the creel of the intermediate frame without breaking.

**Pulleys.**—14 in. to 18 in. diameter.

**Speeds.**—American cotton, spindles, 550 to 650 revs. per min.

Egyptian and Sea Island, spindles, 400 to 500 revs. per min.

**Draft.**—American cotton, 4 to 5.

Egyptian cotton, 5 to 5.4.

**Production.**—In hanks per 56½ hours for the following classes of cotton:—

Low American .....	Producing	0.50 hank	=	60 hanks.
Mid. and Good American ...	"	0.75 "	=	56 "
Egyptian and Sea Island ...	"	0.75 "	=	55 "
" " ...	"	1.00 "	=	52 "

**Floor Space.**—Width, including cans, 4 ft. Length, according to number of spindles.

**Rule to Ascertain Length.**—Gauge of spindles  $\times$  half the number of spindles in frame. Add space taken up by gearing and off end (usually 3 ft. for single gearing and 5 ft. for double gearing).

**Power.**—46 to 52 spindles per I.H.P.

### Intermediate Frame.

**Function.**—Receives the slightly twisted rove from Slubbing Frame, and adds thereto a little more twist and draft. The principle of the machine is in other respects the same as that of the Slubbing Frame.

**Pulleys.**—14 in. to 16 in. dia.

**Speeds.**—American cotton, spindles, 770 to 850 revs. per min.

Egyptian cotton, spindles, 680 to 750 revs. per min.

**Draft.**—American cotton, 4.5 to 5.5.

Egyptian cotton, 5.0 to 5.75.

**Production.**—In hanks per 56½ hours for the following classes of cotton:—

Low American .....	Producing	1.5 hank	=	51 hanks.
Mid. American.....	"	1.5 "	=	50 "
American .....	"	1.75 "	=	46 "
Egyptian and Sea Island ...	"	2.5 "	=	47 "
" " ...	"	3.0 "	=	45½ "
" " ...	"	4.25 "	=	39 "

**Floor Space.** — Width, 3 ft. Length, according to number of spindles.

**Rule to Ascertain Length.**—Gauge of spindles  $\times$  half the number of spindles in frame. Add space taken up

by gearing and off end (usually 3 ft. single gearing and 5 ft. for double gearing).

**Power.**—60 spindles per I.H.P. This varies according to gauge of frame.

### Roving Frame.

**Function.** — Receives the twisted rove from the Intermediate Frame, and adds more twist and draft.

In other respects the principle is the same as that of the Intermediate Frame, except that the rove is generally taken from two bobbins per spindle to ensure strength and uniformity.

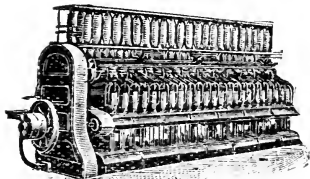

**Pulleys.**—16 in. dia.

**Draft.**—American cotton, 5 to 6.  
Egyptian cotton, 5 to 6½.

**Speeds.**—Spindles make 900 to 1,100 revs. per min., according to quality of cotton.

**Production.**—In hanks per 56½ hours for the following classes of cotton:—

American .....	Producing	4	hank=	42	hanks.
" .....	"	5	"	=39	"
" .....	"	6	"	=36	"
Egyptian and Sea Island .....	"	6	"	=36	"
" .....	"	7	"	=34	"

**Floor Space.** — Width, 3 ft. Length, according to number of spindles.

**Rule to Ascertain Length.**—Gauge of spindles × half the number of spindles in frame. Add space taken up by gearing and off end (usually 3 ft. for single gearing, and 5 ft. for double gearing).

**Power.**—70 to 80 spindles per I.H.P., according to gauge of frame.

### Fine Roving Frame.

**Function.**—Receives the twisted rove from previous machine when spinning Egyptian or Sea Island cotton. Adds more twist and draft. In other respects the same as the roving frame, and with two bobbins per spindle.

**Pulleys.**—12 in. to 16 in. dia.

**Speeds.**—Spindles make 1,000 to 1,200 revs. per min., according to quality of cotton.

**Draft.**—Should never exceed  $6\frac{1}{2}$  to 7.

**Production.**—In hanks per  $56\frac{1}{2}$  hours for the following classes of cotton:—

Egyptian .....	Producing 16 hank=	33 hanks.
Sea Island .....	” 18 ” =	32 ”
” .....	” 30 ” =	20.4 ”

**Floor Space.**—Width, 3 ft. Length, according to number of spindles.

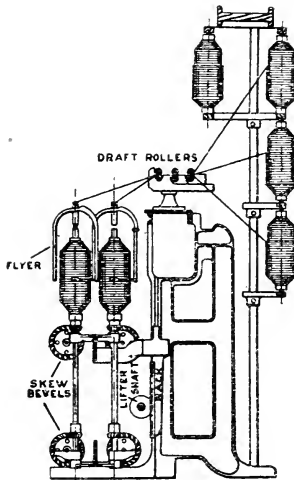

**Rule to Ascertain Length.**—Gauge of spindles  $\times$  half the number of spindles in frame. Add space taken up by gearing and off end (usually 3 ft. for single gearing and 5 ft. for double gearing).

**Power.**—90 to 100 spindles per I.H.P., according to gauge of frame.

Do not over-speed flyer frames, as excessive speeds cause defects in the rove and undue wear and tear of the machine. Excessive speed also causes more frequent breakages, and consequent loss in production.

## USEFUL FORMULÆ.

Revolutions per spindle per minute  $\div$  Inches delivered per minute = Turns per inch.

Square root of present counts  $\times$  Wheel on frame  $\div$  Square root of required counts = Twist wheel and lifter wheel.

Present counts  $\times$  Wheel on frame  $\div$  Required counts = Draft wheel.

Square root of required counts  $\times$  Wheel on frame  $\div$  Square root of present count = Ratchet wheel.

$8\frac{1}{3} \times$  Length wrapped in yards  $\div$  Weight of rove in grains = Counts or hank roving.

$8\frac{1}{3} \div$  Hank roving = Weight per yard of rove in grains.

Front roller wheel  $\times$  Pinion wheel  $\times$  Diameter of back roller  $\div$  Crown wheel  $\times$  Back roller wheel  $\times$  Diameter of front roller = Draft.

Speed of line shaft  $\times$  Diameter of pulley thereon  $\times$  Wheel on frame shaft  $\times$  Wheel on spindle shaft  $\div$  Diameter of frame pulley  $\times$  Spindle shaft wheel  $\times$  Driving wheel on spindle = Speed of spindles.

Speed of line shaft  $\times$  Diameter of driving drum  $\times$  Twist wheel on frame shaft  $\times$  Wheel on bottom cone drum end  $\div$  Front roller wheel  $\times$  Wheel on bottom cone drum  $\times$  Pulley on frame end = Speed of front roller.

Wheel on spindle end  $\times$  Wheel on spindle shaft end  $\times$  Twist wheel on same shaft  $\times$  Wheel on top cone drum shaft  $\div$  Wheel working into spindle shaft wheel  $\times$  Wheel on main shaft  $\times$  Wheel on top cone drum (opposite end)  $\times$  Front roller wheel = Number of turns of spindle for one of front roller.

Number of turns of spindle for one of front roller  $\div$  Circumference of front roller = Turns per inch.

## Multipliers of Square Root for Turns per Inch.

Cottons	Slubbing	Intermediate	Roving	Fine Roving
Sea Island ...	0.7	0.78	1.1	0.9
Egyptian .....	0.9	0.95	1.15	0.95
American .....	1.1	1.1	1.25	
Indian .....	1.3	1.2	1.25	



**Dia. of Top and Bottom Rollers for the Different Speed Frames suitable for the Different Cottons.**

Cotton	Machines	Bottom Rollers			Top Rollers		
		1st	2nd	3rd	1st	2nd	3rd
Indian .....	Slubber .....	$1\frac{1}{8}$	$\frac{7}{8}$	$1\frac{1}{8}$	$\frac{15}{16}$	$\frac{15}{16}$	$\frac{15}{16}$
	Intermediate ...	$1\frac{1}{8}$	$\frac{7}{8}$	$1\frac{1}{8}$	$\frac{7}{8}$	$\frac{7}{8}$	$\frac{7}{8}$
	Roving .....	$1\frac{1}{16}$	$\frac{13}{16}$	1	$\frac{3}{4}$	$\frac{3}{4}$	$\frac{3}{4}$
American .....	Slubber .....	$1\frac{1}{4}$	$1\frac{1}{8}$	$1\frac{1}{4}$	1	1	1
	Intermediate ...	$1\frac{1}{4}$	$1\frac{1}{8}$	$1\frac{1}{4}$	1	1	1
	Roving .....	$1\frac{1}{8}$	$\frac{7}{8}$	$1\frac{1}{8}$	$\frac{13}{16}$	$\frac{13}{16}$	$\frac{13}{16}$
Egyptian and Sea Island ...	Slubber .....	$1\frac{3}{8}$	$1\frac{1}{4}$	$1\frac{3}{8}$	$1\frac{1}{16}$	$1\frac{1}{16}$	$1\frac{1}{16}$
	Intermediate ...	$1\frac{3}{8}$	$1\frac{1}{4}$	$1\frac{3}{8}$	$1\frac{1}{16}$	$1\frac{1}{16}$	$1\frac{1}{16}$
	Roving .....	$1\frac{1}{4}$	$1\frac{1}{8}$	$1\frac{1}{4}$	$1\frac{1}{8}$	1	$1\frac{1}{8}$
Egyptian Sea Island.....	Fine Jack .....	$1\frac{1}{4}$	1	$1\frac{1}{4}$	$1\frac{1}{4}$	$1\frac{1}{16}$	2 or $2\frac{1}{4}$
		$1\frac{1}{4}$	$1\frac{1}{8}$	$1\frac{1}{4}$	$1\frac{1}{4}$	$1\frac{1}{16}$	$2\frac{1}{4}$

The setting of rollers is regulated by the length of staple being spun, etc. The thickness of the sliver being drawn and the amount of draft being put in all affect the setting, and therefore it is impossible to give a fixed distance. Thick roving and extra twist require open setting; fine and slackly twisted roving, close setting.

**Weighting.**—For Indian and American cotton separate weights to front line of rollers, and the middle and back saddles weighted, for all frames.

For Egyptian and Sea Island cotton dead-weighting to front line of roving, and fine jack with middle and back self-weighted. Sometimes this system is adopted on the intermediate frames.

Do not overweight the draft rollers. To do so not only shortens the life of the leathers, but increases the demand for power, and weaker yarn is produced.

## Approximate Hank Roving for Different Counts.

Counts	Cotton	Slubbing Frame	Intermediate Frame	Roving Frame	
		Hank Roving	Hank Roving	Mule Yarn	Ring Yarn
10-12	Indian	$\frac{5}{8}$		$1\frac{3}{4}$	
16-24	American	.5	1 $\frac{1}{2}$ to 1 $\frac{3}{4}$	2 $\frac{1}{2}$ to 3 $\frac{1}{4}$	3 to 3 $\frac{1}{2}$
26-30	"	.625	1 $\frac{3}{8}$ to 1 $\frac{1}{2}$	3 $\frac{1}{4}$ to 4 $\frac{1}{4}$	3 $\frac{3}{4}$ to 4 $\frac{1}{4}$
32-38	"	.75	1.6	4 $\frac{1}{4}$ to 4 $\frac{3}{4}$	4 $\frac{1}{2}$ to 5
40-44	"	.8	1.75	5 to 5 $\frac{1}{4}$	5 $\frac{1}{2}$ to 6
50-60	"	.875	1.82	5 $\frac{1}{4}$ to 5 $\frac{1}{2}$	7 to 7 $\frac{3}{4}$
40-50	Egyptian	$\frac{7}{8}$ to 1	2 $\frac{3}{4}$ to 3	9 to 9 $\frac{1}{2}$	
60	"	1 $\frac{1}{8}$	3 $\frac{1}{2}$	11 to 11 $\frac{1}{4}$	
70	"	1 $\frac{1}{4}$	3 $\frac{3}{4}$	12 to 13	
80	"	1 $\frac{5}{16}$ to 1 $\frac{3}{8}$	4	14	
90	"	1 $\frac{3}{5}$ to 1 $\frac{7}{16}$	4 $\frac{1}{4}$	15 to 16	
100	"	1 $\frac{1}{2}$	4 $\frac{1}{2}$	16 to 17	

## Approximate Weight of Cotton on Various Sizes of Bobbins.

Slubbing Bobbin	12in. x 6in. = 44oz.	Roving Bobbin	8in. x 4in. = 14oz.
"	11in. x 5 $\frac{1}{2}$ in. = 32oz.	"	7in. x 3 $\frac{1}{2}$ in. = 10oz.
Intermediate "	10in. x 5in. = 24oz.	"	6in. x 3in. = 7oz.
"	9in. x 4 $\frac{1}{2}$ in. = 18oz.	"	6in. x 2 $\frac{1}{2}$ in. = 5oz.

Weight of Cotton on bobbin in lb.  $\times$  Hank roving  $\times$   
 $840 \times 0.6 =$  Length in inches on bobbin.

Length on bobbin  $\times$  Twist per inch = Total twist in  
 roving on the bobbin.

Total twist on bobbin  $\div$  Revolutions of spindle per  
 minute = Minutes occupied in building the bobbin.

The above weights may be increased by the applica-  
 tion to the frames of a recently-invented shortening or  
 tapering motion, which works in conjunction with the  
 tapering rack. For example, an intermediate frame pro-  
 ducing one hank roving for 60's Egyptian cotton has been  
 found to take 1 hour 55 minutes longer to run off in the  
 roving creel than the time usually occupied in the case of  
 an ordinarily built bobbin. Thus there are fewer doff-  
 ings, and creeling is not so frequently necessary.

## Oiling, Cleaning, etc.—

Attention should be given to the oiling of the different  
 parts of the frame, and no fluff or "fly" should be  
 allowed to accumulate thereon.

Top Rollers.—Oil every two days.

Saddles and Bottom Rollers.—Every three days.

Spindles, with ordinary footsteps.—Weekly.

Spindles, with oil-retaining footsteps.—Monthly.

Long Collars.—Clean inside every nine months.

Differential Motion.—Oil every two days and clean thoroughly every six to seven weeks.

Examine leathers on rollers, and either re-cover or true up worn ones. Sliver traverse motions effect a great saving in leather, and when used should be of the variable kind, having as little "dwell" as possible at the end of each stroke.

Care should be taken that there is no vibration in the back and middle draft rollers, breakages and weaker places in the yarn being caused thereby. This often arises from want of oil in the bearings, or is due to the frame not being level.

Fluff or "fly" should be wiped off at every doffing, and the slits in the spindles should be cleaned once a month.

## WRAP TABLES.

### I.

#### WRAP TABLE FOR 15 YARDS.

From .5 to 1 Hank.

Hank	Dwts.	Grains	Hank	Dwts.	Grains	Hank	Dwts.	Grains
.5	10	10	.67	7	18.56	.84	6	4.8
.51	10	5.09	.68	7	15.82	.85	6	3.05
.52	10	0.38	.69	7	13.15	.86	6	1.34
.53	9	19.84	.7	7	10.57	.87	5	23.67
.54	9	15.48	.71	7	8.05	.88	5	22.04
.55	9	11.27	.72	7	5.61	.89	5	20.44
.56	9	7.21	.73	7	3.23	.9	5	18.88
.57	9	3.29	.74	7	0.91	.91	5	17.36
.58	8	23.51	.75	6	22.66	.92	5	15.86
.59	8	19.86	.76	6	20.47	.93	5	14.4
.6	8	16.33	.77	6	18.33	.94	5	12.97
.61	8	12.91	.78	6	16.25	.95	5	11.57
.62	8	9.61	.79	6	14.22	.96	5	10.2
.63	8	6.41	.8	6	12.25	.97	5	8.86
.64	8	3.31	.81	6	10.32	.98	5	7.55
.65	8	0.3	.82	6	8.43	.99	5	6.26
.66	7	21.39	.83	6	6.6	1.	5	5.

## II.

## WRAP TABLE FOR 15 AND 30 YARDS.

From 1 to 5's.

Hank	15 Yards		30 Yards		Hank	15 Yards		30 Yards	
	Dwts.	Grains	Dwts.	Grains		Dwts.	Grains	Dwts.	Grains
1·	5	5·	10	10·	3·1	1	16·32	3	8·64
1·1	4	17·63	9	11·20	3·2	1	15·06	3	6·12
1·2	4	8·16	8	16·33	3·25	1	14·46	3	4·92
1·25	4	4·	8	8·	3·3	1	13·87	3	3·75
1·3	4	0·15	8	0·3	3·4	1	12·76	3	1·52
1·4	3	17·28	7	10·57	3·5	1	11·71	2	23·42
1·5	3	11·33	6	22·66	3·6	1	10·72	2	21·44
1·6	3	6·12	6	12·25	3·7	1	9·78	2	19·56
1·7	3	1·52	6	3·05	3·75	1	9·33	2	18·66
1·75	2	23·42	5	22·85	3·8	1	8·89	2	17·78
1·8	2	21·44	5	18·88	3·9	1	8·05	2	16·1
1·9	2	17·78	5	11·57	4·	1	7·25	2	14·5
2·	2	14·5	5	5·	4·1	1	6·48	2	12·97
2·1	2	11·52	4	23·04	4·2	1	5·76	2	11·52
2·2	2	8·81	4	17·63	4·25	1	5·41	2	10·82
2·25	2	7·55	4	15·11	4·3	1	5·06	2	10·13
2·3	2	6·34	4	12·69	4·4	1	4·4	2	8·81
2·4	2	4·08	4	8·16	4·5	1	3·77	2	7·55
2·5	2	2·	4	4·	4·6	1	3·17	2	6·34
2·6	2	0·07	4	0·15	4·7	1	2·59	2	5·19
2·7	1	22·29	3	20·59	4·75	1	2·31	2	4·63
2·75	1	21·45	3	18·9	4·8	1	2·04	2	4·08
2·8	1	20·64	3	17·28	4·9	1	1·51	2	3·02
2·9	1	19·1	3	14·2	5·	1	1·	2	2·
3·	1	17·66	3	11·33					

## III.

## WRAP TABLE FOR ROVING 30 AND 60 YARDS,

And from 5 to 15 Hanks.

Hank	30 Yards		60 Yards		Hank	30 Yards		60 Yards	
	Dwts.	Grains	Dwts.	Grains		Dwts.	Grains	Dwts.	Grains
5·	2	2·	4	4·	7·6	1	8·89	2	17·78
5·1	2	1·01	4	2·03	7·7	1	8·46	2	16·93
5·2	2	0·07	4	0·15	7·75	1	8·25	2	16·51
5·25	1	23·61	3	23·23	7·8	1	8·05	2	16·1
5·3	1	23·16	3	22·33	7·9	1	7·64	2	15·29
5·4	1	22·29	3	20·59	8·	1	7·25	2	14·5
5·5	1	21·45	3	18·9	8·1	1	6·86	2	13·72
5·6	1	20·64	3	17·28	8·2	1	6·48	2	12·97
5·7	1	19·85	3	15·71	8·25	1	6·3	2	12·6
5·75	1	19·47	3	14·95	8·3	1	6·12	2	12·24
5·8	1	19·10	3	14·2	8·4	1	5·76	2	11·52
5·9	1	18·37	3	12·74	8·5	1	5·41	2	10·82
6·	1	17·66	3	11·33	8·6	1	5·06	2	10·13
6·1	1	16·98	3	9·96	8·7	1	4·73	2	9·47
6·2	1	16·32	3	8·64	8·75	1	4·57	2	9·14
6·25	1	16·	3	8·	8·8	1	4·4	2	8·81
6·3	1	15·68	3	7·36	8·9	1	4·08	2	8·17
6·4	1	15·06	3	6·12	9·	1	3·77	2	7·55
6·5	1	14·46	3	4·92	9·1	1	3·47	2	6·94
6·6	1	13·87	3	3·75	9·2	1	3·17	2	6·34
6·7	1	13·31	3	2·62	9·25	1	3·02	2	6·05
6·75	1	13·03	3	2·07	9·3	1	2·88	2	5·76
6·8	1	12·76	3	1·52	9·4	1	2·59	2	5·19
6·9	1	12·23	3	0·46	9·5	1	2·31	2	4·63
7·	1	11·71	2	23·42	9·6	1	2·04	2	4·08
7·1	1	11·21	2	22·42	9·7	1	1·77	2	3·54
7·2	1	10·72	2	21·44	9·75	1	1·64	2	3·28
7·25	1	10·48	2	20·96	9·8	1	1·51	2	3·02
7·3	1	10·24	2	20·49	9·9	1	1·25	2	2·5
7·4	1	9·78	2	19·56	10·	1	1·	2	2·
7·5	1	9·33	2	18·66					

## III.—Continued.

## WRAP TABLE FOR ROVING 30 AND 60 YARDS,

And from 5 to 15 Hanks.

Hank	30 Yards		60 Yards		Hank	30 Yards		60 Yards	
	Dwts.	Grains	Dwts.	Grains		Dwts.	Grains	Dwts.	Grains
10·1	1	0·75	2	1·5	12·6	...	19·84	1	15·68
10·2	1	0·5	2	1·01	12·7	...	19·68	1	15·37
10·25	1	0·39	2	0·78	12·75	...	19·6	1	15·21
10·3	1	0·27	2	0·54	12·8	...	19·53	1	15·06
10·4	1	0·03	2	0·07	12·9	...	19·37	1	14·75
10·5	...	23·8	1	23·61	13·	...	19·23	1	14·46
10·6	...	23·58	1	23·16	13·1	...	19·08	1	14·16
10·7	...	23·36	1	22·72	13·2	...	18·93	1	13·87
10·75	...	23·25	1	22·51	13·25	...	18·86	1	13·73
10·8	...	23·14	1	22·29	13·3	...	18·79	1	13·59
10·9	...	22·93	1	21·87	13·4	...	18·65	1	13·31
11·	...	22·72	1	21·45	13·5	...	18·51	1	13·03
11·1	...	22·52	1	21·04	13·6	...	18·38	1	12·76
11·2	...	22·32	1	20·64	13·7	...	18·24	1	12·49
11·25	...	22·22	1	20·44	13·75	...	18·18	1	12·36
11·3	...	22·12	1	20·24	13·8	...	18·11	1	12·23
11·4	...	21·92	1	19·85	13·9	...	17·98	1	11·97
11·5	...	21·73	1	19·47	14·	...	17·85	1	11·71
11·6	...	21·55	1	19·1	14·1	...	17·73	1	11·46
11·7	...	21·36	1	18·73	14·2	...	17·6	1	11·21
11·75	...	21·27	1	18·55	14·25	...	17·54	1	11·08
11·8	...	21·18	1	18·37	14·3	...	17·48	1	10·96
11·9	...	21·	1	18·01	14·4	...	17·36	1	10·72
12·	...	20·83	1	17·66	14·5	...	17·24	1	10·48
12·1	...	20·66	1	17·32	14·6	...	17·12	1	10·24
12·2	...	20·49	1	16·98	14·7	...	17·	1	10·01
12·25	...	20·4	1	16·81	14·75	...	16·94	1	9·89
12·3	...	20·32	1	16·65	14·8	...	16·89	1	9·78
12·4	...	20·16	1	16·31	14·9	...	16·77	1	9·55
12·5	...	20·	1	16·	15·0	...	16·66	1	9·33

**RING SPINNING:****RING FRAME.**

**Function.**—Draws out the rove and spins the same into yarns on the continuous system. The yarn made is usually spun upon bobbins or paper tubes.

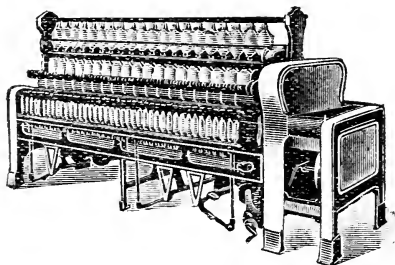

**Feeding.**—By rove from the roving frames.

**Pulleys.**—12 in. to 15 in. dia.  $\times$   $3\frac{1}{2}$  in. to 4 in. wide.

**Speed—**

Counts at 10's .....	5,000 revs. of spindle.
Counts at 20's .....	7,500-8,000 revs. of spindle.
Counts at 25's .....	8,500-9,000 revs. of spindle.
Counts at 30-40's .....	9,500-10,000 revs. of spindle.
Counts at 50-60's .....	9,000 revs. of spindle.
60's Egyptian—	about 8,500.

**Production—**

Counts 10's.....	55 hanks per spindle.
Counts 20's.....	50 hanks per spindle.
Counts 30's.....	45 hanks per spindle.
Counts 40's.....	40 hanks per spindle.
Counts 50's.....	35 hanks per spindle.

**Hank Rovings Suitable for Various Counts—**

Counts 16-18's .....	from 3 hank roving.
Counts 20-24's .....	from $3\frac{1}{2}$ - $3\frac{3}{4}$ hank roving.
Counts 26-28's .....	from $3\frac{3}{4}$ -4 hank roving.
Counts 32's .....	from $4\frac{1}{2}$ hank roving.
Counts 36-44's .....	from 5-6 hank roving.

## Top and Bottom Rollers suitable for Different Kinds of Cotton.

Cottons	Bottom Rollers			Top Rollers			Remarks
	1	2	3	1	2	3	
Indian and Low American	$\frac{7}{8}$	$\frac{3}{4}$	$\frac{7}{8}$	$\frac{11}{16}$ $\frac{11}{16}$ $\frac{11}{16}$	$\frac{3}{4}$ $\frac{11}{16}$	$\frac{13}{4}$ 1	2 and 3 polished, 1 covered. 1 and 2 covered, 3 polished.
Mid. America	1	$\frac{7}{8}$	1	$\frac{7}{8}$ $\frac{13}{16}$ $\frac{3}{4}$	$\frac{7}{8}$ $\frac{13}{16}$ $\frac{7}{8}$	$\frac{7}{8}$ 1 $\frac{13}{4}$	All covered. 1 and 2 covered, 3 polished. 1 covered, 2 and 3 polished.
Egyptian and Sea Island	$\frac{1\frac{1}{16}}$ $\frac{1\frac{1}{16}}$ $\frac{1\frac{1}{16}}$	$\frac{7}{8}$ $\frac{3}{4}$ 1	1 $\frac{1\frac{1}{16}}$ $\frac{1\frac{1}{16}}$	$\frac{13}{16}$ $\frac{7}{8}$ 1	$\frac{13}{16}$ $\frac{7}{8}$ $\frac{7}{8}$	$\frac{13}{4}$ $\frac{13}{4}$ 2	1 and 2 covered, 3 polished. 1 and 2 covered, 3 polished. 1 covered, 2 and 3 polished.

**Draft.**—When single roving is put up at the creel, the draft should not be more than 7 to 7.5, if good results are desired, and for double roving not more than 8 to 8.5.

**Floor Space.**—Width, 3 ft. Length, according to number of spindles in frame.

**Rule to Ascertain Length.**—Half the number of spindles in frame  $\times$  space or gauge between spindles. Add 2 ft. 6 in. for gearing and width of driving pulley.

**Power.**—A frame containing 344 spindles, spinning 28's counts, with 4/0's traveller:—Spindles only, 1.89 I.H.P., about 55 per cent. Spindles and rollers only, 2.19 I.H.P., about 64 per cent. With bobbins empty, 2.98 I.H.P., about 88 per cent. With bobbins full, 3.28 I.H.P., about 97 per cent. Remaining 3 per cent. absorbed by driving traveller.

## H.P. for Ring Frames from actual tests:—

Counts	Gauges	Spindle revs. per minute	Spindles per I.H.P.
36's	$\frac{25}{8}$ in.	8,500	103
32's	$\frac{23}{4}$ in.	8,600	100
24's	$\frac{23}{4}$ in.	9,200	90
20's	$\frac{23}{4}$ in.	9,000	60
9's	$\frac{23}{4}$ in.	6,600	77
On Tubes			
36's	$\frac{21}{2}$ in.	9,300	130

**Another Test.**—In a ring spinning frame, the average of four carefully-conducted tests shows that about 81 per cent. of the power is taken up by the tin rollers and



bands, lift motion, rollers and spindles, while about 19 per cent. is required for drawing out the roving by the rollers, friction of the traveller on the ring, of the yarn through the traveller, and overcoming the air resistance.

**Spindle Wharves.**—1 in. dia. for low counts,  $\frac{7}{8}$  in. dia. for twist, and  $\frac{3}{4}$  in. dia. for weft counts.

**Lift.**—5 in., but for low counts 6 to 7 in.

**Speed Variation.**—Speed variation in ring frames may be utilised to reduce those tensions on the yarn which are excessive and to bring others which are too small up to a normal value. The speed may be regulated so as to equalise the tensions when spinning on all diameters of the bobbin or to the variable shapes of the ballooning, or it may be made to act on both at the same time.

This equalisation of tension may be aimed at either between the front roller and guide eye or between the traveller and the bobbin, according as to whether more importance is attached to an evenly spun yarn with few breakages or to thoroughly uniform winding of the bobbin. In either case, the application of speed variation increases the output of a frame, and at the same time maintains the quality of the yarn.

**Methods.**—This variation of speed may be attained in different ways. For instance, in belt-driven frames cone drums may be used or, in lieu of these, expanding pulleys either for belt or rope driving. When the frames are driven electrically by separate motors, a motor of special design and construction is used, which drives the tin roller. The arrangement, which is protected by letters patent, consists in employing an automatic gear in conjunction with the motor. This gear comprises a cam driven by a chain from the heart shaft of the frame. The cam revolves at the same rate as the heart (consequently making one revolution for every up and down motion of the ring rail), and operates a lifting lever. The other end of this lifting lever is connected to the controlling handle of the motor by a steel wire. As the heart revolves, it drives the cam, which lifts the lever up and down, and so varies the speed of the motor, and therefore that of the tin roller shaft.

The speed of the frame is thus controlled in such a manner as to run much quicker when spinning on to the shoulder of the cop or bobbin than on to the small diameter. The tension on the yarn is, as a result, constantly uniform from the nip of the draught rollers. The range of variation in the speed is about 1 in 5.

TRAVELLERS AND RINGS.



Owing to the many conditions that affect Ring Spinning, such as the amount of twist put into the yarn, the draft, the humidity, etc., it is not possible to state the exact size of traveller to be used for any particular counts. The sizes given in the following tables must therefore be taken as approximate only, but will serve as a guide to users:—

Rings.

Double Roving Sea Islands Cotton...		1½ in. dia.
"    Combed Egyptian " ...		1½ " "
"    Carded " " ...	1½ in. to	1½ " "
"    Combed American " ...	1½ in. to	1½ " "
Single Roving Carded American " ...	24's counts	1½ " "
"    "    "    " ...	34's " "	1½ " "
"    "    "    " above	34's " "	1½ " "
"    Indian Cotton .....	20's " "	1½ " "
"    "    "    " .....	30's " "	1½ " "

Travellers.

To SPIN *Egyptian* COTTON.

Rings, 1½ in. dia. Spindles making 10,000 revolutions per min. Particulars:—

Combed.		Carded		Combed.		Carded.	
Cts.	Traveller.	Cts.	Traveller.	Cts.	Traveller.	Cts.	Traveller.
50	8/0 or 7/0	20	5 or 6	76	16/0 or 15/0	46	9/0 or 8/0
52	9/0 or 8/0	22	4 or 5	78	16/0 or 15/0	48	10/0 or 9/0
54	10/0 or 9/0	24	3 or 4	80	17/0 or 16/0	50	12/0 or 11/0
56	11/0 or 10/0	26	2 or 3	82	17/0 or 16/0	52	13/0 or 12/0
58	12/0 or 11/0	28	1 or 2	84	17/0 or 16/0	54	14/0 or 13/0
60	13/0 or 12/0	30	1/0 or 1	86	18/0 or 17/0	56	14/0 or 13/0
62	13/0 or 12/0	32	2/0 or 1/0	88	18/0 or 17/0	58	15/0 or 14/0
64	13/0 or 12/0	34	3/0 or 2/0	90	19/0 or 18/0	60	16/0 or 15/0
66	14/0 or 13/0	36	4/0 or 3/0	92	19/0 or 18/0	62	17/0 or 16/0
68	14/0 or 13/0	38	5/0 or 4/0	94	19/0 or 18/0	64	17/0 or 16/0
70	15/0 or 14/0	40	6/0 or 5/0	96	20/0 or 19/0	66	18/0 or 17/0
72	15/0 or 14/0	42	7/0 or 6/0	98	20/0 or 19/0	68	19/0 or 18/0
74	15/0 or 14/0	44	8/0 or 7/0	100	20/0 or 19/0	70	20/0 or 19/0

When the speed of the spindles is slower than that given above, heavier travellers must be used. Sea Islands cotton requires travellers five to six grades heavier.

To SPIN *American* COTTON.

Rings,  $1\frac{1}{2}$  to  $1\frac{3}{4}$  in. dia. Spindles making 7,500 revs. per min. Standard twist in yarn.

Counts of Yarn.	Nos. of Travellers.	Counts of Yarn.	Nos. of Travellers.	Counts of Yarn.	Nos. of Travellers.
4	16 or 14	22	3 or 2	37	5/0 or 6/0
6	14 or 12	23	3 or 2	38	6/0 or 7/0
8	12 or 10	24	2 or 1	39	6/0 or 7/0
10	9 or 8	25	2 or 1	40	7/0 or 8/0
11	9 or 8	26	1 or 1/0	41	7/0 or 8/0
12	8 or 7	27	1 or 1/0	42	8/0 or 9/0
13	8 or 7	28	1/0 or 2/0	43	8/0 or 9/0
14	7 or 6	29	1/0 or 2/0	44	9/0 or 10/0
15	7 or 6	30	2/0 or 3/0	45	9/0 or 10/0
16	6 or 5	31	2/0 or 3/0	46	10/0 or 11/0
17	6 or 5	32	3/0 or 4/0	47	10/0 or 11/0
18	5 or 4	33	3/0 or 4/0	48	11/0 or 12/0
19	5 or 4	34	4/0 or 5/0	49	11/0 or 12/0
20	4 or 3	35	4/0 or 5/0	50	12/0 or 13/0
21	4 or 3	36	5/0 or 6/0		

To SPIN *Brazilian* COTTON.

Rings,  $1\frac{3}{8}$  in. dia., weft turns. Spindles, 6,500 revs. per min., 5 in. lift, usual draft.

Counts.	Traveller	Counts.	Traveller.
9	11	28	1
12	10	32	3/0
20	4	40	6/0
24	2		

Rings,  $1\frac{3}{4}$  in. dia., twist turns. Spindles making 7,500 revs. per min.; 6 in. lift, usual draft.

Counts.	Traveller.	Counts.	Traveller.
16	5	28	1/0
20	3	32	3/0
24	2	36	5/0

### Useful Hints.

Roller stands should be at an angle of about 25 deg.

Ordinary "Rabbeth" spindles are not suited for speeds above 6,000 revs. per min. Above this speed, use flexible spindles.

Oil-cups to the spindles are an advantage. There is no stopping when oiling, nor waste, and oiling is only necessary about every 12 to 14 weeks.

Variable traverse motions effect a great saving in leathers. A motion to attain its object successfully should so vary the traverse that the path of the guide never starts and finishes at the same place until the cycle of movements has been completed, while the repeat movements should occur as seldom as possible.

Metallic guides should be used on the frames, to ensure concentricity of the thread wires with the spindles and rings. They not only cause better yarn to be spun, but prolong the life of the rings and travellers.

Double tin rollers, 10 in. dia., are mostly used on ring frames, and when positively driven they ensure a uniform speed of the spindle and prolong the life of the driving-bands.

Separators or anti-ballooning motions economise in spindle space and prevent waste. They also facilitate greater production of yarn, and allow the use of lighter travellers.

When the yarn spun has to be rewound, it is a common practice to build the cops with a straight or long lift, as the yarn comes off more freely, and a greater speed can be applied to the reels or swifts.

In spinning fine counts on the ring frame, the output per spindle can be increased by taking advantage of the additional speed admissible after the formation of the cop or bobbin bottom. This is done by applying a two-speed drive frame. The first or slow speed (which is equivalent to the normal speed of a single-driven frame) is used until the cop bottom is formed. The second, or quick speed, comes into action for the remaining portion of the spinning.

**Oiling and Cleaning.**—The front, bottom, and top rollers should be oiled every two days; the middle and back rollers, along with the tin roller bearings, once a week. [daily.

The fluff from the top roller pivots should be removed

The fluted rollers should be thoroughly cleaned at least every nine or ten weeks.

The thread-guides should be examined periodically, and (if necessary) adjusted concentrically with the rings and spindles.

The underclearers should be cleared four times a day and the top clearers once a day.

When spinning *waste* on the ring frame, the creels and bobbins are dispensed with, and an arrangement is provided for taking-in condenser bobbins or cheeses directly from the carding engine.

### Rules for Changes of Ring Frames.

- To find Constant for Twist—  

$$\frac{\text{Dia. Tin Roller} \times \text{Carrier Wheel} \times \text{Front Roller Wheel}}{\text{Wheel on Tin Roller} \times \text{circum. Ft. Roller} \times \text{dia. of Wharve}} \cdot 5\%$$
- To find Star or Builder Wheel—  

$$\frac{\text{Wheel on} \times \text{Counts Wanted}}{\text{Counts Spun}}$$
- To find Twist—  

$$\frac{\text{Constant}}{\text{Twist Wheel}}$$
- To find Twist Wheel—  

$$\frac{\text{Constant}}{\text{Twist required}}$$
- To find Draft—  

$$\frac{\text{Constant}}{\text{Draft Wheel}} = \text{Draft}$$
- To find Front Roller Speed—  

$$\frac{\text{T.R.} \times \text{T.R.W.} \times \text{T.W.}}{100 \times \text{F.R.W.}}$$
- To find Draft Wheel—  

$$\frac{\text{Constant}}{\text{Draft required.}}$$
- To find Spindle Speed—  

$$\frac{\text{Line Shaft} \times \text{dia. of Pulley} \times \text{dia. of T.R.}}{\text{Dia. Frame Pulley} \times \text{dia. of Wharve}} \text{ less } 10\% \text{ for slipping}$$
- To find Constant for Draft—  

$$\frac{\text{Counts} \times \text{Back Roller}}{\text{F.R.W.}}$$
- To find Twist—  

$$\sqrt[2]{\text{Counts} \times \text{Constant}}$$
- Constant— 3·5, 3·75, 4·0, 5·5
- English Counts— French Counts  $\times$  1·18
- French Counts—  

$$\frac{\text{English Counts}}{1·18}$$

### Setting Thread-Guides.

The diagrams on the following page have been prepared by Mr. J. E. Tytler, of Manchester. They show very clearly the effects of correct and incorrect setting of thread guides in relation to the spindles and rings on ring spinning frames:—

INCORRECT SETTING OF THREAD WIRE. THE TENSION BETWEEN ROLLER AND THREAD WIRE EYE VARIES NOT ONLY ACCORDING TO DIAMETER OF BOBBIN AT DIFFERENT PARTS OF THE LIFT, BUT AT EVERY REVOLUTION OF THE TRAVELLER.

CORRECT SETTING OF THREAD WIRE. THE TENSION BETWEEN FRONT ROLLER AND THREAD WIRE EYE VARIES ONLY ACCORDING TO DIAMETER OF BOBBIN AT DIFFERENT PARTS OF THE LIFT.

UNEQUAL ANGLES OF YARN AT ALL PARTS OF THE RING.

EQUAL ANGLES OF YARN AT ALL PARTS OF THE RING.

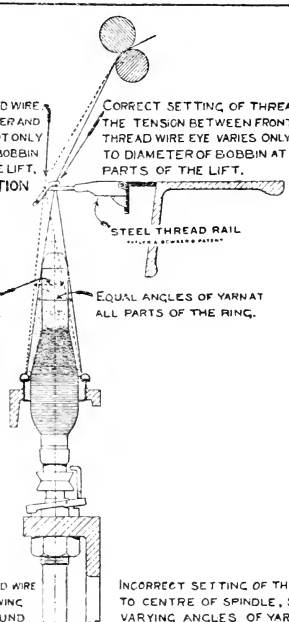

CORRECT SETTING OF THREAD WIRE TO CENTRE OF SPINDLE, SHOWING EQUAL ANGLES OF YARN ROUND CIRCUMFERENCE OF BOBBIN MAINTAINING EQUAL TENSION AND BALLOONING, ALSO EQUAL WEAR OF RING.

INCORRECT SETTING OF THREAD WIRE TO CENTRE OF SPINDLE, SHOWING VARYING ANGLES OF YARN ROUND CIRCUMFERENCE OF BOBBIN CAUSING UNEQUAL TENSION AND BALLOONING, ALSO UNEQUAL WEAR OF RING.

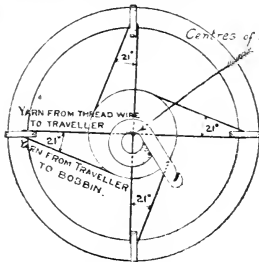

CORRECT SETTING.

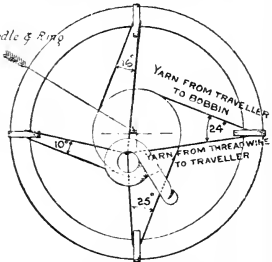

INCORRECT SETTING.

### RING FRAME OIL MEASURER.

**Function.**—Measures and supplies oil to ring frame spindle sockets.

**Description.**—Is usually constructed to hold about 1 quart of oil, and is provided with a vertical force pump, the piston of which is pressed down by the thumb of the operator. An adjusting screw is fixed under the thumb-piece, by means of which the amount of each discharge can be altered. When it is fitted with a sight-feed to the spout, the user can see at a glance that the oiler is doing its work properly.



### OIL EXTRACTOR.

**Function.**—Extracts the old spent oil from the bearings of ring frame spindles, and cleans them out before reoiling.

**Description.**—Is a simple form of pump, the piston of which draws the oil into a chamber. At intervals this is emptied by taking out a screw under the pump handle.



## MULE SPINNING:

### THE SELF-ACTING MULE.

**Function.**—Spins intermittently. The yarn made is either spun on the bare spindle, or upon short paper tubes when such are required to form a base for the cop bottom. Will spin any counts of yarn required, and is specially adapted for yarns in which elasticity and "cover" are essentials.

**Feeding.**—Receives the cotton from the Roving Frame, or from the Fine Roving Frame when the latter is used in the preparation.

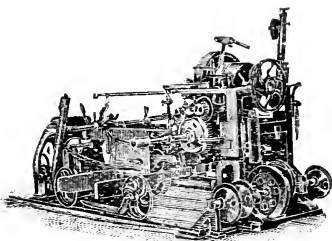

American cotton yarn, up to (say) 50's or 60's counts, is sometimes produced from single rovings—that is, one roving bobbin to each mule spindle. Egyptian and better-class yarns are always spun from double roving or two bobbins to each spindle.

The roving bobbins are placed in creels, three or four bobbins in height and in single or double rows, according to the class of yarn being spun.

Single roving means 1 bobbin to a spindle.

Double do. 2 bobbins do.

The rove from these bobbins passes over a rod, through guides, and between three pairs of draft rollers, where it is drawn out in the usual way. From the rollers to

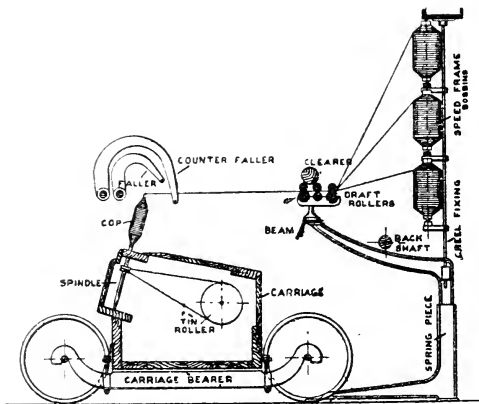

the spindles the drawn-out rove passes through faller wires. The spindles are slightly inclined towards the rollers, the angle varying according to the counts of yarn spun, and is least for coarse counts. They are mounted in a movable carriage, and driven from tin drums. When the rollers begin to deliver the rove, the carriage commences to travel outwards, and the spindles, by revolving at a high speed, put the twist in the yarn. These three



operations take place simultaneously. When the carriage has completed its outward run, backing-off takes place—that is, the spindles are stopped and at once reversed. While this is taking place the counter faller wire descends and the winding rises, and in so doing puts a little tension on the yarn and guides it on to the cop. As soon as the backing-off is completed, the carriage commences its inward run; the spindles are again reversed to their former direction and wind the yarn on to the cop, through the medium of the faller wires, which serve as guides. The carriage having completed its inward journey, the winding stops and the fallers resume their original positions and the cycle of operations again commences.

**Weighting.**—The weighting of the top rollers varies. For coarse counts all three rows are weighted, but for fine counts only the front row are weighted while the middle and back are self-weighted.

**Pulleys.**—16 in. to 18 in. dia.  $\times$   $5\frac{1}{4}$  in. wide.

Belt from line shaft to countershaft usually 6 in. wide.

Belt from countershaft to mule headstock 5 in. wide.

**Speeds.**—Pulleys, 650 to 750 revs. per min. for low counts; 850 to 900 revs. per min. for medium and fine.

### Speed of Spindles and Stretch for Various Counts:—

Counts	Revs. of Spindles	Stretch	Draws per min.
6's to 12's	5,000 to 8,000	66 in.	$5\frac{1}{2}$ to $5\frac{3}{4}$
14's to 16's	8,500	66 in.	$4\frac{3}{4}$ to 5
18's to 24's	9,000 to 9,500	66 in.-64 in.	$4\frac{3}{4}$ to 5
30's to 50's	10,000 to 11,000	64 in.	4 to $4\frac{1}{2}$
60's to 80's	9,000	64 in.	3 to $3\frac{1}{2}$
90's to 100's	8,000 to 8,500	62 in.	$2\frac{1}{2}$ to $2\frac{3}{4}$
120's	7,500 to 8,000	60 in.	$2\frac{1}{4}$
150's	{ 7,200 double speed 4,800 single speed }	56 in.	2
180's	{ 6,800 double speed 4,500 single speed }		
200's	{ 6,700 double speed 4,250 single speed }	52 in.	1.7
250's	{ 6,250 double speed 3,500 single speed }		
300's	{ 6,000 double speed 2,700 single speed }	48 in.	1

**Production (Approximate):—**

Counts	Hanks per week	Counts	Hanks per week
16-20	32	70T double roving	21 $\frac{3}{4}$ -22
24-32	32-33	80T	20 $\frac{3}{4}$
34T	31	90T	19
34 W	31 $\frac{3}{4}$	100W	19 $\frac{3}{4}$
42T	28 $\frac{1}{4}$	110W	18 $\frac{1}{2}$
42W	28 $\frac{3}{4}$ -29	120W	17 $\frac{1}{2}$
60T double roving	23 $\frac{1}{4}$	140T	15

**Rule for Production:—**

$$\frac{\text{No. of draws} \times \text{Length of stretch in inches} \times \text{Working hours per week} \times 60 \text{ minutes}}{840 \text{ yards} \times 36 \text{ inches (or 30,240 inches)}} = \frac{\text{Hanks per week}}{\text{per } \div \text{ Counts}} = \text{lb}$$

*Note.*—Allowance must be made for cleaning, doffing, etc.—5 per cent. to 7 $\frac{1}{2}$  per cent., according to counts of yarn and the number of doffings, etc.

**Floor Space.**—Width (allowing 64 inches stretch from back to back of headstock of a pair of mules), 20 ft. over all.

**Rule to Ascertain Length of Mule with rim pulley at back.**—Gauge of spindles  $\times$  number of spindles in frame. Add space taken up by headstock gearing, which is usually 5 ft. 6 in.

**Power—**

For Indian and Low American.....110 spindles to 1 H.P.  
 For Medium Counts.....120       "       "  
 For Fine Counts.....125 to 130   "       "

**Standard Turns per Inch—**

American Twist,  $\sqrt{\text{Counts} \times 3.75}$ .  
 American Weft,  $\sqrt{\text{Counts} \times 3.25}$ .  
 Egyptian Twist,  $\sqrt{\text{Counts} \times 3.606}$ .  
 Egyptian Weft,  $\sqrt{\text{Counts} \times 3.185}$ .  
 Doubling Weft,  $\sqrt{\text{Counts} \times 2.8}$ .

### Spindle Lengths, Setting, etc., for Different Counts:—

	Length of spindle	Length out of Bolster	Diameter of Wharve	Diameter of Tin Roller
For Low Counts Twist ...	18 in.	9 in.	$\frac{7}{8}$ to 1 in.	6 in.
„ Medium Counts Weft	$13\frac{1}{2}$ in.	$6\frac{1}{2}$ in.	$\frac{7}{8}$ in.	5 in.
„ ” ” ”	$15\frac{1}{2}$ in.	$7\frac{1}{2}$ in.	$\frac{7}{8}$ in.	5 in.
„ Ordinary Twist.....	$17\frac{1}{2}$ in.	$8\frac{3}{4}$ in.	$\frac{7}{8}$ in.	6 in.

Spindles usually  $13\frac{1}{2}$  inches, but by using  $15\frac{1}{2}$  in. spindles for the weft, the spinner can spin what are known as “bastard cops.” These are often required for doubling purposes.

In setting mule spindles, see that the driving bands rest upon the lower inclined flanges of the wharves, thereby preventing the spindles from rising in their bearings. *Rule to be observed:—* The centre of the wharve (taken from the level of the spindle) should point  $\frac{1}{2}$  inch below the centre of the tin roller shaft, as shown in diagram. Care should be exercised in getting the correct tension on the driving bands. It is faulty to have the bands too slack or too tight.

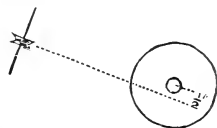

#### Bevel of Spindles for Different Counts.

Counts	Bevel with $17\frac{1}{2}$ in. Spindle	Distance from top of bottom roller to Spindle top B
20's-40's	$3\frac{3}{4}$ in.	$2\frac{1}{2}$ in.
40's-60's	$4$ in.	$2\frac{5}{8}$ in.
60's-80's	$4\frac{3}{4}$ in.	$2\frac{3}{4}$ in.
80's-120's	$5\frac{1}{2}$ in.	$2\frac{7}{8}$ in.



For doubling weft  $\frac{1}{4}$  in. more.

Pin cops made as doubling weft in proportion to the  $17\frac{1}{2}$  in. spindle.

**Rollers.**—For low counts the rollers are sometimes made 4 threads per boss. Medium counts, American, 3 threads per boss. Fine counts, for good results, should have single boss rollers, but in some districts 2 threads per boss are worked.

For mules (say) over 140 feet long, it is advisable to have the rollers driven in the middle of each side—

this being to overcome the tension and reduce as much as possible the strain in the necks and squares. Also long mules should be provided with middle drawing-out bands and extra taking-in scrolls, to ensure greater steadiness in the carriage.

**Diameter of Draft Rollers for Different Cottons.**

Cottons	Bottom Rollers			Top Rollers
	1.	2.	3.	
Indian and low American ...	$\frac{7}{8}$ ,	$\frac{3}{4}$ ,	$\frac{7}{8}$ in. dia.	All $\frac{3}{4}$ in. dia.
American .....	1,	$\frac{1}{8}$ ,	1 in. dia.	All $\frac{3}{4}$ in. dia.
Egyptian .....	$1\frac{1}{16}$ ,	$\frac{7}{8}$ ,	$1\frac{1}{16}$ in. dia.	All $1\frac{1}{16}$ in. dia., or $1\frac{1}{16}$ , $\frac{15}{16}$ , 2 in. dia.
Sea Islands ...	$1\frac{1}{8}$ ,	1,	$1\frac{1}{8}$ in. dia.	All 1 in. dia., or $1\frac{1}{16}$ , $\frac{15}{16}$ , $2\frac{1}{8}$ in. dia.

**Draws and Revolutions of Top Rollers.**

Revs. per min. of Front Rollers (continuous working) in relation to the number of draws per min. for various diameters of rollers.

Draws	Sec. per Draw	$1\frac{1}{8}$ in.	$1\frac{1}{16}$ in.	1 in.	$\frac{7}{8}$ in.	$\frac{3}{4}$ in.
6	10	197.5	209	222.3	237.1	253.9
5	10.21	190	201.17	213.7	228	244.2
5	10.43	183.1	193.8	206	219.7	235.4
5	10.66	176.2	186.5	198.2	211.4	226.5
5	10.9	169.5	179.4	190.6	203.4	218
5	11.16	163.07	172.6	183.4	195.68	209.66
5	11.42	156.1	165.2	175.6	187.3	200.7
5	11.7	150.7	159.5	169.5	180.8	193.6
5	12	144.8	153.3	162.9	173.7	186.1
4	12.3	139.1	147.2	156.4	166.9	178.8
4	12.63	133.6	141.4	150.3	160.3	171.77
4	12.95	128.21	135.7	144.2	153.8	164.8
4	13.3	123	130.3	136.3	147.6	158
4	13.7	118	124.8	132.7	141.6	151.7
4	14.1	112.9	119.5	127	135.48	145.15
4	14.5	108.2	114.5	121.7	121.84	139.1
4	15	103.4	109.4	116.3	124.08	132.9
3	15.4	98.8	104.2	111.15	118.56	127.02
3	16	94.4	100.02	106.2	113.28	121.37
3	16.55	90.1	95.4	102.36	108.12	115.84
3	17.14	85.94	90.99	96.68	103.128	110.49
3	17.7	81.8	86.6	92.02	98.16	105.17
3	18.46	77.8	82.35	87.52	93.36	100.03
3	19.2	73.9	78.24	83.13	88.68	95.01
3	20	70.1	74.2	78.86	84.12	90.13

An allowance of  $4\frac{1}{2}$  secs. is made for the time taken up in backing-off during each draw.

**Hank Rovings for Different Counts.**

American Single Roving	Hank Roving	Egyptian Double Roving	Hank Roving
Counts 16 to 18	$2\frac{1}{2}$ - $2\frac{3}{4}$	Counts 40's to 50's	9-9 $\frac{1}{2}$
„ 20 to 26	$3$ - $3\frac{1}{2}$	„ 60's	11-11 $\frac{1}{4}$
„ 28 to 32	$3\frac{3}{4}$ - $4\frac{1}{4}$	„ 70's	12-13
„ 36 to 44	$4\frac{1}{2}$ - $5\frac{1}{4}$	„ 80's	14-14 $\frac{1}{2}$
50's w	5	„ 90's	15-16
60's w	$5\frac{1}{2}$	„ 100's	16-17

**Calculation by Slide Rule.**

A slide rule is available by means of which these calculations may be readily made. It is a combination of three slides, the whole making one block  $14\frac{1}{4}$  inches long. The top portion of the latter gives the number of spindles in a mule, from 500 to 2,000. The upper slide denotes on its top edge the time taken by three "draws" of the mule-carriage, and on the bottom edge are the lengths of the stretches in inches. The middle slide gives the counts of yarn spun from 10's to 150's, and the bottom one the weight of yarn in pounds per week of 55 hours. The scale on the lower part of the fixed portion of the rule is used for making allowances for, or ascertaining, the losses due to doffing, broken ends, stoppages, etc.

To work the rule, all that is necessary is to start at the top and move the slide so that the time of three draws comes under the number of spindles; move the middle slide so that the number of counts comes under the figure denoting the stretch; move the bottom slide till the "waste" arrow-marks show the estimated loss to be about right, and the middle-slide arrow will point to the output on the top of the lowest slide. If the waste arrow be set at "No loss," the theoretical output of the spindles is given.

In order to ascertain the actual loss on certain pairs of mules where the output is known, it is necessary to set the top and middle slides as directed above, then move the bottom slide until the actual output comes under one of the middle-slide arrows, whereupon the waste arrow will point to the actual loss.

**Metal Carriages.**

Metal Mule Carriages are recommended as a precaution against fire. Carriages thus constructed are not

only non-flammable, but are also lighter and stronger than wood, more easily cleaned, and not so subject to atmospheric changes. They are also more rigid, and admit of high speeds in the mule.

It is estimated that in the ordinary life-time of a mule carriage constructed of wood, its weight is increased between 50 and 60 per cent. by the absorption of oil.

---

STRAP-FORKS of mules should be moved in a parallel line from one pulley to the other instead of radially. There is then less wear and tear on the driving belt, and a deeper strap-fork can be used.

---

### FINE SPINNING MULE.

In addition to the usual mechanism, all mules designed for spinning fine yarn should be equipped with the following motions:—

**STRETCHING MOTION.**—To impart movement to the carriage on the completion of the outward run, after the rollers are stopped, to give the necessary stretch to the yarn.

**FALLER MOTION.**—To take the strain off the yarn, and to a certain extent to prevent snarls.

**WINDING MOTION.**—To impart increased speed to the spindles just before the inward run of the carriage is completed, so as to wind on any slack yarn and prevent snarls. This motion should be so arranged that it can be made to operate at any distance up to 7 or 8 inches before the completion of the inward run.

**ROLLER DELIVERY MOTION.**—To let out a sufficient amount of rove, and thus relieve the tension when extra twist is put in the yarn on the completion of the outward run of the carriage.

**DOUBLE SPEED.**—To impart increased speed to the spindles when the twisting is taking place in spinning counts about 140's.

**DRAWING-UP MOTION.**—To regulate the speed of the taking-in of the carriage at any period of the draw and any part of the cop. Applicable when spinning above 120's counts.

Double roving usually produces 10 per cent. stronger yarn than single roving, and the yarn spun is more even.

### MULES FOR HOSIERY YARN.

Hosiery yarns are produced on the ordinary cotton mule, and are very soft-spun, as in fine cotton spinning. The conditions under which they are made vary considerably, so that no standard of yarn can be arrived at.

**AN EXAMPLE.**—Mules to spin 5's to 45's with a spindle speed of 3,000 to 7,500 revs. per min. have a hank roving 1.5 to 7, and the turns per inch from 6 to 20.

**Spindles.**—17½ in. to 18 in. long and 8¼ in. to 9 in. out of bolster.

**Speeds.**—Rim shaft, 700 to 750 revs. per min.

Spindles, 3,000 to 8,000 revs. per min.

### COP TUBING APPARATUS.

**Function.**—Supplies the spindles of mules and twiners with paper tubes to form a base for the spun cops. Two (sometimes three) tubers are used for each pair of mules.

**Description.**—Each apparatus is provided with from 20 to 25 delivery outlets, according to length of mule; the supply magazine is capable of holding 500 tubes at one charge. The outlets correspond in number to the number of chambers in one row of the magazine, and are secured to a plate or door, which at the time of filling is turned back on its hinges. As each row of pockets is filled, the chamber is moved round to bring another row opposite the openings by means of a slide-and-clasp arrangement.

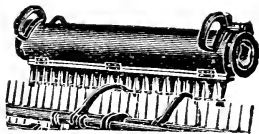

In using the apparatus, the operator places it over the spindles, and, by moving the slide mentioned, liberates the first row of tubes, which fall simultaneously on to the spindles. The operation is repeated over the remaining spindles.

### COP TUBE SETTER.

**Function.**—Presses the tubes down on mule spindles to the required distance, after being dropped thereon by a cop tubing apparatus.



**Description.**—Consists of a beaded plate, with notches spaced therein to correspond with the gauge of the spindles. Is adjusted by two stop-screws with lock-nuts, which come into contact with the spindle-rail.

### SPINDLE FOOTSTEP PROTECTOR.

**Function.**—Protects the footsteps of mule spindles from dirt and fluff, and the oil from running down the spindle-rail at the time of oiling.

**Description.**—Is formed in one continuous rail, so as to cover the line on which the spindle footsteps are fixed, each individual protector being enclosed within the rail.

## DRAFTING :

### DRAFT IN COTTON MACHINES.

Draft in Cotton Preparing and Spinning Machines is measured by the relative lengths of cotton fed and delivered in a given time.

The amount of draft in a machine may be ascertained by dividing the surface speed of the delivery roller by that of the feed roller. Thus, in a scutcher, if the surface-speed of the feed-roller be  $56\frac{1}{2}$  inches per minute, and that of the lap-roller 249 inches per minute, the draft is  $249 \div 56.5 = 4.4$ .

As in all cotton machines there is a direct connection between the feed-roller and the delivery-roller (by means of toothed wheels or by means of pulleys), it follows that the relative speeds of these rollers may be obtained. Suppose Fig. 1 to represent a simple machine, A being the feed-roller and B the delivery-roller. On A is a wheel C, of 20 teeth, driving D of 10 teeth on the delivery-roller :—

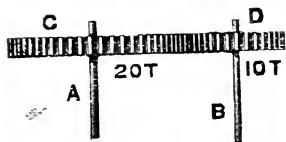

FIG. 1.

The calculation is made by multiplying the revolutions of A by the number of teeth in C, and dividing by the number of teeth in D. Thus,  $1 \times 20 \div 10 = 2$ . If the circumference of A is equal to the circumference of B, the surface speed of B will be twice that of A, and therefore the draft in the machine will be 2.

If A and B are each 2 inches in circumference, the surface speed of B equals  $20 \times 2 \div 10$ . By dividing the surface speed into that of the delivery, the result is—  
 $20 \times 2 \text{ in.} \div 10 \times 2 = 2 \text{ draft.}$



As the rollers in the machines are sized in diameters, the calculation (so far as draft is concerned) can be made without working out the circumferences. Referring again to Fig. 1. If A is 2 in. diameter, and B 8 in. diameter, the draft will be—

$$\frac{20 \times 8 \text{ in.}}{10 \times 2 \text{ in.}} = 8$$

All draft calculations may be solved on the above basis.

In the following machine the draft would be—

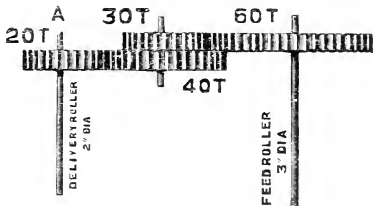

$$\frac{60 \times 40 \times 2 \text{ in.}}{30 \times 20 \times 3 \text{ in.}} = \frac{8}{3} = 2\frac{2}{3} \text{ draft.}$$

FIG. 2.

Or, if the change-wheel A be required to give a draft of  $2\frac{2}{3}$ , substitute the draft for the number of teeth in A, thus:—

$$\frac{60 \times 40 \times 2}{30 \times 2.6 \times 3} = \frac{160}{7.8} = 20 \text{ teeth in A, required.}$$

Fig. 3 represents the principle as applied to a Carding Engine. In this case the draft between the feed-roller and doffer would be—

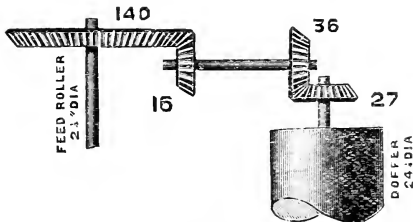

FIG. 3.

$$\frac{140 \times 36 \times 21.75 \text{ in.}}{16 \times 27 \times 2.25 \text{ in.}} = \frac{11.55}{.09} = 128.3 = 128\frac{1}{3} \text{ draft}$$

between feed-roller and doffer.

In a Scutcher of the following particulars—

Feed roller,  $2\frac{1}{4}$  in. diameter.

Wheel on end, 55 teeth.

Gearing with worm wheel pinion, 45 teeth.

Worm wheel, 65 teeth.

Gearing with a single worm on top cone shaft.

Cones on equal diameters.

Bottom cone drum wheel, 24 teeth.

Driving a 48's pinion on side shaft.

On other end of side shaft a 20's bevel.

Gearing with a 30's bevel on bottom cross shaft.

On other end of cross shaft a 13's wheel.

Gearing with a 65's wheel on drop shaft.

Also on drop shaft a 20's pinion for driving lap rollers.

Gearing with a 71's wheel compounded with a 17's wheel.

This latter drives a 30's lap roller wheel on the end of the lap roller.

Lap roller,  $8\frac{3}{4}$  in. diameter—

the calculation would be as under :—

$$\frac{55 \times 65 \times 24 \times 20 \times 13 \times 20 \times 17 \times 8.75 \text{ in.}}{45 \times 1 \times 48 \times 30 \times 65 \times 71 \times 30 \times 2.25 \text{ in.}} = \frac{1701.7}{517.59} = 3.3 \text{ draft of scutcher.}$$

If, in a Scutcher, the weight of feed per yard is 48 oz., and the weight of delivery 12 oz., the draft would be four, if no waste were taken out by the machine. But, as all machines take out waste, it is impossible for the 48 oz. of feed to be drawn out into four yards of 12 oz. each. If, therefore, the Scutcher is taking out 4 per cent. waste, all that can be obtained from 48 oz. is 96 per cent. Calculate accordingly. Thus:—

$$\frac{48 \times 96}{12 \times 100} = \frac{384}{100} = 3.84 \text{ draft.}$$

Or, in a Card, if the lap is 12 oz. per yard, and the sliver 60 grains per yard, with 8 per cent. waste, the draft would be 12 oz., or—

$$\frac{\begin{array}{l} \text{grains} \\ 5250 \times 92 \end{array}}{60 \times 100} = \frac{161}{2} = 80.5 \text{ draft.}$$

This would, of course, be the draft over all, and must not be confused with the draft between feed-roller and doffer in Fig. 3.

This method is certainly much simpler than that first explained, but of necessity it cannot be so accurate, as all the factors in the calculation—that is, weights and amount of waste—are estimates only.

These principles apply to all cotton machines, and may be illustrated by the Mule or Roving Frames as well as by the examples quoted.

---

In altering the draft of preparing and spinning frames the change should not be restricted to the 1st and 2nd rollers for the total, but the difference should be distributed over the 2nd and 3rd, and in the case of drawing frames with four pairs of rollers to the 3rd and 4th.

Assuming that the three drafts in the 1st head of drawing are 1.2, 1.36, and 3.16 respectively, giving a total of 4.82, and it is required to get a total draft of 5.50 at the 2nd head, the following rule is observed:—

Find the ratio of the two total drafts by dividing one by the other. Extract the cube root of the quotient and multiply the three former drafts by the square root thus found; the result will be the three respective drafts to suit the new total. Thus—

Let  $x$  = ratio, then

$$1.12x \times 1.36x \times 3.16x = 4.82x^3,$$

and from this equation results—

$$4.82x^3 = 5.50 \text{ or } x^3 = 5.50 \text{ or } x = \sqrt[3]{5.50}$$

4.82

4.82

By multiplying the three drafts in the 1st head by this value of  $x$ , the product is 5.50 draft in 2nd head.

NOTE.—It should be noticed that when the total draft is decreasing, or the counts are being made coarser, the former three drafts must be divided by the root as found above, and the result will be the same. For frames with three rows of rollers the same rule applies, except that the ratio of two drafts only is taken into account.

By adopting the above rule the finished yarn is stronger and more even; and the breakages are fewer because the ratio of speeds of all the cotton fibres is maintained through each pair of rollers down to the delivery of the rove on the spinning machine, whether mule or ring frame.

## COVERING DRAFT ROLLERS

### MACHINES AND APPLIANCES.

No cotton-spinning mill of to-day can be considered fully equipped that does not possess a complete installation of machinery and appliances for covering and otherwise finishing off the top drawing rollers of preparing and spinning frames. The antiquated method of using primitive tools and appliances is being discarded and machinery of delicate construction now takes its place.

The complete series of machines and appliances used should consist of the following:—

- Cloth Covering Machine.
- Leather Cutting Board.
- Leather Grinding or Equalising Machine.
- Leather Splicing or Bevelling Machine.
- Leather Piecing Press.
- Leather Tube Pulling-on Apparatus.
- Roller-ending Machine.
- Calender for Finishing Rollers.
- Truing and Varnishing Machine.
- Roller Testing Machine.

**CLOTH COVERING MACHINE.**—Takes the cloth in the form of strips of a definite width, passes it through a paste-box, measures and cuts the cloth into lengths and by a rolling action fixes the cut piece into its correct position on the boss of the roller.

**LEATHER CUTTING BOARD.**—Is used when cutting the skins into strips of the correct width. It is provided with adjustable stops by the side of which measuring plates are inserted. A planed straight-edge or bar extends across the board, with the cutting edge close to a slot for the knife to enter. The bar is raised to allow the skins to pass under, then lowered to grip them when the cutting takes place.

**GRINDING OR EQUALISING MACHINE.**—Grinds the leather strip from the flesh side, just sufficiently to equalise its thickness without any undue waste of fibre and strength. The machine is provided with a drum, over which the leather strip is passed. Whilst on the drum the surface is ground by a glass-covered roller. The fibre and dust taken off the leather are removed by a quickly revolving fan.

**SPLICING MACHINE.**—This machine takes the ground leather strips and cuts them into pieces of the required size and at the same time bevels off the edges so as to make a perfect joint when the piecing takes place. The leathers are passed between feed rollers (flesh side up) which, by revolving, give off a predetermined length of strip. The piece is cut off by a knife held in a sliding carriage, which moves across the machine. The knife when cutting, slides on a glass plate to ensure a clean cut of the leather.

**PIECING PRESS.**—Presses the two bevelled edges of the pieces of leather together so as to form a tube or “hot” for drawing over the bosses of the rollers. When the press is provided with a turntable the tubes can be prevented from sticking together after pressing.

**PULLING-ON APPARATUS.**—Draws the tube or “hot” on the roller over the cloth and can be worked vertically or horizontally. The roller to be covered is held in a countersunk stud; and, by means of a series of fine springs joined together, the leather is drawn gently into its place on the roller, and the necessary movement is obtained by turning a handle which operates a pinion and rack.

**ROLLER ENDING MACHINE.**—Is the first machine employed in the finishing process, and is used in turning down the superfluous leather, which projects beyond the surface of the boss. The machine consists of a polished cylinder, which revolves at from 700 to 1,000 revs. per minute.

**CALENDERING MACHINE.**—In this machine the rollers are calendered between hot surface plates and improved in many ways. Not only are flat places, scaly surfaces, and other imperfections removed, but a high polish is imparted to the leather surface.

**TRUING AND VARNISHING MACHINE.**—For use in mills where it is the custom to grind and varnish combing machine and draw frame rollers. It can also be used with advantage for putting into workable condition rollers that are not sufficiently worn to require recovering. The rollers to be ground are carried in spring chucks mounted in ball bearings. The grinder is in the form of a disc covered with emery, and has a traversing movement

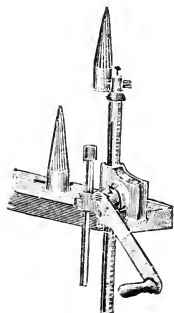

worked by a double-threaded screw. When varnishing, the reversing motion is disconnected and the disc remains stationary at one end of the screw. The varnish is applied thinly by a flat hog-haired brush.

In another type of machine, which is for grinding and truing only, the top roller to be operated upon is fixed in two brackets, made adjustable to admit varying lengths of rollers. One of these has a cross-adjustment, in order that the rollers may be set parallel to each other. There are fast and loose driving pulleys,  $3\frac{1}{2}$  inches in diameter, which run at about 1,400 revolutions per minute. Attached to the fast pulley is one for communicating motion to a pulley on a lower shaft, which again transmits motion to small pulleys for rotating the rollers to be ground.

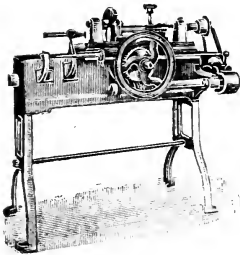

On a reversing shaft is a worm working into a worm-wheel, which gives a longitudinal reciprocating movement to the table by means of a rack and pinion.

The leather covering of the top roller is brought into contact with the grinding disc by a vertical screw; and the feed is applied to the grinding surface by means of a ratchet wheel (connected with the screw), and a catch actuated at each traverse of the table by a slide bar, which is adjustable to any length of roller.

The grinding material for covering the metal disc may be either emery-cloth or glass-cloth, or even paper coated with these substances. Sand paper is also a good grinder, two strips being tightly fastened on the periphery by means of the small plates and screws.

**TESTING APPARATUS.**—This is the last of the series and by its use the surface of the rollers can be tested and any irregularity therein discovered. The apparatus consists of two bars or plates one above the other, and having absolutely parallel surfaces. The upper plate is suspended to rise and fall any distance required by the diameter of the roller. The bottom plate is grooved to receive the roller and keeps it in position for testing. The test is made by allowing the upper plate to fall upon the surface of the roller and by the aid of a strong light at the back: the tester bar will show spaces if any irregularity exists in the covering of the roller.

**Breaking Stresses.**—The accompanying Diagram shows the breaking stresses of the various portions of a roller leather pelt.

Average breaking stress for a whole skin—136 lb.

Average :

346 lb.

169 lb.

108 lb.

174 lb.

166 lb.

72 lb.

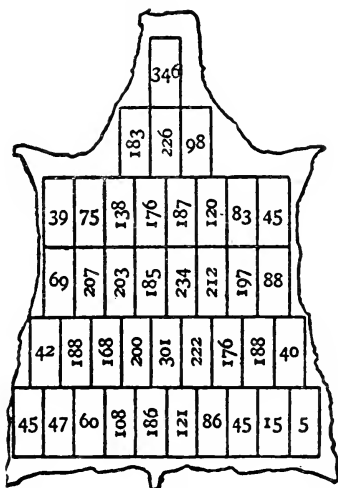

### DURATION OF LEATHER-COVERED ROLLERS.

In a mill spinning, say, 56's counts, and where the rollers are kept in first-class condition, they last the following periods:—

Drawing Frame front rollers .....	3 months.
"    middle and back rollers .....	5 "
Slubbing, Intermediate, and Roving Frame front rollers .....	6 "
Slubbing, Intermediate, and Roving Frame middle and back rollers .....	8 to 9 "
Ring Spinning Frame rollers .....	6 to 8 "
Mule rollers .....	4 to 8 "

The above are approximate and would vary with different counts, quality of cotton, etc. They are, how-

ever, taken from the working of a modern mill using pelts and roller cloth of good quality.

By using the latest variable traverse motions, the above periods may be considerably increased.

In another mill, of 65,000 ring spindles, spinning 30's to 46's twist and 28's to 46's weft—

Slubbing Frames, $\frac{1}{2}$ hank roving .....	11 to 12 months.
Intermediate Frames, 1-2 hank roving	7 to 8 ,,
Roving Frame, 5 hank roving.....	10 ,,
Ring Frame—Twist .....	7 to 8 ,,
„ —Weft .....	6 to 7 ,,

Pelts used: No. 3 and No. 4, sizes 28 × 22 and 26 × 21 respectively.

Roller cloth will generally last about three leather coverings.

## RECIPES AND NOTES.

### PASTE FOR CLOTH:—

- 3 lb. best Austrian flour.
- 3 lb. amber resin, crushed into fine powder.
- 3 tablepoonsful of Venice turpentine.

(1) Place the flour in  $1\frac{1}{2}$  quarts of water and steep several hours before making the paste.

(2) Place the resin in a pan with  $1\frac{1}{2}$  quarts of boiling water, continue to boil for 25 minutes, then add turpentine and boil another five minutes. Add the steeped flour and boil all together, continually stirring to thoroughly mix the ingredients.

A little boiled oil may be added to the above, but its use prevents quick drying.

### CEMENT FOR LEATHER COTS OR TUBES:—

Take 3 oz. fine gelatine, soak in 4 fluid ounces rain or distilled water, stir frequently until soft; then boil, stirring rapidly until the whole is dissolved. When cold, the cement is solid; for use it must be melted, and applied hot.

CEMENT FOR PIECING LEATHERS.—Acetic acid and isinglass, about equal quantities of each.



**ROLLER VARNISH:—**

Take 1 lb. chrome yellow, and mix with  $\frac{1}{4}$  lb. lamp black and  $\frac{1}{4}$  lb. rouge. Roll well with a roller to take all the small lumps out. Take 10 oz. joiner's glue, and boil it in two quarts of water; add to the above, and let it simmer for half-an-hour, continually stirring it. If it should be thicker than ordinary paint, dilute with warm water, and bottle. Before using, this varnish should be slightly warmed.

---

Slack covering causes excessive wear in the leathers.

The quality of yarn spun is affected by the leather-covered rollers.

Never tear the cloth into strips, but cut the edges clean down with a sharp knife.

Cloth 27 in. wide and weighing from 16 to 20 oz. per yard is usually employed for the rollers.

Roller skins should never be cut into strips across the hide, but lengthways from head to tail, which is the direction of the growth.

Badly-covered rollers are a source of expense, they need frequent recovering. Roller cloth should be firm and springy, evenly woven and well milled.

*Rubbing or Fluting Rove:—*May arise from the top (leather-covered) roller and the bottom (fluted) roller being of the same diameter. After a time they tend to work together like a pair of toothed wheels. Or it may be due to the cushion effect of the cloth having been destroyed.

---

**Self-lubricating Weight Hook.**

**Function.**—To dispense with oiling by hand the necks of the draft rollers; to save lubricant; and to prevent damage to cotton by oil spots.

**Description.**—Is provided with a small chamber for the reception of grease, which is supplied every four or five weeks. A lid is fitted over the chamber to keep out dust and dirt, and a projecting shield excludes dust from choking up the outlet for grease.

## APPROXIMATE COSTS AND COMPARISONS IN A MULE AND A RING SPINNING MILL.

THE COST OF BUILDING, INCLUDING BOILER AND ECONOMISER SEATINGS, ENGINE FOUNDATIONS, AND CHIMNEY.

Estimated cost per suppl. foot of floor space occupied by mules for above for average 40's = about 3/4 per foot.

Estimated cost per suppl. foot of floor space occupied by ring frames for above on average 40's..... = about 3/8 per foot.

**Power** required for Ring Frames over Mules = 20% extra.

**Floor Space** for Ring Frames, including passages 2½ gauge = .633 sq. feet per ring spindle.

For Mules, including passage 1½ gauge = 1.11 sq. feet per mule spindle.

### PROPORTION OF FLOOR SPACE, RINGS v. MULES (WEFT).

Nos. Ring System	Sq. feet per spindle	Total	Nos. Mule System	Sq. feet per spindle	Total
24's Cardroom .....	.9	} = 1.52	25's Cardroom .....	.66	} = 1.65
Spinning .....	.62		Spinning .....	.99	
23's Cardroom .....	1.0	} = 1.66	22's Cardroom .....	.76	} = 1.76
Spinning .....	.66		Spinning .....	1.0	
35's Cardroom .....	.92	} = 1.59	34's Cardroom .....	.55	} = 1.65
Spinning .....	.67		Spinning .....	1.1	
36's Cardroom .....	.8	} = 1.51			
Spinning .....	.71				
50's Cardroom .....	1.1	} = 1.79	50's Cardroom .....	.73	} = 1.93
Spinning .....	.69		Spinning .....	1.2	

**Long Collars.**—These are sometimes made of steel, with a special arrangement for lubrication. The oil is poured in at the side of the collar on to a felt pad, which, when thoroughly saturated, serves as a feeder for oiling the bobbin-wheel. With this arrangement, oiling once a week suffices, and there is no danger of the lubricant getting into the yarn. The collars being made of steel, they are both light and strong.

BELOW is given approximately the proportion of machines in relation to each other for various counts, also the horse-power for spinning spindles, including preparing machinery:—

	Single Roving						Double Roving				+ Sets Speed Frames					
	10	10	20	30	40	50	60	70	80	90	100	80	95	100		
	Counts.....															
1 Card.....	300	300	555	800	1,050	1,111	1,176	1,111	1,176	1,250	1,333	1,250	1,333	1,250	1,428	1,428
1 Finished delivery .....	333	333	625	869	1,176	1,250	1,333	1,333	1,333	1,428	1,538	1,428	1,538	1,538	1,666	1,539
1 Slubbing spindle.....	27.6	49	72.7	87	103	113	129	134	121	135	123.4	178.5	243	263	243	263
1 Intermediate spindle .....	—	23	33.6	32.9	40	47.7	32.8	35.7	40	45.4	34	77.8	94	102	94	102
1 Roving spindle.....	11.26	11.26	14.5	10.5	12.5	15.5	9.12	9.29	9.3	9.9	7.2	27.8	30.8	31.3	30.8	31.3
2nd Roving spindle .....	—	—	—	—	—	—	—	—	—	—	—	—	—	—	8.75	7.29
1 h.p. = to spindles and preparation ...	47	45	55	60	64	66	63	66	68	68	66	67	67	67	67	67

	Single Roving						Double Roving	
	10	10	20	30	40	50	45	50
Counts.....								
1 Card .....	175	175	371	520	655	765	800	800
1 Finished delivery .....	185	190	415	580	714	833	870	909
1 Slubbing spindle .....	12.7	21.16	46.5	58.6	60.9	59.7	71	84
1 Intermediate spindle .....	—	9.8	18.46	22.17	23.3	25.38	28	32.8
1 Roving spindle .....	5.49	4.6	6.2	6.17	6.95	6.7	7.29	7.1
1 h.p. = to spindles & preparation	33	38	42	46	48	50	51	54

Ribs of Frames }  
 Spindles }

## TESTING OF SPINNING, &c., MACHINES

### POWER TESTS OF PREPARING AND SPINNING MACHINES.

By MR. CLEMENT J. CHARNOCK, of Sereda, Russia.

The following table shows the power absorbed by a Roving Frame containing 164 spindles, before and after the machine has been squared up by the mechanic. ↑

#### Power Absorbed by Roving Frame.

Sort and Classification of Cotton	Hank Roving produced	Speed of Frame Shaft, revs. per min.	Number of Spindles	Revolutions of Spindle per minute	Revolutions of (14 inch) Front Roller per min.	Turns per inch of Rove	Indicated H.P. with Lift on Top	Indicated H.P. with Lift on bottom	Average Indicated Horse Power
4th Texas G.M.	4.63	372	164	1060	112.3	2.4	2.00	2.30	2.15
4th Texas G.M.	4.63	376	164	1072	113.5	2.4	1.50	1.54	1.52

A difference of 29.3 per cent. is thus shown in the average indicated horse-power.

From the foregoing, it is deduced that by far the most common and serious cause of heavy running of frames is the lifting mechanism. This, when not traveling in a correct vertical line, binds the spindles, especially in its lower positions. It also puts extra strain on the cone belts—to the detriment of the winding.

#### Power Absorbed by Set of Bobbins.

The Diagram on next page shows the power absorbed from the beginning to the end of a set of bobbins. It will be seen therefrom that the power decreases considerably until about the 35th row of rove, after which the diminution is more gradual.

This irregular variation conforms to the shape of the cone drums, and is caused by the necessary decrease in speed of the bobbins and lifter rail as the bobbins enlarge. The sudden rise of the line between the 25th and 35th row was accounted for by an accumulation of fly in the delicate mechanism of the dynamometer, which impeded its action. It will be observed the diagram indicates that the decrease of power due to slower speed of the bobbins as they decrease in diameter is

$$\left(100 - \left(\frac{100 \times 1.49}{1.62}\right)\right) = 8\%$$

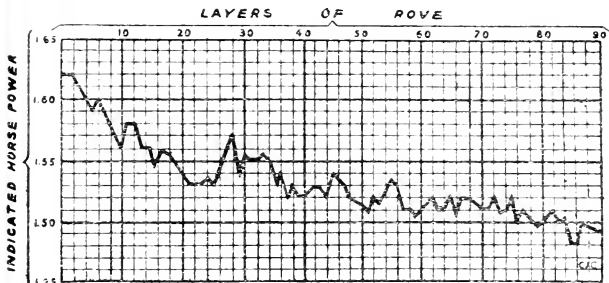

The next Diagram (p. 142) shows the result of another test on the same machine, giving the power distributed to the various motions. The test was made when the bobbins were three-quarters formed, and the total H.P. delivered to the frame in full operation was 1.53. The frame contained 164 spindles. Speed of shaft, 400 revolutions; speed of spindles, 1,000 revolutions per minute. Roving, 5 hank, with 2.35 turns per inch.

Or in the following percentages:—

The machine in full motion takes	1.53 I.H.P. or .....	100	per cent.
Drafting the cotton requires	0.072 I.H.P. or .....	4.70	„
Revolving the drafting rollers takes	0.120 I.H.P. or .....	7.84	„
The lift takes	0.036 I.H.P. or .....	2.36	„

The bobbins take 0.522 I.H.P. or ..... 34.12 per cent.  
 The spindles (with frame shaft friction) 0.780 I.H.P. or ..... 51.98 ,,

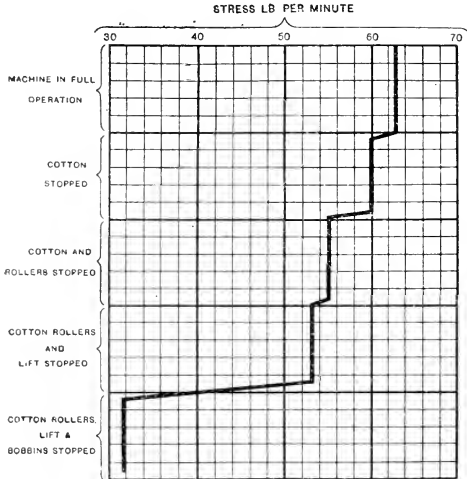

*Note.*—It is a common occurrence to find frames absorbing as much as .014 H.P. per spindle, and even higher, especially where the floors are inferior asphalt and no precautions have been taken to prevent the machine from sinking. As the weight of a rover complete, including weights and full bobbins, is from 60 lb. to 70 lb. per spindle, this, in conjunction with vibration, confirms the necessity for a firm foundation.

**Power for Driving Self-acting Mules.**

The Diagrams on p. 143 are records of power consumed in driving two self-acting mules, containing 780 and 1,000 spindles respectively, constructed by different makers:—

**MULE DIAGRAM**

CONTAINING 780 SPINDLES SPINNING 20'S

COUNTER SHAFT: 529.4 REVS

HP CARRIAGE RUNNING OUT 9.7

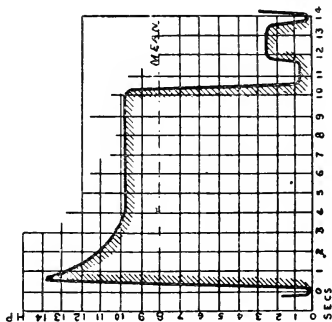

**MULE DIAGRAM**

CONTAINING 1000 SPINDLES; SPINNING 30'S

COUNTER SHAFT: 422 REVS

HP CARRIAGE RUNNING OUT 14.26

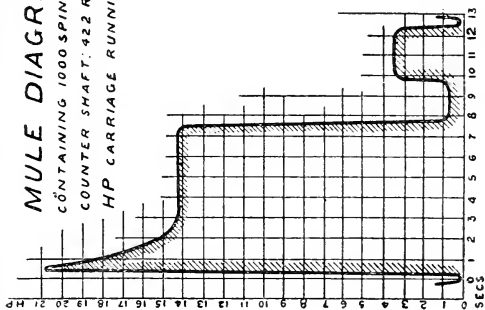

**Tachometers.**—These are speed indicators, for showing at a glance (and without the assistance of a watch) the number of revolutions per minute made by a shaft spindle or other rotating object. The mechanism of the instrument is based on the principle that, when making a test, there is needed for high speeds only a slight pressure against the rotating object, while for slow speeds more pressure is required. The axis of the apparatus is carried internally in a slide, which is fitted with a spring that exerts an outward pressure. The instrument being applied lightly to the shaft, etc., under test,

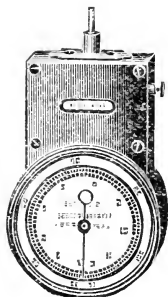

TACHOMETER.

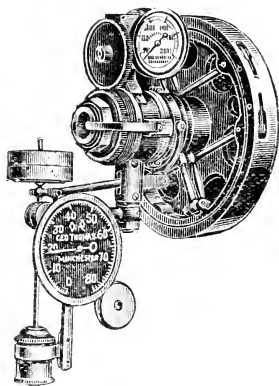

DYNAMOMETER.

the axis remains in the first position, when the range for highest speeds is in gear. When more pressure is applied, the slide carrying the axis recedes one step, whereupon other ratio wheels come into gear, thus connecting the second range. Still further pressure brings into operation the third range, and finally the fourth range for still smaller numbers of revolutions.

When desired, the axis can be locked at any one range by a half-turn of a bayonet-lock stud, fitted to the side of the wheel-case. The instrument is made in three sizes, with ranges varying from 3 to 5.

**Transmission Dynamometers.**—These instruments are really power-weighting scales, inasmuch as the power transmitted through them is weighed after the manner



of an ordinary "platform" weighing machine. The apparatus is generally attached to the projecting end of the machine driving-shaft. It is provided with two driving pins, which engage with the loose pulley of the machine, so that when the latter is turned by the strap or rope, the apparatus revolves with it. Accordingly, when the latter is secured to the shaft, and the strap or rope is on the loose pulley, the power driving the machine must be transmitted through the apparatus. By suitable lever mechanism the power thus exerted is indicated in pounds on a graduated dial, which constitutes the dynamometer proper. After testing a machine in full motion, this apparatus can be used in ascertaining the power absorbed in any separate portion thereof.

#### COMPARATIVE HORSE-POWERS.

1 Brake horse-power	=	1.1	Indicated horse-power.
1 " " "	=	1.18	Electrical " "
1 Indicated " "	=	1.08	" " "

## COTTON AND YARN TESTING

### FOR MOISTURE.

All textile materials are hygroscopic: that is to say, they are capable of absorbing moisture from the atmosphere. Cotton contains 7 to 8 per cent. of water as a natural constituent; and if any or all of this be extracted, the cotton will, upon exposure to a suitable atmosphere, again absorb moisture up to the above normal percentage. Cotton may, however, easily contain twice the latter percentage without either altering in appearance or feeling unduly damp. With a material liable to such wide fluctuations—which may be due to the natural condition of the atmosphere, to the temperature of the spinning rooms, or to fraudulent practices—the necessity for a "standard" regarding moisture will be evident.

The standard now generally accepted is that known as a "regain" of certain percentages, which are given, for

the various materials, on a later page. In the case of cotton the regain is  $8\frac{1}{2}$  per cent., meaning thereby that if 100 lb. of absolutely dry cotton—*i.e.*, cotton from which every particle of moisture, including the normal, has been extracted—if 100 lb. of such cotton were exposed to the atmosphere, it would absorb  $8\frac{1}{2}$  lb. of moisture. That is to say, cotton is considered to be in the "standard" condition when  $108\frac{1}{2}$  lb. contains  $8\frac{1}{2}$  lb. of moisture, this being equal to 7.83 per cent.

To ascertain the condition, a definite quantity of material is heated until absolute dryness is attained, the same being determined by frequent weighings and continuance of the heat until no further loss takes place. The addition of the percentage regain to the final weight then gives the weight in the correct condition. It is essential that the weighing be performed without removal of the material from the influence of the heat, otherwise reabsorption would immediately commence, and would interfere with the correctness of the result.

A reliable **Testing Oven** consists of two concentric cylinders, having an annular space in which heated air can freely circulate. The heat is obtained from a Bunsen ring burner fixed beneath the inner cylinder; outlet tubes ensure complete circulation of the heat and uniform drying of the material, and also removal of steam and moisture. A thermometer with bulb reaching half-way down the inner cylinder is provided to register the temperature within. Material in loose condition, or in the form of cops, is placed in the cage, and if in hanks is placed upon the reel, after which the whole is suspended within the cylinder from the scale end. The reel or cage exactly balances the weight end, so that weights in the latter represent net material.

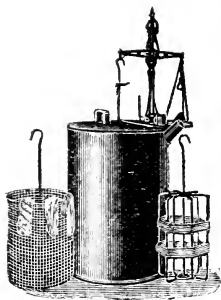

### Testing Raw Cotton.

To make a test, samples making a total of  $1\frac{1}{2}$  or 2 lb. are collected from different parts of the bulk, and placed as loosely as possible within the oven and then weighed. Next, the heat is turned on; and, 10 to 15 minutes after a

temperature of 220 deg. to 230 deg. F. has been attained, weights are placed in the small pan attached to the cage wire, to restore equilibrium. The material is then shaken and turned top to bottom, and again submitted to the heat, and weighed at intervals of 5 to 8 minutes—until a constant weight, indicating absolute dryness, is obtained. The weights in the cage pan represent loss or moisture, and the same subtracted from the original weight (which has remained undisturbed throughout the operation) gives the dry weight. The addition of the percentage regain to the latter then gives the correct weight, or weight in the correct condition.

*Example I.*—Suppose 2 lb. of cotton, taken from a 480 lb. bale, to lose 4 oz. in drying. The dry weight is thus 1 lb. 12 oz., or 28 oz. Adding  $8\frac{1}{2}$  per cent. of the latter (namely, 2.38), we obtain 30.38 oz. as the correct weight. Then, by proportion, if the correct weight of 2 lb. or 32 oz. be 30.38 oz., what is the correct weight of 480 lb.?

$$\begin{array}{r} 30.38 \times 480 \\ \hline \phantom{30.38} \phantom{\times} \phantom{480} = 455.7 \text{ lb.} \\ 32 \end{array}$$

Excess moisture =  $480 - 455.7 = 24.3 \text{ lb.}$

*Example II.*—From a skip of cotton yarn weighing 260 lb. net,  $1\frac{1}{2}$  lb. of cops is taken for testing. When absolutely dry, they weigh 1 lb.  $5\frac{1}{4}$  oz. Can any claim be made for excess moisture? If so, to what amount, assuming the yarn to cost  $10\frac{1}{2}$ d. per lb.

$$\begin{array}{r} \text{Dry weight} \dots\dots\dots 21.25 \text{ oz.} \\ \text{Add } 8\frac{1}{2} \text{ per cent.} \dots = 1.80625 \end{array}$$

$$\text{Correct weight} \dots \dots 23.05625$$

$$\begin{array}{r} \text{Original weight} \dots\dots 24 \text{ oz.} \\ \text{Correct weight} \dots \dots 23.05625 \end{array}$$

$$\text{Excess moisture} \dots \dots .94375$$

$$.94375 \times 260$$

$$\text{Total excess moisture} = \frac{\phantom{.94375} \phantom{\times} \phantom{260}}{1\frac{1}{2} \times 16} = 10.22 \text{ lb.}$$

$$\text{Amount of claim } 10.22 \text{ lb. at } 10\frac{1}{2} \text{d.} = 8 \text{ s. } 10\frac{1}{2} \text{d.}$$

Excepting in the case of silk, which will stand up to 248 deg. F., the above-named temperature should not be exceeded—otherwise scorching of the material will result.

### Standard Regains.

The following is the list of "Standard Regains" together with the equivalent direct losses:—

Material	Regain.	Loss from normal condition.
Wool scoured .....	16 per cent. ....	13.79 per cent.
„ tops in oil.....	19 „ .....	15.96 „
„ tops dry.....	18 $\frac{1}{4}$ „ .....	15.43 „
„ noils .....	14 „ .....	12.28 „
„ yarns.....	18 $\frac{1}{4}$ „ .....	15.43 „
Silk .....	11 „ .....	9.91 „
Cotton .....	8 $\frac{1}{2}$ „ .....	7.83 „
Flax .....	12 „ .....	10.71 „
Jute .....	13 $\frac{3}{4}$ „ .....	12.09 „
Hemp .....	12 „ .....	10.71 „

### TESTING FOR COUNTS.

Yarn is tested for counts by measuring off a definite length, from the weight of which the counts can be calculated. For cotton yarns the standard testing length is the lea of 120 yards, or one-seventh of a hank. This length is measured by the wrap reel. The circumference of the reel is 54 inches, or 1 $\frac{1}{2}$  yards: therefore 80 revolutions make the lea, and the completion of the same is indicated by the ringing of a bell. Usually the handle is geared so as to make only one revolution for two of the reel.

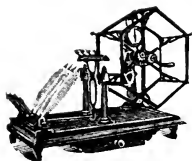

Machines are made to wrap from four to seven cops or bobbins, but hanks must be placed upon ryces or swifts, and wound one thread at a time. Uniform tensioning and traversal of the threads during winding have an important effect upon the result; in the former respect the ordinary machines are very deficient. For weighing the leas, finely adjusted balances, capable of indicating differences of at least one-tenth of a grain, should be used.

When the count of one cop only has to be ascertained, the reel is stopped at the completion of each lea, and the thread is passed through the next guide eye in the traverse rail, and so on until the required number of leas has been wound on the reel. This operation, which involves additional attention, may be done automatically by a recently-patented device, which is actuated by the

measuring motion. When in action, the latter causes a rod to rotate. This rod is provided with a series of stops, arranged spirally round its circumference, and of a number corresponding with the leas to be wound. For every part of a revolution made by this rod, the guide through which the thread passes moves one step forward. The operation is repeated until the full wrap has been made.

The pennyweights and grains are Troy weight and the ounces and pounds Avoirdupois, this combination being used because the smallest weight of the latter table—the dram of  $1/256$  lb.—is not sufficiently small for testing purposes.

*To find the Counts of Cotton Yarn.*—Divide 1,000 by the weight of a lea in grains. Thus, if one lea weighs 2 dwts. 2 grains—*i.e.*, 50 grains—the counts is  $1,000 \div 50 = 20$ 's. If two leas be wrapped (as is sometimes the case) with very fine yarns, 2,000 must be taken as a dividend. From the formula  $1,000 \div \text{grains} = \text{counts}$ , we can obtain  $1,000 \div \text{counts} = \text{weight of a lea in grains}$ . By the aid of this, a wrapping table can be constructed to save the necessity for calculating. Thus,  $1,000 \div 25 = 40$  grains = 1 dwt. 16 grains for a lea of 25's,  $1,000 \div 36 = 36.15 = 1$  dwt. 12.15 grains. A portion of such a table is given herewith.

When complete leas are not available, shorter lengths can be measured by the **Wrap Reel**, which is provided with a dial indicating up to 120 yards, and the counts are calculated therefrom. Thus the weight of a lea can be found by proportion, and the preceding rule or tables may be used; or the count may be calculated direct. In the latter case, the following formula will be found convenient:—

$$\frac{\text{Yards} \times 100}{\text{Grains} \times 12} = \text{Counts.}$$

Thus, if 40 yards weigh 12 grains, the counts is—

$$\frac{42 \times 100}{12 \times 12} = 27.77 \text{ Counts.}$$

Short lengths of yarn are conveniently tested by the **Quadrant**. The arc has three scales engraved upon its face, the lower of which is used to indicate the counts of four yards, and the middle scale when 40 yards are tested. The first length is obtained by cutting 40

threads to a templet of one-tenth yard, and the second by wrapping a thread 40 times round a half-yard templet. When either length is hung upon the hook, the pointer indicates the count upon the corresponding scale. The top scale gives the weight of 100 yards of cloth 36 inches wide, when a piece one-tenth yard square (cut by the aid of the smaller templet) is hung upon the hook.



The smaller templet is chiefly used to test the counts of yarn from cloth. In this respect it is advisable to remember that the waviness due to interweaving should be removed by stretching the threads before they are cut; and also that any size or filling should be cleared away by boiling, otherwise the true count cannot be obtained. When bleached or dyed yarns are tested, allowance must be made for the influence of these processes upon the weight and counts of the yarn.

The "Thomas" balance is also used for testing the counts of yarn from cloth. Threads are cut to templets provided, and the number of these that balance the wire beam gives the count. The pendulum shown has its upper end bent at right angles and balanced by a counterpoise. Thus the upper end always assumes a horizontal position whatever be that of the supporting pillar; and it is then an easy matter to determine when the wire beam is exactly balanced.

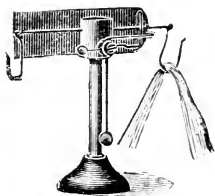

### TESTING FOR STRENGTH AND ELASTICITY.

The machine in general use for this purpose is the Lea Tester. A lea of yarn from the wrap reel is placed upon the hooks, and the lower one is then caused to descend by turning the handle. Thereupon the upper hook pulls round a small drum, into which a weighted lever is bolted, thus causing the weight to travel outwards and pull against the yarn until the latter breaks, at which point the weight is supported by a curved rack. A sector on the drum moves a finger in front of the dial, on which is engraved a scale of lb., representing the dead-weight pull.

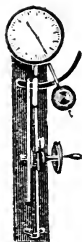

Elasticity or stretch is measured by means of two small scales of inches engraved upon the pillar opposite to the upper and lower hooks. Thus the distances travelled by the two hooks, during the making of a strength test, can be observed.

Suppose the upper hook to travel  $1\frac{1}{4}$  inches while the lower one moves  $2\frac{3}{4}$  inches, then the difference is  $1\frac{1}{4}$  inches, or a total of 3 inches upon the length of the lea, the latter being doubled when on the hooks. The lea being 54 inches, the stretch is equal to—

$$\frac{3 \times 100}{54} = 5.56 \text{ per cent.}$$

### TESTING FOR TWIST.

Testing for twist consists in untwisting a thread and noting the number of turns per inch given before complete parallelism of fibres or threads has been obtained. Single threads are not usually tested for twist, as a turn or two more or less does not materially affect the strength or appearance of the ordinary run of single yarns; and manufacturers do not concern themselves about the exact number of turns so long as there is sufficient strength for working purposes, and sufficient fulness to give a well covered fabric. But doubled yarns are invariably so tested, on account of the influence of the twist upon their appearance and suitability for the special purposes to which they are to be applied.

The figure shows an ordinary Twist Tester, in which the left-hand pillar is fixed and is provided with split jaws capable of being tightly screwed together to grip the thread. The right-hand pillar is movable upon a brass scale engraved with inches, and is provided with a hand-wheel attached to or geared with a split spindle, which receives the thread. When the movable pillar has been fixed at the desired distance and the thread secured in the jaws and spindle, the latter is revolved until the whole of the twist has been removed. The number of revolutions is indicated upon a dial; and this number divided by the number of inches tested, gives the number of turns per inch.



To test single threads, a machine is made in which both pillars carry spindles, so that twist can be taken out from both ends of the thread, for, with the arrangement above described, it frequently happens that one end having been untwisted begins to retwist in the opposite direction before the other end has been untwisted.

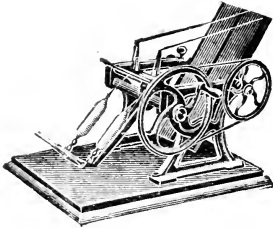

### Regularity.

The Yarn Examining Machine is used to examine and compare the quality, evenness, and freedom from defects of yarns. A stout sheet of black carboard is held by revolving clips, driven by the hand-wheel. When the latter is turned, the thread is evenly wound at close intervals

upon the card, but sufficiently apart to reveal any unevenness or faulty places, which quickly show up against the dead-black surface of the board. The cards are removable, and can thus be labelled and kept for reference.

Although the above method of testing is most commonly practised by spinners, it is thought by some not to give the best average results, inasmuch as the strength of the stronger threads is not taken into account, and only a percentage of the weaker ones. What the test gives is merely the approximate strength of an unknown quantity of weaker threads.



Single-thread testers are now available worked on both the spring and dead-weight principle, by means of which the breaking strength of each individual thread is ascertained; and, with the latest types of machines, a multiplicity of threads can be tested simultaneously. From these results an average that is reliable may be deduced.

It is really a scientific test, one of great value. By means of a patent apparatus, the tests made on these machines are recorded in diagram form, to be kept for reference.



## DEFECTIVE YARN: ITS CAUSES, EFFECTS, &amp;c.

## Single Yarn.

**Dirty Yarn.**—This occurs when the processes of opening and preparing the cotton have failed to remove all suspended impurities. These usually consist of fragments of leaves and seeds adhering to the fibres.

**Stained Yarn.**—May be caused by the working-up of stained cotton, but is chiefly due to carelessness of the mill operatives in allowing oil to come into contact with the yarn. Is also often caused by a broken thread not receiving immediate attention, and striking some part of the machine, thus picking up grease and dirt. This it conveys to its neighbour when pieced-up. Stained yarn may sometimes arise from operatives having dirty hands, or from impure water when the doubling is on the "wet" principle.

**"Nepped" Yarn.**—So named because it contains small pieces of hard cotton, called "neps." These vary in size from very small particles, to others the size of a pin-head. There are two kinds—commonly distinguished as "natural" neps and "mill" neps. The former consist of short and undeveloped fibres that have become embedded in the yarn. The latter ("mill" neps) are impurities and also short fibres usually found adhering to the surface of the threads.

**'Slubs' or 'Ooze.'**—These occur when the twist in the yarn is not uniform. They appear as thick places, which have received insufficient twist. They are caused by what is called "thick" or "jammed" roving: that is, two rovings overlapping each other (say an inch or more), which thus pass through the rollers without receiving the amount of twist required.

**"Snarls."**—These are curls or loops in the yarn and are caused chiefly by bad winding in the mule. This may sometimes be traced to faulty spindle-blades, the tops of which interfere with the coiling of the yarn on the cop.

**"Snicks."**—Places where the yarn is almost cut through. They are attributable to the use of badly covered rollers, or to over-weighting. Sometimes they are due to the draft rollers being too wide in the settings for the length of staple spun, thus causing undue stretch in the yarn.

**Irregular Yarn.**—The result of bad spinning; seldom seen in the productions of firms of high standing.

### Doubled Yarn.

**Corkscrew Yarn.**—Occurs when one of two or more folded threads is imperfectly twisted, and—not clinging closely to its neighbour—coils loosely round in a "corkscrew" fashion: hence it derives its designation. The same fault may arise from imperfect tension on some of the threads.

### Standard Twists for Single "American" Yarn.

For Warp,  $\sqrt{\text{Counts}} \times 3.75$

For Weft,  $\sqrt{\text{Counts}} \times 3.25$

### Strengths of Ring Yarn.

The following table gives the average of ten tests in each case of a standard ring yarn spun from American cotton:—

Weight of Lea in Grains	Counts	Strength in lb.
63.3	15.79	118
54.6	18.31	102.9
50.25	19.90	92.3
44.9	22.27	80.8
41.2	24.27	72.6
37.3	26.80	66.3
35.0	28.57	63.2
32.65	30.62	58.5

### Table of Weights Used in Testing Cotton Yarns.

24 grains make 1 dwt.

109 $\frac{3}{8}$  grains or 4 dwts. 13 $\frac{3}{8}$  grs. make  $\frac{1}{4}$  oz.

218 $\frac{3}{4}$  grains or 9 dwts. 2 $\frac{3}{4}$  grs. make  $\frac{1}{2}$  oz.

437 $\frac{1}{2}$  grains or 18 dwts. 5 $\frac{1}{2}$  grs. make 1 oz.

7,000 grains or 16 oz. make 1 lb.

The dwts. and grains are troy weight; the oz. and lb. avoirdupois weight.

**Cotton Yarn Measure.**

54 inches	=	1 thread	(or circumference of wrap reel).
4,320 "	=	80 "	= 1 lea.
30,240 "	=	560 "	= 7 " = 1 hank.
		1 Hank	= 840 yards.
		1 Bundle	is usually 10lb. in weight.
No. of yards	÷	8.33 grains	= Counts of Yarn.

**French System of Numbering Yarns.**

1,000 metres,	weighing	500 grammes	=	No. 1's.
1,000 "	"	250 "	=	" 2's.
1,000 "	"	50 "	=	" 10's.
1,000 "	"	25 "	=	" 20's.

*Rule*—Number of metres reeled, *divided* by twice the weight of grammes.

To reduce English to French numbers, *divide* by 1.18.

**BOBBIN STRIPPING APPARATUS.**

**Function.**—Strips the waste or last few layers of thread from pirns, bobbins, and roving tubes, without injury to the wood of the bobbin.

**Description.**—The apparatus consists of a rack and pinion, with stripping device fixed to the upper part of the rack. The stripper is provided with movable jaws, which are closed inwards to follow the

contour of the bobbin during the time the stripping is taking place.

The machine is first adjusted to take in the size of bobbin or pirn by placing the tip of the bobbin into a cup-ended spindle, and the base into the stripper, which gives the length of stroke to be made by the rack during the operation. A stop-collar is then brought up, and is secured in its place by a thumb-screw.

The work of stripping then proceeds, by the operator placing the bobbins, one after the other, in position, closing the stripper with the finger and thumb of the left hand, and turning the handle with the right until the stroke is completed. (Apparatus patented.)

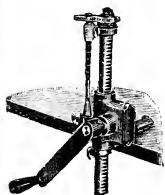

TABLE OF YARN LENGTHS AND WEIGHTS.

Showing at a glance the length of Yarn per pound by the weight of any number of Leas, from 1 to 7, and the length of any one pound from 1 to 350 Hanks. 1 Lea = 120 yards. 1 Hank = 840 yards or 7 Leas. Thus—2 Leas weigh  $\frac{1}{2}$  oz., 1 dwt., 7,267 grains. Under 2 Leas you will find this weight, then in side column the number 8. That is, 8 Hanks to one pound = No. 8.

The ounces used are Avoirdupois; the pennyweights and grain weights are Troy.

Hanks	1 Lea		2 Leas		3 Leas		4 Leas		5 Leas		6 Leas		7 Leas							
	Oz.	Gr.	Oz.	Gr.	Oz.	Gr.	Oz.	Gr.	Oz.	Gr.	Oz.	Gr.	Oz.	Gr.						
1	2	5	4 $\frac{1}{2}$	1	7,267	6 $\frac{1}{2}$	6	12,338	9	2	14,535	11	7	19,606	13 $\frac{1}{2}$	3	21,801	16	0	0,000
2	1	2	2	5	5,071	3	7	19,606	1 $\frac{1}{2}$	1	7,267	5 $\frac{1}{2}$	3	21,803	6 $\frac{1}{2}$	6	12,338	8	0	0,000
3	$\frac{1}{2}$	4	1 $\frac{1}{2}$	0	10,422	2	5	5,071	3	0	20,845	3 $\frac{1}{2}$	5	15,493	4 $\frac{1}{2}$	1	7,275	5	6	1,924
4	$\frac{1}{2}$	1	1	2	14,536	1 $\frac{1}{2}$	3	21,704	2	5	5,071	2 $\frac{1}{2}$	6	12,339	3	7	19,607	4	0	0,000
5	0	8	$\frac{1}{2}$	7	13,353	1	6	18,592	1 $\frac{1}{2}$	5	23,831	2	5	5,071	2 $\frac{1}{2}$	4	10,310	3	3	15,549
6	0	6	$\frac{1}{2}$	4	18,649	1	2	14,536	1 $\frac{1}{2}$	0	10,423	1 $\frac{1}{2}$	7	9,185	2	5	5,071	2 $\frac{1}{2}$	3	0,958
7	0	5	$\frac{1}{2}$	2	19,003	$\frac{1}{2}$	8	17,942	1	5	14,006	1 $\frac{1}{2}$	2	10,070	1 $\frac{1}{2}$	8	9,009	2	5	5,071
8	0	5	$\frac{1}{2}$	1	7,267	$\frac{1}{2}$	6	12,339	1	2	14,536	1	7	19,607	1 $\frac{1}{2}$	3	21,804	2	0	0,000
9	0	4	$\frac{1}{2}$	0	3,474	$\frac{1}{2}$	4	18,649	1	0	6,948	1	4	22,123	1 $\frac{1}{2}$	0	10,423	1 $\frac{1}{2}$	5	1,597
10	0	4	0	8	8,114	$\frac{1}{2}$	3	9,296	$\frac{1}{2}$	7	13,354	1	2	14,536	1	6	18,593	1 $\frac{1}{2}$	1	19,775

## UNIVERSAL TABLE FOR NUMBERING COTTON, LINEN, AND WORSTED YARN.

No.	Grains	No.	Grains	No.	Grains	No.	Grains	No.	Grains	No.	Grains
5	1400.	24	291.8	43	162.8	62	112.9	81	86.4	100	70.
6	1166.6	25	280.	44	159.2	63	111.1	82	85.4	105	66.7
7	1000.	26	269.3	45	155.6	64	109.3	83	84.3	110	63.6
8	875.	27	259.3	46	152.2	65	107.7	84	83.3	115	60.9
9	777.8	28	250.	47	148.9	66	106.1	85	82.4	120	58.3
10	700.	29	241.5	48	145.8	67	104.4	86	81.4	125	56.
11	636.4	30	233.4	49	142.8	68	102.9	87	80.4	130	53.8
12	583.3	31	225.8	50	140.	69	101.4	88	79.5	135	51.8
13	538.5	32	218.8	51	137.3	70	100.	89	78.6	140	50.
14	500.	33	212.2	52	134.7	71	98.6	90	77.8	145	48.3
15	466.8	34	206.	53	132.1	72	97.2	91	76.9	150	46.7
16	437.5	35	200.	54	129.7	73	95.9	92	76.1	155	45.2
17	411.9	36	194.6	55	127.3	74	94.6	93	75.3	160	43.8
18	389.	37	189.3	56	125.	75	93.3	94	74.5	165	42.4
19	368.5	38	184.3	57	122.8	76	92.1	95	73.7	170	41.2
20	350.	39	179.6	58	120.7	77	90.9	96	72.9	175	40.
21	333.3	40	175.	59	118.6	78	89.7	97	72.3	180	38.9
22	318.3	41	170.8	60	116.7	79	88.6	98	71.4	190	36.8
23	304.5	42	166.7	61	114.8	80	87.5	99	70.7	200	35.

To Number Cotton Yarn.—Reel 840 yards = one hank. Weigh this, and against its weight of grains in the table will be found its number or count.

To Number Linen Yarn.—Reel 300 yards = one lea. Weigh it, and against its weight of grains in the table will be found its number or count.

To Number Worsted Yarn.—Reel 560 yards = one skein. Weigh it, and against its weight of grains in the table will be found its number or count.

### YARN CONDITIONING MACHINE.

**Function.**—Applies moisture to yarn in hanks, cops, or on ring frame bobbins, by mechanical means, in definite quantities, and without having to depend upon atmospheric conditions.

**Description.**—The material to be operated upon is placed on a travelling apron, which passes under a humidifier, consisting of two spraying nozzles. These nozzles are each provided with small propellers, in which spiral grooves are cut. The water, passing through the grooves under pressure, is caused to revolve very quickly, and is discharged from the nozzle in the form of a fine spray. The water is drawn from a tank through a sieve by means of a power pump, and is discharged into a chamber. While still under compression, the water in this chamber is sent through the sprayers. All water not taken by the material flows back into the supply tank, to be used over again. The material passes through the machine continuously, and after receiving the proper degree of moisture is deposited into a skip or other convenient receptacle. The amount of moisture is regulated by means of change-wheels between the driving wheel and the lattice roller wheel.

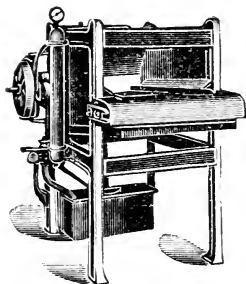

**Pulley.**—15 in. × 2 in.; speed, 100 revs. per minute.

**Production.**—3,000 lb. per day.

**Floor Space.**—4 ft. × 3 ft.      **Attendance.**—One youth.

In another method the yarn to be moistened is placed in wire cages suspended from overhead pulleys. When fully charged, the cages are lowered by means of a hand-wheel into a tank of water. Having absorbed sufficient moisture, the cages are raised again, and taken to a well-ventilated store-room. Here they "mature" by the moisture distributing itself throughout the bulk, until the condition of the yarn has become normal.

# SECTION IV:

DOUBLING

DOUBLING-WINDING

GASSING

REELING, BUNDLING

---

THREAD, LACE, HOSIERY, AND  
NEPPED YARNS

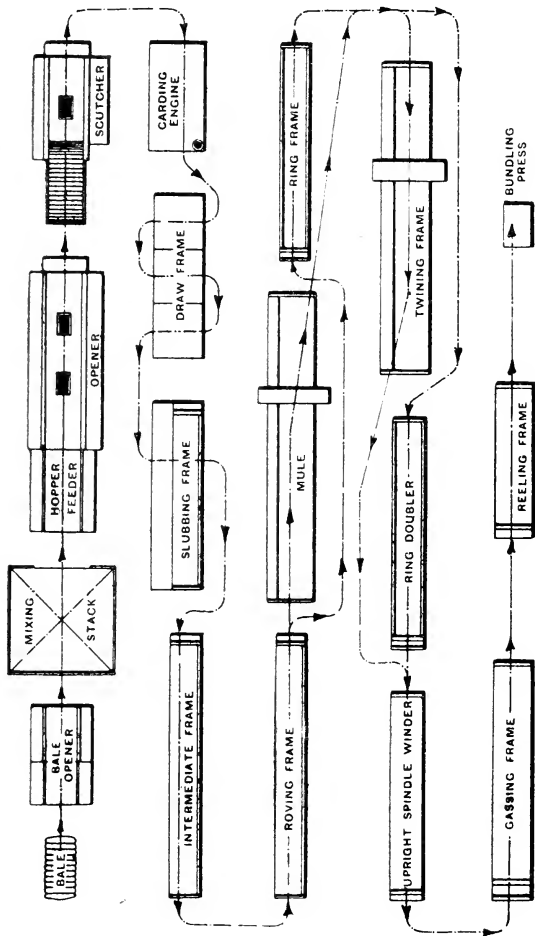



SEQUENCE OF MACHINES FOR RING AND MULE YARN FOR BUNDLING.



## DOUBLING

**Function.**—To twist two or more threads together to form a stronger thread, for use as warp yarn in weaving fabrics; in the manufacture of lace and hosiery; and in the making of sewing, crochet, and other cottons. Doubled yarn is also used in mercerising.

The twist is usually put into the yarn in the direction opposite to that in which it has been spun. Yarn for doubling is mostly spun twist-way and doubled weft-way. When twisted in the opposite direction, the threads tie more closely together, and the twist taken out of the single yarn is put into that which is doubled. There is also less contraction of the thread than when doubled the same way. The counts of doubled yarn are expressed according to the number of threads twisted together: thus three threads of 60's yarn twisted together constitute 60's three-fold, expressed "60/3," etc. The counts of the single yarn are invariably named.

When twisted to the **RIGHT** (thus ) it is called the **TWIST** way; when to the **left** ( ) the **WEFT** way. The terms "twist" and "weft" way, do not necessarily imply that the yarn itself is twist or weft.

Yarns used for doubling are of a very varied kind, and are distinguished by the degree of hardness in their manufacture.

In doubling, as in spinning, the operation may be either continuous or intermittent. The latter is carried out on what are known as **TWINERS**, which are worked on a principle similar to the self-acting mule. This system is mostly followed in dry doubling, and for yarns wherein it is desired to retain the hairy condition of the yarn after doubling.

Continuous doubling (either wet or dry) is done on both the flyer and the ring frames. There are two

recognised systems in vogue, known as the English and the Scotch systems respectively.

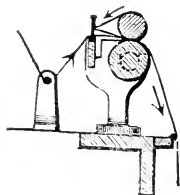

#### English System—

In dry doubling on the English system, the yarn from the bobbins is passed under a rod and over a glass slit guide between the nip of the rollers and over the top roller. It is then passed round a small glass peg, thence through the rollers again and forward to the doubling spindles.

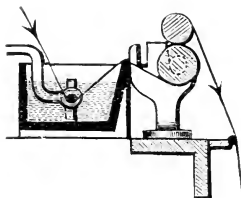

In wet doubling on the same system, the yarn passes under a glass rod in a water trough, before encountering the nip rollers. The trough containing the water is independent of and is placed behind the nip rollers. In this system the troughs are usually made in short lengths. The rod mentioned is provided with an arrangement by means of which it may be lifted clear of the trough for cleaning and other purposes.

#### Scotch System—

In the Scotch system the rod is dispensed with, and the nip rollers work in the trough. The bottom roller, which is usually of hollow brass, is partly immersed in the water. Provision is made for lifting the rollers out of the trough for the purposes above mentioned. In this system the yarn is considered to become more thoroughly saturated with the water than when rods only are used.



## RING DOUBLING FRAME.

**Description.**—The machine resembles the ring spinning frame, except that there is only one line of rollers, there being no draft. The rollers are made heavy enough to give the requisite nip to the yarn.

**Feeding.**—The yarn to be doubled is fed to the rollers from a creel, of sufficient capacity for the number of threads to be twisted.

**Pulley.**—12 in. dia.  $\times$  3 in. wide.

**Speed.**—About 6,500 revs. per minute, according to counts.

**Power.**—50 spindles per I.H.P. dry doubling; 45 spindles per I.H.P. wet doubling.

**Production.**—Of 30/2's, with  $15\frac{1}{2}$  turns per inch— $44\frac{1}{2}$  hanks per week of  $56\frac{1}{2}$  hours.

**Floor Space.**—Width, 3 ft. Length, one-half the number of spindles in frame  $\times$  space between spindles. Add 2 ft. 6 in. for gearing, off end, and width of driving pulley.

By rearranging the thread guides and passing the yarn backwards and forwards twice, it becomes possible to dispense in doubling frames with the top rollers and parts connected therewith. The power absorbed in driving a frame is thereby reduced, the starting and stopping of the frame is made easier, and the squeezing action of the top roller upon the yarn no longer takes place. A patent has been taken out for this purpose.

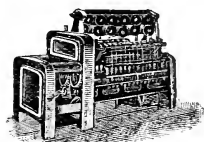

**To find the Weight of a Set of Bobbins with Indicator as basis:—**

Folds of yarn  $\times$  number of bobbins  $\times$  yards indicated  $\div$  counts  $\times$  840 yards = Weight of Set.

In hard-twisted yarns, about 6 per cent. should be allowed for contraction over that indicated as turned off by the rollers.

**To find average Length in Yards on a Set of Bobbins:—**

Counts  $\times$  net weight of set  $\times$  840 yards  $\div$  number of bobbins  $\times$  folds of yarn = Length in Yards.

## Travellers for Wet Doubling.

For Wet Doubling; rings  $1\frac{3}{4}$  in. and 2 in. dia. Spindles making 7,000 revs. per min.

Counts of Yarn.	No. of Traveller.			Counts of Yarn.	No. of Traveller.		
	2-Ply.	3-Ply.	4-Ply.		2-Ply.	3 Ply.	4-Ply.
4	14	13	4	66	20	20	17
6	15	14	5	68	20	20	17
8	15	14	6	70	21	20	17
10	16	15	7	72	21	20	17
12	16	15	8	74	21	20	17
14	16	15	9	76	21	20	18
16	16	15	10	78	21	20	18
18	17	16	10	80	21	20	18
20	17	16	11	82	21	20	18
22	17	16	11	84	21	20	18
24	17	16	12	86	21	21	18
26	18	17	12	88	21	21	18
28	18	17	12	90	22	21	19
30	18	17	13	92	22	21	19
32	18	17	13	94	22	21	19
34	19	18	13	96	22	21	19
36	19	18	13	98	22	21	19
38	19	18	14	100	23	22	20
40	19	18	14	110	23	22	20
42	19	18	14	120	24	23	21
44	19	18	15	130	24	23	21
46	19	18	15	140	25	24	22
48	19	18	15	150	25	24	22
50	20	18	16	160	26	25	23
52	20	19	16	170	26	25	23
54	20	19	16	180	26	25	23
56	20	19	16	200	27	26	24
58	20	19	16	210	27	26	24
60	20	19	16	220	27	26	24
62	20	19	16	230	28	27	25
64	20	19	17	240	28	27	25
				250	28	27	25

When doubling on rings of  $2\frac{1}{2}$  in. dia., travellers a size lighter than the foregoing are required; and for every 1,000 revs. of spindle higher or lower than 7,000, the traveller must vary one size each way.



**Travellers for Dry Doubling.**

For Dry Doubling on spinning section Rings,  
1½ in. and 2 in. dia:—

Counts and Ply of Yarn	Traveller.	Counts and Ply of Yarn.	Traveller.	Counts and Ply of Yarn.	Traveller
4/2	30	52/2	4	100/2	9/0
8/2	25	56/2	3	110/2	11/0
12/2	22	60/2	2	120/2	14/0
16/2	20	64/2	1	130/2	16/0
20/2	18	68/2	1/0	16/3	30
24/2	15	72/2	2/0	20/3	27
28/2	14	76/6	3/0	30/3	21
32/2	13	80/2	4/0	40/3	14
36/2	12	84/2	5/0	16/4	40
40/2	10	88/2	6/0	20/4	35
44/2	8	92/2	7/0	30/4	38
48/2	6	96/2	8/0	40/4	20

**Travellers for Two Doublings.**

For *Two* Doublings:—

Counts.....	16/9	20/9	30/9				
1st Doubling.....	14	15	17	traveller.			
2nd „ .....	7	8	10	„			
Counts .....	14/4	16/4	20/4	22/4	28/4	30/4	
Traveller ...	9	10	11	12	13	14	
Counts .....	20/3	22/3	24/3	26/3	30/3	36/3	40/3
Traveller ...	16	16	16	17	17	18	18
Counts .....	30/2	36/2	40/2	50/2	60/2	80/2	100/2
Traveller ...	18	19	19	20	21	21	22

**Four-fold Preventer.**—Consists of a brass rod carrying a curled wire, through which the yarn passes. It is so balanced that, when a thread breaks, the curled wire falls towards the rollers, carrying the yarn with it, and making it impossible for the broken thread to lash itself round its neighbour.

### SELF-ACTING TWINERS.

**Description.**—There are two kinds of twiners in common use, known respectively as the "English" and "French" systems. In the former the spindle rails remain stationary, and the creel containing the bobbins or cops moves in and out. In the latter, the creel is stationary and the carriage travels in and out. Both systems can be arranged for either wet or dry doubling.



**Feeding.**—Receives the spun yarn in cops or bobbins, twists two or more threads together, and delivers the yarn in the form of cops.

**Pulleys.**—16 in. dia.  $\times$  5 in. wide.

**Speeds.**—Spindles 7,000 to 9,000 revs. per minute, according to counts of yarn doubled.

**Power.**—English system, 200 spindles per I.H.P.

French system, 150 spindles per I.H.P.

**Production.**—40/2 fold,  $1\frac{1}{4}$  lb. per spindle.

**Floor Space.**—For *Length*:—Multiply the number of spindles in mule by spindle gauge and add space taken up by headstock and frame ends, viz.: 52 in. to 62 in., according to maker. For *Width*:—A pair of twiners of 70 in. stretch take up 20 ft.

**Piecing Doubled Yarn.**—Piecing the ends of doubled yarn may be effected by either tying or by splicing. The best results, however, are obtained by using the "Balfe" splicing machine, which is of great service when starting a new set of bobbins, etc. When the ends are simply twisted into each other, they are liable to produce bulky joinings.

### DOUBLING-WINDING

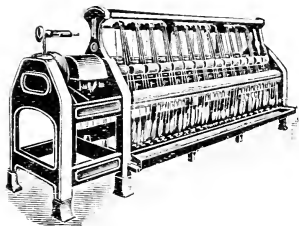

**Function.**—To wind several threads together without putting twist in. The winding may be from any convenient number of cops, or ring bobbins on tubes of wood or paper. The yarn is usually wound in the form of cheeses, or large cops.

**Types.**—(1) Machines with the traverse obtained by means of diagonally split drums.

(2) Machines having the rod for the traverse guide worked from a cam at the end of the frame.

(3) Machines in which the spindle and its connections are entirely self-contained.

(1) **Split Drum Winders.**—These are of the simplest form, and are well adapted for winding coarse yarns at high speeds. They are made with and without stop motions.

**Speed.**—Varying according to quality of yarn wound.

**Pulleys.**—12 in. dia.

**Power.**—Single-end machine, 120 drums, = 1 I.H.P.  
Stop motion winder, 70 drums, = 1 I.H.P. Winding from cops or bobbins.

**Production.**—From 200 to 300 yards per minute, according to the quality of yarn and number of threads put up.

**Length.**—Gauge ( $8\frac{3}{4}$ )  $\times$  one-half the number of drums + 20 in. for gearing and off end.

**Width.**—4 ft. 5 in. when winding from end of cops or bobbins; 3 ft. 10 in. when winding from hanks.

The use of these machines can be extended to the winding of fine yarns by the adoption of a patented Tension Regulator, which consists of a double-pointed cam inserted inside each drum, against the surface of which the yarn rests on its way to the spool. The points of the cam represent its largest diameter, and come into contact with the yarn when it is about midway across the drum, thus taking up the slack, which at this period is the greatest. When the yarn is passing through the slit at the side of the drum, it passes over the small diameter of the cam, which in turn gives off the length of yarn required to compensate for the increased tension that would otherwise occur.

Under these improved conditions the machine may be worked at the following speeds:—

				Revs. per min.
For Counts (say)	8's and 10's	two-fold,	pulley about	300
„	20's	„	„	400
„	40's	„	„	450
„	60's & 80's	„	„	500
„	90's	„	„	550
„	100's & upwards	„	„	600-700

(2) **Thread Guide Winder.**—Winds any number of threads up to six upon cheeses, either conical or parallel. The length of traverse may be from 3 in. up to 6 in. and the diameter of the cheeses up to 6 in. Cops, hanks, or bobbins may be put up to wind from. Stop motions are provided which come into action immediately a thread breaks.

**Speed.**—600 revs. or 160 yards per min.

**Pulleys.**—10 in. dia. × 3 in. wide.

**Power.**—120 drums = 1 I.H.P.

**Production.**—30/2 fold; 104 hanks in ten hours.

**Length.**—Gauge + 2 in. × half the number of drums and 3 ft. 4 in. for gearing, etc.

**Width.**—3 ft. 2 in.

(3) **Self-Contained Winder.**— This type of machine differs from the ordinary quick traverse winder in that each spindle and its connections constitute a separate head; though several heads may be put together to form one frame. Each head is provided with an independent stop-motion which arrests the spindle when a thread breaks or when a spool is full. In the process of winding the thread runs over a guide in a straight line direct from the cop or bobbin to the tube. The coils are laid side by side, touching each other but without overlapping or riding. The cheeses may be either conical or parallel and of sizes varying from the smallest spools for sewing machine shuttles to others weighing as much as 50 lb.

Will wind any number of threads up to 12 in one operation. To increase this number a second machine is used, which takes in 5 spools from above and winds the threads they contain upon the tube. Thus, in the case of 12 ends up, the number of threads on this tube will be 60.

**Speeds.**— Spindles 1,000 to 2,000 revs. per minute, according to size of spools and class of yarn wound.

**Pulleys.**—3½ in. dia.      **Power.**—½ I.H.P. per head.

**Production.**—20's to 30's average 1 lb. per spindle per hour.

**Floor Space.**—4 ft. 8 in. long × 1 ft. 8 in. back to front.



## THREAD KNOTTERS.



**Function.**—To piece-up broken threads during the winding and rewinding of yarn.

**Description.**—The implement is held in the left hand of the operator, who passes the two broken threads together over a small guide. By pressing the thumb towards the palm of the hand, the knot is tied; and on the reverse movement the projecting ends are cut off short, so as to present no obstruction in subsequent processes.

Other devices are available for this purpose, which are less costly, but they require more manipulation by the operator.

## GASSING

### GASSING OR CLEARING YARN.

**Function.**—To remove the projecting and loose fibres adherent to the surface of the yarn, and thus render it smooth and round. Yarn so treated is suitable for use in the manufacture of sewing thread and lace; also for mercerising, etc.

#### Frames with Horizontal Burners.

**Description.**— These machines are usually worked on the quick-traverse principle. The yarn as it is gassed is wound upon wooden or paper tubes in the form of spools, which can be reeled off endways. The yarn is passed repeatedly through a series of Bunsen gas flames, at a great speed.

The burners used are made in various forms, either atmospheric or plain, and with the flames rising from slits or from a series of holes. It is an advantage if the burners have detachable tops, as these provide better facilities for cleaning.

**Pulley.**—12 in. dia. Single frame, 120 revs. per min. Double frame, 150 revs. per min.

**Power.**—About 80 drums per 1 I.H.P.

**Floor Space.**—Half number of drums in frame  $\times$  gauge + gearing and off-end space (usually about 2 ft. 7½ inches).

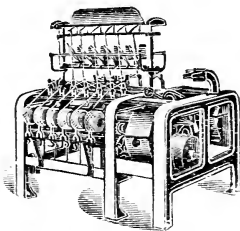

**Productions.—**

Counts	Revs. of Drum Shaft per minute	No. of times through Light	Hanks per Drum in 10 hours	Lbs. per Drum in 10 hours	Hanks per Drum per week of 56½ hours
30's 2-fold	100	9 to 11	43·18	2·878	244
40 "	100	9 to 11	43·18	2·159	244
50 "	100	9 to 11	43·18	1·727	244
60 "	110	9 to 11	47·43	1·584	268
70 "	110	9 to 11	47·43	1·355	268
80 "	110	9 to 11	47·43	1·185	268
90 "	110	9 to 11	47·43	1·054	268
100 "	110	9 to 11	47·43	0·948	268
110 "	120	9 to 11	51·85	0·942	293
120 "	120	7	51·85	0·864	293

**Frames with Vertical Burners.**

**Description.**—These frames are made with the Bunsen burners high up in the frame and encased in a split tube, through which the yarn passes. By this system the yarn encounters the flame once only, and the machine can be run at exceptionally high speeds. Split drums impart the necessary traverse to the yarn in forming the spool. This system is well adapted to the use of ventilating or exhausting installations for carrying off the gas fumes.

**Approximate Speeds:—**

For 8's and 10's two-fold yarn,	pulley 300	revs per min.
„ 20's and 30's	„ „ „ 400	„ „
„ 40's and 50's	„ „ „ 450	„ „
„ 60's and 80's	„ „ „ 500	„ „
„ 90's and 100's	„ „ „ 550	„ „
„ 110's and upwds.	„ „ 600 to 700	„ „

(Pulley 7 inches diameter.)

It is an advantage to have gassing frames provided with water gauges, so that each attendant can see at a glance the pressure of gas, and regulate the supply accordingly.

Yarn passed through a gassing frame is slightly reduced in diameter; and when a definite count is required allowance should be made for this reduction.

The cost of gassing yarn may be greatly reduced by mixing air with the gas in suitable proportions, and

supplying the mixture to the machines under a pressure to be determined by the user.

An apparatus for this purpose consists of two positive blowers—one for air and one for gas—geared together in the desired proportions and driven by a variable drive, which is governed automatically to give a predetermined pressure in the tanks. The speed of the engine, atmospheric conditions, and pressure in gas main have no effect in altering the mixture or pressure. The amount of gassing required is regulated by the pressure in the pipes.

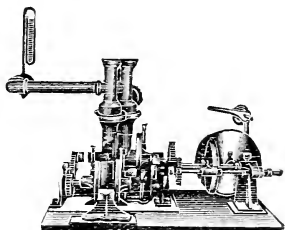

## REELING

When yarn has to undergo, before weaving, the process of bleaching, dyeing, etc., it is generally reeled into hanks of any convenient size. When intended for **export**, such hanks generally are of the standard measurement of 840 yards.

**Cross Reeling.**—This is the cheapest system, and causes the least waste. The yarn is more easily wound to the bobbin, and broken threads easily discovered.

**Figure 8 Tie.**—Hanks for bleaching and dyeing generally have an extra band at the opposite end of the hank from the lease band, to keep the threads straight during the process. This band is tied in the form of the figure 8: hence its name.

**Diamond or "Grant" Reeling.**—This is a system of cross-reeling which admits of larger lengths being reeled without the danger of entanglement. The diagonal crossings are so open that the tie can be easily threaded in-and-out, which is a great advantage when reeling expensive yarns. There is less waste, and greater production is obtainable in winding-off.

**Straight or Lea Reeling.**—Is mostly adopted in the case of yarn for export. The threads are laid side by side, and each hank is divided by ties into 7 leas of 120 yards = 840 yards.

**Ring Tie System.**—Is adopted when the yarn is built up of skeins, and also when the hank is undivided and

a movable tie is required for convenience in polishing. The ends of the hank are tied to one another, and the band is passed round to hold the threads together.

### REELING MACHINES.

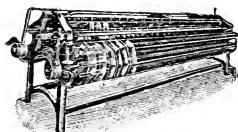

**Function.**—Winds the yarn into hanks for dyeing, bleaching, bundling, etc., from cops or ring or doubler bobbins.

**Types.**—Single, *i.e.*, one swift only. Double, *i.e.*, two swifts, one on either side.

**Description.**—In reeling from cops or ring bobbins the yarn is generally taken from the "nose." But in the case of doubler bobbins, the latter are mounted upon revolving spindles, and the yarn is taken off the side. These machines are also made to wind from "cheeses."

**Driving Pulleys.**—8 in. diameter  $\times$   $1\frac{1}{2}$  in. on face.

**Speed.**—250 revs. per min. from Cheeses, Ring Frame Bobbins, and Cops, endways.

„ 160 revs. per min. from Ring Doubler Bobbins, sideways.

**Production.**—Reeling from Cheeses, Ring Frame Bobbins, and Cops, 4,500 to 5,000 hanks per 10 hours.

„ Reeling from Ring Doubler Bobbins, 3,000 hanks per 10 hours.

**Power.**—1 H.P. for 8 reels.

**Attendance.**—2 girls to 1 double reel.

----

**Thread-holder and Cutter for Reels.**—This is a small device, made of stamped steel, one side of which is bent at right angles to the shape of a knife-blade, the other portion being flat. It is fixed between every two hanks on the inside of any one pair of staves, which close up together when doffing. Its object is to dispense with wrapping the thread round the stave, or twisting it round a peg. The thread is simply placed under the holder, and so held until doffing takes place, when the thread is severed by passing under the edge of the blade.



## PREPARING GREY YARNS.

This operation is a process of calendering, which imparts a lustre or glazed appearance to the yarn, similar to that of linen thread.

Yarn selected for preparation should by preference be cross-reeled, because it is more readily spread upon the rollers. When reeled on the 7-lea principle, the band separating the leas is liable to cut the yarn while it is under the pressure of the rollers.

Prepared yarn is generally shipped without undergoing any further process.

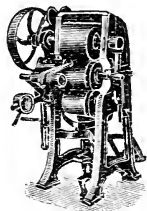

### PREPARING MACHINE.

**Function.**—Receives the yarn in the hank from a cross-reeling machine, and imparts the necessary lustre thereto by means of rollers.

**Description.**—The yarn is spread evenly over two rollers working inside the hanks. One of these rollers is supported in a swivel bearing, and the other by a weighted lever arrangement. This latter can be moved outwards for the purpose of putting the required tension upon the hanks. A third roller rests heavily upon the swivel roller, and a fourth works in a similar manner against the under side, the pressure in this case being obtained by means of a movable weighted lever. The swivel roller (which is usually made of compressed paper) is turned outwards when the hanks of yarn are being removed or replaced. The tension roller is provided with a crossing motion, which distributes the threads and insures uniformity of treatment.

Cocoa-nut oil or fat is sometimes applied at intervals to the compressed paper roller. This operation is usually done by hand, but if the grease be applied in irregular quantities there is danger of causing streaky and otherwise faulty hanks. An arrangement has recently been devised which deposits the grease automatically in regular and minute quantities, and which can be regulated to suit the speed at which the machine works.

**Pulleys and Speed.**—24 in. dia., 20 revs. per minute.

**Power.**— $1\frac{1}{2}$  to 2 I.H.P.

**Production.**—According to finish.

**Floor Space.**—5 ft. 4 in.  $\times$  3 ft. 0 in.

DAMAGED HANKS and broken threads are caused by the attendant bringing the weight to bear too suddenly upon

the bottom roller, and can be avoided by recent improvements:—

(1) By means of a "free-wheel" arrangement, in which the bottom roller is driven by the top roller, while the intermediate or cotton roller runs free; and by means of pinions of suitable diameter there is given to the bottom roller, before it comes in contact with the yarn, a slightly less speed than it will have when it comes to be driven by friction from the intermediate roller. At this point its speed increases very gradually, and the catch motion of the free wheel begins to work. The operation of preparing the yarn then continues as in the old machine.

(2) By the application of a rolling weight, which moves gradually along the weight lever until the machine has assumed its normal speed.

One girl will mind about two machines; but, if crossing motions are applied, she may have charge of four machines.

## BUNDLING

**Single yarns** are generally made up in 10 lb. bundles, either long or pressed. The former are mostly used for the home trade, and when the yarn is intended for bleaching, dyeing, etc.

*Long Bundles.*—Usually consist of 20 hanks divided into two parts by a halch band, and twisted together inwardly to form a knot. A quantity of these knots, sufficient to make a bundle of 10 lb., are tied together the full length, either by twine or by hanks from the bundle. The bundles are then about 26 inches long, and are usually delivered without paper wrapping. A ticket number should be placed on each bundle to indicate the counts.

*Pressed Bundles.*—Are made up of a series of knots of 10 hanks each, which are hung on a bar or hook and twisted; then doubled ready for fixing in the press. The heads of each knot are placed at one end of the press, to form the face of the bundle. The machine having been charged, and the pressure put on, the bundle is tied up and the pressure is released. (Cotton twine is best for tying purposes, as it is not liable to mildew.) After wrapping with paper, the bundles should be stamped with the counts. For further protection, the bundles should be provided top and bottom with cardboard.

In pressed bundles it is usual for the number of knots to correspond with the counts of yarn bundled, so that whatever the counts pressed, the weight of the bundle is the same. The basis of a 10 lb. bundle is 1's counts. Thus if a bundle contain 20 hanks of 20's (which equal 1 lb.), and there are 10 hanks in a knot and 10 lb. in a bundle, the number of heads in the bundle represent the counts.

In making up **doubled yarn**, the number of heads multiplied by the fold in doubling gives the counts. Thus:—Two-fold 20's would show ten heads, and three-fold 36's twelve heads, etc. On this principle a knot of folded yarn is the same length as a knot of single; but this rule is not always applied.

*Sewing Cotton* is made up in skeins and marked. For instance, a 10 lb. bundle marked 2/12's 90 × 40 would represent a bundle containing 90 hanks, each hank having 40 skeins of two-fold 12's yarn. The weight of the bundles varies according to the requirements of the market. So does that also of those containing knitting yarn.

*Reverse Cable Yarns* are generally made up in 5 lb. bundles. The hanks are continuous, and the head of each appears at the face of the bundle, upon which is marked the counts and folds of yarn.

### THE BUNDLING PRESS.

**Function.**—Makes up the hank yarns into bundles of a given weight, and presses them so that they may be packed in small compass for transit.

**Description.**—The press is generally provided with a table mounted upon very strong framing. The bundling is effected by means of two sets of vertical bars, arranged side by side opposite each other. To one set a further set of bars are hinged. When the machine has been charged with yarn, the hinged bars are brought over and the ends are interlocked with the first set of bars. The pressure required is then brought to bear upon the bundles underneath. When the strings have been tied the pressure is released, the hinged bars are raised, and the bundle is removed to the packer.



**Speeds.**—60 revs. per min.

**Pulley.**—24 in. dia., with a 3 in. belt.

**Power.**—1 I.H.P.

**Production.**—With one man and two junior assistants to do the knotting, average counts 20's.....200 bundles of 10 lb. each (or equivalent) per day of 10 hours.

**Floor Space.**—3 ft. 0 in. × 2 ft. 0 in.

### Installation

OF 5,040 SPINDLES FOR DOUBLING AND GASSING 2/60's YARN,  
TO BE SOLD IN BUNDLES.

2 Quick-Traversal Drum Winding Frames, 130 drums each.

10 Ring Doubling Frames, 504 spindles each.

2 Winding Frames to wind on single-flanged bobbins,  
200 spindles each.

4 Gassing Frames on quick-traverse principle, 148 drums  
each.

6 Double Reels, 40 hanks each.

1 Bundling Press.

If the yarn be not gassed but bundled only, then omit the 4 gassing frames.

The above plant would deal with about 5,000 lb. of yarn.

## THREAD, LACE, HOSIERY, AND NEPPED YARNS

### SEWING THREAD: PROCESSES.

**Sewing Cotton** generally undergoes two twistings if the yarn doubled be more than three-fold. In the first doubling, the yarn is twisted in the same direction as that in which it is spun; but in the second, or finishing doubling, the direction of the twisting is opposite to that of the spinning. Two or three-fold sewing cotton is twisted once only, and the twist is in the opposite way from that of the spinning.



In manufacturing sewing thread in the warp, after it has been doubled in (say) three-fold or six-fold, or doubled for crochet purposes, it is usually wound on to warpers' bobbins. From 100 to 360 of these bobbins are placed in a creel, and the yarn thereon is either wound upon beams or is linked into chains, according to requirement. The threads are leased at distances to prevent them from becoming entangled during the dyeing or bleaching.

If the thread is to be treated in the hank, it is reeled directly from the doubler bobbins, or is first cleared in a clearing frame and then reeled.



### Dyeing and Bleaching.

From the machines above named, the thread is taken to be dyed or bleached. When it is to be dyed black or a dark colour, it is (as a rule) not bleached, but merely boiled with water until thoroughly softened or wetted. It is then taken to the dyeing machine.

For light colours the thread is sometimes passed through a weak boiling solution of soda ash, then steeped for a few hours in a weak cold solution of chloride of lime; afterwards it is washed in water, steeped in dilute hydrochloric acid, and finally well washed.

### Bleaching.

In bleaching proper, the material is subjected to the following operations:—

(1) It is boiled for six hours in caustic soda and water, then steeped in water, and finally washed.

(2) The thread is put through the chemicking process by being steeped for two hours in a solution of bleaching powder, then washed well to prepare it for the souring.

(3) In souring, the thread is steeped half-an-hour in dilute sulphuric acid, then washed for half-an-hour, and finally passed through a washing machine. Owing to the close texture of sewing thread, these operations may be repeated with advantage, to ensure a pure white.

(4) When the thread is to be finished in the white, it is run through a dumping machine, containing a hot soap solution and ultramarine blue, then through a hydro-extractor and dried.

## MACHINES USED IN MANUFACTURING SEWING COTTON SIX-FOLD IN THE WARP

(Bleached & Dyed).

### Stop Motion Winder.

Winds the yarn from the spun cops or bobbins two-fold on to cheeses or doubler bobbins.

Speed.—About 60 revs.

Pulleys.—12 in. dia.

### Doubling Twister.

(Either ring or flyer system.) Takes the doubled yarn from above frame and twists the strands together in the same direction as that in which they were spun.

**Clearing Frame.**

Removes from the yarn all lumps and extending ends before receiving the second twisting.

**Speed.**—140 revs. per min.      **Pulleys.**—12 in. dia.

**Doubling Twister.**

(Either ring or flyer.) Takes three of the strands above twisted, and imparts the final doubling to form six-fold thread. The twist put in by this machine is in the direction opposite to that in which the yarn has been spun.

**Winding Machine.**

Winds the thread from the doubler bobbins on to warpers' bobbins, for the chaining and linking machine or for the beaming machine.

**Speed.**—140 revs. per min.      **Pulleys.**—12 in. dia.

**Chaining and Linking Machine.**

Forms the twisted threads into a chain, then links them into bags or baskets ready for bleaching or dyeing. These machines save the expense of beam warping, are automatic, and have a stop-motion to arrest the machine when a thread breaks.

**Speed.**—125 revs. per min.      **Pulleys.**—10 in. by 3 in.

**Floor Space.**—7 ft. 3 in. by 6 ft.      **Power.**— $\frac{1}{2}$  I.H.P.

**Vomiter Boiler.**

The thread (in the form of chain) is laid closely in the chamber of this machine, and is subjected to a boiling process in caustic soda and water for about four hours.

**Floor Space.**—6 ft. by 6 ft.

**Bleaching Kier.**

The chain of thread from the above machine passes over winches into a bleaching kier, on one side of which is a well containing the chlorine or bleaching mixture, and on the other side a well of sulphuric acid for the souring. The kier having been charged, the liquid from the first tank is passed through the contents, after which the latter are well washed. The souring process next follows; it is effected by pumping the liquid from the second well, and washing again follows.

**Washing Machine.**

Is indispensable after bleaching, and is used to give the material a thorough washing before going to the dumping machine.

**Speed.**—110 revs.      **Pulleys.**—12 in. by 2 in.

**Dumping Machine.**

Is used to impart a uniform finish to the thread and equalise the effects of the previous processes.

**Speed.**—50 revs.

**Pulleys.**—30 in. by 3½ in.

**Soaping and Blueing Machine.**

Is provided with a large chamber and squeezing-rollers, through which the thread is passed to receive the necessary tint or finish.

**Speed.**—100 revs.

**Pulleys.**—12 in.

**Hydro-Extractor.**

This receives the bleached yarn, and extracts therefrom as much as possible of the liquid.

**Drying Machine.**

Is usually made with seven or nine steam-heated cylinders, so arranged that the thread passes under and over the surface of each, and is completely dried. From this machine the thread is wound again on to flanged beams for polishing. The warp passes over the cylinders at about 190 ft. per minute.

**Speed.**—100 revs.

**Pulleys.**—18 in. by 5 in.

To complete the above installation it is necessary to provide the following:—

Tank in which to mix the chlorine.

Stirrer for the polishing mixture.

Tank for the caustic soda.

**Polishing Machine.**

The beams containing the doubled warp threads are placed behind this machine, and the threads thereon are passed through a trough containing the necessary polishing mixture. After passing through a pair of squeezing rollers, the threads are brushed by cylindrical brushes, after which they are wound upon bobbins to be taken to the spooling machine. There are usually two brushes and one beater, or (in some cases) 3 single brush rollers. The creels are arranged to suit the number of ends or strands in the chain.

**Speed.**—650 revs. per min. **Pulleys.**—14 in. by 4 in.

**Power.** -2 I.H.P. **Floor Space.**—26 ft. by 5 ft. 6 in.

**Production.**—200 lb. per 10 hours.

**Automatic Spooling Machine.**

These machines are usually made with 10 heads, and are adapted for dealing with large quantities of thread of one counts and length, and are both expeditious and economical.

**Speed.**—280 revs. per min.      **Pulleys.**—14 in. by 3 in.

**Floor Space.**—14 ft. by 3 ft.

**Production.**—36 gross of 200 yard spools per day.

When the thread is of a varied kind, and in the case of dealing with smaller quantities, the machines used are generally on the hand and semi-automatic principle.

**HANK SYSTEM.**

When the doubled yarn is to be treated in the hank, the hanks are tied loosely together, so as to form a continuous link chain for passing through the bleaching range, the treatment being practically the same until the polishing process is reached.

**Polishing Machine.**

This is worked on the upright principle, and takes in 54 hanks. The brush cylinder is usually 2 ft. 2 in. wide, and has from 10 to 30 brushes, according to the size of the machine.

**Speed.**—350 revs. per min.      **Pulleys.**—14 in. by 3 $\frac{3}{4}$  in.

**Winding Machine.**

Winds the yarn from hanks on to bobbins. Is worked on the drum principle, containing from 30 to 100 drums.

**Spooling Machine.**

The finished thread is spooled on the machine above described.

**SOFT OR UNGLAZED THREAD.**

When the warp threads, handled as above, have to be spooled in the soft or unglazed state, the beams containing the doubled yarn are taken directly to a "beam or bobbin" winding machine.

**Winding Machine for Warp.**

These machines usually contain 300 spindles, and wind on to bobbins, with a 5 in. or 6 in. traverse, as required.

**Speed.**—100 revs. per min.      **Pulleys.**—12 in. by 4 in.

**Power.**—1 I.H.P.

**Floor Space.**—17 ft. 6 in. by 5 ft. 6 in.

**Winding Machine for Hanks.**

Is on the drum principle, and usually contains about 100 drums.

Speed.—240 revs. per min. Pulleys.—12 in. by 3 in.

Power.—2 I.H.P. Floor Space.—34 ft. by 6 ft.

**Spooling Machine.**

Particulars as above.

**TICKET NUMBERS AND YARN COUNTS.**

2 Cord Ticket Nos.	Yarn Nos.	3 Cord Ticket Nos.	Yarn Nos.	4 Cord Ticket Nos.	Yarn Nos.	6 Cord Ticket Nos.	Yarn Nos.
20	) — 20	10	) — 20	10	) — 24	10	) — 36
24		12		12		12	
30	) — 24	16	) — 22	14	) — 28	14	) — 40
36		20		16		16	
40	) — 28	24	) — 26	18	) — 32	18	) — 46
50		30		20		20	
60	) — 36	40	) — 40	24	) — 36	24	) — 50
70		50		30		30	
80	) — 40	50	) — 50	36	) — 46	36	) — 70
80		60		40		36	
90	) — 46	70	) — 60	40	) — 50	40	) — 80
90		80		50		40	
100	) — 50	80	) — 70	50	) — 60	50	) — 100
		90		60		50	
		90	) — 90	60	) — 70	60	) — 110
		100		70		70	
		120	) — 100	80	) — 80	80	) — 120
				90		80	
			) — 90	100	) — 90	90	) — 130
				110		110	
			) — 100	120	) — 100		
				130			
			) — 110	140	) — 110		
				150			
			) — 120	160	) — 120		
				170			
			) — 130	180	) — 130		

### STRENGTHS OF DOUBLED YARN.

The following are the average breaking strengths of 6/cord yarn for thread:—

Counts.	Fold.	Lb.
32 .....	6 .....	11.6
36 .....	6 .....	9.2
40 .....	6 .....	8.13
46 .....	6 .....	7.5
50 .....	6 .....	7.3
60 .....	6 .....	6.6
70 .....	6 .....	5.8
80 .....	6 .....	5.5
100 .....	6 .....	4.5
110 .....	6 .....	4.1
120 .....	6 .....	3.8

### CROCHET AND LACE YARNS.

**Crochet Cotton** is doubled twice, but the first doubling is in the opposite direction from that in which the yarn has been spun, while the second doubling is in the same direction. In other words—The twisting for crochet yarn is in the opposite direction from that of sewing cotton.



The quality and strength of the above products are determined by the quality of the spun yarn and the number of strands twisted together.

**Lace Yarns.**—Doubled yarn for use as warp is invariably weft, spun twist way but doubled weft way. Two or more threads are first wound from the cops on to cheeses or bobbins. After doubling, the yarn is cleared and (if necessary) gassed. It is then finally made into balls, chains, or beams, for delivery to the user. Doubled weft for bundling is first wound as above, then twisted on the doubler, and finally reeled into hanks for the preparing and finishing machines.

### DYEING.

#### Chain or Warp-Dyeing Machine.

The chain of thread enters the machine at one end of the box containing the dye, by passing over a set of carrier rollers. The delivery end is provided with a pair of adjustable squeezing rollers.

Speed.—40 revs. per min.

Pulleys.—16 in. by 4 in.

Floor Space.—12 ft. by 4 ft. 8 in.

### " NEPPED " YARN.

The " neps " required in the production of " nepped " yarn are first prepared on an ordinary roller-and-clearer carding engine, with the following alterations:—The casing under the taker-in is plain. The fancy roller usually employed is done away with, as are also the casing under the cylinder and the stripping comb and doffer. The coilers and sides of the coiler covers, and the covers at the sides and ends of the machine framing, are no longer necessary. The laps put up at the machine are of the ordinary kind, taken from the scutcher.

**Setting.**—The setting of the card governs the size of the neps made: that is to say, the closer the setting, the smaller the neps. For ordinary purposes the setting should be two gauges thick.

**Wire.**—Cylinder, 40's. Doffer and rollers, 80's. All needle-pointed. Licker-in has saw-tooth clothing.

**Speed.**—Cylinder, 170 revs. per minute.

The centrifugal force of the cylinder in revolving throws the neps of cotton outwards, and as they fall they are deposited into a trough provided for the purpose and placed on the floor underneath the cylinder.

A second machine is employed for carding the plain cotton along with the neps. It is also of the roller-and-clearer type, and is provided with an apron-feed. The lattice for the feed is covered with a closely woven fabric. To prevent the neps from falling through the machine, the casing under the cylinder and the taker-in are made blank. Ordinary scutcher laps are fed to the machine, and are placed between guides, the neps being fed on the lattice behind the roller lap. The neps and plain cotton are fed to the machine in equal quantities; and to ensure the correct proportions the lattice for receiving the neps is marked every 36 inches.

**Drawing.**—The sliver from this machine is put up at the draw frame along with plain slivers from other cards, the proportion being 5 plain to 1 nepped sliver. Care should be taken to have the latter the same weight per yard. The slivers pass through the draw frame to ensure the right doubling. The above proportions may be varied from two to four or three to three, according to the number of neps required.

**Speeds.**—The finished slivers are put up at the slubbing frame in the usual manner, followed by intermediate and

roving frames. In each machine the spindle speed is a little quicker than usual, to ensure sufficient twist being put into the rove for carrying the neps through.

**Spinning.**—On the ring principle. Also the spindles in the frames have a slightly increased speed.

The above arrangement may be varied by placing a plain sliver and a nepped sliver in the creel, and running them together. In this case the proportion of neps would be reduced by one half.

**Counts.**—Nepped yarn is generally spun in counts ranging from 16's to 30's. Ordinary numbers in "travellers" are used.

### DOUBLE TWISTED YARN.

This yarn is often used in place of two-fold single, chiefly in the manufacture of lace. The yarn for double twisting is usually of fine or medium fine counts, soft, spun weft-way on the mule. It possesses almost the strength and appearance of double thread. After leaving the mule, the yarn is wound on bobbins or cheeses. It then receives its second twisting—on a wet doubler. The yarn, being first spun weft-way, resembles two-fold in appearance, inasmuch as the latter is first spun twist-way and doubled in the reverse direction.

Sometimes this yarn is put through a clearing frame, both before and after it receives the extra twist in the doubling frame.

60's double twisted yarn is used instead of 120's two-fold.

65's	"	"	"	"	"	130's	"
70's	"	"	"	"	"	140's	"

and so on.



SECTION V:

COTTON WASTE

WADDING AND BANDING

MACHINERY

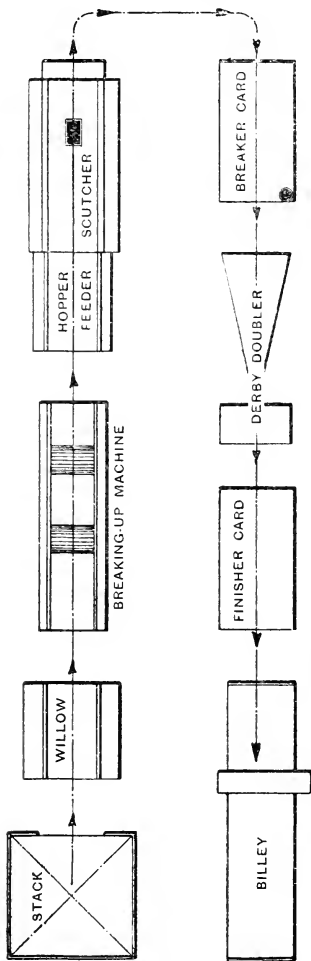

SEQUENCE OF MACHINES FOR OPENING, PREPARING, AND SPINNING  
COTTON WASTE.

## COTTON WASTE

---

The waste given off at the different stages of preparing and spinning cotton may be utilised in a variety of ways. When properly opened it may in its loose state be converted into wadding, gun cotton, etc. Or it may be respun, and manufactured into sheetings, flannelettes, towels, and quilts. When used for the above purposes it is usually classified as follows:—

**SOFT WASTE.**—Made up of flat strips, roller lappings, scutcher droppings, and cardroom waste generally. It is in general demand for west, to be used in weaving cloth having a full body.

**HARD WASTE.**—Originates in the spinning room, and is composed of cop bottoms, ring frame waste, etc. The commercial value of this is considerably less than that of soft waste, on account of the twist it contains; and the operation of disintegrating the fibres is so severe that the staple of the cotton is more or less injured.

Owing to the introduction of new machinery, the waste made in the cardroom may now be utilised with advantage in the mill in which it is made.

**Flat Strips.**—By using a special series of machines, something like 50 per cent. of good cotton may be recovered from the card strips made in a mill spinning American cotton. These machines comprise:—

Combined Opener and Scutcher.

Revolving Flat Carding Engine.

Drawing Frame with 1 head only.

Sliver Lap Machine.

Comber worked on the "Nasmith" or "Whitin" principles.

The good cotton from the comber is taken in the form of sliver and put up at the finishing heads of the ordinary draw frames, in the proportion of 1 to 5 in a frame of six ends up.

**Roving Waste.**—Although of good quality, this waste has undergone a slight twisting, and is therefore not in a fit condition for mixing with that from the card and

draw frames. Nevertheless, it is much too good to go with spinning-room waste. If the waste be passed through one of the mill scutchers along with the opened cotton, the twisted portions are liable to make their appearance in the subsequent processes on account of their stringy condition. The best result is obtained by employing a Roving Waste Opener, which is a special machine designed for the purpose. A full description of this machine is given on page 67.

## HARD WASTE MACHINERY.

### Preparing Machine.

**Function.**—In addition to loosening the waste, this machine exerts a combing action upon the material, and is specially adapted for dealing with that taken from ring-frame bobbins.

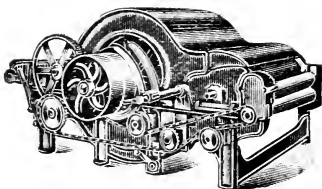

**Description.**— Is provided with a large iron cylinder covered with lags, in which are inserted strong steel teeth; an iron doffer also fitted with steel teeth; and a pair of toothed feed-rollers. The material to be opened is fed

by hand on to a lattice creeper, and after passing between the feed-rollers is drawn away by the teeth of the cylinder. The waste is then taken from the cylinder by the teeth of the doffer, which in turn disposes of it to a pair of fluted calender rollers, whence it is discharged in an open condition upon the floor, ready for the breaking-up machine. This machine is sometimes fitted with a lap-forming apparatus.

**Pulleys.**—24 in. dia.

**Speed.**—250 revs. per min.

**Power.**—7 to 8 I.H.P.

**Production.**—60,000 lb. per 56 hours.

The machine described above may also be used in the "engine-cleaning" waste trade. The waste (white or coloured) is first put through the machine and delivered loosely on the floor, after which it is put into a mixing for finishing on an ordinary cleaning waste machine. In this capacity it is known as a "Running-down" Machine.

**WASTE PREPARING MACHINERY.****Breaking-up Machine.**

**Function.**—Opens and breaks up the waste, and delivers the opened cotton in a thick fleece.

**Description.** — The machine is made with one or more cylinders, and each cylinder is fitted with spiked teeth. After leaving the cylinder, the cotton is thrown upon revolving cages, formed of cross-woven wire. As the cotton leaves each cylinder, the cage conveys the material to the nip of the next pair of feed-rollers, and thence to the succeeding cylinder for the operation to be repeated.

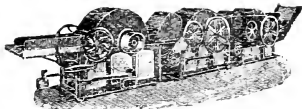

**Feeding.**—The cotton to be opened is distributed loosely upon a lattice creeper, and delivered to the cylinder by passing between a pair of weighted and fluted feed-rollers.

**Pulleys.**— 12 in.  $\times$  6 in. for one cylinder machine; 12 in.  $\times$  8 in. when one belt drives two cylinders combined by side rope drive.

**Speed.**—800 revs. per min.

**Power.**—One-cylinder machine 3 to 5 I.H.P., others additional in proportion.

**Floor Space.**—One-cylinder machine, 9 ft. 3 in.  $\times$  4 ft. 9 in.; two-cylinder machine, 15 ft. 10 in.  $\times$  4 ft. 9 in.; three-cylinder machine, 22 ft. 5 in.  $\times$  4 ft. 9 in. Add 6 ft. 7 in. for each additional cylinder. (If with Soaping Apparatus, add 3 ft. 8 in.)

**Scutcher.**

**Function.**—To clean the cotton, and form it into laps of uniform weight and density, ready for putting-up at the Breaker Carding Engine.

**Description.**—Has one cylinder and one beater only, and is provided with lattice creeper feed; or may have hopper feeder attached. In other respects the machine is practically the same as those used for ordinary cotton. See previous notes, Section III.

**Carding Engine (Breaker).**

**Description.** — Is on the roller and clearer principle, and usually made with a cylinder 50 in. dia. and 48 in. wide on the wire surface. The doffer is 22 in. to

26 in. dia., and there are usually 7 or 8 rollers, and six clearers, and one fancy roller.

**Feeding.**—The machine is provided with a lattice creeper for receiving two laps from the scutcher. After passing through the card, the cotton is delivered into the cans in the form of sliver.

**Pulleys.**—18 in.  $\times$  3 $\frac{1}{4}$  in.

**Speed.**—75 to 85 revs. per min.      **Power.**—1 $\frac{1}{2}$  I.H.P.

**Production.**—210 lb. in 10 hours.

**Floor Space.**—11 ft. 6 in.  $\times$  6 ft. 9 in.

### Derby Doubler.

**Function.**—Unites into a sheet a given number of carded slivers, and forms the same into laps for the Finisher Carding Engine.

**Description.**—Is usually arranged to make laps about 23 in. wide, and is provided with a V-shaped feed-table for 60 sliver cans. To each sliver or can there is a motion for stopping the machine when a sliver breaks.

**Feeding.**—The cans from the breaker card are placed on either side of the V-shaped table, and the slivers from the cans are drawn through the machine and formed into laps of a given length.

**Pulleys.**—14 in.  $\times$  3 in.

**Speeds.**—About 120 revs. per min.      **Power.**—1 I.H.P.

**Production.**—1,500 lb. per 10 hours.

**Floor Space.**—14 ft.  $\times$  7 ft. 8 in.

### Carding Engine (Finisher).

**Description.**—Same as the breaker machine, except that the delivery end is provided with a condensing apparatus for reducing the cotton to the form of thread or rove, which is wound upon long flanged bobbins for the mule creel. The doffer is clothed with rings and leather dividers, about  $\frac{1}{2}$  inch wide, which separate the fleece into slivers. These latter vary in number from 26 for 5's counts to 40 for 10's counts. The slivers

are doffed by comb, and pass over a grooved roller on to leather rubbers, which latter, by a combined cross and

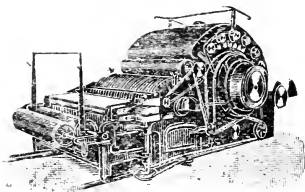

forward movement, reduce the slivers to the thickness of rove for the mule.

**Feeding.**—The laps from the Derby Doubler are placed behind the machine, two or four at a time, each lap consisting of two doubler laps placed side by side.

**Pulleys.**—18 in.  $\times$  3 $\frac{1}{4}$  in.

**Speed.**—75 to 90 revs. per min.      **Power.**—2 I.H.P.

**Production.**—100 to 160 lb. in 10 hours, according to counts.

**Floor Space.**—14 ft.  $\times$  6 ft. 9 in.

### Scotch System.

Instead of employing Derby Doublers (as in the foregoing arrangement), the cotton may be transferred directly from the Breaker to the Finisher Carding Engine, by means of a travelling creeper. This system

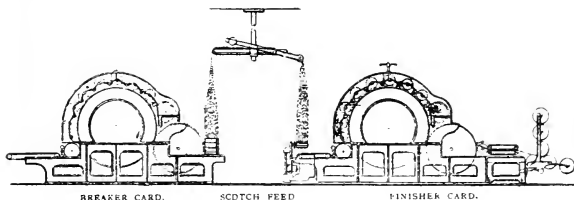

is termed the "Scotch" or "Cross-over" feed, and is more economical both as regards labour and machines. In this arrangement the Finisher Card is usually provided with a ring-doffer divider condenser.

### Mule or "Billy."

**Description.**— — Is somewhat similar to the ordinary self-acting mule, except that the draft is put in the cotton between the rollers and the spindles. It is formed with two lines of bottom and one line of top rollers. The condenser bobbins are placed in inclined stands, and are unwound by surface contact with slowly revolving drums. The rove is delivered from the rollers at a uniform speed throughout the draw, and the speed of the carriage is also uniform, the draft being obtained by the gain of the carriage over the rollers.

**Pulleys.**—16 in.  $\times$  3 in.

**Speed.**—Single, 350 revs. per min.; double, 670 revs. per min.

**Power.**—110 spindles per I.H.P.

**Floor Space.**— — Number of spindles  $\times$  gauge of spindles + 5 ft. 6 in. for headstock and frame ends.

### Productions—

Counts	Gauge	Spindles	Lb. per week
1's .....	$2\frac{3}{4}$ in.	400	6,000
2's .....	$2\frac{3}{4}$ in.	400	4,000
3's .....	$2\frac{3}{4}$ in.	400	3,600
4's .....	$2\frac{1}{2}$ in.	530	3,200
5's .....	$2\frac{1}{2}$ in.	530	2,700
6's .....	$2\frac{1}{2}$ in.	530	2,400
7's .....	$2\frac{1}{2}$ in.	672	2,000
8's .....	$2\frac{1}{2}$ in.	672	1,800
9's .....	$2\frac{1}{2}$ in.	672	1,600

## SOFT WASTE MACHINERY.

### Opening and Cleaning Willow.

**Function.**—Cleans and opens the material, and delivers it in a loose state ready for the second opening.

**Description.**—The feeding and delivery lattices of this machine are driven at a uniform speed, so that the time occupied in the feed and discharge is always

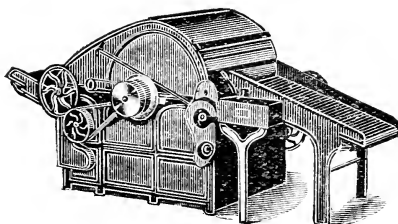

the same; but the feed-rollers are driven intermittently by means of a regulator, so as to allow the charge of



cotton to remain in the machine any predetermined length of time.

**Pulleys.**—14 in.  $\times$  4 in.      **Speed.**—330 revs. per min.

**Power.**—3 I.H.P.      **Production.**—1,700 lb. in 10 hours.

**Floor Space.**—7 ft. 6 in.  $\times$  7 ft. 8 in.

### Waste Shaker.

**Function.**—Shakes out the dirt from opener and scutcher droppings and card waste, without damaging the staple.

**Description.**—Consists of a cylindrical cage or sieve, in which the material is placed. As the cage rotates,

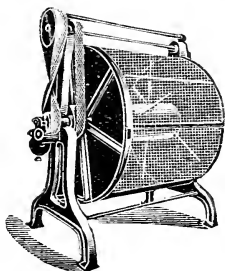

the material is rolled about until all the loose dirt therefrom is deposited through the spaces between the wires of the cage. Little power is required to drive the machine.

### Opener.

**Function.**—To open and further clean the cotton, and prepare it for the scutcher.

**Description.**—Is usually of the vertical beater type, and is provided with a porcupine feed with lattice creeper. The opened cotton passes from the beater to a perforated cage, whence it is stripped, and deposited on to the floor. For further particulars see notes, Section III.

**Scutcher, Card, and Mule,** as in Hard Waste preparation.

## COTTON WADDING PLANT

After the raw material has been opened and cleaned, it may be manufactured into wadding by either of two systems, namely:—The "long" system and the "short" system.

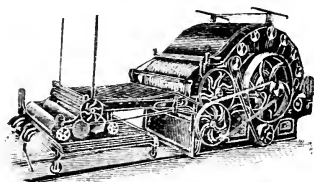

**Long System.**—This is applicable when the material to be dealt with is in sufficient quantities to keep employed a full set of thirteen carding engines. This system also enables the manufacturer to produce wadding having an outer surface of a better material than the interior of the fabric, while the product generally is uniform.

**Short System.**—A fleece of wadding is made separately and completely on one carding engine. This system facilitates the manufacturing of varying qualities and quantities of wadding, to suit circumstances.

### LONG SYSTEM.

**Thirteen Carding Engines**, fed either by hand or lap, and provided with lattice for delivering on to a travelling chain-creeper.

**Power.**—1 I.H.P. per machine.

**Floor Space.**—Machines with lattice—13 ft. 6 in. × 7 ft. 3 in.

**One Travelling Chain Creeper**, with laths 40 in. wide, for accumulating the fleece.

**One Lap-Forming Apparatus**, for making the fleece into laps.

**One Gumming Machine**, with diagonal feeding lattice, gumming roller, and gum or size supply cistern.

**Speed.**—65 revs. per min.

**Pulley.**—18 in.  $\times$  3 in.

**One Boiling Pan** for the gum or size, 30 in. dia.  $\times$  26 in. deep, which must be double-cased and made to stand a steam pressure of 60 to 70 lb.

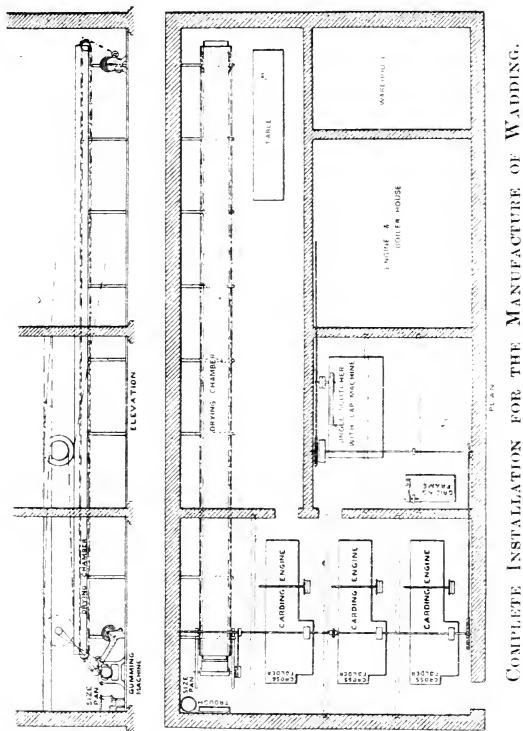

**One Metallic Creeper**, to work overhead and carry the sized wadding through a drying chest.

**One Drying Chest**, usually of wood, 100 ft. long  $\times$  about 20 in. deep inside.

**One Lap-Forming Apparatus**, for lapping the wadding after it is gummed and dried.

### SHORT SYSTEM.

**Thirteen Carding Engines**, fed either by hand or lap, and each provided with a cross-folding apparatus to make folds from 18 in. to 40 in. wide. Also—

- 1 Boiling Pan.
  - 2 Gumming Machine.
  - 1 Metallic Creeper.
  - 1 Drying Chest.
  - 1 Lap-forming Apparatus.
- all as in the "Long" system.

### ABSORBENT COTTON OR SURGICAL LINT.

Absorbent cotton has in recent years been used otherwise than for medical purposes, and is now in requisition industrially for the preparation of compounds of cellulose and artificial silk. The purification of cotton, both for medical purposes and for the special products named, is as important a feature of its course of treatment as is that of rendering it hydrophile in character. As far as cotton for medical purposes is concerned, it has to be remembered that the impurities natural to cotton consist of organic matters, which offer much less resistance to various reagents and are much more susceptible of giving rise to fermentation products, and in consequence more prone to putrefy, than cellulose, which is characterised by negative chemical properties. Therefore the degree of purity of cellulose measures the degree of aseptic power of absorbent cotton and is the essential condition of its hygienic character.

Imperfections in the boiling-out operations may result in only a partial expulsion of the air from the fibres, and this, in spite of all ulterior precautions, causes the introduction of a certain quantity of air into the cellulosic solutions, the presence of which may often account for the resulting cohesion of fibres of artificial silk. Osmotic phenomena are influenced by different factors which call for consideration. Naturally enough, the rate of penetration of salt solutions through the cell wall of the fibre should be slower than that of pure water; the rate of diffusion depends equally on the density and the viscosity of the solutions employed, so that it seems fair to

admit, in extending the law of Graham, that "under the same pressure, liquids pass through the same wall at speeds in inverse ratio to the square root of their density."

The preparation of absorbent cotton should be simple enough when there is only from 5 to 6 per cent. of impurities to remove, but in boiling and bleaching operations as carried out there is risk in introducing others, besides interfering with the strength of the fibre. Boiling-out operations are usually accomplished with alkali in a kier under a pressure of 2 to 3 atmospheres, which gives a temperature corresponding to from 120 to 130 deg. C. Generally a solution of caustic soda (2 to 4 deg. Bé.) is employed, and boiling continued for from 5 to 10 hours. Bleaching is carried out as ordinarily for cotton, though it would undoubtedly be an advantage to use the more soluble hypochlorite of soda, with which the formation of difficultly eliminated insoluble lime salts is not to be feared.

## SPINDLE DRIVING BANDING

In many spinning mills it is customary to make the banding for driving mule and ring frame spindles from the damaged and waste cops produced in the spinning rooms. Two kinds of banding are made for this purpose—tubular, and twisted (or "solid") banding.

**Tubular Banding** is made in the form of plaited braid with a hollow core, by crossing and recrossing several strands of yarn together (the latter having been previously wound from the cops on to bobbins suitable for the machine). The banding produced on this machine is very durable, and will last about three times as long as "solid" banding.



**Twisted or Solid Banding** is made by twisting a number of strands of yarn together after the manner of rope or twine. It is produced cheaply, and not so durable as tubular banding.

## BANDING MACHINES.

**Tubular Banding Machines** are constructed with from 1 to 6 heads, each head containing 12 or 16 spindles. Usually driven by belt power. As the banding is made,

it is wound upon bobbins or spools and put into stock to be used as required.

**Speeds.**—105 revs. per min.

**Pulleys.**—16 in. dia. × 3 in. wide.

**Power.**—3 heads equal  $\frac{1}{16}$  I.H.P.

**Production.**—250 yards per head in 10 hours.

**Floor Space—**

1 head.....1 ft. 8 in. by 1 ft. 8 in.

6 heads.....4 ft. 6 in. by 3 ft.

**High Speed Tubular Banding Machines.**—These machines are entirely self-contained, and are made in three sizes of 8, 16, and 24 spindles respectively. They are formed with two circular racks, one of which is stationary while the other revolves at a high speed. The plating of the threads is effected by pinions, which gear into the racks and alternately carry the threads over and under each other, as the banding is formed. Stop motions are provided for arresting the machines when a thread breaks.

**Speeds.**—8 to 16 spindle machine, 300 to 400 revs. per min.; 24 spindle machine, 250 to 300 revs. per min.

**Pulleys.**—6 in. ×  $1\frac{1}{2}$  in. and 8 in. × 2 in. respectively.

**Power.**— $\frac{1}{3}$  I.H.P. and  $\frac{1}{2}$  I.H.P. respectively.

**Production—**

8 spindle machine.....2 to 3 yards per min.

16 ditto .....3 to 4 yards per min.

24 ditto .....2 to 3 yards per min.

**Solid Banding Machines** are made with 1, 2, 3, or more heads in one frame, up to 18 heads. Each head works independently, and a stop-motion is provided to each spindle.

**Speeds.**—225 revs. per min.

**Pulleys.**— $8\frac{1}{4}$  in. dia. × 2 in. wide.

**Power.**—3 heads equal  $\frac{1}{4}$  I.H.P.

**Production.**—1,200 yards per head in 10 hours.

**Floor Space—**

1 head.....3 ft. by 2 ft. 6 in.

6 heads.....8 ft. by 2 ft. 6 in.; to any length.



# SECTION VI:

## WEAVING

PREPARATORY MACHINES

SIZING METHODS

ETC.

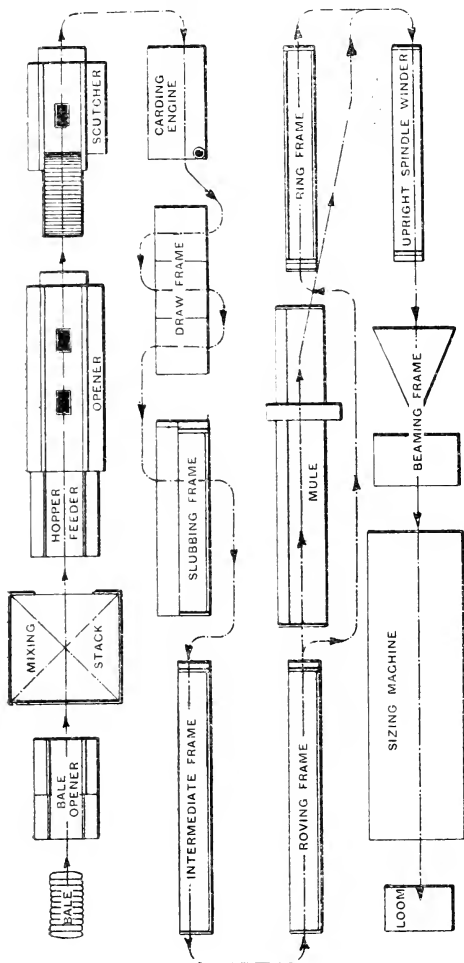

SEQUENCE OF MACHINES FOR SPINNING AND WEAVING ORDINARY COTTON PIECE-GOODS.



## SUMMARY OF MACHINERY FOR A SHED

Containing 350 Looms, weaving Plain Calicoes, and consuming about 10,500 lb. of Yarn in 56½ hours.

---

**Three Winding Frames**, to wind from cops or bobbins on to warpers' bobbins, each frame containing 222 spindles.

**Labour.**—Eighteen winders (six to each frame); or, 37 spindles to each winder. If "patent knotters" are used, ten winders will attend to these frames.

**Four Ordinary Beaming Machines**, each with self-stopping motions, 9/8ths wide, and with Creel for 504 bobbins.

**Labour.**—One operative to each machine.

**One Complete Size-mixing Apparatus**, comprising three becks with pumps and piping.

**One Slasher Sizing Machine**, with creel for six beams, 6 ft. and 4 ft. drying cylinders, 9/8ths wide, to make beams for 40-in. cloth.

**Labour.**—One man and a labourer to look after size mixing.

**One Drawing-in and One Twisting-in Frame.**

**Labour.**—Two men and one boy.

**350 Overpick Looms**, 42-in. reed space.

**Labour.**—One operative to four looms.

**Two Plaiting Machines**, to take in cloth 40 in. wide.

**Labour.**—One youth to each machine.

**One Cloth Press**, worked by hydraulic power, for 40 in. cloth.

**Labour.**—One cut-looker and one assistant, the assistant to work the cloth press. Two Loom Jobbers.

One Working Manager.

**Power.**—100 I.H.P., and a small engine to drive the sizing machine when the looms are not working. Size of small engine—6 in. cylinder, with 12-inch stroke.

One Lancashire boiler, ordinary size.

## PREPARATORY WEAVING PROCESSES AND MACHINERY

Yarn as delivered by the spinning machines is unsuitable both in form and condition for immediate conversion into cloth. Certain preparatory processes—which vary in their nature and extent, according to the style of yarn and the cloth to be woven—are necessary before it can be placed in the loom. Mule cops are usually delivered directly to the manufacturer, who then undertakes all the processes. Spinners of ring yarn and doublers, however, find it more convenient to empty their frame bobbins into one or other of the following forms: hanks, cheeses, ball and chain warps, or back beams; they thus avoid the trouble and expense of dealing with "empties."

In the case of Warp yarn, the preparatory processes have chiefly for their object—(1) The collection of a number of threads sufficient to give the desired width and fineness of cloth. (2) The increase of their strength and smoothness, in order that they may withstand the strain and friction of weaving. (3) The winding of them evenly upon the loom beam in such a manner that each may retain its individuality and occupy a position corresponding with that which it is finally to take up in the cloth. Schemes of warp preparation in ordinary use are as follows (commencing in each case with the material as it leaves the spinning machine):—

### FOR GREY GOODS.

- SCHEME A.**—1. Winding upon warping bobbins.  
2. Warping upon back beams for the slasher.  
3. Sizing, and beaming upon the loom beam, by the slasher sizing machine.
- SCHEME B.**—1. Winding upon warping bobbins.  
2. Ball or chain warping.  
3. Ball sizing.  
4. Beaming or winding upon the loom beam.

### FOR COLOURED GOODS.

- SCHEME A.**—1. Winding to warping bobbins.  
2. Ball or chain warping.  
3. Bleaching or dyeing and sizing of the ball or chain.  
4. Yorkshire dressing and beaming upon the loom beam.
- SCHEME B.**—1. Reeling from cop or ring bobbin into hanks.  
2. Hank bleaching, or dyeing, and sizing.  
3. Winding from hanks to warping bobbins.  
4. Sectional warping and beaming.

- SCHEME C.—1. Reeling from cop or ring bobbin into hanks.  
 2. Hank bleaching, or dyeing, and sizing.  
 3. Winding from hanks to warping bobbins.  
 4. Beam warping.  
 5. Re-beaming to the loom beam.

In every case the last-mentioned process is followed either by drawing in or twisting.

Of the systems for Grey Goods, A is the one mostly used, on account of its greater economy of time and material, B being adopted principally by small manufacturers who have not a sufficient number of looms to keep a slasher sizing machine in full work.

Of the schemes for Coloured Goods, A prevails in certain districts, and appears to be more economical when the number of colours in a warp does not exceed three or four. B is predominant in other districts, and is considered by some manufacturers to produce a better beamed warp, and is more economical when many colours are present. C is chiefly used when a number of loom beams are required to be all of the same pattern.

As regards the preparation of Weft Yarn for "grey" cloths, mule pin cops and ring weft bobbins are ready for the shuttle; but larger cops and hank yarns require to be wound upon pirn bobbins, or into cops of convenient size for the shuttle. Mule weft can now be satisfactorily bleached or dyed in the cop form; but the greater amount of waste made when weaving from such cops greatly discounts the saving effected by the omission of the processes of reeling and pirn winding. It is therefore still the general practice to bleach and dye yarns in the hank form, and afterwards wind to pirn bobbins.

## WARP WINDERS.

### The Vertical Spindle Winder.

**Function.**—To transfer twist or warp yarn from cops or ring bobbins to warping bobbins.

**Description.**—Has down each side two rows of vertical spindles, fitted with wharves and washers and driven by cotton bands from a central tin drum. Bobbins are placed upon the washers, and turn by frictional contact. Cops or ring bobbins are placed upon skewers; and the threads in their passage are held taut and cleared from loose fibres, waste, and thick or soft places, by a flannel-covered board and a brush and snick-plate

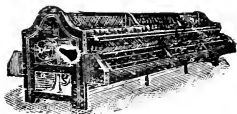

carried by the guider rail. The latter is caused to rise and fall by the traverse motion, and thus to wind the thread layer upon layer on the bobbin. It also moves at a variable speed, slowest near the centre of the lift and quicker towards the ends. This gives a barrel formation to the completed bobbin, with consequent greater contents. Mangle-wheel and heart-cam motions are employed to traverse the guider rail. The back row of spindles down each side have slightly larger wharves than the front row, and therefore revolve more slowly. When about half full, the bobbins are removed from the front spindles to these, in order that the speed of the thread may not become too great as the bobbin nears completion. When high speeds are desired the spindles are made self-contained, after the style of the Rabbeth ring spindle. Empty ring bobbins can be conveyed to the end of the frame, where they fall into a basket, by means of a travelling apron.

**Speeds.**—Tin roller, 650 revs. per min. Driving pulley, 140 revs. per min.

**Pulleys.**—12 in. dia.  $\times$  2½ in.

**Gauge of Spindles.**—Usually 5 in. for bobbins 5-in. lift and 4-in. head.

**Power.**—300 spindles per I.H.P.

**Production.**—600 lb. of 30's yarn in 56½ hours every 37 spindles, or about 16 lb. per spindle.

**Floor Space.**—Width of frame, 5 ft. 6 in.

**Rule to Ascertain Length:**—Multiply half the number of spindles on one side by the gauge, and add 2 ft. 1 in. for gearing and off end.

**Rule to Set a Mangle-wheel Traverse Motion:**—Count half the number of teeth in the mangle-wheel; set the mangle-wheel opposite the pinion that drives it; count half the number of teeth in the rack at side of machine; set the small side of eccentric wheel on mangle-wheel shaft into gear with full side of wheel that gears in rack; set the traverse half-way of bobbin.

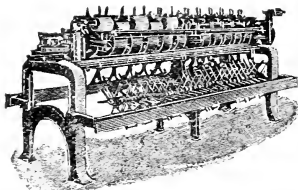

The Drum Winder.

Bleached, dyed, and doubled yarns are usually in the hank state, and when small quantities only of these are used, provision is made in a portion of the spindle machine (described above) for carrying the hanks upon swifts or ryces. Other-

wise the Drum Winder is preferable for winding from hanks, because the thread can be wound at a nearly uniform rate from beginning to end of the bobbin.

A Single Drum Winder consists of a row of drums secured upon a shaft. Each carries two bobbins, which are held in contact with opposite sides of its periphery by spindles and slotted brackets or cradles. The thread is guided from end to end of the bobbin by a guider rail actuated by either heart-cam or mangle-wheel motions. The thread is suitably tensioned by weights hung upon the ryce bosses or upon the lever carrying the lower cage. In this manner tension can be applied without friction, which would result in rubbing off the size from yarns that have been sized in the hank.

A Double Drum Frame has a line of drums down each side, and each carries only one bobbin. Such a machine is more convenient for hanks of large circumference—as linen, jute, and some worsteds—since the ryce holders need not project outwards so far as would be necessary in a single-drum frame. Also the space between the two lines can be occupied by a trough to hold full and empty bobbins, which with a single drum machine must be kept in skips on the floor.

**Speed of Drums.**—150 to 200 per min., for 20's to 30's single.

**Production.**—2 to 3 bobbins per loom.

**Dimensions** of a 40-drum Machine.— $7\frac{3}{4}$  in. pitch, 5 in. traverse, 26 ft. 11 in.  $\times$  4 ft.

**Pulleys.**—10 in.

### Cheese and Cone Winding.

Within recent years considerable progress has been made in the system of winding warp yarn upon straight or conical paper or metal tubes, in such a manner that a pirn cheese or cone, with self-supporting sides, is formed. The process thus dispenses with the flanges required by ordinary warping bobbins, and makes it possible to bleach or dye the material without its requiring to be reeled and rewound. The result is a considerable saving, not only in the cost of the processes last mentioned, but also in the cost of warping bobbins. The momentum acquired by such bobbins during warping is also avoided, and a more uniform tension is preserved upon the threads.

**Split-Drum Winders,**

From Cop, Bobbin, or Hank on to Cheese.

**Description.**—The essentials of the machine are—suitable holding arrangements for cops, bobbins, or hanks; satisfactory guide and tensioning arrangements; a drum to rotate the cheese which it builds up upon itself; a slit in the drum, to act as the guide to the thread; also suitable holding arrangement for the tube or barrel, and ultimately for the cheese built thereon, which, resting on the drum, is turned by surface contact always at the same surface speed. The distribution of the yarn is dependent upon the relationships of the circumference of the drum, the slit that guides the thread, and the diameter of the cheese.

The machine can be made for any length or diameter of cheese, and can be constructed with two-speed driving bowls to suit coarse, fine, or tender yarn, as required.

**Speed.**—Approximately 150 revs. per minute.

**Dimensions.**—Over all, 40 drums (20 each side), 5 in. traverse, to wind from bird-cage bobbins:—16 ft. 5 in.  $\times$  4 ft. 2 in. Ditto, to wind from cops or ring bobbins:—16 ft. 5 in.  $\times$  3 ft. 6 in.

**WEFT WINDERS.**

**Function.**—To transfer weft yarn from hanks or cops to paper tubes, wood pirns, or cops of the correct size for the shuttle. The process is required with weft bleached or dyed in the hank, when the spinning cop is too large for the shuttle, and when wet weft is used for heavily picked goods.

**Types.**—The Cup Winder.

The Disc Winder.

The Cop Winder.

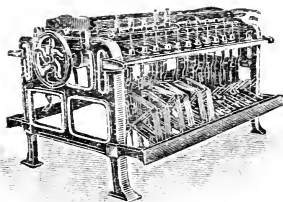
**The Cup Winder.**

A central tin drum drives by means of bands a row of wharves on either side of the frame, which revolve freely upon vertical tubular studs. Immediately above there is a row of metal cups, whose interiors correspond with the conical pirn heads. Long spindles, having heavy heads and flattened ends, are passed

through the pirns, and enter rectangular holes in the tops of the wharves, and therefore revolve with the latter. Motion is transferred to the pirns by wings on the under side of the spindle heads, entering into grooves upon the pirn.

Hanks are carried by ryces or swifts and cops by skewers, and the threads pass over a guider rod, which is caused to rise and fall by heart cams or scroll motions. As winding proceeds the pirn and spindle rise, and the length of the latter is so adjusted that it leaves the wharve when the pirn is filled.

**Speed.**—160 to 200 revolutions of tin drum.

**Pulleys.**—10 in.

**Power.**—160 spindles per H.P.

**Production.**—3 to 4 spindles per loom.

**Floor Space** (for 60 spindles each side).—23 ft. 6 in. × 4 ft. 6 in.

### The Disc Winder.

In this machine the pirns are held in contact by spindles with the bevelled edges of discs, secured upon shafts placed one at either side of the frame. Swivel joints are made

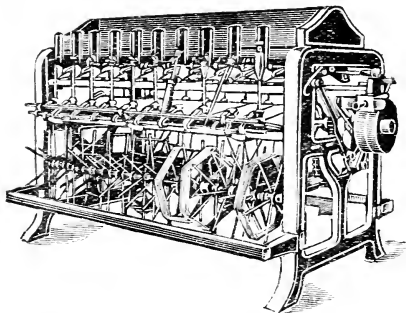

between spindles and heavy heads, which are free to rise in brackets placed above the discs. Bolsters with inclined grooves upon the upper surfaces are suitably fixed to hold a spindle vertical, and a pirn head in rolling contact with a disc. Spindle, head, and pirn rise until the latter is filled, when the spindle point reaches the top of the bolster and slides down the incline to take the pirn out of contact with the disc. The thread is

guided by a hook that projects in front of a disc and is secured to a faller shaft. The discs, and therefore the pirns, are rotated at a variable speed—slower as the thread rises up the cone and quicker as it descends. Thus a uniform winding speed is obtained.

Compared with the cup frame, this machine produces a harder pirn, with longer contents and fewer breakages. It can work weaker yarns, and there is no trouble from bands or tin drum. Theoretically there should be no friction, which glazes the yarn, but this is not borne out in practice, owing doubtless to differences between the bevel of the disc and the cone of the pirn.

**Speed.**—220 to 260 revs. per min.      **Pulleys.**—12 in.

**Power.**—150 spindles per H.P.

**Production.**—2 to 3 spindles per loom.

**Floor Space.**—27 ft. × 4 ft. 6 in. for 60 discs each side.

### The Cop Winder.

The Cop Winder forms a solid cop upon a bare spindle. A disc at the head of a spindle encloses the weft within a cup, similar to that of the cup winder, until a corresponding cone of weft has been formed, whereupon cop and spindle are pushed upwards. Pressure is applied to the spindle-head by a spring, and a quick traverse is imparted to the thread by a rod and an eccentric motion. The lower end of the spindle enters a boss at the top of a tube, which has one-half of a cam clutch at its lower end. The opposite half of the clutch is formed on the under side of a bevel wheel at the bottom of a sleeve, which encloses the tube and is constantly rotated by bevels on a driving shaft. Hank ryces are supported above the machine, and each thread in passing to the cop is taken beneath a grooved washer carried at the end of a lever, which passes beneath the spindle boss and is fulcrumed immediately behind. The lever is balanced by a weight to permit of the thread tension raising its forward end, and connecting the two halves of the clutch to set the spindle in motion. If the thread should break, the lever and boss fall, separating the clutches, and thus stop the spindle and cop from rotating. A similar condition follows upon the completion of the cop by pushing upwards the weighted end of the lever.

This machine enables the maximum quantity of yarn to be placed within a shuttle of given dimensions,



and the thread can be withdrawn from the inside of the cop, which results in better selvages to the cloth.

**Speed.**—160 to 200.

**Pulleys.**—10 in.

**Power.**—120 spindles per H.P.

**Production.**—2 spindles per loom.

**Floor Space.**—24 ft.  $\times$  4 ft. 2 in. for 60 spindles each side.

**Horizontal Spindle Winders.**—Are worked on the quick-traverse principle, and have separate building-motions and stop-motions attached to each spindle. In these machines the fibre is wound on a supporting centre in regular helical coils, which reverse with a sharp bend, each coil crossing over the next preceding coil, binding it in its place at each crossing. The coils being in perfect alignment, they form a self-supporting spool, which will readily unwind. The machine is driven from a gear-box, arranged at one end of the frame.

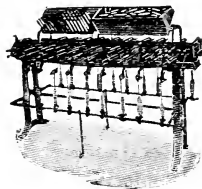

From this gear-box, motion is imparted to two line-shafts, one of which drives the spindles, while the other (having an oscillating motion) operates the traverse-guides. The spindles are driven separately by skew-gear wheels. The traverse movement is operated from small quadrant arms, fixed on the oscillating shaft opposite each thread-guide. These arms are provided with a series of holes, into any of which the connection is made, and the length of the traverse is correspondingly changed.

The builders for the cops consist of screw-threaded rods, upon which rotate small sensitive wheels. At the conclusion of each traverse the wheels are caused to make part of a revolution, and in so doing to move along the rod, each one taking with it the mechanism that carries the thread-guide. When the winding of the cop is completed, the wheel encounters a projection, which puts into action an appliance for stopping the spindle.

When winding upon paper tubes each traverse-motion is fitted with a small shaper-plate, which controls the movement of the traverse-wheel until the cop bottom is formed.

**Speed.**—Spindles, 2,000 revs. per minute.

**Pulley.**—5½ in. dia., 1 in. belt.

**Floor Space.**—7 ft. 0 in.  $\times$  3 ft. 0 in.

## WARPING.

Warping has for its object the placing together of the threads to form a warp, in sufficient number and length, and in such a condition that they can be evenly wound upon the weaver's beam.

**Types.**—The Ball Warper.  
The Beam Warper.  
The Sectional Warper.  
Ball Warp Beaming Machine.  
Yorkshire Dressing.

### The Ball Warper.

Is the oldest form of warper. Its use is now mainly restricted to the making of warps for coloured goods, the slasher sizer having caused its almost entire discontinuance for grey goods.

It consists of two parts—a circular creel to contain bobbins from the spindle or drum winder, and a mill or vertical reel 5 to 18 yards in circumference.

Threads from the bobbins pass singly through the eyes of a leasing heck, and are then made fast to lease pegs at the foot of the mill.

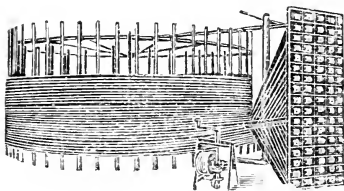

The latter is then rotated, and at the same time the heck rises to coil the threads in spiral form upon the mill. When the required length has been obtained, a second set of pegs is placed and the threads are secured; thereupon the mill is rotated in the contrary direction, when the heck descends and places a second layer of threads upon the first, until the foot pegs are reached. Then another reversal is given to the mill, and so on until the required number of ends are obtained, when the leases are secured by bands, and the warp is withdrawn from the mill and made into a ball or chain. The foot lease is usually formed of half beers or groups of threads for the service of the beamer. At the head an end-and-end lease is formed for the service of the drawer-in or twister.

Are usually made in the following sizes:—

Circumference of Mill.	Floor Space.	Circumference of Mill.	Floor Space.
12 yards .....	19 ft. × 12 ft.	16 yards .....	23 ft. × 18 ft.
14 „ .....	21 ft. × 14 ft.	18 „ .....	26 ft. × 18 ft.
15 „ .....	22 ft. × 15 ft.	20 „ .....	27 ft. × 20 ft.

Length of staves—6 ft., 6 ft. 6 in., 7 ft., 7 ft. 6 in., and 8 ft.

Eyes in heck, from 252 to 420, usually 306. Pitch—fine, 0.206 in.; coarse, 0.237 in.

Bobbins in Creel to suit heck, usually 18 high × 17 wide for 306.

Power motion pulleys—13 in. diam. × 2½ in. wide. Driving pulley to be 7½ in. wide.

**Speed of Mills**—About 170 yards per minute, which gives the following **Speeds of Pulleys**—in power motion:—

Size of Mill .....	12	14	15	16	18	20 yards.
Speed of Pulley ...	59	51	47	44	39	35 revs.

Average production of (say) 30's—About 42,000 hanks per week.

**Attendance**—One man to each mill. **Power**—½ H.P.

### The Beam Warper.

The principal use of the Beam Warper is in the preparation of back beams for the slasher sizer. It is also used for making warps for coloured goods when long lengths of simple striped patterns are wanted; and for winding direct upon weavers' beams when the number of threads is small.

Bobbins from the spindle or drum winder are placed in straight creels or banks or in V-creels. The beam rests upon and is turned by frictional contact with the surface of a wooden drum, which is built up on the driving shaft. A fixed reed at the back, and an expansion reed at the front, separate the threads and contract them to the required width. Machines for coarse and medium counts are usually provided with stop-motions to bring the machine automatically to rest when a thread breaks. Slack yarn given off by the overrunning of the bobbins or unwinding from the beam is taken up by rollers, which are free to rise or fall within grooves formed in the framing. Machines for finer counts that will not stand the weight of the pins

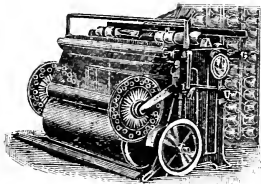

generally used in stop-motions, are provided with an arrangement of falling rods, by means of which considerable lengths can be unwound from the beam for the discovery of broken threads.

Measuring motions are also provided, as well as others to stop the machine when predetermined lengths have been wound.

**Speeds.**—40 revs. per min.

**Pulley.**—15 in. dia. × 2 in. wide.

**Power.**—One machine, .30 I.H.P.

**Production.**—One machine for 80 to 90 looms.

**Floor Spaces.**—

9/8's Machine, 16 ft. by 7 ft. 6 in.

6/4's Machine, 16 ft. by 8 ft.

7/4's Machine, 16 ft. by 8 ft. 6 in.

8/4's Machine, 16 ft. by 9 ft.

**Creel.**—Usually made to contain 504 bobbins.

A 9/8's machine will take in a warper's beam 65 in. from outside to outside of collar. Such a beam is 61½ in. on the wood, and the latter is 4<sup>9</sup>/<sub>16</sub> in. dia. when empty.

An expanding front comb with 504 dents in 54 in. will expand so as to have 358 dents in the same space.

To ensure steady driving of these machines when the power is obtained from a small engine, it is advisable to transmit the power through a countershaft. The latter serves as a governor, and prevents the effect of pulsation.

**Slack-Sided Beams.**—These are caused by uneven tension on the threads as they leave the bobbins in the V creel. The tension is greatest in the middle, and gradually diminishes towards the sides. Beams thus wound are slightly larger in diameter where there is the least tension, and therefore cause trouble in the sizing process. This may be avoided by adopting an arrangement whereby the tension roller in the machine is made in halves, with the centre mounted in a flexible bearing, so as to admit of the two parts of the roller being mounted at suitable angles.

### Overhead Run-ways.

**Function.**—To save labour in conveying warpers' and weavers' beams from one place to another in a cotton mill.

**Description.**—The rails upon which the carriers travel are fixed overhead to any convenient part of the building.

They are constructed with branches to suit the different directions that the carriers are required to travel, and junctions are provided to permit of diverting the course. The carriers or trolleys are each fitted with two pairs of bowls, which run on ball bearings. The lifting blocks connected with the carriers are worked by spur gearing. With these runways very little exertion is required to move the suspended load.



### The Sectional Warper.

Is used for the making of coloured striped warps and also grey ball warps.

V or circular creels contain the bobbins, and the warp is made a section at a time by winding the threads upon circular blocks secured upon a shaft between two flanges. The yarn is pressed sufficiently hard upon the block to make the sides self-supporting after removal from the shaft, and also to counteract the increasing tension upon the threads due to the decreasing size of the bobbins, which would affect to a corresponding degree the diameter of successive sections. Uniform rate of winding is obtained by gradually decreasing the speed of the block as it fills, and motions are provided for measuring the length and registering the revolutions in order that the same number may be given to each section of the same warp.

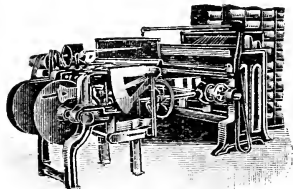

To set the presser motion when a change is made in the number of threads, counts, or width of section—

#### (1) WITH QUADRANT REGULATOR.

Run a few revolutions without yarn, and see that the ratchet wheel is impelled one tooth for every revolution of the section spindle. The empty section block having been placed on the spindle, be careful that the flange which holds the block in its place is adjusted quite close to the edge of the block, and is securely fastened on the spindle by the screw in the flange boss. A few threads of waste "thrums" tied round the section block, and worked into each corner, prevent any warp threads from falling down between flange and ends of section block; a strip of felt or cloth nailed round the edge of each block serves the same purpose.

Fasten the yarn in hole of section block and turn the machine round half a revolution (that is, until the set-screw in boss of flange is at the bottom); then put in the lease; turn the machine another half-revolution, which will bring the screw of the flange to the top, and the lease will then be just over the measuring roller. Now set the cut-measuring motion. Lift up out of gear the double wheel in connection with the worm, and turn the numbered dial round in the direction of the figures until the hand points to the highest number. Loosen the screw which bolts the two sectors together. Allow the presser to fall against the section block, and bring the end of the toothed sector forward until it is opposite the beginning of the index of the fixed sector. This is done by means of the handle attached to the worm shaft.

As the first section will determine the size of change-wheels required on the regulator for all succeeding sections of the warp about to be made, care must be taken that the numbered discs, which record the revolutions of section spindle, are set at zero, and that the index of fixed sector is set as above. The machine will now be ready to start, and the section block can be filled with the length of yarn required for the warp.

When the necessary length of yarn has been run, the number of revolutions made by the section block, as shown by the two discs, must be noted, as also the number on the sector index standing opposite the end of toothed sector—for this last is the number of the teeth required for the change-wheel on the ratchet wheel shaft. The number of revolutions recorded by the section spindle regulates the number of teeth of the change-wheel for the worm shaft, and the number is ascertained by dividing the numbers recorded on discs by 10. For example, suppose 375 and 18 are the respective numbers. These added together make 393, which, divided by 10, gives 39 as the number of teeth required.

To take the section off when filled, relieve the friction bowls from the plate by pushing down the handle which keeps them in contact with the latter; then tighten the screw which fastens the two sectors together, and turn the worm shaft on the regulator a few turns in the direction in which it runs with the handle provided for that purpose. This will remove the presser from the filled section. The flange is then removed and the section taken off and replaced by an empty block, to which the yarn is fastened as already described. Now

loosen the screw which fastens the two sectors together, and allow the index sector to fall back until the presser is against the empty block, or as far as it will go.

Before running the second section, the change-wheels (having been thus ascertained) must be put on and geared by means of the intermediate or carrier-wheel. Care must be taken that the toothed sector has been run back as far as possible by means of the handle of the worm shaft, and that the numbers 25 and 1,000 appear on the respective discs just outside the shields. This is done by drawing the carrier-wheel out of gear, turning the discs to the positions required, and then replacing the carrier-wheel.

See that the presser is in its proper position close against the empty section block; then fasten the two sectors together with the screw for that purpose—and the machine is ready for running-off all the other sections of the warp. No further alteration is required so long as the same class of sections are being made.

The measuring motion is only required for the section in each warp on which the "cut" or "piece marks" are made; but care must be taken that each section has the same number of revolutions run on as recorded on the two discs when running the first section.

To take off all succeeding sections when finished, give the worm shaft a few turns in the direction in which it runs to relieve the presser. Take off the full section, replace with an empty block as before, then turn the worm shaft the reverse way as far as possible. This will bring the presser back to the empty block, and likewise the two discs which record the revolutions to zero; then proceed as before.

The warper must always have the screw of the flange in one position, when she cuts the yarn at the completion of a section.

The number of teeth in change-wheels shown by the machine are not necessary. Any other wheels, whose proportion of teeth are the same, will do. Thus very few change-wheels are necessary.

## (2) WITH LINK REGULATOR.

Remove the link from the studs carried by the presser lever and quadrant, and run the first section. Upon its completion, move the studs along their slots until the link can be slipped upon them and be exactly vertical. This will occur when the stud pointers are at corresponding figures upon the scales carried by quadrant

and presser lever. Before connecting the studs by the link, a mark should be made upon the end of the presser lever, and a pointer be made fast opposite to it in the slot of an arc immediately behind. Any alteration in the positions of quadrant and lever will thus be made apparent.

**Speed.**—100 revolutions.      **Pulleys.**—14 in.  $\times$  2½ in.  
**Power.**—5 H.P.      **Production.**—40 to 50 looms.  
**Floor Space.**—20 ft.  $\times$  7 ft.

#### Running-off Machine.

When the required number of sections have been made, they are placed side by side upon the shaft of this machine, and are tightly screwed between two flanges. Next, the threads are made fast to and wound upon the weaver's beam, or (in the case of ball warps) are withdrawn and coiled into a ball.

**Speed.**—80 revolutions.      **Pulleys.**—14 in.  $\times$  2½ in.  
**Power.**—5 H.P.  
**Production.**—1 machine for 6 or 8 warpers.  
**Floor Space.**—3 ft. 6 in.  $\times$  7 ft. 6 in.

#### Ball Warp Beaming Machine.

**Function.** — The winding of ball warps upon the weaver's beam.

The weaver's beam is placed in the hollow formed between iron drums carried by parallel shafts, which are rotated in the same direction. Iron collars are placed upon the beam ends, and pressure is applied by anti-friction rollers carried by weighted levers, which are fulcrumed upon, and can be slid along a shaft behind. The friction thus set up causes the yarn to be drawn forward, and the pressure results in a hard and level beam. The threads are opened out to the desired width by a coarse reed or wraith, into each dent of which one or more half-beers are placed. Tension is put upon the warp, to cause the threads to separate easily, by weighted mangle rollers. The drums upon each shaft are divided into sections, which can be opened out to any desired width as long as a section upon one shaft covers a gap in the other.

For yarn beams of 45 in. reed space:—

**Speed.**—90.      **Pulleys.**—17½ in.  $\times$  3 in.  
**Power.**—½ H.P.  
**Production.**—One machine 30 to 40 looms.  
**Floor Space.**—40 ft.  $\times$  7 ft. 6 in.



### The Yorkshire Dressing Frame.

Is used when differently coloured threads, dyed separately in the ball state, are to be placed in their required order to form stripes and be wound upon the weaver's beam. The beam is supported between two vertical posts, of which one can be moved to accommodate different widths of beams, and driven by wheel-gearing and stepped cones. The threads from the various balls are first passed between weighted mangle rollers; but as these exert greater holding power upon warps containing more threads than others, provision is made for tensioning each warp separately by a ladder arrangement, in which the staves are removable. Each warp is opened out by grooved rollers to the width required, and the threads are arranged in their proper order, two to four ends in each dent of a reed carried in one hand of the workman. Thus the threads are properly separated, and as broken ones are pieced or replaced, the weaver is relieved from all trouble from these causes.

**Speed.**—80 revolutions.

**Pulleys.**—18 in.

**Power.**— $\frac{1}{2}$  H.P.

**Production.**—One machine, 20 to 30 looms.

**Floor Space** (for 45 in. reed space beam).—8 ft.  $\times$  20 ft.

## SIZING

Sizing is necessary for all single-twist warp yarns. Its primary object is to increase the strength and smoothness of the thread, thus enabling it to withstand the strain and friction incidental to the weaving operation. Other objects of sizing are—the increase of the weight and bulk of the thread; and the improvement of the appearance and feel of the cloth.

A considerable variety of substances are found in size mixings, of which the more important are included in the following:—

(1). Substances possessing adhesive or glutinous properties, to strengthen the yarn and fix other ingredients and all loosely projecting fibres firmly upon its surface. These include flours and starches of wheat, sago, rice, maize, and the potato; dextrine and gum tragazol.

(2). Substances to render the sized yarn soft, pliable, and smooth. These include tallow, grease, oils, wax, glycerine, and soap.

(3). Weighting substances, such as china clay, French chalk, and barytes.

(4). Substances to destroy or prevent the growth of mildew, for which purpose zinc chloride is almost exclusively employed.

(5). Deliquescent substances, to attract moisture to the sized thread, whereby it may retain its pliability and prevent the powdery substances from being rubbed off. Magnesium chloride, calcium chloride, glycerine, and common salt, are used.

Flours are used when strength and weighting substances are required. Starches increase the bulk of the thread. Farina or potato starch is used because of its cheapness, and is suitable for bleached and coloured yarns because it does not dull the colours to the same extent as do flours. Dextrine and Gums are used when very heavy percentages of weight (say 100 to 200 per cent.) are wanted. "Tragasol" is a solution of a pure natural gum in jelly form, of considerable value where strength and smoothness are wanted. It firmly binds weighting substances upon the yarn, and effectually prevents "dusting" or rubbing off of the size during weaving. It also gives a smoothness and finish to the yarn and cloth. Tallows of good quality set hard and firm upon the yarn. Coconut and Palm Oils are fairly good softeners, and are cheap; but they melt at low temperatures, are liable to decomposition, and are dark-coloured: therefore they are generally used along with other softening ingredients. Castor Oil and Glycerine are excellent softeners, but if used alone they darken the colour of the size, and give to the cloth a sticky, greasy feel. Paraffin and Japan Waxes increase the smoothness of the sized thread, set hard upon it, and have high melting points; but they do not mix well. They should be used for grey goods only, as they are difficult to remove in bleaching processes, and cloth containing them comes up blotched after dyeing or printing. Both hard and soft Soaps may be used; they dissolve fatty ingredients, and cause them to mix well, cause china clay to boil thin, and prevent its spurting. But if used along with the chlorides of magnesium, zinc, or calcium, or with Epsom salts, the size is liable to become lumpy, and the antiseptic properties of the zinc chloride are interfered with.

China Clay is the principal weighting substance for grey yarns, being used because of its high specific gravity, easy assimilation with other ingredients, and smoothness. French Chalk is better in colour, but is not

so heavy and is more costly. Sulphate of Baryta is heavier than china clay, but is more gritty and harsh when on the yarn. Sulphate of Magnesia (Epsom salts) and Sulphate of Soda (Glauber's salts) are chiefly used for weighting bleached and coloured yarns and cloth.

With a size containing flour and tallow there is a tendency towards the development of mildew. This is a growth originating from and subsisting on these substances. It is liable to develop at any time either during the manufacture of the size, the weaving of the cloth, or even after a considerable lapse of time from its completion and delivery. In its first stage it may be removed from a fabric by washing, without leaving stain or injury; in the second it may be washed off, but leaves a stain or discoloration; and in the third it attacks the fibre and weakens the fabric to a considerable extent. Substances to prevent its occurrence—termed "Antiseptics"—are therefore necessary. Of these, Zinc Chloride has been found most satisfactory, and a sufficient quantity of this substance included in the size composition will effectually destroy or prevent the formation of such growths. It also adds to the weight of the yarn. Carbolic Acid and Borax have antiseptic properties, but the smell of the first and the colour of the second render them unsuitable for the purpose.

Magnesium Chloride is the principal deliquescent substance used in sizing, because of its powerful attraction for moisture. It also adds to the weight of the yarn. It is sometimes called "Anti," but this should not be understood to mean that it is a preventive of mildew: the contrary is the fact, for the moisture it attracts is distinctly favourable to the development of mildew.

Soda is added in small quantities to neutralise any free acid given off in a mixing and prevent the formation of "iron-mould." Aniline or Indigo Blue is also added to take away the yellow tinge of the size.

## SIZING INGREDIENTS :

### Selection and Testing.

Adhesive substances should be examined with respect to their colour, smell, moisture, adulterations, amount of gluten, and consistency. The colour is compared by placing samples side by side and flattening their surfaces so that they may be in contact with each other. A musty or mouldy smell indicates decomposition. The amount of moisture may be ascertained by weighing a sample and drying in an oven. Mineral adulterations

are left as a residue when a sample is burned over a bunsen flame; others reveal themselves when a paste is formed by boiling, and afterwards allowed to cool in a bowl. It will then set into a firm mould, and on removing from the bowl other ingredients are seen on the surface. The latter test is also used to ascertain the consistency or strength of flour. The firmness of the mould, tenacity of the paste, and length of time elapsing before it runs to water determining the value. Quantity of gluten is ascertained by running water through a muslin bag containing a sample of the flour. After the water has ceased to leave the bag a milky colour, it is removed and the quantity and strength of the gluten left gives a good indication of the value of the flour.

Softeners should be examined with respect to colour, hardness, specific gravity, smell, melting point; China Clay, Chalk, and Barytes for colour and freedom from grit.

Zinc and Magnesium Chlorides can only be satisfactorily tested by expert chemists. Zinc can be bought in the solid and in the liquid conditions. In the latter state it is usually at a strength of 102 degrees Twaddell, or a specific gravity of 1.51, at which strength one gallon will weigh 15.1 lb. and contain about 35 per cent. of solid zinc chloride. Magnesium chloride is usually 56 degrees Tw., or equal to 1.28 specific gravity and 12.8 lb. per gallon, or 24.5 per cent. of solid substance. A gallon of water weighs 10 lb.

### Maize ("Indian Corn") Starch.

Starch made from maize ("Indian corn") is said to be more uniform in its effect on warps than is potato, wheat, or any other kind of starch.

Its condition remains constant for a longer period, and it is more to be depended upon. It penetrates the fibre more thoroughly, and adds strength thereto, without showing a clinging action on being separated from its neighbouring threads.

### TWADDELL HYDROMETER DEGREES.

Zero on the Twaddell Hydrometer equals a specific gravity of 1; in other words, a Twaddell hydrometer immersed in pure water registers 0.

Every 1 deg. Twaddell = .005 of specific gravity; and starting at 0 on the Twaddell hydrometer, which equals specific gravity of 1, we have—

1 deg. Twaddell = Specific gravity of 1.005.

2 deg. Twaddell = Specific gravity of 1.01, etc.

In another form, if  $T$  = Twaddell degrees and  $S$  = Specific gravity,  $T = S \times (1 + T \times .005)$ . Conversely,

$$S = T \times \frac{1}{1 + T \times .005}$$

In a **Rule** this might be expressed as follows:—

To convert Twaddell degrees into actual Specific gravity, multiply by .005 and add 1.

To convert Specific gravity into Twaddell degrees, subtract 1 and divide by .005. (See also pp. 299 and 300.)

### SIZE MIXINGS.

The secret of preparing size lies in the boiling. Every granule of the starch used should be opened, otherwise its full sizing value is not obtained. Size should be cooked, so that its full adhesive properties may be brought out; it will then adhere to the yarn, penetrate it, and, when dry, cement the fibres together so that they may withstand the chafing action of the working parts of the loom with which the warp comes in contact. The value of size lies in the strengthening, lubricating, and softening of the yarn, so as to render it strong, smooth, and pliable.

The composition of a size mixing is determined by the nature of the yarn, its counts, weight of cloth to be woven—*i.e.*, number of ends and picks per inch—whether the cloth is to be used in the grey state or bleached, dyed, or printed, weight to be added, feel desired, and condition of the atmosphere of the weaving shed as regards humidity.

It will be clear that hard and fast rules for proportioning size ingredients are of little use, owing to variation of their qualities, as well as circumstances under which they are used. But generally softeners will form 7 to 14 per cent. of the total weight of the size; for antiseptic purposes 3 per cent. of zinc chloride will suffice. The proportion of zinc is sometimes stated as 8 per cent. of the flour or starch used, and 5 to 10 per cent. of the magnesium chloride, for deliquescent purposes. Both of the latter quantities may, however, be exceeded when it is desired to increase the weight by their means. China clay being the principal weighting agent, its proportions depend upon the weight to be added to the cloth. As to adhesives, wheat flour is invariably used in heavy sizing, because of its larger quantities of gluten, while sago is used for pure size, fine reeds, and

bleaching cloths. The use of farina and other starches is determined by the feel and appearance of cloth desired, as well as the cost of the size.

When farina is used in a mixing, it should never be allowed to boil more than twenty minutes: otherwise its consistency is lost.

Size mixings are classed as light, medium, and heavy, and are further distinguished by the proportions of size and yarn. Thus a 20 per cent. size means that to every 100 lb. of yarn 20 lb. of size are added, which increases its weight to 120 lb. A light size is anything up to 25 per cent., from 25 to 50 per cent. is termed a medium size, and anything above 50 per cent. is termed a heavy size.

In the preparation of size mixings it is well to remember that one which may add 50 per cent. of weight to very soft-twisted yarns may probably add only 40 per cent., or even less, to hard-twisted yarns. When yarns variable in twist have to be sized, the size mixing should always be made thinner in density for the hard than for the soft, otherwise the size will not penetrate into the interior of the thread, but will adhere to the surface.

So far as weaving qualities alone are concerned—and such only are necessary when the cloth is to be afterwards bleached, dyed, or finished—the addition of 5 to 15 per cent. of a size consisting of adhesive and softening substances is sufficient. We have, therefore, such mixings as the following:—

Wheat flour, 92 per cent.		Sago flour, 92 per cent.
Tallow, 8 per cent		Tallow, 8 per cent.

Flour, 93 per cent.		Tallow, 9 per cent.
Tallow, 5 per cent.		Sago, 24 per cent.
Soap, 2 per cent.		Farina, 67 per cent.

A 12 per cent. mixing, suitable for printers' 36/38's twist, would be obtained by—Water 180 gals., flour 30 lb., farina 150 lb., tragasol 56 lb., china clay 100 lb., and tallow 21 lb.

A 15 per cent. mixing, suitable for printers, would be be—Water 250 gals., flour 140 lb., farina 112 lb., tragasol 84 lb., china clay 112 lb., and tallow 28 lb. Boil the flour first, then add the farina and other ingredients.

A 15 to 25 per cent. ball warp mixing, suitable for coarse and medium counts, would be—Water 140 to 210

gals., flour 280 lb., tragasol 70 lb., china clay 224 lb., and tallow 35 lb.

A 25 per cent. mixing would be obtained by—  
 67 per cent. wheat flour.  
 10 per cent. tallow.  
 20 per cent. china clay.  
 3 per cent. zinc chloride.

Another 25 per cent. mixing, suitable for 16/28's twist, would be—Water 120 gals., sago 224 lb., tragasol 56 lb., tallow 10 lb. Boil well.

Another 25 per cent., for medium and coarse counts (hot-air drying slasher)—Water 55 gals., farina 112 lb., tragasol 35 lb., tallow 4 lb., and soap 3 lb.

A fine counts mixing would be—Water 112 gals., sago 112 lb., tragasol 84 lb., tallow 7 lb.

A mixing specially suitable for dyed yarns of delicate shade, mercerised yarns, etc., would be—Water 40 gals., tragasol 100 gals.

A 50 to 80 per cent. mixing would be—Water 50 to 80 gals., flour 280 lb., tragasol 140 lb., china clay 560 lb., tallow 70 lb., zinc chloride  $3\frac{1}{2}$  gals., and magnesium chloride  $11\frac{1}{2}$  gals.

A 50 per cent. mixing may be composed of—  
 53 per cent. wheat flour.  
 30 per cent. china clay.  
 8 per cent. tallow.  
 5 per cent. magnesium chloride.  
 3 per cent. zinc chloride.  
 1 per cent. soda.

Or— 34 per cent. wheat flour.  
 5 per cent. sago.  
 26 per cent. china clay.  
 6 per cent. French chalk.  
 14 per cent. paraffin wax.  
 11 per cent. magnesium chloride.  
 4 per cent. zinc chloride.

For 100 per cent.—

Tragasol, 2 per cent.  
 Wheat flour, 23 per cent.  
 China clay, 31 per cent.  
 Tallow, 15 per cent.  
 Glycerine, 3 per cent.  
 Magnesium chloride, 15 per cent.  
 Zinc chloride, 11 per cent.

The foregoing proportions are used in the following manner:—

Suppose it is desired to size 2,000 lb. of yarn to such an extent that 80 per cent. of its weight of size may remain upon it when woven into cloth. Allowing for a loss of 10 per cent. during weaving and 5 per cent. for size left over, the total to be added will be 95 per cent., making  $2,000 \times 95/100 = 1,900$  lb. of size to prepare. Using the 100 per cent. mixing given above, we should require:—

Tragasol.....	2 per cent. of 1900	=	38 lb.
Flour .....	23	" "	= 437 "
Clay.....	31	" "	= 589 "
Tallow .....	15	" "	= 285 "
Glycerine .....	3	" "	= 57 "
Mag. chloride	15	" "	= 285 "
Zinc	11	" "	= 209 "
			1900

The "tragasol" mentioned in some of the foregoing mixings is obtained in the form of a natural gummy product, from the kernels of the "locust bean." It is the fruit of the carob tree (*ceretonia siliqua*), which grows plentifully in most countries bordering the Mediterranean. It is a tough, aqueous jelly, containing the maximum quantity of the true gum, and in a pure state is practically without colour, taste, or smell. Tragasol seems to enter not merely in admixture, but into combination, with all starches, and also with many other ingredients used in sizing.

#### Size Mixing Apparatus.

With a pure size, containing only adhesive and softening substances, the process and apparatus necessary for mixing are equally simple. Flour, sago, or farina are mixed with water, three or four pounds to the gallon, and boiled along with the tallow, etc., from four to six hours. It is then ready for use. Wheat flour is, however, often steeped from two to six weeks before using. This lessens the tendency to mildew, gives a smoother feel to the yarn, and renders the gluten more active.

For other mixings a special plant is necessary in order that the ingredients may be brought together in such a manner as will ensure thorough admixture. Such a plant may consist of three wood becks or cisterns and a boiling pan. The becks are connected by pipes and



fitted with brass force pumps and agitators. In the first beck the flour is mixed with equal weights of water and allowed to ferment, it being kept from settling meantime by the agitator. The second is used for diluting the fermented flour to the desired strength. The third is the mixing beck. Clay, water, soap, and tallow are boiled in the pan (50 to 60 lb. of clay to the gallon of water), and are then run into No. 3 beck, in which fermented flour has been previously boiled one to two hours. Magnesium chloride is next boiled and brought to 56 degrees Tw. at 120 degrees F., and passed into the mixing beck, after which zinc chloride, boiled and reduced to 102 deg. Tw. at 120 deg. F., is added along with the blue colouring matter. The whole is then thoroughly boiled, after which it is ready for use. The zinc is sometimes

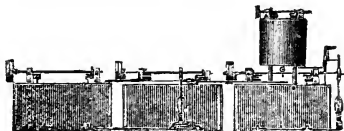

added at an earlier stage should mildew develop. Water is, of course, an essential element in size mixing, the amount varying with the nature and quality of the materials used and the percentage of size to be added to the yarn. It is customary to add sufficient for the preparation and blending of the various ingredients, and afterwards add further quantities to reduce the mixing to the desired strength. This is usually ascertained by the Twaddell Hygrometer, and it is important to remember that when using such instruments readings should be taken at one standard temperature.

**Speed.**—25 revs. per min.

**Pulleys.**—18in. dia.  $\times$  2 in.

**Power.**— $2\frac{1}{2}$  I.H.P.

**Floor Space.**—Cisterns usually 8 ft. long  $\times$  4 ft. wide  $\times$  4 ft. deep with about 1 ft. floor space between each cistern.

## SIZING MACHINERY

**Function.**—The application of size to yarn.

**Types.**—The Ball-warp Sizer; the Dresser Sizer; the Slasher; the Hank Sizer.

### THE BALL-WARP SIZER.

A warp in the form of a loose rope is taken through a long trough containing size, fitted with rollers near the bottom. By passing under and over these rollers, the threads are flattened out, so that every one comes into contact with the size. Squeezing rollers press out any excess of size. The warp is then dried by passing round steam cylinders, and is afterwards wound upon the weaver's beam by the press-beamer.

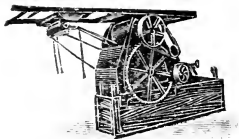

With this method the sized yarn can be thoroughly cooled and "conditioned" before beaming. As there is practically no tension upon the yarn during the process, its elasticity is not impaired. If additional weight or strength be wanted, the warp can be again passed through the size. The process is also convenient for short warps; but in other cases it is expensive, as separate machines and handling are necessary to size, dry, and beam a warp.

### THE DRESSER SIZER.

This machine sizes, dries, and beams a warp in one operation. It is divided into two portions of similar construction, and which treat the yarn in the same manner, and the weaver's beam is placed in the centre of the machine. The threads to form the warp are divided over a number of back beams prepared by the beamer, half



of which are placed at either end of the machine. After passing in pairs through the dents of a reed, the threads are taken between two sizing rollers, the lower of which revolves in a size trough and takes size upon its surface to the contact point where it is pressed into the threads.

Emerging, the threads are divided by a rod, next deflected by a reed to come into contact with the bristles of a revolving brush to lay all loose fibres and again are separated by rods and a reed. Drying is effected by heated air being thrown through the sheet of threads by a fan which is contained within a well, formed by steam chests. At this points the threads from the two ends of the machine are united together, passed through leasing healds and a reed, and finally wound upon the weaver's beam.

This process imparts to yarn the highest possible degree of strength and smoothness; but—because of the high cost, due to the slowness at which the operations proceed, and to the highly skilled labour necessary—it is now only used for the very finest yarns, or in cases where the qualities above mentioned are essential.

### THE SLASHER SIZER.

This is now in general use for the sizing of cotton yarns, it having almost entirely replaced the above-described machines.



A number of back beams, containing in the aggregate sufficient threads to form a warp, and length for many weaver's beams, are placed in a creel at the rear of the machine; and the threads, by passing under and over each other, are combined into a single sheet. In this form they are taken beneath a roller, which is immersed in boiling size contained within a shallow box. One or two pairs of squeezing rollers complete the saturation of the threads, and press out any excess of size. The yarn is then dried by contact with the surface of large steam cylinders, the considerable area of which allows of this process being rapidly performed, and cooled by fans, as far as the speed at which it moves will permit. The threads at this point adhere firmly together, and separation is effected by a series of dividing rods, each of which is passed beneath the threads from a single back-beam. An expansion reed completes the separation of the threads, and also contracts them to the proper width for the weaver's beam. The latter is driven frictionally, so that its speed may be varied to compensate for its constantly increasing diameter, and thus wind the yarn at a uniform speed equal to that at which it is given off

by the draw roller. The latter is driven positively, and is connected by a long shaft with the squeezing rollers. In this manner undue tension upon the yarn is avoided. A slow-motion arrangement enables the machine to be run very slowly instead of being entirely stopped when full beams are to be replaced or dropped ends taken up.

Slashed yarn has not the smoothness nor the elasticity of dressed or even of ball-sized yarn, but these qualities are imparted in degrees sufficient for the weaving of low and medium numbers, and the cost is considerably less. In other cases machines are constructed in which the drying is performed by passing the yarn through chambers containing hot or cold air. The result is a decided improvement in quality of work; but a much smaller quantity is turned off, and for this reason such machines are only used in extreme cases.

To ensure equal distribution of size on to the yarn, it should enter the second chamber at the bottom, so as to come directly upon the steam pipes. It is thus brought to a second boil before contact with the warp threads. A special device is obtainable for this purpose.

**Speeds.**—200 revs. per min.

**Pulleys.**—13 in. dia. × 3 in. wide.

**Power.**—One machine,  $1\frac{1}{2}$  I.H.P.

**Production.**—One machine = 300 looms.

**Floor Space.**—A machine with 6 ft. and 4 ft. drying cylinders and of the following sizes:—

9/8's Machine.....	32 ft. by 8 ft. 6 in.
6/4's Machine.....	32 ft. by 9 ft.
7/4's Machine.....	32 ft. by 9 ft. 6 in.
8/4's Machine.....	32 ft. by 10 ft.

A 9/8's machine will take in a weaver's wood beam 62 in. from outside collar to end of pivot, or an iron beam 60 in. long.

A 9/8's sizing machine, with 7 ft. and 5 ft. tin drying cylinders, working 10 hours a day on dhooties, consumes 3,125 lb. of steam at a pressure of 8 lb. per square inch.

**Air Drying System.**—This system is specially adapted for dealing with delicate yarn, and where quality of output is of greater importance than quantity. Instead of passing the yarn over and under steam-heated cylinders, it is subjected to currents of dry air, produced by fans or air propellers enclosed in a chamber. The air chambers are arranged either vertically or horizontally; but the creel, sow box, and beaming section are the same

as in the cylinder machine. The chief advantage of this system is that the strength, elasticity, and rotundity of the yarn are preserved to a greater extent, and also the "cover," as far as is practically possible. The machines are made the same width as those of the cylinder type, but the length varies according to the system adopted.

In a recently patented machine having a vertical drying chamber is a series of radiating tubes fixed horizontally and vertically in the chamber, through which live steam is passed. These tubes are joined by means of elbows at the ends. At the top of the chamber is a winch or spider roller, over which the warp passes. The yarn, on leaving the warp beam rollers, goes under a roller and is immersed in the size trough, the excess of size being pressed out by a squeezing roller. The yarn then ascends directly to the top of the chamber, over a winch roller, and down again, passing on its way a series of fans. These fans blow the hot air through the threads, causing them to vibrate and to dry quickly. When a second drying is necessary, the yarn again passes through the chamber by way of a small roller, mounted on a level with the winch mentioned. The yarn then encounters the additional heat of a second set of pipes, and is again brought under the influence of the fans. The yarn then passes under a tension roller, through opening rods, onwards to the weavers' beams in the usual manner.

In this system the point of contact between the size box and the first roller is so great that the yarn becomes partially dried, and not liable to deposit thereon some portion of its size, as is the case with horizontal machines.

### HINTS ON SIZING.

Successful sizing requires thorough penetration and saturation of the yarn; thorough and rapid drying, without scorching; proper distribution of the yarn; and the making of a hard, uniform beam.

If the yarn comes from the sizing machine too stiff or too soft, it will not weave well, there will be a diminution of output of cloth, and the quality will be impaired. Weavers assert that "half the weaving is done in the tape-room," inasmuch as good results cannot be obtained from a poorly sized warp.

Softness of warps is sometimes attributable to the water of condensation thinning down the size.

Avoid burning or scorching the warp threads.

Imperfect drying sometimes causes the threads to stick to one another while on the beam.

Surface sizing, in which the size lies on the yarn instead of penetrating it, results in the size being rubbed off in weaving. It is due to the size being too thick, and not sufficiently boiled.

Avoid—Hard and boardy yarn, undersized yarn, soft beams, irregular or rough beams, beams with bad threads, excessive breakages, waste on end piecings, stains and discoloured yarns.

### MARKING OF CUTS.

For measuring and marking the yarn into "cuts" sufficient to weave a given length of cloth, it is taken, after drying, over a measuring roller (14.4 inches in circumference) which is thereby revolved. A wheel upon the end of the roller shaft drives, through a carrier, one upon a short stud that has at the other end a single worm. The latter drives a wheel (called the "bell wheel") of 45 teeth, carried by a shaft having also a cam, so formed as to give at each revolution an abrupt fall to a striker-lever supported upon its surface. When this occurs, the yarn is deflected upon a bowl placed beneath, whose surface is moistened with colouring matter to mark the threads.

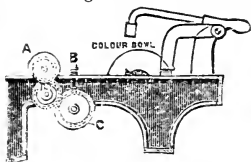

The ratio between the tin roller and stud wheels determines the length between the marks, the bell wheel being unchangeable.

#### Rules for Marking Motions.

Tin roller A, 14.4 inches circumference.

Bell wheel B, 45 teeth.

A set of change wheels includes 17 to 120 teeth.

Cir. of Roller-wheel · Bell-wheel = 648 inches or 18 yards.  
                                 648                                18                                Roller-wheel

$$(1) \frac{\text{Mark in inches}}{648} = \frac{\text{Mark in yards}}{18} = \frac{\text{Stud-wheel C}}{\text{Roller-wheel}}$$

#### EXAMPLES.

FOR 40-yards Mark:—The ratio is here  $\frac{18}{40}$ , and any pair of wheels bearing that ratio will be correct, thus  $\frac{18}{40}, \frac{27}{60}, \frac{36}{80}, \frac{45}{100}, \frac{54}{120}$

FOR 40½-yards Mark:—

$$\frac{18}{40\frac{1}{2}} = \frac{4}{9}, \text{ therefore } \frac{20}{45}, \frac{24}{54}, \frac{28}{63}, \frac{32}{72}, \frac{36}{81}, \frac{40}{90}, \frac{44}{99}, \frac{48}{108}, \frac{52}{117}$$

FOR 40 yards 6 inches, or 1,446 inches:—Here the ratio is 648

Dividing numerator and denominator by 648, we obtain  $\frac{1}{1446}$  2.231

Multiplying the latter by numbers such as will give the nearest 26 39 52

whole number for a denominator, we obtain  $\frac{26}{58}, \frac{39}{87}, \frac{52}{116}$

(It will be understood that in all of the above pairs of wheels the numerator represents the roller-wheel and the denominator the stud-wheel.)

$$(2) \quad \frac{648 \times \text{Stud-wheel}}{\text{Roller-wheel}} = \text{Mark in inches.}$$

$$(3) \quad \frac{648 \times \text{Stud-wheel}}{\text{Mark in inches}} = \text{Roller-wheel.}$$

$$(4) \quad \frac{\text{Mark in inches} \times \text{Roller-wheel}}{648} = \text{Stud-wheel.}$$

FOR Tables giving Tin Roller-Wheels and Stud-Wheels for various Lengths of Cuts, see pp. 234-238.

### HANK SIZING.

Hank Sizing is chiefly adopted for bleached and coloured yarns. Machines are made single and double.

A Single Hank Sizer consists of a beck to contain size, fitted with one or two revolving flanged rollers and two hooks. Knots of hanks are thrown upon the rollers and thereby rotated with their lower ends in the size. When sufficient has been taken up, the hanks are removed and placed upon the hooks. One of these then gives a few turns, twisting up the hanks and wringing out excess size, after which they are untwisted and taken off. Drying is performed by hanging the hanks upon poles in a stove.

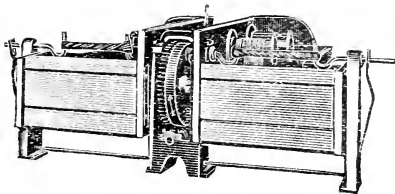

A Double Hank Sizer has two becks, each fitted similarly to the one described above, and both driven from

the same gearing. In the case of double sizing, the hanks are passed through one beck, wrung out, and again passed through the second beck, which contains thicker size than the first. By this process the saturation of the thread with thicker size is more complete.

### HANK DRYING MACHINE.

**Function.**—To dry yarn quickly, which has been sized or dyed in the hank. It takes the place of stoves and other systems in which heat is used. It is well adapted for tender yarns.

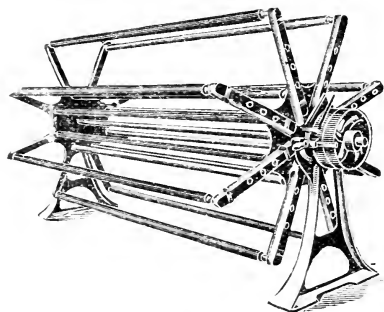

**Description.**— Consists of a swift composed of a series of bars similar to those of a reeling machine, with a corresponding number of rods arranged near the centre. One end of the hank is passed round the bar and the other over the rod. These bars and rods are

loose, and the machine is furnished with two sets, so that one set can be in process of loading while the contents of the other are drying. To ensure the yarn being dried uniformly, the hanks are automatically traversed round the bars and rods.

**Speed.**—110 to 120 revs. per minute.

**Production.**—400 to 450 lb. in 10 hours.

**Floor Space.**—12 ft. 2 in. × 5 ft. 6 in.

### HANK STRETCHING, SHAKING, AND BRUSHING MACHINE.

**Function.**—To restore yarn that has been sized in the hank to its full length, to remove superfluous size, and to make the yarn round and even on the surface.

**Description.**—Brushes the hanks by means of flat reciprocating brushes, operating on either side of the hank. The shaking and stretching are accomplished by a fulling roller, which can be regulated according to the counts and degree of stretching required. An indicator is fitted to the machine, which rings a bell when the hank has completed the one or more revolutions that may be necessary for sufficient brushing and stretching.



By removing the brushes, this same machine can be used for stretching and shaking only.

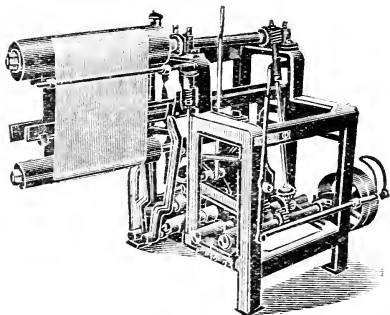

The machines are made to operate on one or two sets of hanks at a time. Yarn treated by this machine winds off and warps with greater freedom.

**Floor Space.**—3 ft. 6 in. × 5 ft. 10 in.

Another type of drying machine is described on page 291, Section VIII.

**Tying-in of Warps.**—When the twisting-in is done by hand, the operator usually has the healds on his left and the new beam to which the ends have to be twisted on his right, stands being provided for carrying the beams. This operation, which is both slow and tedious, may now be done mechanically. A machine for the purpose, if properly manipulated, will tie on an average over 500,000 ends of 21's to 30's yarn per week, the attendance required being one skilled workman and an assistant.

The method adopted in the machine is to so clamp the old and the new warps as to hold them in two parallel sheets, supported in planes one above the other, the old warp or lease being uppermost. The mechanism of the machine then picks the individual threads from each sheet of warp and ties them together, instead of twisting them together, as is done when working by hand. When made, the knots are all of uniform size and the ends are cut off automatically and discharged into a suitable receptacle at the end of the machine. The principle is adaptable to a wide range of counts, varying widths of reeds, and a corresponding variation in the number of dents per inch of reed.

Tables giving Tin Roller-Wheels and Stud-Wheels for Various Lengths of Cuts.

Based upon a 45 bell-wheel and a measuring-roller of 14.4 inches circumference.

NOTE.—See foregoing examples (page 230) for method of ascertaining ratio wheels to mark off above lengths.

Tin Roller Wheel.	Stud Wheel.	Yards.	Inches.	Tin Roller Wheel.	Stud Wheel.	Yards.	Inches.	Tin Roller Wheel.	Stud Wheel.	Yards.	Inches.
99	55	10	0.0	104	67	11	21.5	83	63	13	23.9
95	53	10	1.2	102	66	11	23.3	80	61	13	26.1
91	51	10	3.5	97	63	11	24.9	94	72	13	28.3
96	54	10	4.5	92	60	11	26.6	104	80	13	30.5
92	52	10	6.3	107	70	11	27.9	101	78	13	32.4
97	55	10	7.4	102	67	11	29.6	98	76	13	34.5
93	53	10	9.3	94	62	11	31.4	95	74	14	0.8
91	52	10	10.3	80	53	11	33.3	96	75	14	2.3
94	54	10	12.3	90	60	12	0.0	88	69	14	4.1
97	56	10	14.1	100	67	12	2.2	108	85	14	6.0
100	58	10	15.8	110	74	12	3.9	105	83	14	8.2
91	53	10	17.4	105	71	12	6.2	97	77	14	10.4
94	55	10	19.1	100	68	12	8.6	108	86	14	12.0
97	57	10	20.8	104	71	12	10.4	105	84	14	14.4
95	56	10	22.0	105	72	12	12.3	107	86	14	16.8
98	58	10	23.5	106	73	12	14.3	103	83	14	18.2
96	57	10	24.8	107	74	12	16.1	105	85	14	20.6
99	59	10	26.2	108	75	12	18.0	107	87	14	22.9
102	61	10	27.5	106	74	12	20.4	98	80	14	25.0
95	57	10	28.8	97	68	12	22.3	100	82	14	27.4
93	56	10	30.2	98	69	12	24.2	102	84	14	29.6
96	58	10	31.5	99	70	12	26.2	104	86	14	31.8
94	57	10	32.9	100	71	12	28.1	100	83	14	33.8
92	56	10	34.4	94	67	12	29.9	96	80	15	0.0
90	55	11	0.0	88	63	12	31.9	104	87	15	2.1
106	65	11	1.4	89	64	12	34.0	100	84	15	4.3
91	56	11	2.8	90	65	13	0.0	96	81	15	6.8
89	55	11	4.4	91	66	13	2.0	98	83	15	8.8
100	62	11	5.8	92	67	13	3.9	107	91	15	11.1
90	56	11	7.2	108	79	13	6.0	96	82	15	13.5
96	60	11	9.0	83	61	13	8.2	105	90	15	15.4
102	64	11	10.6	84	62	13	10.3	100	86	15	17.3
92	58	11	12.5	85	63	13	12.3	95	82	15	19.3
98	62	11	14.0	86	64	13	14.2	105	91	15	21.6
104	66	11	15.2	87	65	13	16.1	100	87	15	23.8
91	58	11	17.0	84	63	13	18.0	95	83	15	26.1
97	62	11	18.2	85	64	13	19.9	89	78	15	27.9
106	68	11	19.7	86	65	13	21.8	100	88	15	30.2

Tables giving Tin Roller-Wheels, &amp;c.—Continued.

Tin Roller Wheel.	Stud Wheel.	Yards.	Inches.	Tin Roller Wheel.	Stud Wheel.	Yards.	Inches.	Tin Roller Wheel.	Stud Wheel.	Yards.	Inches.
94	83	15	32.2	99	103	18	26.2	63	76	21	25.7
88	78	15	34.4	93	97	18	27.9	90	109	21	28.8
99	88	16	0.0	86	90	18	30.1	79	96	21	31.4
93	83	16	2.3	80	84	18	32.2	73	89	21	34.0
105	94	16	4.1	93	98	18	34.8	85	104	22	0.8
98	88	16	5.9	87	92	19	1.2	79	97	22	3.6
91	82	16	7.9	82	87	19	3.5	82	101	22	6.1
104	94	16	9.7	93	99	19	5.8	85	105	22	8.5
97	88	16	11.9	88	94	19	8.2	79	98	22	11.8
89	81	16	13.8	84	90	19	10.3	82	102	22	14.0
104	95	16	15.9	93	100	19	12.8	85	106	22	16.1
96	88	16	18.0	89	96	19	15.0	64	80	22	18.0
87	80	16	19.9	85	92	19	17.4	63	79	22	20.6
103	95	16	21.7	81	88	19	20.0	85	107	22	23.7
94	87	16	23.7	89	97	19	22.2	76	96	22	26.5
84	78	16	25.7	86	94	19	24.3	71	90	22	29.4
103	96	16	28.0	83	91	19	26.5	70	89	22	31.9
93	87	16	30.2	80	88	19	28.8	76	97	22	35.1
82	77	16	32.5	87	96	19	31.0	75	96	23	1.4
104	98	16	34.6	84	93	19	33.4	70	90	23	5.1
92	87	17	0.8	81	90	20	0.0	69	89	23	7.8
79	75	17	3.2	87	97	20	2.5	68	88	23	10.6
85	81	17	5.5	84	94	20	5.1	67	87	23	13.4
92	88	17	7.8	82	92	20	7.0	66	86	23	16.4
75	72	17	10.1	79	89	20	10.0	65	85	23	19.4
82	79	17	12.3	77	87	20	12.2	64	84	23	22.5
91	88	17	14.6	82	93	20	14.9	63	83	23	25.7
101	98	17	16.8	80	91	20	17.1	62	82	23	29.0
77	75	17	19.2	78	89	20	19.4	61	81	23	32.5
89	87	17	21.4	76	87	20	21.8	60	80	24	0.0
102	100	17	23.3	81	93	20	24.0	77	103	24	2.8
61	60	17	25.4	79	91	20	26.4	76	102	24	5.7
73	72	17	27.1	77	89	20	29.0	75	101	24	8.6
86	85	17	28.5	75	87	20	31.7	74	100	24	11.7
101	100	17	29.6	79	92	20	34.6	73	99	24	14.8
70	70	18	0.0	77	90	21	1.4	72	98	24	18.0
99	100	18	6.5	75	88	21	4.3	71	97	24	21.3
79	80	18	8.2	79	93	21	6.8	70	96	24	24.7
64	65	18	10.1	83	98	21	9.1	69	95	24	28.2
100	102	18	13.0	76	90	21	11.4	68	94	24	31.8
91	93	18	14.2	64	76	21	13.5	75	104	24	34.6
79	81	18	16.4	68	81	21	15.9	74	103	25	1.9
99	102	18	19.6	77	92	21	18.2	73	102	25	5.4
92	95	18	21.1	86	103	21	20.1	72	101	25	9.0
83	86	18	23.4	79	95	21	23.2	71	100	25	12.7

Tables giving Tin Roller-Wheels, &amp;c.—Continued.

Tin Roller Wheel.	Stud Wheel.	Yards.	Inches.	Tin Roller Wheel.	Stud Wheel.	Yards.	Inches.	Tin Roller Wheel.	Stud Wheel.	Yards.	Inches.
63	89	25	15.4	53	89	30	8.2	55	109	35	24.2
72	102	25	18.0	51	86	30	12.7	50	100	36	0.0
71	101	25	21.8	52	88	30	16.6	54	109	36	12.0
77	110	25	25.7	53	90	30	20.4	40	81	36	16.2
76	109	25	29.4	54	92	30	24.0	53	108	36	24.5
75	108	25	33.1	55	94	30	27.5	45	92	36	28.8
74	107	26	1.0	56	96	30	30.9	40	82	36	32.4
71	103	26	4.1	50	86	30	34.6	53	109	37	0.7
57	83	26	7.6	51	88	31	2.1	48	99	37	4.5
63	92	26	10.3	56	97	31	6.4	43	89	37	9.2
73	107	26	13.8	61	106	31	10.0	52	108	37	13.8
70	103	26	17.5	51	89	31	14.8	48	100	37	18.0
65	96	26	21.0	56	98	31	18.0	44	92	37	22.9
56	83	26	24.4	62	109	31	23.2	51	107	37	27.5
72	107	26	27.0	51	90	31	27.5	48	101	37	31.5
65	97	26	31.0	57	101	31	32.2	45	95	38	0.0
66	99	27	0.0	54	96	32	0.0	42	89	38	5.1
73	110	27	4.4	51	91	32	4.2	48	102	38	9.0
72	109	27	9.0	48	86	32	9.0	46	98	38	12.5
50	76	27	13.0	60	108	32	14.4	44	94	38	16.4
57	87	27	17.1	52	94	32	19.4	42	90	38	20.6
62	95	27	20.9	54	98	32	24.0	47	101	38	24.5
65	100	27	24.9	56	102	32	28.3	45	97	38	28.8
68	105	27	28.6	58	106	32	32.3	43	93	38	33.5
60	93	27	32.4	60	110	33	0.0	47	102	39	2.3
63	98	28	0.0	56	103	33	3.9	45	98	39	7.2
57	89	28	3.8	59	109	33	9.2	49	107	39	11.0
60	94	28	7.2	55	102	33	13.7	42	92	39	15.4
63	99	28	10.3	51	95	33	19.1	46	101	39	18.8
59	93	28	13.4	54	101	33	24.0	44	97	39	24.5
60	95	28	18.0	57	107	33	28.4	47	104	39	29.9
61	97	28	22.4	51	96	33	31.8	41	91	39	34.2
62	99	28	26.7	54	102	34	0.0	44	98	40	3.3
63	101	28	30.9	48	91	34	4.5	47	105	40	7.7
64	103	28	34.9	51	97	34	8.5	46	103	40	11.0
65	105	29	2.8	55	105	34	13.1	49	110	40	14.7
66	107	29	6.5	48	92	34	18.0	48	108	40	18.0
59	96	29	10.4	52	100	34	22.2	43	97	40	21.8
52	85	29	15.2	57	110	34	26.5	38	86	40	26.5
64	105	29	19.1	47	91	34	30.6	48	109	40	31.5
65	107	29	22.7	52	101	34	34.6	47	107	40	35.2
52	86	29	27.7	41	80	35	4.4	46	105	41	3.1
53	88	29	31.9	48	94	35	9.0	45	103	41	7.2
63	105	30	0.0	56	110	35	12.9	44	101	41	11.5
61	102	30	3.5	40	79	35	19.8	43	99	41	15.9

Tables giving Tin Roller-Wheels, &amp;c.—Continued.

Tin Roller Wheel.	Stud Wheel.	Yards.	Inches.	Tin Roller Wheel.	Stud Wheel.	Yards.	Inches.	Tin Roller Wheel.	Stud Wheel.	Yards.	Inches.
42	97	41	20.6	38	102	48	11.4	29	91	56	17.4
41	95	41	25.5	39	105	48	16.6	33	104	56	26.2
40	93	41	30.6	40	108	48	21.6	30	95	57	0.0
45	105	42	0.0	38	103	48	28.4	34	108	57	6.4
44	103	42	4.9	39	106	48	33.2	32	102	57	13.5
43	101	42	10.0	40	109	49	1.8	30	96	57	21.6
45	106	42	14.4	38	104	49	9.5	33	106	57	29.5
44	104	42	19.6	39	107	49	13.8	31	100	58	2.3
46	109	42	23.5	40	110	49	18.0	29	94	58	12.4
45	107	42	28.8	37	102	49	22.4	32	104	58	18.0
44	105	42	34.4	38	105	49	26.5	31	101	58	23.2
38	91	43	3.8	35	97	49	31.9	30	98	58	28.8
45	108	43	7.2	36	100	50	0.0	29	95	58	34.8
44	106	43	13.1	37	103	50	3.9	28	92	59	5.1
41	99	43	16.7	38	106	50	7.6	30	99	59	14.4
38	92	43	20.8	35	98	50	14.4	32	106	59	22.5
42	102	43	25.7	36	101	50	18.0	31	103	59	29.0
39	95	43	30.5	38	107	50	24.6	30	100	60	0.0
45	110	44	0.0	34	96	50	29.6	29	97	60	7.4
44	108	44	6.5	36	102	51	0.0	28	94	60	15.4
41	101	44	12.3	38	108	51	5.7	30	101	60	21.6
36	89	44	18.0	34	97	51	12.7	29	98	60	29.8
44	109	44	21.3	36	103	51	18.0	28	95	61	2.6
37	92	44	27.2	38	109	51	22.7	32	109	61	11.3
40	100	45	0.0	33	95	51	29.5	31	106	61	19.7
43	108	45	7.5	36	104	52	0.0	30	103	61	28.8
42	106	45	15.4	38	110	52	3.8	29	100	62	2.5
43	109	45	22.6	31	90	52	9.3	28	97	62	12.9
35	89	45	27.8	34	99	52	14.8	27	94	62	24.0
40	102	45	32.4	37	108	52	19.5	30	105	63	0.0
43	110	46	1.7	30	88	52	28.8	31	109	63	10.5
39	100	46	5.5	36	106	53	0.0	30	106	63	21.6
42	108	46	10.3	31	92	53	15.1	31	110	63	31.4
38	98	46	15.2	37	110	53	18.4	30	107	64	7.2
41	106	46	19.3	34	102	54	0.0	29	104	64	19.9
42	109	46	25.7	36	109	54	18.0	30	108	64	28.8
38	99	46	32.2	29	88	54	22.3	26	94	65	2.8
39	102	47	2.8	36	110	55	0.0	30	109	65	14.4
40	105	47	9.0	31	95	55	5.8	26	95	65	27.7
38	100	47	13.3	29	89	55	8.7	27	99	66	0.0
39	103	47	19.4	35	108	55	19.5	28	103	66	7.7
40	106	47	25.2	31	96	55	26.7	29	107	66	14.9
38	101	47	30.3	29	90	55	31.0	27	100	66	24.0
39	104	48	0.0	35	109	56	2.1	28	104	66	30.9
40	107	48	5.4	32	100	56	9.0	26	97	67	5.5

Tables giving Tin Roller-Wheels, &amp;c.—Continued.

Tin Roller Wheel.	Stud Wheel.	Yards.	Inches.	Tin Roller Wheel.	Stud Wheel.	Yards.	Inches.	Tin Roller Wheel.	Stud Wheel.	Yards.	Inches.
31	116	67	13	23	105	82	6	18	104	104	0
28	105	67	18	24	110	82	18	18	105	105	0
27	102	68	0	18	83	83	0	18	106	106	0
24	91	68	9	16	74	83	9	18	107	107	0
21	80	68	21	14	65	83	21	18	108	108	0
22	84	68	26	23	107	83	27	18	109	109	0
24	92	69	0	15	70	84	0	18	110	110	0
14	54	69	15	25	117	84	9	18	111	111	0
16	62	69	27	18	85	85	0	18	112	112	0
27	105	70	0	19	90	85	9	18	113	113	0
29	113	70	5	20	95	85	18	15	95	114	0
29	114	70	27	18	86	86	0	18	115	115	0
18	71	71	0	23	110	86	3	18	116	116	0
24	95	71	9	24	115	86	9	16	104	117	0
27	107	71	12	21	101	86	21	16	105	118	4
14	56	72	0	24	116	87	0	16	106	119	9
27	109	72	24	19	92	87	6	15	100	120	0
24	97	72	27	16	78	87	27	16	107	120	13
18	73	73	0	18	88	88	0	16	108	121	18
27	110	73	12	21	103	88	10	16	109	122	22
24	98	73	18	18	89	89	0	16	110	123	27
27	111	74	0	21	104	89	5	16	111	124	31
25	103	74	6	23	114	89	8	16	112	125	0
24	99	74	9	14	70	90	0	16	113	127	4
24	100	75	0	16	80	90	0	16	114	128	9
17	71	75	6	18	91	91	0	16	115	129	13
27	113	75	12	15	76	91	7	16	116	130	18
24	101	75	27	21	107	91	26	14	102	131	5
18	76	76	0	18	92	92	0	15	110	132	0
25	106	76	12	16	82	92	9	15	111	133	7
20	85	76	18	14	72	92	21	15	112	134	14
18	77	77	0	18	93	93	0	14	105	135	0
24	103	77	9	21	109	93	15	14	106	136	10
27	116	77	12	18	94	94	0	14	107	137	21
25	108	77	27	20	105	94	18	15	115	138	0
15	65	78	0	18	95	95	0	15	116	139	7
23	100	78	9	14	74	95	5	14	109	140	5
16	70	78	27	15	80	96	0	14	110	141	15
18	79	79	0	18	97	97	0	14	111	142	26
24	106	79	18	18	98	98	0	14	112	143	1
18	80	80	0	14	77	99	0	14	113	145	10
24	107	80	9	18	100	100	0	14	114	146	21
14	63	81	0	18	101	101	0	14	115	147	31
24	109	81	27	18	102	102	0	14	116	149	5
18	82	82	0	18	103	103	0	14	117	150	15

SECTION VII:

WEAVING

PLAIN AND JACQUARD

LOOMS

PRINCIPAL WEAVES

ETC.

## WEAVING: THE POWER LOOM.

**Function.**—Forms a fabric by interlacing warp and weft threads.

**Construction.** — Contains parts for the performance of three essential movements—shedding, picking, and beating-up; also for controlling the tension and delivery of the warp, for drawing forward or taking up the cloth as it is produced, and for stopping the loom in the event of breakage or failure of the weft.

Shedding is the operation of dividing the warp into two portions for the insertion of the weft. In the case of small patterns it is performed by healds, controlled by tappets or dobby machines; in larger patterns by harness threads controlled by a jacquard machine.

Picking is the operation of passing the shuttle containing weft through the opening formed in the warp by the shedding motion.

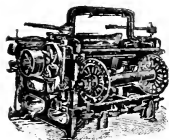

Beating-up—*i.e.*, placing the weft threads in line with one another—is performed by the reed and sley, which, through the action of the cranks and connecting rods, are caused to advance towards and recede from the cloth after each passage of the shuttle and weft.

Other details of the loom must be varied in accordance with the particular kind of cloth to be woven, and the variety is too great to admit of description here.

It may, however, be said that for the simpler kinds of cloths, as plains, twills, sateens, etc., shedding is controlled by under tappets contained within the loom framing, as these allow of high speeds. When frequent change of pattern is required outside tappets are used. Eight to 12 shafts and 16 or 20 picks to the pattern are now considered the limit for tappets. Above these numbers dobby machines are used, as they occupy less room, place no limitation upon the number of picks, and changes of pattern are easily made. Patterns requiring above 20 or 24 shafts of healds are generally woven by the jacquard machine.

Picking Motions are classed as Over Picks and Under Picks. In the former the shuttle receives motion from



a point above the sley, and in the latter case from a point beneath. The Over Pick is generally applied to fast-running looms, as the movement of the shuttle is more gradually developed and a smoother pick results. Strong and heavy fabrics and wide looms have the under picking motion, which can give a stronger blow to the shuttle. It is also cleaner, as oil is not required about its parts near the cloth; it is therefore more suitable for bleached and coloured goods.

High-speed looms weaving light and medium weight cloths have loose reeds, slow looms and heavy cloths have fast reeds.

When different counts or colours of weft are required in the same cloth, shuttle box motions are necessary; of these drop or rising boxes are used for slow looms or heavy goods, and circular or revolving boxes for light goods.

The majority of looms are fitted with taking-up motions of the positive type. These consist of a train of wheels, of which the first is a ratchet wheel, actuated by a pawl from the sley, and transferring motion to a beam or roller whose roughened surface draws the cloth forward.

Letting-off is effected in nearly all light looms by the chain or rope-and-collar friction arrangement, so that the taking-up motion *draws-off* just the amount of warp required. In heavy looms, friction letting-off motions, which act similarly to the chain-and-collar, or the positive letting-off motion in which the tension of the warp regulates the letting-off, are most largely in use. This latter motion necessitates the adjustment of weights, and the nice regulation of the positive drive from the going-part.

By using mechanical let-off motions in place of chains and weights or weighted levers, a cloth of more even texture, and having a better cover, may be produced. These motions are usually governed by the tension on the warp as it passes from the loom beam, and are controlled by the action of the shed upon the oscillating back-rest.

Of the accessory motions of the loom the most important are—the weft-fork mechanism; the shuttle stop-rod motion or the loose-reed motion, for stopping the loom without breakage of the warp should the shuttle stop in the shed; and the warp-stop motion, which stops the loom should any end break down. The value of the last-

named motion has long been questioned, but it is making such rapid headway that it claims notice here.

**Pulleys.**—8 in. to 10 in. dia.

**Floor Space.**—40 in. loom.....6 ft. 10 in. × 4 ft. 1 in.  
Add inches in reed space for other sizes of looms.

**Power.**—One Plain Loom = .16 I.H.P.

**Production.**—Fifty-inch Plain Loom: About 32 lb. twist and weft per loom per 56½ hours.

**Picker Spindle Lubricator.**—Applies the necessary amount of lubricant to the picker spindle of an over-pick loom automatically, and ensures freedom to the picker and minimises wear and tear. The device consists of a small pad saturated with oil, which is carried by an arm secured to the back-board of the loom. At each forward movement of the sley the pad deposits a very small quantity of oil, and on the return movement recedes from the spindle to give clearance for the passage of the picker. (Patented.)

### Speeds of Looms.

The following may be given as approximate speeds, but it will be understood that considerable variations are made therefrom, according to pattern or structure of cloth, counts, and quality of material, size of shuttle, weight of cloth, etc. :—

40 in. reed space, plain loom,	loose reed,	220 to 230 picks per min.
"	"	fast "
"	"	drop-box "
"	"	circular "
"	"	single-lift jacquard
"	"	double-lift "
"	"	single-lift dobby
"	"	double-lift "

Speed counters are now available for registering the number of picks made on a loom. They are usually placed on the floor, at the side of the loom, and are driven from the tappet shaft.

### RULES.

To calculate the speed of a loom—

Multiply the drum on the line shaft by its number of revolutions per minute, and divide by the loom pulley.

To find a loom pulley to produce a given loom speed. Multiply line shaft drum by its revolution and divide by the picks wanted.

It is necessary to allow for slipping of the belt to find the actual loom speed; 8 to 10 per cent. will generally cover this.

To calculate the production of a loom—

$$\frac{\text{Picks per minute} \times 60 \times \text{hour's run}}{\text{Picks per inch} \times 36} = \text{Yards of Cloth.}$$

From this allowance must be made for stoppages of the loom for changing shuttles, piecing warp threads, etc. This will vary from 10 to 40 per cent., according to circumstances of count of weft, size of shuttle, style of fabric, quality of material, but 10 per cent. will cover the loss in the ordinary run of plain goods.

### Taking-up Motions.

The following are trains of wheels or "gears" in common use:—

Rack or Ratchet Wheel.	Beam Wheel.	Stud or Carrier Wheel.	Carrier Pinion.	Circumference of Beam.	Dividend.
50	75	120	15	15 in.	507
60	60	100	12	15 "	507
50	75	100	12	15 "	528
60	75	120	15	15 "	609
60	75	100	12	15 "	634
50	90	146	14	15 "	794

*Rule.*—To find picks per inch from any gear—

$$\frac{\text{Beam Wheel} \times \text{Carrier Wheel} \times \text{Rack Wheel}}{\text{Carrier Pinion} \times \text{Cir. of Beam} \times \text{Change Pinion}} = \text{Picks per inch.}$$

*Rule.*—To find change pinion—

$$\frac{\text{Beam Wheel} \times \text{Carrier Wheel} \times \text{Rack Wheel}}{\text{Carrier Pinion} \times \text{Cir. of Beam} \times \text{Picks per inch}} = \text{Change Pinion.}$$

If picks per  $\frac{1}{4}$  inch are wanted the circumference of the beam must be in quarter inches.

The above formulæ assume one tooth of the rack wheel to be taken up for each pick. If two teeth are moved each pick, divide by 2.

To save the necessity for calculating wheels for each change of picks by the above formula it is usual to find the "Dividend" of the gear. This is a number constituting the product of the picks per inch or per  $\frac{1}{4}$  inch, and the number of teeth in the change wheel

necessary to produce them. Hence if the dividend be divided by a change wheel the result is the number of picks produced, while if it be divided by number of picks the necessary change wheel is obtained.

*Rule.*—To find the dividend of a gear—

$$\frac{\text{Beam Wheel} \times \text{Stud Wheel} \times \text{Rack Wheel}}{\text{Cir. of Beam} \times \text{Carrier Pinion}} = \text{Mathematical Dividend.}$$

It is customary to add  $1\frac{1}{2}$  per cent. to the mathematical dividend to allow for the contraction that takes place after the cloth is removed from the loom. This gives the practical dividend. The dividend, for picks per  $\frac{1}{4}$  inch, of the first-mentioned gear in the above table is—

$$\frac{75 \times 120 \times 50}{60 \times 15} = 500 \text{ Mathematical Dividend.}$$

$7\frac{1}{2} 1\frac{1}{2}$  per cent. added for contraction.

$$507\frac{1}{2}, \text{ say } 507 \text{ Practical Dividend.}$$

With the foregoing mentioned gears, particularly those having the smaller dividends, there is often a difficulty in obtaining an exact number of picks per  $\frac{1}{4}$  inch; also the fact that a smaller pinion gives a greater number of picks, and vice versâ, frequently results in errors. Therefore 7-wheel gears are now used. Of these the "Pickles" gear is an example. It consists of a rack wheel of 24 teeth. Upon the same stud is a "standard" wheel of 36 teeth, gearing into the change wheel. Upon the same stud as the latter is a "swing" pinion of 24 that drives a carrier of 89, with which is compounded a pinion of 15, driving the beam wheel of 90 teeth. The beam is 15.05 inches circumference. With this arrangement the number of picks per inch corresponds exactly with the number of teeth in the change pinion. The standard wheel also can be changed. Thus, when the latter has 27 teeth, every tooth of the change wheel is equal to  $1\frac{1}{3}$  picks per inch; with 18 standard one tooth of the change wheel is equal to 2 picks, and with 9 standard to 4 picks.

**Table of Change Wheels required for giving the Number of Picks per Quarter Inch, with the following Taking-up Motions and Dividends:—**

**DIVIDEND 507.**

Rack wheel .....	50	Beam wheel .....	75
Stud wheel .....	120	Little pinion wheel .....	15
Circumference of Emery		Beam..... 15 inches	

Wheel. Picks per $\frac{1}{4}$ inch.	Wheel. Picks per $\frac{1}{4}$ inch.	Wheel. Picks per $\frac{1}{4}$ inch.	Wheel. Picks per $\frac{1}{4}$ inch.
14—36.214	32—15.844	50—10.14	68—7.456
15—33.8	33—15.364	51— 9.941	69—7.348
16—31.688	34—14.912	52— 9.75	70—7.243
17—29.824	35—14.486	53— 9.566	71—7.141
18—28.167	36—14.083	54— 9.389	72—7.042
19—26.684	37—13.703	55— 9.218	73—6.945
20—25.35	38—13.342	56— 9.054	74—6.851
21—24.143	39—13.	57— 8.895	75—6.76
22—23.045	40—12.675	58— 8.741	76—6.671
23—22.043	41—12.366	59— 8.593	77—6.584
24—21.125	42—12.071	60— 8.45	78—6.5
25—20.28	43—11.791	61— 8.311	79—6.418
26—19.5	44—11.523	62— 8.177	80—6.338
27—18.778	45—11.267	63— 8.048	81—6.259
28—18.107	46—11.022	64— 7.922	82—6.183
29—17.483	47—10.787	65— 7.8	83—6.108
30—16.9	48—10.563	66— 7.682	84—6.036
31—16.355	49—10.347	67— 7.567	85—5.965

**DIVIDEND 609.**

Rack wheel.....	60	Beam wheel .....	75
Stud wheel .....	120	Little pinion wheel .....	15
Circumference of Emery		Beam..... 15 inches	

Wheel. Picks per $\frac{1}{4}$ inch.	Wheel. Picks per $\frac{1}{4}$ inch.	Wheel. Picks per $\frac{1}{4}$ inch.	Wheel. Picks per $\frac{1}{4}$ inch.
16—38.062	34—17.912	52—11.712	70—8.7
17—35.824	35—17.4	53—11.491	71—8.577
18—33.833	36—16.917	54—11.278	72—8.458
19—32.053	37—16.459	55—11.073	73—8.342
20—30.45	38—16.026	56—10.875	74—8.23
21—29.	39—15.615	57—10.684	75—8.12
22—27.682	40—15.225	58—10.5	76—8.013
23—26.478	41—14.854	59—10.322	77—7.909
24—25.375	42—14.5	60—10.15	78—7.808
25—24.36	43—14.163	61— 9.984	79—7.709
26—23.423	44—13.841	62— 9.823	80—7.612
27—22.556	45—13.533	63— 9.667	81—7.519
28—21.75	46—13.239	64— 9.516	82—7.427
29—21.	47—12.957	65— 9.369	83—7.337
30—20.3	48—12.687	66— 9.227	84—7.25
31—19.645	49—12.429	67— 9.09	85—7.165
32—19.031	50—12.18	68— 8.956	86—7.081
33—18.455	51—11.941	69— 8.826	87—7.

**Table of Change Wheels.—Continued.**

**DIVIDEND 528.**

Rack wheel ..... 50      Beam wheel ..... 75  
 Stud wheel ..... 100      Little pinion wheel..... 12  
 Circumference of Emery Beam..... 15 inches

Wheel. Picks per $\frac{1}{4}$ inch.	Wheel. Picks per $\frac{1}{4}$ inch.	Wheel. Picks per $\frac{1}{4}$ inch.	Wheel. Picks per $\frac{1}{4}$ inch.
14—37.714	32—16.5	50—10.56	68—7.765
15—35.2	33—16.	51—10.353	69—7.652
16—33.	34—15.529	52—10.154	70—7.543
17—31.059	35—15.086	53— 9.962	71—7.437
18—29.333	36—14.667	54— 9.778	72—7.333
19—27.789	37—14.27	55— 9.6	73—7.233
20—26.4	38—13.895	56— 9.429	74—7.135
21—25.143	39—13.538	57— 9.263	75—7.04
22—24.	40—13.2	58— 9.103	76—6.947
23—22.957	41—12.878	59— 8.949	77—6.857
24—22.	42—12.571	60— 8.8	78—6.769
25—21.12	43—12.279	61— 8.656	79—6.684
26—20.308	44—12.	62— 8.516	80—6.6
27—19.556	45—11.733	63— 8.381	81—6.519
28—18.857	46—11.478	64— 8.25	82—6.439
29—18.207	47—11.234	65— 8.123	83—6.361
30—17.6	48—11.	66— 8.	84—6.286
31—17.032	49—10.776	67— 7.881	85—6.212

**DIVIDEND 634.**

Rack wheel..... 60      Beam wheel ..... 75  
 Stud wheel ..... 100      Little pinion wheel ..... 12  
 Circumference of Emery Beam..... 15 inches

Wheel. Picks per $\frac{1}{4}$ inch.	Wheel. Picks per $\frac{1}{4}$ inch.	Wheel. Picks per $\frac{1}{4}$ inch.	Wheel. Picks per $\frac{1}{4}$ inch.
16—39.625	34—18.647	52—12.192	70—9.057
17—37.294	35—18.114	53—11.962	71—8.93
18—35.222	36—17.611	54—11.741	72—8.806
19—33.368	37—17.135	55—11.527	73—8.685
20—31.7	38—16.684	56—11.321	74—8.568
21—30.19	39—16.256	57—11.123	75—8.453
22—28.818	40—15.85	58—10.931	76—8.342
23—27.565	41—15.463	59—10.746	77—8.234
24—26.417	42—15.095	60—10.567	78—8.128
25—25.36	43—14.744	61—10.393	79—8.025
26—24.385	44—14.409	62—10.226	80—7.925
27—23.481	45—14.089	63—10.063	81—7.827
28—22.643	46—13.783	64— 9.906	82—7.732
29—21.862	47—13.489	65— 9.754	83—7.639
30—21.133	48—13.208	66— 9.606	84—7.548
31—20.452	49—12.939	67— 9.463	85—7.459
32—19.813	50—12.68	68— 9.324	86—7.372
33—19.212	51—12.431	69— 9.188	87—7.287

**Particulars Required to Find Prices for Weaving in  
Accordance with the Uniform List.**

*(As required by Act of Parliament)*

(1) Width of reed space measured from the fork grate on one side to the back board on the other.

(2) Width of cloth on the counter.

(3) Counts of reed or number of threads per inch, two in a dent or opening, and where there are less or more than two in a dent it should be stated as follows, always giving the number of threads in each dent first—One in a dent, 1/50; three in a dent, 3/58, etc.

(4) Actual picks, or wheel and dividend, or when Pickles' or other similar taking-up motions are used, the number of teeth to a pick, or pick per tooth, should be given in place of dividend; whenever actual pick is given neither wheel nor dividend is necessary; and when using Whittaker's taking-up motion it is best this should be done.

(5) Length of cloth, care being taken to describe the length of stick if different to 36 inches.

(6) When using twist 28's or coarser, or weft below 40's or above 100's, the actual counts should be given, but when using any other counts they may be described as medium.

(7) The piecework price.

**To Find the Weight of Twist, Weft and Size, in a  
Piece of Cloth to Weigh 8 $\frac{1}{4}$  Pounds.**

*Given*—Cloth 39, Reed 60, wheel 35, yards 37 $\frac{1}{2}$ , twist 32, weft 33, dividend 507.

*Rule*—First: Multiply the length of yarn required 40 $\frac{1}{2}$  yards, counts of reed 60, and width in reed 41 inches together for a dividend; multiply the yards in hank (840) by the counts of the twist for a divisor, and the quotient will be the weight of twist.

$$\text{Thus—} \frac{40.5 \times 60 \times 41}{840 \times 32} = 3.70 \text{ lb. weight of twist.}$$

Second: Multiply the length of piece ( $38\frac{1}{2}$ ss. yards) picks in an inch (57.94) and the width the yarns stand in the reed (41 inches) together for a dividend. Multiply 840, the yards in a hank, by the count of weft, 33, for a divisor. The quotient will be the weight of weft required.

$$\text{Thus } \frac{38\frac{1}{2} \times 57.94 \times 41}{840 \times 33} = 3.29 \text{ lb. weight of weft.}$$

Weight of twist in piece...	3.70 lb.
Weight of weft in piece....	3.29,,
<hr style="width: 10%; margin-left: auto;"/>	
Total weight of yarn .....	6.99,,
Weight of size .....	1.26,,
<hr style="width: 10%; margin-left: auto;"/>	
	<u>8.25,,</u> weight of piece.

#### To Find the Net Weight of Twist or Weft.

**TWIST.**—The figures underneath the respective counts in the following table, if multiplied by the length of yarn and number of ends, placing the decimal point seven figures from the right hand, will give the NET weight of twist in lb. and decimals thereof; thus 32's twist, 40 yards, 2,400 ends—

$$2,400 \times 40 \times 372 = 3.5712000, \text{ or } 3 \text{ lb. } 9 \text{ oz.}$$

**WEFT.**—The same figures, if multiplied by the length of cloth, width in inches and number of picks per inch, placing the decimal point seven figures from the right hand will give the NET weight of weft in lb. and decimals thereof; thus, 40's weft, 40 inches in reed, 40 yards cloth, 60 picks per inch—

$$40 \times 40 \times 60 \times 298 = 2,8608000, \text{ or } 2 \text{ lb. } 13\frac{3}{4} \text{ oz.}$$

Twist or Weft	10's	11's	12's	13's	14's	15's	16's
	1190	1082	992	916	850	794	744
Twist or Weft	17's	18's	19's	20's	21's	22's	23's
	700	661	627	595	567	541	518
Twist or Weft	24's	25's	26's	27's	28's	29's	30's
	496	476	458	441	425	411	397
Twist or Weft	31's	32's	33's	34's	35's	36's	37's
	384	372	361	350	340	331	322
Twist or Weft	38's	39's	40's	41's	42's	43's	44's
	313	305	298	290	283	277	271



Twist or Weft	45's 265	46's 259	47's 253	48's 248	49's 243	50's 238	51's 233
Twist or Weft	52's 229	53's 225	54's 220	55's 216	56's 213	57's 209	58's 205
Twist or Weft	60's 198	62's 192	64's 186	66's 180	68's 175	70's 170	72's 165
Twist or Weft	74's 161	76's 157	78's 153	80's 149	82's 145	84's 142	86's 138
Twist or Weft	88's 135	90's 132	92's 129	94's 127	96's 124	98's 121	100's 119

**To Find the Weight of Twist with  $1\frac{1}{2}$  Per Cent.  
Added for Waste.**

The figures underneath the respective counts, if multiplied by the length of yarn, and number of ends, placing the decimal point seven figures from the right hand, will give the weight in lb. of twist, with  $1\frac{1}{2}$  per cent. added for waste.

Twist .....	10's 1208	11's 1098	12's 1007	13's 929	14's 863	15's 806	16's 755
Twist .....	17's 711	18's 671	19's 636	20's 604	21's 575	22's 549	23's 525
Twist .....	24's 503	25's 483	26's 465	27's 448	28's 432	29's 417	30's 403
Twist .....	31's 390	32's 378	33's 366	34's 355	35's 345	36's 336	37's 327
Twist .....	38's 318	39's 310	40's 302	41's 295	42's 288	43's 281	44's 275
Twist .....	45's 269	46's 263	47's 257	48's 252	49's 247	50's 242	51's 237
Twist .....	52's 232	53's 228	54's 224	55's 220	56's 216	57's 212	58's 208
Twist .....	60's 201	62's 195	64's 189	66's 183	68's 178	70's 173	72's 168
Twist .....	74's 163	76's 159	78's 155	80's 151	82's 147	84's 144	86's 141
Twist .....	88's 137	90's 134	92's 131	94's 129	96's 126	98's 123	100's 121

**To Find the Weight of Weft, with 4 Per Cent.  
Added for Waste.**

The figures underneath the respective counts in the following table, if multiplied by the length of cloth, width in inches, and number of ends per inch, placing the decimal point seven figures from the right hand, will give the weight in lb. of weft, with 4 per cent. added for waste.

Weft .....	10's	11's	12's	13's	14's	15's	16's
	1238	1126	1032	952	884	825	774
Weft .....	17's	18's	19's	20's	21's	22's	23's
	728	688	652	619	590	563	538
Weft .....	24's	25's	26's	27's	28's	29's	30's
	516	495	476	459	442	427	413
Weft .....	31's	32's	33's	34's	35's	36's	37's
	399	387	375	364	354	344	335
Weft .....	38's	39's	40's	41's	42's	43's	44's
	326	317	310	302	295	288	281
Weft .....	45's	46's	47's	48's	49's	50's	51's
	275	269	263	258	253	248	243
Weft .....	52's	53's	54's	55's	56's	57's	58's
	238	234	229	225	221	217	213
Weft ... ..	60's	62's	64's	66's	68's	70's	72's
	206	200	193	188	182	177	172
Weft .....	74's	76's	78's	80's	82's	84's	86's
	167	163	159	155	151	147	144
Weft .....	88's	90's	92's	94's	96's	98's	100's
	141	138	135	132	129	126	124

**NORTHROP LOOM.**

**Function.**—Same as the ordinary power-loom.

**Description.**— This loom possesses, in addition to the shedding, picking, and beating-up mechanisms of the power-loom, a battery, warp stop-motion, feeler and thread cutting motion, and warp let-off motion.

THE BATTERY holds 25 weft bobbins or cops, and places same in the shuttle when weft breaks or runs out.

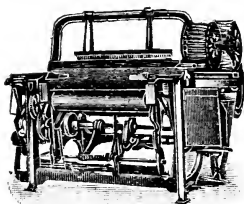

Fabrics woven on Northrop looms are of two classes, which are distinguished as "feeler" and "non-feeler" cloth. The former includes all material in which every pick must be present, and in which a double or half-pick would constitute a serious defect—such as sateens, flannelettes, unions, and dobby and certain jacquard weaves. "Non-feeler" cloth denotes ordinary calico, and such material as is not affected by double or half-picks.

**FEELER AND THREAD CUTTING MOTION.**—The first controls the weft in the shuttles and compels a fresh supply to be inserted before running out; the second is to cut and take care of the loose end of weft from the selvage to battery end: these two combined ensuring perfect cloth.

**THE WARP STOP MOTION** controls the warp threads and stops the loom immediately a thread breaks.

**THE WARP LET-OFF MOTION** controls the letting-off of the warp from the beam automatically.

**Speeds.**—40 in. reed space loom, 175 to 200 picks per min.

**Pulleys.**—12 in. diameter.

**Floor Space.**—40 in. reed space loom, using 8 in. bobbin and 18 in. diameter beam flanges = 7 ft. 2 in. × 4 ft. 2 in.

**Power.**—Averaged on a shed of 500 looms, the same power as the ordinary loom.

**Production.**—Same as the ordinary loom, but the weaver attends to from 12 to 24 looms, according to cloth being produced.

### Northrop Loom Wages.

The following is the text of the Agreement made on June 30th, 1907, between Messrs. Ashton Bros., of Hyde, and the officials of the Weavers' Amalgamation, regarding the payment of wages to the weavers engaged at the firm's mills in minding Northrop automatic looms:—

1. That the wage shall be based on .77 for 20,000 picks, 36 in. cloth.

2. That no objection shall be taken to speeding up the looms above the present speeds.

3. That the number of looms to be worked by any employé is not to be limited, provided employer and employé agree upon the number to be worked by such employé.

4. That the above covers up to and including 56 reeds; reeds above 56 to have .00834 for 20,000 picks added for

every two counts up to and including 60's; above 60's .01416 for every two counts up.

5. The prices for 32 in. and 40 in. cloth to be worked out to give a like wage; 32 in. loom running 176 picks, 40 in. 160 picks.

6. 64 in. cloth to be paid 1.5d. for 20,000 picks.

### THE JACQUARD MACHINE.

**Function.**—To control the movement of the healds in shedding, for the weaving of fancy pattern goods.

**Description.**—The mechanism of the jacquard machine is exceedingly simple in its single parts, but complex in the arrangement of these parts. Thus the arrangement for controlling each thread consists of a needle acted on by a hole in the card cylinder, an upright with its neck-band, harness-cord, mail, and lingo, and the knife or knives that lift or leave down the upright. The arrangement of some hundreds of these parts within a very limited space introduces complexities that need to be very carefully considered.

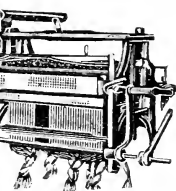

The main features in any jacquard are—the sweep, the connecting or sweep-rods, the lifting levers, the engine proper (consisting of the grid carrying the knives, the knives, the uprights resting on the upper comber-board, the needles controlled by the spring-box and needle-board, and the card-cylinder, which should present each card satisfactorily to the needle), and the harness. The harness consists of neck-bands, harness-cords, mails and lingos (weights), and the lower comber-board. A jacquard of any capacity may be placed on any loom (plain or box); but as a rule the jacquard will limit the speed.

#### Single-lift.

Used principally for weaving ordinary cottons, etc., and where a high speed is not required. Made with hooks, so that harness can be changed by unhooking the neck cords. Driven from the crank shaft, and will weave 120 to 130 picks per minute. The harness worked by this jacquard may be tied up (straight or fancy tie) to any set.

#### Double-lift Single-cylinder.

For all-round work, and is usually fitted with an ordinary Card Turning-back motion. Made with 200's, 300's, 400's, 600's, 800's, and 1,200's needles.

**Double-lift Double-cylinder (Slide Motion).**

Double-lift, with cylinders working alternately. May be worked up to 220 picks per minute. Lifting levers and cylinder motion worked from bar shaft. Made with 400's, 600's, 800's, and 1,200's needles.

**JACQUARD CARD LACING MACHINE.**

**Function.**—Joins together the cards for controlling the shedding in weaving fancy cloth.

**Description.**—Are made with three, four, five, or six heads, each provided with its own needle and shuttle. Each head is adjustable independently, either to the right or left hand; and the machines are generally made in two sizes—one for cards from 4 to 26 inches, and one for cards up to 42 inches long. The length of stitch can also be adjusted, up to 2½ inches.

The cards are placed by the operator upon feeding-wheels, having carrying-pins, which retain and accurately space the cards while the forward motion of the wheels feeds them between the needles. The stitch made in this operation should be on the lock-stitch principle, so that each tie is independently secured.

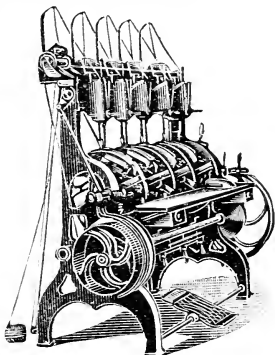

**Production.**—From 15 to 18 cards per minute when operated by foot power, and 28 cards per minute when mechanically driven at 80 revolutions per minute.

**CARD-CUTTING MACHINES.**

**Function.**—To punch the holes in jacquard cards, according to specified designs, and in the order they are to operate the needles.

**Plate Machine.**—The operation on this machine is slow, the plate being usually reset for every distinct pick in the design; but if there are many similar picks in the design it is obviously the quicker, as one setting of the plate will enable all similar picks to be cut in a few moments. A good cutter can cut from 50 to 60 cards per hour (300's cards).

**Piano Machine.**—This machine feeds the card into the line of 8, 10, or 12 cutting punches controlled by the

fingers, so that the fingers indicate the correct punches; one foot cuts and the other foot (or treadle) controls the movement forward of the card. A good cutter will cut from 100 up to 120 cards per hour (300's cards).

There are many styles of **Repeaters**, but as a rule their complexity and expense exclude them from ordinary use. The hand-feed Single-card Repeater, however, is not too expensive, and if properly attended to does its work well.

### WARP MOISTENING APPARATUS.

**Function.**—To dispense with steaming in moistening the warp threads when weaving piece-goods.



**Description.**—Consists of a brass tube, slightly longer than the width of the warp, fixed to the framing at the rear of the loom. The tube has a portion of its shell cut away to provide an opening for the discharge of a fine spray or mist, which it deposits on the threads. In this trough are two brushes, one of which is stationary, and the other rotates at a slow speed. The trough is filled with water until it partially submerges the brush. As the latter revolves, it impinges against the bristles of the stationary brush, and by so doing flirts off the water in the condition required. The moisture is applied to the warp threads as they leave the beam and before they pass over the back-rest, which is the point at which the threads are subjected to a great degree of strain or tension. The brush is rotated from the loom crank-shaft by a cam, operating a ratchet-and-pawl arrangement, the speed of which is controlled by that of the loom.

### PLAITING OR FOLDING MACHINE.

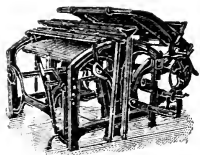

**Function.**—The plaiting of cloth into folds of given length, thus measuring it, and facilitating the examination by the cloth-looker.

**Description.**—The machine is provided with a folding table, constructed in circular form and arranged to rise and fall vertically. Across the front and back, extending from one side to the other, is a grip rail or retaining bar, the under surface of which is clothed

with strong card wire. As the cloth enters the machine, it is laid in plaits of uniform size, by the oscillating movement of a folding blade, the stroke of which can be adjusted to give various lengths of folds. The machine is usually provided with an index plate for recording the number of folds in the length of cloth folded.

**Speeds—**

40 in. cloth.....	72 folds per min.
50 in. cloth.....	70 folds per min.
60 in. cloth.....	65 folds per min.
70 in. cloth.....	60 folds per min.

**Pulleys.**—10 in. dia.

**Power.**— $\frac{1}{2}$  I.H.P.

**Production.**—One machine to 200 looms.

### CLOTH PRESS.

**Function.**—After the cloth has been inspected by the “cut-looker,” it is placed in this machine in batches of several folded pieces. It is then pressed tightly, and, while still under pressure, is secured with twine.

**Description.**—The machine is fitted with a top and a bottom table, one of which is stationary, and the other capable of moving vertically between strong upright guide rods. The movable table is usually actuated by a hydraulic ram, and the necessary pressure for the cloth or bundle is effected by the closing of the space between the two tables.



**Speed.**—80 revs. per min.

**Pulley.**—20 in.

**Power.**—1 I.H.P.

**Production.**—One machine for an average-sized shed.

**Floor Space.**—6 ft. × 2 ft. 6 in.

Cloth Presses are also made with the movable table actuated by heart-cams, duplicated, and worked by powerful wheel gearing.



**Speed.**—60 revs. per min.

**Pulley.**—24 in.

**Power.**— $\frac{3}{4}$  I.H.P.

**Production.**—As above.

**Floor Space.**—As above.

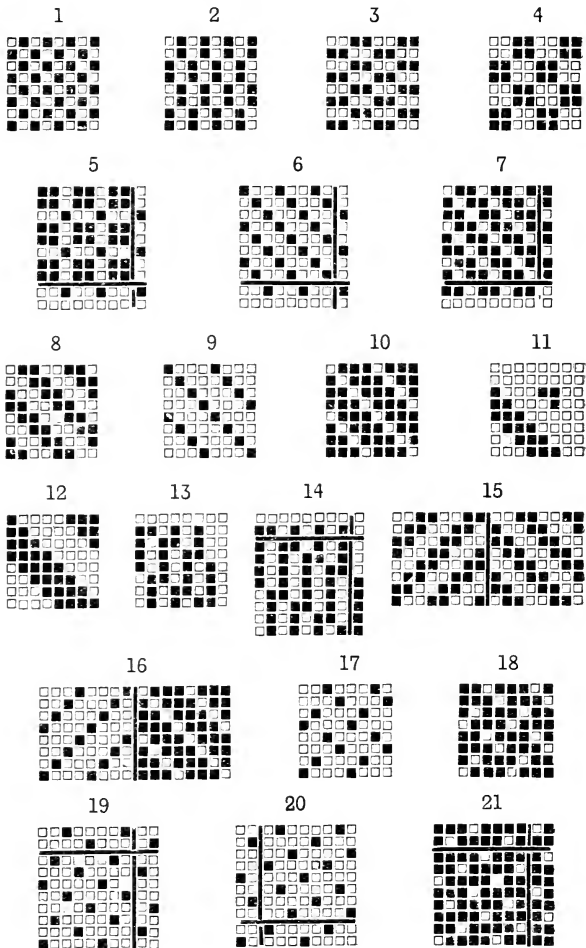



**STANDARD WEAVES FOR COTTON GOODS.**

Standard Weaves employed for cotton goods are given herewith, and may be briefly described as follows:—

**Plain, Calico, or Tabby Weave:—**

When woven with warp and weft approximately equal in number of threads and counts of yarn, the fabric has a plain even surface, and in this manner is produced a large variety of cloths, which differ only in respect of number of threads and yarn counts. Fancy effects are obtained by varying the tension of the warp threads as in "crimp stripes" and "imitation repps." In the former case, tight and slack threads are arranged in stripe form; in the latter case, tight and slack threads are placed alternately. Cord stripe and checks have coarse threads in the warp, or in both warp and weft.

When the warp and weft threads differ considerably in number and thickness, "Cord" effects are produced—as in poplins and repps. Poplins have a large number of ends of fine counts, and a small number of picks of coarse weft, interwoven exactly as in Pattern 1. Frequently, however, Pattern 2 is used, with a finer weft, to produce a poplin, there being two picks in a shed. The true repp is a plain weave, with warp and weft arranged 1 thread fine and 1 thread coarse, the coarse warp thread always being lifted over the coarse weft thread, thereby producing prominent transverse ribs or cords. Imitation repps are also produced by interweaving the threads of a warp arranged 2 coarse, 1 fine, with a medium count weft, and using Weave No. 5. The fine warp is separately beamed and tightly weighted.

When weaving Plain Grey Cloths, it is usual to have the back warp roller of the loom fixed at a higher level than the breast beam, which causes the top line of warp threads to be slack when the shed is formed. Such threads then spread themselves midway between those of the bottom or tight threads, and thereby neutralise the tendency of the pair of threads in each dent to run closely together and form what is known as "reedy" cloth. Cloth with the threads evenly spaced is said to be well "covered."

Designs 2 and 3 produce Transverse and Vertical Cords respectively, the former requiring a greater number of ends than picks, and the latter the reverse conditions.

Design 4 is the 2-and-2 mat, dice, or Hopsack Weave; common qualities of Mattings are also woven with Design

No. 3, using weft twice as thick as the warp and half as many picks as ends per inch.

Twills in large variety are employed for cotton goods, and only the more important small weaves are given. Owing to the direction of twist in ordinary cotton yarns, the twill lines are bolder when they run from right to left, as in the designs given. When twills from left to right are required, it is usual to have the weft spun twist way.

Designs 5 and 6 are the 3-shaft: Jean, Nankeen, Regatta, or Galatea Twill, with weft and warp faces respectively.

Design 8 is the 4-shaft, 2-and-2, Sheeting, Harvard, or Cashmere Twill. Designs 9 and 10, the Florentine Twill upon the same number of shafts. Design 11 is the 6-shaft, and Design 12 the 8-shaft Serge Twill. Designs 13 and 14 are 7-shaft and 9-shaft Corkscrew Twills. Designs 15 and 16 are Herring-bone Twills.

#### Satin or Sateen Weaves:—

Designs 17 and 18 are the 4-shaft satin or satinette, chiefly used in coloured shirtings. Design 19 is the 5-shaft weft face satin or sateen, with the twill running to left, and requiring the weft to be spun ordinary or weft way when the twill is required to be prominent; but if the latter is to be broken or subdued, twist way weft would be used. Design 20 is the same weave with the twill running towards the right, and requiring twist way weft for a bold twill, or weft way weft for a subdued or broken twill. Design 21 is the 5-shaft warp satin or drill. Designs 22 and 23 are 6-shaft satins with weft faces; Design 24 is the 8-shaft satin or Venetian.

#### Honeycomb Weaves:—

Design 25 is the 6-by-6 honeycomb, weavable on 4 shafts of healds; 26 the 8-by-8, weavable on 5 shafts; 27 the 12-by-12, weavable on 7 shafts—all with point or centred drafts. In each case the cloth should have about equal numbers of ends and picks per inch to give good effects. For common qualities wherein the number of picks per inch is considerably less than the number of ends, Designs 28 (6-by-4) and 29 (8-by-6) are used.

Designs 30, 31, and 32 are Brighton honeycomb weaves on 8, 12, and 16 ends and picks respectively. No. 33 is a 10-end Sponge weave.

Huckaback weaves on 10-by-10 and 10-by-6 are given by Designs 34 and 35.

22

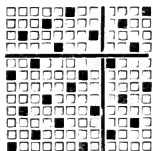

23

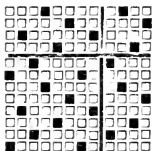

24



25

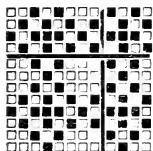

26

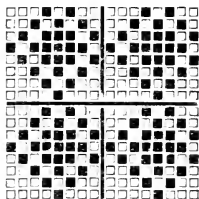

27

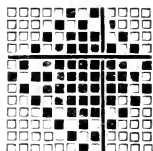

28

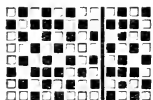

29

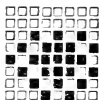

30

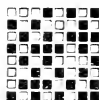

31

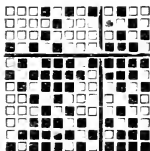

32

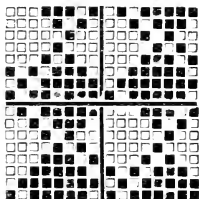

33

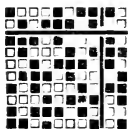

34

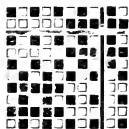

35

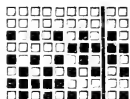

36



**Mock Leno Weaves:—**

Design 36 is the 6-end or 3-and-3 Mock Leno.

..	37	..	8-end or 4-and-4	..	..
..	38	..	10-end or 5-and-5	..	..
..	39	..	5-and-1	..	..
..	40	..	7-and-1	..	..

The denting of mock leno weaves is important when used as ground weaves for figured patterns. Design 36 should have three ends in every dent; 37, four ends; and 38, five ends in every dent; but for stripes wherein the open effect is required to be prominent, the denting

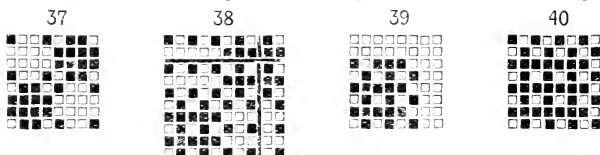

of 36 should be three ends 1 dent, 1 dent empty; for 37, four ends 1 dent, 1 dent empty; and for 38, five ends 1 dent, 1 dent empty. Design 39 should be dented five ends 1 dent, 1 dent empty; one end 1 dent, 1 dent empty. Design 40 should be seven ends 1 dent, 1 dent empty; one end 1 dent, 1 dent empty.

**Gauze and Leno Fabrics.**

These goods are woven by a method entirely different from that of plain and twill cloth weaving—inasmuch as the threads do not interlace in parallel lines, but are drawn out of their straight course, according to the design required. When woven, the fabric is open and firm, because the warp and weft threads when locked together make strong boundaries for the open parts.

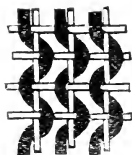
**Lappets**

Are cloths figured by stitching extra warp threads into a ground cloth formed by the plain weave. Between each stitch the figuring or whip threads are moved sideways by needle or lappet frames, in such a manner as to form embroidery-like effects.

**Pile Fabrics.**

When the pile is intended to be produced by the warp, two sorts of warp are necessary—one for the ground or body of the fabric, and one for the pile. This

arrangement admits of the production of two distinct kinds of fabric—namely, plush and terry pile goods. In the former the loops of the pile are cut; in the latter they are left uncut. Sometimes only a portion of the pile is cut, the uncut part being left to produce a figured effect.

### Velvets and Velveteens.

These are generally woven with warp of two-fold yarns, and a large number of weft threads. The latter are of two distinct kinds, one of which forms the ground pick and the other the pile pick. The ground pick may be inserted every 2nd, 3rd, 4th, or 5th pick as required; the pile pick passed over from three to nine warp threads, then under one, so as to form a "float" of weft on the surface. Either a plain or twill back can be produced in the fabric, according to the interlacing of the ground pick.

Twill backed velvets are known as "Genoa" velvets.

Plain do. do. do. do. "Tabby" do.

### Fustian and Velvet Cutting.

**Preparation.**—When the cloth has been woven, it next undergoes a process of stiffening by the application of size to the back of the fabric. This gives "body" thereto, binds the warp and weft threads together, and at the same time prevents the latter from being plucked out by the operating knife. The surface of the cloth is next coated with a solution of "milk of lime," and left to dry. This operation answers a purpose similar to that of stiffening, and enables the knife to retain a keen edge and make a clean cut instead of producing a jagged surface. The floats of weft are not cut in the middle (as in silk velvet), but are severed slightly to the left, in the direction of the cutter. The term "to't" [to it] is applied to this procedure. The process imparts a better appearance to the finished material, and accounts for the fact that a fustian properly cut rubs smoothly in one direction only. If the piece is cut on the "fro't" [from it] side (*i.e.*, to the right, or from the cutter), the pile lies very flat, and spoils the effect that ought to be produced with a high pile.

**Cutting Frame.**—The frame used for cutting the pile is about 2 yards long by 1 yard wide. The end of the piece is drawn over the frame and passed round a roller, which holds it in position by the aid of a ratchet arrangement fixed at the side of the frame. At the opposite end of the frame a strainer is fixed, which

enables the operator to draw the fabric to such tension as shall allow the knife to be pushed along the warp, after the point has been inserted under the float.

To prevent the wood of the frame from wearing, a bevelled straight-edge is fixed at the far end, over which the cloth passes. Each run of the knife finishes at this straight-edge, so that a complete series of cuts leaves a definite line across the cloth for guidance in commencing the next lot of cuts. Any neglect in this respect causes a zigzag appearance in the fabric, which becomes very noticeable after dyeing and finishing.

**Common Velvets.**—These are known in the trade as "slips," and are generally cut in pairs on the "long-run" principle, in which the frame used is about 13 yards long. This method cannot be practised with velveteens and the better-class velvets, because they contain more floats, and the necessary tension could not be obtained without damaging the fabric. In "slips" every alternate float only is cut—whereas in better-class goods every float is operated upon except for purposes of design. In cutting "slips" the operator has a piece of the cloth on either side of him; he cuts one while walking in one direction, and the other on the return journey, the pieces being arranged accordingly.

**Corduroys.**—Fabrics of this class are woven in the same way as velvets, except that the pile picks are bound by the warp so as to form straight lines of floats; thus producing a ribbed surface. After weaving, the material undergoes (before cutting) the same stiffening and liming process as velvets.

Corduroys are made in many varieties—known as fine reed, eight shafts, thicksets, constitutions, cables, etc. Constitutions and cables have broad floats or races, which are some distance apart, and are usually cut by machinery. The machines used are provided with a number of circular discs corresponding to that of the races to be cut. These discs are mounted on a revolving shaft, and as the cloth passes underneath, the discs sever the float threads.

This machine is only suitable for the two varieties mentioned, inasmuch as the pile flattens after slight wear, and the rib appearance is lost—whereas when cut by hand the ribs remain distinct, even after rough usage. When cut by hand, the material is placed on a slight incline towards the point where the operator finishes his stroke.

**SOME FABRICS AND LOOMS FOR WEAVING SAME****Alhambra** and other Quilts—

Woven on special jacquard looms.

**Bedford Cords**, Dimities, Honeycomb, Huckabacks, Herring-bones—

These are rather heavy figured goods. (Bedford cords are woven with backing-up threads to form a cord.)

Woven on a loom of medium weight; fast reed; must have either side tappet, Jamieson's tappet, or dobbie.

**Brocades**, Brilliantes—

Light figured or spotted goods.

Woven same as above, but on a light loom; loose reed.

**Cambrics** (See under Domestics)—

Fabrics made from fine yarns, 24 to 36 inch reeds and picks. Woven on plain loom with leno motion.

**Checks**—

Fabrics with square pattern, formed by coloured stripes in both warp and weft. Woven on box looms.

**Cords** (See under Fustians)—

Plain cloths, with ends crammed together to form a cord.

**Crimps**—

Cloths woven from two or more warps, one slacker than the other, thus giving a "crimped" or "cockled" effect.

Woven on a loom of medium weight, with two yarn beams; dobbie or other device for fancy weaving.

**Dhooties**—

Ordinary plain cloths, but with cramped grey or coloured borders; often figured.

Woven on an ordinary plain loom, but with a dobbie for the border.

**Domestics**, Shirtings, Printers, Wigans, Cambrics, Jaconettes, Lawns, Mulls, Madapollams, T Cloths, Long Cloths—

These are all plain calicoes. Domestics are similar to T-cloths, woven with heavy yarns, sized, but made in longer lengths.

Woven on an ordinary plain loom; under-tread for two shafts; loose or fast reed, according to weight.

**Doria Stripes**—

Fabrics in which stripes are formed by cramping the warp in the reed. Woven on plain looms.

**Drilletes**—

Twills, five-shaft, about 41 inches, 64 yards.

**Flannelettes**—

Cotton fabrics with a raised surface (raised after weaving). May be raised on one side or both sides.

**Fustians**, Cords, Swansdowns, Lambskins, Moleskins—

These are all heavy goods, with most of the weft at the back.

Woven on heavy looms, with one shuttle, fast reed, negative take-up motion, and plate or woodcroft side tappets.

**Herring-bones**—

Twills, with ribs running in opposite directions.

**Italians**—

Very fine sateens. Woven on sateen loom.

**Jaconettes** (See under Domestics)—

Plain cloths, about 20 yards in length.

**Jeans** (See under Regattas)—

Three-shaft twills.

Woven on plain loom with tappet motion.

**Lambskins** (See under Swansdowns)--

Cotton fabrics, raised on one side.

**Lawns**--

Very fine fabrics, from 60's or finer yarns.

Woven on plain looms.

**Leno, Fancy Cloth**

The warp threads are worked in pairs, and are twisted half a turn between each pick.

Woven on tappet or dobby looms, with specially constructed healds, known as "Doup" healds

**Madapollams** (See under Domestics)--

Plain cloth, about 32 inches, 48 yards, with coloured heading in middle; average reed and pick, about 12 by 12.

**Mulls** (See under Domestics)--

Similar to jaconettes, but woven from finer yarns.

**Muslins, Hair and Crammed**--

Plain cloths, but with threads of two or more folds running through the warp.

**Oxford Checks, Harvards, Zephyrs, Flannelettes, Gingham, Checks, Handkerchiefs, Dusters, Scarves, Sarongs**--

Woven on looms of medium weight; drop-box or revolver shuttle-motion; fast or loose reed; plain under-tread; side tappet or dobby. The last four are cross-bordered goods, and require a card-saving motion.

**Oxford Stripes, Harvards, Zephyrs, and Flannelettes**--

Same as above, but lighter in weight.

Woven on a loom of medium weight; either fast or loose reed, under-pick or over-pick; side tappet, under-treads, or dobby, to suit weight.

**Regattas, Ticks, Nankeens, Jeans, Denims, Dungarees, Coutils, Satins or Sateens, and Grandrills**--

All rather heavy striped and self goods.

Woven on a strong loom (often under-pick); fast reed; side tappet for heavy makes, dobby for light.

**Sateens** (See under Regattas)--

Broken twill fabrics, five-shaft.

**Serges**--

Twills, with from six shafts upwards, making diagonal stripes. Woven on dobby loom.

**Splits**--

Two pieces of fabric woven side by side in one loom, with locking ends to form selvages.

Woven on plain calico loom.

**Swansdowns** (See under Fustians)--

Cotton fabrics raised on both sides. ("Lambskins" are raised on one side only.)

**T Cloths** (See under Domestics)--

Plain cloths from heavy yarns, sized; made in 24-yard lengths.

**Tanjibs**--

Plain cloths, about 12 by 12 to about 14 by 14, with two lilac, red, and cord headings in the middle.

Woven on calico loom.

**Turkish Towels**--

Woven on a special loom; two yarn-beams; loose reed; dobby or other fancy tread motion.

**Twills**--

Diagonal weaves.

Woven on plain loom with four-shaft tappet.



SECTION VIII:

BLEACHING

MERCERISING, DYEING

FINISHING, &c.

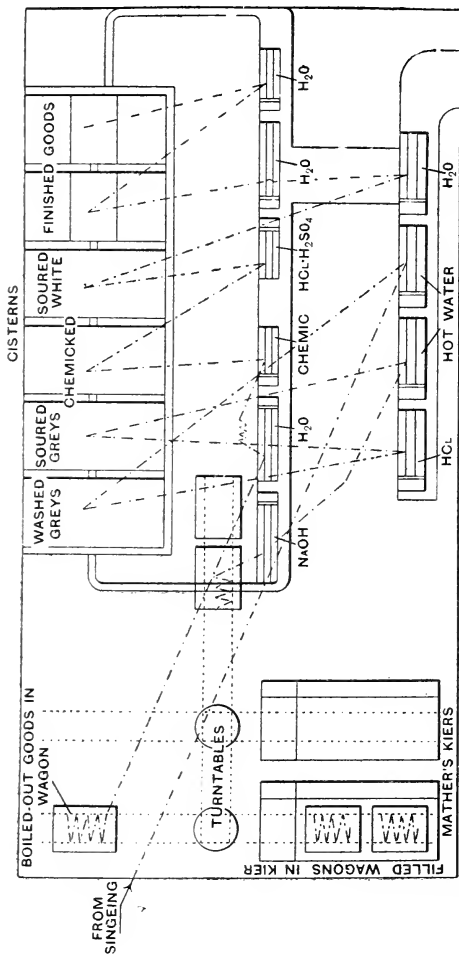

SEQUENCE OF MACHINES FOR BLEACHING AND WHITE-FINISHING COTTON PIECE-GOODS.—  
 Showing one Machine for each step in the process. (Dash and dot lines show course of cloth.)

## BLEACHING

The bleaching of cotton materials is nowadays carried out at all of the usual stages of manufacture—those of raw cotton, slubbings, rovings, cops, cheeses, hanks, and warps, as well as pieces.

By far the greater quantity, however, is bleached in the woven state, though each of the other resources has its special recommendations for particular requirements. Cotton is bleached in the loose state in occasional instances for the preparation of absorbent surgical and general wadding and such like purposes; and in other instances for the preparation of gun-cotton, or simply with the object of cleansing it—as, for instance, in the

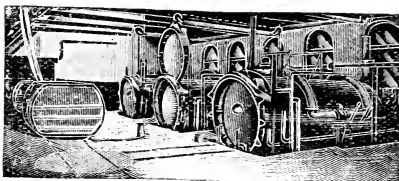

case of dirtied waste, for the sake of reworking. According to the purpose for which the loose cotton when bleached is designed, varying degrees of care are called for in manipulation, though for the most part the possibility of matting the fibres has to be guarded against. This is minimised by dispensing with the boiling or wetting-out operation, and by soaking instead for a time in a tepid solution of soap or turkey-red oil.

Bleaching in the hank, warp, cop, and cheese forms, is done for the production of woven goods, sewing threads, crochet yarns, laces, embroideries, and similar fancy articles.

**Bleaching Agents.**—There are more methods of bleaching available than the time-honoured chloride of lime bleach, though it is still the most successful, considered generally with regard to cost and results. These, however, find application within very narrow limits, and on the grounds solely of special adaptability to unusual circumstances.

Instead of using the ordinary chloride of lime bath, on account of the impurities held in it, and also at

times because of its over-energetic action, the comparatively pure and less energetic hypochlorite of soda is accorded occasional preference, as well as baths of chlorine prepared by the electrolytic dissociation of a solution of sodium chloride. Moreover, the employment of chlorine is not altogether indispensable, inasmuch as satisfactory results, relatively to the modest nature of the demands made, have been obtained with hydrogen peroxide, and the peroxides, and also with permanganate of potash cleared by bisulphite of soda. The matter of cost, in relation to efficiency, governs the selection.

**Manipulation.**—The method of working is subject to wide modification, according to the nature of the bleaching agent employed, and especially to the state of the material under treatment; but substantially it consists in two stages—first the boiling-out, for the purpose of loosening or even removing the natural impurities and the second the bleaching of the fibre. In the case of loose cotton, cops, cheeses, and hanks, the first may sometimes be dispensed with, but with a corresponding sacrifice in the quality of the end results.

The boiling operation may consist of treating the material according to its form in becks, machines, open kiers, or closed high or low pressure kiers with boiling water, either alone or with the addition of various approved alkalis. Each course obviously has its own recommendations, and is dependent for application as much on the texture as on the amount of impurities of natural colouring matter present in the particular form of material: slightly coloured cottons, lightly twisted yarns, and lightly woven goods do not call for the same course of treatment throughout as highly coloured, lightly twisted yarns, and heavily woven and sized goods. Experience has shown, however, that for the production of as good a white as possible on both yarns and pieces great attention should be paid to the operation of boiling-out, and for this reason this should be accomplished in a closed low or even high pressure kier. It reaches the highest degree of importance when the production of what is termed a market white for piece-goods is under consideration.

**Preliminary Operations.**—Generally speaking, no regular form of preliminary preparation antecedent to the boiling-out operation is called for in the treatment of those forms of material other than cloth, with the occasional exception, of course, of steeping in water, or of

gassing, in the case of yarns, when called for, but for piece-goods there are many operations leading up to it.

### BLEACHING YARNS.

The bleaching of small lots of yarn in dye-houses, for white or for dyeing in bright shades, and in manufactories for weaving, is necessarily carried out somewhat differently from the continuous treatment of large lots, since the same elaborate and conveniently-situated mechanical arrangements are not at hand—on account of their cost in relation to the amount of material treated being not usually warranted. In any case the provision of a closed kier, preferably fitted with means for causing the circulation of the liquor during the treatment of the yarn, is necessary for the most satisfactory results in quality of white and in economy of steam. The use of an iron kier calls for care in preventing the formation of iron-stains on the yarn, especially when a new kier is to be used for the first time, and this is simply done by applying a thin coating of lime to the inner surfaces of the kier. It is beneficial to add a certain amount of alkali to the water in which the yarn is boiled, and in these circumstances no scum or dirt should be allowed to enter the kier. This observation calls attention to the quality of the water supply. With a soft water free from lime, no difficulties are encountered; but with hard calcareous waters, precipitates are formed upon boiling with alkali, and stains occur on the yarn. Condensation water is admirable for bleaching purposes, but since this too is liable to contain impurities (mineral oil), the water should be first boiled up with the requisite quantity of alkali in a separate vessel.

The proportion of the alkali depends upon the quality of the yarn: for 200 lb. of yarn, from  $4\frac{1}{2}$  to 9 lb. of calcined soda; or  $2\frac{1}{2}$  to  $4\frac{1}{2}$  lb. caustic soda; or  $4\frac{1}{2}$  to 9 lb. silicate of soda (30 deg. Bé.); or a mixture of soda and silicate of soda. Care requires to be exercised in packing the yarn in the kier, and this operation should be done in such a manner that no spaces are left for the circulating lye to form channels rather than passing through the mass of the yarn. When evenly packed, the yarn is covered over with a sheet of hessian cloth, and rods of whitewashed iron are laid across to keep it in position. It is important that the yarn should be below the level of the liquor in the kier. After boiling-out, the yarn is washed well preparatory to chemicking, or even soured,

and, of course, again well washed, according to the quality of the yarn and the degree of hardness of the water in use.

For souring at this stage a warm, weak bath of sulphuric acid is employed with soft waters, and of hydrochloric acid with hard waters. For the treatment with chloride of lime, a wooden vessel with a perforated false bottom is usually provided, coated with lead or cement. Besides chloride of lime, hypochlorite of soda is also used, especially for the fine and better qualities of yarn, prepared either electrolytically or by precipitating with soda from the chloride of lime solution. Chloride of lime is liable to form into particles upon mixing with water, and as this is to be avoided, special mixing cisterns, with mechanical agitators, are usually provided. The conveyance of the prepared bleaching liquor to the vessels where it is needed for use is generally accomplished by means of small centrifugal pumps of lead or phosphor-bronze, and lead pipes.

In addition to the settling tank and the vessel in which the yarn is treated, it is advisable to provide another—a mixing reservoir—so as to admit of catching the bleaching liquors for further use, after suitably replenishing. Solutions varying from  $\frac{1}{2}$  to  $1\frac{1}{2}$  deg. Bé. are used for steeping the yarn; the liquid should be circulated for a period ranging from two to five hours. At the end of this operation the liquor is either allowed to run away or is pumped into the mixing reservoir, and the yarn then thoroughly washed and soured; for cheap sorts of yarn and soft water sulphuric acid  $\frac{1}{2}$  to 1 deg. Bé. should be used, and for fine sorts and hard water hydrochloric acid. The sours is first made up in a separate vessel, transferred to the vessel containing the yarn, and then caused to circulate for two or three hours. If any odour of chlorine is appreciable during the souring operation, it points to the fact that the preceding washing had not been thorough enough; and as the development of free chlorine in this way is liable to damage the fibre more or less pronouncedly, immunity against trouble from this cause may be gained by adding to the sours a small quantity of a solution of bisulphite of soda. When the bleaching bath is composed of hypochlorite of soda this is not actually necessary, yet something is to be gained in the greater purity of the resulting white by giving a weak sours to the extent of about half the strength used when chloride of lime has been employed; with a very soft water, bisul-

phite alone answers satisfactorily. After the souring operation the yarn must be washed until no trace of acid is left behind, using litmus paper as the indicator. The washing is then continued on the machine, and is followed either by soaping or blueing, and finally centrifuging. Some importance is attached to the drying operation, and whether it be carried out on machines or in the stove, it is not usually advisable to allow the temperature to overtop 60 deg. C.

[For particulars regarding the effect of bleaching on the weight of yarns, see p. 292.]

### BLEACHING PIECE-GOODS.

With due regard to the texture of the goods, the manner of working cotton pieces depends upon whether they are to be bleached for printing, for dyeing with alizarine, or for a market white. The average qualities of cloths are worked in the rope form, while very heavy goods, such as moleskins, are most successfully bleached, even for dyeing, when treated throughout the several processes at full width. In the latter case, of course, special machines are required, particularly for boiling-out, for which a number of suitable kiers are in use.

#### Series of Operations.

##### (1) Marking and Stitching—

The pieces are joined end to end, so that the material can be put through the different processes continuously without entanglement and without incurring needless labour. For this purpose sewing machines of a special kind are employed. The thread used is of a soft nature, which will not cut the cloth even when passing between rollers under heavy pressure; and while the stitching will endure great tension, the threads can be easily drawn out when it is required to separate the pieces.

The machines employed are made to work by hand, treadle, steam, or electric power, and are invariably portable, so as to be readily removed from one place to another.

##### (2) Shearing and Moting—

Removes the loose fibres, motes, husks, and ends of yarn usually found on cloth as it comes direct from the loom. The shearing or cropping is performed by revolving cutters, which work against "ledger" plates. The cloth is then cleaned by rotary brushes, and an apparatus is provided for plaiting the material down ready for removal.

**(3) Singeing—**

This preparatory operation may be performed by means of hot plates, hot revolving rollers, or by gas flame.

**Hot Plate System.**

The cloth is singed by being passed over the surfaces of two or more semi-circular plates, kept at a great heat by burning fuel—coal or oil. To work effectively, the whole surface of the plate should be utilised, and this is achieved by means of a traverse motion, which brings the cloth to bear momentarily on different parts of the plate surfaces.

**Hot Roller System.**

This is a modification of the plate system. Instead of passing the cloth over the fixed plates, it comes into contact with the surface of a copper or cast-iron tube, through which the fumes of the fire are allowed to pass, and which revolves slowly. This system is well adapted for singeing such pile goods as velveteen, etc.

**Gas System.**

Instead of passing over heated plates or rollers, the cloth encounters a gas flame. The cloth to be singed passes across a slot in the underside of an exhaust chamber, connected to a fan, while the flame of the burner is drawn gently through the cloth by the current of air set up by the fan. This system is considered the most effective, expeditious, and economical, and is strongly recommended by practical men.

Gassing machines are also made specially arranged for the treatment of yarns.

With pieces, the foregoing are regular operations, and it is after singeing that variations come into vogue.

For the three classes named the following, though varied in many works, fairly represent the subsequent order of procedure:—

**FOR ALIZARINES.**

- (1) Boiling in water.
- (2) One or two caustic-lye boils.
- (3) Soured and washed.

**FOR PRINTS.**

- (1) Steeping in sours and washing (optional).
- (2) Lime boil.
- (3) Sours.
- (4) Soda-ash boil.
- (5) Chemic.
- (6) Sours and wash.

*(See Diagram on next page.)*



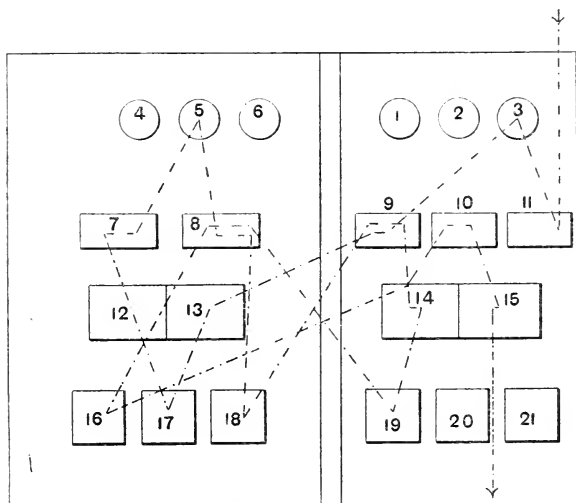

SEQUENCE OF MACHINES FOR PRINT CLOTH.  
(Dash-and-dot lines show course of pieces.)

- |  |                          |
|--|--------------------------|
| 1, 2, 3, are Lime Kiers.               | 4, 5, 6, are Soda Kiers. |
| 7, 8, 9, 10, 11, are Washing Machines. |                          |
| 12, 13, 14, 15, are Cisterns.          | 17 is HCl.               |
| 16 and 18 are $H_2SO_4$ .              | 19, 20, 21, the Chemic   |

#### MARKET WHITES.

- |                  |             |
|------------------|-------------|
| (1) Hot water.   | (5) Wash.   |
| (2) HCl sours.   | (6) Chemic. |
| (3) Water.       | (7) Sours.  |
| (4) Caustic boil | (8) Wash.   |

(See Diagram, p. 266.)

#### Bleaching Kiers.

Bleaching Kiers are constructed in a variety of forms, and their efficiency depends largely upon adaptation.

#### CIRCULATING KIERS.

The circulation is maintained by means of a special injector, which produces a rapid circulation of the boil-

ing liquor, with a small consumption of steam. Used in sizes up to 7 feet diameter. Arranged to work at either high or low pressure.

#### LOW-PRESSURE KIER.

Specially adapted for yarn or cloth where it is preferred to bleach at low temperatures, and where time is not a consideration. The circulation of liquor is produced by means of a puffer pipe and a steam jet, or by an injector.

#### Roller Washing Machines.

The bleached cloth is passed through this machine in rope form. The driving of the squeezing rollers is usually by friction clutch and pulley, and provision is made for regulating the pressure put on by the top roller.

#### Starch Mangles.

Usually made with one brass and two sycamore bowls, mounted in slide blocks, adjustable by vertical screws. The bottom bowl is partly immersed in the starch trough, and as the cloth leaves the machine the superfluous starch contained therein is removed while passing between the nip of the rollers.

#### Drying Cylinders.

Made with two rows of cylinders, one above the other, arranged horizontally or in tiers, and supported by columns when the space available is limited. They are fed by the cloth passing through expanders. The cylinders are steam-heated, and the cloth passes under and over each one alternately. At the delivery end the cloth is plaited down by an ordinary oscillating apparatus.

#### Belt Stretching.

For stretching the cloth in order to obtain its utmost width before calendering and finishing, the stretching pulleys are covered with perforated brass or indiarubber, and can be adjusted by means of regulating screws.

#### Beetling Machine.

The cloth having been wound upon cast-iron beams, it is subjected in this machine to a rapid succession of elastic blows from a series of hammers. The hammers work vertically, and each hammer head is suspended on belts tightly stretched round C springs. As the beetling

proceeds, the beam carrying the cloth is slowly started and moved end-ways in its bearings by suitable mechanism.

**Speed.**—Crank shaft, 380 revs. per min.

## MERCERISING

The mercerising of cotton is now such a successful process that the lower qualities of silk goods have been put out of the market. A large proportion of embroidery crochet cotton and sewing cotton is now mercerised; dressmakers and milliners find that mercerised cotton thread is suitable for most purposes for which they previously used silk; and, as it can now be had in black and white and a great variety of colours, it is correspondingly largely used. These colours have such a good lustre that they are scarcely distinguishable from silk.

Mercerisation is carried out on yarns, for the most part in hank and warp form, and on pieces. The maximum degree of lustre is obtained under tension by the use of Sea Island cotton, and also well-selected varieties of Egyptian cotton, when combed in spinning and gassed before mercerisation. The shorter-stapled cottons, even good American grades, acquire a fair degree of lustre when they have been specially prepared. Most yarns, after being specially spun and gassed, are doubled, though single yarns are occasionally treated, with regard to the fact that the less the twist the greater the lustre of the yarn, and, of course, the better the cotton the less the twist that may be put in.

### Twist in Yarn.

All yarns for mercerisation should be specially spun and doubled with the least amount of twist in that will answer the purpose for which the yarn is to be used. The less the twist, the greater will be the lustre of the yarn; and the better the cotton, the less the twist that may be put in. The following quantity of twist in yarn may be considered right for most purposes:—The yarn may be spun with four times the square root of the counts of twist in per one inch. If the yarn is 36's then—the square root of 36 is 6, and  $6 \times 4 = 24$  twist in one inch. When 36's are doubled twofold the counts are  $36 \div 2 = 18$  and the square root of 18 is 4.243; this may also be

multiplied by 4, and  $4.243 \times 4 = 16.972 =$  twist in one inch of  $2/36$ 's. Twist in  $3/36$ 's may be treated similarly.

$$3 \text{ } 36\text{'s} = 12 \times \sqrt{12} = 3.464 \times 4 = 13.856;$$

13.856 is the twist in 1 inch of  $3/36$ 's. The quality of the yarn and the twist put in must always be sufficient to stand the great strain put upon it by the caustic soda bath.

### Process and Principles.

The operation of mercerising includes three main phases:—(1) Impregnation of the material with the alkali; (2) washing; and (3) neutralisation of the alkali; and these are added to variously in almost all works to meet existing conditions. Boiling-out is generally the first step, although in occasional instances, when dealing with certain qualities of cloth, it is not resorted to. Hanks are boiled out under low pressure, while warps are passed through a boiling-out machine in the customary manner. Both forms of yarn are occasionally dried up after washing, before coming into contact with the mercerising liquor.

The principles involved in the control of the mercerising bath are the same for both yarns and cloths. They depend upon the temperature of the bath as well as upon its degree of concentration, and also upon the state of the material, wet or dry. When employed at a strength from about 42 deg. Tw. to 56 deg. Tw., and used regularly and continuously at the same strength, the temperature of the bath should not be allowed to exceed 30 deg. C. At lower temperatures the strength may be relatively decreased within certain limits. Generally considered, the duration of contact of the alkali with the cotton is regarded only as a matter of secondary importance, excepting in certain systems of treating pieces, when the contact is allowed to continue for many hours. For most purposes a treatment extending over two to five minutes is considered necessary to give the maximum of results.

The first washing is an operation as important as any, and should be accomplished while the material is still under tension. After this souring and washing follow, should the goods be finished or required for dyeing with any other colours than the substantive and sulphide dye-stuffs. In the latter circumstances, and when the material is required for bleaching, souring is not carried out.

More or less effective machines exist for creating and maintaining the necessary tension. For most part these

vary somewhat in each works, though automatic static, dynamo-static, and astatic contrivances are general. All these forms are in use for the treatment of hanks. Warps are most successfully mercerised by passing in the rope form through an adapted warp-dyeing machine of several compartments. The treatment is continuous. This form of yarn is likewise successfully treated at full width by passing through a slasher-like machine with a series of wide compartments.

**Observations.**—Yarns of certain qualities and for certain purposes are sometimes gassed after mercerisation as well as before, so as to enhance the lustre. The gassing applied to yarns and the singeing to cloth should be carefully carried out, and burnt places or flame-marks avoided.

When dried in the stretched condition, mercerised yarns show an appreciably better lustre than when dried in the loose state. A course of stringeing on specially constructed machines, or such as are employed for the lustring of silk, is also occasionally resorted to. Except for the production of special finishes, it is most practicable to allow the bleaching operation on both yarns and pieces to follow that of mercerising.

#### **Gassing.**

If the yarn is "gassed" to take off the loose fibres a better lustre is obtained.

#### **Boiling.**

Before mercerising, the yarn must be well boiled in a closed boiler for four hours at not more than 5 lb. steam pressure. It must then be well washed off in cold water until all impurities are cleared away, when it may be well wrung out or extracted. If for bleaching or dyeing, it is better to mercerise the yarn first.

#### **Caustic Soda.**

The caustic soda bath must be kept up to 60 deg. Tw. It need not be stronger, but a solution at 70 deg. Tw. must be kept at hand, so that, as the bath gets weaker with the wet yarn passing through, or working in it, it may be strengthened up, as is found by frequent testing to be necessary to keep the working strength at 60 deg. Tw. If the strength gets to 55 deg. Tw. the result will be very poor, and if to 47 deg. Tw. it will be of no use

at all. Caustic soda can be obtained in solution of the strength required, or solid in cakes; 2lb. 6oz. of the latter will make about one gallon of solution at 60 deg. Tw. As caustic soda acts smartly on the skin, it should be well washed off the hands until all slipperiness is gone. Good aprons should be worn by the workpeople, or the splashes, if allowed to dry on the clothes, will make holes.

#### **Tension of the Yarn.**

Whether the mercerising is done in the hank or in the warp, the yarn must be kept at one tension throughout, and so spread out that one thread is not tighter than another. The secret of obtaining a silky lustre on cotton yarn is keeping it well on the stretch while in the caustic soda. It should be the same length after mercerising as in the grey, and must not be shorter—though it may be 2 per cent. longer without injury. The tension is so great when the yarn has got well wetted out in the caustic soda, that the bearings must be strong and well fixed. Without this tension the yarn would contract one-fourth of its original length.

Five minutes should be allowed for the yarn to remain in the caustic soda bath. There is no advantage in prolonging this, though it might go to seven minutes. But to obtain like results the time must be always the same, and all parts of the yarn must be wetted alike.

The temperature of the bath must be kept always the same. The colder the better, say 60 deg. F.—no higher. If there is any difficulty in getting it down, ice must be used, so that it is the same all the year round, thus making the results uniform.

#### **Washing.**

The yarn must be kept at a tight tension until it has been washed. As a good deal of caustic soda is carried away from the bath, the yarn should be washed first with a little water, which can be used for making up a new solution of caustic soda. A good wash with cold water follows, taking care that the threads do not get entangled. If any soda is left in the fibre it will cause further shrinkage and the yarn will lose some of its lustre.

If the yarn is to be used immediately for bleaching, or dyeing with such colours as benzo purpurines, it need not be put through an acid bath.

### The Acid Bath.

Souring-off is generally done in a bath of sulphuric acid at 1 deg. Tw. After souring, the yarn must be thoroughly washed. If the least acid is left in, the yarn will go tender, and, if subjected to heat, will become rotten. If a little water wrung from it after washing does not taste sour it will be all right. A running stream of water is good for the final washing. The yarn is then extracted and dried in a hot-air chamber, and it looks better if it can be kept gently on the stretch while drying.

When all the conditions necessary for good mercerising have been fulfilled, the results will be always alike and the average strength of the yarn will be increased 30 per cent. It will also have a silky lustre, and will have gained about 5 per cent. in weight. Mercerising does not destroy the elasticity of the thread—it retains four-fifths of the elasticity of the grey.

### Dyeing.

Mercerised yarns take up the dye so readily that weaker solutions have to be used in order to get a level dye, and about 14 per cent. less dye wares are used. The colours retain their silky lustre after dyeing and bleaching.

The dyebath should not be worked at more than 160 deg. F. for yarns that have been mercerised. Tannin and tartar emetic mordants, metallic salts, and alum, somewhat dull mercerised yarn, and so are only used when nothing else will answer. Soap is used with some dyes—such as the benzos; but no more than 1 lb. should be used to each 20 gallons of dye liquor.

Very careful manipulation is necessary, so that the results may be uniform throughout a long period.

### MERCERISING CLOTH.

In mercerising cloth, the material may be taken directly from the singeing room, or it may be scoured or half-bleached before going through the mercerising range. The latter course is recommended, because in the grey the cloth contains a certain amount of size, which has a tendency at times to neutralise the caustic soda. Moreover, when treated in the grey state, extra caustic soda is required to keep the bath to its proper degree of strength, which is more expensive than first scouring to remove the size. The latter system also ensures a more uniform finish to the goods after they have been dyed.

Stress of competition in the mercerising industry has paved the way for the realisation of all possible forms of

economy in working, and great attention has been devoted to means for effecting the recovery of as much as possible of the caustic soda from the lye, because loss permitted there might be very great. Two or three types of apparatus have been in use for many years for concentrating the mercerising lye after use to at least a state of density suited for re-use, but these, on account of their initial cost, can only come into requisition in instances where a very large output is concerned. In such cases these apparatus have more or less earned interest on the capital laid out in them, but they do not effect the amount of economy that has been more and more demanded during recent years. Consequently various proposals, both of a mechanical and a chemico-physical nature, have been brought forward, and in some cases have been adopted industrially to minimise the loss of caustic soda. Those of a mechanical order comprise, for the treatment of cloth, the provision of scrapers and rollers on the mercerising range to come into contact with the impregnated cloth previous to washing, thus removing before washing more of the strong caustic lye than formerly; another method supplies steam to the impregnated cloth in place of the first washing for the removal of the caustic, with the lesser possibility of unduly diluting the alkali. Another is a sort of suction device for extracting the alkali before washing. All these processes have secured practical application.

Other proposals are concerned with the particular form of treatment for the purpose of utilising the spent lye, which generally stands with the first wash-water at a density of 6 to 8 deg. Tw. Where the expense of concentration plants is out of the question (these instances are common), various suggestions have been made lately for the solution of the problem of cheaply and effectively recovering or utilising the alkali. Success has attended some of them. The problem loses some of its difficulty when bleaching is an operation carried out at the same works, for then the used lye may be utilised for the kier-boils, and some portion of it even for the manufacture of soap where large quantities of that product happen to be required. But there may be no bleach-house to consume the lye, or that department may not be large enough to take all of it.

Anyhow, other suggestions consist of advising the conveyance of the spent lye for concentration to an ordinary



steam-generating boiler, provided with iron fittings, and therein driving off the water from successive lots, in the form of utilisable steam.

Another method purposes getting rid of the impurities which by partial evaporation of the lye necessarily accumulate, to obvious disadvantage. This is accomplished by boiling the lye with a mixture of lime and ordinary soda, thus precipitating the organic impurities and at the same time manufacturing caustic soda.

### MACHINES.

Whether the material be treated in the yarn or woven state, the machinery employed is usually in the form of

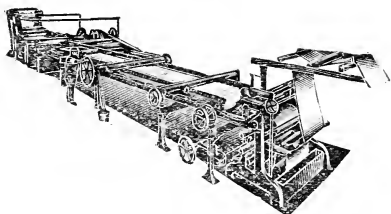

a range of sequence of machines, set to work in continuous order, finishing up with a drying apparatus.

#### Machines for Warp Yarn.

Mercerise, size, and dry the yarn as it is being run on to the loom beam.

**Speed.**—15 to 20 yards per min.

**Pulleys.**—20 in. dia.  $\times$  4 in., 120 revs. per min.

**Power.**—8 I.H.P.     **Floor Space.**—60 ft.  $\times$  9 ft. 3 in.

#### Machines for Hank Yarn.

These are provided with screw stretching devices for the hanks, and are self-contained.

**Speed.**—Machine 500 revs. per min.

**Speed.**—Screw 225 revs. per min.

**Pulleys.**—18 in. dia.  $\times$  3½ in.

**Floor Space.**—10 ft. 6 in.  $\times$  7 ft. 6 in.

Various contrivances are in vogue for the treatment of piece-goods, but the range generally comprises the following:—

### Padding Machine.

In this machine the cloth is immersed in the caustic soda bath, in a loose state. It is provided with a pair of squeezing rollers, the pressure of which is adjustable. When a second or third bath is required, the squeezing rollers are duplicated.

**Speed.**—240 revs. per min.

**Pulleys.**—30 in. dia.  $\times$  6 in. wide.

### Stentering Machine.

Takes the cloth directly or subsequently from nip rollers of the padding machine. Length from centre of clip chain-wheels, about 50 feet. Self-feeding clips are provided to stretch out the cloth to its full width.

**Speed.**—216 revs. per min.—25 yds. of cloth.

**Pulleys.**—24 in. dia.  $\times$  5 $\frac{1}{4}$  in.

**Floor Space.**—54 ft. 6 in.  $\times$  12 ft.

When the cloth is sprinkled, besides being immersed, the machine is provided with overhead sprinkler pipes.

**Speed.**—138 revs. per min.—20 yards.

**Pulleys.**—24 in. dia.  $\times$  6 in.

**Floor Space.**—54 ft. 6 in.  $\times$  11 ft. 6 in.

### Washing Machine.

A machine of three or more compartments connects with the stenter wherein the cloth is washed and soured or otherwise treated.

### Drying Machine.

Is usually made with 24 cylinders arranged in two rows and of a width to suit the cloth to be dried. This machine is provided at the delivery end with a plaiting-down arrangement of the ordinary type.

**Speed.**—Variable.

**Pulleys.**—Variable.

**Floor Space.**—30 ft. 6 in.  $\times$  10 ft. 9 in.

Total length of range 120 feet.



SEQUENCE OF MACHINES FOR MERCERISING AND DRYING COTTON.

**Drying Mercerised Materials.**—The conclusions drawn from experimental evidence—as given by Dr. Knecht before a recent gathering at Manchester of members of the Society of Dyers and Colourists—in regard to the influence of drying on mercerised cotton, are that it is undoubtedly affected very materially in its affinity for colouring matters. It was shown that mercerised cotton dried evinced less affinity for dyestuffs than when dyed without previously drying. On this observation the other conclusions are:—(1) Light places in dyed mercerised goods hitherto ascribed to oxycellulose may frequently be traced to uneven drying, especially of selvages, which would dye a lighter shade than the rest of the piece. On the other hand, it is seen that dark stains may result from the mercerised material being accidentally impregnated with some hygroscopic substance previous to drying. Such faults are difficult to remedy, the best means being remercerisation of the whole piece. (2) In order to get the full benefit of increased affinity for dyestuffs, the goods should be dyed at once after mercerising, without previous drying. (3) To preserve the full affinity of mercerised goods for printing, impregnation previous to drying with a solution of some hygroscopic substance like glycerine is recommended. (4) It affords a possible explanation why caustic soda mercerises better cold than hot. (5) It should be borne in mind that the factor of temperature in drying has a great influence on any chemical test applied to detect mercerised cotton or to estimate the degree of mercerisation.

## DYEING

The dyeing of cotton is carried out at any stage of its manufacture, with a corresponding call for variation in the mechanical means employed. The nature of the colouring matters to be applied also modifies the mechanical side. Of late years the practice of dyeing yarns in forms other than hanks has grown considerably—not only on account of the economy in cost of production, but also through the gradual introduction of a whole range of colouring matters faster than the majority of the direct dyes, and almost as readily applied. Warps, too, are not now only dyed in the rope-form in the stereotyped roller-and-squeezer machine, but frequently at full width through slasher-like machines, and also in the beam state wound on strong perforated tubes; they are likewise sometimes treated in the compact ball in special machines.

Many specially constructed machines are in use for the treatment of loose cotton, slubbings, rovings, cops, cheeses, and beams, modified according to the nature of the colouring matter—direct, basic, mordant, sulphide, or indigo. Very few changes have come about in the ways of manipulating pieces other than supplementary forms of treatment necessitated in the application of some of the more recent dyes.

### COLOURING MATTERS, PROCESSES, ETC.

Some of the old colouring matters are still retained for use, notably (among the natural family) logwood, fustic, and indigo; and (of the mineral colours) chrome yellows and oranges, as well as iron buff, and the comparatively modern combination of it with chromium oxide—khaki. Outside of these, the other natural and mineral colours are seldom employed, and have given place almost entirely to their betters.

Beyond the many spheres of usefulness of those classes of dyestuffs known respectively as the direct, basic, acid, mordant, developed, coupled, and azo dyes, the last few years have seen the appearance of many improved forms of the sulphide members, besides the augmentation of this range to the extent of including almost the whole gamut of possible shades. Furthermore, the appearance of the indanthrenes, the ciba blues, and the thioindigos, has greatly extended possibilities in the production of bright and extremely fast colours.

The improvements set afoot by the makers of artificial indigo in the methods of applying indigo, in its proper manner of reduction, and the ways of carefully controlling the vats, are all features which have simplified some previous difficulties, and at the same time have made it more and more unlikely that any other blue colouring matter may successfully compete with indigo.

### Recent Progress in Colour Work.

Cross and Briggs have worked out a method for the previous treatment of the cotton fibre in such a manner as to cause it to resist dyeing with the direct dyestuffs. Their process consists in treating the cotton with a mixture of acetic anhydride, acetyl chloride, glacial acetic acid, and zinc oxide, so as to acetylate the fibre partially. Though the cost of the work is high, the process

is said to have some special applications for the production of fancy dyed effects.

The hitherto little understood "dead cotton" has been the subject of some investigation by Haller. It is well known that this abnormal modification of the cotton fibre generally takes on a much weaker colour by dyeing than the normal fibre, and this feature is most particularly brought into evidence when applying indigo as well as the direct colours; yet it is pointed out that exactly the contrary effect is produced when the tannin-basic dyes are applied, the "dead cotton" being then deeper than the normal cotton.

Vieweg's announcement some time ago, that an addition of common salt to the caustic soda liquor for mercerising caused the fibre to absorb the caustic soda much more readily, received much attention, and, more recently, contradiction. Hubner, and also Knecht, have shown that instead of the common salt acting beneficially in increasing the degree of mercerisation, it acts in the opposite direction.

In the production of aniline black on cotton, Green's new method marks very important progress. The principle of the new process consists in adding a relatively small proportion of a paradiamine to the padding liquor and dispensing with the customary chlorates and other oxidising agents. The aniline may be present in the form of the hydrochloride or as a mixture of the hydrochloride and formate, and the copper not in the form of the oxide, but as a salt of cuprous oxide. To bring the last-named into solution, an excess of ammonium chloride is added to the padding liquor. The development of the black takes place in the ageing-chamber through the influence of the oxygen of the atmosphere, and chroming follows, as in the ordinary methods. The main advantages claimed for Green's process are that no tendering of the fibre takes place, and that 3 to 4 per cent. of aniline suffices to produce the black.

For fixing the direct colours on cotton Toepfer has patented a process of after-treatment, consisting in impregnating the dyed material with a solution of sulphate of magnesia; and then, in a second bath, with a solution of caustic soda and stannate of soda. To attain the same object the Basle Society of Chemical Industry

treat the dyed material with a solution of aluminium formate.

In printing the alizarine colours the fabric is previously oiled for the purpose of increasing the intensity, the beauty, and the fastness of the resulting colour. As it always has been necessary to prepare the whole piece with oil, the cost of production is high when small patterns are printed. Wilhelm has proposed to overcome this disadvantage by adding the turkey-red oil direct to the printing paste, and preventing the formation of insoluble compounds between the oil and the mordants by adding certain quantities of lactic and formic acid, besides a small amount of acetate of soda.

The past year (1909) has witnessed the introduction of many more new members to the valuable series of so-called vat-dyes, and with these (both singly and admixed) it is now possible to produce an extensive gamut of shades possessing extraordinary properties of fastness. Some of them are also very brilliant in shade, and although nothing can be said against these products as a series but the comparatively high cost to the user, there is very little visible indication at present of any possibility of that cost being lowered to an appreciable extent. For general purposes the vat-dyes are regarded as being too costly, and in the case of some members prohibitive in full dark shades, even for very special classes of goods. Yet for fine tints and light shades on mercerised cottons many of them are deserving of close attention, on account of their great fastness to washing, light, acids, and chloring.

Some interesting information has recently been published on ingenious methods, devised by Saget, for accomplishing the uni-colouring, by dyeing, of mixed fabrics containing cotton and viscose silk, and cotton, mercerised cotton, and artificial silk. Saget observes that the rate at which the substantive dyes are absorbed by viscose silk and by ordinary cotton falls as the temperature of the dyebath is lowered, yet the affinity of the cotton for the colouring matter varies less quickly than that of the viscose. In the case of dyeing a mixture of ordinary cotton with viscose silk at the boil, the latter becomes much more intense in shade than the cotton, but by choosing lower temperatures a point may be reached when, for the same dye, the affinity of the viscose is less than that of the cotton.

Different direct dyes behave in various ways; therefore, by a right choice of colouring matter dyed at a low temperature, it is possible to colour both fibres equally. For a uni-colour on both fibres the following dyes are applied at a temperature of 30 to 40 deg. C.:—Diamine Pure Blue FF, Diamine Brilliant Violet B, Diamine Green G, Diamine Pink FFB, Chrysophenine, Diamine Bordeaux B, Diamine Brown S, and Diaminogen Extra. Whereas for equal effects the under-named require to be applied at a temperature of 70 to 85 deg. C.:—Diamine Fast Yellow A, Oxydiamine Yellow TZ and GG, Thioflavin S, Diamine Orange G and DN, Diamine Fast Scarlet 4BN, Diamine Blue CVB, and Oxydiamine Blue G. Again, those just named, when applied at a temperature of 30 to 40 deg. C., colour the viscose silk much weaker than the cotton. When it becomes a question of dyeing equably a mixed fabric composed of ordinary cotton, mercerised cotton, and artificial silk, the resisting effect exercised by tannate of tin is brought into service by treating the fabric, after souring and washing, overnight in a 3 per cent. solution of tannin, fixing in a warm 2 per cent. bath of chloride of tin, and washing thoroughly; upon each fibre is thus fixed a quantity of tannate of tin different from the others. Upon dyeing, the affinity of the three fibres for the direct colouring matters is exactly the contrary to that evidenced by the non-prepared fibres, the ordinary cotton absorbing more colour than the others. To produce a uni-colour by this method, Saget adopts the ingenious device of making an addition of an alkali carbonate to the dyebath, which, by more or less prolonged action at a temperature of 80 to 100 deg. C., effects the partial removal of the tannate of tin previously fixed upon the fibres, and in that manner the affinities of the respective fibres for the colour is modified till a point is reached when each is dyed to the same depth. The same result may also be attained by the prolonged action of boiling water.

## DYEING APPARATUS

### For Loose Cotton.

Consists of a cistern provided with a centrifugal pump, the suction and delivery of which are connected to the under side of the cistern. Inside the cistern, and over the delivery of the pump, is fixed a conical seating, upon which rests a perforated cylinder containing the material to be dyed. This cylinder is formed of an

inner and outer perforated casing, between which the raw material is placed, the material being held tightly in position by means of a lid forced down by a screw. The cylinder consists of an inner casing with boxes of size suitable for containing the tops, the

boxes being fitted with perforated lids, which are easily removable. The apparatus is made with either iron or wood cisterns, and with iron or brass pumps and fittings. The perforated cylinders are usually made of copper; when required for sulphur colours they are made entirely of iron.

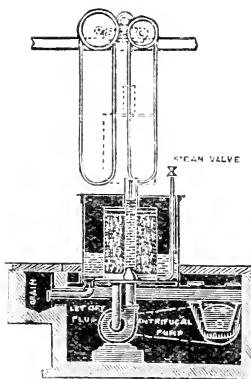

Dyeing is effected by the continuous circulation of the liquor through the cistern. The centrifugal pump forces the liquor through the inner perforated casing of the cylinder, then through the material, and finally through the perforations in the outer casing into the cistern, whence the pump draws the liquor; thus a continuous circulation is kept up. The cylinder is lifted in and out of the cistern by means of a small travelling crane; but in the case of a single apparatus, a runner and blocks will suffice.

The operations of mordanting, dyeing, and washing-off can be performed without removing the material from the cylinder. Thus matting or felting of the material is avoided, as it remains undisturbed during the whole process, and after dyeing and drying it retains its open and springy nature. The spinning quality of the material is better: it leaves the cards more easily, and less waste is caused, as compared with dyeing in an open vat, where the material is agitated and turned over by workmen with long poles.

The operations of mordanting, dyeing, and washing-off can be performed without removing the material from the cylinder. Thus matting or felting of the material is avoided, as it remains undisturbed during the whole process, and after dyeing and drying it retains its open and springy nature. The spinning quality of the material is better: it leaves the cards more easily, and less waste is caused, as compared with dyeing in an open vat, where the material is agitated and turned over by workmen with long poles.

### DYEING MACHINE

#### For Yarn in Cross-wound Spools or Cheeses

Consists of a cylindrical cast-iron cistern, in one side of which is a rectangular recess extending the whole depth of the tank. The top is closed by a water-tight lid. At the bottom of the tank is a circular iron plate mounted on a spindle, which passes to the outside of the



tank, where it is provided with worm gear for causing its rotation. Below this iron plate is a space through which a pipe runs in connection with a centrifugal pump.

The material to be dyed is placed in a perforated iron cylinder, which is lowered into the cistern, where it rests on the revolving circular bottom plate, and comes close up against the walls of the cistern. The lid being then closed and the pump started, the liquor is forced from the outside of the cylinder through the material in it, and down through the space under the bottom plate out of the machine. As the cylinder with the material therein is slowly rotated at the same time, successive portions of the material come in front of the recess whence the dye liquor issues. The liquor can also be made to circulate in the opposite direction.

#### For Yarn in the Hank.

Dyeing yarn in the hank may be performed either by hand or machine, but where large quantities of yarn have to be treated the latter is most economical and expeditious.

**Hand Dyeing.**—When the yarn is in small lots, bath tubs are used of such a depth as will take in the full length of the hank, when suspended from a stick and allowed to hang straight down. The sticks are placed horizontally across and are supported by the edges of the tub. The dye liquor in the tub is heated by steam passing through a pipe at the bottom. When large quantities of yarn are treated, rectangular vats or troughs are used in place of the tubs, but in other respects the process of dyeing is the same.

**Mechanical Dyeing.** — In the mechanical system the machines usually consist of two discs mounted upon a horizontal shaft, but at a suitable distance apart to form a skeleton cylinder. Arranged between these and extending from one disc to the other, are the sticks from which the hanks, to be dyed, are suspended. The bottom portion of the machine is in the form of a trough which contains the dye liquor. As the cylinder revolves the hanks of yarn are passed through the dye liquor.

**Production.**—Machines of the above kind will dye as much as 1,000 lb. of cotton yarn in 10 hours.

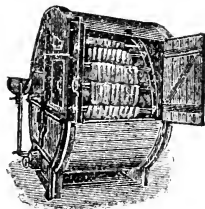

### For Yarn in the Cop.

All the processes of preparing, dyeing, washing-off, and extracting can be performed in this apparatus, which, in addition to the machine itself, consists of the necessary liquor tanks, valves, and connections. The machine is suitable for direct and basic colours, and is specially applicable for sulphur colours, as neither material nor liquor comes in contact with the atmosphere during the dyeing process. Boy or girl labour is sufficient for the manipulating of the machine and its valves.

The cops are fitted on perforated metal skewers or spindles, which are placed in the holes provided in the

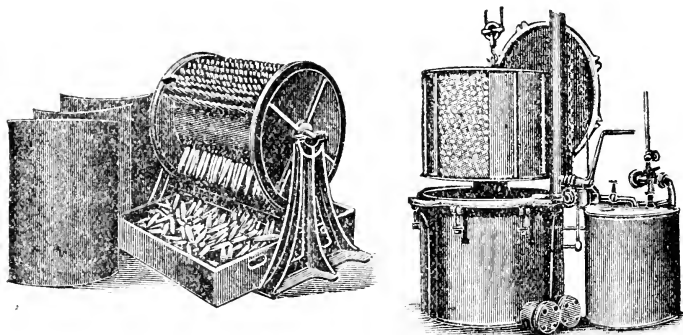

perforated cast-iron drum or cylinder. After being filled with cops, the cylinder is enclosed with a perforated casing made of special metal, and by means of a suitable arrangement is lowered on to a seating in the dyeing cistern, the lid of which is afterwards closed and bolted down.

The air is exhausted, by means of an ejector, from the dyeing cistern and receiver alongside it, which are connected by a pipe. The liquor is then allowed to flow from the liquor tank into both the receiver and the dyeing cistern, until they are more than half full. The steam is then turned on, and the liquor is forced out of the receiver into the inside of the drum or cylinder, through the perforated skewers and cops, into the cistern, the drum and material being completely immersed in liquor.

By an automatic arrangement operated by a float in the receiver, the steam connections to the receiver and dyeing cistern are now reversed, and the liquor is forced out of the cistern through the cops back into the receiver. This frequent reversal of the direction of flow of the liquor through the cops takes place during the whole process, thus ensuring even dyeing of the material. For dye liquors which are required to be used cold, a centrifugal pump, with the necessary pipes and valves, is provided, which allows of the frequent reversing of the liquor, as in the case of the arrangement where hot liquors are employed.

The cylinder containing the cops is removed from the dyeing cistern by the lifting arrangement provided, placed on its side, the outer perforated casing is removed, and the cops drop out into boxes, and are ready for the drying stove. These machines are made in various sizes, holding from 50 lb. to 130 lb. of cops at one time, the daily output depending upon the class of colours used, and the variety in the quantity of colours.

### DRYING.

To expedite the drying of the cops dyed on cop-dyeing machines, Extractors may be used. They are arranged to work with two air-pumps, fitted with foot-and-bucket valves. They produce a vacuum of from 25 to 26

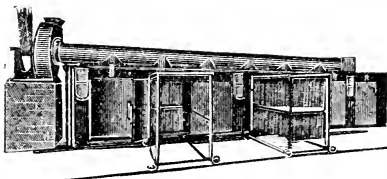

inches, and will extract from 60 to 70 per cent. of the superfluous liquor before the cops are placed in the stove to dry.

MACHINES are now made to take the place of stoves for drying yarn. One system consists of a number of drying chambers, each provided with its own heating compartment, the heating being effected by steam. The chambers are arranged to follow one another alternately, and heated air is passed through them, absorbing the moisture in the yarn and carrying it away. There are usually five chambers, and each one has its own inlet for the air, which may be closed at will by

suitable valves. Each chamber will take in from 11 to 12 bundles at a time, and the complete range will dry about 4,000 lb. of yarn in 10 hours.

By providing an additional compartment to each chamber, the above apparatus may be used as a Conditioning Machine as well as a dryer. The compartments added communicate with the outer atmosphere and with the chamber containing the material. By means of separate valves, one or more of the heating compartments may be cut off from circulation and the conditioning compartment contiguous thereto opened to the atmosphere. Through this compartment and the chamber containing the material the cold air is drawn for conditioning. When it is desired to apply more moisture to the material than is contained in the atmosphere, water jets are provided which combined form a fine spray to be deposited on the material.

**YARN-DYEING REGULATIONS.**—The Home Office has issued special regulations to apply to factories where the process of heading of yarn dyed by means of a lead compound is carried on, which process has been certified under the Factory and Workshops Act to be dangerous. "Heading" is defined as the manipulation of yarn dyed by means of a lead compound over a bar or post, and includes picking, making-up, and noddling. The Regulations are classed—"Statutory Rules and Orders, 1907: No. 616."

### VARIATION OF WEIGHT BY BLEACHING OR DYEING.

It may be generally taken for granted that the loss in weight of a good quality of cotton yarn through the ordinary bleaching operations is about 5 to 6 per cent., though short-stapled fibres containing motes and greasy impurities may lose as much as 8 to 9 per cent. in weight, when the amount of moisture present in both is about the same. The amount of moisture found normally in raw cotton is from  $7\frac{1}{2}$  to  $8\frac{1}{2}$  per cent., and yarns hold quite as much when not too thoroughly dried, or, on the other hand, when not damped. When light colours are dyed on bleached yarn the loss in weight occurring is due mostly to the bleaching, and as yarn for dark shades is mostly boiled first only with water, the loss in weight undergone is but 1 to 2 per cent. The yarn is not boiled, but wetted-out simply by adding a soap or

turkey-red oil to the dyebath, this loss is avoided; yet when strongly alkaline boiling dyebaths are employed, as in the case of the sulphide dyes, a loss of 4 to 5 per cent. may be observed, according to the duration of the dyeing operation.

It may also be generally accepted that the loss in weight experienced in the dyeing of cops is much the same as in the dyeing of hanks. It is notable, however, that some colouring matters tend appreciably to increase the weight of the cotton: these include indigo, the one-bath and oxidation aniline black, logwood black, cutch brown, and turkey-red. Indeed the increase in weight may in some instances reach 7 to 10 per cent. Some interesting experiments on this matter have been recently carried out. American cotton in 24's warp yarn was treated in portions, one bleached and the other dyed several typical colours, weighings being made before and after treatment only after hanging the yarn for a period of 24 hours in a room at a temperature of 30 deg. C. The normal weight of a bundle of the yarn was 4.54 kilos. Upon treating, and again weighing after the prolonged drying, the following results were obtained:—

	Weighed. Kilos.	Shown a loss of
Bleached yarn .....	4.48	1.32 per cent.
Sky-blue indigo yarn .....	4.52	0.44 „
Light-blue indigo yarn ...	4.52	0.44 „
Grey yarn boiled without soda .....	4.53	0.22 „
Medium blue indigo .....	4.53	0.22 „
		Gain.
Dark-blue indigo .....	4.60	1.32 per cent.
Yellow (cotton yellow) ...	4.62	1.76 „
Alizarine pink .....	4.63	1.98 „
Methylene blue .....	4.68	3.08 „
New Victoria green .....	4.68	3.08 „
Slate (diphenyl black) ...	4.69	3.30 „
Dark-blue (indigo topped with logwood) .....	4.75	4.62 „
Black (one-bath aniline black) .....	4.80	5.73 „
Yellow (chrome yellow)...	4.80	5.73 „
Alizarine red .....	5.05	11.23 „
Orange (chrome orange)...	5.25	15.64 „
Dark-brown (catechu) ....	5.26	15.86 „

The small loss accounted for in the case of the bleached yarn may be due to the fact that it was treated

by the centrifugal system. That the sky blue, light blue, and medium blue, with indigo, should also show a loss in weight is due doubtless to the relatively greater alkalinity of the vat-liquor. The great amount of manipulation necessitated with these colours in subsequently washing and souring will also account for the removal of many impurities from the yarn.

## FINISHING

The several processes of finishing have for their object the improvement of the appearance of the cloth—and as often as not its strength—as well as (in other instances) the augmentation of its weight and the modification of its feel to the touch. The imparting of these special characteristics is carried to the extent of giving to certain makes of cotton goods the appearance and semblance of linen, wool, or silk. Finishing is an extensive and complicated art: for, at the outset, the various manners of working secure initial modification according to whether white, grey, coloured, or printed goods are under consideration. Many forms of treatment call for the provision of specially constructed machines; and such considerable progress has been made in this direction in recent years, that not only by their use may cotton goods be given the chief characteristics of silk goods, but even the appearance of embossed paper.

The several main operations that are variously called into use may be classified in the following manner, though order of procedure is necessarily dependent on circumstances:—

Singeing;	Mangling;
Raising;	Moireing;
Shearing;	Embossing
Brushing;	Stentering and
Steaming;	Stretching;
Starching;	Doubling, Measuring,
Impregnating;	and Plaiting;
Breaking-down;	Marking, Pressing,
Damping;	and Packing.
Calendering, various forms;	

Many of the single operations are likewise modified according to the quality of the cloth and the nature of the finish desired. For instance, that of calendering takes many forms—from the comparatively simple process of exerting pressure on the cloth for giving a

slightly smooth surface, to more complicated ones, and to "schreiner" for a very high gloss.

The vagaries of fashion are every season calling for more or less new finishes on special sorts of cloths; but leading main sorts are produced from season to season for certain markets, and some of the more general of these may be briefly passed in review.

In self-coloured and white goods may be mentioned the following qualities:—Calicoes, stripes, quiltings, piqués, moleskins, satins, ticks, twills, muslins, crêpes, orleans, mulls, nainsooks, medium and light medium printed calicoes, dhooties, shirtings, and cretonnes.

These may be divided into two classes:—(1) One including those that remain grey or white, or are to be printed (but all to receive some degree of gloss); and (2) Twilled and figured goods.

Cretonnes are usually given a good coating of starch, and following this come drying, sprinkling, calendering, and doubling and pressing. They are for the most part printed goods. Many very light cottons are, after bleaching, only very slightly starched and lightly calendered. Potato and wheaten starch, along with a little china clay, are used for the purpose. Should a gloss be required on such goods, a very weak starching is given, followed by hot calendering.

Shirtings, on the other hand, require a different form of treatment, because these and many other sorts call for both the appearance and the feel of linen goods. This demand forces the use, besides starch, of wax, tallow, china clay, and soap.

The good qualities are finished on both sides, then dried, damped with hot water containing magnesium and sodium sulphates, allowed to lie for a time in the rolled state, and then mangled or beetled.

The thicker qualities of cloths come in for all forms of treatment, according to the finish desired; for a fairly hard satin finish the material may be impregnated with a starch paste containing potato starch and tallow; then dried, damped, calendered, stentered, and beetled. On the other hand, for a soft satin finish a good course of damping, followed by calendering under high pressure but without friction, suffices.

The "scroop" of silk is imparted to a fairly satisfactory extent by adding to the starch paste common

salt or tartaric acid, borax, or alum; though to attain by suitable calendering the high lustre, Glauber's salts come mostly into use. Fustians and moleskins, after raising and brushing, are finished with gum and dextrine.

These instances clearly show the nature of the varied manners of working called for in finishing, and themselves point to the fact that each operation, when essayed, effects its own special modification of the cloth.

— — —

**Linen Finish to Cotton Cloth.**—For 90 gallons of paste mix—

55 lb. wheat starch,  
 55 „ potato starch,  
 33 „ china clay,  
 5½ „ cocoa-nut oil,  
 3 „ Marseilles soap,  
 30 grms. ultramarine.

Boil the whole together for  $\frac{1}{4}$  hour. After starching, dry by suspending in a drying chamber, stretch, and allow to lie for 12 hours. Mangle a few times under high pressure, until the desired linen effect is in view. Do not beetle the cloth.

**Calender Bowl Grinder.**—By using this machine, bleachers, finishers, and others can true-up their calender bowls on the premises, and thus save the expense and loss of time in sending them to the makers. The machine is provided with sliding carriages and adjustable steps, to take in the necks of the bowls. The surface of the bowl is ground by a revolving wheel mounted on a strong tube. This wheel is traversed by a screw, and is controlled by a reversing arrangement. The length of the traverse is determined by stop-brackets, which are fixed at the required distances apart to suit the length of bowl to be ground. The bowl is brought into position for grinding by two hand-screws, each of

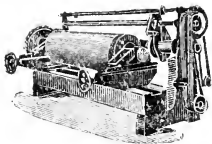

which is fitted with a micrometer dial or collar, graduated to  $\frac{1}{1,000}$ th of an inch. The divisions are numbered to correspond with each other, so that whatever setting takes place it can be done with accuracy.

**Speeds.**—Driving pulley 10 in. dia., 300 revs. per min.



### CLOTH "MELLOWING" MACHINE.

**Function.**—Breaks down or "mellows" over-calendered or over-finished cotton goods.

**Description.**—Consists of a series of scrolls arranged in pairs, and mounted in a cylindrical framing. One scroll of each pair is right-handed, the other left-handed: thus the cloth in passing through the machine is kept central. Half the scrolls are mounted in fixed bearings in the framework; the other half (the outer ones) are mounted in adjustable bearings, and may be made to take up any desired position either in advance of or in the rear of the fixed scrolls. This movement is effected by means of toothed quadrants, which engage with large setting-wheels at each end of the scrolls; the adjustment being made by means of a hand-wheel and worm gear.

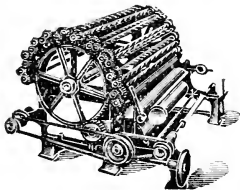

### CLOTH RAISING.

In raising cloth for producing what is known as flannelette there are two types of machines used, namely—those worked on the vertical principle and the cylindrical machine.

The vertical or upright machine is adapted for dealing with hard woven cloth and such other fabrics as require little more than a scratching of the surface.

The cylindrical machine is the most universally adopted, as by its action the nap of the cloth is raised to a degree almost equal in effect to the softest flannels. These machines are made with 12, 24, and 36 rollers, and each roller is covered with a special wire clothing. These rollers have imparted to them a two-fold movement, which with their relation to the axis of the main driving shaft form a sort of "planetary" motion. The rollers, which collectively constitute the cylinder, are divided into two equal sets, arranged alternately over the circumference, and are termed "pile" and "counter-pile" respectively. The pile rollers are covered with card filleting, having its teeth inclined in the direction in which the cloth is coming, whereas those of the counter-pile rollers lean in the opposite direction.

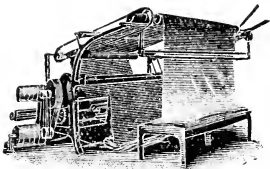

The whole series of rollers are caused to rotate upon their own axes and in the direction opposite to that in which the cloth is moving. The pile rollers raise the nap on the cloth, as do also the counter-pile rollers; moreover, the latter, in addition, impart the required appearance to the cloth. The rollers are mounted in suitable rings, and are caused to rotate round the axis of the main driving shaft; they move in the same direction as the cloth, but at a much quicker surface speed backwards. The cloth as it enters the machine is drawn to the raising cylinder by means of rollers, but before being operated upon it is passed over a steam-heated copper cylinder. The object of the latter is to warm the cloth and prepare it for the raising operation. After raising, the cloth is guided over rollers and plaited-down in the usual manner.

#### Cylindrical Machine.

**Pulley.**—36 in. dia.  $\times$  5½ in. wide.

**Speeds**—

72 in. machine, 85 revs. per min.

80 in. ditto, 80 revs. per min.

85 in. ditto, 75 revs. per min.

A five-speed slip cone is applied to each machine for varying the speed of the cloth as it goes through.

**Floor Space.**—72 in. machine, 12 ft.  $\times$  13 ft. 8 in.; 80 in. ditto, 12 ft. by 14 ft. 4 in.; 92 in. ditto, 12 ft. by 15 ft. 4 in. Height of machine, 7 ft. 7 in.

**Production.**—

24-roller machine—5,000 to 6,000 yards per day.

40- " " —9,000 to 10,000 " "

#### Upright Machine.

**Pulley.**—12 in. dia.  $\times$  4 in. wide.

**Speeds.**—240 revs. per min. **Power.**—3½ I.H.P.

**Floor Space.**—10 ft.  $\times$  7 ft. 4 in.  $\times$  7 ft. 3 in.

**Measuring Cloth.**—A machine is now made which measures the length of a piece of cloth and inserts therein small metal discs at the required distances apart. When measured, the cloth is delivered either in the roll or wound upon blocks. The discs are numbered consecutively, so that at such times as stock-taking, sales, etc., the length of cloth remaining on a roll can be ascertained without the necessity of having to unroll the material by hand. The machine is also fitted with an Indicator, which records the length of fabric run-off, and serves as a check to the discs.

**Comparison of Hydrometer Scales, Twaddle,  
Baume, and Specific Gravity.**

Twaddle.	Baumé.	Specific Gravity.	Twaddle.	Baumé.	Specific Gravity.	Twaddle.	Baumé.	Specific Gravity.
0	0	1.000	52	29.7	1.260	112	51.8	1.560
1	0.7	1.005	54	30.6	1.270	114	52.4	1.570
2	1.4	1.010	56	31.5	1.280	116	53.0	1.580
3	2.1	1.015	58	32.4	1.290	118	53.6	1.590
4	2.7	1.020	60	33.3	1.300	120	54.1	1.600
5	3.4	1.025	62	34.2	1.310	122	54.7	1.610
6	4.1	1.030	64	35.0	1.320	124	55.2	1.620
7	4.7	1.035	66	35.8	1.330	126	55.8	1.630
8	5.4	1.040	68	36.6	1.340	128	56.3	1.640
9	6.0	1.045	70	37.4	1.350	130	56.9	1.650
10	6.7	1.050	72	38.2	1.360	132	57.4	1.660
12	8.0	1.060	74	39.0	1.370	134	57.9	1.670
14	9.4	1.070	76	39.8	1.380	136	58.4	1.680
16	10.6	1.080	78	40.5	1.390	138	58.9	1.690
18	11.9	1.090	80	41.2	1.400	140	59.5	1.700
20	13.0	1.100	82	42.0	1.410	142	59.9	1.710
22	14.2	1.110	84	42.7	1.420	144	60.4	1.720
24	15.4	1.120	86	43.4	1.430	146	60.9	1.730
26	16.5	1.130	88	44.1	1.440	148	61.4	1.740
28	17.7	1.140	90	44.8	1.450	150	61.8	1.750
30	18.8	1.150	92	45.4	1.460	152	62.3	1.760
32	19.8	1.160	94	46.1	1.470	154	62.8	1.770
34	20.9	1.170	96	46.8	1.480	156	63.2	1.780
36	22.0	1.180	98	47.4	1.490	158	63.7	1.790
38	23.0	1.190	100	48.1	1.500	160	64.2	1.800
40	24.0	1.200	102	48.7	1.510	162	64.6	1.810
42	25.0	1.210	104	49.4	1.520	164	65.1	1.820
44	26.0	1.220	106	50.0	1.530	166	65.6	1.830
46	26.9	1.230	108	50.6	1.540	168	67.0	1.840
48	27.9	1.240	110	51.2	1.550	170	67.4	1.850
50	28.8	1.250						

**Comparison of the Thermometer Scales of Celsius or  
Centigrade (C.), Fahrenheit (F.), and Reaumur (Re.).**

DEGREES.			DEGREES.			DEGREES.		
C.	F.	RE.	C.	F.	RE.	C.	F.	RE.
0	32·0	0·0	34	93·2	27·2	68	154·4	54·4
1	33·8	0·8	35	95·0	28·0	69	156·2	55·2
2	35·6	1·6	36	96·8	28·8	70	158·0	56·0
3	37·4	2·4	37	98·6	29·6	71	159·8	56·8
4	39·2	3·2	38	100·4	30·4	72	161·6	57·6
5	41·0	4·0	39	102·2	31·2	73	163·4	58·4
6	42·8	4·8	40	104·0	32·0	74	165·2	59·2
7	44·6	5·6	41	105·8	32·8	75	167·0	60·0
8	46·4	6·4	42	107·6	33·6	76	168·8	60·8
9	48·2	7·2	43	109·4	34·4	77	170·6	61·6
10	50·0	8·0	44	111·2	35·2	78	172·4	62·4
11	51·8	8·8	45	113·0	36·0	79	174·2	63·2
12	53·6	9·6	46	114·8	36·8	80	176·0	64·0
13	55·4	10·4	47	116·6	37·6	81	177·8	64·8
14	57·2	11·2	48	118·4	38·4	82	179·6	65·6
15	59·0	12·0	49	120·2	39·2	83	181·4	66·4
16	60·8	12·8	50	122·0	40·0	84	183·2	67·2
17	62·6	13·6	51	123·8	40·8	85	185·0	68·0
18	64·4	14·4	52	125·6	41·6	86	186·8	68·8
19	66·2	15·2	53	127·4	42·4	87	188·6	69·6
20	68·0	16·0	54	129·2	43·2	88	190·4	70·4
21	69·8	16·8	55	131·0	44·0	89	192·2	71·2
22	71·6	17·6	56	132·8	44·8	90	194·0	72·0
23	73·4	18·4	57	134·6	45·6	91	195·8	72·8
24	75·2	19·2	58	136·4	46·4	92	197·6	73·6
25	77·0	20·0	59	138·2	47·2	93	199·4	74·4
26	78·8	20·8	60	140·0	48·0	94	201·2	75·2
27	80·6	21·6	61	141·8	48·8	95	203·0	76·0
28	82·4	22·4	2	143·6	49·6	96	204·8	76·8
29	84·2	23·2	63	145·4	50·4	97	206·6	77·6
30	86·0	24·0	64	147·2	51·2	98	208·4	78·4
31	87·8	24·8	65	149·0	52·0	99	210·2	79·2
32	89·6	25·6	66	150·8	52·8	100	212·0	80·0
33	91·4	26·4	67	152·6	53·6			

SECTION IX:  
  
WAREHOUSE  
AND  
OFFICE:  
  
COSTING  
  
YARNS AND CLOTH  
  
ETC., ETC.

**FEET AND INCHES WITH NEAREST EQUIVALENTS  
IN METRES.**

Ft. in.	Metres.	Ft. in.	Metres	Ft. in.	Metres.
0 0 $\frac{1}{8}$	0·003	6 0	1·828	29 0	8·838
0 0 $\frac{1}{4}$	0·006	7 0	2·132	30 0	9·143
0 0 $\frac{1}{2}$	0·013	8 0	2·437	31 0	9·447
0 0 $\frac{3}{4}$	0·019	9 0	2·742	32 0	9·752
0 1	0·025	10 0	3·047	33 0	10·057
0 2	0·051	11 0	3·352	34 0	10·362
0 3	0·076	12 0	3·656	35 0	10·667
0 4	0·101	13 0	3·960	36 0	10·972
0 5	0·127	14 0	4·266	37 0	11·276
0 6	0·152	15 0	4·572	38 0	11·581
0 7	0·178	16 0	4·875	39 0	11·886
0 8	0·203	17 0	5·180	40 0	12·191
0 9	0·228	18 0	5·485	41 0	12·495
0 10	0·254	19 0	5·790	42 0	12·800
0 11	0·279	20 0	6·095	43 0	13·105
1 0	0·305	21 0	6·400	44 0	13·410
1 3	0·381	22 0	6·705	45 0	13·715
1 6	0·457	23 0	7·010	46 0	14·019
1 9	0·533	24 0	7·315	47 0	14·324
2 0	0·609	25 0	7·620	48 0	14·629
3 0	0·914	26 0	7·924	49 0	14·934
4 0	1·219	27 0	8·229	50 0	15·239
5 0	1·523	28 0	8·534	100 0	30·478

## GREY CLOTH ANALYSIS

Manufacturers are frequently called upon to weave cloth "to sample" or pattern received from abroad by their agents or merchants. The sample should be carefully dissected, which may be done by the following method:—

**Extracting the Threads.**—A piece of the fabric (say about 32 inches long) should be stretched upon a table to take out the wavy creases, the end to be dissected being nearest the operator. The warp threads are then removed by the aid of a cutting block, 20 inches long by 8 inches wide. This block is laid over the cloth parallel to the selvedge; and the cloth is cut along the edges of the block, retaining the size above stated. A few inches of this is then torn (not cut) from the selvedge, in order to get a straight edge from which to commence operations. The fabric is now laid over the edge of the table, and 36 of the warp threads are withdrawn, care being taken that all the threads removed are the full length of 20 inches.

The warp threads having been extracted, the cloth is turned round; and, by operating in a similar manner, the weft threads are withdrawn. These latter should be taken from a portion of the cloth farthest from the selvedge.

The warp and weft threads will have slightly increased in length on being released from the web of the fabric, so they are now laid out and cut to the exact length of 20 inches.

**Removing Size.**—For practical purposes this may be accomplished by boiling in a weak solution of soda, or steeping in a weak solution of acid, followed by rinsing in clean water and drying. With very heavily sized yarn it may be necessary to repeat the boiling or steeping. When a more exact analysis is required, the following method may be adopted:—

- (1) Boil the twist and weft threads in clear water for 10 minutes. For this purpose a glass beaker may be used.
- (2) Rinse in running water.
- (3) Boil in a 2 per cent. solution of salicylic acid ( $C_7H_6O_3$ ) for 30 minutes.
- (4) Rinse in running water.
- (5) Boil in water 10 minutes.
- (6) Rinse in running water.

Now place the threads between filter paper, and afterwards in a receptacle for weighing—preferably a glass jar or bottle. Put this receptacle, with its contents, into a small drying oven, to which is attached a thermometer. Bring the temperature in the oven gradually up to 212 deg. Fahr. On removing the bottle, sufficient time should be allowed for cooling, after which extract the threads and weigh them on a pair of delicate scales.

The net weight of yarn in its dry state having been thus ascertained, add thereto 7.834 per cent., to bring the yarn up to its correct condition.

## FORMULÆ.

$$\frac{\text{Length in Yards} \times 100}{\text{Weight in Grains after Stripping} \times 12} = \text{Actual Counts.}$$

The threads having been weighed after dissecting, the difference in the weight of the warp or weft gives the percentage of size on the threads. Thus—

$$\frac{\text{Weight of Size in Warp} \times 100}{\text{Weight of Warp before Stripping}} = \text{Percentage of Size in Warp.}$$

*Example—*

21 yards of yarn, taken from cloth, weight	Weft.	Warp.	
in grains .. .. .	.. = 4.13	—	—
20½ ditto ditto ditto	.. = —	4.73	
21 yards of yarn, stripped, dried, added			
normal moisture in grains .. .. .	.. = 4.04	—	
20½ ditto ditto ditto	.. = —	4.34	
	Size in Warp and Weft =	0.09	0.39

$$0.09 + 0.39 = 0.48 \text{ Grains Size on Warp.}$$

$$\frac{\text{Weight of Size} = 0.48 \times 100}{\text{Weight of Yarn before Stripping} = 4.73} = 10.14\% \text{ of Size in Cloth.}$$

$$\frac{\text{Weft .. } 21 \times 100}{4.04 \times 12} = 43.3\text{'s Actual Counts}$$

$$\frac{\text{Warp .. } 20.5 \times 100}{4.34 \times 12} = 39.3\text{'s Actual Counts.}$$



### Slide Rule for Cloth.

**Function.**—A handy instrument for accurately measuring yarn withdrawn from a piece of cloth for costing purposes.

**Description.**—Is an adaptation of the slide rule combined with a square edge. Is formed of two metal measuring plates, which are capable of sliding upon one another. When extended to the utmost limit, the total length of the combined parts is 24 inches; and by sliding the two plates towards each other, the length may be reduced to 21½ inches. At these distances, or at any point between them, the slides may be secured in position by a thumb-screw. Both parts are so formed and fitted together that the ends are always straight and at right angles to the sides.

---

## THE COST OF CLOTH

For the ordinary run of cotton goods woven in the grey state, "cost of cloth" is made up of three chief items, namely—materials, wages, and fixed expenses.

**MATERIALS** comprise—Warp, Weft, and Size.

**WAGES** include those paid—For the Preparation of Yarn, for Weaving, and for "Datal" Operatives (*i.e.*, operatives paid by time, not by piece-work).

**FIXED EXPENSES** include—Rent, Interest, Commission, Depreciation, Rates, Taxes, Insurance, Coal, Gas, Water, Stores, Repairs, Renewals, and Carriage.

For any given fabric the value of materials and also wages paid for Preparation and Weaving can be calculated with reasonable accuracy; but in the majority of cases it is difficult to apportion the remaining items exactly; and it is on this point that the methods adopted by different manufacturers chiefly vary.

To calculate quantities of warp and weft in any given cloth, it is necessary to know the following particulars, all of which must be actual, not nominal:—

1. Total number of ends or warp threads.
2. Warp length, *i.e.*, taper's or slasher's length.
3. Number of picks per inch.

4. Reed width, *i.e.*, width occupied by the yarn in the reed.
5. Cloth length.
6. Yarn counts.

For costing purposes it is necessary that the Quantities should include allowances for "waste"—*i.e.*, material rendered unusable during the various processes. The amount of waste naturally varies with the class and quality of material, the nature of the processes through which it passes, and the style of the cloth. For the ordinary range of cotton cloth, 40 yards per hank (approximately 5 per cent.) will cover the waste made, thus leaving 800 yards per hank actually to enter the cloth. It may be noted that the 40 yards per hank, or 5 per cent., must cover not only the waste actually returned from the various processes, but also loss by damaged pieces, deficiency in counts, and other drawbacks.

The following formulæ are then applied:—

$$\frac{\text{Total Ends} \times \text{Taper's Length}}{800 \times \text{Counts}} = \text{Weight of Warp Yarn, including Waste.}$$

$$\frac{\text{Picks per Inch} \times \text{Reed Width} \times \text{Cloth Length}}{800 \times \text{Counts}} = \text{Weight of Weft Yarn, including Waste.}$$

The cost of Sizing Materials is usually included in the fixed expenses, but sometimes it is treated separately. In the latter case, the total cost of a mixing is divided by the number of pounds of yarn it will size, and is thereby reduced to a price per lb. It may then appear as a separate item in the cost, or be added on to the yarn price.

Wages for Preparation—*i.e.*, winding, warping, sizing, and drawing-in or twisting—and also for Weaving, are invariably based upon piece-work rates, which are contained in various "Lists" agreed upon by employers and operatives. Such charges for any given cloth can therefore be definitely calculated.

As already stated, the remaining items can be dealt with in different ways. Thus the cost per piece, on account of one or all of them, can be obtained by dividing the total number of pieces produced in a given period into the amount expended during the same period; or they may be apportioned to each loom and divided by the number of pieces which it will turn off. The general

method, however, is to compare all the charges with the wages paid for weaving, and reduce them to a percentage thereof. Since the weaving wage for a given cloth can easily be calculated, it is then only necessary to add the required percentage for expenses. When the ranges of fabrics produced by a given concern do not vary considerably, the method is sufficiently accurate for practical purposes. Further, under similar conditions it will be found that the preparation wages—*i.e.*, winding, warping, drawing-in, etc.—vary only in a slight degree; therefore these also may be included in the percentage of expenses.

The items as well as the amounts will, of course, vary for different mills and different classes of cloth, but for the ordinary run of plain goods it is considered that all expenses, other than the weaving wage, amount on an average to 75 per cent. of the latter—or (as it is termed) expenses are three-quarters of the weaving wage. Thus the cost of a cloth would be one-and-three-quarter weavings, in addition to the cost of warp and weft.

As an example, we may take a standard cloth, known on the market as “36-76, 19 × 22, 32/36.” This (stated at length) means that the cloth is 36 inches wide, 76 yards long, and contains 19 “ends” (or warp threads) and 22 “picks” (or weft threads) per quarter inch, while the twist or warp is 32’s and the weft 36’s—all being actual, not nominal, particulars. Certain allowances for contraction in the warp length and shrinkage in the width must be made, the same varying considerably according to the style of cloth, nature of yarns, and other factors. In this case we assume them to be approximately 6 per cent., which will give the Warp or taper’s length to be 76 + 6 per cent. = 80.5 yards, and the Reed width 36 + 6 per cent. = 38.16 inches.

	Ends per inch.	Inches.	Yards.	
Weight of Twist	76	× 36	× 80.5	= 8.6 lb.
	800 × 32			
Weight of Weft	88	× 38.16	× 76	= 8.8 lb.
	800 × 36			

**To find the Weaving Price.**—This is obtained from the “Uniform List of Prices for Weaving,” and may be

worked out as follows (assuming the cloth to be woven on a 41-inch reed space loom):—

2d.	per pick.	
22	= picks per $\frac{1}{4}$ in.	
<hr style="width: 10%; margin-left: 0;"/>		
44	= price per 100 yards.	
2.2	= 5 per cent. deduction for width of loom.	
<hr style="width: 10%; margin-left: 0;"/>		
41.8		
76		
<hr style="width: 10%; margin-left: 0;"/>		
31.76	= price for 76 yards (divided by 100 yards).	
1.58	= 5 per cent. on for reed used.	
<hr style="width: 10%; margin-left: 0;"/>		
33.34		
1.33	= 4 per cent. on for picks.	
<hr style="width: 10%; margin-left: 0;"/>		
34.67	= weaving price.	

We thus ascertain the Total Cost of the Cloth to be—

	d.
Warp: 8.6 lb. at 10d. ....	86
Weft: 8.8 lb. at 9 $\frac{3}{4}$ d. ....	85.8
Weaving wage .....	34.67
Expenses 75 per cent. ....	26.0
<hr style="width: 10%; margin-left: auto;"/>	

Total cost per piece ..... 232.47 = 19/4 $\frac{1}{2}$

For **coloured** and **fancy** goods the method of costing usually adopted is similar to that explained above for grey goods—except that some of the items there included in the general expenses are treated separately, and (as may be expected) the remainder bear a higher ratio to the weaving wage, owing to the more extensive and complicated nature of the preparatory and other processes.

An example is given below to show the method of dealing with the various items, those for Preparation being taken separately, and the remainder as equal to the Weaving Wage. This method is termed "Double Weaving and Preparation." Prices for fancy cloths are generally quoted per yard, and it is generally more convenient to calculate the total cost of the cloth obtained from a full warp, as the preparation costs can be more easily dealt with.

**To find** the cost per yard of the following blouse material:—400 yards cloth from 440 yards warp; reed 34 dents per inch, 32 inches wide in the reed, 17 picks

per  $\frac{1}{4}$  inch, 32's blue and 2/40's white mercerised, checking pattern exactly as warp pattern:—

## WARP PATTERN.

36 blue	40's
4 white mercerised	2/40's
36 blue	40's
4 white mercerised	2/40's
12 blue	40's
10 white mercerised	2/40's
12 blue	40's
4 white mercerised	2/40's

—  
118

18 repeats

—  
944

118

—  
2,124

24 blue added

28 white 2/40's selvedge

—  
2,176

## PRICES.

40's warp, at 1s. 1d. per lb.

2/40's selvedge yarn, 1s. 0 $\frac{1}{2}$ d. per lb.

32's weft yarn, 10d. per lb.

2/40's white mercerised, 2s. 6 $\frac{1}{2}$ d. per lb.Bleaching 2/40's selvedge,  $\frac{3}{4}$ d. per lb.Dyeing blue warp, 3 $\frac{1}{2}$ d. per lb.Dyeing blue weft, 2 $\frac{1}{2}$ d. per lb.

Sizing blue warp and selvedge yarn, 7d. per blue.

Winding 40's and selvedge yarn, 1d. for 30 hanks.

Winding weft and mercerising warp, 1d. for 20 hanks.

Warping, 8d. per 1,000 hanks.

Beaming, 1d. per 100 yards.

Drawing-in, 6d. per 1,000 ends.

Weaving, 3d. per pick per  $\frac{1}{4}$  inch for 100 yards cloth.

Expenses, same as weaving.

Finishing,  $\frac{1}{4}$ d. per yard.

Allow 40 yards per hank for waste in warp and weft.

## SUMMARY.

Ends blue,	96 × 18 + 24 =	1,752
.. white,	22 × 18 =	396
.. selvedge		28

—  
2,176

	Hanks	Counts	Weight	Price	Pence
Blue warp	963'6	40's	24'03	1/1	313'17
	1752 × 440				
	800				
White mercerised warp	217'8	2/40	10'89	2/6½	332'14
	396 × 440				
	800				
Selvedge	15'4	2/40	'77	1/0½	9'63
	28 × 440				
	800				
Blue weft	885'33	32's	27'67	10	276'70
	68 × 32 × 400 × 96 picks per pattern				
	800 × 118				
White weft	202'85	2/40	10'14	2/6½	309'27
	68 × 32 × 400 × 22				
	800 × 118				
Bleaching selvedge yarn	—	—	'77	¾	'58
Dyeing blue warp	—	—	24'00	3½	84'32
Dyeing blue weft	—	—	27'67	2½	69'18
Winding 40's and selvedge	979'00	—	—	1d. per 30	32'62
Winding weft and mercerised warp	1305'98	—	—	1d. per 20	65'30
Warping (2176 × 440) ÷ 840	1139'81	—	—	1d. per 1,000	9'12
Sizing blue warp and selvedge	—	—	24'83	7d. per 101b	17'38
Beaming, 440 yds.	—	—	—	1d. per 100 yds.	4'4
Drawing-in, 2,176 ends	—	—	—	6d. per 1,000	13'06
Weaving, 400 yds., 17 picks, @ 3d. = 17 × 3 × 4	—	—	—	—	204'00
Expenses as weaving	—	—	—	—	204'00
Finishing, 400 yds.	—	—	—	¼	100'00
Total cost	—	—	—	—	2044'87

Price per yard, 2044'87 ÷ 400 = 5'11 — say 5½.

## “ CLOTH-LOOKING ”

### FAULTY CLOTH AND ITS CAUSES.

The chief faults in cloth caused during weaving are :—

**Ends Out.**—Undue breakages caused by (a) faulty yarn, as thick soft places, thin places, snarls, and knots; quality too low for the cloth to be woven; (b) faulty preparation of the warp during warping, sizing, or beaming; (c) undue strain on the yarn during weaving by incorrect setting of the loom parts. Broken threads arising from one or other of the above causes may not be immediately replaced by the weaver, and an unsightly place is the result. Looms can now be provided with various motions for automatically stopping the loom on the breakage of a warp thread.

**Missed Picks or Broken Patterns.**—Are caused by the weaver failing to adjust the tappet, cards, or lags after a breakage of the weft. Broken patterns also result from wrong drafts, pegs falling out of dobby lags, or jacquard hooks not acting.

**Floats.**—Are chiefly caused by broken ends, long knots, or broken heald or harness cords becoming entangled with a number of adjacent ends, thus interfering with their correct weaving.

**Reedy, Bare, or Badly Covered Cloth.**—Is chiefly seen in plain cloth or calico, and is caused by the warp threads running together in pairs instead of being evenly separated. This is due to incorrect setting of the warp rollers and incorrect timing of shedding and picking, also to improper tensioning or pacing of the warp.

**Bad Selvedges.**—Are due to faulty beaming of the warp near the flanges, wrong drafting of the selvedge ends, number of selvedge ends too great or too small, defective temples, and improper tensioning of the weft.

**Uneven Cloth, or Thick and Thin Places.**—Due to uneven delivery of the warp or taking up of the cloth, by derangement of the letting-off or taking-up motions, or to the incorrect adjustment of the latter motion by the weaver after a failure or breakage of the weft.

**Traps or Smashes.**—Are caused by the sley moving towards the cloth with the shuttle trapped in the shed or opening in the warp thread, which results in the breakage of a considerable number of ends.

**Looped Weft.**—Is due to insufficient tension on the weft as it leaves the shuttle, or rebounding of the latter as it enters the box.

**Weft Picking Under.**—Is due to uneven shedding or improper cording of the healds.

**Box Marks.**—Are marks or stains made upon the weft by its being caught between the shuttle and box sides.

**Oil Spots and Stains.**—Are due to the careless use of oil by the weaver or by drippings from the dobbie, jacquard, or shafting.

**Mildew.**—Is a fungoid growth originating from, and subsisting upon, the vegetable and animal substances used in the size mixing. When the latter is properly constituted, it contains substances which will prevent its growth. It makes its appearance upon cloth in furry patches of various colours, chiefly green in England. In the early stages of its development it can be washed from the cloth by ordinary soap and water without leaving any permanent trace; later it leaves a stain or discoloration, but washing with a solution of bleaching powder may remove the marks, otherwise bleaching must be resorted to; and finally it attacks and rots the yarns.

**Iron-mould Stains.**—Are detected by their rusty appearance. They occur in pieces that have been standing in the loom over the week-end. The decreased temperature of the weaving shed at this period often causes moisture to be deposited on the ironwork of the loom with which the cloth has been left in contact. If caused by contact with the reed, the marks are streaky, if from the breast beam of the loom they show across the cloth.

It is a common practice for weavers to remove oil and iron stains by washing with a weak solution of oxalic acid. The parts so treated are apt to show in patches and sometimes cause the cloth to contract in width. If, however, the acid be thoroughly washed out, no serious injury is done to the cloth.

### CLOTH-CUTTING MACHINE.

**Function.**—To cut cloth into small pieces for use as pattern samples by merchants, agents, and others.

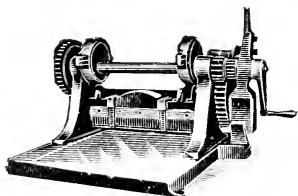

**Description.**—The machine is provided with a knife, which by means of a hand-lever is caused to travel from its top position through several thicknesses of the fabric. The course of the knife is guided between slots cut in discs fixed at the sides of the machine. The machines are



made in various sizes; they can be worked either by hand or power, and will take in cloth up to 32 inches wide and in layers up to  $1\frac{1}{2}$  inches thick.

## THE OFFICE

**INVOICING.**—An invoice for cloth should give the following particulars:—

- Length of each piece.
- Width of each        ,,
- Reed and pick per inch or quarter inch.
- Counts of warp and weft threads.
- Weight per piece.

**Length.**—Goods may be bought to either “long or short stick.” The former implies  $36\frac{1}{2}$  inches to the yard, while the latter means precisely 36 inches. The length may be roughly ascertained by counting the folds made by the plaiting machine.

**Width.**—The terms “Actual” and “Nominal” are used in the trade to indicate (1) that the width should be taken as stated, or (2) that a certain amount of allowance should be made. “Actual” implies that the width is not less than stated. “Nominal” means that the width of the cloth may vary as much as half-an-inch below width given on contract.

**Reed and Pick.**—It is best to use counters giving the number of picks per inch, as the fraction of a pick is more readily detected than when quarter-inch counters are used. The terms “Actual” and “Nominal” are also used here with practically the same meaning as in the case of the width of the cloth. Under “Nominal” conditions the number of picks may be 2, 3, or 4 below the stated number. Thus a cloth described as  $19 \times 22$  “full or actual” should contain 76 ends and 88 picks per inch, but if described as nominal it may have 74, 73, or 72 ends per inch and 86, 85, or 84 picks per inch. If  $74 \times 86$  it would be termed “2 down,” if  $73 \times 85$  “3 down,” and so on.

**Counts of Warp and Weft.**—“Nominal” and “Actual” are terms likewise used here, and for similar reasons. They must be taken into account when comparing one piece of cloth with another, or in making a complete analysis of the fabric. If the goods are intended for

bleaching or dyeing, it is not so important to make this investigation as when they are destined for shipment in the grey state.

### RAILWAY RATES (BRITISH AND IRISH) ON TEXTILES.

Manufacturers often wonder how it is that railway charges frequently vary for similar classes of goods. If careful attention be given to the matter, considerable saving can be effected with respect to railway carriage charges, for traders are not infrequently overcharged through the ignorance or the carelessness of the railway companies' clerks, and—owing to their own ignorance—they pay the overcharges. An enormous sum is paid for carriage every year in the United Kingdom—approximately £35,000,000—of which not improbably £100,000 or more represents overcharges alone; indeed this figure must be rather under the mark than over.

To explain where and how the overcharges are most often made, a short list of some of the articles used and manufactured in the cotton trade is given below, along with an explanation including the names of the various rates under which such goods are classified:—

	Class.
Cotton, raw, in press-packed bales .....	1
Cotton, other than as above .....	2
Cotton waste, not oily, for paper making, hydraulic or steam-press packed .....	C
Cotton, not oily and not for paper making .....	1
Cotton "wool," dressed or carded .....	3
Cotton and Linen Goods, in bales, boxes, cases, hampers, packs, or trusses .....	3
Cotton, light drapery .....	4
Calicoes .....	3

It will be noticed that the articles come under various classes, and therefore different rates. For convenience and classification purposes all goods are divided into sections or classes; and the items mentioned above are represented in five different classes, of which Class "C" is the lowest.

Class "C" is lower than Class 1, and is not a carted or station-to-station rate.

Class "1" is lower than Class 2, and is a carted-and-delivered rate.

Class "2" is lower than Class 3, and is a carted-and-delivered rate.

Class "3" is lower than Class 4, and is a carted-and-delivered rate.

Class "4" is the highest rate here represented, and is also a carted-and-delivered rate.

The Class "C" rate includes the charge for hire for use of companies' wagons, loading and unloading, covering and uncovering, station terminals for use of stations. The rates for conveyance in Classes 1 to 4 include the charges for loading and unloading, covering and uncovering, hire for use of companies' wagons, station terminals for use of stations, the rate for conveyance and the charge for cartage (at both the receiving and the forwarding end) unless specially notified to the contrary in the railway companies' Rate Book.

Should the trader perform any of the services which are shown above as being included in the rate, he should claim an allowance for such performance. No rebate or allowance is allowed unless claimed by the trader. By neglecting to apply, the trader often loses a considerable amount, especially on goods carried at a carted rate, which sometimes the trader carts himself.

To show the difference between the Class rates, an example is given below:—

<i>Class C.</i>	<i>Class 1.</i>	<i>Class 2.</i>	<i>Class 3.</i>	<i>Class 4.</i>
19s. 8d.	31s. 8d.	39s. 4d.	45s. 6d.	55s. 10d.

Exceptional rate for Cotton and Linen Goods for Export,  
32s. 6d.

It is in the application of the Classes that most overcharges are made. It frequently happens that goods under Class 2 are charged at Class 3, while articles in Class 3 are charged at Class 4. As a case in point, take cotton and woollen goods, Class 3, which are sometimes charged at Class 4 (the same as light drapery). Such cases occur every day—and it is not to be wondered at, considering how inexperienced are some of the young men who are employed on the railways as forwarding clerks.

Exceptional rates are often in operation between many stations for textile goods, and the manufacturer, instead

of being charged at the exceptional rate (which is generally lower than the ordinary Class rate) is asked to pay at the higher rate. The reason for this is that sometimes the railway clerk overlooks the special rate.

Another case in which the trader is overcharged is in connection with small consignments of three cwt. or under. It is not generally known that a railway company may charge a sum which often equals 1s. 3d. per package in addition to the rate; but so it is. For instance, 1 cwt. at 200s. per ton would not be 10s., but would be 11s. 3d. For calculating these small consignments there is what is termed a "small scale," which may be obtained (free) from any railway office. Where the public is overcharged in the small consignments is when there are two or more consignments on one day, from the same senders, to the same consignee. The correct way to charge is—

	cwt.	qrs.	lb.	s.	d.	s.	d.
1 Bale Calies .....	1	2	0	at 45	6	...	—
1 Bale Woollen Goods .....	1	2	0	at 43	4	...	—
	<hr/>			3	0	0	at 45 6 ... 7 6

Not, as is frequently charged, thus:—

	cwt.	qrs.	lb.	s.	d.	s.	d.
1 Bale Calies .....	1	2	0	at 45	6	...	4 1
1 Bale Woollen Goods .....	1	2	0	at 43	4	...	3 11
	<hr/>			3	0	0	8 0

The regulation relating to the above is often neglected by the companies' officials, and it is given below for reference:—

"When a consignment of two or more packages (not exceeding 3 cwt.) is comprised of merchandise in two or more Classes, the weight in each Class is charged as a separate consignment, unless the charge of the total weight at the highest of such Classes be less.

"When a consignment of two or more packages (not exceeding 3 cwt.) from the same consignor to same consignee is comprised of merchandise in one Class of the specification, the whole is charged as one consignment.

The principal points have been given wherein textile manufacturers are overcharged; and if due care be used in consigning the goods and checking the railway accounts, some beneficial result should accrue therefrom.

## COTTON SPINNING, WEAVING, &amp;c.

## British Patents:

Complete Specifications Accepted, Nov. 1st, 1908, to  
Oct. 30th, 1909.

1906	1907	1907	1908
26,462 Pierce & Aspin—Picker buffers of looms		27,220 Longmore & Leslie—Unwinding yarns	
		25,239 Wortley—Machines for twisting yarns	
23,050 Houget—Ring frame spindles			
18,070 Beaumont & Hollis—Shedding devices of looms			
21,454 Eckersley—Carding engine locking motion		753 Wilson Bros. Bobbin Co.—Shuttles for looms	
23,827 Buckley—Carding engine locking motion		1,037 Buckley & Another—Condenser carding engines	
25,827 Carver—Stop-motion for looms		6,334 Noah—Spindles of spinning machines	
23,902 Sulzbach—Dyeing machine		6,446 Lehman—Grinding card machines	
28,583 Robertson—Flyers for spinning and doubling		8,037 Hedrich—Manufacture of chenille	
28,186 Fitchett & Another—Scouring, dyeing, etc., machines		11,484 Marsden & Ogden—Ring frames	
25,676 Newton—Twist lace machines		11,680 Taylor—Loom shuttles	
25,976 Higginson & Arundel—Winding machines		13,224 Hamer—Doffing motion for ring frames	
26,564 Ashworth & Another—Spindle footsteps		13,933 British Cotton & Wool Dyers' Assn. & Another—Cop dyeing machines	
26,703 Westcott & Potter—Sliver machines		15,420 Northrop Loom Co.—Thread cutting temples	
26,917 Rankin & Another—Braiding machines		1,441 Redfern—Winding bobbins of lace machines	
27,181 Norddeutsche & Another—Removing combed bunches from combing machines		2,169 Humphries—Looms for tufted pile fabrics	
27,587 Clegg—Take-up motion for looms		3,823 Cole—Weaving Axminster or moquette carpets	
27,595 Reynolds—Thread Guide Rods of doubling machines		3,917 Crompton & Knowles Loom Works—Weft filling looms	
27,729 Stott—Humidification of cotton mills, etc.		7,074 Whitehead & Another—Fabric-breaking machines	
27,807 Bodemer—Driving drums of mules and ring frames		8,617 Chambers—Roller temples for looms	
28,025 Palmer—Thread guides for ring frames		11,308 Bergmann—Ring frames	
28,174 Wrights—Doffing motion for flyer frames		15,034 Ryerson—Producing ornamental fabrics	
28,251 Peters—Driving cylinders for spinning frames		15,364 Bovensiepen—Cleaning carding flats	
28,603 Kruger—Jacquard card-punching machines		15,400 Humphries—Carpet & other looms	
28,758 Delahousse—Beat-up devices of looms		17,361 Alberts—Covering the holes in cards	
27,066 Scott—Degreasing yarns, fabrics, etc.		4,250 Jardine & Another—Mechanism of lace machines	

## Complete Specifications Accepted.—Continued.

## 1908

- 6,784 Hertzog—Pile-cutting for velveteen  
 7,068 Dickinson & Another—Drop box motions of looms  
 7,771 Knowles—Coiling motions for sliver cans  
 9,468 Spinnerei und Weberei Steinen Akt.-Ges.—Weft filling looms  
 11,676 Wilson—Bearings for flyer spindles  
 16,938 Brugger—Loom shuttles  
 17,094 Union-Bank & Rauch—Weft filling looms  
 2,468 Ducketts—Yarn spindles  
 4,968 Mitchell—Winding machines  
 6,711 Wadsworth & Another—Jacquards  
 7,095 Vauthier—Dressing weavers' shuttles  
 14,744 Noack—Jacquards for looms  
 68 Kundig-Honegger—Dust removers for carding engines  
 1,045 Klein—Automatic looms  
 4,930 Wachtler—Automatic looms  
 5,408 Hansen—Thread-winding machines  
 15,947 Eilhauer—Loom sley motion  
 1,389 Mitchell—Lace-dressing frames  
 3,431 Morton—Manufacturing chenille fabrics  
 16,334 Beaumont & Hollis—Shedding of looms  
 2,179 Jackson & Another—Slubbing, etc., frames  
 5,152 Hocknell & Barlow—Heald shafts  
 12,783 Ahorn—Manufacture of chenille  
 13,612 White—Fancy covers for cards  
 14,182 Schopper—Counting threads in fabrics  
 17,183 Higham—Threading loom shuttles  
 4,407 Driver—Automatic stop-motion for mules  
 366 Mills—Burners for singeing  
 2,266 Beattie & Another—Thread holder and cutter for reels  
 2,756 Spridgen—Dropper sley boxes for jacquards  
 5,915 Bragg—"Fancy" rollers of cards  
 6,616 Walker & Haworth—Loom dobbies

## 1908

- 7,067 Rouse—Cop spinning and twisting frames  
 15,588 Lumpp & Leuze—Looms  
 17,184 Barlows—Looms for weaving bags  
 2,446 Gibson & McKinstry—Reeling machines  
 3,524 Crompton & Knowles Loom Works—Worm driving for looms  
 4,011 Thornton & Others—Plates for pressing fabrics  
 5,076 Boyds—Spinning & twisting frames  
 5,238 Warsop—Bobbins for lace machines  
 6,617 Whalleys—Loom pickers  
 7,555 Whitlow & Heap—Preparing and spinning frame top rollers  
 8,915 Strang—Loom shuttles  
 10,659 Sutcliffe—Sliver cans  
 17,064 Lemarchands & Another—Loom shuttles  
 20,874 Cooper—Carrying spools for weaving tufted fabrics  
 444 Bailey—Machines for scouring textile fabrics  
 1,287 Abbott—Drawing rollers of cotton machinery  
 5,711 Cook & Leigh—Weft feeler for looms  
 7,361 Crompton & Knowles Loom Works—Dobbies for looms  
 7,761 Northrop Loom Co.—Filling mechanism for looms  
 8,615 Allen—Loom pickers  
 15,467 Schweinem & Another—Thread guides  
 18,578 Marschik—Wage registering apparatus for looms  
 481 Wardwell—Winding machines  
 4,755 Staubli—Double-lift dobbies  
 8,354 Ward & Eastwood—Guard for slubbing, etc., frames  
 9,113 English—Tension device for winding frames  
 11,955 Nuver—Loom shuttles  
 13,344 Canepa—Circular looms  
 15,014 Dinglinger—Spindles for spinning frames  
 18,156 Nelson—Loom shuttle  
 1,293 Hollas & Another—Beating-up motion for looms  
 4,989 White—Plaiting machines for cloth

## Complete Specifications Accepted.—Continued.

1908

- 7,132 Koechlin—Ring-twisting machines  
 7,363 Crompton, Etc.—Multiplier for looms  
 7,662 Bentley—Cloth pressing  
 9,285 Wintermayr and Another—Power-looms  
 25,607 Whyte & Another—Picking motion in looms  
 1,875 Entwisle—Automatic looms  
 2,056 Grosvenors and Another—Weaving tufted fabrics  
 2,363 Smith—Mechanism for looms  
 5,361 Hargreaves—Locking covers of carding engines  
 6,010 Pilling—Carding engines  
 7,769 Crompton, Etc.—Shuttles for automatic looms  
 8,349 Forrest—Guard for calendering machines  
 8,616 Black—Pressing rollers of spinning, etc., machines  
 17,684 Toyoda—Heddles for looms  
 20,470 Sultzzer—Threading loom shuttles  
 7,619 Krall—Cotton opening, etc., machines  
 9,717 Northrop Loom Co.—Filling mechanism for looms  
 11,365 Heyworth & Another—Spinning frames  
 12,307 Hansen—Jacquards for looms  
 21,753 Daudelin—Self-threading shuttles  
 9,245 Bles—Preparing machines for yarns  
 21,426 Eastwood—Stop-motions for winding machines  
 25,076 Irvin and Baldwin—Loom shuttles  
 3,936 Fine Cotton Spinners' Asso.—Mules  
 5,347 Cook & Potter—Warp stop-motions for looms  
 7,158 Hope—Ring spinning and doubling frames  
 9,715 Northrop Loom Co.—Filling mechanism for looms  
 9,718 Parkinson—Carding engines  
 16,612 Friesendorp & Another—Stop motion for ring spinning frames  
 19,774 Abell—Picking-motion of looms  
 21,042 Taylor—Traverse motion

1908

- 1,283 Grosvenor & Another—Carpet looms  
 4,331 Constantines & Another—Spinning frames  
 8,333 Oulton & Jowett—Loom dob-bies  
 9,244 Toone—Jacquard card-punching apparatus  
 9,709 Northrop Loom Co.—Loom mechanism  
 16,347 Poulenc—Driving spinning machinery  
 17,851 Priestley—Carding apparatus  
 18,778 Prest—Loom Temples  
 20,070 Ashworths—Lubricating picker loom spindles  
 28,142 Erben—Examining yarn  
 4,779 Platt Bros. & Another—Ring-spinning doubling frames  
 4,992 Charlesworth—Drying textile fabrics  
 5,041 Wismer—Yarn-reeling machines  
 5,151 Jackson—Tin driving drums for spinning, etc.  
 7,058 Hallows—Measuring motion for looms  
 8,090 Gaunt—Stop motions for spinning machines  
 28,049 Dearden & Green—Woven fabrics  
 480 Wardwell—Winding machines for yarns, etc.  
 4,905 Faulkner—Automatic looms  
 5,070 Wrights—Doffing motion for flyer frames  
 5,157 Burrow & Hampson—Loom shuttles  
 5,455 Barnes—Feeding scutchers, carding engines, etc.  
 9,344 Fine Cotton Spinners' Asso.—Mules  
 9,716 British Northrop Loom Co.—Self-threading shuttles  
 12,110 Hollingworth—Dobbies of looms  
 14,279 King—Loom motion for leno fabrics  
 21,993 Weber—Weft feelers for looms  
 25,086 Fish & Hodgkinson—Mechanism for looms  
 27,949 Draper—Loom shuttles  
 5,765 Wardwell—Yarn-winding machines  
 5,766 & 5,767 Wardwell—Tension device for winding machines

Complete Specifications Accepted.—*Continued.*

## 1908

- 5,832 Schilde—Moistening yarns  
 6,981 Hamer—Let-off motion for looms  
 7,550 Meters, Ltd., & Orme—Measuring motion for looms  
 8,054 Ratcliffe—Moistening cotton  
 9,526 Clegg & Mellor—Grinding flats of carding engines  
 11,227 Applebys—Weft forks for weaving  
 13,835 C. E. Werner—Looms for weaving fringe  
 18,926 Frost—Cloth-plaiting machines  
 22,906 Kuttruff—Picking motions for looms  
 3,759 Wadsworth and Another—Hand-loom  
 7,063 White & Carrs—Looms for pile fabrics  
 8,045 Briggs—Spinning, etc., frames  
 11,186 Golland—Yarn-winding machines  
 12,129 T. Mason—Relieving swell of looms  
 13,258 Art & Another—Spool-changing in looms  
 17,625 Boyd—Ring-spinning machines  
 7,253 Haslam—Stop motion  
 15,128 Dustoor & Another—Cotton gins  
 17,368 Alexander & Another—Waste collector for spinning machines  
 19,159 Rothe—Tearing machines for fabrics  
 21,715 Casperson—Cloth measuring machines  
 162 Woodward & Another—Carpet looms  
 7,443 Lord & Lawrence—Mules  
 7,612 Brown, Boverie—Ring-spinning frames  
 7,821 Belanger—Ring-spinning  
 7,956 Brooks & Doxey & Another—Hopper feeders  
 10,355 Astley—Loom shuttle checking  
 11,397 Burmeister—Bearings of spinning spindles  
 12,973 Bukalov—Thread-twisting machines  
 17,630 Witham & Another—Yarn cleaner

## 1908

- 21,238 Fine Cotton Spinners' Asso.—Mules  
 24,155 Harris—Looms  
 25,085 White—Weft forks of looms  
 8,835 Brintons & Another—Yarn carriers for pile looms  
 10,909 Clegg & Mellor—Tension motion for cone straps  
 12,301 Wood—Looms for weaving carpets  
 13,152 Pierpoint—Loom pickers  
 9,071 Bodemer—Driving drums of cotton machines  
 9,592 Eves—Spinning or twisting frames  
 9,608 Smith & Perks—Picking motion for hand looms  
 9,704 Hacking & Another—Traverse motions of winding machines  
 12,366 Northrop Loom Co.—Warp stop motions for looms  
 17,922 Marshall & Hirst—Buffer loom pickers  
 19,103 Jelly & Willis—Combing machines  
 26,216 Ross & Laird—Jacquards  
 10,143 Sagar—Looms for weaving belts  
 11,226 Applebys—Thread guides  
 13,437 Wary-Thamiry—Spindle apparatus  
 16,403 Lee—Looms for weaving "terry" fabrics  
 3,202 Boyd & Another—Tension device for driving bands  
 10,653 Sampson & Another—Mounting click-motion wheels in mules  
 11,207 Gregson—Dust removers from carding engines  
 13,760 Klug—Apparatus for drying textiles, etc.  
 15,165 Weatherhead—Spinning  
 27,772 Zakorukin—Apparatus for jacquard machines  
 13,147 McCormick—Shedding motion of looms  
 13,301 Keighley & Another—Stop-motion for pile-cutting machines  
 17,906 Northrop Loom Co.—Weft mechanism of looms  
 18,203 Northrop Loom Co.—Weft-feeler for looms



Complete Specifications Accepted.—*Continued.*

1908

1908

- |        |   |        |   |
|--------|---|--------|---|
| 22,232 | Fessmann & Another—Warp-<br>ing machine                             | 14,888 | Cartwright—Jacquards for<br>looms                                 |
| 23,841 | Roschers—Horsehair looms  | 15,251 | Royle & Others—Shuttle-<br>boxes of looms                         |
| 11,386 | Toyoda—Automatic looms  | 16,596 | Sugden—Shuttle-check mo-<br>tion for looms                        |
| 11,594 | Schofield—Removing dust<br>from cards                               | 17,339 | Ishii—Yarn winding reels  |
| 11,855 | Doremus—Cotton gins   | 21,994 | Weber—Jacquard looms  |
| 12,441 | Harrington—Spinning ma-<br>chinery                                  | 22,935 | Pickford—Carding engines  |
| 13,562 | Denison and Another—Oiling<br>piece-goods                           | 15,499 | W. McGee & Another—Ma-<br>chines for balling yarn                 |
| 16,427 | Hock and Another—Weaving<br>chenille                                | 14,563 | Hoyle & Barker—Condensers<br>and drafting                         |
| 17,381 | Cosserat—Weft-filling and<br>stop-motions for looms                 | 15,378 | Schmitt—Spindles for loom<br>shuttles                             |
| 17,790 | Bradbury—Roller for cotton<br>gins                                  | 18,116 | Higginson & Another—Yarn<br>winding machines                      |
| 17,986 | Hargreaves—Removing dust<br>from carding engines                    | 21,971 | Lonsdale—Checking shuttles<br>and pickers                         |
| 22,773 | Pollock & Another—Stop-mo-<br>tions for looms                       | 22,494 | Simm—Carding engines  |
| 28,289 | Regal & Another—Weaving<br>without pattern cards                    | 24,941 | Wismer—Yarn reels   |
| 13,286 | Barbieri—Smash preventers<br>for looms                              | 12,463 | Keith & Another—Yarn-dry-<br>ing machines                         |
| 13,598 | Whitehead—Driving bands,<br>etc., for spinning machinery            | 15,051 | Evenden & Another—Tenter-<br>ing-clips                            |
| 16,061 | Crompton, Etc.—Weave for<br>pile fabrics                            | 16,144 | Greeves & Another—Electric<br>driving of spinning frames,<br>etc. |
| 22,349 | Brown, Boverie—Ring spin-<br>ning frames                            | 17,466 | Stubbs—Hoods for gassing<br>frames                                |
| 24,611 | Wardwell—Cop-winding ma-<br>chines                                  | 18,137 | Place—Levelling healds in<br>looms                                |
| 24,868 | Reeks—Reels for cotton, etc.  | 18,638 | C. H. Pugh, Ltd., & Bull-<br>Spindles                             |
| 13,008 | Lebe—Carding engines  | 20,910 | Higginson & Another—Gass-<br>ing machines for yarn                |
| 13,307 | Pecks—Change motions for<br>looms                                   | 21,851 | Giov. Blumer—Shuttle-chang-<br>ing mechanism                      |
| 17,185 | Ashworth—Carding engines  | 22,047 | Poole—Woven driving belts   |
| 18,601 | Binns—Shuttle-changing me-<br>chanism                               | 22,176 | Weber—Weft-catching and<br>cutting mechanism for looms            |
| 23,102 | Bradley—Loom weft forks &<br>holders                                | 22,334 | Groom—Cylinders for driving<br>spinning, etc., spindles           |
| 13,553 | Stott—Humidifying air   | 15,236 | Wareing—Emery card-grind-<br>ing filleting                        |
| 15,114 | McDade—Measuring & mark-<br>ing fabrics                             | 16,689 | Tomlinson-Haas & Another—<br>Drying textiles                      |
| 25,502 | Orr—Spindles, etc., for spin-<br>ning                               | 19,003 | Cook—Setting top and bottom<br>rollers of cotton machines         |
| 26,608 | Byrnes & Gaylord—Spinning<br>spindles                               | 23,721 | Turlur—Drying yarns   |
| 26,992 | Rushton—Carding engines   | 26,219 | Holt & Others—Woven fig-<br>ured satin cloth                      |
| 14,211 | Hattersley and Another—<br>Shuttle mechanism for<br>smallware looms | 15,337 | Pal—Supplying air to textile<br>mills                             |
| 14,214 | Williamson and Another—<br>Change-box motions of looms              | 15,909 | David—Tension device for<br>warps in looms                        |

## Complete Specifications Accepted.—Continued.

## 1908

- 16,106 Schills—Weaving double-face fabrics  
 18,426 Kuttruff & Another—Dobbies for looms  
 26,516 Lister—Shuttle-guards  
 16,700 Tattersall—Woven fabrics  
 16,760 Richards—Measuring fabrics  
 22,583 Hulme—Carding engines  
 22,917 Gin—Apparatus for singeing threads  
 26,544 Johnson & Another—Shuttle-guards for looms  
 28,146—Salzmann—Rings for ring spinning machines  
 28,552 Fischer—Thread-pulling machine for fabrics  
 17,521 Hiller—Machine for leasing warps  
 23,762 Wilkinson & Another—Measuring motions of looms  
 15,801 Tattersall—Removing dust from cards  
 20,361 Morton—Conveying apparatus for mills  
 21,769 Pickles—Letting-back cloth in looms  
 21,781 Hodgsons—Picking mechanism of looms  
 21,882 Beaumont & Another—Shedding devices of looms  
 21,982 Crompton, Etc.—Filling magazines of weft-filling looms  
 16,439 Schneider—Ring spinning machines  
 21,529 Pilling & Another—Dobbies for looms  
 21,773 Heatley & Field—Shedding motions of looms  
 24,869 Boyds—Spinning & twisting frames  
 25,152 Moorhouse—Pattern chains of looms  
 19,575 Wadia—Carding engines  
 23,649 Hill—Circular box motion for looms  
 20,328 Twist—Pattern mechanism for looms  
 22,553 Puig y Marco—Damping warp threads  
 26,037 Dewhirst & Barlow—Warp beams  
 26 335 Jones—Loom shuttles  
 20,323 Hacking—Cloth plaiting machines  
 20,521 Smith—Loom  
 20,622 Rutnagar—Carding engines

## 1908

- 21,300 G. Hodgson & Others—Loom dobbies  
 21,986 Beaumont & Another—Double looms for weaving  
 24,883 Entwistle—Weft-cutting devices for looms  
 25,890 Tomlinsons and Another—Cloth-raising machines  
 22,988 Crompton, etc.—Weft-filling mechanism for looms  
 23,883 Briercliffe—Machine for testing yarns  
 25,064 Ashworth—Carding engines  
 21,158 Ovenstone & Others—Bobbins for spinning, etc., frames  
 21,987 Beaumont & Hollis—Dobby looms  
 23,628 Ashworth—Carding engines  
 23,863 Bradley—Carding engines  
 24,498 O'Connor & Others—Cloth plaiting machines  
 25,351 Bent & Whiteley—Doubling frames  
 26,220 Hutchinson & Others—Cotton cords  
 22,171 Collins—Cotton cords  
 22,214 Cell Drier Machine Co.—Drying fabrics  
 22,389 Smith Bros. and Another—Drop-box looms  
 22,580 Dowding—Bolsters for ring spindles  
 26,774 Simpson—Looms for pile fabrics

## 1909

- 3,082 & 3,083 Wardwell—Yarn-winding machines  
 934 Fine Spinners and Doublers' Asso.—Mules  
 4,360 Hathaway & Lanning—Warp drawing-in machines  
 1,380 Blair & Others—Looms for leno fabrics  
 1,687 Kershaw & Others—Shuttle-guard for looms  
 4,522 Nelson—Loom shuttles  
 4,341 Art and Maresch—Shuttle-boxes of looms  
 3,286 Brett & Pickering—Shuttle pegs  
 7,394 Wilson Bros. & Another—Shuttles for looms  
 9,021 Do. do.  
 4,575 MacColls—Clearers for spinning frames

Complete Specifications Accepted.—*Continued.*

## 1909

- 4,916 T. Taylor & Another—Manu-  
 facture of warp pile fabrics  
 10,269 Siemens Schuckertwerke Ges.  
 —Driving looms  
 14,320 Chernack—Circular looms  
 4,739 Frasers—Flyers for spinning,  
 etc., machines  
 5,518 Leaver—Warp-dressing frames  
 16,168 Morganti—Stop-motions for  
 fly-frames  
 1,410 Fehr & Kaufmann—Heddles  
 2,710 Ott—Reed motions of looms  
 3,253 Hocknell & Another—Shafts  
 for wire healds  
 5,809 Klutgens & Another—Loom  
 temples, etc.  
 3,783 Walker—Stripping “waste”  
 off bobbins or pirns  
 5,354 Lefevre—Mules  
 2,577 Hall & Kay—Dust removing  
 4,806 Paechtner—Drawing mechan-  
 ism for spinning frames  
 4,894 White—Fancy covers for  
 carding engines  
 11,808 Schmidt—Spools  
 13,822 Brierleys—Spindle grip for  
 shuttles  
 15,707 Mills—Burners for singeing  
 9,995 Zaiser—Making knots in  
 winding, etc.  
 10,185 Sheard—Pickers for looms  
 1,348 Beluze & Another—Weft-re-  
 plenishing for looms  
 5,689 Millecam—Flyer spinning  
 machinery

## 1909

- 12,160 Toyoda—Loom picking mech-  
 anism  
 5,135 Newsholme—“Doffers” for  
 spinning frames  
 7,943 Muller—Guiding fabric  
 10,780 Soc. Alsacienne—Combing  
 machines  
 15,226 Carbonell—Jacquard card  
 machines  
 20,377 Hunt & Riley—Loom shuttle  
 checks  
 7,392 Schmidt—Mules  
 470 Soc. Meyer & Perrin—Draw-  
 ing apparatus for spinning  
 frames  
 4,440 Graf—Picking motions for  
 looms  
 41 Forrest—Carding engine  
 43 W. McGee & Another—Yarn-  
 winding apparatus  
 6,116 Fine Spinners’ Asso. & An-  
 other—Lags of lattice con-  
 veyors  
 7,912 Kratky—Looms for loop fab-  
 rics  
 9,471 Scott—Jacquard connections  
 14,320 Chernack—Circular looms  
 887 Willot—Multiple woven fab-  
 rics  
 9,374 Dudley—Loom shuttles  
 11,092 Union Bank & Bim—Weft-  
 change mechanism for looms  
 11,802 Keith & Another—Separating  
 threads  
 13,794 Harrop & Another—Sliver  
 lap machines

## Cotton Cloth Factories Act, 1889.

Maximum Limits of Humidity of the Atmosphere at given Temperatures.

Dry Bulb Readings.	Wet Bulb Readings.	Grains of Moisture per cubic foot of Air.	Percentage of Humidity Saturation = 100	Dry Bulb Readings.	Wet Bulb Readings.	Grains of Moisture per cubic foot of Air.	Percentage of Humidity Saturation = 100
35°	33°	1.9	80	68°	66°	6.6	88
36	34	2.0	82	69	67	6.9	88
37	35	2.1	83	70	68	7.1	88
38	36	2.2	83	71	68.5	7.1	85.5
39	37	2.3	84	72	69	7.1	84
40	38	2.4	84	73	70	7.4	84
41	39	2.5	84	74	70.5	7.4	81.5
42	40	2.6	85	75	71.5	7.65	81.5
43	41	2.7	84	76	72	7.7	79
44	42	2.8	84	77	73	8.0	79
45	43	2.9	85	78	73.5	8.0	77
46	44	3.1	86	79	74.5	8.25	77.5
47	45	3.2	86	80	75.5	8.55	77.5
48	46	3.3	86	81	76	8.6	76
49	47	3.4	86	82	76.5	8.65	74
50	48	3.5	86	83	77.5	8.85	74
51	49	3.6	86	84	78	8.9	72
52	50	3.8	86	85	79	9.2	72
53	51	3.9	86	86	80	9.5	72
54	52	4.1	86	87	80.5	9.55	71
55	53	4.2	87	88	81.5	9.9	71
56	54	4.4	87	89	82.5	10.25	71
57	55	4.5	87	90	83	10.3	69
58	56	4.7	87	91	83.5	10.35	68
59	57	4.9	88	92	84.5	10.7	68
60	58	5.1	88	93	85.5	11.0	68
61	59	5.2	88	94	86	11.1	66
62	60	5.4	88	95	87	11.5	66
63	61	5.6	88	96	88	11.8	66
64	62	5.8	88	97	88.5	11.9	65.5
65	63	6.0	88	98	89	12.0	64
66	64	6.2	88	99	90	12.3	64
67	65	6.4	88	100	91	12.7	64

SECTION X:

VENTILATION, ETC.

MOTIVE POWER

BOILERS

ENGINES, SHAFTING

DRIVING

## VENTILATION AND HUMIDIFYING



The following notes are intended to convey a general idea of how the different departments in a cotton mill should be dealt with, in regard to ventilation, and the removal of steam, dust, etc., from the workrooms.

**Card Rooms.**—Fans 24 in. and 30 in. dia. are usually adopted for removing the floating dust in the card room. They are invariably placed in the window recesses, on the side of the carding engines opposite to that on which the preparing machinery stands.

**Mule Rooms.**—Small fans are usually installed in these rooms in order that a good distribution of air may be secured without perceptible draught.

**Ring Rooms.**—To reduce the high temperature usual in these rooms, it is advisable to use fans for forcing in and distributing the fresh air from the outside.

**Gassing Rooms.**—Fans should be fixed in the roof of the building and fresh air inlets provided underneath each frame, so that the air in its passage to the fan carries with it the fumes and calcined fibres.

**Sizing Room.**—The steam given off by the sow-box and drying cylinders of the machines should be removed by fixing a fan in the existing trunks. Where there are a number of machines, the trunks from each may be connected to one main trunk, and a larger fan should be used for the installation.

**Steam Removing Generally.**—The sources of steam should be hooded over, with a fan fixed inside every hood for drawing away the steam. The air entering the room where the steam is made should be warmed as it enters, by being confined and passed over heated surfaces, such as steam pipes, etc.

### "HUMID" COTTON CLOTH FACTORIES.

#### Ventilation and "Steaming."

The legal requirements are:—"The arrangements for ventilation shall be such that during working hours in no part of the cotton cloth factory shall the proportion of the carbonic acid (carbon dioxide) in the air be greater than nine volumes of carbonic acid to every 10,000 volumes of air." It has, however, been the practice of the Department, with the assent of the employers and operatives, to regard the air of a weaving shed as

substantially conforming to the standard if the proportion of carbonic acid does not exceed that in the open air by more than 5 parts in 10,000. This object is generally attained by fixing a number of small fans, well distributed for forcing fresh air into the shed, and calculated to supply 2,000 cubic feet of air per hour to each person.

### HUMIDIFICATION.

A Humidifier should give just the right degree of humidity to the atmosphere without involving the risk of drops falling on to the goods or machines below, and should at the same time act as a Ventilator. The water should be reduced to an infinitely fine state of division—more like mist or fog than spray; and the atmosphere for each particular process should be so arranged and maintained as to give the best possible conditions all through the year, irrespective of outside atmospheric conditions. The air entering the humidifier should at all times be filtered.

The number of humidifiers required naturally varies with the climatic conditions, but for Lancashire it may be stated approximately as follows:—

Conditioning Room, 1 humidifier to 900 sup. feet of floor.

Carding and Preparing Room, 1 humidifier to 2,000 sup. feet of floor.

Mule Spinning Room, 1 humidifier to 2,000 sup. feet of floor.

Ring Spinning Room, 1 humidifier to 800 sup. feet of floor.

Winding and Warping Room, 1 humidifier to 1,600 sup. feet of floor.

Weaving Room, 1 humidifier to 1,200 sup. feet of floor.

The above table refers particularly to the "Vortex" system of humidification, which may be taken as typical. This humidifier works without steam or compressed air, and is fitted with a self-cleansing filter, which cleans itself automatically each time the humidifier is started or stopped. The water is supplied to the humidifier under a pressure of 100 to 140 lb. per square inch, by means of a force pump.

The quantity of water consumed will vary with the state of the atmosphere and its temperature; but  $1\frac{1}{2}$  gallons is estimated as the medium per hour for each humidifier, with a maximum of  $2\frac{1}{2}$  gallons per hour.

**Humidity Table for Attaining Good Results.**

At Temperatures varying from 100 deg. to 40 deg. F.

Dry Bulb.	Wet Bulb.	Relative Humidity.	Weight of Vapour Grains.	Dry Bulb.	Wet Bulb.	Relative Humidity.	Weight of Vapour Grains.
100°	85.5°	46%	9.2 grs	70°	60.0°	53%	4.3 grs
99	84.0	46	9.0	69	59.0	53	4.1
98	83.6	47	8.8	68	58.3	53	4.1
97	82.3	47	8.6	67	57.3	53	3.9
96	81.3	47	8.3	66	56.3	53	3.8
95	81.0	48	8.3	65	55.5	53	3.7
94	80.0	48	8.0	64	54.5	53	3.5
93	79.0	48	7.8	63	53.7	54	3.4
92	78.6	49	7.7	62	53.0	54	3.4
91	77.7	49	7.6	61	52.0	54	3.2
90	76.7	49	7.3	60	51.0	54	3.1
89	76.3	50	7.2	59	50.3	54	3.1
88	75.3	50	7.0	58	49.3	54	3.0
87	74.6	50	6.9	57	48.3	54	2.8
86	73.5	51	6.6	56	47.5	54	2.7
85	72.6	51	6.5	55	46.7	55	2.6
84	72.0	51	6.3	54	46.0	55	2.6
83	71.0	51	6.1	53	45.0	55	2.5
82	70.0	51	5.9	52	44.3	55	2.5
81	69.3	51	5.8	51	43.5	56	2.4
80	68.6	52	5.7	50	42.5	56	2.3
79	67.7	52	5.5	49	41.7	56	2.2
78	66.7	52	5.4	48	41.0	57	2.2
77	65.7	52	5.2	47	40.2	57	2.1
76	65.0	52	5.1	46	39.2	57	2.0
75	64.0	52	4.9	45	38.4	57	2.0
74	63.0	52	4.7	44	37.8	58	2.0
73	62.3	52	4.6	43	36.8	58	1.9
72	61.3	52	4.5	42	35.6	58	1.8
71	61.0	53	4.4	41	35.0	58	1.7
				40	34.2	58	1.6

For ascertaining the percentage of moisture in cotton mills, it is necessary to use Hygrometers. These are usually composed of two bulb thermometers (one wet and one dry) carefully graded on their own separate stems. The bulb of the former is covered with a small piece of muslin, which is kept moist by connection with a small reservoir of clean soft rain-water (or distilled



water) directly underneath. Both thermometers are mounted independently, and the temperatures of air and evaporation are given by the direct readings of both. By comparing these readings with tables provided with the instrument, the percentage of humidity is ascertained.

An instrument is now made which dispenses with the need of the above tables.

---

## SPRINKLERS.

The ever-increasing use of sprinklers in mills and industrial works generally is due to the fact becoming more widely known that it is not alone the fire loss that has to be guarded against—(this can be covered by insurance)—but also the absolute dislocation of business and the loss of customers, which is not covered by the insurance.

Of the 38 million spindles represented by the English Federation of Master Cotton Spinners' Associations, 88 per cent. are protected from fire by automatic sprinklers. The installation of sprinklers in a textile mill reduces the premium for insurance by from 33 per cent. to 50 per cent. It is also to be borne in mind that when a fire starts and operates a sprinkler immediately, it also operates a fire-alarm, thus drawing attention to the outbreak, even when the work is not in progress, and the mill is empty of people; and the same alarm will be raised to sound if any leakage should accidentally occur in the installation.

Sprinklers should be installed in accordance with the rules of the Fire Insurance Companies, which lay down that the horizontal distributing pipes to which the sprinkler "heads" are attached shall be fixed at intervals of 8 to 10 feet along the ceiling of each room. In textile factories one sprinkler head protects 100 superficial feet of floor area; and a pressure of 10 lb. per square inch has to be maintained at the highest sprinkler of the installation. Allowing for bends, contractions in the pipes, and friction, this requirement means that a pressure of from 80 to 100 lb. per square inch has to be maintained in the rising main. This may be effected by direct connection to the public supply, or to a tank on the top of the building, or by a pump.

This latter can readily be arranged to start working automatically, its action being ingeniously controlled by the pressure of the water in the pipes themselves. The capacities of the tanks—which should be so placed that the bottom is 15 feet above the highest sprinkler head—are as follows:—

- For not more than 150 Sprinklers on one floor,  
5,000 gallons.
- For not more than 200 Sprinklers on one floor,  
6,500 gallons.
- For more than 200 Sprinklers on one floor,  
7,500 gallons.

-----

**Electric Fire Alarm.**—This apparatus consists of copper tubing, 1/10th inch in diameter, which is carried round the rooms of a building in the same way as an electric wire. Both ends of the tubing go to a switch-board, where one is joined to a detector. This detector consists of a chamber, one side of which is made of a thin sheet of mica. Above this chamber are arranged two contacts, so that when the air in the tubing is expanded by sudden heat, the pressure causes the mica to bulge, and thus to complete an electric circuit. The contact thus made operates an alarm bell or gong, which may be fixed in any convenient part of the building. The apparatus can be used along with a sprinkler installation, or independently. It is very quick in its action, and does not interfere with the usual arrangements of a building.

-----

## MILL LIGHTING BY GAS

In dealing with gas lighting under ordinary conditions, *i.e.*, with the supply from the mains under varying pressures, the use of pressure governors is very desirable. These usually consist of a steel dome, within which is an inverted cup sealed in an annular trough and filled with mercury. To the cup there is attached a spindle, at the base of which is a double-beat valve. The gas enters by a junction pipe at the base of the apparatus, and passing the valve, presses the inverted cup upwards. The pressure permissible is adjusted by weights placed over the head of the spindle above the inverted cup. When

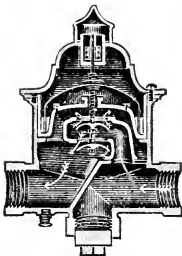

then it exceeds the amount thus determined, the cup instantly rises, partially closing the valve, and proportionately reducing the pressure passing inwards towards the burners. If 50 out of 100 lights are turned off, there will be a corresponding increase of pressure on the cup, and the valve operates to limit the inflow accordingly; so, too, with increased pressure from the main.

Lighting by gas has received a great impetus by the introduction of the incandescent mantles, which not only increases the illuminating power of the burner, but effects a great saving in the gas consumption.

Its extended adoption is still further assured by the advent of what is called the intensified light. This is a combination of the incandescent mantle with the use of ordinary gas at an increased pressure, obtained by an apparatus which may be worked from the town's water mains. The increased pressure, by operating in conjunction with a special burner, insures enough air being drawn in and mixed with the gas to give complete combustion. By this arrangement a brilliant and diffused light is obtained from a comparatively small quantity of gas.

### Gas and Air Mixing Apparatus.

**Function.**—To produce intensified gas-lighting by mixing gas and air in definite proportions, and supplying the mixture under pressure through ordinary gas pipes to burners provided with incandescent mantles.

**Description.**—The gas as it comes from the town's main is reduced to atmospheric pressure, and is then mixed with air in the proportion of 3 parts air to 1 of

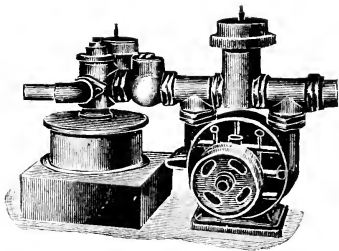

gas. The mixture then passes through a compressor, whence it is discharged through the service pipes to the burners at a pressure of 10-inch water column. To keep

the pressure uniform (not variable when lights are shut off or increased), the apparatus is provided with a governor. The apparatus may be driven in any ordinary manner, and is well adapted for mill and works lighting.

Speed, about 550 revolutions per minute.

## WATER POWER DRIVING

Where water power is available for driving cotton machinery, it is by far the cheapest motive force to adopt. With a good turbine it is computed that from 70 to 80 per cent. of the energy passing into it can be utilised—which is a percentage greatly in excess of that derived from any other form of motive power. When the supply of water can only be obtained during certain months of the year, it is customary to have a supplementary steam power plant for use during the intervening months, or whenever the water supply may fail.

### MEASUREMENT OF WATER.

#### IN A RUNNING STREAM.

Choose a part of the stream where the section is fairly regular, mark off (say) 20 yards along the bank. Throw a float into the stream and note how long it takes to travel the distance set out. (A bottle sunk down to the cork makes a good float for this purpose.) To get the average speed, repeat the operation two or three times.

The speed thus measured is that of the surface near the centre of the stream, and is where the water moves the fastest. Near the bottom and at the sides it flows more slowly, the difference depending upon the nature of the channel. If the channel is a wooden trough with smooth sides and bottom, take off 15 per cent. from the speed ascertained as above; if a brick channel, 17 per cent.; if the bottom and sides are earth, 29 per cent.; and in rough mountain streams 36 per cent. may be taken off the speed. From the average section of the stream calculate the area, then treat the figures as shown in the following example:—

Suppose the speed in the middle of the stream to be 100 feet per minute and the channel to have an earth bottom and sides, and the area of the stream to be 18 square feet—Reduce the speed 29 per cent., which leaves 71 per cent. per minute. Multiply this by 18 feet, the area. The result is 1,278 cubic feet per minute.

## OVER A WEIR, BY-WASH, OR NOTCH.

The mode of procedure is to ascertain the quantity of water from the overflow or weir. When no weir or by-wash exists, put planks across the stream, and make a rectangular notch, sufficiently wide and deep for the whole of the water to pass through. The water must be dammed back until it is as nearly as possible in the condition of a still reservoir, having little or no sensible velocity of motion until it approaches the overflow. Ascertain the width of the overflow and the exact depth. The quantity of water can then be calculated. The depth of the overflow, however, must be taken some distance back from the weir: *i.e.*, before the water begins to curve downwards. After ascertaining the depth of the overflow, the following table may be made use of:—

TABLE OF DISCHARGE FROM EACH FOOT OF WIDTH OF SILL. IN CUBIC FEET PER MINUTE.

Depth of Overflow in inches.	Fractions of an inch.			
	0	$\frac{1}{4}$	$\frac{1}{2}$	$\frac{3}{4}$
0	0	·596	1·69	3·1
1	4·78	7·46	9·83	11·1
2	13·5	16·1	18·9	21·7
3	24·8	28·0	31·2	34·6
4	38·2	41·7	44·5	48·9
5	53·4	57·4	61·4	65·4
6	69·4	74·1	78·8	83·6
7	88·4	93·3	98·2	103
8	103	113	118	123
9	129	134	139	145
10	151	156	162	168
11	174	180	186	192
12	198	204	210	217
13	224	230	236	243
14	250	256	263	270
15	277	284	291	298
16	305	312	319	326
17	334	341	348	356
18	364	371	379	387
19	395	403	411	419

## TURBINES AND OTHER FORMS OF MOTORS.

There are two classes of turbines or motors, viz.:—those in which there is and those in which there is not, a pressure in the clearance-space between the guide blades and the wheel. The former are called "Pressure" or "Reaction" turbines and the latter turbines of "Free Deviation."

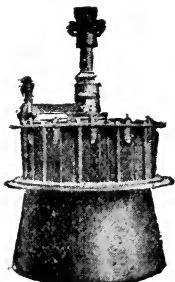

"Reaction" turbines may be subdivided into two types—single-flow and mixed-flow. In the former the water leaves the wheel in the same direction as the inflow, and in the latter in a different (or, partly the same and partly different) direction.

In all "reaction" turbines the water passes first through a series of guide vanes, which may either be fixed or moveable, and which direct the flow of the water at the correct angle into the buckets of the wheel. All turbines of this type can also be used in connection with a suction tube, and may be placed some distance above the actual tail water level,

the full effect of the whole fall being in all cases obtained. The maximum height of suction advisable in practice is from 20 to 25 feet.

Single-flow turbines are of two classes:—(1) Radial, in which the water flows through the wheel in a direction at right angles to the shaft; and (2) Axial, in which the direction of flow is parallel to the shaft.

The "Vortex" turbine is an example of the radial single-flow turbine, and is constructed on either vertical or horizontal shafts, with single wheels in the case of the vertical, and double wheels in the horizontal type. The water is directed on to the wheel by a series of moveable guide vanes, generally about four in number. After passing through the buckets it flows away through a central opening, downwards in the case of the vertical shaft single wheels, and discharging equally on either side in the case of the double horizontal wheels. The vertical shaft type wheels are suitable for low falls up to (say) about 12 to 15 feet; and the horizontal type for the higher falls—up to about 200 feet.

The Mixed-Flow turbine is known as the American type, of which the "Lefel" and "Ridson" are some of

the earliest examples. This type of wheel has been designed in order to obtain a much larger power from a wheel of a given diameter than is possible with either of the single-flow types, and is specially adapted for the water power of large electric lighting and power transmission installations. Of the latest of this type of turbine is the "Samson," which is an improvement and modification of the original Leffel turbine. In this turbine the water enters the wheel radially and discharges partially radially and partially axially. The turbines are fitted with adjustable guide-blades, generally about twelve in number, by which the water is directed into the buckets of the wheel. The turbines are made on vertical or horizontal shafts, the vertical having single wheels and the horizontal sometimes single and sometimes double wheels.

For low falls (of from 2 ft. up to 15 ft.) the vertical type is most generally used, and for falls of from 15 ft. upwards the horizontal shaft wheels are suitable, but this depends very largely on local conditions.

For fairly high falls (of from 60 to 70 ft. and up to 300 or 400 ft.) special wheels are constructed, with buckets made to discharge in both directions, in order to neutralise the end thrust.

For high falls (say of 100 ft. and over), when only small power is required, a reaction turbine is difficult to use, owing to the very high speed at which it runs. In such circumstances some form of "Impulse" turbine is advisable, such as the "Pelton" wheel, the "Gerard," and the ordinary water-wheel.

The "Pelton" consists of a series of buckets mounted round the rim of the wheel itself, and supplied with water through one or more nozzles. The water from jets impinges on the buckets and is divided by a central plate which deflects the water off on to either side of the wheel.

#### The "Gerard."

The GERARD (like the Vortex) is made to work with the shaft either horizontal or vertical. There is no pressure between the guide-blades and the wheel, and as the water enters the buckets it is freely deviated by them and takes a course quite independent of their shape.

The ordinary water-wheels are made in several types, generally known as the "under-shot," "low breast," "high breast," and "over-shot." In nearly every case,

however, a considerable advantage can be gained by a turbine over a water-wheel, both as regards adaptability and amount of power developed from a given quantity of water.

Water-wheels are also seriously affected by any rise in the tail water level; whereas with turbines of the reaction type the only difference made to their working by a rise in the tail level is to reduce the working fall by a proportionate amount. And if there is, with a rise in tail, a corresponding rise in the head level, the turbine will work exactly as if under normal conditions.

The efficiency of various forms of motors are as follows:—

Under-shot Water-wheel	.....	30 to 40	per cent.
Low Breast	„	45 „ 50	„
High Breast	„	50 „ 60	„
Over-shot	„	60 „ 70	„
Turbines of all types	.....	70 „ 80	„

*Note.*—Cubic feet per min.  $\times .472 =$  Litres per second.

### USEFUL MEMORANDA FOR HYDRAULIC INSTALLATIONS.

1 Foot = 12 inches = .305 metres.

1 Cubic foot of water = 6.24 gallons (say  $6\frac{1}{4}$  gallons)  
= 28.3 litres = .0283 cubic metres.

1 Cubic foot of water weighs 62.5 lb.

1 Metre = 39.37 inches = 3.28 feet.

1 Cubic metre of water = 1,000 litres = 1,000 kilos.  
= 35.32 cubic feet = 220 gallons.

1 Cubic metre of water weighs about  $1\frac{1}{2}$  per cent. less than 1 ton.

1 Litre of water = .001 cubic metres = .035 cubic feet  
= .22 gallons.

1 Litre of water weighs 1 kilogram = 2.204 lb.

Litres per second  $\times 2.12 =$  cubic feet per minute.

Cubic feet per minute  $\times .472 =$  litres per second.

1 Gallon of water = .16 cubic feet = 4.543 litres.

1 Gallon of water weighs 10 lb.

Pressure in lb. per square inch = head of water in feet  $\times .433$ .

Pressure in lb. per square inch  $\times 2.31 =$  the corresponding head of water due to such pressure in feet.



When water is flowing through a pipe at 3 feet per second, the quantity delivered per minute = approximately the diameter of pipe in inches squared.

1 Horse-power = 33,000 foot lb. per minute = 550 foot lb. per second.

1 French horse-power = 75 kilogrammetres (the weight of 75 litres of water falling 1 metre) per second = 542.5 foot lb per second.

To Ascertain the Horse-power, where Q = cubic feet per minute, and F = fall in feet:

$$\frac{Q \times F}{706} = \text{H.P.}$$

To Ascertain the Quantity of Water required for a given power:—

$$\frac{\text{H.P.} \times 706}{F} = \text{Quantity in Cubic Feet per minute.}$$

To Ascertain the Height of Fall in feet required to produce the H.P.:—

$$\frac{\text{H.P.} \times 706}{Q} = \text{Fall in Feet.}$$

1 French horse-power at 75 per cent. efficiency =  

$$\frac{\text{Litres per second} \times \text{Fall in Metres.}}{100}$$

The foregoing figures are based upon 75 per cent. efficiency. For 80 per cent. efficiency take 660 as the constant, and for 70 per cent. efficiency take 734 instead of 706.

---

The cost of providing power for a room full of ring spinning frames, water driven direct by independent turbines, including foundations, water channels, and piping, is about £30 per frame. Pressure of water 168 lb. per square inch, and water consumption 4.22 litres per second. Effective power of turbine for a frame containing 416 spindles 4.5, with a water fall of about 380 feet.

## GAS POWER

The gas engine is now in use in sizes up to 5,000 horse-power units. It is an economical prime mover, and has now established itself as a commercial success. Many steam-engine builders are now taking up the construction of large gas engines.

**Economy.**—With gas-engine driving the economy in fuel is much greater than with the steam engine. Taking an average figure, it is estimated that 1 H.P. can be generated at one-half the fuel cost of that which is required for the steam engine, which is an important item in sizes of about 1,500 H.P. and upwards. A further saving can be effected by the recovery of ammonia by-products, which in some cases amount in value to almost that of the coal itself.

Gas producers are made to use (and are working successfully) with such fuels as peat, wood, sawdust, lignite, waste coke, cotton seeds, etc.; as also, of course, to coal itself.

**Installation.**—The complete installation of a gas-driving plant is self-contained. It consists of the generator, which takes the place of the steam boiler, and the engine proper. The space taken is about equal to that occupied by the boiler. There is no chimney required, nor reservoir for condensation.

**Labour.**—About the same as that required for a steam plant, but the work is much lighter.

**Up-keep.**—Considerably less than a steam plant.

**Steadiness of Running.**—Is assured by the improvements recently made therein.

**Exhaust Gases.**—The exhaust gases from the engine can be utilised to generate steam for heating and other purposes for which steam may be required. The apparatus used for raising the steam is also provided with a fire-grate, so that steam may be generated when the engine is standing at the week-end, or when an extra supply is required during working hours.

### Gas Producers.

**Types.**—Pressure Bituminous.

Suction Bituminous.

Suction Non-Bituminous.

**Pressure Bituminous.**—Uses ordinary steam coal, and consists of a producer through which air and steam are blown in the generation of the gas and a purifying apparatus. There are several types of the latter, but

the simplest consists of a series of atmospheric coolers, through which the gas passes from the producer. The gas is cooled to atmospheric temperature, and at the same time deposits any tar, which latter is run away to a sump in the ground. The gas passes to a water washer, and forward into the gas-holder, through a saw-

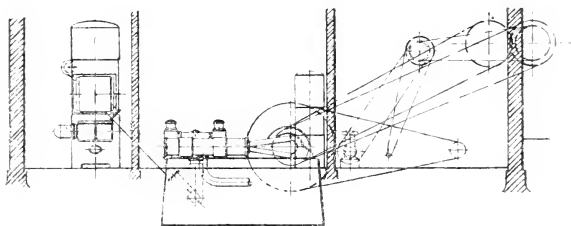
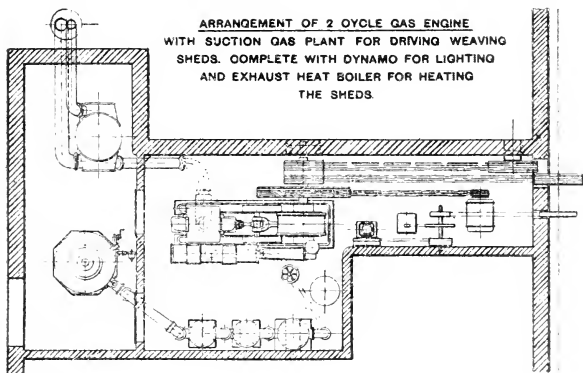

dust drier. This plant is simple, and there are no duplicate parts to get out of order.

**Suction Bituminous.**—Also uses ordinary steam coal, except the kind that has a tendency to cake. In principle it is much the same as that of the pressure type, except that the gas-holder and blower are dispensed with. In this system the air and steam are drawn through the producer by the suction of the engine

piston, or, when two-cycle engines are used, by the pump on the engine. By this latter method there is more regular suction and a greater power is obtained.

**Suction Non-Bituminous.**—Only uses such fuels as anthracite coal or coke. In other respects the principle involved is much the same as in the foregoing plants, except that the purifying apparatus is simpler, because there is no tar deposit to get rid of.

### The Gas Engine.

**Types.**—Two-Cycle.  
Four-Cycle.

**Two-Cycle.**—The action of the valve is the same as in a steam engine, and every stroke is a driving stroke. Each charge of gas is put into the cylinder by means of a separate pump, and enters therein under a few pounds pressure. The charge is further compressed in the main cylinder, as in the four-cycle engine. This method reduces the strain on the engine, and having a large number of impulses per cylinder, it is enabled to run very steady.

**Four-Cycle.**—When worked on the double-acting principle, only each second stroke is a power stroke, because the piston must push out the burnt charge before a new supply can be sucked in the cylinder. In small engines, where the principle is invariably single-acting, every fourth stroke only is a power stroke. This type of engine is usually fitted with a heavy fly-wheel to steady the running.

Some makers arrange the four-cycle single-acting cylinder vertically, and obtain a steady drive by multiplying the cylinders instead of using the fly-wheel.

## BOILERS, ENGINES, SHAFTING

### STEAM BOILERS.

The "Lancashire" or shell boiler is the type commonly used in generating steam for cotton mills, and the particulars given in the following pages have special reference thereto:—

**Sizes and Pressures.**—With the introduction of steel plates for the shells, and the use of machine-riveting,

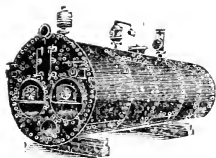

boilers of the Lancashire type are now made in sizes from 6 ft. 6 in. dia. by 20 ft. length, to 9 ft. dia. by 32 ft. length, and are capable of withstanding pressures of from 160 and 180 lb. per square inch.

**Mounting.**—In mounting a boiler, it is advantageous to make the shape of the side flues follow as nearly as possible the curvature of the boiler. There is then less liability for the accumulation and deposit of soot about the plates.

#### Points :

Flues should be thoroughly swept periodically, the bridges and fire-bars being removed. Never remove the mid-feather wall from the down-take flue.

It is a wise precaution to lift safety valves slightly and test gauge cocks daily, to make sure that they are in working order.

To remove deposit in boiler open blow-off tap occasionally.

A good disincrustant is common soda or soda-ash.

To burn coal economically, the flue gases should contain about 16 per cent. of carbon dioxide. In actual practice, however, the gases seldom contain more than 5 per cent.

From 18 to 20 lb. of coal per foot of grate-space is the amount of evaporation of a good Lancashire boiler.

### MECHANICAL STOKERS.

**Function.**—To increase the efficiency of steam boilers, to economise coal consumption, and to abolish smoke nuisance.

#### Types.

**Coking Stokers.**—In these the coal is pushed on to the furnace in a mass from the front of the boiler, and becomes partially coked before reaching the fire. It is practically smokeless, and is very effective for light loads, where there is ample boiler power and a regular steam demand.

**Sprinkler Stokers.**—In this type the coal is spread over the surface of the fire in small quantities at regular intervals, resulting in a constant blazing fire and high furnace temperature. It is to be preferred where there

is a fluctuating steam demand, or where the boilers have a heavy load and are hard fired.

A good sprinkler will burn up to 40 lb. slack coal per square foot of grate area with natural draught, increasing the efficiency of the boiler from 10 to 30 per cent., according to conditions, and at the same time maintain-

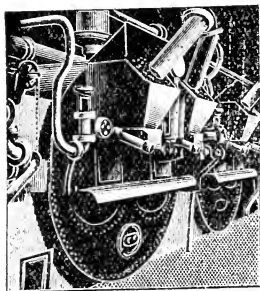

ing a good average  $\text{CO}_2$  record. Low-grade small slack unsuitable for hand-firing can be efficiently burned by using mechanical stokers.

**Boiler Powers.**—References to following table:—

- |    |   |
|----|---|
| A  | } Engines of different degrees of wastefulness.   |
| B  |   |
| C. | —Good average modern compound engine, 100/140 lb., no superheat.  |
|    | ( First-rate compound engine, 150 lb., no superheat.  |
| D  | — Good average modern compound engine, 100/140 lb., superheated.  |
| E. | —Exceptionally good compound engine, 160 lb., no superheat.   |
| F. | —First-rate triple-expansion engine, 180 lb., no superheat.   |
| G  | } Exceptionally good compound or triple-expansion engines, 160 lb. to 200 lb. pressure, considerable superheat. |
| H  |   |

Additional allowance must be made for heating and steaming the mill, etc.

**Boiler Powers.**—The following table supposes economisers, the use of ordinary COAL, and a reasonable DRAUGHT:—

Dia.	Length	Lb. water evaporated per hour.	A	B	C	D	E	F	G	H
ft. in. 6 6	ft. in. 20 0	3600	100	200	240	250	280	300	320	350
„	22 0	3850	100	200	250	280	300	320	340	370
„	24 0	4200	120	220	280	300	320	350	375	400
„	26 0	4540	130	230	300	330	350	380	400	430
7 0	24 0	4800	150	260	320	340	370	400	420	450
„	26 0	5200	160	280	340	370	400	430	450	490
„	28 0	5500	170	300	370	390	420	460	480	530
„	30 0	5900	180	320	400	420	450	490	500	570
7 6	26 0	5500	170	300	370	390	420	460	480	530
„	28 0	6000	180	330	400	430	460	500	510	590
„	30 0	6500	200	350	430	460	500	540	546	640
8 0	28 0	6500	200	350	430	460	500	540	546	640
„	30 0	7000	200	360	470	500	540	580	600	690
„	32 0	7500	220	400	500	530	570	610	630	720
8 6	30 0	7400	220	400	490	520	550	600	620	710
„	32 0	8000	250	430	520	540	590	630	660	750
9 0	30 0	8250	260	450	535	560	600	650	680	770
„	32 0	8700	270	470	560	590	640	680	700	800

INDICATED HORSE-POWER.

### Induced Draught for Boilers.

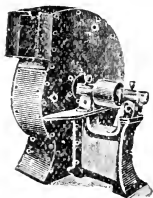

Induced Draught is obtained by means of a fan, which is placed in such a position that it will draw the gases from the flue after they leave the Economiser, and will deliver them back into the flue nearer the chimney. A damper is placed between the point at which the gases are drawn into the fan and the point where they are discharged from the fan.

The advantages claimed for the application of Induced Draught are:—

1. Increased draught.
2. Better and more efficient combustion.
3. Elimination of black smoke.
4. Increased steaming power of boilers.
5. Independence of atmospheric conditions.
6. Economy of fuel.

With induced draught, thicker fires may be used, and a higher temperature in the furnace is obtained. The air as it is drawn through the incandescent fuel is more easily split up, and combines more readily with the carbon in the coal—thereby producing more perfect combustion and attaining the objects claimed in No. 3 and No. 5 respectively.

Should the demand for steam be not greater after the Fan is installed than before its installation, the almost invariable rule is to shorten the grates of the boilers.

With an Induced Draught Fan it is often found practicable to add to the size of the Economiser, thus making for greater economy.

### Superheated Steam.

The use of superheated steam, properly applied in the right case, results in a considerable reduction of the coal consumption. But it should be noted that, even with superheated steam, a low steam consumption does not necessarily mean a low coal consumption. Superheating almost always pays well in cases where there is room for a great improvement, such as with single-cylinder engines, very low pressures, engines very much underloaded, boilers very much overloaded, or cases in which the engine is at the end of a long range of steam piping. It pays less well, if at all, when applied to triple-expansion



engines, unless considerably underloaded; or to overloaded compound engines, unless at very low pressures; or with very lightly-fired boilers. There are, of course, exceptions to this broad rule, but not very many.

Where superheaters are used, care should be taken to lubricate the engine efficiently, the oil being, if possible, fed directly on to the valves at each cylinder end. Slide and piston valves are not generally suitable for superheated steam. If the engine is at the end of a long range of steam pipes, there may be no superheat left, and still be a gain in economy.

Great care should be taken in arranging steam pipes where superheated steam is to be used.

### Scientific Control in the Boiler Room.

There are now in use in a large number of mills throughout the country scientific recording apparatus of various kinds, designed to secure improved economy in the boiler-room without necessitating structural alterations. Among these, Combustion (CO<sub>2</sub>) Recorders are the most prominent; and the remarkable economies which it has been possible to effect by their judicious use, certainly make it desirable that every millowner should closely investigate their merits as applied to his own power plant.

Other devices that call for mention under this heading are Draught Gauges, and (more particularly) Draught Recorders, Water Meters, Steam Load Recorders, etc.

With regard to the latter, there is an instrument now available which measures the quantity of steam flowing through a pipe with remarkable accuracy. It enables engineers to obtain reliable data as to the various sections of a steam plant or the amount generated by the various units of a battery of boilers. This instrument is sold under the name "Sarco."

---

### Useful Maxims to be observed in the Engine and Boiler Houses:—

1.—Where coal is cheap, extreme "economy" sometimes costs more than it is worth.

2.—Friction not only costs money for coal and oil, but it uses the extra power in wearing out your plant.

3.—There is more virtue in two extra bolts to a pipe-joint than in all the patent joining material on earth.

4.—A permanent difference in price is a permanent difference in quality.

- 5.—Spur and bevel wheels are articles of consumption.
- 6.—Dirt is the prophet of the break-down.
- 7.—The man who experiments with his plant is a benefactor to his competitors.
- 8.—You may not want spare air-pump valves, but if you do, you will want them badly.
- 9.—A broken crank-pin step will run for years, if it can see a spare one in the engine house ready to take its place. If not, it won't.
- 10.—A small air-leak in your injection-pipe will add 5 per cent. to your coal bill; and it is very bad to get at, so lay them carefully.
- 11.—Check the pressure gauges on your boilers by an indicator; they are almost sure to be wrong.
- 12.—Spare catch-plates, buffer springs, etc., should be fitted into their place and then stored; otherwise they won't go in when they are wanted and the mill will stand.
- 13.—Cast-iron pillars out of doors frequently contain water. If holes are drilled at the bottom they can't; so they don't burst in a frost.
- 14.—Engines on coal-fields should be levelled up periodically. The cost is small, and the evidence, in case of subsidence, priceless.
- 15.—If your engine is not fitted with a vacuum breaker and steam cut-off, for top and bottom governor-positions, it is not safe.

In the first of the foregoing maxims it is stated that, when coal is cheap, extreme "economy" costs more than it is worth. That is to say there are cases where an extra two or three hundred pounds, or even more, is invested to get a shade lower steam consumption on a trial,—although the result, taking a month's run of the mill, shows that the saving in coal due to the extra elaboration does not pay good interest and depreciation on the extra cost. Manufacturers should watch this point, taking into account the price they pay for their coal, and particularly satisfying themselves that the extra elaboration does not in any way increase the risks of stoppage: for if it stop the mill for one extra day in the year, it may easily wipe out the whole of the saving that it was put in to effect. The cost of stoppages should be debited to its proper place—that is, to the cause of the stoppage.

#### Economisers.

Fuel Economisers are fitted to almost all cotton mill boilers. They are usually made with 4 to 10 pipes in a row, 8 being the most convenient number. These rows are arranged side by side to the required number. A 350 I.H.P. boiler would require 112 tubes or 8 rows of 8 tubes each.



If a passage is required at the back of Economiser for inspection and cleaning, 9 in. extra must be added to above sizes.

### Steam Condensation Receiver.

**Function.**—Collects the water of condensation from steam-heating systems, and generally enables same to be used again. When collected at high temperatures, a great saving may be effected in coal consumption. This water is in the best possible condition for boiler-feeding, owing to its temperature and its purity.

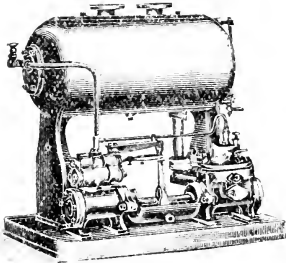

**Description.** — Is usually made to work in conjunction with a pump, and is provided with controlling mechanism to regulate the steam supply to the pump, as the water

risers or falls in a receiver into which the condensation runs. A float-and-lever arrangement controls the steam valve.

**Production.**—Made in three sizes, to deal with 500, 1,000, and 1,500 gallons of condensation per hour, respectively, at 50 lb. pressure or over.

### Water Cooling Plant.

Water-cooling devices may be adopted with advantage by steam-users having condensers the water-supply of which is limited, or is obtained from towns' mains at considerable cost. They effect great economy by making it possible to use the water over and over again. In addition to the recognised methods of cooling water in ponds and by means of sprayers, resort may be had to cooling-towers of special design and construction. These latter not only take up considerably less ground area than do ponds, but they are more effective for the purpose.

**Function.**—The function of water-cooling towers is to bring the warm water into contact with cold air, and thus effect the cooling of the former by causing the heat to be taken up by the air. By an arrangement of troughs, the water to be cooled is distributed over the entire area of the tower, and descends in the form of rain in equal quantities at all parts of the cooler. As

the water falls, it encounters the cool air that is making its way out at the top of the tower.

**Types.**—There are three types of cooling towers, viz.:—

1st: Natural Chimney-draught Towers.

2nd: Forced or Fan-draught Towers.

3rd: Open-air Cooling Towers.

The **FIRST** (which are the most commonly used, and, as the title implies, depend only upon the chimney stack for the air current), under average conditions, reduce the temperature of water by about 40 deg. Fahr.—say from 120 to 80 deg. Fahr.

The **SECOND**, or forced-draught coolers, take up less ground-space than the former for a similar duty, but depend upon the aid of fans to produce the air draught.

The **THIRD**, or open-air towers, may be conveniently used where the advantages of the previous ones are not of great importance, and where the space available is not limited. The design is cheaper; and, the tower being light, it may be fixed on the roof of a building.

**Capacity.**—From 5,000 to any number of gallons of water per hour, according to size of plant.

## THE STEAM ENGINE.

**Output.**—The question of output from a certain number of machines is largely dependent upon the engine that produces motive power to drive them.

**Most Economical Load for Condensing Steam Engines.**—

The following table gives coefficients or multipliers, corresponding to different cylinders and pressures. By simply picking out the coefficient corresponding to a given low pressure, cylinder diameter, and the boiler pressure, and multiplying the piston-speed of the engine by this coefficient, the most economical load for that engine is found.

### Engine Indicating.

The importance of indicating an engine from time to time cannot be overestimated. A study of the diagrams taken enables an engineer to ascertain and establish various facts concerning the utilisation of the steam produced.

Diagrams show whether the valves of an engine are correctly and evenly timed. They serve as a guide for adjusting the valves

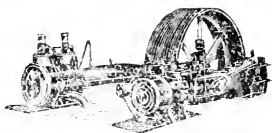

## ENGINE POWERS (Condensing).

Showing the Indicated Horse Power that should give the *greatest Economy* with given L.P. Cylinder and Boiler Pressure.

BOILER PRESSURES.

L. P. Cylinder Dia.	60	70	80	90	100	110	120	130	140	150	160	170	180	190	200
20 in.	.218	.236	.245	.251	.26	.264	.273	.28	.283	.286	.292	.298	.302	.308	.312
21 in.	.241	.26	.27	.277	.286	.292	.3	.308	.312	.315	.322	.33	.332	.34	.344
22 in.	.264	.285	.296	.305	.314	.32	.33	.338	.343	.346	.355	.362	.365	.374	.376
23 in.	.289	.312	.325	.333	.342	.35	.36	.37	.374	.377	.386	.394	.398	.406	.41
24 in.	.314	.34	.354	.362	.374	.38	.391	.403	.406	.41	.42	.43	.435	.443	.447
25 in.	.34	.368	.384	.393	.405	.412	.428	.437	.441	.446	.456	.465	.47	.48	.485
26 in.	.368	.398	.414	.425	.44	.445	.462	.472	.476	.485	.493	.505	.51	.52	.525
27 in.	.397	.43	.446	.457	.472	.48	.496	.508	.512	.52	.53	.542	.548	.56	.565
28 in.	.428	.461	.48	.492	.508	.518	.532	.548	.552	.56	.57	.582	.59	.602	.61
29 in.	.46	.495	.515	.528	.542	.552	.572	.588	.592	.6	.612	.625	.632	.648	.652
30 in.	.49	.53	.55	.565	.58	.592	.612	.628	.634	.642	.656	.67	.677	.692	.7
31 in.	.525	.568	.59	.604	.624	.632	.658	.672	.68	.685	.7	.716	.725	.74	.748
32 in.	.56	.602	.625	.64	.662	.672	.7	.715	.725	.73	.745	.762	.77	.788	.795
33 in.	.593	.642	.665	.688	.705	.718	.742	.76	.77	.78	.792	.812	.82	.838	.848
34 in.	.63	.68	.707	.725	.748	.76	.79	.808	.815	.824	.842	.863	.87	.89	.9
35 in.	.67	.72	.75	.77	.795	.81	.838	.86	.866	.872	.895	.915	.922	.942	.952

EXAMPLE:—Engine 15 and 27 in. cylinders, × 3 ft. 6 in. stroke, 77 revs., 120 lb. boiler pressure, = 539 × .496 = 267 I.H.P.

Take the number corresponding to your L.P. Cylinder diameter and your Boiler Pressure, and with it multiply your Piston Speed. The result is the best load in I.H.P.

## ENGINE POWERS.—Continued.

## BOILER PRESSURES.

L.P. Cylinder Dia.	60	70	80	90	100	110	120	130	140	150	160	170	180	190	200
36 in.	.705	.76	.79	.81	.84	.854	.882	.903	.914	.922	.942	.965	.975	.992	1
37 in.	.748	.81	.84	.86	.88	.902	.938	.96	.97	.98	1	1.02	1.03	1.05	1.07
38 in.	.788	.85	.885	.908	.94	.95	.985	1.01	1.02	1.03	1.05	1.08	1.09	1.11	1.13
39 in.	.83	.895	.935	.955	.985	1.01	1.04	1.06	1.08	1.09	1.11	1.13	1.15	1.17	1.18
40 in.	.87	.94	.98	1	1.03	1.05	1.09	1.12	1.13	1.14	1.16	1.19	1.2	1.23	1.24
41 in.	.92	.99	1.03	1.06	1.09	1.11	1.15	1.18	1.19	1.2	1.23	1.26	1.27	1.3	1.31
42 in.	.965	1.04	1.08	1.11	1.14	1.16	1.2	1.24	1.25	1.26	1.29	1.32	1.33	1.36	1.37
43 in.	1	1.085	1.13	1.16	1.2	1.22	1.26	1.28	1.3	1.32	1.35	1.37	1.39	1.42	1.44
44 in.	1.06	1.14	1.185	1.22	1.25	1.28	1.32	1.35	1.38	1.41	1.44	1.44	1.46	1.49	1.5
45 in.	1.11	1.19	1.24	1.27	1.31	1.34	1.38	1.42	1.44	1.45	1.48	1.51	1.53	1.56	1.58
46 in.	1.16	1.25	1.3	1.33	1.38	1.4	1.45	1.48	1.5	1.52	1.55	1.58	1.6	1.64	1.65
47 in.	1.21	1.3	1.35	1.39	1.43	1.46	1.5	1.54	1.56	1.58	1.61	1.65	1.67	1.7	1.72
48 in.	1.26	1.36	1.41	1.45	1.49	1.52	1.58	1.61	1.63	1.64	1.68	1.72	1.74	1.77	1.79
49 in.	1.31	1.42	1.47	1.51	1.56	1.59	1.64	1.68	1.7	1.72	1.76	1.79	1.81	1.85	1.87
50 in.	1.365	1.47	1.53	1.57	1.62	1.65	1.71	1.75	1.77	1.79	1.83	1.85	1.89	1.93	1.95
51 in.	1.42	1.53	1.58	1.63	1.68	1.71	1.78	1.81	1.83	1.85	1.9	1.94	1.96	2	2.02
52 in.	1.46	1.59	1.66	1.7	1.75	1.78	1.85	1.89	1.91	1.93	1.98	.02	2.04	2.08	2.1
53 in.	1.51	1.67	1.72	1.77	1.82	1.86	1.92	1.96	1.98	2.02	2.05	2.1	2.12	2.16	2.18

EXAMPLE:—Engine 25 in. and 48 in. cylinders,  $\times$  5 ft. stroke, 62 revs., 160 lb. boiler pressure,  $620 \times 1.68 = 1041.6$  I.H.P.

in order to get the best distribution of steam within the cylinder. They show the power developed in the cylinder, and indicate any loss that may arise from leakage, back pressure, or incorrect adjustment of valves. They show whether the steam ports and passages are of the right size, and indicate the condition of the valves and pistons. The indicator can also be used to test the influence of the feed-water upon the economical working of an engine.

In addition to its use in connection with steam engines, the indicator is serviceable in measuring and recording all pressures that are liable to variation.

#### DESCRIPTION.

The indicator produces its records by the aid of two motions, the resultant line being traced by means of a pencil upon a roll of paper, which is secured upon a cylinder or drum. This drum has a rotary and oscillating motion, at right angles to the motion of the pencil, from the crosshead of the engine or any part having a movement corresponding thereto. The movement of the pencil is actuated by the pressure of steam against a piston, having the resistance of a spring of known strength, and varies its position accordingly. As the drum containing the paper rotates, the pencil, actuated by the pressure of the steam in the cylinder, traces in outline the irregular diagram showing the working of the engine.

Before indicating an engine, open the cock, and allow steam to blow through the pipes to clear them of any scale or other kind of deposit. The indicator cylinder and piston should be carefully examined and cleaned. The piston springs used should be of the duplex type, *i.e.*, formed of two coils of wire fastened opposite each other, so as to equalise the strain put upon it by the piston.

The following are suitable lengths of diagrams with speeds of engine:—

Up to 300 revs. per min. ....	3½ in. long.
"   350      "      .....	3      "
"   400      "      .....	2½   "
"   450      "      .....	2¼   "
"   500      "      .....	2      "
"   550      "      .....	1¾   "
"   600      "      .....	1½   "
"   1000    "      .....	1¼   "

**Cost of Mill Driving.**—A set of engines of the triple-expansion type, over 1,000 H.P., used in driving a Lanca-



shire cotton mill, should not cost more than 5d. per horse-power per week, with coal at (say) 10s. per ton.

### Speed and Pressure Recorders.

**Function.**—To give a permanent record of every momentary variation in the speed of an engine, and of the pressure of steam in the boilers, together with the times of starting and stopping. The records are marked in diagrammatical form on strips of paper, which may be removed daily or weekly for entry into a book usually kept for the purpose. By the aid of these recorders, a system of regularity is ensured without the manager or overlooker having to keep a constant watch over the engineer in charge.

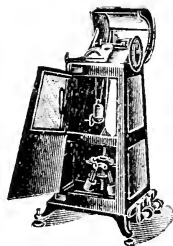

**Fixing.**—Usually on the engine crank shaft.

**Speed.**— From 84 to 92 revolutions per minute.

### SHAFTING.

The safe and satisfactory load for shafting depends greatly upon circumstances, and is a subject upon which there is a variety of opinions.

The tables on pp. 356 and 357 show the powers that can be satisfactorily put on to shafting, remembering that when necessary it must carry a belt-pulley, without vibration, in the middle of an eleven-foot span. This is a universal condition in mills and sheds, and rules that do not take it into account are wrong.

Textile machinery is constantly increasing in weight; —not that spindles are running heavier, but they are grouped in larger units. Accordingly, the shafting of a modern mill must be stiff and well made. It is not sufficient that shafting shall be put in just so strong that it will not twist off; if it is to be really satisfactory, it should be up to the standard of the List, so that it shall run well at high speeds, be rigid when machines reverse or go suddenly off and on, and give no trouble with its couplings. These are the weak links in the chain, and, together with every belt pulley, they will hold the

faster for being on a larger shaft. For this reason it is not safe to assume that a steel shaft will drive more than one of wrought-iron. It would, if there were no couplings; but not otherwise.

As stated at the foot of the table, it is not desirable that shafting under 3 in. should be used to drive mules of 1,000 spindles, and that no shaft under  $3\frac{1}{4}$  in. dia. should run as high a speed as 400 revs. per minute with 11 ft. bays.

**Shaft Lubricators.**—For applying lubricant to shafting automatically and continuously. They are worked by a screw-pressing action, which forces the lubricant into the bearing, while a delicate spring continues the feed after the screw-pressure ceases. The one illustrated consists of a shank, which is screwed to the bearing and is grease-tight. Screw c regulates the feed. A cap A is screwed on to the shank, and can be used to force the lubricant by direct screw-pressure. On the top of this cap is a raised cylinder, in which a cup leather piston B is actuated by a weak spiral spring, the piston-rod D passing through the top of the cylinder.



### Waste Oil Filter.

**Function.**—Separates and filters oil that has already been used, and purifies it sufficiently for second application.

**Description.**—The oil to be filtered is poured into an upper chamber, which is in the form of a sieve, whence it drains through a pad into a dish-shaped chamber. The oil then passes through a second pad into water, and works its way through a third pad into a chamber surrounding it. Here the oil floats on the top of the water, and eventually overflows down a tube into a second water tank. Ascending through another pad, the oil again floats and overflows down a second tube into a water tank at the bottom of the apparatus. The oil then ascends in a clarified state, and is drawn off at will through an ordinary discharge tap.

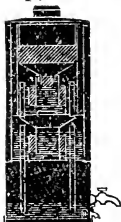

## FRICTION CLUTCHES.

By judicious adoption, friction clutches can be used with great advantage in cotton mills, bleach and dye works, etc.

In cotton mills each line shaft may be stopped independently by fixing a clutch at the driving end of the shaft.

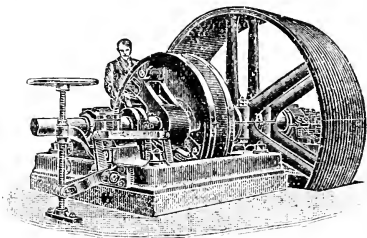

Dynamos may be driven direct from an engine, and through friction clutches may be started and stopped at will and without shock. Where gas, oil, or other combustion engines are used, clutches are a necessity to enable them to start well with the full load on.

Clutches are made in a variety of forms, and may be moved in and out of gear by lever, fork, or other suitable appliance. They prevent accidents which are liable to occur when moving belts or ropes from fast to loose pulleys.

They can readily be put in and out of gear when running at high speeds.

To work successfully, clutches should have no end thrust, and the gear should be capable of revolving in either direction. They should be well balanced, easy of adjustment, and self-contained, with efficient means provided for lubrication. Care should be taken that they cannot slide into gear without being operated.

---

## POWERS.

POWER OF SHAFTING. (11ft. bays.)  
SPEEDS.

100	110	120	130	140	150	160	170	180	190	200	210	220	230	240	250
2 in.	8 $\frac{3}{4}$	9 $\frac{1}{2}$	10 $\frac{1}{2}$	11 $\frac{1}{2}$	12	12 $\frac{3}{4}$	13 $\frac{1}{2}$	14 $\frac{1}{2}$	15 $\frac{1}{2}$	16	16 $\frac{3}{4}$	17 $\frac{1}{2}$	18 $\frac{1}{2}$	19 $\frac{1}{2}$	20
2 $\frac{1}{4}$ in.	11 $\frac{1}{2}$	12 $\frac{1}{2}$	13 $\frac{3}{4}$	15	16	17 $\frac{1}{4}$	19 $\frac{1}{2}$	20 $\frac{3}{4}$	22	23	24	25	26 $\frac{1}{2}$	27 $\frac{1}{2}$	28 $\frac{3}{4}$
2 $\frac{1}{2}$ in.	15 $\frac{1}{2}$	17	18 $\frac{1}{2}$	20	21 $\frac{1}{2}$	23	26	28	29 $\frac{1}{2}$	31	32 $\frac{1}{2}$	34	35 $\frac{1}{2}$	37	39
2 $\frac{3}{4}$ in.	21	23	25	27	29 $\frac{1}{4}$	31	36	38	40	42	44	46	48	50	52 $\frac{1}{2}$
3 in.	27	30	32 $\frac{1}{4}$	35	38	41	46	49	52	54	57	60	62	65	67 $\frac{1}{2}$
3 $\frac{1}{4}$ in.	34	37 $\frac{1}{2}$	41	44	47 $\frac{1}{2}$	51	58	61	64	68	71	75	78	82	85
3 $\frac{1}{2}$ in.	43	47	52	56	60	64	73	78	82	86	90	95	99	103	108
3 $\frac{3}{4}$ in.	53	58	64	69	74	80	90	95	100	106	112	116	122	128	133
4 in.	64	70	77	83	90	96	109	115	122	128	134	141	148	154	160
4 $\frac{1}{4}$ in.	77	85	93	100	108	116	132	139	147	154	162	170	178	185	192
4 $\frac{1}{2}$ in.	90	99	108	117	126	135	153	162	171	180	189	198	207	216	225
4 $\frac{3}{4}$ in.	108	118	130	140	151	162	184	194	205	216	226	237	248	260	270
5 in.	125	138	150	162	175	188	200	212	225	235	262	275	288	300	313

Bearings next to main drives, rope, belt, or wheel, should be larger than given above.

Shafts under 3 in. dia. should not be used without extra support for driving mules of 1,000 spindles each.

Line shafts, as much as 150 ft. long, should be rather stronger than this list gives, at their driving end.

**POWER OF SHAFTING.** (11 ft. bays.)—Continued.  
SPEEDS.

Dia. of Shaft	POWERS																
	260	270	280	290	300	310	320	330	340	350	370	390	400				
2 in.																	
2½ in.	30	31	32½														
2¾ in.	40½	42	43½	45	46½												
3 in.	54½	56½	59	61	63	65	67	69	71	73							
3 in.	70	73	76	79	81	84	87	89	92	95	98	100					
3¼ in.	88	92	95	99	102	105	108	112	116	119	122	126	136				
3½ in.	112	116	120	124	129	134	138	142	146	150	155	160	172				
3¾ in.	138	143	149	154	160	164	170	175	180	186	191	196	212				
4 in.	166	173	180	186	192	199	205	210	217	225	230	237	256				
4¼ in.	200	208	216	224	232	240	246	255	262	270	278	286	309				
4½ in.	234	243	252	261	270	279	288	297	306	315	324	333	360				
4¾ in.	280	290	302	314	324	336	345	356	367	377	388	400	432				
5 in.	325	338	350	363	375	388	400	413	425	438	450	463	500				

Where powers are not given, shafts are unsuitable for the speed with 11 ft. bays.

Bearings next to main drives, rope, belt, or wheel, should be larger than given above.

Shafts under 3 in. dia. should not be used without extra support for driving mules of 1,000 spindles each.

Line shafts, as much as 150 ft. long, should be rather stronger than this list gives, at their driving end.

## ROPE DRIVING

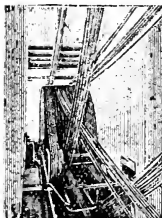

The most favoured system of transmitting power from the steam engine or other motor, to the various line shafts of a cotton mill, is that of rope-driving. Ropes are less costly than either gearing or belts; are clean, noiseless in operation, and occupy little space sideways. With a multiplicity of ropes there is little inconvenience from breakdowns, and repairs can be executed quickly.

In designing modern mills it is customary to divide a portion of the building off for what is called the "rope race." This extends from the engine house to the line shafts of each floor, and should be entirely isolated by strong walls. The fly-wheel of the engine constitutes the driving pulley; it is usually made with from 40 to 60 grooves, according to the power to be transmitted.

Transmission of power by ropes may be regarded as *positive*. Accordingly, in making calculations for speeds, no account need be taken of "creep" or "slip," as in the case of belt driving.

Sixpence per H.P. per annum, it is estimated, will amply cover all repairs to a first-class rope-driven plant, including rope renewals.

**FAST AND LOOSE ROPE PULLEYS.**—By a combination of fast and loose sheaves power may be transmitted from the line shaft to the machines of a cotton mill. The arrangement consists in providing a shallow intermediate groove in one side of the fast pulley in addition to the grooves ordinarily provided. In starting the machine and as the rope is transferred from the loose to the fast pulley, it passes into the shallow groove mentioned, and thus gains a revolution before entering upon its work. The system works very successfully in driving ring frames.

### HINTS TO USERS.

In designing a rope drive, take care to have the pulleys large enough, and to have a margin of rope power.

**Pulleys.**—These should not be less than 30 times the diameter of the rope used. Pulleys that are too small, quickly break up the ropes. Moreover, they reduce the power the ropes will transmit.

**Speeds.**—When the pulleys are reasonably large, 4,800 feet per minute is a good speed for ropes driving the

Powers that ropes will transmit under favourable conditions :—

ROPE SPEEDS IN FEET PER MINUTE.

Smallest Pulley	Diam. of Rope	2500	3500	4500	2700	3800	2900	3000	3100	3200	3300	3400	3500	3600	3700	3800	3900	4000	4100
33 in.	1 in.	8	8	9	9	9	10	10	10	11	11	11	12	12	12	13	13	13	13
42 in.	1 1/4 in.	13	13	14	14	14	15	15	16	16	17	17	18	18	19	19	20	20	21
48 in.	1 1/2 in.	19	19	20	20	21	22	22	23	24	25	25	26	27	28	28	29	30	31
57 in.	1 3/4 in.	25	26	27	27	28	29	30	31	32	33	34	35	36	37	38	39	40	41

HORSE POWERS.\*

ROPE SPEEDS IN FEET PER MINUTE.

Smallest Pulley	Diam. of Rope	4200	4300	4400	4500	4600	4700	4800	4900	5000	5100	5200	5300	5400	5500	5600	5700
33 in.	1 in.	14	14	14	15	15	15	16	16	16	17	17	17	18	18	18	19
42 in.	1 1/4 in.	21	22	22	23	23	24	25	25	26	26	27	27	28	28	29	30
48 in.	1 1/2 in.	31	32	33	34	34	35	36	37	37	38	39	39	40	41	42	43
57 in.	1 3/4 in.	42	43	44	45	46	47	48	49	50	51	52	53	54	55	56	57

HORSE POWERS.\*

\* These powers are based on the assumption that one or both of the rope pulleys are as small in diam. as those shown in the first columns of the above Tables. If the smallest pulley used is larger than these sizes, then the power given in the list corresponding to the diam. of the rope and the rope speed should be increased in proportion. That is, take the power from the Table, multiply it by the diam. in inches of the smallest pulley actually used, and divide by the diam. in inches of the pulley given above.

EXAMPLE;—1 1/2 in. rope running 4,500, smallest pulley 48 in., power  $\frac{34 \times 56}{34 \times 56} = 40$  horse power nearly.

1 1/2 in.

line shafts of a cotton mill. Speeds above 5,000 are not economical, as far as the durability of the ropes is concerned.

**Grooves.**—For ropes exceeding 1 in. dia., the grooves should have an angle of 40 degrees, and for smaller ropes, 30 degrees.

**Carrier Pulleys.**—The grooves should allow the rope to rest well in the bottom, and have flanges at an angle of about 10 degrees.

**Cross Driving.**—Arrange the ropes in pairs, crossing one rope to the left hand, the other to the right hand, so that the tight sides of both run next to each other. Between each pair of ropes there should be a spare groove in the pulleys. The pulleys should be as near as possible of the same diameter. If one is much larger than the other, the crossing occurs nearest the small pulley, and the ropes are then liable to chafe against each other.

**Drive Out of Parallel.**—The grooves should be of such depth as to measure from  $1\frac{1}{2}$  to 2 in. diameter at the opening.

**Angular Drive, with Guide Pulleys.**—The tight side of the ropes should be guided to its position by the pulley resting at an angle, while the pulley having the horizontal axis guides the trailing span. This rule holds good whether the pulleys are on the same plane or above or below each other.

**Vertical Driving.**—Allow a little extra for power, and do not have the grooves at an angle of more than 30 degrees.

**Vertical Half-Cross.**—Have the centres as far apart as possible, and plenty of room for adjusting the pulleys on the shafts.

**Slipping** of the ropes may arise from the following causes:—(1) Insufficient gripping force on the pulley. (2) Overloaded drives. (3) Slack ropes.

**Points:—**

Ropes diminish slightly in diameter with wear, and when new should exceed by  $\frac{1}{8}$  inch the groove they are actually made for.

Ropes run best if treated occasionally with a little anti-fraying composition.

Never put water on ropes to tighten them: its effect is only temporary, and the rope eventually stretches worse than ever.

To Ascertain the Length of a Rope.—Centre to Centre of shaft  $\times 2 +$  half circumference of each pulley.



**Metallic Rope Coupling.**—For use in place of hand-splicing in connecting the ends of driving ropes. Is constructed on the cup-and-ball principle, with two screwed parts carrying nuts over which the ends of the rope are passed. Two collars close in upon the loose portion of the rope. To prevent the metal portion of the coupling from coming into contact with the grooves of the rope pulley, the joint is surrounded with a thin covering, which is stitched in its place. When taking up "slack" in the rope, it is only necessary to disconnect the coupling, twist the rope to the required tension, and reconnect the parts.

## BELT DRIVING

Belt or Strap Driving, whether by means of leather belts or woven or other materials, is a convenient method of transmitting power.

It is almost universally employed in the case of driving each separate machine in textile and other factories, because of the great convenience of using fast and loose pulleys, by means of which each machine can be stopped or set in motion while the driving shaft is running.

A belt transmits its motion entirely by frictional contact with the surface of the driving and driven pulley.

There is always more or less slip, which must be allowed for—say 3 per cent. for leather and  $1\frac{1}{2}$  per cent. for woven belts.

Increase of power can always be obtained by increasing the size of the pulleys, which gives a larger frictional area. Where possible the sag of the strap ought always to be on the top side, so as to increase the area of the lap and give a larger and tighter grip.

Under the best conditions, with sufficient frictional area and belts of suitable width and strength, 75 per cent. of the power delivered by the driving pulley is transmitted to the driven pulley.

The coefficient of friction between cast-iron pulleys or drums with leather belts is about 0.45 when the belt is tight on the pulley. The friction is greater on wood pulleys, as also on pulleys lagged on the surface or covered with paper or other material.

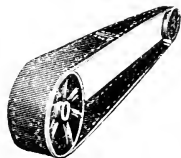

The power that can be transmitted by a belt depends on the thickness and width of the belt, the size of the pulley, and the speed at which the belt travels. The maximum strength of good leather is about 3,500 lb. per square inch of section.

There is no advantage in running belts above 4,000 feet per minute, as the centrifugal force then becomes excessive.

The speed of a strap per minute can always be found by multiplying the circumference of the pulley on which it works (in feet) by the speed or revolutions of the shaft per minute. If the pulley is small, the circumference in inches may be multiplied by the revolutions per minute, and then divided by 12 to give the feet.

The thickness of leather belts is usually from  $\frac{3}{16}$  to  $\frac{1}{4}$  inch, but compound belts may be made of as many thicknesses as required.

Woven belts of cotton or other fibres can be made of any width or thickness required. Leather belts also are formed by linking pieces of leather together by steel rods; they have great flexibility and yield good results, but when first used the initial stretching is considerable. Leather belts must not be used in damp places. Woven belts have the advantage of being made of any length and width in one piece, and can now be obtained of much greater strength than leather belts of the same thickness, and can be made so as to be unaffected by water, steam, chemical fumes, etc.

In making out calculations of speeds, etc., when driving by belting, allow from 1 to 2 per cent. for loss in "creep" or "slip."

**Rules.**—To find the horse-power any given belt will transmit—

Multiply the width of the belt in inches by 45 if single belt and by 75 if double; then by the speed of the belt in feet per minute; next divide by 33,000, and this will give the horse-power.

*Example.*—What power will a single belt 10 inches wide and running at 1,200 feet per minute drive?

$$\frac{10 \times 45 \times 1,200}{33,000} = 16.36 \text{ H.P.}$$

For double belting—

$$\frac{10 \times 75 \times 1,200}{33,000} = 27.27 \text{ H.P.}$$

To find the width of belt necessary to drive any given horse-power—

Multiply the power to be driven by 33,000, and divide by 45 for single belt and 75 for double belt, multiplied by the speed of the belt in feet per minute. This will give the width of belt in inches.

*Example.*—What width of belt is necessary to drive 50 horse-power when the belt runs at 2,200 feet per minute?

$$\frac{50 \times 33,000}{45 \times 2,200} = 16.6 \text{ inches for Single Belt.}$$

$$\frac{50 \times 33,000}{75 \times 2,200} = 10 \text{ inches for Double Belt.}$$

**Pulleys.**—For belt-driving it is advisable to use as large pulleys as convenient and the nearer the ratio between the driver and the driven pulley the better. Belts on large pulleys have a greater efficiency than on small ones; on narrower ones (consistent with necessary strength) than on wider ones; and on long drives than on short ones.

Where clutches are not employed on the pulleys of line shafts, it is better to use mounters for getting the belts on the pulleys than to do the work by hand. Appliances are now made with the upper portion flexible, so that the mounter follows the belt round the pulley, until it releases itself and can be removed without danger to the operator.

**Belts** ought always to be of sufficient width and strength to transmit the power without straining. The rules above give these for any given power.

The use of good belt "dressing" will give better driving and keep the belts in good order so that they last longer.

F. H. B.

## ELECTRICAL DRIVING

The electric transmission of power by means of a dynamo and motors is the simplest form of distribution, because it does away with shafting and pulleys, ropes and straps.

A first-class electrical equipment will transmit 80 per cent. of the power generated by the dynamo.

Electrical distribution is most economical when the area covered by the works is large and the machines are far apart; likewise where the machines are not all fully employed at the same time.

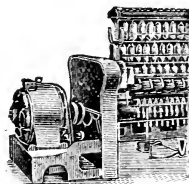

Wherever a unit of electricity (one "kilowatt") can be obtained at  $\frac{1}{4}$  of a penny or less it is the cheapest source of power. It can then be employed either for large or small mills, and saves the necessity for putting down separate power plant. When above  $\frac{1}{4}$ d. per kilowatt, it only has advantages in special cases for large plant.

An electrical horse-power is represented by a consumption of 746 watts per minute. If it was 750 watts it would equal  $\frac{3}{4}$  of a Board of Trade unit (1 kilowatt).

An Electric current Motor cannot be treated like a steam engine. Give the engine steam, and it will work; give it more steam, and it will work faster. The rating of an electric motor is to some extent an arbitrary matter. For instance, one rated at 10 H.P. might be too large for certain duties, and thereby work inefficiently; or too small for others, and in consequence over-heat, with risk of breakdown.

In electric driving it is necessary to insert a considerable "resistance" when starting-up a motor. This may be done by hand; but it is better to make use of some automatic arrangement, which is operated directly or indirectly by the load itself, and which causes the starting resistance to be cut off gradually. Appliances for this purpose are available. In some of these, the resistance is switched out by means of a centrifugal governor, connected by belt driving to the motor itself.

#### Advantages of electrical transmission:—

- (1) The prime mover and machinery may be placed in any relative position.
- (2) Each machine can be driven independently without reference to others, and where grouping is necessary, greater simplicity is possible, with less cost in regard to shafting.
- (3) Greater steadiness of driving and greater output of each machine.
- (4) Greater immunity from breakdown, less cost in running on light loads, ease in sectional working.
- (5) Where current is obtained from a central power-station, great reduction in capital outlay.
- (6) Continual check on the power consumed in the total, and in each department, is possible by use of recording instruments.

- (7) Greater simplicity and convenience, as power and light can be obtained off the same circuit.

**Distribution.**—There are two methods of electrical distribution:—

(A) CONTINUOUS CURRENT.

The continuous current dynamos and motors are simple in form and construction, of great reliability, and can be easily started even on full load. The speed can be varied easily and economically when required, without any mechanical devices.

Lighting can easily be taken from the same circuit as the power.

This system, however, requires heavier and more expensive cables, and there is more attention and expense with "sparking," and wear at the commutators.

It is the best and simplest form where the machinery is concentrated in a small space and the distance of transmission is not great. For direct-current power installations, 500 is a convenient voltage.

(B) ALTERNATING HIGH-TENSION CURRENT.

This system is suited for long-distance transmission, and the generators and motors have no commutators or brushes. Small and less costly cables can be used.

Although the motors are less reliable, they are simpler; and there is no difficulty (except a loss in efficiency) in using step-down transformers to reduce the voltage, and rotary converters to change the alternate into the direct current. Thus the dual system can be employed with advantage, and the difficulty of altering the speed of alternating motors is avoided.

A three-phase system, with 40 to 50 alternations per second and 500 volts, is found very suitable for a power installation, and induction motors can be used without changing the alternating into a direct current.

For long distance transmission 10,000 volts or even more may be employed, with step-down transformers at the works

---

Whichever system be employed, it is not always economical to drive each machine with a separate motor,

as capital expenditure is greater and efficiency less, especially where small power is required.

In engineering works, and in bleaching, dyeing, printing, and finishing works, separate motors will probably give the best results, and as variations in speed are constantly required, direct-current motors will be found most suitable.

To drive all the machines in a mill by separate or individual motors is not likely to be a practical success. The individual system is only worked with advantage in driving openers and scutchers, and ring spinning and doubling frames. The card and spinning rooms (when the latter contain self-acting mules) are best driven from line-shafts, with separate motors for each shaft. In this way considerable space is saved by dispensing with the rope-race; and, as there is no limit to the facilities afforded for subdividing the distribution of power in the rooms, counter-shafts can be arranged at suitable places, where a line-shaft would more than suffice.

In applying the power to ring frames engaged in spinning yarn of different counts, it is a common practice to employ motors larger than are absolutely required, in order to attain the variations in the speeds necessitated by these changes. A better way to accomplish this is to drive the tin-roller shaft through gearing, instead of coupling the motor up direct to the shaft. One of the wheels employed can be used as a change pinion, and the speeds be thereby altered at will.

By adopting electricity as the motive power for driving cotton machinery, it is claimed that a greater production can be got from the machines. This increase in production is primarily due to the steadiness of the driving. With the machines running at the same speed, and containing the same number of spindles, the breakages, when machines are driven electrically, are found in practice to be considerably fewer than when driving by any other means.

It is further found that, owing to the steadiness of the drive, the speed of the machines can be increased, and, as a result, greater production obtained. Hence there is not only an advantage to the millowner, but also to the operatives, who find their earnings are increased.

**Cost.**—The following may be taken as an approximate estimate for two plants of 1,000 I.H.P., one with rope drive and the other electrically driven:—

#### ROPE-DRIVEN PLANT.

Two 500 I.H.P. engines and boilers, economisers, superheaters, and all accessories up to fly-wheel shaft.....	£10,000
Ropes, rope pulleys, and all shafting, with necessary pulleys .....	£5,000
Total ...	£15,000

#### ELECTRICALLY-DRIVEN PLANT.

(Three-phase alternating current and induction motors.)

Steam plant, 1,200 B.H.P., with high-speed engines, boilers, superheaters, separate condensing plant, and all accessories.....	£10,000
1,100 k.w. alternating fly-wheel generator, with accessories and switch-board, etc.....	£3,000
Line shafts and pulleys .....	£2,000
Four 150 H.P. alternating induction motors and five smaller ones, with wiring, resistances, switch-boards, cut-outs, etc. ....	£5,000

Total ... £20,000

Thus the electrical driving for the same effective horse-power in the factory would be 33 per cent. more than the direct rope-drive, and the running expenses probably 10 per cent. more.

If, however, the current could be purchased from a central power station, thus dispensing with the electrical generating plant, so that only motors need be installed, the position would be reversed, for the cost of electrical equipment would only be £10,000, as against £15,000 for the rope-drive—or a saving in capital expenditure of 33 per cent. And with a current at  $\frac{1}{4}$ d. per unit or less, the cost per effective horse-power per annum would not exceed £2 5s.—including everything.

#### Electric Driving of a Weaving Shed.

The following particulars give the Brake Horse Power consumed in driving a weaving shed. They have been arrived at as the result of a careful test made by Mr. J. M. Hewitt, consulting engineer, of Manchester. The test was carried out under ordinary working conditions, at a new weaving mill driven as well as lighted by electricity.

The shed contained 1,620 looms, driven in the ordinary way by line shafting and belts. To the end of each line shaft a 25 B.H.P. three-phase motor was coupled by means of spur and pinion. The motors were fixed on the wall by special brackets, to leave all available floor space for the looms.

The power was obtained from an enclosed vertical triple-expansion high-speed engine, which was coupled direct to a three-phase dynamo. Steam was generated by two mechanically fired 30 ft. × 8 ft. Lancashire boilers, at a pressure of 170 lb., and passed on its way to the engine through a separately (coke) fired superheater.

The feed water was taken from the condenser, and was passed through an economiser to the boilers by means of a Weir type of pump. A jet condenser was used, and the two-throw Edwards air pump was driven by a motor.

Average temperature of feed water to economiser .....	84 deg. F.
Average temperature of feed water to boilers..	235 deg. F.
Average temperature of steam to engine.....	480 deg. F.
Average temperature of superheated at engine	109 deg. F.
Steam pressure at boilers .....	170 lb.
Steam pressure at engine .....	140 lb.
Vacuum at engine .....	24.7 in.
Average indicated horse power .....	857
Steam per indicated horse power .....	13.5 lb.
Coal                   "                   " .....	1.41 lb.
Coke                   "                   " .....	.16 lb.
Total fuel           "                   " .....	1.57 lb.
Water evaporated per lb. of Lancashire slack	9.57 lb.
Average I.H.P. driving all mill motors, shafting, and condenser motor .....	185.5
Average brake horse power to looms .....	580
Looms per brake horse power exclusive of all losses in motors, transmission, shafting, and belting .....	2.8
Motor efficiency .....	86 per cent.
Transmission efficiency .....	97 per cent.

NOTE.—The high-pressure piston rings of the engine were leaking badly, causing the coal consumption per I.H.P. to be much higher than it had been in previous tests.

Mr. Hewitt, in commenting upon the figures, says:—

"It will be noticed from the foregoing figures that the evaporation of 9.57 lb. of water per lb. of Lancashire slack is very satisfactory.



“The fuel per I.H.P. is not at all excessive, but a former test gave 11 lb. of steam per B.H.P. = 1.15 lb. of Lancashire slack per B.H.P.

“The losses in transmission seem fairly large, but, to a great extent, they are due to the loom belts, and are unavoidable in either mechanical or electric driving.”

**Driving Power for Mills.**—A ready way of ascertaining approximately the power required to drive a cotton spinning mill complete is to take the following predetermined numbers as a basis for calculation:—

30 for a mule mill and 20 for a ring mill.

Either of these numbers + the counts spun ÷ total number of spindles in mill = approx. horse power. Thus, for a ring mill containing 50,000 spindles, spinning 30's counts, the result would be—

$$\frac{50,000}{20 + 30} = 1,000 \text{ Horse Power.}$$

#### Memoranda for Electrical Installation.

1 Watt = 1 Ampere quantity at 1 volt pressure.

1,000 Watts { = 1 Board of Trade Unit (B.T.U.)  
per hour. { = 1 Kilowatt hour (or K.W.H.)

1 Electrical horse-power = 746 watts.  
= approximately  $\frac{3}{4}$  B.T.U.

Volts × Amperes ÷ 746 = 1 E.H.P.

Watts × 1.34 = 1 E.H.P.

1 Brake horse-power = 1 large 2,000 c.p. arc lamp, or 10 16-c.p. glow lamps, or 20 8-c.p. glow lamps.

## FENCING OF MACHINERY AND MILL GEARING

(From “The Factory and Workshop Act, 1901,” by J. W. Carter. Blackburn: “Times” Printing Works. 1s.)

Section 10 imposes an absolute obligation on the occupier of a Factory to securely fence every hoist or teagle, and every fly-wheel directly connected with the steam or water or other mechanical power, whether in the engine-house or not, and every part of any water-wheel or engine worked by any such power, and as to every wheel-race not otherwise secured, to securely fence it close to its edge.

(Continued on p. 374.)

DETAILS OF MILL STRUCTURAL WORK.

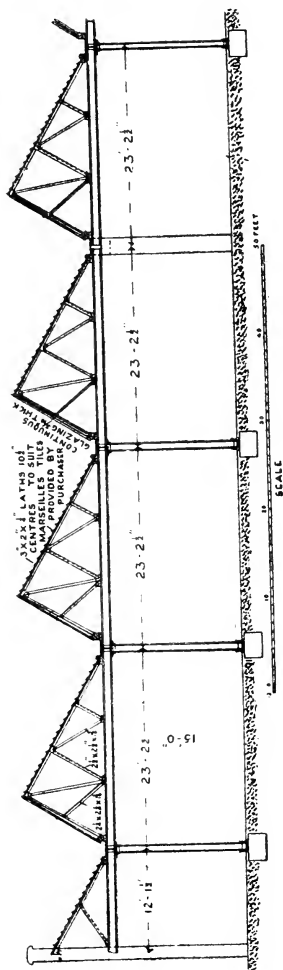

DETAILS OF ROOF FOR A SHED BUILDING.

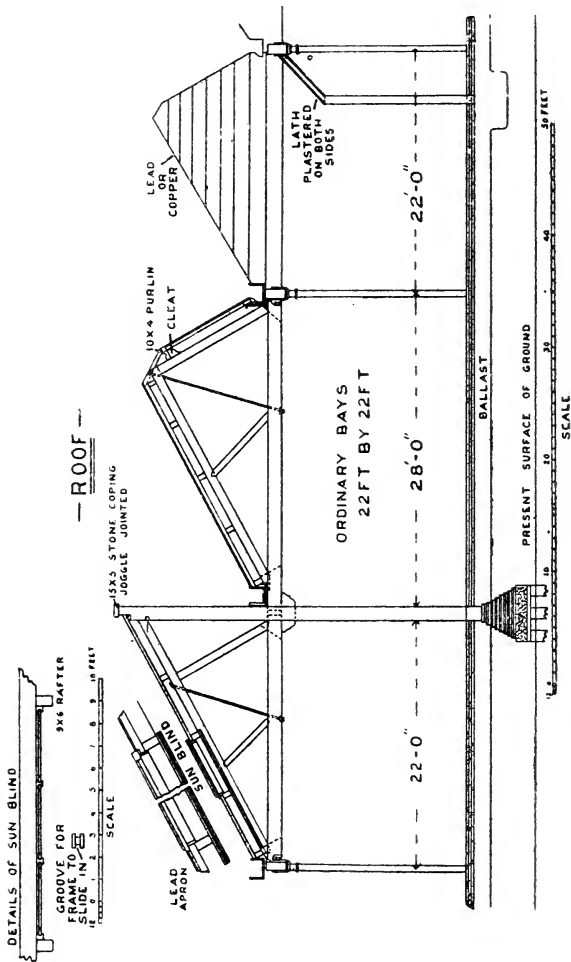

DETAILS OF ROOF FOR A SHED BUILDING.

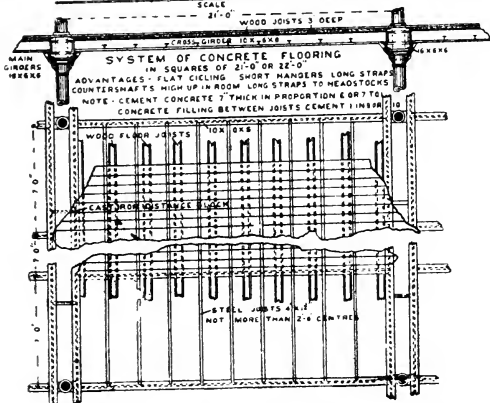
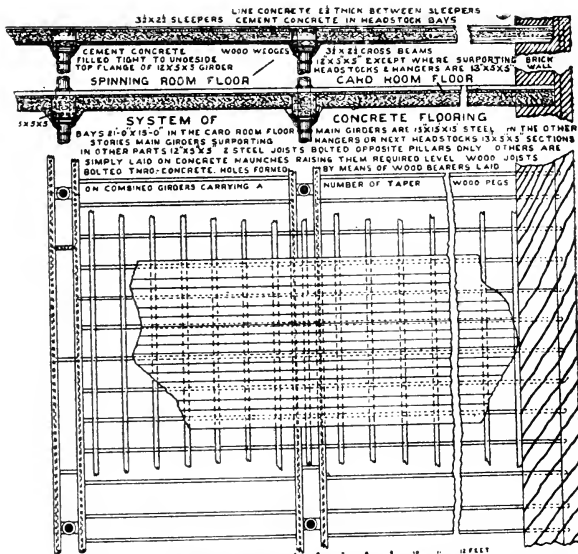

SYSTEM OF CONCRETE FLOORING FOR COTTON SPINNING MILL.

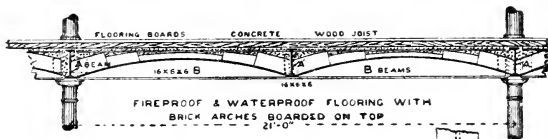

FIREPROOF & WATERPROOF FLOORING WITH BRICK ARCHES BOARDED ON TOP

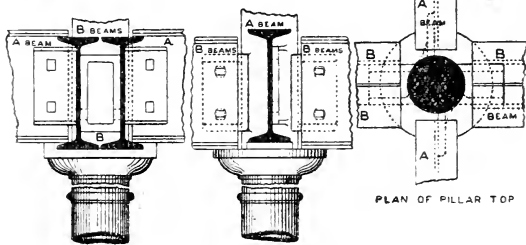

DETAILS OF PILLARS

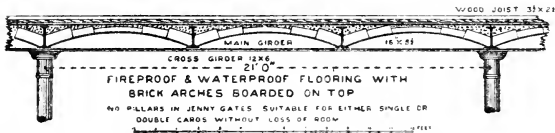

FIREPROOF & WATERPROOF FLOORING WITH BRICK ARCHES BOARDED ON TOP

NO PILLARS IN JENNY GATES SUITABLE FOR EITHER SINGLE OR DOUBLE CARDS WITHOUT LOSS OF ROOM

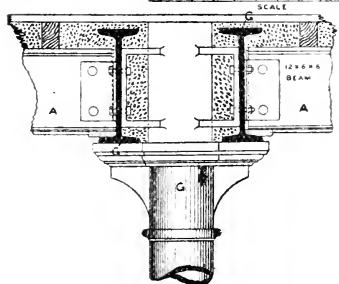

DETAIL SHOWING CONNECTION OF 2-16x5 1/2 BEAMS ON PILLAR TOP

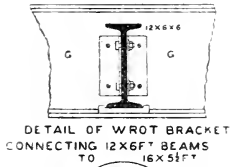

DETAIL OF WROUGHT BRACKET CONNECTING 12x6 FT BEAMS TO 16x5 1/2 FT

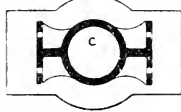

PLAN OF PILLAR TOP

SECTIONS OF FIREPROOF AND WATERPROOF FLOORING, WITH BRICK ARCHES AND BOARDED TOP, FOR COTTON SPINNING MILL.

(Concluded from p. 369.)

The Section also requires that all dangerous parts of the machinery and every part of the Mill gearing shall either be securely fenced or be in such position or of such construction as to be equally safe to every person employed or working in the Factory as it would be if it were securely fenced.

#### DEFINITIONS OF MILL GEARING AND MACHINERY.

The expression "Mill gearing," as used in the Act, comprehends every shaft, whether upright, oblique, or horizontal, and every wheel, drum or pulley or other appliance by which the motion of the first moving power is communicated to any machine appertaining to a manufacturing process; and "Machinery" includes any driving strap or band. (Section 156.)

The question of what is dangerous machinery is one of fact to be determined in each case. In *Hindle v. Birtwistle* (1897) 1. Q.B., 192, it was held that the enactment applies to all machinery from which in the ordinary course of working it, danger may reasonably be anticipated, although such danger may arise by reason only of careless working or of external causes.

#### SPECIAL REGULATIONS AS TO MULES.

Certain parts of self-acting mules must now be fenced. The Secretary of State, in pursuance of powers conferred on him by Section 79, has certified self-acting mules to be dangerous to life and limb, and made certain regulations which he directs shall apply to a Factory in which self-acting mules are used for spinning. One of these regulations (paragraph 3) is as follows:—

After January 1, 1906, the following parts of every self-acting mule shall be securely fenced so far as is reasonably practicable, unless it can be shown that by their position or construction they are equally safe to every person employed as they would be if securely fenced:—

- (a) Back shaft scrolls and carrier pulleys and draw-band pulleys.
- (b) Front and back carriage wheels.
- (c) Faller stops.
- (d) Quadrant pinions.
- (e) Back of head-stocks, including rim-pulleys and taking-in scrolls.
- (f) Rim band tightening pulleys, other than plate wheels, connected with a self-acting mule erected after January 1st, 1906.

SECTION XI:

ASSOCIATIONS

OF

EMPLOYERS AND OPERATIVES



HOLIDAYS

IN THE COTTON DISTRICTS

## ASSOCIATIONS AND SOCIETIES

(Other than Trade-Unions)

## CONNECTED WITH THE COTTON TRADE

- Accrington and District Master Cotton Spinners and Manufacturers' Association**, 12, Darwen Street, Blackburn.—John Taylor, Secretary.
- Ashton and District Cotton Employers' Association**, 3, Market Avenue, Ashton-under-Lyne. G. W. Fielding, Secretary.
- Blackburn and District Master Cotton Spinners and Manufacturers' Association**, 12, Darwen Street, Blackburn.—John Taylor, Secretary.
- Blackburn and District Managers' Mutual Association**.—Thos. Hurrell, 1, Stephen Road, Blackburn.
- Bolton and District Master Cotton Spinners' Association**, 23, Acresfield, Bolton.—A. Hill, Secretary.
- Bolton and District Managers and Overlookers' Association**, The Institute, Henry Street, Bolton.—Joseph Parkinson, Secretary, 369, Bridgeman Street, Bolton. Fortnightly Meetings, Saturdays.
- Bolton and District Managers, Carders, and Overlookers' Association**.—T. Hampson, Secretary, 16, Thorpe Street, Bolton. Meetings at Woolpack, Deansgate. Also branch at Old Boar's Head Hotel, Bury.
- Bolton and District Cotton Manufacturers' Association**, 23, Acresfield, Bolton.—Herbert Fray and John Taylor, Joint Secretaries.
- Bolton Quilt Manufacturers' Association** (Joseph R. Vose, F.C.I.S., sec.), 11, Chancery Lane.
- British Association of Managers of Textile Works**, 27, Brazenose Street, Manchester.—Wm. Bleakley, President; Robert Livesey and Wm. Boothman, Vice-Presidents; and H. Julius Lunt, Secretary. Meetings at the Victoria Hotel, Manchester. Saturdays.
- British Association of Managers of Textile Works (Yorkshire Section)**, Halifax Commercial Bank Chambers, Tyrrel Street, Bradford.—John Wade, Chairman; T. Town, Vice-Chairman; A. Greenlay, Secretary. Meetings, Technical College, Bradford. First Thursday in each month at 8 p.m.
- British Cotton-Growing Association**, 15, Cross Street, Manchester.—J. A. Hutton, Chairman; E. H. Oldfield, Secretary.
- Burnley Master Cotton Spinners and Manufacturers' Association**, 7, Grimshaw Street, Burnley.—F. A. Hargreaves, Secretary.
- Bury District Federation of Cotton Spinners and Manufacturers**, 11, Cedar Street, Bury.—E. C. Rostron, Secretary.
- Chorley Master Cotton Spinners' Association**.—Arthur Karfoot, Secretary, Park Villa, Chorley.
- Chorley Cotton Manufacturers' Association**, Chorley.—Arthur Karfoot, Secretary, Park Villa, Chorley.
- Colne and District Coloured Goods Manufacturers' Association**, 7, Grimshaw Street, Burnley.—F. A. Hargreaves, Secretary.
- Cotton Employers' Parliamentary Association**, 12, Exchange St., Manchester.—F. A. Hargreaves, Secretary.
- Cotton Waste Spinners and Manufacturers' Association**, 12, Exchange Street, Manchester.—F. A. Hargreaves, Secretary.
- Darwen Cotton Manufacturers' Association**, District Chambers, Darwen.—Thomas Hindle, Secretary.



- Darwen Cotton Employers' Association.**—J. Hollis, India Mills, Darwen.
- Extra Hard Cotton Twist Spinners' Association, Ltd.,** 4, Chapel Walks, Manchester.
- Farnworth Cotton Spinners' Association.**—C. Young, c/o Messrs. T. Barnes and Co., Ltd., Farnworth.
- Federation of Master Cotton Spinners' Associations,** 15, Cross Street, Manchester.—C. W. Macara, President; John Smethurst, Secretary.
- Glossop, Hyde, and District Cotton Employers' Association**—J. Hawkins, Broad Mills, Ltd., Broadbottom.
- Haslingden Cotton Manufacturers' Association,** Haslingden.—H. Warburton, Secretary, 323, Blackburn Road, Haslingden.
- Heywood and District Cotton Employers' Association,** W. E. Parker, 5, Hind Hill Street, Heywood.
- Heywood and District Manufacturers' Association,** 5, Hind Hill Street, Heywood.—W. E. Parker, Secretary.
- International Federation of Master Cotton Spinners' and Manufacturers' Associations,** 15, Cross Street, Manchester.—C. W. Macara (England), President; John Syz (Switzerland), Vice-Chairman; Arno Schmidt, Secretary; and John Smethurst, Hon. Secretary.
- Liverpool Cotton Association, Ltd.,** Brown's Buildings, Liverpool.—Edward Comber, President; John G. Dobson, Vice-President; John R. Kewley, Treasurer; George F. Higgins, Secretary; H. Stuart Hanmer, Assistant Secretary; and H. Lloyd Jones, Manager.
- Manchester and District Cotton Employers' Association.**—W. G. Wilson, 6, Poplar Road, Monton, Secretary.
- Manchester Association of Engineers,** 29, Brown Street, Manchester.—Frank Hazelton, Secretary.
- Manchester Cotton Association, Ltd.,** 22, St. Mary's Gate, Manchester.—Percy Dews, President; J. K. Bythell, Vice-President; and Chas. Mayall, Secretary. Telephone 2830 City. Telegrams, "Arrivals, Manchester."
- Manchester and District Engineering Trades Employers' Association,** Tower Chambers, 30, Spring Gardens, Manchester.—Frank Hazelton, Secretary. T.N.: 3786.
- Manchester Home Trade Association** (N. Spencer, sec.), 15, High Street.
- Nelson and District Manufacturers' Association,** 7, Grimshaw Street, Burnley.—F. A. Hargreaves, Secretary.
- North and North-East Lancashire Cotton Spinners and Manufacturers' Association,** 12, Exchange Street, Manchester.—John Taylor, 12, Darwen Street, Blackburn, and F. A. Hargreaves, F.C.A., 7, Grimshaw Street, Burnley, Joint Secs.
- North Lancashire Master Cotton Spinners and Manufacturers' Association,** 53, Lune Street, Preston.—J. Ward, Secretary.
- Oldham Mill Managers' Technical Association,** 6, Vulcan St., Oldham.
- Oldham Master Cotton Spinners' Association, Ltd.,** District Bank Chambers, 12, Yorkshire Street, Oldham.—Jno. B. Tattersall, Chairman; Harold Cliff, Secretary; and John Pogson, Assist. Secretary.
- Padiham Master Cotton Spinners and Manufacturers' Association,** 7, Grimshaw Street, Burnley.—F. A. Hargreaves, Sec.
- Preston and District Mill Managers' Association.**—Jas. Livingstone, The Academy, Delaware Road, Preston.

- Radcliffe Manufacturers' Association** (Geo. Hodgson, sec.), Dingle Hurst, Outwood Road.
- Ramsbottom and District Employers' Association**, Irwell View, Ramsbottom.—J. H. Schofield, Secretary
- Rawtinstal Cotton Spinners' Association**, 11, Cedar Street, Bury.—E. C. Rostron, Secretary.
- Rochdale and District Cotton Employers' Association**.—R. Stott, District Bank Chambers, Rochdale.
- Rochdale and District Master Cotton Spinners and Manufacturers' Association**, 7, Grimshaw Street, Burnley.—F. A. Hargreaves, Secretary.
- Society of Textile Industries and Cotton Spinners**, 22, Rock Street, Oldham.—Thos. Sampson, Secretary.
- Stockport and District Cotton Employers' Association**.—C. Tyler, 37, Greek Street, Stockport.
- Stockport Mill Managers' Association**, Stockport.
- Textile Institute**.—Geo. Moores, Hon. Sec., 12, Exchange Street, Manchester.

### "MUTUAL" COTTON CLASSES.

- ASHTON-UNDER-LYNE**.—Friday, at the Alexandra Road School.
- CROMPTON**.—Friday, Ibbotson's Rooms, Milnrow Road, Shaw.
- CHORLEY**.—
- BURY**.—Thursday, Co-operative Building, Market Street.
- BLACKBURN**.—Thursday.
- HEYWOOD**.—Monday, Heywood Technical School.
- HYDE**.—Tuesday, Offices of the Card and Blowing-Room Operatives' Association.
- MOSSLEY**.—Wednesday.
- MIDDLETON**.—Thursday, Labour Rooms, Old Hall Street.
- ROYTON**.—Monday, Dogford Mill, Dogford Road. Sec., W. H. Pegler, 40, Westbourne Street, Oldham.
- ROCHDALE**.—Tuesday.
- STALYBRIDGE**.—Tuesday.

## TEXTILE ASSOCIATIONS ABROAD

### INDIA.

- Upper India Chamber of Commerce (Cotton Section)**.—S. M. Johnson, Cawnpore.
- The Cotton Spinners' Association**, Bombay.
- Bombay Mill Owners' Association**.
- Bengal Chamber of Commerce**, Calcutta.—Wm. Haywood, Sec.

### UNITED STATES OF AMERICA.

- American Cotton Manufacturers' Association**, Charlotte, N.C.—S. B. Tanner, President.
- Farmers' Educational and Co-operative Union (Planters)**, Dallas, Texas.—Chas. S. Barrett, Atwater, Ga., President.
- Arkwright Club (Cotton Trade)**, Boston, Mass.—Edwd. Stanwood, Secretary, 201, Columbus Avenue, Boston.
- The National Association of Cotton Manufacturers**, Room 57, International Trust Building, 45, Milk Street, Boston, Mass. C. J. H. Woodbury, Sec.
- The National (Southern) Cotton Association**, Atlanta, Georgia.—Harvie Jordan, President.

**AUSTRIA.**

**Verein der Baumwollspinner Oesterreichs**, 32/34, Maria Theresienstrasse, Vienna. Arthur Kuffler, President; August Beyer and Hans Haebler, Vice-Presidents.

**Verein der Baumwollweber Oesterreichs**, Rudolfsplatz, 13a, Vienna, I.—Kaiserlicher Rat Ernst Ritter von Boschan; Kommerzialrat Dr. Ernst Marbach, Dr. O. von Bronneck, Sec.

**BELGIUM.**

**Association Cotonniere de Belgique**, Ghent.—Jean de Hempinne, President, rue Charles V.; J. Neve, rue de la Croix, Ghent, Secretary.

**Association Belge de Tissage**, Ghent.

**DENMARK.**

**Textilfabrikantforeningens**.—Harry Dessau.

**FRANCE.**

**Syndicat General de l'Industrie Cotonniere, Francaise**, 5, rue St. Fiacre, Paris.—F. Kuhwarth, Secretary.

**Association Cotonnier Coloniale**, Paris.—A. Esnault-Pelterie, President; C. Meunier, Secretary.

**Syndicat Cotonnier de l'Est**, Epinal (Vosges).—R. Laederich, Vice-President; D. Joubin, Secretary.

**Syndicat Normand de la Filature de Coton**.—G. Badin, Barentin (Seine Inferieure), President.

**Syndicat Normand du Tissage de Coton**, Rouen.—J. Gailliard, Barentin (Seine Inferieure).

**Syndicat des Filateurs et Retordeurs de Coton du Nord**, Lille (Nord).—Julien Le Blan fils.

**Syndicat des Filateurs de Coton de Roubaix-Tourcoing**.—L. Cavois.

**Syndicat de Roanne, Thizy et la Region**.—Stephane Faisant, Pres.

**Syndicat Cotonnier de Bolbec-Lillebonne**.—G. Lemaitre, Pres.

**Syndicat Picard des Industries Textiles**.—G. Sydenham, Rouvalles-Doullens (Somme), President; Roger Barbet-Massin, Amiens (Somme), Vice-President.

**GERMANY.**

**Industrie-Verein**, Werdau i. S.—Direktor Alfred Kahle, Leubnitz-Werdau, President.

**Kolonial-Wirtschaftliches Komitee**, Berlin.—Karl Supf, Unter den Linden 43, Berlin, President (Member of the Colonial Council); Moritz Schantz, Chemnitz.

**Verein Sueddeutscher Baumwoll-Industrieller**, Augsburg.—Kommerzienrat Heinrich Semlinger, President; Dr. E. Buettner, Secretary.

**Vereinigung Sachsischer Spinnerei-Besitzer, j.P.**, Chemnitz.—Kommerzienrat Emil Stark, President.

**Verband Rheinisch-Westphalischer Baumwollspinner**, M.-Gladbach.—C. O. Langen, President.

**Elsassisches Industrielles Syndicat**, Mulhausen (Alsace).—Geh. Kommerzienrat Schlumberger, Rene Kullman in Firma Kullmann und Cie.

**HOLLAND.**

**Nederlandsche Patroonsvereniging van Katoenspinners en wevers**, Enschede.—R. A. de Monchy, jr., Hengelo, Sec.

## ITALY.

- Associazione fra gli Industriali Cotonieri e Borsa-Cotoni**, 41, Via A. Manzoni, Milan.—Baron Costanzo Cantoni, Via Brera 12, President; Giorgio Mylius, Montebello 22, Vice-President.  
**Societa per la Coltivazione del Cotone nella Colonia Eritrea**.—Baron C. Cantoni, Via Brera 12, Milan.

## NORWAY.

- De norske Tekstilfabrikanter Forening**, Christiania.—N. Chr. Nielsen, Christiania.

## PORTUGAL.

- Associacao Industrial Portugueza**, Lisbon.—H. P. Taveira, 236, rua da Palma.  
**Associacao Industrial Portuense, Oport**.—Jacinto Magalhaes, 36, rua da Saudade, Oporto.

## RUSSIA.

- Cotton Committee of the Moscow Exchange**, Mjassnizkaja, Dom Kuznowa, Moscow.—R. von der Muhlen, Secretary.

## SPAIN.

- Fomento del Trabajo Nacional**, Barcelona.—J. Aguilera, Valencia 250, Barcelona, Secretary.  
**Sociedad de Fomento Fabril**, Santiago.

## SWEDEN.

- Svenska Bomulls Fabrikant-foreningen et Sveriges Textilindustri-forbund**, Stockholm.—Knut J. Mark, Gothenburg, President.

## SWITZERLAND.

- Schweizer Spinner-, Zwirner- und Weber-Verein**, Zurich.—John Syz, President; Eugen Egli, 9, Zeltweg, Zurich, Secretary.

## JAPAN.

- Japan Cotton Spinners' Association**, Go-chome, Fushimi-machi, Higashi-ku, Osaka.—Takeo Yamanobe, President; O. Shoji, Secretary.

---

## THE AMALGAMATED ASSOCIATION OF OPERATIVE COTTON SPINNERS

### DISTRICTS AND SECRETARIES.

---

- Accrington and District**—Black Horse Hotel, Abbey St.—1st Wed. in Jan, April, July, Oct.—Jas. Dewhurst, 10, Elephant St.  
**Ashton-under-Lyne Spinners**—Spinners' Offices, Old St.—3rd Thurs in March, June, Sept, Dec, at 7-30.—E. Judson, 116, Burlington Street.  
**Ashton Twiners**—Star Inn, Cotton St.—3rd Wed in Jan, April, July, Oct.—James Clayton, 32, Old Cross St.  
**Atherton**—Bear's Paw Hotel—2nd Wed in each month—John Ainscough, 91, Bolton Rd.  
**Bamber Bridge**—White Bull Inn—2nd Mon in March, June, Sept, Dec., and Mon after Rep. Mtg.—Thomas De Rome, 52, Station Rd.

- Blackburn**—Spinners' Institute, 9, St. Peter St.—2nd Thurs in month—James Johnson, 66 Copy Nook.
- Bollington Fine Spinners**—Bollington Sunday School—Wed before Quar. Rep. Mtg.—Henry Hardy, Lord St.
- Bolton**—77 St. George's Rd.—2nd Wed in each month—A. H. Gill, 61 Hampden St.
- Bradford**—Trades Hall, 2nd Fri in Jan, April, July, Oct.—Geo. E. Greenwood, 35, Hartington Terr., Lidget Green.
- Brighouse**—Oddfellows' Hall—2nd Sat in Jan, April, July, Oct.—H. Smith, Charles St., Lane Head.
- Burnley**—9, Bank Parade—Thurs before Quarterly Meeting—Henry Chisnall, 23, Bar St.
- Bury and District**—Textile Operatives' Hall—1st Thurs after 21st of month—A. E. Lees, 3, Mostyn St.
- Chadderton**—Unicorn Inn, Werneth—Wed following 2nd Tues in each month—J. Hilton, 199, Denton Lane, Hollinwood.
- Chorley**—28, High St.—Tues before 2nd Sat in March, June, Sept, Dec—Secretaryship vacant.
- Coldhurst**—Willow Bank Hotel—2nd Wed after 1st Tues—R. Weston, 12, Caroline St., Oldham.
- Darwen**—Spinners' Institute, 7-8, Crown St.—2nd Thurs in March, June, Sept, and Dec.—T. O'Neill, 2, Lightbowne St.
- Droylsden**—Cotton Tree Inn—2nd Mon in Jan, April, July, Oct.—Thomas Bertenshaw, 6, Duke St.
- Elland**—Temperance Schoolroom—2nd Sat in Jan, April, July, Oct.—W. Shaw, 23, Middle Dean St., Halifax.
- Failsworth**—Secular Hall, Poll Lane—2nd Tues in each month—F. Berry, 6, Robert St.
- Farnworth**—Market Hotel, Brackley St.—Tues before 2nd Wed in each month—Wm. Taylor, 100 Campbell St., Moses Gate.
- Gregson Lane**—Castle Hotel—1st Mon after Rep. Mtg.—John Almond, 17 Bridge St., Higher Walton, Preston.
- Halifax**—Friendly and Trades Club—2nd Sat in Jan, April, July, Oct.—W. Freeman, Great Albion St.
- Haslingden**—Victoria Hotel—3rd Thurs in March, June, Sept, Dec.—J. G. Lord, 46, Manchester Rd.
- Heywood**—Trades Hall—1st Wed after 2nd Tues in each month—James Turner, 42 Grosvenor St.
- Higginshaw**—United Methodist Schoolroom, Halstead St—1st Wed after 2nd Tues in month—E. Birch, 383, Shaw Rd, Oldham.
- Hindley**—Dog and Partridge, Atherton Rd.—2nd Thurs in March, June, Sept, Dec.—J. Grime, 730, Atherton Rd, Hindley Green.
- Hollinwood**—Congregational School, Pump St.—2nd Tues evening in the month—Walter Brierley, 14, Bourne St.
- Huddersfield**—Friendly and Trade Societies' Club, Northumberland St—1st Wed in month, 7-30—G. A. Hurst, 41, Northgate.
- Hyde**—Spinners' Institute, 29 George St—4th week in Jan, April, July, Oct—Arthur Williamson, 29, George St
- Kirkham**—Derby Arms Hotel—Mon before 1st Thurs in month—J. Kirley, 4, Garstang Rd. North, Wesham.
- Lancaster**—New Trades Hall, Queen's Square—3rd Thurs in March, June, Sept, Dec.—W. Gardner, 36, Victoria Terrace.
- Lees (near Oldham)**—Angel Inn—1st Wed after 2nd Tues in each month—R. Ashton, 19, Rhodes Hill, Lees.
- Leigh**—Bull's Head Hotel—2nd Mon in March, June, Sept, Dec.—John Cocker, 22, Oak Street.

- Macclesfield**—Franklin Inn, Steeple St.—1st Wed. in Jan, April, July, Oct.—L. Hough, 15, York St., Buxton Rd.
- Manchester**—Crown Inn, Mill St., Ancoats—Friday before 2nd Sat in March, June, Sept, Dec.—John Cadman, 9, Burnley St., Boundary St., Bradford Rd.
- Middleton**—Bricklayers' Arms, Market Place—2nd Tues in each month—Benjamin Dyson, 153, Rochdale Rd.
- Middleton Junction**—Gardeners' Arms, Middleton Junc.—2nd Tues in each month—Harry Matts, 15, Church Rd., Greenhill Rd.
- Mossley**—George Hotel—1st Wed in every month—Wright Mosley, 39, Arundel St.
- Oldham No. 1**—Spinners' Offices, Rock St.—Wed after 2nd Tues in each month—Thomas Hles, 109, Rock St.
- Oldham No. 2**—Duke of Edinburgh Hotel, King St—2nd Wed after 1st Tues. in each month—J. Bracewell, 15, Eldon St.
- Oldham Twiners**—Spinners' Offices, Rock St.—1st Wed after 2nd Tues every month—J. W. Jones, 139, Old Lane, Hollinwood.
- Oldham Executive Council**—Spinners' Offices, Rock St.—1st Tues in each month, 7-30—T. Ashton, 39, Belmont St., Frankhill.
- Oldham Roller Coverers**—Royal George Hotel, Rochdale Rd.—2nd Friday in each month—Thomas Mills, 1, Wye St.
- Padiham**—White Horse—2nd Thurs in each Quarter, 7-30—Robt. Bispham, 27, High St.
- Pendlebury**—New Cross Inn, Swinton Hall Rd.—2nd Wed in Jan, March, April, June, July, Sept, Oct, Dec.—J. Ford, 84 Moss Lane, Swinton.
- Preston**—Spinners' Institute, Church St.—1st Thurs in every month—James Billington, Prospect House, Long Lane.
- Rawtenstall**—Assembly Rooms, Cloughfold—Last Friday of Jan, April, July, Oct.—James Wright, 55, Bank St.
- Reddish**—Houldsworth Working Men's Club—Quarterly—Wm. Eckersley, 16, Hurst St.
- Ripponden**—Chartist Room—2nd Sat in Jan, April, July, Oct—J. Dyson, 111, Bankfield.
- Rochdale**—Spinners' Institute, King St—1st Tues in month, 7-30. Quar. Mtgs.; 2nd Tues in March, June, Sept, Dec.—Charles Redfern, 85, Hamer Lane.
- Royton**—Village School, Chapel Lane—2nd Tues in month—Robt. Barlow, 33, Queen St.
- Shaw and Crompton**—Oddfellows' Social Institute, Farrow St.—1st Wed after 2nd Tues in each month—Jos Sucksmith, 102, Manchester Rd., Shaw.
- Sowerby Bridge**—Cotton Operatives' Office—2nd Fri in Jan, April, July, Oct.—Arthur Gledhill, Dale Terrace.
- Stainland**—Holywell Green, Mechanics' Institute—2nd Fri. in Jan, April, July, Oct—J. Wolfenden, Shaw St., Holywell Green.
- Stalybridge**—Stamford Arms, Stamford St—1st Wed in each month—Samuel Sidebottom, 34, High St.
- Stockport**—Spinners' Institute, Wellington Rd.—2nd Thurs in every month—James Garner, 72, Chapel St., Edgeley.
- Tyldesley**—Castle Hotel, Elliott St.—Thurs following 2nd Tues in March, June, Sept, Dec.—T. Sharples, 47, St. George's St.
- Warrington**—Waggon and Horses, Buttermarket St.—3rd Tues in every month—Arthur Eckersley, 85, Longford St.
- Waterhead**—Plough Inn—1st Wed after 2nd Tues each month—Robert Bardsley 107, Raper St., Waterhead, Oldham.
- Wigan**—Bridgewater Arms, Wallgate—3rd Wed of Jan, March, April, June, July, Sept, Oct, Dec.—T. Coyle, 39, Hutton St., Worthington, Standish, Wigan.

- Yorkshire Province**—Cotton Operatives' Office, Tuel Lane Corner, Sowerby Bridge—2nd Sat in Jan, April, July, Oct.—J. Bates, 4, Dale St., Sowerby Bridge
- General Association Central Offices**—3, Blossom St., Gt. Ancoats St., Manchester—Quarterly Rep. Mtgs. 4th Sat. in March, June, Sept, Dec.—W. Marsland, 30, Berwyn Place, Canterbury St., Ashton-under-Lyne.

---

## THE AMALGAMATED ASSOCIATION OF CARD AND BLOWING ROOM OPERATIVES

---

### DISTRICTS AND SECRETARIES.

- Accrington**.—A. Eidsforth, Post Office Chambers.
- Ashton-under-Lyne**.—W. Hy Carr, J.P., 28, Delamere Street.
- Bolton**.—Jos. Edge, J.P., 77, St. George's Road.
- Blackburn**.—M. Brothers, 56a, Victoria Street.
- Bury**.—Councillor John Duckworth, J.P., Textile Hall.
- Glossop**.—John Gradwell, 56, Edward Street.
- Heywood**.—Wm. Schofield, Trades' Hall, West Street.
- Hyde**.—Walter Gee, 144, George Street.
- Macclesfield**.—A. Bamford, 86, Windmill Street.
- Manchester**.—Wm. Mullin, J.P., Secretary, Central Offices, 2a, Hodson's Court, Corporation Street.
- Mossley**.—Alderman M. B. Farr, J.P., 110, Breeze Hill.
- Oldham**.—M. Connolly, 108, Union Street.
- Preston**.—John Billington, 103, De Lacy Street.
- Rochdale**.—J. J. Kingsley, 5, Baillie Street.
- Stockport**.—Frederick Parker, Textile Hall.
- Wigan**.—M. Carmody, 22, Caroline Street.
- Yorkshire Province**.—Fred Whitworth, 77, Quarry Hill, Ripponden.

---

## LOCAL ASSOCIATIONS OF COTTON OPERATIVES

---

- Accrington**—  
Twisters and Drawers' Association, 9, Aitken St.  
Amalgamated Weavers' Association (Joseph Cross, sec.),  
Ewbank Chambers.
- Ashton-under-Lyne**—  
Ashton-under-Lyne and District Power-Loom Overlookers'  
Association, Stamford Crescent.  
Ashton-under-Lyne Weavers' Association (William Booth,  
sec.), 34, Park Parade.
- Bacup**—  
Rossendale Weavers Winders, and Beamers' Association.  
The Bacup Weavers' Association.

**Bolton—**

- Bolton Men Warpers' Association, Crown and Cushion Hotel, Mealhouse Lane.  
 Bolton Operative Bleachers, Dyers, and Finishers' Association (W. B. Mather, sec.), 19, Wood Street.  
 Bolton Operative Weavers' Association (William Melling, sec.), Spinners' Hall, St. George's Road.  
 Beamers, Twisters, and Drawers' Association (Cooper Binks, sec.), Red Cross Hotel, Bradshawgate.  
 Bolton and District Gaiters and Jacquard Makers' (Operative) Association, Lawries Cafe, Bradshawgate.  
 North and North East Lancashire Tape Sizers' Society (T. Marsden, sec.), Founders' Arms, Ashburner Street.  
 Power Loom Overlookers' Association (Jn. Haslam, sec.) Balmoral Hotel, Bradshawgate.

**Blackburn—**

- N. and N.-E. and S.-E. Lancashire Amalgamated Tape Sizers' Protective Society, 132, Whalley New Road.  
 Blackburn and District Power Loom Overlookers' Association (Joseph Graham, sec.), 3, New Water Street.  
 Blackburn and District Weavers' Association, 1, Clayton St.  
 Amalgamation of Clothlookers and Warehousemen's Association (E. Strong, Secretary).

**Burnley—**

- Burnley and District Weavers, Winders, and Beamers' Association, Weavers' Institute (Fred Thomas, Secretary).  
 Burnley Twisters and Drawers' Association, March Street (R. B. Watson, Secretary).  
 Burnley Power Loom Overlookers' Association, 17a, Market Street (J. Hargreaves, Secretary).  
 Burnley Tape Sizers' Society.

**Church—**Church and Oswaldtwistle Weavers' Association.**Colne—**

- Colne Weavers' Association (T. Shaw, sec.)  
 Northern Counties Textile Trades Federation (T. Shaw, sec.)  
 Colne and District Power Loom Overlookers' Association, 2, Knowsley Street (J. Hartley, sec.).

**Darwen—**

- Darwen Card and Blowing Room Operatives' Society (Joseph Bury, sec.), 46, Sarah Street.  
 Darwen Cloth Lookers and Warehousemen's Association (John Marchington, sec.), 4, Jubilee Street.  
 Darwen Tape Sizers' Society (David Aspden, sec.).  
 Darwen Twisters and Drawers' Association (Peter Duckworth, sec.), Jubilee Street.  
 Darwen Weavers, Winders, and Warpings' Association (D. J. Shackleton, M.P., J.P., sec.; J. Pilkington, assistant sec.), Victoria Street.

**Glasgow—**

- Glasgow and West of Scotland Power Loom Tenters' Society, 15, William Street, Greenhead.

**Haslingden—**

- Haslingden Weavers' Association (George Whittam, sec.), 55, Blackburn Road.

**Heywood—**

- Amalgamated Association of Beamers, Twisters, & Drawers. (W. C. Robinson, sec.).  
 Heywood and District Weavers' Association, Ogden, Sec.



**Huddersfield—**

Huddersfield Cotton Operatives' Association, 9, Northumberland Street.

**Hyde—**

Hyde, Hadfield, and District Weavers, Winders, and Warpers' Association, 27, George Street.

**Macclesfield—**

Power Loom Weavers' Association.

Hand Loom Weavers' Association.

**Manchester—**

The Amalgamated Association of Operative Cotton Spinners, 3, Blossom Street. (For District Branches see page 306.)

Amalgamated Association of Card and Blowing Room Operatives, 2a, Hodson's Court, Corporation Street. (For District Branches see page 309.)

General Union of Associations of Loom Overlookers, "Belvedere," Carill Avenue, Moston, Manchester (J. E. Tattersall (general sec.).

**Nelson—**

Nelson Weavers' Association, Weavers' Institute (William Ward, sec.).

Textile Trades Federation of Nelson, Colne, Brierfield, and District, Weavers' Institute, Nelson (William Ward, sec.)

Nelson and District Clothlookers' Association, Bradley Road (B. Greenwood, sec.).

Nelson and District Power Loom Overlookers' Association, Jude Street (Albert Smith, J.P., sec.).

Nelson and District Warp Dressers' Association, 2a, New Brown Street (James White, sec.).

Nelson and District Twisters and Drawers' Association, 8, Rupert Street (E. Stanley, sec.).

**Oldham—**

Amalgamated Association of Engineers, Carders, and Overlookers, 26, Queen's Road, Middleton Road, Chadderton.

**Padiham—**

Padiham Weavers' Association, Weavers' Institute (Robert Hargreaves, sec.).

Padiham and District Managers, Carders, and Spinning Overlookers' Association, 3, Burnley Road (A. Gardner, sec.).

**Ramsbottom—**

Ramsbottom Weavers, Winders, and Warpers' Association (Thomas Yates Sutcliffe, sec.), Stanley Street.

**Rochdale—**

The Rochdale Warpers' Association (J. S. Isherwood, sec.).

The Rochdale Weavers and Winders' Association (J. H. Holden, sec.).

The Rochdale Warp Dressers' Association (B. Hoyle, sec.).

The Rochdale Twisters and Drawers' Association (E. Lees, sec.).

The Rochdale Loom Overlookers' Association (A. Taylor, sec.).

The Rochdale Clothlookers' Association, J. Leeming, sec.).

**Stockport—**Stockport and District Weavers, Winders, Beamers, and Reelers' Association, Mechanics' Institute, Stockport. Secretary, Thomas Yates.

**Todmorden—**

Northern Counties Amalgamated Society of Weavers (James Wilkinson, sec.).

## HOLIDAYS IN COTTON DISTRICTS

The *Summer* holidays given below are in some few cases liable to slight alterations. Travelers purposing to visit the districts a week or so before or after the dates mentioned, are therefore advised to assure themselves that no alterations have been made.

### Accrington

New Year's Day.  
 Good Friday and following day.  
 Whitsun—Monday and Tuesday.  
 August—Stop Friday night after first Thursday, until Monday but one following.  
 Christmas Day.

### Ashton, Dukinfield, and Hurst

First Saturday in the year.  
 Good Friday, following day, and Easter Monday.  
 Whitsun—Friday and Saturday.  
 Wakes—Friday night to Monday but one following.  
 (Wakes Sunday is first Sunday after Aug. 15.)  
 Christmas Day (when a Saturday, to be considered a day of ten hours. When a Sunday, the following Monday to be a holiday).

### Atherton

New Year's Day.  
 Good Friday and day following.  
 June—Last Saturday and week following. (If Bolton has same time.)  
 September—Second Monday and following day.  
 Christmas Day.

### Bollington

New Year's Day.  
 Good Friday and day following.  
 Whitsun—Stop Thursday noon till Monday following.  
 July—Wakes holiday, commencing week-end before last Sunday (*i.e.*, stop Friday night until Monday but one following).  
 Christmas Day.

### Blackburn

New Year's Day.  
 Good Friday and day following.  
 Whitsun—Three days: Saturday before Whitsun; also Monday and Tuesday.  
 August—Six days, from first Saturday after Bank Holiday.  
 Christmas Day.

### Bolton

New Year's Day.  
 Good Friday and day following.  
 June—Stop last Friday in June until Monday but one following.  
 September—First Monday and Tuesday.  
 Christmas Day.

## HOLIDAYS IN COTTON DISTRICTS.—Continued.

**Bradford**

Easter Monday and Tuesday.  
Whitsun—Monday and Tuesday.  
August Bank Holiday.  
Christmas Day and day following.

**Burnley**

Good Friday and day following.  
July—Saturday after first Thursday, and following week.  
September—Monday after first Saturday and following two days.  
Christmas Day.

**Bury and Elton**

New Year's Day.  
Good Friday.  
Whitsun—Friday and Saturday and following Monday.  
August—First Saturday after Bank Holiday, and whole of following week.  
Christmas Day.

**Chorley**

New Year's Day.  
Good Friday and day following  
Whit Monday.  
July—Third Saturday till following Monday week.  
September—First Saturday and following Monday.  
Christmas Day. (When New Year and Christmas Days fall on a Sunday, the following days to be holidays.)

**Colne**

Good Friday and day following.  
Whitsun—Monday and day following.  
Second Saturday in August and following week.  
Christmas Day and day following.

**Darwen**

New Year's Day.  
Good Friday and following Saturday.  
July—Stop on Friday night previous to third Monday, until following Monday week.  
September—Second Monday and following Tuesday.  
Christmas Day.

**Droylsden and District**

Good Friday and day following, and Easter Monday.  
Whitsun—Thursday afternoon, Friday and Saturday.  
Wakes—From Friday night to Monday but one following. (Wakes Sunday is first Sunday after August 15.)  
Christmas Day.

**Farnworth**

New Year's Day.  
Good Friday and day following.  
June—Last Saturday until Monday but one following.  
September—Monday and Tuesday after second Saturday.  
Christmas Day.

**HOLIDAYS IN COTTON DISTRICTS.—Continued.****Haslingden**

New Year's Day.  
 Good Friday and following day.  
 Whitsun—Friday and Saturday after Whit Sunday,  
 July—Third week.  
 September—First Monday.  
 Christmas Day.

**Hindley**

Good Friday and following day.  
 July—Stop first Friday before first Saturday, until  
 Monday but one following.  
 September—Second Monday and following day.  
 Christmas Day and New Year's Day.

**Huddersfield**

No official holidays, but 105½ hours is agreed upon,  
 each firm making its own arrangements.

**Hyde**

Good Friday and following day.  
 Whitsun—From Thursday noon until Tuesday fol-  
 lowing.  
 September—Stop first Friday night until Monday but  
 one following.  
 Christmas Day.

**Lancaster**

Easter—Saturday before Easter Sunday, and Monday  
 and Tuesday.  
 Whitsun—Same as Easter.  
 August—A full week, commencing first Saturday.  
 (This year August 1.)  
 Christmas Day.

**Leigh**

New Year's Day.  
 Good Friday and day following.  
 July—First Saturday and following week.  
 September—Second Monday and day following.  
 Christmas Day.

**Macclesfield**

Good Friday, day following, and Easter Monday.  
 "Barnaby" Saturday (June 21 or Saturday nearest  
 thereto) and week following.  
 Wakes—Monday and Tuesday. (Wakes Sunday is Sep-  
 tember 29, or first Sunday after that date.)  
 Christmas Day and Boxing Day.

**Middleton**

Easter Monday and Tuesday.  
 Whitsun—Whit Friday and Saturday, and following  
 (Trinity) Monday.  
 Wakes—Stop Friday noon till following Monday but  
 one.  
 August—Last Saturday but one.  
 Christmas Day.

**Middleton Junction**

Easter Monday and Tuesday.  
 Whitsun—Friday and Saturday and following Monday.  
 August—Stop for Oldham Wakes (from last Friday till  
 Monday but one following).  
 Christmas Day.

## HOLIDAYS IN COTTON DISTRICTS.—Continued.

**Mossley**

New Year—First Friday and Saturday in New Year (except when December 31 and January 1 are Friday and Saturday). New Year's Day is not a holiday except it be Friday or Saturday, as above.

Easter—Friday and Saturday.

Whitsun—Friday and Saturday.

Wakes—Last Saturday in July, and following week.

Christmas Day.

**Nelson**

Good Friday and day following.

Last Friday night in June and following week.

Second Monday in September and two following days.

Christmas Day.

**New Mills, Strines, Hayfield, etc.**

September—Stop first Saturday for a week.

**Oldham**

Easter Monday, and either Easter Tuesday or Good Friday—at the option of the employer.

Whit Friday and Saturday, and following Monday.

August—Last Saturday and following week.

Christmas Day.

**Pendlebury**

New Year's Day.

Good Friday and day following.

Whitsun—Thursday, Friday, and Saturday.

August—The Bank Holiday week.

Christmas Day.

**Preston**

Good Friday and following day.

Whitsun—Saturday before, and Whit Monday and Tuesday.

August—Full week from second Monday.

Christmas and Boxing Days.

**Preston**

Easter Monday.

Whitsun—Monday, Tuesday, and Wednesday.

August—Second Monday to following Monday.

Christmas Day and day following

**Padiham**

New Year's Day.

Good Friday and day following.

Whitsun—Monday and Tuesday.

July—Stop last Friday night until Monday but one following. Christmas Day.

**Reddish**

New Year's Day.

Good Friday and day following.

Whitsun—Thursday, Friday, and Saturday.

August—Week following second Saturday.

Christmas Day.

**Rochdale**

Good Friday and following day.

Whitsun—From Thursday noon until Monday night of following week.

Wakes—Saturday after second Sunday in August and following week. Christmas Day.

## HOLIDAYS IN COTTON DISTRICTS.—Continued.

**Royton**

Easter Monday and Tuesday.  
 Whitsun—Friday, Saturday, and following (Trinity)  
 Monday.  
 August—First Saturday and all of following week.  
 Christmas Day.

**Sowerby Bridge and Ripponden**

Whitsun—Monday and Tuesday.  
 August—A full week.  
 Christmas Day.

**Stalybridge**

Easter Friday and Saturday.  
 Whitsun—Friday and Saturday.  
 Wakes—Friday night to end of following week.  
 (Wakes Sunday is on, or first Sunday after,  
 July 18.)  
 September—Fourth Saturday and following Monday.  
 Christmas Day.

**Stockport**

Easter—Friday and Saturday, and following Monday.  
 Whitsun—Friday and Saturday.  
 August—Full week following second Sunday.  
 Christmas Day and following day.

**Tyldesley**

Proposed holidays (not yet settled)—New Year's Day;  
 Good Friday and following day. Third Satur-  
 day in June, and following week. Second  
 Monday and following day in September.  
 Christmas Day.

**Wigan**

New Year's Day.  
 Good Friday.  
 Whit Monday.  
 August—Week commencing first Monday.  
 Christmas Day.

## APPROXIMATE COST OF WORKING COTTON.

Including Wages, Fixed Expenses, Dep., etc., for Carded Yarns.

Counts	40's.....	3·007d. per lb.
"	50's.....	3·7 "
"	60's.....	4·62 "
"	72's.....	5·5 "

## COST FOR LABOUR ONLY.

Counts	50's T, carded.....	1.76d. per lb.
"	90's W, carded .....	3·35 "
"	90's W, combed .....	3·45 "
"	80's T, carded.....	3 "

## INDEX.

	PAGE		PAGE
<b>A</b>			
Absorbent Cotton .....	196	Card Clothing .....	79-82
Accessories for Mule Spg. Mill, 51; for Ring ditto.....	41	—Cutting & Lacing ((Jacquard) .....	253
African Cottons .....	13 & 14	Carding Engines, 77-85; Dust from, 85; Locking Covers... ..	83
Alhambra Quilts .....	263	—Engines: Revolving Flat, 78- 80; Roller & Clearer, 78 & 80; "Union," 79; Waste, 189 & 190; "Wellman" .....	78
American Cotton .....	10	Cardroom Machinery (Ring Mill), 37; (Mule Mill).....	46
Analysis of Cloth .....	303	Caustic Soda Bath.....	277
Arbitration (Cotton) .....	23	Change-Wheel (Loom) Tables .....	245-246
<b>B</b>		Chaining & Linking Machine... ..	178
Badly—"covered" Cloth.....	311	Chain or Warp Dyeing Machine .....	182
Balance, Yarn-Testing.....	150	Check Fabrics .....	263
Bale Breakers .....	65	Cheeses, Yarn in: Sequence of Machines .....	54
Ball Warp Beamer, 216; Sizer... ..	226	—Winding .....	205
—Warper .....	210	C.i.f. Cotton Contract.....	19
Banding Machines .....	197	Classification of Cottons.....	15
—, Spindle-Driving .....	197	Clearer Waste Thread Extractor .....	68
"Bare" Cloth .....	311	Clearing Frame for Sewing Thread .....	178
Beamer: Ball Warp, 216; Warp .....	211	—or Gassing Yarn .....	169
Beams, Slack-sided.....	212	Cloth Analysis .....	303
Bedford Cords .....	263	Cloth, Cost or .....	305-310
Beetling Machine .....	274	—Covering Machine, 132; Cut- ting ditto, 312; Mellowing ditto, 297; Press.....	255
Belt Driving .....	361	—"Looking" .....	311
Bevel of Mule Spindles .....	123	—Raising .....	297
Bleaching, 265-274; Piece-Goods, 271; Print Cloth, 273; Sew- ing Thread, 177 & 178; Yarn .....	269	Coloured Goods: Weaving Schemes .....	202 & 203
—Sequence of Machines.....	266	Colouring Matters, etc.....	284
Blowing-room Machinery: for Ring Mill, 35-37; for Mule Mill .....	44-46	Comber: Heilmann, 89-93; Nas- mith, 94; Whitin .....	93
Bobbins, Power absorbed by.....	140-142	Combing: Machines & Proces- ses .....	86-95
—Stripping Apparatus.....	155	Conditioning Machine (Yarn)... ..	158
—Yards on Set.....	163	Cone Winding .....	205
—Weight of Cotton on, 106; ditto of Set.....	163	Consumption of Cotton, World's .....	29
Boilers .....	340-349	Contract Forms, Cotton .....	19-22 & 27
Boiling Sewing Thread.....	178	Cop Tube Setter (Mules), 127; Tubing Device (ditto).....	127
Bowl (Calender) Grinder.....	296	—Winder .....	208
Box Marks .....	312	Cord Effects.....	257 & 263
Brazilian Cotton .....	11	Corduroys .....	262
Breaker, Waste .....	189	Corkscrew Twills, 258; Yarn.....	154
Breaking-up Machine (Waste)... ..	189	Cost of Cloth .....	305-310
Brighton Weaves .....	258	—of Yarn per lb., Apportioned .....	62
Brilliantes .....	263	Cotton & Yarn Testing.....	145-155
British Empire Cotton .....	13	—for Various Counts .....	61
Brocades .....	263	—Gins .....	64
Broken Patterns .....	311	—Leading Growths.....	9 & 15
Buckley Openers .....	73	—Linen, & Worsted Yarn Nos. .....	157
Bundling Press (Yarn) .....	175	—Waste: Sequence of Machines .....	186
—Yarns, 174; Sequence of Ma- chines for .....	160	—Waste, Wadding, & Banding .....	185-198
<b>C</b>			
Cable Yarns, Reverse.....	175		
Calender Bowl Grinder .....	296		
Calendering (Roller) Machine... ..	133		
Calico Weave .....	257		
Cambrics .....	263		

	PAGE		PAGE
Counts, Cottons suitable for.....	61	Dust Flues, 37; Trunks.....	71
— "Nominal" & "Actual".....	313	—from Carding Engines.....	84
—Testing for .....	148	Dyeing .....	283-294
"Covered" Cloth .....	257	—Mercerised Goods, 283; Sew-	
Covering Draft Rollers .....	132-137	ing Thread, 179; Warps,	
Creeper Feed Table .....	70	in Hank, 289; ditto in Cop 290	
Cretannes, Finishing .....	295	Dynamometers, Transmission... 144	
Crighton Openers .....	72		
Crimp Stripes .....	257 & 263	<b>E</b>	
Crochet & Lace Yarns .....	182	East African Cotton.....13 & 14	
Cross Reeling .....	171	—Indian Cotton .....	11
Cup Winder .....	206	Economisers .....	346
Cuts, Marking of .....	230	Egyptian Cotton .....	12
Cutting Cloth (Machine).....	312	Elasticity of Yarn, Testing..... 150	
—Velvet .....	261	Electrical Driving.....363-369	
<b>D</b>		—Fire Alarm .....	330
Defective Yarns .....	153	— "Ends Out" .....	311
Deferred Delivery (Cotton) Con-		Engine-cleaning Waste .....	188
tract .....	22	Engines, Steam .....	349-353
Derby Doubler, 86; (Waste).....	190	Extracting Threads .....	303
Dhooties .....	263	<b>F</b>	
Diamond or Grant Reeling.....	171	Factories Act, Cotton Cloth	
Dirty Yarn .....	153	324 & 326	
Disc Winder .....	207	Faulty Cloth: its Causes .....	311
Dividend of Loom .....	243	Feet, Inches, & Metres Table... 302	
Domestics .....	263	Fencing of Machinery..... 369	
Doria Stripes .....	263	Figure-8 Tie Reeling .....	171
Doubled Yarn-Bundling, 175;		Fine Counts, Sequence of Ma-	
Strengths of .....	182	chines for .....	53
Doubler, The Derby .....	86	—Roving Frame .....	102
Double Twisted Yarn .....	184	—Spinning Mule .....	26
Doubling & Doubling-Winding,		Finisher Card (Waste) .....	190
159-169		Finishing, 294-298; Sewing	
—and Gassing Installation.....	176	Thread .....	179
—English & Scotch.....	162	Fire Alarm, Electric .....	330
—Travellers for.....164-165		—Insurance .....	329
—Twister for Sewing Thread		Fireproof Flooring .....	373
177 & 178		Fires in Cotton Mills .....	62
Drafting .....	128-131	Flannelettes .....	263
Draft Rollers: Covering, 132-137;		Floats .....	311
Diameters for Counts (Mule) 124		Flooring of Mill.....372 & 373	
Drafts & Hank Rovings.....55-60		Florentine Twill .....	258
Draw Frame & Lap Machine... 88		Flyer Frames .....	100-107
Drawing Frame, 96-100; for		Folding or Plaiting Machine... 254	
Mule Spg., 47; for Ring		Four-fold Preventer .....	165
38		French System of Numbering... 155	
—Machines & Processes.....96-110		Friction Clutches .....	355
Dresser Sizer .....	226	Fustian Cutting .....	261
Dressing Frame, Yorkshire.....	217	Fustians .....	263
Drillettes .....	263	Futures (Cotton) Market..... 26	
Driving: by Belts, 361; Elec-		<b>G</b>	
tricity, 363; Gas, 337;		Galatea Twills .....	258
Ropes, 358; Water Power... 332		Gas Lighting of Mills, 330;	
Drum Winder .....	204	Power .....	337
Dry Doubling, Travellers for... 165		Gassing Installation .....	176
Drying Machine, Hank .....	232	—or Clearing Yarn .....	169
—Mercerised Goods, 283; Sew-		Gauze Fabrics .....	260
ing Thread, 179; Warps,		Gears of Looms .....	243
228; Yarn .....	291	Genoa Velvets .....	261
Dumping Machine (Sewing		Gins, Cotton .....	64
Thread) .....	179	Grant or Diamond Reeling..... 171	



	PAGE		PAGE
Grey Cloth Analysis .....	303	Lea Tester for Yarn .....	150
—Cloths, Plain, 257; Weaving Schemes .....	202 & 207	Leather, Breaking Stresses.....	135
—Yarns, Preparing .....	173	—Cutting Board .....	132
Grinding (Leather) Machine .....	132 & 134	—Rollers, Duration of.....	135
Growths of Cotton, Leading.....	9	Lengths & Weights of Yarns... 156	
Gumming Machine (Wadding)... 194		—of Cloth (Invoicing) .....	313
<b>H</b>		Leno & Gauze Fabrics .....	260 & 264
Hank Drying, 232; Sizing, 231; Stretching, Shaking, etc.... 232		Lighting by Gas .....	330
—Rovings & Drafts...55, 106, & 125		Linen, Cotton, & Worsted Yarn Nos. ....	157
Hard Waste, 187; Machinery... 188		—Finish on Cotton .....	296
Harvard Twill .....	258	Link Regulator for Warper.....	215
Heilmann Comber.....	89-93	Lint, Surgical .....	196
Herringbone Twills.....	258 & 263	Liverpool Market, The.....	17-28
Honeycomb Weaves .....	258	Locking Carding Engine Covers "Long" and "Short" Stick (Cloth Measure) .....	83
Hopper Feeder .....	69	—Collars .....	138
Hopsack Weave .....	257	—System (Wadding) .....	194
Horizontal Spindle Winder .....	209	Looms, 240-254; Speeds of.....	242
Hosiery, Lace, etc., Yarns...176-184		Looped Weft .....	311
—Yarn Mule .....	127	<b>M</b>	
Huckaback Weaves .....	258	Madapolams .....	264
Humid Cloth Factories...324 & 326		Maize Starch .....	220
Humidity in Weaving Sheds .....	324 & 329	Market Whites .....	273
Hydraulic Installations .....	336	Marking for Bleaching.....	271
Hydro-Extractor, Sewi'g Thread 179		—of Cuts .....	230
Hydrometer Scales .....	299	Matting Weaves .....	257
Hygrometers .....	328	Measuring Cloth .....	298 & 313
<b>I</b>		Mechanical Stokers .....	341
Imports (Cotton) into L'pool... 18		Mellowing Machine .....	297
Intermediate Frame.....	101	Mercerised Goods, Drying.....	283
—or 2nd Slubbing (Mule Spg.), 48; (Ring) .....	39	Mercerising Cloth, 279-283; Yarn .....	275-279 & 281
International Statistics .....	29-32	Metal Carriages (Mule) .....	125
Indian Corn Starch .....	220	Metres, Feet, & Inches Table... 302	
Invoicing .....	313	Mildew .....	219 & 312
Iron-mould Stains .....	312	Mill Flooring, 372 & 373; Roofing .....	370
Irregular Yarn .....	154	Missed Picks .....	311
Italians .....	263	Mixing or Conveying Lattices 66	
<b>J</b>		Mixings for Size .....	221
Jaconettes .....	263	Mock Leno Weaves .....	260
Jacquard, The .....	252	Molstening (Warp) Apparatus... 254	
—Card Cutting & Lacing Machines .....	253	Moisture in Cotton & Yarn..... 145	
Jean Twills .....	258 & 263	Moting & Shearing .....	271
<b>K</b>		Mule & Ring Mills: Comparison.....	138 & 139
Knotters, Thread .....	169	—Spinning: 43-54 & 119-128; Raw Material for, 44; Sequences of Machines 43, 53, & 54	
<b>L</b>		—Spinning Mill: Accessories, 43-54; Summary of Production .....	52
Lace, Crochet, & Hosiery Yarns .....	176-184	—The, 49 & 50; 119-128; for Fine Spg., 126; for Hosiery Yarn, 127; for Waste (the "Billy") 191	
Lambskins .....	264	—The: Bevel Spindles, 123; Metal Carriages, 125; Strap-forks .....	126
Lap Machine: Ribbon, 86; Sliver, 86; with Draw-Frame .....	88		
Lappet Cloths .....	260		
Laps, Approximate Weights..... 88			
Lattices, Mixing or Conveying 66			
Lawns .....	264		
Lea or Straight Reeling .....	171		

	PAGE
Mule, The: Power for Driving, 142; Speed of Spindles, 121; Spindle Lengths, Setting, etc., 123; Stretch for Various Counts, 121; Turns per Inch .....	122
—Went, Bleaching, etc. ....	205
—Yarn: Hank Rovings and Drafts .....	55-60
Mulls .....	264
Multipliers for Turns per Inch .....	104
Muslins .....	264

**N**

Nankeen Weaves .....	258
Nasmith Comber, The .....	94
Nepped Yarn .....	153 & 185
Net Weight Cotton Contract... ..	21
Northrop Loom, The .....	250 & 251
Numbering of Yarns .....	155 & 157
Nyasaland Cotton .....	15

**O**

Office, The .....	313-323
Oil Extractor and Measurer (Ring Frame) .....	119
—Filter, Waste .....	354
—Spots & Stains .....	312
Openers: Porcupine, 70; Roving Waste, 67; Waste, 193; Various .....	70, 72-75
Opening, Scutching, Carding, Combing, Drawing .....	63-110
Oven for Moisture Testing .....	146
Overhead Run-ways .....	212
Oxford Checks and Stripes.....	264

**P**

Particulars for Weaving Prices .....	247
Patent Specifications, List of... ..	317
Peruvian Cotton .....	11
Piano Card-Cutter .....	253
Picker Spindle Lubricator .....	242
Pickles's Gear (Looms) .....	244
Picks & Change-Wheels .....	245-246
Piece-Goods, Bleaching .....	271
Piecing (Leather) Press .....	133
Pile Fabrics .....	260
Plain Weave .....	257
Plaiting or Folding Machine... ..	254
Plate Card-Cutter .....	253
Plush Fabrics .....	261
Polishing Sewing Thread .....	179 & 180
Poplins .....	257
Porcupine Opener .....	70, 71, 72, & 75
Preparing Grey Yarns .....	173
Press, Yarn Bundling, 175; Cloth .....	255
Prices of Cotton: Diagram .....	16
—for Weaving.....	247 & 307-310
Print Cloth, Bleaching .....	273

	PAGE
Pulling-on (Leather) Apparatus .....	133

**Q**

Quadrant for Yarn Testing ... ..	149
—Regulator for Warper .....	213
Quilts, Alhambra, etc. ....	263

**R**

Railway Rates .....	314
Raising of Cloth .....	297
Raw Material for Ring Yarn, 35; ditto Mule .....	44
Reed & Pick, Invoicing .....	313
Reedy Cloth .....	257 & 311
Reeling .....	171 & 172
Reels: Thread-holder and Cutter .....	172
Repps, True & Imitation .....	257
Regains, Standard .....	148
Regatta Twills .....	258 & 264
Regularity, Testing Yarn for... ..	152
Reverse Cable Yarns .....	175
Revolving Flat Carding Engine .....	78-80
Ribbon Lap Machine .....	87
Ring & Mule Mills: Comparisons .....	138 & 139
—Frame, The: for Doubling, 163; for Spinning, 40; for Waste ditto .....	117
—Frame, The: H.P. for, 112; Oil Extractor and Measurer, 119; Rings & Travellers for, 114; Rules for Changes, 117; Setting Thread Guides, 117; Variable Speeds .....	113
—Spg.: 34-42 & 111-119; Raw Material for, 35; Sequences of Machines .....	34 & 54
—Spg. Mill: Accessories, 41; Equipment & Processes, 34-42; Summary of Production .....	42
—Tie Reeling .....	171
—Yarn: Hank Rovings and Drafts, 55, 57, 58, & 60; Strengths of .....	154
Roof of Mill or Shed .....	370
Rope Driving .....	358
Roving Frame for Mule Mill, 49; for Ring ditto .....	40
—Machinery .....	40 & 102-107
—Waste, 187; ditto Opener .....	67
Roller & Clearer Carding Engine .....	78 & 80
—Ending Machine .....	133
—Leather, Duration of, 135; Recipes .....	136 & 137
—s, Dia. of, for Speed Frames .....	105
—s for Various Cottons .....	112
Running-down (Waste) Machine .....	188
—off (Warp) Machine .....	216
Run-ways, Overhead .....	212

	PAGE		PAGE
<b>S</b>			
Satin or Sateen Weaves	258 & 264	Spindle Footstep Protector	
Scind Cotton	13	(Mule)	128
Scotch Feed (Waste Machinery)	191	—Lengths, Mule	123
Scroop of Silk, on Cottons	295	—s of the World	29 & 32
Scutcher, The, 75-77; Waste...	189	Spinning & Weaving: Sequence	
Sea Island Cotton	13	of Machines	200
Sectional Warper	213	—Machines, Testing of	140-145
Selvedges, Bad	311	Splicing Machine	133
Sequence of Machines: Dia-		Split-Drum Winder	206
grams—Ring Yarn	34	Splits	264
—Ditto, ditto, Mule Yarn	45	Sponge Weaves	258
—Ditto, ditto, Fine Counts	53	Spooling Sewing Thread	180 & 181
—Ditto, ditto, Cheese Yarns	54	Spot Cotton Market	18-26
—Ditto, ditto, Yarn for Bund-		Sprinklers	329
ling	160	Stained Yarn	153
—Ditto, ditto, Cotton Waste	186	Stains, Iron-mould	312
—Ditto, ditto, Spinning and		Standard "Regains"	148
Weaving	200	—Weaves	257
—Ditto, ditto, Bleaching Cloths	266	Starch, Maize	220
—Ditto, do., Print-Cloth Bleach	273	Statistics, International	29-32
Serge Twills	258 & 264	Steam Engines	349-353
Setting Thread-Guides in Ring		Steaming in Weaving Sheds	324-329
Frames	117	Stitching for Bleaching	271
Sewing Thread: Machines and		Stokers, Mechanical	341
Processes	176-181	Straight or Lea Reeling	171
—Thread, Making-up	175	Stretch (Mule) for Various	
Shafting	353-357	Counts	121
Shaker for Waste	193	Strength of Yarn, Testing	150
Shearing & Moting	271	—s of Doubled Yarn, 182; of	
Shirtings, Finishing	295	Ring Yarn	154
Short System (Wadding)	196	Stringeing	277
Singeing	272	Structure of Mills	370-373
Single-Thread Testers	152	Stud and Tin Roller Wheels	234-238
Size: Mixings, 221; Mixing		Sulphuric Acid Bath	279
Apparatus	224	Surgical Lint	196
—Removing	303	<b>T</b>	
—Weight of	247	Tabby Velvets	261
Sizing Hanks, 231; Warps	217	—Weave	257
—Hints on	229	Tachometers (Speed Indicators)	144
—Machinery	226	Take-up Motions (Looms)	243
slack-sided Beams	212	Taujibs	264
Slasher Sizer	227	Tare on Cotton	28
Slide Rule Calculations (Mule),		T-Cloths	264
125; Cloth	305	Terry Pile Fabrics	261
Slips (Velvets)	262	Testing Cotton & Yarn	145-155
Sliver Lap Machine	86	—(Roller) Apparatus	134
Slubbing Frame, 100; for Mule		—Spinning Machines	140-145
Spg., 47; for Ring ditto	39	Thermometer Scales	300
Slubs or Ooze in Yarn	153	Thread Extractor (from Clearer	
Smashes or Traps	311	Waste)	68
Snarls in Yarn	153	—Guides, Setting, in Ring	
Snicks in Yarn	153	Frames	117
Softening Warp Yarns	218	—Holder & Cutter for Reels	172
Soft Waste, 187; Machinery	192	—Knotters	169
solid Banding	197	—Lace, etc., Yarns for	176-184
Speed Indicators	144	—Sewing	176-181
—s: Mule Spindles	121	—s, Extracting	305
—s: Variation in Ring Frames	113	Ticket Numbers & Yarn Counts	181
Spindle Bevels, Mule	123	Tin Roller & Stud Wheels	234-238
—Driving Banding	197	Tragasol Gum	218 & 224
		Transmission Dynamometers	144

	PAGE
Traps or Smashes .....	311
Travellers for Wet Doubling, 164; for Dry ditto, 165; for two Doublings .....	165
—and Rings .....	114
Truing & Varnishing Machine	133
Tubular Banding .....	197
Turbine Motors .....	334
Turkish Towels .....	264
Turns per Inch .....	104 & 122
Twaddel Hydrometer .....	220
Twills .....	258 & 264
Twiners, Self-acting .....	166
Twisted Banding .....	197
Twist in Yarn for Mercerising	275
—Testing for, 151; Weight of...	247
Twisting-in or Tying-in of Warps .....	233

**U**

Uganda Cotton .....	14
Uneven Cloth .....	311
Union Carding Engine.....	79
Universal Yarn Numbering.....	157

**V**

Variable Speeds in Ring Frames .....	113
Velvet, Common, 262; Genoa...	261
—Cutting .....	261
—and Velveteens .....	261
Ventilation, etc. ....	326
Vomiter Boiler for Sewing Thread .....	178

**W**

Wadding, Manufacture of.....	194
Warehouse, The .....	301-313
Warpers & Warping .....	210
Warp Moistening Apparatus.....	254
—or Chain Dyeing Machine.....	182
—Sizing .....	217
—Winders .....	203
—s, Drying by Air .....	228
—s, "Nominal" and "Actual" .....	313
—s, Twisting-in or Tying-in.....	233
Washing Sewing Thread.....	178
Waste (Clearer): Thread Ex- tractor .....	68
—Cotton, 187; Engine-cleaning	188
—Hard, 187; Machinery.....	188
—Opener & Shaker, 193; (Rov- ing) .....	187
—Preparing Machinery .....	189
—Roving, 187; Opener .....	67
—Soft, 187; Machinery.....	192
—Spinning on Ring Frames...	117
Water Cooling Plant .....	348
—Power Driving .....	332
Waterproof Flooring .....	373
Weaves, Standard .....	257

**PAGE**

Weaving: Preparatory & Sizing, 199-237; Looms, etc., 240-264; Summary of Machinery.....	201
—Price List, 247; Prices of .....	307-310
—Shed, Electric Driving .....	367
Weft, Looped, 311; Picking under .....	312
—"Nominal" and "Actual"...	313
—Weight of .....	247-250
—Winders .....	206
—Yarn for Grey Cloth .....	203
Weight Hook, Self-lubricating...	137
Weighting Warp Yarns .....	218
Weights & Lengths of Yarns...	156
—for Testing Yarn .....	155
—of Cotton on Bobbins.....	106
—of Twist, Weft, & Size.....	247
—of Yarns after Bleaching, etc.	292
Wellman Carding Engine.....	78
West African Cotton .....	13 & 14
—Indian Cotton .....	13 & 14
Wet Doubling, Travellers for...	164
Whitin Comber, The .....	93
Width, Actual & Nominal .....	313
Willow (Soft Waste) .....	192
Winders: Drum, 204; Split- drum, 206; Vertical Spindle, 203; Weft .....	206
—Doubling .....	166-168
—for Sewing Thread 177, 178, 180, & 181	
Winding, Cheese & Cone .....	205
—(Doubling-) .....	166
Worsted, Linen, & Cotton Yarn Nos. ....	157
Wrap Reel for Yarn Testing...	149
—Tables .....	107-110

**Y**

Yarn Counts & Ticket Numbers 181	
—in Cheeses: Sequence of Ma- chines .....	54
—Measure .....	155
Yarns: Bleaching, 269; Bund- ling, 174; Conditioning, 158; Drying, 291; Dyeing of (Factory Law), 292; Ex- amining, 152; Preparing grey, 173; Testing .....	145-155
—Crochet & Lace, 182; Double Twisted, 184; Nepped, 183; Reverse Cable, 175; Various. Numbering .....	157
—Defects in, 153; Lengths and Weights, 156 and 292; Strengths of Ring, 154; Twist in, 275; Weight after Bleaching, etc. ....	292
Yorkshire Dressing Frame.....	217



---

DIARY 1910

---



## CALENDAR for 1910.

JANUARY.		FEBRUARY.		MARCH.		APRIL.	
S.	2 9 16 23 30	S.	.. 6 13 20 27	S.	.. 6 13 20 27	S.	.. 3 10 17 24
M.	3 10 17 24 31	M.	.. 7 14 21 28	M.	.. 7 14 21 28	M.	.. 4 11 18 25
Tu.	4 11 18 25 ..	Tu.	1 8 15 22 ..	Tu.	1 8 15 22 29	Tu.	.. 5 12 19 26
W.	5 12 19 26 ..	W.	2 9 16 23 ..	W.	2 9 16 23 30	W.	.. 6 13 20 27
Th.	6 13 20 27 ..	Th.	3 10 17 24 ..	Th.	3 10 17 24 31	Th.	.. 7 14 21 28
F.	7 14 21 28 ..	F.	4 11 18 25 ..	F.	4 11 18 25 ..	F.	1 8 15 22 29
S.	1 8 15 22 29 ..	S.	5 12 19 26 ..	S.	5 12 19 26 ..	S.	2 9 16 23 30
MAY.		JUNE.		JULY.		AUGUST.	
S.	1 8 15 22 29	S.	.. 5 12 19 26	S.	3 10 17 24 31	S.	.. 7 14 21 28
M.	2 9 16 23 30	M.	.. 6 13 20 27	M.	4 11 18 25 ..	M.	1 8 15 22 29
Tu.	3 10 17 24 31	Tu.	.. 7 14 21 28	Tu.	5 12 19 26 ..	Tu.	2 9 16 23 30
W.	4 11 18 25 ..	W.	1 8 15 22 29	W.	6 13 20 27 ..	W.	3 10 17 24 31
Th.	5 12 19 26 ..	Th.	2 9 16 23 30	Th.	7 14 21 28 ..	Th.	4 11 18 25 ..
F.	6 13 20 27 ..	F.	3 10 17 24 ..	F.	1 8 15 22 29 ..	F.	5 12 19 26 ..
S.	7 14 21 28 ..	S.	4 11 18 25 ..	S.	2 9 16 23 30 ..	S.	6 13 20 27 ..
SEPTEMBER.		OCTOBER.		NOVEMBER.		DECEMBER.	
S.	.. 4 11 18 25	S.	2 9 16 23 30	S.	.. 6 13 20 27	S.	.. 4 11 18 25
M.	.. 5 12 19 26	M.	3 10 17 24 31	M.	.. 7 14 21 28	M.	.. 5 12 19 26
Tu.	.. 6 13 20 27	Tu.	4 11 18 25 ..	Tu.	1 8 15 22 29	Tu.	.. 6 13 20 27
W.	.. 7 14 21 28	W.	5 12 19 26 ..	W.	2 9 16 23 30	W.	.. 7 14 21 28
Th.	1 8 15 22 29	Th.	6 13 20 27 ..	Th.	3 10 17 24 ..	Th.	1 8 15 22 29
F.	2 9 16 23 30	F.	7 14 21 28 ..	F.	4 11 18 25 ..	F.	2 9 16 23 30
S.	3 10 17 24 ..	S.	1 8 15 22 29 ..	S.	5 12 19 26 ..	S.	3 10 17 24 31

### BANK HOLIDAYS, 1910.

ENGLAND AND IRELAND.—Good Friday, March 25. Easter Monday, March 28. Whit Monday, May 16. First Monday in August, August 1. Christmas Day, December 25. Boxing Day, December 26. St. Patrick's Day (Ireland only), March 17.

SCOTLAND.—New Year's Day, January 1. Good Friday, March 25. First Monday in May, May 2. First Monday in August, August 1. Christmas Day, December 25. On Fast Days and Local Holidays the Bank Hours in Scotland are from 9 to 10-30 a.m.

## — 1911 —

JANUARY.		FEBRUARY.		MARCH.		APRIL.	
S	1 8 15 22 29	S	... 5 12 19 26	S	... 5 12 19 26	S	30 2 9 16 23
M	2 9 16 23 30	M	... 6 13 20 27	M	... 6 13 20 27	M	... 3 10 17 24
Tu	3 10 17 24 31	Tu	... 7 14 21 28	Tu	... 7 14 21 28	Tu	... 4 11 18 25
W	4 11 18 25 ...	W	1 8 15 22 ...	W	1 8 15 22 29	W	... 5 12 19 26
Th	5 12 19 26 ...	Th	2 9 16 23 ...	Th	2 9 16 23 30	Th	... 6 13 20 27
F	6 13 20 27 ...	F	3 10 17 24 ...	F	3 10 17 24 31	F	... 7 14 21 28
S	7 14 21 28 ...	S	4 11 18 25 ...	S	4 11 18 25 ...	S	1 8 15 22 29

DIARY, 1910

---

JANUARY, 1910.

1. **Saturday.**

New Year's Day.

“TEXTILE MERCURY” ANNUALS—

---

JANUARY, 1910.

2. Sunday.

3. Monday.

4. Tuesday.

5. Wednesday.  
Dividends due.

6. Thursday.

7. Friday.

8. Saturday.



# DIARY, 1910

---

## JANUARY, 1910.

**9. Sunday.**

Christmas Fire Ins. ceases.

**10. Monday.**

**11. Tuesday.**

Hilary Sittings begin.

**12. Wednesday.**

**13. Thursday.**

**14. Friday.**

**15. Saturday.**

“TEXTILE MERCURY” ANNUALS—

---

JANUARY, 1910.

16. Sunday.

17. Monday.

18. Tuesday.

19. Wednesday.

20. Thursday.

21. Friday.

22. Saturday.

# DIARY, 1910

---

**JANUARY, 1910.**

**23. Sunday.**

**24. Monday.**

**25. Tuesday.**

**26. Wednesday.**

**27. Thursday.**

**28. Friday.**

**29. Saturday.**

**"TEXTILE MERCURY" ANNUALS--**

---

**JANUARY, 1910.**

**30. Sunday.**

**31. Monday.**

**FEBRUARY, 1910.**

**1. Tuesday.**

**2. Wednesday.**

**3. Thursday.**

**4. Friday.**

**5. Saturday.**

# DIARY, 1910

---

## FEBRUARY, 1910.

6. Sunday.

7. Monday.

8. Tuesday.

Shrove Tuesday. Half Quarter Day.

9. Wednesday.

Ash Wednesday.

10. Thursday.

11. Friday.

12. Saturday.

FEBRUARY, 1910.

13. Sunday.

14. Monday.

15. Tuesday.

16. Wednesday.

17. Thursday.

18. Friday.

19. Saturday.

# DIARY, 1910

---

## FEBRUARY, 1910.

20. Sunday.

21. Monday.

22. Tuesday.

23. Wednesday.

24. Thursday.

25. Friday.

26. Saturday.

“TEXTILE MERCURY” ANNUALS—

---

**FEBRUARY, 1910.**

27. Sunday.

28. Monday.

**MARCH, 1910.**

1. Tuesday.

2. Wednesday.

3. Thursday.

4. Friday.

5. Saturday.



# DIARY, 1910

---

MARCH, 1910.

6. Sunday.

7. Monday.

8. Tuesday.

9. Wednesday.

10. Thursday.

11. Friday.

12. Saturday.

“TEXTILE MERCURY” ANNUALS—

---

**MARCH, 1910.**

13. **Sunday.**

14. **Monday.**

15. **Tuesday.**

16. **Wednesday.**

17. **Thursday.**

St. Patrick. Bank Holiday (Ireland).

18. **Friday.**

19. **Saturday.**

# DIARY, 1910

---

MARCH, 1910.

20. Sunday.

21. Monday.

22. Tuesday.

23. Wednesday.  
Hilary Sittings end.

24. Thursday.

25. Friday.  
Lady Day. Good Friday.

26. Saturday.

"TEXTILE MERCURY" ANNUALS—

---

MARCH, 1910.

27. **Sunday.**

Easter Day.

28. **Monday.**

Easter Monday. Bank Holiday.

29. **Tuesday.**

30. **Wednesday.**

31. **Thursday.**

APRIL, 1910.

1. **Friday.**

2. **Saturday.**

# DIARY, 1910

---

APRIL, 1910.

3. **Sunday.**

4. **Monday.**

5. **Tuesday.**

Dividends due. Easter Sitzings begin.

6. **Wednesday.**

7. **Thursday**

8. **Friday.**

9. **Saturday.**

Lady Day Fire Insurance ceases.

“TEXTILE MERCURY” ANNUALS—

---

APRIL, 1910.

10. Sunday.

11. Monday.

12. Tuesday.

13. Wednesday.

14. Thursday.

15. Friday

16. Saturday.

DIARY, 1910

---

APRIL, 1910.

17. Sunday.

18. Monday.

19. Tuesday.

20. Wednesday.

21. Thursday.

22. Friday.

23. Saturday.

“TEXTILE MERCURY” ANNUALS—

---

APRIL, 1910.

24. Sunday.

25. Monday.

26. Tuesday.

27. Wednesday.

28. Thursday.

29. Friday.

30. Saturday.



# DIARY, 1910

---

MAY, 1910.

1. **Sunday.**

2. **Monday.**  
Bank Holiday (Scotland).

3. **Tuesday.**

4. **Wednesday.**

5. **Thursday.**

6. **Friday.**

7. **Saturday.**

“TEXTILE MERCURY” ANNUALS—

---

MAY, 1910.

8. Sunday.

9. Monday.

Half Quarter Day.

10. Tuesday.

11. Wednesday

12. Thursday.

13. Friday.

14. Saturday.

# DIARY, 1910

---

MAY, 1910.

15. **Sunday.**

Whitsun Day.

16. **Monday**

Whit Monday. Bank Holiday.

17. **Tuesday.**

18. **Wednesday.**

19. **Thursday.**

20. **Friday.**

21. **Saturday**

“TEXTILE MERCURY” ANNUALS--

---

MAY, 1910.

22. Sunday.

23. Monday.

24. Tuesday.  
Trinity Sittings begin.

25. Wednesday.

26. Thursday.

27. Friday.

28. Saturday.

# DIARY, 1910

---

MAY, 1910.

29. Sunday.

30. Monday.

31. Tuesday.

JUNE, 1910.

1. Wednesday.

2. Thursday.

3. Friday.

4. Saturday.

JUNE, 1910.

5. Sunday.

6. Monday.

7. Tuesday.

8. Wednesday

9. Thursday.

10. Friday.

11. Saturday.

# DIARY, 1910

---

JUNE, 1910.

12. Sunday.

13. Monday.

14. Tuesday.

15. Wednesday.

16. Thursday.

17. Friday.

18. Saturday.

“TEXTILE MERCURY” ANNUALS—

---

JUNE, 1910.

19. Sunday.

20. Monday.

21. Tuesday.

22. Wednesday.  
Longest Day.

23. Thursday.

24. Friday.  
Midsummer Day.

25. Saturday.



# DIARY, 1910

---

**JUNE, 1910.**

26. **Sunday.**

27. **Monday.**

28. **Tuesday.**

29. **Wednesday.**

30. **Thursday.**

**JULY, 1910.**

1. **Friday.**

2. **Saturday.**

“TEXTILE MERCURY” ANNUALS—

---

JULY 1910.

3. **Sunday.**

4. **Monday.**

5. **Tuesday.**  
Dividends due.

6. **Wednesday.**

7. **Thursday**

8. **Friday.**

9. **Saturday.**  
Midsummer Fire Insurance ceases.

# DIARY, 1910

---

**JULY 1910.**

10. Sunday.

11. Monday.

12. Tuesday.

13. Wednesday.

14. Thursday.

15. Friday

16. Saturday

“TEXTILE MERCURY” ANNUALS—

---

JULY 1910.

17. Sunday.

18. Monday.

19. Tuesday.

20. Wednesday.

21. Thursday.

22. Friday.

23. Saturday.

DIARY, 1910

---

JULY 1910.

24. Sunday.

25. Monday.

26. Tuesday.

27. Wednesday.

28. Thursday.

29. Friday.

30. Saturday

"TEXTILE MERCURY" ANNUALS—

---

JULY 1910.

31. Sunday.

AUGUST, 1910.

1. Monday.

Bank Holiday.

2. Tuesday.

3. Wednesday.

4. Thursday.

5. Friday.

6. Saturday.

DIARY, 1910

---

AUGUST, 1910.

7. Sunday.

8. Monday.

9. Tuesday.

10. Wednesday.

11. Thursday.  
Half Quarter Day.

12. Friday.

13. Saturday.

“TEXTILE MERCURY” ANNUALS—

---

AUGUST, 1910.

14. Sunday.

15. Monday

16. Tuesday.

17. Wednesday.

18. Thursday.

19. Friday.

20. Saturday.



DIARY, 1910

---

AUGUST, 1910.

21. Sunday.

22. Monday.

23. Tuesday.

24. Wednesday.

25. Thursday.

26. Friday.

27. Saturday.

“TEXTILE MERCURY” ANNUALS—

---

**AUGUST, 1910.**

28. **Sunday.**

29. **Monday.**

30. **Tuesday.**

31. **Wednesday.**

**SEPTEMBER, 1910.**

1. **Thursday.**

2. **Friday.**

3. **Saturday.**

# DIARY, 1910

---

SEPTEMBER, 1910.

4. **Sunday.**

5. **Monday.**

6. **Tuesday.**  
Ramadân begins.

7. **Wednesday.**

8. **Thursday.**

9. **Friday.**

10. **Saturday.**

“TEXTILE MERCURY” ANNUALS—

---

SEPTEMBER, 1910.

11. Sunday.

12. Monday.

13. Tuesday.

14. Wednesday.

15. Thursday.

16. Friday.

17. Saturday.

# DIARY, 1910

---

## SEPTEMBER, 1910.

18. **Sunday.**

19. **Monday.**

20. **Tuesday.**

21. **Wednesday.**

22. **Thursday.**

23. **Friday.**

Autumnal Equinox.

24. **Saturday.**

“TEXTILE MERCURY” ANNUALS—

---

SEPTEMBER, 1910.

25. Sunday.

26. Monday.

27. Tuesday.

28. Wednesday.

29. Thursday.  
Michaelmas Day.

30. Friday.

OCTOBER, 1910.

1. Saturday.

DIARY, 1910

---

OCTOBER, 1910.

2. **Sunday.**

3. **Monday.**

4. **Tuesday.**

Jewish Year 5671 begins.

5. **Wednesday.**

Dividends due.

6. **Thursday.**

7. **Friday.**

8. **Saturday.**

"TEXTILE MERCURY" ANNUALS—

---

OCTOBER 1910.

9. Sunday.

10. Monday.

11. Tuesday.

12. Wednesday.

13. Thursday.

Mich. Sitting - begin.

14. Friday.

Mich. Fire Insurance ceases.

15. Saturday.



DIARY, 1910

---

OCTOBER, 1910.

16. Sunday.

17. Monday.

18. Tuesday.

19. Wednesday.

20. Thursday.

21. Friday.

22. Saturday.

**"TEXTILE MERCURY" ANNUALS—**

---

**OCTOBER, 1910.**

23. **Sunday.**

24. **Monday.**

25. **Tuesday.**

26. **Wednesday.**

27. **Thursday.**

28. **Friday.**

29. **Saturday.**

DIARY, 1910

---

OCTOBER, 1910.

30. Sunday.

31. Monday.

NOVEMBER, 1910.

1. Tuesday.

2. Wednesday

3. Thursday.

4. Friday.

5. Saturday.

"TEXTILE MERCURY" ANNUALS—

---

NOVEMBER, 1910.

6. Sunday.

7. Monday.

8. Tuesday.

9. Wednesday.

10. Thursday

11. Friday.

Half Quarter Day.

12. Saturday

DIARY, 1910

---

NOVEMBER, 1910.

13. Sunday.

14. Monday.

15. Tuesday

16. Wednesday.

17. Thursday

18. Friday.

19. Saturday.

“TEXTILE MERCURY” ANNUALS—

---

NOVEMBER, 1910.

20. Sunday.

21. Monday.

22. Tuesday.

23. Wednesday.

24. Thursday.

25. Friday.

26. Saturday.

# DIARY, 1910

---

## NOVEMBER, 1910.

27. **Sunday.**

28. **Monday.**

29. **Tuesday.**

30. **Wednesday.**

## DECEMBER, 1910.

1. **Thursday.**

2. **Friday.**

3. **Saturday.**

“TEXTILE MERCURY” ANNUALS—

---

DECEMBER, 1910.

4. Sunday.
5. Monday.
6. Tuesday.
7. Wednesday.
8. Thursday.
9. Friday.
10. Saturday.



DIARY, 1910

---

DECEMBER, 1910.

11. Sunday.

12. Monday.

13. Tuesday.

14. Wednesday.

15. Thursday.

16. Friday.

17. Saturday.

“TEXTILE MERCURY” ANNUALS—

---

DECEMBER, 1910.

18. **Sunday.**

19. **Monday.**

20. **Tuesday.**

21. **Wednesday.**

Mich. Sittings end.

22. **Thursday.**

Shortest Day.

23. **Friday.**

24. **Saturday.**

Christmas Eve.

# DIARY, 1910

---

## DECEMBER, 1910.

25. **Sunday.**  
Christmas Day.
26. **Monday.**  
Bank Holiday
27. **Tuesday.**
28. **Wednesday.**
29. **Thursday.**
30. **Friday.**
31. **Saturday.**  
New Year's Eve.

“TEXTILE MERCURY” ANNUALS—

---

MEMORANDA

---

# F. REDDAWAY & CO., Ltd.

PENDLETON, MANCHESTER.

SOLE MANUFACTURERS OF

## “CAMEL HAIR” BELTING



Upwards of 50,000,000 feet supplied  
to Users all over the World.

### “Camel” Brand Belting.

India Rubber Goods for Mechanical  
Purposes.  
Canvas Fire Hose and Appliances.

Tel. Address: “ANCHORAGE, MANCHESTER.”  
Telephone Nos. 5520 and 5521 City.

Registered Telegraphic Address:  
 "GLOBE, CASTLETON-LANCASHIRE."

Telephones:  
 287 Rochdale (2 lines).

# TWEEDALES & SMALLEY, LTD.

## CASTLETON,

NEAR MANCHESTER,

Makers of

**MACHINERY FOR**

**PREPARING, SPINNING, and**  
**DOUBLING COTTON, etc. ::**

Royal Exchange, Manchester, Tuesday and Friday, Pillar No. 14.

### FOREIGN AGENTS.

Mr. F. BERGHOEFER, Munchen-Gladbach, Germany: For Rhenish Prussia, Westphalia, North Germany, Holland, Belgium, Alsace, and Lorraine.

Messrs. E. GREYER & CO., 5, Blackfriars-street, Manchester; also at Rouen, Milan, Turin, and Oporto; For France, Italy, and Portugal.

Messrs. WHITE, CHILD, & BENEY, Ltd., 62 and 63, Queen-street, Cheapside, London, E.C.: also Mr. JOSE DURAN Y VENTOSA, Ronda de San Pedro, No. 44-Ento, Barcelona, and Vienna, 1 Hohenstaufengasse 12: For Spain, Silesia, Saxony, Austria, and Russia Poland.

Mr. ROBERT HIBBERT, 29, Margarethenstrasse, Basle: For South Germany and Switzerland.

Messrs. A. & F. HARVEY, Tuticora: For Southern India.

Messrs. ILBERT & CO., Shanghai: For China.

Mr. J. HERBERT DUNKERLEY, Bombay: For Northern India.

Messrs. The H. G. McKERROW CO., Ltd., Room 912, Broad Exchange Buildings, 88, Broad-street, Boston, U.S.A.: For United States and Canada.

Messrs. DANIEL FOXWELL & SON, 1, North Parade, Parsonage, Manchester: For Scandinavia and Finland, and the St. Petersburg District.

Messrs. J. G. ALEXEEFF & CO., Moscow: For the Moscow District.

Messrs. V. USLAENDER & CO., Rua 10 de Marco N. 60, Rio de Janeiro: For Rio de Janeiro, Sao Paulo, Minas Geraes, and Espirito Santo, Brazil.

Manchester  
Exchange,  
12 Pillar,  
Exchange Telephone:  
No. 17,275.

ALL DESCRIPTIONS OF  
**STENTERING MACHINES,**  
CLIPS OR PINS, for Plain or Elastic Finish.

Nat. Telephone, 598.

Telegraphic Address: "WHITELEY, HUDDERSFIELD."

**Wm Whiteley & Sons Ltd**

**LOCKWOOD,**

**HUDDERSFIELD.**

AND EVERY CLASS OF  
**Finishing Machinery.**  
**RETURN STEAM TRAP**  
For Returning  
Condensation  
to Boilers.



# TATTERSALL & HOLDSWORTH'S

GLOBE WORKS and STORES:

ENSCHEDÉ, Holland; BURNLEY, England; and GRONAU, Westphalia.

Makers of all kinds of

## MACHINERY

used in  
**Sizing, Dyeing,**  
**Washing,**  
**Finishing**  
and  
**Drying.**

Makers of all kinds of

**Tin,**  
**Copper**  
and  
**Brass**  
**Goods**



*Tattersall's Patent for Drying Steam Machines with One Solenoid.*

used in the

**TEXTILE TRADES,**

including

**Steam and Water Fittings,**  
**Taps, Valves, Pumps, Fans, &c.**



**THIES' PATENT DYEING and BLEACHING APPARATUS for Dyeing and Bleaching the Yarn on Cops, Cheeses, and on the Backbeam, and in the Roving or Loose Cotton.**

**SPECIALITIES:**

**SIZE MIXING AND BOILING APPARATUS. SIZING MACHINES OF ALL KINDS, with the most recent improvements. DRYING MACHINES, Vertical and Horizontal. IMPROVED AIR DRYING MACHINES. Full boiler pressure can be used for heating the air. Water returned to the boiler easily. BALLING MACHINES for SIZED WARPS, also for UNSIZED WARPS. All kinds of VALVES, TAPS, AND GUN METAL FITTINGS. All kinds of PUMPS FOR SIZE AND WATER. CENTRIFUGAL PUMPS FOR WATER, ACID, OIL, &c. SPECIAL OIL PUMPS.**

**COPPER AND TIN DRYING CYLINDERS. TIN, COPPER AND BRASS GOODS used in Cotton, Woollen, Flax and Jute Mills, and Print and Dye Works.**

**SELF-LANDING CRANES.**

**PLANS AND ESTIMATES COMPLETE EQUIPMENT OF MILLS & WORKS.**  
submitted for the

The **“STOTT”**  
**Gas Bill Reducer**

For SPINNING MILLS & WEAVING SHEDS.

**15%**

TO

**40%**

**SAVINGS.**

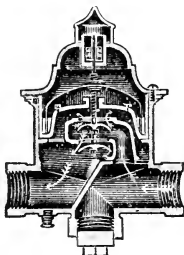

**15%**

TO

**40%**

**SAVINGS.**

Indispensable and specially made for  
 Incandescent Gas Lights.

**PRESERVES MANTLES & CHIMNEYS,**  
 and ensures a Uniform Light.

**J. STOTT & CO.**  
 Vernon Works, **OLDHAM.**

**“STOTT’S” PATENT SYSTEM**  
OF

# **DUST EXTRACTION**

**FROM CARDING ENGINES**

**During Stripping and Grinding.**

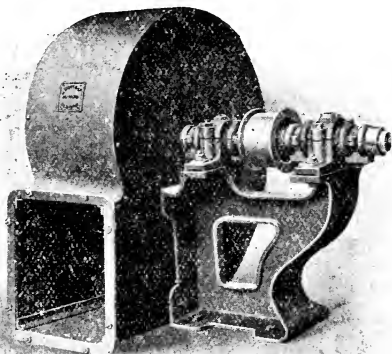

## **FANS & EXHAUSTERS**

**For Ventilating Spinning Rooms and buildings**  
**generally.**

**Ring Room Ventilating and Humidifying a speciality.**

---

# **J. STOTT & CO.**

**Vernon Works, OLDHAM.**

# GREENWOOD & BATLEY

LIMITED,

Albion Works, LEEDS.

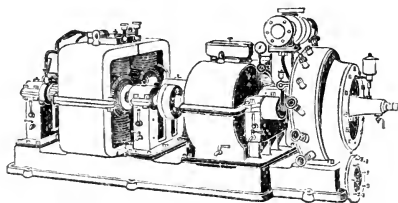

# STEAM TURBINES

For Direct or Electrical Driving  
of Cotton and other Mills.

---

COMPLETE ELECTRICAL INSTALLATIONS  
FOR POWER AND LIGHT.

**"THE" LAPPET**

(COOK'S PATENT).

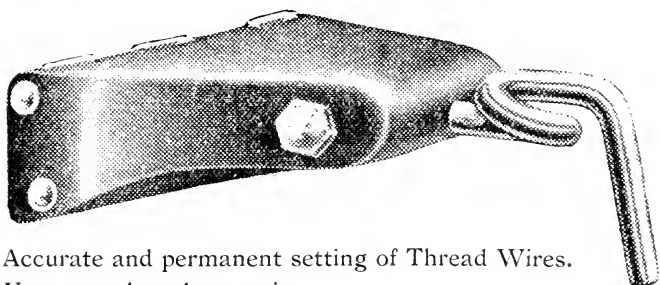
**SIMPLE! STRONG! SAFE!****Easy of Adjustment.****Impossible for piecers to tamper with setting.**

Accurate and permanent setting of Thread Wires.

No screw threads to strip.

Impossible to work loose.

One piece of steel, absolutely enclosed; thus preventing an accumulation of fluff and dirt, which invariably finds its way on to the yarn.

Perfectly smooth, impossible to damage bobbin tip, and—

**MADE TO LAST.****COOK & CO.****18, Exchange Street, MANCHESTER.****Works:—  
ALTRINCHAM.**

# GEO. HATTERSLEY & SONS, Ltd.

## KEIGHLEY.

Founded 1789.

Makers of every Description of  
**WEAVING AND PREPARING MACHINERY.**

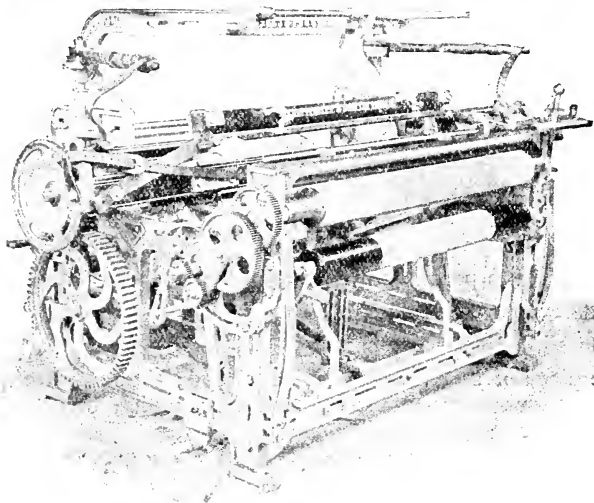

Original Inventors and Makers of the  
**DOBBY OR HEALD MACHINE.**

Automatic Reshuttling Looms.  
Mechanical Warp Stop Motions.  
Smallware Machinery.

# Robt. Broadbent & Son

MAKERS OF ALL KINDS OF LIMITED.

## WINDING . .

## MACHINERY

FOR

### Cotton, Silk, Wool, &c.

***SPECIALITY:—Quick Traverse  
Cross Winders, with either  
Conical or Parallel Drums.***

## PHOENIX IRON WORKS, Stalybridge

Telephone No. 296 Ashton-under-Lyne.

Telegrams: "BROADBENT, STALYBRIDGE."

Manchester Exchange, No. 10, Tuesdays.

Telegraphic Address: "CALENDER, BURY." Telephone No. 340.

# BENTLEY & JACKSON, Ltd.

**BURY, near Manchester.**

MAKERS OF

Bleaching, Finishing, and Calendering Machinery.

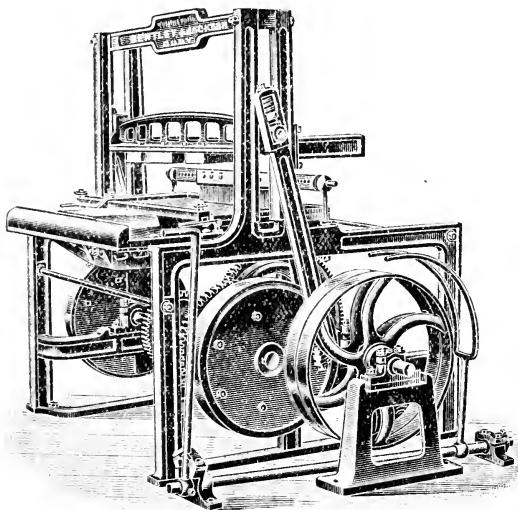

**STAMPING MACHINE FOR FOLDED PIECE GOODS.**

**SPECIALITIES.**—Complete Mercerising Plants. "Schreiner" Embossing Calenders. Glazing Calenders. Whitley's Patent Self-feeding Clip or Pin Stenters, for Plain and Elastic Finishes. Patent Stamping Machines, for Folded Piece Goods.

**Drying Cylinders with Spiral Emptying Buckets.**



---

# POLLIT & WIGZELL, LTD.

SOWERBY BRIDGE, England.

---

HIGH-CLASS STEAM  
**ENGINES**

---

ANY TYPE OF VALVES & GEAR.

12 I.H.P. FOR ONE PENNY PER HOUR.

---

**SHAFTING,**

**PULLEYS,**

**GEAR WHEELS,**

And Every Description of Millwright Work.

---

**STEAM AND WATER PIPES.**

---

Telephone No. 523 Halifax.

Telegraphic Address: "PROW, SOWERBY BRIDGE."

Codes: ABC (5th Edition).

Engineering Telegraph.

# SCOTT & HODGSON, Ltd. Engineers,

GUIDE BRIDGE, nr. Manchester.

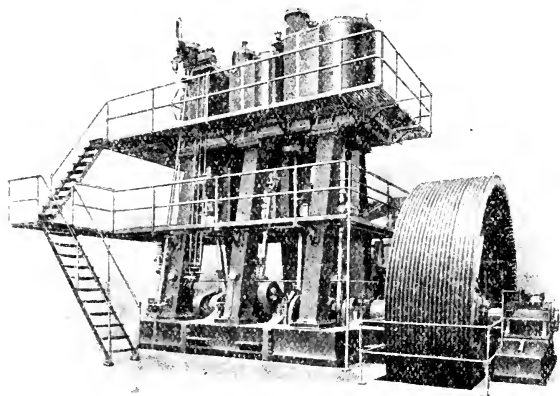

**INVERTED VERTICAL TRIPLE EXPANSION ENGINES,**  
700 I.H.P. in course of erection.

Cylinders, 15½, 25½, and 42 in. diam., by 3 ft. 6 in. stroke, to  
run 80 revs. per minute. Boiler Pressure, 180 lbs.

**SPUR-CUT GEARING** up to 26 ft. Diam., any Pitch,  
in Iron or Steel.

**STEAM ENGINES:** Beam, Horizontal, or Vertical, up to  
3,000 h.p., Compound or Triple Expansion.

**MACHINE MOULDED SPUR OR BEVEL WHEELS.**

**BLOWING ENGINES** up to 100 in. Bore Air Cylinder,  
any Type of Valve.

**ROPE OR BELT PULLEYS AND MILL GEARING.**

# JOSEPH STUBBS,

MILL STREET WORKS,

Branch Works:  
OPENSHAW.

Ancoats, MANCHESTER.

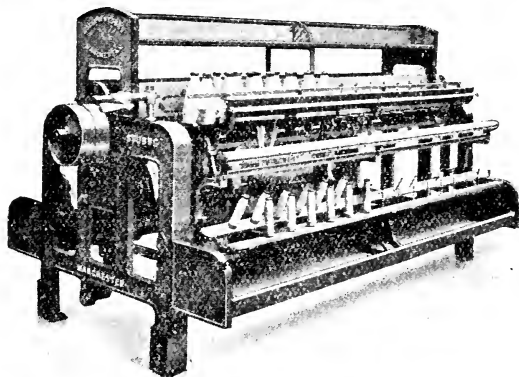

(Rabbeth Spindle Winder for Single Flanged Bobbins.)

## SPECIAL MACHINERY

FOR

**Winding, Doubling, Clearing, Gassing, Reeling,  
Preparing, Polishing, and Bundling Yarns, &c.**

NOTE:—The above machines (newest construction) may be seen  
in operation in Show Room at Mill Street Works.

**High-class Castings** Ordinary, Soft,  
and Annealed.

Manchester Exchange, No. 12 Pillar, Tuesdays and Fridays.

Telephones: { Ancoats Works, No. 4240 City (2 Lines).  
                  { Openshaw Works, Nos. 4740 and 5342.

Telegrams: "Winding, Manchester."

# GEORGE ORME & Co.

(Branch of Meters, Ltd.),

ATLAS METER WORKS,

Tel. Address: "ORME, OLDHAM."

Telephone No. 93.

## OLDHAM.

ORME'S

## **PATENT INDICATORS**

Of all descriptions for the Textile and Allied Trades.

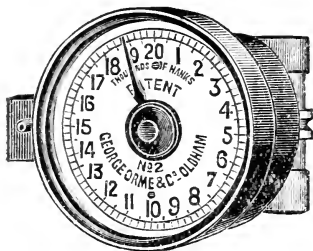

No. 2.—For Registering the number of Hanks Spun by the Self-acting Mule, Fixed upon the Back-shaft.

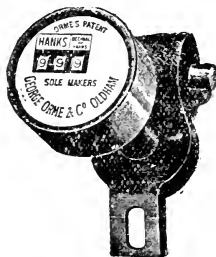

No. 6A.—For Roving Drawing Ring Frames, etc., Registers Hanks and Decimal parts of Hanks.

### **STRONG AND RELIABLE.**

No Springs or other complicated parts to get out of order.

We shall be pleased to receive your enquiries.

# PACKING

FOR STEAM ENGINES.

TRIED BY ANY TEST,

## United States Metallic Packings

ARE FOUND TO BE THE

**PREMIER METALLIC PACKINGS**

OF THE WORLD.

They embody the best of everything.  
**Design. Material. Workmanship.**

They **INCREASE THE EFFICIENCY** of the Engine  
 by **DECREASING THE FRICTION.**

Over **10** per cent. saving has been shown.

They are **DURABLE.** Some have given 27 years' service  
 without renewal.

They are the most extensively used Automatic Self-adjusting  
 Metallic Packings in the world.

Over **200,000** supplied.

Largely used in Textile Factories throughout Europe.

**HIGHEST AWARDS PARIS, 1900.**

## United States Metallic Packing Co. Ltd.

**Soho Works, BRADFORD.**

Also

London, Liverpool, Bolton, Glasgow, Swansea, Belfast,  
 Hull, Birmingham, Nottingham, Sheffield, &c.

**PAPER  
TUBES  
AND  
BOBBINS.**

---

**PATENT TUBING APPARATUS.**

---

Established 1859.

**JOHN SWAILES & SONS, Ltd.**  
**MOORHEY,**  
**OLDHAM.**

Telephone No. 42, Oldham.      Telegrams: "TUBERY, OLDHAM."

Bradford Exchange: Mondays and Thursdays.

Manchester Royal Exchange: No. 10 Pillar, Daily, Box 269.

Telegrams: "Hirnant, Manchester."

Telephone 956 Central.

# THOMAS LARMUTH & CO.

LIMITED,

SPECIALISTS IN MACHINERY.

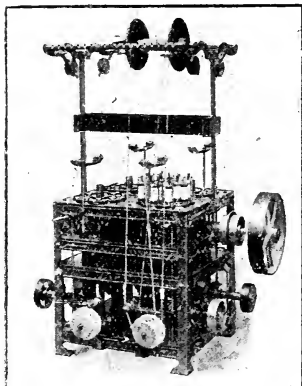

**Tubular,  
Twisted, and  
Loop  
Banding and  
Balling  
Machinery.**

**Tubular Banding Machine.**

Also **COMPLETE PLANTS** for the Manufacture of Asbestos, Braid, Baling, Candle Wick, Cable (Electric), Cords, Engine Packing, Flax, Hemp, Lamp Wick, Lace, Leather Belting, Oakum, Pickers, Reeds, Ribbons, Ropes, Smallwares, Tow, Twine, Thread, Winding, Warping, Yarn Polishing, etc., etc.

**CHAIN MAKERS** (all kinds).

**HAND & ELECTRIC CRANES.**

**ALPARGATA, OR ROPE SOLE SHOE MACHINERY.**

Works:

**Cross Lane, Salford, Manchester**

Practical Experience in Weaving and Loom Making for over **40** years.  
Medal and Diploma, Paris Exhibition, 1878; London, 1885.

# HENRY LIVESEY, Ltd.

**BLACKBURN,**

## MAKERS OF LOOMS

For Weaving Printers, Shirtings, T-Cloths,  
Domestics, Dhooties, &c.

## NORTHROP AUTOMATIC LOOMS.

### DROP-BOX LOOMS

of various kinds for GINGHAMS, HANDKERCHIEFS, etc.

ALSO LINEN AND SILK LOOMS.

Sole Makers of  
WINDING, WARPING, and  
INSPECTING MACHINES  
on the  
American System.

HYDRAULIC  
CLOTH PRESSERS, etc.  
PLAITING MACHINES.

LOOMING and  
DRAWING-IN FRAMES, &c.

L. & Y. DOBBIES from entirely New Patterns.  
"SLASHER" SIZING AND WARPING MACHINES.  
COP AND RING WINDING MACHINES.

Estimates for every description of Weaving Machinery.  
Illustrated Catalogues on application.



Manchester Royal Exchange, No. 10 Pillar,  
Tuesday and Friday, 2 to 3.

Telephone No.  
**2649.**

# JAMES MCMURDO,

MANUFACTURER OF

SINGLE, DOUBLE-LIFT

and DOUBLE

JACQUARD

MACHINES,

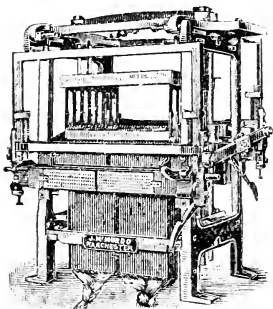

400'S DOUBLE-LIFT DOUBLE-CYLINDER  
JACQUARD MACHINE.

Piano Reading-in and  
Cutting Machines,

Repeating Machines and Stamping Plates  
suitable for working by Hand or Power,

Lead and Iron Wire Linges,

Brass and Steel Mails, Thread, Cards, Hooks and  
Needles, Comberboards and Slips, and all  
kinds of Jacquard Sundries.

Wooden Frame Jacquard Machines for Hand Looms.

SELF-ACTING REPEATING MACHINE.

Automatic Peg and Lace Hole Cutting Machine.

HARNESS BUILDER, &c.

New St., MILES PLATTING, MANCHESTER.

# BRITISH HUMIDIFIER CO.

## BLACKBURN. LIMITED,

SPECIALISTS IN MOISTENING & CONDITIONING  
MACHINES FOR TEXTILE FACTORIES.

### Our Patent Warp Moisteners

for Cotton and Worsted Looms apply the necessary moisture **only where it is required**, viz. :

On the Warp Threads as they leave the Beam.

#### RESULTS—

**More and Better Cloth.**

**A Large Saving in the Quantity of Twist.**

**Better Weaving Conditions.**

**Specialities** Oil Distributing Machines for Gill Boxes;  
for the Willow Machines, and  
**WOOLLEN TRADE.** Water Spraying Apparatus for Winding  
and Warping Machines.

Our Oil or Water Spraying Machines give a constant supply, and are easily and quickly adjusted to deliver a light or heavy spray.

Every Cotton or Woollen Manufacturer needs

## Conditioning Machinery.

Therefore try ours, **it is the Best and Cheapest.**

*Send us your enquiries, when we will be pleased to forward you full particulars of our system.*

**6, Duke Street, BLACKBURN.**

# PHILIPSON'S PATENT FLAT (Stripping) BRUSHES

(For Revolving Flat Carding Engines),

**ARE USED THE WORLD OVER.**

They have no equal. They are acknowledged to be the most **PERFECT FLAT STRIPPING** appliance on the **MARKET**; over

**50,000**

in **USE** at **HOME** and **ABROAD.**

When ordering **NEW CARDS** simply specify  
**Philipson's Brushes.**

We shall be pleased to furnish any information respecting the working of **PHILIPSON'S BRUSHES.**

*N.B.—Don't Re-bristle Old Brushes.*

**Sole  
Makers:**

**PHILIPSON & CO.**

**Works:**

**Holland Street, Astley Bridge,  
BOLTON.**

**Telegrams:**

**"SAFETY, BOLTON."**

**Royal Exchange,**

**Tuesday and Friday, Pillar No. 16.**

Telegraphic Address:  
"KEIGHLEY, BURNLEY."

Established 1853. A B C, A B C 5th Edition,  
Lieber's.

# GEORGE KEIGHLEY, Ltd.

## BURNLEY,

Makers of **Weaving & Preparation Machinery**  
High-class

With all Latest Improvements,

**IRONFOUNDERS and MILLWRIGHTS.**

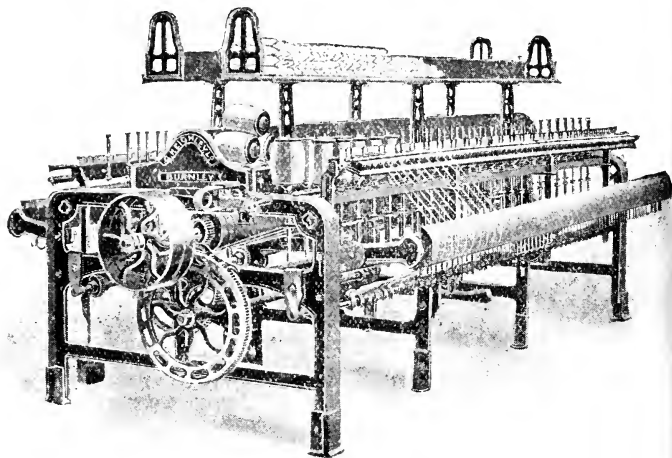

### COP WINDING FRAME.

Looms for all classes of Calicoes—Light, Medium and Heavy  
Cloths. Drop-Box, Circular-Box, Dobby and Jacquard Looms.

**Winding, Warping, and Slasher Sizing Machines.**  
**Size-Mixing Apparatus. Cloth Folding Machines.**  
**Hydraulic Piece Presses.**

Pirn Winding, Drum Winding, Sectional Warping, and Winding-off Machines  
**PATENT**

## **AUTOMATIC SHUTTLE-CHANGING LOOMS.**

The Simplest Loom yet invented.

40in. Reed Space Loom will work at 200 Picks per minute.

# POWER TRANSMISSION IN COTTON MILLS

High Efficiency insured  
by using

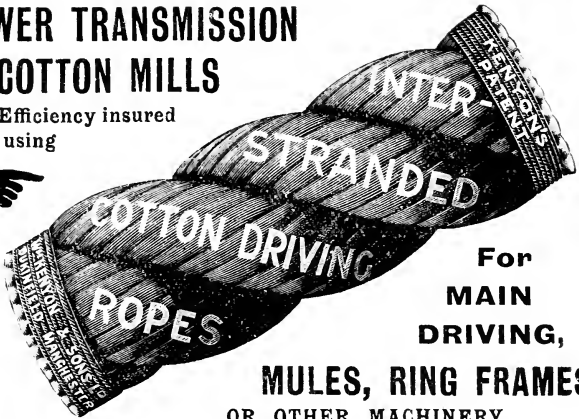

For  
MAIN  
DRIVING,  
MULES, RING FRAMES  
OR OTHER MACHINERY.

“ Illustrated Lecture on the Transmission of Power by Ropes.”  
Post Free.

MILL BANDINGS, TWINES, &c.

BOILER COVERING DEPARTMENT.

KENYON'S

Specially Compounded

“KISOL” (Reg.) CEMENT

A Most Effective Insulator Against Heat Radiation.

1 cwt. Sample Bag sent Carriage Paid to any address in the United Kingdom for 7s. 6d.

SILICATE COTTON, ASBESTOS, MAGNESIA, AND OTHER  
INSULATING MATERIALS.



Sheet Metal Work for Cylinder Casings, Flange Covers, &c.  
Ask for “HINTS” on the Covering of Steam Pipes, Boilers, &c.

**WILLIAM KENYON & SONS, LTD.**

Chapel Field Works, DUKINFIELD,

nr. Manchester.

Telegrams: “Kenyon, Dukinfield.”  
Telephone No. 494 Ashton.

ESTABLISHED 1838.

**THOMAS MOSCROP & CO., LTD.**

Oil and Tallow Refiners, Drysalters, &amp;c.

*Sago Flour, Farina, French Chalk, China Clay, Epsom Salts, Barytes,  
Mineral and Starch Importers.***GLUCOSE, GREASE, CHLORIDE OF MAGNESIUM, CHLORIDE OF ZINC,  
PARAFFIN AND WHITE WAX, AND SIZING INGREDIENTS.**White and Red Lead, Paint, Varnish, Oil, Color, Cement, Plaster,  
Whiting, Gum, Glue, Gelatine and Shellac Merchants;  
Oil for Leather Belting, &c.; Motor Spirits, &c.**BOILER ANTI-INCRUSTATION COMPOSITION  
AND CHEMICAL MANUFACTURERS.****"DREADNOUGHT" DISINFECTING FLUID.****1 & 3, FOLDS ROAD, BOLTON.**

Works:—St. George's Street, Bolton.

Manchester Royal Exchange, Box 16; Tuesdays and Fridays, 14 Pillar.  
National Telephone No. 116 (two lines). Tel. Address. "Drysalter, Bolton"

ESTABLISHED 1876.

Telephone 253.

**Wm. Holgate & Sons (Oldham), Ltd.**

MAKERS OF ALL KINDS OF

**PAPER COP TUBES, BRASS  
AND WIRE SPINDLE RINGS,****Phoenix Cop Tube Works, Little Moor Lane, OLDHAM****Sole Makers of MORRIS'S PATENT TUBING APPARATUS for  
Placing Tubes on the Spindles of Mules, Twiners, &c.**

Attends Manchester Exchange, No. 4 Pillar TUESDAYS AND FRIDAYS.

# Portable Tachometers

## For SPEED-TESTING

(of Frames, Spindles, Engines,  
Dynamos,  
Motors, Shafting, &c.)

With our Tachometers you have  
**No Wearisome Timing.**  
**No Calculating.**  
**No Trouble or Wasted Time.**

Revolutions per minute seen at  
a glance, and on the instant of  
contact being made.

**All Sizes. All Types. All Prices.**

### ALSO Thomas Standard Yarn Assorting Balance

For ascertaining counts of yarn  
from very small bits of cloth or  
short lengths of yarn... **Price 30/-**

For further particulars, circulars,  
etc., please apply to—

## GEO. THOMAS & CO.,

Parsonage Lane, Deansgate (60),

### MANCHESTER.

Tel. Address: "Samoth, Manchester."  
Telephone No. 1183.

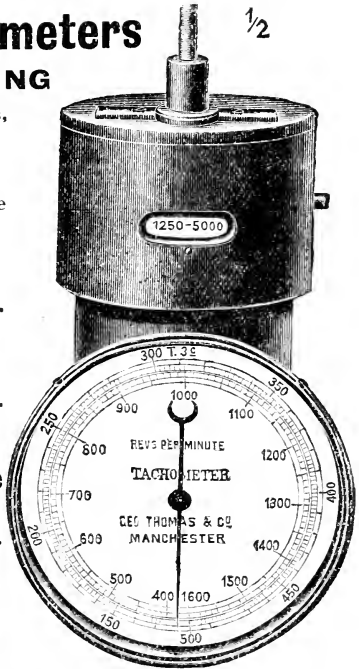

## SPLIT MOTIONS No Friction on Split Ends

(IMPROVED PATENT).

Temples, Springs, and Loom Requisites.

**J. FAIRBURN, Queen Street Mill,  
BURNLEY, Lancs., ENG.**

Established 1864.

# LUPTON BROS. LTD., ACCRINGTON

(INCORPORATING JAS. BLEZARD & SONS, PADIHAM).

Established 1869.

Patent "Revolveze" Ball-Bearing True Temple,  
for Flat or Round Bars.



Trade Mark.

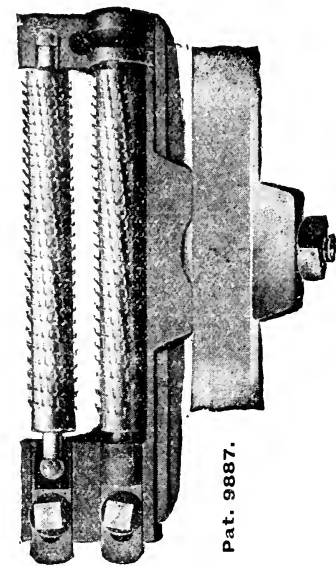

Pat. 9887.

**PATENT**  **REVOLVEZE**

Non-Tearing Temples,  
with Open Bottoms,  
Ball Bearings, and

Patent Lined Rollers.

FOR STRONG, MEDIUM OR  
LIGHT CLOTHS.

These Temples do not mark thin goods.

**MAKERS OF** PATENT RING and ROLLER TEMPLES, Trough  
and Roller Temples, Rollers, Springs, Spindles, Perforated  
Strip, Loom Accessories, etc.

 SEND FOR CATALOGUES. 



---

**BORE HOLES,**  
**WELLS,**  
AND  
**PUMPS,**  
ARE  
OUR SPECIALITIES.

---

**William A. Matthews & Co.**

**WELL ENGINEERS,**

**MOSTON LANE, MANCHESTER.**

Telephone No.  
87 (Cheetham Hill).

Telegrams:  
"BORING, MANCHESTER."

---

**“PERFECTION”**

# STEEL THREAD RAIL

**With Hardened Thread Wires**

*(TYTLER & BOWKER'S PATENT)*

**For SPINNING and DOUBLING FRAMES.**

---

Absolutely Accurate Setting of Thread  
Wire concentric with Spindle and  
Ring.

Prolonged Life of Rings & Travellers.

Better Yarn.

Increased Production.

---

**OVER**  
**3,500,000**  
in use and on  
order.

---

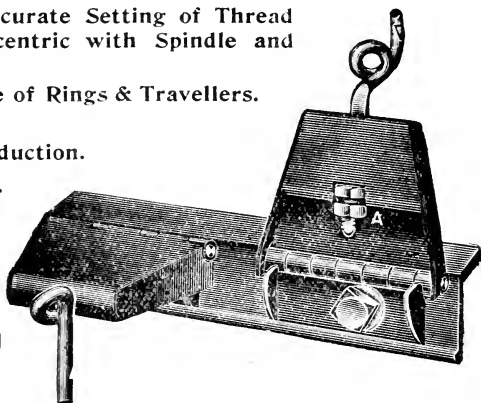

“A” Special Nut for adjustment of thread wire.

**The ONLY Thread Rail where the adjustment of thread wire and locking of same in position is done by ONE operation.**

**Thread Wires positively and firmly held, and cannot be altered or tampered with by work-hands.**

---

Supplied by all leading Textile Machinists.

# Roller and all Woollen Cloths.

**JAMES KENYON & SON, LTD.**  
 DERBY STREET MILLS,  
**BURY.**  
 T. A. KENYON, BURY.

**SECRET OF SUCCESS:  
 ADOPT MODERN METHODS.**

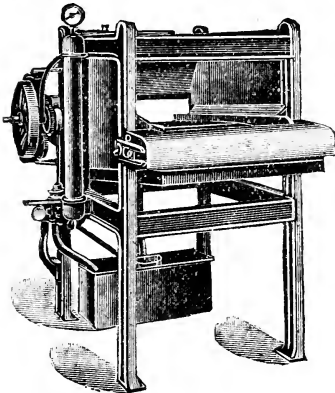

**WRAY'S**  
**Latest Model**  
**Automatic Cotton**  
**Yarn Setting and**  
**Conditioning**  
**Machine**

**For Hanks, Bunches,  
 Ring Bobbins, Cops,  
 &c.**

Patented at Home and Abroad.

For Price, Particulars, and permission to try the Machine, please write to

**G. & A. WRAY,**  
**Alexandra Shed, KEIGHLEY,**  
**England.**

Telephone No. 93 Y

---

THE TIT BIT OF  
**DUST REMOVING**  
FROM CARDS, IS THE  
**PIONEER**  
**AUTOMATIC**  
**SYSTEM.**

---

“What it is in a few words.”—

A Perfect Dust Remover without Extra Labour.

An Independent Exhaust System of Ventilation.

An Independent Cardroom Cleaner.

An Independent Cotton Waste Remover from  
Cardroom to Cellar.

---

FULL PARTICULARS APPLY:—

**The H. Smethurst Ventilating  
and Engineering Co., Ltd.**

**HOLLINWOOD,**

**MANCHESTER.**

# **WILLIAM BODDEN & SON, LTD.**

Spindle and Flyer Manufacturers and Machinists,

***Hargreaves Works, OLDHAM.***

## **SPINDLES AND FLYERS**

Of every description and with any kind of Presser  
for Cotton, Silk, Woollen, or Flax Spinning,

**Improved MULE SPINDLES for High Speeds.**

Speciality :—BODDEN'S IMPROVED

### **"ACME" RING SPINDLE, WITH PATENT INTERNAL OIL TUBE,**

Which entirely dispenses with necessity of stopping frame, taking out spindle or use of pumps when re-oiling, thus saving a great amount of oil, bands, time, and labour.

**4,000,000 Spindles with the above Patent at Work.**

**ALSO MAKERS OF ALL**

Ordinary and Elastic Rabbeth and other Ring Spindles.  
New Long and Short Collars.

Wheels, Steps, Brackets, Plain or Loose Boss Top Rollers.  
Patterns of every description for Lawson's Frames.

**RINGS OF ALL KINDS.**

**SLUBBING, INTERMEDIATE, ROVING and RING FRAMES  
RE-SPINDLED, REPAIRED, LINED UP,**

And put into thorough working order on our own Special  
Improved Methods.

**ESTIMATES GIVEN FOR ANY OF THE ABOVE.**

# SUTCLIFFE & SUTCLIFFE.

OUR WORKMANSHIP CANNOT BE SURPASSED.

<p>TELEPHONE 11158, 8, AVONDALE TELEGRAMS—"INTEGRITY"—MANCHESTER.</p>  <p>15 SUPPLIED TO H.M. GOVERNMENT</p> <p><b>SOME OF— SUTCLIFFE &amp; SUTCLIFFE'S MANUFACTURES &amp; SPECIALITIES</b></p>	<p><b>EXTRAORDINARY STRENGTH LION BELTING</b> DURABLE LIGHT &amp; PLIABLE</p> <p>APPLICATED TO ALL WELLS, BOILER BELLS, STEAM ENGINES, &amp; ALL KINDS OF MACHINERY.</p>	<p><b>ALWAYS SOFT &amp; SMOOTH LION LACES</b> THE BEST &amp; STRONGEST IN USE</p> <p>THESE LACES ARE MADE OF SUPERIOR Wool, and are of a superior quality, and are made in a special way, so that they are "SHOULDER THEM" AND WILL NOT "SHOULDER THEM"</p>	<p><b>ACQUAINTED VICROLITE</b> JACKING</p> <p>THIS IS THE BEST AND MOST EFFICIENT JACKING MATERIAL EVER INVENTED</p>	<p><b>EVERY FORM OF ASBESTOS</b> REDUCED PRICES</p> <p>QUALITY AND QUANTITY GUARANTEED</p>	<p><b>SUPERIOR ENAMELLED &amp; PLAIN GAUGE GLASSES</b> FOR METALS (HYDROSTATIC TESTING)</p> <p>MAKE STOCK &amp; TEST OF BOULDER BRASSING</p>	<p><b>CANNOT CUT GLASS FOR— GLASS CUTTING &amp; GLASS WORKING</b></p> <p>ALL OUR GLASS CUTTING &amp; GLASS WORKING IS DONE BY HAND</p>	<p><b>UNQUESTIONABLY THE BEST TELLURIC CEMENT</b> FOR COVERING BOULDER BRASSING</p> <p>TELLURIC CEMENT IS THE BEST FOR COVERING BOULDER BRASSING AND IS THE MOST DURABLE &amp; CHEAPEST MATERIAL AVAILABLE</p>	<p><b>PREVENTS CORROSION CLIMAX BOILER FLUID</b> EFFECTIVE ECONOMICAL</p> <p>PREVENTS CORROSION IN BOILERS AND THE SAFEST EFFECTIVE ECONOMICAL CORROSION PREVENTER</p>	<p><b>THE BEST WALKER IN THE INDUSTRY— VIVAX OIL—CANS</b> SAVES OIL PREVENTS LEAKAGE</p> <p>THE BEST WALKER IN THE INDUSTRY— INDIAN RUBBER BELT FREE &amp; BLENDED WITH PAPER SUITABLE FOR ALL PURPOSES</p>	<p><b>HARVESTING &amp; SUFFICIENT LENGTH IN FOOTING INDIAN RUBBER BELT</b> FREE &amp; BLENDED WITH PAPER SUITABLE FOR ALL PURPOSES</p>	<p><b>THE BEST WALKER IN THE INDUSTRY— VIVAX OIL—CANS</b> SAVES OIL PREVENTS LEAKAGE</p> <p>THE BEST WALKER IN THE INDUSTRY— INDIAN RUBBER BELT FREE &amp; BLENDED WITH PAPER SUITABLE FOR ALL PURPOSES</p>
--	--	---	--	--	--	--	--	--	---	--	---

ONLY THE VERY BEST MATERIALS USED AND

TEXAS WORKS, MANCHESTER, England.

# H. SCHIRP, BARMEN-U.

Textile Machinist.

Speciality since 1863:

# DYEING APPARATUS

For Hanks, Cheeses, Cops,  
and Loose Materials.

# RAG LAGS & TEETH For Opening COTTON WASTE.

REFERENCES AT SERVICE.

RESPECTFULLY SOLICITING A TRIAL WE AWAIT YOUR ESTEEMED COMMANDS

SUTCLIFFE & SUTCLIFFE,  
MANCHESTER, ENGLAND.

ESTABLISHED 1872.

Address Telegrams, "CORT Ltd., BLACKBURN."

Telephone Nos. 308 and 306a.

Manchester Royal Exchange, No. 11 Pillar,  
Tuesdays and Fridays.

Branch Warehouses—  
PHOENIX MILL KING STREET,  
& THROSTLE STREET BLACKBURN.  
All communications to Canterbury Street.

## Makers of Weavers & Warpers' Beams

with CAST IRON, MALLEABLE and STEEL FLANGES.

## Makers of IMPROVED METALLIC COVERED SHED RODS

For  
Cotton,  
Silk,  
Linen,  
Woolen,  
and  
Worsted  
Goods.



MADE TO ANY LENGTH



These  
are  
Wood  
Rods  
Covered  
with  
Tin.



SECTIONAL VIEW



## Second-Hand Cotton Spinning & Weaving Machinery

LOOM and DRIVING PULLEYS, HEALDS and REEDS, STRAPPING, SHAFTING, WROUGHT and CAST IRON PULLEYS, WEAVERS' and TAPERS' CHANGE WHEELS, WARPERS' and SPINNERS' BOBBINS, FLANGES, FITTINGS for Various Makes of LOOMS, and GENERAL, MILL STORES.

CASH BUYERS of Looms, Mules, Frames, Engines, Boilers, &c.

# **BROOKS & DOXEY,** **MANCHESTER.** LIMITED,

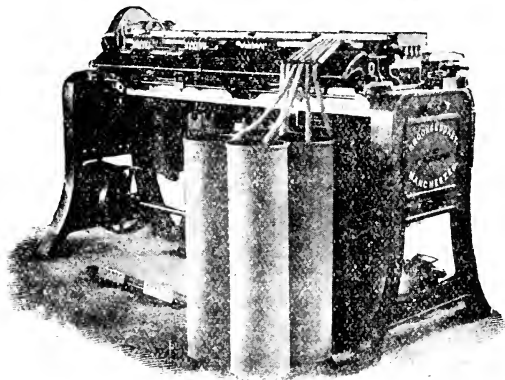

DRAWING FRAME, WITH PATENT STOP MOTIONS.

MAKERS OF

## **COMPLETE PLANT of COTTON SPINNING MACHINERY.**

ALSO OF

**Winding and Doubling Machinery.**

**Roving Waste Openers.**

**Thread Extractors.**

**Self-Acting Mules for Cotton Waste and Wool.**

**UNION IRON WORKS, WEST GORTON.**

**JUNCTION IRON WORKS, MILES PLATTING.**

**Town Office: 15, Market Street.**

*Telephone Nos.*  
**605 City (4 Lines).**

*Telegraphic Address:*  
**"UNION, Manchester."**



**Mercerising, Bleaching,  
Dyeing & Finishing Machinery  
For CLOTH, WARP, and HANK.**

SOLE MAKERS OF

**PATENT**

**SECTIONAL WARPING**

AND

**BEAMING MACHINES**

**FOLDING and  
MEASURING  
MACHINES**

with or without  
Rigging Arrangement.

**CHILLED**

**ROCKING BARS.**

THE MASUREL-LECLERCQ SIZING MACHINE.

**ESTABLISHED 1864.**

**Knowles & Co.**

***Textile Machinists,***

Telegrams:

"MACHINES, BRADFORD."

Telephone:

BRADFORD 931 & 932.

**GLOBE WORKS,  
BRADFORD**

# BRUSHES LIMITED

**JAMES WILDE & SON,**  
The "Kra" Brush Factory,  
Oldham, England.

Telegrams: "BRUSHES, OLDHAM."  
Telephone: 371, OLDHAM, England.

**THOMAS SHAW & SONS,**  
The "Globe" Brush Works,  
Ashton-under-Lyne, Eng.

Telegrams: "BRUSHES, ASHTON-U-LYNE."  
Telephone: 258, ASHTON-U-LYNE, Eng.

MAKERS OF ALL CLASSES OF

## Machine & Mill Brushes

For HOME and EXPORT.



**COMBER BRUSHES and STRIPPING BRUSHES**  
For Revolving Flat Cards RE-BRISTLED.

*Send a p.c. and we will send our Vans for your old brushes and re-deliver quickly.*

Ask for particulars of our New Improved **PATENT COMBER ENDS** and Sample **LEATHER STRIPS** for **RECOVERING R. F. CARD BRUSHES** at own Mill.

**Brushes for Calico Printers, Velvet Dyers, & Paper Makers.**

Mill Brooms	Roller Brushes	Grease Brushes
Mill Banisters	Whitewash do.	Grid do.
Comber do.	Winders' do.	Flyer do.
Incandescent do.	Spindle do.	Heald do.
Weed Brooms	Twiners' do.	Tiering do.
Paste Brushes	Shafting do.	Paint do.

SEND FOR ILLUSTRATED CATALOGUES & PRICES.

**WILLIAM H. COOK, M. I. Mech. E.**  
**TECHNICAL EXPERT and ARBITRATOR.**

Author of The Plain Series of Cotton Spinning Calculations.  
 Examiner in Cotton Spinning to the City and Guilds of London Institute.

**Plans prepared for New Mills; Old Mills re-arranged  
 at home or abroad.**

**MACHINERY AGENT. POWER INSTALLATIONS.** *Estimates given.*

**Stanley Grove, Longsight, MANCHESTER.**

**FIELDEN & CO.**

**Ainsworth St. Works, ROCHDALE.**

Washing, Drying, Ventilating, Dust Collecting,  
 Steam Removal, and Wool Conveying Engineers.

Telephone No. 119.

**EMMOTT & CO., Signal Works, STALYBRIDGE.**

Lubricants.  
 Wheel  
 Grease.  
 Boiler Fluid

ESTABD 1865  
**MAKERS OF ALL KINDS OF**  
**COVERINGS**  
**FOR BOILERS PIPES ETC.**  
 UN-EQUALLED  
**ECONOMY & DURABILITY**  
 ENQUIRY SOLICITED

FELT.  
 Silicate  
 Cotton.  
 Varnishes

**EMERY FILLETING.** Emery Rollers  
**Re-Covered.**

Card Grinding and Roller Covering Machines.

**COBDEN CHADWICK, Century Works, Honduras St., OLDHAM.**

**WILLIAM MOSS & SONS, Machinists**  
**Spindle and Flyer Manufacturers,**

General Repairers of Roving, Intermediate, Slubbing, Throstle  
 and Doubling Frames with Mason's Collars, Footsteps, Spindle and  
 Bobbin Wheels.

**Carrs Spindle Works, STOCKPORT.**

Telegrams: "Spindles, Stockport." ABC Codes, 4th and 5th Editions.  
 Nat. Telephone 39x. Exchange: 16 Pillar, Tuesday and Friday.

**PATENTS**

Telephone Nos.—Halifax, 90: Burnley, 909Y

OBTAINED BY

**TASKER & CROSSLEY,** Patent Agents,Imperial Chambers, George Square, HALIFAX; and  
2, Grimshaw Street, BURNLEY.

Established 1852. Designs and Trade Marks Registered.

Telegrams:

"GREENHALGH SONS,  
OLDHAM."Telephone:  
No. 195.**JOHN GREENHALGH & SONS**  
LIMITED,  
**OLDHAM.****Special WILLOW MAKERS.**

Established 60 Years.

**MARSDEN & Co. LTD.**

Engravers, Printers, &amp; Manufacturing Stationers,

ENGINEERS' CATALOGUES A SPECIALITY.

**TEXTILE MERCURY PRINTING WORKS,  
CARR STREET, MANCHESTER.**

# CHLORIDE OF ZINC

(LIQUID).

For Price, etc., apply to

**THE UNITED ALKALI CO., Ltd.**

30, JAMES STREET, LIVERPOOL.

# J.B. WEAVING REQUISITES

Healds (cotton, mail, wire), Reeds (usual and Soldat), Lags and Pegs, Shed Rods, Springs, Split Chains, &c.

**JONES BROS Ltd Blackburn.**

**FLUTED ROLLERS** for Spinning  
Machines.

TOP & BOTTOM ROLLERS for Doubling Frames, &c.

Repairs a Speciality.

**WM. LONGWORTH & SONS, Ltd.**

51, FOLDS ROAD, BOLTON.

*Estab. 1867. Telephone No. 402 Telegrams: "CYMRAES, Stockport."*

**JOHN ROBERTS & CO.**

**Welsh and Persian Roller Skins.**

Special Mule Belting, Butts, Picking Bands,  
Laces, &c.

52, Wellington Road North, STOCKPORT.

**SKIPS.** BEST QUALITY.  
Prompt Attention.

Telephone No. 313.

Telegrams: "ABBATT, BOLTON."

**WM. ABBATT & CO.,** ALBION  
CANE WORKS, BOLTON.

# LEATHER BELTING

SPECIAL QUALITY  
FOR  
CONE DRUMS.  
SINGLE AND DOUBLE  
LEATHER BELTING.

Specially Prepared for  
Home and Export Trade.

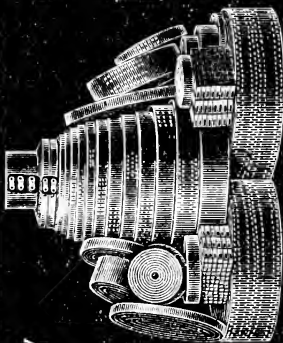

SPECIALITY

EXTRA STOUT  
OAK-TANNED

MULE STRAPPING

Acknowledged by Users  
to be the BEST in the Market.  
For Cotton Spinning

PRICES ON APPLICATION.

MANUFACTURED BY

## G. THOMPSON & SONS,

ESTABLISHED 1848.

TANNERS AND CURRIERS, SOWERBY BRIDGE, ENGLAND.  
STONE MILL TANNERY,

Telegraphic Address: "Leather, Sowerby Bridge,  
Airedale, Fourth Edition,  
Telephone No. 535.

Telegraphic Address: "LEATHER," SOWERBY BRIDGE.

# PORRITT BRO<sup>R</sup>. & AUSTIN,

STUBBINS VALE MILLS, LIMITED,  
RAMSBOTTOM, nr. Manchester.

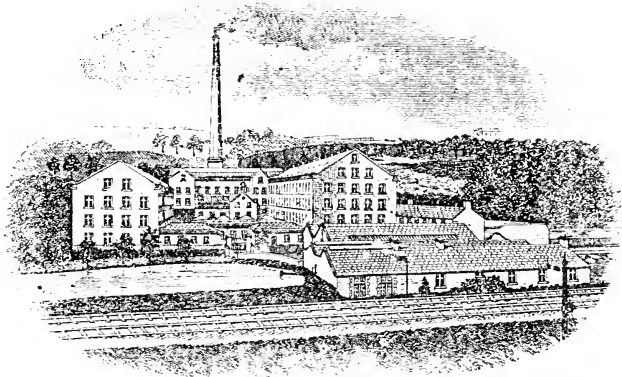

Manufacturers of

**SLASHERS' FLANNELS & WINDERS' CLOTHS.**

Washer and Scavenger Cloths.

EXTRA STOUT and IMPROVED SIZING CLOTHS  
for Ball Warp Sizing.

**Roller & Clearer Cloths.**

Blankets and Lappings for Calico Printers and Paper Stainers.  
Surface and other Sieve Cloths, Steaming and Table Blankets.

**LAUNDRY BLANKETS & FELTS.**

And every description of  
Woollen, Linen, and Cotton Cloths for Mechanical Purposes.

Telephone No. 100 Ramsbottom.

Telegraphic Address: "PORRITTS, Ramsbottom."

# WILLIAM SCHOFIELD,

**Maker of BOBBIN and COP REELS**

**For Throstle, Doubler or Ring Bobbins,**

**Cheeses, Bottle Bobbins, and Mule Cops**

(BY HAND OR POWER), WITH

Improved Long Sleeve Circular Doffing Motion to Prevent Greasing of Hanks whilst Doffing; Seven-Lea, Two-Lea, Crossing, Skeining, Spreading, Brake and Adjustable Wrap Wheel Motions, Automatic Motion to Register One, Two, Three, Four, or Five Hank Cross, Yarn Clearing Guides, etc. WINDING FRAMES with Heart or Mangle-wheel Motion for Hanks, Throstle or Ring Bobbins, and Cops. NOTON'S PATENT BALLOONING and SNARL PREVENTER, for Reeling or Winding Ring Yarn. ADJUSTABLE YARN CLEARERS, for Winding Frames. CIRCULAR WARPING MILLS, Specially Strong, for Long and Heavy Warps. WARPING HECKS.

---

**ROSE HILL WORKS, WATERHEAD, OLDHAM.**

Telephone—Works, 509; House, 509a.

Manchester Exchange, 10 Pillar, Tuesdays, 2-15 to 3-30 p.m.

---

**NOW READY. 2/6 NET, POST FREE.**

---

# The WOOL YEAR BOOK

**1910.**

Compiled by ALDRED F. BARKER (Bradford Technical College).

**UNIFORM IN STYLE AND AIM**

**WITH THE "COTTON YEAR BOOK."**

**MARSDEN & CO., LTD.**

**Publishers, CARR STREET, MANCHESTER.**



**Brass and Copper Tubes, Sheets, Wire, &c.  
Tin Plates, Block Tin, Zinc and Spelter,  
Pig Lead, Sulphate of Copper.**

**JAMES J. BENNETT,**  
88, Mosley Street, Manchester.

**"NEWTON" Automatic Sprinkler Installations**

Secure the Highest Rebates of Premium.

ESTIMATES FREE FROM

**NEWTON, CHAMBERS & CO. LTD.,**  
BROOK HOUSE, WALBROOK, E.C.,  
Also Manchester, Sheffield, Bombay, Shanghai, &c.

**"GRIPO" BELT DRESSING.**

Undoubtedly the best **Belt Adhesive** and **Preservative**  
on the market. Used by nearly 2,000 Mills and Works  
in Lancashire and Yorkshire alone.

SOLE MAKER—

**T. NOTON,** Grange Works, Glodwick Rd., OLDHAM.  
*Telephone No. 270.*

**Warpers' & Weavers' Beams**

Supplied either with or without Flanges.

**W. HENSHALL & SONS,**

Timber Merchants,

Tel. No. 245.

**BARKER STREET, OLDHAM.**

**ENGINEERING & MILLWRIGHTING**

**THOMAS WAINWRIGHT & SONS,**  
**STALYBRIDGE.**

*Telegrams: "Wainwrights, Engineers, Stalybridge." Telephone No. 128.*

THE  
**SCHAELLIBAUM GRIDS**

We are not only Makers of the Patent Schaellibaum Grids, but also of all kinds of Special Grids to suit wishes of Customers and existing conditions.

FREE TRIALS.

Many Lancashire References.

---

**THE ROB. SCHAEILLIBAUM CO.**  
(CHAS. D. DOYLE),  
**67, Hanging Ditch, Manchester.**  
Telephone No.: City 2538.

---

---

**HOLT & KIRK, Ltd.**  
**OLDHAM.**

---

MAKERS OF ALL KINDS OF

REELS AND BUNDLING PRESSES,  
HOPPER FEEDERS, COTTON OPENERS, AND  
SELF-ACTING WILLOWS,  
ROVING, WINDING AND MULE SPINDLES.  
TOP & BOTTOM MULE & FRAME ROLLERS.  
BOBBIN, SPINDLE & SKEW GEAR WHEELS.

# S. NOTON & SONS, Oldham

England.

Largest Makers  
in Europe of

**FIBRE CANS**

and other utensils  
for the

**Cotton, Silk, Wool, Worsted, Flax, Jute,  
and Rope Trades.** *Estab. 1877*

NEW PATENT SASH CORDS (Solid Braided). Loop Bands and Endless Blind Cords. Specialities: Ropes, Twines, **TUBULAR BANDINGS, SMALLWARES,** Picture and Blind Cords, Corset Laces, Log Lines, Trolley Cords, &c.,

**JOHN H. BLAKEY, Bridge Mills, RADCLIFFE, nr. Manchester.**

*Telegrams: "Blakey, Bridge Mills, Radcliffe." Telephone No. 71 Whitefield.  
Royal Exchange, No. 6 Pillar, Tuesday and Friday, 2 to 3 p.m.*

## SPRINGS & ACCESSORIES

FOR TEXTILE AND OTHER MACHINERY.

Best Quality and Finish.

**SAMUEL COOK & CO. ALBERT WORKS, BURY**

## B. ROBINSON & CO.

Bark Street Tin and Copper Works, BOLTON.

Also Starkie Street, Blackburn.

Steam Engine Cylinders covered with Planished Steel.

Continuous Lubricating for Bearings.

All kinds of Tin Work for Cotton Spinners and Machinists

Telephones: Bolton, 351; Blackburn, 104 x.

## THOS. WAREING & CO.

Grecian Emery Works, ROCHDALE.

Makers of EMERY, EMERY CLOTH,  
GRINDING FRAMES, EMERY ROLLERS.

**PATENT DIAGONAL GROOVED EMERY FILLETING.**

Manchester Exchange—Tuesdays & Fridays, 2 to 3, No. 12 Pillar.

The  
**Textile Mercury**

---

---

WEEKLY. ONE PENNY.

---

Illustrated Articles on the Latest Improvements  
in Machinery—every week.

---

The Up-to-date Textile Paper.  
Largest Circulation.

---

**BEST ADVERTISING MEDIUM.**

---

Order of your newsagent, or may be obtained post free  
for 6/6 per annum; or 12/- abroad.

---

**MARSDEN & CO., Ltd.**  
Carr Street, MANCHESTER.

MANUFACTURERS OF  
**MODERN HIGH-PRESSURE**  
 Standard Size  
**FUEL ECONOMISERS**

Saves 15 to 25 per cent. in Coal.

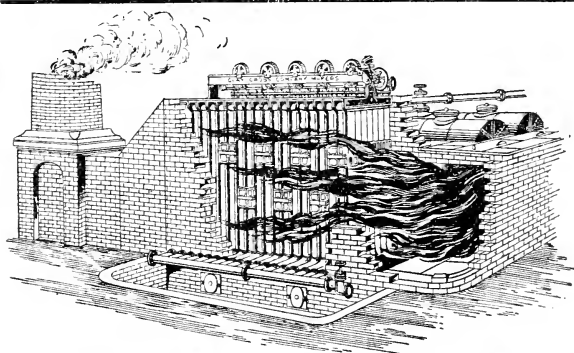

SUPPLIED TO STEAM USERS THROUGHOUT THE WORLD.

Awarded the only Gold Medal for Fuel Economisers  
 at the Franco-British Exhibition, 1908.

Nat. Telephone: 147, Chesterfield (2 Lines).

Telegrams: "JACKSON, CLAYCROSS."

Full Particulars on application—

**The Clay Cross Company,**

Near **CHESTERFIELD**

**CONTRACTORS TO H.M. GOVERNMENT.**

# WILLIAM TATHAM & CO

## Vulcan Works, ROCHDALE,

(Branch Works—BELFIELD, ROCHDALE.)

ENGLAND

Makers of Machinery for:—

Opening, Cleaning,

Breaking up,

Carding & Spinning

All Kinds of Cotton Waste.

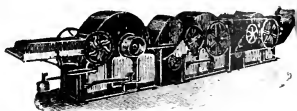

**SPONGE OR CLEANING CLOTH MACHINERY.**

**WADDING MACHINERY** of various kinds

Comprising Openers, Carding Engines, Folders,  
Sizing Machines, Drying Chambers, etc.

**ENGINE CLEANING or WIPING WASTE  
MAKING MACHINES.**

**WOOLLEN RAG or WASTE TEARING MACHINES.**

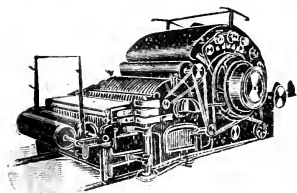

**Asbestos Machinery**

**Roving Waste**

**Opening Machines.**

**Slubbing, Intermediate,  
and Roving Frames [for  
Cotton, etc., etc.]**

**THREAD EXTRACTOR for Cotton Waste.**

515 SPECIAL COLL. TS1551.C6 1910

TS Cotton year book

6  
1910

SOUTHEASTERN MASSACHUSETTS UNIVERSITY



3 2922 00321 398 7

