

New York
State College of Agriculture
At Cornell University
Ithaca, N. Y.

Library

Cornell University Library
SF 263.M16 1922

Principles and practice of butter-making



3 1924 002 938 243

maan

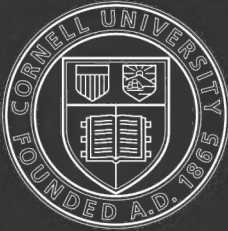

Cornell University Library

The original of this book is in
the Cornell University Library.

There are no known copyright restrictions in
the United States on the use of the text.

WORKS OF PROF. C. LARSEN

PUBLISHED BY

JOHN WILEY & SONS, Inc.

Exercises in Farm Dairying.

By C. Larsen, M.S.A. The Loose Leaf Laboratory Manual of The Wiley Technical Series, J. M. Jameson, Editor. An Elementary Manual for Agricultural High Schools and Colleges; a Practical Guide for Farmers and Dairymen. 4to, paper, \$1.00 net.

By McKAY AND LARSEN

Principles and Practice of Butter-making.

A Treatise on the Chemical and Physical Properties of Milk and its Components; the Handling of Milk and Cream, and the Manufacture of Butter Therefrom. By G. L. McKay, Secretary, American Association of Creamery Butter Manufacturers, formerly Professor of Dairying in the Iowa State College, Ames, Ia., and C. Larsen, M.S.A. Third Edition, Largely Rewritten. xiv + 405 pages, 6 by 9. 133 figures. Cloth, \$3.00 net.

By LARSEN AND WHITE

Dairy Technology.

A Treatise on the City Milk Supply, Milk as a Food, Ice Cream Making, By-Products of the Creamery and Cheesery, Fermented Milks, Condensed and Evaporated Milks, Milk Powder, Renovated Butter, and Oleomargarine. By C. Larsen, M.S.A., and Wm. White, B.S. xiii + 298 pages. 5½ by 8. 46 figures. Cloth, \$2.00 net.

PRINCIPLES AND PRACTICE
OF
BUTTER-MAKING

BY

G. L. MCKAY, DR.SC.

*Secretary, American Association of Creamery Butter Manufacturers,
formerly Professor of Dairying in the Iowa State College, Ames, Ia.*

AND

C. LARSEN, M.S.A.

*Professor of Dairy Husbandary, So. Dak., State College, Brookings, S. D.;
formerly Associate Professor, Iowa State College, Ames, Ia.*

THIRD EDITION, LARGELY REWRITTEN

TOTAL ISSUE, SEVENTEEN THOUSAND

NEW YORK
JOHN WILEY & SONS, INC.

LONDON: CHAPMAN & HALL, LIMITED

1922

Copyright, 1906, 1908, 1922,

BY

G. L. MCKAY AND C. LARSEN

PRESS OF
BRAUNWORTH & CO.,
BOOK MANUFACTURERS
BROOKLYN, N. Y.

PREFACE TO THIRD EDITION

THE science of dairying is constantly broadening. The methods and art of manufacturing the best quality of butter have gradually changed in conformity with the scientific principles involved, and no one should now undertake to manufacture butter until he has made a careful study of the principles governing the best methods of manufacture.

The authors admit that, in our present state of knowledge and experimental progress, it is in some instances difficult to distinguish well-established facts from those not universally confirmed; hence, it has been their object to give only information supported by the preponderance of experimental evidence.

The first and second editions of this book have been received by the dairy schools and the practical creamerymen in a manner indicating that the work has met with general approval. The third edition has been carefully revised, and additional chapters have been added. The new chapters are: first, Defects Found in Butter—Some of the Causes and their Prevention; second, Neutralization of Cream; third, Milk and its Products as Foods—High Value of Milk Fat; fourth, Cold Storage and Butter for Storage Purposes; fifth, New Tests, including Accurate Method of Determining Per Cent of Fat in Buttermilk, Skim-milk and Ice Cream. The authors' endeavor has been to bring the book strictly up to date, and to include the latest and most approved methods in dairying.

The authors believe that the subject of dairying should no longer be treated as a whole, and for this reason have treated special branches of the subject. In this volume they have endeavored to give such scientific information as relates to the manufacture of butter.

The scientific knowledge embodied in the present book has been acquired, from time to time, through work done by various investigators at different Experiment Stations and by leading scientists of the Federal Dairy Division.

It may be added that the statistics and tables given in this work have been quoted from noted, reliable authorities.

The authors are indebted to the following companies and individuals for the use of electrotypes: Cherry Brothers, Cedar Rapids, Iowa; Waterloo Cream Separator Company and Iowa Separator Company, Waterloo, Iowa; Vermont Farm Machine Company, Bellows Falls, Vermont; Burrell & Company, Little Falls, New York; Empire Cream Separator Company and Jensen Creamery Machinery Company, Bloomfield, New Jersey; Dairy Queen Mfg. Company, Flora, Indiana; Elyria Enameled Products Company, Elyria, Ohio; Rice & Adams, Buffalo, New York; Worcester Salt Company, New York City; Russell & Hastings, Madison, Wisconsin; Louis F. Nafis, Creamery Package Company, Borden & Selleck Company, De Laval Separator Company, Arnold & Company, Diamond Crystal Salt Company and Davis-Watkins Dairymen's Mfg. Company, Chicago; Kirschbraun & Sons, Omaha, Nebraska; Professor M. Mortenson, Ames, Iowa; and Strawberry Point Creamery, Strawberry Point, Iowa.

APRIL, 1922.

G. L. MCKAY.

C. LARSEN.

CONTENTS

CHAPTER I

	PAGE
HISTORY OF BUTTER-MAKING AND COMPOSITION OF MILK.....	1
1. Definition of Milk.....	3
2. Composition of Milk.....	4
3. Variation of Total Solids.....	5
4. Water.....	6
5. Fat in Milk.....	8
6. Properties of Fat.....	10
7. Glycerides of Fat.....	10
8. Conduon of Fat.....	11
9. Theories in Regard to Films Enveloping Fat Globules.....	11
10. Classes of Fats.....	13
A. Volatile.....	13
B. Non-volatile.....	14
11. Composition of Butter Fat.....	15
12. Proteids (Albuminoids).....	16
A. Casein.....	17
B. Albumen.....	18
13. Sugar.....	18
14. Ash.....	19
15. Gases of Milk.....	20
16. Coloring Matter.....	22
17. Other Constituents of Milk.....	22

CHAPTER II

MILK SECRETION.....	23
1. Mammary Gland as a Secretary Organ.....	23
2. Internal Structure of Cow's Udder.....	23
3. Theories of Milk Secretion.....	26
4. Conditions Affecting Secretion of Milk.....	28
5. External Appearance of Udder.....	30
6. Milk Fever.....	30

CHAPTER III

	PAGE
PROPERTIES OF MILK.....	32
1. Color.....	32
2. Flavor.....	32
3. Opacity of Milk.....	32
4. Chemical Reaction of Milk.....	33
5. Specific Gravity of Milk.....	33
6. Natural Separation of Milk and Cream.....	35
7. Adhesion of Milk.....	37
8. Viscosity of Milk.....	37
9. Specific Heat of Milk.....	38
10. Effect of High Heating on Properties of Milk.....	38
(1) Destroys nearly all Germs.....	39
(2) Diminishes Viscosity or Body.....	39
(3) Drives off Gases.....	40
(4) Imparts a Cooked Taste.....	40
(5) Precipitates Albuminoid and Ash Constituents.....	41
(6) Destroys Properties of Enzymes.....	41
(7) Divides the Clusters of Fat Globules.....	42
(8) Caramelizes the Sugar.....	42
General Remarks.....	42

CHAPTER IV

MILK AND ITS PRODUCTS AS FOODS—HIGH VALUE OF MILK-FAT.....	43
1. Chemical Classification of Milk and Its Products as Foods.....	44
2. Biological Classification of Foods.....	45
A. Proteins.....	46
B. Ash or Mineral Matter.....	46
C. Two Unidentified but Essential Food Substances.....	47

CHAPTER V

FERMENTS IN MILK.....	54
1. Definition.....	54
A. Classification of Enzymes.....	54
2. Size and Shape of Bacteria.....	55
3. Favorable Conditions for Bacterial Growth.....	55
A. Food.....	55
B. Temperature.....	56
C. Moisture.....	58
4. Unfavorable Conditions for Bacterial Growth.....	58
5. Kinds of Germs Found in Milk.....	60
6. Number of Bacteria in Milk.....	62
7. Sources of Bacteria in Milk.....	62
8. Effect of Thunder Storms on Souring Milk.....	64

CHAPTER VI

	PAGE
ABNORMAL MILK.....	65
1. Colostrum Milk.....	65
2. Salty Milk.....	66
3. Bloody or Red Milk.....	67
4. Blue Milk.....	68
5. Yellow Milk.....	68
6. Ropy Milk.....	68
7. Bitter Milk.....	69
8. Milk from Cows which Have Been in Milk a Long Period.....	71
9. Milk from Spayed Cows.....	72
10. Milk from Sick Cows.....	72

CHAPTER VII

VARIATION OF FAT IN MILK AND CREAM.....	74
---	----

PART I

VARIATION OF FAT IN MILK.....	74
1. Individuality of Cows.....	74
2. Breed of Cows.....	75
3. Time between Milkings.....	75
4. Manner of Milking.....	76
5. Fore and After Milk.....	77
6. Age of Cow.....	78
7. Advance in Lactation.....	78
8. Feed of Cows.....	79
9. Environment.....	80
10. Condition of Cow.....	80

PART II

VARIATION OF FAT IN CREAM.....	81
1. Cream Screw Adjustment.....	82
2. Richness of Milk.....	83
3. Rate of Inflow.....	85
4. Speed of Machine.....	87
5. Temperature of Milk.....	88
6. Amount of Water or Skim Milk Used to Flush the Bowl.....	90

CHAPTER VIII

RECEIVING, SAMPLING, GRADING AND TESTING MILK AND CREAM.....	92
1. Receiving and Grading of Milk and Cream.....	92
A. Detection of Abnormal Milk and Cream through the Senses.....	93
B. Use of Acid Tests.....	94

	PAGE
C. Use of Fermentation Tests	94
<i>a.</i> Gerber and Wisconsin Curd Tests	95
D. Grading Milk by Heating	96
E. Use of Babcock Test and Lactometer	97
<i>a.</i> Babcock Test of Milk	98
<i>b.</i> Babcock Test of Cream	99
<i>c.</i> Does the Babcock Test, as Ordinarily Applied to Cream, Give Too High a Reading?	100
<i>d.</i> Babcock Test of Buttermilk and Skim-milk—American Association Test	101
<i>e.</i> American Association Test	103
<i>f.</i> Determination of the Per Cent of Fat in Butter	107
<i>F.</i> Sediment Test	116
2. Necessity of Good Milk	117
3. Sampling of Milk	118
4. Sampling Tube	120
5. Sampling Churned Milk	122
6. Frozen Milk	123
7. Sour and Coagulated Milk	123
8. Apportioning Skim-milk	124
9. Washing Cans	125

CHAPTER IX

COMPOSITE SAMPLES	127
1. Definition	127
2. When to Sample	127
3. Kind of Preservatives to Add	127
4. Arrangement of Composite Samples	128
5. Care of Composite Samples	129
6. Average Sample	130
7. Composite Sampling without the Use of Preservatives	130

CHAPTER X

CREAMERY CALCULATION	131
1. Find Average Per cent of Fat	131
2. Calculation of Overrun	133
(1) Thoroughness of Skimming	133
(2) Completeness of Churning	133
(3) General Losses in Creamery	133
(4) Composition of Butter Manufactured	133
3. Calculation of Churn Yield	135
4. What Should the Overrun in a Creamery Be?	135
5. Calculation of Dividends	137
6. Cream Raising Coefficient	140
7. Statement to Patrons	140
8. Paying for Fat in Cream as Compared with Paying for Fat in Milk	143

CHAPTER XI

	PAGE
HEATING MILK PREVIOUS TO SKIMMING.....	145
1. Reasons for Heating.....	145
2. Advantages of Warming Milk to High Temperature Previous to Skimming.....	146
3. How Heated.....	147

CHAPTER XII

SEPARATION OF CREAM.....	149
1. Gravity Creaming.....	149
A. Shallow-pan System.....	149
B. Deep-setting System.....	150
a. Probable Explanation.....	152
C. Water-dilution Cream (Hydraulic).....	153
2. Centrifugal Creaming.....	154
A. Advantages.....	155
B. History of Centrifugal Separators.....	155
C. Modern Separators.....	157
D. Classification of Separators.....	158
E. Process of Separation.....	158
F. Conditions Affecting Efficiency of Separators.....	161
a. Manner of Heating Milk.....	161
b. Condition of the Milk.....	163
c. Overfeeding the Separator.....	163
d. Speed.....	164
e. Steadiness in Running.....	165
f. Thickness of Cream.....	165
g. Slush in Bowl.....	165
h. General Remarks.....	166

CHAPTER XIII

FARM SEPARATORS.....	168
1. Introduction of Farm Separators.....	168
2. Reasons for Introducing Farm Separators.....	168
3. Objections to Farm Separators.....	171
4. Thickness of Cream.....	172
5. Power for Farm Separators.....	174
6. Care of Cream on the Farm.....	176
7. Disposition of Cream.....	179
A. Shipping of Cream.....	180
B. Making Butter on the Farm.....	180

CHAPTER XIV

	PAGE
NEUTRALIZATION—THE “NEUTRALIZATION” OF CREAM.....	183
1. Neutralization, Principle of.....	183
2. Neutralization of Cream for Butter-making.....	184
3. The Preparation and Use of Lime as a Neutralizer.....	192
4. Pints of Lime Mixture Required to Reduce Acidity to .25 Per Cent (Table).....	106
5. Other Neutralizers.....	199

CHAPTER XV

PASTEURIZATION.....	201
1. Definition.....	201
2. Storch Test for Pasteurization.....	201
3. Pasteurization Temperatures.....	202
4. Good Milk and Cream Important.....	204
5. Sanitation Must Accompany Pasteurization.....	206
6. Methods of Pasteurization.....	208
A. Flash or Instantaneous Method.....	208
B. Vat or Holding Method.....	208
C. Combined Flash and Holding Method.....	208
7. Efficiency of Pasteurizers.....	210
8. Cost of Pasteurization.....	212
9. Disadvantages of Pasteurization.....	214
10. Advantages of Pasteurization.....	214

CHAPTER XVI

CREAM RIPENING AND STARTERS.....	215
Cream Ripening:	
1. Definition.....	215
2. Objects of Ripening.....	215
3. Ripening Temperature of Cream.....	220
4. Amount of Starter to Add to Cream.....	221
5. Mixing the Starter with the Cream.....	221
6. Tests for Acidity.....	221
A. Mann’s Test.....	222
B. Farrington Test.....	223
7. Degree of Acidity that Cream Should be Ripened to.....	224
STARTERS:	
8. Definition.....	225
9. History.....	226
10. Classification of Starters.....	226
11. Preparation of Natural Starters.....	226

	PAGE
12. Commercial Starters or Cultures	227
13. Preparation of Commercial Starters	230
14. Inoculation	232
15. Milk Powder for Starters	235
16. Length of Time a Starter Can be Carried	236
17. Poor Starters	236
18. Under-ripening and Over-ripening of Starters	237
19. Amount of Starter to Use	237
20. Use of Starter-cans	238

CHAPTER XVII

CHURNING AND WASHING BUTTER	239
1. Definition	239
2. Conditions Affecting the Churnability of Cream	240
<i>A.</i> Temperature	240
<i>B.</i> Influence of Length of Time Held at Churning Temperature	245
<i>C.</i> Richness of Cream	245
<i>D.</i> Amount of Cream in Churn	247
<i>E.</i> Degree of Ripeness	248
<i>F.</i> Nature of Agitation	249
<i>G.</i> Size of Fat Globules	252
3. Straining of Cream	253
4. Color	253
5. When to Stop the Churning	255
6. Churning Mixed Sweet and Sour Cream	258
7. Difficult Churning	258
8. Keeping Churn in Sweet Condition	260
9. To Prevent Butter from "Sticking" to Churn	262
10. Washing of Butter	263
<i>A.</i> Purpose of Washing	263
<i>B.</i> Temperature of Wash Water	263
<i>C.</i> Kind of Wash Water to Use	265
11. Methods of Purifying Wash Water	266
<i>A.</i> Filtration	266
<i>a.</i> Continuous	269
<i>b.</i> Intermittent	270
<i>B.</i> Pasteurization	266
12. Advantages of Purification of Wash Water	271

CHAPTER XVIII

SALTING AND WORKING OF BUTTER	272
1. Objects of Salting	272
2. Amount of Salt to Use to Produce Proper Flavor	272
3. Effects of Salt upon Keeping Properties	272, 273

	PAGE
4. Salt Facilitates the Removal of Buttermilk.....	275
5. Salt in Relation to Water in Butter.....	275
6. Kind and Condition of Salt.....	277
7. Gritty Butter.....	278
8. Mottled Butter.....	279
9. Prevention of Mottles in Butter.....	284
10. Curdy Specks in Butter.....	285
11. Brine Salting.....	287
12. Salt Test.....	288
<i>A.</i> Principles of the Test.....	288
<i>B.</i> Chemical Changes that Take Place.....	288
<i>C.</i> Features of Practical Salt Tests.....	289
<i>D.</i> To Make a Salt Test.....	290
13. Working of Butter, Objects of.....	291
14. Moisture Tests of Butter.....	293

CHAPTER XIX

PREPARING BUTTER FOR MARKET AND PREVENTION OF MOLD.....	294
1. Styles of Package and Kinds of Wood Used.....	294
2. Storing Butter in Creameries.....	296
3. Cost of Manufacturing Butter.....	297
4. Treatment of Tubs and Boxes.....	300
5. Paraffining of Tubs.....	302
6. Paraffining Tubs Reduces Loss from Shrinkage.....	303
7. Treatment of Parchment Paper.....	304
8. Yeasts and Molds in Butter.....	304
9. Mold on Butter.....	306
<i>A.</i> Conditions Favorable to Growth of Molds.....	307
<i>B.</i> Discolorations.....	307
<i>C.</i> Propagation of Molds.....	307
<i>D.</i> Sources of Mold on Butter.....	307

CHAPTER XX

THE COMPOSITION OF BUTTER AND FACTORS THAT INFLUENCE ITS CONTROL....	309
1. Acts and Rulings as to Composition of Butter.....	309
2. Compounds for Increasing Yield of Butter.....	310
3. Need for Regulations.....	311
4. Control of Moisture in Butter.....	312
5. Analyses of Commercial Butter between Thirty and Forty Years Ago.....	315
6. Standards in Different Countries.....	317
7. Factors that Aid in Moisture Control.....	318

CHAPTER XXI

	PAGE
DEFECTS FOUND IN BUTTER—SOME OF THE CAUSES AND THEIR PREVENTION	323
1. Flat or Insipid Flavor.....	323
2. Stable Flavors.....	324
3. Flavors Acquired by Absorption.....	324
4. Cheesy Flavor.....	324
5. Sour Flavor.....	325
6. Faulty Factory Conditions.....	325
7. Feed Flavors.....	327
8. Removal of Garlic or Onion Flavors.....	327
A. To Eradicate Wild Garlic.....	328
9. Advance in Lactation, Winter Feeds and Stable Conditions.....	320
10. Tallowy Flavor.....	332
11. Metallic Flavors.....	335
12. Fishy Flavor.....	336

CHAPTER XXII

JUDGING AND GRADING BUTTER.....	340
1. Standard for Judging.....	340
2. Manner of Judging.....	341
A. Body.....	341
B. Flavor.....	341
C. Color.....	341
D. Salt.....	342
E. Style.....	342
3. Classification—Grades and Scores.....	342
A. New York Classification.....	342
B. Chicago Classification.....	347
4. Export Butter.....	350

CHAPTER XXIII

COLD STORAGE AND BUTTER FOR STORAGE PURPOSES.....	352
1. History of Cold Storage.....	352
2. Mechanical Refrigeration.....	353, 363, 375
3. Benefits of Cold Storage.....	353
4. Cost of Storage.....	355
5. Should Cold Storage Butter be Branded?.....	356
6. Butter for Storage.....	357
7. Working and Packing Butter for Storage Purposes.....	360

CHAPTER XXIV

	PAGE
COOLING FACILITIES FOR CREAMERIES.....	362
1. Cooling Systems—Natural Ice, Mechanical Refrigeration and Cold	
Water.....	362
A. Natural Ice System.....	365
<i>a.</i> Kind of Ice House.....	365
<i>b.</i> Size and Shape of Ice House.....	368
<i>c.</i> Filling the Ice House.....	372
<i>d.</i> Source of Ice.....	373
B. Use of Ice in Cooling Cream.....	374
<i>a.</i> Directly.....	374
<i>b.</i> Indirectly.....	374
C. Mechanical Refrigeration.....	375
<i>a.</i> Application in Creameries.....	375
<i>b.</i> Chemicals Used for Mechanical Refrigeration.....	376
<i>c.</i> Principles of Producing Cold Artificially.....	376
(1) Compression.....	377
(2) Condensation.....	377
(3) Expansion.....	378
<i>d.</i> Transferring the Cold.....	378

CHAPTER XXV

ECONOMIC OPERATION OF CREAMERY.....	381
1. Firing the Boiler.....	381
2. Burning Wood or Coal.....	382
3. Daily Weighing of Coal Used.....	383
4. Cleaning the Boiler.....	384
5. Priming of Boilers.....	384
6. The Injector.....	385
7. Oil Separators.....	385
8. Belt, Pulley and Speed Calculation.....	385

APPENDIX

I. Legal Standards for Dairy Products.....	387
II. Metric System of Weights and Measures.....	388

BUTTER-MAKING

CHAPTER I

HISTORY OF BUTTER-MAKING AND COMPOSITION OF MILK

THE art of butter-making in some form dates back to time immemorial. History tells us that butter is one of the oldest, as well as one of the most universal, articles of diet. We are told it was used in some form two thousand years before the birth of Christ. References are made to it in early Biblical and other ancient history. We read, in Genesis, that when Abraham was visited by Angels, who appeared in the form of men, "he took butter and milk and the calf which he had dressed and set it before them." The word "butter" is mentioned in the Bible seven times. It is known that the Scythians and Greeks used butter in 450 B.C. A little later there is a record of the Persians making and using it. In the early centuries butter was employed in many ways. The Hindoos offered it as a sacrifice in their worship. The Greeks and Romans did not eat it, but used it as a remedy for injuries to the skin. It was considered by them that the soot of burned butter was good for sore eyes. The Romans also used it as an ointment for the skin and the hair. This practice was common in Macedonia, and it is reported that in many cold regions persons use butter as a bath. In Spain, as late as the seventeenth century, it was found in medicine shops for external application only. In the rural districts in Germany, fresh unsalted butter has been employed as a cooling salve for burns, and has been used to some extent in this country.

In early times, butter was not generally used as a food, but

when it was this was for the purpose of enriching other foods in cooking. We are told it was stored in a melted condition, and was never eaten when fresh.

In the early methods of making butter, churning was brought about by agitation of whole milk. In our own country at the present time, in some of the Southern States, the method of churning whole milk rather than cream is still followed by farmers' wives. Some difference of opinion exists as to the early methods used for creating agitation sufficiently to gather butter from the milk. Such methods were used as placing the milk in earthen vessels and beating it with the hands until butter formed. Later, wooden stirring sticks were used for the purpose of creating agitation. The Arabs churned their milk by placing it in leather bags and dragging them over the ground by means of a rope attached to a horse's saddle. Another method used was that of placing the milk in skin bags, fastening them to a tree and swinging them back and forth to bring about agitation. (See cut, Chapter XVII.) As time passed, more complete devices or methods were adopted for churning, such as the dash churn. Following the dash churn came the square box churn—which was used extensively in creameries about twenty years ago—and the table butter worker. Now we have the modern up-to-date combined churn. Setting milk in cold water and permitting the cream to rise lessened the time of churning and brought the manufacture of butter down to a science.

The adoption of the centrifugal machine for separating the fat from the milk was one of the greatest advancements in butter-making. (See cut of first centrifugal machine in Chapter XII.) The first centrifugal cream separator used in Iowa—possibly the first used in America—was a power separator which Jeppe Slipsgaard brought with him from Denmark in 1882, and which was used in a Danish community near Cedar Falls, in Black Hawk County. It is worthy of note that this machine was so novel to the customs officers in New York that they held it for two months before they could decide as to whether it was constructed of iron or steel. They finally decided that it was of steel construction and fixed the duty at \$93.

Marked improvements have been made in the manufacture of butter by the adoption of scientific methods and the use of modern equipments. Changes have been made in the period of lactation. Formerly the cow furnished milk only for her young. Through the efforts of man, by breeding and selecting, the period of lactation has been lengthened until at the present time it extends over a period of ten months. The cow at the present time is recognized as one of the most economical producers of human food, hence, dairying has advanced rapidly in all countries that are adapted for the production of forage plants that are suitable for feeding the cow.

The United States at the present time produces five times as much butter as any other country. The late census estimates 863,577,000 pounds of factory butter manufactured in 1920 and 675,000,000 pounds of farm butter.

Notwithstanding the number of years that butter, milk and other dairy products have been used for food, it is less than ten years since the physiologists discovered that butter and milk contained certain food elements that are essential for the growth of the young that had escaped investigations made by eminent chemists. This discovery was brought about by feeding experiments by such noted physiologists as Dr. F. G. Hopkins of Cambridge University, England, and Dr. E. V. McCollum of Johns Hopkins University in this country. The discoveries made by these eminent authorities will no doubt be the means of creating a greater demand for dairy products of all kinds.

Definition.—Normal milk is a liquid secreted in special glands of all females belonging to the mammalian group. It is composed chiefly of water, proteids, fats, sugar, and minerals. Coloring-matters and gases and some organic acids are found in small quantities.

All normal milk from the different classes of animals, such as mare, buffalo, goat, ewe, ass, and cow, has a general resemblance in that it all contains water, fat, proteids, sugar, and ash. But milk from different animals varies in the relative proportions of its constituents. The chemical and physical properties are not alike. When human milk is treated with half its volume of

ammonium hydrate and kept at a temperature of 60° C. for about twenty minutes, it assumes an intense red color. Cow's milk turns faintly yellow if treated in the same way. This test was reported by Unikoff, of St. Petersburg (now Petrograd), at the meeting of the Medical Section, Royal Academy of Medicine, in Ireland. The various kinds of milk also differ from each other in their behavior towards rennet. Richmond has divided milk into two classes: Class I includes milk from the ewe, buffalo, goat, and cow. When rennet is added to the milk from these animals, the casein coagulates into a firm curd. Class II includes human milk, milk of the ass, and mare. When rennet is added to the milk of these animals, a soft curd or none at all is formed. The latter class seems to include the animals without horns, while the first includes those with horns.

As the cow's milk is used as a food to a greater extent than that of any other animal, it has been subjected to more extended and more careful investigation, and, as a consequence, more definite knowledge has been obtained concerning its composition, properties, and uses. The succeeding discussions have reference to cow's milk, if not otherwise stated.

Composition of Milk.—It is impossible to get accurate figures on the composition of milk, as each of the milk constituents is subject to fluctuation from various conditions, such as individuality of cow, breed, season of the year, stage of lactation, milking and environment.

The average composition, as determined by 280,000 analyses reported by Richmond is as follows:

Water.....	87.35
Fat.....	3.75
Milk-sugar.....	4.70
Proteids {	
Casein.....	3.00
Albumen, etc.45
Ash.....	.75

The composition of various kinds of milk is given by König as follows:

	No. of Analy- ses	Water	Fat	Casein and Al- bumen	Milk- sugar	Ash	Specific Gravity
Human.....	107	87.41	3.78	2.29	6.21	.31	1.0270
Mare.....	50	90.78	1.21	1.99	5.67	.35	1.0347
Buffalo.....	8	82.25	7.51	5.05	4.44	.75	1.0350
Ass.....	7	89.64	1.64	2.22	5.99	.51	1.0345
Cow.....	793	87.17	3.69	3.55	4.88	.71	1.0316
Ewe.....	32	80.82	6.86	6.52	4.91	.89	1.0341
Goat.....	38	85.71	4.78	4.29	4.46	.76	1.0328
Sow.....	8	84.04	4.55	7.23	3.23	1.05	1.038
Bitch.....	28	75.44	9.57	11.17	3.09	.73	1.035
Elephant.....	3	79.30	9.10	2.51	8.59	.50	1.0313
Hippopotamus.....	1	90.43	4.51	4.40	.11
Camel.....	3	86.57	3.07	4	5.59	.77	1.042
Llama.....	3	86.55	3.15	3.90	5.60	.80	1.034

Variation of Total Solids.—As applied to milk, “Total Solids,” is a term that includes fat, casein, albumen, sugar, and ash; in other words, all the milk constituents except the water. “Solids Not Fat” is a term often used, and includes the casein, albumen, sugar, and ash, or all the milk constituents except water and fat. “Serum” is a term used to designate all the milk constituents except the fat. The fat is the most valuable constituent of the total solids. The variation in the total solids of milk during the summer months is shown in the table quoted below from Dr. Van Slyke of Geneva, New York:

Month	Per Cent of Water	Per Cent of Total Solids
May.....	87.44	12.56
June.....	87.31	12.69
July.....	87.52	12.48
August.....	87.37	12.63
September.....	87	13
October.....	86.55	13.45

Dr. Van Slyke also studied the effect of the lactation period upon the total solids in milk. A herd of fifty cows, calving in

different months of the year, was used in the experiment. The per cent of total solids of this herd seems to average a little high all through the ten months. The total solids were found to be 14 per cent during the first month, decreasing to 13.47 per cent during the next two months, then gradually increasing with the advance of the lactation period. In the tenth month the average total solids was 14.83 per cent. Pingree, of Pennsylvania, reports having found normal milk from a cow which contained 17.01 per cent total solids. Sherman¹ reports a very high average total of the milk solids. He treated the milk from thirteen cows, and found it to contain on an average 18.03 per cent of total solids. König reports a minimum of total solids of 9.31 per cent, a maximum of 19.68 per cent, and an average of 12.83 per cent. The average total solids quoted above from Richmond is 12.65 per cent, which agrees closely with König's results.

The difference in total solids of milk from some of the leading breeds has also been studied by Dr. Van Slyke, and the results are as follows:

Breed	Per Cent of Water	Per Cent of Total Solids
Holstein.....	88.20	11.80
Ayrshire.....	87.25	12.75
Shorthorn.....	85.70	14.30
Devon.....	85.50	14.50
Guernsey.....	85.10	14.90
Jersey.....	84.60	15.40

The maximum and minimum amounts of total solids mentioned above are abnormal cases. The normal variations of the solids in milk are within comparatively narrow limits. For this reason the minimum standard for total milk solids, in States where dairy laws are in force, is fixed by law. Usually 12 per cent is the minimum.

Water.—From what has been said above concerning the total milk solids, it will be seen that water constitutes by far the largest

¹ Jour. Am. Chem. Soc.

portion of milk. It is quite uniform, and in milk from a mixed herd the water seldom falls below 86 per cent and seldom exceeds 88 per cent. Variations ranging from a little less than 80 per cent to a trifle over 90 per cent are on record. But such variations must be looked upon as occurring in only a *very* few special cases.

It has often been asserted that cows in the spring of the year, when they are pasturing on new grass, or feeding on other succulent foods, yield milk which contains an excess of water. Under such conditions there is a tendency for cows to produce milk with a water content a trifle higher, as has already been shown by the figures quoted from Dr. Van Slyke. As a rule this is much over-estimated. It is even a common occurrence to hear creamery operators say that their "soft" or "slushy" butter, in the early spring, is due to the excess of water present in the milk. This particular phase will be discussed further under the heading of "Fat in Milk."

The following question has often been raised: Is the water in milk the same, or any more valuable than water obtained from other natural sources? The water in milk, so far as known, is transuded from the blood-vessels in the udder into the milk glands. It is so perfectly mixed with the other milk constituents, and holds the milk solids in such perfect emulsion and solution that it would seemingly be impossible to prepare milk so perfectly by artificial means. However, a substance is prepared by Jacob C. Van Marken, Neuweid, Germany, which, when added to water, produces a substance similar in appearance to watered skimmed milk. The preparation is named "Kalberrahm Vita." The first name literally means calf-cream. It has a syrupy consistency, and in appearance resembles light-brownish molasses. It is sold in tin cans, and recommended highly for calf feeding when mixed with skimmed milk. When mixed with water, it is recommended highly for hog-feeding.

Water distilled from milk has the same appearance as ordinary distilled water. It is clear and colorless. The chemical reaction when phenolphthalein is used as an indicator is neutral, as is that of ordinary distilled water, even when distilled from milk in which acid has developed. But there is a considerable

difference in the taste and smell. This indicates that some of the volatile substances are distilled over with the water. The probability is that these flavoring substances are so closely associated with water in milk that they are inseparable, and that the only place where this water can be prepared so as to assume these qualities is in the cow's udder. The conclusion would then be that the water in normal cow's milk cannot be distilled and replaced by natural water without the loss of the normal good flavor of the product.

FAT IN MILK

This is by far the most important constituent of milk, especially to creamery operators. It exists in the milk in suspension, in the form of globules so small as to be invisible to the naked eye. Fat globules, at ordinary living-room temperature, are present in milk in a liquid form. Cooling the milk to a very low temperature (about 50° F.) hardens them. When the globules are caused to unite, as in churning, they also solidify.

The size of the fat-globules is very minute, and varies considerably, according to breeds, individual cows, and the stage in the lactation period. The globules in the milk from the same cow also vary a great deal. Lloyd found fat-globules in Jersey milk to be from 8 to 12 micro-millimeters in diameter. Very few were less than 4 micro-millimeters (a micro-millimeter is $\frac{1}{1000}$ millimeter, or $\frac{1}{25000}$ of an inch). The majority of the fat-globules in milk from Shorthorn cows measured from 6 to 8 micro-millimeters in diameter. According to Fleischmann, the size of fat-globules varies between 1.6 micro-millimeters and 10 micro-millimeters in diameter. A Danish investigator maintains that the diameter of fat-globules is between .0063 and .00014 millimeter, and that 1 cubic centimeter of milk contains from 2.6 to 11.7 million globules. He also asserts that a reflection of the light renders it very difficult to get the proper size of the fat-globules, as the light tends to make the globules appear larger than they are in reality.

It has been maintained by some that the larger fat-globules contain fats which are different from those contained in the

smaller globules. But this is by some investigators considered to be a matter of conjecture. Most authorities now believe

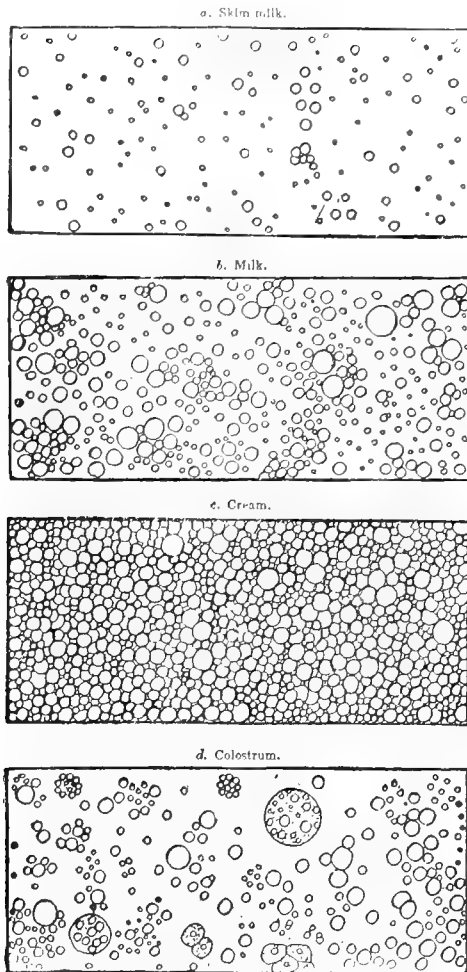

FIG. 1.—Microscopic appearance of different kinds of milk. Magnified 300 times. (U. S. Farmers' Bul. No. 42.)

that there is no difference in the kinds of fat of the different-sized globules, even though some experiments ¹ show that fat composed

¹ Gembloux, Belgium, Creamery Jour., London, No. 8, Vol. I.

of larger globules has a finer flavor, and a little more oily appearance.

From what has been said, it will be seen that the minuteness of the fat-globules is almost inconceivable. They were first discovered in 1697 by A. von Leeuwenhoek. The minute state of division, or the form of emulsion in which they exist in milk, renders it easy to digest when consumed as a food.

Properties of Fat.—The specific gravity of pure butter-fat at 15° C. is .93002. The refractive index of butter-fat at 22° C. is on an average 1.459. The melting-point of pure butter-fat, as now determined, varies between 32° and 37° C. (90° F. and 99° F.)

When pure butter-fat is rapidly cooled, it solidifies into one solid mass; but if allowed to cool gradually, part of it solidifies, and part of it remains a liquid longer than other parts. This seems to indicate that some fats with a high melting-point separate out from the fats with a low melting-point. This behavior of pure butter-fat is not well understood, as it contradicts the now accepted theory that the different fats are in chemical combination with each other, rather than a mechanical mixture of different glycerides of fat.

Glycerides of Fat.—By this term we understand that the fatty acid radicals are in chemical combination with the glycerol (glycerine) radical, thus:

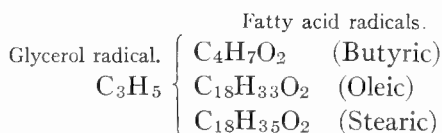

The chemical formula for glycerine is:

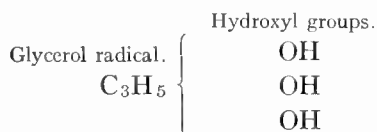

The difference and similarity of these two formulas are easily observed, and the reason why the term "Glyceride of Fat" has been applied to such a compound is evident.

Condition of Fat.—Whether the fats in milk exist in chemical combination, or whether they exist as glyceride of butyrin, stearin, olein, etc., in the form of a mechanical mixture, is a question in dispute. If they exist in the latter form, the composition of the different fats must be as follows:

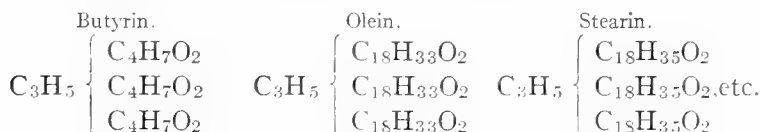

and the total fat made up of a mechanical mixture of these and the remainder of the fats in butter-fat.

Richmond and other authors believe that fat probably exists in milk chemically, as first mentioned and illustrated; because, if the fat were a mixture of glycerine tributyrate with other glycerides of fat, butyrin or glycerol tributyrate could be dissolved out by the use of alcohol. But this is not the case. Moreover, if butyrin existed separately in milk, it would be possible to distill it off under reduced pressure. This cannot be done.

Theory in Regard to Films Enveloping Fat-globules. The extreme minuteness of the fat-globules in milk renders it almost impossible to determine by direct microscopical observation whether there is a membrane around each globule or not. Fleischmann and Lloyd assert that, so far as they were able to detect, there is no real membrane surrounding each globule.

The theory generally accepted in the past was that the film surrounding the fat-globules was simply due to surface tension, or to the fact that the molecules of the fat have a greater attraction for themselves than they have for the molecules of the serum in which they are held in suspension. In support of this two arguments are advanced.

(1) The natural milk-fat may be removed from milk and artificial fat substituted in its place. The resultant milk has characteristics similar to milk containing normal fat, that is, the emulsion which milk forms with the artificial fat is apparently like that formed with the natural fat.

(2) If there were a special albuminous membrane around

each fat-globule, cream should contain a higher percentage of albuminoids than milk. This, Richmond maintains, is not so.

Dr. Storch concludes from extensive researches that there is a gelatinous membrane enveloping the fat-globules. His conclusions are based mainly upon the first three reasons given below. The other facts mentioned also support his conclusions:

(1) When milk has been stained with ammoniacal picrocarmine, and the cream washed with water until it is free from milk-sugar, a stained layer is present around each globule.

(2) He has succeeded in isolating this gelatinous substance from cream and butter. Owing to its existence in these two substances, he assumes that it is also present in milk.

(3) When ether is added to milk, the fat-globules dissolve with difficulty, unless some alkali is added to the milk first.

(4) Bichamp maintains that when ether is added to milk the fat-globules are enlarged due to the ether passing through the supposed membrane by the process of osmosis. He considers this fact sufficient to prove that there is a membrane encircling each globule.

(5) Butter containing 85 to 86 per cent fat is asserted by Richmond to have the same consistency as cream containing about 72 per cent fat at the same temperature. The solidity of butter is due to the close proximity of the fat-globules. Now, if cream with less fat has the same consistency as butter, the proximity of the fat-globules must be equal to that of the butter; this would indicate that there is a membrane and that this membrane increases the size of the fat-globules.

(6) The fact that cream separated by centrifugal force is more easily churned than cream of the same richness separated by gravity methods, would also be explained if the fat-globules in milk had such a membrane surrounding them.

This membrane, or what is believed to be a membrane, Storch has isolated and analyzed. He finds it to consist of 94 per cent of water and 6 per cent of proteid.

The reasons deduced by Storch are strong; and the behavior of cream and butter renders it probable that there is such a membrane enveloping each globule of fat.

CLASSES OF FATS

There are two great classes or groups of fats present in the butter, namely:

- (1) Volatile and Soluble,
- (2) Non-volatile and Insoluble.

It was previously stated that little is known concerning the way in which the fatty acids are combined with glycerine in the milk; but, for the sake of convenience, the fats will be referred to as if they existed as separate glycerides of fat.

The terms "Volatile" and "Non-volatile" are applied to the glycerides of fat, or to the fats as they exist in butter. Strictly speaking, this is not proper, as they do not assume the volatile characteristics until the glycerine separates from the fatty acids; it is only then that the latter become volatile.

Volatile Fats.—The first group, or the volatile fats, include butyrim, caproin, caprylin, caprim, and laurin. Butyrim is the one present in the largest proportion. Laurin and caprim are partially non-volatile. Butyrim is the most important fat belonging to the volatile group. It is the most important quantitatively and also qualitatively. So far as is known, butyrim is the least stable of any of the butter-fats. Under normal conditions, so long as the fatty acid remains in combination with the glycerol, it is neither volatile nor soluble in water; but as soon as separation takes place, due to the action of micro-organisms, or to the effect of light and air, it becomes volatile, and escapes in the form of gas.

It is also claimed that these volatile fats have the special properties of absorbing odors and gases to a greater extent than any of the other fats. This absorption takes place when fat comes into contact with the undesirable taints. For this reason it is essential that milk, cream or butter be kept away from any foreign, undesirable odors. These taints may also be imparted to the fat before the milk is drawn. If the cow is fed on undesirable food, such as turnips, onions, garlic, etc., the milk from the cow assumes undesirable characteristic flavors which can easily be recognized in the finished product. On the other hand, such

foods as well-cured clover hay and bran seem to impart desirable flavors to milk and butter.

The presence of these volatile fats in butter is quite uniform, and is a distinguishing feature of pure butter-fat. The detection of adulteration of butter with foreign fats is based chiefly upon the presence of these volatile fats. The characteristic desirable flavor of butter is also believed to be due to the presence of the volatile fats. The volatile fats vary but slightly during the different seasons of the year. They are present in the greatest proportion during the spring and early summer months, when cows are fed on grass, and also during the early stage of the period of lactation. They decrease gradually as the lactation period advances.

Volatile fats comprise about 8 per cent of the total fats in milk.

Non-volatile Fats.—This group constitutes about 92 per cent of the total fats in butter. Chemists now agree that palmitin, stearin, olein, and myristin are the most important ones to be considered, as will be seen from the table quoted from Richmond.

These non-volatile fats are of special importance, as the relative amount of each of these fats largely causes the variation in the hardness and softness of the butter and butter-fat. The melting-point of these different fats varies according to the different investigators: olein is a liquid at ordinary temperatures and melts at about 41° F.; stearin, on the other hand, has a melting-point of about 150° F.; palmitin also has a high melting-point, namely, about 142° F.; myristin melts at about 129° F.

Olein has been found to be present in the greatest proportion during the spring, when cows are fed on grass. When cows are fed on normal dry food, as in the winter time, it is present in a much less degree. This, together with the small increase of volatile fats, is the cause of the softer butter so frequent in the spring. The hardness of the butter in the fall or winter is due chiefly to the presence of a slightly increased amount of the fats, with a high melting-point, as mentioned above.

From what has been said above, one is led to believe that, by melting a sample of butter which contains these different

fats, the fats with a low melting-point would melt first, and leave the remainder in an unmelted condition. Such is not the case. Butter-fat in this respect behaves a good deal like different metals with different fusing-points. When they are melted and mixed together, cooled and then remelted they assume a common melting-point. Butter-fat behaves in the same way. It melts at a temperature of 91° to 96° F.

As the body temperature of cows (about 101° F.) is above this temperature, the fat globules are present in the milk in liquid form when it is first drawn. A peculiarity about these fat-globules in milk is that the milk and fat may be cooled below the melting-point of the fat of butter without the fat-globules in milk being solidified. It requires a temperature of between 60° and 78° F. before the fat-globules in milk begin to solidify. When these small fat-globules are caused to unite, as during the churning process, they solidify at a higher temperature. This behavior of the fat in milk evidently must be due to a relative change in the position of the molecules of fat during the process of cooling and warming. No definite explanations, so far as is known, have been given for this condition of the fat.

The non-volatile fats found in butter-fat are practically the same as those found in other animal fats.

Composition of Butter-fat.—In his "Dairy Chemistry," Richmond gives the following composition of butter-fat, representing the mean results obtained by different observers:

		Per Cent
Fat.....	8 per cent volatile.....	{ Butyrin..... 3.85
		{ Caproin..... 3.60
		{ Caprylin..... .55
	92 per cent non-volatile.....	{ Caprin..... 1.9
		{ Laurin..... 7.4
		{ Myristin..... 20.2
		{ Palmitin..... 25.7
		{ Stearin..... 1.8
		{ Olein..... 35
		{

Richmond also gives the percentage of glycerine and fatty acids in each of the different fats, as follows:

Butyrin.....	3.85%	yielding	3.43%	fatty acids and	1.17%	glycerine
Caproin.....	3.60	yielding	3.25	fatty acids and	.86	glycerine
Caprylin.....	.55	yielding	.51	fatty acids and	.10	glycerine
Caprin.....	1.0	yielding	1.77	fatty acids and	.31	glycerine
Laurin.....	7.4	yielding	6.94	fatty acids and	1.07	glycerine
Myristin.....	20.2	yielding	10.14	fatty acids and	2.53	glycerine
Palmitin.....	25.7	yielding	24.48	fatty acids and	2.91	glycerine
Stearin.....	1.8	yielding	1.72	fatty acids and	.19	glycerine
Olein.....	.35	yielding	33.60	fatty acids and	3.39	glycerine
	100		94.84		12.53	

PROTEIDS (ALBUMINOIDS)

The proteids of milk are present partly in solution and partly in suspension. They are present in a very complex chemical form. Some of the chemists reckon as many as eight different albuminoids or proteids in milk. Duclaux claims that there are only two kinds of albuminoids, the *coagulable* and *non-coagulable casein*. He has, by the use of a fine filter, been able to separate the fat and the coagulable from the rest of the serum. The amount of coagulable casein is claimed to vary considerably, and seems to depend upon the amount of lime phosphate present. The filtrate which Duclaux obtained from filtering the milk was clear and colorless, which proves that the removal of the casein was quite complete. In order to remove casein from milk, a special filter (Chamberland) is employed. Owing to this fact, we may consider the casein to be present in suspension or semi-solution. Noted chemists, such as Babcock, Van Slyke, Duclaux, Storch, Hammarsten, Ritthausen, and Richmond, disagree upon the number of albuminoid substances found in milk, and upon the chemical behavior of each.

For all practical purposes it is safe to mention two, namely, (1) casein, and (2) albumen. Those two substances, as all agree, are present in milk, and constitute practically all the albuminoids in milk. But after these two have been separated from milk a slight precipitation can be obtained by treating the filtrate with alcohol. This has been called albumose and also lactoglobulin. From this resultant filtrate a very small amount of material containing nitrogen can again be separated. Dr. Babcock

has obtained a substance from milk called fibrin. These latter substances, however, are present in minute portions, and are believed by some of the best scientists to be the same as the albumen. Their presence in the filtrate is due to incomplete precipitation of the albumen in the first place.

Casein.—Casein is by far the most important of all of the albuminoids. It is the substance which forms the curd in cheese-making. In fresh milk, as is now understood, it is in chemical combination with lime salts. It is on this account that fresh milk shows the amphoteric reaction, which will be explained under the "Properties of Milk." The coagulation of casein by the addition of rennet or dilute acids is thought to be due to this union between the casein and lime. Fleischmann refers to this as the "*caseous matter*" of milk. The viscosity of normal milk is believed to be due in a large measure to this condition of casein in milk. It causes the casein to be present in a colloidal condition. When milk coagulates by natural or by artificial means, the union between the casein and lime phosphate is largely broken.

Casein and albumen differ in composition, in that the casein contains phosphorus and less sulphur than does albumen. Fleischmann maintains that a substance called nuclein is associated with casein, and is not found in albumen.

Casein is precipitated by the use of rennet and dilute acids, and coagulates spontaneously, due to the acid formed in the milk. The precipitates formed by the use of different precipitating agents are not alike. The curd coagulated by rennet contains more fat and calcium phosphate than the curd which is precipitated by dilute acid or by the spontaneous souring of the milk. If milk stands at air temperature for any length of time after milking, the caseous matter (or the nitrogenous matter combined with lime) tends to separate. The caseous matter of milk is not completely precipitated by heat, although heat partially destroys the union between the casein and lime. This largely destroys the action of rennet. Instead of getting a smooth solid coagulum, a more flaky precipitate is obtained. For this reason milk for cheese-making should not be heated to a high temperature. By

heating milk in a glass flask to a high temperature, and letting it stand for a time, it will be found that a mineral precipitate has settled to the bottom. This precipitate is believed to be a lime phosphate, which, previous to heating, was combined with the casein of the milk. By adding calcium chloride (CaCl_2) to milk which has been heated, its normal condition towards the action of rennet is again restored.

Albumen.—If the casein is removed from the milk by precipitation, and then filtered off, the filtrate will contain a substance which will precipitate when boiled. This is albumen, and is similar in character to albumen from the white of an egg. It differs from casein in that it is not precipitated by rennet or acids, but precipitates on heating. It does not contain any phosphates, but contains a comparatively large amount of sulphur.

As the albumen is soluble in rennet and dilute acids, it can readily be seen that it is retained in the whey obtained in cheese-making. When albumen is present in small quantities, as it is in normal milk, heating does not completely precipitate it, unless the casein or curd is first removed. If, on the other hand, albumen is present in excess, as is the case in colostrum, the major portion of the albumen is precipitated when heat is applied without first removing the casein.

Sugar.—Milk-sugar occurs in milk to the extent of about 5 per cent. It varies very little in quantity, seldom falling below $3\frac{1}{2}$ per cent and seldom rising above $5\frac{1}{2}$ per cent. It occurs in solution, and is not found elsewhere in nature.

Milk-sugar is the most unstable component of milk; its decomposition is brought about quickly and easily by the action of micro-organisms. If these could be entirely excluded from the milk, it would keep for an almost indefinite length of time. As it is impossible under practical conditions to entirely exclude organisms from the milk, the only way to retard and prevent the growth of germs and thereby prevent the changing of the sugar into other products, is to cool the milk to a low temperature (50°F.), or to heat the milk to a sufficiently high temperature (180°F.) to destroy most of the germs. According to Van Slyke

and Hart, the decomposition of the caseous matter produces free casein. When about .5 per cent acid has developed in the milk, the free casein combines with the acid and forms casein lactate.

The chemical composition of milk-sugar is $C_{12}H_{22}O_{11} + H_2O$. Were a perfect decomposition of milk-sugar into lactic acid to take place, the following equation would represent the change:

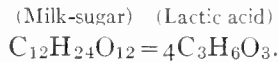

Such an ideal change, however, never takes place. In such a case, one gram of milk-sugar should produce one gram of lactic acid. In a number of experiments carried on by one of the authors of "The Analysis of Cream during Different Ripening Stages,"¹ the highest amount of acid produced from one gram of milk-sugar was .8 of a gram. This indicates that there are always accompanying by-products produced, besides lactic acid, when milk-sugar is being decomposed in cream or milk. The sourness of milk is due to this change. The by-products which accompany the production of lactic acid are many and various. The most important ones are gases of different kinds, such as carbonic acid gas (CO_2); marsh gas (CH_4); hydrogen (H); and nitrogen (N.) Small amounts of alcohol, formic, acetic, and succinic acids are said to be normal accompanying by-products also. These by-products may also partially result from the breaking down of some of the other milk components.

As milk-sugar is in perfect solution, it follows the water of milk, and in cheese-making nearly all of it passes into the whey. Commercially and chemically it is prepared from whey. It is a white, not very sweet powder, and is used for medicinal purposes to dilute pure, powerful drugs. It is also used extensively in the preparation of modified milk.

Ash.—The ash of milk is present in very small quantities, and when viewed from such a standpoint it may first seem to be of small importance. On account of the effect of the mineral con-

¹ Thesis, I. S. C., Ames, Ia.

stituents upon the properties of milk, it is one of the most important components of the milk. It exists partly in solution, and partly in suspension. Babcock maintains that about one-third of the usual ash constituents are in suspension, and that they consist chiefly of lime phosphate.

All of the minerals in milk consist chiefly of potash, lime, soda, magnesia, and iron, combined with phosphoric, hydrochloric, sulphuric, and carbonic acid. Calcium phosphate constitutes about one-half of all the ash constituents. They are named above, in order, according to the extent to which they occur in milk.

Gases of Milk.—These do not normally exist in milk to such an extent as to enable chemists to determine them quantitatively, but they are of great importance, owing to the effect they have upon the quality of the milk, viewed in the commercial sense.

Gases in milk may be divided into two classes according to their origin; namely, (1) those imparted to milk before milking and (2) those which are later formed and absorbed in milk.

(1) When freshly drawn, milk has a characteristic odor, which seems to be normal to all fresh milk. The gases which cause this odor are very volatile, and by cooling and stirring the milk can, to a large extent, be eliminated. The amount and kind of taints existing in milk, immediately after it has been drawn, largely depend upon the food which the cow has been fed. Turnips, onions, and garlic, when fed to cows a short time before milking, cause undesirable gases or taints to exist in the milk. Good hay, bran, and good grass produce milk of superior quality, containing no odors excepting those which are natural to all milk when first drawn.

The milk yielded by cows pasturing in the Alps of Switzerland is said by tourists to possess a peculiar, not undesirable, spicy odor and flavor. It is maintained by the native people in Switzerland that the peculiar flavor of the Emmenthaler cheese cannot be developed anywhere else in the world. This flavor they believe to be due to the kind of vegetation the cows feed upon in the Alpine pastures. In Denmark, the poor people

who do not own much land, graze their cows along the roads where weeds of different kinds grow. Milk from such cows has a peculiar characteristic odor or taint. In this country it is a common occurrence to find that milk delivered by patrons who keep their cows on timber-land pastures has a peculiar weedy odor. Especially is this true in the fall or late summer. If such milk is heated to 160° to 180° F., and stirred occasionally, some of these taints pass off. The addition of a small amount of saltpeter will improve the flavor of milk where such foods as turnip and sugar-beet tops are fed. This remedy is often applied to milk in Canadian cheese factories, during the fall of the year when turnip tops are fed, and also in Germany during the period of the feeding of sugar-beet tops.

Too much emphasis cannot be placed upon the food that the cows receive. While it is true that much of the desirable aroma and flavor in butter is due to bacterial growth, the kind of food fed to cows is not without significance. It is a well-known fact that districts such as Normandy and Denmark, which have become famous for their high quality of dairy products, have the best of pasture and winter feeds.

Besides the kind of food, some physiological disturbances of the cow may cause abnormal taints in milk.

(2) Gases or taints which are formed in the milk or absorbed by it are due to fermentation and absorption respectively. The former cause will be considered in a separate chapter, and the latter cause needs little explanation. It is a well-known fact that milk and most of its products have the special property of absorbing odors which may be present in their surroundings. For this reason, milk, as well as other dairy products, should at all times be kept in clean utensils and pure surroundings.

Taints appearing in milk immediately after milking are due to absorption within the cow. Taints that develop on standing are due to bacterial growth in the milk, or to absorption from impure surroundings. In the prevention and removal of taints from milk the first step is to remove the cause, and the second to eliminate as many of these taints as possible by a process of aeration or pasteurization.

Coloring-matter.—It is not known of what the coloring-matter in milk consists. A substance named lactochrome has been found in milk. So far as known, this coloring-substance is closely associated with the fat called palmitin. The amount of coloring-matter varies during the different seasons of the year. It also varies according to the different breeds. During the spring of the year, when cows are first put on grass, the color of the butter-fat is always higher than it is during the latter portion of the summer. During the winter, the fat in milk is quite pale. By feeding the cows some succulent feed in the winter, such as silage, carrots, and beets, the color of the butter-fat is rendered much higher.

From this it would seem that the change in the color of the fat with the different seasons, and with the food given, is closely associated with chlorophyl, the coloring-matter of grass.

Other Constituents of Milk.—It is said that constituents such as citric acid, urea, nuclein, lecithin, and galactase are present. Babcock maintains that he has discovered a substance named fibrin. This seems to be similar to the nuclein mentioned by Fleischmann, if not the same. But as these substances are present to a very small extent, citric acid, urea, and fibrin being present to the extent of .12, .007, and .0002 per cent respectively (Fleischmann and Babcock), they are of little importance.

CHAPTER II

MILK SECRETION

The Mammary Gland as a Secretary Organ.—The mammary gland of females belonging to the order of mammalia secretes a fluid known as milk. This substance is strictly a secretary product. There are two kinds of glands present in the animal body, viz., the *excretory* and the *secretory*. Generally speaking, an excretory gland is one which receives or absorbs the waste matter of the body, and causes it to be carried off without causing any marked change to take place in the substance excreted. A secretary gland is one in which the raw material is obtained from the blood and then manufactured into a special different product within the gland itself. As an example of a secretary gland, the milk-gland of the cow's udder is an apt illustration. The glands in the mouth secreting saliva, and those in the walls of the stomach secreting the digestive fluids, are also secretary glands.

Internal Structure of Cow's Udder.—The cow's udder is composed of two separate glands, the right and left halves. These two glands are distinctly separated from each other by a fibrous tissue running longitudinally. This fibrous partition extends along the abdomen in front, and back to a point between the thighs of the cow. It also serves to hold the cow's udder in place. There is no connection at all between the right and left glands, and consequently milk cannot be drawn from the left side over to the right, and vice versa.

Each of these right and left halves is again divided into two parts, thus making the cow's udder appear to be divided into quarters. The cow's udder may then be said to consist of two glands, one on each side, and four "quarters," two to a gland. The division between the two quarters of a gland is not complete;

that is, there is enough connection between the two to allow a portion of the milk to be drawn from the rear quarter through the front teat on the same side, and vice versa.

The milk-glands proper are located near the abdomen and extend a trifle downwards into the udder. The remainder of the

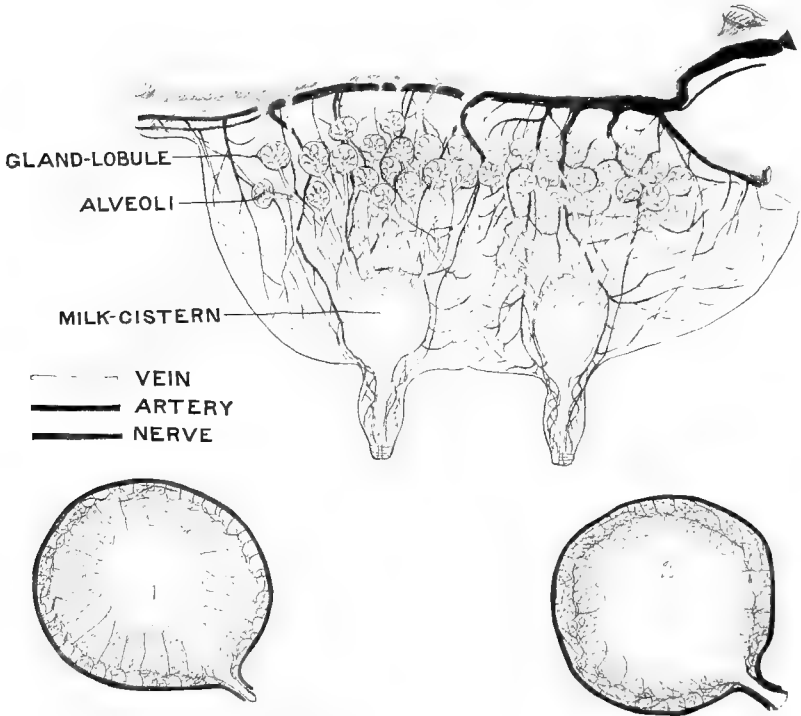

FIG. 2.—Schematic figure showing cross-section of cow's udder; and also enlargement of epithelial cells in alveoli when cow is giving milk (1). Each alveolus is surrounded with a membrane called tunica propria. Cell nuclei not shown. When cow is in milk they are also enlarged. When not the epithelial cells are flat and the nuclei small and spindle shaped (2).

udder is filled with ducts, fibrous and connective tissue, muscle, nerves, and blood-vessels, the whole udder assuming a sort of spongy and open condition.

The teat is simply a cylindrical-shaped body, with a hollow tube extending down through the center of it. At the bottom

of this opening, or at the end of the teat, there is a sphincter muscle, which in some cases is drawn up very tight, while in other instances it is so loose that it will not prevent the milk from escaping. In case the muscle is so tight that the milk can be drawn only with difficulty, it may be relaxed a trifle by inserting a small, smooth wooden plug. This will usually dilate the opening sufficiently, so that the milk may be drawn with comparative ease. In some instances this muscle is so tight that it is necessary to relax it by the use of a sharp knife. This, however, should be done with surgical skill; otherwise the whole muscle is likely to be so injured as to cause the milk to leak away at all times.

The upper part of this canal in the teat connects with what is called the milk-reservoir. The size of this reservoir varies in different cows. The average capacity of this milk-cistern is about one pint. The opening from this reservoir into the teat is also guarded with a muscle. Over this muscle the cow has little control; over the muscle at the lower end of the teat she has no control whatever.

Opening into the sides and top of this reservoir are a large number of tubes, which are called milk-ducts. These milk-ducts extend from the reservoir up into the milk-gland. They radiate in all directions, divide and subdivide, so as to form a very large number of small tubes. These milk-ducts are surrounded with fibrous muscular tissue, nerves, and blood-vessels. They are all guarded by a special muscle at the junction with the main milk-ducts, from which they radiate. These muscles are so intimately connected with the nerves and muscular system of the cow that she is able to open and close them at will. There are very few cows that are not able to hold up their milk during nervous and exciting periods. It is a common occurrence for a milker to get only a small part of the milk from a cow; this small amount is the portion which is present in the teat and milk-reservoir. Some cows are able to hold up this milk also, but the majority of cows cannot perfectly control the muscle which guards the entrance to the teat. The milk which is present in the milk-ducts and which has to pass through these junctions referred to above can be held up by most cows at will.

All of the small milk-ducts end in small sac-like bodies, each of which is called a gland-lobule or ultimate follicle. The gland-lobules enclose numerous individual microscopical bodies called alveoli or acini; these are the organs which possess the proper secretory functions. Their outer covering is a membrane called the tunica propria; within this there is an intermediate layer of cell-tissue, and an inside layer composed of cells, which are named the epithelial cells. These epithelial cells within the alveoli are supplied with blood from the cow's system. During lactation they assume a different form, swelling and extending into the cavity of the alveoli when the cow is yielding milk abundantly, and when she is not in milk the alveoli are flat. A certain number of alveoli are tributary to one particular duct leading from the gland-lobule into still larger milk-ducts.

Each aggregation of gland-lobules, tributary to one milk-cistern, constitutes a lobe, and may be likened to a side branch of a bunch of grapes. Each separate grape may represent a gland-lobule. The seeds within the grape, if we imagine each seed to be hollowed out and lined with small column-like bodies, may be likened to the alveoli. These column-like bodies would then represent the epithelial cells. The stem leading from each individual grape may represent the small duct which carries the milk on to the larger ducts. The main stems of the bunch may represent the larger ducts that enter into the milk-reservoir. The air which everywhere fills the openings or interstices of the various parts of the bunch of grapes may be likened to the fibrous fatty tissue between the alveoli and the lobules of the gland.

Theories of Milk Secretion.—Although the theories of milk secretion have been studied considerably, many things in this connection are not well understood. Previous to the year 1840 it was thought that the only function of the milk-gland was to filter the milk as it transuded from the blood. It was supposed that the quality and quantity of milk depended entirely upon the food. The theory has also been advanced that the major portion of the milk constituents is a decomposition of the product of the lymph bodies of the blood. It was believed that the lymph bodies were a source of nourishment to the fetus.

and that the calf received its nourishment from the same source after it was born as it did previous to birth. It was supposed that after the birth of the calf the opening on the uterus through which the food was supplied was closed, and that a new opening was formed in the milk-gland. These two theories have now been practically overthrown. It has been demonstrated that the major portion of the milk is formed within the milk-gland. The fat, casein, milk-sugar, and part of the albumen are supposed to be formed in the udder. This conclusion is substantiated by the fact that these substances do not appear in the blood, at least not to such an extent as to warrant the assumption that they are not manufactured in the cow's udder. The total amount of fat in the blood of the cow would not equal the fat in the milk from one milking.

By some it is maintained that the substances in milk which are found in solution may be transuded directly from the blood. Here again milk-sugar is found to be in perfect solution in the milk. But this substance can be found nowhere in nature besides in milk. It is not present in the blood of the animal; consequently it must be manufactured within the gland itself. The water of milk, and the ash constituents which are in solution, are probably transuded directly from the blood. No attempts have been made to determine definitely how casein and albumen are formed within the gland.

According to the theory which has been advanced, the fat is formed by the breaking down of the epithelial cells. When the breaking-down process is completed, the transformed cells appear at the opening of the alveoli in the form of distinct fat-globules. This is supposed to be the origin and formation of fat-globules in milk; so it may be said that so far as known the fat is the result of a breaking down of degenerated epithelial cells.

Dr. Bitting asserts that the formation of milk solids in the cow's udder is probably due to a metabolic process rather than to a degenerative. Collier found that a cow giving a normal amount of milk would secrete about 136,000,000 fat-globules per second. He also suggests that a cow secretes about 5 pounds of milk solids per day. As a cow's udder weighs only about $2\frac{1}{2}$

pounds, the whole udder would have to be renewed twice daily. This is not consistent with our present knowledge of tissue building.

The chief incentive to milk secretion is maternity. As soon as the young mammal is born the blood which went to the uterus to supply the calf is turned toward the udder instead.

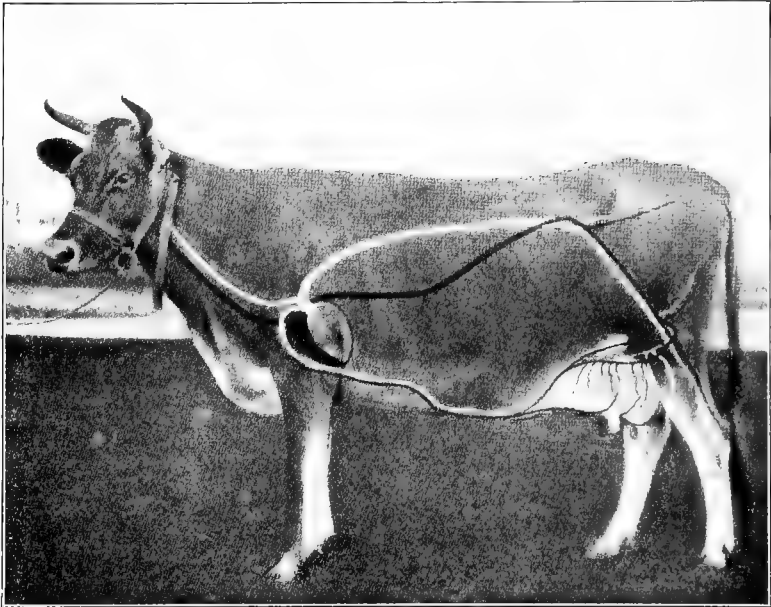

FIG. 3.—A schematic figure showing the course of the artery leading to the mammary gland and the veins returning to the heart. The light-colored lines represent arteries and the dark-colored lines the veins. (From Bitting, Twelfth An. Report, Indiana.)

As soon as this current of blood begins to flow, all of the blood-vessels and capillaries in the cow's udder swell. This causes the minute blood-vessels or capillaries which form a network in the walls of the alveoli to swell, and their swelling stimulates the epithelial cells to activity.

Conditions Affecting Secretion of Milk.—There are a great many conditions which affect the milking capacity of a cow. These conditions may be conveniently grouped into two classes

according to their causes: (1) conditions which are controlled largely by man, and (2) conditions which are inherent in the cow.

1. Some of the chief conditions which reduce the secretion of milk and are largely controlled by man are: improper care and treatment of the cow, lack of proper food, incomplete and improper milking, irregularity, and long periods between milkings. Pregnancy, nervousness, or excitement of any kind affects the proper working of the milk-glands considerably. These latter causes, however, are not always controlled by man.

2. Without denying the influence of those conditions mentioned above, the conditions which chiefly affect the milk-secreting capacity are inherent. It does not matter how much good care and food a cow receives, if she does not possess these inherent necessary qualities. As was mentioned before, the milk-secreting capacity depends upon the *number of gland-lobules, the amount of blood which is supplied to these secretory parts, and the capacity of the cow to digest and assimilate food*, and possibly upon a stimulating body fluid not yet well understood.

The number of gland-lobules is believed to increase until the cow is about seven years old. The milk-secreting glands are present only in a rudimentary form, until the cow has had her first calf, or is well advanced in the first stage of pregnancy. The gland-lobules then increase in number up to the age of about seven. The relative number of lobules in the cow's udder can only be approximately ascertained. The size of the udder in some measure indicates this. A cow with a large flexible udder is usually a good milker, due to the fact that a large udder usually contains a large number of gland-lobules.

The amount of blood which is turned through the cow's udder to supply the milk-secreting cells may be approximately ascertained by the size of the blood vessels. The blood from the heart enters the udder near the region of the hips. It then passes down through the udder, along the abdomen just beneath the skin, until it reaches a point about midway between the flank and the girth. At this place it penetrates the abdominal wall and enters the thorax. The place at which the blood penetrates the abdom-

inal wall may be felt with the finger. It is supposed that the size of this hole is in some measure indicative of the milk-producing capacity of the cow. This opening in the abdominal wall is called the milk-hole or milk-fountain. Large irregular veins are considered a much better indication of good milking properties than small straight veins.

The formation of gland-lobules is entirely inherent in the cow. The only way that these may be increased is through selection and breeding. The amount of blood which passes through the cow's udder is also largely inherent, although this may in a small measure be affected by the amount and quality of food given to the cow. It should at all times be remembered that a cow is not a mere receptacle into which so much food can be introduced, and from which so much milk can be drawn. After giving due credit for the influence of all other conditions, we must still recognize that the inherent conditions affecting the secretion of milk are the most important.

External Appearance of the Udder.—A cow's udder should be well and symmetrically formed. It should be square and wide, and extend well along the abdomen of the cow, and back up between the thighs. When the udder is empty it should be soft and flexible. The teats should be medium large, be placed well apart, and point downwards.

There should be little or no depression in the udder between the teats; that is, each quarter should not appear distinct and separate when viewed from the exterior.

The cow's udder should be covered with fine, soft, downy hair. A light golden yellow is said to be indicative of a good quality of milk.

A firm, fleshy udder is undesirable. In the first place, it is not indicative of good milking qualities, and, secondly, such an udder is predisposed to inflammatory diseases.

Milk-fever.—This is a common disease in fresh cows. It is due to a congested condition of the cow's udder. The decomposition products of the colostrum milk in the udder are absorbed by the blood, and produce the characteristic symptoms of milk-fever. Dr. Peters, of the Nebraska Experiment Station, says that a good

and simple remedy for a diseased udder is to pump it full of air. This can be accomplished with an ordinary bicycle pump. After some air has been pumped in, the cow's udder should be worked or massaged with the hand so as to cause the air to pass through the quarter. He claims that the udder can thus be restored to its normal condition very quickly, thereby preventing and even curing milk-fever. In case the udder is caked very badly, apply a hot poultice. Small five- or ten-pound bags filled with bran and kept hot will prove very satisfactory. A compress consisting simply of a piece of heavy cloth is also used. It should be put on so that it lifts up the entire udder, and tied over the back of the cow. Straw should be put underneath it on the back so that the cord will not injure the animal.

CHAPTER III

PROPERTIES OF MILK

Color.—The coloring matter of milk is associated with the fat. According to extensive investigations, made by Eckles and Palmer at the Missouri Station, this color is due to *carotin*, so called because it is the coloring matter of the carrot. It is found in green plants and is closely associated with the chlorophyl, which hides its presence. It is not manufactured by the animal. Animals which produce milk rich in fat, in the form of large fat-globules, possess the ability to utilize this coloring matter to a greater degree than do animals which produce milk having a lower fat content and smaller fat-globules. This explains the downward gradation of the color of the fat in the milk as we pass from the Guernsey and Jersey to the Shorthorn, Ayrshire and Holstein breeds.

Flavor.—Milk has a sweet flavor, and a faint odor. Fresh milk has a peculiar taste and odor, which pass off when it is exposed to the air. The flavor is affected by foods and conditions of the cow, as mentioned under "Abnormal Milk."

Opacity of Milk.—Milk is opaque, except when seen in very thin layers; then it is slightly transparent. The opacity of milk is due to the presence of the fat and nitrogenous matter. When these substances are filtered away on a fine clay filter (the Chamberland), the filtrate which passes through is clear and transparent. It has been maintained that the fat in milk is the chief cause of its opacity, and that the percentage of fat could be determined according to the degree of opacity and transparency of milk with an instrument named pioscope; but it was soon found out that the size of the fat-globules, as well as the number, had considerable influence upon the degree of opacity of milk. For that reason, this method of determining the amount of fat in

milk was not reliable. The fat-globules themselves are said to be almost transparent, yet the color and opacity of milk is largely due to their presence. This characteristic may perhaps be explained by assuming that the fat-globules in milk deflect the light instead of allowing it to pass through them.

After the fat has been removed, the milk still continues to be opaque. When the albuminoid matter has been removed and filtered off the filtrate becomes clear and transparent.

Chemical Reaction of Milk.—Milk when fresh shows an amphoteric reaction, which means that it exhibits both an alkaline and an acid reaction when tested with litmus paper. It turns blue litmus paper red, and red litmus paper blue. This peculiar behavior of milk is said to be due to the caseous matter in the milk, which itself has an acid reaction, while the remainder of the serum has a slight alkaline reaction. By testing the reaction of fresh milk with a tenth normal alkali solution, and using phenolphthalein as an indicator, an acid reaction is obtained. After standing, milk soon becomes distinctly acid, due to a change of the milk-sugar into acids, chiefly lactic acid, through the action of micro-organisms. Richmond maintains that the amphoteric reaction of milk has acquired a false importance, as he believes that the neutrality, as measured by the action of litmus paper, is not chemical neutrality.

Specific Gravity of Milk. -By specific gravity of milk we mean the weight of the milk as compared to that of an equal volume of water at the same temperature. If a certain volume of water weighs 1000 pounds, an equal volume of milk at the same temperature and under the same conditions will weigh about 1032 pounds. Reducing the figure to a basis of 1, as is always done, the comparison between the two equal volumes of water and milk will be 1 and 1.032. This latter figure represents the average specific gravity of normal milk.

It can be readily seen that the correct specific gravity can be obtained only at one given temperature, for, as the temperature of the substance becomes higher, the density of it grows less, and consequently the specific gravity will be less. The temperature at which the lactometers are standardized is 60° F.

The specific gravity of milk will also vary according to the relative variation in amounts of the different components. If a sample of milk is rich in solids not fat, as, for instance, skimmed milk, the specific gravity will be high and usually between 1.033 and 1.037. If the sample of milk is rich in fat, as, for instance, in cream, the specific gravity will be less.

The specific gravity of milk is lessened by the addition of water. Owing to this fact it was first thought that adulteration of milk with water could be detected by testing its specific gravity. But this method was soon found to be erroneous, as it is possible to take cream away and add water in such a proportion as not to alter the specific gravity of the sample. A low specific gravity may, however, cause the suspicion that the milk has been adulterated, and the test for water adulteration can be supplemented by testing it for fat.

As has been mentioned before, the lactometer reading should be taken at 60° F. If the temperature of the milk is above or below, corrections must be made. The amount of correction which will give approximate results is .1 of a degree added to the lactometer reading for every degree Fahrenheit of temperature above 60° F., and .1 of a degree subtracted from the lactometer reading for every degree of temperature below 60° F. The temperature of milk when tested for lactometer reading should never go any lower than 10° below 60°, nor any higher than 10° above 60°. This would leave the range of temperature between 50° and 70° F.

In chemical laboratories, the specific gravity of milk is usually determined by the use of a picnometer.

In practice there are three instruments in general use for determination of lactometer reading, or specific gravity, viz., Quevenne lactometer, New York Board of Health lactometer and the ordinary hydrometer. The Quevenne lactometer is the one that is used chiefly in creameries. The graduation of each one of them is given in the accompanying diagram. It may be seen from the figures that in order to change the Quevenne lactometer reading into specific gravity, all that is necessary is to add 1000 and divide the sum by 1000. In changing the

specific gravity into lactometer reading the reverse process will give correct results.

The hydrometer gives the specific gravity directly. The Board of Health lactometer has a special graduation. When this lactometer was devised it was thought that 1.029 was the minimum specific gravity of unadulterated milk. The scale on this lactometer was made from zero to 120, zero marking the point which represents the specific gravity of water, namely, 1, while 100 is the point which is assumed to represent the least specific gravity of milk, 1.029. If the specific gravity of a certain sample of milk fell to 90, it indicated that there was 10 per cent of water present. If it fell to 80, it indicated that there was 20 per cent of water, etc.

In order to calculate the total solids, and solids not fat, of milk, it is necessary to know its lactometer reading, and the percentage of fat in it. Knowing these factors, by the use of the following formula given by Farrington and Woll, and deduced from Fleischmann's work, the total solids, and solids not fat, can be found.

$$\begin{aligned} \text{Solids not fat} &= \frac{1}{4} \text{ lact. reading} + .2 \text{ times the fat.} \\ \text{Total solids} &= \text{fat} + \text{solids not fat.} \end{aligned}$$

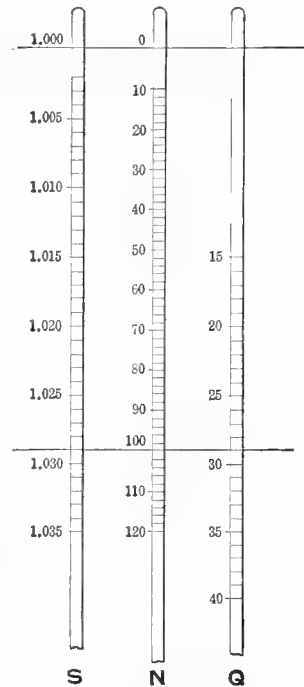

“S” Specific Gravity Scale.
 “N” New York State.
 “Q” Quevenne.

FIG. 4.—Comparative graduation of lactometer stems.

Natural Separation of Milk and Cream.—When milk is allowed to stand quietly for a short time, a layer having a rich-yellow color comes to the surface. This is the cream, and contains most of the fat. This separation is due chiefly to the

difference in weight, or specific gravity, of the fat-globules and the serum. The force which acts upon the globule of fat is the difference in weight between the fat-globule and the serum which it displaces, minus the resistance with which it meets in its upward passage. This force is great in milk with a high degree of viscosity and slighter in milk of a limp and liquid consistency.

While the addition of water to milk reduces its viscosity it also lowers its specific gravity. Hence, the so-called "dilution cream

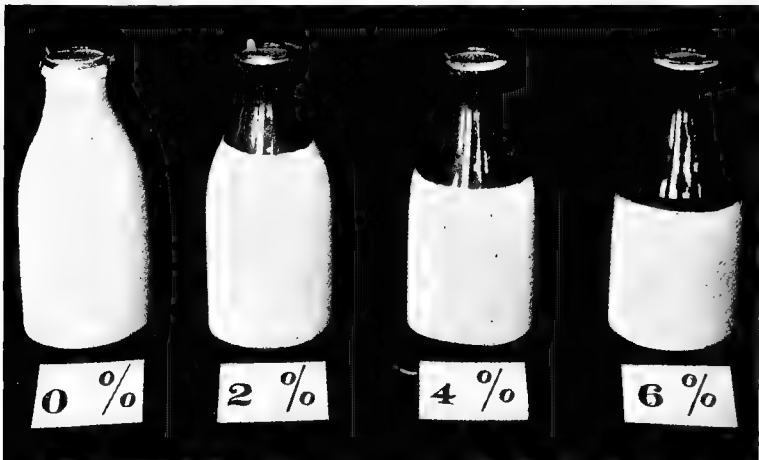

FIG. 5.—Standardized milk. Showing the amount of cream on milk containing the designated per cent of butter-fat. (From Bul. 92, Ill.)

separator" has, generally speaking, little to recommend it. While the skim-milk may give a lower test we must remember that there is a greater quantity of it. Furthermore, it lacks the palatability and feeding value of undiluted skim-milk. But this is a point that need not be labored, since the hand separator has all but superseded the different methods of setting milk.

In normal milk, the amount of fat left in the skimmed milk by natural creaming is about .4 per cent. The fat which is left in this skimmed milk is largely composed of very small globules. This is due to the fact that the resistant force on these small globules is equal to or greater than the buoyant force acting upon them.

The completeness of natural skimming is to a certain extent based upon the mathematical law which is stated as follows: "The surfaces of two spheres are to each other as the squares of their diameters, and their cubical contents are to each other as the cubes of their diameters." The larger the globules are, the greater the surface is, and the greater the resisting force to which they are subjected. From the law stated it can be seen that as the size of the globule increases, the cubical content increases more rapidly than the surface. If a fat-globule were split up into smaller ones, there would be more surface exposed to the serum than was the case while the fat was present in one globule.

For illustration, suppose two globules of fat to have diameters of 4 and 2 inches respectively. The squares would be 16 inches and 4 inches respectively; their cubes would be 64 inches and 8 inches respectively. It will thus be seen, according to the law quoted above, that the larger globule has a surface only four times as great as that of the smaller one; but the cubical content of the larger globule is eight times that of the smaller one. This illustrates why the large globules rise in cream more quickly than the small ones. In this particular instance the upward force the larger globule is subjected to is eight times greater than that of the smaller one, while the resistant force is only four times as great as that of the small one.

Adhesion of Milk.—Normal sweet milk adheres to wood, glass, and metals to a greater extent than does water. Whole milk has greater adhesive properties than skimmed milk. A paper moistened with milk or cream makes a label that will stick to any dry object; the same paper moistened with skimmed milk has less adhesive power. The adhesive properties of milk are also due to the condition of the nitrogenous matter. This fact is made use of in painting and whitewashing. Slaked lime, when mixed with buttermilk, or milk of any kind, gives a white-wash which will remain on objects much longer than that made by mixing with water.

Viscosity of Milk.—Milk is more viscous than water. The degree of viscosity of fresh milk varies chiefly with the tempera-

ture and fat content. So far as understood, the lower the temperature, the greater the viscosity. Development of acid, and high temperature lessen the viscosity of milk. Pasteurized milk or cream is less viscous than the same milk or cream unpasteurized. This lack of body can again be restored by adding a little viscogen, as recommended by Babcock and Russell. It is not advisable to use it, however, as it does not add materially to the nutritive value of milk, but merely restores the body.

The great viscosity of thick cold cream makes it difficult to churn, as most butter-makers have discovered. It adheres to the inside of the churn and simply rotates instead of being agitated. Cream that is cold and thick whips more easily than thin, warm cream, as the viscosity is so great that the air incorporated cannot escape so easily. In ice-cream making, for the same reason, a greater yield is obtained by using cold, thick cream.

Specific Heat of Milk.—The specific heat of milk is less than that of water; that is, it requires less heat to warm a definite amount of milk to a certain temperature than it does to heat the same quantity of water to the same temperature. It also takes less ice to cool the same volume of milk to a certain temperature than it does to cool the same quantity of water to the same temperature. The specific heat of milk is, according to Fjord, .94. The specific heat of cream is about .7. It varies according to the percentage of fat in the cream. The specific heat of butter is about .4. From these figures it will be seen that it takes less heat to warm milk, cream, and butter, and less cold to cool the same substances, than it does to heat and cool water; but it takes a longer time to heat or to cool milk, cream, and butter; that is, the milk, cream, and butter are not as rapid conductors of heat and cold as is water.

The maximum density of milk is not reached, like that of water, at 4° C. but at about .3° C. The boiling-point of milk is a trifle higher and the freezing-point a trifle lower than that of water.

Effect of High Heating (180° and above) on Properties of Milk.—The chief effects of heat upon milk may be summarized in the following headings:

- (1) It destroys nearly all germs present in the milk.
- (2) It diminishes the viscosity, or body.
- (3) It drives off gases.
- (4) It imparts a cooked taste (especially if not heated and cooled properly.)
- (5) It precipitates some of the albuminoids and ash constituents.
- (6) It destroys the properties of enzymes present in milk.
- (7) It divides or splits up the clusters and fat-globules.
- (8) It caramelizes some of the sugar.

1. Destroys Nearly all Germs.—Heating milk to a temperature of about 180° F. for ten minutes destroys most of the germs present. This is the temperature used in most creameries for pasteurization. The details concerning the different effects of temperature upon growth of germs properly comes under the heading of bacteriology, and will be referred to more in detail in the chapter on “Ferments in Milk.”

2. Diminishes the Viscosity, or Body.—Heating milk or cream diminishes its viscosity; that is, it lessens the body or consistency; and in cities where milk or cream is sold directly to consumers, heated milk appears as if it had been adulterated. This diminution in the body is claimed to be due to a breaking up of the clusters, and the fat-globules and the caseous matter. The chemical union of some of the calcium salts and the casein is altered or destroyed.

The consistency of milk or cream can be restored by adding a substance named viscogen. Russell and Babcock¹ advise this method of overcoming the apparent defect caused by heating. It consists of making a strong solution of cane-sugar and mixing it with freshly slaked lime. This mixture is allowed to stand, and the clear solution coming to the top is the viscogen, which, when drawn off and used in the proportion of one part of viscogen to from 100 to 150 parts of cream, restores its body. This is due to the fact that viscogen causes the fat-globules to cluster together again, and the lime in the viscogen may combine with the

¹ Bulletin No. 54, Wisconsin, 1896.

nitrogenous constituents in such a way as to aid in the restoration of the body of the cream or milk.

Nearly all dairy laws forbid the addition of any foreign substances to milk or cream. If viscogen is added, Babcock and Russell suggest that it be named visco-milk, visco-cream, etc. When the modification is made, no objection can be raised to its legitimate use.

3. Drives off Gases.—When milk is heated, taints and gases of different kinds pass off to some extent. This is facilitated by

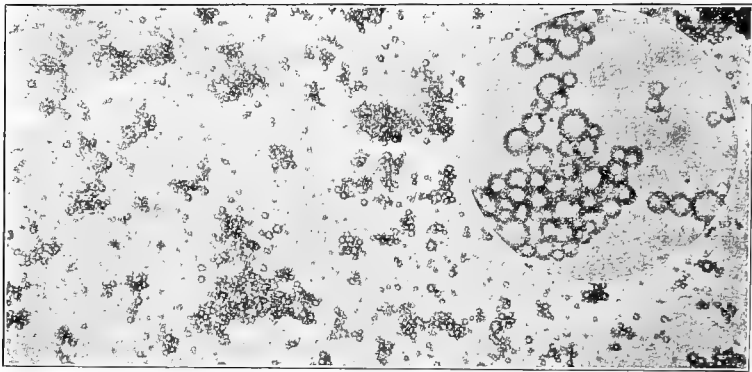

FIG. 6.—Microscopic appearance of milk, showing natural grouping of the fat globules. Single group in circle, highly magnified. (From Bul. 64, Wis.)

heating and stirring in an open vessel. Many of these gases also escape when milk is aerated and cooled in a pure atmosphere.

4. Imparts a Cooked Taste.—When milk is heated to 160° F. or above, it assumes a distinctly cooked taste, which makes it disagreeable as a food for many people. On this account, milk for city supply in America is not generally heated above 145° F. In practically all cities where milk is consumed directly, it is subjected to low temperature pasteurization (145° F.) and held at this temperature for twenty to thirty minutes. Under this system the disadvantages of high pasteurization are overcome.

For butter-making purposes there are no objections to pasteurizing cream at a high temperature. The common practice

in most of our up-to-date creameries to-day is to pasteurize the cream, under the vat or holding system, to 170° F. or above, or, under the flash system, to at least 180° F.

The reason why this cooked flavor is found in milk when heated is not well understood. It is supposed to be due to the effect which heat has upon the nitrogeneous constituents and the sugar.

5. Precipitates Albuminoid and Ash Constituents.—When milk is heated, there is a tendency for the soluble salts and a portion of the albuminoids to be thrown down, or changed into an insoluble form.

The higher the milk is heated, the greater is this tendency. If a sample of milk in a flask is subjected to intense heat, and then allowed to stand, a fine white sediment will be deposited on the bottom. This is believed to consist of minerals precipitated from the milk.

When milk has been heated to about 170° F., and cooled, rennet is unable to precipitate the curd in a normal way. The curd resulting from adding rennet to pasteurized milk is flocculent in nature. It does not assume that smooth and even texture that curd from raw milk has when precipitated with rennet. The behavior of pasteurized milk towards rennet can be rendered normal by adding a small quantity of calcium chloride (CaCl). Whether this would affect the quality of cheese materially has not yet been determined definitely. According to G. Fascetti,¹ if pasteurized milk is used for cheese-making, the cheese ripens more slowly than when made from raw milk. The same investigator also claims that a larger quantity of cheese is obtained per 100 parts of milk when pasteurized milk is used.

6. Destroys Properties of Enzymes.—As was mentioned in the chapter on the composition of milk, there is a substance normal to milk named galactase. This is an enzyme. By heating milk to about 175° F. the properties of the enzyme are destroyed. Owing to this it is easy to determine whether a certain sample of milk has been pasteurized or not. Galactase is present in milk in

¹ Exp. Sta. Record, Vol. 15, No. 10, 1904.

so small a quantity that it cannot be determined quantitatively, but only qualitatively.

A very sensitive and reliable test for determination of the efficiency of pasteurization was invented by Storch a number of years ago. This is fully described in Chapter XV on "Pasteurization."

7. Divides the Clusters of Fat-globules.—The fat-globules in normal milk are grouped in minute clusters. When milk is heated, these clusters break up, and each globule exists more or less independently. When heated to an excessively high temperature, and exposed to this temperature very long, the fat-globules tend to run together. This can be proved by heating milk in an open vat for about half an hour. A small amount of yellow fat will then be seen floating on the top.

8. Caramelizes the Sugar.—The brownish color which the milk assumes when it is heated excessively is due to a change which the milk-sugar undergoes. Fleischmann claims that the sugar begins to change into a substance known as lacto-caramel at a temperature of 160° F. This change, however, is not pronounced enough to be apparent in the color, unless the milk is heated a long time. The higher the temperature is, and the longer the milk is exposed to the heat, the more pronounced is the change.

General Remarks.—While all of the above changes have been found by investigators to take place when milk is heated, they can, in a measure, be avoided, if special precautions are taken in the heating and cooling with the special, recently improved forms of apparatus for these purposes.

The present common practice of heating milk, for consumption as such, to 145° F., and holding at this temperature for twenty to thirty minutes, is accomplished without materially changing its chemical or physical properties, or imparting to it a flavor that is at all objectionable.

CHAPTER IV

MILK AND ITS PRODUCTS AS FOODS

HIGH VALUE OF MILK-FAT

THERE are two methods for the classification of foodstuffs for animals and man, and both of these will be briefly considered in this chapter, with special reference to milk and its constituents—particularly milk-fat—as not only valuable but indispensable parts of the dietary.

The older method may be spoken of as the *chemical method*. It considers and classifies foods largely in accordance with their content of water, protein, carbohydrates, fats and mineral matter. This, in itself, is quite incomplete, as will be shown later.

The newer method, which is known as the *biological method*, is based upon a study of the properties and values of the different foodstuffs, through feeding them and noting their effect upon growth, health and reproduction. This method, though comparatively new, has made very rapid strides, and has established the fact that food constituents which come under the same chemical head are by no means either alike or of equal nutritive value.

There is neither the hope nor the expectation that the biological will supersede the chemical classification of foods and foodstuffs, in the sense of dispensing with the aid of chemistry. The true, unbiased student of the problems of nutrition recognizes two things; first, that the chemical method has rendered and will continue to render a very large service, and, second, that in itself it is too mechanical and incomplete.

In the last analysis, the biological classification of foodstuffs must prevail, but this does not mean that it and chemistry are at variance with each other. Rather it means that there must be a merging of the chemical into the larger or biological method, and that in future a larger, fuller, more intelligent and less

mechanical use will be made of chemistry as an aid in determining the values of the different foodstuffs and how they may best be combined with each other in the compounding of more economical and complete rations and diets on which animals and man will grow and thrive. At times the biological study of foodstuffs may move in advance of chemistry, as it has already done in discovering the presence in milk-fat of a fat-like or fat-soluble substance, as yet unidentified, which renders this fat altogether superior to other animal and vegetable fats lacking this growth and health-promoting foodstuff. It is the province of chemistry to ascertain, if possible, what this substance is. The same may be said of a water-soluble substance which is not nearly so limited as to its sources, being present in sufficient quantity in cereal grains and most of the mixed diets.

CHEMICAL CLASSIFICATION OF MILK AND ITS PRODUCTS AS FOODS

From the chemical standpoint, the constituents of the food material consumed by animals and man are classified under the heads of water, combustible matter and ash, mineral matter or salts—all three terms being applied to the last class.

The combustible matter includes the carbohydrates (such as starches and sugars), the fats (such as milk-fat, olive oil and other plant oils, and meat-fat), and the proteins (such as the curd of milk, the gluten of wheat and the muscle fiber of lean meat).

The carbohydrates and fats are largely burned to supply heat and energy, and are also used for the making of fat in the body and in milk.

The proteins are used, in part, for the same purposes as the carbohydrates and fats, but their distinct function, which these latter cannot perform, is that of supplying material for the making of muscle and other body tissue, and the protein of milk.

The ash or mineral matter is used for making bone, regulating the heart action and the elasticity of the muscles in general, and preventing acidity of the blood and tissues.

Under the older classification of foods we find that milk

and its products are given a very high place, on account of their high content of the different foodstuffs or constituents, and their high degree of digestibility. A quart of average milk is considered by such high authorities as Sherman of Columbia University to be approximately equal in food value to a pound of steak, or eight or nine eggs. He is here referring chiefly to their heat and energy value and high degree of digestibility.

American cheese (a Cheddar cheese) may be regarded, in a very large sense, as a concentrated form of milk, as it contains most of the milk constituents, excepting the sugar. It has about twice the food value of average meat. On this point Sherman says "Generally speaking, cheese sells at no higher price than the ordinary cuts of meat. It is a fair general estimate that a given amount of money spent for American cheese will buy about twice as much food value as it would if spent for meat."

Altogether apart from a distinctive and most important function which will be considered later, butter has a very high heat and energy value—a pound being equal to about five quarts of average milk. It is by no means merely a relish, as it has in the past been considered by many.

We cannot here afford the space to discuss the food values of the various other milk products, such as cream, ice-cream and condensed milk. It will suffice to say that cream occupies an intermediate position between milk and butter, combining the features of both.

BIOLOGICAL CLASSIFICATION OF FOODS

The High Value of Milk and Milk-fat under this Classification

The biological study of foods—based upon observations as to the influence of various foodstuffs upon the growth and thrift of animals—has revolutionized our ideas with regard to problems of nutrition, and has established the fact that the biological classification of foods is the true one. In doing so it has shown that milk and milk-fat have values as foods which, a few years ago, were quite unknown, and which as yet have not been determined chemically—or at least have been determined only in part.

It was but natural that biological students of the problems of nutrition should give their attention to milk and endeavor to ascertain wherein its different constituents excelled the corresponding constituents of other foods. Knowing that the young grow and thrive on a diet composed exclusively of milk, they realized that this food must contain nutritive material of an exceptionally high order.

Proteins

The proteins of plants differ from those of animals and of each other. Animals do not take the proteins of their foods, whether of plant or animal origin, and use them as such, without any change. In the processes of digestion and assimilation, animals break proteins up into the simpler substances, amino-acids, and from these build up the proteins of the muscle and other tissues of the body.

There are eighteen amino-acids that are considered in nutrition problems. The protein of wheat (gluten) is able to supply only a limited number of these in sufficient quantity, and some not at all. The proteins of the corn kernel (zein, etc.) are able to supply others, and so on with the proteins of the different foods; but none of these is a complete protein food for the animal body. The chief protein of milk (casein) is, however, an exception, being a very complete and well-balanced protein, which is able to supply the different amino-acids in sufficient quantities and right proportions to build up muscle and other protein tissue of the body. Thus we would say that milk furnishes protein of a quality quite superior to that of almost any other food. This we see exemplified in the fact that the young animal lives, grows and thrives on milk alone.

Ash or Mineral Matter

In the ash or mineral matter of the food there must be a sufficiency of such elements as sodium, potassium, calcium, magnesium, iron, etc., in the form of inorganic salts. These perform very important functions. Each has its work to do, and they are not interchangeable.

In a mixed diet, there is usually, but not always, a sufficiency of the compounds of the different elements mentioned. We quote Sherman upon this point: "There must also be maintained in the body a proper balance between sodium and calcium (the metal of lime). For example, the rhythmical contraction and relaxation of heart muscle, which constitutes the normal beating of the heart, is dependent upon this muscle being bathed by a fluid containing the proper concentration and quantitative proportions of sodium and calcium. Calcium is not always sufficiently abundant even when the food is freely chosen; hence the richness of a food in calcium is a factor affecting its value."¹ McCollum and Simmonds found as a result of their experiments, "that the deficiency in mineral elements in wheat and other seeds is limited to three elements, calcium, sodium and chlorine."²

The ash of milk is present in liberal quantity, is of high quality and well balanced, and is rich in its lime content as a source of calcium. There is more lime in a pint of milk than in a pint of limewater.

Two Unidentified but Essential Food Substances—One of These in Milk-fat but not in Ordinary Fats

There are, in association with some of the foodstuffs, substances which have not as yet been identified chemically, possibly on account of the minute quantities in which they are present; and yet observation, in feeding experiments, has shown that they are indispensable. If these are absent from their foods, animals will neither grow nor retain vigor.

As early as 1906, Hopkins of Cambridge (England) showed conclusively that on an apparently complete food made up of purified proteins, ordinary fats, carbohydrates and salts young rats would not grow, but that when a very small amount of milk was used—enough to make up about 4 per cent of the dry matter of the food—growth became entirely satisfactory. This led him to conclude that there were present in milk unidentified food substances which he termed "accessory" articles of the diet.

¹ Food Products, pp. 19 and 20.

² The Newer Knowledge of Nutrition, p. 23.

These would be what McCollum terms the "fat-soluble A," which is found in milk-fat but not to any appreciable extent in the ordinary fats, and the "water-soluble B," which is more generally distributed in foods, particularly in diets of mixed foods.

Bloch, a Danish physician, observed about forty cases of severe eye trouble, accompanied by ulceration, in children near Copenhagen. This would, without doubt, have ended in blindness. These children had been receiving skim-milk, instead of whole milk, in their diet, and were practically deprived of milk-fat in their food. When the younger of them were given mother's milk, and the older either cow's milk or cod liver oil, they responded and recovered. He attributed the trouble to the lack of fat in their foods; but it will be noted that in all cases the real cause of recovery was the feeding of fats containing the, as yet, unidentified fat-soluble which is present in the fats of milk, the yolk of egg, the liver and other body glands, and the leaves of plants, particularly such plants as alfalfa and the clovers.

Mori found fourteen hundred cases of similar eye trouble amongst children in Japan; these responded to the feeding of chicken livers.

It has been found both by McCollum and Davis, and by Osborne and Mendel that milk-fat contains a fat-like or fat-soluble substance whose presence or absence in a food, otherwise entirely satisfactory, means the difference between growth and no growth in the young. In addition to this, both these pairs of investigators found that, deprived of such a fat as milk-fat, the young animal would develop a disease of the eyes which would ultimately cause blindness and, if persisted in, would end in death; but that if this fat were restored in time the eyes would become normal again and the young animal would return to its former health and vigor and resume normal growth.

It would be unfair to credit any one man, or set of men collaborating with each other, with the discoveries that have been made during the past fifteen or twenty years—and particularly within more recent years—through the biological study of foods. The list of investigators is rather a formidable one,

and, as has already been indicated, includes students of the subject extending from America to Europe and even to far-away Japan. Without doubt the best known of these in America is Dr. E. V. McCollum, whose extensive and most valuable articles appeared in Hoard's Dairyman and other farm and scientific journals, and who has issued a valuable book on the subject, entitled, "The Newer Knowledge of Nutrition." In this book he outlines the investigations conducted by him and his co-workers—Babcock, Hart, Davis, Steinbeck, Humphrey, Parsons, Funk, Kennedy, Simmonds and Pitz—and also familiarizes us with the work of many other investigators.

As McCollum intimates, in order to secure reliable and exact data it was necessary to feed purified foodstuffs (purified protein, carbohydrates, fats and mineral salts), and in order to do this and secure sufficient data within a reasonable time it was necessary to experiment with small animals. For these reasons, the experiments were conducted mostly with young rats, although like results were also obtained with other animals, including cattle and pigs. *Accumulated data, from a variety of sources, show that the results secured are equally applicable to the different animals, including man.*

In one of the earlier experiments with rats, conducted by McCollum and Davis, they fed a diet composed of purified protein (casein) to the extent of 18 per cent, lactose or milk-sugar 20 per cent (supposed to be pure), about 5 per cent of some fat, together with a salt mixture made up in imitation of the mineral matter of milk, and the balance of starch to make up 100 per cent. The results of this experiment were that when the fat used was milk-fat growth could be secured, but that when this was replaced by such fats as lard, olive oil or other vegetable oils, there was no growth. When the fat of yolk of egg was used instead of milk-fat it also induced growth. These experiments established the fact that fats from different sources are by no means equal in dietary value.

Following this a more elaborate experiment was planned and carried out by McCollum and Davis. It will be noted that the diet of purified foodstuffs, which proved a satisfactory one, was

made up of purified milk constituents. McCollum and Davis next tried the wheat seed or kernel. They reasoned that it contained protein, carbohydrates and mineral salts and fats or oil, and that if these were mostly equal in quality to those of milk the only foodstuff that might have to be added would be a growth-promoting fat. They first fed wheat alone and then tried the improvement of it with respect to one dietary factor at a time. The following indicates the different combinations in which wheat was fed, with results secured:

- (1) Wheat alone. No growth, short life.
- (2) Wheat, plus purified protein. No growth, short life.
- (3) Wheat plus a salt mixture which gave it a mineral content, similar to that of milk. Very little growth
- (4) Wheat plus a growth-promoting fat (milk-fat). No growth.
- (5) Wheat, plus the protein, plus the salt mixture. Good growth for a time, few or no young, short life.
- (6) Wheat, plus protein, plus a growth-promoting fat (milk-fat). No growth, short life.
- (7) Wheat, plus the salt mixture, plus the growth-promoting fat (milk-fat). Fair growth for a time, few or no young, short life.
- (8) Wheat, plus protein, plus the salt mixture, plus a growth-promoting fat (milk-fat). Good growth, normal number of young, good success in rearing young; life approximately the normal span.

This series of experiments again proves the necessity of a growth-promoting fat. But it does more than this; it shows that the proteins and mineral matter from different sources are not of equal value, those of milk being altogether superior in this respect to those of such a food as wheat. Other experiments proved that the seeds of other cereals are, like wheat, quite incomplete in themselves as diets.

In following up this investigation it was found that when polished rice was substituted for wheat, in No. 8 of the series of experiments just outlined, the diet failed utterly to induce growth. This was puzzling. The investigators had been able to induce successful growth through feeding a diet composed of

purified protein (casein), milk-sugar (supposedly pure), salts in imitation of the mineral matter of milk, and milk-fat. They could see no reason why the polished rice, supplemented by purified protein, suitable salts and milk-fat should not be a complete food. This was cleared up subsequently by establishing the fact that the milk-sugar used in the former of these two experiments, and the germ or chit of the cereal seeds, which had been rubbed off the rice, contain a water-soluble substance essential for growth, health and vigor.

The conclusions finally reached were, first, that amongst the food substances (protein, carbohydrates and ash or mineral matter) coming from different sources there is a marked difference in quality, and that those from milk are of a very high order; and second, that there are two as yet unidentified substances which are indispensable to growth and health, namely, the unknown substance which is present in milk-fat, the fat of yolk of egg and some of the glandular fats, which McCollum and Kennedy subsequently designated "fat-soluble A," and a second substance soluble in water, which they designated "water-soluble B." The absence of the former (fat-soluble A) not only prevents growth, but also causes a serious eye trouble which, if not corrected in time, will end in blindness and death. We have already illustrated this point. The absence of the water-soluble also prevents growth, and causes serious physiological disturbances resulting in a form of paralysis, beri-beri, which is quite prevalent where such foods as polished rice and bolted flour form the main article of diet.

But this water-soluble is present in most ordinary food substances, and particularly in a mixed diet, whereas the sources of the fat-soluble are quite limited, the fat of milk, in the form of milk and butter, being the chief of these.

In support of what has been said, the utterances of some of our leading physiologists and students of nutrition may be quoted.

Dr. H. C. Sherman, Professor of Food Chemistry, Columbia University: "Especially in the feeding of children should milk be used freely, because of its many advantages as a tissue-

building and growth-promoting food. A quart of milk a day for every child is a good rule easy to remember."

United States Food Administration: "Milk is one of the most important food sources the human race possesses. For the proper nourishment of the child it is absolutely indispensable and its use should be kept up in the diet as long as possible. Not only does it contain all the essential food elements in the most available form for ready digestion, but the recent scientific discoveries show it to be especially rich in certain peculiar properties that alone render growth possible. This essential quality makes it also of special value in the sick room. In hospitals it has also been shown that the wounded recover more rapidly when they have milk.

"For the purpose of stimulating growth, and especially in children, butter-fat and other constituents of milk have no substitutes."

Dr. E. V. McCollum, Johns Hopkins University: "I have come to the conclusion, after carefully analyzing the probable effectiveness of the combinations of foods employed in human nutrition, that the efficiency of a people can be predicted with a fair degree of accuracy from a knowledge of the degree to which they consume dairy products. Probably the use of meat and of milk and its products will, in nearly all cases, run more or less nearly parallel, and I venture to assert that it is the milk and butter and cheese, and not the meat which has the good influence in the promotion of the virile qualities of the people.

"Milk is worth much more than its energy value or than its protein content would indicate. It is the great factor of safety in making up the deficiencies of the grains which form and must continue to form the principal source of energy in our diet.

"It seems probable that the only unidentified substance which is physiologically indispensable, which is not sufficiently abundant in the diets employed by the people of the United States and Europe where there are used insufficient amounts of milk, butter, cream, eggs and the leafy vegetables, is the fat-soluble A."

"I wish to again emphasize the fact that there is no way to

supply this dietary factor (fat-soluble A) in the food of children except in the form of milk-fat, and milk is therefore an indispensable food for the young."

Attention should be called to one other point. It has been suggested by some that possibly pasteurization of milk or cream destroys the growth-promoting qualities of the "fat-soluble A" in the fat. Osbourne and Mendel found that passing live steam through milk-fat for two hours did not affect it, and McCollum and Davis found that it was not affected by being heated to the boiling-point of water. This should be satisfactory evidence that pasteurization of milk or cream in no way affects the growth-promoting qualities of the milk-fat.

CHAPTER V

FERMENTS IN MILK

Definition. — The changes which milk undergoes when allowed to stand at a suitable temperature are commonly called fermentations, and the agencies which bring about these changes are called ferments. At one time the ferments were classified under two heads, viz., organized ferments (bacteria, yeasts and molds), and enzymes or unorganized ferments, such as those found in rennet and other fluids in the digestive tracts of animals. This distinction is no longer made, since bacteriologists and physiological chemists have reached the conclusion that the fermentative changes, due to the action of germ life, are caused by enzymes which these micro-organisms produce. However, the enzymes themselves may, from a dairy standpoint, be classified as follows:

(1) The pre-existing enzymes of milk, or those which are formed during milk secretion and consequently are in the milk when it is drawn from the cow. The first of these was discovered by Babcock and Russell of the Wisconsin Station, in 1889, and was named galactase by the discoverers. It is a tryptic ferment. Since then others, such as catalase and peroxidase, have been discovered. It would seem, from investigations made by Russell and Babcock, that the inherent enzymes of milk, which are digesting ferments, are essential to and play an important role in the ripening of the Cheddar type of cheese. They find that it is impossible to produce a typical, normal Cheddar cheese from thoroughly pasteurized milk. According to Storch, the peroxidase has the power of decomposing hydrogen peroxide and setting free "active" oxygen. As this ferment is not destroyed until milk or cream is heated to a high temperature,

it forms the basis for the Storch test for the efficiency of the pasteurization of milk or cream for butter-making. This test is described in the chapter on Pasteurization.

(2) Enzymes developed through the action of germ life—bacteria, yeasts and molds. These are many and varied, and cause most of the changes that take place in milk and its products, such, for example, as the ordinary souring of milk or cream, and the development of flavor and aroma in cream ripening.

(3) Enzymes found in the digestive fluids of animals. All are familiar with the fact that rennet is used in cheese-making. It contains a ferment known as rennin.

It is the second class of ferments or enzymes, the class due to the action of germ life (principally bacteria), which is of the greatest importance in connection with dairying, and with the control of which the dairyman concerns himself most. These ferments are capable of working profound changes, some desirable and some very undesirable.

Size and Shape of Bacteria.—In size, bacteria are the smallest organisms that exist, so far as known. The size varies considerably. Russell¹ gives the average diameter as $\frac{1}{30000}$ of an inch. They are so inconceivably small and light that nine hundred billions of them would only weigh $\frac{1}{28}$ of an ounce.²

Bacteria also vary considerably in shape. They are as a rule classed into three groups: (1) The bacillus or rod-shaped; (2) The coccus or ball-shaped; (3) The spirillum or spiral-shaped (like a corkscrew). Some types of bacteria are classified according to the way in which they adhere to each other. For instance, when two cocci occur together and form a pair, they are called diplococci; when cocci occur in chains, they are called streptococci; when cocci appear in bunches, they are called staphylococci, etc.

FAVORABLE CONDITIONS FOR BACTERIAL GROWTH

Food.—Bacteria, like other plants, need food for their existence. The food passes into the bacterial cell in solution, but many organisms use materials not in solution by producing

¹ Dairy Bacteriology.

² Milk, Its Nature and Composition, by Aikman.

enzymes that dissolve them. Nitrogen, carbon, oxygen, hydrogen and mineral matter are essentials for bacteria. These substances are furnished in abundance in milk from casein, albumen, milk-sugar, and the mineral salts. Butter-fat in milk is said to be of little value as a food for bacteria.

Some organisms, including yeasts and molds, tolerate considerable amounts of acid, while others do not. Most bacteria, however, prefer a neutral or slightly alkaline substance. Darkness is essential to some bacteria, and is preferred by the majority of the different species. Bright sunlight is a very effective

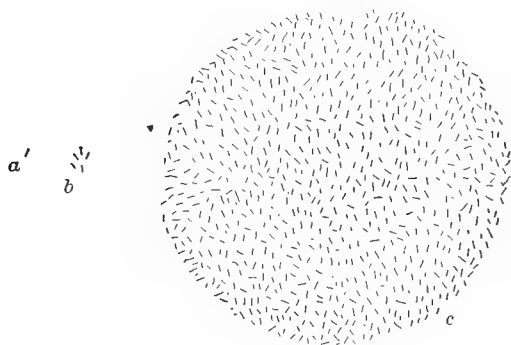

FIG. 7.—*a*, single bacterium; *b*, progeny resulting from the growth of a bacterium during 24 hours in milk at 50° F.; *c*, progeny of a bacterium during 24 hours growth in milk at 70° F. At 50° F. multiplication was 5-fold. At 70° F. the multiplication was 750-fold. (Bul. 26, Storrs, Conn.)

germicide; it is fatal to all species, so far as known. Some germs require air for their growth. These are called aerobic. Others again grow only in the absence of air. These are called anaerobic. Some grow under either or both conditions, and are called facultative.

Temperature.—Favorable temperature is essential to bacterial growth. Temperature is, indeed, the most important means by which the growth and development of bacteria can be controlled. The range of temperature at which bacterial growth is likely to occur may be placed between freezing-point and a little above 110° F. There are, however, exceptions to this

range. Some few species will grow at as high a temperature as 140° F., and *B. bulgaricus* will grow very rapidly at 110° F.

The growth of bacteria at these extreme temperatures is usually very slight. Even at 50° F. the rate of growth is very slow. According to experiments conducted by Dr. Conn, the multiplication of bacteria at 50° F. was 5-fold, while at 70° F. the multiplication was 750-fold. The following table shows the number of bacteria per cubic centimeter in milk kept at different temperatures.¹

No. at Outset	In 12 Hours at 50°	In 12 Hours at 70°	In 50 Hours at 50°	In 50 Hrs. or at Time of Curdling at 70°	No. of Hours before Curdling at 50°	No. of Hours before Curdling at 70°
46,000	39,000	240,500	1,500,000	542,000,000	190	56
47,000	44,800	360,000	127,500	792,000,000	289	36
				36 hours		
50,000	35,000	800,000	160,000	2,560,000,000	172	42
				42 hours		

All bacteria do not have the same optimum growing temperature. Some species develop most rapidly at one temperature, while other species prefer a different temperature for the greatest development. It is on this account that certain temperatures are employed in ripening starters and cream. According to researches by Conn, *Bacterium aerogenes* develops very rapidly in milk at 95° F. This particular species, producing much gas and an unpleasant flavor, sours milk very rapidly. As a rule, milk which has been held at this high temperature contains a preponderance of this undesirable species of bacteria. At 77° F. results are more uncertain; the species of bacteria which will predominate in milk at this temperature depends in large measure upon the number of each kind originally present. According to Conn *Streptococcus lacticus* has the highest relative growth at about 70° F. This particular species produces no gas, and its presence is desirable in cream for butter-making. Milk

¹ Bull, 26 Storrs Sta., Conn.

kept at this temperature will, in most cases, providing it has previously been properly treated, develop a pleasant acid taste, will curdle into a smooth uniform coagulum, and will contain a preponderance of the species of germ mentioned above.

At as low a temperature as 50° F. acid-producing types of bacteria do not develop very well. But Conn maintains that miscellaneous species of bacteria that produce unfavorable results develop at this temperature. While milk does not easily sour at this temperature, it should be remembered that undesirable germs are constantly developing.

As it is practically impossible to exclude all of the bacteria from milk during milking and the handling of the milk, it is very essential that the multiplication of the germs present be checked, or at least retarded; and this can be done by controlling the temperature of the milk. As low temperature is effective in checking the multiplication of the bacteria, the sooner the milk can be cooled after it is drawn, the better it will be likely to keep.

Moisture.—Moisture is one of the essentials for bacterial growth. As milk is composed largely of water, bacteria find in milk a good medium for growth. All the other required food elements are also found in abundance in milk. Damp utensils and rooms are always more conducive to the growth of germs than are utensils and rooms which are thoroughly dried and ventilated. This is well illustrated by a refrigerator. A very damp dark refrigerator is always more conducive to the growth of molds in butter than is a dry refrigerator.

Unfavorable Conditions for Bacterial Growth.—The reverse of the favorable conditions mentioned above would be unfavorable to the growth of bacteria. As it is practically impossible to make conditions unfavorable for the growth of bacteria by taking away food, other means must be used. Extremely high temperatures destroy bacteria. Low temperatures check their growth, but so far as known do not destroy them. Absence of moisture and presence of direct sunlight are conditions which are not conducive to bacterial growth. Certain chemical substances when added to milk, or to the medium in which the bacteria are present, are very unfavorable to their growth. Some of these

chemicals entirely destroy all germ life even when added in very small quantities. These are called disinfectants (formaldehyde, corrosive sublimate, etc.). Other chemicals are more mild in their effect upon germ growth, and merely inhibit or retard the growth of micro-organisms. The chemicals which have this milder effect upon germs are called antiseptics. Boracic and salicylic acids are examples. Practically all disinfectants are

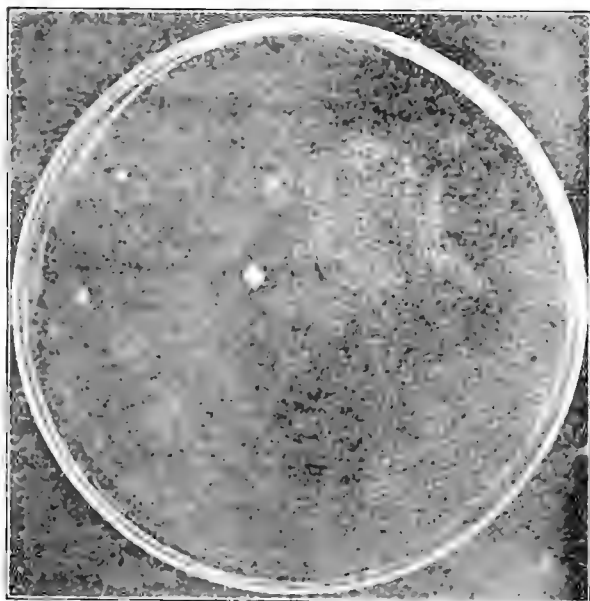

FIG. 8.—Shows a plate exposed in pasture where air must have been very pure and free from germs. (Bul. 87, Nebraska.)

violent poisons, and should not be used in any quantity or in any form in milk or dairy products which are intended for human food. The milder preservatives or the antiseptics, are, as a rule, not so poisonous or injurious to human health. In some countries they are allowed to a small extent. For instance, according to reports, the laws of England permit the use of boracic acid in butter to the extent of 0.5 of 1 per cent. It is, however, safest not to use any of these chemicals, except for preserving samples

for analytical or similar purposes. As low and high temperatures are so effective in producing unfavorable conditions, these should be chiefly employed in controlling the growth of microorganisms in the dairy industry.

Kind of Germs Found in Milk.—The number of species of germs found in milk has not yet been definitely established, due chiefly to the fact that it is in some instances difficult for bacteriologists to differentiate one species from another. The descrip-

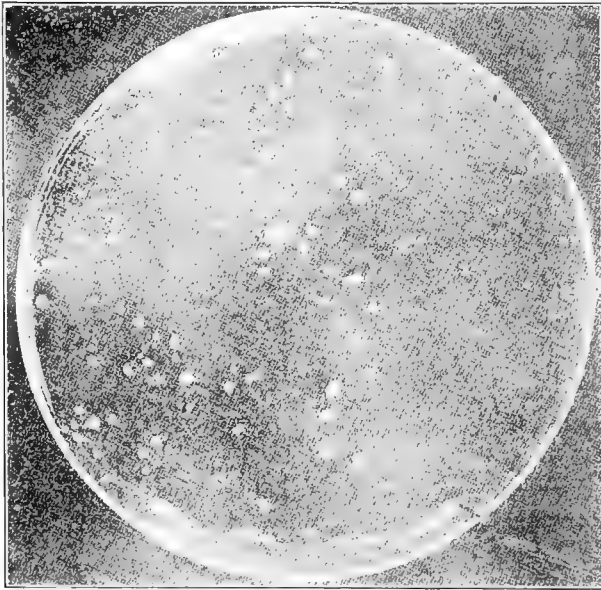

FIG. 9.—Shows a plate exposed one-half minute under a cow's udder treated with a 5 per cent solution of carbolic acid. (Bul. 87, Nebraska.)

tion of one species of bacteria by two different bacteriologists may vary considerably, as the characteristics of the germs depend so much upon the conditions prevailing throughout the classification process. Over 200 different species have been described. It is possible, however, though all of these types may have different morphological and physiological characteristics as described by different bacteriologists, that some two or more of the 200 types may belong to one species.

For this purpose, it is sufficient to classify the bacteria into three groups, viz., (1) those which are harmful to the butter-making industry, (2) those which are beneficial, and (3) those which are indifferent, or produce neither good nor bad results.

From the farmer's or milk-producer's standpoint, none of these bacteria are desirable. Each milk-producer should make it a point to prevent their entrance and suppress their develop-

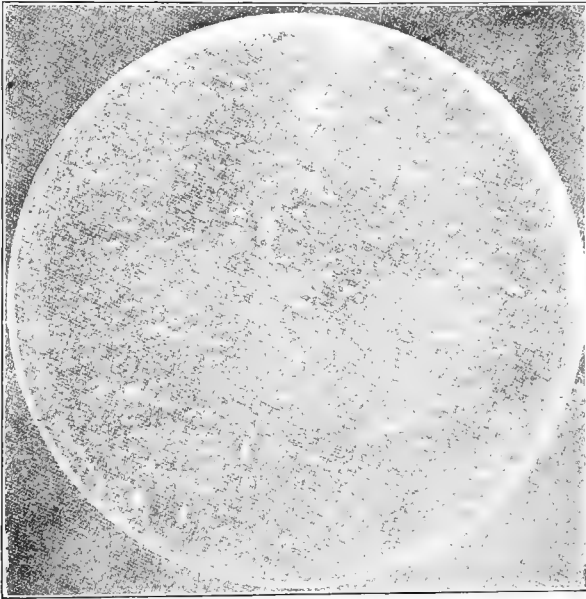

FIG. 10.—Shows plate exposed one-half minute under cow's udder treated by merely brushing with the hand; each little spot represents a colony of some kind of bacteria. (Bul. 87, Nebraska.)

ment in milk and cream to as great an extent as possible. The creamery operator should endeavor to suppress all of the harmful germs, and foster the development of the desirable ones.

The germs which are desirable belong to the acid-producing types, such as *Streptococcus lacticus*, and the associated flavor and aroma-producing types, such as *Streptococcus citrocorus*.

The harmful bacteria include those which produce bitter milk, red milk, blue milk, yellow milk, slimy milk, gas, and

undesirable flavors and aromas. There are a number of species belonging to this group. The pathogenic germs, or disease-producing bacteria, must also be classed with the harmful bacteria. It is not the intention in this work to give an extended discussion of this subject. For such discussion see special works on Dairy Bacteriology.

Number of Bacteria in Milk.—The number of bacteria found in milk varies so much that it is practically impossible to state accurately the average number. The number of germs found varies according to several conditions, such as degree of cleanliness of cows, utensils, and milker; degree of purity of the atmosphere when the cows are milked; the temperature at which the milk is kept and the time it is held. When the milk is being produced under the best practical sanitary conditions, the number of germs need not exceed 10,000 per cubic centimeter. Such results cannot be obtained unless extreme precautions are taken. Milk produced under average farm conditions seldom contains less than 50,000 germs per cubic centimeter shortly after the milking. Milk which is produced under filthy conditions, and which is several hours old, may contain several millions of bacteria per cubic centimeter.

Sources of Bacteria in Milk.—Bacteria are widely distributed in nature. They float in the atmosphere and adhere to particles of dust. Especially is this so in the dusty cow-stable. They are present in all well water to a greater or less extent, and are very abundant in streams and rivers. They are present in the soil to a depth of several feet, the number decreasing with the depth. As these germs are practically present everywhere, the sources of germs in milk may be said to be all around us. The principal sources of germs in milk are, however, unclean dairy utensils, unclean cows, and unclean surroundings. As these germs multiply chiefly by fission, or by one cell dividing into two, it is plain that the number of germs will increase very rapidly under favorable conditions. Under the most favorable conditions it requires approximately twenty minutes for this process of fission to take place.

Some germs develop small bodies within the cell, called

spores. It is not difficult to destroy the sporeless cell by heat, but the spores are very resistant to unfavorable conditions. The spore-bearing bacteria are difficult to kill; boiling for a short time will not destroy them. Hammer is satisfied that they are destroyed by prolonged boiling. Another method is to heat the milk to destroy all the organisms in the vegetative stage, then cool it to a temperature favorable to growth and allow the spores to develop into the vegetative stage, and again apply heat. In this way milk can be rendered entirely sterile. A single heating

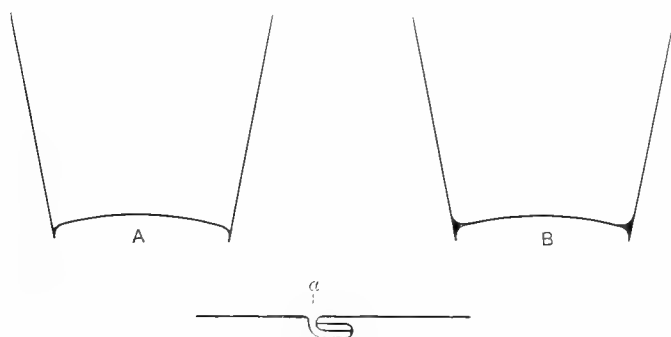

FIG. 11.—The wrong and the right kind of a milk-pail. *A*, the ordinary type of pail showing sharp angle between sides and bottom; *B*, the same properly flushed with solder so as to facilitate thorough cleaning. The lower figure represents a joint as ordinarily made in tinware. The depression *a* affords a place of refuge for bacteria from which they are not readily dislodged. This open joint should be filled completely with solder. (From Bul. 62, Wis.)

under pressure (fifteen minutes at 15 pounds pressure) kills them at once.

It has been demonstrated by several investigators that freshly drawn milk is not a good medium for bacteria to develop in. In fact, several experiments seem to indicate that milk acts as a germicide to certain varieties of bacteria. For instance, the cholera germ is to some extent destroyed in fresh milk, but it is not known to what extent. Organisms producing lactic acid check the multiplications of these pathogenic bacteria. This germicidal property is said to be more or less common to all the animal secretions.

Effect of Thunder-storms on Souring of Milk.—It is a common impression that thunder-storms hasten the souring of milk. This was attributed to the electricity in the air accompanying the storm. Experiments by several investigators have proved that electricity does not have any effect on hastening the fermentative changes of milk. The reason why milk sours more quickly when an electrical storm is approaching is that the air temperature is usually higher then than at any other time. This higher temperature warms the milk and creates more favorable conditions for the rapid multiplication of the germs present in the milk. It is for this reason that milk sours more quickly during or previous to a thunder storm than at any other time.

CHAPTER VI

ABNORMAL MILK

Colostrum Milk.—Colostrum is the milk yielded immediately after calving. As the time of calving approaches, a cow usually diminishes in her milk-producing capacity. Most cows become dry about two months previous to parturition. If they do not naturally stop giving milk, they should be dried up so as to have a seven weeks' rest before calving. When the rest has been given, the cows yield, immediately after calving, milk which has a composition and characteristics different from those of normal milk. If the cow continues to give a copious flow of milk up to the time of calving and is not allowed any rest, the difference in the milk yielded before calving and after calving is comparatively slight.

The composition of colostrum varies considerably during the first three days after calving. According to Engling, as reported by Richmond, the composition is as follows:

	Per Cent
Water.....	71.69
Fat.....	3.37
Albuminoids { Casein	4.83
{ Albumen.....	15.85
Sugar.....	2.48
Ash	1.78

Colostrum greatly changes in composition and appearance as it gradually assumes the characteristics of normal milk. It is at first reddish yellow in color, and has a viscous and slimy consistency. It is a food which the newly born calf should not be deprived of, as it seems to be specially suited for the digestive tract of the young calf.

It will be seen from the above table that the water content of colostrum is less than that of normal milk. The fat content is also a little lower. The most striking characteristics of colostrum, however, are the low content of sugar, and the large amount of albumen. Of the latter substance very little is present in normal milk. The mineral constituents of colostrum also run quite high. Its specific gravity varies from 1.046 to 1.079. When it is boiled, the nitrogenous matter coagulates. The colostrum is not considered suitable for food until about four days after parturition. Whenever it can be boiled without coagulating, it is claimed to be safe to use. At times a cow's udder becomes inflamed after calving. In such cases the abnormal qualities of the cow's milk will extend over a greater period of time than that mentioned above.

Salty Milk.—The average chemical analysis of salty milk as calculated from results obtained by the analysis of such milk from four cows, given by Böggild,¹ is as follows:

Water.....	91.09
Fat.....	2.09
Nitrogenous matter.....	2.90
Sugar.....	3.01
Ash.....	.85

It has an average specific gravity of 1.0244.

Salty milk does not occur very often, but whenever it does occur, it is difficult, and, so far as known, impossible to cure without drying up the cow. Two samples of such milk have recently come within the authors' notice. It had the appearance of normal milk, a foul smell, and a very salty taste. The two samples contained 1.7 per cent and 1.9 per cent of fat respectively. They soured and curdled in a normal way at living-room temperature in about thirty hours. At this stage they were very foul in smell, and unpleasant in taste.

The cows which had produced this milk had both calved about three months previously. It occurred in the month of July, when pastures were quite good. The udders of the cows

¹ Mælkcribruget in Denmark.

were in an apparently normal condition. At first it was thought that some conditions in the pasture caused this abnormal milk. The cows were taken into the barn, and fed on dry food for two weeks, but without any change in the quality of the milk. Gradually they dried up.

The secretion of this salty milk was believed to be due to the long time during which the cows had been yielding milk without any rest. They had been given no rest previous to the last calving. It is also believed that this quality of milk will occur more frequently when the cows are near the close of the lactation period.

While the above two causes are perhaps the most common, they are not the only ones. Salty milk has been obtained in cases where these reasons could not be ascribed. Böggild has found that salty milk has been secreted by cows with abnormal udders. He has also demonstrated that it was the diseased part of the udder from which the salty milk was yielded. The healthy portion of the udder yielded normal milk. It is possible that an obscure, diseased condition of the udder may be the entire cause.

Salty milk is of course undesirable in the dairy or creamery. It is very disagreeable to the taste, and in a fermented stage becomes very foul.

Bloody or Red Milk.—Bloody, or red milk is caused, first, by an abnormal condition of the cow's udder, which may or may not be apparent; and second, a red color may be developed in milk after standing, through the action of bacteria.

The bloody milk, caused by an inflamed udder, often assumes a reddish-yellow appearance, and may, if not examined carefully, be mistaken for colostrum. Bloody milk produced by an inflamed udder may be distinguished by small blood particles, which will settle to the bottom, and can be noticed if the sample is placed in a glass test-tube. In bloody milk caused by bacterial growth the blood does not show at the bottom, but instead, previous to stirring the milk or cream, it appears on the surface in small red dots. The red color which commonly occurs in milk is due chiefly to a species of germ called *Micrococcus prodigiosus*.

Colostrum will show reddish cream on the surface, but no blood-like material will separate out.

Blue Milk.—Blue milk is quite commonly found. Formerly it was thought that this color was due to the condition of the casein in the milk, but since more has been discovered in regard to the effect of germ life upon conditions and properties of milk, it has been proved that blue milk is caused by bacteria ¹ (*Bacillus cyanogenus*). This particular germ produces the blue color in the milk only when the milk has an acid reaction. When sterile milk is inoculated with this particular germ, the blue color is not produced, but by the addition of a little acid, or by inoculating the milk with the bacteria that produce lactic acid, the blue color is produced. This seems to be one of the instances of symbiotic action of bacteria in milk. There are probably other causes, but they are not known. This germ, according to Aikman, is killed by heating the milk to about 176° F. The germ ceases to work as soon as milk is coagulated.

Yellow Milk.—According to Aikman,¹ yellow milk is caused chiefly by one species of bacteria, named *Bacillus synxanthus*. This micro-organism belongs to the group of ferments that act upon the fat of milk. There are different shades of yellow produced in milk, caused by different species of bacteria, but the above-mentioned one is considered to be the principal cause. Some produce a brilliant yellow color, while other species first curdle the casein, and then digest or dissolve it into a yellow or amber-colored liquid.

Ropy Milk.—Slimy or ropy milk is not common, but is sometimes encountered by milk-dealers and is caused by certain micro-organisms. Aikman mentions the fact that no less than eighteen different and distinct organisms have been identified as associated with this slimy fermentation. Most of the investigators agree that two organisms are chiefly responsible for the slimy condition. One of these is *Bacillus lactis viscosus*,² which grows best in the presence of air and neither forms acid nor thrives in an acid medium. This germ has been found to be frequently

¹ C. M. Aikman, in "Milk, Its Nature and Composition."

² Adametz, Landw. Jhr., 1891, p. 185.

present in surface waters. Bouska broke off a sliver from a water tank which, when put into milk, inoculated it with an organism that produced ropiness. The very fact that milk dealers in cities are occasionally troubled with this sliminess in milk indicates that precautions are essential in order to avoid the presence of this ferment. The germ, when it once gains entrance to a milk establishment, is very difficult to eradicate. In order to overcome the trouble it may be necessary to cover the whole inside of the milk-store, and all of the vessels used for handling the milk, with sour coagulated milk. The lactic acid germs present in this milk gain ascendancy over the germs causing sliminess and in that way the trouble may be eradicated.

*Streptococcus hollandicus*¹ is another species which produces sliminess in milk. It differs from the ferment mentioned above in that it grows in the absence of air and produces acid. It is used in Holland, in the preparation of the slimy whey (lange Wei) starter which is added to milk used in the manufacture of Edam cheese, just as we use a pure culture lactic acid starter in connection with Cheddar cheese-making.

Sometimes milk is slimy when drawn from the cow—most frequently when there is inflammation of the udder. There are, in such cases, no bacteria present in the milk as the cause of the ropy or slimy condition. We quote Russell and Hastings: “The direct cause of the abnormal condition in milk is the presence of fibrin and white corpuscles from the blood, which form masses of slimy material; in such cases the trouble does not increase in intensity with age, nor can it be propagated by transference to another sample of fresh milk.”

Bitter Milk.—This is one of the most common kinds of abnormal milk, and like some of the others, may have more than one cause. It may be due to some undesirable food that the cow has eaten, or to the development of certain germs in the milk. If caused by the food eaten by the cow, the bitter taste is recognizable immediately after the milk has been drawn. If it develops on letting the milk stand, it is caused by bacterial growth.

Several germs have been found to be associated with the pro-

¹ Milch Zeit., 1889, p. 982.

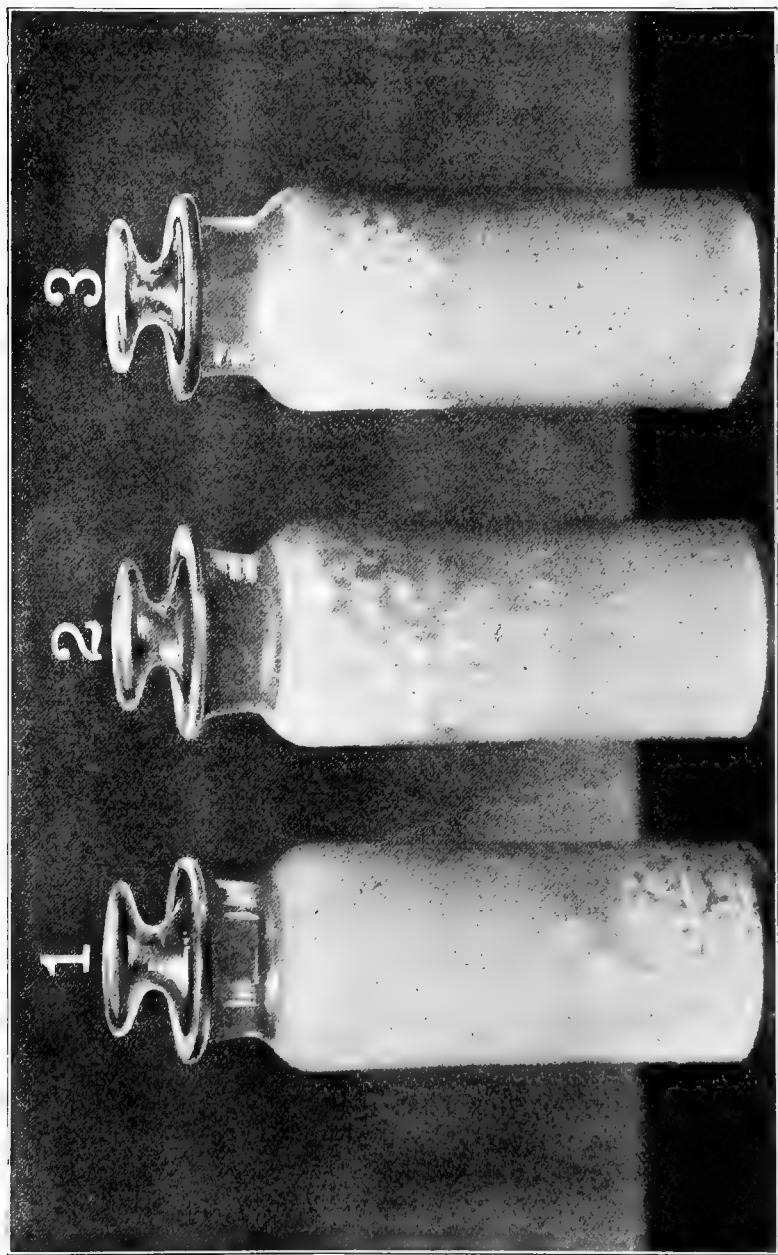

FIG. 12.—Showing effect of gassy fermentation in milk. The floating curd in 2 and 3 shows the presence of gas-producing ferments.

duction of this bitter flavor in milk. Conn has described a micrococcus which produces a bitter flavor, and Weigmann has described a bacillus which produces a similar effect. Nearly all of the investigators agree that the germs causing the bitter flavors in milk belong to the group which acts upon the casein. The bitter flavor is most commonly found in milk that has been heated and then cooled to a low temperature. The heat destroys the bacteria that produce lactic acid, but does not kill those that produce the bitter flavor, owing to the fact that they are spore-producing.

The germs that produce a bitter flavor do not develop in milk that is partly soured, because an acid reaction is unfavorable to their growth.

It was formerly thought that the organisms that cause the bitter flavor in milk produced butyric acid. This theory, however, has been largely overthrown, as it has been found that these germs are chiefly of the kind which peptonize the casein and produce gas.

Milk from Cows which Have Been in Milk for a Long Period.—The difference in the composition of the fat yielded by cows in different stages of the lactation period does not seem to affect the quality of the milk to a noticeable extent. If the cows have been giving milk an unusually long time, the milk may become abnormal.

The impurities in the small amount of milk yielded by a cow almost dried up are quite apparent, and the causes of the presence of these impurities are readily understood. The small amount of milk drawn from such a cow would contain a proportionately larger amount of dirt and germs than would a larger amount of milk drawn from a cow yielding more milk, providing the cleanliness of the udder and manner of milking were the same. Cows giving a good quantity of milk always seem to have a cleaner udder. This has been laid to the more vigorous circulation of the blood in the udder of the cow that yields a larger portion of milk.

When cows calve once a year, and have a rest of about seven weeks previous to parturition, if proper precautions are taken

concerning cleanliness, they seldom yield milk from which a first-class quality of butter cannot be produced. In practice calving does not always occur at regular intervals. Several instances have come within the authors' notice where cows have been in milk for two years or more without coming in fresh. Such a condition happens quite frequently on small farms, where the cows kept are so few that it is deemed impracticable to keep a bull. As a consequence cows are not served at the proper time, and great irregularities in calving are introduced.

At times it also happens that cows become barren. In such a case they are usually milked as long as they will produce even a very small quantity of milk. Milk produced under such conditions is likely to become abnormal in character. It may remain normal with a slight increase in the fat-content. The abnormal milk, so often complained of, is usually the result of similar circumstances. It is a common belief that milk yielded by such animals always contains a high fat-content, but it may contain very little fat, and may be salty. It may also appear normal, and the cream when separated appear viscous and dead. Böggild states that at the creamery the milk from one barren cow has more than once produced difficult churning.

Milk from Spayed Cows.—H. Lennat has given this kind of milk considerable study. He finds that milk from spayed cows may vary in quality to the same extent as milk from normal cows. The solids of milk, as a rule, increase as the spayed cow advances in the milk-giving period. This is especially noticeable in the fat, sugar, and casein. Such milk is considered to be of extra good quality, and is recommended as being especially suitable for infant-feeding.

Milk from Sick Cows.—Too much cannot be said against the use of milk from sick cows. As soon as the cows decline in health, the quantity is noticeably decreased, and the quality is usually abnormal. The kind of milk yielded varies with different cows and different diseases, but it is interesting to note from the study of this subject, by several men, that the milk-secreting glands are quickly affected by disease and are unable to perform their proper functions. Even a slight derangement of the

digestive organs may have a marked influence upon the flavor of the milk and butter. When cows do not clean well after calving, the milk secreted by them always has an undesirable taste. During the time of sexual excitement of the cow, milk is usually decreased in quantity, and in a great many instances possesses a very disagreeable flavor.

When a cow's udder is inflamed, the milk usually assumes an abnormal condition. It usually contains large, white slimy lumps. According to Bang,¹ this condition is caused by a small round bacterium, and is contagious. When this germ is inoculated into the udder, the cow becomes feverish and the milk slimy.

When cows become infected with tuberculosis to such an extent that the udder shows lesions and nodules, the composition and appearance of the milk is altered considerably. Milk from such cows contains tubercle germs, appears yellowish-brown in color, and has an alkaline reaction. The composition of such milk has been studied in Denmark and reported by Bøggild to be as follows:

Water.....	88.57
Fat.....	3.55
Albuminoids.....	5.69
Sugar.....	1.25
Ash.....	.94

These results represent the average of four samples taken from the diseased part of the udder. It will be seen that the greatest variation from normal milk consists in the small amount of sugar it contains and the high per cent of ash and nitrogenous matter.

¹ Maelkeribruget i Denmark, by Bøggild.

CHAPTER VII

VARIATION OF FAT IN MILK AND CREAM

As the variations in the per cent of fat in milk and cream are due to such widely different causes, it has been found expedient to divide this chapter into two parts.

PART I

VARIATION OF FAT IN MILK

The percentage of fat in normal milk varies a great deal more than that of any of the other constituents. Dr. Richmond reports that the fat of milk may go as low as 1.04 per cent and as high as 12.52 per cent. Such extreme variations are, of course, abnormal. The fat-content seldom falls below $2\frac{1}{2}$ per cent or rises above 7 per cent. The fat-content of milk from a whole herd of cows varies only within comparatively narrow limits. The following are the chief factors which cause the fat-content of milk to vary:

- (1) Individuality of cows.
- (2) Breed of cows.
- (3) Time between milkings.
- (4) Manner of milking.
- (5) Whether the milk is fore or after milk.
- (6) Age of cow.
- (7) Advance in lactation.
- (8) Feed of cows.
- (9) Environment.
- (10) Condition of cow.

1. Individuality.—Whether a cow will produce milk with a high or low fat-content depends upon something that is inherent in the individual animal. Cows in the same herd, under the same

conditions as to care, feeding, etc., will produce milk that differs widely in this respect. The secretory organs of the mammary gland are the large controlling factor, and these we cannot change. Even in the same breed we find animals that differ very widely, as the table below, compiled from complete records by Eckles, will indicate. These are average yearly tests for the highest and lowest testing animals in each breed.

Breed	Number of Cows	Highest Per Cent of Fat	Lowest Per Cent of Fat
Jersey.....	76	7.00	4.47
Shorthorn.....	25	4.31	3.59
Holstein.....	40	3.81	2.60

2. Breed of Cows.—The different breeds of dairy cattle have their distinctive “breed characteristics,” and the most important of these are the quantity of milk they produce and its richness in butter-fat.

The Channel Island breeds—Jersey and Guernsey—are noted for the high fat-content of their milk; the milking strain of Shorthorns and the Ayrshire breed produce a milk of medium richness, while the Holstein produces a milk somewhat lower in fat content. As to quantity of milk produced the order reverses itself.

For all the breeds, excepting the Milking Shorthorn, the table which follows, giving the *average* production and composition of the milk of the different breeds, is based upon Bulletin 156 of the Bureau of Animal Husbandry of the U. S. Department of Agriculture, which summarizes and digests the published reports of all the American experiment stations upon this subject.

3. Time between Milkings.—Where cows are milked twice a day—the common practice in the United States and Canada—the difference in the per cent of fat in the two milkings is quite marked, if the intervals are very unequal. On the other hand, if the intervals are equal, or nearly so, the difference is not great.

AVERAGE COMPOSITION OF THE MILK OF DIFFERENT BREEDS

Breed	Yearly Milk Yield, Pounds	Per Cent of Fat	Pounds of Fat	Per Cent of Total Solids
Jersey.....	5508	5.14	283	14.9
Guernsey.....	5509	4.98	274	14.2
Ayrshire.....	6533	3.85	252	12.9
Holstein.....	8690	3.45	300	12.3
Milking Shorthorn.....	5500	4.00	220	13.0

Experiments made by Ingle bring these points out quite clearly. Five cows were milked at 6 A.M. and 3 P.M. during a period of three weeks. The average fat-content of the evening's milk was 4.26 per cent, while that of the morning's milk was 2.8 per cent. Following this, for four weeks, the cows were milked at 5.30 A.M. and 5 P.M. and the average evening and morning tests were 3.80 per cent and 3.18 per cent respectively. Even here there was a difference of an hour in the length of the two intervals, which would account, largely, for the difference in test. It is claimed, however, that with equal intervals the evening's milk will test slightly higher than the morning's milk. This is attributed to greater activity of the fat-secreting cells when the cows themselves are more active.

Milking three times a day, as is the custom in Denmark, increases, to some extent, both the quantity of milk produced and the per cent of fat in it. But the increase is not sufficiently marked to induce the average farmer in America to adopt this practice, except in the case of a cow which is an exceptionally large producer.

4. Manner of Milking.—Milking should be done in such a manner as to induce the cow to be sympathetic toward the milker. Hand milking should be performed quickly, but not roughly or in a way that will excite the animal or create discomfort. The hand should close regularly and quickly from above downward, in such a way as to extract the milk quickly and efficiently. The finger ends should not press into the teats

uncomfortably, nor should the nails come into contact with the teat to the extent of irritating it. As will be seen in dealing with fore and after milk, the milking must be done thoroughly since the strippings are very rich in fat content.

There is a marked difference between milkers. On this point we quote from Decker. "By looking over the milking records of the University of Wisconsin, it was possible to pick out the cows milked by a certain milker, for he could (or rather did)

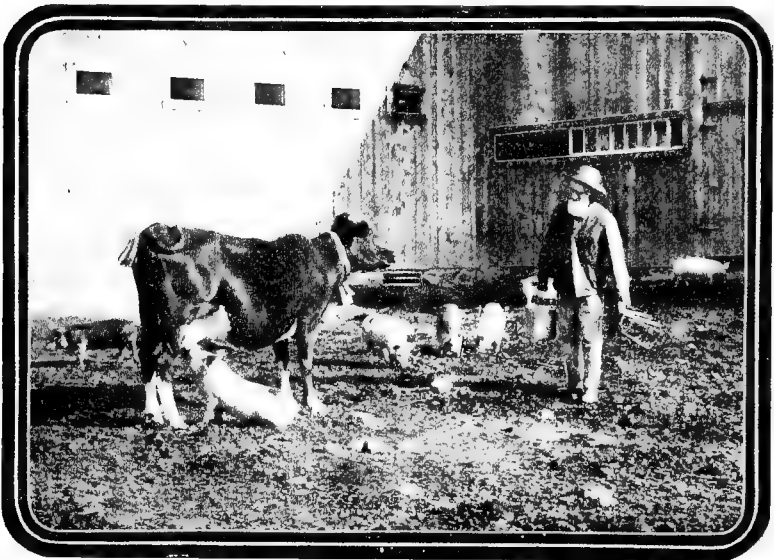

FIG. 13.—The wrong way to milk cows. (From Glucose Sugar Refining Catalogue.)

invariably get more and richer milk from the same cows than when the cows were milked by other men."

5. Fore and After Milk.—The first milk drawn from a cow is very low in fat content, containing just a few tenths of a per cent of fat; while the last, the strippings, will test very high, often up to 8 to 10 per cent.

Van Slyke of the New York Station analyzed the different portions of the milk of a Guernsey cow, with the following results:

	Pounds of Milk	Per Cent of Fat
First portion.....	3.2	0.76
Second portion.....	4.1	2.60
Third portion.....	4.6	5.35
Fourth portion.....	5.8	9.80

The practical lesson to be drawn from this is that milking should be done efficiently and completely.

6. Age of Cow.—As already pointed out, the richness of a cow's milk is very largely determined by heredity. She will not produce rich milk during one lactation period and poor milk during another. However, age has its influence. Normally there is a marked increase, from year to year, in the quantity of milk given, with a tendency to a slight increase in the fat-content, until a cow reaches maturity. Then, in the ordinary course of events, we may look for a gradual decline. The following is quoted from Eckles, whose investigations were both extensive and thorough: "On the average, a well-grown two-year-old may be expected to produce 70 per cent, a three-year old 80 per cent and a four-year old 90 per cent of the milk and fat that she will produce when mature." "The average fat-content remains practically constant from year to year, except that after the cow is eight or nine years old the percentage of fat always declines slowly and gradually with advancing years."

7. Advance in Lactation.—This is a factor that materially influences both the quantity of milk produced and its fat-content. When a cow freshens she will probably, if in reasonably good condition, produce milk with a slightly higher per cent of fat in it than there will be a little later. With this exception the quantity of milk produced and the per cent of fat in it usually remain fairly constant during the first three or four months, after which there is a gradual decline in the quantity of milk produced and a steady increase in its richness. But cows differ very widely in the rate of increase in the fat-content of their milk as they advance in their lactation period. The following table gives the

records of two cows in the same Canadian herd, both of which freshened in the spring and at practically the same time—also the average for fourteen cows at the Geneva Station:

Month No.	Cow No. 1		Cow No. 2		Geneva (14 cows)	
	Pounds of Milk	Per Cent of Fat	Pounds of Milk	Per Cent of Fat	Pounds of Milk	Per Cent of Fat
1	546	3.4	614	3.3	753	4.02
2	618	3.4	704	3.2	780	3.74
3	622	3.5	714	3.7	714	3.71
4	723	3.5	721	3.8	636	3.84
5	714	3.7	693	4.1	588	3.87
6	636	3.9	627	4.4	594	3.90
7	601	4.0	591	4.6	570	3.94
8	540	4.1	502	5.1	480	3.89
9	427	4.1	461	5.3	375	3.92
10	214	4.2	47	7.6	282	4.16
11	168	4.58

8. Feed of Cows.—There was at one time a very general belief, which still has its advocates, that the per cent of fat in milk varies with the nature of the food the cow receives; but many investigations made both in America and in Europe have shown that, practically speaking, the richness of a cow's milk is not influenced by her food. A narrow ration, one made up quite largely of concentrates rich in protein, will stimulate the milk flow, a fact which is well known and made use of by those experienced in the fitting and feeding of cows for high official records; but it does not increase the per cent of fat in the milk.

Observations by the Copenhagen (Denmark) Station over a period of ten years, and including about 2000 cows, led the observers to conclude that foods high in protein content may possibly raise the fat-content of the milk to the extent of 0.1 per cent—a very slight increase if actually an increase at all. Lindsay of the Massachusetts Station found that a ration with a

large excess of protein stimulated the milk flow to the extent of 15 per cent, but he concluded that the per cent of fat in the milk is not influenced by the food a cow receives.

The addition of such abnormal foods as tallow, lard, palm and oleo oils to a cow's ration, or such a radical change of food and environment as from stable to pasture conditions, may cause a temporary change in the per cent of fat in a cow's milk, but the change is only temporary.

9. Environment.—Such unfavorable conditions as exposure to inclement weather, sudden changes in temperature, and poorly ventilated barns will cause a decrease in the milk flow. Experienced cheese and butter-makers have noted a very serious falling off in the output of their factories within a comparatively short time, when the cows were exposed to low temperatures and cold storms. Under continued exposure to unfavorable environment there may be, at first, a temporary increase in the per cent of fat in the milk.

Reasonable exercise, under suitable weather conditions, is favorable to both health and a large production, but excess of exercise is not desirable. Where cows are confined to the stable, without exercise, the production may be quite satisfactory, but these conditions are detrimental to the health of the animal and, in the authors' opinion, are contributory to the spread of tuberculosis in a herd. In Denmark it is the common practice to keep the cows closely confined, without exercise, during the winter months, and tuberculosis is very prevalent amongst the herds of that country.

To secure the best results we must study the comfort of the animal, and under the head of comfort we include favorable temperature, clean healthful surroundings and the avoidance of rough treatment and excitement.

10. Condition of Cow.—If a cow be in a high state of flesh when she freshens, her milk will test much higher during the first few weeks than it otherwise would. Investigations made by Professor Eckles of Minnesota University bring this point out very clearly. We submit the following table based upon work done by him:

Time after Calving	No. 207	No. 217	No. 300
Days	Per Cent	Per Cent	Per Cent
2	5.8	4.4	4.5
5	4.8	4.2	4.2
10	3.9	3.5	4.1
15	3.2	3.7	3.9
20	2.5	3.4	3.6
Months			
3	2.6	3.0	3.6
6	2.4	3.5	4.0
9	3.0	3.4	
12	3.3	4.1	
Aver. for Year	2.8	3.4	3.55

Compare the first part of this table with that of the preceding table in connection with "Advance in Lactation Period."

On the other hand, Eckles found that when a cow begins to put on flesh there is the very opposite tendency, namely, for the per cent of fat in her milk to decline.

PART II

VARIATION OF FAT IN CREAM

The percentage of fat in cream delivered to creameries or for city trade varies considerably from day to day, and a great deal of dissension arises from the fact that the producer does not always understand all the factors that are responsible for this wide variation.

Extensive work has been done by Professor O. F. Hunziker, Purdue University, and similar work has been carried on at the Danish Experiment Station at Copenhagen. The work done at Purdue and other experiment stations plainly and conclusively shows that there are a great variety of factors and conditions which control the richness of cream. These factors influence the richness of the cream before it leaves the farm and cannot be

controlled by the creameryman, who receives the cream after it has been separated. It is physically impossible to produce cream of exactly the same richness from different skimmings under the gravity method of creaming. It is impossible to so operate the spoon, ladle or skimmer as to remove the same amount of skim-milk with the cream each time. Where the skim-milk is drawn from the bottom of the can it is equally impossible to so gage the operation as to leave cream of the same richness in the can at each skimming. Gravity cream, or cream obtained by gravity skimming, is sure to vary in richness, and it is not difficult for the producer to realize the causes of variations under this method of creaming. It is more difficult, however, to convince him that the richness of the cream will vary where the small centrifugal or farm separator is used. The separator is one of the most perfect pieces of farm machinery in use, and is accordingly expected to do nearly perfect work. It is only reasonable that the user of the small centrifugal machine will expect to produce a uniform quality of cream; hence, when he sells this cream and finds that the test is not the same as it was on the previous day he suspects that something is wrong. The small farm separator does produce the same richness of cream from different skimmings, provided that it is adjusted properly, that it is operated in strict accordance with directions which accompany it, and that the richness, condition and temperature of the milk, and the proportion of water or skim-milk used in flushing the bowl to the amount of milk separated, are the same.

The following are the chief factors which influence the per cent of fat in cream:

- (1) Cream screw adjustment.
- (2) Richness of milk.
- (3) Rate of inflow.
- (4) Speed of machine.
- (3) Temperature of milk.
- (6) Amount of water or skim-milk used to flush the bowl.

1. The Cream Screw.—The richness of the cream obtained from any farm separator is primarily determined and regulated

by the cream screw. The centrifugal separator has two main outlets, namely, the skim-milk outlet located near the periphery or outer wall of the bowl, and the cream outlet, located near the center of the bowl.

When the milk enters the revolving bowl it is separated into two layers, the skim-milk and the cream. The skim-milk, being heaviest, is thrown against the walls of the bowl where it escapes through the skim-milk outlet. The cream is drawn toward the center of the bowl, where it rises and is discharged through the cream screw or cream outlet. The cream screw is a small threaded bolt with a very minute opening. This bolt can be turned so as to move the opening nearer or farther from the center of the bowl. When turned toward the center it delivers richer cream, because a smaller proportion of the milk is taken as cream. When turned out from the center it delivers thinner cream, because a larger proportion of the milk is taken as cream.

2. Effect of Richness of Milk on Richness of Cream.—The richer the milk, the richer will be the cream. With the cream screw set to deliver a certain and definite richness of cream and all other conditions normal, the separator will deliver a definite ratio of skim-milk and cream. This ratio varies according to the way the cream screw is set. Under average conditions it may be about 85 to 15; that is, for each 100 pounds of milk separated the separator delivers 85 pounds of skim-milk and 15 pounds of cream. If all conditions are the same, this ratio of skim-milk to cream remains constant. Changes in the richness of the milk cannot alter the proportion of skim-milk to cream delivered. No matter how rich or how poor the milk, each 100 pounds of milk will yield 85 pounds of skim-milk and 15 pounds of cream.

But because practically all of the fat goes into the cream, the cream will contain more fat from the separation of rich milk than from that of thin milk. This fact is graphically illustrated in Fig. 14.

The illustration (Fig. 14) conclusively shows that, all other conditions being the same, 3 per cent milk produces 20 per cent cream, 4.5 per cent milk produces 30 per cent cream, and 6 per

cent milk produces 40 per cent cream. Changes in the richness of milk cause changes in the richness of the cream. Any condi-

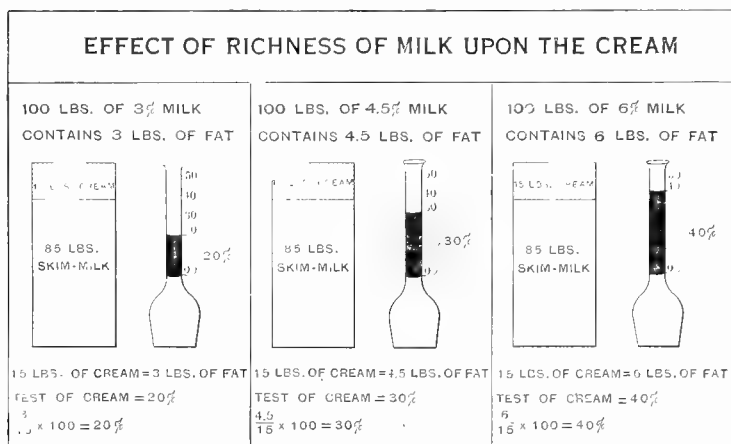

FIG. 14.

tion, therefore, that affects the richness of the milk will also influence the richness and the test of the cream.

Conditions that May Cause Changes in the Richness of the Milk.—During the early summer months the milk is usually comparatively low in butter-fat. This is caused by such factors as the freshening of the cows, change from dry feed to succulent pasture and a natural and inherent tendency of the cows toward a decrease in the richness of their milk in early summer. Toward fall and early winter the opposite is the case. The advanced state of the period of lactation and the change from succulent to dry feed cause the milk to become richer in fat. It is obvious, therefore, that in the fall and winter the cream test tends to be higher than in spring and early summer.

Again, it frequently happens that even in winter there is a sudden drop in the cream test. This may be due to the fact that some of the cows yielding rich milk dry up or that some cows come in fresh or a new animal may be brought into the herd.

The seasonal variations in the richness of the cream may be reduced by turning out the cream screw a trifle in the fall and by turning it in during the spring of the year.

3. **Effect of Rate of Inflow on Richness of Cream.**—The greater the amount of milk passing through the separator of a definite capacity per hour, the thinner will be the cream.

The skim-milk outlet of the bowl is constant. It can discharge so much skim-milk and no more. It offers the first available exit for the milk in the bowl. Since it is located at the periphery of the bowl toward which the skim-milk is forced, it discharges skim-milk.

All the milk that flows into the bowl in excess of what the skim-milk outlet can discharge, leaves the separator through the

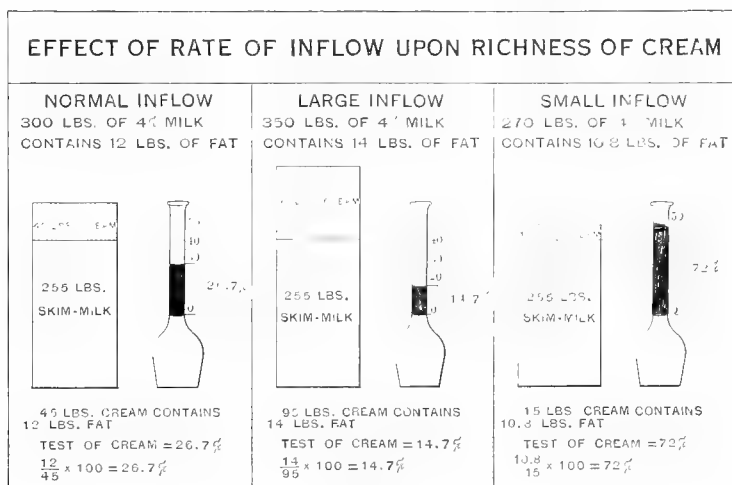

FIG. 15.

cream outlet or the cream screw. The cream outlet, being located near the center of the bowl where the cream gathers, delivers cream.

The cream outlet then serves as the overflow. The greater the amount of milk running into the bowl in excess of the capacity of the skim-milk outlet, the greater is the overflow, the more milk will leave the bowl through the cream outlet and the thinner will be the cream. If the separator is so adjusted that, under normal conditions, each 100 pounds of milk produces 85 pounds of skim-milk and 15 pounds of cream, a 300-pound capacity machine

will deliver $85 \times 300 \div 100$ or 255 pounds of skim-milk and the remainder, the overflow, will be cream. In this case the amount of cream discharged will be 45 pounds ($300 - 255 = 45$). If the separator is forced beyond its capacity, that is if more than 300 pounds of milk are run into the machine, the skim-milk discharged remains the same and the cream discharged receives the extra milk. Running 350 pounds of milk into the machine, for example, causes the separator to yield 255 pounds of skim-milk and 95 pounds ($350 - 255 = 95$) of cream. If the milk inflow is reduced below the capacity of the cream, say to 270 pounds, the skim-milk discharged remains the same (255 pounds) and the cream discharged is 15 pounds ($270 - 255 = 15$). The effect of these variations in the rate of inflow on the richness of the cream is shown in Fig. 15.

The above diagram shows that almost any richness of cream may be obtained from the same milk and the same separator according to the amount of milk that flows into the bowl per hour. A normal inflow produced 26.7 per cent cream, a large inflow produced 14.7 per cent cream and a small inflow produced 72 per cent cream.

Even the fullness of the pan or tank from which the milk runs into the bowl affects the richness of the cream. The fuller the tank the more rapidly will the milk flow into the bowl owing to a few inches of additional pressure. If the tank is kept filled to the brim the cream will be thinner than when the tank remains only one-third full.

Every separator is equipped with a simple device called the "Float" to regulate the inflow. The float fits into the receiving cup of the bowl. When too much milk flows into the bowl the float rises and partly shuts off the outlet of the milk supply tank. When too little milk runs into the bowl the float recedes and the supply tank delivers more milk.

The simplicity of the float has had a tendency to belittle its value in the mind of the average dairyman, with the result that on many farms it is not used and has been discarded. Bearing in mind the marked effect of the rate of inflow on the richness of the cream it seems inconsistent to accuse the creamery of inac-

curate testing when the separator float is a conspicuous part of the scrap pile on the farm.

4. **Effect of Speed of Machine on Richness of Cream.**—The speed of the revolving bowl produces the force—centrifugal force which drives the skim-milk out of the bowl. The greater the speed, the greater the centrifugal force and the more rapidly the skim-milk leaves the bowl. An increase in the speed, therefore, forces more skim-milk through the skim-milk outlet. This means less milk for the cream outlet and consequently

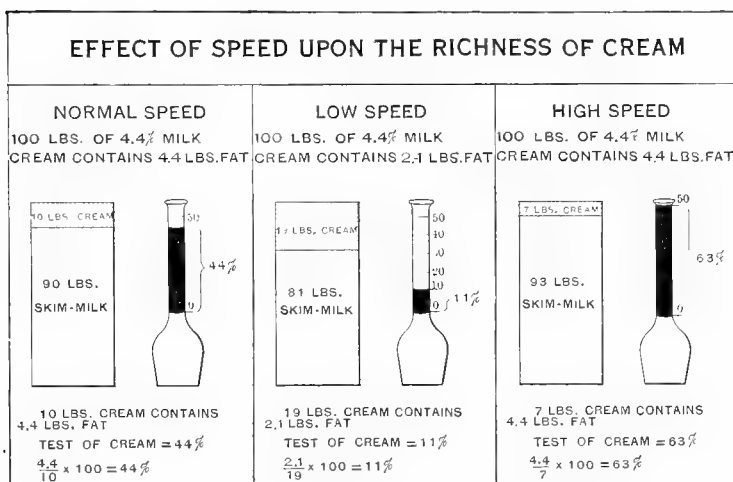

FIG. 16.

richer cream. A decrease in the speed forces less skim-milk through the skim-milk outlet, more milk has to be discharged through the cream outlet and the cream, therefore, is thinner.

These facts were established experimentally. A separator was so adjusted that, when run at normal speed (60 turns of crank per minute), it delivered 90 pounds of skim-milk and 10 pounds of cream. When the speed was lowered to 25 turns of the crank per minute, the skim-milk outlet discharged only 81 pounds of skim-milk, increasing the amount of cream delivered to 19 pounds. When the speed was raised to 75 revolutions per minute, the skim-milk discharge increased to 93 pounds, reducing

the amount of cream to 7 pounds. The effect of these variations of speed on the richness of the cream are shown in Fig. 16.

Fig. 16 demonstrates conclusively that high speed yields rich cream and low speed yields thin cream. At normal speed, the cream tested 44 per cent fat, at low speed 11 per cent fat, and at high speed 63 per cent fat. The very low test of cream from a low speed separation is, in part, due to the fact that a large amount of fat (about one-half of the fat of the milk) is lost in the skim-milk.

How to Run the Separator at the Right Speed.—The proper speed is indicated on the crank of the machine. It varies from about 40 to 60 turns of the crank per minute, according to the make of the separator. If a separator is to yield cream of uniform richness, it must be given the same speed at each skimming. This is possible only if the operator times himself frequently, counting the revolutions of the crank with watch in hand, or by the use of a patent speed indicator. The absence of this precaution renders the work unreliable. The general tendency on the part of the operator is to overestimate the amount of work he puts into the machine; the machine is run at too low a speed. Even the same operator may vary the speed very considerably at different times, depending on his frame of mind and physical condition. Again, where different persons operate the machine, there can be but little uniformity of speed, unless each person makes an effort frequently to count the crank revolutions by the watch. The use of a gasoline engine or some constant power will tend to give a more uniform cream than when the machine is operated by hand.

5. Effect of Temperature on Richness of Cream.—The higher the temperature the thinner the cream. The temperature influences the rate of inflow. The warmer the milk the more rapidly will it run from the supply tank into the bowl. Since the capacity of the skim-milk outlet is fixed, the increased inflow of the milk is discharged through the cream outlet, producing a thinner cream. Experimental results showed that when the separator was so adjusted as to yield 15 pounds of cream and 85 pounds of skim-milk from every 100 pounds of milk separated

at 90° F., a drop in the temperature to 50° F., caused the amount of cream delivered to decrease to 5.5 pounds and the skim-milk to increase to 94.5 pounds. These results are graphically illustrated in Fig. 17.

The results expressed in Fig. 17 show that when the temperature of the milk is decreased below normal, the richness of the cream increases. At 90° F., the cream contained 26 per cent fat. At 50° F. it contained 40 per cent fat. The increase in the test of the cream from the cold milk would be still greater, if it were

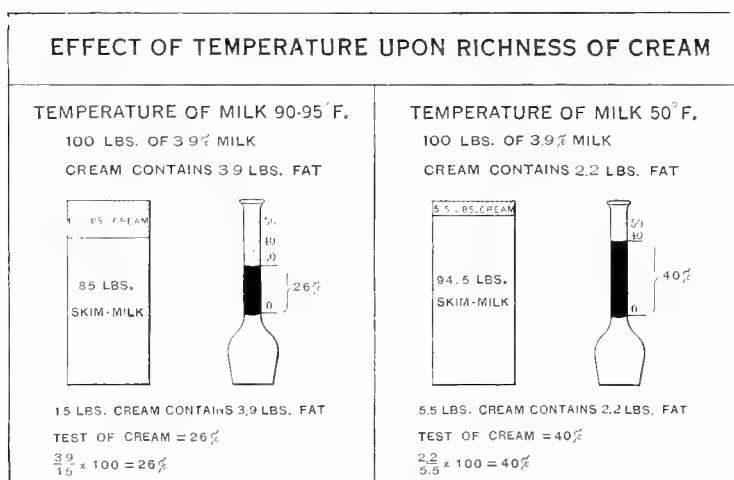

FIG. 17.

not for the fact that at that temperature a large amount of fat is lost in the skim-milk.

The Proper Temperature for Separation.—The best practical temperature at which to separate the milk on the farm is about 90° F. The milk is never in better condition for separation than immediately after it is drawn. It then has a temperature of about 90° F. to 95° F. If the milk is allowed to cool to a much lower temperature, as is the case in the winter, when the separator is operated only once per day, or once in several days, it should be warmed up to about 90° F. before it is run through the separator; otherwise there is bound to be a considerable variation in the cream test and also an increased loss of fat in the skim-milk.

6. Effect of Amount of Water or Skim-milk Used to Flush the Bowl.—The more water or skim-milk used to flush the bowl, the thinner will be the cream.

At the conclusion of the separation there remains in the bowl and in the cream-discharging pan a considerable quantity of cream. In order to save this cream it is necessary to flush the bowl with water or with skim-milk. If enough water or skim-milk is used the cream remaining in the separator is flushed out and discharged into the cream can.

The extent to which the cream test is lowered by flushing the bowl will depend on the amount of water or skim-milk used, the manner in which it is added and the amount of milk separated.

If just enough water or skim-milk is used to thoroughly rinse out the bowl and the pan or tank, the richness of the cream is not materially changed. An excess of water or skim-milk may cause a considerable decrease in the richness of the cream.

If the water or the skim-milk is poured into the supply tank and is allowed to run into the machine gradually, most of it will escape through the skim-milk outlet and the richness of the cream will be changed but very little. If the water or skim-milk is poured directly into the receiving cup of the bowl, with the float discarded, it will run into the bowl much more rapidly and more of it will get into the cream.

The smaller the amount of milk used for the separation, the more the cream is thinned down by the flushing.

Experimental data show that the cream test may be lowered from 1 to 10 per cent according to the amount and conditions of the flushing. Enough water or skim-milk has been used when the cream discharge begins to appear watery. Hot water or warm milk will drive the cream out of the bowl more quickly and may produce a higher testing cream.

The Proper Richness of the Cream.—Too thin cream is not satisfactory because it leaves but a small amount of skim-milk for the use of the dairy farmer, it increases the cost of transportation, it sours and spoils more rapidly, it prohibits the use of a reasonable amount of starter for ripening at the creamery, it does not churn out exhaustively, and yields an excessive amount

of buttermilk, augmenting the loss of fat and therefore reducing the churn yield.

Too thick cream is undesirable because it may cause the separator to clog, it increases the loss in handling, it is difficult to properly sample and interferes with the accuracy of the test.

The most satisfactory cream for butter-making is that which tests about 30 to 40 per cent fat. It is desirable to produce somewhat richer cream in summer than in winter to prevent excessive souring in summer and difficult handling in winter.

Effect of These Factors upon the Skimming Efficiency of the Separator.—The richness of the milk has no effect on the completeness of the skimming.

The richness of the cream, within reasonable limits, has no effect on the completeness of the skimming. The skimming of very rich cream causes a large loss of fat in the skim-milk in the case of certain makes of separators, due to the clogging of the machine.

The Rate of Inflow Greatly Affects the Completeness of the Skimming.—If more milk is run into the machine than the capacity of the machine calls for, there is excessive loss of fat in the skim-milk. If the rate of inflow is reduced below the capacity of the skim-milk outlet, the separator delivers no cream at all.

The Speed of the Separator Greatly Influences its Skimming Efficiency.—Excessive speed does not increase the completeness of the skimming. Insufficient speed increases the loss of fat in the skim-milk. A separator run at half speed may cause one-half of the fat of the milk to be lost in the skim-milk.

The Temperature of the Milk Affects the Skimming Efficiency of the Separator.—For all practical purposes a temperature of 90° F. causes efficient skimming. At lower temperatures there is excessive loss of fat in the skim-milk.

The Amount of Water or Skim-milk used to Flush the Bowl Regulates the Amount of Fat Lost in the Bowl and Pan. If the bowl is not flushed at all, or insufficiently, varying amounts of fat may be lost. If the bowl is flushed until the cream discharge is watery, most of the fat in the bowl and pan is recovered and saved.

CHAPTER VIII

RECEIVING, SAMPLING, GRADING AND TESTING MILK AND CREAM

Receiving and Grading of Milk and Cream.—The man who receives and samples milk at a creamery should be accurate and quick at figures, have ability to grade and select milk, and to stimulate interest in the production of good milk. He should also be able to reconcile and satisfy patrons. The method employed in some creameries of allowing a boy with immature judgment to weigh and sample milk should not be tolerated. The person who weighs and samples milk and cream comes in direct contact with the patrons. Therefore, he is a strong factor in serving the best interests of the creamery. In many of the best butter and cheese factories in the country the head maker or manager in charge is usually found at the weighing can. This gives him the opportunity of studying the raw material from which he is expected to make a high grade of butter or cheese. Some of our large central plants pay the highest salary to the man who has the ability properly to grade the cream and prepare the starters. This requires a fine sense of smell and taste, which is not possessed by everyone.

The first step in the receiving of milk is to ascertain the quality of the milk delivered by the patrons. It is now a recognized fact that the best butter cannot be produced from defective or abnormal milk or cream, no matter how many improved methods are employed in the manufacture. In view of this fact, and of the knowledge we now have of the transmission of undesirable germs from one sample of milk to another, and also the probability that some of the patrons will deliver poor milk, it is essential that the milk or cream be graded when it is delivered at the creamery.

In the grading of milk or cream, different methods can be used for detecting abnormal milk: (1) through the senses, taste, sight, and smell; (2) by the acid tests; (3) by the fermentation test; (4) by heating; (5) by the Babcock test and the lactometer.

While all of these tests are applicable to the grading of milk, only the first and a portion of the fifth are usually applied to cream.

1. Detection of Abnormal Milk and Cream through the Senses.—In order to detect the different kinds of defective milk one must be endowed with acute senses of smell, taste, and sight. When the milk is in a good condition, it has a pleasant smell and sweet taste, and appears normal. This applies equally to cream with the exception that not all cream for butter-making is sweet. If milk has a disagreeable smell and taste it cannot produce good butter. As a rule, the quantity of defective milk brought into the average creamery is much in excess of that of really perfect milk. As a consequence it would not be practicable to separate all the defective milk into one class and the perfect into another. The question as to where the line should be drawn between the good, medium, and very bad milk or cream, must depend upon the judgment of the receiver, and in a great measure upon the local conditions. Some of the creameries have no facilities for handling different grades of milk, and some sell butter on a market where no sharp distinction is made between good and poor butter. Others have, through experience, satisfied themselves that under American creamery conditions it does not pay to make too many grades, nor does it pay to grade too closely. Two, or at the most three, grades of butter can at times be manufactured in one creamery profitably. It is advisable to reject sour and abnormal milk. If accepted, it should not be mixed with the remainder of the milk, as it might contaminate all of it; or, the sour milk might cause coagulation, and thereby clog up the separators. If a can of milk is sour, but otherwise clean, it is not necessarily unfit for the production of first-class butter. If retained until after the sweet milk has been skimmed, it may be run through the separator successfully.

2. The Use of Acid Tests.—Some creameries are now grading the milk or cream according to the amount of acid it contains. Mann's and Farrington's acid tests can both be used, but a more rapid and convenient way is to use a solution prepared from Farrington's tablets. The solution is prepared by dissolving the tablet in warm water, using an ounce of water to a tablet. When one part of this alkaline solution and one part of milk are mixed together in a cup and the solution still retains a pink color, it shows that there is less than .1 per cent acid in the sample tested. If two parts of alkali and one part of milk are mixed and the mixture remains pink, then there is less than .2 per cent of acid. If the mixture becomes colorless, it shows there is more than .2 per cent acid in the sample. If three measures of alkali to one measure of milk are taken, and the mixture remains pink, there is less than .3 per cent of acid, etc. By means of such a test the acidity can quickly be determined.

The sample cups should be numbered to correspond with the number of each patron. The results of the tests should be noticed at once, as the action of the atmosphere affects the color.

The acid tests are of value in grading cream, as a sour sample of milk or cream is either old or has been improperly kept and handled. The number of grades of cream and milk and the maximum limit of acid each grade can contain, are factors which must be decided according to local conditions, by the operator.

3. Use of the Fermentation Tests.—Curdled, ropy, red and blue milk can, as a rule, be readily detected without the application of a special test, but there are cases when a person's senses are not sufficiently acute to detect samples of milk containing undesirable fermentations. Several instances have recently come within the authors' notice. A neighboring creamery was infested with a peculiar fermentation that caused a very rank flavor in the butter. The milk that came to the creamery was carefully examined, but the source of the trouble could not be located. The cause could not be ascertained without the use of the fermentation test.

It is in such instances that a fermentation test is of special value. As a rule, the trouble is first caused by milk from one

particular patron. This milk may appear to be normal, and yet contain germs which are very undesirable for the manufacture of the best quality of butter.

Fermentation Tests.—There are two tests which may be of general use; namely, the “Wisconsin Curd Test” and the “Gerber Fermentation Test.” The former is used in cheese factories, but the latter is to be recommended in testing milk for butter-making.

Gerber Test.—The apparatus for this test consists of properly made glass tubes resting upon a rack which fits into a small round tin tank, about two-thirds full of water. The temperature of this water can be controlled by means of a lamp kept burning underneath, or by the use of steam. The milk delivered by different patrons is put into the glass tubes, and these are numbered so as to indicate to which patron each belongs. The temperature should be kept at about 104° to 106° F. for about six hours. Then the tubes are taken out, the milk shaken, and the appearance, smell, and taste of the milk noted. The tubes are warmed again for about another six hours, when they are again examined. If any samples contain a preponderance of abnormal ferments, the fact will usually appear in less than eighteen hours. If milk does not coagulate in twelve hours, or become abnormal in some way, it is considered good.

The special apparatus mentioned above is not absolutely essential, nor is the temperature employed considered by the authors to be the most suitable to give reliable results. Ordinary sample jars can be used, instead of specially prepared tubes. After the milk has been placed in the jars they can be kept in any convenient place, at a temperature of about 98° F. The best place to keep them is in a vessel containing water, the temperature of which can be controlled.

Wisconsin Curd Test.—This test consists of taking some milk in a jar and adding about ten drops of rennet, which coagulates the milk. The sample is allowed to stand until the curd hardens, when it is cut into small pieces with a case knife; the whey is drawn off, and the curd allowed to stand at a temperature of 98° F. If there are any undesirable forms of bacteria present,

they will reveal themselves by developing small holes in the curd, usually accompanied by a bad odor.

This test is a very ingenious one for cheese-making. In butter-making the Gerber Fermentation Test, or a similar one, is more convenient.

4. **Grading Milk by Heating.**—This test is not very much

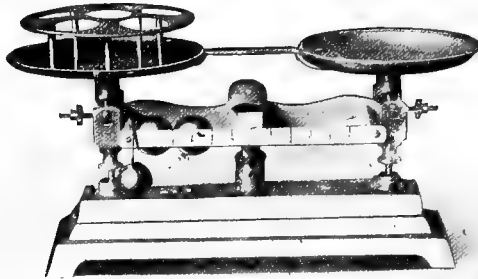

FIG. 18.—Troemner's Babcock cream-testing scales.

used in creameries; but in cheese factories the heating of milk in order to ascertain its suitability for cheese-making is practiced to a considerable extent. The heating test, which is in common use in Canada, consists of heating a small sample of the milk to be tested to 120° F. If it will stand this temperature without coagulating, it is considered to be good milk. If it coagulates when heated to this temperature, it is too sour to be used for cheese.

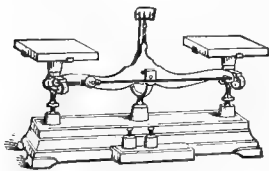

FIG. 19.—Troemner's Babcock cream-testing scales.

This heating may be considered an acid test. When milk contains about .3 per cent acid, it usually coagulates when heated. It should be borne in mind in this connection that different samples of milk, containing exactly the same amount of acid, do not coagulate at the same temperature. Some samples will coagulate upon heating when containing a little less than .3 per cent acid, while others will not coagulate until more than .3 per cent acid has developed.

In practice the temperature (120° F.) is not always closely

adhered to. A small portion of the sample to be tested is put into a tin cup, and the cup is put into hot water or over a jet of steam. When the milk is hot its characteristics are noticed.

5. Use of Babcock Test and Lactometer.—These tests are of special value in detecting watered or skimmed milk. Whenever a sample of milk appears watery or blue, it is fair to presume that water has been added. The test for specific gravity and the test for fat can then be applied to such samples of milk. As a rule composite samples are taken daily at creameries, and the patrons

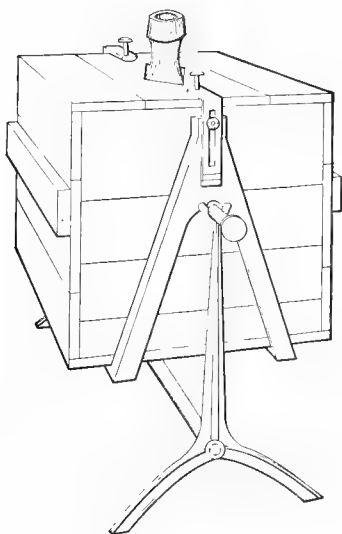

FIG. 20.—Acid carboy trunnion.



FIG. 21.—Acid hydrometer.

paid according to the fat delivered. For this reason water adulteration is not very common at creameries, but is practiced to a greater extent in the milk-supplies of cities. The use of the lactometer in connection with the Babcock test has already been referred to under the heading of "Specific Gravity of Milk."

The Babcock test is now in such general use in America for determining the per cent of fat in milk and cream that no other will be dealt with here. At one time the Oil-test Churn was used quite exclusively for testing cream, but it has gone almost entirely out of use.

The Babcock test always deals with weight. For instance, when we say that a sample of milk tests 4.0 per cent or that a sample of cream tests 30.0 per cent, we mean that in 100 pounds of the milk there are 4 pounds of fat, or in 100 pounds of the cream there are 30 pounds of fat.

For the sake of convenience a sample may be measured into a test bottle instead of being weighed, when the accuracy of the result is not likely to be affected. Milk may be sampled for the Babcock test with a pipette, because the specific gravity of milk is always so nearly the same that the same measure of milk from widely different sources has, for all practical purposes, the same weight, and because milk is in such a liquid condition that it neither holds air nor adheres to the wall of the pipette. Rich cream, on the other hand, has a lower specific gravity than thin cream; moreover, cream is so syrupy or viscous in its nature that it will hold air or other gas and stick to the wall of the pipette. For these different reasons, the authors wish to state emphatically, that when cream is tested for commercial purposes, as at a creamery, it should never be measured but always weighed into the test bottle. The measuring of cream for the Babcock test, when this test is made for commercial purposes, is a fraudulent practice; and in most of the States and Provinces of the United States and Canada there are laws prohibiting it.

In taking the sample for a Babcock test of milk a 17.6 c.c. pipette is used. This will deliver 18 grams of milk, the quantity for which the scale on the test bottle is graduated to read per cent of fat. To this we add 17.5 c.c. of sulphuric acid (specific gravity 1.82-1.83), varying the quantity to suit the strength. The contents are then thoroughly mixed by giving the bottle a rotary motion. The acid acts upon and digests all the solids of the milk, excepting the fat, and heats the sample to a desirable high temperature. The bottle is then placed in the centrifugal tester and whirled for five to six minutes, at a speed suitable to the diameter of the machine, usually 800 to 1000 revolutions per minute. The bottle is then filled to the bottom of the neck with hot water (soft or distilled) and whirled for about two minutes. A second addition of hot water is then made to float the

fat into the neck to about the 8 per cent mark, after which the sample is given a final whirling of one minute. The sample is then set in hot water at 130° – 140° F. to bring it to the right temperature for reading. A pair of dividers is generally used for measuring the fat column in taking the reading. With milk, the reading is taken from the highest to the lowest point, that is, the meniscus of the fat column is included.

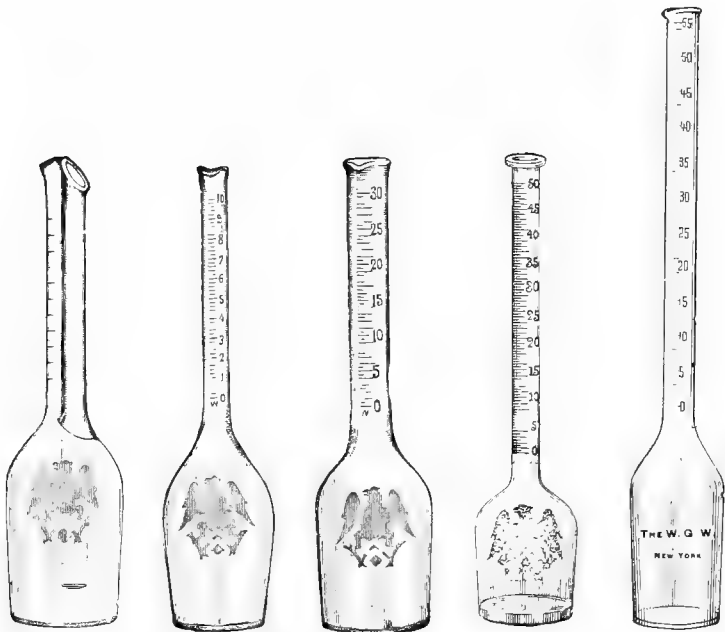

FIG. 22. Skim-milk test-bottle.
 FIG. 23. Whole-milk test-bottle.
 FIG. 24. Cream test-bottle.
 FIG. 25. 9-gram cream test-bottle.
 FIG. 26. Cream test-bottle.
 Babcock Test-bottles.

In the Babcock test of cream either a 9- or an 18-gram bottle is used. The drift has been decidedly towards the use of the bottle graduated to read per cent for 9 grams. A 9-gram sample of cream is weighed into the bottle by means of a special cream scale. To this are added about 9 c.c. of commercial sulphuric acid, and the contents are mixed by giving the bottle a rotary motion. When the action of the acid has proceeded far enough—

when the contents have reached a chocolate color—some hot water is added to the test bottle to check the action of the acid. The sample is then centrifuged for five to six minutes, after which hot water is added to float the fat into the neck of the bottle; then the sample is again whirled for two minutes. The reading is taken at a temperature of 130° – 140° F., after a few drops of a colored reader, composed of a light mineral oil with suitable coloring matter in it, have been added to flatten the meniscus. Dividers are used for measuring the fat column in taking the reading.

There are three very common conditions which make it difficult to obtain a fat reading: (1) Black, charred, flocculent matter is sometimes found at the bottom of the fat column. This is commonly caused by using too much or too strong acid or by mixing milk and acid at too high a temperature. The remedy is to use less acid or to cool milk and acid before mixing. The black charred matter may also be due to allowing the acid to stand in contact with the milk too long a time before mixing or to pouring acid through the center of the milk. (2) There may be a layer of white flocculent matter at the bottom of the fat column. In this case an insufficient quantity of acid may have been used, the temperature of the milk and acid may be too low, or they may not have been thoroughly mixed. The remedy is to use more acid, to warm milk and acid before mixing, or to shake the mixture thoroughly before whirling. (3) Occasionally there is a layer of impure foam at the top of the fat column. This is generally due to the use of hard and impure water. The remedy is to use pure distilled hot water. For more detailed information on this subject see "Testing Milk and its Products," by Farrington and Woll.

Does the Babcock Test, as Ordinarily Applied to Cream, Give too High a Reading?—An investigation made by Harry B. Siegmund, Analyst, Hendler Creamery Company, and R. Sewell Craig, Senior Food Chemist, City Health Department, Baltimore, resulted in a decision that the Babcock test of cream, as ordinarily conducted, gives too high a reading. The following is a brief summary of the results obtained:

When the centrifuging was done in a thirty-six bottle, electrically driven machine, run at a speed of 1000 revolutions per minute, the average of the tests of a number of samples of cream was 1.0 per cent higher than that obtained by gravimetric analysis (Rose-Gottlieb test); and where the test was made with a twenty-four bottle steam-turbine machine, run at a speed of 800 revolutions per minute, the average test was 1.5 per cent too high.

With the electrically driven machine run at a speed of 1200 revolutions per minute the reading was 0.6 per cent higher than that obtained by the Rose-Gottlieb test.

When an electrically driven machine, run at a speed of 1600 revolutions per minute, was used, the Babcock test and the Rose-Gottlieb test gave practically the same results.

The conclusion was that with machines run at the lower speeds a little water, or water and acid, remains suspended in the fat, and that it requires the force created by the higher speed machine completely to separate this from the fat.

Babcock Test of Buttermilk and Skim-milk—The American Association Test.—In an exhaustive investigation of the losses of fat in buttermilk, conducted by Professor J. W. Mitchell under the direction of the senior author and not yet completed, several points have come prominently to the fore.

The first of these is that the losses of fat in buttermilk, in our creameries, are much greater than they are generally supposed to be. Many creameries, under their methods of testing, are getting tests of .1 per cent to .2 per cent fat for their buttermilk. Of between 250 and 300 complete records, made by Professor Mitchell and the author, of churnings at different creameries, not one showed a Babcock test as low as .2 per cent. Of course the test was rigorous, but even this was considerably below the chemical analysis.

The second point is that there are a large number of factors which influence the per cent of fat in the buttermilk, such as length of time taken to churn, temperature of cream, length of time the cream is held at churning temperature, condition of cream, fullness of churn, speed of churn, etc. This means that

every creamery has its own conditions and problems to meet, and consequently should be in a position to determine, readily and accurately, what its losses of fat in the buttermilk are. It will then be in a position to study how to reduce them.

The third point is that the average creamery, under its methods of testing, is not aware of what its losses are. It is not uncommon to note, in creamery records, tests of .1 per cent to .2 per cent for the buttermilk, whereas it is known, from hundreds of analyses made in the laboratory of the American Association of Creamery Butter Manufacturers, that the average loss exceeds .5 per cent fat. The loss does not fall far short of a pound of butter to every hundred pounds of buttermilk.

Realizing the necessity for a simple test that would correspond closely with chemical analysis for buttermilk (or skim-milk), and that could be operated by anyone capable of conducting a Babcock test, the senior author asked Professor Mitchell to devise such a test, if possible. In his efforts he has fortunately been very successful.

The different methods of making a Babcock test of buttermilk, including the new modification of the same, are briefly outlined below.

The following method of testing buttermilk (or skim-milk) has been in use for many years, and is still more generally used than any other. A double-necked skim-milk bottle, graduated to read as close as .01 per cent for 18 grams, is used. Most of the bottles read up to .25 per cent—some to .50 per cent. After the buttermilk is well mixed, a 17.6 c.c. pipette is used to transfer 18 grams of it to the test bottle. To this is added 20 c.c. of commercial sulphuric acid (sp. gr. 1.82–1.83). The acid and milk are then thoroughly mixed by giving the bottle a gentle, rotary motion. Care must be exercised, in mixing, to avoid choking the small neck and causing some of the contents to be thrown out through the large neck. The bottle is then placed in the centrifuge and whirled at full speed for about five minutes. Hot water (soft or distilled) is then added to the bottle to fill it almost to the neck and the machine is again run for one or two minutes. Hot water is then added to float the fat into the small

neck and the bottle is again whirled for one or two minutes. The bottle is then placed in hot water at a temperature of 130° – 140° F., after which the reading is taken. It is advisable to use a pair of dividers to measure the fat column. Under this method the reading will be very low—possibly .1 per cent to .2 per cent when it should be .4 or .5 per cent.

A More Rigorous Test.—A modification of the foregoing is to take a 9-gram sample by means of a 9 c.c. pipette, that is, a half sample. To this is added about 12 c.c. of a fairly strong acid, well up to a sp. gr. of 1.83. The whirling is done in a very high-speed machine and is greatly prolonged—fifteen to twenty minutes the first time, about ten minutes at the second whirling, and about five minutes at the third whirling, or thirty to thirty-five minutes in all. The reading must be doubled, since only a 9-gram or half sample is taken to a test. This method will probably double, or more than double, the result. But even under this method the test falls considerably below the results secured by chemical analysis.

The American Association Test.—A close study of the different practical methods for the quick determination of the per cent of fat in milk and its products and by-products reveals the fact that there is a general principle running through them all, that is, there are three factors which operate in all of them. These are (1) the use of one or more chemicals to liberate the fat, (2) the heating of the contents of the test bottle in order to liquefy the fat, and (3) the application of centrifugal force. Where sulphuric acid is the chief or only chemical used it generates sufficient heat, through its strong affinity for water; but where it is not used at all or is used very sparingly it becomes necessary to heat the sample in hot water before centrifuging it.

A number of useful tests have been devised for the quick determination of the per cent of fat in milk, etc. The following are a few of the most outstanding of these:

(1) The Lactocrite, devised in 1886 by Dr. De Laval, inventor of the cream separator which bears his name. The chemical used was concentrated or glacial acetic acid, containing 5 per cent of concentrated sulphuric acid. It was necessary to heat

the sample before centrifuging it. This was a pioneer test but is not now in use.

(2) The Babcock test, invented by Dr. Babcock of the Wisconsin Experiment Station and published in July, 1890. This test is so widely and favorably known and is in such general use, especially in America, that it seems unnecessary to do more than refer to it. It is simple, speedy and accurate, and the cost of a test is small, a single, cheap chemical, commercial sulphuric acid, being used.

(3) The Gerber test, brought out in 1892. In this test two chemicals are used, viz., commercial sulphuric acid and amyl alcohol. It is used quite extensively in Europe.

(4) The Sinacid Butyrometer. This test was devised by Sichler of Germany in 1904. No acid is used in the test, hence the name "Sinacid." The chemicals used are sodium hydroxide, Rochelle salt and iso-butyl alcohol. It is necessary to heat the samples by placing them in hot water before centrifuging them.

All of these tests were designed primarily for the testing of milk and such milk products as cream, and for this purpose they are reliable; but in testing the by-products of the dairy, skim-milk and buttermilk, they all give results that fall considerably below those obtained by chemical analysis (the Rose-Gottlieb test). No doubt this is the main reason for the failure there has been to make a thorough study of the losses of fat in buttermilk and how to overcome them. Hence, when the American Association of Creamery Butter Manufacturers began its study of losses of fat in buttermilk it was confronted with the problem of devising a suitable test for the accurate determination of the per cent of fat in buttermilk,

Trials were made of different combinations of chemicals, such as, sulphuric acid and amyl alcohol, sulphuric acid and iso-butyl alcohol, and sulphuric acid and normal butyl (*n*-butyl) alcohol. After extensive experiments had been made sulphuric acid and *n*-butyl alcohol were selected as the most suitable combination to use, and for the following reasons:

(1) The results, with duplicate tests, are exceptionally uni-

form and correspond closely to chemical analysis (The Rose-Gottlieb test), as the accompanying table shows.

(2) There is much less trouble with a deposit in the test bottles than is the case where the other alcohols are used.

(3) Normal butyl (*n*-butyl) alcohol, being a single alcohol that is readily purified, is free of impurities while the amyl and iso-butyl alcohols are not likely to be. In blank tests made, that is, when water was substituted for buttermilk in a test, a short column of some impurity rose into the neck of the test bottle when the amyl and iso-butyl alcohols were used, but not when *n*-butyl alcohol was used.

(4) The *n*-butyl alcohol is quite stable and is not at all likely to be attacked by the sulphuric acid, while the other alcohols mentioned are iso-alcohols that run off into chains and are less stable and are likely to be mixtures.

(5) The *n*-butyl alcohol does not possess either a pungent or an otherwise offensive flavor or odor, and consequently is much pleasanter to use than the others.

(6) The *n*-butyl alcohol is the lowest in price of the different alcohols, and, being stable and free of impurities, is the most reliable alcohol to use. Even the cheaper grade of this alcohol (the "practical") contains no impurity excepting possibly a slight amount of moisture.

Extensive and carefully conducted investigations have shown that the right amounts of commercial sulphuric acid and *n*-butyl alcohol to use in testing a 9-gram sample of skim-milk or butter-milk are as given in the directions which follow:

Directions for making a test:

Chemicals.—Commercial sulphuric acid.

Normal butyl alcohol.

1. Place the chemicals and buttermilk in the test bottle in the following amounts and the order indicated.

(a) 2 c.c. of *n*-butyl alcohol.

(b) 9 c.c. of buttermilk.

(c) 7 to 9 c.c. of commercial sulphuric acid.

Vary amount of acid to suit its strength. The right amount

is being used when the fat column is golden yellow to light amber in color.

2. Mix contents of bottle thoroughly.
3. Centrifuge for six minutes.
4. Add hot water (soft or distilled) to fill bottle to bottom of neck, and whirl for two minutes.
5. Add balance of water to float fat into neck and again whirl for two minutes.
6. Read at temperature of 130° to 140° F. Double the reading to obtain per cent of fat.
7. In cleaning test bottle—especially if there be any deposit—first add a small amount of lukewarm water and to this add sulphuric acid. Always add the water first and then the acid—never the reverse. Rinse the bottle well with this mixture and then rinse with hot water.

This test gives results corresponding to those of chemical analysis.

A test bottle, with a scale reading up to .50 per cent for 18 grams, should be used.

The following table, comparing the Babcock, The American Association Test, and Rose-Gottlieb (Chemical) tests, is submitted.

Babcock Test ¹	The American Association Test	Rose-Gottlieb Test
Per Cent	Per Cent	Per Cent
.38	.52	.52
.34	.47	.47
.40	.57	.59
.43	.60	.60
.36	.54	.53
.39	.56	.59
.36	.50	.52
.34	.50	.48

¹The Babcock test given in the foregoing table was that obtained from using 12 c.c. of sulphuric acid with a 9-gram sample and centrifuging, in all, about thirty-five minutes in a high-speed tester.

Determination of the Per Cent of Fat in Butter.—The methods for the determination of the per cent of fat in butter may be classified under two heads, viz.,

- (1) Scientific methods, such as
 - (a) The Extraction method.
 - (b) Rose-Gottlieb method.
 - (c) Indirect determination of fat.
- (2) Practical methods, such as
 - (a) The 90 per cent bottle designed by Hepburn for use in the Babcock test.
 - (b) The Shaw test.

Scientific Methods.—The scientific methods are too complicated and require too long a time for their completion to be of practical use in a creamery.

The Rose-Gottlieb method may be briefly outlined as follows:

This method, which was originally designed for the estimation of fat in milk, can be used with advantage also for the determination of fat in butter.

According to A. Hesse,¹ about 2 grams of butter are weighed out into a 3 cm. long, half-cylindrical glass tube, or simply wrapped in a piece of stiff fat-free paper of the same form. The tube or paper and the contained fat are then introduced into a Gottlieb cylinder, and hot water is added until the 10-cm. mark is reached. If the butter does not melt, the cylinder is placed in warm water until it does. Then 1 c.c. of ammonia and 10 c.c. of 95 per cent alcohol are added, exactly as in the estimation of milk-fat. If the mixture is still warm, the cylinder is cooled in cold water so that the ether which is to be added will not evaporate too quickly. The cooling must not, however, be carried too far; otherwise the butter will become solid again. Twenty-five c.c. of ether are then added, and the contents of the cylinder mixed by repeatedly inverting it. Afterwards 25 c.c. of petroleum ether are added and the mixing repeated.

After the different layers have separated quite sharply from one another, the clear ether-fat solution is siphoned off in the usual way, the lower opaque layer not being disturbed. Then

¹ Molkerei-Zeitung, Hildesheim, 1903, No. 27.

50 c.c. of ether are poured into the cylinder and at once siphoned off without being mixed with the other liquid. Finally, the residual liquid is shaken with a mixture of 25 c.c. ether and 25 c.c. petroleum ether, and, after settling, the ethereal layer is drawn off. The three portions of ether are naturally all placed in the same tared flask, which is weighed again after the ether has been evaporated and the fat dried.

These repeated extractions with ether and petroleum ether are necessary if exact results are to be obtained. If the above directions are carefully followed, it will be found that the Rose-Gottlieb method, while easier and more convenient, and also considerably quicker than the extraction method, gives results which are in very close agreement with those obtained by the latter.

The Mojonnier test is a modification of the foregoing, and possesses several features which greatly facilitate the work and shorten the time required to make the test. In the method known as the "Indirect Determination of Fat," the percentages of moisture, casein and salt are carefully determined. These are then added together and their total is subtracted from 100 to determine the per cent of fat in the butter.

Practical Methods.—There are several practical methods that are made use of to a greater or less extent. We shall briefly outline two of these.

For making a Babcock test of butter, using the Illinois 9-inch, 9-gram, 90 per cent butter test bottle devised by Dr. N. W. Hepburn, University of Illinois, the following directions are given:

"Taking the Sample.—In testing butter it is necessary to exercise great care both in securing and in preparing the sample.

"Sampling from a Churn.—With an ordinary ladle cut off the surface of the butter in several places, including each end and the middle of the churn. Then make a composite sample by taking, with a spatula or common case knife, a small sample (10 to 20 grams each) from six or eight different places in the churn where the surface has been removed, putting them into an 8-ounce wide-mouthed glass-stoppered bottle.

“*Sampling from a Tub.*—Draw one or two triers from the full depth of the tub and drop the entire plug of butter into the glass-stoppered bottle.

“*Preparing the Sample for Testing.*—Place the glass-stoppered bottle containing the sample in warm water, shaking vigorously every few seconds until it is thoroughly mixed and is about the consistency of heavy cream, when it is ready to be weighed into test bottle. CAUTION.—Be careful not to get the sample too warm nor in too liquid a condition. If this happens place it in cold water, shaking very frequently, until the sample takes on the desired consistency. Samples should not pour freely, but like thick cream or paste. Little heating and thorough shaking is the rule for success in preparing the sample.

“*Weighing the Sample.*—Balance the bottle on the scales and weigh out a 9-gram sample by the method used in weighing cream samples. (Scales as sensitive as moisture-test scales should be used.)

“*Adding Acid.*—First add about 9 c.c. of water then 17.5 c.c. of sulphuric acid. CAUTION.—Add the acid slowly and in small portions, shaking after adding each portion to avoid foaming. High-salt samples are most likely to foam. If foaming occurs, vigorous shaking will often prevent the loss of the sample. After the sample is thoroughly mixed with the acid and is dark brown in color, add warm water, filling the test bottle up to the base of the neck.

“*Whirling.*—Place the test bottles in the tester and whirl for ten minutes; stop, fill with water to bring the fat up in the graduated neck, and whirl again for five minutes.

“*Reading.*—Set the test bottle in water at 140° F., covering the fat in the neck, and allow it to stand for at least five minutes; then read. In read-



FIG. 27.—Illinois 9 inch, 9 gram, 90 per cent butter test bottle.

ing, cut off all the upper curve on the fat column or add a couple of drops of white mineral oil (glymol) to destroy the meniscus."

THE SHAW TEST FOR FAT IN BUTTER

APPARATUS REQUIRED

" Babcock centrifuge or tester.¹

" Shaw separatory funnels.

" Balance which is sensitive to 0.01 gram. (A torsion balance, such as is used in testing for moisture, will answer if it is in good condition.)

" Accurate set of metric weights.

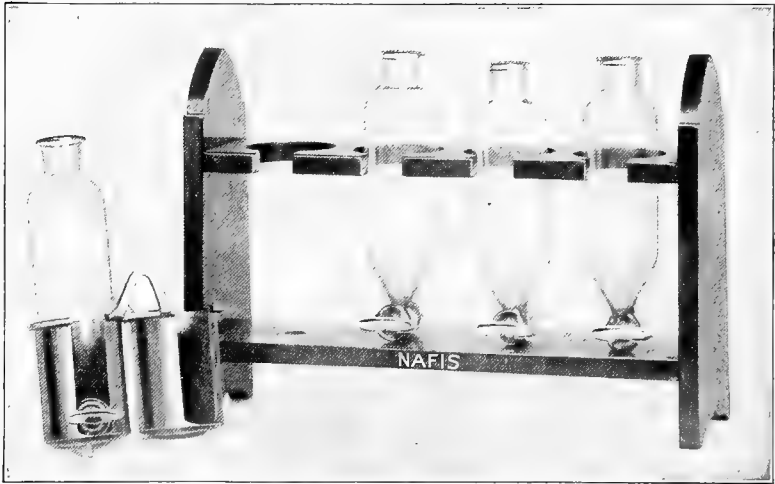

FIG. 28 —Separatory funnels used in the Shaw test.

" Glass cylinder graduated at 9 and 11 c.c.

" 100-c.c. glass beaker.

" Wooden rack for holding separatory funnels.

" Support for separatory funnels on balance.

" In addition to the above a special socket to hold the separatory funnels will be required. As shown in the cut, this differs in no material way from the socket ordinarily used in the Bab-

¹L. F. Nafis.

cock centrifuge, except for the opening in the side. It may easily be adapted from the ordinary socket or if preferred the socket may be sent to us and we will make the necessary changes for a nominal charge. Care must be taken that the capillary stem of the funnel does not project far enough through the hole in the socket to strike against the side of the centrifuge while being whirled. It is a good plan to fit a disk of rubber gasketing in the bottom of the socket.

SAMPLING THE BUTTER

“In the determination of fat in butter, great care must be taken in securing a representative sample and in preparing this for the test.

“Several samples from different parts of the tub or churn should be taken with a butter trier. These are placed in a suitable container, such as a 1-pint Mason preserve jar or a cup, which is placed in water at about 100° F. The sample is then mixed with a spatula or spoon until about the consistency of thick cream. The sample must not be left any length of time in open containers, since some of the moisture will evaporate. Should the sample be kept for any reason for a day or two before it is mixed, it should then be placed in warm water (with the cover on the container) until melted, and then cooled while being vigorously shaken until it solidifies. The reason for this is that on standing some of the water will ooze out and cannot be reincorporated except by emulsifying and cooling while in this condition. Too much stress cannot be laid on careful sampling and mixing the sample, for upon this the accuracy of any determination in butter very largely rests.

DETERMINING THE FAT

“It will be found more economical in some cases if four or multiples of four determinations are made at once. In this case the two double sockets containing the funnels will balance when placed opposite in the centrifuge. If but one or two determinations are to be made it will be necessary to balance the centrifuge by putting weights in the opposite socket. First of all, the clean

and dry separatory funnel must be weighed, and this as well as the other weighings involved must be done with care. This weight once found will suffice for all determinations made with that particular funnel, unless by accident some of the glass should be chipped off. A slight scratch made with a file can serve to identify the funnels. A paper label should not be used. If requested at the time of ordering we will number them without additional charge.

“ Each time, before using the separatory funnels, they should be lubricated with a properly prepared stopcock lubricant which we supply with directions for its use.

“ **I. Weighing the Charge.**—Counterpoise the small beaker on the balance and carefully weigh out 20 grams of the sample mixed as directed.

“ **II. Transferring the Charge to the Separatory Funnel.**—Place the beaker containing the charge on a radiator or steam pipe until the butter is melted. (This may also be accomplished by adding a small quantity of boiling water.) Next pour the charge into the funnel kept in an upright position in the wooden rack. No part of the charge must be lost in transferring. With a fine stream of hot water rinse down the sides of the beaker and pour the rinsings into the funnel. (If the salt is to be determined, distilled water must be used. See directions under ‘Salt Test.’) Repeat this, using not more than a teaspoonful of water at a time until the funnel is full to within about one-quarter of an inch of the shoulder. The rinsing can be done very conveniently with the arrangement on many steam centrifuges for filling the Babcock test bottles, i.e., the rubber tube ending in a glass or metal point and connecting with a water tank heated by steam. The point must be fine, however. Should it be larger than three-sixteenths of an inch, it can be replaced with the tip of a small oil can. Should this arrangement not be at hand, one can easily be improvised from a tin can, a rubber tube, and an oil-can tip. In transferring the melted butter and rinsings, the last drop may be prevented from running down the outside of the beaker by touching the lip of the beaker to the neck of the separatory funnel.

“ **III. Centrifuging.**—Insert the separatory funnel in the special socket, allowing the stem to project through the hole in the bottom and the handle of the stopcock through the open side. **CAUTION.**—The socket must always be placed in the centrifuge, with the open side facing the direction in which the wheel revolves. This is very important, if the opening faces the reverse direction the stopcock will be thrown out and broken. Whirl one minute at the same speed used in testing milk with the Babcock test. The centrifuge must be kept warm.

“ **IV. Removing the Water.** Remove the separatory funnel from the socket and allow the water to flow through the stopcock until the fat (or curd) is within one-eighth of an inch of the stopcock. In this and later operations involving the stopcock one must be sure it does not stick. It must always be under control, and it is best to give it frequent slight movements when the water or acid is running through it to be sure that this control is maintained; otherwise it might stick at a critical moment and the determination be lost. The most of the salt and part of the curd are taken out by the water. The remainder of the curd and all of the fat stays in the funnel. If it is desired to determine the salt, this wash water is allowed to run into a 250 c.c. flask and the operation described in this paragraph conducted three times instead of but once, the wash water being added each time to the flask.

“ It sometimes happens that the water will not start flowing when the stopcock is opened, in which case it can be started by blowing into the mouth of the separatory funnel.

“ **V. Dissolving the Curd.**—Measure out 9 c.c. of cold water, preferably condensed steam, with the glass graduate and pour into the beaker. Add to this 11 c.c. of sulphuric acid of the same strength used in testing milk and cream (specific gravity, 1.82-1.83) and mix by gently shaking. (**CAUTION.**—Always add acid to water and not water to acid, or a serious accident may result.) While still very hot add the mixture to the contents of the separatory funnel. Now dissolve the curd by giving the funnel a circular motion with the hand grasping the neck. Centrifuge one minute, as before. Draw off the acid solution till the fat

layer is within about one-fourth of an inch of the stopcock and repeat the operations in this paragraph.

“**VI. Freeing the Fat from the Acid Solution.**—The fat will now be in a clear transparent layer free from curd, and the solution below it will be practically colorless. To separate these two draw off the latter until the fat nearly reaches the stopcock and centrifuge another minute. Now allow the fat to come down through the stopcock till it just reaches the end of the capillary stem. This last step offers no difficulties, providing the stopcock is kept in control, but it requires care. If desired, the acid may be colored with methyl orange.

“**VII. Determining the Percentage of Fat.**—Carefully dry the separatory funnel on the outside with a clean soft cloth and weigh it. The weight thus obtained minus the weight of the empty funnel represents the weight of butter-fat in 20 grams of the sample. The percentage is obtained by multiplying by 5.

“Often it is possible to obtain a clear fat layer with but one addition of acid, but in some cases it will be found necessary to add it the second time, as directed. The test for fat alone involves 4 centrifugings of one minute each. The centrifuge should be kept warm and the contents of the funnel in a melted state when the acid is added. The time consumed should not be longer than it takes to test cream with the Babcock test, and the operations involved are simple and easily learned. No difficulty will be experienced in obtaining a clear fat. Occasionally there will appear a slight emulsion at the bottom of the fat layers when the fat is drawn into the stem. This is so small in amount that it does not seem to affect the accuracy of the test to any considerable extent. The emulsion should be weighed as fat and considered as such.

CLEANING THE SEPARATORY FUNNELS

“The separatory funnels should be washed after each determination, but it is not necessary to dry them before use, providing their weight, when clean and dry, has been found. The cleaning is easily done with hot water and either soap or cleansing powder. They should be well rinsed off with clean water and drained.”



FIG. 29.—Churn room. Kirschbraun & Son, Omaha, Neb. One of the largest and finest creameries in the world.

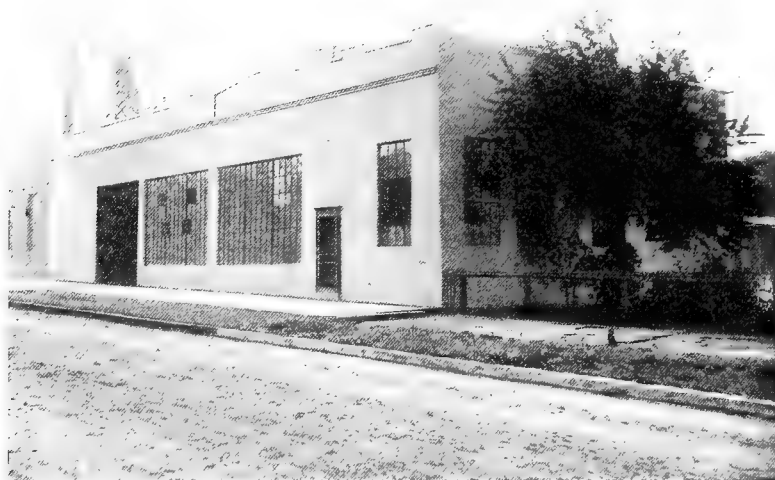

FIG. 30.—Street view of the first prize co-operative creamery at Carroll, Iowa.

Very few of the creameries have, as yet, begun the regular determination of the per cent of fat in their butter, most of them confining their work on the composition of butter to determinations of the per cent of moisture and the per cent of salt. The three constituents of butter outside the fat, are moisture, salt and curd; and where a uniform system of manufacture is adopted, and the churning is done under right conditions and the butter well washed, the curd content is not likely to exceed 1 per cent

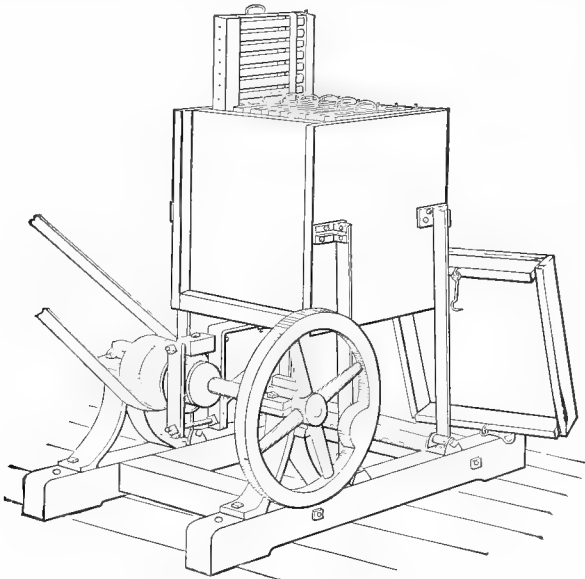

FIG. 31.—The oil-test churn.

or vary more than half a per cent. Consequently accurate determination of the moisture and salt-contents enables a creamery to estimate, very closely, the per cent of fat in the butter.

Sediment Test.—Milk should be free from sediment and foreign insoluble material. Producers of the raw material are not always conscious of the necessity of producing clean milk, and of the effects of impurities upon the finished products.

Sediments may be seen on the bottom of a glass jar after the

milk has stood quietly for several hours. The better way of showing these sediments is to use the Wisconsin Sedimentation Test. The container for this test holds about one pint of milk. A screw cap fits over the top. By means of a small air pump, pressure can be applied and the milk forced through a disk or filter. This disk is removable and the filtered-out dirt on the surface can thus be shown.

Necessity of Good Milk.—All authorities agree that the best grade of butter and cheese cannot be made from sour or tainted milk. The two countries renowned for the excellence of their

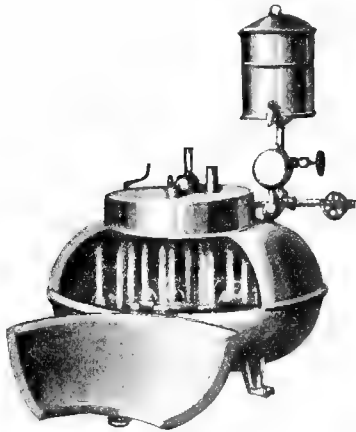

FIG. 32.—Wizard tester.

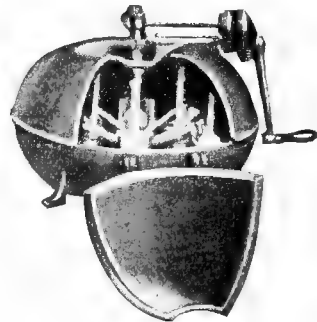

FIG. 33.—Twentieth-century hand tester.

dairy products—Denmark and Canada—owe their success largely to the purity of the milk from which these products are made. Makers who have won for themselves national reputations in cheese- and butter-making have almost invariably been men who insisted on getting first-class milk. The method of classifying milk and cream and paying for each according to quality has been adopted by some creameries.

The authors do not hesitate to say that cream whose flavor is such as to show that it is in a putrefactive or decomposed condition should be rejected as unfit for making an article of human food. While it is advocated by some that it should be

received, made into butter and sold on its merits, the wisdom of this is to be questioned. Cream that is simply off in flavor is a different proposition. This may, in justice and fairness, be taken in on its merits and paid for accordingly. The practice of receiving and paying for cream indiscriminately is something which should be condemned and discouraged. The authors have come in contact with many patrons in different parts of the country and have yet to meet the first patron who would seriously object to taking his milk or cream home when thoroughly convinced that its condition was such that it should not be received. Patrons, as a rule, respect the maker who keeps his creamery in a good sanitary condition and insists upon being supplied with a good quality of milk or cream. It should be the aim of every creameryman to make the highest grade of butter possible, and thus be in a position to take full advantage of a discriminating market, for this is the kind of market that pays the highest prices.

Sampling of Milk.—The sampling of milk and cream for fat tests is one of the most delicate problems with which the creamery operator has to deal. If a proper sample is not obtained, the ultimate test will not be correct, no matter how carefully the succeeding steps may be carried out. There are two methods of sampling in use: First, sampling with a small dipper, and second, sampling with a sample-tube, or milk-thief. The sampling of milk for composite samples should be done every day, and the samples taken should represent the average quality and form a certain proportionate part of the milk or cream delivered.

In order to get a sample which represents the average quality, the milk or cream delivered must be thoroughly stirred, so as to get an even distribution of the fat.

In order to get a proportionate part of the milk or cream delivered from day to day, it is necessary to use a sampling-tube.

The sampling of milk and cream with a dipper for composite samples has been in use for a long time, and is still practiced to quite an extent. However, it is fast becoming recognized that

the use of a suitable sampling tube is much better. It takes a more representative sample of a can of cream, whether it be for the making up of a composite sample or for the testing of an individual shipment. In the case of composite samples of both milk and cream it takes an aliquot portion, or one in proportion to the quantity of milk or cream delivered. The difficulty at one time in sampling cream—and particularly thick cream—with the sampling tube was that the only opening in the tube was at the bottom, and the cream would not flow into it as the tube was lowered. However, this trouble is completely overcome when a sampler like the McKay sampler is used. This is made up of two tubes, an inner and an outer, and a plunger (see cut). Both the tubes have openings up the side. Before inserting the sampler in a can of cream, the outer tube is turned on the inner so that the openings are not opposite each other, or so as to close the sampler, and the plunger is drawn back. The sampler is then lowered into the cream to the bottom of the can, when it is opened momentarily to allow it to fill and is then closed again. In emptying the sampler the outer tube, which is the shorter of the two, is drawn up a little to leave an opening at the bottom, and the plunger is pushed down to force the cream out of the tube. In doing so it cleans the tube completely. This style of sampler does equally efficient work whether used in a creamery or cream station, or in taking samples on a cream route.

An investigation made by the American Association of Creamery Butter Manufacturers showed the dipper method of sampling cream to be unreliable. In this investigation the cream in the can was first hand-stirred—no less than forty vigorous double strokes being used—and then sampled with a dipper, after which a sample was taken by means of a McKay or tube sampler. In all, thirty-two lots of cream were sampled and tested in this way, and the following short table gives some of the results secured:

Sample No.	Times Stirred	Condition of Cream	Babcock Test of		Difference
			Dipper Sample	Tube Sample	
					Per Cent
1	50	Viscous, not very smooth.	41.0	44.0	3.0
2	40	Smooth and even.	39.0	39.5	0.5
3	65	Heavy on top, liquid below, lumpy	42.5	38.5	4.0
4	60	Viscous but good condition.	34.5	33.5	1.0
5	44	Quite liquid.	26.5	24.5	2.0
6	60	Viscous, slightly lumpy.	40.5	40.5	0.0
7	75	Top fair, bottom almost solid, lumpy.	47.5	38.5	9.0
8	50	Good condition.	40.5	39.5	1.0

While the difference in the test of the samples under the two methods was usually not great, yet the dipper method of sampling proved unreliable.

Sampling-tube.—At creameries where milk is received, the sampling-tube, or milk-thief, gives the best results and satisfaction. It is very difficult in practice to get a proportionate sample with a dipper, from day to day. To illustrate: A patron who delivers 200 pounds of milk testing 3 per cent fat one day may on another day deliver 100 pounds of milk testing 5 per cent fat. If a dipperful is taken from each for a composite sample, the test of that composite sample will be $3+5\div 2$, or 4 per cent. According to this test, these 300 pounds of milk delivered will contain 12 pounds of butter-fat. In reality 6 pounds of fat were delivered in the 200 pounds, and 5 pounds of fat in the 100 pounds, making a total of 11 pounds of fat. Thus we see that the dipper method is not reliable, and in this case the patron was paid for 1 pound of butter-fat too much for the two days' delivery. If the sample taken from the 200 pounds of milk had been twice as great as that taken from the 100 pounds of milk, then the composite test would have been perfect, no matter whether it had been taken with a dipper or with a sampling-tube. If the same weighing-can is used every day, it is possible to maintain an

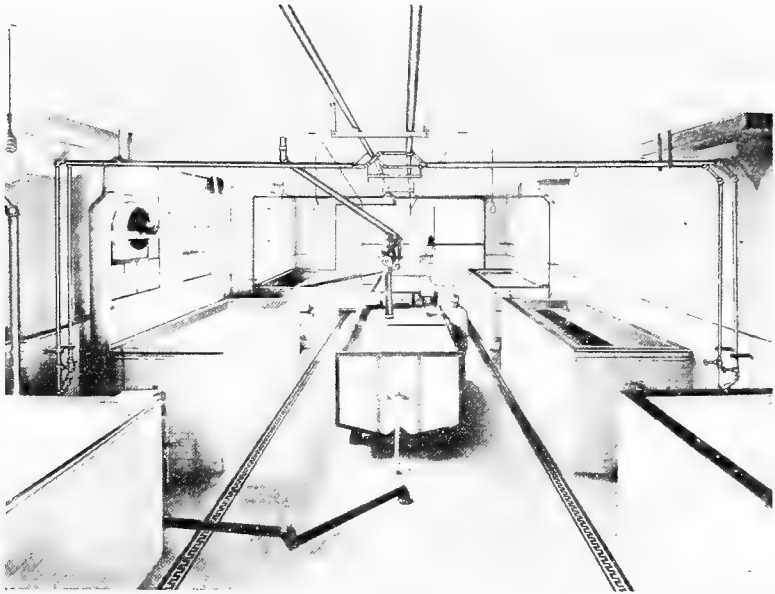

FIG. 34.—Vat room. Kirschbraun & Son, Omaha, Neb. One of the largest and finest creameries in the world.



FIG. 35.—Interior of creamery. Strawberry Point, Iowa. One of the largest whole-milk creameries in the U. S.

exact proportion for a sample by always putting the sampling-tube perpendicularly into the milk at the same place in the weighing-can, and by exercising care in other respects.

When the cream is being collected from different patrons by a hauler, a milk-thief often works unsatisfactorily. This is especially true during cold weather. A cream tube similar to the one shown in the accompanying illustration is more effective.

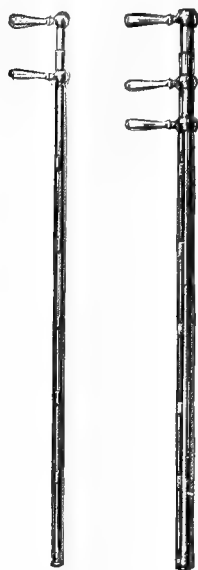

FIG. 36.—The McKay cream and milk sampler.

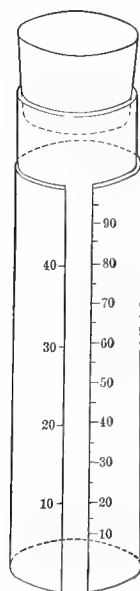

FIG. 37.—Cream sampling-tube.

The way in which the tube is used is apparent from the figure. If a certain patron has 40 pounds of cream, the cream is filled to the 40 mark on the scale of the tube; if he has 30 pounds, it is filled to the 30 mark, etc.

Sampling Churned Milk.—It occasionally happens that the milk arrives at the creamery slightly churned. This is especially the case during the summer. Usually such milk is sampled in this condition, but if it is desired to find the percentage of fat in such milk in its unchurned condition, it is essential to melt

the churned fat before sampling. If the butter has been churned into a few large lumps, these lumps can be taken out in a pan, or pail, with a comparatively small amount of milk, and this heated until the butter has melted. This is then remixed with the milk from which it was first taken and sampled while it is being stirred.

The churning of the milk during transit is mainly due to two things: First, to a high temperature of the milk (65° to 85° F.) and second, to hauling partly filled cans a long distance over rough roads. If the temperature of the milk is low (about 50° F.), when it leaves the producer, there is seldom any danger of having churned milk at the creamery.

Frozen Milk.—When milk is cooled to 31° F., or below, it freezes. Ice forms near the sides and bottom of the can, until a funnel-shaped cavity filled with milk is left in the center. According to both Richmond and Fleischmann, the icy portion contains more water than the unfrozen milk, and the unfrozen portion is rich in solids. According to Farrington, when 25 per cent of the sample of milk was frozen, the icy portion contained about 1 per cent less fat than the original portion. When about half of it was frozen there was no great difference in the fat-content of the frozen and unfrozen parts.

In practice, however, freezing seems to have a different effect. When a can full of partly frozen milk is sampled at the creamery, the unfrozen milk nearly always contains less fat than the original sample. This can be accounted for by opening the can of milk and noting the amount of frozen cream on the sides near the top. Whether the unfrozen portion contains less or more fat than the original depends, therefore, upon conditions. At any rate, frozen milk has a composition different from that of the original sample. On this account an accurate sample cannot be had, unless the frozen portion be first completely melted and well mixed with the remainder.

Sour and Coagulated Milk.—In order to get a fair sample from a can of sour and coagulated milk, it must be stirred very thoroughly, so as to bring the coagulated milk into a uniform emulsion. A better sample can usually be obtained

with a dipper. If the milk is not too thick, a fair sample can be obtained by the use of the sampling-tube. In order to reduce a can of coagulated milk to a thoroughly uniform quality, it is best to pour it from one can into another. This mixes it much more completely than if the sample were simply stirred with a dipper or any other kind of an agitator.

Apportioning Skim-milk.—The amount of skim-milk to be

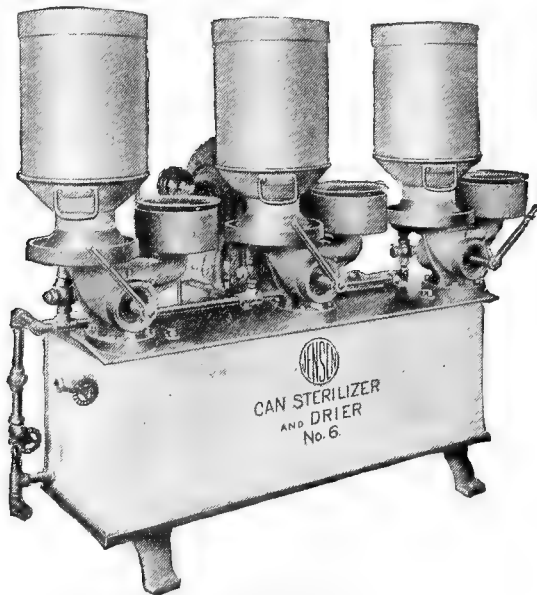

FIG. 38.—Jensen can drier, sterilizer and rinser.
(Jensen Creamery Machinery Co.)

received by the patron depends largely upon the thickness of cream skimmed, and upon the amount of skim-milk retained at the creamery for various purposes. The amount of skim-milk generally returned by creameries varies between 80 and 90 per cent of the whole milk delivered.

Most up-to-date creameries now make use of skim-milk weighers. Where such are employed, the man who receives the milk hands each patron a check for the amount of milk delivered. This check is put into the skim-milk weigher, and it allows an

amount of skim-milk to flow out, corresponding to the number of pounds indicated on the check.

In case a skim-milk weigher is not employed, it is essential

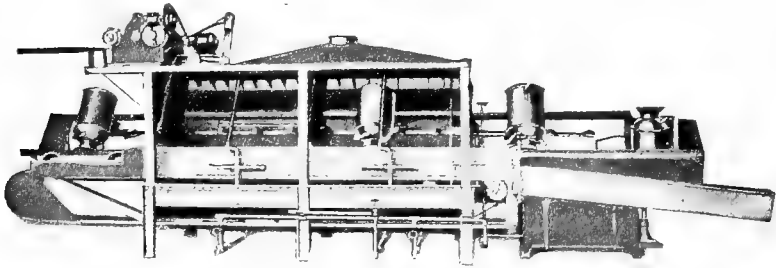

FIG. 39.—Hydraulic can washer and dryer (Creamery Package Mfg. Co.)

to have a man at the skim-milk tank to weigh out the proper amount of skim-milk to each patron. If the patrons are allowed to weigh out their own skim-milk, mistakes are frequently made, which result in more or less dissatisfaction. It is quite customary for butter-makers to draw a chalk line on the outside of the can some distance below the surface of the milk. This indicates the point to which the can may be filled with skim-milk.

Washing Cans.—

The creamery operator should make it a point to have all empty cans thoroughly washed with warm water, and then steamed and sterilized,

after which hot air should be blown through thoroughly to dry the cans. Frequently, bad flavors are transmitted to cream from cans that have been closed up tight before being thoroughly

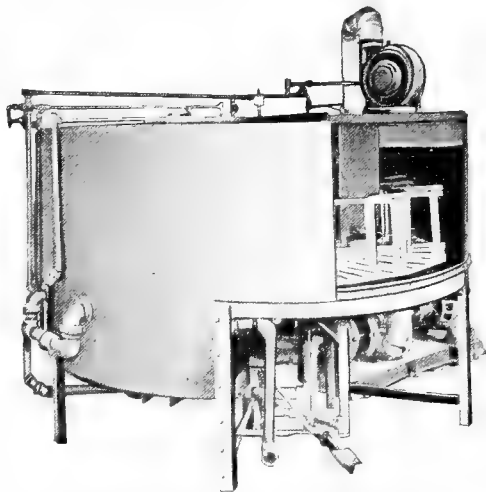

FIG. 40.—Hydraulic can washer—rotary type.
(Rice and Adams.)

dried. Where hot air is not used, the cans can be turned upside-down on a platform with openings to allow air to circulate through the cans, drying them thoroughly before the covers are put on.

Drying cans as above described not only conserves the tin of the cans, but also places the cans with the patrons in a clean condition, free from bad odors. It also saves considerable work on the part of the patrons, as well as insuring them a clean, sanitary can.

One patron told the author that this cleaning of the can was worth one cent per pound of butter-fat to him. The creamery is equipped to do this can-cleansing better than is the patron and it is repaid for this extra labor in a better grade of cream and in increased patronage.

CHAPTER IX

COMPOSITE SAMPLES

Definition.—In order to avoid testing each patron's milk or cream every day for fat, a small sample, which represents the average quality and a proportionate part of the whole, is taken from each patron's milk every day and placed in a jar. A preservative of some kind is previously placed in the jar to keep the contents from spoiling. This is called a composite sample.

When to Sample.—Some makers prefer to sample the milk or cream delivered every day; others prefer to sample every other day. Some creamery operators, again, sample four or five times in succession at intervals, the patrons being unaware of the time when the sampling is to take place. The most reliable and practical method, however, is to take a sample every day, and test it for fat at the end of every two weeks. When cream is received composite samples do not give reliable results. In fact this system has been very generally superseded by that of weighing and testing the cream of each delivery or shipment.

Kind of Preservatives to Add. While there are several preservatives that may be used, such as salicylic acid, borax, boracic acid, and bicarbonate of soda, those most commonly used are bichromate of potash and corrosive sublimate (mercuric chloride) either singly or as a mixture. Bichromate of potash, while poisonous, is not extremely so and it imparts a color to the sample which readily indicates its presence. It has, however, two defects; if used in excess it is very much inclined to cause a charred or burnt reading when the sample is tested, and if the sample be exposed to light for any length of time a leathery scum forms on the surface, which it is difficult to dissolve completely by means of the sulphuric acid.

Corrosive sublimate is a strong and a very satisfactory preservative; but it is quite poisonous, and where the powder itself, which is white, is used in composite samples some kind of coloring matter should always be added to indicate its presence.

According to the authors' experience, corrosive sublimate tablets can be highly recommended. The tablets contain a color, which, when dissolved, colors milk, so that it can readily be distinguished as not being fit for human food. The tablets are

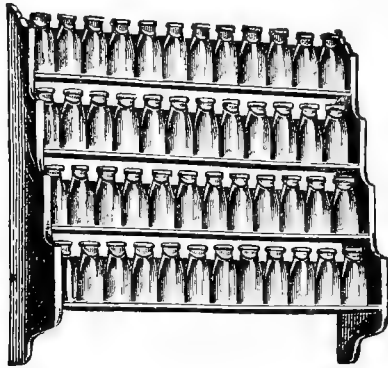

FIG. 41.—Composite samples and rack to hold sample jars.

very poisonous, but are more efficient in their preservative effect than bichromate of potash. They can be obtained from any creamery-supply house.

During the winter, when the samples are kept comparatively cold, less preservative is needed than in the summer. One corrosive sublimate tablet will keep a half-pint to a pint of milk

or cream in good condition for about two weeks in summer, and about three weeks in winter, providing the sample is properly cared for. Some makers are practicing testing at the end of every month during the winter, and every two weeks during the summer. Testing at the end of every month saves labor, but it is not a reliable method to follow under all conditions, as some of the samples are likely to be somewhat impaired after standing so long.

Arrangement of Composite Samples.—Pint glass jars with covers are, so far as known, the most convenient vessels to use for composite samples. Shelves should be arranged in the weighing-room on which to keep the bottles. If possible, it is best to have them in a case closed with glass sliding doors. This is neat, and, if the glass doors fit well, the samples are in some measure protected in case of quick, unexpected changes in temperature. These sliding doors should be locked when the cream-

ery operator is absent from the creamery, in order to prevent any tampering with the composite samples.

The best method of arranging the sample jars is to have all the jars belonging to the patrons of each route standing in one group, or on one shelf, if possible. The bottles are numbered to correspond with the number given each patron on the milk sheet. The name of the hauler, or the number of the route can be put on each shelf. The samples belonging to those who haul their own milk can be put on another shelf; these can be designated as individual haulers. Such a classification, when the bottles are plainly numbered, will often prevent the mistakes that are likely to occur if the bottles are simply numbered and put into a rack together.

Care of Composite Samples.—In the first place, the jars should be kept scrupulously clean. The tests are unreliable if the jars are left covered with milk and molds round the neck from one month to another. When the samples have been tested the jars should be thoroughly cleaned, and, if necessary, scalded, before they are used again. Care should be taken to spill as little milk as possible around the neck, inside as well as outside of the bottle, when the sample is put in. If the milk is spilled there, it gives the bottle an unattractive appearance. Very often it becomes moldy, and, as more milk is added and the sample shaken every day, this mold gradually extends down the sides of the bottle. This causes the composite sample to be infested with undesirable growth, and to spoil sooner than it would if greater care were taken in keeping the milk from coming in contact with the sides of the bottle before coming in contact with the preservative.

A few drops—but only a few—of formaldehyde added to the sample, where this is necessary, is a good preventive of mold; but this should not be used as a substitute for thorough cleaning of the bottles after each test period.

It is important also that the sample jars be well covered; otherwise the moisture evaporates, causing the milk or cream to dry up, and, making the test unreliable by increasing the per cent of butter-fat. A gentle rotary motion should be given each

jar when a sample is added to it to mix the cream, which rises to some extent after the milk has stood a while.

Average Sample.—It is sometimes desirable to obtain an average test of the milk from a whole day's delivery. This can be obtained in two ways: First, by taking a sample from each patron's milk with a sampling-tube, and putting all the samples together in one jar. The result represents an average test, providing the samples have been correctly taken. Second an average test can be had by boring a small hole in the conductor-head. When the milk passes over this hole, a small portion of it drops through. A vessel of some kind can be put underneath to catch the drops. Such a drip-sample will represent very accurately the average quality of the milk received at the creamery. If it is desirable to keep this sample, a preservative can be added to it.

Composite Sampling without the Use of Preservatives.—Pipettes can be obtained holding 5.87 c.c. of milk. These are one-third the size of the ordinary 17.6 c.c. pipette used for the Babcock test. With this small pipette a sample may be taken every day from each patron's milk, during three successive days, and emptied into the same test-bottle each day. At the end of three days the samples may be tested and the bottles cleaned, ready for use again.

Accurate composite samples may be obtained in this way, providing the sample in the pipette is correctly taken each day. No preservative is needed. The preservatives are added to the composite samples to prevent curdling. The test-bottles may be placed on a shelf, or preferably in a rack made to hold them. They should be marked in such a way as to identify them. A good way is to mark them as the composite jars are marked, the number on the test-bottle corresponding to the number on the milk-sheet for each patron.

CHAPTER X

CREAMERY CALCULATION

Find the Average Per Cent of Fat.—In calculating the average per cent of fat from a number of cows, or the milk furnished by the different patrons, the mistake of adding the tests of all the samples together and dividing the sum by the total number of samples tested is often made. Milk from different patrons, or from different cows, will always vary, both in quality and in quantity, and in order to get a correct average test, both quantity and quality must be taken into consideration. The wrong way of calculating the average percentage may be illustrated as follows:

Sample	Milk Delivered	Per Cent Fat
1	50 lbs.	5.0
2	100	4.5
3	500	3.0
4	300	3.5
		—
		4)166
		—
		4

The average test, according to the wrong method = 4 per cent.

The correct way of calculating the average percentage may be illustrated as follows:

The average test, according to the correct method, is 3.42 per cent.

It will be seen from the example quoted that there is a difference of more than .5 per cent. If the percentage of fat or the

Sample	Milk Delivered	Per Cent Fat
1	50 lbs.	5.0 = 2.5 lbs. fat
2	100	4.5 = 4.5
3	500	3.0 = 15.0
4	300	3.5 = 10.5
	950 lbs.	950)32.5 lbs. fat
		3.42

number of pounds of milk is uniform, it does not matter which of the two ways illustrated above is used. But as uniformity



FIG. 42.—A Russian co-operative creamery in Siberia.
(U. S. Government Bulletin.)

in either of these respects scarcely ever exists in practice, the only correct way of calculating the percentage is to find the total number of pounds of fat and divide it by the total number of pounds of milk; the result is .0342, which may be written 3.42 per cent.

It is very common for creamery patrons to test the milk from each of their cows, then add the tests together and divide by the total number of cows tested. The result they will call the average test, and frequently such tests are made use of as evidence against a creamery operator to prove that his tests at the creamery were not correct. The fallacy is evident from what has been said above.

The same mistake is also likely to be made in finding the average test from several creamery-plants and skimming-stations.

Calculation of Overrun.—The amount of overrun is the difference between the amount of pure butter-fat and the amount of butter manufactured from that given amount of fat. This difference, divided by the amount of fat and multiplied by 100 will give the percentage of overrun. The calculation of the overrun in the creamery should always be made from the fat-basis on which the patrons are being paid. If the fat is delivered in the cream, the overrun should be calculated from the fat in the cream. The overrun calculated from the composition of the butter manufactured would not be an indication of the correct overrun, as there might be serious losses of fat sustained during the different steps in the manufacture, such as from inefficient skimming, incomplete churning, and general losses in the creamery. It is possible that butter might show a high content of the substances not fat, and yet not show a good overrun on account of losses; while butter containing only a medium high moisture-content might show as great or greater overrun on account of thorough and efficient work during the different steps of manufacture.

The amount of overrun depends upon:

1. Thoroughness of skimming.
2. Completeness of churning.
3. General losses in the creamery.
4. Composition of the butter manufactured.

The theoretical overrun, however, may be quite accurately calculated from the composition of the butter manufactured in a well-regulated creamery. In creameries where the conditions of separation and churning are almost perfect, the amount

of fat lost in the buttermilk and the skim-milk is quite constant from day to day, and should not exceed .1 per cent in the skim-milk and .2 per cent in the buttermilk, according to the Babcock test. Basing the calculations upon the above figures, the theoretical overrun may be calculated from the composition of the butter as follows:

If, for instance, we start with 1000 pounds of milk testing 4 per cent fat, there will be a total of 40 pounds of fat. If we skim 32 per cent cream from 4 per cent milk, we should have $\frac{4}{32}$, or $\frac{1}{8}$ of it cream, and the remainder skim-milk, or 125 pounds of cream and 875 pounds of skim-milk. If there were .1 per cent of fat in the skim-milk, there would be a loss of .875 pound of fat during skimming. There would then be 39.125 pounds of fat in the 125 pounds of cream ($40 - .875 = 39.125$). If 10 per cent of starter were added to the cream we should get 137.5 pounds of cream testing 28.4 per cent. ($125 \text{ pounds cream} \times 1.10 = 137.5 \text{ pounds cream}$; $39.125 \div 137.5 \times 100 = 28.4 \text{ per cent fat}$.) By churning this cream we should obtain about 100 pounds of buttermilk. If it tested .2 per cent fat there would be a loss of about .2 pound of fat, making a total loss of fat in skim-milk and buttermilk of 1.075 pounds. Subtracting this total loss of 1.075 from 40 pounds we would have 38.925 pounds of fat left to be made into butter ($40 - 1.075 = 38.925 \text{ pounds of fat}$). If the butter on analysis proves to contain 82 per cent fat, the total number of pounds manufactured will be $38.925 \div .82 = 47.47$ pounds of butter. $47.47 - 40 = 7.47$ pounds theoretical overrun, and $7.47 \div 40 \times 100 = 18.7$ per cent overrun (theoretical).

It is evident that the losses of fat will vary according to the different conditions. The richer the cream, and the less fat in the whole milk to be skimmed, the more skim-milk there will be; the thinner the cream and the more fat there is in the milk to be skimmed, the less skim-milk there will be, and consequently with the same skimming efficiency less fat will be lost in the skim-milk. The thinner the cream is the more buttermilk there will be. These conditions must be left for the operator to govern according to the conditions present.

The actual amount and per cent of overrun as determined

in creameries is calculated as described previously. The formula is as follows:

$$\frac{\text{Butter} - \text{fat}}{\text{fat}} \times 100 = \text{per cent of actual overrun.}$$

Calculation of Churn-yield.—Instead of expressing the increase of butter over that of fat in the percentage overrun, as above, it is often customary among creamerymen to speak of the "churn-yield." For instance, they say that their test was 3.90, and their churn-yield was 5, meaning that on the average each 100 pounds of milk contained 3.9 pounds of fat and yielded 5 pounds of butter. The churn-yield is always expressed in percentage, and is obtained by dividing the total pounds of butter obtained by the total pounds of milk from which the butter was made, according to the following formula:

$$\frac{\text{Pounds of butter}}{\text{Pounds of milk}} \times 100 = \text{churn-yield.}$$

In case cream is handled instead of milk, the same may be obtained by substituting "pounds of cream" for "pounds of milk" in the formula.

What Should the Overrun in a Creamery Be? -In discussing this problem we shall take 80 per cent as the legal standard for fat in butter. If every churning of butter were to drop to this standard, but none below it—a thing quite impossible of attainment—if the patrons were credited with all the fat the creamery received, and if there were no mechanical losses, and no fat in the buttermilk, then every 80 pounds of milk-fat received would make 100 pounds of butter; that is, 100 pounds of fat would make 125 pounds of butter, or, the overrun would be 25 per cent.

The creamery has some gains and some losses which tend to offset each other.

The gains come mainly from two sources, namely, (1) a small fraction of a pound of cream on some, but not all, of the cans of cream. (2) A small fraction of a per cent of fat on some, but not all, of the cream tested.

In weighing cream half-pounds should be credited, and in the Babcock test of the cream readings should be made by half and not whole per cents, thus 30.0 per cent, 30.5 per cent, 31.0 per cent, etc., and not 30.0 per cent, 31.0 per cent, etc.

Following out this principle, the average gain in weight, per can of cream, will not exceed a quarter of a pound, and the average gain in per cent of fat will not exceed 0.25 per cent.

The losses may be enumerated as follows:

(1) *The Loss of Fat in the Buttermilk.*—This will, under present conditions, easily equal 0.5 per cent. Our extensive investigation of the losses of fat in buttermilk, including complete records of several hundred churnings in different creameries, shows this to be a very conservative estimate; and tests of hundreds of samples of buttermilk in the laboratory of the American Association of Creamery Butter Manufacturers fully support this estimate.

(2) *Losses in Packing.*—Enough butter must be put into a package to insure its having the proper weight when it reaches the market.

(3) Mechanical losses, due to cream adhering, to a small extent, to the different utensils—cans, vats, etc. Under this head may be included the occasional spilling of small quantities of cream.

(4) If practically all of the butter is to come up to the standard of 80 per cent fat, the average per cent of fat in the butter will exceed this a little.

(5) If the results of the investigation made by Siegmund and Craig, are to be accepted as correct, the Babcock test of cream, as ordinarily conducted, gives a reading that is a little high. Their findings are summarized in the chapter on “Receiving, Sampling, Grading and Testing.”

As a basis for estimating what the overrun in a well-conducted creamery should be, an 8-gallon can of cream will be taken as an average shipment and it will be assumed that the creamery, in weighing and testing the cream, credits the patron with 65.0 pounds of cream testing 30.0 per cent, whereas the actual weight of the cream is 65.25 pounds, and the actual test of the cream is 30.25 per cent. It will also be assumed that in a tub of butter

marked 62 pounds, net, there are actually 62.5 pounds of butter to allow for shrinkage.

Amount of fat credited to patron, 30 per cent of 65 lbs.	= 19.50 lbs.
Actual amount of fat in cream, 30.25 per cent of 65.25 lbs.	= 19.738
Weight of buttermilk, 70 per cent of 65 lbs.	= 45.5
Per cent of fat in buttermilk, 0.5 per cent	
Weight of fat in buttermilk, 0.5 per cent of 45.5 lbs.	= .227 lb.
Weight of fat in butter, 19.738 - .227	= 19.511 lbs.
Weight of butter made, on basis of 80 per cent fat, $\frac{100}{80} \times 19.511$	= 24.39
Weight of butter sold, $\frac{62}{62.5} \times 24.39$	= 24.2
Overrun $\frac{24.2 - 19.5}{19.5} \times 100$	= 24.1%

In the above calculation no account has been taken either of the mechanical losses or of the fact that the average per cent of fat in the butter will, of necessity, slightly exceed the minimum standard of 80 per cent.

In conclusion, then, we would say that while the overrun may, and will, vary to some extent, from day to day and from week to week, the creamery that does careful weighing and testing, and credits its patrons with half-pounds of cream and half per cents of fat, will be likely to have an overrun for the year of about 23 to 24 per cent. If it has this it is doing careful, efficient work. On the other hand, if the overrun is much above or below this something is wrong somewhere and needs to be remedied.

Calculation of Dividends.—The method of calculating dividends will vary according to the agreements between the manufacturer of the butter and the milk and cream producers. Some manufacturers agree to make the butter for so many cents per pound of butter (usually 3 or 4 cents). Occasionally the creamery proprietor agrees to pay a final fixed sum for milk delivered containing a definite amount of fat (usually 4 per cent). These two methods are not in use much at the present time, although in the eastern part of the United States the method of paying the operator so much per pound of butter-fat manufactured is quite common.

The two methods most commonly used, especially in the central West, are as follows:

(1) Pay so much per pound of butter-fat based upon some standard market price, such as Chicago or New York. The amount paid now by the central plants for butter-fat is usually 2 or 3 cents per pound below "New York Extras," and the company pays all freight or express charges.

(2) Pay per pound of fat based upon the net income of the creamery.

1. The former method of paying for butter-fat has become quite common. Nearly all the hand-separator or central plants are paying for butter according to this method. Payments are usually made at each delivery or every two weeks. Although this causes more work, it is much more satisfactory to the patrons than to pay only at the end of each month.

In order to calculate dividends when paid at the end of two weeks or at the end of each month, the first step is to find how many pounds of butter-fat have been delivered by each patron. If composite samples are taken, and these tested for fat at intervals of one week, which would make about four tests during the month, and two during half a month, the results of the several tests may be added, and the sum divided by the number of samples tested. This may give the average test, but it must be borne in mind that this method is also likely to give wrong results. Especially is this so when cream is delivered which varies in quantity as well as quality during the different parts of the month.

If cream only is being received, it is a good plan to test each patron's cream every day, as it is more or less difficult to get absolutely accurate composite samples from creams of different richness. Besides this, the patrons can get the test as well as the weight of the cream of each previous day's delivery, and thus know how their account stands from day to day. A little more labor is involved in doing this, but in the long run it keeps the patrons better satisfied.

2. If the price of butter-fat per pound is being based upon the net income, as is the case in nearly all co-operative creameries, and also in many proprietary creameries, the first step is to find out how much butter-fat each patron delivered during the specified time,—two weeks or a month, whichever may be the case.



FIG. 43.—Coos Bay Creamery, Oregon. All milk delivered by boat.

When this has been obtained, the total pounds of fat delivered by all the patrons are found. From the gross income the total expenses of running the creamery are subtracted. The remainder represents the net income. This is then divided by the total pounds of fat delivered to the creamery, and the quotient represents the price per pound of butter-fat to the patrons.

Knowing the price to be paid to the patrons for 1 pound of fat, the sum due to each patron is found by multiplying the price per pound by the total number of pounds of fat each patron delivered during the specified time.

In some instances provisions are made for a "sinking fund." This is a name given to a fund raised by deducting so much per pound of fat, or per 100 pounds of milk, from each patron's delivery at the end of each month. This fund is for the purpose of paying off a debt gradually, or for raising a fund for new equipment, or other improvements in the creamery. In case such money is to be withheld, it is deducted previous to making the final calculation.

Cream-raising Coefficient.—By the term cream-raising coefficient we understand the percentage of the fat removed from the milk during the process of separation. The calculation of the cream-raising coefficient may be illustrated as follows:

Suppose we have 100 pounds of milk containing 4 per cent fat, and yielding 85 pounds of skim-milk and 15 pounds of cream, the skim-milk containing .2 per cent fat.

$$\text{Total fat in whole milk} = 100 \text{ lbs.} \times 4 \text{ per cent} = 4 \text{ lbs.}$$

$$\text{Total fat in skim-milk} = 85 \text{ lbs.} \times .2 \text{ per cent} = .17 \text{ lb.}$$

$$\text{Total fat in cream} = 4 \text{ lbs.} - .17 \text{ lb.} = 3.83 \text{ lbs.}$$

$\frac{3.83 \times 100}{4} = 95.75$ per cent of the total 4 pounds of fat, or the cream raising coefficient.

Statement to Patrons.—A complete statement should be made at the time of each settlement and should be accompanied by the check. A statement similar to the following one may serve as an example:¹

¹ Creamery Butter-making by Michels.

_____ CREAMERY COMPANY
IN ACCOUNT WITH

Mr. _____

For the month of _____ 192_____

	Cr.	Dr.
No. pounds milk delivered		Pounds butter at
by you		Cans, at
Average test		Cash
No. pounds butter-fat		Hauling at per 100 lbs
Price per pound \$		\$

Balance due you		\$
Total pounds milk delivered at creamery		
Average test at creamery		
Total pounds butter-fat at creamery		
Sales of butter {	_____ lbs. at _____	\$
	_____ " _____	\$
	_____ " _____	\$
	_____ " _____	\$
Less _____ cts. for making.		
Balance due patrons		\$
Per cent overrun		
Testing witnessed by _____		
_____	<i>Presl.</i>	
_____	<i>Secy.</i>	

At the end of the year a final statement should be made by the respective officers, similar to the following one:

ANNUAL REPORT

Incorporated 192 Commenced Operations 192
Annual Report, 192
of the
_____ CREAMERY COMPANY
of _____, Iowa.
(_____ Butter-maker; _____ Asst. Butter-maker
CAPITAL STOCK, \$ PAID IN \$

OFFICERS AND DIRECTORS.

_____ *President,* _____ *Secretary,* _____ *Treasurer,*

SECRETARY'S REPORT

To the Stockholders: Your Secretary herewith submits the following report for the year ending December 31, 192...

Total pounds of milk received	
Total pounds butter-fat contained in same	
Total pounds butter manufactured	
Average test of butter-fat per hundred pounds of milk	
Average yield of butter per hundred pounds of milk	
Average price paid per hundred pounds of milk	
Average price paid per hundred pounds of butter-fat	
Average per cent increase of churn over test (overrun)	
Average price received per pound of butter	
Average monthly expenses of running creamery	
Average cost of manufacturing butter per pound	

Following is a Monthly Statement for the year 192..

January	
February	
March	
April	
May	
June	
July	
August	
September	
October	
November	
December	
Totals	

TREASURER'S REPORT.

To the Stockholders of the _____ Creamery Company: Your Treasurer herewith submits the following report:

STATEMENT OF CASH RECEIVED AND DISBURSED

	RECEIPTS	DISBURSEMENTS
Total		Total

Respectfully submitted, _____, Treasurer.

_____ Cashier of Bank.

STATEMENT OF CASH RECEIVED AND DISBURSED

RECEIPTS.	DISBURSEMENTS.
Received for butter . . . \$.....	Paid to patrons for milk . . \$.....
	Running expenses of creamery and supplies on hand . . .
	Paid for machinery, material, repairs, etc. (out of percentage fund)
	Paid dividend on stock for 192 (out of percentage fund)
	Paid dividend on stock for 192 (out of percentage fund)
Total amount of cash received and paid to Treasurer	Total amount of orders drawn on Treasurer
Cash balance in hands of Treasurer, Jan. 192.	Cash balance in hands of Treasurer, Jan. 192.
Total	Total

REPORT OF AUDITING COMMITTEE.

To the Stockholders of the _____ Creamery Company:

We, the undersigned, appointed by your Board of Directors to examine and audit the Books, Accounts, and Vouchers of the Secretary and Treasurer of the _____ Creamery Company for the year 192. , hereby certify that we have carefully examined the same and compared them with the above reports of said officers, and find them correct.

In witness whereof we have hereunto set our hands at _____, Iowa this . . . day of A.D., 192

 _____, Auditing Committee.

Paying for Fat in Cream Compared with Paying for Fat in Milk.—It is evident that when patrons deliver fat in the form of milk the creamery operator sustains a loss in the skim-milk, while if the fat is delivered in the form of cream, no fat is lost in the skim-milk at the creamery, and consequently the cream patron should receive more per pound of fat delivered than the whole-milk patron provided the quality of the fat in the cream is as good as that in the form of milk. The butter-maker should obtain a larger overrun from the fat of the cream than he does from the fat of the milk. The amount which the patrons should

be paid for fat, delivered in the form of cream, depends upon the thoroughness of skimming. If 1000 pounds of milk testing 4 per cent fat were bought and skimmed, there would be a loss of about .9 of a pound of fat during the skimming, which would make about 1 pound of butter, worth about 30 cents. If bought in the form of cream this loss would not be sustained. The above loss during skimming, according to the figures mentioned, would amount to about three-quarters of a cent per pound of butter manufactured. The fat lost during the skimming process would amount to about 2 per cent of the total fat. If the cream fat be increased by 2 per cent, an approximate basis for paying milk and cream patrons is obtained.

This argument, however, will hold good only when the cream is graded and paid for on a strictly quality basis. This is decidedly the exception, not the rule, at the present time. Milk, however, is graded to a much larger extent. If it is seriously off in flavor it is likely to be rejected; furthermore, it has to be cooled promptly to prevent it from souring, and this holds fermentations in check. Everything considered, we are quite inclined to the view that the cream and milk patrons of a creamery should—under present conditions at least—be placed on a par as to the price paid them per pound of fat.

CHAPTER XI

HEATING MILK PREVIOUS TO SKIMMING

Reasons for Heating.—Owing to the fact that all separators will skim closer and not clog so easily when milk is heated, nearly all creameries heat or warm the milk previous to skimming. When the milk is thus heated and stirred in a pure atmosphere, many undesirable odors or taints escape. With an increase of temperature, the viscosity of the milk is lessened, due chiefly to the softening and separation of the fat-globules. Such an increased fluidity of the milk lessens the resistant force of the fat-globules when exposed to the centrifugal force of the separator. The higher the temperature the more fluid the milk becomes, and consequently the more easily the fat can be separated.

By warming the milk to a high temperature and leaving it for some time, then cooling quickly again to skimming temperature (90° F.) and separating, the skimming efficiency of the separator is increased materially. If the milk has been standing at a very low temperature for at least three hours, and then is quickly warmed up to the usual skimming temperature, and skimmed, the warming of the milk has comparatively little effect in bringing it into a good condition for skimming. It will thus be seen that it is possible to skim milk at the same temperature, and yet get different results, due to previous temperature conditions. Duration of temperature should be considered as well as the temperature itself.

The temperature to which milk should be heated previous to skimming varies according to different investigators. The temperature mostly employed in the past in this country, and perhaps at the present time, is about 90° F. This comparatively

low temperature was fixed owing to the supposedly bad effect high skimming temperatures had upon the body of the finished butter. Exposing milk at high temperatures to the centrifugal force in a separator was said to produce a greasy body in butter. According to experiments conducted at the Iowa Experiment Station by the authors, milk can be skimmed at 175° F. without any injury to the quality of the butter, providing the cream is cooled to ripening temperature, or below, as soon as it has been skimmed. After the ripening has been completed the cream should be exposed at least three hours to a low temperature (50° F.) previous to churning.

If the milk is heated in any of the best modern heaters, there will be no injurious results to the quality of the butter. Professor Dean, at the Ontario Agricultural College, has also found it practical to heat to pasteurization temperature previous to skimming. In many creameries in Denmark this method of heating milk is also followed. The Danes, as a rule, however, pass the heated milk over a cooler before it goes into the separator.

The chief difficulty encountered by the authors in heating milk to such a high temperature previous to skimming was that the upper bearing in the separator got so hot that it was deemed injurious to the separator, although the bearing did not heat to such an extent as to cause the running of the machine to be abnormal in any way.

Advantages of Warming Milk to High Temperature Previous to Skimming.—The advantages of heating milk to a high temperature (175° F.) previous to skimming may be summarized as follows:

(1) Undesirable taints are eliminated from the milk to a greater extent than can be accomplished in any other way, without applying chemicals.

(2) The heating of whole milk destroys the germs in the resultant skim-milk and cream practically as efficiently as when they are heated after the skimming process has been completed.

(3) Less heating and cooling apparatus is necessary.

(4) Closer skimming is possible.

How Heated.—There are two methods by which milk is heated previous to skimming. First, by the use of direct live steam; second, by the use of heaters which heat with steam or hot water indirectly.

Heating of milk with direct live steam is accomplished in two ways: first, by entering a steam hose into the vat full of milk; and, second, by making use of special heaters, which allow steam to come in direct contact with the milk as the milk passes through.

The method of heating milk with direct live steam cannot be too strongly condemned, because it has a bad effect upon the flavor of the butter. At the Milwaukee National Butter



FIG. 44.—The Twentieth-century milk-heater.

contest in 1903, where over eight hundred exhibitors were represented, the authors noticed that where the criticism "burnt," "oily flavor" was made on the score card, the milk from which the butter was made had in most cases been heated with live steam. The burnt flavor may possibly be due to the sudden excessive heat to which the milk will be exposed when coming in contact with live steam. The greatest danger, however, in heating milk with live steam is, that impurities from the pipes and boiler are likely to be transmitted to the milk, and cause bad flavors. In most of the creameries the exhaust-steam from the engine is used to heat the water for the boiler. This steam is likely to carry with it cylinder-oil, which will impart undesirable flavors to the butter. Some creameries are also using boiler compounds for the removal of scales. These,

when subjected to high heat and pressure, are likely to be transmitted to the steam-pipes, and from there with the steam into the milk. The scale and rust of steam-pipes are also likely to be transferred to the milk.

The right way to heat milk previous to skimming is to make use of one of the special heaters on the market, which heat by the use of steam or hot water indirectly.

CHAPTER XII

SEPARATION OF CREAM

IN the process of the manufacture of butter it is essential that the fat of the milk shall be concentrated into a comparatively small portion of the milk serum. This concentration of fat carries with it a portion of all the other milk constituents, and the product is called cream. It is possible to churn milk without any separation, but a much greater loss is attendant, if the fat is not brought together by the process called separation.

The different kinds of cream may be classified according to the different methods of cream-separating:

Cream	{	Gravity cream . . .	{	Shallow-pan cream.
			{	Deep-setting cream.
			{	Water dilution cream (hydraulic).
	{	Centrifugal cream	{	Hand-separator cream.
			{	Creamery-separator cream.

GRAVITY CREAMING

Shallow-pan System.—This method of creaming is used mostly on farms which are situated unfavorably in relation to a creamery, or for some other reasons do not send their milk to the creamery. It consists in placing the milk in shallow pans, from 2 to 4 inches in depth, as soon after milking as possible. The milk is then placed where it can be quickly cooled to a temperature of at least 60° F. A lower temperature than this is desirable if conditions permit. The atmosphere in the room in which the milk is standing must be pure, free from dust, draught, and any undesirable taints or odors, since it takes about thirty-six hours of quiet standing for the cream to rise. If there is a constant current of air in the room, a leathery

cream is likely to form. At the end of this time the cream is removed by the use of a skimmer, made especially for this purpose. It is difficult, however, to remove all the cream by this means. The perforated skimmer should never be used. It allows the thin under-layer of cream to run through and be lost in the skim-milk.

If the conditions are such that cool water can be constantly circulated around the pans containing the milk, the temperature can easily be made to go below 60° F., and the creaming process is facilitated. When such conditions are present, the depth of the milk in the pans can safely be increased to about 6 inches. Under the most favorable conditions about .5 per cent fat will remain in the skim-milk.

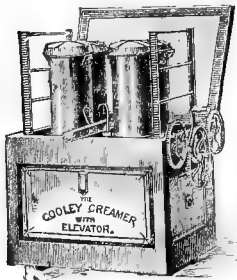

FIG. 45.—Cooley creamer and elevator.

Deep-setting System.—This system is undoubtedly the best method of gravity creaming. When it is properly carried on the fat can be removed so completely that no more than .2 per cent of fat remains in the skim-milk. It consists of putting milk into deep cans (ordinary four-gallon shotgun cans are

usually employed) immediately after the milk has been drawn from the cow. Then it is put into cold water, and generally cooled down to, and maintained at, a temperature of about 55° F. The cream will rise in about twenty-four hours. Better results can be obtained if the water is cooled down to about 40° with the use of ice.

One reason why this system is so much in use, even in creamery localities, is that the cream obtained is nearly always of a good quality. The farmer knows that unless the milk be cooled quickly, and maintained at a low temperature, the cream will not rise freely. For this reason the milk is systematically and thoroughly cooled, which is one of the great essentials in checking the growth of the ferments in milk and keeping the milk in good condition. In many parts of the eastern United States, the deep-setting system is in general use. A special form of can is used,

it is simply an ordinary four-gallon can, about 8 inches in diameter and 20 inches deep. It has a glass on one side near the bottom or near the top, which allows the reading of the thickness of the layer of cream. On each side of the glass is a graduated scale, which gives the reading in inches. In case the cream is being sold to a creamery, the hauler comes along, notes the depth of the layer of cream, and records the number of inches of cream opposite the patron's name. At the end of the month, or whenever the time for payment comes, the money is apportioned according to the number of inches of cream delivered by each of the patrons. No test for fat is made. This is what is known as the "Cooley system," and is used quite extensively in the East, especially in Massachusetts.

While cream usually arrives at the creamery in a fair condition, there is the objection that the cream is always thin. It seldom contains any more than 18 or 20 per cent of fat.

No good explanation has yet been given why cream in a deep layer of milk at 40° F. should rise more quickly and more completely than in a thin layer at a higher temperature. Arnold¹ seeks to explain it by saying: "Water is a better conductor of heat than fat; hence when the temperature of the milk varies either up or down, the water in the milk feels the effect of the heat or cold sooner than the fat in the cream does. Therefore the cream is always a little behind the water in swelling with heat or shrinking with cold, thus diminishing the difference between the specific gravity of the milk and cream when the temperature is rising, and increasing it when the temperature is falling."

This explanation is, according to Babcock,² not satisfactory. He says: "Though it is true that water is a better conductor of heat than fat, the small size of the fat-globules renders it impossible that under any circumstances there can be more than a small fraction of a degree of difference between the temperature of the fat and that of the milk serum. Moreover, with the limits of temperature practical for a creamery, (90° to 40° F.), the coefficient of expansion of butter-fat is more than three times as

¹ American Dairying, p. 210.

² Wisconsin Experiment Station, Bull. 18, p. 24.

great as that of water, so that in order to maintain the same relative difference in their specific gravities when the temperature is falling, the milk serum must cool nearly three times as quickly as the fat. In other words, when the milk serum has cooled from 90° to 40° , or 50° F., the fat-globules should have lost less than 17° , and should still have a temperature of over 70° F., a difference between the temperature of milk serum and fat of more than 33° . Such a condition is manifestly impossible, but a less difference than this would cause the fat to become relatively heavier than at first, and would operate against the creaming."

A low temperature increases the viscosity of the milk, and consequently it would seem that the resistant force of the fat-globules in their upward passage through the milk serum would be increased, and thus retard the creaming. Babcock maintains that fibrin is partially precipitated when milk is allowed to stand at a medium high temperature. The fibrin, when precipitated, forms a fine network of threads permeating the milk in all directions, similar to the network of fibrin in coagulated blood. It is possible to conceive that such a network would interfere with the rising of the fat-globules, at comparatively high temperatures. The reason that fat-globules will rise more quickly and more completely in the deep-setting system than in the shallow-pan system, might be explained on this fibrin theory were it not for the fact that experiments conducted at the Cornell Experiment Station show that the setting and cooling of milk may be delayed long enough for this fibrin to form, without any effect upon the separation when set and cooled.

Probable Explanation.—There are two factors which, taken in conjunction with each other, seem to offer a reasonable explanation of the efficiency of the deep-setting system.

The first of these is that cooling the milk to, and holding it at, a low temperature keeps the milk serum in a much better physical condition. It may not be so fluid as it would be at a higher temperature, but there is a minimum formation of fine masses or particles of curdy matter that would either imprison some of the fat or offer obstruction to the fat-globules, and

clusters of globules, in rising. It is a fair assumption that in the experiment at the Cornell Station the milk was not held long enough, before cooling, seriously to impair its physical condition.

The second very probable factor is that of the formation of fat clusters, through large fat-globules rising faster and coming into contact with smaller ones. These and other clusters would continue to pick up isolated globules and smaller clusters, and so the process would continue; clusters would, of course, rise more readily than individual globules, and larger clusters would rise more rapidly than smaller ones. The result would be that, owing to the good physical condition of the milk—the absence of casein particles to enmesh the fat-globules and offer obstruction—practically all the fat-globules would find their way to the top.

Water-dilution Cream (Hydraulic.)—It was thought, at one time, that a modification of the deep-setting system, through the dilution of the milk with water to the extent of 25 per cent to 50 per cent, would greatly add to its efficiency, through reducing the viscosity of the milk. The idea was, of course, commercialized and a number of so-called “dilution cream separators” were placed on the market. The method is still practiced to some extent, but it is by no means as general as it was at one time.

While it is true that under very exceptional conditions—such as in setting the milk of an occasional individual cow near the end of her lactation period—some advantage may be gained, the principle has no general application. It must be remembered that, while the addition of water to milk makes it more liquid, it also reduces the difference in specific gravity between the milk serum and the butter-fat, and it is upon this difference that we depend to bring about a separation.

Even though the skim-milk should, at times, show a lower per cent of fat, this is only an apparent advantage, as there is a much greater quantity of it. Wing¹ obtained the following results with diluted and undiluted milk:

¹ Milk and Its Products, p. 105.

Diluted with 25 per cent water, set at 60° F. (39 trials), 0.77 per cent fat in the skim-milk.

Undiluted, set at 60° F. (30 trials), 1.00 per cent fat in the skim milk.

Undiluted, set at 40° F. (30 trials), .29 per cent fat in the skim-milk.

A test of .77 per cent, where the milk is diluted to the extent of 25 per cent, means a greater loss of fat than where the skim-milk from undiluted milk tests 1.00 per cent.

It will be noted that, in his trials under the dilution method, Wing set the milk at 60°. The reason for this was that advocates of the system contended that it would bring about such a speedy, and yet complete, separation that it was unnecessary to adopt low temperatures. Wing's experiments prove two things; first, that whether milk is diluted or undiluted the loss of fat is heavy if the setting temperature is high, and, second, that where the milk, without dilution, is set at a low temperature the creaming coefficient is quite satisfactory.

The valid objections to the dilution method are as follows:

Much more bulk to handle, the use of a larger number of cans, and increased labor.

Danger of contamination of the milk and cream through the use of impure water.

Impairment of the value of the skim-milk for feeding.

Injury to the cream or butter—the product has an undesirable, flattish flavor.

The loss of fat in the skim-milk is too great, as the experiments by Wing show.

CENTRIFUGAL CREAMING

In the separation of cream by centrifugal machines, the same principle is used as in the gravity system of separation. The only difference is that in the centrifugal method the force which separates the cream from the milk is generated by artificial methods, and acts in a horizontal direction; in the gravity system the force which separates the cream from the milk is only that which results from the difference in the specific gravity of the

cream and the skim-milk, and the force acts in a vertical direction. The force generated in the separator is several thousand times greater than the natural force in the gravity method. For this reason the cream separates almost instantaneously after the milk has entered the separator and is exposed to the centrifugal force.

Advantages.—The centrifugal separator has several advantages over the gravity method, which are apparent without detailed elaboration. In the first place, the range of temperature and condition of the milk at which the cream can be successfully separated is much greater than that for successful separation by the gravity method. Second, a much better quality of cream can be obtained by the centrifugal system, as the separation can be done before the milk gets old, while by the gravity method the time required for efficient separation is so long that the cream deteriorates more or less before it is removed from the milk. Third, by the centrifugal method the thickness of the cream can be regulated to suit requirements, while by the gravity method the thickest cream that can be obtained is about 20 per cent. Fourth, by the centrifugal method many impurities and undesirable germs are removed, while in the gravity method the exposure to open air, more or less impure is likely to contaminate the milk with taints, and also allows the germs to fall into it. Fifth, by the centrifugal method the skim-milk is left in a more natural condition. The milk can be skimmed soon after milking, or after it has been delivered to the creamery, and thus be in the best possible condition for feeding purposes. Sixth, the centrifugal method permits of a more thorough separation of the fat. Butter-fat, as a rule, is too expensive to feed, when good and much cheaper substitutes can be had.

History of Centrifugal Separators.—The first centrifugal separator was a very simple one. It consisted of buckets hanging on the ends of arms, or on the periphery of a rotating horizontal flat wheel which swung on a central axis. The milk was placed in the buckets and whirled for a time, and then the machine (if we may call it such) was stopped, and the cream removed in the

same way as in the gravity system. This method of separation, according to J. H. Monrad,¹ had its origin in 1864. As early as 1859 Professor Fuchs of Carlsruhe, Germany, suggested testing the richness of milk by swinging tubes holding the samples of milk. In 1864 Prandtl, a brewer of Munich, separated milk by such a device. In 1870 Rev. F. H. Bond, of Northport, Massachusetts, worked out a method of separation which consisted of two small glass jars attached to a spindle making 200 revolutions per minute. By one hour's whirling the cream was brought to the top.

In 1875 Prandtl exhibited at Frankfort-on-the-Main a con-

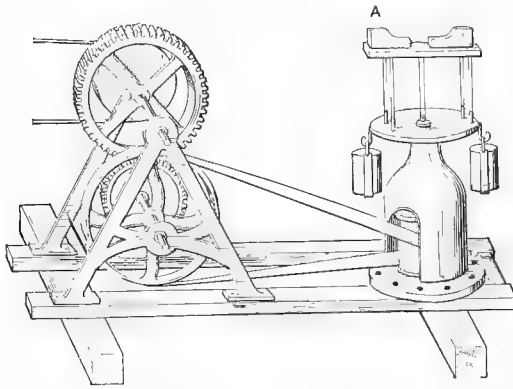

FIG. 46.—First centrifugal separator. (From Dairy Messenger.)

tinuous separator, which did not at the time attract much attention, due chiefly to the excessive amount of power needed to overcome the resistant force of the air. In 1876 a Danish engineer named Winstrup succeeded in improving the old bucket method. In 1877 Lefeldt and Lentch offered for sale four continuous separators with different capacities (from 110 to 600 pounds of milk per hour). During that year also, the first practical centrifugal creamery was established at Kiel, Germany. In 1877 Houston and Thompson of Philadelphia filed a patent for the continuous method of separation of cream from milk. The patent was allowed in 1891. In March, 1877, Lefeldt and Lentch

¹ Dairy Messenger, Oct., 1892, p. 109.

invented a separator similar in construction to the hollow bowl—a more recent type. This machine did not revolve at so rapid a rate as our modern machines do, nor did it have arrangements for continuous inflow and discharge. It was intermittent in its work, and it was necessary to stop at intervals to remove the cream and skim-milk. The year 1879 marked the greatest advancement toward the perfection of modern separators, in the appearance of the Danish Weston, invented in Denmark, and the De Laval, invented in Sweden during that year. This led to continuous milk and cream discharges, and consequently also to the continuous inflow of whole milk. These machines were of the hollow-bowl construction.

Modern Separators.—Since the year when the Danish Weston and the De Laval machines were invented, many different types of separators with different contrivances within the bowl have been put upon the market. Baron Bechtelsheim, of Munich, is given the credit of having discovered that certain contrivances on the inside of the machine increase the efficiency and capacity for skimming. This discovery was made, according to J. H. Monrad,¹ in 1890. This invention was bought by the De Laval Company.

The principal part of practically all the separators is a bowl rotating in a vertical position, with or without contrivances inside the bowl. Machines having a bowl rotating in a horizontal position are, so far as the authors know, not in use at the present time. Such a machine was once manufactured at Hamburg, Germany, and was called "Peterson's Centrifugal Machine." Another German machine, called "The Page," was also manufactured in the horizontal bowl style.

From the above it will be noticed that four separate steps are recognizable in the evolution and improvement of separators:

1. Revolving Bucket Centrifuge;
 2. Intermittent Hollow Bowl;
 3. Continuous Hollow Bowl;
 4. Continuous Separator with contrivances within the Bowl.
- The science and practice of separation of milk and cream have

¹ Dairy Messenger, Jan., 1892, p. 9.

seemingly reached a high state of efficiency. It seems almost improbable, considering the many new improved separators on the market, that any other great improvement could be made which would add a separate stage to the improvement of our best centrifugal milk separators of to-day.

Classification of Separators.—Owing to the many different

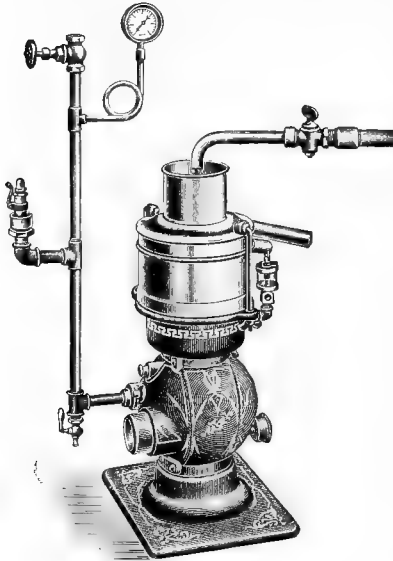

FIG. 47.—The Simplex separator.

standard types of separators now on the market, it is impossible to describe each one in detail. For this reason the classification appearing below has been made. There are undoubtedly many other types, especially in foreign countries, with which the writers are not familiar, and which are not mentioned here. The following classification will, in some measure, illustrate the different makes of separators on the market to-day:

Many of these separators which cause the milk to pass

up and down in vertical sheets have the bowl contrivances corrugated and perforated with holes so that the skim-milk and cream also assume a partly horizontal direction.

Process of Separation.—From the illustrations, the structure of the more common types of separator bowls is readily understood. The whole milk may be made to enter at the bottom or top of the bowl when revolving. In the Sharples, it enters at the bottom, the more common way is to have it enter at the top. As the milk enters the bowl and is exposed to the centrifugal force, it immediately begins to separate into three distinct layers. The centrifugal force acting in a horizontal direction forces the heaviest portions of the milk and the precipitated albuminoids, ash, filth, and a multitude of germs over next to the wall of the

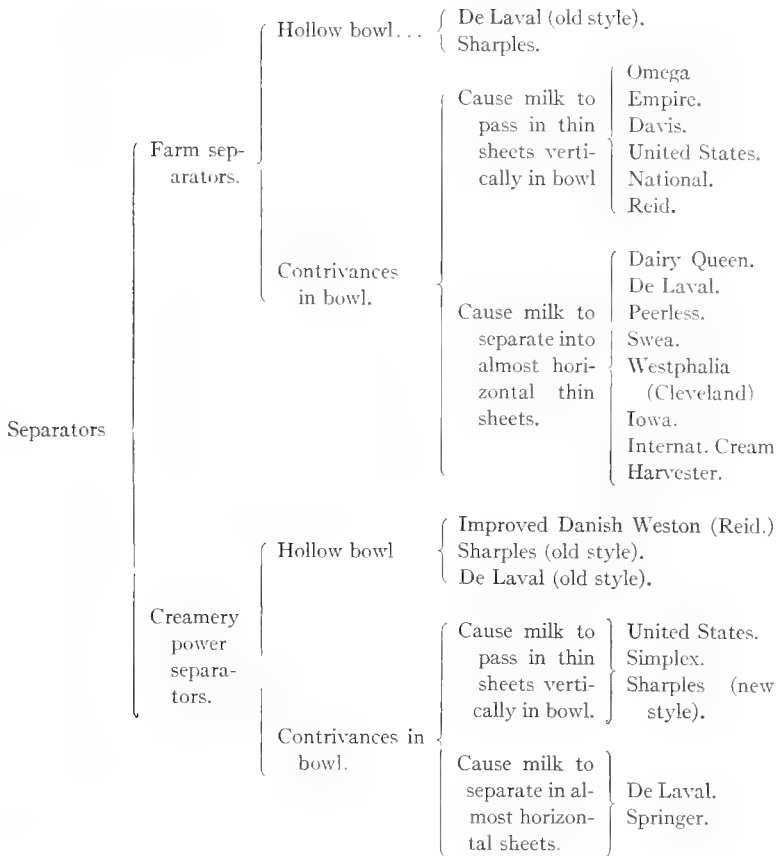

separator bowl, and into a solid and more or less gelatinous layer, which is known as the "separator slime." In very impure milk this substance is so plentiful that it is likely to clog the separator in a very short time, and before much separation is accomplished it is necessary to clean out the bowl. The second layer is the skim-milk, while the cream, being the lightest, is forced to the center of the bowl and forms the third portion mentioned. There is no distinct line of demarcation between the layers of skim-milk and cream. They overlap each other and form a sort of zone, rather than a sharp separation. The richest cream is nearest the center of the bowl, and gets thinner toward the outer portion of the bowl; consequently, by turning the outlet for the cream, or

cream screw, nearer the center of the bowl, the cream is increased in richness. Turning it away from the center causes the cream

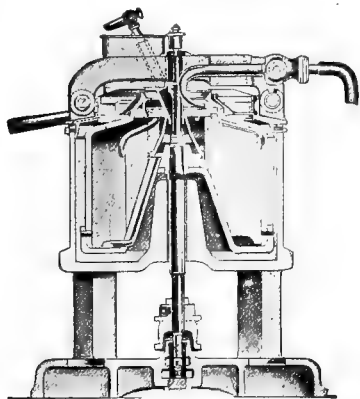

FIG. 48.—The Reid separator.

to be thinner. The skim-milk that is forced clear to the circumference of the bowl contains the least fat, and consequently the skim-milk is always first removed from this portion of the bowl. Usually the skim-milk outlet is brought in towards the center of the bowl at one end through tubes extending from the circumference of the bowl.

If this were not done, some difficulty would be involved in arranging a receiving-pan for the discharged skim-milk. If the skim-milk were discharged near the circumference of the bowl, it would come out with a heavy force.

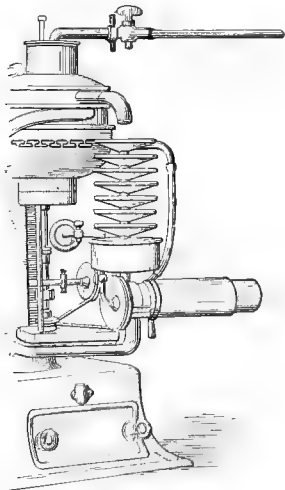

FIG. 49.—Showing "butter extractor" attached to De Laval separator. The butter extractor is not known to be in use now.

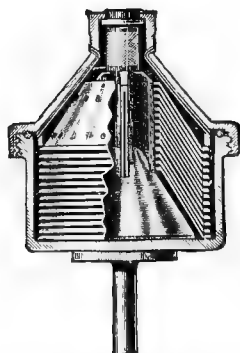

FIG. 50.—Showing cross-section of De Laval separator bowl.

Also, if the outlet for the skim-milk were near the circumference of the bowl a great deal more power would be required to run the machine. As the skim-milk passes through the tubes towards the center it gives up its force. The nearer the skim-milk outlet can be brought to the center of the bowl, the more easily will the machine run.

The size of the skim-milk outlet is usually such that it bears a certain relation to the size of inlet, size of bowl, and speed of the machine. Most skim-milk outlets are made so as to discharge from .4 to about .9 or a little more, of the whole milk that enters the bowl. The remainder is the cream, which is forced to the center of the bowl and discharged through the cream outlet.

CONDITIONS AFFECTING EFFICIENCY OF SEPARATORS

1. Manner of Heating Milk. Owing to the fact that fat-globules rapidly change their shape and properties when exposed to heat and excessive agitation, it is essential that care should be taken in heating milk previous to skimming. When fat-globules are heated they become more liquid, and if stirred very much the clusters of fat-globules break up more rapidly. The individual globules, if stirred violently, will break or subdivide into several small ones. The higher the temperature of the milk, the more fluid it becomes, and the easier the separation. If milk is stirred violently, the individual fat-globules break up into smaller ones, which are separated from milk with difficulty. The table¹ on p. 162 illustrates what effect the different degrees of agitation of milk have upon the efficiency of separation.

In the experiments the diameter of the agitator in the pasteurizer was 14 inches. The speed at the periphery, at 250 revolutions per minute, was 15 feet per second.

It will be seen from the table (p. 162) that the higher the speed of the agitator, the greater the difficulty in getting a complete separation. Besides the speed of the agitator in the heating apparatus, undoubtedly the shape of the pasteurizer is a factor

¹ Hoard's Dairyman, Fort Atkinson, Wis.

	No of Experiments	Av. Fat Per Cent in Skim-milk
Milk heated in vat, not pumped	10	.117
Milk heated in pasteurizer, 200 rev. of agitator per min. .	8	.115
Milk heated in pasteurizer, 250 rev. of agitator per min. .	3	.118
Milk heated in pasteurizer, 300 rev. of agitator per min. .	8	.134
Milk heated in pasteurizer, 350 rev. of agitator per min. .	2	.143
Milk heated in pasteurizer, 400 rev. of agitator per min. .	7	.198
Milk heated in pasteurizer, 500 rev. of agitator per min. .	4	.225
Milk pumped by the turbine pump at 122° F.	3	.129
Milk pumped by the turbine pump at 64° F.	3	.119
Milk pumped with the pump, effective at 122°	3	.117
Milk pumped with the pump, effective at 64°	3	.115

in determining the efficiency of the subsequent separation. For instance, the milk in most horizontal pasteurizers is, even at low speed, exposed to considerable agitation.

If the milk is suddenly heated from a low temperature to about 80° or 90° F. and then skimmed, the heating does not facilitate the skimming process very much. It is essential that the milk be exposed to this temperature for a considerable time. The fat-globules do not warm as rapidly as the milk serum. This diminishes the difference between the specific gravity of the two substances, consequently completeness of separation becomes more difficult. If milk is heated to a high temperature, say, for instance, 170° F., the separation will be sufficiently complete without exposing the milk for any length of time to that temperature.

Machines are now made, and are on the market, which will bring the milk into such a condition that the fat-globules cannot be separated from it. The process is called "homogenization." It consists of bringing the milk under certain pressure, and then forcing it out through a special valve. This relief, through this special valve, breaks up the existing fat-globules into very minute ones, which cannot be separated from the milk by gravity methods, and which it is impossible to separate completely by centrifugal methods. Homogenization of milk is

carried on to some extent in Europe. The process practically insures uniform quality to the milk patrons in the distribution of milk in cities, and secures a more uniform consistency of the product.

2. Condition of the Milk.—In order to get complete separation, and keep the separator in good running order, it is essential that the milk should be in as good physical condition as possible. Coagulated, slimy, or otherwise viscous milk separates with difficulty. When such milk is on hand it should not be mixed with the milk that is in good condition, as it might tend to coagulate more of the good milk, and the coagulated or slimy lumps are likely to clog the separator. Such milk should be left until all the good milk has been separated. Then, if the coagulated or slimy milk is thoroughly stirred so as to reduce its lumpiness, it may be run through the separator successfully. It is a good plan not to feed the separator quite so heavily when this quality of milk is being run through. If the inlet is partly shut off, it will usually run through without clogging. Milk containing impurities in suspension should be thoroughly strained previous to separation.

Overfeeding the Separator.—When a separator is being overfed with milk there is a tendency for the machine to do less complete work. This is due to the fact that the more milk is being fed into the separator the less time it will be subjected to the centrifugal force. It is possible to underfeed the separator as well. As has been mentioned before, the inlet can be closed to such an extent as to cause nearly all the discharge to take place through the skim-milk tube.

As a rule when the machine has been set so as to allow the milk to flow in at a certain rate, it will continue to admit practically the same amount of milk all through the skimming period. Among the conditions which may alter the rate of inflow to some extent, are the amount of heat and the change of pressure, due to different amounts of milk in the receiving-vat. Temperature will slightly affect the rate of inflow. The higher the temperature, all other conditions being the same, the more milk will pass through the inlet.

3. Speed.—All modern machines have a device by which their speed can be determined. Most speed indicators consist of a little wheel, which, when pushed up against the spindle of the separator while running, turns around and permits the calculation of the speed of the separator. If the wheel on the speed-indicator makes 10 revolutions during ten seconds, the machine turns 1000 times during the same time. During one minute the separator will run six times as many revolutions, or 6000, as ten seconds is one-sixth of a minute. Most speed-indicators are so adjusted as to turn one revolution for every 100 revolutions of the machine. The higher the speed, the more thorough is the separation. Nearly all machines are balanced to do the best work at a certain definite speed, varying with different machines, and indicated in the directions for operating. It is essential that the machine should be brought up to speed gradually, and no milk be allowed to flow through it until after it has acquired its full speed.

During the run, all machines are likely to vary more or less in speed, owing to different causes. Pulleys are likely to slip on the shaft, and belts are likely to become loose, and thus cause variations in the speed. The steam pressure may get low, and cause all of the machinery in the creamery to run more slowly. This cause, however, is not a very common one where belt separators are used. If the engine has an automatic governor on it, the speed is usually quite uniform. Where steam-turbine machines are used, the speed of the machine is more likely to vary with the different amounts of steam pressure on the boiler. With turbine separators it is very essential to keep an even steam pressure. Some turbine separators have a safety-valve attached to prevent too high speed.

The reason why the prevention of a variation in speed is so essential is that a slight variation in the speed has a comparatively large effect upon reducing or increasing the centrifugal force. The centrifugal force generated in a machine varies according to the diameter of the bowl, and according to the speed of the machine. The greater the diameter of the bowl, the less speed or velocity is required in order to get a certain force. The centrifugal force varies in direct proportion to the

diameter of the bowl; that is, if the diameter of the bowl be doubled, then at the same speed, the centrifugal force has been doubled. The centrifugal force varies in quadratic proportion to the speed of the machine; that is, if the speed of the separator is doubled, the centrifugal force is increased four times. From this it will be seen that speed is a great factor in determining the centrifugal force generated. It is not a good plan to have the diameter of the bowl too large, for the following reasons: A large bowl is more likely to be thrown out of balance; it is harder to keep on the bearings; and it is heavier and more unhandy to handle. For these reasons it is better to lessen the diameter of the bowl and increase the speed. This, of course, is true only to a certain limit.

Steadiness in Running.—Smooth running of a separator is one of the first essentials. If a machine runs roughly, there will not be good separation, and it is dangerous to run it. The bowl itself is likely to jump out, or burst. The causes for unsteadiness in running are many. It may be due to a bent or sprung spindle; the machine not standing level; changing covers to bowls; using clamps which do not fit the bowl cover; unclean, worn-out bearings; condition of the bowl, and contrivances inside the bowl; and dented and rusty bowls. Occasionally it happens that a machine is run backwards. This is likely to cause the cover of the bowl to run off.

Thickness of Cream.—The efficiency of skimming depends to some extent upon the thickness of the cream skimmed. Most separators, however, will skim within quite a wide range as to thickness. The richness of cream usually skimmed by separators ranges from 25 per cent to 50 per cent. Most separators, however, will do good skimming even if the cream contains as high as 60 per cent fat. This, however, should be considered to be about the maximum, in order to get the best results from a separator.

Slush in Bowl.—As has been mentioned before, there is always a thick, slimy substance which adheres to the bowl-wall. The composition of separator-slime is, according to Fleischmann, as follows:

Water.....	67.3
Fat.....	1.1
Caseous matter.....	25.9
Other organic substances.....	2.1
Ash.....	3.6
	<hr/>
	100.0

At the center of the bowl, or along the perpendicular axis, there is always considerable cream. It is practically impossible to get all the cream out of the bowl, even if it is flushed with much water. The amount of slush varies somewhat with the different kinds of separators, and it is essential that this amount should be taken into consideration when the comparative skimming efficiency of different separators is considered. When the test extends over a comparatively long period, and the milk skimmed amounts to several thousand pounds, the bowl slush does not greatly affect the conditions for comparative results; but when the test is short, and only a hundred pounds of milk, or thereabout, is skimmed, the amount of fat left in the bowl-slush will have considerable influence upon the choice of a machine.

General Remarks.—In order to keep the separator in good running order, it must receive care. The belt should neither be too tight, nor too loose. If too tight it is likely to bind, heat, and set the bearings of the separator. If too loose it is likely to slip, and to wear out more quickly. The machine should be well oiled. It is better to use a trifle too much oil than not enough. If a bearing is once heated, the machine will never run as well again.

The bowl should be handled with great care. Bowls, or parts belonging to the bowl, can be kept from rusting by boiling them in water, or by steaming them thoroughly after they have been cleaned. If scalding-hot water is used before the milky portion has been washed off, the albuminoids will be scalded on to such a degree that it will be difficult to get them off. This applies to all dairy and creamery utensils. It is said that tin or ironware may be prevented from rusting by being dipped into

hot water after washing. If the bowl, pail, or whatever utensil it may be, is turned over to drain after being dipped in hot water, the heat taken up by the utensil will in a short time perfectly dry the apparatus. If the bowl is steamed, it should be heated thoroughly to make it dry quickly.

If the milk supply gets short during the run, and it is necessary to run the machine without feeding milk, the machine should always be flushed with lukewarm water. This will, in a measure, prevent clogging. Scalding-hot water should never be used for flushing the separator. The cream and skim-milk tubes should be carefully cleaned, with the special wire provided for that purpose, each time the machine is washed. The contrivances on the inside of the bowl should also be handled with care so as not to injure them in any way. They should be treated with hot water, as mentioned above, in order to keep them from rusting.

When the bowl is not to be used for some time, it should be oiled well to prevent it from rusting. It is easier to oil a separator bowl than it is to scour the rust off later on.

CHAPTER XIII

FARM SEPARATORS

THE factors which influence the richness of cream are dealt with in Part II of the chapter on "Variation of Fat in Milk and Cream," while those affecting the efficiency of skimming are dealt with in the chapter on "Separation of Cream." These factors apply equally to power and farm separators. The conditions under which farm separators are operated warrant this separate chapter upon this subject.

Introduction of Farm Separators.—Small, or hand, separators have been manufactured for a great many years, but their general adoption is of comparatively recent date. For instance, it was in 1894—not so very long ago—that hand separators were introduced into the large dairy state of Iowa. Thirty years ago practically all of our creameries were milk-receiving creameries, while to-day the great bulk of our creamery butter is made from cream separated on the farm by means of hand or farm separators. Naturally the people of the Central West (Iowa, Kansas, Nebraska, Missouri, Minnesota, Illinois and Indiana) have been foremost in the development of this system, as it is best suited to their conditions. It permits many of the farmers who engage in dairying in a comparatively small way to become patrons of creameries located at considerable distances from them.

Reasons for Introducing Farm Separators.—It requires an investment of about \$100 to purchase a hand separator; it may therefore be concluded that some good reasons lead farmers to make such an investment. The chief of these may be briefly stated as follows:

(1) The farmer is able to skim the milk immediately after it has been drawn, thereby enabling him to feed the milk while

it is in a warm, sweet, unadulterated condition. If he hauled the milk to the creamery, the skim-milk would be likely to come back in a sour and curdled condition, and at times watery. (In a well-conducted creamery these latter conditions do not exist.)

(2) The high cost of hauling in many instances makes it

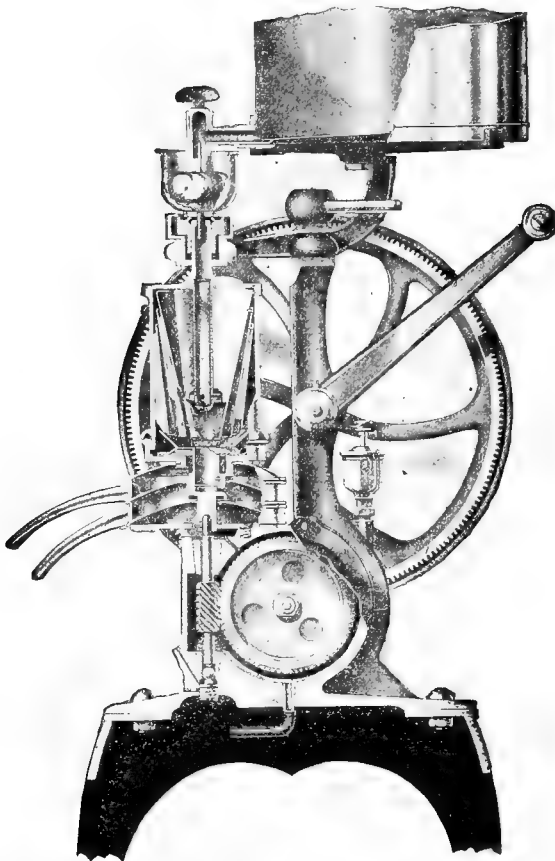

FIG. 51.—The Omega hand separator.

almost impossible to get the milk to the creamery. Even if the roads are good, the distance to the creamery is frequently so great that it is impossible to get haulers, nor is it practicable for every farmer to haul his own milk every day. Especially is this so during the busy season of the year. In the fall, when

milk is scarce, it is almost impossible for the hauler to get enough milk to make it profitable. In many cases it is necessary to pay an excessive price for hauling milk.

When cream routes are established instead of milk routes, one hauler can usually cover as much territory as three could under the milk system. Two thousand pounds of milk, testing 4 per cent and containing 80 pounds of fat, would represent approximately a load of milk. At 25 cents per 100 pounds, this would mean a cost of \$5.00 for getting that much milk hauled. If the same amount of butter-fat were hauled in the form of cream, it could be gathered for about 3 cents per pound of fat, or the cost of hauling in this particular case would be \$2.40. Under the milk system it would be necessary to haul the milk to the creamery every day, while under the cream system it is usually gathered every other day in the summer, and every three days in the winter. It is usually considered that there is a saving of about 2 to 3 cents per pound of butter-fat in hauling, by making use of the cream system instead of the milk system. This, of course, would vary according to local conditions.

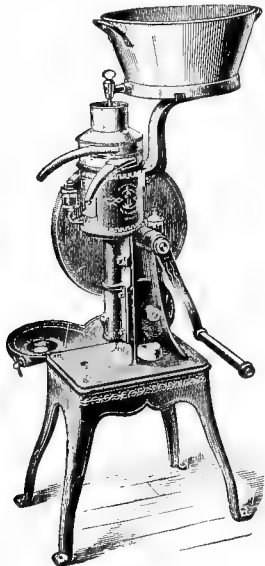

FIG. 52.—The De Laval hand separator (Baby No. 1).

3. The use of hand-separators makes farmers more independent than they are under the whole-milk system. They are not compelled to support their local creamery unless they deem it advisable. They can ship their cream to any place that they may choose. If the butter from the hand-separator cream is to be of as good quality as that made by the whole-milk system, the cream should be delivered as often as possible. *Every day* is preferable to every other day. In case frequent delivery is made, it becomes quite essential for the farmer to patronize the local creamery, as very few farmers keep sufficient cows to get enough

cream to pay them to ship by rail every day. Usually it does not cost much more to ship a can full of cream than it does to ship it half or three-quarters full.

Objections to Farm Separators.—Under the present system

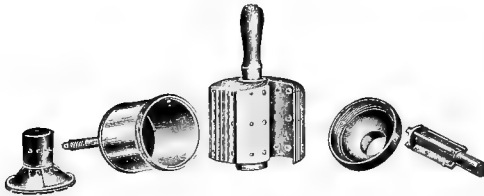
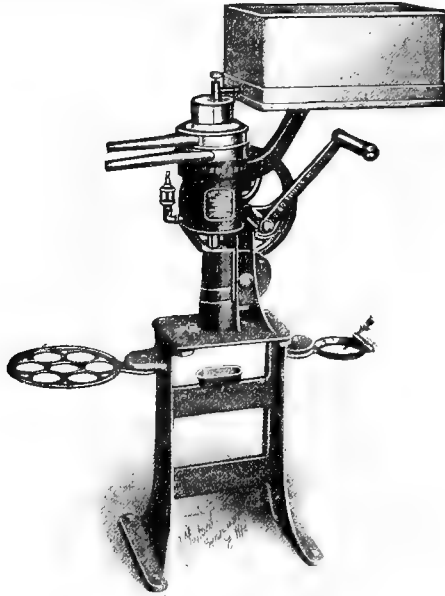

FIG. 53.—Simplex hand separator and the different parts of bowl.

of shipping cream long distances the quality of the butter made from it is often of a lower grade than that made from good whole milk. This is not due to any fault of the system, but to the poor care which the separator and cream may receive. The separator on the farm is sometimes kept in an unsuitable place, often in the

barn. If the milk is separated in such a place it will absorb odors and undesirable taints. The cream is not always taken care of properly after it is separated. The separators may not be cleaned well. A separator cannot be kept in good condition by simply flushing out the bowl with cold water at the end of each separation. It must be taken apart at the close of each skimming, and all the parts must be washed thoroughly in lukewarm water, and then scalded. The time and power required to skim the

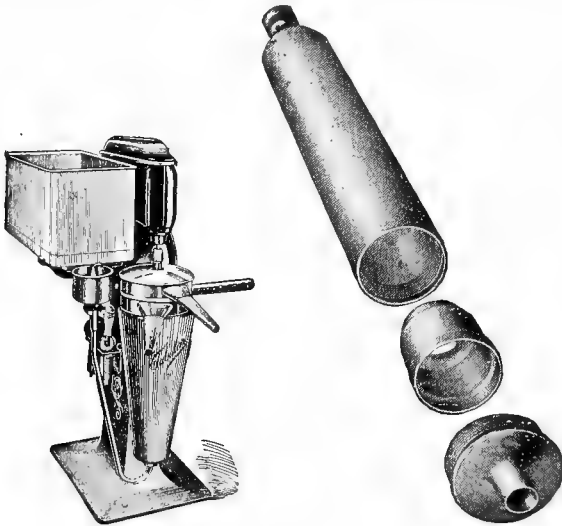

FIG. 54.—Sharples separator and parts of bowl.

milk and to care for the cream are in many instances regarded as objections to the system.

Thickness of Cream.—Most butter-makers at central plants prefer cream containing about 30 to 40 per cent of fat. Such cream is not thick enough to cause any inconvenience in sampling and weighing. It can be diluted with a good starter and ripened without becoming so thin as to produce unfavorable conditions for churning. By some it is deemed advisable to skim even thicker than this, up to 50 per cent. Cream containing this much fat, however, is difficult to handle, especially during cold weather. It becomes so stiff that it is difficult to pour, and there is also

danger of losing more or less cream through its adhering to the sides of the cans.

A thick cream is advisable from the farmer's standpoint.

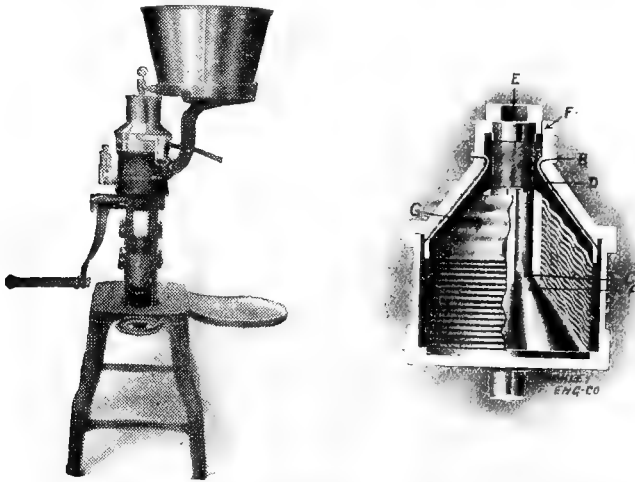

FIG. 55.—Peerless hand separator and cross-section of bowl.



FIG. 56.—Agos hand tester.

The thicker the cream is, the more skim-milk he will retain on the farm for feeding purposes. It can also readily be seen that if thin cream is skimmed greater can capacity is necessary,

and the express charges will be heavier than if the thicker cream were skimmed. Rich cream does not sour so rapidly as does thin cream.

The richness of cream can be readily ascertained by the use of a Babcock test, which every farmer should have in his possession. A whole outfit for testing fat in cream or milk can be had for about \$10.00 from any creamery supply-house. By the use of such a test, the farmer can test his cream and skim-milk. He can also test the milk of each individual cow in the herd, thereby ascertaining which ones are profitable. By the use of such a test on the farm, the farmer can test his cream daily, and compare

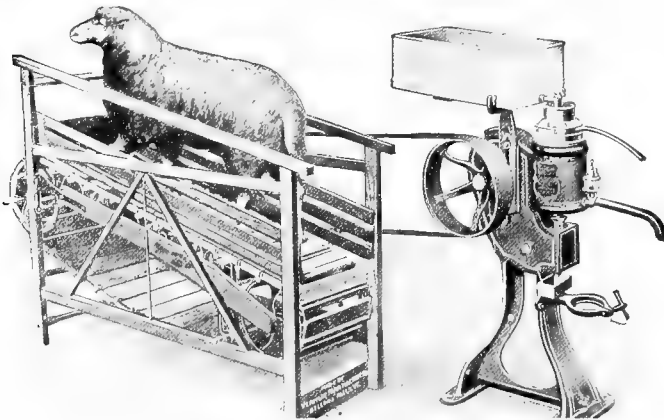

FIG. 57.—Tread-power attached to United States hand separator.

results with those from the creamery, thereby enabling him to detect any mistake which may happen at the creamery.

Power for Farm Separators.—Hand-power is often mentioned as an objection to farm separators. When a considerable quantity of milk is to be skimmed, it is certainly hard work to skim with hand-power. Windmills could not well be used as they do not give uniform speed. Tread-power is often used to run farm separators and is very well adapted to this purpose, as it is steady and uniform, and does not cost anything after the apparatus has once been purchased. The power can be supplied by using different kinds of animals. Sheep, goats, dogs, and

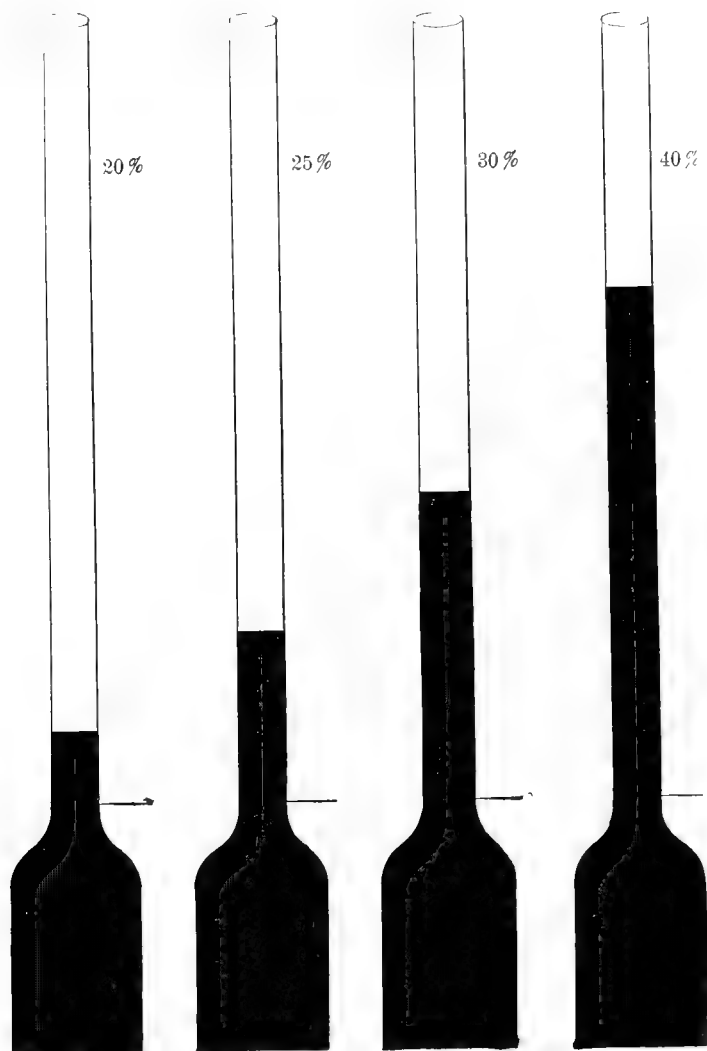

FIG. 58.—Showing the height to which cream free from air bubbles must be raised in a pipette to get 18 grams of cream. It shows that to measure cream in a pipette is inaccurate in cream testing. (Iowa State Dairy Com. Report, 1903.)

bulls are used for this purpose. The process does not usually last very long, and the work is not considered heavy. Steam is good power, but it is hardly ever obtainable on the farm. Small gasoline-engines are also used very successfully.

The machine should always run smoothly in order to get efficient skimming. It should never be stopped and started with a jerk. If it is started slowly there will be less danger of breaking any of the gearing parts. The bowl and inside parts should be kept from rusting as described previously on page 167. The bearings should be well oiled. It is a good plan to have an extra bearing or two on hand, so that if one happens to wear out another one can be put in. The bearings should be cleaned at

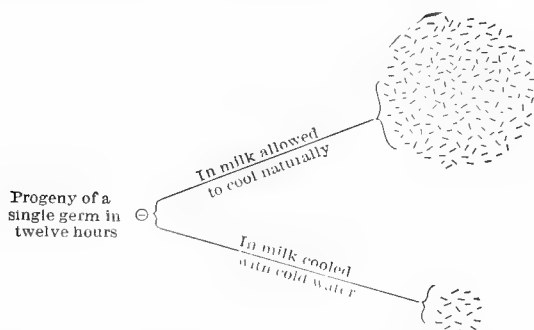

FIG. 59.—Showing the effect of cooling milk on the growth of bacteria. The beneficial results of early chilling are readily apparent. (From Bul. 62, Wis.)

intervals. When kerosene is occasionally used on the bearings they do not need to be cleaned so often, because it keeps them from gumming. The machine should be turned at the proper speed, as indicated in the directions. A thicker cream will result from rapid turning; consequently more skim-milk will be obtained. Slow turning causes inefficient skimming and thinner cream.

Care of Cream on the Farm.—The first step in the production of good cream is clean milking. This can be accomplished only when barn, cows, and utensils are clean. It is a good plan to dampen a cloth, and wipe off the cow's udder and sides previous to each milking. The milker should never wet his hands while

milking. Dust should not be stirred up in the barn during milking, as the dust particles carry with them a large number of

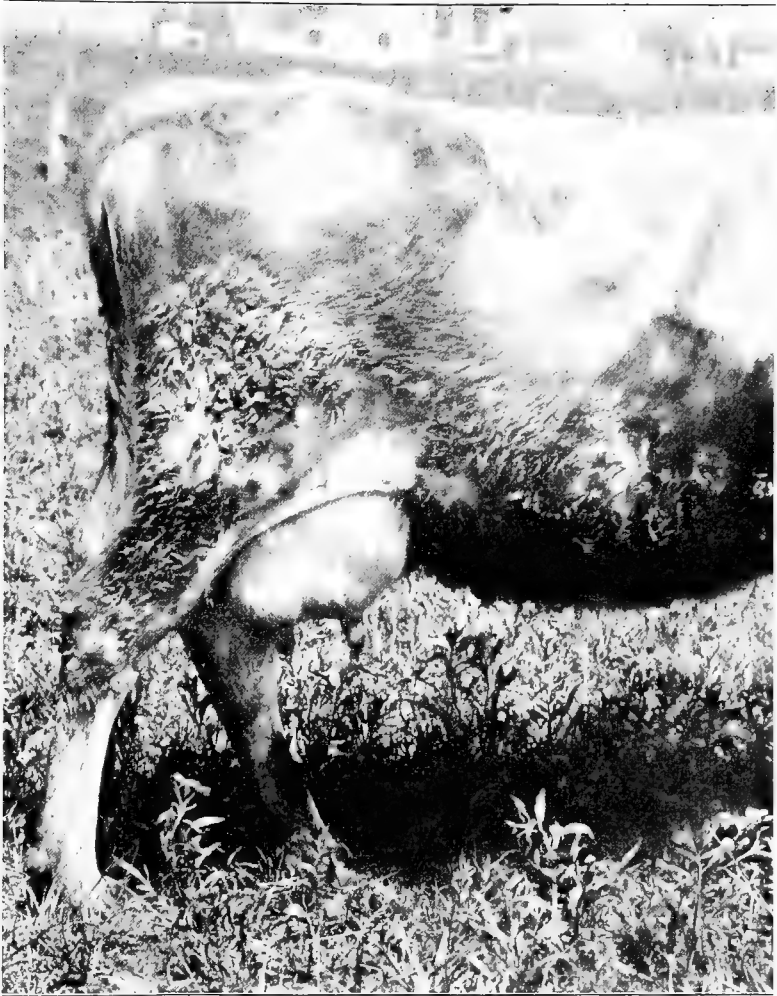

FIG. 60.—The condition of the cow shown in this cut is favorable for the accumulation of loose dirt (Bul 84, Ill)

undesirable germs, and when these settle in milk they are likely to produce taints. If cloth strainers are used they should be kept

scrupulously clean. It is advisable not to use them at all, as good sanitary wire-gauze strainers are inexpensive.



FIG. 61.—A clean cow. The dirt cannot adhere to this cow to so great an extent as to the one shown in Fig. 60. (Bul. 84, Ill.)

If these conditions are complied with, and the separator is kept in a good clean condition, the milk will have compara-

tively few germs in it. Some germs, however, will enter the milk, and in order to keep them from developing, it is essential to cool the cream or milk immediately. Low temperature retards and practically prevents the development of germ life. It is a well-known fact that when milk is kept cool, it will remain sweet much longer than if kept at a high temperature. Two milkings or skimmings should never be mixed unless both are well cooled first. In order to cool cream quickly, it should be stirred during cooling. The ordinary four-gallon shot-gun cans are good and suitable for keeping milk and cream. They have a large cooling surface in proportion to their cubical content. The milk or cream should be cooled as low as the water will cool it, and even lower than this if ice is obtainable. In keeping milk, the temperature should never go above 60° F. Cooling to 50° F., if it can be accomplished, is much more desirable for keeping milk or cream in good condition.

If considerable milk is handled, it is well to provide a milk-house. It should be built large enough to contain the separator, water-tank, and other utensils necessary for home butter-making, such as a churn and butter-worker. There should be plenty of windows on all sides to give good ventilation. The water-tank should be connected directly with the well, so that the water can be pumped directly to the tank holding the milk and cream. From this place the water can be run out into the stock-tank. This arrangement allows the milk to be kept at the lowest possible temperature.

It is just as essential to cool the milk during the winter as it is during the summer. By pumping water through this tank practically all the time, the water in the tank will be kept from freezing. It is well to keep the surface of the water higher than the surface of the milk in the can. This will prevent the milk from freezing so easily. If the cold is too severe, a tank-heater can easily be secured which will moderate the temperature a trifle.

Disposition of the Cream.—There are two ways of disposing of cream on the farm: (1) selling it to creameries or other parties, and (2) making it into butter on the farm. The former method is

usually the most advantageous. Creameries, as a rule, are better equipped to control the quality of butter. The price per pound of butter-fat is usually about 2 cents below "New York Extras." A few of the best creameries are able to pay more than that.

Shipping of Cream.—If cream is sent or shipped to creameries and central plants, it is essential that it be delivered as frequently as possible, and that it be delivered in cans which will help keep it in good condition. If cream is to be hauled any great distance and exposed to the sun, it is advisable to use special jacketed cans, which retard the transmission of heat. It is a good plan to cover the cans with a wet sack or cloth during the summer, and the use of a dry sack on the outside in the winter often prevents the cream from freezing.

Making Butter on the Farm.—If cream is kept in good condition and proper skill is applied, the best of butter can be made on the farm. Theoretically, better butter can be made on the farm than at the creamery, because all conditions can be controlled better. In the creameries one can of bad cream mixed with a quantity of good cream is likely to contaminate and injure the whole lot. The cream which is to be made into butter on the farm should not be over-ripened before it is churned. In creameries, starters are used to set up a

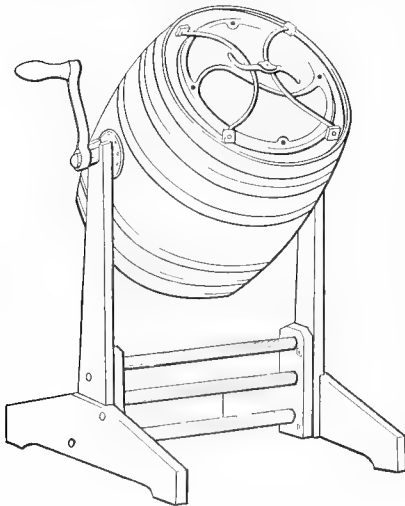

FIG. 62.—A barrel churn.

quick and desirable fermentation in the cream; conditions are usually such on the farm that it is not convenient and practical to use a starter. It is very essential that the cream be cooled to a low temperature (50° F.) and left at this temperature for at least two hours before it is churned; otherwise the butter is likely

to be greasy and salvy. Butter should be colored and salted to suit the market and season. About one-half to one ounce of salt to 1 pound of butter usually gives good results.

If a local trade can be secured, it is not necessary to pack the butter into tubs. In this case it may be kept in earthen jars. If no local trade can be secured, and it is essential to ship the butter, 20- or 30-pound

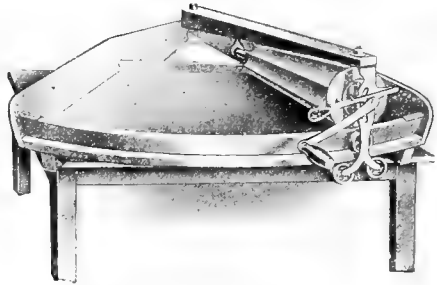

FIG. 63.—Skinner butter-worker.

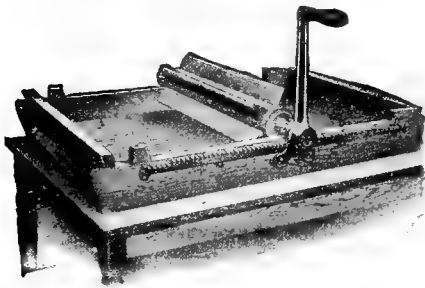
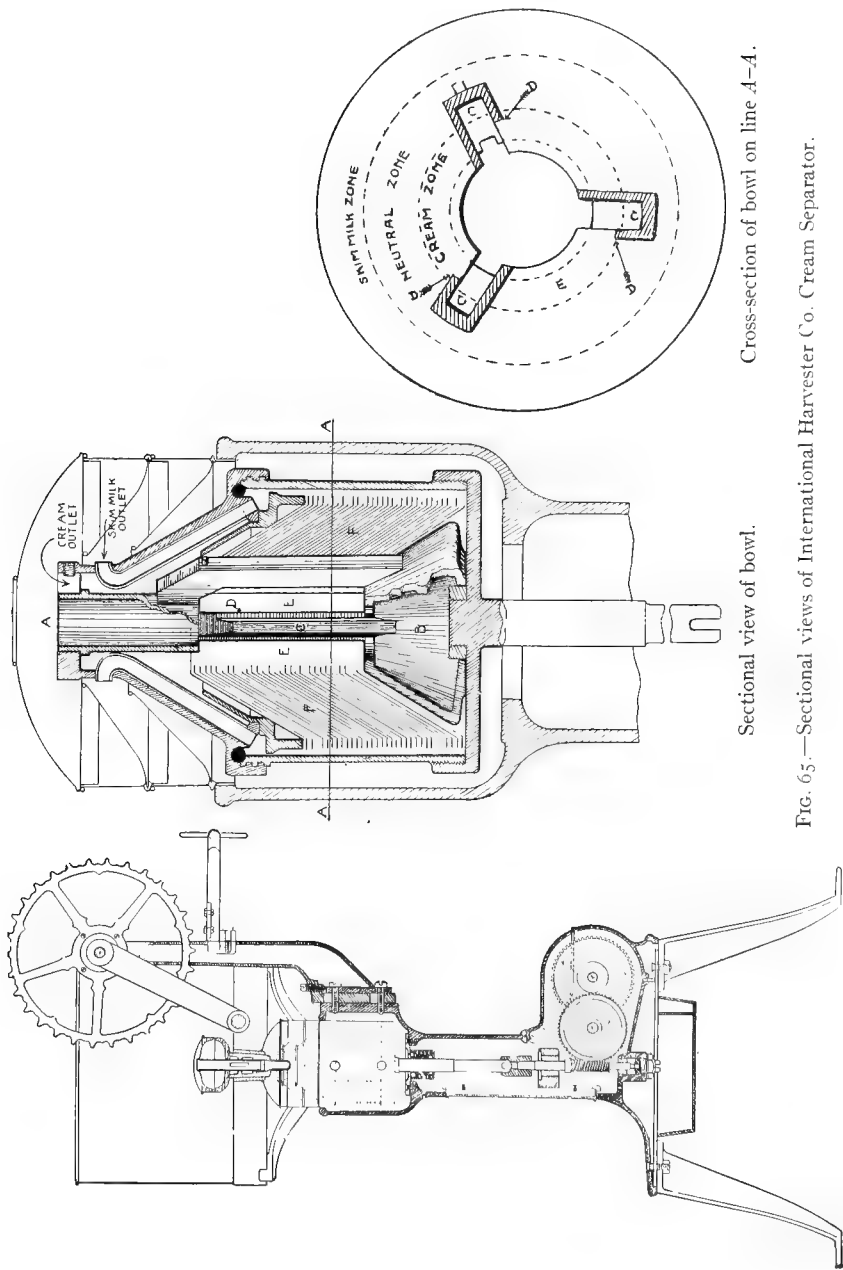

FIG. 64.—Wizard butter worker (Creamery Package Mfg. Co.)

tubs should be used. If a good quality and constant supply of butter can be secured throughout the whole year, it is an easy matter to find an excellent market at hotels or good restaurants. (For a more detailed discussion of butter-making, see Chaps. XVII and XVIII.) Putting up butter in prints and

wrapping them in parchment paper which bears the maker's name usually increases its selling price.



Sectional view of bowl.

Cross-section of bowl on line A-A.

FIG. 65.—Sectional views of International Harvester Co. Cream Separator.

CHAPTER XIV

NEUTRALIZATION

The "Neutralization" of Cream

Neutralization.—The principle of neutralization is not a new one. Its application in the laboratory is practically as old as the science of chemistry, but its application to cream is comparatively recent.

The principle is easily explained and understood. In chemistry there are two large classes of substances which are opposite to each other in action and have a strong affinity for each other, namely, bases (which include alkalies) and acids. A base and an acid, when brought together, react upon each other to form a new substance which is neither an acid nor an alkali, and is called a salt. For example, when hydrochloric acid and caustic soda react upon each other common salt and water are formed, thus,



Again, when either quicklime or slaked lime (hydrate of lime) reacts with hydrochloric acid they form calcium chloride, which is the salt commonly used for making the brine used in connection with refrigerator systems, as it can be reduced to a very low temperature without freezing.

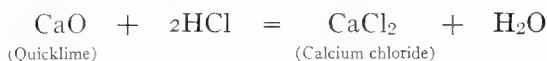

or

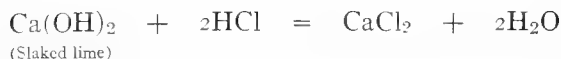

A definite quantity of a given alkali will always neutralize a definite quantity of a given acid. To take a concrete example: If upon trial we find that it takes 8 c.c. of a certain alkali solution to neutralize 10 c.c. of a given acid solution, subsequent trials will show that they always combine with or neutralize each other in exactly the same proportions. In a test of this kind we use an "indicator" to tell us when the solution tested changes from an acid to an alkali. If phenolphthalein be used it remains colorless so long as the medium is acid, but as soon as the acid is all neutralized and the liquid becomes alkaline to the slightest degree, this indicator turns red. Litmus shows blue when the medium is alkaline and red when it is acid.

The principle of neutralization has been applied in dairy work for many years, in the form of the different alkali tests used in cheese- and butter-making to determine the acidity of the milk or cream. The reagent used is an alkali solution of known strength, usually a caustic soda (NaOH) solution.

Lloyd, an English chemist, made use of it in connection with his study of the principles and practice of Cheddar cheese-making about thirty years ago, and Mann introduced his test, which is still in quite common use, in 1890. The principle of these different tests is the same. It is only in the details that they differ.

In these acidity tests the acidity of the milk or cream is reduced to the *neutral* point, or the point where the substance tested is neither acid nor alkaline. This is true and complete neutralization.

"NEUTRALIZATION" OF CREAM FOR BUTTER-MAKING

We now come to the use of the words "neutralization" and "neutralizer" in a new sense, in connection with cream. What is, in popular language, termed the "neutralization" of cream is, in reality, merely a lowering or reduction of its acidity to a point at which the cream can be efficiently pasteurized, without causing an excessive loss of fat in the buttermilk. The substances most commonly used for the purpose of reducing the acidity are milk

of lime and soda ash. Neither of these alkalies should ever be used to reduce the acidity of cream to the neutral point, as in doing this there is grave danger of injuring the quality of the butter made from it. The necessity for reducing the acidity of cream came in with the general use of the little hand separator on the farm. The volume of cream thus produced was small; hence, the holding of cream at home until a sufficient volume was accumulated for delivery resulted, in many cases, in cream being delivered in a very sour condition, or in such a condition that it could not be pasteurized unless the acidity was reduced.

There is some dispute as to who first used an alkali for reducing the acidity of cream so that it could be efficiently pasteurized. We find that in 1896, Babcock and Russell of Wisconsin issued Bulletin No. 54 explaining the preparation and use of viscogen for the purpose of restoring cream for city trade to its natural consistency, as in the process of heating the lime salts are thrown down and the cream assumes a very thin appearance. Viscogen is composed of cane-sugar and lime. We are told that one creamery in particular used viscogen as a neutralizer in sour cream at a very early date.

As far back as 1901-02, one of the authors conducted extensive experiments in the use of alkalies of various kinds for reducing the acidity of cream; and in so far as he knows he was the first to take up experimental work in reducing the acidity of cream for butter-making. Some butter-manufacturing firms, as early as 1905, used a lime preparation in the commercial manufacture of butter. Since then the practice has gradually grown until now it is very general.

Why do we neutralize cream? The authors believe that there is an entirely satisfactory answer to this pertinent question and hope to be able to show that modern creamery conditions demand and fully justify neutralization.

Butter, at best, is a perishable product—so much so that even butter of the best keeping quality must be placed in cold storage at a low temperature (close to 0° F.) if it is to be held any length of time and retain its good flavor. The souring or ripening of cream for butter-making has been practiced from time imme-

morial. Many farmers' wives have become so proficient in the art of ripening cream and the making of butter that they have gained an enviable reputation in their own communities. The system of ripening or souring cream had been practiced by the home dairies for a long time before alkali tests were used. At this early date it was the custom to ripen or sour the cream until it assumed a thick, granular appearance and had a pleasant sour taste. The flavor that cream imparts to butter depends upon the kind of organisms that predominate in it. The observance of sanitary methods on the part of the producer is conducive to the presence of the right species of bacteria in the cream. Cleanliness and sanitary methods should be observed by the makers, whether in the private dairy or in the factory. This is one of the first requisites of good butter-making; hence, all good butter-makers, whether in the private dairy or in the factory, observe cleanliness as a fast rule. Some butter-makers have gained national reputations by exhibiting butter in state and national butter contests, due to their ability to control the ripening of cream, by using pure lactic acid cultures in ripening to a certain degree of acidity. One of the main causes of undesirable flavors in cream is neglect on the part of the producers to thoroughly cleanse separators and other utensils that come in contact with the cream on the farm, thus allowing undesirable ferments to gain control. Another cause is neglect to cool cream, immediately after separation, to a low temperature. No time limit can be rightfully placed on the delivery of cream. Some patrons deliver cream once or twice a week, even during the summer, in such condition that the highest grade of butter can be manufactured from it, while others deliver cream daily and yet its flavor is such that it is impossible to make the finest quality of butter from it. The quality of butter produced depends upon the condition of the cream when it enters the churn. The fact that cream may be high in acid when it reaches the creamery is not an indication that poor butter will be made from it. If the acidity of the cream is reduced so that the cream can be efficiently pasteurized, a pure lactic acid culture can be used again to ripen it, as only a small portion of the milk-sugar

has been converted into acid at the first souring. A great deal of cream arrives at the factories in too sour a condition to make good butter unless the acidity is reduced. Hence, we can see the necessity of using a harmless alkali for reducing the acidity.

The introduction of the farm or hand separator has revolutionized the creamery business in America. While no reliable statistics are available as to the number of separators used among the dairymen of the country, it is estimated that 90 per cent of the butter produced in the creameries of the country is manufactured from hand separator cream. The principal reason for the general adoption of the hand separator on the farms by American dairymen was that they were always able to get sweet, warm skim-milk for feeding the young stock. When milk was sent to the creameries under the whole-milk system, it frequently happened through delays and other causes that the skim-milk would be in a very bad condition for feeding purposes upon its return to the farm. In addition to this, the lower cost of getting butter-fat to the creamery in the form of cream greatly reduced the expense. A can of cream has concentrated in it the fat of possibly ten or more cans of milk, and the cost per pound of fat for shipping a considerable distance is small. Consequently, there have been established large creameries equipped with the most modern machinery, not only for the manufacturing of butter but for utilizing the by-products as well. In addition to this, many such concerns have cut out the middleman and thus reduced the expenses of selling. Moreover, when a large volume of business is conducted at one place, more skilled labor can be employed. These are some of the reasons why the large or centralized creamery has developed so rapidly.

It has been estimated that 80 to 85 per cent of our butter is made from cream produced by farmers who are not dairymen in the full sense of that term. Dairying with them is a side line. Hence, the volume of cream produced is not sufficient to warrant its delivery to the creamery or buying station daily or even every other day. This means that a large volume of the cream received at the central plant is sour to a greater or less degree, although its flavor may be quite clean. When such cream has

been "neutralized" by milk of lime and pasteurized, it can be made into a very fine quality of butter. The president of a large creamery company, possibly the second largest manufacturer of creamery butter in this country, made a sworn statement that during the year 1920 they manufactured 27 million pounds of butter from cream that had been separated on the farms in various states and that 25 million pounds out of the 27 million pounds sold for extras or specials, some of it selling at a premium even above specials. All this butter was made from cream of which the acidity had been reduced by milk of lime. The fact that cream can be shipped a long distance has been the means of developing and stimulating dairying in sections of the country where there was not enough cream available to supply a local creamery. Where there is a sufficient volume of business to sustain a local creamery, and the same is rightly managed, no system will give greater returns to the producer. Whether a creamery is local or centralized, the same condition prevails.

To make butter of the best keeping quality it is necessary that the cream be pasteurized. Local creameries, as well as the large creameries, receive some very sour cream, but not usually in as great proportion. If such cream is to be pasteurized, it is essential that the acidity be reduced. Investigations conducted by the Dairy Division of the Federal Government and others have demonstrated that butter made from cream with a low acidity possesses better keeping qualities when placed in storage than butter made from cream having a high degree of acidity. Reducing the acidity of cream to the right point is a problem that necessitates intelligent care and an understanding of the effects of the use of an alkali. Cream that has been exceedingly high in acid, which has been reduced by limewater or some other harmless alkali substance, cannot be re-ripened with safety to the same degree of acidity as sweet cream that has never had its acidity reduced. Investigation has not revealed any satisfactory explanation of this fact. It would seem that the alkali used for reducing the acidity does not penetrate all the particles of cream, or, in other words, that the cream is not in a perfectly liquid condition. Some cream received at the factories is very sour

and lumpy. It may be that the solution used does not come in contact with the acid encased in the lumpy cream or particles of cream.

To get the best results from neutralization, a large fore-warmer should be used and the cream heated to 85° to 90° F., and thoroughly mixed by keeping the coil moving before and while adding the neutralizer. The neutralizer should be distributed as evenly as possible throughout the entire mass so that it will come in contact as far as possible with all particles of the cream.

Butter made from high-acid cream, whether pasteurized or unpasteurized, has a tendency to develop a pronounced fishy flavor when placed in storage. It is difficult to pasteurize sour cream if its acidity has not been reduced, as the heat causes the cream to become stringy or ropy, due to the coagulation of the casein. This is particularly true with thin cream. If the acidity of cream is high and it is churned in this condition, without having the acidity reduced, butter made from it will invariably be sour. This will not impair its food value nor will it make the butter injurious to health, but it will impair the flavor. Large classes of people in America and the European countries spread their bread with sour cream and regard it as a delicacy. The healthfulness of buttermilk, koumiss, and other fermented milks is well known.

In investigations pursued in the laboratory of the American Association of Creamery Butter Manufacturers on the heavy losses of butter-fat in buttermilk, it was found that the fat-globules that escape in the churning process and pass off in the buttermilk are the small globules which are encased in the meshes of the casein. The precipitation of the casein by heat in the process of pasteurization, where the acidity of the cream has not been reduced, causes extreme losses in the buttermilk. In some instances as much as 1 or 2 per cent of fat is found in buttermilk made from such cream. Hence, the reduction of the acidity for pasteurization is a necessity from an economic standpoint, if for no other reason.

Sour cream is a farm problem. Every creameryman would be

pleased to get cream in such a sweet condition that it would not be necessary to reduce the acidity for pasteurization. The alkalis most commonly used for reducing the acidity of cream are limewater and soda ash. The authors have never recommended the use of any other substance than limewater or milk of lime. The amount of lime used in reducing the acidity, somewhat less than one-tenth of 1 per cent, is so infinitesimal that it passes off in the buttermilk and has no effect upon the butter. The fat-globules of milk being coated with a film, the alkali solution used for reducing the acidity is mixed with the serum or the other component parts of cream rather than the butter-fat; hence, the small per cent of lime used practically all passes off with the buttermilk.

Investigations pursued under the direction of one of the authors showed that butter made from cream of which the acidity had been reduced by milk of lime did not contain any more lime than butter made from whole milk to which no lime had been added, and contained less lime than a number of samples of dairy or farm butter. Investigations of this butter were made at the Universities of Wisconsin, Cornell and Purdue. The explanation of the higher percentage of lime in dairy butter may possibly be that the cream for the farm butter was churned at a higher temperature than the cream from which the butter in the creameries was made. Butter churned at a high temperature will invariably contain a high percentage of casein. In such butter the lime will be held between the meshes of the casein; hence the high percentage of lime found in dairy butter, where no lime had been added to the cream, was undoubtedly due to the high temperature at which the cream was churned. Butter made from cream which has been subjected to reduction of acidity and pasteurization seems to give good satisfaction in the markets. This is particularly true during the storage season. Such butter is then sought by dealers in storage butter, owing to its excellent keeping qualities.

The use of limewater in milk is of long standing and well known. Lime is an essential constituent of dairy products. It is there to build the bones and to serve other essential physio-

logical purposes. Lack of lime causes not only rickets in the young, but also serious physiological disorders in the adult. Some physiologists urge the addition of lime to the diet. Its importance is thus expressed by Dr. Sherman of Columbia University:

“Calcium is present in still greater abundance. Milk contains slightly more calcium, volume for volume, than does lime water. As a rule the calcium content of the diet depends mainly upon the amount of milk consumed. In family dietaries where ordinary quantities of milk are used, the milk is apt to furnish about two-thirds of the total calcium of the diet. Without milk, it is unlikely that the diet will be as rich in calcium as is desirable either for the child or for the adult.”

In their recent Circular, No. 11, the United States Department of Agriculture and the United States Food Administration state their conception of the need of lime as follows:

“Milk gives your children lime and other salts which they need. There must be plenty of lime in their food, for a great deal of it is needed for their bones and teeth and a little for their blood and all other parts of their bodies. Right food, not drugs, is what children need. Big boys and girls and grown people, as well as children, need lime, because the bones are constantly wearing away little by little and must be replaced.”

Milk is the chief food for lime. It is much richer in it than other common foods. These lines stand for lime, the top one for the lime in a cup of milk, the others for the lime in a serving of some other foods. Notice how much more there is in milk than in the others.”

AMOUNT OF LIME IN

1 cup of milk



½ cup of carrots



1 egg



2 slices of bread



THE PREPARATION AND USE OF LIME AS A NEUTRALIZER

While there are other preparations, as those of the sodas, which are sometimes used for the neutralization of cream, the present discussion will be limited to the preparation and use of lime compounds as neutralizers.

Before proceeding with this, however, the authors would digress a little to give the results of analyses made of different samples of lime in the laboratory of the American Association of Creamery Butter Manufacturers. Eleven samples of lime from various parts of the United States were analyzed to ascertain their fitness for reducing the acidity of cream. The solubility of the limes in a 0.7 per cent lactic acid solution and their neutralizing power in terms of lactic acid were determined. The investigators were surprised to find that this amount of chemical work revealed very little more than was evident to the senses, aided by common sense. Here follow a few typical exhibits:

No.	Kind	Quality	Silica (Sand), Per Cent	Volatile, Per Cent	Iron and Clay, Per Cent	Calcium Oxide	Magnesium Oxide	Total
4	Hydrated	Good	0.31	11.45	0.73	88.60	0	100.00
11	Quick	Good	0.26	4.75	1.56	93.40	0	99.97
6	Quick	Good	0.36	7.00	1.25	58.20	33.54	100.35
3	Quick	Poor	2.43	1.35	6.44	55.40	34.19	99.81

No. 11 is a high calcium lime. Nos. 3 and 6 are magnesian limes. Although the percentages of calcium in 11 and 3 differ widely, they both give good results in reducing acidity. Magnesia acts like lime and is not as much inclined as lime to flavor the butter. It has a greater neutralizing power than calcium. No. 3 contained too much silica (sand), clay and iron. This was just as discernible by a physical inspection as by chemical analysis. The sand could be seen and felt and the clay made a granular yellow mixture.

There are two forms of lime that are used in the preparation of neutralizer, namely, quicklime in lump or in powder form, and hydrated lime, which is quicklime slaked by the lime-maker

instead of the user. As is shown below, it takes 74 pounds of completely hydrated lime to equal 56 pounds of quicklime for neutralizing purposes. Of course, the hydration is often only partial and then the difference is not so great.

It is really a lime mixture in the form of milk of lime, and not limewater, that is used, as lime is only soluble to a very small extent in water, and it would require too much of this to make its use practicable.

Lime should be free of such impurities as sand, clay and iron, and the lime preparations offered by responsible firms for neutralizing purposes usually are.

It is very important that the lime mixture be properly prepared. Much more trouble arises from improper preparation than from defects in the lime itself.

Quicklime is obtainable in powder form, packed in tin canisters. This form gives excellent satisfaction, as the quicklime is clean, uniform and free of waste material, and keeps until it is all used; whereas in lump lime there is considerable waste, through air slaking and the rejection of unsuitable lumps.

A very suitable mixture is made up in the proportion of 17 pounds of water to 3 pounds of quick lime. *The water should be as near boiling as possible and the lime should be added to the water and not the water to the lime.* The lime should be added in four installments instead of all at once, and the mixture stirred thoroughly after each addition of lime. If properly prepared the mixture will be very smooth and free of visible lime particles. When cool, it may be tested by putting the hand or a smooth butter spade into it and withdrawing. If smooth, showing no lime particles, it is a good mixture; if it shows a very few particles, it is fair; and if it shows many particles it is a poor mixture and is more likely to impart a limy taste than is a smooth mixture. A good mixture properly added to and mixed with the cream, and not in excess, is not nearly so likely to impart a limy taste to the butter.

A mixture of 3 pounds of lime to 17 pounds of water is the same as 15 pounds of lime to 85 pounds of water, or a 15 per cent mixture.

Whether one proceeds scientifically or mechanically in the preparation of his lime mixture, his work is based upon the following:

Molecular weight of quicklime, CaO , is $40 + 16 = 56$.

Molecular weight of hydrated, $\text{Ca}(\text{OH})_2$, is $40 + 2(16 + 1) = 74$.

Molecular weight of lactic acid, $\text{C}_3\text{H}_6\text{O}_3$, is

$$(3 \times 12) + 6 + (3 \times 16) = 90.$$

But the limes are bivalent. Hence 56 pounds of quicklime or 74 pounds of slaked lime will neutralize twice 90, or 180 pounds of lactic acid.

Hence 1 pound of lactic acid is neutralized by $\frac{56}{180} = .3111$ pound quicklime.

It takes 2.074 pounds of a 15-per cent mixture of quicklime to supply .3111 pound of quicklime. Hence 2.074 pounds of the quicklime mixture will neutralize 1 pound of lactic acid, or reduce the acidity of 1000 pounds of cream 0.1 per cent; and it is upon this figure, which is theoretically correct, that the following table is based:

TO REDUCE THE ACIDITY OF CREAM TO .25 PER CENT

Cream (Pounds)	INITIAL ACIDITY OF CREAM														
	.30	.35	.40	.45	.50	.55	.60	.65	.70	.75	.80	.85	.90	.95	
	POUNDS OF 15 PER CENT LIME MIXTURE NEEDED														
100	.1	.2	.3	.4	.5	.6	.7	.8	.9	1.0	1.1	1.2	1.3	1.5	
500	.5	1.0	1.6	2.1	2.6	3.1	3.6	4.1	4.7	5.2	5.7	6.2	6.7	7.3	
1000	1.0	2.1	3.1	4.1	5.2	6.2	7.3	8.3	9.3	10.4	11.4	12.4	13.4	14.5	
1500	1.5	3.1	4.7	6.2	7.8	9.3	10.9	12.4	14.0	15.6	17.2	18.7	20.2	21.8	
2000	2.1	4.1	6.2	8.3	10.4	12.5	14.5	16.6	18.7	20.7	22.8	24.9	27.0	29.0	
2500	2.6	5.2	7.8	10.4	13.0	15.6	18.1	20.7	23.3	25.9	28.5	31.1	33.7	36.3	
3000	3.1	6.2	9.3	12.4	15.5	18.7	21.8	24.9	28.0	31.1	34.2	37.3	40.4	43.6	
3500	3.6	7.2	10.9	14.5	18.1	21.8	25.4	29.0	32.7	36.3	39.9	43.6	47.2	50.8	
4000	4.1	8.3	12.4	16.6	20.7	24.9	29.0	33.2	37.4	41.5	45.7	49.8	53.9	58.1	
4500	4.6	9.3	14.0	18.7	23.3	28.0	32.7	37.3	42.0	46.7	51.3	56.0	60.6	65.3	
5000	5.2	10.4	15.6	20.7	25.9	31.1	36.3	41.5	46.7	51.8	57.0	62.2	67.4	72.6	
5500	5.7	11.4	17.2	22.8	28.5	34.2	39.9	45.6	51.3	57.0	62.7	68.4	74.1	79.9	
6000	6.2	12.4	18.7	24.9	31.1	37.3	43.6	49.8	56.0	62.2	68.4	74.7	80.9	87.1	
6500	6.7	13.5	20.3	27.0	33.7	40.4	47.2	53.9	60.6	67.4	74.1	80.9	87.6	94.4	
7000	7.3	14.5	21.8	29.0	36.3	43.6	50.8	58.1	65.4	72.6	79.9	87.1	94.4	101.6	

The common practice in creamery work is to measure the lime mixture, in adding it to the cream, instead of weighing it. In case this is done the mixture should be made up so that there will be 12.5 pounds of quicklime in 10 gallons of the mix, that is, this quantity of lime should be mixed with about 8 gallons of hot water and then brought up to 10 gallons by adding sufficient hot water. This water to be added should be heated in an open vessel so as to drive off any carbonic acid gas there may be in it, and should not be added directly from a hose or tap.

In 10 gallons of the mixture there are 12.5 pounds lime.

In 1 quart of the mixture there is $\frac{12.5}{40} = .3125$ pound lime.

We have already shown that .3111 pound quicklime will reduce the acidity of 1000 pounds cream .1 per cent. Hence, 1 quart of the lime mixture, which contains .3125 pound quicklime, will reduce the acidity of 1000 pounds cream $\frac{.1 \times .3125}{.3111} = .1004$ per cent = .1 per cent practically. Or, 1 pint of the lime mixture will reduce the acidity of 1000 pounds cream .05 per cent. It is upon these figures that the table on page 196 is based.

How many pints of lime mixture will it take to reduce the acidity of 3400 pounds of cream from .70 to .25 per cent? In the column under .70 and opposite 3400, this is given as 30.5 pints. The same quantity of lime mixture would be used for all acidities nearer to .70 per cent than either .65 per cent or .75 per cent. This principle applies all through the table.

Note the simple numbers opposite 1000 pounds of cream. The quantity of mixture required for any weight of cream can be quickly determined by multiplying the weight of cream by the amount of mixture required to reduce the acidity of 1000 pounds of cream to .25 per cent and dividing by 1000 (or pointing off three decimal places). Example:

How many pints of lime mixture will be required to reduce the acidity of 6300 pounds of cream from .80 per cent to .25 per cent?

1000 pounds of cream require 11 pints of mixture.

6300 pounds of cream require $11 \times 6.300 = 69.3 = 69.5$ pints of mixture.

PINTS OF LIME MIXTURE REQUIRED TO REDUCE ACIDITY TO
25 PER CENT

Lbs. of Cream	PER CENT OF ACID IN CREAM														
	.30	.35	.40	.45	.50	.55	.60	.65	.70	.75	.80	.85	.90	.95	1.00
100			.5	.5	.5	.5	.5	1.0	1.0	1.0	1.0	1.0	1.5	1.5	1.5
200		.5	.5	1.0	1.0	1.0	1.0	1.5	1.5	2.0	2.0	2.0	2.5	2.5	3.0
300	.5	.5	1.0	1.0	1.5	2.0	2.0	2.5	2.5	3.0	3.5	3.5	4.0	4.0	4.5
400	.5	1.0	1.0	1.5	2.0	2.5	3.0	3.0	3.5	4.0	4.5	5.0	5.0	5.5	6.0
500	.5	1.0	1.5	2.0	2.5	3.0	3.5	4.0	4.5	5.0	5.5	6.0	6.5	7.0	7.5
600	.5	1.0	2.0	2.5	3.0	3.5	4.0	5.0	5.5	6.0	6.5	7.0	8.0	8.5	9.0
700	.5	1.5	2.0	3.0	3.5	4.0	5.0	5.5	6.5	7.0	7.5	8.5	9.0	10.0	10.5
800	1.0	1.5	2.5	3.0	4.0	5.0	5.5	6.5	7.0	8.0	9.0	9.5	10.5	11.0	12.0
900	1.0	2.0	2.5	3.5	4.5	5.5	6.5	7.0	8.0	9.0	10.0	11.0	11.5	12.5	13.5
1000	1.0	2.0	3.0	4.0	5.0	6.0	7.0	8.0	9.0	10.0	11.0	12.0	13.0	14.0	15.0
1100	1.0	2.0	3.5	4.5	5.5	6.5	7.5	9.0	10.0	11.0	12.0	13.0	14.5	15.5	16.5
1200	1.0	2.5	3.5	4.5	6.0	7.0	8.5	9.5	11.0	12.0	13.0	14.5	15.5	17.0	18.0
1300	1.5	2.5	4.0	5.0	6.5	8.0	9.0	10.5	11.5	13.0	14.5	15.5	17.0	18.0	19.5
1400	1.5	3.0	4.0	5.5	7.0	8.5	10.0	11.0	12.5	14.0	15.5	17.0	18.0	19.5	21.0
1500	1.5	3.0	4.5	6.0	7.5	9.0	10.5	12.0	13.5	15.0	16.5	18.0	19.5	21.0	22.5
1600	1.5	3.0	5.0	6.5	8.0	9.5	11.0	13.0	14.5	16.0	17.5	19.0	21.0	22.5	24.0
1700	1.5	3.5	5.0	7.0	8.5	10.0	12.0	13.5	15.5	17.0	18.5	20.5	22.0	24.0	25.5
1800	2.0	3.5	5.5	7.0	9.0	11.0	12.5	14.5	16.0	18.0	20.0	21.5	23.5	25.0	27.0
1900	2.0	4.0	5.5	7.5	9.5	11.5	13.5	15.0	17.0	19.0	21.0	23.0	24.5	26.5	28.5
2000	2.0	4.0	6.0	8.0	10.0	12.0	14.0	16.0	18.0	20.0	22.0	24.0	26.0	28.0	30.0
2100	2.0	4.0	6.5	8.5	10.5	12.5	14.5	17.0	19.0	21.0	23.0	25.0	27.5	29.5	31.5
2200	2.0	4.5	6.5	9.0	11.0	13.0	15.5	17.5	20.0	22.0	24.0	26.5	28.5	31.0	33.0
2300	2.5	4.5	7.0	9.0	11.5	14.0	16.0	18.5	20.5	23.0	25.5	27.5	30.0	32.0	34.5
2400	2.5	5.0	7.0	9.5	12.0	14.5	17.0	19.0	21.5	24.0	26.5	29.0	31.0	33.5	36.0
2500	2.5	5.0	7.5	10.0	12.5	15.0	17.5	20.0	22.5	25.0	27.5	30.0	32.5	35.0	37.5
2600	2.5	5.0	8.0	10.5	13.0	15.5	18.0	21.0	23.5	26.0	28.5	31.0	34.0	36.5	39.0
2700	2.5	5.5	8.0	11.0	13.5	16.0	19.0	21.5	24.5	27.0	29.5	32.5	35.0	38.0	40.5
2800	3.0	5.5	8.5	11.0	14.0	17.0	19.5	22.5	25.0	28.0	31.0	33.5	36.5	39.0	42.0
2900	3.0	6.0	8.5	11.5	14.5	17.5	20.5	23.0	26.0	29.0	32.0	35.0	37.5	40.5	43.5
3000	3.0	6.0	9.0	12.0	15.0	18.0	21.0	24.0	27.0	30.0	33.0	36.0	39.0	42.0	45.0
3100	3.0	6.0	9.5	12.5	15.5	18.5	21.5	25.0	28.0	31.0	34.0	37.0	40.5	43.5	46.5
3200	3.0	6.5	9.5	13.0	16.0	19.0	22.5	25.5	29.0	32.0	35.0	38.5	41.5	45.0	48.0
3300	3.5	6.5	10.0	13.0	16.5	20.0	23.0	26.5	29.5	33.0	36.5	39.5	43.0	46.0	49.5
3400	3.5	7.0	10.0	13.5	17.0	20.5	24.0	27.0	30.5	34.0	37.5	41.0	44.0	47.5	51.0
3500	3.5	7.0	10.5	14.0	17.5	21.0	24.5	28.0	31.5	35.0	38.5	42.0	45.5	49.0	52.5
3600	3.5	7.0	11.0	14.5	18.0	21.5	25.0	29.0	32.5	36.0	39.5	43.0	47.0	50.5	54.0
3700	3.5	7.5	11.0	15.0	18.5	22.0	26.0	29.5	33.5	37.0	40.5	44.5	48.0	52.0	55.5
3800	4.0	7.5	11.5	15.0	19.0	23.0	26.5	30.5	34.0	38.0	42.0	45.5	49.5	53.0	57.0
3900	4.0	8.0	11.5	15.5	19.5	23.5	27.5	31.0	35.0	39.0	43.0	47.0	50.5	54.5	58.5
4000	4.0	8.0	12.0	16.0	20.0	24.0	28.0	32.0	36.0	40.0	44.0	48.0	52.0	56.0	60.0
4100	4.0	8.0	12.5	16.5	20.5	24.5	28.5	33.0	37.0	41.0	45.0	49.0	53.5	57.5	61.5
4200	4.0	8.5	12.5	17.0	21.0	25.0	29.5	33.5	38.0	42.0	46.0	50.5	54.5	59.0	63.0
4300	4.5	8.5	13.0	17.0	21.5	26.0	30.0	34.5	38.5	43.0	47.5	51.5	56.0	60.0	64.5
4400	4.5	9.0	13.0	17.5	22.0	26.5	31.0	35.0	39.5	44.0	48.5	53.0	57.0	61.5	66.0
4500	4.5	9.0	13.5	18.0	22.5	27.0	31.5	36.0	40.5	45.0	49.5	54.0	58.5	63.0	67.5
4600	4.5	9.5	14.0	18.5	23.0	27.5	32.0	37.0	41.5	46.0	50.5	55.0	60.0	64.5	69.0
4700	4.5	9.5	14.0	19.0	23.5	28.0	33.0	37.5	42.5	47.0	51.5	56.0	61.0	66.0	70.5
4800	5.0	9.5	14.5	19.0	24.0	29.0	33.5	38.5	43.0	48.0	53.0	57.5	62.5	67.0	72.0
4900	5.0	10.0	14.5	19.5	24.5	29.5	34.5	39.0	44.0	49.0	54.0	59.0	63.5	68.5	73.5
5000	5.0	10.0	15.0	20.0	25.0	30.0	35.0	40.0	45.0	50.0	55.0	60.0	65.0	70.0	75.0
6000	6.0	12.0	18.0	24.0	30.0	36.0	42.0	48.0	54.0	60.0	66.0	72.0	78.0	84.0	90.0

This is a general solution which applies to any weight of cream.

Where lime is completely slaked or hydrated it takes a little over 32 per cent more of it than of quicklime (74 pounds as against 56 pounds) to make the same strength of mixture. As the mixture upon which the table (p. 196) is based contains 12.5 pounds of quicklime to 10 gallons, it would require 16.5 pounds of hydrated lime to 10 gallons to make the same strength of mixture. If the lime is only partially slaked it will, of course, take less than 16.5 pounds.

The quantities of lime indicated for making the mixture are theoretically correct, but the individual user will be obliged to determine by test whether the mixture is right in strength for his cream. It may be necessary to use a little more or a little less lime than indicated, in making the mixture, probably a little less if any change has to be made. If necessary, a slight change may be made in the strength of the mixture to avoid changing the table.

In investigations conducted by Hunziker, in which he used the strength and quantity of lime mixture supposed to be sufficient to reduce the acidity of the cream to .25 per cent, he secured the following *average results*:

	Per Cent
Initial acidity of cream75
Acidity three hrs. after neutralizing, pasteurizing and cooling.33

In other words, whereas the acidity should have been reduced by .50 per cent (.75 - .25) it was only reduced by .42 per cent (.75 - .33). This means that $(.33 - .25) \div .50$ or $\frac{8}{50} = 16$ per cent of the neutralizer was not used, or that this mixture would need to be strengthened to the extent of the addition of 15 to 20 per cent more lime.

On the other hand, Hunziker found that when enough lime mixture was added to a pure lactic acid solution to theoretically reduce its acidity to .25 per cent it actually did reduce it to this point. The conclusion he reached, through his investigations, was that some of the lime added to cream attaches itself to the

casein and therefore all of it is not used up in the neutralization of the lactic acid in the cream.

The strength of a milk of lime mixture can be increased in either of two ways, (*a*) through the use of a larger proportion of lime, (*b*) through the use of lime containing a larger proportion of magnesium oxide, which is stronger, pound for pound, than calcium oxide.

When a lime mixture is made up in small quantities, a ten-gallon can will suffice for this purpose. But where larger quantities are required a cylinder-shaped tank similar to a starter tank, with an agitator in it, should be used. This can be of any suitable capacity, say 100 to 200 gallons. A simple gage may be used for measuring the contents. The user must remember that he is dealing with a mixture and not a solution, and that not only must there be a thorough agitation at the time the mixture is made but this must be repeated, to a lesser degree, whenever any of the mixture is used, as the lime settles.

Although the best limes do not contain 100 per cent calcium oxide, they usually contain enough magnesium oxide, which is stronger pound for pound than calcium oxide, to make up for this shortage.

There are some points that should be kept carefully in mind in the preparation and use of neutralizers.

The lime does not act so quickly and completely that its full effect is secured immediately. For this and other reasons, the acidity of the cream after pasteurization is lower than it was before pasteurization. The amount of drop in acidity varies with the cream, lime mixture and locality.

Some creameries add the lime mixture directly to the cans of cream. Some run it by a faucet into either the dump vat or the pasteurizer. Others fill a supply vat or forewarmer and then reduce the acidity to the desired point. The last method is the best.

The authors believe there is yet considerable to be learned about methods of applying neutralizer to cream in order to secure the best results and avoid unnecessary losses of fat in the buttermilk.

A careful determination of the acidity of the cream should always be made both before adding the neutralizer and after it is pasteurized and cooled. It may be found necessary to reduce the acidity of the cream a little more, or on the other hand it may be found that the acidity of the cream is being reduced too much. This determination will thus act as a guide for future work.

If the cream is to be ripened again the acidity is usually reduced to 0.15 per cent to .22 per cent (9° to 12° Mann's) and then ripened to the desired acidity.

Some prefer the use of slaked or hydrated lime. While hot water must be used in the preparation of the quicklime mixture, the hydrated lime should always be mixed with cold water.

OTHER NEUTRALIZERS

Some creameries use carbonate and bicarbonate of soda—commonly spoken of as soda ash—as neutralizers. The soda ash is very soluble in water and forms a clear liquid solution. This is more easily made and added to the cream than is the lime mixture, and doubtless this is the main reason for its use.

What has already been said indicates the authors' preference for the use of lime as a neutralizer and the reasons for this preference. The following points may therefore be treated briefly:

Lime is something that is well known and generally regarded as clean and wholesome, and the use of it in the neutralization of cream will not offend, in the slightest degree, the susceptibilities of the most fastidious.

Attention is frequently drawn, by physiologists, physicians and students of dietetics, to the necessity for a liberal supply of lime in the diet of children and adults, and to the fact that in many foods there is a shortage of this constituent.

Limewater is commonly used as an accessory to and a corrective of the foods of hospital patients and of children and infants.

While it is true, as has already been pointed out, that the

lime used in the cream passes off in the buttermilk, yet it is important that the consumer feel assured that the substance used as a neutralizer is something which is not foreign to milk, cream and butter and is wholesome, and to which no objection can be taken.

CHAPTER XV

PASTEURIZATION

Definition.—As applied to butter-making and city milk, pasteurization may be defined as a process of heating milk or cream to a temperature sufficiently high to destroy the great majority of the bacteria and other ferments contained therein and cooling it quickly to a low temperature. The name is derived from Louis Pasteur, an eminent French scientist, who made the discovery in the years 1860–64, that if wines were heated to a certain temperature (70° C. or 158° F.), and cooled again, fermentation would stop.

In 1884 Soxhlet applied the method of heating to milk for destroying bacteria.

Storch Test for Pasteurization.—Storch, at the Royal Agricultural Experiment Station, Copenhagen, Denmark, was the first to apply general pasteurization to cream for butter-making. Denmark has a law making pasteurization compulsory. This law was enacted to prevent the spread of tuberculosis among the herds. The law requires that milk or cream must be heated to 80° C., or 176° F. Samples of skim-milk from the creameries are required to be sent to the Experiment Station where they are tested by the Storch test to ascertain if creameries are complying with the requirements of the law.

Storch found that of all the reagents that might be used for determining whether milk or cream had been heated to 80° C. or 176° F., the best was paraphenylene diamine. This compound ordinarily gives a brown color when acted upon by "active" oxygen, but in the presence of casein in milk the color is a beautiful indigo blue.

To carry out the test about 5 c.c. of milk or cream are put

into a test-tube and one or two drops of a 0.2 per cent solution of hydrogen peroxide is added from a dropping bottle, also two drops of a 2 per cent solution of paraphenylene diamine, from a dropping bottle. Brown dropping bottles should be used to prevent the light from weakening the reagents. The test-tube is then well shaken, and if the milk has not been heated above 78°C ., or 172°F ., or if not heated at all, an intense blue coloration is produced. If at once or after half a minute the milk becomes bluish-grey, it indicates that it has been heated to a temperature of 78°C . to 80°C ., or 172°F . to 176°F . When the color of the milk is unchanged after addition of the reagents, it may be concluded that the heating has exceeded 80°C . The blue color that develops on standing has no significance.

Storch's test has shown itself to be the most reliable of all the methods proposed for distinguishing heated from unheated milk. All the so-called improvements which have been advocated by other chemists have proven to be of no benefit, often indeed the opposite.

If during the pasteurization of the milk the temperature falls below 80°C . for a time, the whole of the milk after being mixed reacts to Storch's test. The sensibility of the test is so great that the admixture of 10 per cent of milk which has only been heated to 78°C ., suffices to make the whole volume of milk react to the test.

Pasteurization Temperatures.—In pasteurizing or heating milk for city trade or immediate consumption, low temperatures are used. This is done for the purpose of avoiding a cooked or heated taste. The method found most satisfactory for milk is to heat to 145°F ., and hold at this temperature for twenty minutes. This is known to the trade as the holding method.

Where the flash or instantaneous method is used, the milk or cream is heated to a temperature of 175° to 190°F . The temperatures most commonly used in butter-making in creameries are 180 to 185°F . Of late years the higher temperatures have been used for butter-making, even in the holding method.

Marker, in the Canadian Northwest, recommends heating to 170 or 175°F ., and holding for fifteen or twenty minutes. This

method of heating has been recommended by him for the purpose of destroying the enzymes in the cream. Butter made from cream thus treated has shown unusually good keeping qualities, and he reports that it does not go fishy when placed in storage. One of the advantages of pasteurization is that it destroys all the pathogenic micro-organisms in the cream if any be present. Efficient pasteurization destroys from 99.5 to 99.9 per cent of the organisms present in cream. Pasteurization, however, does

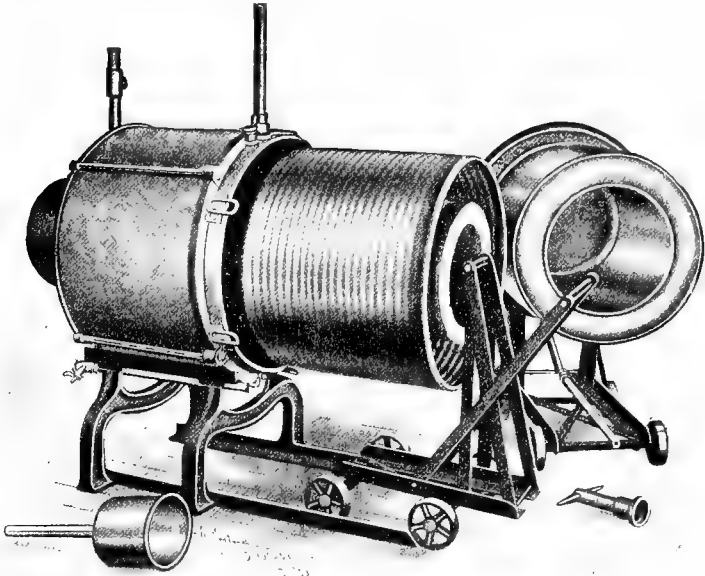

FIG. 66.—The Simplex regenerative pasteurizer (apart).

not put poor cream in a condition where good butter can be made from it.

Pasteurization and sterilization are not the same. The latter means that milk or cream, or any other liquid substance, has been heated so often or to a high enough temperature to entirely destroy every living micro-organism present. In order to get a substance thoroughly sterilized without heating under pressure, it is essential that it be heated about thirty minutes on each of three or more consecutive days.

Good Milk and Cream Important.—The quality of butter made from pasteurized cream will depend to a very large extent upon the condition of the milk or cream used. If milk or cream is sweet and free from obnoxious flavors at the time of pasteurization, the quality of the butter made from it will be good, provided that the butter is not injured in the process of manufacturing. The quality of the cream used has a bearing not only upon the quality of the butter made from pasteurized cream but upon that made from unpasteurized cream as well.

The impression prevails to some extent that butter made from raw cream will not possess keeping qualities and that if placed in cold storage it will develop a fishy flavor. Investigations pursued by one of the authors do not bear this out. In 1907 he conducted a series of experiments at Strawberry Point Creamery, Strawberry Point, Iowa, during the month of July. This experiment was conducted under regular creamery conditions, and was carried on for a period of two weeks. Apparatus was moved from the Iowa Experiment Station for making complete analyses of the butter and records of everything pertaining to this work were kept. The Strawberry Point Creamery at this time was receiving about 50,000 pounds of milk daily. The milk was received from the patrons in cylinder-shaped 20-gallon cans. It was inspected at the wagons, and any milk found slightly sour or tainted was rejected. Power separators were used for separating the cream from the milk, and the cream separated contained a high per cent of fat, the fat-content, after starters had been added, varying from 37 to 39 per cent. The cream used was in as perfect a condition as cream delivered for butter-making purposes can possibly be. Pure culture starters were used for souring or ripening it. About half the butter was made from unpasteurized cream, and the other half from pasteurized cream. In every case, two different churnings of butter were made from the same vat of cream, or the cream was divided so that two separate churnings were made. The full object of the experiment will be dealt with in another chapter. Two 60-pound tubs of butter were packed from each churning and shipped to Gude Bros., New York City. Each one of these tubs bore a special

number. When the shipment of butter arrived in New York, half was to be sold in the open market and the other half placed in cold storage. Three 56-pound cubical boxes were also packed from each churning; one of these boxes was shipped to London, England, one to Liverpool and one to Manchester, for the purpose of having the best English experts score and criticize the butter. The butter sent to New York was scored before going into cold storage, and it was rescored when it came out of storage by Mr. P. H. Keiffer, who is generally recognized as an exceptionally good judge of butter. One of the authors was present in New York when this butter came out of storage. Strange to say, both the pasteurized and unpasteurized butter, after being in storage between six and seven months, came out of storage scoring as high as when they entered storage. Mr. Keiffer remarked that it was the finest lot of butter he had ever seen come out of storage at that time. No difference was found in the English market between the scores of the pasteurized and the unpasteurized product. One of the English judges scored some of this butter 100, or perfect. Hence, its excellent quality, whether pasteurized or unpasteurized, was due to the quality of the raw material used.

Cream of the character mentioned above is not available in the average creamery. Many investigations have demonstrated that pasteurization does produce butter of excellent keeping quality. In addition to this, it entirely eliminates the danger of transmitting disease to human beings or to animals. Veterinarians and scientists seem to be divided in opinion as to whether bovine tubercle bacilli can be transmitted to human beings, but the fact that tubercle bacilli have been found in a vigorous condition in butter has a tendency to create a fear in the minds of some people that such a danger exists. For this reason alone, if for no other, cream should be universally pasteurized for butter-making, especially in creameries where facilities are available for doing work of this kind. Pasteurization gives the manufacturer better control of the cream so that a more uniform quality of butter can be manufactured. The wide adoption of pasteurization in this and other countries, and the fact that

almost every city of any size requires it would seem to indicate that it should be made compulsory. Since the hand cream separator has been generally adopted on the farm, pasteurization seems more necessary than before, as the washing and cleansing of all dairy utensils, including the separator, is left to the farmers, and it is only reasonable to suppose that some of them are careless. Hence, we can see the necessity for pasteurization from a hygienic standpoint if from no other.

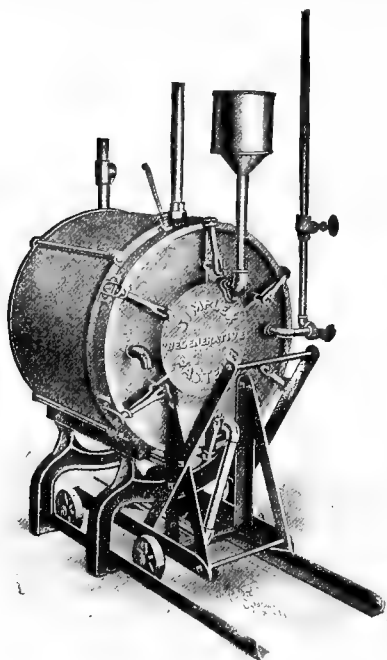

FIG. 67.—The Simplex regenerative pasteurizer (assembled)

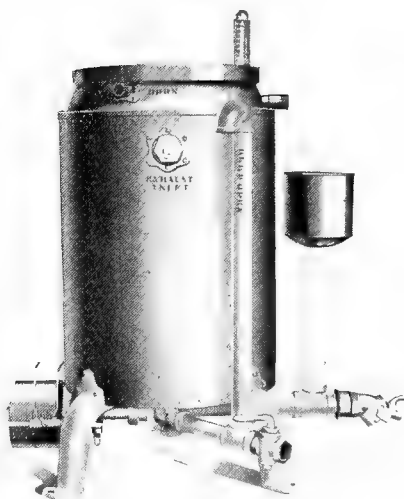

FIG. 68.—The Jensen pasteurizer.

Sanitation Must Accompany Pasteurization.—The chemical and bacteriological laboratory of the American Association of Creamery Butter Manufacturers analyzes, chemically and bacteriologically, samples of butter sent in by members. Thousands of analyses are made during the year. It is found that the butter that contains the lowest counts of yeasts and molds is invariably produced in the best creameries. Certain species of bacteria,

yeasts and molds are present in almost all hand separator cream and cause the deterioration of butter in storage; the elimination of these micro-organisms retards such deterioration. Milk or cream that is efficiently pasteurized will contain neither yeasts nor molds. In laboratory work conducted by the Association, butter in which the combined count falls below ten yeasts and molds in 1 c.c. of butter is considered good; in some of the best creameries the combined count drops to five or below. There are other things that affect the count of yeasts and molds found in butter. Pasteurization of cream may be perfect, and yet the cream may pass through unsanitary pipes and again be inoculated with yeasts or molds. Vats, faucets and churns are sources of contamination. Of the creameries sending butter to the Association laboratory, those whose butter shows the lowest count of yeasts and molds are creameries that are noted for observing extra precaution concerning sanitary methods in connection with all utensils that come in contact with cream. They use recording thermometers and automatic valves for regulating temperatures in pasteurization. The first cream passing through the pasteurizer is returned and reheated. Butter made in the creameries above-mentioned sells constantly at a premium. The quality of the cream received by them is no better than that received by other creameries operating in the same territory, which make very inferior butter.

Pasteurization expels from the cream vapors and gases, especially carbon dioxide gas; it removes volatile substances and flavors absorbed by the cream or milk. The heating causes the clusters of fat-globules to break up. Due to uniformity of quality and pasteurization, Denmark has been able to secure almost absolute control of the English market. Danish butter commonly sells at a premium over any other butter finding its way to that market, or at least it did prior to the war.

One of the authors in discussing this subject with an English merchant, who handled a great deal of butter, asked for an explanation of the preference given to Danish butter. He answered that they occasionally got better butter from some other countries but that it did not run uniform in quality. He

said that the Danish butter was mild in flavor and uniform in quality; in other words, it suited the trade and that was all that was wanted.

Efficient pasteurization not only enables the manufacturer to make a more uniform grade of butter, but it makes the butter-milk safe to feed to live stock, thus preventing the spread of infectious diseases. It is said by some that if pasteurization were adopted more skill would be required on the part of the butter-maker. With valves for controlling the steam pressure and the use of recording thermometers, uniform pasteurization to any desired temperature can be brought about by a maker of ordinary skill, if he applies judgment to the details of his creamery operation.

Methods of Pasteurization.—At the present time there are three methods of pasteurization employed for butter-making. The one most generally used is the flash or instantaneous heating method. Under this method the cream is heated to a high temperature, 180° or 185° F., and quickly cooled, by passing over a cooler, to ripening temperature or to churning temperature, as the case may be. In the vat, or holding, method cream is usually heated to a temperature of 150° to 160° F., held at this temperature for twenty to twenty-five minutes, and cooled to ripening or churning temperature. Some use the combined flash and holding method.

Some of the best creameries that use the flash method, or high temperatures, follow what is known as the double system of pasteurizing. Two pasteurizers are attached to each other; the cream passes to the first pasteurizer from the forewarmer, where it is heated to a temperature of about 135° or 140° F. It passes from the first to the second pasteurizer where it is heated to 185° F., or any temperature desired. The live steam is connected with the second pasteurizer, and the exhaust steam from the second pasteurizer furnishes heat for heating the cream in the first pasteurizer to 140° F., or thereabout. The heating of the cream in the first pasteurizer increases the fluidity of the cream. Hence, when it enters the second pasteurizer, the heat comes in contact with all particles of the cream, and the efficiency

of pasteurization is thereby increased. From general observation of work in many creameries belonging to the American Association of Creamery Butter Manufacturers, the authors feel safe in recommending this system.

One of the authors first saw this system in general use at the Experiment Station at Kiel, Germany, something over twenty years ago. Dr. Weigman was heating to 190° F. at that time, and claimed very satisfactory results.

The relative merits of the two systems—the vat system where the heating is done through a coil, or the use of a machine constructed exclusively for pasteurizing milk and cream—depend largely upon local conditions. If the first cost only is taken into consideration, cream can be pasteurized more cheaply under the vat system, as the heating and the cooling are done in the same vat. In a small creamery where space has to be taken into consideration, the vat system is to be recommended. Not only does it require less space but it involves less labor. The objections to the vat system are, first, that the vat is not constructed for a pasteurizer, and, second, that the wear and tear (heating and cooling, and expansion and contraction) will affect the life of the vat. These are items that must be taken into consideration when figuring the cost over a period of years. In a factory where a large volume of business is transacted, the regular pasteurizer would be preferable. It is much stronger than the vat and is constructed exclusively for the purpose of pasteurizing cream. In addition to this a greater amount of cream can be cared for in a shorter space of time. The cooling is done much more quickly where a regular cooler is used. Another advantage is that the heating and cooling are not done in the same vat, thus avoiding the expansion and contraction of the metals.

Some use the method of heating in the flash pasteurizer and cooling in a vat. This does away with the necessity for a cooler, but, as stated above, the cooling is not done as rapidly as it would be if a regular cooler were used. This system works well where the holding system is practiced and lower temperatures are used for pasteurizing. Cream can be run into the ripening vat from the flash pasteurizer, held any desired time and cooled with a coil.

Under the regenerative principle the cold cream is heated by the hot cream passing from the pasteurizer. In the outflow, hot cream is cooled by the cold cream flowing into the pasteurizer. The hot and cold cream then equalize their respective temperatures by passing in different directions. It is claimed by manufacturers of these pasteurizers that they effect a saving of 25 per cent, or more.

Most pasteurizers at the present time are constructed of heavy copper coated with tin. The heating surface of some of these pasteurizers is lined with German silver. From the standpoint of heat conductivity there is little choice between these two metals. It is a well-known fact that some metals will conduct heat better than others; the relative heat conductivities of copper and tin are .918 and .145 respectively. This means that copper will conduct heat nearly seven times as fast as tin of the same thickness, and therefore that copper might be seven times as thick as tin and still transmit as much heat as the tin. From this it can be seen that a heating wall made from copper can be increased slightly in thickness, and thus aid in stability, without affecting the degree of heat conductivity of the wall very much. The heating surface must be strong enough to withstand a slight steam pressure, otherwise the heating wall is likely to collapse or cave in, in case of slight variation in the steam pressure. It used to be a rather common occurrence for the heating walls of the pasteurizer to cave in or collapse in case of a slight variation in the steam pressure. This does not happen so often now.

The condition of the cream has some bearing on the heating surface. Sour and coagulated cream burns and adheres to a greater extent than does sweet cream. This is evidently due to the lesser fluidity of the sour cream. Where two pasteurizers are used, this tendency is overcome to a very large extent.

Efficiency of Pasteurizers.—Experiments conducted by Dr. Storch of the Royal Experiment Station, Copenhagen, Denmark, show that condensed steam offers great resistance to the transmission of heat. The comparative heat conductivities of water and copper are .0016 and .9 respectively, as found by Dr. Storch. It will thus be seen that copper is 600 times as good a conductor

of heat as water is. This would mean that a quiet layer of water 3 mm. in thickness would offer the same resistance to heat as a layer of copper 2 meters in thickness. Consequently a very thin layer of water or condensed steam on the sides of the heating wall would greatly interfere with the economic efficiency of a pasteurizer.

In order to overcome this difficulty drip-rings were circled

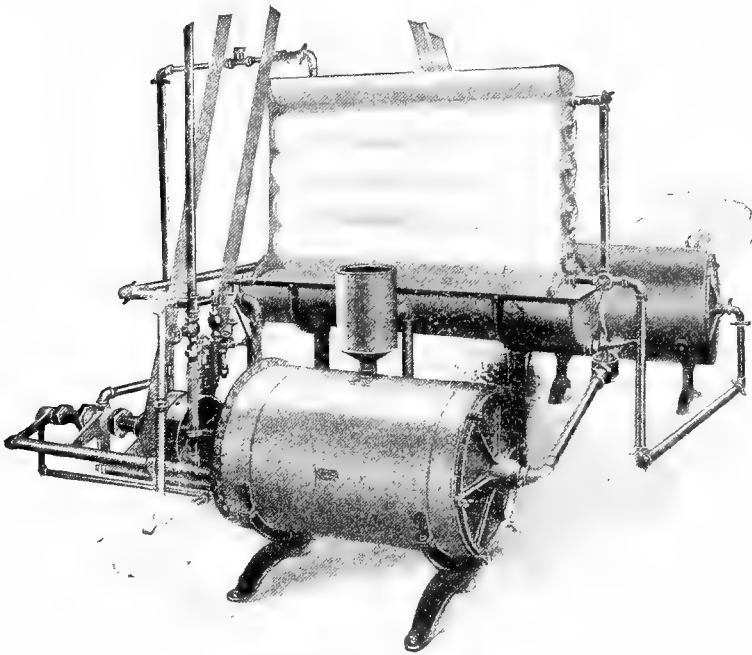

FIG. 69 -- Jensen sanitary pasteurizer-regenerator and cooler (Jensen Creamery Machinery Co.).

round the drum of the pasteurizer, at intervals, on the steam side of the heating surface. The first rings put around the pasteurizer were narrow, smooth bands. These did not give entire satisfaction, as the condensed water from the top rings would drip on the edge of the lower ones, and cause the water to spatter over the side of the heating wall. Another kind of ring was then invented which was thin, narrow, and provided with teeth like

those of a saw. The rings were fastened to the heating-wall at proper intervals at an angle of 45° . The rings were so arranged that the drops of condensed water escaping from the end of each saw-tooth would fall in the hollow between the teeth in the lower rings and thus prevent any spattering of the water against the heating wall. These contrivances greatly increased the effi-

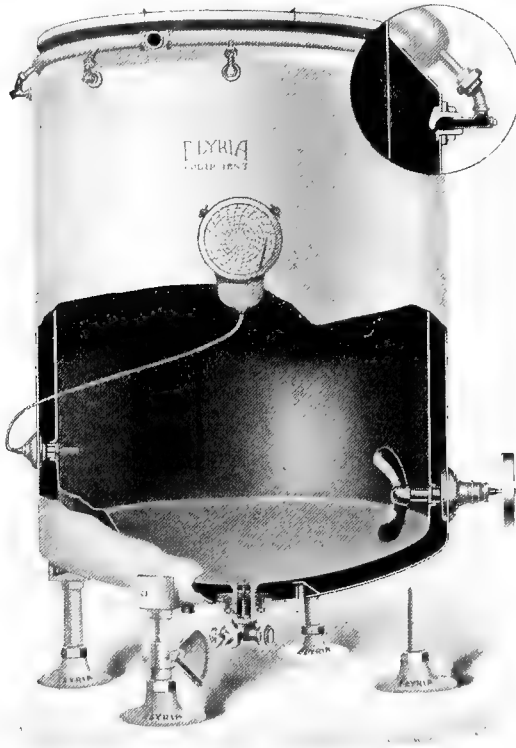

FIG. 70.—Elyria pasteurizer (Elyria Enameled Products Co.)

ciency—as much as 48 per cent—and the capacity of the pasteurizer experimented with.

Cost of Pasteurization.—Dr. Storch in his forty-third report at the Royal Experiment Station at Copenhagen, Denmark, reported that it required 80 pounds of steam to heat 1000 Danish pounds of milk from 40° C. to 85° C. This would be equivalent

under American conditions to about 90 pounds of steam to pasteurize 1000 pounds of milk from 90° F. to 185° F.

According to good authorities, it takes about 1 pound of lump coal to produce 6 pounds of steam, although much depends upon the fireman and the construction of the boiler. Based upon this estimate, it would take 15 pounds of coal to produce 90 pounds of steam. If the coal cost \$4.00 per ton, the cost of the 15 pounds would be 3 cents. If the milk tested 3.6 per cent fat, the calculation upon one-sixth overrun of 1000 pounds of milk would produce 42 pounds of butter. The cost of pasteurizing the milk producing 42 pounds of butter would then be 3 cents, and the cost of pasteurization per pound of butter would be .07 of a cent.

The figures submitted by Storch, however, were obtained a number of years ago, and cannot be applied to conditions in this country at the present time.

Mortensen, who has given a good deal of thought to the cost under the continuous and vat methods, estimates as follows:

	Continuous Method, Cents	Vat Method, Cents
Cost of steam.010	.010
Cost of water.009	.021
Cost of labor and equipment.181	.054
Total.200	.091

The cost in different factories would vary with the cost of fuel. With the high railroad rates prevailing at the present time and the high price of labor, we can estimate the cost at about one-fifth of a cent per pound.

In addition to this, the loss of fat in buttermilk seems to be a trifle more in pasteurized than in unpasteurized cream. This may be due to the precipitation of the casein by heat. Pasteurization is necessary from a hygienic standpoint. It gives a guarantee to the consuming public that all pathogenic bacteria

are destroyed. It takes away from the enemies of butter the opportunity of proclaiming that disease may be transmitted to the human family through this article of diet. There is less danger of transmitting disease through butter than through any other dairy product.

The senior author has been for more than thirty years engaged in the butter business in various capacities, from manufacturer to conductor of investigational work, and has never known of a case where any disease was transmitted through butter, from either pasteurized or raw cream. It has been demonstrated in all parts of the world that raw or unpasteurized milk will transmit bacillus typhosus. The first epidemic of typhoid fever which was traced to infected milk was one occurring at Penrith in 1858 (Taylor). Since that time cases have become so numerous that almost all municipalities insist upon efficient pasteurization of milk.

In addition to the effect that pasteurization may have on butter, pasteurization of the skim-milk and cream puts both the skim-milk and buttermilk in a condition where there is no danger of transmitting disease to animals.

Disadvantages of Pasteurization.—The disadvantages of pasteurization are, first, the cost of installing equipment, and, second, the additional cost of operation. Due to the increased cost of labor in recent years, it is difficult accurately to estimate the cost.

Advantages of Pasteurization.—The advantages of pasteurization far outweigh the disadvantages, and may be summarized as follows:

(1) It destroys pathogenic bacteria if there be any present in milk and cream, and renders them and their products and by-products perfectly safe as foods.

(2) It destroys practically all germ life and enables the butter-maker to produce a more uniform quality of butter.

(3) It is one of the large factors which improve the keeping quality of butter.

(4) It eliminates some of the taints in cream.

CHAPTER XVI

CREAM-RIPENING AND STARTERS

CREAM-RIPENING

Definition.—By cream-ripening we mean the treatment cream receives from the time it is put into the ripening-vat until it is put into the churn; and also the chemical, biological, and physical changes it undergoes during this time.

In the whole-milk creameries and in a few of the creameries receiving only cream, the cream goes into the ripening vat in the morning and no more is added during the day. In most creameries, however, cream is taken in throughout the day. This system does not permit of such perfect ripening of the cream; besides, it necessitates opening and closing the vat at intervals. Under this latter system it is important that the cream vat have a fly screen over it, and that one end of it be covered with a cream strainer through which all cream is strained before it enters the vat.

Objects of Ripening. To Produce Flavor and Aroma.

The chief object of cream-ripening is to secure the desirable and delicate flavor and aroma which are so characteristic of good butter. The necessary flavoring substances, so far as known, can only be produced by a process of fermentation. Good butter possesses two characteristic flavors. One is known as palate flavor, or the distinctive butter flavor. The other is what is described by butter judges as a nose flavor or aroma, sometimes described as "bouquet" flavor. While the flavor and aroma characteristic of good, properly ripened cream and the butter made from it are produced by fermentation, the chemical changes that produce them are not well understood. It is claimed by some that the palate flavor is derived from the volatile fatty

acids, and the aroma from a fermentation of the milk-sugar. Good cream must possess a clean, pleasant acid taste. For this reason, it is essential to have the acid-producing germs predominate during cream-ripening.

Butter has been made from sour cream from time immemorial. Housewives discovered a great many years ago that butter made from ripened cream had a more pronounced flavor and aroma than butter made from unripened cream. They also found that cream properly ripened would churn more easily and give a

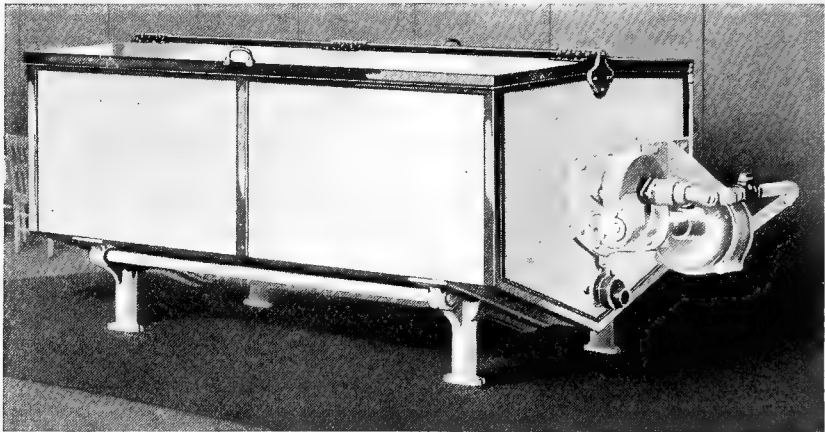

FIG. 71 — Progress vat pasteurizer and cream-ripener. (Davis-Watkins Dairymens Mfg. Co.)

more exhaustive churning; hence, the practice of souring cream has been handed down to the creameries from the home dairies. Some women became noted for making butter of an exceptionally fine quality, because, in addition to observing cleanliness as the first requisite in making good butter, they selected nice, clean-flavored milk and let it sour naturally; this was added to the cream for the purpose of hastening the souring or ripening. Some of these dairies produced butter which was not only of good quality but also possessed good keeping qualities.

In the early days of butter-making it was customary for some to pack their butter in glazed crocks during the latter part of May

or the first part of June, cover it with salt and hold it until the winter months, keeping it in the cellar or some other cool place until it was used up. As dairying advanced and butter began to be made on a large scale in creameries, in various countries, the bacteriologist resorted to the method of isolating certain species of bacteria for the purpose of ripening cream and producing the desired flavor.

It has not yet been proved that any particular species of bacteria is responsible for the production of fine flavor in butter. It is generally agreed that the flavoring substances developed during the ripening of cream are decomposition products of bac-

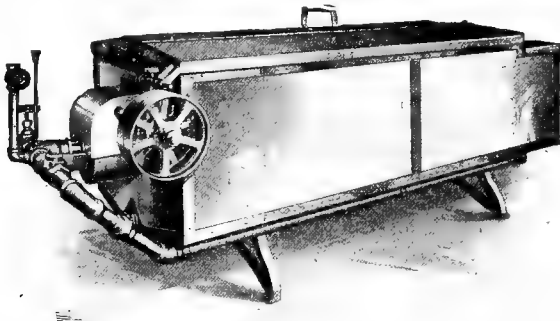

FIG. 72.—Wizard vat pasteurizer and cream-ripener. (Creamery Package Mfg. Co)

terial growth, and it has been generally recognized that the types producing the lactic acid are the most desirable ones to have present in cream. There are a great many bacteria in milk and cream which produce acid, over one hundred species have been studied and described. It is apparent, however, that only a comparatively few of these produce the best results in cream-ripening. Hence, in the preparation of a natural starter, great care should be exercised in selecting milk that will sour with a pleasant acid taste.

At the Iowa Experiment Station, McKay and Eckles conducted a series of tests on fermentation by taking milk from different patrons' herds, placing it in sterile glass bottles and allowing it to sour naturally. It was found that milk which

began to whey off at the bottom of the jar, soon after coagulation, due to certain species of bacteria decomposing the casein, invariably possessed an undesirable flavor. Samples of milk which would remain coagulated for some time and whey off at the top possessed a pleasant acid flavor. By selecting such samples of milk for preparing natural starters, these investigators were able to produce starters that gave excellent results in cream-ripening.

Butter made at the school that scored the highest at one of the large national conventions, receiving a score of 98, was made from cream that had been ripened by a natural starter. The whole milk, received at the creamery when two days old, was skimmed so as to contain a very high per cent of milk-fat. The object was to concentrate the fat and get rid of as much of the skim-milk with its undesirable bacteria as possible, and then dilute the cream with fresh milk from the herds whose milk showed desirable results when souring naturally. The addition of a starter ripened naturally from the above-mentioned milk, ripened the cream which produced the high-scoring butter.

Another test was made in a national contest where different parties were placed in charge of the ripening, taking the entire milk as it came in on four different days, and the same method was followed with correspondingly favorable results. In this contest, in which about eight hundred creameries competed, the butter made by this method, on these four different days scored the highest, third, fourth and fifth in flavor. This is a further substantiation of what has been reported by various investigators, Storch, Conn and others, that the flavor developed depends very largely upon the species of germ life that predominate.

Where cream has been pasteurized and inoculated with a starter containing the right organisms, the effects of the starter will be more pronounced than if the cream were manufactured raw or unpasteurized. This is due to the fact that the promiscuous assortment of organisms in the natural bacterial flora is largely destroyed by the heating process in pasteurization. Bacteriologists do not agree as to what species of bacteria is respon-

sible for the high flavor and aroma of butter. Conn claims that the germs which act upon the nitrogenous matter of milk are associated with the lactic-acid-producing bacteria in the production of desirable butter flavors. Weigman asserts that the best results are obtained when a variety of species work together in the cream. He has isolated a single species of germ which produces alcohol and lactic acid as by-products, and which according to experimental evidence deduced by him, is capable of producing the delicate butter flavors. Freudenreich also studied a species of germ which produced alcohol and lactic acid as by-products, and which he claimed was able to produce the

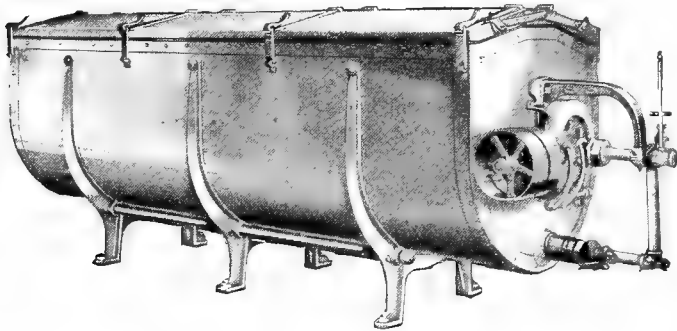

FIG. 73.—Cherry vat pasteurizer and cream-ripener (J G Cherry Co.)

characteristic butter flavors. Eckles studied the question of flavor production during cream-ripening. He came to the conclusion that the flavor and aroma substances developed during cream-ripening may be produced by a variety of acid-producing bacteria. He asserts that of the species tried the most common milk-souring organism (*Bacterium lactarii*) gave the most satisfactory results as a culture for ripening cream. Storch, who has perhaps studied this question to as great an extent as any of the investigators, maintains that the germs producing lactic acid are essential to good cream-ripening, and that the flavor and aroma products are the results of the joint action of a great many species of lactic-acid-producing germs. Tiemann finds that an addition of a small amount of hydrochloric acid to the cream does

not produce the characteristic flavor, and indicates that the process of fermentation is necessary to secure the proper flavors.

The study, by Hammer and Bailey of the Iowa Station, of the causes of flavor and aroma development in cream-ripening is briefly outlined in the section of this chapter on "Starters."



FIG. 74.—Vertical universal ripener and pasteurizer. (Jensen Creamery Machinery Co.)

This is probably the fullest investigation of this subject—in America at least—that has been conducted in recent years.

Ripening Temperature of Cream.—In regular practice the ripening temperature of cream usually ranges between 60° and 75° F. The lactic acid organisms and those associated with them

in a good starter have the greatest relative growth at 70° F., or a little above. Generally speaking, it is advisable to adopt a little lower ripening temperature in summer than in winter. For one thing, the cream has a tendency to rise a little in temperature in summer and to fall a little in winter, during the time of ripening; and furthermore, the natural bacterial flora present in summer are more favorable to cream-ripening than those present in winter. With the necessary modifications to meet conditions, 65° to 70° will be found a suitable range of temperature to adopt during the summer season and 70° to 74° during the fall and winter months. The amount of starter used and the length of the ripening period are factors that must be considered in deciding upon the temperature to be used. Where a fairly high ripening temperature is adopted a little greater precaution must be taken to prevent over-ripening of the cream, particularly if a liberal amount of a good, active starter be used.

Amount of Starter to Add to Cream.—The amount of starter to add, the ripening temperature and the length of the ripening period are related factors that influence each other. Also the richness of the cream places a limit upon the amount of starter that can be used. Generally speaking, where the separating is done on the farm the richness of a vat of cream is not so great as where the milk is delivered to and separated at the creamery, and consequently it is not practicable to use so high a per cent of starter in the former as in the latter case. The quantity of starter used will range from 10 to 20 per cent, depending upon the ripening temperature adopted, the richness of the cream, the time within which the ripening is to be done, and, to some extent, the cost of the milk or skim-milk used in making the starter.

Mixing the Starter with the Cream.—When the starter is added to a vat of cream the coils should be run for a few minutes in order to mix the two very thoroughly. This is necessary to insure uniformity of ripening.

Tests for Acidity.—The acid in cream is developed in the milk-serum, and the per cent of butter-fat that cream contains merely takes up space. Hence, in ripening cream some consideration should be given to the per cent of fat in it, as the fat is a neutral

quantity. For instance, it is not safe to develop as high a per cent of acid in cream containing 40 per cent as could be developed in cream containing 25 or 30 per cent of fat. For this and other reasons it is advisable to use a special test with which to measure the amount of acid developed in the cream. There are two acid tests in general use now in creameries, viz., "Mann's Test" and the "Farrington Test."

Mann's Test.—Mann's test consists of measuring the acid in

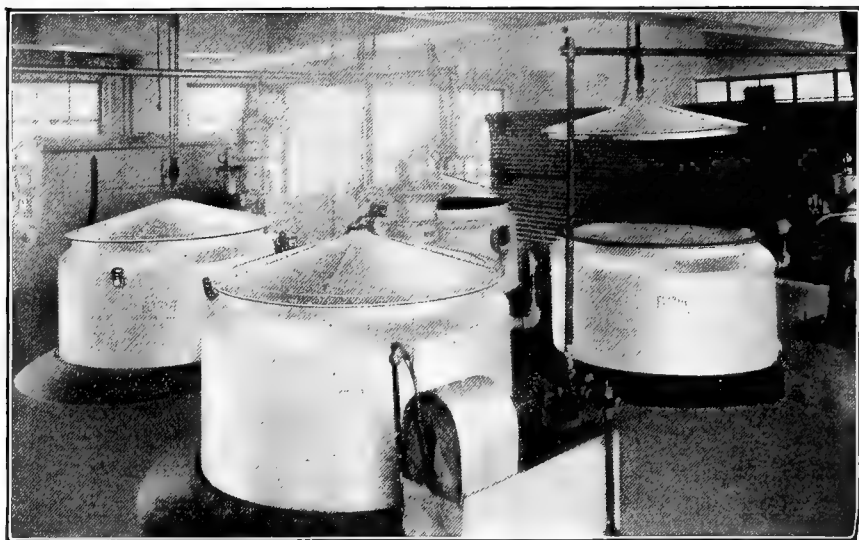

FIG. 75.—A creamery equipped with glass enameled tanks and vats.

the cream by means of an alkali of a definite strength. The kind of alkali used is usually a tenth normal solution of caustic potash (KOH) or caustic soda (NaOH). These solutions can be made up very cheaply or bought from the supply houses. Mann's test is based upon measuring out 50 c.c. of cream by means of a pipette. While the test is based on 50 c.c. of cream a 25 c.c. pipette can be used, and the reading multiplied by two, thus avoiding the necessity of using so much cream. Even a smaller pipette could be used, but 25 c.c. is preferable to a smaller quantity, which would increase the danger of error. A few drops of an

indicator (phenolphthalein) are added. This indicator gives a red color in an alkaline solution, and no color in an acid solution. The tenth normal alkali solution is poured into a burette, and allowed to run into the 50 c.c. or 25 c.c. of cream (which is kept stirred thoroughly) until it begins to turn pink in color. At this point it is neutral. The number of cubic centimeters of alkali required to neutralize the acid in 50 c.c. of cream indicates the number of degrees of acid. For instance, if it should require 32 c.c. of a tenth normal alkali to neutralize the acid in 50 c.c. of cream, the acidity of the cream would be 32° . (1 c.c. of N/10 alkali = 1° Mann's Test.)

Mann's test reading can be converted so as to express the results in percentage similar to the Farrington test. As 1 c.c. of the tenth normal alkali neutralizes .009 gram of pure lactic acid, 32 c.c., as in the above case, would neutralize 32 times .009. This would give the amount of acid, calculated in terms of lactic acid, present in the 50 c.c. of cream. This product divided by the 50, and multiplied by 100, would give the percentage of the acid present.

Farrington Test.—The same principle is involved in the Farrington test. The alkali is put up in small tablets, already containing the indicator. These tablets contain a definite amount of alkali, and are represented as retaining their strength. They lose it, however, if they are exposed to the atmosphere. The amount of alkali in each tablet is such that when five of them are put into a graduated cylinder, the cylinder filled up with distilled water to the 97 c.c. mark, and the tablets thoroughly dissolved in it, a solution is obtained, each cubic centimeter of which represents .01 of 1 per cent of acid, provided 17.6 c.c. of cream are taken. The tablets can be made up of different

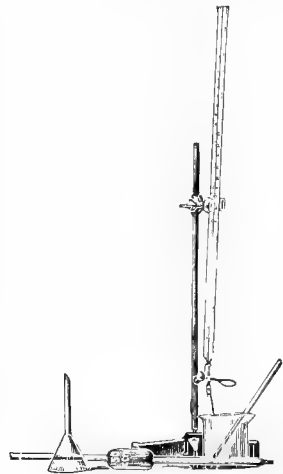

FIG. 76.—Apparatus for Mann's acid test. Instead of the burette the alkali can be kept in a large bottle, as shown in Figs 77 and 78.

strengths for the use of different-sized pipettes, but as the 17.6 c.c. pipette is the one which is used in the ordinary Babcock test, directions are given for the use of this pipette only. For a more detailed description of the acid tests see "Testing Milk and its Products," by Farrington and Woll.

Degree of Acidity that Cream Should be Ripened to.—As to

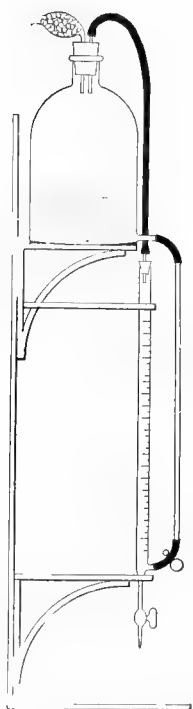

FIG. 77.—Arrangement for keeping alkali for the Mann's test.

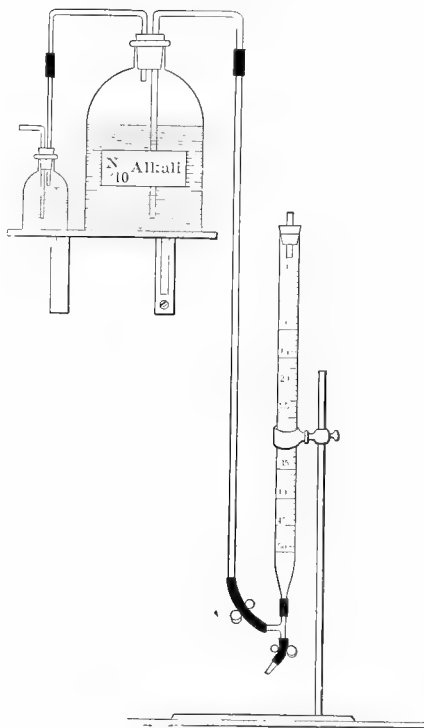

FIG. 78.

the per cent of acid that should be developed in cream, this will depend upon such factors as the richness of the cream, the market demands as to fullness of flavor in the butter, whether the cream is sweet cream or cream that has previously soured and been neutralized, and the length of time the butter is likely to be held in storage.

As has already been pointed out, rich cream should not show as high a per cent of acid when ripened as cream with a lower fat-content. If it should do so it is really a riper cream, that is, the skim-milk portion of it has been ripened to a higher degree of acidity.

Where cream has soured and been neutralized before pasteurization, it is advisable not to ripen to as high a degree of acidity as might be developed were the cream sweet to begin

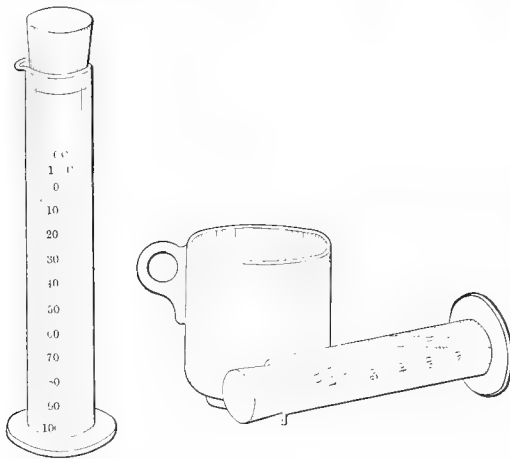

FIG. 70.—Apparatus for the Farrington acid test.

with. Especially does this apply when butter is likely to be held any length of time.

Unless market conditions demand it—and it is only in very exceptional cases that they do—it is not advisable to ripen average cream, or cream with a fat-content of about 30 per cent to an acidity of over .50 to .55 per cent. It is safer to err a trifle on the side of underripening rather than to overripen cream.

STARTERS

Definition.—By the term starter, in cream-ripening, we understand a medium containing a preponderance of desirable germs present in a vigorous condition.

History.—The use of starters in the dairy industry dates back a great many years. The fact that starters helped in the manufacture of dairy products was recognized years ago by practical men even before scientists recommended the use of pure cultures. In European dairy countries the use of the buttermilk borrowed from a neighboring factory to add to the cream in order to overcome abnormal conditions, was a common occurrence. In Holland, sour whey borrowed from some other factory was used to overcome gassy fermentation in cheese-making. While the reasons for this were not well understood, the underlying principle involved was that of overcoming the undesirable fermentation by adding ferments of an antagonistic kind.

The introduction of commercial starters for cream-ripening dates back to 1890, when Professor Storch recommended their use in creameries in Denmark. After commercial starters had been used long enough in that country to demonstrate their worth, they were introduced into this as well as practically all the European countries, and are now used quite extensively.

Classification of Starters.—Generally speaking, the different kinds of starters are included under the names (1) Natural, and (2) Commercial. The latter are prepared from a culture of bacteria obtained from the laboratory. The former, or natural, include a great many kinds of dairy products which are supposed to contain a preponderance of those germs which are involved in the production of desirable flavors in butter. Buttermilk, sour cream, whey, and sour whole or skim-milk, are classed under this heading. While all these may be termed natural starters, and at certain times the use of any one of them may produce better results than if no starter at all were used, it is not safe to rely upon them to bring about better results than could be obtained without the use of starters, because these products are likely to be contaminated in a large degree with undesirable germs.

Preparation of Natural Starters.—The best natural starter is usually obtained by selecting a number of different samples of the best milk coming into the creamery and putting them

into cleaned sterile glass jars. The samples are allowed to stand until sour at about 70° F. The sample which coagulates into a smooth uniform curd, and has a pleasant acid taste and smell is selected and used as a mother-starter. When a large quantity of selected pasteurized milk or skim-milk is inoculated with this and cooled to and held at a temperature of about 70° F., until it begins to coagulate, it will usually prove to be a starter which is equal, and often superior, to a commercial starter.

Commercial Starters or Cultures.—Experiments have amply proved that certain species of bacteria are chiefly responsible for the butter flavors developed in cream during ripening. This fact has given rise to the use of cultures prepared in a commercial way. These cultures contain, in a vigorous condition, the germs which produce the desirable flavors and aroma. The cultures are put up in laboratories specially provided for this kind of work. Some of the laboratories put these cultures up in liquid form while others put them up in a dry or powder form. The liquid starters consist of a sterile nutrient medium, milk or beef broth, inoculated with the culture; while the starters in dry or powder form are prepared by mixing the liquid culture with some suitable substance, such as milk-sugar, and drying this mixture at a temperature low enough not to injure the germs present in it. The cultures that are put up in the liquid form will not keep so long, and it is not safe to use them after they are about nine days old. The cultures which are put up in powder form have the advantage that they can be kept for a much longer time and still retain their vitality. Both kinds as a rule are good while they are fresh. We give a list on next page of the commercial cultures with which the authors are familiar.

Technically speaking, most of the commercial cultures sent out from the different laboratories, to be used in the preparation of starters for milk- and cream-ripening, are not pure cultures of lactic acid organisms, although they are commonly spoken of as such. A pure culture is one which contains just a single species of organism, and most of these cultures contain more than one. The commercial cultures are, however, limited as to variety of species contained—usually two and at most three—and do not

contain a promiscuous variety of organisms. It is for this reason that they are commonly designated as pure cultures.

Commercial Starters	American	S. C. Keith, Charlestown, Mass.	} Lactic Acid Culture } Duplex Culture } Boston Butter Culture	} Liquid
		O. Douglas, Boston, Mass	} Boston Butter Culture } Duplex Culture } Lactic Acid Culture	} Liquid
		Elov Ericsson, St. Paul, Minn.	} Ericsson's Butter Cul- } ture	} Liquid } and } Powder
		Chr. Hansen's Lab- oratory, Little Falls, N. Y.	} Lactic Ferment	} Powder
		Parke, Davis & Co., Detroit, Mich.	} Flavorone	} { This culture is put } up in tablet and } capsule forms
	Foreign	Blauenfeldt & Tvede, Copen- hagen, Den.	} Danish Lactic } Acid Ferment	} Powder
		Hjort & Fog's Laboratory Cul. Copenhagen, Den.	} Lactic	
		S. P. Storm, Tillitze, Naks- kov, Den.	} Starter	

Extensive work done by Hammer and Bailey of the Iowa Station not only supports what has just been said regarding commercial cultures, but also goes to prove that while the organism which predominates in a good culture or starter is the common lactic acid organism (*Streptococcus lacticus*), there must also be associated with this, an organism or organisms, which will develop volatile flavor and aroma-producing acids. Hammer says that it seems that there is no longer any question that starters are mixed cultures, and that even a pure lactic acid culture sent out from a laboratory very soon becomes a mixed culture containing volatile acid-producing organisms. These findings by Hammer and Bailey are supported by the work done by Storch in Denmark, and Beckout and Ott de Vries in Holland.

According to Hammer, the lactic acid, which is non-volatile, produces an acid flavor but very little of the flavor and aroma so characteristic of a good, well-ripened cream and the butter made from it. The organisms which he has found to be the most suitable associate organisms of the lactic acid organism (*Streptococcus lacticus*) are *Streptococcus citrovorus* and *Streptococcus paracitrovorus*. *S. citrovorus* acts upon the citric acid of milk and cream (hence its name), and also to a certain extent upon the lactic acid, and converts these into volatile, flavor- and aroma-producing acids. *S. paracitrovorus*, in addition to performing the same function, also develops and uses another product.

A good starter is one which will develop a fair proportion of the volatile, flavor- and aroma-producing acids without the development of an excess of acidity; that is, it will afford all the advantages to be gained from the proper ripening of cream without the disadvantages that come from ripening it to too high a degree of acidity. The great problem is that of the maintenance of a proper balance between the lactic acid organism (*S. lacticus*) and the associate organism or organisms which develop the volatile, flavor- and aroma-producing acids. One of the large factors in maintaining this balance is a proper ripening temperature in both starter- and cream-ripening. Hammer mentions 70-72° F. as a very favorable range. A temperature much above this is more favorable to *S. lacticus* than to *S. citrovorus*, that is, it will enhance the development of lactic acid to a greater extent than that of the flavor- and aroma-producing acids, and throw the ripening out of balance.

It would seem then that the big problem for our laboratories, in the preparation of commercial cultures, is to supply a culture which, if properly handled in the creamery, will develop a reasonable amount of suitable, volatile flavor- and aroma-producing acids without the development of excessive acidity in the cream; and that one of the large problems for the creameryman is proper temperature control in both starter and cream-ripening, so as to enable flavor production to keep pace with lactic acid production. It would seem to be quite a safe practice to ripen the cream at a temperature of 70° F., provided care is taken to cool

it early enough to prevent the development of acidity from going too far. Under the varying conditions that exist in the different creameries each creameryman will have to decide for himself the temperatures that best suit his conditions. What the authors have aimed to do is to state the underlying principles of successful starter and cream-ripening, and what they would urge most is the intelligent application of these principles.

Preparation of Commercial Starters.—All of the starters mentioned above have been tested and are known to produce good results. The first step in the preparation of a mother-starter (starterline) is to prepare preferably a glass jar or bottle by thoroughly cleaning and sterilizing it. Glass jars are used in preference to any other vessel, because if they are unclean in any way, it will be apparent. Secondly, there are no seams and no places on the inside which will corrode, and in that way retain unnoticeable dirt; and in the third place, the nature of the coagulation can be readily observed through the glass. Mason jars and sampling bottles are suitable. The kind of bottle which is used for marketing milk gives very good results.

The second step consists in selecting suitable milk. The milk must be in as pure and sweet a condition as possible. A good starter can be produced from either whole or skim-milk. At one time skim-milk was given a decided preference for use in the making of starters. But the views of some of our leading bacteriologists and practical creamerymen, experienced in the preparation and use of starters, have changed upon this point and they now express a decided preference for the use of whole milk starters. The reasons for this preference may be briefly stated: The whole milk is generally more easily selected; it is the practice in some of our best creameries to have some farmer supply milk, produced under special sanitary conditions and cooled promptly to a low temperature, for starter purposes. The trouble of separating and a possible extra source of contamination are avoided. The presence of the fat in the milk serves two useful purposes; first, the cream that rises seals the starter over and prevents contamination, and second, the exclusion of

air prevents the development of certain injurious organisms, which may be present and which require air for growth.

However, fine starters can be made from either whole milk or skim-milk, and the point of first importance is that the milk used be sweet and in a clean, sanitary condition.

The milk which has been selected for the mother-starter, or starterline, is then pasteurized. The pasteurization is best accomplished by the intermittent method. If considerable milk is to be pasteurized it is best to make use of a clean, sterilized starter can. If only a small portion is to be pasteurized, just enough for the mother-starter, the milk can be put directly into the jars. The jar half full is about the proper amount of milk to use. The directions sent with some pure cultures recommend as much as half a gallon or a whole gallon of milk. As a rule better results are obtained if only about a pint of milk is taken. If the milk for the mother-starter is pasteurized in the glass bottles

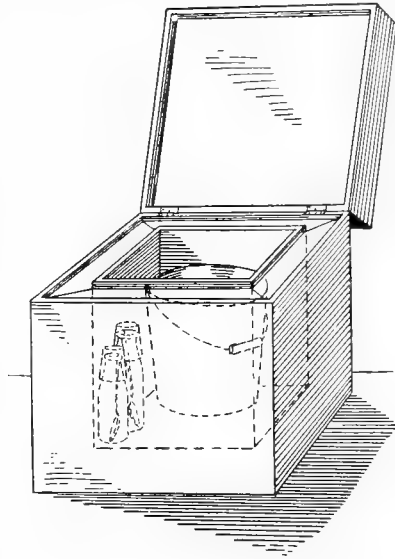

FIG. 80.—An Incubating Chamber for Starters. The inner compartment will hold a pail of water and the bottles for the mother-starters. The temperature can be kept at any desired point by the use of warm or cold water. The four-inch space between the walls is filled with hay or mineral wool. (Dairy Bacteriology, Russell and Hastings.)

or jars, it is advisable to set the bottles containing the milk into cold water,—covering the jar so as to prevent outside contamination,—and then heat up the water gradually. Care should be taken not to insert these bottles suddenly into scalding hot water, or to let the steam strike them, for either is likely to crack the bottles. Care should be taken also to exclude water from milk used for starters. It is advisable to heat this milk, for

the starterline, as high as possible in hot water, say up to about 200° F. The sample may assume a cooked taste, but this will soon disappear after the starter has been carried on a few days. The milk should be left at this high temperature for about ten or fifteen minutes. A longer time does no harm. Then the milk is gradually cooled to about 80° F. This high temperature is desirable, because the germs present in the commercial culture may be somewhat dormant. This high temperature would tend to revive them more quickly than a lower temperature. Great care should always be taken to cool the milk previous to inoculating it with the pure culture, otherwise the germs present in the culture will be destroyed.

Inoculation.—The next step is to inoculate the prepared milk with the culture obtained from the laboratory. The bottle which contains the culture is carefully opened, turned over and emptied into the pasteurized milk. It should be held down closely to the mouth of the jar containing the sterile milk, in order to prevent, as far as possible, the entrance of the air and the consequent danger of contamination. Then the milk containing the culture is thoroughly stirred and set away in a room where the temperature is about 70° F. This will gradually cool the milk from 80° to 70° F., and in about twenty to forty hours the milk will sour and coagulate. Germs in nearly all of the liquid cultures are rather slow in acting upon the milk, undoubtedly due to the dormancy of the germs, and to a comparatively few of them being present in the culture. When the powdered cultures are used, a little more care is essential to get the powder thoroughly mingled with the milk. It is a trifle more difficult to get the powder thoroughly mixed with the milk than it is to get the liquid cultures mixed. If anything is used with which to stir the sample, it should be sterilized before coming in contact with the milk. This applies in the preparation of all cultures. In testing or sampling the mother-starter, nothing should be allowed to come in contact with it unless it has previously been thoroughly sterilized. The powder cultures are usually more vigorous in their effect than most of the liquid cultures now on the market. The powder cultures usually

coagulate the sample in about twenty-four hours, and if the operator is used to handling the liquid cultures, he should watch the mother-starters prepared from powder cultures, so that they do not get overripe. It is very essential that this should not happen. The time when the germs are most numerous and most active in the starter is about the time when the sample coagulates. As soon as this stage has been reached, or just previous to coagulation, the starter should be cooled down to at least 50° F., or lower if possible. This prevents any further growth of germs and the sample can thus be kept a short time without injury.

Directions usually accompany each of the cultures, but the above will be found to produce good results with all of those mentioned in the above list.

By putting from 2 per cent to 5 per cent or more of the mother-starter into a large sample of pasteurized milk, any desired amount of starter can be prepared. In selecting this amount of milk, as much care as possible should be taken in order to select the best kind of milk, and keep it from being contaminated. When this large sample of starter is at the proper stage of coagulation, it should be used at once, or else cooled down to about 50° F. The amount of mother-starter with which to inoculate the large sample of starter may vary a little without any bad effects. If the large sample of starter is to be ready for use in a short time, a larger portion of the mother-starter can be used for inoculation. If the temperature at which the starter is set and the amount of mother-starter used for inoculation are the same from day to day, the starter will be ripe at nearly the same hour every day, and, consequently, more uniform ripening results can be obtained. The noticeable coagulation of the starter when milk or skim-milk is used will usually take place when there is about .6 per cent of acidity. A slight coagulation will take place when there is about .5 per cent of acidity, but it is hardly noticeable. The coagulation-point may vary with different samples of milk.

If a mother-starter is to be kept any length of time it should be inoculated into a sample of good fresh pasteurized milk about

every other day. If a mother-starter, or starter of any kind, is allowed to stand too long at a low temperature, the desirable germs will become dormant, and some undesirable germs will gradually gain a foothold. It is a good plan to carry any mother-starter along for two or three days before it is used to inoculate a large sample of milk. When the mother-starter is first prepared it sometimes possesses an undesirable taste and smell from the medium in which the germs were put up at the laboratory. This smell and taste are eliminated by carrying it on two or three days previous to its use.

After inoculation and the proper mixing of the mother-culture with it, a new starter should not be disturbed during the ripening process. A good starter, when ready for use, will have a soft, close coagulation, without any gas openings or wheying off (particularly at the bottom); it will, when mixed, break up readily and form a smooth, creamy liquid entirely free of lumps, and will possess a pleasant acid taste and a characteristic aroma that is delicate and agreeable.

It is of vital importance that a starter be prepared and kept in specially sanitary surroundings. While not absolutely essential, it is advisable, if possible, to have a small room, suitably constructed and equipped, as a starter room. The chief equipment of such a room would consist of,

(1) Quart sealers or bottles in which to prepare the mother-culture from day to day.

(2) A small galvanized iron tank or box in which to sterilize bottles, thermometers, dippers, etc. It should have water and steam connections.

(3) A small incubating chamber in which to keep the mother-starters. This is a small insulated box or chamber lined with galvanized iron and well insulated so that the temperature can be kept at any point desired.

(4) A suitable starter can, one of suitable size, in which heating and cooling can be accomplished readily, and which is well insulated so as to hold temperature.

One of our largest creamery companies, a company whose butter has won an enviable reputation in the New York and other

eastern markets, follows a system of handling and ripening cream, in all of its creameries, which is worthy of consideration. The acidity of the cream is reduced to about 15° Mann's Test (.27 per cent) for pasteurization, milk of lime being the neutralizer used. The cream is then pasteurized at a high temperature, 180° to 185° F., after which it is promptly cooled to ripening temperature. Before adding the starter the acidity is further reduced to 5° to 8°, Mann's (.09 to .14 per cent), if it has not already fallen to this during pasteurization. If there be any probability of trouble with metallic flavor the acidity is reduced still lower—to 2° or 3°, Mann's test (.04 or .05 per cent). A carefully prepared starter, which is active and possesses a desirable, clean flavor, is then added, and the cream is ripened and held overnight. The aim, in ripening the cream, is to develop an acidity of about 30° Mann's (.50 to .55 per cent) for churning.

Great care is exercised in connection with the raw material and the preparation and use of the starter, and equal care is taken to avoid subsequent contamination of the cream, due to faulty or unclean pipes or utensils. As to the raw material for the starter, the practice is to arrange with some farmer to supply milk produced under special sanitary conditions, and promptly cooled and held at a low temperature until shipped. A special room is fitted up as a starter-room and this is placed in the charge of a man skilled in the preparation and use of starters.

The butter made from cream, handled and ripened as indicated, possesses not only a fine, full flavor and aroma when made, but good keeping qualities as well. The butter made by this company commonly sells at a substantial premium over Extras and Specials.

Milk Powder for Starters.—According to experiments conducted at the South Dakota Experiment Station, Bul. 123, milk powder solutions may be successfully used instead of the natural milk for starters.

In many large central creameries, skim-milk is difficult to obtain. In such places milk powder can be and is successfully used.

Milk powder is of about the same consistency as flour and

dissolves in cold water with similar difficulty. To make the milk powder dissolve as quickly as possible, weigh out the required amount of water into the starter can. Turn the steam on and heat. While the water is heating weigh out the required amount of milk powder. Use powder at the rate of 3 ounces to 1 quart of water. Add the milk powder to the water and stir violently. If little lumps remain stir every five or ten minutes during heating. Continue to heat or pasteurize as though it were normal milk. The remainder of the processes involved in making this into a starter are the same as already described.

Length of Time a Starter Can be Carried.—In this country, even if special precautions are taken, it seems almost impossible to carry on a starter for more than four weeks without having undesirable ferments enter. The length of time a starter can be carried undoubtedly depends upon conditions, and the care with which it has been handled. When a starter is properly prepared, cooled gradually before coagulation, and not over-ripened, it will contain a smooth soft curd, and retain its mild acid flavor for at least a month. The Danes, who use starters in butter-making more regularly than any other people, are able to carry a starter along for six months or more without renewing it.

It is a good plan to keep at least two different kinds of starter by carrying them on from day to day in small quart jars. Then if one should happen to "go off," the other one can be used instead.

Poor Starters.—Many unsuccessful results from the use of starters for cream-ripening have been reported. The failure can be traced to the improper use of starters. If starters are good they will never bring about poorer results than are obtained without the use of them. Owing to the fact that it is difficult to keep the same starter in a good condition very long, many starters are used which develop abnormal fermentations in cream. A slightly acid, somewhat bitter taste, and a slimy condition of the starter are defects which are very common. These conditions seem to be brought about chiefly by overripening it at a high temperature, and keeping it a long time at a low temperature before using it. Slimy fermentation is very common in starters which have been carried on for a time. Whenever this

slimy ferment develops in the starter it can be noticed both in the cream and in the starter by the failure of the acid to develop so rapidly as when the proper acid-producing ferment is present. It seems almost impossible to develop any more than about .5 per cent of acidity in 30 per cent cream, while if the proper ferment were present, about .7 per cent could be developed. A decrease in the quality of butter accompanies the development of this ferment in the cream.

Whenever it is found that a starter is not in good condition, it should not be used, as a poor starter is worse than none at all. The buttermilk from the previous cream can sometimes be used advantageously until a new starter can be prepared.

Underripening and Overripening of Starters.—The effect of overripening starters has already been mentioned under the "Preparation of Mother-starters." The question of underripening starters is also of importance. It is a well-known fact that just about the time when the milk begins to turn sour, that is, when the sourness can just be recognized by the taste, it has a rather disagreeable flavor. After more acid develops the undesirable flavor largely disappears, and the milk assumes a clean, desirable acid taste. The reasons for this have been stated by Storch, the well-known authority on starters. He claims that this disagreeable flavor is due to the action of undesirable organisms, during the first souring stage. As the souring progresses these germs are subdued and gradually crowded out by the desirable acid-producing types.

In the preparation of a starter the probabilities are that some of these undesirable types of germs are present. At least it is safer to go on the assumption that they are present. This makes the underripening of starters just as important to guard against as overripening.

Amount of Starter to Use.—The amount of starter will vary under different conditions. It may vary from none at all to as much as 50 per cent of the cream to be ripened. The quality of cream is one of the factors that need to be considered. Raw cream and old cream both require a large starter, especially if the cream is thick enough to permit of being reduced in thick-

ness. Good pasteurized cream does not need a larger starter than about 10 per cent of the cream to be ripened.

The amount of starter to use also depends somewhat upon the general creamery conditions. In some creameries all the cream is received in a very sour and poor condition, and facilities for getting milk for preparation of starters are often very poor. Under such conditions it is questionable whether it would be profitable to use starters at all. The amount of starter to use chiefly depends upon the degree of rapidity of ripening desired, and upon the temperature of the cream. If it is desirable to ripen quickly, a comparatively large amount of starter (15 per cent to 25 per cent) should be added, and the ripening temperature should be comparatively high (about 70° to 74° F.) If slow ripening is desired, less starter may be used. Enough, however, should be used to control the fermentation in the cream (about 10 per cent to 15 per cent), and the ripening temperature may be lower, between 60° and 70° F. More starter should be used in the winter.

Use of Starter-cans.—In the past, ordinary tin shot-gun cans have been used in most cases for the preparation of starters, and have given good results. Some makers still use such cans.

The earliest starter-cans were made of light material and did not last long. These defects, however, have largely been done away with, and the use of starter-cans certainly is an improvement over the old method of preparing the starters in several smaller cans.



FIG. 81.—Improved Victor Starter Can. (Creamery Package Mfg. Co.)

These starter-cans are jacketed, so that the temperature can be controlled by using hot or cold water, or ice, as demanded, in the jacket. All of the starter-cans have an agitator, which is operated with a belt.

CHAPTER XVII

CHURNING AND WASHING BUTTER

Definition.—By churning we understand the agitation of cream to such an extent as to bring the fat-globules together into masses of butter of such size as to enable the maker to separate them from the buttermilk.

The agitation may be brought about in several different ways,



FIG. 82.—Ancient method of churning
in skin bags.

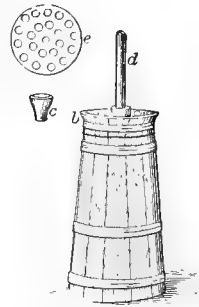

FIG. 83.—The Dash churn.

and by different shaped devices, which are called churns. The methods of churning, like the process of separation, began with primitive methods. The ancients churned their milk, without separation, in bags made from the skins of animals. The next step in advance was to place milk or cream in bottles or jars, and then to shake them. This latter method of churning cream in bottles is yet in use in many of the smaller households of Europe, where the amount of cream is limited to a small quantity donated

by cow-owners. The next step toward churning on a large scale was to get a large wooden box or barrel run by power or by hand. The churns which are in use at the present time in American butter-factories are termed "combined churns." They are so arranged as to admit of churning, washing, salting, and working without removing the butter from the churn. This style of churn is now being introduced into Europe. Owing to their superior worth they will soon be in general use there as well as here. They keep flies away from the butter during fly time; the temperature of the butter can be controlled in the churn, and the handling of the butter during salting and working is obviated.

CONDITIONS AFFECTING THE CHURNABILITY OF CREAM

Temperature.—The temperature of cream is one of the most influential factors in determining its churnability. The higher

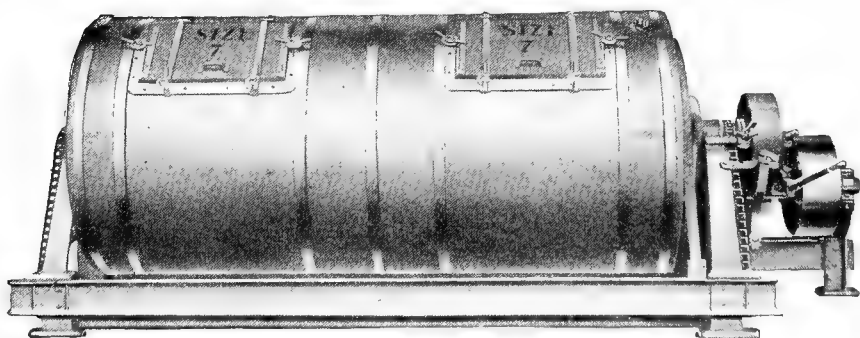

FIG. 84. - Dual Churn (Creamery Package Mfg. Co.)

the temperature of the cream, the sooner the churning process will be completed. Too high a churning temperature, however, is not desirable. It causes the butter to come in soft lumps instead of in a flaky granular form. This is deleterious to the quality of the butter. It causes, first, a greasy texture of the butter, and, second, the incorporation in the butter of too much buttermilk. This buttermilk contains sugar, curd, and water,

which, when present together in butter, are likely to sour and in other ways injure the butter. Curd and sugar should be excluded from butter as much as possible, in order to eliminate food for bacteria which may be present. An excess of curd is also favorable to the formation of mottles.¹

Too low a temperature is also undesirable, although it is better to have the temperature a little low rather than too high. When the churning temperature is too low, difficult churning is likely to occur. Cream at a low temperature becomes more viscous. On agitation in the churn such cream, if it is very thick, will adhere to the sides of the churn and rotate with it without agitating; consequently no churning will take place. Too low a temperature brings the butter in such a firm condition that it takes up salt with difficulty, and when this hard

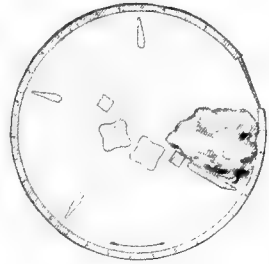

FIG. 85.—Sectional view of Dual.

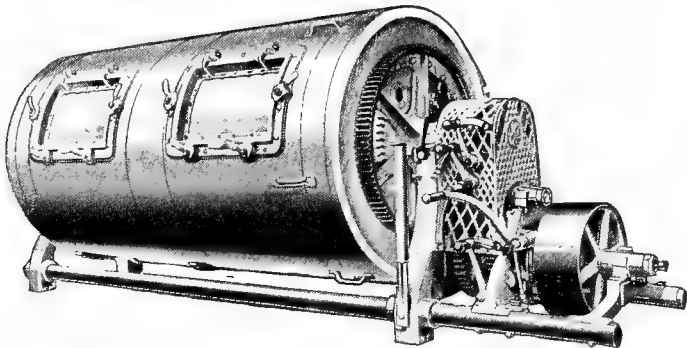

FIG. 86.—Perfection Dreadnaught Churn (J. A. Cherry Co.)

butter is being worked, a large portion of the water in the butter is expressed, and the overrun will be lessened to a great extent without increasing the commercial value of the butter.

The degree of hardness of the fat in the cream is the governing factor in deciding the churning temperature. The churning

¹ Bul. No. 263, Geneva, N. Y.

temperature will vary a great deal in different localities. The hardness of the fat depends upon (1) the season of the year; (2) the individuality of cow; (3) the stage of lactation; and (4) the kind of food fed to the cows. All these factors influence the



FIG. 87.—Sectional view of Perfection working butter.

melting-point of butter-fat. The higher the melting-point of the butter-fat is, the higher the churning temperature, and the lower the melting-point of the fat, the lower the churning temperature.

1. During the spring the cows yield milk containing a larger proportion of soft fats; consequently the churning temperature is always lower in the spring than in the fall or winter. During winter, when the cows are fed on dry food chiefly, the harder fats increase in quantity, and consequently a higher churning temperature is necessary during that time.

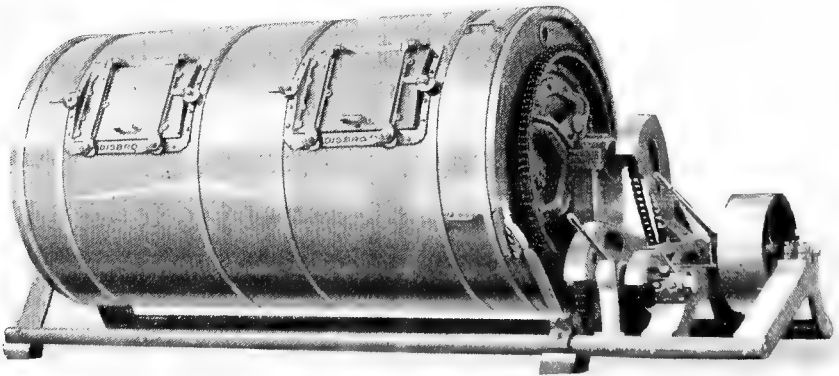

FIG. 88. Disbrow churn (Davis-Watkins Dairymen's Mfg. Co.)

2. Some animals produce milk containing a larger proportion of softer fats than do other animals. It is said that the difference in this respect is more marked in certain breeds. It is maintained that the cows of the Jersey breed produce milk

containing a larger proportion of the softer fats than do those of any of the other breeds.

3. The period of lactation also affects the melting-point of butter-fat. When a cow is fresh she yields a larger proportion of the soft fats than she does later on in the lactation period. Just how much this change in the hardness of the fat is due to advance in the lactation period and how much to change from succulent to dry feeds is not definitely known, since the two parallel each other so closely, it being the common practice in this country to have the cows freshen in the spring. According to

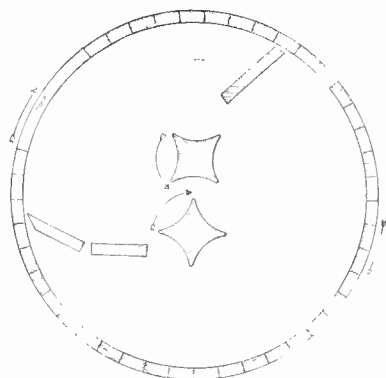

FIG. 80.—Sectional view of Disbrow.

investigations conducted at the Purdue Station,¹ the melting point of the fat lowers as a cow advances in her lactation period, provided she is fed the same feeds throughout the year. If these findings be correct, they mean that the influence of the feed is much greater than that of the stage of lactation, since the broad truth still remains, that under our conditions the proportion of hard fats increases as the lactation period advances. With this increase in the proportion of the hard fats in the advancement of the lactation period, the fat-globules become smaller. This, together with the increased hardness of the fat, causes difficult churning at times. It readily can be seen that the larger the fat-globules are the greater are the chances for these globules to strike each other during agitation in the churning process.

4. The nature of the food fed affects the melting-point of butter to a considerable extent. Cotton-seed and its by-products have been demonstrated thoroughly by several investigators to cause butter to become hard. When a large amount of cotton-seed is fed, the butter assumes a crumbly, tallowy, hard condi-

¹ Purdue Bulletin 159

tion; while linseed meal, and practically all succulent foods, tend to decrease the melting-point of butter-fat.

According to the above it can be concluded that the churning

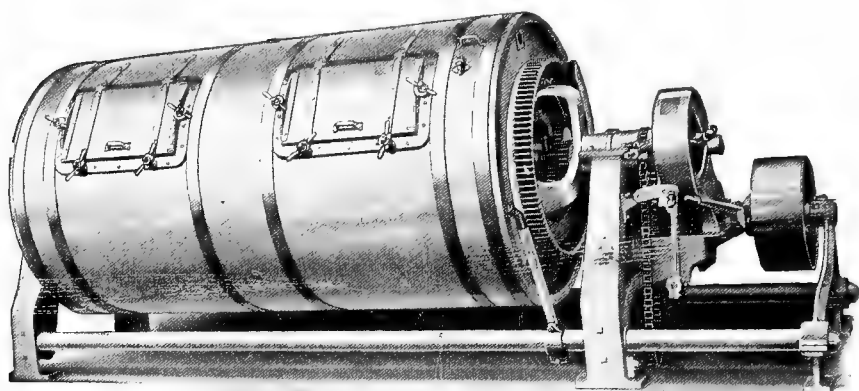

FIG. 90.—Master dual churn (Creamery Package Mfg. Co.)

temperature may vary between wide limits, but the average desirable churning temperature under normal conditions is between 50° and 60° F. It may, and does, go outside these

limits at times; for instance, many creameries find it necessary to churn at a temperature under 50° F. in the early part of the summer season, when the grass is very young and succulent and the proportion of soft fats is very high. Any conditions which tend to harden the butter-fat

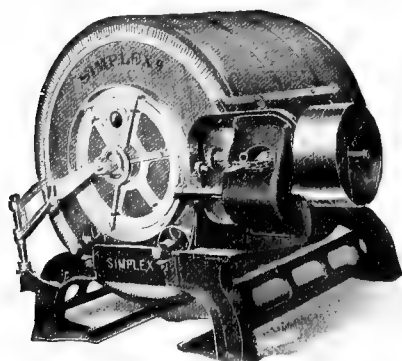

FIG. 91.—Simplex churn (D. H. Burrell & Co.)

will require a comparatively high churning temperature; and any conditions tending to soften the butter-fat will require a

lowering of the churning temperature. The lower the temperature at which the churning can be successfully accomplished, the more complete will be the churning; that is, the less fat will remain in the buttermilk.

Influence of Length of Time Held at Churning Temperature.—The length of time that cream is held at the churning temperature is a factor that must be considered. If it be found necessary to churn cream soon after cooling it, it should be cooled to a lower temperature than would otherwise be necessary. Cream should be held at least two hours at churning temperature before it is churned—better a longer time. It takes this length of time at least for the fat, which is a poor conductor of heat and firms slowly, to reach the temperature of the serum of the cream and become firm.

In the same creamery, with cream of the same richness, we have observed that cream churned immediately after cooling would churn as readily at 51° to 52° F. as cream held at 56° F. overnight and churned without change of temperature. The per cent of fat was much lower in the buttermilk from the cream held overnight than it was in that from cream churned soon after being cooled.

Richness of Cream.—The amount of fat in the cream affects the churnability of it considerably. The richer the cream the sooner will the churning be completed, that is, providing the cream is not rich enough to be so thick as to cause it to adhere to the inside of the churn and thus escape being agitated. If rich cream is churned at a high temperature the butter will come in a remarkably short time, providing all other conditions are favorable. Thin cream churns much more slowly, and can be churned at a higher temperature than thick cream, without injuring the quality of the butter. When rich cream is churned at a high temperature, and the butter comes in a short time (about ten minutes), the butter will usually be greasy in body, and will contain a great deal of buttermilk, which will be more or less difficult to remove on washing. When thick cream is being churned, the butter does not break in the form of small round granules, as it does when thin cream is churned.

When thick cream is churned at as high a temperature as is consistent with getting a good texture, the best results are obtained. In the first place, rich cream produces less butter-

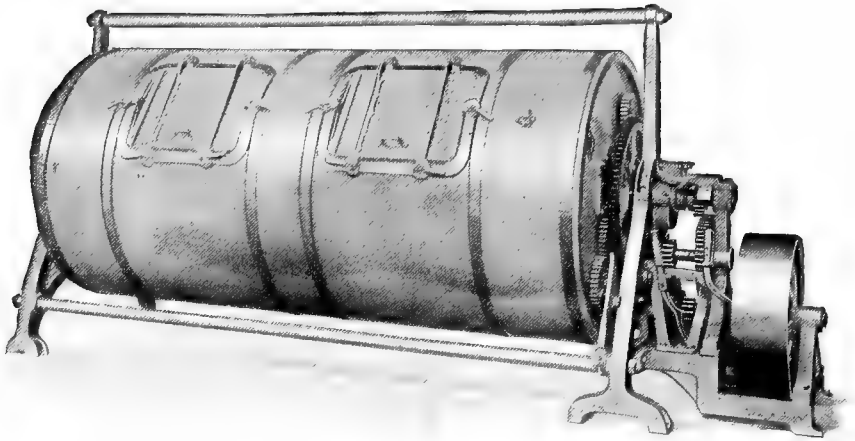

FIG. 92.—Victor heavy duty churn (Creamery Package Mfg. Co.)

milk, consequently less fat will be lost in the buttermilk. This would tend to increase the overrun. Secondly, the breaking of the butter at the end of the churning will be such as to cause the granules to appear large and flaky, rather than small and round. The more flaky granules of butter will retain more moisture than the smaller, harder granules under the same treatment. Experiments show that when different thicknesses of cream (thin cream containing on an average 22 per cent of fat, and thick cream 36 per cent of fat) are churned, there is a difference of about 3 per cent in the moisture-content of the butter. The average churning temperatures of cream and wash-water in these experiments were 56° and 53° F. respectively.

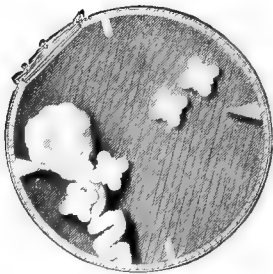

FIG. 93.—Sectional view of four roll Victor working butter.

When thick cream is churned, and the temperature is mod-

When thick cream is churned, and the temperature is mod-

erately high, it is almost impossible to churn the butter into granules. This condition causes butter from thick cream to contain more moisture than butter from thin cream.

Amount of Cream in Churn.—When the churn is about one-third full, the greatest degree of agitation is obtained, and consequently a quicker churning. If a small amount of cream is being churned, it is often difficult to gather the butter properly.

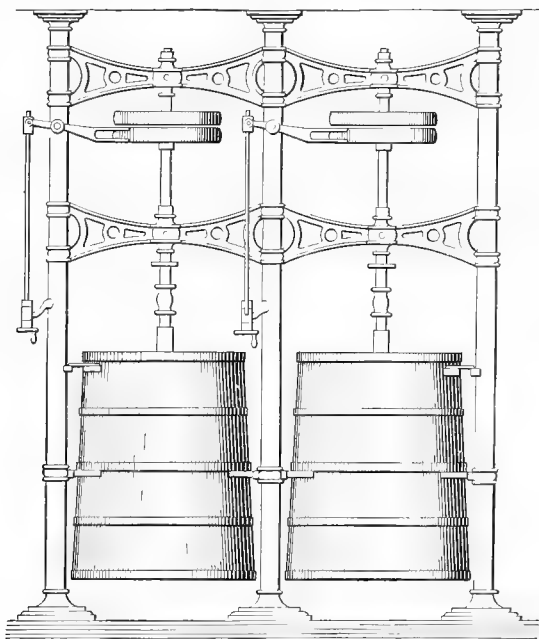

FIG. 94.—Danish churns and frame for holding them.

If the cream is thin, the granules are thrown about in such a way that they are gathered with difficulty. If the cream is thick, the small amount of cream will adhere to the inside of the churn, and in that way delay the completion of the churning.

It is a common opinion that less overrun is obtained from a small churning than from a large churning. It is safe to say that if it were possible to maintain all conditions alike, especially as to temperature and degree of churning, there would be very

little difference in the moisture-content of the butter made from churnings of different sizes. When there is only a small amount in the churn, the atmospheric temperature is likely to raise or lower the temperature of the cream. If the atmosphere is warm, then the butter from the small churning is more likely to be soft. A small amount of cream in the churn is also more likely to be overchurned than a larger amount of cream. These two factors would tend to increase the amount of water in the butter. In mixing the salt with a comparatively large amount of butter, less working is necessary. Much of the butter is mixed in the churn without going through the workers, and consequently less moisture will be expressed from the butter. With the same number of revolutions of the churn the butter from the small churning is worked correspondingly more than the butter from a larger churning. Medium firm butter, to a certain limit, loses about .2 per cent of moisture for every revolution that it is overworked in the absence of water.

Degree of Ripeness.—The riper the cream is, all other conditions being the same, the easier it will churn. Sweet cream is viscous, and consequently the fat-globules will not unite as readily. The acid developed in the cream seems to cut or reduce the viscosity of the cream, although it causes it to become thicker in its consistency. Cream in an advanced stage of ripening is brittle, so to speak; that is, if a sample of the properly soured cream is poured from a dipper it will not string but break off in lumps.

If very thin cream is overripened, the curd is coagulated. When this thickly coagulated cream is churned, the solid curd breaks up into small curdy lumps. These small lumps of curd are likely to incorporate themselves in the body of the butter and injure its quality, and also its keeping quality. If thin cream has been overripened, it should be strained well, and care should be taken not to churn it to such a degree as to unite the granules into lumps before the churn is stopped. If the churn is stopped while the butter is in a granular form, the most of these curdy specks can be separated from the butter by copious washing. Some specks are likely to remain in the

butter when the cream is in such a condition, but by following the plan outlined enough of the specks can be removed from the butter so that its commercial quality will not be injured. The degree of ripeness of cream does not have any effect upon the composition of the butter, except in increasing the curd content as mentioned.

Nature of Agitation.—The nature and degree of agitation of cream affect the churnability considerably. Many different kinds of churns are on the market at the present time. The rotary drum-churns, now used almost universally in this country, are claimed to give the greatest degree of agitation; that is, providing the churn revolves at a proper rate of speed. If the speed is so great as to cause the cream to be influenced by the centrifugal force generated, rotating it with the churn, then no agitation will take place. Consequently the churning process will be delayed, if not entirely prevented. If the speed of the churn is too slow, the degree of agitation of the cream will not be at its maximum, as the cream will tend to remain at the lowest portion of the churn without being agitated.

In the old-fashioned dash-churn the cream was not exposed to much agitation. In Europe the upright barrel-churn with rotary stirrers inside is mostly used. It is slower than American churns, but gives good satisfaction.

Extensive investigational work conducted by the American Association of Creamery Butter Manufacturers, under the direction of one of the authors, has shown that there are several factors which have a direct bearing upon the exhaustiveness of the churning of cream. With very sour cream that has been pasteurized, the loss of fat in buttermilk is much larger than is generally recognized by buttermakers. The average loss of fat in buttermilk, according to hundreds of analyses made by the American Association of Creamery Butter Manufacturers, is more than five-tenths of one per cent.

The loss of fat in buttermilk varies somewhat with the seasons of the year. During the hot weather in the summer months, especially in the flush, the loss of fat in buttermilk is greater than in the fall and winter months. One creamery

that makes a practice of testing its buttermilk daily reported to us that for the months of June and July their average loss was .85 per cent, some samples running as high as 1.25 per cent. Their tests were made by the Mojonnier method. So there is no question concerning the accuracy of the results obtained.

The high per cent of fat found in buttermilk during the period when cream is very sour is no doubt caused by the high acid coagulating a portion of the casein into small hard lumps, which are not entirely broken up by the process of neutralization or churning.

Another thing that will affect the loss at this period is, the amount of cream received is very large; buttermakers are crowded with work, churns are filled too full, and cream is not held for a long enough period at churning temperature to thoroughly chill the fat. The result is that the large globules unite quickly in the process of churning, due to the soft condition of the fat, and the smaller fat globules are carried off in the meshes of the casein into the buttermilk. It may be possible that the high acid in the cream partly removes the film from the larger fat globules, and in the process of churning they break up into smaller particles of fat. We have no positive knowledge that this is the case.

In the investigation pursued by the American Association of Creamery Butter Manufacturers it was found that where the churn is filled about one-third full and the cream is held for several hours, or overnight, at churning temperature a more exhaustive churning is obtained than where cream is placed in the churn immediately after being cooled. Where the lack of churn or vat space compels quick churning of the cream, it is better to cool the cream down four or five degrees below the normal churning temperature. The temperature that cream can be churned at will depend upon the per cent of fat in the cream. Cream that contains from thirty to thirty-five per cent fat can be churned at a very low temperature, especially cream that contains a high per cent of acid.

The speed of the churn has also a direct bearing on the temperature at which cream can be churned, and also a bearing

on the loss of fat in the buttermilk. The speed of the churn will depend, to some extent, upon the diameter of the churn and the kind of churn used. We find the following speeds give very satisfactory results:

Simplex churn, 24 revolutions per minute.

Disbrow, Victor, Dual and Perfection churns, from 32 to 35 revolutions per minute.

Where a churn is run at a low speed, the temperature of the cream will have to be higher to cause the fat globules to unite, due to the lack of sufficient agitation.

From microscopical examination made of buttermilk, where the loss was high, it was found that the fat seemed to be lodged in the meshes of the casein. When placing buttermilk in bottles in the laboratory and permitting it to stand overnight, and taking samples from the upper or watery portion, the test of fat in this liquid portion was very low, while in the lower portion, which contained the casein, the per cent of fat was exceedingly high.

The following tests of the upper and lower portions of twelve samples of buttermilk from different churnings were made after allowing the samples to stand in half pint bottles overnight. About half the liquid, or the upper portion of the buttermilk, was decanted from the bottle in each instance, and a comparison of its test was made with that of the lower portion.

Number of sample	Test of upper liquid portion	Test of lower portion
1	.48	1.07
2	.20	.50
3	.20	.50
4	.18	.56
5	.38	.60
6	.02	1.06
7	.30	.39
8	.14	.38
9	.18	.44
10	.14	.57
11	.18	.74
12	.11	.58

Cream that is separated from sweet milk at the creamery can be ripened or soured to a fairly high degree of acidity without having the lumpy condition referred to above, and a very exhaustive churning can be had from the same, whether pasteurized or unpasteurized. Where various lots of sour cream are received at the creamery, the average per cent of acidity of the entire lot when mixed together may not be very high, but some portions of this cream possibly have contained an acidity of well over 1 per cent; hence, the loss of fat in such cream would be greater than if the cream had been separated from sweet milk and where the souring was under the control of the maker. To get an exhaustive churning with sour cream, the same should have the acidity reduced to a low degree. Partial neutralization has the effect of putting the casein in a more flocculent condition; hence, the loss is not as great.

Neutralization should always be done before pasteurization, as otherwise the heat of pasteurization will precipitate some of the casein into hard lumps, which will not be broken by the agitation of the churn in the process of churning.

As far as the working of butter goes, any of the modern churns will do efficient work, especially when the maker has got himself accustomed to the churn he is operating.

Size of Fat-globules.—Cream containing large fat-globules churns more quickly than cream containing small globules and a more exhaustive churning can also be obtained from it. It is, however, impossible to obtain cream which does not contain any of the small globules. The minute globules are always difficult to remove from the serum, whether it be in the churning or in the separation. In the churning there is a certain force which always tends to hold the globules in place. This force acts in a correspondingly greater degree upon the small globules. They are held in position and move only when the cream is exposed to agitation. Cream containing larger globules allows them to escape from their position with greater ease than does cream containing the minute globules. The globules which are not

removed from the buttermilk during the churning process are largely of the small type.

Straining of Cream.—Before the cream is transferred from the ripening-vat to the churn it should be strained through a fine perforated tin strainer. This can be conveniently done during the changing of the cream from the ripening-vat to the churn. Special strainers are now manufactured which can be hooked onto the churn, and the cream can run directly from the ripening-vat through the strainer into the churn. This straining of the cream separates all the lumps which are likely to appear. It also separates any other coarse impurities which may be present. If these impurities were not separated they would probably be embodied in the butter and cause an unsightly

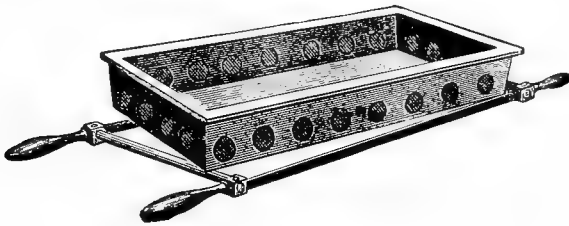

FIG. 95.—Cream and milk strainer.

appearance. They would also be likely to injure the keeping quality of the butter, but this would depend, of course, upon the character of the impurities.

Color.—In order to maintain a uniform color in the butter during the different seasons, it is essential that some artificial color be added at certain times. During the latter part of May and the early part of June the butter has a rich yellow color, which is accepted as the standard color of butter. This is often referred to as the “June color.”

There are several different butter-colors on the market, for which special merits are claimed. All the colors, so far as known, are efficient in imparting color to the butter without materially coloring the buttermilk. A good butter-color should be a substance which does not impart a bad smell or taste to the butter. It should possess strong coloring properties, so that very little

of it would have to be added in order to impart the desirable color. It should not be injurious to health. Some colors are prepared from the fruit of the annato tree, which grows in the East Indies and South America. The coloring matter on the inner part of the covering of this fruit is dissolved in a suitable oil, such as sesame or hemp.

Before any of the proper commercial butter-colors were put upon the market, extracts of carrots, marigold, saffron, and annato were used. The yolk of eggs has also been used to some extent. It is said that carrot-juice is the most healthful butter-color.

The amount of color to add depends upon the market requirements, and upon the season of the year. As was mentioned before, in June little or no color should be added. As the summer season advances the amount of color added can be gradually increased. During winter, while the cows are on dry feed, the maximum amount of color is generally used. Color requirements of the butter vary considerably at the same season of the year. American markets demand a higher color than European markets. The northern markets desire a light straw color, while the southern markets want a deeper color, almost an orange color. The Jewish trade requires uncolored butter. In some of the European countries no color is used. The English market, which is the greatest butter market in the world, demands butter that has a very light straw color. The main object in coloring butter is to maintain a uniform color during the different seasons of the year. The amount of color to add during the different seasons will usually vary between none and a trifle over 2 ounces for every 100 pounds of fat.

The color should be added to the cream before the churn has been started. If this has not been done, the butter can be colored by mixing the color with the salt. The salt should then be well distributed and worked into the butter until the body of the butter assumes a uniform color. The chief objection to this method is, that it is difficult to work in the color thoroughly without injuring the butter.

The sole object in adding color is to give the butter a more

attractive appearance. It neither adds to nor takes from the flavor or food value of butter. Hence the shade of color should be such as will make the butter most attractive in appearance. This varies somewhat with the market to which the butter is going.

When to Stop the Churning.—Different makers have various ways of ascertaining when the churning process has been completed. Some determine the proper churning stage by the size of granules, others by the height at which the butter floats in the buttermilk. Others again depend upon the appearance of the buttermilk. It is well to let all of these factors influence the operator in deciding when the churn should be stopped, as no one of them may be a sufficient indication.

The size of the granules is the most common factor that determines the time when the churn should be stopped. It has been a general rule in the past to stop the churning when the granules are a little larger than wheat-kernels. As a rule it is safer to carry the churning on a little further until the granules increase to the size of corn-kernels, irregular and flaky in shape. At this stage the buttermilk will usually appear bluish in color, and the butter is raised above the buttermilk a considerable distance. When the butter is churned to too small granules, many of them will go through the strainer into the buttermilk, and cause a considerable loss. When butter in such shape is washed in medium-cold wash-water, the granules continue to remain in a separate state. When salt is added, the moisture is extracted from them, and the water is likely to be caught in holes and crevices during the working and cause leaky butter. If the churning is carried on a little further, the granules will not escape into the buttermilk, the churning will be more complete, and the moisture will be incorporated in a better condition.

Overchurning should be avoided as much as underchurning. If butter is overchurned in the buttermilk, it will retain a large amount of the buttermilk, which will be very difficult to remove by washing. Overchurning butter, especially at a medium-high temperature, is very effective in increasing the moisture-

content of butter, and should be guarded against for that reason. Butter containing more than 16 per cent water is not permissible on the American market.

When cream is in a poor condition it should not be overchurned, as the incorporation of buttermilk produces a very rank and unclean flavor in the butter. Cream in such condition also contains many undesirable germs, which, when incor-

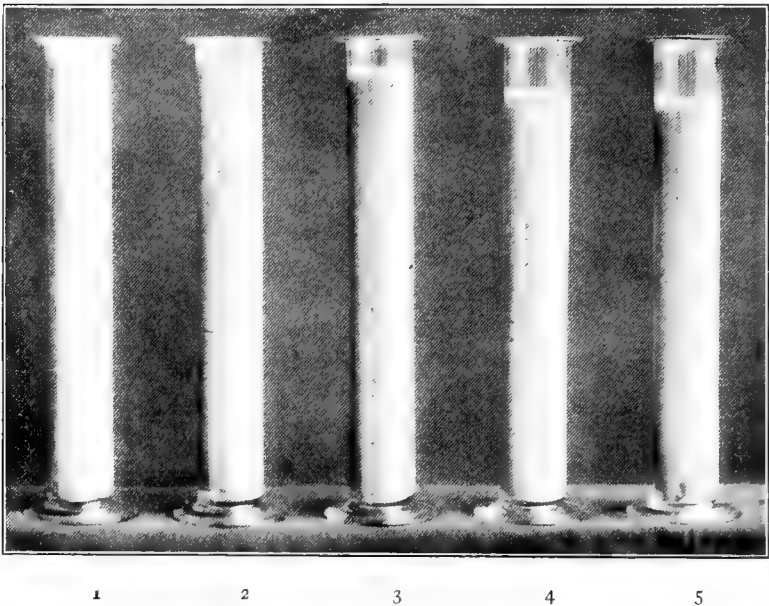

FIG. 96.—Butter from 1 pound of fat in cylinders, showing the effect of different percentages of water upon quantity. The water-content of these samples ranges between 8 per cent and 19 per cent.

porated into the butter, will cause it to deteriorate to a great extent. When the cream is in poor condition, the churn should be stopped as early as is consistent with the completeness of churning. The buttermilk should be removed and the butter washed thoroughly in clean, pure wash-water. If the wash-water is added while the butter is in this granular condition, the buttermilk can be very effectively removed. If one washing is not sufficient, wash three or four times. In such a case the tem-

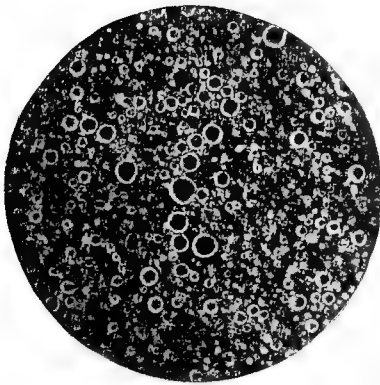

FIG. 97.—Butter sample,
15.61 per cent water.

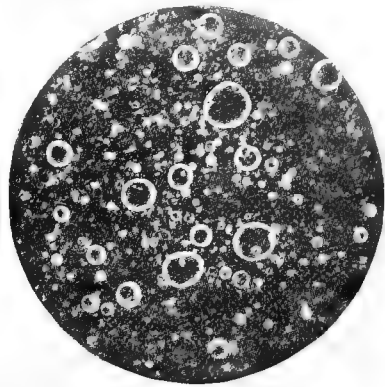

FIG. 98.—Butter sample,
15.31 per cent water.



FIG. 99.—Butter sample, 13.37 per cent water; leaky, 2 per cent brine.

Microscopical views showing condition of water in butter. Fig. 97 shows that the water has been incorporated in the form of very minute particles. Storch found from nine million to sixteen million water particles per cubic millimeter. Such butter appears dry and a little dull. Fig. 98 shows the water incorporated in medium-small particles. There were on an average three and three-fifths millions of water particles per cubic millimeter in such butter. Fig. 99 shows condition of water in leaky butter. Storch found about two and one-half million water particles per cubic millimeter in butter having such a body. (Views by Storch.)

perature should be low. If the temperature of the wash-water is high, and the butter is washed excessively, it will contain too much moisture when it is finished, and is likely to be salvy. If washed with water at a low temperature the butter will not incorporate so much water. What it does incorporate in excess, will, as a rule, be expressed during the working of the butter—a result due to its firmness.

If the attempt is made to incorporate water by working the butter in water after the salt has been added, while the butter is in a hard, granular condition, it will usually appear leaky.

If cream is in a good condition, overchurning to a small extent does not produce any bad results. The germs which are present in pure and well-ripened cream are not deleterious to the keeping quality of the butter. The amount of butter-milk incorporated in the butter is not sufficient to cause any bad effects upon its quality. If the cream is in proper condition it is difficult to incorporate any more than 3 per cent of curd into the butter. While overchurning is not to be recommended, if it is at any time desirable, it should be done in the washwater rather than in the buttermilk.

Churning Mixed, Sweet, and Sour Cream.—When two lots of cream are to be churned, one sweet and the other sour, they should be churned separately. If the two lots of cream are mixed together, the sour cream churns more quickly than the sweet cream. As a consequence the churn is likely to be stopped before the fat from the sweet cream has been completely separated from the serum.

At some of the creameries conditions are such that the operator may be tempted to mix the two lots of cream. Where sweet cream arrives at the creamery just previous to churning time, it is advisable not to mix the sweet cream with the sour. It is, as a rule, better to carry the sweet cream over to the next churning, or, if necessary, churn it separately.

Difficult Churning.—Difficult churnings in creameries are not very common. In farm butter-making they are more frequent, especially in the fall. At this time the cows are usually well advanced in the period of lactation, and early in the winter

they are often fed on food which causes hard butter fat, as described under "Effect of Food upon Fat." In the fall or early winter, a large portion of the milk is usually obtained from strippers, or cows almost dried up. Such milk contains a large portion of the small fat-globules. Difficult churning resulting from such conditions can usually be remedied by ripening to a higher degree of acidity and churning the cream at a higher temperature.

Complaints are occasionally heard of difficult churning which cannot be remedied by such treatment. Sometimes cream froths, and will not agitate in the churn. Such a frothy condition has in some cases been found to occur even though the cream may seem to be in an ideal condition for churning. It is believed by some, notably Hertz, that such a condition in the cream is brought about by a disease of the cow. Weigman has studied and isolated a ferment which caused a soapy condition of milk and cream. It is possible that such exceedingly difficult cases in churning may be due to a disease of the cow, and it may also be due to certain ferments that produce a soapy condition of the cream.

If thick cream at a very low temperature is put into the churn, it sometimes causes difficult churning. When such cream is first agitated in the churn it incorporates considerable air. This air, together with the various gases developed at a low temperature, does not readily escape. The viscosity of it is so great that it will not release the air present. As a consequence it assumes a stiff consistency, much the same as the beaten white of an egg. If cream froths in the churn as mentioned, a little warm water thrown on the outside of the churn will often start the agitation of the cream within. If a combined churn is used the rollers may be put in gear, and the churn revolved in slow gear. This will often start the cream to agitate. If these two remedies are not sufficient, a little water, lukewarm if necessary, may be added directly to the cream. By letting the churn stand a short time, the cream will usually condense into a liquid form again, and many times the churning process can then be completed. This latter method, however, usually

requires more time than can be profitably spared. If the churning difficulty is of a serious nature the remedies are:

(1) If produced by a certain cow, or herd, find out whether it is produced by a fermentative process, or by other abnormal conditions of the cow.

(2) Change the food of the cow. A succulent food will usually cause the cow to secrete more milk, and of a different nature.

(3) If produced by a ferment, endeavor to control the fermentation as previously described.

(4) Ripen the cream to a higher degree of acidity.

(5) Skim thicker cream and churn at a higher temperature.

The last three methods will cure most cases of difficult churnings.

Keeping Churn Sweet.—It has been mentioned before that butter absorbs foreign odors very readily. If the churn is not kept in a pure, sweet condition, the butter will be exposed to the undesirable odors and its commercial quality will be impaired. The best butter cannot be produced in a foul-smelling churn. As churns often are not used every day, they very readily assume this impure condition, and it is essential that special care be taken in keeping them clean.

The best method of keeping churns in good condition is to rinse the churn in two waters at the end of each churning. The first rinsing should be made with lukewarm water, the second with scalding hot water. Some prefer to turn the churn over with mouth down. Others prefer to allow the cover-hole to turn up. When the churn is turned with the cover-hole down, the remaining steam on the inside of the churn will not escape. It will condense inside of the churn, and cause the churn to remain in a damp condition overnight or even longer. If the churn is turned with the cover-hole up the dust and other impurities, if present, are likely to settle into the churn. A good way is to turn the churn over so that the cover-hole points to one side. The churn should be thoroughly drained first, otherwise some water will remain in the bottom. When the churn is left with the cover-hole at one side, the steam can escape,

and the heat absorbed from the wash-water will dry the churn thoroughly. Many makers rinse the churn only once and use scalding hot water. This method is likely to scald the remaining curd on to the wood; secondly, one rinsing is not enough to insure a clean churn. The first rinsing with lukewarm water removes the major portion of the buttermilk and brine, and to a certain extent warms the wood of the churn, so that when the second rinsing with scalding hot water is completed, the churn has been thoroughly scalded. In addition, the churn is clean, and no food is left on which germs can thrive. The churn is also left warm, and in that condition will dry quickly.

Some makers prefer to keep the churn in a good condition by sprinkling salt on the inside after washing. This is not to be recommended, as all churns contain more or less iron-ware on the inside. Salt, while a fair germicide, causes the formation of rust on all iron with which it comes in contact. After a time this rust will scale off to a certain extent and become incorporated with the butter.

If the churn is treated daily in the manner described above and then at the end of the week treated with slaked lime, it can be kept in a good sweet condition. The lime should be freshly slaked and in a liquid condition when put in the churn. A pailful or two of this fluid will be sufficient for each churn. By rotating the churn a few times the lime will be spread all over the inside of it. Let the churn remain in this condition until ready for use again. When ready for use, put in some warm water, and the lime will readily come off. But if it has been allowed to remain in the churn too long, it will form a lime carbonate, and will be more difficult to remove.

Lime is one of the best disinfectants and deodorizers that can be used in a creamery. Some of the best butter-makers use it every day on all the wooden utensils, such as butter-workers, churns, etc. Lime can be used more advantageously in American creameries than it is to-day. Many creameries would be in a much sweeter and purer condition if they were given a good coat of whitewash on the inside once a month. Refrigerators, wooden utensils, and rooms of any kind can be kept in a good,

sweet and pure condition by whitewashing or sprinkling a little lime on them.

In the preparation of a new churn for use it is a good plan to treat it with milk of lime in the manner already described. It will fill the pores of the wood and harden it, and remove all danger of imparting a woody flavor to the butter of the first churnings made in the churn.

To Prevent Butter from " Sticking " to the Churn.—At times churns get into a condition in which butter sticks or adheres to them more or less. Sometimes it requires treatment with a weak acid solution to overcome this difficulty, and sometimes treatment with an alkali solution is needed. If treatment with acid is what is needed, a weak solution of either sulphuric or muriatic acid may be used—say a pint to 100 gallons of water. The acid must be added carefully to the water in the churn and none of it must be poured directly upon the wood. The churn is revolved with this solution in it, for about five minutes at a time, at intervals extending over a period of several hours. It is then rinsed with warm water and then with water containing a little of some good washing powder, such as Wyandotte. If treatment with an alkali solution is needed, which is the case if fat has soaked into the wood, a suitable washing powder may be used to remove the difficulty. The following is an extract from a letter received from one of our leading creameries which had written for and received suggestions from one of the authors for overcoming this difficulty: " We received your letter in regard to the trouble we had with the butter sticking to our churn. We are pleased to advise that we have apparently eliminated all of this condition. When we received your letter suggesting remedies which might stop this condition, we at first used the muriatic acid but without any results whatever. Then our butter-maker took about three pails of Wyandotte, put in a small amount of water and heated with steam until he made a sort of a paste out of it. He then put it in the churn and gave it several revolutions and let it stand overnight, then washed it out thoroughly with hot water. The first time it seemed to help it very considerably, so we gave it another dose a day or two

later and it has relieved the whole condition. He is of the opinion that if this is used when the butter shows any tendency to stick to the churn, it will keep the churn in good condition right along."

WASHING OF BUTTER

Purpose of Washing. The chief object of washing butter is to remove as much buttermilk as possible. The more impure the cream is, the greater is the importance of getting the butter thoroughly washed. In the winter, when it is cold, and the cream is in good condition, some makers do not wash the butter at all. But this is not a safe method. The removal of the buttermilk constituents should be as complete as conditions will permit.

Temperature of Wash-water.—The temperature of wash-water should be as nearly like that of the cream when churned as is consistent with the other conditions. It is quite a regular practice in many creameries, particularly in summer, to temper the wash-water to about 2° below the churning temperature of the cream. Extreme and rapid changes in temperature should always be avoided. Occasionally it is necessary to use water that is colder than the cream; at other times it is necessary to use wash-water at a higher temperature than that of the cream. If the butter churns soft, do not use ice-cold wash-water to chill the butter, as it has a tendency to give butter a tallowy appearance. Neither should hard butter be quickly softened by using wash-water at a very high temperature, as it is likely to cause the butter to assume a greasy and slushy texture. If it is necessary to change the degree of hardness of the butter, change it gradually by using water at a moderate temperature and allowing the butter to be in contact with it a longer time without agitating it much.

The regulation of the condition or degree of firmness of butter, for the proper working of it, should never have to be accomplished to any great extent by means of the wash-water. This is not the real purpose of washing butter. If the churning tem-

perature of the cream be right, the butter will be in proper condition for washing and working. If the churning temperature be not right it is difficult through any device that may be adopted subsequently—such as tempering the wash-water—to bring the butter into the best condition for salting and working. Regulation by means of a change in temperature of the wash-water will prove a partial, but not a complete remedy—particularly if the butter be very soft when it comes.

Unless the butter is of very poor quality, excessive washing should be avoided. Cold water is said to absorb a considerable portion of the flavoring substances. If the quality of the butter is poor, many of the undesirable flavors and odors are removed by excessive washing; while if the butter has a fine, rich flavor, it should be retained, and not extracted by washing the butter more than is needed. No definite temperature can be given, as the temperature of wash-water must vary according to the hardness of the butter when churned.

If the temperature of the wash-water is too high, and the churning in the wash-water is continued a very long time, much water will be incorporated in the butter. If the butter is quite firm in the first place, and the temperature of the wash-water is not above 60° F., there is not much danger of getting too much water in the butter. Rapid changes in the degree of hardness of the butter in the presence of water are conducive to a high moisture-content. Very soft butter chilled in very cold water, and hard butter softened in very warm wash-water are two conditions which should be avoided.

As to the quantity of wash water that should be used: with cream of average richness, it will be about the same as that of the buttermilk; with very rich cream a little greater. In washing the butter the churn is usually run from 10 to 15 revolutions on high speed. Some, instead of following this practice of churning the butter in the wash water, run the churn about 2 to 5 revolutions at slow speed with the worker in gear; modifications and combinations of these two methods are made. For instance, where butter is first washed or sprayed and a second wash-water is used, some adopt the practice, during the second washing, of

revolving the churn a few times on high speed while others put the rolls in motion using the slow gear.

Butter from cream of good quality, churned at the right temperature, needs less washing than butter from cream of poor quality or butter churned at too high a temperature. Two washings should suffice when the cream is of good quality, and with such cream some wash the butter only once if the wash-water runs off clear. In order to possess good keeping qualities, butter must have the buttermilk well washed out of it. Butter from cream of poor flavor requires more washing than butter from cream that is clean in flavor.

Kind of Wash-water to Use.—In the washing of butter, it is very essential that water used should be the best obtainable. The creamery water-supply is evidently much better now than it was years ago. Pond-wells and shallow wells are gradually passing out of existence, but there are yet many shallow wells from which water is drawn for creamery purposes. Water from wells may appear to be pure, and yet contain germs which are deleterious to dairy products, and especially to the keeping quality of butter. That water of average purity contains such germs has been demonstrated in this country, as well as in foreign countries. Shallow well water contains on an average about 15,000 germs per cubic centimeter, but Miquel has found that a rapid power of multiplication characterizes the bacteria in pure spring-water, while in impure water the multiplication is slower. Water containing only this number of germs is, as a rule considered very pure. Most creameries, however, pump their water into a tank overhead in the creamery, where it is contaminated with bacteria and impurities of different kinds.

Shallow wells are usually surrounded with conditions which do not guarantee a creamery pure water during the different seasons of the year. In the spring, when rains are frequent and heavy, unwholesome surface-water is likely to seep in through the sides. Such wells may also serve as traps for small animals. The presence of an animal in the well is sure to cause undesirable odors and a multitude of undesirable and putrefactive organisms.

Water from deeply drilled wells, even if it is pure in so far

as its germ-content is concerned, is in many cases turbid and sandy, and needs to go through a process of purification as much as does the shallow well water.

METHODS OF PURIFYING WASH-WATER

There are two practical and effective methods of purifying wash-water, viz., (1) Filtration, and (2) Pasteurization. Which of these two methods is the most practicable and the most effective in the creamery depends upon the conditions and upon the quality of the water. In the case of water from deep wells, which contains little or no organic matter, but at the same time is infested with undesirable germs, pasteurization is perhaps more expedient. Filtration, if the same degree of thoroughness is to be reached as in pasteurization, is a comparatively slow process. Pasteurization of wash-water is a trifle more expensive than filtration. Wash-water can be pasteurized at the same time that the churning is being done, thus economizing in time and fuel. Pasteurization is quite effective in rendering the water germ-free, but it is not so effective in removing any organic matter or other tangible impurities which may be present. If the creamery does not already have a pasteurizer, filtration can be employed very profitably, and under average conditions it will perhaps give the best results.

Filtration.—Filtration is inexpensive, and is a very efficient method of purifying wash-water. It seems strange that bacteria can be removed from water by passing through layers of sand, gravel, coke, and charcoal, but such is the case. Filtration is applicable to all kinds of water; even if the water appears pure, it is well to filter it. Fewer germs and fewer varieties of micro-organisms are apparently found in deep well water than is the case in water from surface-wells; hence the ferments which are present will have a free field for developing in the absence of competing forms. If a sample of water which is rich in micro-organisms is violently shaken with a certain amount of charcoal, coke, chalk or similar substances, and then left for a time to settle, the pure layer of water at the top will be

almost entirely free from germs, and in some cases entirely sterile. It used to be thought by older German investigators that these different filtering substances had almost miraculous power of removing organisms from water.

The factors which are to be considered in successful filtration are:

- (1) Storage capacity for unfiltered water.
- (2) Construction of filter-beds.
- (3) Rate of filtration.
- (4) Renewal of filter-beds.

(1) Concerning the storage capacity, nearly all creameries have storage-tanks overhead in the creamery; so far as that is concerned, however, filtration can be successfully carried on continuously as well as intermittently.

(2) The construction of the filter-bed used in the experiment carried on at the Iowa Experiment Station, Ames, Iowa, is as shown in Fig. 101. The approximate proportionate depth of each layer in the bed is as follows, beginning at the bottom:

Two inches small flint stones; 22 inches fine sand; 12 inches fine coke; 9 inches charcoal; 2 inches fine stone or coarse gravel. The layer of fine sand should not be less than 15 inches. It has been asserted that a few pieces of old iron mixed in the filter-bed are beneficial. Alum, lime, and copperas have been recommended for clarifying and deodorizing very impure water. As these substances are soluble they should not be used in filter-beds, which are intended for the filtration of water for potable purposes. The filtering-can was made from 22 galvanized iron. The height of can is 48 inches; diameter, 18 inches. The bottom of the can is slanting towards the faucet, or opening. Thus no water is permitted to stand on the bottom and afford opportunities for germs to accumulate. On the inside are three plates. One lies horizontally, near the bottom, and upon it the filtering-material rests. Another lies on the top of the fine sand. Both of these plates were perforated with many small holes. Near the top is placed a concave plate with a hole near the center. This plate directs all the water to the center of the filter-bed, and thus the water gets the full benefit of the filtering process. The

total cost of this filtering-can when complete was \$11.11. Since the time when this can was constructed prices have advanced considerably.

(3) The rate of filtration is necessarily governed by the depth of the filter-bed, the character of the material used, and its

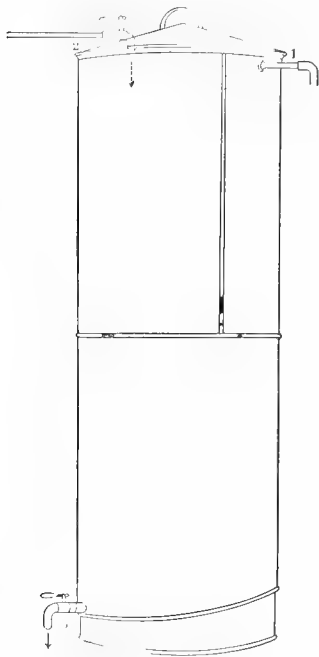

FIG. 100.

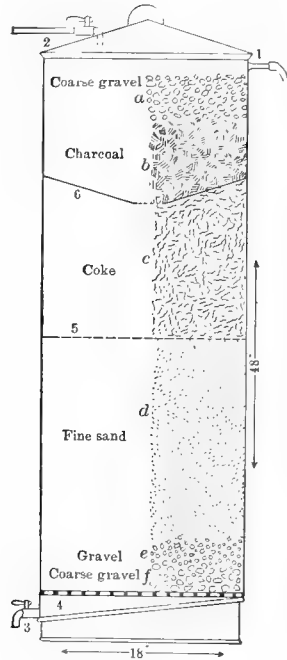

FIG. 101.

FIG. 100.—Filter-can; 1, overflow; 2, inlet of tap-water; 3, outlet of filtered water.
 FIG. 101.—Cross-section of filter-bed and can: 1, overflow; 2, inlet; 3, outlet of filtered water; 4, perforated galvanized-iron plate; 5, perforated galvanized-iron plate; 6, concave galvanized-iron plate with hole in center.

fineness. The water passes through the charcoal, coke, and gravel quite rapidly, yet the substances are very strong barriers to the passage of micro-organisms. The sand layer does not admit of such rapid filtration. Fine sand, however, is one of the best filtering substances that can be had. The rate of filtration can be regulated by increasing or decreasing the depth of the

fine-sand layer. In a general way, the slower the rate of filtration is, the more thorough it is; and, *vice versa*, the more rapid the rate of filtration, the more incomplete is the removal of the bacteria. If the filter-bed is constructed as described above, the rate of filtration will be about 18 gallons per hour, and about 96 per cent of all the germs present will be removed, together with the impurities present in suspension.

(4) The filter used at the Iowa Experiment Station was in constant use for about three months, without having been changed. At the end of this time it did as efficient work as at any previous time. The length of time a filter-bed can be used without being changed depends upon the purity of the water to be filtered, and also upon which kind of filtration is used, the continuous or the intermittent. The more impure the water which has to be filtered, the oftener the filter-bed should be changed. Whenever the rate of filtration is decreased to such an extent as to make the process impracticable, the filter-bed should be taken out and cleaned. If the water to be filtered is of average purity, a change of the filtering-material once every four months is ordinarily sufficient, no matter whether continuous or intermittent filtration is used. A filter-bed may do efficient work even a longer time than this. The same filtering-material can be used again providing it is thoroughly washed previous to replacing it in the filtering-can.

Kinds of Filtration.—The two kinds of filtration in use are (1) Continuous, and (2) Intermittent.

By the continuous method of filtration the inflow of water into the can is constant during night and day. The stream of water admitted into the filter-can is sufficient to cause the surface of the filter-bed to be covered with water all the time. This method excludes all oxygen from the filter-bed, except that which is in solution in the water.

During the process of filtration a slimy coat is deposited on the fine sand. This seems to be the real agent absolutely necessary in order to eliminate bacteria by a process of filtration. A filter-bed without this slimy deposit on it simply takes out the coarse organic and inorganic matter held in suspension, without

removing the bacteria. If some bacteria are removed with the matter held in suspension, others are carried along from the filter-bed. Owing to this, a new filter-bed must be kept in operation a few days before the filtered water can be considered pure and ready for use. The following table illustrates how the germ-content of water is decreased as the process of filtration is carried on during the first few days:

	Filtered Water, Germs per c.c.	Unfiltered Tap-water, Germs per c.c.
No. 1. Taken when filter-bed was first used.	20,000	107
No. 2. Taken when filter-bed had worked 1 day.	860	118
No. 3. Taken when filter-bed had worked 3 days.	370	96
No. 4. Taken when filter-bed had worked 5 days.	48	54
No. 5. Taken when filter-bed had worked 7 days.	3	73
No. 6. Taken when filter-bed had worked 9 days.	5	89

It will be seen from the table that during the first three days the filter-bed was in use the filtered water contained more germs than the unfiltered. Good results were not obtained until the seventh day. In order to be on the safe side it is best to expose the filter-bed to continuous filtration for about nine days before the water is used.

The slimy coat referred to above is formed by certain germs. These germs then constitute the real agent of filtration. In order that these micro-organisms may do efficient work oxygen is essential. Well-water of average purity contains enough oxygen in solution without employing an intermittent process of filtration, and consequently for creamery purposes the continuous method of filtration is to be recommended.

Intermittent.—The intermittent process of filtration is used where comparatively impure water is being purified, such as in purifying water for large cities. If the continuous process of filtration were employed in such instances, the filtered water would not be free from germs, due to the fact that impure river-

water does not carry enough oxygen in solution to supply the germs which form the real filtering agency.

If the intermittent process is used, the first water filtered after the intervening period should not be used. During the intermission, or during the time that the water is shut off, germs develop and come through the filter-bed with the water that is filtered.

Advantages of Purifying Wash-water for Butter.—The chief advantage of purifying wash-water for butter is that the keeping quality of the butter is improved, and if the proper skill and care have been applied in the other steps of manufacture, a pure sanitary product is obtained. The sanitary efficiency reached by purifying the wash-water constitutes no small consideration. Germs producing contagious diseases are thus prevented from spreading.

CHAPTER XVIII

SALTING AND WORKING OF BUTTER

Objects of Salting.—(1) The chief object in salting butter is to impart a desirable salty flavor. (2) Within limits, salt improves the keeping quality of butter. (3) Salt facilitates the removal of buttermilk.

Amount of Salt to Use to Produce Proper Flavor.—The proper amount of salt to use in order to impart a desirable flavor depends chiefly upon the market. Some consumers prefer a medium high salt-content in butter; others, again, like butter which contains very little salt. The English market demands rather light-salted butter. In fact, this is the case with practically all European markets. American markets, as a rule, demand a comparatively large amount of salt, as much as will properly dissolve in the butter. Parisian markets and some markets in southern Germany require no salt at all. The salt-content of butter may vary between nothing and 4 per cent. Butter containing as much as 4 per cent salt is, as a rule, too highly salted, and part of the salt is usually present in an undissolved condition. Those who like good butter prefer the salt thoroughly dissolved and well distributed.

The amount of salt to be added should be based upon the least variable factor. Some creamerymen measure the amount of salt according to the amount of cream in the churn. While the box-churn and Mason butter-worker were being used, many makers preferred to weigh the butter as it was transferred from the churn to the worker. The method mostly in use now and to be recommended is to base the amount of salt upon the number of pounds of fat. The amount of salt to use per pound of fat varies, therefore, according to the conditions mentioned below, and also according to local conditions. Usually from half an ounce to one and a half ounces of salt per pound of butter-fat

is most suitable. In whole-milk creameries the salt is often estimated per hundredweight or per thousand pounds of milk.

To get the butter salted uniformly from day to day is very important. A variation of 1 per cent to 2 per cent in the salt-content can very easily be detected by the consumer, while that much variation in any one of the other chief constituents could not be readily noticed.

The conditions upon which the proper amount of salt depend are: First, the amount and condition of moisture in the butter at the time the salt is added. If there is a great deal of loose moisture in the butter, more salt is necessary. This is due to the fact that the salt will go into solution in the water and be expressed during working. Secondly, it depends upon the amount of working the butter receives, and at what time the bulk of working is done, after the salt has been added. If the butter is medium firm, moisture in the form of brine is being expressed during the working. Consequently, the more butter is worked, up to a certain limit, the more brine is being expressed, and the more salt should be added to the butter. Thirdly, it depends upon the firmness of the butter, the size of the granules, and the method of applying the salt. If the granules be inclined to be soft and slushy more salt must be added than would otherwise be necessary, as more will be carried off during the process of working.

It is undoubtedly due to these facts that the salt-content and the condition of salt in butter vary so much at the different creameries; they even vary considerably from one churning to another at the same creamery. If conditions are uniform in the creamery from day to day, the amount of salt to add to butter, and the amount of salt retained in the butter when finished, will be comparatively uniform.

It was thought at one time that heavy salting covered defective flavors in butter. Such is not the case; it really accentuates them. Some of the large creameries make their second-grade cream into sweet or unsalted butter.

Effect of Salt upon Keeping Qualities.—Within certain limits salt acts as an antiseptic and improves the keeping qual-

ities of butter; but there does not appear to be any advantage to be gained from heavy salting. We submit the following short tables in support of this view, the first made up from investigations by McKay and Larsen at the Iowa Station and the second from investigations by Gray of the U. S. Department of Agriculture (Butter scored by McKay):

Number	Ounces of Salt to 1 Pound Butter	SCORES				
		When Made	At End of One Month	At End of Two Months	At End of Three Months	
Exp. 13	25	0.	92.0	85.0	75.0	65.0
	26	0.5	93.5	87.5	85.0	78.0
	27	1.0	92.5	88.0	87.0	80.0
	28	1.5	92.0	90.5	84.0	80.0
Exp. 14	29	0.	93.0	90.0	80.5	74.0
	30	1.0	94.0	89.0	86.0	87.0

Number	Per Cent of Salt	Before Storing	SCORES					
			Stored at - 10° F.		Stored at + 10° F.		Stored at + 32° F.	
			Five Months	Eight Months	Five Months	Eight Months	Five Months	Eight Months
Some	individu	al lots:						
1	1.02	88	93	90½	92¼	90	90	86
	3.20	89	90	88	89¼	86	85	84
2	1.10	91	93	91½	92	91¼	89	88
	2.87	91	90½	87	90	87	88	87
3	2.00	91½	92¼	89	89	89	91	88
	3.16	89½	91	89	90	88½	89	84
4	1.52	91½	91	88½	90½	88	88	82
	3.28	89	89	85	87½	85	86	80
Average of all Lots in the Experiment :								
Light Salt	1.64	91.7	92.6	90.9	91.70	90.6	90.3	87.8
Heavy Salt	3.44	91.2	90.5	89.9	90.15	89.0	89.0	85.0

Each "experiment" in the first table includes samples of butter from the same churning, salted at the different rates indicated.

Each pair or lot of churnings reported in the second table were from the same vat of cream.

The first table shows that salted butter keeps better than unsalted butter. The second table shows that light salting is just as effective for improving the keeping quality of butter as heavy salting. In fact, in nearly all cases lightly salted butter came out of storage, at the end of eight months, with a higher score than butter that was heavily salted. This would be due in part to the salt bringing out defects in flavor.

Salt Facilitates the Removal of Buttermilk.—That salt facilitates the removal of buttermilk can easily be demonstrated by observing the escape of buttermilk from the butter immediately after the salt has been added and mixed with the butter. The first effect of salt when added to the butter is to precipitate the curd in the buttermilk. This precipitation is greater when a large amount of salt is added than when only a small amount is added. The precipitation of the casein in the buttermilk sets free the remainder of the buttermilk constituents; that is, when the casein is precipitated, the whey part assumes a more fluid condition and escapes, and the butter retains a portion of the curd. Owing to this action of the salt, it is essential that the butter should be as completely washed as possible, as otherwise it will retain an excessive amount of curd. The butter acts in a manner somewhat similar to a filter in removing a part of the curd from the other buttermilk constituents.

Salt in Relation to Water in Butter.—Experiment has demonstrated that pure fat is not a salt-dissolving substance. Owing to this fact the only salt-dissolving substance in butter is water. As water will hold only a certain amount of salt in solution, it becomes evident that the amount of salt which can be properly incorporated in butter depends upon the amount of moisture present.

The amount of salt which water will hold in solution at

different temperatures varies somewhat according to different investigators. According to Gerlach¹ water will dissolve 35.94 per cent salt at 58° F. This is approximately the temperature at which salt is worked into butter. Theoretically, butter containing 15 per cent of water should be able to properly dissolve 5.4 per cent of salt. Butter containing 13 per cent of water should be able to properly dissolve 4.68 per cent of salt, and butter containing 10 per cent of water should be able to dissolve properly 3.6 per cent of salt, etc. According to experiments

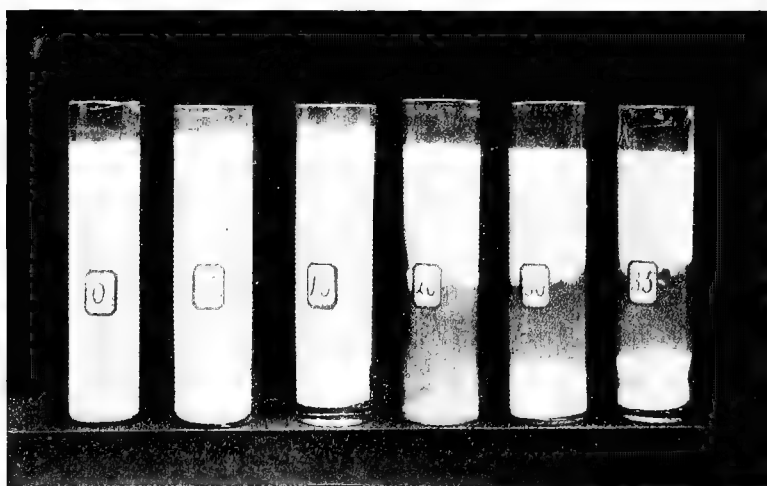

FIG. 102.—Action of salt solutions of different strength on the proteids of buttermilk. (Bul. 263, Gen., N. Y.)

conducted at the Iowa Experiment Station the maximum per cent of pure salt (NaCl) that could be properly dissolved *in water* of butter containing 16.92 per cent of moisture, when worked 18 revolutions at intervals during two hours, was 16.57 per cent. When butter was worked the same number of revolutions at intervals, and was allowed to dissolve only one hour, the amount of pure salt (NaCl) that was dissolved in the water of the butter containing 11.58 per cent moisture was 14.09 per cent. This undoubtedly will vary with different brands of salt.

¹ Kemiker-Kalender, p. 219.

It will thus be seen that the property of water to take up salt is seemingly lessened when the water is present in a state of minute division, as it is in butter. In the first instance quoted the butter completely dissolved about 2.7 per cent of pure salt; and in the second instance it dissolved only about 2 per cent during one hour.

From the foregoing it is evident that where butter contains a high per cent of salt, the salt is not thoroughly dissolved.

Kind and Condition of Salt.—Salt for butter should be fine

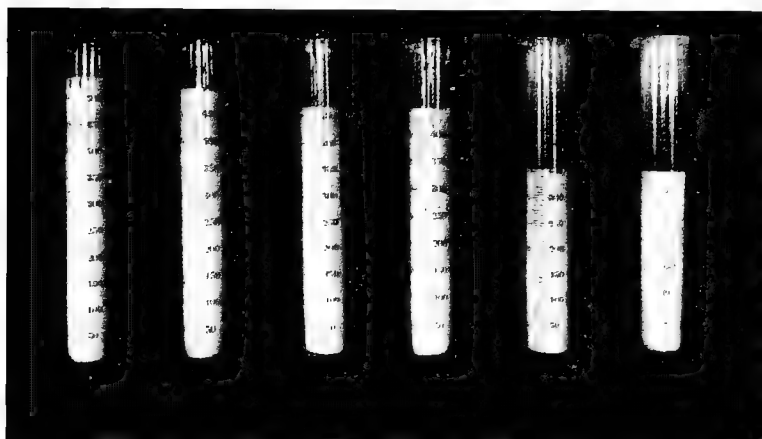

FIG. 103.—Volumes of the same weight of salt of various brands.
(Bul. 74, Wis.)

and readily soluble, so that it will be completely dissolved and incorporated when the working of the butter is completed. But fineness alone does not determine solubility; some salts that do not seem very fine are quite readily soluble, because the crystals are somewhat flat and flaky and dissolve quite quickly. Again, good dairy salt is clean and white in appearance. When it is dissolved in a cylinder of water there should be no settlements and nothing left floating on the surface of the water.

Some salt is chemically impure, one of the impurities being magnesium chloride, which, when present to any extent, imparts a bitter flavor to butter. Good butter salt is practically free

of this impurity. According to analysis of the best dairy salt used in Denmark, the composition is as follows:¹

	Per Cent
Pure salt (sodium chloride (NaCl))	97.49
Magnesium chloride (MgCl ₂)18
Gypsum (calcium sulphate (CaSO ₄))05
Sodium sulphate21
Water	2.07
	<hr style="width: 10%; margin-left: auto; margin-right: 0;"/> 100.00

The purest American dairy salt has the following composition:²

	Per Cent
Pure salt	99.18
Magnesium chloride05
Gypsum54
Calcium chloride (CaCl ₂)19
Insoluble matter03
Moisture01
	<hr style="width: 10%; margin-left: auto; margin-right: 0;"/> 100.00

Good, moisture-free salt will contain 99 per cent or over of sodium chloride (NaCl). Any substance other than this is an impurity to the extent to which it occurs.

Salt readily absorbs odors and moisture. Hence it should be kept in a clean dry place.

Gritty Butter.—"Gritty butter" is a familiar phrase used by expert butter-scorers to indicate that part of the salt is present in an undissolved condition. To most consumers this condition of the salt in butter is objectionable. When properly incorporated, salt should be present in the form of a solution in the butter. The gritty condition of the salt in butter may be due to (1) poor condition of the salt before it is added to the butter; (2) adding so much salt that it cannot be dissolved by the water in the butter. The maximum amount of salt that

¹ Boggild, Maolkeribruget, Denmark.

² Bul. No. 74, Wis., by F. W. Woll.

butter will dissolve depends upon the amount of moisture present. The maximum amount of moisture permissible in butter, according to the Treasury ruling, is 16 per cent. The condition of the water in butter prevents the water from being saturated with salt during the comparatively short time allowed for salt to dissolve during the manufacture of butter. (3) Insufficient working. If the butter is not worked enough to distribute the salt evenly, some portion of the butter will contain more than the other portions. The portion that contains the excess

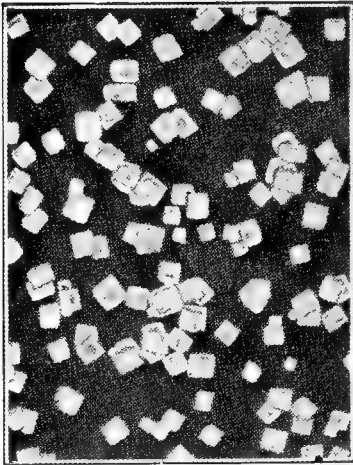

FIG 104.—Worcester salt.



FIG 105.—Diamond crystal salt

Types of crystals of buttersalts

of salt does not have enough moisture to dissolve the salt; while if the salt had been evenly distributed in the butter, all the salt would have been properly dissolved. When gritty butter is caused by insufficient working, it usually mottles.

Mottled Butter.—Mottled butter is butter which is uneven in color. This may be due to different causes. The most common cause, however, is failure to get the salt properly dissolved and evenly distributed by the time the working of the butter is completed.

The causes and remedies for mottles are pretty thoroughly understood by almost all up-to-date butter-makers. Twenty or twenty-five years ago mottles constituted one of the leading defects found in the creamery butter supplied to our markets. Charles Y. Knight, then editor of *Chicago Dairy Produce*, offered a series of prizes for the best methods of preventing mottled butter, and many creamerymen entered the competition. The result was that a lot of valuable information was obtained, which resulted to a very large extent in preventing mottled butter. Many theories have been advanced as to both the cause and the remedy for mottles.

Long before creameries were established some farmers' wives had mastered the art of butter-making to the extent that they produced butter of a uniform quality free from mottles. This was accomplished by their methods of working. Possibly they had no knowledge of what actually caused mottles, but they knew that if they worked the butter sufficiently to thoroughly incorporate the salt mottles would not appear in the finished butter.

Drs. Van Slyke and Hart say that if the proteids are thoroughly washed from the butter, mottles cannot be produced, no matter how unevenly the salt is distributed. Complete removal of the buttermilk by washing is one of the essentials in preventing mottles in butter.

Storch made an extensive study of the causes of mottles in butter. He claims that the water in butter is present in two forms or conditions. There is the water which is contained in the form of an extremely fine emulsion in the nitrogenous material composing the film surrounding the fat globules; and there is the water which is enclosed by the granules as they form or is picked up later from the buttermilk or the wash-water, and which is present in the finished butter in the form of larger droplets, or a much coarser emulsion. The whitish, opaque dapples, Storch claims, are due to the fine emulsion of water in the nitrogenous material referred to, and the yellow, clearer markings to the larger droplets of water picked up from the buttermilk and wash-water.

Sammis and Lee repeated a portion of Storch's investigation. They found that butter-fat, freed from casein by melting and filtration, then emulsified with water and churned, produced typical mottles when the salt was not evenly distributed throughout the mass. They thus produced mottles entirely independent of the casein. Microscopic examination of such butter showed similar results as in the case of Storch's experiment. In the portions which were lighter in color, the water was present in the form of innumerable small droplets, while in the portions that were darker, the droplets of water were much larger. No counts nor measurements of the droplets were given. These investigators emphasize the importance of thorough working of the butter to prevent the mottled appearance.

The mottles caused by improper incorporation of salt assume two different forms, viz., mottles proper, and wavy butter. As has been mentioned before, the mottles result from undissolved salt. Whenever there is undissolved granular salt present, the moisture is attracted and the color deepened at that particular place. In case the water has already been saturated with salt, there is no danger of mottles, no matter how much gritty salt is present.

Mottles do not affect the quality of butter, but the consuming public desire uniformity in color. For this reason butter is artificially colored during the winter months when cows are on dry feed which is not conducive to the production of a yellow color in the butter. Many people like the appearance of marble cake; the same people would seriously object to marbled butter.

The salt which is placed on butter or mixed with it has an affinity for water. Therefore, the droplets of water are attracted to the granules of salt. The result is that a certain portion of the butter assumes a dark appearance, possibly somewhat similar to the clouds appearing before a rainstorm; or, in other words, mottles may be said to be caused by the uneven distribution of the water droplets.

It will be observed that the white streaks in butter contain little or no salt. Professor O. F. Hunziker has done very extensive work on this subject. The white opaque places in

mottled butter are caused by the localization of innumerable very small water droplets.

There are a number of things that have a tendency to cause mottles. In the early spring, when the cows are changed from dry feed to grass, mottles are more prevalent than at any other

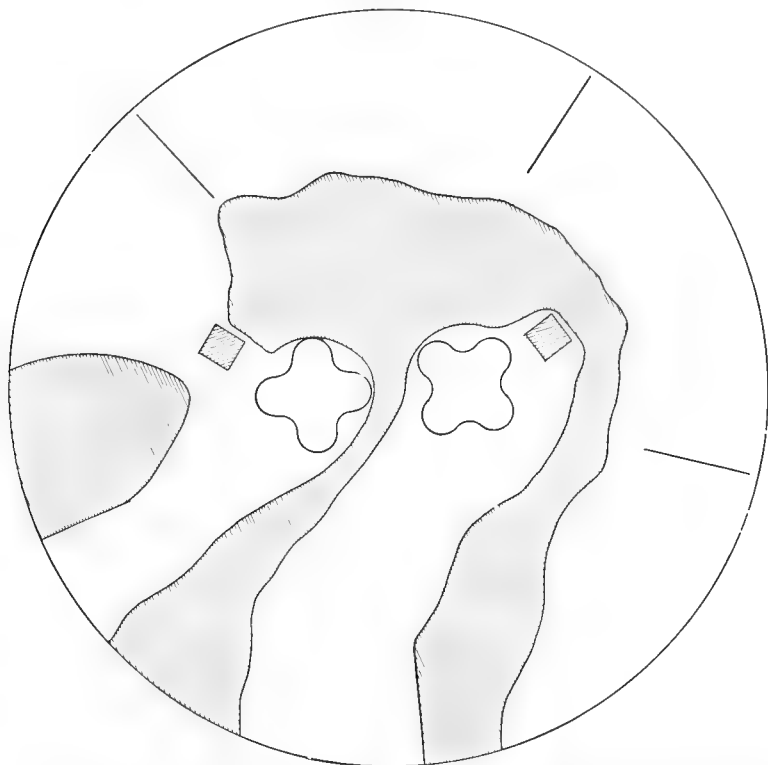

FIG. 106.—Imperfect working, due to overloading churn, and causing a portion of the butter to fall over the rolls without being worked, has a tendency to cause mottles and uneven distribution of moisture.

season of the year. This is due to the presence of an increased per cent of the low-melting fats in butter. The butter has a tendency to be slushy or soft and the granules of salt appear to be imbedded in the butter and do not dissolve as readily.

This defect may be overcome by churning at a sufficiently low temperature. The butter granules will then gather into a

firm enough mass to be efficiently worked. In small creameries where only one or two churnings are to be made the butter can be worked enough to mix the salt thoroughly throughout the mass and permitted to stand for an hour, when the working may

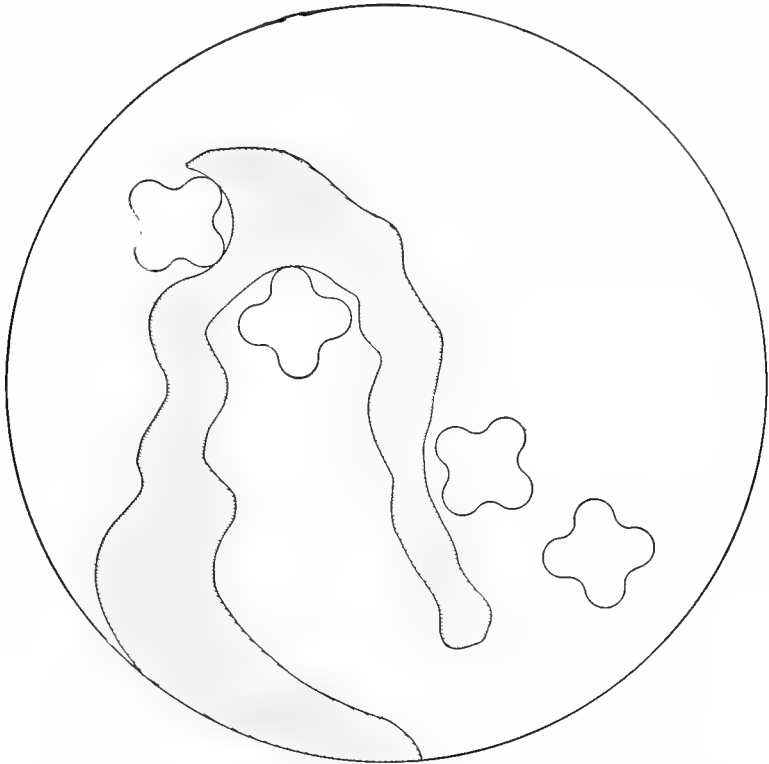

FIG. 107.—Imperfect working, due to overloading churn, and causing a portion of the butter to fall over the rolls without being worked, has a tendency to cause mottles and uneven distribution of moisture.

be completed. This is a method that has been used by some buttermakers for a great many years.

The system used in Denmark a number of years ago, when one of the authors was visiting that country investigating creamery conditions, was to mix the salt thoroughly with the butter on the table worker; then cut the butter up into large rolls and place

it in a tank of water at a temperature of 60° F., and permit it to stand there for two hours; then take the butter out and finish working it. This had the effect of giving the entire mass of butter a uniform temperature and it gave sufficient time to get the salt quite thoroughly dissolved before completion of the final working.

Quite a common cause of mottles, particularly in the summer months, is the overloading of churns. Part of the butter falls over the rolls instead of passing through them. Working butter under these conditions will not, as a rule, produce either a uniform color or a uniform distribution of moisture. Where the rolls are out of alignment it also has a tendency to result in uneven working and thus cause mottles.

Washing the butter with very cold water which chills the surface of the granules also has a tendency to produce mottles. Butter does not appear mottled when first taken from the churn. On standing the more loosely held large water droplets run together into larger aggregates and the portions of the butter containing these fewer but larger droplets show deeper yellow in color.

Prevention of Mottles in Butter.—To state the cause or causes of a defect is often to suggest the remedy or remedies, in a large measure. Unsalted butter is never mottled. This is, in itself, very suggestive. It is well known to experienced creamerymen, and has been taught in our dairy schools for years, that butter will be neither mottled nor streaked if the salt is thoroughly dissolved and the brine evenly distributed and incorporated in fine particles or droplets in the butter by the time we are through working it. There are several means which further this end, and these may be briefly stated as follows:

Have the cream at the right temperature for churning. The butter will then come in good condition. It will be reasonably firm and the buttermilk can be washed out of it thoroughly.

Have the wash-water at the right temperature, so that the butter will be in good condition for working. It can then be worked sufficiently to insure the end sought without injuring the grain and body of the butter.

See that the worker is in good condition. The space between the rolls, from end to end of the churn, should be the same; they should be properly set and in perfect alignment, and there should be no looseness in the bearings and no slipping. The rolls should be straight or without any warps in them, and so set that the elevations on the one meet the grooves of the other.

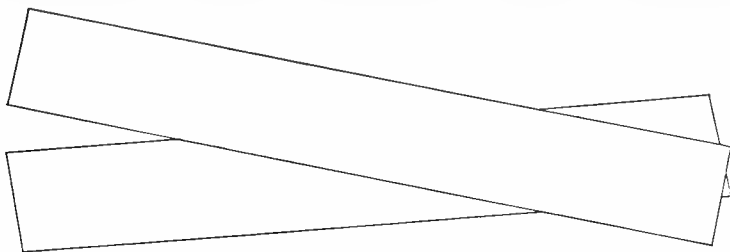

FIG. 108—Rolls out of alignment.

The same care must be taken with regard to the relation of the roll to the shelf in single-roll churns.

Use a good quality of salt that will dissolve readily, and distribute it in the butter as evenly as possible from end to end of the churn.

Do not make too large a churning. This means overloading



FIG. 109.—Rolls perfect.

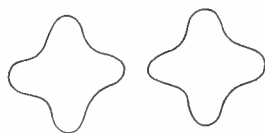

FIG. 110—Rolls not meshing, causing imperfect working.

the workers, and as a consequence part of the butter falls over the rolls and is not worked.

If mottles develop in butter they can be eliminated by reworking it. But this is a remedy that it should not be necessary to apply very often.

Curdy Specks in Butter.—Curdy specks are not, properly speaking, mottles. We should make a sharp distinction between

the two. Curdy specks, as the term implies, are small white particles of curd throughout the butter that are visible to the naked eye. Overripening of either the starter or the cream may, and probably will, produce curd particles that will show in the butter, especially if the cream is not strained into the churn through a fine strainer. Avoid these faulty conditions; break up and mix the starter thoroughly before putting it into the cream; and strain the starter into the cream and the cream into the churn.

To insure uniform salting it is advisable to bring the butter up on the shelf and rolls, make a trench in it from end to end of the churn—leaving both ends closed—and distribute the salt evenly along the trench. Should the butter be in a very firm condition a little water should be added to the salt. The trench is then closed so as to cover the butter before the workers are started.

As butter is worked it becomes an aggregation of butter granules with the intervening spaces occupied by water, curd and air. The more butter is worked the smaller the intervening spaces. On the broken surfaces of worked butter and under the microscope the water appears in the form of round droplets. The less the butter is worked the larger the drops and the more ragged the break or grain. The more the butter is worked the smaller the droplets of water and the shorter the grain. If the working of butter continues, air to the extent of 10 per cent or less by volume is incorporated.

When a piece of butter is torn from the partly worked mass its broken surface is very irregular and shows large drops of water, like tears. Upon squeezing, a shower of water falls out of the butter. If packed in this condition the butter would leak. As the working progresses the drops become smaller and smaller and fewer can be squeezed out of a piece. The working has produced the desired end when the broken surface sparkles with small droplets of water like pinheads and only two or three drops fall out upon squeezing. If packed at this stage the butter has a beautiful grain and does not leak; but if worked beyond this point the droplets of water disappear, the grain becomes short

and the butter becomes greasy, air is incorporated, and the color is light, dull and lusterless. Such butter is overworked and keeps poorly.

The process of working grinds up the water in the butter into smaller and smaller drops. In a leaky butter the water is present in large drops; in a dry butter it is present in small but numerous drops. Repeated working does not injure the grain so long as drops of water can be seen on the torn surface. Logically the working of butter should be continued until the butter is not leaky and stopped before it is dry and sticky.

Brine-salting. Brine-salting is not as a rule practiced in creameries. It is too expensive a method of salting, and also too laborious. By salting butter with brine it is hardly possible to get in salt enough to suit the American butter markets, 2 per cent being about the maximum amount of salt that can be incorporated by the brine method.

In some instances, brine-salting has been recommended. If a light mild taste is desired, the brine method may give good results. The greatest advantages of brine-salting are that mottles in butter are practically avoided, and that the overrun is usually increased a trifle. Especially is this so if the temperature of the brine is medium high when added to the butter. In order to get enough salt (2 per cent) into the butter by the brine method, it is necessary to churn it considerably in the brine and to use two sets of brine. When brine is first added the butter already contains considerable water. This water practically has to be replaced by brine. This is difficult to do, especially if the butter has been overchurned a trifle.

Churning the butter in the first brine will soon dilute the brine to such an extent that it will impart but little saltiness to the butter. For this reason this first brine should be removed and another one added, and the butter churned again in this brine. This last brine will have very little curd in it, and can be saved until the following day and then used as the first brine. The first brine may be used each day for soaking tubs.

It is essential to leave the brine on the butter for from five to fifteen minutes. Churning excessively in the brine, espe-

cially if butter is medium soft, will cause too much water to be incorporated in the butter. After the butter has been exposed to the second brine the proper length of time, it should be drawn off and the butter worked in the usual manner. Less working is usually given to butter which has been salted by the brine method. It should be worked enough to distribute the brine evenly in the butter, and to bring the butter into a compact form. If the butter salted by the brine method is not worked sufficiently, it will become streaky in color after standing.

SALT TEST

Principle of the Test. The reagent used is a solution of silver nitrate (AgNO_3), and the indicator is a solution of potassium chromate (K_2CrO_4). The silver nitrate will combine with either common salt (NaCl) or potassium chromate, but it has the stronger affinity for salt. Hence, if we add a few drops of the potassium chromate to a solution of common salt, and then gradually add silver nitrate solution, the silver nitrate will combine with the salt, forming white or colorless compounds. But as soon as the salt is all used or taken up the silver nitrate combines with the indicator, potassium chromate, producing a brick-red compound.

Chemical Changes that Take Place.—First, as long as there is free salt: AgNO_3 (silver nitrate) + NaCl (common salt) = AgCl (silver chloride) + NaNO_3 (sodium nitrate). No colored substances formed. Second, after all the salt has been acted upon— $2\text{AgNO}_3 + \text{K}_2\text{CrO}_4$ (potassium chromate) = Ag_2CrO_4 (silver chromate, brick-red) + 2KNO_3 . Brick-red color produced.

Proportions in which Silver Nitrate and Salt Combine with Each Other.—

Molecular weight of silver nitrate,

$$\text{AgNO}_3 = 108 + 14 + 3 \times 16 = 170$$

Molecular weight of common salt,

$$\text{NaCl} = 23 + 35.5 = 58.5$$

Both are univalent.

Hence,

58.5 grams salt combine with 170 grams silver nitrate.

1 gram salt combines with $\frac{170}{58.5} = 2.906$ grams silver nitrate,

or

.01 gram salt combines with .02906 gram silver nitrate.

Features of Practical Salt Tests. -The same principle applies to the various salt tests. In the different practical tests, combinations are worked out which enable us to read the per cent of salt directly, without having to make any mathematical calculations.

The following combination enables us to read the per cent of salt in butter directly:

(1) 29.06 (= 29.0) grams of silver nitrate in a solution made up to 1000 c.c.

(2) Burette for silver nitrate solution graduated in cubic centimeters and tenths of a cubic centimeter.

(3) 10 grams of butter, with the salt solution from it made up to 250 c.c.

(4) 25 c.c. of the salt solution, taken by means of a 25 c.c. pipette, that is, a tenth of the salt solution, or a tenth of the salt in the 10-gram sample of butter.

In 1000 c.c. of silver nitrate solution there are 29.06 grams of silver nitrate.

In 1 c.c. of silver nitrate solution there is .02906 gram silver nitrate.

But we have already shown that .02906 gram silver nitrate reacts with .01 gram of salt.

.01 gram salt in 25 c.c. salt solution = .1 gram salt in 250 c.c. of salt solution, or in 10 grams butter, which is 1 per cent of salt.

Hence, each cubic centimeter of the silver nitrate solution required in making the test indicates 1.0 per cent of salt in the butter.

To Make a Salt Test. Either weigh out 10 grams of butter, or take the residue from the 10 grams of butter used in the moisture test; and rinse thoroughly into a suitable flask, with a 250 c.c. mark on it, using distilled water at a temperature of 110° to 120° F. for the purpose, and making up to 250 c.c. with distilled water at the same temperature. Mix thoroughly to dissolve all the salt.

25 c.c. of the salt solution are then transferred to a white enamel cup, and to this are added 2 to 3 drops of indicator (a 10 per cent solution of potassium chromate) from a brown glass dropping bottle.

The silver nitrate solution is then added from a burette, and mixed as it is added, until a permanent, light brick-red color appears.

Note the quantity of silver nitrate solution required to make the test. If, for example, it requires 2.7 c.c. of silver nitrate solution to make the test, this indicates that there is 2.7 per cent of salt in the butter; if it takes 3.8 c.c. of silver nitrate solution, the per cent of salt in the butter is 3.8, etc.

Note.—If the salt solution were made up to 100 c.c. instead of 250 c.c., we could take 10 c.c. instead of 25 c.c. of this solution to a test and read the per cent of salt direct, just as above. In both cases we take a tenth of the solution or a tenth of the salt in the 10-gram sample of butter.

Another combination that will read the per cent of salt directly:

(1) A tenth normal ($N/10$) solution of silver nitrate, that is, 17 grams of silver nitrate in 1000 c.c. of the solution. (The molecular weight of silver nitrate being 170, there are 170 grams in 1000 c.c. of a normal solution, and a tenth of this in a tenth normal solution.)

(2) 10 grams of butter, the salt in it, being dissolved in 300 c.c. of water.

(3) By means of a 17.6 c.c. pipette we take 17.5 c.c. of the salt solution to a test.

Each c.c. of silver nitrate solution required to make the test indicates 1 per cent of salt in the butter.

Distilled water should be used in making the reagents and for the test. The reagents should be kept in brown glass bottles and out of strong light.

It is not advisable to make up more than about a month's supply of silver nitrate solution at a time.

WORKING OF BUTTER

Objects.—The objects of working butter are:

(1) To distribute the salt and brine evenly in the butter. The number of revolutions in the churn necessary to accomplish this will vary somewhat according to the conditions of the butter, and according to the kind of butter-workers employed. If the butter is of medium firmness, about twelve revolutions in the Victor Combined Churn will usually distribute the salt properly, providing the working is well distributed over the working period. It used to be, and is still, the practice in creameries to add the salt while the butter is in a hard granular condition, and then rotate the churn several times in slow gear without putting the workers in gear. This is done in order to mix the salt thoroughly without working. Then it is allowed to stand for five or ten minutes, then worked about four revolutions and allowed to stand a little while again, then the working is completed by allowing the churn to revolve four or five times more, or as many as is deemed necessary to bring the butter into proper condition.

It has, however, been demonstrated that it is not advisable to add the salt while the butter is in this hard granular form. The butter should be united into larger irregular granules before the salt is added. If the salt is added to the butter in a more or less gathered condition, the workers should be put in gear at once, for otherwise the salt will be scattered on the inside of the churn. Butter can be worked three or four revolutions and then allowed to stand until the salt is almost dissolved, at which time the working can be completed by revolving the churn four or five revolutions more. Some prefer to work a little more than ten revolutions in order to be sure that the salt has been evenly distributed.

If the Disbrow churn is being used, it is necessary to work the butter a greater number of revolutions than that recommended when the Victor churn is used. In the Victor churn the butter is virtually worked twice at every revolution, while in the Disbrow churn the butter is only worked once for about three-quarters of a revolution. From sixteen to twenty revolutions of the Disbrow churn usually mix the salt with the butter properly. It is impossible to state exactly the number of revo-

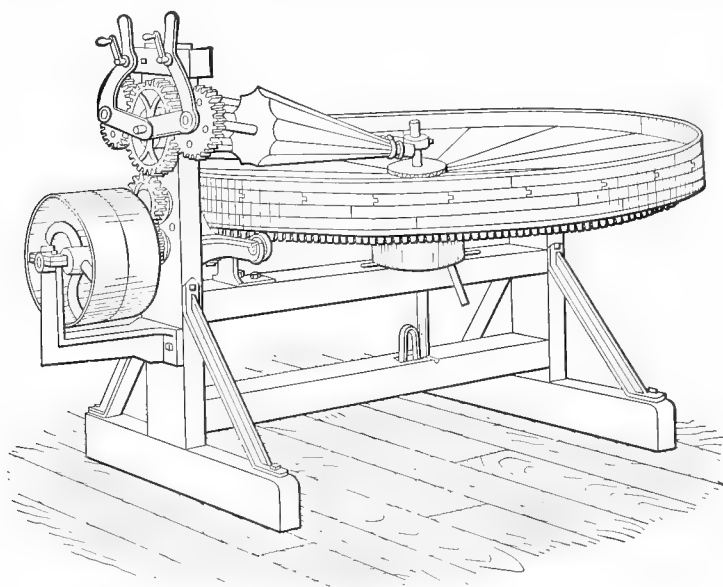

FIG. 111. Old-style table butter-worker.

lutions butter should be worked, as it varies according to different conditions.

(2) Butter is worked in order to bring it into a compact form. When butter is soft it usually gathers, but if it is present in the firm granular condition, which condition results from churning thin cream and washing the butter in cold water, it is more or less difficult to get the little granules together. More working is necessary when the butter is in such a condition.

(3) The working of butter also expresses an excessive amount

of buttermilk or water that may be present. By adding salt and then working the butter, the excess of buttermilk is largely eliminated. Especially is this so when the butter is in a medium firm condition. Working is also effective in removing water from the butter.

Moisture Tests of Butter.—1. *Official Method.*—"Weigh 1.5 to 2.5 grams of the sample into a flat-bottomed dish, having a surface of at least 20 sq. cm., dry at the temperature of boiling water and weigh at hourly intervals until the weight becomes constant. The use of clean dry sand or asbestos is admissible."

2. *Rapid Method.*—The moisture tests used in creameries differ from the official method mainly, in the speedier, less refined scales used, and larger sample taken to a test, and in the adoption of a higher temperature for driving the moisture off more quickly. The results, when the work is carefully done, are quite reliable.

To Make a Test.—Obtain an average composite sample from the churn, through scraping off the surface of the butter with a ladle and taking samples from end to end of the churn by means of a dry, warm spatula or spoon. In case of a tub take a core with a trier, extending diagonally from top to bottom of the package, and make up a composite sample from sections of this. The composite sample jar should have a close cover.

Carefully warm the sample until the butter is of a pasty or creamy consistency and mix well with a spatula.

Weigh 10 grams into a well-dried light aluminum cup about $2\frac{1}{2}$ in. in diameter. Place the cup on an asbestos sheet over a low gas or alcohol-lamp flame, or hold over a low, direct flame. Do not heat too rapidly. The heating process is complete when foaming ceases and a light-brown color appears, and should not be carried beyond this stage.

Allow the cup and contents to cool, then reweigh. The percentage loss in weight indicates the per cent of moisture. Most scales read this direct.

CHAPTER XIX

PREPARING BUTTER FOR MARKET AND PREVENTION OF MOLD

IN the preparation of butter for market, care should be exercised to see that only those woods which will not affect the flavor of the butter are used in the package. From practical

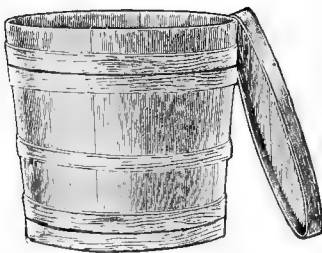

FIG. 112.—Elgin style butter-tub.



FIG. 113.—Bradley butter-boxes.

experience and from various experiments it has been found that ash and spruce are the most suitable woods in which to pack butter to be delivered to the market. In the eastern markets a decided preference is given to the 60-pound ash tub. Prior to the use of this tub the old-style firkin was used. Possibly the

reason for the preference given to the 60-pound tub in the eastern market lies in the fact that many dealers have so arranged their refrigerators that they have a space in which the tub fits. Custom, based upon long use of the 60-pound tub, has created such a decided preference for butter packed in this manner that it will sell in the eastern market at from half a cent to one cent more a pound than if packed in a cubical box.

The Pacific Coast markets, on the other hand, have a decided

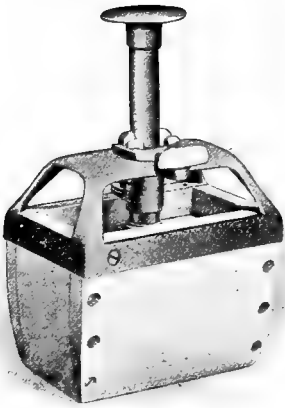
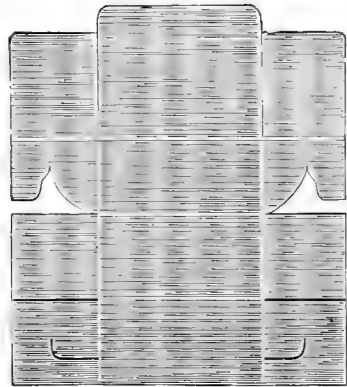
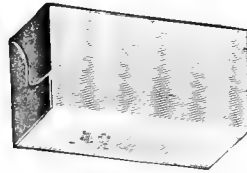

FIG. 114.—The Eureka hand butter-printer



Open.



Folded.

FIG. 115.—Butter cartons.

preference for the cubical spruce box, and will pay a premium for butter packed in that style.

If the butter is to be cut into prints, as is done by a great many dealers at the present time, the cubical box has an advantage over the tub. Butter so packed will cut into prints with less waste.

In addition to spruce for the cubical box, Southern poplar has been used quite extensively. A box of the following dimen-

sions holds 65 pounds of butter, and has given excellent satisfaction for packing butter that is to be recut into prints. The dimensions are, $14\frac{1}{2}$ by $13\frac{1}{2}$ by $10\frac{1}{2}$ inches, $\frac{9}{16}$ inch ends and sides, $\frac{3}{8}$ inch top and bottom.

For the Pacific Coast trade, boxes holding as much as 90 pounds are used by some of our larger creameries. Boxes of this size are not used to any extent in the eastern markets.

For packing butter on the farm, earthen jars give excellent satisfaction, particularly if they are well glazed. Due to the possibility of breakage, such jars are not used to any extent for shipping butter. Earthen jars or crocks are very heavy and easily broken during transportation.

For shipping in small packages of different sizes, the spruce package is most commonly used. Some tubs manufactured for this purpose hold 10, 20 and 30 pounds. The spruce tub is also made in larger sizes, holding from 60 to 65 pounds.

While spruce will not flavor butter if the tub is rightly prepared, the disadvantage of the spruce package is that it soils very easily on the outside and gives the package an unsightly appearance.

In Canada, New Zealand and Australia the cubical box is used exclusively. These boxes are made to hold 56 pounds of butter. Sometimes double covers are used.

Storing Butter in Creameries.—The temperature of the room in which butter is stored should be as low as conditions will permit. In local creameries a temperature of 40° or lower should be maintained. In small creameries the butter is usually kept at the creamery from three to six days. In some sections of the country railroads carry refrigeration cars weekly; in others semi-weekly. Hence, it is necessary to store butter at as low a temperature as possible while it is waiting to be shipped. The refrigerator in which the butter is kept at the creamery should be as pure and dry as possible. Damp places are favorable to the production of molds. Neither vegetables nor foods of other kinds should be allowed in the refrigerator with butter, as they are likely to impart foreign flavors to it.

All large creameries, the so-called centralizers, are equipped

with mechanical refrigeration for cooling purposes. Hence, they are able to keep the storage room for butter at any temperature desired. On the contrary, many of the small creameries have to depend exclusively upon ice for refrigerating purposes.



FIG. 116.—Tub-fasteners; common tins.

In cases where ice is not available, water can be utilized for the purpose of cooling. Water in the creamery can be forced through galvanized iron tanks, which are properly placed in the butter storage room or refrigerator so as to allow as much cooling sur-



FIG. 117.—Tub-fasteners: tin and tack combined.

face in the butter room as possible. This is merely a makeshift for ice and will not cool the room so effectively, but in the absence of ice this is better than no cooling at all.

Cost of Manufacturing Butter.—This will depend upon the



FIG. 118.—Tub-fasteners; riveted.

volume of cream received and the kind of packages in which the butter is to be packed for market. About fifteen years ago the Iowa State Dairy Commissioner investigated this question, and found the cost of manufacturing ranged from 1.2 cents to 6 cents per pound. The creamery where the cost ran up to 6

cents a pound only produced 30,000 pounds of butter per year. The lowest cost of manufacturing was submitted by a co-operative creamery making nearly half a million pounds of butter from whole milk exclusively. The approximate average cost of making butter for the creameries in the State of Iowa at that time was $2\frac{1}{4}$ cents a pound. As labor, coal and all material used in the manufacture of butter have greatly advanced, the cost at the present time in the small creameries will exceed the above figures.

In a medium-sized central plant the cost should not exceed 2 cents a pound. This does not include the package. It includes the cost of factory supplies, such as salt, butter-coloring, milk for starters, power, labor, refrigeration, factory incidentals, factory maintenance and depreciation. The cost of package will depend en-

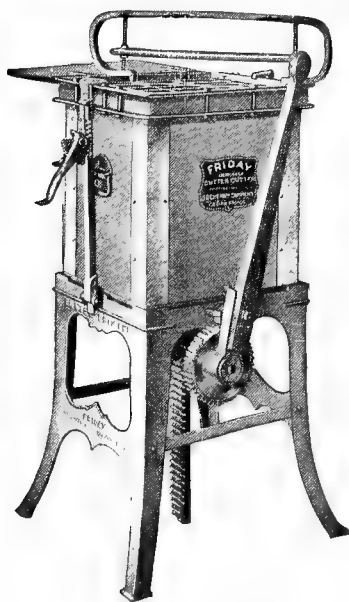

FIG. 119.—Friday printer.
(J. G. Cherry Co.).

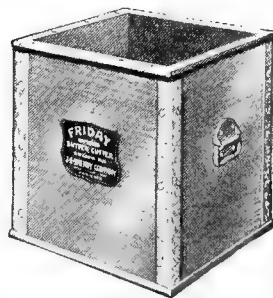

FIG. 120.—Friday box.

tirely upon the kind of package used and the labor necessary to pack. If the package used is the 60 or 65 pound tub or cubical box, the cost of package and labor involved will not be very great. If the butter is to be put up in fourth-pound or pound prints, the cost will be much greater. At the present time, the authors would place the cost, with the package included, at $3\frac{1}{2}$ cents per pound.

During the fall and winter, many creameries where the milk supply is rather low print all their butter. Many of the commission men will pay a premium of 1 cent a pound for butter

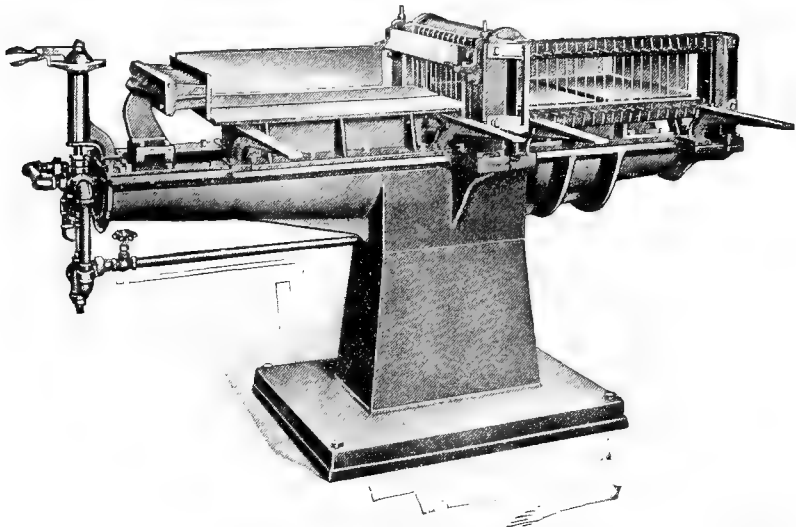

FIG. 121.—Miller hydraulic cutter for hard and frozen butter. (L. C. Sharp Mfg. Co.).

so packed. The butter-maker has more time at this period and should take advantage of it to put his butter up in neatly packed prints. A creamery should have its own wrapper, and

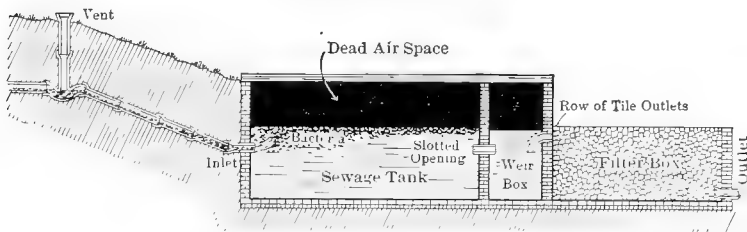

FIG. 122.—Cross-section of a sewage-disposal tank (Wallace's Farmer.)

it should bear the name of the manufacturer. If the butter is good, it will take but a short time for the consumer to become familiar with this brand and a demand for it will eventually be

created. It is essential, however, that we consider the cost of printing the butter and the loss in printing. Some little waste of butter accompanies the printing process. Butter to be printed nicely should be firm but not hard, so that the print may assume its proper shape. Butter should be worked to a point where it is free from loose moisture; otherwise, the loss will be much heavier in printing.

Treatment of Tubs and Boxes.—Investigations were made by Rogers¹ of the different treatments of tubs for the prevention

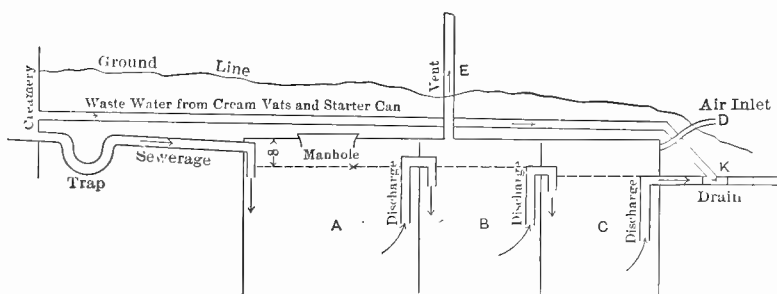

FIG. 123.—Septic tank for creamery sewage disposal. (By Prof. J. Michels.) The tank should be located in the ground with the top within a foot or two of the surface. It may be constructed of planks. Brick, stone, or concrete is preferable for durability. The tank should be built air-tight except in two places, D and E.

of contamination by mold. Comparison was made of the following methods:

- (1) Soaking the tubs overnight in cold water.
- (2) Boiling five minutes in a saturated brine solution and leaving in the brine overnight.
- (3) Soaking overnight in a brine containing 9 per cent of commercial formalin (which is a 40 per cent solution of formaldehyde).
- (4) Coating the tubs on the inside with paraffin.
- (5) Immersing the tubs for a few seconds in paraffin at a temperature of 250° to 260° F.

Rogers comments upon the table giving results of his investigations and makes some general observations, as follows:

¹ Bulletin 89, Bureau of Animal Husbandry, U. S. Dept. of Agriculture.

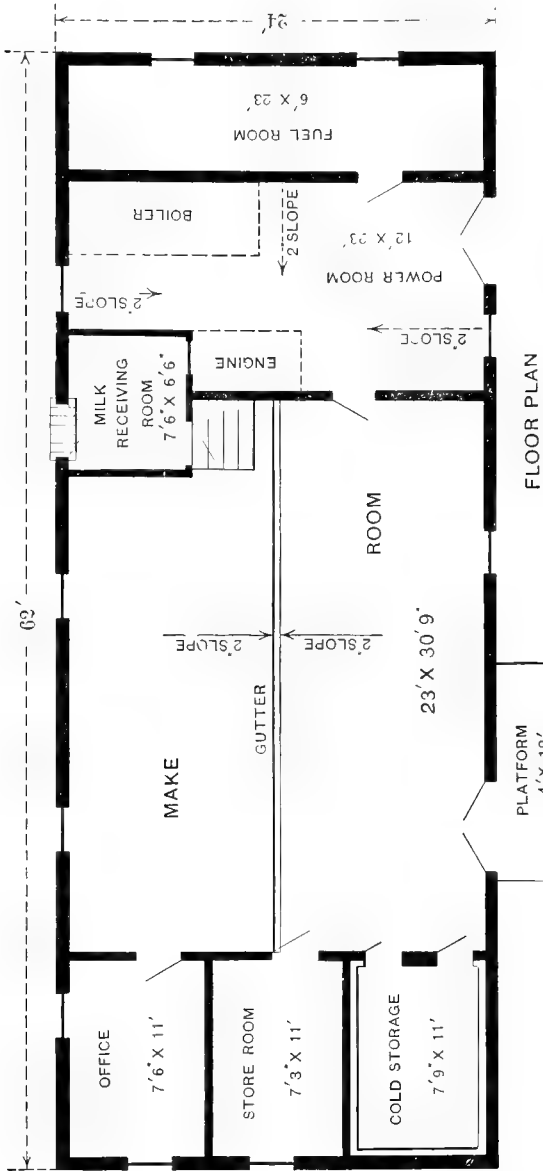

FIG. 124.—Plan of a creamery. Scale $\frac{3}{8}'' = 1'$. Floor plan. (Bul 53, Montana.)

“ It will be seen from this table that all of the untreated tubs became moldy. Of the six tubs treated with hot brine, one was badly molded, one was slightly molded and one had mold on the outside. Of the six tubs soaked in the brine-formaldehyde mixture, one was badly molded. None of the tubs coated with paraffin showed any mold whatever, and the same was true of those dipped in paraffin.

“ To treat tubs by the brine-formaldehyde method or the hot-brine method a vat should be made large enough to hold submerged the tubs used in one day. The cost of either of these two methods is insignificant as the bath may be used repeatedly. The objections to these two methods, in addition to their inefficiency, would probably be found in the discoloring of the wood and, with the hot brine, in the excessive weight and swelling of the tub.”

Paraffining of Tubs.—From the investigations made it would seem that the most efficient method of treating tubs or boxes for the prevention of mold is to paraffin them on the inside.

Before tubs are paraffined they should be thoroughly steamed. In extreme cases, where tubs are very open, it may be necessary to soak them, but only in such cases. Whether soaked or not, the tubs should be steamed just before paraffining them. This swells and tightens the tub, and heats the wood and opens its pores so that the paraffin will penetrate it sufficiently and at the same time form a nice, smooth coating. The paraffin should be heated to a temperature of about 250° F. If much below this it is apt to cause the coating to be thick and patchy, and if much above it is likely to soak into the wood and not form a proper coating. The easiest way to heat the paraffin in a creamery is to place a steam coil in the bottom of the paraffin tank with a valve or dripclock on it to allow the escape of condensed steam.

Where the work is done in a small way, the paraffin can be applied in one of two ways—either by means of a brush or by pouring some paraffin into the tub, rotating it to cover the whole surface and then placing it mouth downward to drain the surplus paraffin from it. But in a creamery of any size a suitable

apparatus for spraying the inside of the tub with paraffin should be used.

As it only requires about 3 ounces of paraffin for a tub that holds 60 to 65 pounds of butter the cost is not great, and the work entailed in paraffining is no greater than that of either of the other treatments mentioned.

Paraffin furnishes no food for molds; if there be any mold organisms on the wood they will probably be destroyed to a very great extent, if not entirely, either by the hot paraffin spray or through the exclusion of the air which they require for growth; and, even failing this, the coating of paraffin shuts them off from the parchment paper and the butter. Furthermore, as paraffin is impervious to water, the space between the liner and the tub remains filled with water or brine which excludes the air and retards or prevents the development of any molds that may be present.

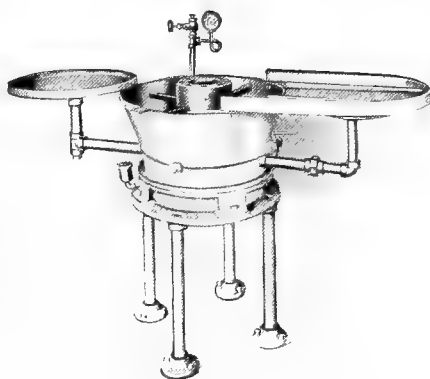

FIG. 125.—Tub paraffiner (Creamery Package Mfg. Co.).

Paraffining Tubs Reduces Loss from Shrinkage.—Another strong inducement to paraffin tubs is the saving in shrinkage, due to the prevention of the escape of moisture. In an experiment made by Rogers, during his investigations, he found the shrinkage, during a period of eight days in creamery storage and in transit, on butter packed in paraffined tubs and in tubs soaked in brine, respectively, to be as follows:

Treatment of Tubs	Number of Tubs	WEIGHT OF BUTTER (POUNDS)		Shrinkage Pounds
		When Packed	After Eight Days	
Paraffined.....	12	757 $\frac{3}{4}$	756	1 $\frac{3}{4}$
Soaked.....	12	766 $\frac{3}{4}$	759	7 $\frac{3}{4}$

Thus the saving in shrinkage, through paraffining, was 6 pounds on 12 tubs or half a pound per tub.

With unsoaked, paraffined tubs the tare should be marked on the package. Such tubs may be as much as 2 pounds lighter than soaked tubs.

Treatment of Parchment Paper.—As parchment paper is a good medium for the growth of mold organisms and may harbor the spores, though showing no growth of mold, it is quite as important to treat it as to treat the tubs for the prevention of mold. One method of treatment for parchment paper is to soak it for at least ten minutes, before using, in a saturated solution of brine at or near the boiling point. Russell and Hastings¹ say, "A most efficient way of treating paper, either for tub liners or print wrappers, is to place same in boiling water for a few minutes." As formalin is very destructive of mold, another very efficient treatment for parchment paper is to soak it in cold brine or water containing formalin.

YEASTS AND MOLDS IN BUTTER

Bacteria are not the only micro-organisms found in milk and its products. There are also yeasts and molds, the mold most commonly found being *Oidium* (plural *Oidia*) *lactis*, or the ordinary white mold which frequently appears on the surface of sour milk or cream.

What may be desirable in connection with one dairy product may be the reverse with regard to another. For instance, Freudenreich and Marchel have shown that in the ripening of certain Swiss and Belgian soft cheeses the common white mold (*Oidium lactis*) plays a principal part. In these products its presence is not only desirable but necessary.

On the other hand, it is found that where yeasts and molds are present to any considerable extent in butter, it is not nearly so likely to possess good keeping qualities as if they were not present, even though its flavor when made be quite satisfactory. They may be present in cream in quite large numbers, when it

¹ Dairy Bacteriology.

arrives at the creamery, but if it be efficiently pasteurized and kept from subsequent contamination, the mere fact of their presence in the raw cream does not mean that the butter made from this cream will be either defective in flavor, when made, or lacking in keeping quality.

A study, by Bouska and Brown, of a large number of packages of butter placed in cold storage showed that the number of yeasts and molds present in butter, when made, is a fair criterion from which to judge of its keeping quality. To put it in another way, the number of yeasts and molds present in butter, as it comes from the churn, is a good indication as to the efficiency of pasteurization and the subsequent handling of the cream to prevent re-contamination.

The laboratory of the American Association of Creamery Butter Manufacturers has, for a number of years, made counts of the number of yeasts and molds in samples of butter sent in by its members, for this purpose. As a result of this work, and the advice and assistance given, many of the creameries have so improved their methods and equipment as to practically eliminate yeasts and molds from their butter, and make a product possessing good flavor when fresh and good keeping qualities.

Where the number of yeasts and molds in butter is reduced to ten or less per cubic centimeter—colonies counted without the aid of a magnifying glass—this is regarded as excellent work; and several of the creameries have reached this stage of efficiency. A strong effort should be made by every creamery to keep the number of yeasts and molds as low as possible, that is, to thoroughly pasteurize the cream and prevent subsequent contamination.

Whether or not the yeasts and molds present in butter are a direct cause of deterioration is not definitely known, although there are reasons for believing that this is not necessarily so. Hastings found yeasts to be present in butter which won first prize in a Wisconsin educational contest. The presence in butter of yeasts and molds in large numbers usually means the presence of other undesirable organisms in the cream, due to one or more of the following causes:

(1) Inefficient pasteurization, the pasteurizing temperature being too low or not maintained throughout the run, or some of the cream at the beginning or end of a run not being pasteurized.

(2) Lack of thorough cleansing or sterilizing of the utensils and conduits—pumps, vats, faucets, pipes, churns, etc.

(3) The use of a defective starter—one that has become contaminated with yeasts, molds and undesirable bacteria. Once this occurs it will propagate itself from day to day until there is a change of mother-starter.

It must be remembered that although the pasteurizing may be thoroughly done its good effects may be largely nullified through subsequent contamination. Hence the final test of the efficiency of pasteurization, in creamery work, should really be the freedom of the butter from the ferments which cannot fail to be eliminated by proper pasteurization, and the processes that should accompany it. Another test of the thoroughness of the pasteurization of milk or cream for butter-making purposes is the Storch test, which is outlined in the chapter on Pasteurization.

MOLD ON BUTTER

The development of mold on butter constitutes a defect that causes large losses. Mold not only greatly mars the appearance of a package of butter but affects its flavor as well. It develops not only on the outside of butter but along the surfaces of any crevices or pockets there may be and works its way into the butter. Upon this point we quote Thom and Shaw of the U. S. Department of Agriculture:¹ "In closed packages, wet or damp cellars, or carelessly packed masses with cracks or fissures in which moisture collects, mold may seriously injure the appearance of butter packages or actually induce great changes in the butter itself." No score is given to moldy butter.

As to the character of butter that affords the most favorable conditions for the growth and development of mold organisms, if any be present, these same authorities say, "Excess of curd

¹ "Moldiness in Butter," Journal of Agricultural Research, Vol. III, No. 4.

favors mold growth. Well-washed butter is less subject to mold. Leaky butter—butter from which water or buttermilk exudes and collects in the wrappings or the container—furnishes the best conditions for the beginning of mold growth. From these wet areas colonies may spread to the butter itself.” These facts point to the necessity of churning at the right temperature, washing the butter properly with water at the right temperature and properly working it, so as to free the butter of excess of curdy matter and buttermilk and make a butter that is not porous but close, and in which the moisture is incorporated in fine particles instead of larger droplets. They also show the importance of packing butter closely so as to free it of air pockets and fissures.

Conditions Favorable to the Growth of Molds.—Like all other plants, large and small, molds require certain conditions for growth. They differ from ordinary plants in that they do not require light for their growth, but grow rather better in the absence of light. They require suitable food, but find this in or on almost any organic matter, animal or vegetable, such as bread, meat, leather, cheese, etc. They require moisture, and hence develop rapidly in damp rooms and on damp surfaces. They require a certain amount of air and will not grow in the absence of it. As to temperature, while they develop most rapidly in a reasonably warm atmosphere, many of them can accommodate themselves to a wide range of temperature.

Discolorations.—The colors produced by molds range from such light colors as orange-yellow to such dark colors as green, a smudged or smoke color and black, according to the type of mold present.

Propagation of Molds.—Molds reproduce themselves by means of buds (conidia) and spores, and these float so freely in the air that practically no exposed surface is entirely free of them, and all they need for development is the suitable conditions we have already outlined.

Sources of Mold on Butter.—The two most common sources of mold on butter are the tubs or boxes in which it is packed and the parchment paper. Wood that is green, sappy or damp

is a good medium for the growth of mold; so also is parchment paper, particularly if it be at all damp. Hence the tubs should be made of well-seasoned wood of good quality, and both the tubs and the parchment paper should be kept in a clean, dry place. In the planing of the tub staves the planer should be sufficiently sharp to insure a smooth surface.

CHAPTER XX

THE COMPOSITION OF BUTTER AND FACTORS THAT INFLUENCE ITS CONTROL

Acts and Rulings as to Composition of Butter.—We have only one Federal statute that deals specifically with the composition of butter, and this applies only to the District of Columbia. This Act was approved March 2, 1895, and requires that butter must contain 83 per cent of milk-fat, not more than 12 per cent of water and not more than 5 per cent of salt.

No attempt has been made to enforce the above statute, no doubt due to the fact that creameries could not comply with the same under the ordinary methods of butter-making.

Act of August 2, 1886, defines butter as follows:

“That for the purpose of this Act the word ‘butter’ shall be understood to mean the food product usually known as butter, and which is made exclusively from milk or cream, or both, with or without common salt, and with or without additional coloring matter.”

Act of May 9, 1902, known as the “adulterated” law, reads as follows: “Adulterated butter” is hereby defined to mean a grade of butter produced by mixing, reworking, rechurning in milk or cream, refining, or in any way producing a uniform, purified, or improved product from different lots or parcels of melted or unmelted butter or butter-fat, in which any acid, alkali, chemical, or any substance whatever is introduced or used for the purpose or with the effect of deodorizing or removing therefrom rancidity, or any butter-fat with which there is mixed any substance foreign to butter as herein defined, with intent or effect of cheapening in cost the product or any butter in the manufacture or manipulation of which any process or

material is used with intent or effect of causing the absorption of abnormal quantities of water, milk, or cream; that "process butter" or "renovated butter" is hereby defined to mean butter which has been subjected to any process by which it is melted, clarified or refined and made to resemble genuine butter, always excepting 'adulterated butter' as defined by this Act."

The ruling made by the Secretary of the Treasury, the Secretary of Agriculture and the Secretary of Labor fixes the legal standard of moisture in butter as 15.99 per cent. According to

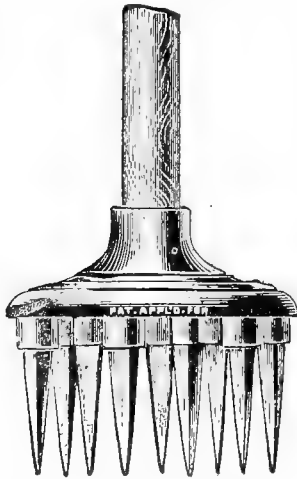

FIG. 126.—Ice-crusher.

this ruling, butter that contains 16 per cent would be classified as adulterated butter. No allowance is made for chemical errors in testing. While the chemists allow .2 per cent for error, the Internal Revenue, in enforcing this ruling, makes no such allowance. In some districts the courts have sustained the Internal Revenue Department; in other districts they have not. Some judges have ruled that the Congress of the United States is the only body that has the power to fix definite standards for food products. No doubt the Act of May 9, 1902, refers to

methods that were used at that time for the purpose of incorporating abnormal quantities of water.

Compounds for Increasing Yield of Butter.—The Internal Revenue ruling is based entirely upon the "adulterated" act. Prior to the adoption of the law of 1902 no attempt was made by the government to enforce any regulations concerning the manufacture of butter. At this early period various compounds were used for increasing the yield of butter.

In 1893 the United States Department of Agriculture published *Farmer's Bulletin No. 12*, "Nostrums for Increasing Yield of Butter," by Dr. H. W. Wiley, Chief of the Bureau of

Chemistry. The analyses published in this bulletin reveal the fact that the compounds used increased the yield of butter. Analyses reported by Dr. Wiley:

Water	Fat	Ash (Salt)	Casein
49.55	45.45	1.34	3.36
31.93	67.30	.15	.63

In 1900 experiments were carried on by Dr. J. B. Weems and Prof. F. W. Bouska at the Iowa Experiment Station. They tested out a number of compounds for increasing the yield of butter and got the following results:

Water	Fat	Ash (Salt)	Casein
41.54	53.04	2.46	2.96

The second recipe was composed of the following ingredients:

Alumnae pot. sul.....	4 ounces
Gum acacia pure.....	1 ounce
Sacc. lact.....	2 ounces 2 drachms
Pure pepsin.....	5 grains

Giving butter of the following composition:

Water	Fat	Casein	Ash (Salt)
49.64	41.46	5.05	3.84

In addition to the above, samples of suspicious butter were sent to the Station from a Chicago Commission House, which showed,

Water	Fat	Casein	Ash
59.61	21.31	11.72	7.36
42.76	44.92	5.10	7.22

Need for Regulations.—From the above it would seem that there was a necessity for some definite regulations concerning the standard or composition of butter. Possibly the Internal Revenue people, in endeavoring to enforce their ruling of 15.99 per cent, have been rather exacting in some cases where prosecutions have been made.

In many cases, where the butter was found to slightly exceed

the limit set by the Internal Revenue Department, creameries were assessed 10 cents a pound tax on the butter, \$50.00 a month license, or \$600.00 a year, and an additional 50 per cent for not taking out a license. In some of these cases a few pounds of butter were seized from a churning. Many creameries have paid these assessments to avoid the notoriety of going into the courts and defending their rights. Not only did the creamery pay the above tax, but the dealer in butter was assessed \$480.00 for a year's license for handling so-called adulterated butter. Creameries cannot sue the government for the refund of this money. The only way they can get into the courts is to sue the local agent. In many cases that have come up in the courts, expert butter-makers have appeared as witnesses, some in behalf of the government and some in behalf of the creameries. Some butter experts have made affidavits that the composition of butter can be controlled and others have made affidavits that it cannot be controlled. This diversity of opinion among so-called experts no doubt has been due to lack of experience on the part of some of the men testifying. No doubt all witnesses appearing were honest in the testimony given.

Control of Moisture in Butter. -After spending over thirty years in the butter business in various capacities and conducting a vast amount of experimental work in an endeavor to control the composition of butter the authors are convinced that the moisture-content of butter cannot be completely controlled at all times. Extensive investigational work was carried on at the Iowa Experiment Station on this subject from 1901 to 1903. The object of this work was not to incorporate water in butter but to get butter to run uniform in composition throughout the year. Prior to this investigational work the senior author had a number of analyses made of the butter produced in some of the best creameries during the entire year. In this investigation the fat-content, the moisture-content and the salt-content were found to vary greatly. In the winter months the moisture-content might be as low as 10 per cent, and in the summer months as high as 17 per cent. These creameries were not making any effort to control the composition of their butter.

They had their cream in such a condition that it would churn in about forty-five minutes and the butter granules would be so firm that the butter could be worked sufficiently to prevent mottles and leaky butter.

Butter was churned normally to granules about as large as wheat. A number of conditions was responsible for this wide variation in the composi-

tion from season to season, such as washing with too cold water in the winter months and churning at too high a temperature in the summer months.

Feeding cows on dry feed during the winter months has an effect upon the composition of fats. There are more of the high-melting fats present; consequently, the butter has a higher melting point.

In the early days of the creamery business practically all butter was worked on the table worker. It was the custom of many makers to work their butter twice. After having the salt incorporated they would set it in the cooler for three or four hours or leave it until the next day. This had a tendency to make butter with a lower moisture-content, as the second working would invariably start a fresh flow of moisture from the butter.

The invention of the combined churn and other modern creamery machinery enabled the butter-maker more easily to control the composition of the butter. The combined churn has been a great benefit to the creamery industry. It keeps the butter in a more sanitary condition and prevents flies and dirt from coming in contact with it. The butter can be worked in one working so that it will be free from mottles and in a condition to be packed directly in sanitary packages. Hence it is not surprising that the combined churn is being universally adopted throughout the dairy world.

It is only reasonable to suppose that since the adoption of the combined churn the moisture-content of butter would run



FIG. 127.—Rubber mop.

somewhat higher than under the old method of working on the table worker, due to the variation of temperature, which affected the hardness of the butter when it received its second working.

Many of the earlier analyses were of butter that had been manufactured under the earlier conditions outlined here. Hence, it is not surprising that the composition varied greatly.

The composition of butter may vary greatly in different localities. There are two instances that have come under the observation of one of the authors; these will be designated as Creamery A and Creamery B. Both creameries were located in the northern part of Iowa.

Creamery A in the latter part of the month of May, 1908, sent word to the Iowa Experiment Station that they were unable to keep the moisture-content of their butter below 16 per cent. Hence, they naturally feared that their butter would be seized by the Internal Revenue authorities, and that they would be prosecuted for making adulterated butter. They maintained they had had some butter experts there to help them out but that they had failed to accomplish the desired results.

The authorities of the Iowa Experiment Station sent them a graduate of the school, Mr. C. L. Mitchel, who had had a great deal of practical experience before going to college. He found that the butter-maker was churning at as low a temperature as 44° F., and was trying every method that he knew of to hold the moisture below 15.99 per cent, the limit fixed by the Internal Revenue Department. Mr. Mitchel churned out two churnings at the same temperature and got a moisture-content of between 17 and 18 per cent. He therefore changed his methods and raised the temperature to 52° F., and after completing his churning worked the butter through the rolls several times to expel a portion of the moisture before applying the salt. This method worked out very successfully. The rolls expelled considerable moisture before the salt was applied. As soon as the salt was applied it attracted the moisture and the result was that sufficient moisture was easily expelled from the butter to enable him to make butter that contained moisture below the required standard. This method is now practiced in some of the

large creameries, especially in the early spring months when the grass is inclined to be slushy and wet. Butter of this character has a tendency, however, to be slightly greasy or overworked.

Creamery B was situated in the northwestern part of the state. Mr. J. C. Joslyn, who is generally recognized as one of our leading butter authorities, had charge of this plant. Prior to the experience that Mr. Joslyn had with this high moisture he was under the impression that if any butter contained more than 16 per cent moisture, this excess moisture was intentionally worked in by the maker. One day, however, he had a churning where the method as far as he knew was similar to that he had been pursuing to make the best butter. This particular churning of butter, upon testing, showed a moisture-content of 18 per cent. The peculiar thing about this butter was that the moisture was so incorporated that he was unable to expel it, even by reworking the butter. The authors have heard of only a few instances of this kind. The only way whereby Mr. Joslyn succeeded in reducing the moisture was to put the butter in a cooler for two days and then break it up into small pieces and rework it. In this way he was able to reduce the moisture below the point permitted by the government regulation.

One of the authors, in visiting the Experiment Station at Copenhagen, was informed by Dr. Holmes, Dr. Storch's first assistant, that they had found in their educational scoring contest in Denmark a few firkins of butter that ran as high as 18 per cent moisture and were perfect in body and general appearance. They were unable to give any explanation for the occasional production of a churning of this kind. The finding of excessive moisture in butter is not a new experience in the butter business.

ANALYSES OF COMMERCIAL BUTTER PUBLISHED BETWEEN THIRTY AND FORTY YEARS AGO

Blyth says:

“There is no standard followed or fixed with regard to the percentage of water. In those cases in which the fat is below 80 per cent, the deficiency of fat is usually from excess of water,

and seeing the variable quantity of water found in butter, it is wisest not to certify on the grounds of water alone unless there is sufficient to lower the percentage of fat below 80 per cent.

“At the Bath Police Court (January, 1879), a dairyman had been summoned for selling butter, the proximate analysis of which showed a considerable addition of water. An appeal to the Somerset House elicited the following certificate:

“We hereby certify that we have analyzed the butter and declare the result of our analysis to be as follows:

	Per Cent
Water	23.27
Butter-fat	74.69
Salt78
Curd	1.26

“The result of our analyses of numerous samples of ordinary commercial butter obtained from different parts of the country, including the south of England, shows that the portion of water is very variable and that it occasionally amounts to as much as 19 per cent.”

James Bell obtained, for 117 samples of butter collected in various parts of the kingdom, and asserted by him to be genuine, proportions of water varying from 4.15 to 20.75 per cent.

Lewkowitsch in his work says:

“The proportion of water in butter should not exceed 16 per cent.”

He gives the following table to illustrate the amount of water present in butter on the English market:

	No. of Samples Examined	Samples Containing Per Cent of Water		Above 16	Observer
		From 11 to 14	From 10 to 16		
English and foreign	560	83.8	94.2	.9	Vieth
English	143	70.7	85.4	.7	H. D. Richmond
Foreign	417	88.2	97.2	1.0	H. D. Richmond

The above analyses reveal the fact that the moisture-content of butter was as high and as variable as at the present time. Even at that early date Blyth fixed 80 per cent as the minimum fat-content for butter. The composition of butter in the early days was more variable than it is at the present time. This is to be expected from the fact that more efficient machinery and methods are now used for controlling the temperatures, and that butter-makers have a better understanding of the effect of temperature on the control of moisture. Butter made at the present time will undoubtedly compare very favorably with butter made in earlier years.

Standards in Different Countries. Most of the European countries have limited regulations to specifying the moisture-content of butter rather than the fat-content. The International Dairy Congress held in Brussels in 1910 passed resolutions favoring 18 per cent moisture as the maximum amount. England has a 16 per cent moisture regulation for butter, and 24 per cent for blended butter. France has an 18 per cent regulation and Belgium an 18 per cent regulation for moisture. Denmark has a 16 per cent regulation for export and 20 per cent for home consumption. Canada has a 16 per cent regulation. Germany has an 18 per cent regulation for moisture for unsalted butter; for salted butter her standard requires 80 per cent fat and not more than 16 per cent moisture. Italy has an 82 per cent fat regulation. Queensland has a 16 per cent moisture regulation and 80 per cent fat. Victoria has an 80 per cent fat and 16 per cent moisture regulation.

Possibly the reason that some of the European countries have adopted a moisture rather than a fat standard is that it is much easier to make a moisture determination than a fat determination, as in dealing with moisture we are only dealing with one agent, and with the fat determination we have three agents to deal with, the salt, casein and moisture. A 16 per cent moisture and an 80 per cent fat standard for butter would be practically the same. Taking 3 per cent for salt and 1 per cent for casein, this would leave 80 per cent fat, providing the moisture were carried to the limit, which is not a wise or a safe proposition.

The consumer in purchasing butter buys it for its food value or fat-content. Therefore, it is only reasonable that the creamerymen should be willing to have all their butter contain at least 80 per cent fat. No doubt the reason so many of the European countries have recommended a high moisture-content of 18 per cent is that they use less salt in their butter. An 18 per cent moisture, according to their methods of salting, would be about the same as 16 per cent in this country.

The authors are very much in favor of a definite standard for butter, the minimum fat-content being 80 per cent and the moisture-content 16 per cent. Some tolerance or allowance seems necessary, as butter may vary in moisture, especially from one end of the churn to the other, as much as 1 or $1\frac{1}{2}$ per cent.

Factors that Aid in Moisture Control.—The two principal factors that aid in the control of moisture in butter are the per cent of fat in the cream and the temperature at which the cream is churned. Where the fat runs uniform and the cream contains a high per cent of fat, the moisture can be controlled quite accurately by observing the size of the granule and controlling the temperature of churning.

Bulletin No. 101 of the Iowa Experiment Station, page 167, gives the results of some churnings made by the senior author in a demonstration to short-course students during the month of January, 1908. This butter was worked in a Victory churn. The cream for these particular churnings was separated from whole milk by the Randall Creamery Company, Randall, Iowa, and shipped to the Iowa Experiment Station. Upon arrival the cream tested from 42 to 45 per cent. After reducing with a starter, holding the cream over night and churning the next morning, the results given in the accompanying table were obtained.

Butter proper contains, besides the water, fat, protein and curd, a small amount of milk-sugar, .35 per cent, and ash from .14 to .16 per cent. A butter-maker, to be successful, must study his conditions from day to day and from week to week; otherwise, during a rainy season when the grass becomes slushy, the moisture-content is likely to vary or exceed the limit, even

Date	Churn	Lbs. of Cream	Per Cent Test	Butter-Fat	Churn Temperature	Butter-milk Temp.	Temperature of Spray	Rev. for Salt	Amt. of Butter	Per Cent Over run	Per Cent Water
Dec. 31	Vic.	1283	32.5	412	58	59	54	14	518	22	15.8
Jan. 3	Vic.	1343	36.5	490	58	59	53	13	600	22.5	15.9
Jan. 6	Vic.	1435	34.5	495	57	58	54	13	609	23	15.3
Jan. 7	Vic.	1204	33.5	403	57	58	54	13	499	23	15.9
Jan. 10	Vic.	910	33	300	57	58	58	18	375	24	15.7

though the same regulations have been observed as at other times. Makers have been heard to say that they could control the moisture-content of butter to within two or three hundredths of the limit. Serious doubts may be entertained as to the correctness of such a statement.

Not very long ago a butter-maker called at the office of the American Association of Creamery Butter Manufacturers and proclaimed that he was churning in such a way that his moisture-content would not vary more than two or three hundredths of a per cent from day to day. He was asked to send a sample of his butter to the Association laboratory, and it was found to have a moisture-content of nearly 17 per cent. The moisture in the samples he sent in varied 2 per cent, or ranged from 15 to 17 per cent.

Different methods are used for controlling moisture. Some make a moisture test when the working of the butter is about half finished. If it is found that the butter runs low in moisture they add to the churn the amount of water they wish to incorporate and continue working until the butter takes up the water added to it in the churn. On the contrary, if they find the moisture is too high they fasten the churn door so that moisture will escape and continue to work the butter until it contains the right per cent of moisture.

Other companies that manufacture enormous quantities of butter never work butter in water. They endeavor to control the moisture entirely through their methods of churning. They are not, however, trying to crowd the limit in moisture.

With thick cream, or cream containing a low per cent of

fat, it is a more difficult problem approximately to control the composition of butter. Churning cream at a high temperature will invariably result in a high moisture-content and will also result in an extreme loss of fat in the buttermilk.

In churning cream of medium-high fat-content, it is advisable to fill the churn only about half full, to churn at such a low temperature that the butter will gather in about forty-five to fifty minutes, and to churn the butter to granules about as large as peas. A small variation in the components of butter affects the quality very little, provided the butter has been properly made and the components properly incorporated. In the same creamery the composition of butter varies according to the season of the year, from day to day or even from churning to churning. According to the present methods of manufacturing, water and salt are the components most likely to vary. Casein will vary very little if the butter is efficiently washed and churned in a condition in which it will gather firm. Normally, casein is estimated at 1 per cent, occasionally it has been found to run as high as 4 per cent. It rarely exceeds 2 per cent, and seldom falls as low as $\frac{5}{10}$ of 1 per cent. A high curd-content will show itself in the butter in the form of milky brine or in the form of white specks. If there is less than 2 per cent present, the brine will not be affected.

One of our large creameries had an average casein content of .65 for a year. This was due to their method of washing their butter a number of times. An excessive amount of casein in butter is supposed to affect its keeping qualities.

Curd and milk-sugar are incorporated from the milk into the butter during the churning. In the manufacture of butter for storage, these substances should be excluded from the butter as thoroughly as possible. Milk-sugar and albuminoids constitute the chief foods for bacterial growth. As deterioration of butter has been demonstrated to be due chiefly to the action of micro-organisms it becomes essential to restrain their growth as much as possible by excluding the food necessary for their growth.

The average salt-content of butter is about $2\frac{1}{2}$ per cent;

it may vary from 1 to 4 per cent. The amount of salt properly dissolved in butter depends upon the amount of water present. The first important step in controlling the salt-content is to have a reasonable control of the water-content of the butter. If there is 16 per cent of water present in butter it is desirable to incorporate as much salt as the water will dissolve within the time usually allotted for that purpose. This amount of salt suits most of the American butter markets.

The authors have analyzed commercial butter containing as high as 8 per cent salt, the major portion of this being present in an undissolved condition. Such butter is called gritty and is objected to by the consumer. Salt acts as a preservative to some extent and adds flavor to butter provided it is in good condition. It has been said that the addition of salt has some effect upon the body of butter.

Richmond asserts that salted butter loses more water on standing than unsalted butter. Undoubtedly this is due to the fact that the salt added to butter has an affinity for water and the drops of water in salted butter are much larger; consequently, unless the butter is thoroughly worked so as to break up the drops of water into smaller drops, this will have a tendency to cause what is known to the trade as leaky butter. It is much more difficult to expel moisture from unsalted butter; consequently, a great deal of unsalted butter has been seized by the Internal Revenue officials due to the fact that it exceeded the prescribed moisture limit set by the Internal Revenue Department.

Unsalted butter, if exposed to medium-high temperatures, deteriorates quite rapidly, and frequently has a pronounced cheesy flavor. If it is kept at an extremely low temperature it keeps well in storage. Creameries have been known to put up their butter in an unsalted condition in the summer and put it down to zero or below; in the winter they took it out, salted it, and worked it up in prints as fresh butter for their winter trade.

Excessive moisture in butter causes it to become dull or lusterless in color. Butter that has a very dry appearance and is

dull in color is invariably high in moisture. Overworking butter or working it to a condition where an additional amount of air is incorporated not only affects the color but gives the butter, when placed in storage, a tendency to deteriorate quite rapidly and become fishy.

The temperature of the wash-water has a bearing upon the quality of butter. Water that is too high in temperature has a tendency to soften the granules and thus cause them to absorb an excessive amount of moisture. When the temperature of cream is too high for churning, an excessive amount of buttermilk is incorporated in the butter and the latter will not keep well either in storage or out of storage. The more butter is worked in the presence of water the more water it will take up.

Making butter from pasteurized cream has a tendency to cause a greater loss of fat in the buttermilk.

CHAPTER XXI

DEFECTS FOUND IN BUTTER

SOME OF THE CAUSES AND THEIR PREVENTION

IN the scoring of butter, 45 points are allowed for flavor, 25 for body, 15 for color, 10 for salt and 5 for package. This is the score that is generally recognized in this country. Some expert judges have used the score of 50 for flavor, in which case 5 are taken off for body, allowing 20 instead of 25. We can, therefore, see that flavor is the most important factor in determining the quality of butter. The other defects found in butter are mechanical defects caused by the process of manufacturing. Undesirable flavors affect the selling price of butter more than anything else.

Flat or Insipid Flavor.—Butter that lacks flavor is sometimes termed by judges insipid, or flat. Various terms are used in describing the flavor of butter. For good butter, such terms are used as rich, creamy, aromatic. Butter may be rich in flavor without having a pronounced aroma. This kind of butter has a pleasant palate flavor. A flat or insipid taste may be due to several causes, such as excessive washing and making butter from unripened cream. If cream is pasteurized and a large per cent of good starter is used, the flat flavor, above described, will be overcome.

Butter made from cream of which the flavor is not clean will score much higher if it is unsalted. For this reason, many creameries manufacture their second-grade cream into butter without the use of salt and make what is known to the trade as "sweet butter." The theory was advanced some years ago, by writers on butter, that heavy salting covered up many defects. Various investigations have demonstrated that this is not true.

Heavy salting has a tendency to bring out the latent flavors. Butter made during the winter months is usually deficient in flavor, especially where the cream has not been ripened. Hence, flat-flavored butter is more prevalent in winter than during the summer months.

Stable Flavors.—Stale and stable flavors are also quite prevalent during the winter months. Many of the organisms that gain access to milk and cream during the winter months come from the stables and are putrefactive organisms that decompose the casein, such as *Proteus vulgaris*, *B. subtilis* and *B. fluorescens*. These organisms are usually found in milk produced in stables and gain entrance from many sources, such as manure, feed, water, dirty utensils and the air; it is therefore practically impossible to exclude them. There are also a number of other organisms that decompose the casein. Keeping milk too long in a poorly ventilated cow-stable has a tendency to cause it to take up flavors by absorption. Where cows are milked in warm basement stables, poorly ventilated, undesirable fermentation is apt to predominate in souring the cream without the use of a starter. Two of the principal causes, however, of poor quality in cream are failure thoroughly to wash and scald all dairy utensils that come in contact with milk or cream, especially separators, and failure quickly to cool the cream to a low temperature to check fermentation.

Flavors Acquired by Absorption.—The most common of these are house flavors, cellar flavors and vegetable flavors. These flavors are all taken up by absorption by the cream. While pasteurization will not remove all these flavors, it has the effect of removing some of them. Pasteurization to a high temperature, 180° to 185° F. under the flash method, or 170° F. under the holding method, and the use of a good starter, will improve the flavor of butter made from such cream. House, cellar and food flavors are at times so pronounced in butter that a butter judge can give a very accurate account of where the cream was kept by merely examining the butter.

Cheesy Flavor.—Cheesy flavor is a defect that is sometimes found in butter of low-scoring quality that has been kept for a

long time at high temperatures. When butter is deteriorating very rapidly in quality it usually reaches the stage where it has a pronounced cheesy flavor, which later on changes to what might be described as a turpentine flavor. Butter of this character will usually sell in the markets as "Seconds." Cheesy flavor is said to be due to decomposition of the curdy matter in butter.

Sour Flavor.—Sour flavor is sometimes caused by over-ripening the cream at the creamery. The authors have seen good cream from whole milk overripened to such an extent that it produced sour-flavored butter. The churning of cream with high acidity, without reducing this acidity, will produce sour butter. Butter judges sometimes describe a sour, disagreeable flavor as a dish-rag flavor, because the odor accompanying it is very much like that given off by an unwashed dish cloth. The use of unclean cloths for cleansing dairy utensils usually means the transmission of undesirable flavors to milk and cream. For washing utensils a brush is much preferable to a cloth.

Some creameries that are producing the best butter from shipped cream have a set rule that all cream cans must be thoroughly cleansed and sterilized before being returned to patrons.

Harding and Ayers both report that they were able to produce good milk in stables where manure was plentiful, and cobwebs were hanging from the ceiling, by sterilizing all dairy utensils that came in contact with the milk or cream.

Eckles, when connected with the Iowa Experiment Station, isolated *Bacillus coli aerogenes*, added it to pasteurized skim-milk and made a starter, and added the same to sweet cream for the purpose of ripening or souring it to determine the injurious effect it would have upon the flavor of butter. The quality of the butter produced was not seriously affected by this starter. One of the authors had the privilege of scoring this butter, and, in his judgment, it was good commercial butter, though not as pronounced in flavor as butter made from cream ripened by a culture starter.

Faulty Factory Conditions.—Bad flavors found in milk, cream and butter are sometimes due to conditions prevailing in the

factories, such as unsanitary pumps and leaky cream vats of coils. Unsanitary pumps have been the means of transmitting many undesirable flavors to both milk and cream.

Ayers states that he has investigated the causes of undesirable flavors in milk at milk plants, and has found the trouble to be due in some cases to unsanitary pumps. An instance of this kind came up in one of the best creameries in Iowa, a whole-milk plant that had been noted for the excellent quality of the butter it was producing. A cut of several cents a pound in the price of the butter had been made, due to a very disagreeable flavor that it had shown. The maker, who was above the average in intelligence, was unable to locate the cause of the peculiar flavor that was developing in his cream and butter. He asked the State Dairy Commissioner to send one of his best men to help them locate their trouble. The state inspector examined the creamery and found everything in apparently a good condition. He weighed the milk himself, and found the quality of the milk received was exceptionally good. As soon as the pump was started and the milk was pumped up to the heating tank and from there passed into the separator, the first cream passing from the separator showed the peculiar flavor that was found in the butter. From this it was concluded that the trouble was in the pump. The pump was taken apart, heated in the furnace for some time and thoroughly cleansed, then put together again. When the pump and separator were started again, the cream was fine. The maker's trouble was that he had not been in the habit of taking the pump apart for cleaning but had merely pumped water through it and steamed it. The hot steam evidently condensed, covering up undesirable organisms and protecting them from the heat of the steam. From this will be seen the importance of sanitary pipes and the use of a pump that can be thoroughly cleansed every time it is used, for either cream or milk.

Leaky vats and coils in creameries are sometimes the cause of bad flavors. A leaky vat will produce in cream a pungent, disagreeable flavor that is somewhat different from the flavor produced by almost anything else, and this will be transmitted

to the butter. One of the authors, when scoring educational butter, stated in writing to one of the exhibitors that the butter had a peculiar flavor that was undoubtedly caused by one of his cream vats leaking. Upon examination he found this to be the case.

Feed Flavors.—Some feeds have a pronounced effect upon the flavor of cream and butter; some of these are desirable and others undesirable. The flavor of turnip tops or turnips affects the sale of butter; but its effect can be largely overcome if these are fed after milking. Where cows have access to leeks, wild onions or garlic, very undesirable flavors will be produced in milk, cream and butter. Garlic and wild onions produce such a disagreeable, pungent flavor in butter that some creameries have refused to buy cream so flavored, while other creameries make a difference of 10 cents a pound in the price of the milk-fat.

Ayers and Johnson, in *Farmer's Bulletin No. 610*, give the results of their investigation on this subject.

For the Removal of Garlic or Onion Flavors.—It is a well-known fact that heating milk or cream to a high temperature will eliminate, in whole or in part, flavors of a volatile nature. If we combine with this the aeration of cream, through forcing or blowing air into it under pressure, this will further aid in the removal of such flavors.

In *Farmer's Bulletin 608* of the U. S. Department of Agriculture is given an outline of an experiment for the removal of onion or garlic flavor. In this experiment a vertical, cylinder-shaped, jacketed tank, with an agitator in it, was used for holding and heating the milk or cream, and above this was placed a smaller tank with a perforated bottom. The milk or cream was heated, the temperature being maintained at 145° F. or above. Air was then blown into the milk or cream through a pipe extending almost to the bottom of the tank; and at the same time the milk or cream was constantly pumped into the upper tank with the perforated bottom, from which it ran back, in fine streams, which reduced the foam on the top of the milk or cream in the larger tank.

It was found in this experiment that the higher the tem-

perature to which the milk or cream was heated the more efficient was the process. While it is impractical to heat milk, for domestic use, above 145° F., cream for butter-making can be heated to a much higher temperature. Milk or cream with a "strong" onion flavor was used. As to results, the onion flavor was removed from milk held at a temperature of 145° F. in from thirty to sixty minutes; while the flavor was wholly removed from cream, held at a temperature of 160° F. in forty minutes.

A considerable amount of investigational work has been done by the Extension Department of the Purdue Station, Indiana, on the eradication of wild garlic. We quote from what they have to say, as follows:

"To Eradicate Wild Garlic on a Large Scale.—Break the infested land late in the fall, plowing to such a depth as to turn up as many of the garlic bulbs as possible. Leave in this condition through the winter. Replow the field very early in the spring—not later than the tenth of April, if possible—disk and harrow at least a couple of times and plant to some summer crop such as corn, soy beans, cow-peas, potatoes, sorghum or millet. No garlic plants or very few will appear during the summer, but they will start their growth again in the fall. Remove the crop in time to allow another breaking late in the fall. Repeat as outlined for the first year, that is, break the field in the fall and again early in the spring and plant to summer crop. This process continued every season for three to five years will clean out the garlic entirely.

"To Eradicate Wild Garlic on a Small Scale.—Spray the plants about the middle of April with *orchard heating oil*. The oil destroys the plants entirely. More garlic may come up, however, the following fall or spring from the bulbs which had not germinated in the previous season. These must be sprayed again. The treatment may have to be repeated, in some cases, even in the third year."

The surest remedy for overcoming these defects in milk and cream is to keep the cows in pastures where the said obnoxious plants do not grow. Nitrate of potash, common saltpeter, has been used quite extensively in cheese sections of the country in

the late fall months, when turnip tops or turnips were fed, for the purpose of eliminating or removing odors from milk produced by cows having access to turnip tops or turnips.

For butter-making, the German government permits the addition of nitrate of potash to milk or cream for the purpose of removing flavors produced by the cows eating beets or beet tops. Onions and garlic predominate in the early spring and soon disappear. As soon as the grass advances to such an extent that it supplies the wants of the cows, they prefer it to weeds of any kind.

Advance in Lactation, Winter Feeds and Stable Conditions.

It is thought by many that the advanced period of lactation has a pronounced detrimental effect on the flavor of butter. Experiments conducted at the Iowa Experiment Station in 1896 (Bulletin 33, pages 606-609), by McKay and Eckles, do not substantiate this theory. In the various tests made the milk from the Experiment Station herd was used. The milk of fifteen cows, which averaged an advance of 239 days in their lactation period, was classed as stripper milk; while the milk of seventeen cows, which averaged an advance of 107 days in their lactation period, was classed as milk from fresh cows. During this experiment the cows were on good blue grass and were being fed, in addition, one-quarter of a pound of cottonseed meal at the beginning of the period. The cottonseed meal was gradually increased, until at the end of the experiment they received 1 pound each per day. The milking was done under personal supervision so that no error might be made through mixing the milk from the two lots. After being milked and strained into cans the milk was taken directly to the creamery. When the evening's milk was taken to the creamery it was aerated and put in an ice-box which was filled nearly to the top of the cans with ice and water. This kept the milk in good condition until the next morning, when the evening's milk and the morning's milk were mixed together and separated.

The milk from the fresh cows was separated and cared for in the same manner as that from the strippers. In order to make a closer connection between flavors a starter was prepared from the mixed milk of two stripper cows, the periods of lactation of which

were 339 and 356 days. The skim-milk from the stripper milk was permitted to sour and was then used as a starter for souring or ripening the cream separated from the stripper milk. The fresh cow's milk used for a starter was produced by a cow that had been thirty days in lactation. The skim-milk was permitted to sour in the same way as that from the milk of stripper cows.

Various tests were made of the butter made from the different milks. This butter was scored by W. S. Moore, who was then official scorer for the Elgin Board of Trade, and knew nothing of the nature of the experiment. The tubs of butter were all scored by number, and received practically the same score. The two highest-scoring lots of butter scored 95; one of these lots was made from the stripper milk and the other from fresh cows' milk.

From this and similar experiments reported in Bulletin No. 32, Iowa Experiment Station, it would seem that the period of lactation has little or no effect upon the flavor of butter, that is, when the milk is separated by centrifugal force, or by the little hand separator. Under the gravity system there may be some difference, as many dairymen claim there is. A possible explanation is that the fat-globules, as is well known, are smaller in the milk of cows well advanced in lactation, and when cream from such milk is raised by the gravity process more time is required for the cream to rise than when the milk is from fresh cows whose milk contains fat-globules of much greater size.

A bitter flavor is frequently found in milk or cream that is kept for a long time at a low temperature. There seems to be present in almost all milk an organism that is able to produce a bitter flavor in milk or cream at low temperatures, which are unfavorable to the development of the lactic acid organisms. Hence, the defects attributed to the period of lactation of the cow may be due to the method of separating the cream.

It is the aim of almost all farmers to have their cows come in fresh in the spring. Therefore, during the early winter months most of the cows are well advanced in their period of lactation. At this time they are milked in the stables and fed on dry feed,

hence, the opportunity for the milk to become inoculated with undesirable organisms is very great. Such conditions are apt to create in the minds of some the wrong impression that the defects found under winter conditions are caused by the advanced stage of lactation.

Most butter manufactured in the winter has what butter judges and dealers term winter flavors. Where the milk is received sweet at the creameries and the cream is separated and pasteurized and a good starter is used, winter conditions can be overcome. The importance of pasteurization and the use of a good starter during the winter months cannot be emphasized too strongly.

A quotation from Bulletin 101, Iowa Experiment Station, page 167, will help to show the improvement that can be made in the flavor of butter under right methods. "During the special winter course, beginning the latter part of December, 1907, and continuing until January, 1908, the Dairy Department of the Iowa Experiment Station arranged with the Randall Creamery Company, Randall, Iowa, to purchase their cream to be used during the special short-course." In this case it is presumed that the cows were well advanced in the period of lactation, they were certainly subject to normal winter conditions. The Randall Creamery, which is a whole-milk creamery, received the milk and separated it. The sweet cream, in this case, was shipped to the Iowa Experiment Station where it was pasteurized, ripened by the use of a good starter and churned the next morning. The cream skimmed at the plant contained 42 to 45 per cent butter-fat, after the starter was added it contained 32 to 35 per cent fat. As the Randall Creamery Company were shipping their butter to Gude Bros., New York, they made a request that the butter produced from their cream at the Iowa Experiment Station be shipped to the same place. This was done, with instructions to the Gude Bros. and P. H. Keiffer, the well-known butter judge of that firm, to score each shipment critically and report on the same. At the close of the shipments, Mr. Keiffer made the following report:

"I am very much pleased to be able to report that the butter

which you shipped us this winter, made from cream obtained from the Randall Creamery during the 'Short Course,' was very fancy, and scored from 93 to 96 points. Very little butter arrived at that time as fine in flavor as this. Our best trade was well pleased with your butter. I wish that more of the creameries were making this high quality butter at the time of year when it is so difficult to make it. The workmanship was perfect in every respect, so far as I could see, and the flavor was fine."

If the above-mentioned cream had been permitted to sour naturally the chances are that the flavor would have been very inferior instead of fine. The authors have found the best temperature for ripening cream during the winter months to be 70° to 74° F.

From the above it seems that the flavor of the butter is not injured by the advance in the lactation period of the cow but rather by undesirable fermentations that develop in the cream if permitted to sour naturally, especially during the winter months.

Tallowy Flavor.—Tallowy flavor is sometimes found in butter, usually in butter that has been kept under rather unfavorable conditions. Butter of this character has a taste somewhat similar to that of old tallow. This peculiar flavor is more apt to develop in print than in tub butter. It occurs, however, in tub butter when it has been bored a number of times, thus bringing the air into contact with the inner parts of it. It is found sometimes in print butter which has been exposed to the air and light, and the color may be seriously affected, even to the extent of bleaching the surface butter white.

The cause of tallowy flavor in butter is oxidation. U. S. Bulletin 84 shows the effect of air on the quality of butter. A number of cans of butter were put up by Gray, and hermetically sealed. Some of these cans were packed full, some about three-quarters full, some about half full, and the butter in one lot was put in loosely where the air came into contact with it. Thus, the amount of butter in these cans was so varied that different-sized air spaces were left. The solidly packed butter in every instance kept the best in storage. The butter that was loosely packed deteriorated very rapidly, showing a tallowy or fishy

flavor. Mr. Gray, in commenting upon this butter, makes the following statement:

“Comparing the average scores of butter in full cans and in partially full cans it will be noted that there were differences of 1 to 5 points in favor of the full cans. It does not seem necessary to take up these differences in detail. This deterioration was without doubt due to air in the partially full cans. Since in packing butter in cans there is no necessity for having the cans only partially full, neither is this economical, the writer does not hesitate to state that where the sealing is done at atmospheric pressure the cans should be entirely filled, leaving as little air space as possible. This principle may be applied to packing butter in other packages. The butter should be packed solidly, leaving as few air spaces as possible. Air having a deteriorating effect on the keeping of storage butter, it would be expected that butter stored in small open packages, as pound prints, would not keep so well as butter in large packages. This is a belief that has already been accepted by many.”

High-scoring butter that has been bored a number of times at conventions or butter contests, has a tendency to deteriorate in quality and show a slight tallowy flavor. One of the authors has had the opportunity of judging butter at various times in almost every dairy state in this country, and in some of the foreign countries, thus being afforded a wide range of opportunity for examining prize-winning tubs or packages of butter.

The impression prevails with some that high-scoring butter lacks keeping quality. The only way whereby this statement could be verified would be to place a tub of the same butter in storage and leave it there at storage temperature for six or seven months. When we take into consideration that some of the best butter at a contest is bored a great many times and thus exposed to the air, it would be difficult to determine whether the defect in the butter were caused by high ripening or by excessive boring. An instance of excessive boring was brought to the attention of the authors in a national contest that was held at Milwaukee some years ago, where both authors were present acting in the capacity of experts, one pointing out the defects in

the butter and the other writing each exhibitor giving suggestions as to the possible cause of the defects existing. Three well-known judges worked in this contest, one from Philadelphia, one from Boston and the third from Chicago. There were between seven and eight hundred entries of butter exhibited. On the first day's scoring the judges set aside a tub of extra fine butter to be rescored. The butter had a fine aroma and a clean palate flavor. It had what the authors would describe as a creamy, pleasant flavor. The quality of this butter was such that it was used as a standard by which to gage the score of the other tubs of butter in the final scoring. It is the custom in a large contest of this kind for the judges to set aside all butter that will score as high as 95 points out of a possible 100. This butter is placed in what the judges term the "shake-down." After all the other butter is scored, the judges after resting for some time go to work on the "shake-down" with a view to placing the highest scores. This particular tub of butter was used as a standard by which to fix the other grades. The result was that this butter was bored possibly twenty-five or thirty times. When the judges in the final score placed this tub fourth, on the ground that it was showing at that time a slight tallowy flavor, their decision caused some dissension and dissatisfaction. It certainly was not fair to this exhibitor to have his butter bored so many times, and the authors believe that the repeated boring of a tub of butter in a contest with the resulting contact with the air is not a fair test of its keeping qualities.

The bleaching of tallowy butter does not usually occur until it has been held for some time. Tallowy flavor is not very frequently found in butter that has been placed in cold storage.

Overworking butter to the extent that it will become greasy in appearance and taste has a tendency to cause tallowy flavor. By overworking butter, extra air is incorporated. Butter that is churned in such condition that the granules will gather firm will stand an extra amount of working without any effect upon the body. If cream is churned immediately after reaching churning temperature, before the fat has sufficient time to be thoroughly chilled, the fat has a tendency to gather in a soft condi-

tion, and if such butter is worked to the extent of avoiding mot- tles and thoroughly incorporating the salt, there is danger of the body being seriously affected and the butter having a greasy or lardy taste.

Butter which has been well made and kept away from the light when placed in storage will seldom, if ever, show a tallowy flavor.

Metallic Flavors.—A heavy loss is sustained by the butter industry every year through metallic and fishy flavors. There does not seem to be a clear understanding between some butter judges as to the distinction between these two classes of flavors. Metallic flavor and fishy flavor are two entirely different things.

Metallic flavor shows in the butter as soon as it is churned and is invariably found in butter made from extremely sour cream, while fishy flavor develops in butter on standing. What actually causes metallic flavor is not thoroughly understood, and various causes have been assigned by different people. Metallic butter has a pungent flavor, characteristic of the taste of metallic salts. Many people are of the opinion that cream acquires a metallic flavor by being shipped in rusty cans or coming in contact with vats or coils from which a portion of the tin has been removed.

Certain creameries have reported that in some cases the first churning from a vat of cream is free from metallic flavor, while this flavor is present in the second churning from the same vat. This would seem to indicate that the flavor is due to the develop- ment of some undesirable fermentation, or to bacterial action.

The peculiar feature about metallic flavor is that it is a sea- sonal condition; it comes and disappears. Heat seems to intensify it or make it more pronounced. The authors have known creameries that were troubled with metallic flavor which dis- appeared when they discontinued pasteurization. Cream coming in contact with vats, coils or cans from which the tin has been removed may develop a metallic flavor as a result of this. How- ever, when we take into consideration that metallic flavor is a seasonal condition, the theory of rusty cans or the partial removal of tin from vats or coils does not offer a complete explan- ation, as creamerymen use the same cans and vats during the

entire season. If the trouble were wholly due to the removal of the tin from the vats or coils, it would continue throughout the year.

Guthrie reports that he placed 157 samples of cream in sterile glass bottles and inoculated with an individual species of bacteria, and that 52 showed metallic flavor. Naturally the creamery-men will be more interested in what will prevent metallic flavor than what causes it.

One of the largest creamery companies in this country which, like others, was formerly troubled with metallic flavor claims it has not had any difficulty for several years, due to the method observed in manufacturing. The president of the company stated to one of the authors that they had bid good-bye to metallic flavor several years ago. The method they pursue is neutralization to a low degree of acidity and thorough cleanliness. If metallic flavor makes its appearance they reduce the acidity to .27 per cent before pasteurization and then again, by adding limewater, reduce the acidity to .04 or .05 per cent, and ripen with a pure culture. In addition to this, they thoroughly cleanse all pipes and faucets, and everything else with which the cream comes in contact. They maintain that this method of procedure has entirely eliminated metallic flavor from the butter they manufacture.

Fishy Flavor.—Fishy flavor causes greater losses in butter than any other one defect. In recent years a great many so-called discoveries have been made by different scientists as to the actual cause of fishy flavor. These discoveries have been investigated and disputed by other scientists, and the result is that fishy flavor is still with us. Butter made from high-acid cream will invariably go fishy if placed in cold storage for a long time, or for the natural storage period.

Prior to the introduction of partial neutralization of acidity in cream, butter made from hand-separator cream containing a high per cent of acid invariably turned fishy when kept in storage for any length of time. One of the leading dealers in Chicago stated that for two years he had bought butter made by some of the large creameries from sour cream the acidity of which had

not been reduced, and that in almost every case the butter was fishy when it came out of storage. He said that as a result of this he had made up his mind never to buy any butter from the so-called centralized creameries. The same firm now prefers to buy butter for storage purposes from large creameries where the acidity of the cream is reduced or controlled.

The following is a quotation from U. S. Bulletin by L. A. Rogers, S. C. Thompson and J. R. Keithley, page 8:

“In a tabulation of the examination of 259 samples of experimental butter from cream of known acidity, of 137 samples from cream having an acidity below 0.3 per cent, only 2, or 1.5 per cent, were marked ‘fishy,’ while of 122 samples having an acidity of 0.3 per cent or over, 60, or 49.2 per cent, were fishy. However, in all results which are dependent on the sense of taste, allowance should be made for difference of opinion and in the conception of the flavor associated with any particular designation.”

U. S. Department of Agriculture Bulletin 84, page 23, 1906, by C. E. Gray and G. L. McKay, entitled “The Keeping Qualities of Butter made under Different Conditions and Stored at Different Temperatures,” would indicate that acid has a pronounced effect in producing fishy flavor in butter unless the acidity of the cream has been reduced by partial neutralization. In this investigation part of the butter was made at Topeka, Kansas, from sour cream. Other lots were made at Monticello, Iowa, from sweet or whole-milk cream. The butter made from sweet cream did not turn fishy in storage, while practically all the butter made from sour cream had a pronounced fishy flavor after being kept in storage for some time.

Fishy flavor may be prevented with certainty by making butter from pasteurized sweet cream. Butter made from pasteurized sweet cream with a starter added, but without ripening, seldom if ever becomes fishy.

Of 25 different churnings of cream made at Strawberry Point, Iowa, July, 1907 (Bulletin 101, by McKay and Bower, page 164), 8 were made from unpasteurized cream and 17 from pasteurized cream. The cream was ripened in all cases with a pure culture

starter, average acidity developed .68 per cent. A tub of butter from each churning was stored in New York between six and seven months, and came out of storage without any trace of a fishy flavor. The butter was scored when entering storage and when coming out by P. H. Keiffer, the well-known butter judge. The average scores on flavor were, first scoring 38.17, second scoring 38.25. The butter was pronounced by the expert scorer as being some of the finest butter he had ever seen come out of storage. Two 56-pound boxes from each churning were shipped to London, Liverpool, and Manchester, England, where they were scored by experts and pronounced unusually fine. The average in England, on flavor, was 38.5. The Strawberry Point Creamery at that time received about 50,000 pounds of milk daily. The milk was all inspected before being taken into the creamery, and any milk that was sour or tainted was rejected. The milk was all separated by power separators and the cream skimmed so as to contain a high per cent of milk-fat. The high per cent of acid developed in this case apparently had no effect upon the keeping quality and did not produce a fishy flavor. It would, therefore, seem that the quality of the milk or cream used in the manufacture of butter is somewhat responsible for its going fishy.

The Danish butter, which has gained a world-wide reputation, is practically all made from whole milk delivered at the factories, the cream being ripened with a culture starter. While cream of high acid has a tendency to go fishy, fishiness cannot be attributed entirely to the development of acid in cream. At the present time probably 90 per cent of the butter produced in this country is produced from cream separated on the farms. The washing of the separators and other dairy utensils is entirely in the hands of the producer. It is only reasonable to suppose that some of the patrons of almost every creamery do not pursue sanitary methods in the care of their separators and other utensils that come in contact with the cream. Such cream is undoubtedly inoculated with undesirable organisms before it reaches the creamery, and if an attempt is made to ripen or develop much acid in it, other changes will also take place. To make butter

possessing good keeping qualities, under present conditions, it is necessary to neutralize when the cream is very sour, and develop a low degree of acidity. The Dairy Division has found that pasteurizing cream with a low degree of acidity and churning it sweet, or without the use of a starter, produces a butter that is entirely free from fishy flavor.

CHAPTER XXII

JUDGING AND GRADING BUTTER

BUTTER may be judged from a commercial and from an individual standpoint. Individual judgments of the same butter may vary considerably. It is important that the judge should become familiar with the quality of butter as required by our standard markets, and then judge the butter according to the demands of the mass of the consumers, rather than according to personal likes and dislikes. In order to become a good butter-judge, it is essential that the senses of taste and smell be acute. Even if one's taste and smell are keen and sensitive, considerable practice or experience is necessary. Almost any one can tell a good sample of butter from a very poor one, but when it comes to differentiating between two samples which are nearly alike in quality, skill and experience are required.

The chief requirement in scoring butter is to become thoroughly familiar with the ideal flavor of butter; then by repeated comparisons of different samples of butter with this ideal flavor, one will soon become efficient in grading the butter.

Standard for Judging.—In America the distinct qualities which are noticed in butter are designated according to the basis of points given below. It will be noticed that different values are given to the different characteristics, according to their relative importance. The score-card given below is used commercially, and is based upon 100 as the perfect score:

SCORE CARD			
No.	Perfect	Score	Remarks
Flavor.	45		
Body.	25		
Color.	15		
Salt.	10		
Style.	5		
Total.	100		
Date.		Scored by	

MANNER OF JUDGING

Body.—After the trierful of butter has been drawn out, the first thing to notice is the aroma, and the body or texture of the butter. The butter on the outside should be examined at once before it is affected by the temperature of the room. Notice its color, whether it is even or uneven, low or high. Determine by the appearance of the butter and the way it feels to the palate whether it is greasy, tallowy, spongy, or sticky. The amount and condition of brine should also be noted. These characteristics and their causes have been previously discussed. Stroke the plug of butter with a knife to observe the color closer. Squeeze it with the thumb to ascertain the character of the body. The aroma of the butter should also be noticed in connection with scoring the butter on body or texture, as it is more pronounced immediately after the trierful of butter has been drawn.

Flavor.—It is impossible to describe all the different flavors found in butter. There are perhaps as many distinct butter flavors as there are shades of color. However, there are a few flavors which stand out more prominently and are more commonly met with than any of the others. Good butter should possess a clean, mild, rich, creamy flavor, and should have a delicate, mild, pleasant aroma. Some butter-judges, especially foreign judges, allow a separate number of points for aroma of butter in the score-card. This has been suggested in the United States also, owing to the fact that butter may have little aroma and still have a good flavor.

Color.—The color should be bright and even. When a plug of butter is drawn with a trier and is held up to the light, it should not be cloudy and dense, but should be almost transparent and bright. The chief fault found with the color of butter is unevenness. It may be streaky or mottled, or it may be too high or too low. The shade of color will vary according to the different markets; in most of our markets a straw color is preferred. There has been a tendency recently to recommend a comparatively light shade of color in butter. A reddish color

should be guarded against, except when the market demands it. If too much color is added, butter will assume this hue, which is undesirable.

Salt.—The amount of salt likewise depends upon the market, and unless the salt-content is extremely high, or extremely low, butter should not be criticized on account of the amount of salt. The chief thing to consider in judging butter on its salt-content is the condition of the salt. Notice whether it has been thoroughly dissolved and evenly distributed.

Style.—The style is the appearance of the butter and package. Whatever the shape of the package, the chief thing to consider is whether it is clean and neatly finished.

CLASSIFICATION—GRADES AND SCORES

While the different butter markets differ more or less as to details, in their classification and grading of butter, they correspond closely when it comes to the large essentials. As the New York and Chicago markets are the two great butter markets of the United States, the following is quoted from the Rules of the New York and Chicago Mercantile Exchanges, respectively:

New York

1. Butter shall be classified as Creamery, Renovated, Ladles, Packing Stock and Grease Butter.

DEFINITIONS

2. **Creamery.**—Butter offered under this classification shall have been made in a creamery from cream separated at the creamery or gathered from farmers.

3. **Renovated.**—Butter offered under this classification shall be such as is made by melting butter, clarifying the fat therefrom and rechurning the same with fresh milk, cream or skim-milk, or other similar process.

4. **Ladles.**—Butter offered under this classification shall be such as is collected in rolls, lumps, or in whole packages and reworked by the dealer or shipper.

5. **Packing Stock.**—Butter offered under this classification shall be original farm-made butter in rolls, lumps or otherwise, without additional moisture or salt.

6. Grease butter shall comprise all classes of butter grading below thirds, or of packing stock grading below No. 3 as hereinafter specified free from adulteration.

GRADES

7. Creamery, renovated and ladles shall be graded as extras, firsts, seconds and thirds; and packing stock shall be graded as No. 1, No. 2 and No. 3.

DEFINITION OF GRADES

8. Grades of salted butter must conform to the following requirements:

Extras

9. Shall be a standard grade of average fancy quality in the season when offered under the various classifications. Ninety per cent shall conform to the following standard; the balance shall not grade below firsts:

Flavor.—Must be sweet, fresh and clean for the season when offered if creamery, or sweet, fresh and reasonably clean if renovated or ladles.

Body.—Must be firm and uniform.

Color.—Not higher than natural grass, nor lighter than light straw, but should not be streaked or mottled.

Salt.—Medium salted.

Package.—Sound, good, uniform and clean.

Firsts

10. Shall be a grade next below extras and must be good butter for the season when made and offered, under the various classifications. Ninety per cent shall conform to the following standard; the balance shall not grade below seconds.

Flavor.—Must be reasonably sweet, reasonably clean and fresh if creamery or renovated, and reasonably sweet if ladles.

Body.—Must be firm and fairly uniform.

Color.—Reasonably uniform, neither very high nor very light.

Salt.—May be reasonably high, light or medium.

Package.—Sound, good, uniform and clean.

Seconds

11. Shall be a grade next below Firsts.

Flavor.—Must be reasonably good.

Body.—If Creamery, must be solid boring. If Ladles or Renovated, must be 90 per cent solid boring.

Color.—Fairly uniform, but may be mottled.

Salt.—May be high, medium or light.

Package.—Good and uniform.

Thirds

12. Shall be a grade below Seconds and may consist of promiscuous lots.

Flavor.—May be off-flavored and strong on tops and sides.

Body.—Not required to draw a full trier.

Color.—May be irregular or mottled.

Salt.—High, light or irregular.

Package.—Any kind of package mentioned at time of sale.

13. (For grades higher than Extras, see paragraph No. 28).

No. 1 Packing Stock

14. Shall be sweet and sound, packed in large, new or good uniform second-hand barrels, having a wooden head in each end, or in new tubs, either to be parchment paper lined. Barrels and tubs to be packed full.

No. 2 Packing Stock

15. Shall be reasonably sweet and sound, and may be packed in promiscuous or different kinds of barrels, tubs or tierces, without being parchment paper lined, and may be packed in either two-headed or cloth-covered barrels.

No. 3 Packing Stock

16. Shall be a grade below No. 2, and may be off-flavored, or strong; may be packed in any kind or kinds of packages.

17. Charges for inspection of Packing Stock shall be the same as the rules call for on other grades.

18. *Mold*.—There shall be no grade for butter that shows mold.

Scoring

19. *Scoring*.—The standard official score shall be as follows and shall apply to Salted Creamery Butter only:

	Points
Flavor.....	45
Body.....	25
Color.....	15
Salt.....	10
Style.....	5
	100

20. Extra Creamery may score either 91, 92 or 93 points at the discretion of the Butter Committee, who shall determine the required score from time to time in such manner that it shall represent an average fancy quality in the season when offered. But butter scoring more than required for Extras shall be deliverable on a contract for Extras, and may be branded as such at the request of seller, or buyer. Any change in the Standard score required for Extras shall, after authorization by the Butter Committee, be announced by the caller at the opening of the next regular call and posted upon the bulletin board of the Exchange and be effective twenty-four hours later.

21. The minimum score of Firsts shall, at all times, be 4 points below the score required for Extras.

22. The minimum score of Seconds shall be 5 points below the minimum score required for Firsts.

23. The minimum score of Thirds shall be 7 points below the minimum score required for Seconds.

UNSALTED CREAMERY

Extras

24. Shall be a standard grade of average fancy quality in the season when offered under the various classifications. Ninety

per cent shall conform to the following standard; the balance shall not grade below Firsts.

Flavor.—Must be sweet, fresh and clean for the season when offered.

Body.—Must be firm and uniform.

Color.—May be very light straw, white, or natural grass, but must not be streaked or mottled. The seller must specify the color at time of sale.

Package.—New, uniform and clean.

Firsts

25. Shall be a grade next below Extras and must be good butter for the season when made and offered, under the various classifications. Ninety per cent shall conform to the following standard; the balance shall not grade below Seconds.

Flavor.—Must be reasonably sweet, reasonably clean and fresh.

Body.—Must be firm and fairly uniform.

Color.—May be very light straw, white, or natural grass, but must not be streaked or mottled. The seller must specify the color at time of sale.

Package.—Sound, good, uniform and clean.

Seconds

26. Shall be a grade next below Firsts.

Flavor.—Must be reasonably good.

Body.—Must be solid boring.

Color.—Fairly uniform, but may be mottled.

Package.—Good and uniform.

Thirds

27. Shall be a grade below Seconds and may consist of promiscuous lots.

Flavor.—May be off-flavored and strong on tops and sides.

Body.—Not required to draw a full trier.

Color.—May be irregular or mottled.

Package.—Any kind of package mentioned at time of sale.

<i>Scoring</i>		Points
Flavor.....	45	
Body.....	25	
Color.....	20	
Style.....	10	
	—	
		100

SALES UNDER THE CALL

28. Creamery butter salted of a score higher than required for Extras may be offered and bid for by score. The score of such butter may be considered its grade; or such higher scoring butter may be delivered on a contract for Extras. This grade of butter, above "Extras," is commonly designated by the trade as "Specials."

Chicago

1. Butter shall be classified as Creamery, Centralized Creamery, Held Butter, Renovated, Ladles, Packing Stock and Grease Butter.

DEFINITIONS

2. **Creamery.**—Butter offered under this classification must be made in a creamery, the cream having either been separated from the whole milk at the creamery or received by team or motor at the creamery direct from the farm.

3. **Centralized Creamery.**—Butter offered under this classification must be made in a creamery. The cream used in the manufacture of this butter may be gathered direct from the farmer or shipped in from individual shippers or cream stations.

4. **Held Butter.**—Butter offered under this classification shall be butter that has become cold storage butter by virtue of the laws of the United States or of the state in which such butter is sold.

5. **Renovated.** Butter offered under this classification shall be such as is made by melting the butter, clarifying the fat therefrom and rechurning the same with fresh milk, cream, skim-milk or other similar processes.

6. **Ladles.**—Butter offered under this classification shall be such as is collected in rolls, lumps or whole packages and reworked or re churned, resalted or recolored by the dealer or shipper.

7. **Packing Stock.**—Butter offered under this classification shall be original butter without additional moisture or salt from creamery or dairy (but may be from miscellaneous sources), which has been collected in any quantity and packed in tubs, barrels or other containers. It must be of a quality fit for human consumption as food and free from adulteration.

8. **Grease Butter.**—Butter offered under this classification shall consist of all grades of butter below thirds. If packing stock, below No. 3, and free from adulteration.

GRADES

9. Creamery and Held Creamery shall be graded Extras, Firsts, Seconds and Thirds. Centralized Creamery shall be graded Extras, Standards, Firsts, Seconds and Thirds. Renovated and Ladles as Firsts and Seconds. Packing Stock as No. 1, No. 2, and No. 3.

Scoring

10. The standard official score for salted butter shall be as follows:

	Points
Flavor.....	45
Body.....	25
Color.....	15
Salt.....	10
Style.....	5

11. The standard official score for unsalted creamery butter shall be as follows:

	Points
Flavor.....	45
Body.....	30
Color.....	15
Style.....	10

12. All grades of butter must conform to the following requirements:

Extras

13. Shall consist of the best grade of butter in the season when produced and must score 92 points or better.

Flavor must be sweet, fresh and clean when offered as fresh, and sweet and clean when offered as Held Creamery. Body must be firm and of good texture. Color may be either light straw color, medium or high, but must be uniform and neither streaked nor mottled. Salt may be defined as light, medium or high, but must not be gritty. Package, new, sound, good, uniform and clean.

Standards

14. Standards shall be a grade of centralized creamery of average fine quality in the season when offered, scoring 90 points and above. Flavor must be fresh and clean if fresh, and clean if held. Body must be firm and of good texture. Color may be either light straw color, medium or high, but must be uniform, neither streaked nor mottled. Salt may be defined as light medium or high, but must not be gritty. Package, new, sound, good, uniform and clean.

Firsts

15. Shall be a grade just below Extras, scoring from 88 to (but not including) 92 points, must be good butter for the season when made and offered under this classification.

Flavor must be reasonably clean and fresh if Creamery, Centralized Creamery or Renovated, and reasonably clean and reasonably sweet if Held. Body must be firm and of fairly good texture. Color reasonably uniform, neither very high nor very light. Salt may be light medium or high. Package, new, sound, good, uniform and clean. If Ladles, must be 90 per cent solid boring, color reasonably uniform, package sound and clean.

Seconds

16. Shall be a grade below Firsts. The minimum scoring of Creamery Seconds shall be 4 points below the minimum scoring required for Firsts or a range of from 84 to (but not including) 88.

Flavor must be fairly good. Body, if Creamery, Centralized

Creamery or Held, must be solid boring. If Renovated or Ladles, must be 90 per cent solid boring. Color, fairly uniform, but may be mottled. Salt may be light medium or high. Package, good and uniform.

Thirds

17. Shall be a grade below Seconds and may consist of promiscuous lots. The minimum scoring for Creamery Thirds shall be 5 points below the minimum scoring for Seconds, or a range from 79 to (but not including) 84 points.

Flavor may be off-flavored and strong on tops and sides, more or less rancid. Body not required to draw a full trier. Color may be irregular or mottled. Salt high, light or irregular. Package, any kind of package mentioned at delivery.

No. 1 Packing Stock

18. Shall be original butter, solid boring, sweet and sound, without additional moisture or salt, free from mold, normal in oil contents, packed in barrels or in tubs or boxes. Where in barrels, parchment-lined packages are preferred. When in either tubs, boxes or barrels, same should be packed full.

No. 2 Packing Stock

19. Shall be original butter, 85 per cent of it solid boring, the other 15 per cent fairly solid boring, reasonably sweet and sound for the grade offered; may be slightly deficient in oil contents, must be free from mold and may be packed in different kinds of barrels, tierces, pails or boxes with or without paper lining.

No. 3 Packing Stock

20. Shall be a grade of quality just below No. 2 Packing Stock, but above the classification of Grease Butter; may be packed in any or all kinds of packages.

EXPORT BUTTER

The observations of the authors have been that the reputation of the American butter on the English market is not all that is desirable. Some American butter is good enough to sell on an

equality with Danish butter, and in some instances it is palmed off as such. Much poor butter, however, has been allowed to go to the English market, and this has in some measure ruined the reputation of our butter.

Butter for export purposes should be of the very best, and made in such a way as to insure good keeping qualities.

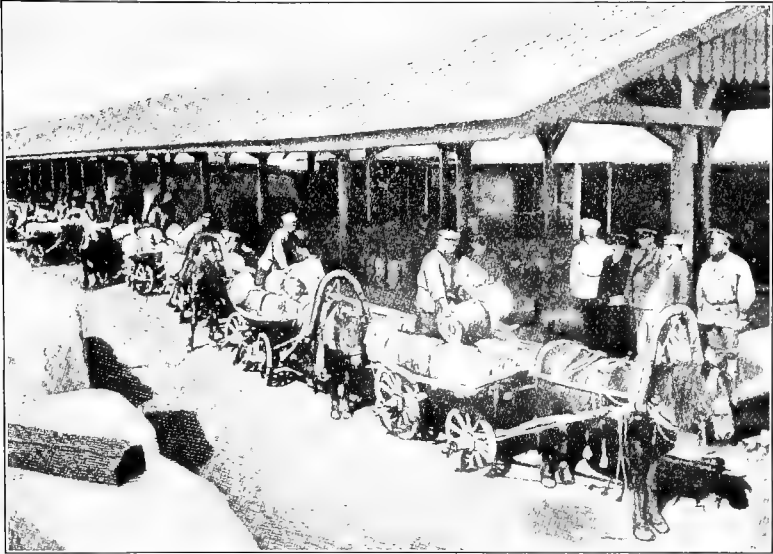

FIG. 128. Shipping Russian Butter from Siberia. (U. S. Govt. Bul.)

The standing of the different kinds of butter, as observed on the English market, were as follows:

- (1) Fresh French Rolls.
- (2) Danish Creamery.
- (3) Irish Creamery.
- (4) New Zealand.
- (5) Canadian, Australian, Argentine, United States, and Siberia.

For Storage Purposes

- (1) Danish.
- (2) New Zealand.
- (3) Siberia.

CHAPTER XXIII

COLD STORAGE AND BUTTER FOR STORAGE PURPOSES

History of Cold Storage. From early pioneer days the people had a knowledge of the fact that by placing perishable food products where the temperature was low they could keep them much better. Many of the early settlers discovered that there was a zone about 6 to 10 feet below the surface of the ground where the temperature was low. Hence they dug holes in the ground in which to keep various kinds of food products. Later, ice was used in various ways to lower the temperature. It was discovered that the lower the temperature, the better the food products would hold their flavor.

Refrigeration, as we have it to-day, is the result of a gradual evolution as to both process and efficiency. Cooling by means of ice was practiced by the ancients. We read that the monarch, Nero, had ice-houses built in Rome for the storing of natural ice. The cooling effect obtained through dissolving certain salts was recognized and made use of, as far back as 1762, by Fahrenheit, the inventor of the thermometer that bears his name. Salt-and-ice mixtures have been used for many years for refrigerating purposes, including the making of ice-cream, etc. In what is known as the "Cooper System" of refrigeration, ice and calcium chloride are used. Under this system the temperature of a well-constructed refrigerator can be maintained at 20° F., or below.

About 1845, Dr. Gorrie of New Orleans invented a cold-air refrigerating machine. Under his system the air is compressed but is not condensed to a liquid; hence it is not so practical as the more modern systems. At one time it was used extensively on ships on account of the absence of obnoxious gases. This system, while mechanical, differs from those here classed under that head.

Mechanical Refrigeration.—The underlying principle of mechanical refrigeration, that of the consumption of heat in the vaporization of a liquid, is not a new one. In the hot climates of many eastern countries, water for drinking purposes is kept in porous earthen vessels so that the wind may evaporate the moisture as it oozes through the pores of the vessel and so cool the water. In Arizona, and to some extent in Oklahoma, the farmers cool their cream by wrapping the cream can with a suitable cloth which acts as a wick to carry up moisture to be evaporated and, in so doing, absorbs heat from the cream in the can or, in other words, cools the cream.

A more refined and very much more effective application of this principle of cooling, through the vaporization of a liquid, is made under the modern system of mechanical refrigeration. Under the Compression system, which is explained in the chapter entitled, "Cooling Facilities for Creameries" the two substances most commonly used are anhydrous ammonia and carbonic acid gas. Professor Carl Linde of Munich invented the first ammonia compression machine in 1873. The carbonic acid machine, also compression, and copied after Linde's designs, appeared in 1880. In large creameries and central cold storage houses in this country, ammonia plants are much more common than carbonic acid plants, although on ships the latter are probably in more general use. In another system of mechanical refrigeration, what is known as the Absorption process is used. Under this system two substances are used, one of which remains a liquid and absorbs the other at ordinary temperatures. One combination is that of sulphuric acid and water, and another, water and ammonia.

Benefits of Cold Storage.—Mechanical refrigeration was first introduced into the United States about 1888. Its general effect, however, upon the storing of food and upon the market was not appreciably felt until about 1902. Cold storage is of great benefit to the public as a whole. As to the consuming public, it enables them to get perishable food products held over in many cases from the time of high production to the time of scarcity, thus establishing a greater uniformity of price throughout the

year. The producer of perishable products is also benefited from the fact that he gets higher prices during the time that he has his largest supply, which he would not be able to get if such products could not be carried over.

Prior to the general use of mechanical refrigeration for cold storage purposes, various food products sold at very low prices at the time of high production. This was particularly true of butter.

A. R. Loomis, of Ft. Dodge, Iowa, told one of the authors that at this early period he was able to buy several carloads of creamery butter, whole-milk goods, at 11 cents a pound. Certain seasons of the year are now designated as cold-storage seasons.

The season which is recognized as that for making butter for storage purposes is the period extending from the latter part of May to the first of July. This is regarded as the storage season, although some butter is stored at other times of the year as well. Practically all butter, however, is stored during the storage season, for two reasons: first, there is more butter made at this period than at any other time of the year; second, the grass is at its best, and the conditions are more favorable for making good butter than at any other time. During this period cows are usually milked outside and there is less chance for contamination. Hence, the best butter of the year is supposed to be made at this time.

Cold storage brings into the market many dealers in butter. They are willing to pay good prices in the summer, taking chances on making a reasonable profit during the fall and winter months, but in this they are sometimes disappointed. In various states laws have been enacted to regulate cold storage and prevent the possibility of any individual or combination of individuals cornering the food products for the purpose of forcing prices beyond what will net a reasonable profit.

A general agitation was started throughout the country by women's clubs and other organizations when food prices were extremely high. The impression prevailed among many that cold storage was responsible for hoarding or cornering of food products, but investigations by the Federal Government showed that hoarding was not the cause of high prices. Nevertheless,

the agitation became so pronounced that both the Republican Party and Democratic Party had planks in their platforms asking that laws be passed by Congress to regulate cold storage and also demanding a limitation of the length of time that food products should be held in storage, with requests for branding the same as storage products.

Cold storage has undoubtedly been of greater benefit to the farmer than to anyone else, as the fruits he produces as well as his poultry, meats and dairy products go into storage. If it were not for the fact that these products can be carried over from the time when there is an abundant supply to the time of scarcity, very low prices would be paid for them. According to the design of Nature, milk, cream and almost all other products can be produced more cheaply in the summer when grass is abundant, than in the winter months. This is an economic problem with the producer. There is no extra labor involved in feeding cattle during the period when they are on pasture.

Cost of Storage.—The average length of time that butter is kept in storage is approximately five or six months. Very little of the butter that is held in cold storage belongs to the owner of the cold-storage plant; it is held by many people distributed over a wide area. The cold-storage owner rents space in the storage plant to dealers for storing their products, and he might be termed a landlord renting out space.

The charges by the cold-storage companies for the storage of butter are usually about one-fifth of a cent per pound for the first month and one-eighth of a cent per pound for each succeeding month. To this must be added insurance charges and interest on investment. For the purpose of completing the data for an estimate, it will be assumed that the average price of butter for storage is 35 cents, and the interest rate 7 per cent. On this basis the cost, per pound, of carrying butter in storage for a period of six months would be approximately as follows:

Storage charges, including insurance.	1 cent
Interest on investment.	$1\frac{1}{4}$ cents
Total.	$2\frac{1}{4}$ cents

Varying conditions, as length of time in storage, storage rates, price of butter and rate of interest, would, of course, modify the above estimate. It is a fair assumption to make that the cost of carrying butter during the storage season will be from 2 to 2½ cents a pound.

Should Cold Storage Butter be Branded?—A great deal of butter is kept in what are known as coolers by the butter dealers or merchants. Such butter is termed fresh butter until it is placed in cold storage plants. There is a bill before Congress at the present time which would require all butter held at a temperature below 45° to be classified as cold-storage butter. If such a bill should become law in its present form, all butter made in the creameries would be classified as storage butter as soon as it is churned, as all creameries use coolers for keeping their butter until it is shipped, when it is placed in refrigerator cars and shipped to the dealer. The latter may either place it in cold storage or carry it in his cooler from two weeks to sixty days, depending upon market conditions. There are a few firms who have coolers large enough to store two cars of butter, and they can control the temperature of the said coolers to almost any desired point.

The placing of a brand on butter of this character would be the means of causing the butter to sell for several cents per pound less, due to the prejudice that exists in the minds of many people against cold-storage goods of any kind. From a health standpoint there is no necessity for placing a brand on butter or cheese held in cold storage, for the reason that good butter will keep for a very long time without undergoing practically any change, if held below zero Fahrenheit.

Dr. Larson, Chief of the Dairy Division, reports having examined butter that was kept for three years in storage and which scored as high as 92 points when taken out. Where butter is held at a temperature between 5 and 10 degrees below zero there is very little danger of any change taking place during a period of nine to twelve months, especially if the butter is good. The authors know of a specific case in Chicago, where, owing to declining prices and in order to avoid a loss, a buyer carried

butter over from one season to the next. This butter was held in storage approximately eighteen months, at a temperature below zero, and when taken out of storage it showed little or no deterioration. Holding this length of time is, of course, not the rule, as most of the butter put into storage is not held over six months, or at most nine months.

Butter going into storage and butter coming out of storage are both sold by grade. The changes that take place in storage butter will depend, to a very large extent, upon the condition of the butter when going into storage, also upon the material from which it was made and the temperature at which it has been held. Butter held at high temperatures deteriorates quite rapidly and becomes rancid in time.

Butter for Storage.—One of the most common defects found in butter made from raw cream is what is known to the trade as cheesy or fishy flavor. The condition of the material used has a direct bearing upon the changes that take place. If butter is made from sweet cream, or cream nearly sweet, that has been efficiently pasteurized, there is very little danger of its going fishy; on the other hand, if the material used is not of good quality, the chances will be very favorable to its either becoming fishy or showing other deterioration defects that are found in poor storage butter.

In a large shipment of butter, made at Strawberry Point under the direction of one of the authors, the cream used had been efficiently pasteurized and its quality was all that could be desired in the way of flavor. The butter was held in New York in storage for between six and seven months. The average score on flavor, when entering storage, was 38.17, and on body 24.88; when coming out it was, flavor 38.25 and body 24.92.

The condition of the material used in the manufacture of butter, that is, the milk or cream, has a pronounced bearing upon the quality of the butter when it comes out of storage. Butter made from cream with a low acid and light salt will keep in storage better than butter made from cream with a high acid, especially if the acid has been developed in the cream without being controlled by the manufacturer.

The butter referred to above, which was made at Strawberry Point, was made from cream containing .68 of 1 per cent of acid, and it was ripened with a pure culture starter; it must be taken into consideration, however, that Strawberry Point at that time received whole milk of an exceptionally good quality. The milk was inspected on the stand by a man who had been engaged for that purpose, and any milk that was sour or tainted was rejected. At the present time very little butter is made under what is known as the whole-milk system. Possibly 90 to 95 per cent of the butter produced in this country is manufactured from so-called hand-separator cream. The result is that the producer has entire charge of cleansing separators and other utensils that come in contact with milk and cream, and some of the producers do not adopt the most sanitary methods in cleansing their separators and other utensils used in the dairy. In addition to this, there is, in many cases, the neglect to properly cool the cream after each separation. Some make a practice of mixing the warm cream with the previous lot that was separated without cooling, and the cream may also be held for a long time on the farm before it is delivered to the creamery or cream-buying station.

To the farmer the delivery of cream involves an economic problem. He cannot afford to go daily to the creamery or the cream-buying station, and the result is that he holds the cream until he has about a can of it, or enough to warrant him in making the trip to town. Cream of this character is usually more or less sour when it reaches the creamery where it is to be manufactured into butter. Some of it is too sour for pasteurization and the acidity must be reduced.

Various investigations have shown that butter churned from high-acid cream has a tendency to become fishy when placed in storage. The use of bad starters has an injurious effect also.

One of the leading butter houses in New York has instructed the creameries sending it butter not to use starters during the storage season. Investigations have demonstrated that for storage purposes low-acid and light salt give the best results under present conditions.

U. S. Bulletin 84, gotten out in 1906, by Gray and McKay, gives the results of investigations of the manufacture of butter under different conditions, and the keeping qualities of butter made under these varying conditions and stored at different temperatures. C. E. Gray, dairy expert for the Dairy Division at that time, had charge of the manufacturing of the butter, which was scored and criticized by McKay and Keiffer. Some of the butter for this experiment was made at Topeka, Kansas, from sour cream, and some at Monticello, Iowa, from sweet cream. The butter made from different lots of cream was divided and salted so that it contained from 1 to as high as $3\frac{1}{2}$ per cent salt. It was kept in storage at -10° , 10° and 32° F., and placed in the vestibule before being scored, the temperature of the vestibule at the time of scoring being 50° to 55° F. After the butter had been in the Booth cold storage for eight months, it was removed to the Iowa Experiment Station in a refrigerator car. It was found that on coming out of storage the butter made from sour cream in nearly every case had a pronounced fishy flavor, and that butter made from sweet cream containing light salt kept much better in storage than the butter made from the cream having a high per cent of acid. The two factors that gave the best results in this butter were low acidity in the cream and low per cent of salt in the butter.

It must not be understood from the above that it is absolutely necessary to have sweet cream to make butter that will possess a good keeping quality. Where cream is high in acid and is free from any objectionable flavors, its acidity can be reduced by limewater or milk of lime.

Some of the highest-selling butter found in our leading markets is made from cream that was originally high in acid, the acidity having been reduced and the cream re-ripened with a starter. Very poor cream is frequently found to be fairly low in acidity. This is due to inoculation with undesirable organisms, through neglect of proper care and cleansing of dairy utensils. If cream is high in acidity but possesses a clean acid flavor and the acidity is reduced, the quality of the butter will be good, and it has been demonstrated that butter made from such cream

will come out of storage in good condition. In fact, some of the leading butter dealers are now giving a preference, for storage purposes, to butter made in the large creameries where the acidity of the cream is reduced and the butter is manufactured under conditions that impart to it a good body and texture. The statement made elsewhere, that one of the large creameries made 25 million pounds of butter last year that graded Extras or Specials, demonstrates what can be and is being done. However, not all the butter made in large creameries is of this quality, owing to lack of care and skill in the manufacturing. Improper neutralizing, neglect to churn at a sufficiently low temperature and improper working are some of the causes of the production of butter of low quality or an inferior grade.

Working and Packing Butter for Storage Purposes.—Cream should be cooled until the fat is chilled to such a point that the granules of butter when they gather will be in sufficiently firm condition. The butter can then be sufficiently worked to thoroughly incorporate the salt, so that the finished product will not contain loose moisture and show up leaky when packed. (See chapters on Churning and Working Butter.)

Butter should be packed very closely in the packages, whether box or tub, to avoid air pockets. The tubs or boxes should be thoroughly steamed before paraffining, and care should be exercised to make sure that all parts of the wood are coated with hot paraffin. Care should also be taken to keep tubs and liners in a dry place.

For preparing tubs, boxes and liners for packing butter, see Chapter XIX.

Some butter is held in storage for more than a year, but it is very seldom that very much butter is held over nine months.

The Navy butter is put up under government instruction and is made from sweet cream, or cream containing not more than .25 of one per cent of acid, and pasteurized without the use of a starter.

The first to recommend churning the cream sweet was Mr. J. D. Leclair of St. Hyacinth Dairy School, Quebec, Canada. His method is outlined in a bulletin issued in 1904. The cream

used was from milk separated at the creamery and contained nearly 40 per cent fat. After being pasteurized and cooled to churning temperature it was held for about three hours. After the cream was put into the churn a large per cent (25 to 30 per cent) of starter was added and churning followed immediately. Butter made in this way secured first place at the leading Canadian Exhibitions in 1903. The beneficial effects of the use of good raw material and a good starter should again be noted. Leclair maintains that by adding a starter to sweet cream and churning immediately the flavor-producing substance can be developed in the butter after it is churned. He says that if sweet cream is churned with a portion of sour milk or starter the butter will have about the same flavor after standing as it would have if the cream were ripened. Some have tried to improve the flavor of butter by adding a starter directly to the butter and working it in with the salt. According to the Internal Revenue regulations, butter of this kind would be deemed adulterated and be subject to a tax of 10 cents a pound.

CHAPTER XXIV

COOLING FACILITIES FOR CREAMERIES

ONE of the most important points in connection with the successful operation of a creamery is the control of temperature. This control is important in the separation, pasteurization, ripening and churning processes, and in the use and preparation of starters. Conditions are frequently such that the raw as well as finished dairy products need to be stored. If temperature or cold storage conditions are not under control, dairy products will suffer in quality. Raw as well as finished products are very perishable and are best when fresh. Strictly and generally speaking, dairy products deteriorate with age, the nearer the producers of the raw material, manufacturers, and consumers of the finished products can be brought together, the better it is. Conditions of commerce and trade are such that butter needs to be preserved for some time before it reaches the consumer.

The preservation of butter depends on the checking of fermentations affecting the flavor of this product, and can best be accomplished by the use of a low temperature. There are various ways by which low temperature may be obtained in creameries. The system of refrigeration to be employed in a given creamery should be determined by local conditions.

Cooling Systems:

1. By the use of natural ice.
 2. By the use of mechanical refrigeration.
 3. By the use of cold water alone.
1. Most local creameries, within the ice-freezing belt, make use of natural ice. It is by far the most common method of refrigeration employed in creameries, and undoubtedly under average local conditions, represents the most economic method of obtaining low temperature. As a rule patrons have little

work to do during the winter and are willing to supply teams and help for a few days while the ice is being put up. The use of natural ice gives good satisfaction, especially when good, pure ice can be had within a reasonable distance from the creamery, and a proper and convenient place is provided in which to store the ice.

2. Mechanical refrigeration is undoubtedly gaining favor with creamery-men, as is evidenced by the increased number of mechanical refrigerating-plants installed in various creameries. The reasons for this increase are due, first, to centralization of creameries, second, to mild winters in certain sections and a consequent lack of natural ice, and third, to the greater convenience of mechanical refrigeration if properly operated.

Centralized creameries have so much more cooling to do than a local creamery, that a mechanical refrigerating-plant best serves their needs. Often centralized plants are located in large cities where an ice-manufacturing plant and cold storage plant may be run successfully in connection with the creamery. Prof. Erf¹ has conducted some experiments relative to the comparative cost of the two systems for creamery use. The following table shows the results, and indicates the comparative cost of cooling 100 pounds of butter to 30° F., including the cost of cooling the cream during manufacturing processes. These figures are also based upon a run of 10,000 pounds of milk per day.

	1	2	3	4
	Cents	Cents	Cents	Cents
Natural-ice system	20.1	18.2	17.5	17.1
Mechanical refrigeration	17.8	17.1	16.9	16.8

The different columns (1, 2, 3, 4) indicate different insulating material used, which cannot here be elaborated upon, except to say that it pays to insulate thoroughly.

The above results indicate that mechanical refrigeration is a little the cheaper. Its cost is quite constant under different conditions, while the cost connected with storing and using natural ice will vary greatly according to different localities.

¹ Creamery Journal.

3. Under certain conditions, intentional or unintentional, a creamery must be run without the use of ice, and without mechanical refrigeration. In such a case cold water is a necessity. One of the authors successfully operated a creamery for one season without any other cooling agent than water. The winter season had been warm and no ice was obtained nor was it obtainable at a reasonable cost. There was no room in the creamery for a mechanical refrigerating-plant, and even if there had been, no money was available with which to purchase such cooling facilities. The only thing to do was to close the creamery or cool with water.

The latter method was resorted to. The creamery was fortunate in having an unlimited supply of pure cold water coming from a mountain stream.

This water was made effective for cooling purposes by directing a constant flow through a galvanized iron tank in the refrigerator. The ice-box on the inside of the refrigerator was removed, and a closed galvanized iron tank put in its place. This tank was connected with an inflow and overflow at the top. A faucet for draining the tank was provided at the bottom in one corner. The tank was made straight on the side next to the wall, but sloping towards the wall on the side facing the refrigerator room. This was done so as to allow the dampness or sweat collecting on the outside to run down the sides and be collected in a trough, which conveyed it to the outside. A trap was connected with this outlet so as not to let in warm air. Such an arrangement gave very good satisfaction, though not so effective in cooling as ice.

The cream was cooled and kept cold by circulating a constant stream of water through the vat-jackets. The temperature of the water was never above 50° F.

The butter was disposed of locally while fresh. In creameries where it is necessary to hold butter any length of time, this system is undoubtedly less satisfactory, but under the above-mentioned conditions it gave good satisfaction.

The water-tank should never be made from wood, as wood is a very poor conductor of heat. Heavy galvanized iron is best.

NATURAL ICE SYSTEM

Kind of Ice-house.—When natural ice is stored, the first consideration is a good ice-house conveniently located to the creamery and refrigerator. When the creamery is first planned and built the ice-house should at the same time be provided for. It should preferably be adjacent to the refrigerator, so that the ice can be transferred directly from the house into the cooler, thus obviating much loss of ice and decreasing labor.

The various parts of the building, embracing the many details, will not here be enlarged upon, inasmuch as they can be more advantageously shown in plans. Students are referred to the different views shown in this chapter.

As will be seen, the construction of the ice-house depends to some extent upon the location and kind of refrigerator to be used. There are at least two different ways of locating the refrigerator in relation to ice-house: (1) Where the refrigerator is entirely separate from the ice-house, the ice to be transferred and placed either overhead or on one side of the refrigerator. (2) Where the refrigerator is combined with the ice-house and the ice is not moved for cooling purposes. This in turn may be arranged so as to have the ice storage overhead or on one side of the refrigerator. The ice-house needed in connection with this second method differs chiefly from that of the first in that better insulation is necessary and no ice-packing material is used, except on top. This latter type of creamery refrigerator, even though more expensive, is to be highly recommended, chiefly because labor is decreased, and the low temperature is uniformly maintained.

Reasonably high ground affords a good location for an ice-house. It is of importance that the ground should be thoroughly drained before the ice-house is built. If the ground is high, dry, and gravelly, no drainage may be needed, but under most conditions a drain should be run through the bottom. This drain should not be very deep. If the area to be drained is so large that one drain will not carry off the water, it is better to use two drains rather than to have one deep one.

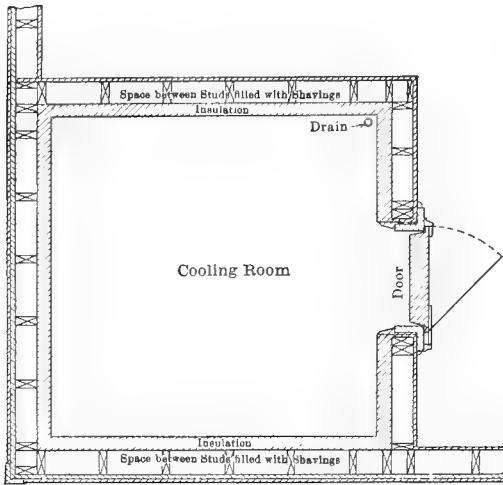

PLAN

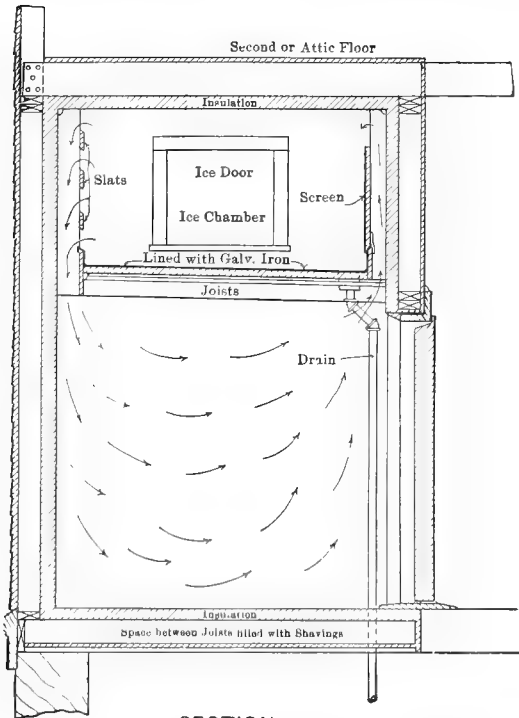

SECTION

FIG. 129.—Refrigerator with ice overhead.

CREAMERY COLD STORAGE CIRCULATION SYSTEM

ISSUED BY THE DAIRY COMMISSIONER
DEPARTMENT OF AGRICULTURE, OTTAWA

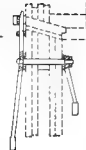
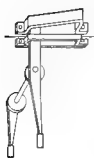

Door Fastener

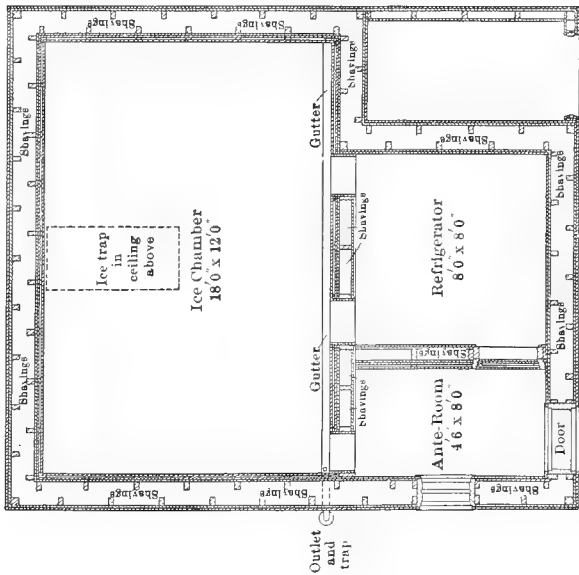
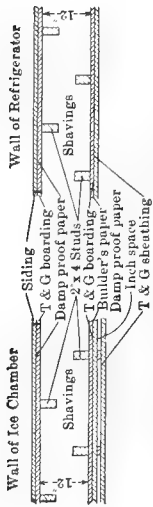
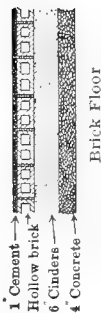

FLOOR PLAN

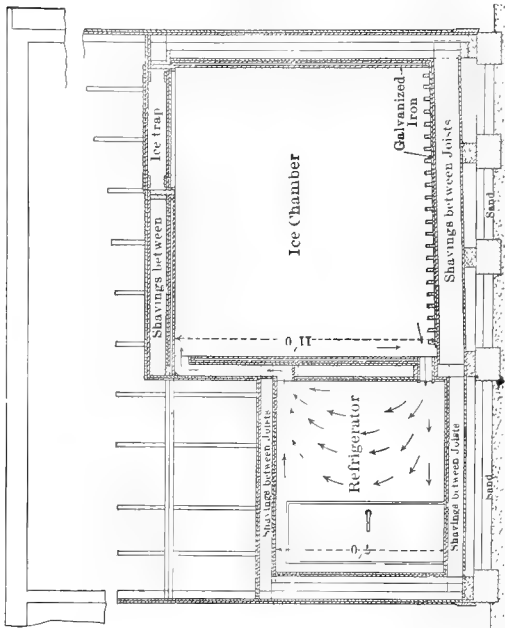

SECTION

FIG. 130.—Refrigerator and ice-house combined.
(From Report of Dairy Commission of Canada, 1906.)

Size and Shape of Ice-house.—The plan of the ice-house should be as nearly square as consistent with available space. A

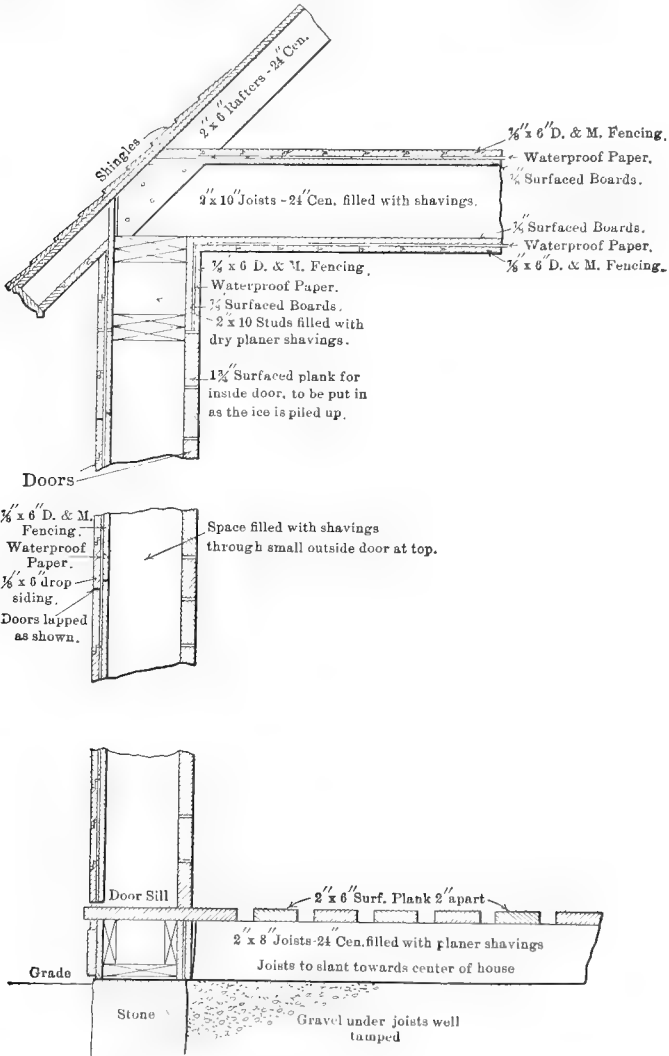

FIG. 131.—Construction detail of ice-house.

square building, having a certain length of wall around it, will hold more ice than an oblong building having an equal number of

feet of outside walls. The building should also be high in proportion to width and length. This will tend to preserve the ice, as proportionately less top surface is exposed to the air.

The size of the building will vary according to (1) amount of milk handled at the creamery, (2) whether ice is sold from creamery, and (3) whether ice is used for any other purposes, such as ice-cream freezing, cream shipping, etc. For creamery uses, the only basis on which to estimate is the amount of milk received.

For example, suppose a creamery is receiving 12,000 pounds of milk daily. This milk will produce about 2000 pounds of cream and about 600 pounds of butter. Suppose that the cream needs to be cooled from 90° F. down to 40° F. or a range of 50° F. One pound of ice will cool about 142 pounds of water 1° F. Calculations are made with water as basis. The results will thus be a little too high, but subsequent corrections will be made. If 1 pound of ice will cool 142 pounds of cream 1° F., it will require 50 pounds of ice to cool that amount of cream 50° F. By calculation from these figures we find that about 0.35 of a pound of ice is required to cool each pound of cream 50° F. and for cooling 2000 pounds of cream it will require 700 pounds. If it takes 700 pounds of ice daily for cooling the cream for eight months of the year, which is about the time the cream would have to be cooled by artificial means, it would take 168,000 pounds of ice per year. As the specific heat of cream is only about 0.7, the final amount needed for cooling the cream would be only 117,600 pounds, or about 59 tons.

The next consideration is the ice needed for cooling the butter. Roughly speaking, there will be about 600 pounds of butter. Suppose the butter needs to be cooled 30° F. Granting that the specific heat of butter is the same as that of water, it would require 30 pounds of ice to cool 142 pounds of butter 30° F. There will therefore be needed daily 126 pounds of ice for cooling the butter. As the specific heat of butter is only about 0.4, 51 pounds of ice are necessary daily. For eight months 12,240 pounds will be needed. The amount of ice needed in a refrigerator above that needed for cooling the butter cannot be calculated.

We may count on 25 per cent radiation and 25 per cent as an allowance for cooling tubs and packages. The total ice needed

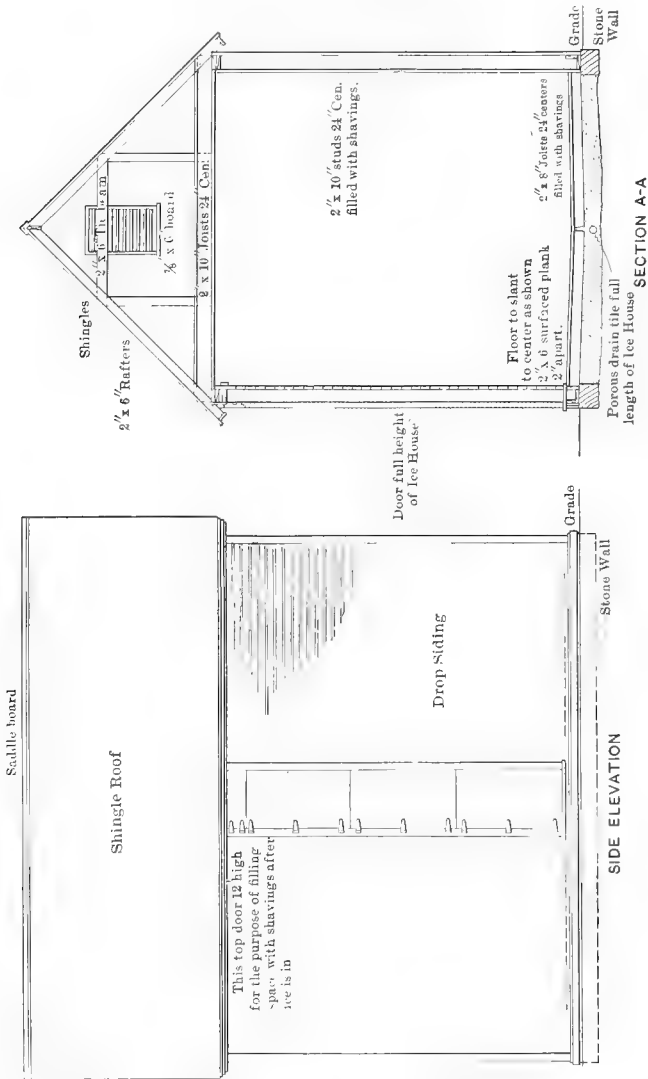

FIG. 132.—Construction details of ice-house.

for cooling the butter will then be 24,480 pounds, or about $12\frac{1}{4}$ tons.

Counting on 20 per cent loss incidental to transportation and melting in the ice-house, 89 tons of ice are needed for cooling the cream and butter the number of degrees mentioned above.

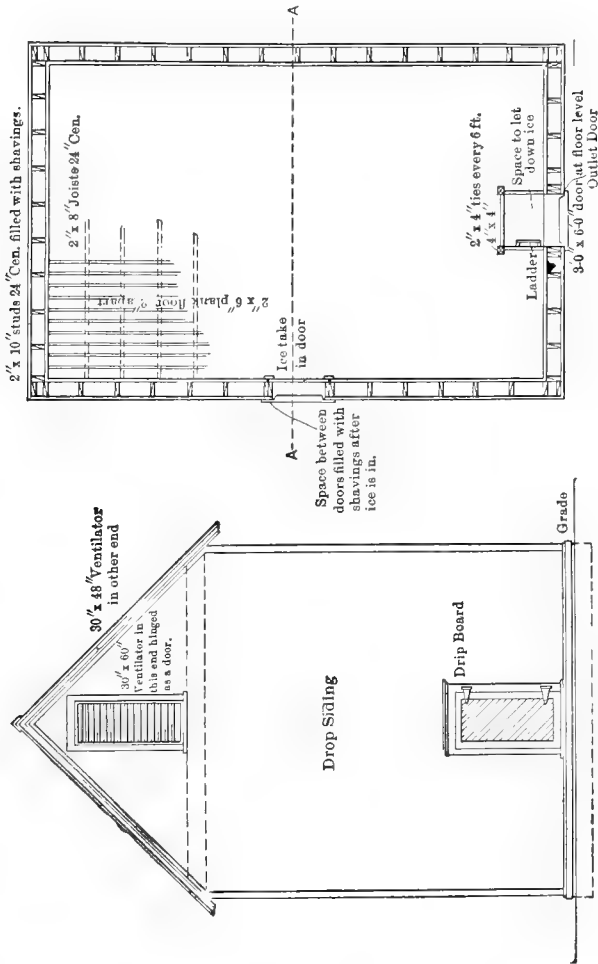

FIG. 133.—Construction details of ice-house.

One cubic foot of ice at 32° F. weighs 57.5 pounds. If 1 cubic foot of ice weighs 57.5 pounds, 89 tons would occupy a space equal to 3093 cubic feet, and would require an ice-house of dimensions approximately as follows: 16 feet high, 14 feet wide,

and 14 feet long. These dimensions are given only as examples. The height, width, and length may need to be changed to conform with local conditions. One thing should be kept in mind—it is always better to have an ice-house a little too large rather than too small.

Filling the Ice-house.—The chief objects to be sought in packing ice into an ice-house already properly constructed, are: first, to exclude circulation of air through the mass of ice and thus prevent melting; second, to pack it in such a manner that it can easily be removed in whole blocks; third, to pack it with material that will leave the ice as clean as is consistent with other important objects sought.

The packing material which is most commonly used in the central western states is sawdust. This is very efficient in excluding air, lasting, and usually cheap, but soils the ice so that considerable water needs to be used to rinse it, and as a consequence, considerable ice is wasted. Straw is used successfully. It leaves the ice much cleaner, but is not so effective in preserving the ice. Shavings are good, but as a rule are too expensive and not available. Some use no packing material other than ice and snow. When the blocks of ice are put into the ice-house, they are packed closely together. A man with a hatchet chips the blocks of ice in such a way as to fit them snugly together, and the small cracks are filled with fine ice and snow. The experience of the authors is that, by this method, the blocks of ice are likely to freeze solidly together, so that the ice cannot be removed without breaking it up into irregular pieces. This is hard work, and considerable ice is wasted.

Another method of filling ice-houses in successful use is that of running a shallow layer of water into the building and allowing it to freeze. The doors in the ice-house are opened during a protracted period of cold weather. The bottom of the ice-house is covered with building-paper. Water is run on top of this and allowed to freeze until a layer of ice about a foot in thickness has been obtained. Then another layer of paper is made to cover the ice and more water flooded on and frozen. This process is continued until the ice-house is filled. The paper

between the layers prevents the ice from freezing into one solid mass, and facilitates its removal.

When the ice is stored in an insulated house, combined with the refrigerator, no packing material is used except on the top of the ice. Shavings are good to pile on the top of ice when the ice-house has been filled. They are clean and effective in preserving the ice.

The cost of filling an ice-house with natural ice, obtainable within a distance of about 8 miles, will vary in different localities, but may be said to range between \$0.60 and \$1.25 per ton. The creamery furnishes a man to pack it into the ice-house.

Source of Ice.—The ice for creamery use should be obtained from as pure water as possible. A large running stream is always better than a small polluted stream. Usually the creamery can co-operate with butchers, restaurants, hotel-men, and other local ice-users in building a dam in a suitable stream. The ice can also as a rule be harvested cheaper by co-operation.

Some creameries have constructed ice-ponds near the ice-house. If there is a clay or impervious bottom, this works successfully and economically. The pond is filled and kept filled from the creamery water-supply or from a tile drain inlet. Care should be taken not to use stagnant water or water in which weeds and other rubbish have been allowed to accumulate. The pond should be deep enough so that the water will not freeze to the bottom and produce dirty ice. The pond should also be filled with water to overflowing when freezing is begun; otherwise slush and snow are likely to accumulate together with dust from the fields and roads, producing impure ice.

The ice is best when frozen from the top down. A hole is bored in the ice and kept open during the freezing process. Through this opening the pond is supplied with water as rapidly as it subsides. When the water is solidly up against the bottom of the ice it will show in the opening or hole in the ice.

To construct an ice-pond on gravelly soil is useless, and to pack such a pond with a sufficiently thick layer of clay to prevent leakage of water is, under most conditions, impracticable.

USE OF ICE IN COOLING CREAM

1. Directly.
2. Indirectly.

1. The cooling of cream in creameries by putting ice directly into the cream has been much practiced in the past. The method is yet used considerably, especially where the old open vats are still in use. Some of these open vats are jacketed and some are not. Cream in unjacketed vats could not well be cooled in any other way than by using ice directly in the cream and stirring until cold. To keep cold any length of time, considerable excess of ice needs to be used.

Such a method of cooling cream has its advantages as well as disadvantages. The latter, however, clearly outweigh the former.

The advantages are that the cream can be cooled in a very short time, and it does not require any special investment for up-to-date ripening-vats, nor special machinery for the purpose of pumping the cooling medium.

The chief disadvantages are: first, impurities and undesirable germs are liable to be introduced, which injure the quality of the cream and otherwise work harm to the quality and keeping property of the butter; second, the melting of the ice would dilute the cream. This would render the cream less sour, impart a marked flat, insipid taste to the cream and butter, and produce more buttermilk which, if it contained a certain per cent fat, would mean a greater loss of fat during the churning process.

The use of ice directly in the cream for cooling purposes should not be resorted to unless it is necessary. With the best quality of cream this method is still more unsatisfactory, as it greatly lowers the quality of the butter. With cream in very poor condition previous to ripening, the chances for lowering the quality of butter are not so great.

2. The indirect cooling of cream with ice is by far the better method. With the use of our up-to-date ripening-vats, the cooling of cream is an easy matter; but where the creamery is already in possession of a good open vat and the management not disposed to discard it to install a new one, the question is different.

Some open vats have a jacket and special open space at one end for holding crushed ice. These vats will control and hold temperature better than those that simply have a jacket around them. The cooling of cream on a large scale by circulating ice-water through the jacket is, at best, a slow process, usually too slow to be effective and practical.

This cooling process is carried out by mixing the ice and water together in a separate vat to which a rotary pump is attached, forcing the water through the jacket and again returning it to the ice and water-tank to be cooled. The slowness of this cooling process can in a measure be overcome by mixing salt with the ice and water. This will cause the ice to melt faster, and consequently cool the brine to a lower degree of temperature than it is possible to obtain with water and ice.

In case it is desirable, a set of coils can be made which will fit into the open vat. The inlet and outlet of these coils can be connected by means of rubber hose with the pipes conveying the brine to and from the ripener. The coils can be made to move up and down, by means of a rope attached to and leading from the coils through a pulley near the loft and fastened to a small crank at the end of a shaft. When the shaft turns the crank will also turn and cause the coils in the vat to move up and down. In the absence of a special up-to-date ripener, this manner of cooling works very satisfactorily.

A butter refrigerator containing a tank, as already described, could be cooled by pumping brine through it in a similar manner, as described for cream cooling, except that no coils are needed.

MECHANICAL REFRIGERATION

Application in Creameries.—Mechanical refrigeration on a small scale has been considered expensive and impracticable until within recent years. The science of producing cold artificially has been simplified and reduced to such a practical basis that it is now used in many large plants as well as in smaller plants where formerly natural ice was used altogether. Where at least 10,000 pounds of milk, or its equivalent in cream,

are received daily during the summer months, mechanical refrigeration is considered practicable.

On another page a table of comparative costs of natural ice and mechanical refrigeration is given. It was also stated in that connection that the cost of mechanical refrigeration would vary under different conditions. The chief factors affecting the cost of mechanical refrigeration may be said to be similar to those affecting the economic running of the remaining machinery, such as kind of fuel used, skill of firemen, style and condition of boiler, proportion of boiler power to work done, the correlative size of all machinery, kind of insulation and care of cooling-rooms, and efficiency of compressor and whole refrigerating system.

Chemicals Used for Mechanical Refrigeration.—The most common substances used in mechanical refrigeration are ammonia and carbonic acid. A number of others are in use, but from a creamery standpoint, these only are of importance. Ammonia is the most used. It is efficient, cheap, and not so dangerous to life and property as are some of the others. Anhydrous ammonia has a boiling-point of 27° below zero at atmospheric pressure. The latent heat of ammonia is also great. Ammonia has great chemical stability, and is not explosive in nature; it attacks copper and brass, but has no effect upon iron and steel pipes. If ammonia should escape through a leak into a room, the operator can protect himself from the effects of the gas by breathing through a wet sponge held in the mouth. Ammonia leaks may be detected by holding a glass rod dipped in hydrochloric acid to the place where the leak may be. When ammonia comes in contact with hydrochloric acid, white fumes are formed.

Carbonic acid is used considerably in Europe, and is chiefly favored because the gas is not highly poisonous; in case of leak it does not soil contents of refrigerator, and it liquefies at a high temperature (90° to 100° F.), and is therefore favored in tropical climates.

Principles of Producing Cold Artificially.—The chief principle involved in producing artificial cold is that when a substance passes from a liquid into a gaseous state, a definite amount of

latent heat is absorbed. When water in a kettle on the stove begins to boil and passes off into steam, no higher temperature can be reached. No matter how much heat is applied under those same conditions, the temperature remains the same. This extra heat is used in transforming the water into steam. If this steam were confined, and that heat removed, by cooling, the steam would again pass into a liquid state. We are familiar with the coolness produced by rapid evaporation of perspiration from the body. Mechanical refrigeration is virtually a process of evaporation of the cooling media, during which heat is absorbed, and liquefaction of the cooling medium by compression and cooling to remove that absorbed heat. To increase the ability of the cooling medium to absorb heat it is compressed and liquefied. So it may be said that in any compression refrigerating system three separate operations are necessary to form the complete cycle of mechanical refrigeration, viz.:

1. Compression of the ammonia gas.
2. Condensation of the ammonia gas.
3. Expansion of the ammonia gas.

1. The machine which causes the compression of the ammonia gas is called the compressor. In construction it is much like a steam-engine. Small machines are single, but large machines are double acting. Gas is drawn in, on the suction stroke, compressed and discharged on the return stroke. The pressure generated varies between 120 and 175 pounds per square inch. During the compression heat is developed in proportion to pressure exerted. The greater the pressure the higher the temperature of the gas. Part of the heat of compression is carried off by means of a continuous stream of water running through a jacket around the cylinder.

2. From the compressor the gas is forced through the pipes into the condensing coils, in which the warm compressed gas is cooled still more. When sufficient heat has been removed from this gas, it assumes a liquid condition and is ready to expand into a gaseous form for the purpose of absorbing heat and producing cold. During the cooling and condensing processes each pound of ammonia parts with about 560 units of heat, which amount

can again be absorbed when it expands into gas at the lower pressure.

3. This liquefied gas, which is still under great pressure, is then admitted through what is termed the expansion-valve. This valve is especially constructed for that purpose, and has only a very minute opening in it for the admission of the liquid ammonia. On the expansion side the pressure is low (20 to 30 pounds). As the liquid ammonia emerges from the high-pressure side through the expansion-valve into the expansion side, it forms a gas. This expanded gas may then be circulated through coils for cooling purposes. From there it passes back into the suction side of the compressor ready to go through another similar cycle.

From the above description it will be seen that there are two sides to the system, the expansion side and the compression side. The compression side extends from the compressor to the expansion-valve; the expansion side from the expansion-valve to the suction side of the compressor, inclusive.

Transferring the Cold.—The methods of transferring the cold to the different places in the building vary. There are two systems, viz.:

1. Direct Expansion.
2. Brine System.

1. By the direct-expansion system the condensing-pipes are extended to the room or place at which the cooling is to be done. An extended set of expansion coils then convey the gas which absorbs the heat. A lower temperature can be produced by this method than with the brine system.

2. In the brine system a large brine-tank is placed somewhere in the creamery at a place most convenient with respect to cooling. This tank contains a strong solution of brine. The chief reason why brine is used in preference to water is that brine has a very low freezing-point. This will vary with different degrees of saturation.

Either one, sodium chloride (common salt), or calcium chloride, may be used for brine. The latter is considered the better chiefly because it is not so hard on the pipes and it keeps

the brine pipes cleaner than does a salt brine. The tables give properties of brine made from these two substances.

SHOWING PROPERTIES OF SOLUTION OF SALT. (SIEBLY).

(Chloride of Sodium).

Per Cent of Salt by Weight	Pounds Salt per Gallon of Solution	Degrees on Sal-ometer at 60° F.	Weight per Gal. at 39° F.	Specific Gravity at 39° F. 4° C.	Specific Heat	Freezing-point, Fahr.	Freezing-point, Celsius
1	0.084	4	8.40	1.007	0.992	30.5	- 0.8
2	0.169	8	8.46	1.015	0.984	29.3	- 1.5
2.5	0.212	10	8.50	1.019	0.980	28.6	- 1.9
3	0.256	12	8.53	1.023	0.976	27.8	- 2.3
3.5	0.300	14	8.56	1.026	0.972	27.1	- 2.7
4	0.344	16	8.59	1.030	0.968	26.6	- 3.0
5	0.433	20	8.65	1.037	0.960	25.2	- 3.8
6	0.523	24	8.72	1.045	0.946	23.9	- 4.5
7	0.617	28	8.78	1.053	0.932	22.5	- 5.3
8	0.708	32	8.85	1.061	0.919	21.2	- 6.0
9	0.802	36	8.91	1.068	0.905	19.9	- 6.7
10	0.897	40	8.97	1.076	0.892	18.7	- 7.4
12	1.092	48	9.10	1.091	0.874	16.0	- 8.9
15	1.389	60	9.26	1.115	0.855	12.2	-11.0
20	1.928	80	9.64	1.155	0.829	6.1	-14.4
24	2.376	96	9.90	1.187	0.795	1.2	-17.1
25	2.488	100	9.97	1.196	0.783	0.5	-17.8
26	2.610	104	10.04	1.204	0.771	-1.1	-18.4

PROPERTIES OF SOLUTION OF CHLORIDE OF CALCIUM. (SIEBLY)

Per Cent by Weight	Specific Heat	Specific Gravity at 60° Fahr.	Freezing-point in Degrees Fahr.	Freezing-point in Degrees Cels.
1	0.996	1.009	31	- 0.5
5	0.964	1.043	27.5	- 2.5
10	0.896	1.087	22	- 5.6
15	0.860	1.134	15	- 9.6
20	0.834	1.182	5	-14.8
25	0.790	1.234	- 8	-22.1

The expansion-coils pass through the brine-tank and cool the brine. Special pumps force the cold brine through pipes to the cream vat, cooling coils, ice-cream freezer, etc.

For creameries the brine system is the only practical system. It is preferred because, first, cold can be stored in an insulated brine-tank and used at will without running the compressor. (In case of a prolonged stoppage due to some accident a brine made by a mixture of ice-water and salt could be temporarily substituted); second, less ammonia is required to charge the system; third, fewer couplings and less ammonia pipes are necessary. This latter would decrease the danger of ammonia leakage and cost of pipes.

CHAPTER XXV

ECONOMIC OPERATION OF CREAMERY

INASMUCH as it is impossible within the limited space of this work to enter upon a detailed discussion of the various principles and practices of operating boilers, engines, mechanical refrigerators, and other creamery machinery, only a few of the chief factors common to creamery practice and affecting economic operation shall be discussed here. For more complete information students are referred to works treating specially of these phases.

Firing the Boiler.—Much fuel can be wasted or saved according to the completeness with which the combustion occurs. This again depends upon the manner of firing, upon the regulation of the draught, and upon the kind of boiler. The fire on the grates should never be too thick nor should too much coal be loaded on the fire at any one time. A thin, even fire permits of a more complete combustion than is possible when clinkers and cinders are allowed to accumulate on the bottom of the fire and a heap of unburned coal on top. By this latter method of firing, the grates are likely to be injured.

To get the most heat from the coal the draught should be regulated. The combustible part of the coal is of two kinds: first, the fixed carbon, and second, the volatile matter. The former is the coke or the part of coal which is seen on the grates as a mass of glowing fire. The latter consists of the gases which pass off when a certain temperature is reached, and which, when mixed with a certain amount of air at a given temperature, will burn. The heavy black trail of smoke seen rising from chimneys is partially wasted coal. If the grates are choked with a thick fire, no air can pass through, and the volatile parts of coal pass off without being burned.

Burning Wood or Coal.—In some localities this question is of minor importance, as conditions may be such that coal only can be used. In other sections, where both are obtainable, it is of great importance. The following table¹ shows figures obtained at five factories in Wisconsin where soft coal was burned and five others where wood was used.

DAILY FUEL USED AT SEVERAL CREAMERIES

Pounds of Milk Skimmed per Day	Pounds of Soft Coal Burned	Cost of Coal per Ton	Estimated Cost per Day
3,500	500	\$3.55	\$0.90
8,000	400	3.00	0.60
23,000	1000	4.05	2.00
6,000	300	3.50	0.50
5,300	500	3.15	0.80

Pounds of Milk Skimmed per Day	Cords of Wood Burned	Price per Cord	Estimated Cost per Day
2,000	$\frac{1}{4}$	\$1.25	\$0.32
3,400	$\frac{1}{6}$	2.25	0.37
6,500	$\frac{1}{4}$	1.25	0.32
3,800	$\frac{1}{6}$	2.25	0.37
4,500	$\frac{1}{3}$	1.80	0.60

These are the best obtainable figures of comparison under creamery conditions.

If wood is burned the dryness of it is an important consideration. If the wood is wet its power of producing heat is greatly lessened, as a certain amount of heat is used in evaporating the water in the wood. Air-dry wood will contain from 12 per cent to 25 per cent water. The quality of coal is another variable factor. In general, and from the table which follows, it might be said that $2\frac{1}{2}$ pounds of wood are equal to 1 pound of lump coal.

¹ Farrington in Hoard's Dairyman.

The following comparative table is given by Kent:

Hickory or hard maple,	weight per cord 4500 lbs.= 1800 to 2000 lbs. of coal.
White oak,	weight per cord 3850 lbs.= 1540 to 1715 lbs. of coal.
Poplar, chestnut and cedar,	weight per cord 2350 lbs.= 940 to 1050 lbs. of coal.
Pine,	weight per cord 2000 lbs.= 800 to 925 lbs. of coal.

Whether a creamery can economically use slack or lump coal is another question worth considering. Slack coal is used very little in local creameries, mainly because it is more difficult to use in firing. Usually help is scarce, and coal which requires less attention in firing is preferred. In the second place slack coal is subject to spontaneous combustion and likely to set buildings afire. Some, if not all insurance companies, discriminate against creameries using slack coal as fuel. Thirdly, special grates (rocking grates) are essential to get best results from using slack. Fourthly, slack coal is dirty and the dust from it will lodge all over in the boiler and engine room.

Slack coal, where conditions are at all favorable for its use, is, as a rule, cheap to burn. According to experimental data, 1 pound of slack coal will produce about 4 pounds of steam, and 1 pound of lump coal will produce about 6 pounds of steam. The price of the two will vary, but usually the relation is, slack coal, \$1.25 per ton; lump coal, \$3.25 per ton. If 1 pound of lump coal produces 6 pounds of steam, a ton will produce 12,000 pounds. If 1 pound of slack coal produces 4 pounds of steam, to produce 12,000 pounds will require 2992 pounds of slack coal, which would cost \$1.87. The difference in producing 12,000 pounds of steam in favor of slack coal would then be \$1.38.

Daily Weighing of Coal Used.—The advantage of daily weighing of coal used in creameries cannot be too strongly emphasized. That business phase of creamery work has been much neglected in the past. If the coal used daily is not weighed, a serious loss or leak may continue without detection. Firing the boiler is a daily occurrence, and if a small loss occurs, the total loss at the end of the year will cut short the profits.

The weighing can be done conveniently by fitting a box similar in shape to an enlarged flat-sided curd pail on a pair of platform scales. After the scale and box have been purchased

there are no additional expenses and very little extra labor required.

Cleaning the Boiler. The amount of coal used will vary with several factors, viz., cleanliness of flues, sediment in the boiler, condition of fire, kind of boiler, steam leaks, pipe insulation, etc. The two first factors are frequently neglected. The flues should be cleaned every morning before the day's run. The inside of the boiler should be kept clean. Heavy scale on the inside of the boiler and flues, and heavy sediments on the bottom of the boiler, should never be allowed to accumulate. Some water naturally contains a large amount of minerals and leaves a heavy deposit in the boiler. The operator should learn to know the condition of the water, and the frequency of cleaning the inside of the boiler should be governed accordingly. One cleaning per month is sufficient with most water. In some instances, one cleaning per week is necessary.

The collection of scale and sediment within the boiler affects the economic operation in at least three ways: First, more fuel is needed; second, the boiler itself is likely to warp; third, foaming or priming of the boiler is likely to occur. If scale clings to the flues when washed, it may be removed by putting some sal-soda and water into the boiler and boiling for several hours. Some use a boiler compound for preventing scales. This is not necessary nor to be recommended except in extreme cases where the mineral content of the water is very high. The boiler should be frequently blown off at low pressure.

Priming of Boilers.—When considerable water passes over with the steam the boiler is said to be priming. This water in the steam interferes with the running of the engine, filling the engine-cylinder and resulting in broken piston or cylinder-head. The engine jerks and thumps to such an extent that there is danger of breaking other parts of the machinery.

The foaming or priming of boilers is due chiefly to:

1. Too much water in the boiler.
2. Working the boiler beyond its capacity.
3. Allowing mud and minerals to accumulate in boiler.
4. Using too much of certain boiler compounds.

5. Using water which naturally contains a large percentage of certain minerals conducive to foaming.

The Injector.—The injector on the boiler frequently causes the operator some annoyance by refusing to work. The common causes of this are:

1. Too low boiler steam pressure.
2. Steam obtained from a pipe already supplying steam for other purposes.
3. Leaks in suction pipe due to shortage of supply pipe or holes in pipe.
4. Too hot supply water.
5. Scale in injector, preventing proper working of valves.
6. Steam containing too much water.

Oil-separators.—Considerable saving can be accomplished in a creamery if the exhaust steam is utilized. This steam may be used for pasteurizing the skim-milk, for heating the milk previous to separation, for heating the creamery, and for heating the water for the boiler.

The exhaust steam contains considerable oil and should be purified before it is used for any other purposes. Several forms of steam purifiers are on the market. They are simple, inexpensive, and can be attached to the exhaust-pipe of any engine.

All steam and water pipes should be carefully drained in the winter to prevent freezing.

Belt, Pulley and Speed Calculation.—The length of a belt may best be determined by measuring over the two pulleys with a tape or a string.

To calculate the size of a drive pulley when the speed of it is known the diameter of the driver pulley is multiplied by its speed and the product divided by the speed of the driven pulley, the quotient will be the diameter or size of the needed pulley.

To calculate the speed of a driven pulley, multiply the diameter by the speed of the driver pulley and divide the product by the diameter of the driven pulley; the quotient is the speed or number of revolutions per minute.

APPENDIX

LEGAL STANDARDS FOR DAIRY PRODUCTS, 1920

States	Milk			Skim-milk	Cream	Butter	Whole-milk Cheese	Condensed Milk	
	Total Solids	Solids Not Fat	Fat					Total Solids	Fat
	%	%	%	%	%	%	%	%	%
Alabama				None;	municipal control				
California	8.5	3		9.25	18	80	1.30	21.5	7.7
Colorado	8.5	3.25		9.25	18	82.5	35	28	7.7
Connecticut	11.75	8.5	3.25						
District Columbia		9	3.5	9.3	20	2.83			
Delaware				None;	municipal control				
Florida				None;	municipal control				
Georgia	12	8.5	3.25	9.25	18	82.5	50	28	7
Hawaii	11.5	8.5	3					28	7.7
Idaho	11	8	3	9.25	18	82.5	1.30	28	7.7
Illinois		8.5	3	9.25	18	82.5	50	28	7.7
Indiana		8.5	3.25	9.25	18	82.5	50	28	
Iowa	12.5		3		15	80			
Kansas			3.25						
Kentucky	12	8.5	3.25	9.25	18	82.5	50	28	7.7
Louisiana		8.5	3.5	8.00	18	82.5	50	28	7.7
Maine	11.75	8.5	3.25						
Maryland	12.5		3.5					3	
Massachusetts	12.15		3.35	9.3	15				
Michigan	12.5		3	Sp.gr. 32	15				
Minnesota	13		3.5		20	80	45		
Missouri		8.75	3.25	9.25	18	82.5	50	28	7.7
Montana	12	9	3		15				
Nebraska			3		18				
New Hampshire	12			9	18	80			
New Jersey	12		3		16				
New Mexico				None;	municipal control				3
New York	11.5		3						
North Carolina		8.5	3.25	9.25	18	82.5	4.50	28	7.7
North Dakota	12		3		15				
Ohio	12		3			80		3	
Oklahoma	12.5		3		18			28	7
Oregon	12.2	9	3.2		20		1.30	22	4.5
Pennsylvania	None;	municipal control			15				
Porto Rico	12		3						
Rhode Island	12		2.5						
South Carolina				None;	municipal control				
South Dakota		8.5	3.25	9.25	18	80	4.50	28	7.7
Tennessee		8.5	3.25		18	82.5	4.50	28	7.7
Texas		8.5	3.25						
Utah	12	9	3.2		18	80		28	7
Vermont	12.5	9.25	4						
Virginia		8.5	3.25	9.25	18	82.5	4.50	28	7.7
Washington	12	8.75	3.25	9.3	18		1.30		
Wisconsin		8.5	3	9	18	82.5	50	28	8
Wyoming	12		3.4			80	1.20		3

1 Per cent of fat.

2 Not over 12 per cent water or 5 per cent salt.

3 Proportion of fat to total solids must be the same as in the crude milk.

4 Per cent of fat in total solids

5 May and June, 12.

METRIC SYSTEM¹**METRIC SYSTEM OF WEIGHTS AND MEASURES AND
TABLES FOR THE CONVERSION OF METRIC
WEIGHTS AND MEASURES INTO CUSTOMARY
UNITED STATES EQUIVALENTS AND THE REVERSE.**

In the metric system the *meter* is the base of all weights and measures.

The meter was intended to be, and is very nearly, one ten-millionth part of the distance measured on a meridian of the earth from the equator to the pole, and equals about 39.37 inches or nearly 3 feet $3\frac{3}{8}$ inches.

The meter is the primary unit of length.

Upon the meter are based the following primary units: the square meter, the are, the cubic meter or stère, the liter, and the gram.

The square meter is the unit of measure for small surfaces; as the surface of a floor, table, etc.

The are is the unit of land measure; this is a square whose side is 10 meters in length, and which contains 100 square meters.

The cubic meter or stère is the unit of volume; this is a cube whose edge is 1 meter in length.

The liter is the unit of capacity; this is the capacity of a cube whose edge is one-tenth of a meter in length.

The gram is the unit of weight; this is the weight of distilled water contained in a cube whose edge is the one-hundredth part of a meter; a gram is therefore the one-thousandth part of a kilogram, and the one-millionth part of a metric ton.

¹ From The American Chamber of Commerce.

MEASURES OF LENGTH

Metric Denominations and Values		Equivalents in Denominations in Use
Myriameter	10,000 meters	6.2137 miles
Kilometer	1,000 meters	.62137 mile, or 3,280 ft. 10 in.
Hectometer	100 meters	328 feet 1 inch
Dekameter	10 meters	393.7 inches
Meter	1 meter	39.37 inches
Decimeter1 meter	3.937 inches
Centimeter01 meter	.3937 inch
Millimeter001 meter	.0394 inch

MEASURES OF SURFACE

Metric Denominations and Values		Equivalents in Denominations in Use
Hectare	10,000 square meters	2.471 acres
Are	100 square meters	119.6 square yards
Centare	1 square meter	1550 square inches

MEASURES OF CAPACITY

Metric Denominations and Values			Equivalent in Denominations in Use	
Names	No. of Liters	Cubic Measure	Dry Measure	Liquid or Wine Measure
Kiloliter or stere	1000	1 cubic meter	1.308 cu. yds.	264.17 gals.
Hectoliter	100	.1 cubic meter	2 bush. 3.35 pks.	26.417 gals.
Dekaliter	10	10 cu. decimeters	9.08 quarts	2.6417 gals.
Liter	1	1 cu. decimeter	.908 quart	1.0567 qts.
Deciliter1	.1 cu. decimeter	6.1022 cu. ins.	.845 gill
Centiliter01	10 cu. centimeters	.6102 cu. in.	.338 fl. oz.
Milliliter001	1 cu. centimeter	.061 cu. in.	.27 fl. dram

WEIGHTS

Metric Denominations and Values			Equivalents in Denominations in Use
Names	Number of Grams	Weight of What Quantity of Water at Maximum Density	Avoirdupois Weight
Metric ton.....	1,000,000	1 cubic meter	2204.6 pounds
Quintal.....	100,000	1 hectoliter	220.46 pounds
Myriagram.....	10,000	1 dekaliter	22.046 pounds
Kilogram or kilo.....	1,000	1 liter	2.2046 pounds
Hectogram.....	100	1 deciliter	3.5274 ounces
Dekagram.....	10	10 cubic centimeters	.3527 ounce
Gram.....	1	1 cubic centimeter	15.432 grains
Decigram.....	.1	.1 cubic centimeter	1.5432 grains
Centigram.....	.01	10 cubic millimeters	.1543 grain
Milligram.....	.001	1 cubic millimeter	.0154 grain

COMMON MEASURES AND WEIGHTS, WITH THEIR METRIC EQUIVALENTS

The following are some of the Measures in common use, with their equivalents in measures of the Metric System

Common Measures	Equivalents	Common Measures	Equivalents
1 inch	2.54 centimeters	1 cord	3.624 steres
1 foot	.3048 meter	1 liquid quart	.9465 liter
1 yard	.9144 meter	1 gallon	3.86 liters
1 rod	5.029 meters	1 dry quart	1.101 liters
1 mile	1.6093 kilometers	1 peck	8.811 liters
1 square inch	6.452 sq. centimeters	1 bushel	35.24 liters
1 square foot	.0929 square meter	1 ounce av'd'p	28.35 grams
1 square yard	.8361 square meter	1 pound av'd'p	.4536 kilogram
1 square rod	25.29 square meters	1 ton (2000 lbs.)	.9072 met. ton
1 acre	.4047 hectare	1 ton (2240 lbs.)	1.016 metric ton
1 square mile	259 hectares	1 grain troy	.0648 gram
1 cubic inch	16.39 cu. centimeters	1 ounce troy	31.104 grams
1 cubic foot	.02832 cubic meter	1 pound troy	.3732 kilogram
1 cubic yard	.7646 cubic meter		

TABLE FOR THE CONVERSION OF METRIC WEIGHTS AND MEASURES
INTO CUSTOMARY UNITED STATES EQUIVALENTS AND THE
REVERSE.

From the legal equivalents are deduced the following tables for converting United States weights and measures.

METRIC TO CUSTOMARY

Linear Measure

Meters = Inches	Meters = Feet	Meters = Yards	Kilometers = Miles
1 = 39.37	1 = 3.28087	1 = 1.093623	1 = 0.62137
2 = 78.74	2 = 6.56174	2 = 2.187246	2 = 1.24274
3 = 118.11	3 = 9.84261	3 = 3.280860	3 = 1.86411
4 = 157.48	4 = 13.12348	4 = 4.374492	4 = 2.48548
5 = 196.85	5 = 16.40435	5 = 5.468175	5 = 3.10685
6 = 236.22	6 = 19.68522	6 = 6.561738	6 = 3.72822
7 = 275.59	7 = 22.96609	7 = 7.655361	7 = 4.34959
8 = 314.96	8 = 26.24696	8 = 8.748984	8 = 4.97096
9 = 354.33	9 = 29.52783	9 = 9.842607	9 = 5.59233

CUSTOMARY TO METRIC

Linear Measure

Inches = Centimeters	Feet = Meters	Yards = Meters	Miles = Kilometers
1 = 2.54	1 = 0.304798	1 = 0.914393	1 = 1.60935
2 = 5.08	2 = 0.609596	2 = 1.828787	2 = 3.21869
3 = 7.62	3 = 0.914393	3 = 2.743179	3 = 4.82804
4 = 10.16	4 = 1.219191	4 = 3.657574	4 = 6.43739
5 = 12.70	5 = 1.523989	5 = 4.571966	5 = 8.04674
6 = 15.24	6 = 1.828787	6 = 5.486358	6 = 9.65608
7 = 17.78	7 = 2.133584	7 = 6.400753	7 = 11.26543
8 = 20.32	8 = 2.438382	8 = 7.315148	8 = 12.87478
9 = 22.86	9 = 2.743179	9 = 8.229537	9 = 14.48412

SQUARE MEASURE			CUBIC MEASURE	
Square Centimeters = Square Inches	Square Meters = Square Feet	Square Meters = Square Yards	Cubic Meters = Cubic Feet	Cubic Feet = Cubic Meters
1 = 0.155	1 = 10.764	1 = 1.196	1 = 35.315	1 = 0.02832
2 = 0.310	2 = 21.528	2 = 2.392	2 = 70.631	2 = 0.05663
3 = 0.465	3 = 32.292	3 = 3.588	3 = 105.947	3 = 0.08495
4 = 0.620	4 = 43.055	4 = 4.784	4 = 141.262	4 = 0.11326
5 = 0.775	5 = 53.819	5 = 5.980	5 = 176.584	5 = 0.14158
6 = 0.930	6 = 64.583	6 = 7.176	6 = 210.899	6 = 0.16990
7 = 1.085	7 = 75.347	7 = 8.372	7 = 247.209	7 = 0.19821
8 = 1.240	8 = 86.111	8 = 9.568	8 = 282.525	8 = 0.22653
9 = 1.395	9 = 96.874	9 = 10.764	9 = 317.840	9 = 0.25484

SQUARE MEASURE			LIQUID MEASURE		
Square Inches = Square Centimeters	Square Feet = Square Meters	Square Yards = Square Meters	Centimeters = Fluid Ounces	Liters = Quarts	Liters = Gallons
1 = 6.452	1 = 0.09290	1 = 0.836	1 = 0.338	1 = 1.0567	1 = 0.26417
2 = 12.903	2 = 0.18581	2 = 1.672	2 = 0.676	2 = 2.1134	2 = 0.52834
3 = 19.354	3 = 0.27871	3 = 2.508	3 = 1.014	3 = 3.1700	3 = 0.79251
4 = 25.806	4 = 0.37161	4 = 3.344	4 = 1.352	4 = 4.2267	4 = 1.05668
5 = 32.257	5 = 0.46452	5 = 4.181	5 = 1.691	5 = 5.2834	5 = 1.32085
6 = 38.709	6 = 0.55742	6 = 5.017	6 = 2.029	6 = 6.3401	6 = 1.58502
7 = 45.160	7 = 0.65032	7 = 5.853	7 = 2.368	7 = 7.3968	7 = 1.84919
8 = 51.612	8 = 0.74323	8 = 6.689	8 = 2.706	8 = 8.4534	8 = 2.11336
9 = 58.063	9 = 0.83613	9 = 7.525	9 = 3.043	9 = 9.5101	9 = 2.37753

DRY MEASURE		LIQUID MEASURE		
Hectoliters = Bushels	Bushels = Hectoliters	Fluid Ounces = Centiliters	Quarts = Liters	Gallons = Liters
1 = 2.8375	1 = 0.35242	1 = 2.957	1 = 0.94636	1 = 3.78544
2 = 5.6750	2 = 0.70485	2 = 5.915	2 = 1.89272	2 = 7.57088
3 = 8.5125	3 = 1.05727	3 = 8.872	3 = 2.83908	3 = 11.35632
4 = 11.3500	4 = 1.40969	4 = 11.830	4 = 3.78544	4 = 15.14176
5 = 14.1875	5 = 1.76211	5 = 14.787	5 = 4.73180	5 = 18.92720
6 = 17.0250	6 = 2.11454	6 = 17.744	6 = 5.67816	6 = 22.71264
7 = 19.8625	7 = 2.46696	7 = 20.702	7 = 6.62452	7 = 26.49808
8 = 22.7000	8 = 2.81938	8 = 23.659	8 = 7.57088	8 = 30.28352
9 = 25.5375	9 = 3.17181	9 = 26.616	9 = 8.51724	9 = 34.06896

(WEIGHT AVOIRDUPOIS)

Centigrams= Grains	Kilograms= Ounces Avoirdupois	Kilograms= Pounds Avoirdupois	Metric Tons=Long Tons
1=0.1543	1=35.274	1=2.20462	1=0.9842
2=0.3086	2=70.548	2=4.40924	2=1.9684
3=0.4630	3=105.822	3=6.61386	3=2.9526
4=0.6173	4=141.096	4=8.81849	4=3.9368
5=0.7716	5=176.370	5=11.02311	5=4.9210
6=0.9259	6=211.644	6=13.22773	6=5.9052
7=1.0803	7=246.918	7=15.43235	7=6.8894
8=1.2346	8=282.192	8=17.63697	8=7.8736
9=1.3889	9=317.466	9=19.84159	9=8.8578

Grains=Centi- grams	Ounces Avoirdupois= Grams	Pounds Avoirdupois= Kilograms	Long Tons=Metric Tons
1=6.4799	1=28.3495	1=0.45359	1=1.0161
2=12.9598	2=56.6991	2=0.90919	2=2.0321
3=19.4397	3=85.0486	3=1.36078	3=3.0482
4=25.9196	4=113.3981	4=1.81437	4=4.0642
5=32.3995	5=141.7476	5=2.26796	5=5.0803
6=38.8793	6=170.0972	6=2.72156	6=6.0963
7=45.3592	7=198.4467	7=3.17515	7=7.1124
8=51.8391	8=226.7962	8=3.62874	8=8.1284
9=58.3190	9=255.1457	9=4.08233	9=9.1445

INDEX

	PAGE
Abnormal milk	65
Acid, butyric, capric, caprylic, myristic, oleic, palmitic, stearic.	16
carbonic, hydrochloric, phosphoric, sulphuric..	20
citric.	22
lactic...	19
salicylic..	127
sulphuric	98
tests.....	94, 222, 223
Acidity of milk.....	94
of ripened cream in relation to richness of cream...	221, 224
of starters.	237
tests for...	222, 223
Adhesion of milk...	37
Albumen in milk.	18
Albuminoids in milk...	16
Alkali of various strengths for measuring acid in milk and cream.	94, 221
American Association Test for buttermilk and skim-milk	103
Amphoteric reaction of milk..	33
Antiseptics.....	50
Ash in Milk.....	19
Babcock test for fat.....	97
causes and remedies for common defects in clearness of fat	
in..	100
Bacteria in milk, aroma and flavor producing.	215
as a cause of deterioration of butter.	13
classification of.....	61
conditions favoring development of	55
desirable and undesirable in cream ripening.	217
kinds of germs found in milk.	60
number of, in milk.	62
size and shape of	55
sources of.....	62
unfavorable conditions for	58
Belt, pulley and speed calculation.	385
Boiler, cleaning of..	384
priming of....	384
firing.....	381
wood or coal for.....	382

Breeds, composition of milk from various.....	75
Brine, salting butter with.....	287
soaking tubs in.....	300
Butter, appearance or style of.....	342
classification and grades of, as outlined by N. Y. and Chicago Mercan- tile Exchanges.....	342, 347
color of.....	253, 341
composition of.....	309
cost of manufacturing.....	297
exportation of.....	350
flavor of.....	341
for storage.....	357, 360
judging and grading of.....	340
keeping in creameries.....	296
making of, on farm.....	180
mottled, causes and remedy.....	279
package, style of.....	294
packing of.....	294
preparing for market.....	294
printing of.....	299
saltiness of.....	342
storing in creameries.....	296
tests for fat in.....	107
texture or body of.....	341
treatment of.....	300
washing, and kind of wash-water.....	263, 265
working of.....	291, 360
Butter-making, History of.....	1
Buttermilk, test of.....	101, 103
removal of.....	263
Butyrin	13
Calculation of amount of salt to add to butter.....	272
average per cent fat.....	131
churn yield.....	135
cream-raising coefficient.....	140
dividends.....	137
overrun.....	133
solids in milk.....	35
Cans, starter.....	238
washing of.....	125
Care of cream on farm.....	176
Casein in milk, condition of.....	17
Centrifugal separation of cream.....	154
Churn, keeping in good condition.....	260
Churn yield, calculation of.....	135
Churned milk, sampling.....	122

	PAGE
Churning, amount for a.....	247
color.....	253
conditions affecting.....	240
definition of.....	230
degree of ripeness.....	248
difficult, causes and remedy for.....	258
mixed, sweet, and sour cream.....	258
nature of agitation for....	240
richness of cream for..	245
size of globules....	252
straining of cream previous to.....	253
temperature....	240
when to stop.....	255
Citric acid in milk.....	22
Cold storage.....	352
benefits of.....	353
cost of.....	355
history of.....	352
mechanical refrigeration.....	353, 363, 375
Cold storage butter, should it be branded..	356
Color, butter.....	253, 341
Coloring matter in milk..	22, 32
Commercial starters.....	227
preparation and use of.....	230
Composite samples.....	127
arrangement and care of.....	128, 129
preservatives for.....	127
sampling apparatus for.....	122
Composition, of butter.....	300
acts and rulings as to.....	309
analysis thirty years ago.....	315
of colostrum milk.....	65
compounds for increasing yield.....	310
control of moisture.....	312
of dairy salts.....	278
different kinds of milk.....	5
need for regulations.....	311
of salty milk.....	66
separator slime.....	166
tuberculous milk.....	73
Continuous method of pasteurization.....	208
"Cooley" method of cream separation.....	150
Cooling facilities, for creameries.....	362
cooling systems.....	362
mechanical refrigeration.....	353, 363, 375
natural ice.....	363

	PAGE
Cows, breeds of	75
Cream, acidity of, for churning	224
care of, on farm	176
effect of cleanliness on quality of	176
grading of	93
methods of disposing of	179
neutralization of	184
pasteurization of	201
sour	189
ripening of	215
sampling of	118
Creamery sewage disposal	299, 300
Curdy specks in butter	285
Deep-setting system of cream separation	150
Defects found in butter	323
advance in lactation	329
cheesy flavor	324
faulty factory conditions	325
feed flavors	327
fishy	336
flat or insipid flavor	323
flavors by absorption	324
garlic	327
metallic flavor	335
sour flavor	325
stable flavors	324
tallowy flavor	332
Difficult churning, causes and remedy	258
Dilution, effect of, on creaming	153
Disinfectants	59
Electricity, effect of, on germs in milk	64
Enzymes in milk	22, 54
classification	54
effect of heat on	41
tests for	42, 201
Export butter	350
Farrington test	223
Fat, in butter	309
milk	8
composition of	15
condition of	11
effects of environment	80
heat on	42
various feeds on composition of	242

	PAGE
Fat, in milk glycerides of	10
glycerine in	15
melting-point of	10, 14
membrane enveloping fat globules	11
microscopical appearance of	9
non volatile	14
paying for, as compared with fat in cream	143
properties of	10
separation of	149
size of globules	8
testing for	98, 99, 103, 107
volatile	13
Feeds, effects on milk	79
Fermentations, detection of	67, 94
various kinds of	67, 71, 73
Ferments in milk, classification of enzymes	54
favorable and unfavorable conditions for	55, 58
Fibrin	22
Filtration of water	266
methods and effects of	266, 269, 270
Flavors of butter	323
milk	20, 32, 40
Food for bacteria	55
Formula for calculating churn yield	135
cream-raising coefficient	140
dividends	137
overrun	133
solids in milk	35
Frozen milk, effects of freezing	123
Galactase in milk	22
Garlic, removal of flavor	327
eradication of	328
Gases in milk, eliminating	21
kinds and sources of	20
Gerber fermentation test	95
Glassware for Babcock test	99
Grading milk and cream	92
Gravity separation, different systems of	35, 49
Gritty butter	278
Heat, effects of, on properties of milk	38, 96
Heating milk previous to skimming	145
Hydraulic method of separation	153
Hydrogen peroxide	202

	PAGE
Ice, for cooling cream	374
refrigeration	365
Injector	385
Judging and grading butter	340
classification	342
Chicago	347
New York	342
export butter	350
manner of judging	341
standard for	340
Keeping property of butter	188, 360
effect of salt on	273
Lactation period, effect of, on milk and fat	78
Lactochrome in milk	22
Lactometer, comparison of scales on	35
use of	33, 97
Lecithin in milk	22
Lime, its use in creameries	261
Mammary gland, description of	23
inflammation of	30
Mann's test	222
Mechanical refrigeration	353, 363, 375
Membrane enveloping fat globules	11
Mercantile Exchange, New York and Chicago grades of butter	342, 347
Metric system of weights and measures	388
Milk, abnormal	65
apportioning skimmed	124
bitter	60
bloody	67
blue and yellow	68
classification of	3
colostrum	65
composition	4
of, from different animals	5
definition of	3
effects of thunder-storms on souring of	64
fat in skimmed	150
fever	30
from barren and spayed cows	72
from cows a long time in milk	71
grading of	92
necessity of good	117
properties of, physical and chemical	32

	PAGE
Milk,ropy	68
salty.	66
sampling of	118
frozen, cl uried, and sour.	122, 123
secretion of, conditions affecting	28
theories.	26
from sick cows.	72
specific gravity of	33
specific heat of	38
variation in quality of, and causes	74
water of.	6
Milk and its products as foods.	43
biological classification.	45
ash	46
proteins.	46
unidentified substance	47
in milk fat.	47
chemical classification.	44
Milking, frequency of.	75
manner of.	76
Moisture control.	312
factors that aid in	318
tests of butter	203
Mold, in butter.	304
on butter.	306
conditions favorable to growth.	307
discolorations	307
propagation.	307
sources of.	307
Mottles, causes of, in butter.	279
kinds of	281
prevention of	284
Natural starters, preparation of.	226
Neutralization, "neutralization" of cream	183
neutralization of cream for butter-making	184
neutralization, principle of.	183
other neutralizers.	199
pints of lime mixture required to reduce acidity to .25 per cent (Table).	196
the preparation and use of lime as a neutralizer.	102
Non-volatile fats	14
Nuclein in milk	22
Oil separator.	385
Olein, effect of variation of, on softness of butter.	14
Opacity of milk.	32

	PAGE
Overrun, definition and calculation of	133
factors governing	133
what should it be	135
Packing butter	294, 360
kind and style of package	294
for storage	360
treatment of tubs previous to	300
Palmitin	14, 15
Paraffining of tubs	302
Parchment paper, treatment of	304
Pasteurization, advantages of	201, 214
cost of	212
definition	201
disadvantages of	214
good milk and cream important	204
methods of	208
sanitation	206
Storch Test for	201
temperatures	202
Pasteurizers, durability and efficiency	210
Paying for fat in cream as compared with fat in milk	143
Proteids in milk, as a cause of mottles in butter	280
kinds of	16
Quevenne lactometer	34
Receiving milk and cream	92
Richness of cream from centrifugal separator	81
gravity separation	151
Ripening cream, definition	215
degree of acidity to ripen to	224, 248
kinds of acids produced from	215, 217, 220
mixing starter with cream	221
objects of	215
temperature	220
tests for acidity	221
Salt, as a cause of mottles	270
composition of American and Danish	278
condition of, when added to butter	277
effect of, on keeping property of butter	273
removal of buttermilk	275
in relation to water in butter	275
kind and condition of	277
undissolved, in butter	278
Salt test, chemical changes	288
features of	289

	PAGE
Salt test, principle of	258
to make	260
Salting butter, amounts of salt to use	272
effects of, on keeping property of butter	273
purpose of	272
with brine	287
Samples, average	130
composite	127
Sampling-tube	120
Score-card for butter	340
Sediment test	116
Separation, advantages of centrifugal	155
centrifugal	154
classification of centrifugal machines	158
conditions affecting completeness of	161
effect of speed as compared with diameter on	164
factors governing richness of cream	81
gravity	35 149
heating milk for	145
history and development of	155
process of centrifugal	158
Separators, farm, introduction and development	168
objections to	171
power for	174
reasons for introducing	168
thickness of cream	172
Separator slime, composition of	165
Sewage-disposal plants, cuts of	209, 300
Shallow pan creaming	149
Skimmed milk, apportioning	124
Standards, legal, for butter	317
dairy products	387
Starter cans	238
Starters, amount to use	221, 237
commercial	227
definition, history, and classification	225, 226
inoculation	232
length of time to carry	236
milk powders for	235
natural	226
poor	236
preparation of	226, 230
Statements, annual	141
patrons' monthly	141
Sterilization	203
Storch test	201
Streaked butter	281
Sugar in milk	18

	PAGE
Table showing effect of temperature on growth of bacteria	56, 57
fat and total solids of milk from various breeds.	76
Taints in milk, eliminating	21, 40
sources of.	20
Temperature, churning.	240
duration of.	245
effect of, on bacterial growth.	56, 57
for storing butter.	296
pasteurization.	202
ripening.	220
separation.	145
wash-water.	263
Tests, acid.	94, 221
fat.	97
in butter.	107
buttermilk and skim-milk.	101
cream.	99
milk.	98
Tests, fermentation.	94
pasteurized milk.	201
Total solids in milk, variation of.	5
Tubs and boxes, paraffining of.	302
styles of.	294
treatment of.	300
Udder, external appearance of.	30
internal structure of.	23
Urea in milk.	22
Utensils, cleaning.	125, 166
Variation of fat in cream, causes of.	81
amount of water or skim milk used to flush the bowl	90
cream screw adjustn. et. c.	82
rate of inflow.	85
richness of milk.	83
speed of machine.	87
temperature of milk.	88
Variation of fat in milk, causes of.	74
advance in lactation.	78
age of cow.	78
breed of cows.	75
condition of cow.	80
environment.	80
feed of cows.	79
fore and after milk.	77
individuality of cows.	74
manner of milking.	76
time between milkings.	75

	PAGE
Viscogen, use of.....	39
Viscosity of milk.....	37, 39
restoration of.....	39
Vitamines.....	47
Volatile fats.....	13
Washing butter, kind of wash-water for.....	265
purpose of.....	263
Washing cans.....	125
Water in butter, condition of.....	257
control of.....	312
Water, filtration.....	266
in relation to salt in butter.....	275
methods of purifying.....	266
pasteurization.....	266
Wisconsin curd test.....	95
Working of butter, for storage.....	360
objects and effects of.....	291

