

How I made  
\$10,000  
in one year  
with 4200 Hens

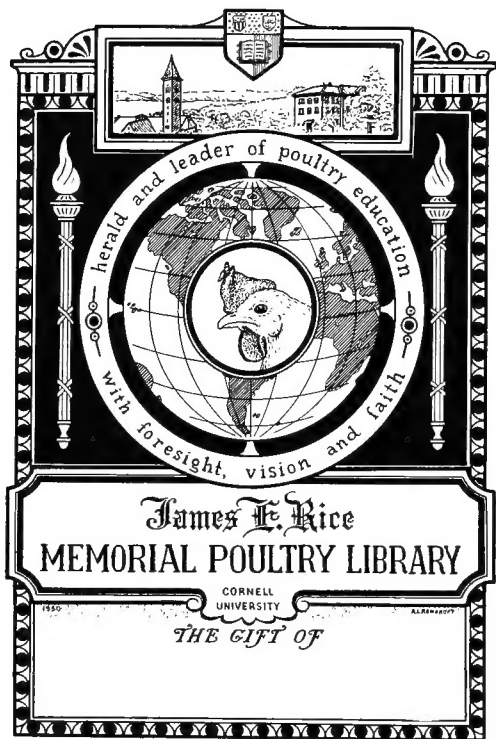

ALBERT R. MANN LIBRARY

NEW YORK STATE COLLEGES  
OF  
AGRICULTURE AND HOME ECONOMICS

AT  
CORNELL UNIVERSITY

Cornell University Library

SF 487.T92

How I made \$10,000 in one year with 4200



3 1924 003 133 901

mann

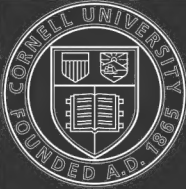

# Cornell University Library

The original of this book is in  
the Cornell University Library.

There are no known copyright restrictions in  
the United States on the use of the text.



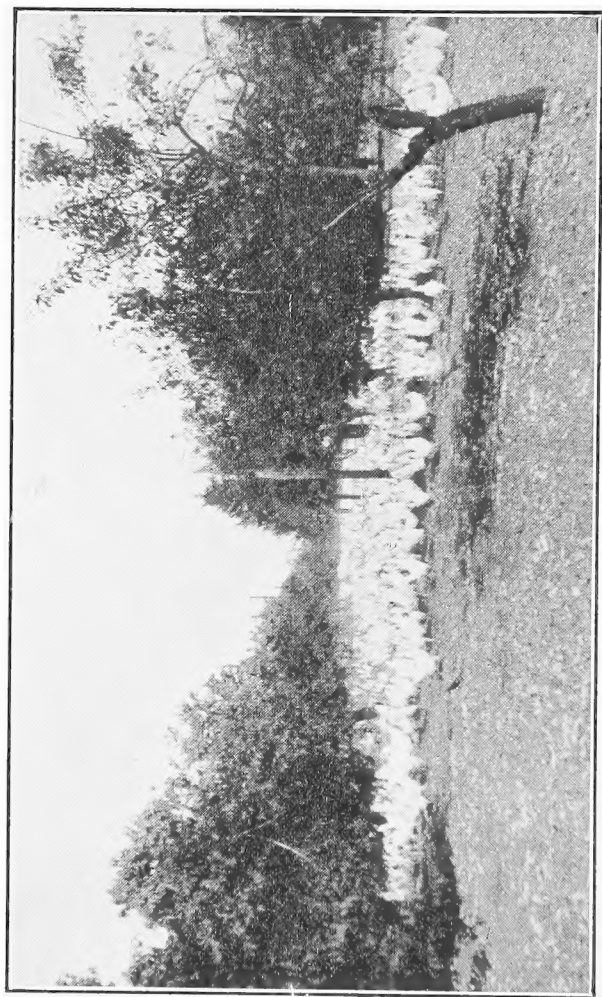

LOOKING OVER A FLOCK OF 3000 WHITE LEGHORN HENS ON THE TUMBACH EGG FARM

How I Made \$10,000  
in One Year With  
4200 Hens

BY  
JOSEPH H. TUMBACH

SF  
487  
T92

**E 7858**

Copyright, 1919  
By JOSEPH H. TUMBACH  
All rights reserved



## INTRODUCTION

---

This work is written for and is offered especially to those who are interested in or who contemplate engaging in commercial egg-farming for the profit to be derived from the operation. The writer frankly proclaims that he knows nothing whatever about the science or art of poultry breeding, and excepting for appreciating a beautiful bird he would not know a standard bred bird from an ordinary one. His right to offer this work is based solely on the fact that he has "made good" in the work from a financial standpoint. His "biddies" have to their credit at this time a profit above their cost of keep in excess of forty thousand dollars. The profit in 1918 was out of proportion to previous years. This was due in a large measure to the fact that when the "poultry panic" set in in 1917 and many operators quit, discouraged at the outlook, the writer practically doubled his flock; and the greatest increase was made in young pullets.

This is not a theoretical exposition. The writer has been in the work more than eight years and he is now engaged in it. He has raised and is raising not a few, but thousands of chicks each year; he has kept and is keeping thousands of hens. Fully 90 per cent of his working hours for more than eight years have been spent working among and with the birds. He has been through every stage of the work, from cleaning a hen house to building several that measure 16x150 feet; from selling a dozen eggs at retail to contracting a year's output of more than a million and a quarter. He has candled and put eggs into storage; he has hatched chicks by

the hen method and in incubators; brooded them in fireless hovers in lots of 50 and by the stove method with more than two thousand in one lot and house. He has fought mites, lice and ticks; he has been through sieges of colds, swell-head, chicken-pox and canker—not with a mere handful of birds but with thousands of them, and there is a vast difference in the operation.

The advice and recommendations he makes herein are based on that experience, and the methods herein outlined are the methods he follows. Let it be understood that these plans and methods are by no means given out as the ONLY way to success. They are given simply as the plan and method by which he netted \$10,000 in 1918 from an average of 4200 hens, and by which he has persistently, year after year for more than six years, made a very handsome profit from the keeping of hens for commercial egg production. With other methods and systems he is not herein concerned and he who seeks argument on comparison of plans and methods must look elsewhere.

To the writer it seems that the great error in most books on poultry work lies in their failure to point out some definite, concrete plan on which to proceed. To a man totally ignorant of the practical side of the thing it is simply confusing to outline many plans of procedure, of which he may take his choice. It seems more reasonable to outline the definite plan and method by which a success has been achieved and let him follow that if he will, until, from his own experience, he is qualified to make the deviations and improvements which will lend themselves more readily to his particular case.

For the benefit of those who are fearful of their lack

of experience with poultry or with any form of farm life it may be noted that the writer was city born and bred, an accountant by profession, and that when he started he hardly knew a hen from a duck.

Should the reader by chance be a poultryman of experience his indulgence is craved for much to be found herein that will to him seem simple, even laughable. He is asked to remember that such things are addressed primarily to him or to her who knows as little about the birds and the work as the writer did when he started. A special effort is made to save the inexperienced, as far as may be possible, the anxieties and extreme discomforts suffered by the writer during his first few years in the work, and to make plain and comparatively easy the many little points, simple in themselves, which to the beginner seem veritable mountains of trouble.

But the writer makes bold to suggest also that even the experienced may find matters herein well worthy of thought and consideration. The problems concerning the industry are in many respects far from being solved, and unless those who operate on comparatively a large scale adopt a more liberal—it might even be said a franker attitude than is now commonly encountered—such problems may never find a solution. This is to be regretted, especially so since it involves a financial loss not only to the individual operator but to the industry as a whole.

Many points covered herein have their promptings from calls we have had for advice and counsel either from beginners or from others in the work who encounter some especial difficulty. These calls become more numerous every day and this work, unselfish in its prompting, may lighten the burden by affording an easy means of answering such calls for help.

In conclusion the writer gives it as his opinion that anyone who is willing to work, who is willing to stay at home 365 days in the year, from early morning until late at night, for the first few years at least, **who loves birds or animals**—any one who has these qualifications—can, if he will, do as well or better than he has done.

JOSEPH H. TUMBACH.

Pasadena, Calif.

## PART ONE

A discussion from the standpoint of one who wishes to enter the work of egg-farming, who is not yet located and has not bought property, but who wishes to buy land at the start.

---

### Location

The important consideration in locating an egg farm is the matter of market. If you follow in the writer's footsteps your main objective in life is the production of eggs for table use. Time is your greatest enemy because it works against your product the moment the egg is laid. Your problem then is to put that egg on the market in the shortest possible time. For this reason, if you have the choice, locate your egg farm as close as you can to a good all-the-year-round market. Don't go out on the desert because land is cheap there. And don't think a location is first class because it is close to a summer or winter resort where people flock during a part of the year. You will have eggs to sell 12 months in the year and you want a 12-month market.

Your plant should be within reasonable trucking or shipping distance of some large marketing center where eggs are handled in large quantities. If poultry plants are being conducted in the section where you think of locating or starting, ask the people running such plants about the market facilities. If you intend starting in a new section, consider its location with reference to the primary marketing point—in California, for instance, San Francisco and Los Angeles are the two primary marketing points. If no poultry people are available for the

information go into these cities, find the produce marketing centers, consult with egg dealers, (you can find them in the city directories if in no other way), and learn from them how they would treat you in the matter of buying your product. If you find a better market than they offer you well and good; but make certain before you start that there will be a ready market for eggs produced in the section you have in mind.

Locating in a section where there are other egg and poultry farms has many advantages. Where a considerable number of such farms are operated there is usually an arrangement by some egg buyer for regular trips by trucks to pick up the eggs and return empty cases. This is a big advantage. If you are entirely new to the work you will feel much more comfortable at it if there is someone within hailing distance should you get into serious doubt or trouble over any phase of the work.

Be sure you are not following some real estate boom, though. The country is full of poultry-wrecks, the result of some real estate boomer advertising a tract of land as a poultry colony regardless of its fitness for such work. If your choice is some place where you can find a plant that has been in operation for years and that is not all run down at the heels and ready for the junk man, all the better. This would indicate that somebody made a go of chickens in that locality and if he did it you can.

Your nearness to market means also that you will be close to feed and supplies—and the closer you are to a district where grain and feed is grown, the cheaper will be your feed bills.

Avoid, if you can, locating your plant very close to a

railroad. You will be raising baby chicks and carrying young pullets and laying hens. The sudden shrieking of locomotive whistles, clanging of bells and grinding of wheels will be a most harmful influence at all stages.

Before locating your plant within the limits of a city or town, make sure there are no restrictions against chickens in large flocks, or that the chickens must not be kept a certain distance from an adjoining residence. Secure information on these points from the city or town officials—don't go on the opinion of the man from whom you would buy.

Generally speaking, it is unwise to locate an egg farm within the limits of a city. The neighbors may not object to one or two crowing roosters and cackling hens but it may seem different to them if one hundred roosters and several thousand hens provide the concert. Furthermore, ground for complaint is easily found when even a single animal is kept in a city, let alone thousands of hens.

If, in seeking a location, you should encounter the remains of old poultry plants, try and learn the cause of their failure. The soil may be too heavy, making it subject to standing pools of water and sticky mud; there may be sand fleas or ticks if it is very sandy; it may be too windy or stormy for hens to do well; it may be subject to heavy fogs especially in the spring when the young stock is raised; it may be the land lies in a draw or depression where there is a heavy suction of air at night; there may be a scant water supply. On the other hand, if none of these disadvantages are apparent, the people who tried there may have been at fault themselves; if so,

you might do well to buy some of the remains at a bargain and save a lot of money. More will be said on the latter score under "Buildings."

### Soil

The ideal chicken soil is a light, sandy loam with a gentle slope to the south. This means perfect drainage away from your buildings. Where we are located it is unusual to find even a small pool of standing water 30 minutes after the heaviest rain storm. This is almost ideal.

Nor is drainage the only consideration. A light, loose soil lends itself much more readily to cultivation, it is an easy matter to keep the ground fresh, and the hens have an incentive to keep busy scratching. During the rainy season, such as we have in Southern California, the top soil is washed clean, the impurities sinking into lower levels. Such a soil requires far more water and fertilization for the growing of green stuff, but the advantages offset this tenfold.

It is not impossible to successfully operate an egg farm on heavy soil. Our plant was located on a stiff "dobe" soil the first five years, where a crowbar had to be used to dig a post hole during the summer months, and where a sticky mud formed during the rainy season, and we laid the foundation for our success on that place, making good money at it after the first two years. We had only one attack of serious trouble during the five years, and as other people located on lighter soils had the same trouble at the same time, it seems reasonable to assume that the soil was not the cause of it. But heavy soil makes the work far more difficult and is much



less pleasant for the hens ; so avoid the heavy soil if you can.

### Buildings and Yards

There is no ideal building for housing either chicks or hens—one that can be used in every country and every climate. Local weather conditions make modifications necessary wherever you may go. The writer has seen hens kept, on an egg-farming basis, in little houses without yards, the likes of which if attempted in a southern climate where it really gets hot, would result in cooking the life out of the birds, and the other extreme was a case where no houses were used at any season of the year. If this were attempted in Maine or in Michigan, especially with Leghorns, the birds might not actually freeze to death but they would surely lose their combs and wattles and they would lay few if any eggs in the winter.

Before deciding on the style of housing you will adopt, make inquiries and learn who is most successful in the district. There is always someone who stands out above the rest in making a success of the work. Learn from him or them how your brooder houses and laying houses had best be faced. Generally speaking a southern exposure is best, east is second choice, west third, and north last or not at all. The writer cannot recall seeing a successful poultry plant with houses faced north. There are some, of course, but they are rare. Unless your successful man is a faddist whose ideas are contrary to all generally accepted rules for keeping hens you might well follow his lead both as to exposure and as to style or type of housing.

But if you find a number of successfully conducted plants in the section, operating with practically the same style and type, you are safer in following that lead than in following the one. For instance, in Southern California by far the greater number of poultrymen use the long, partially open-front laying house. Were you locating in this section your best plan would be to adopt that style. Of course you might come here and show us something new, something that would put our efforts in the shade, so to speak. But be sure you have enough money with you to enable you to tear down and rebuild should your innovation prove a failure. An experienced poultryman could go into almost any poultry section and make improvements on the housing and methods commonly employed, but a beginner usually lays out for himself a hard row to hoe when he attempts to learn the business and to start an innovation at one and the same time. The writer knows this to his cost—that is why his first two years resulted in failure. The hens were not a failure—they did remarkably well and showed a fine profit, but he could not get enough hens to make the total profit pay his living expenses, let alone a surplus for rainy days.

This suggests another “don’t”—don’t be misled by reports you see giving the results of a certain system or method **where a few hens were used to make the test.** If you make a success of the work you will want at least one thousand and if you are ambitious, even moderately so, two thousand will be the least number you will carry. And it is absolutely foolhardy to base your ideas of the business and its returns on multiplying by one or two thousand the results per hen you can find in many reports of experiments.

Another point worth making: If you are buying a place on which there are some old buildings (chicken houses or any other kind) and if your capital is limited or you wish to determine whether or not the work suits you, you can easily adapt them for use for a year or two. The writer made a perfectly satisfactory brooder house out of two old sheds, 7x12 feet, 6 feet high in front and 4 feet in the rear, by tearing out the fronts of both and placing them nose to nose, making one building 12x14. There were several such sheds on the place. Two more were set twelve feet apart, the intervening space was roofed over, the back was connected up, resulting in one building 7x36; a "porch" 5 feet wide was run along the front (which was left wide open), sloping away from the main house, which kept out the rain and wind and the whole resulted in a very comfortable house 12x36 feet in which 350 hens were kept. A little ingenuity, or a day's wages to some good carpenter, might easily save you a lot of money at the start.

Sand-papered and varnish finish are not a necessary adjunct to success. What you need primarily is a house in which you can absolutely control the inflow and outgo of air and which will keep out storms and rain. The detailed description of our buildings may serve as a useful guide as to the necessary features even though you do not adopt the plans as a whole. It is for this reason they are given, not with the idea that we have the only proper scheme of housing.

Should you use or adapt old buildings one thing in particular you **must** do—they must be most thoroughly disinfected. This is best accomplished by spraying with

the mixture we use, described in the chapter devoted to "Cleaning and Disinfecting." Cover every inch of that old building with this spray, inside and out, up and down and sidewise, and when you are through and have done a good job of it, **go over it again.** Five days later repeat the dose, and then you can feel that you have taken every human precaution against falling heir to trouble. It matters not whether there ever was a chicken within 10 miles of the place, or if there has been nothing in the building for as many years, spray it as herein outlined.

The question of yards and yard space is a much mooted one. Some people advocate shutting the birds into a house or coop and giving them no yard space at all because yards are disease breeders. This seems to the writer to follow literally the biblical injunction "if thine eye offend thee, pluck it out." We use yards and believe they are conducive to the health, well-being and happiness of the birds and we enjoy their seeming enjoyment of that much freedom.

Wallowing in loose moist earth seems to be one of the habits we cannot break biddie of, and there is grave question if we could afford to do it were she willing. There is this to be said, however—she is better off with no yard at all than to be on soil baked as hard as a brick and dry as a bone in summer and a mess of sticky mud in winter.

Ninety-nine out of 100 poultrymen, including so far as we know, all the experiment stations, give their hens more or less yard space and your safest course is to follow this lead. You should allow enough space to each house so that you can shut off a part of the yard at regular intervals and freshen the ground by growing something on it.

As to the size of the yard, no set rule can be given. If you were building a house 50 feet long, in which you will keep 500 hens, your best plan would be to have one yard in front of the house and one in back. On this plan if each yard were 30 feet deep and the length of the house, 50 feet, the hens would do nicely on it if the soil was reasonably loose and open. If it suited the shape of your land better, you might have a yard the length of the house and say 100 feet deep, divided in the center. Then again you might have the 30x50 yard in front of the house and one of the same size at either end. You will see later how our yards are arranged.

### Planning the Plant

In selecting your land, avoid a hilly, steeply sloping location if you can. You can lay out a plant on anything short of straight up and down but it is a much harder problem and the assistance of an expert, practical poultryman is almost necessary to do it successfully. A long, narrow tract is harder to lay out than one oblong or nearly square. If long enough and narrow enough you will walk yourself to death unless you install a tram car or use a motor car.

The number of hens that can be kept on a given space is a question involving many problems and one that is asked us almost as frequently as "what do you feed your hens?" In attempting to answer it we must first of all agree that we will give the hens yards; the writer cannot hazard an opinion otherwise as he does not favor the no-yard idea. On this basis it is reasonable to count on 1000 hens to the acre with a minimum of 5 acres, or

about 800 to the acre with a minimum of  $2\frac{1}{2}$  or 3 acres. There are many successful poultry plants in operation where this limit is exceeded, and it can be exceeded where the soil is especially good or where it is planned to break the operation every few years, sell off all the birds and take a vacation for a year while the whole system of yards is freshened by growing crops. This is the best answer that can be given to the question.

When you have agreed on a deal for your land your first move should be to have it surveyed by a licensed surveyor. This is an ordinary business precaution. You ought to know that the land you are looking at is the land your deed will convey to you. Then have the surveyor make a plat of it for you on a fairly large scale. This you can use in making diagrams of the settings of your various buildings and yards. Make a drawing of the buildings and yards in different positions. If you do this you will be able to lay out the plant to much better advantage than would be the case if you go at it in a random sort of fashion, and your place will look all the better for it. Then take a tape line and a lot of stakes and stake the plant on the ground as you have drawn it on your plat. Walk around from building to building as it would be; consider the idea of having to go over the place in your daily rounds, the distance you would have to carry the feed stuffs and eggs. A proper arrangement of your plant at the start will save you many steps and a lot of time.

Consider the drainage problem—you don't want the door of a building right in line with a possible flood during the season of heavy rains; you want a high wall at

that point. Mark it if you see a chance of this occurring so that your builder will give you a high wall there. Don't set your feed house in a depression if you can help it; if you can't avoid it, be sure you have high concrete walls all around, and have the cement man plaster the concrete with top dressing after it has set. This will make it waterproof; ordinary concrete is not.

If your land slopes heavily you must bear in mind that your hens, and your chicks also, will help it in its sloping movement; most of their lives when they are outdoors will be spent in helping your land on its natural downhill movement. The floor of your house on the downhill side should be level with the ground if you are on a modest slope; on a heavy slope you can better afford to grade the building site so as to have a level space of 5 or 6 feet in front of the building, even though this means a very high wall in back to turn the rain-flow. The back walls on some of our laying houses reach to within a foot of the dropping-boards. There is no disadvantage in this.

If you can spare the space, leave a passageway of say 10 feet between the outer lines of your property and your chicken yards and houses. This means double fences but it also means that you have a margin of safety for birds flying the fences of their yards and a margin of safety also against prowling animals—both four-and-two-legged. If your neighbor keeps hens there is less danger of the flocks becoming mixed and lice or sickness communicating. You can plant this passageway in green stuff or garden truck and it will not be wasted, although it will be a bit more troublesome to care for a long narrow strip of this kind. But it is well worth the effort.



BREEDING STOCK (MOULTING SEASON) ON THE TUMBACH EGG FARM



If your land is bare, by all means plan on setting out fruit or nut trees. The hens will fertilize them for you and you will be wetting down the yards to keep the ground moist and obviate dust colds, so they will need little if any irrigation. We have never had nut trees in our yards but are considering resetting our old trees with walnuts. We have had apricots, peaches and prunes in the yards and derived some revenue from them although the birds eat and destroy a lot of the fruit; of the three the prunes were harmed the least.

You must allow space for growing green stuff. In the description of our plant and methods you will find this matter treated at length and you can without doubt obtain ideas there that can be adapted for your own place. Some think we are wasteful of space, especially in our brooder yards, but we make good use in one way or another of almost all the space we have.

### **The Breed to Keep**

Under present prevailing conditions you have no choice in the matter of the breed of chickens to keep on an egg farm. It seems safe to say that at least 90 per cent of the hens on the commercial egg farms throughout the country are White Leghorns. This being true you can ill afford to keep anything else. When you are safely established you will have hatching eggs to sell. If there is a commercial hatchery in the section where you locate the chances are all in favor of their wanting nothing but Leghorn eggs; and with the kind of birds you will have, cared for as you will care for them, the hatchery will want your eggs.

Your chances of selling eggs of another breed are slight in comparison. One can work up a sale for eggs from other breeds, and it is often possible to get better prices for them than for the Leghorns, but we are planning for the surest end of the thing. Again, you may lean toward the American breeds, such as the Rhode Island Reds, or the good old Plymouth Rock. You cannot afford them. They lay brown eggs and brown eggs are discounted in price in the primary markets. If you have just a handful you can sell them to your neighbors or possibly to the corner groceryman at regular prices, but you cannot do that with the product of an egg farm. Other objections might be advanced but it is a waste of time to discuss the matter.

We have often been asked about the advantages of crossing breeds. The work of Prof. Dryden leaves no room for doubt as to the advantages that may be derived from a scientific crossing of breeds. But until you are well along toward a comfortable financial surplus, derived from your egg-farming activities (which means that you will have had a considerable and varied experience in handling chickens), you had better leave experiments in crossing breeds to the other fellow; and what has been said as to the sale of hatching eggs applies to the cross-breeding matter also.

### **Profits to Be Expected**

An unqualified estimate of probable profits to be derived from egg-farming cannot be made at the time this is written (August, 1919). If the prices of eggs and of poultry feed stuffs remain at the level that has prevailed

during the present calendar year (1919) a flock of well-bred and well-cared-for birds, **averaging not less than half and half of young pullets and yearling hens**, should net a profit of not less than \$2.50 per bird.

If prices recede to the pre-war level, when the wholesale price of eggs (to the producer) dropped as low as 20c during the storage months of March, April and May; and if the price of the feed stuffs also declines to the pre-war level, when good feed-wheat could be bought in large quantities at about \$1.75 per hundred (practically \$1.00 per bushel) and first class yellow corn could be had at \$2.00 per hundred (\$1.12 per bushel), (both prices being on basis of delivery in our barns in Southern California), under these conditions the net profit per bird with the same flock should be from \$1.25 to \$1.50. This is as good an estimate as anyone can make under the conditions prevailing.

The figures are based on the writer's own experience, and the yield per bird, which of course governs the results, is based on the average production he has been able to secure, to-wit: from 140 to 150 eggs per pullet and from 110 to 120 eggs from yearling hens. If you can better this production one year for another your profits will be increased.

The estimates are based on selling the product for table use, at market quotations, which is the only safe basis to count on. Sales of eggs for hatching purposes would increase the profit per hen because of the premium received over the market price; but as such sales are problematical, the careful man bases his calculation on the **assured** price and considers any premium derived as "velvet."

### When to Start

You may start either in the fall or in the spring. Fall-hatched chicks stand a good chance of being the offspring of good layers. They mature and come into laying quicker than the spring hatched, and the broiler cockerels usually bring better prices in the market. The disadvantage lies in the size of the eggs. Fall-hatched pullets lay a very small egg at the start and the eggs are under normal size for several months at least; this means a discount on price. September hatched birds will be laying in February and as this is the beginning of the flush-laying season and prices are always at the low ebb at that time, the very small eggs bring a very low price. These birds will go into a late moult, beginning usually in September, and in the year following their first moult they are more than likely to out-lay a spring hatched pullet. They will out-earn a spring hatched pullet in the first calendar year (January 1 to December 31) as their second moult will be late and they will be laying and earning money during July, August, September and October, when the spring-hatched bird is in its lowest laying period. Our experience with them indicates that one can well afford to carry a fall-hatched bird an extra season. If you have them hatched in September, 1919, they will be laying in February, 1920; moulting in October, November and December, 1920; laying heavily until November, 1921 and you can afford to carry them until September or October, 1922. All of this is conditioned on your treating them properly, of course.

The fall-hatched chicks will cost you more than those hatched in the spring whether you buy eggs for hatching, whether you use eggs from your own flock, or whether

you buy baby chicks, because eggs are higher in price at that time and for the further reason that not only will the fertility of the eggs be lower but the hatchability of the fertile eggs will also be lower. But this increased cost will be offset to a large extent, if not entirely, by the fact that the cockerels sold as broilers will bring a higher price, and the pullets will mature and be self-sustaining at an earlier date.

If you wish to start in the fall, September 15th to October 1st would be a good time to have your hatch come off.

By far the greater proportion of chicks are brought off in March and April. These are generally considered the ideal months. But if you will have several broods of chicks, and especially if this is your first experience, the writer recommends that you have one brood in the month of January, preferably about the middle of the month. This will give you some experience before you enter the heavier hatching season. The objection to January hatched chicks is the fact that they will moult the following summer and fall. You can count on reaching the low ebb of egg production from January hatched pullets in October and November, the season of highest prices. They will show an increase in eggs late in November; will gain fast in December, and by January will do as well or better than the spring-hatched birds that did not moult. And if you keep the accurate records you will be advised to keep you will find that in spite of their moult, your January hatched pullets have earned as much above the cost of feed on January 1st as your later hatched birds that did not moult. This is because they mature and become self-sustaining quicker than the later birds.

The same objection may be made to the January as to the fall-hatched—their first eggs will be very small; but the eggs gain in size faster than the fall-hatched, and in addition these first small eggs will come into the market at a better time, the time when the flush of the lay is over and when prices are beginning to advance. The cockerels from a January hatch are ideal for breeders. We use nothing else. The broiler cockerels come in at the very peak of the market—if they are properly handled.

Your heaviest broods of chicks should come off in March. If you have two lots, March 10th and March 25th, would be good dates. If you have but one, let it be the 15th. The pullets from this hatch will give you their first eggs in August. They will be nearly if not quite self-sustaining in September—by which is meant they will pay for their feed—and will show a profit in October. Some of the quicker-maturing ones will go through a light moult, but taking the flock as a whole the moult will not amount to much. Some years whole flocks of March pullets will go through a light moult in their first fall, but this is exceptional, due, usually, to extreme weather conditions. A mild spring and summer followed by an extremely hot spell early in September is likely to bring on a moult. Improper feeding or a sudden change of rations in August will do the same thing.

Some years April hatched chicks will do as well and even better than those hatched in March but we prefer the latter month. We can offer no encouragement to the idea of hatching chicks for commercial egg-farming in May, June, July or August.

Whenever you start, whether in the fall or in the

spring, be absolutely certain that at least the brooder house is ready a month ahead of time. You might just as well have it ready a month ahead as one day. This is more important if you are entirely new to the work. You must not be rushed and bothered when you have your first brood of chicks on your hands. You want all the time in the world. If you are of a nervous disposition you will realize the force of this advice about two hours after your first chicks are turned loose in your brooder house.

## PART TWO

The discussion enlarged, to include the idea of using a rented or leased place at the start.

---

### Capital Required

So far as the chickens themselves are concerned it is comparatively easy to tell you what capital you must have. You can safely count on needing 85c to mature a pullet—\$850 for one thousand—if you start at the time herein recommended. This is based on your selling the cockerels as broilers as soon as they are ready for market and applying the proceeds on your feed bills as you go along. It is based also on your starting with either hatching eggs or baby chicks of a good strain from some commercial breeder or from some hatchery that specializes on first-class chicks for egg-farming purposes. Such chicks would cost you under present conditions from approximately 20c in January to 12 or 13c in March or April and perhaps 16c in September. Under pre-war conditions they would have cost perhaps 15c, 10c and 12c for the same months.

If you go in for higher grade stock at the start, chicks from trap-nested flocks or from birds bred for show purposes as well as for utility, there is no telling what the chicks would cost you; any estimate made would be a mere guess. Let us say you pay 30c for the chicks in January. The writer's "guess" as to the cost of raising the pullets then would be \$1.10, an increase of 25c. The increase is seemingly out of proportion but it is due to the fact that the broiler cockerels from the higher priced



chicks bring you no more than those from the cheaper ones, and the pullet you raise must stand the extra cost of the cockerel you sell. Furthermore, the pullet raised must also stand the extra cost on the chicks that die off. This is the best estimate that can be given you for such a circumstance.

The entire estimate is based on your raising what would be considered a fair percentage of your chicks. You may do better and it is easily possible to do far worse; but you ought to do at least as well as this.

To carry the subject of capital required farther than this we must use a concrete illustration. Let us say, for instance, that you want to start on the basis of living expenses of \$1,000 to \$1,200 a year; that you want to keep enough hens to yield you that much. The safe and conservative thing to do is to base your estimates on the profits that were to be expected in pre-war times which, you will recall, we set down at from \$1.25 to \$1.50 per hen. We all hope never to get back to that level, of course. If we do not, then we will be better off than our illustrated basis; we will have more than our \$1,000 to \$1,200. Better that than to be disappointed. Let us say also that you are renting or will rent (or lease) the place to be used at the start. Let us say furthermore that you want to get started in March. Here then is what you must provide for:

You must take possession of the place early in January, say January 1st; this gives you time to clean up, put the brooder house in shape, plant the brooder yard (to freshen the ground), and to get some green stuff started.

Your pullets should be self-sustaining by October 1st and should give you enough surplus in October to pay your rent and living expenses. We must bridge the gap between January and October.

Say your rent is \$30.00 per month—you will need \$270.00 for rent from January to October.

You want from \$1,000 to \$1,200 per year to live on—for nine months this would be let us say \$900.

We have tried to be conservative thus far, let us continue on that plan and count on 1,000 pullets; for that number you should have \$850.00.

You will need some tools and appliances—\$50.00 properly spent will provide the things absolutely needed at the start.

This gives us a total requirement of \$2,070.

There may be some special requirements. You may have to spend some money re-arranging, rebuilding or renovating the buildings on the place. We cannot estimate this—you will have to do that for yourself or have a carpenter do it for you. You will need troughs and chick fountains, later you will need larger sizes of same for the developing birds, and finally of a size suitable for matured birds. We will count on \$80 for these items. This gives us a grand total then of \$2,150.

But we cannot quite afford to stop at this point. We are now on our feet; we have an income sufficient to take care of us but if we stop there we get into trouble. Perhaps half of the failures are due to that premature stop. We must bear in mind that these pullets—that began laying in August and laid heavily enough in October to pay not only their feed but our rent and living expenses

beside—will reach the end of their string, so to speak. When we get along to August and September, nearly a year later, our biddies will go back on us; they will be feeling the effects of the moult. And in October and November we are exceedingly likely to be face to face with the proposition of putting them on half rations, to stand off the landlord, and either to quit eating our own meals or else to stand off the butcher, the baker and candlestick maker.

We may have taken the best end of it in our estimates—quite likely we really have stored up a surplus; but we are being cautious about the thing and not counting on the best possible results. So we must prepare for this season of shortage. We do it by repeating what we did last March. We take on another lot of baby chicks, part of them perhaps in January, the balance in March. For this we need another \$850.00, and we should have it in sight before we get started.

This gives us then a grand total of about \$3,000. And this is the sum the writer would tell you you should have in sight if you want to go into the business on the basis outlined. You do not need it all at once; the last \$850 will not be needed until about a year after the start is made, and you may not need all of it at that, but you should know where it can be had if you do need it.

And now we come to the parting of the ways: Are you content to make just your living expenses and rent, or do you want to forge ahead?

If you are content to make your living and stop at that your best plan would be to sell off the first-raised pullets at the end of their first laying season, probably in Sep-

tember or October. Your second pullets will take their place. You can easily sell them as layers if you are in a poultry-keeping district and you should get at least \$1.00 each for them. In this way you will get back a large part if not all of the last \$850 you needed, the cost of the second year's pullets. You might think that at \$1.00 each you would get it all back and more, too, but you will have lost some of them—we all lose hens.

Another plan would be to raise six or seven hundred pullets the second year, reducing your needed capital by the difference, and carry over three or four hundred of the first pullets through a second laying season, selling the remainder. Notice particularly that you are advised to raise and carry more pullets on this plan than yearling hens. This is important. You must not lose sight, even for a moment, of the fact that you will be faced with three or four "lean" months in the fall of your second year when your first pullets are moulting, and you must cover those months by the earnings of newly-raised pullets. To do this you must have more new layers than old moulters. If you make the total flock 1,000 birds on this plan you are taking up what leeway you had between the probable earnings of 1,000 pullets and the \$1,000 to \$1,200 you thought you wanted to clear, and you will make less net money the second year than you did the first. You can help overcome this difference by mating the carry-over birds during your second spring and using your own eggs for hatching, also selling the surplus eggs for hatching purposes.

In this way you should clear as much the second year as the first—if you find the market for the surplus hatch-

ing eggs. Look into the possibility of doing this before deciding which course to pursue. The first course, (selling off the entire first flock), is the surest way.

If you want to forge ahead, carry over all of the first year's pullets that are worth keeping—you will learn later how we cull them,—mate them all and provide all of your own hatching eggs. Even though you do not find an assured market for your surplus hatching eggs, you will save enough on your own chicks to make it worth while to mate these birds.

Following this second plan you will have 1,000 pullets and perhaps 800 yearling hens the second year and then you are on a fair road to success and independence. You will need no more outside capital; you will make enough surplus profit to enable you to build up as large a flock as you may be ambitious enough to strive for and if you follow in the writer's footsteps you will soon be buying a place of your own and putting up the kind of a plant you have meantime come to dream of as the ideal plant for an egg farm.

### **Starting Small While Working Elsewhere**

The possibility of getting a start in the work while engaged in other work is a question concerning which we have had many inquiries. It is a pleasure to say this is entirely feasible and possible if **you have the right kind of a wife.**

The means and method can best be illustrated by the case of a man who was employed on our place. He left us to take a better paying job as gardener on a large estate. He lived on a city lot. Nearby was a vacant tract of several acres, which he rented or leased by the year. He built a brooder house on his own lot,

where it would be close at hand, large enough to brood 1,200 chicks. He had money enough to provide house-room for and to raise 500 pullets. We advised him to brood one lot in January and another in March, and to try for 500 pullets in each lot, with the idea of selling half of each lot when they were about three months old. It is quite as easy to brood 1,200 chicks as 600; the work and expense for fuel is no greater; and there is no trouble in disposing of three months' old pullets at a good price.

He followed this plan, and did so well with the January lot both as to the number he raised and the price he obtained for them that he was able to retain the March hatch entirely, giving him 750 pullets instead of the 500 he thought was the maximum he could finance. He did the heavy part of the work mornings and evenings, his wife caring for the chicks during the day. His laying houses, following ours in plan, he built in separate sections, each 16x16 feet. He is using the dirt floor. When he gets ready to move to a larger place of his own he can load these houses on low-slung moving trucks, set them where he wants them, fit them together, and he will have his long, continuous laying-house. He did all of his building work alone and unaided, putting in his time after he came home from his regular work. This is going after it strenuously, but it is the spirit that succeeds.

There has been considerable discussion in our home as to who deserves the greater credit for his success—the man or his wife. (She was caring for three young children at the time). I give the man the greater credit—he picked his wife. But this case shows what can be done by people of the right kind.

### How to Start.

The easiest way to get started, so far as the birds are concerned, would be to buy pullets nearly or quite matured. Many people base their plans on such a scheme.

From a basic standpoint the idea is wrong and if you expect to succeed you had better get rid of the notion at the very start. There is only one secret of success in the work—the handling and raising of baby chicks, and unless you learn to do this you will fail. This is because of the uncertainty of being able to buy pullets of the kind you must have, birds that were hatched at the right time, the offspring of the right kind of stock, and a sufficient number of them. There may be places where you can buy pullets to fill this bill, at prices you can afford to pay, but if so the writer is not aware of it. To put it still plainer, you must be able to place an order for say 1,000 pullets, hatched March 1st to 30th, out of the right kind of stock, at a price not to exceed \$1.50, for delivery about August 15th. At the price named you would be paying \$650.00 more for the birds than the estimate made as to the cost of raising them yourself.

You can buy pullets—and so-called pullets; and at times you can pick up a few, even a few dozen, here and there that are worth buying. People who raised them are moving away or have grown tired of putting money into them without returns, or sickness disrupts the plan that caused them to be raised. At times some would-be egg-farmer becomes disgusted or his money gives out, and you might pick up several hundred. Under such circumstances you can buy them for a dollar and even less. Again, you can buy them of dealers. In the

latter case the chances are ten to one that you are buying someone's culls, or what he thinks are culls; and there is an even chance that you are buying some early moulting hens, especially if you get them along in November or December.

All of this is entirely too haphazard for you may find, when October 1st arrives, that instead of replacing your old hens with 1,000 pullets you have instead 200 or 300 birds of more or less uncertain age and of still more uncertain pedigree, and your year is wasted, which means that you will have to look to other sources for your income and livelihood.

The writer has known of one or two instances where people have bought as many as several hundred very good pullets that he himself would have bought had the chance offered; and picking up a dozen birds that would make a wonderful showing is not unusual, but relying on such chances has no place in commercial egg-farming.

You must learn the trick of caring for baby chicks. Whether you start with hatching eggs or with baby chicks from some poultryman or from a commercial hatchery is immaterial so far as this phase of the matter is concerned. But if you do not care to undertake the drudgery and the close confinement involved in properly brooding and handling baby chicks you had better not enter commercial egg-farming.



## PART THREE

A description of The Tumbach Egg Farm from which ideas may be obtained as to the laying-out of a plant; and of the buildings used, from which ideas may be had as to buildings that have been proven practicable and conducive to success in Southern California.

---

### The Plant

The Tumbach Egg Farm is laid out on a 5-acre tract just outside the city limits of Pasadena and about 16 miles from the business center of Los Angeles. The location means not only quick communication with one of the greatest markets west of the Mississippi River, but proximity to city life with its conveniences and pleasures, and minus the annoyances of city restrictions. In reply to many inquiries the writer admits that this is high priced land for an egg farm. We figure we paid \$1,000 per acre for the privilege of living in this particular locality and that \$500 per acre is the value from the standpoint of the business we are engaged in. (To be fair to the biddies let it be said they have paid the whole cost).

Our experimental work was done on a leased place, this property being bought 3½ years ago. The plant, both as to location of the buildings and as to their type and character, is the result of year by year evolution on the leased place, in the course of which most of the successful egg farms in this section of the State were visited. Ideas were obtained from generous poultrymen whose courtesy the writer has already acknowledged and hereby acknowledges again. The land was surveyed and



RESIDENCE ON THE TUMBACH EGG FARM (THIS IS THE HOUSE THE HENS BUILT FOR US)

platted and the location of the various buildings was the subject of study extending over a period of months.

The soil is very light and sandy and the whole place is covered with old peach and prune trees. Reference to the plat will show how the grounds are laid out and the relative location of buildings and yards.

Nearly an acre is given over to the residence and family orchard, this being on the best part of the land—the southeast corner. The long frontage on the boulevard is planted to alfalfa, to a depth of from 125 to 175 feet. This not only keeps the chickens and their equipment from becoming an eye sore to the neighborhood, (as they might be to some if they were directly on this much-traveled thoroughfare), but in addition the long stretch of alfalfa is not only very useful and necessary, but is also, for the greater part of the year, an attractive sight.

The brooder houses and yards, you will see, are located nearest the residence. This is for quick accessibility at night if necessary. The cockerel house is just beyond the brooder houses.

The main feed-house is located almost in the center of the plant. To have it so located means giving up a certain amount of ground for a driveway to it; better that, better we think to make that much of an investment at the outset than to be spending hours of time and a world of labor, day after day, dragging feed stuff the further distance it would have to be carried if the feed were stored at one end of the plant. In one end of the feed house is the tool-room and place for the greens-cutter with its driving motor.

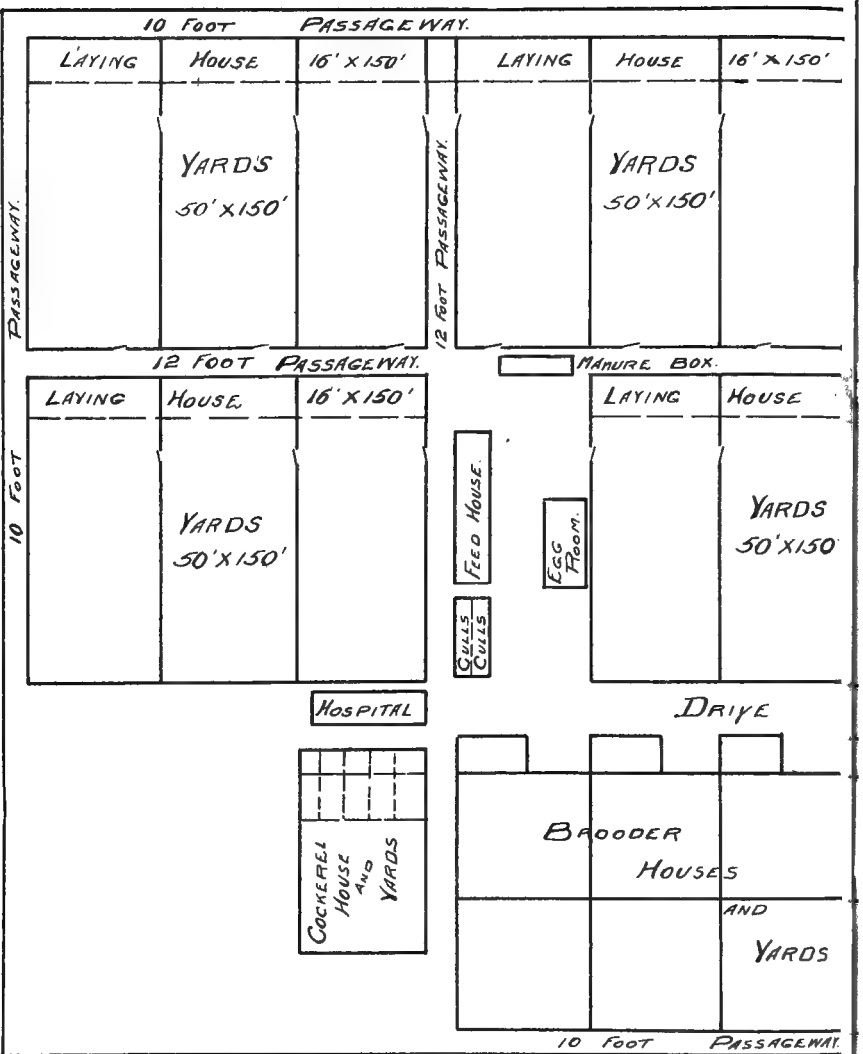



ALFALFA FIELD

BOULEVARD

GARAGE

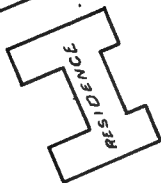

DRIVE

FAMILY

ORCHARD

The egg-room, directly across from the feed house, is also centrally located. The trucks, in which the eggs are taken to market, drive right up to it. The car-shed next to it is for a little delivery car used on odd errands. The grain-sprouting shed with a little storage place for the grain which is to be sprouted are temporary arrangements. Eventually they will be made part of the egg-room building.

The manure-box shown is used for dumping and measuring the manure as it is brought from the dropping boards. The manure is carted away by the purchaser immediately after each cleaning.

On either side of the main feed house is a 150-foot laying house with yards the length of the house and 100 feet deep. You will notice the yard gates open toward the feed house. Behind these two laying houses is a 12 foot passageway, and beyond the passageway are two more 150 foot yards with a 150 foot laying house at the upper end of each. Between the two upper yards is a 12 foot passageway and between the two upper houses is a 12-foot mash-storage shed. The upper yards have gates both near the house, opening into the passageway, and in the lower end, opening toward the main feed house.

The point about the arrangement is this: The grain feed is stored in the main feed house. The feed is carried into the lower yards through the side gates, the greatest carry being 150 feet either way; and for the upper yards it is carried through the lower gates, the furthest carry, when the yards are subdivided, being about 200 feet. When all four houses are filled two men can easily feed the whole flock of 6,000 to 6,500 birds in 15 minutes. The

mash for the two lower houses is laid down in the main feed house, and for the upper houses the delivery trucks back up the passageway and lay the mash down in the upper shed. One hundred and fifty feet either way is the extreme carry.

An old shed is used for storing the feed for the young chicks, located just across the main road from the brooder houses.

The hospital, observation and cull houses are located behind the cockerel house and near the main feed house.

After more than three years of day by day use of this plant the writer can truthfully say that if he had it all to do over again he would not make a single change in the laying-out of the plant or the location of the several buildings.

## **The Buildings**

### **Brooder Houses**

The brooder houses, three at present with space allotted for a fourth, are each 14x24 feet. These buildings are not uniform and are of crude design and construction, having been used on the old plant. (See illustration page 84.) A gable roof is used. The sides are 5 feet high and the peak of the gable is 8½ feet high. The sills are laid on a concrete foundation, in which two ventilators are set to allow a circulation of air under the floor. A tongue-and-groove flooring is used, driven up tight and top-nailed to keep it so. We have different arrangements of windows in each house. The most satisfactory is three 24x36 inch single light sash in the south side of the building, and two 9x14 inch in the north side. The south lights are flush with the plate at the top and the bottom rests on a

girth set to receive it. These windows open from the top. Hinges can be used on the bottom but we nail a very light strip along the bottom, close against the frame, which keeps it from working out; this scheme has the advantage that the windows can be taken out entirely if desired. A strip of light muslin is tacked to each side of the window, fastened to the wall, close up at the bottom, wider at the top; this serves not only to hold the window in place when it is opened but also to keep direct drafts from striking down on the chicks. The little windows in the back wall are set close to the ends of the house up near the plate, and are nailed in place. The main purpose of these little windows is to help the chicks find the roosts. They seem to take more readily to the roost side of the house if there is even a little light there.

A muslin curtain is hung over each of the front windows large enough to cover the glass completely. It is weighted at the bottom by nailing it between two laths, the laths extending several inches on each end. Nails are driven on each side of the window and a wire loop on the end of the lath allows the curtains to be rolled and hung up.

Our most satisfactory brooder house is lined with tongue and groove lumber to a height of three feet. The other houses have a twelve inch board resting edgewise on the flooring, nailed to the studding or to false studs inserted, with a quarter round moulding in the corner; above this a lining of tar paper extends to the plate. We do not use ceiling under the roof. A low ceiling may save fuel, but it makes the room too stuffy.

The door is placed in either end, according to conveni-



ence. But it should not be placed in the center under the gable, but to the south side, so as not to interfere with the roosts.

The opening into the yards is placed in the front wall near one end, across the room from the main entrance. It is 12 inches high and 24 inches long. A slide is preferable.

The roosts are made of  $\frac{1}{2}$ x2-inch stuff running lengthwise of the house, preferably in two or three sections, set 4 inches apart on cross bars of 1x3-inch. They are hinged with T hinges, the flange of the hinge fastening either to the tongue and groove lining or to the 12-inch board. They are set 8 inches high. Made in this way the roost can be hung against the wall until needed.

Ventilation is provided by means of two airshafts, 10x24 inches, made absolutely airtight. The inlet shaft, 24 inches high, is set to one side of the door, a hole being cut in the floor to fit it. A slide cover fits over the top, arranged to slide away from the door. This makes it possible to control the amount of air admitted. A screen of 1-inch netting is tacked across the shaft just below the slide.

The outlet shaft is set in the other end of the building, one edge of it resting against the ridge board. It is fastened against the outer wall and hangs 18 inches above the floor, extending through the roof to a height of 2 feet above the peak of the gable. A little gable covering on top keeps out the rain, the sides being left open for the air passage. These side openings are covered with 1-inch mesh wire. (We once found one of our many family cats sleeping warm and comfortable nine feet below the gable

opening of the outlet shaft on the lower slide.) The outflow of air is controlled by two slides. The lower one is at the very bottom of the shaft, arranged to slide away from the direction of the roosts. The upper one, 9x18 inches, is in the face of the shaft 6 feet above the floor. This upper air slide, a valuable idea, was obtained from the Kresky Brooder Stove literature. The use of it will be learned in the discussion of brooding.

We use the stove method of brooding. From the description given it will be seen that we do not use the two-room, or cooling-room, plan.

An automatic alarm system is in use in the brooder houses. This consists of a thermostatic plate with two points of contact, adjustable in both directions, wired to a bell (and batteries) located in the sleeping porch of the residence. The thermostat is hung about 12 inches above the floor, 3 feet from the stove and facing the stove. Properly adjusted, and this can be done only by considerable patient experimenting, this alarm system is well worth its cost both in money and in the time spent on it. The best of us are liable to overlook the fuel tank some mean, fretful day; or a stove may go wrong even with a full fuel tank; or the needle valve in the feed line may stick—we know from experience that the alarm system is valuable.

We have been asked why we build our brooder houses in separate units instead of having one long building, which would save walls, fuel and footsteps. The latter idea was considered and discarded because we do not care to risk all the eggs in one basket—the danger of fire is present wherever a stove is used, especially so when oil

is the fuel and the floor is covered with straw. The burner must be cleaned regularly, and especially with very young chicks one cannot let the flame die out entirely; it would take too long to start it up again and bring the temperature back. The tiniest splash of burning oil on the bed of warm straw would spell the doom of the house and all in it; and we think we have a chance to save the other houses when there is a reasonable space between. Ours are set from 15 to 20 feet apart.

The brooder yards are each 40-50 feet wide and 90 feet long, subdivided into three sections. The first section is 18x24 feet. It is surrounded by a 2-foot fence. (See illustration page 84.) An 8-inch board is used at the bottom and a 3-inch strip at the top. One-inch mesh netting covers the intervening space. A panel made of 12-inch boards is kept in the yards and on windy days, also when the chicks are first turned out, the panels are fastened into place, forming a 2-foot windbreak and shelter all around this first yard. A sloping 2-foot roof extends inward from this fence, about 30 inches high on the inner edge, forming shade in hot weather and protection during light rains when the chicks may be outdoors.

Running water is provided in this first yard, under the roof, a shallow crock and a float valve being used.

The second division of the yard is about 20x50 feet. This yard is enclosed by a fence with an 18-inch strip of 1½-inch mesh netting at the bottom and 6 feet of 2-inch mesh netting above it, the base board being 10 inches wide. There is quite a saving in this form of fence construction. Twelve-inch lumber costs more in proportion than 10-inch; and under present market conditions the difference

in price between 1½ and 2-inch poultry netting is considerable. Where the netting joins it can be permanently fastened together by twisting it with a light nail.

The third division of the yard, about 50x50 feet, is fenced with 2-inch mesh netting. Octagonal netting is preferable to the square kind that has graduated openings, for fencing growing chicks. The little chaps easily learn the trick of climbing up the square meshes until they reach an opening large enough to let them through.

Our brooder yards are larger than common and it has been suggested that this is a waste of land. We think it a most beneficial practice to have a succession of yards in growing green stuff into which the chicks can be turned as they develop. In addition, we use the brooder yards for growing green stuff (barley) for use during the fall and winter months when alfalfa is not available. If we had no such space available we should have to allow more space elsewhere; and under this plan we have the benefit of the fertilizer already in place.

### The Cockerel House

The cockerel house is 9x50 feet, shed roof, 5 feet high in back and 7 feet in front. The upper 30 inches of the front is open, covered with 1½-inch wire netting, protected with a canvas awning. The awning is made in 10-foot sections, 1x2 stuff being used for the frame. The canvas is fastened to the frame with broad-headed roofing nails. The awning is fastened to the plate with three 5-inch strap hinges; the end of the hinge projecting beyond the plate is bent back against the plate on the inside, which makes it more rigid. Two quartering braces

are used on the lower end of the frame, made of  $\frac{1}{2}$ x3-inch redwood. This awning can be used to close the house fairly tight when the cockerels are first taken out of the brooder houses; later it is kept half open by propping it.

The house is divided into five compartments, each 9x10 feet. A slide door, 12x18 inches, opens from each compartment into the yards; and 3x6-foot doors, hinged toward the back wall, afford passage into the house and from one compartment to another. We find this arrangement preferable to having large doors opening directly into each yard from the several compartments. The outside door is outside the yard—this avoids opening a gate for entrance to the house. The roosts are of 1x2-inch stuff set 8 inches apart, 12 inches above the floor. These roosts are not hinged. They are nailed to 3 cross pieces under which blocks of 2x3-inch stuff are spiked. In cleaning the house the roosts are tilted back against the wall.

The yards are each 10x16 feet with a gate in the end of each section. A 10-inch base board is used, above which is an 18-inch strip of  $1\frac{1}{2}$ -inch wire netting and above this is a 6-foot strip of 2-inch netting. Beyond the sectional yards is a larger yard, about 50x50 feet, for use when cockerels for breeding purposes are matured in the cockerel house. On this yard 6-foot netting of 2-inch mesh is used. Running water is had in each sectional yard, a 4-inch crock being used.

The frame of the house rests on a concrete wall 6 inches high. The floor is of tongue and groove stuff, driven up tight and topnailed. The flooring runs cross-wise of the house, making it easier to clean.

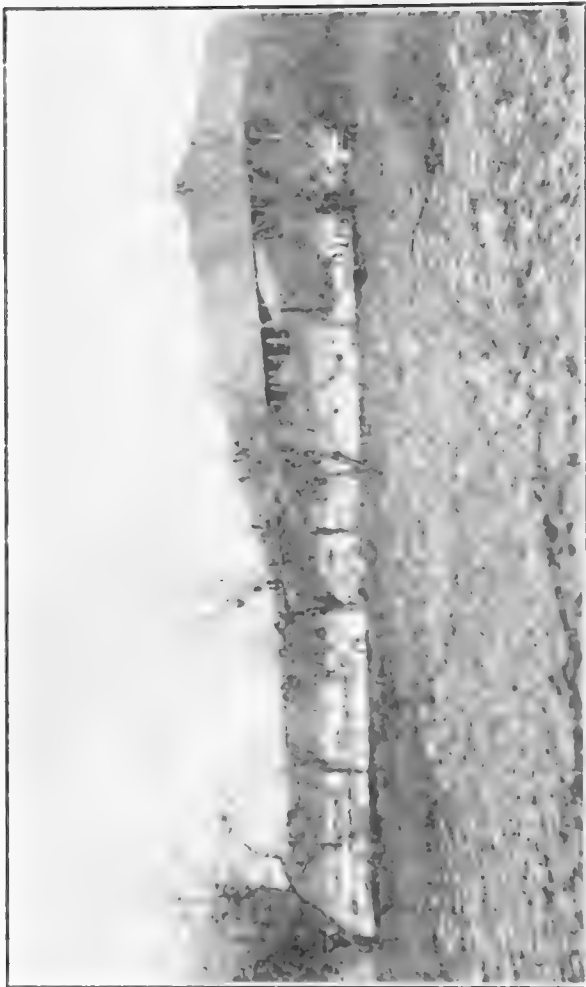

VIEW OF 300-FOOT LAYING HOUSE (AWNINGS REMOVED) ON THE TUMBACH EGG FARM  
(THIS IS THE HOUSE WE BUILT FOR THE HENS)

### Laying Houses

The laying houses are an adaptation of the Corning house, 16x150 feet, shed roof, 6 feet high in back, 8 feet 5 inches in front. A concrete wall is used on the back and on both ends, **but not in front**. The height of it is governed by the slope of the land as suggested in the chapter devoted to "Planning the Plant." The floor is of 3-inch concrete, medium rough finish, with a slope of 2 inches toward the front. The reason for this slope and also for the absence of a wall in front is that the house can be washed out with a hose when it is desired to cleanse it thoroughly. The front sill is raised 1 inch above the concrete floor by inserting blocks under the sill where the studs strike. One-half by 8-inch bolts are set in the concrete both in the back wall and in the front edge of the floor where the sill will rest. This fastens the structure firmly in place. We use 2x3-inch stuff for the sills, girth, plates, studs, and drop-board joist, and 2x6 inches for the rafters which are 18 feet long with a 6-inch eave in front and 12-inch in back. The wall sheathing may be tongue and groove stuff or board and batten, whichever is the cheapest. But sound lumber should be used to avoid cracks. The girth (for the back wall) is set 30 inches above the concrete floor, regardless of where the sill strikes. This is done so that it may be used for the rear joist of the drop board.

A ventilator is set in the center of each 16 and 18-foot compartment, in the back wall, under the dropboards. They are 10x24 inches, covered with 2-inch netting, and should have a slide or hinged door. These ventilators are opened when the first hot weather comes on and re-

main open until late in the fall. Should a cool spell set in in the meantime they are closed temporarily.

The dropboard is 7 feet wide, of tongue and groove stuff, driven up tight and nailed side and top. Two joists are used in addition to the rear girth. The front joist is set back 3 inches so that a wheelbarrow can be run under the dropboard at cleaning time. The top of the joists are kept at 30 inches above the floor level, giving the dropboard the same slope as the floor. The dropboard is put on crosswise of the building, in 7-foot lengths, for ease in cleaning. A moulding, made of 1x1-inch stuff cut diagonal, is nailed in the corner where the dropboard and the rear wall meet; this prevents accumulation of droppings in the corner.

Six roosts are used, running lengthwise of the building. They are made of 2x2-inch stuff, toe-nailed on two sides to 2x3-6 crossbars, all of it dressed on four sides with the upper edge of the roosts proper rounded at the mill. The first roost is set 8 inches from the rear wall, the balance at 13 and 12-inch intervals. Four crossbars are used in each section and the roosts are made in 8 and 9-foot lengths, according to the length of the section. The roosts are hinged to the rear wall with 6-inch strap hinges; the top is 8 inches above the dropboard. A block 2x3 inches, set under each crossbar 12 inches from the forward end, forms the front support.

The house is divided into three compartments of 50 feet each. A description of one compartment will serve for the entire house: Each compartment is divided into three sections, two of 16 feet and one of 18 feet. The compartment partitions extend across the whole house;



the section partitions are 9 feet wide, extending 2 feet beyond the width of the dropboards. All partitions are made of tongue and groove stuff, nailed both side and top. The sills are of 2x3-16, extending from the rear wall to the front sill. The rafters are used for plates. A 2x3-inch girth is set at center between the rafter and sill, sloping with the rafter.

The compartment doors as well as the outside doors, one in each end of the building, are 42x72 inches. The compartment doors are hinged toward the front—they swing toward the nests. This is to avoid hens flying from the nests through the door when it is opened suddenly. The compartment doors are 6 inches short of the floor and a 6-inch board, set in grooves, fills the space. This obviates the doors being blocked by litter; the purpose of setting the board in grooves is to enable its being removed when the wheelbarrow or cart is taken through at cleaning time.

All doors and gates on the place are equipped with Conrad Gate Latches, one of the greatest conveniences we have on the place.

The front of the house involves a tedious description and if that description is given in crude terms it is because it is intended for non-technical understanding.

We already have the 2x3 sill resting on 1-inch blocks, bolted to the concrete. The studs are 8 feet long. They are set at intervals of 4, 8, 12, 16, 20, 22, 26, 28, 32, 36, 40, 44, 48 and 50 feet. The purpose of the odd setting is to make place for the frame of the water shed which will be described later and of the partition already described. The 2x3-inch plate gives us the total height of

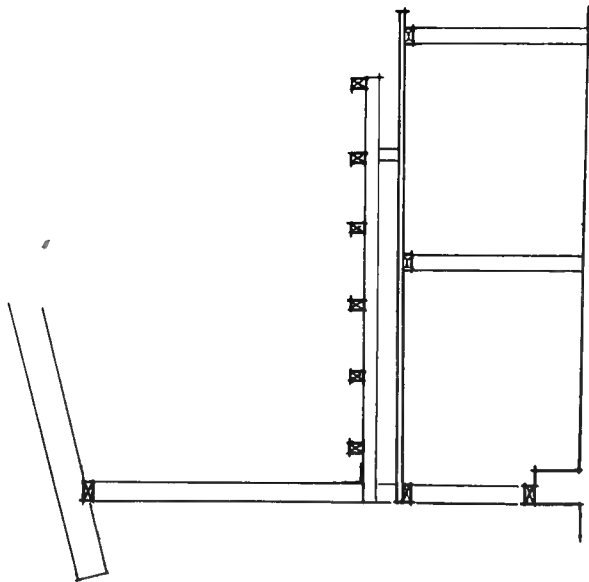
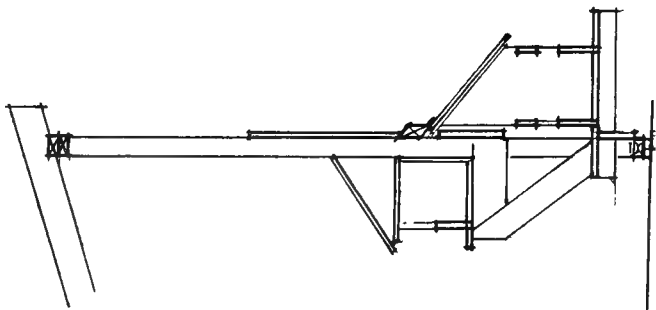

CROSS SECTION OF LAYING HOUSE ON THE TUMBACH EGG FARM

8 feet 5 inches. A 1x6-inch board is nailed on the outside of the studs, flush with the bottom of the sill. This leaves the 1-inch opening below the sill clear. A lath is tacked on the inside of the sill to cover this opening. The 1x6 is notched at each stud deep enough and wide enough to insert a piece of 1x3 crosswise of the stud, set on edge. This crosspiece is 29 inches long. It extends 6 inches inside the house (3 inches past the stud), and is nailed flat against the stud. It must be set level. The trough rests on these crossbars, on the outside of the house. A piece of 1x8 follows, for the trough step. This is laid flat along the projecting end of the crossbars, inside the house, and is notched to pass the studs, the notches being made deep enough so that the board will extend 2 inches beyond the studs, outside the house. It is nailed to the crossbars and also into the top of the 1x6 below it. The reason for extending it outside the house is to avoid dirt and refuse, which lodges on the trough cover, falling into the trough when the cover is tilted. A 15-inch opening is left above the 1x8 trough step for the trough. Two pieces of 1x6, or one 1x12, is next nailed to the studs. Above these an opening of 3 inches is left. This is to allow free play for the trough cover. Above this opening a weather strip is used. This is made of a 2x6, preferably pine, bevelled on both edges to a depth of 2 inches, leaving it 4 inches wide on each side. The upper bevel turns the rain and the lower allows the trough cover to slip under it, making the cover rain proof. The reason for using pine for this strip is to make a secure fastening for the hinges of the cover—screws will not hold for any length of time in redwood, especially if the

hinge is in constant use. Above the weather strip either siding or tongue and groove stuff may be used. If siding is used it will be necessary to add a short false stud between each stud; if tongue and groove stuff, a top and bottom girth must be run from stud to stud. We have both in use. We use 1x3 for the girths, and also for the false studs. The upper 30 inches is left open and is covered with 2-inch mesh netting. An awning is used over this opening, the details of which may be found in the description of the cockerel house. The awning is held open at all times, excepting when young pullets are first put in the laying house, by means of a wire nailed to the end of the rafter, wrapped 'round a nail driven into the lower edge of the awning frame, and pulled tight to a nail driven into a stud above the trough cover. Three wires are used on each awning. This holds it absolutely rigid.

The rafters, of 2x6-18, are set at 4-foot intervals with an extra one over the 50-foot stud, and are notched front and back. The cantboard is of 1x6—preferably of redwood. To make the joint absolutely tight we put in the cantboards when the rafters are set. The first rafter is nailed in place. The cantboard is cut to proper length and is set on top of the plate, flush with the inside of it. (This avoids a dust-box on top the plate.) The next rafter is set against it and spike-toe-nailed into the plate, against the cantboard. When a section is completed the projection of the cantboard is planed smooth with the rafters and the roof sheathing is nailed to it.

The roof sheathing is of 1x6; we prefer 12 and 16-foot lengths, to which there is no waste if the rafters are set

as directed. Two or 3-ply composition roofing is used with a layer of tarred felt under the roofing to protect it against the spraying materials. Both the felt and the roofing is run lengthwise of the building. A 1x6 cornice board is run along the front edge of the rafters.

#### Water Shed

The water shed is 5x8 feet, extending outward from the main building between studs at 20-28 feet. The floor is of concrete and two bolts are set in the outer edge of the concrete 18 inches from each outer end to make the front rigid; 2x3 sills are used, 1x3 girths, and three 2x3-6 rafters, the rafters being used for the side plates. A piece of 1x3-8 is nailed crosswise of studs 20-28 to support the upper end of the rafters. Four studs, 2x3-6 are used in front, set at 0, 2, 6 and 8 feet, capped with a 2x3-8 plate on which the lower end of the rafters rests. Two doors are swung between studs 2-6, opening outward, an old fashioned bar and socket barn door fastener being used on the outside to hold the doors closed. The entire front of the water shed, doors and all, is but 5 feet high, leaving an opening of 12 inches, to admit light and air, which is covered with 2-inch mesh netting. To catch the wire, the outer boards on each of the doors is left 6 feet long. Two sliding doors, 18x24 inches are used in the sides of the shed close to the front edge. The purpose of these smaller openings is to allow the front doors to be kept closed during hot weather, shading the water pots. The sheathing may be either of siding or of tongue and groove stuff.

No door is used between the water shed and the main building, but a piece of 1x8 is nailed flat against the studs,

flush with the studs at the bottom, to keep the litter out of the water shed. Two water pots are used in each water shed, placed near the front edge. The supply pipe runs along the front of the house and a connection is run into the water shed, dividing at the door and one branch running to each side of the shed. We use the "Float Boy" water valves, which are self-acting.

### Mash Troughs

The mash troughs extend from each end of the building to the water shed and are made in four sections, two of 10 feet each on one side of the water shed and one of 10 and one of 12 feet on the other. A 12-inch board is used for the bottom. A piece of  $\frac{1}{2} \times 7$  is nailed on each side, giving a depth of 6 inches inside the trough. The opening is  $3\frac{1}{4}$  inches. Above this a strip of  $\frac{1}{2} \times 3$  is used. The crossbars, one at each end and one in the center, are made of 1-inch stuff, 2 feet long, sloping from the upper edge of the top bar to the top. The end cross bars should be nailed to the side of the base board—not on top of it. This makes it rain proof.

This trough is 13 inches wide if the specifications are followed. It is set on the  $1 \times 3$  cross bars and when it is in place a  $1 \times 8$  board is set close against it, nailed to the cross bars, and forms the outside step. The cover is made of  $\frac{1}{2}$ -inch stuff, 24 inches wide, nailed to five cleats of  $1 \times 3-2$ . The upper end of the cleats are bevelled to allow the cover to fit snugly against the studs. One-ply composition roofing is used over the cover, fastened to place with laths nailed down into each cleat. Three 6-inch strap hinges are used on each section of cover, fastened with  $1\frac{1}{2}$ -inch screws. The hinges are set 1 inch from

the upper edge of the cover, to allow the cover to slide into place under the weather strip. If the weather strip has been correctly set the cover will rest on the slope of the trough sides and will open and close readily. To hold the cover open while filling the trough a wire is nailed to the stud nearest a cover cleat, with a loop on the end of it. A nail is driven into the side of the cleat (inside the cover) and the wire loop is slipped over it. (See page 120.)

Before the troughs are set in place the nest brackets are put on. These brackets hold the trough cross bars rigid. One is used at each stud. They are made of 1x6 redwood. The horizontal bar is 17 inches long and the top of it is 30 inches above the concrete floor. It must be set level. The support extends from the outer upper edge of the horizontal bar slanting downward to the stud and is cut to rest over the inside trough step. When this bracket is in place properly set and securely nailed you can stand on the trough and it will not sag.

### Nests

The nests are made in 4 sections, three of 12 feet and one of 10, extending along the entire front of the house (inside) excepting for the 4-foot entry into the water shed. They rest on the brackets just described and their weight holds them in place. The bottom board is of 1x12 stuff, the back of  $\frac{1}{2}$ x12 and the top consists of one piece of  $\frac{1}{2}$ x6 and another of  $\frac{1}{2}$ x8; this allows a slight overhang in front. The front is of 1x6, nailed flush with the bottom of the 1x12 board, making the depth inside (in front) 5 inches. The back piece is nailed in the center of the bottom board which leaves a slight opening at the top. This makes the nest cooler than it would be if

closed solid. The partition pieces are of 1x12 cut into lengths just a trifle short of one foot each. They are set at intervals to make one compartment to each running foot.

The running board or step, which is used also to close the nests at night, is made of 1x3 stuff, the length of the section. About 18 inches from each end a 6-inch piece of 1x3 is nailed to the running board on what will be the outside of it when the nest is closed. To put it another way, put the cleats on the ground with the running board on top of them; the hinges can then be put on in their proper position. A 3-inch strap hinge should be used. Fasten the hinge to the cleat, "upside down"; instead of having the screws run down into the slot, which brings the screwheads flush with the surface of the hinge lay the hinge face downward, which leaves the screwheads exposed. The completed nest ready for the running board is most conveniently set on the ground with the front, the 6-inch board, on top. Place the running board on it. It is flush with the 6-inch front board. The hinge cleats will fit flat against the 6-inch board, and the lower section of the hinge will also lie flat, with the screw-grooves up. A 2-inch space is left between the 6-inch front board and the 3-inch running board; this leaves the cleats extending downward 1 inch from the top of the 6-inch front board. This is the closed position. A notched latchet, made of wood, is fastened to the center partition board, patterned so that it will raise and lower readily. The notch should be deep enough so that the step is not likely to be jarred loose when hens fly against it.



The final part is three supports to hold the running board in the open position. These should be six inches long, one near each end and one in the center. To get their proper position hold the running board squarely at right angles to the nestbox (the hinges must first be fastened to the 6-inch front board) and toe-nail the three supports in place so that the running board drops on them evenly. This is the best combination running board and nest-closing arrangement the writer has ever seen. It is the idea, one among many in use on our places, of the writer's father-in-law, Mr. W. C. Freeman.

Above the nest is a protector, designed to prevent the hens roosting over the nests. This is made of 3 pieces of  $\frac{1}{2}$ x6 stuff, nailed to 5 cleats, of proper length to cover each section of nest boxes. The lower edge of it rests on the slight projection of the top of the nest and the upper edge lies against the studs. It is nailed to the studs but not necessarily at the bottom. The nest boxes can be lifted out at cleaning time if desired. An open space is left between the studs which provides a meager footing for the more ambitious young pullets, but we seldom if ever find one staying there all night; the position is too uncomfortable.

#### Broody Coop

A broody coop is put in each compartment, under the dropboard, and covers one-half the center section. The bottom support or sill is made of one 1x6-7 and one 1x6-8, standing on edge and nailed together at right angles.

The outer edge of the front drop board joist serves for the front plate and a strip of 1x3-7 is nailed to the joist

legs, flush with the 1x6 at the bottom. The space between should be covered with lath, set  $2\frac{1}{2}$  inches apart. We used 2-inch mesh netting but the hens eventually break through. A little door is put in the front section. The coop is placed in the center section to have it close to the water supply. We use two gallon galvanized cans (specially built) with a pan soldered on the front edge, operating on the cup and saucer fountain principle, and with a screwcap filler opening on the bottom. It is provided with a swinging handle on top, by means of which it can be hung at a proper height from a nail in the wall. We use two roosts in the broody coops.

### Yards

The yards run the length of the house (150 feet), and are 100 feet deep. A partition fence is run through at 50-foot intervals, conforming to the inside sections of the house. The fences are fastened to the southeast and southwest corners of the house, leaving the outside doors of the houses clear. The fences are built of 3x4-10 redwood posts, 1x10 redwood for baseboards, and 2-inch poultry netting 6 feet high. The posts are given two coats of half creosote and half crude oil to a depth of 36 inches and are set 30 inches in the ground. The sideline posts are set, the first one  $8\frac{1}{2}$  feet from the house with another at 12 feet, forming the gateway; the next at 20 feet, and thereafter at 16-foot intervals. The ends are set in two intervals of 16 feet and one of 18, excepting for the upper yards in which a  $3\frac{1}{2}$ -foot gateway setting is made in the 18-foot section. These post intervals are most economical of baseboard material and have been

found satisfactory. Braces of 2x3-7 redwood are used, which should have the steepest possible pitch to obviate birds climbing them. No top boards are used.

The gates are built with the upper crossbar 18 inches below the top of the wire. All gates swing inward, the upper ones (nearest the house) toward the house rather than away from it.

### **Hospital, Observation and Cull Houses**

We have several small houses, with appropriate yards, used for hospital, observation, and culling purposes. All of these are made up of odd buildings accumulated during our earlier experience on a leased place. Such spare quarters are not only a great convenience but an absolute necessity on a plant of any size. The construction of the buildings and their size is of no importance. We make a special point, however, of providing not only tight, comfortable sleeping quarters in all such places but in addition ample shade and shelter and water faucets are provided in each.

In the hospital section at least two divisions should be available, a small one in which sick birds are first isolated and a larger one for what we call the convalescents. The isolation yard on our place is surrounded with a solid board fence about 3 feet high, with 5 feet of netting above it. The house is but 4 feet deep and has a dropboard 2 feet above the floor; but roosting quarters are provided on the floor as well as on the dropboard. Fresh straw is put into these quarters after each cleaning and the houses are always sprayed when cleaned.

### **The Feed House**

The details of the feed house are hardly of importance. This may be built according to taste and purse. Our building is 16x40 feet, of which 16x20 is used for feed storage. The floor is of concrete. Our close proximity to source of supply makes it unnecessary to carry any great quantity in storage. Where this is not the case it will be necessary to have greater storage space. It might be mentioned, in this connection, that we do not speculate in grains and feedstuffs; we buy as we need.

### **The Egg Room**

The egg room, just completed, may be of interest. It is 16x17 feet and rests on a 5-inch wall of concrete. The building runs north and south. On the northerly end an excavation was made for a shallow cellar the width of the building, 36 inches wide and 30 inches deep. The concrete foundation which extends all around the building runs to the bottom of the excavation. The floor joists of 2x4, properly supported, run crosswise. An interval of 3 feet is allowed over the cellar. The balance of the room is floored with tongue and groove flooring. The cellar covering is made of flooring in 3-foot lengths made into 4 trap doors which can be lifted against the north wall and held in place by looped wire catches. Filled cases are set on the edge of the cellar way and can be easily and conveniently lifted down or up. This arrangement obviates the drudgery and labor of dragging the eggs up and down cellar steps. Anyone who has been through it, especially during wet weather, will readily understand why we fought shy of the old scheme.

The cellar is used exclusively for hatching eggs. We can store 30 cases in it without crowding. Two ventilators are set in the foundation, one in the south end, the other in the west side 5 feet south of the cellar. They are covered with 1-inch mesh netting.

The building is set on sloping ground. The main entry is a 3-foot door on the west side, just south of the cellar. One step leads up to the floor. On the south side the floor is 2 feet above the driveway. A 3-foot door was put in the southwest corner. The delivery truck can back to this doorway and the eggs can be loaded onto the truckbed with but little lifting.

### Cost of Buildings

It would serve no purpose, under present prevailing conditions, to record the cost of our buildings. Prices of materials have advanced to such an extent that no comparison can be made. The last of our laying houses was built in the fall of 1917. The 150-foot house and fences complete cost \$620 (in round figures) for materials alone; the labor cost cannot be given for any of the buildings because the writer did a very large share of it himself.

Our total investment in buildings and accessories, including water lines, fences, etc., is \$3,500 in round figures. This is entirely exclusive of labor; it covers materials alone. The amount paid out for labor in construction of the plant would not exceed the labor cost in building one of the large laying houses.

An idea of the size of the plant may be obtained from the fact that we have more than 10,000 square feet of concrete floors and about 13,000 square feet of composition roofing on the place.

## PART FOUR

A detailed description of the methods followed on The Tumbach Egg Farm.

— — —  
And this is

“How I Made \$10,000 in One Year with 4200 Hens”

### Hatching

All of our hatching is done at a commercial hatchery, the eggs being supplied by us from our own stock. This course was adopted after several years of experience in doing our own hatching. Much may be said in favor of either system but the arguments would leave us where we started; that is, that we leave the hatching to the man who makes hatching his business. When brooding time comes, bringing with it thousands of chicks, we have nothing on our minds but the care of those chicks.

The eggs are marked with a rubber-stamp to avoid any possible confusion. It then becomes a matter simply of the honesty of the hatcher as to whether or not we get the chicks from our own eggs.

We pay the hatcher so much per thousand eggs, regardless of the number of chicks hatched.

We usually provide 6 cases (2160 eggs) for each hatch and we count on about 1500 chicks from this number. In a year of poor hatches we are likely to fall short and in good years we run over that number. The long haul in a truck—our eggs are carried 25 miles—reduces the hatchability of the eggs of course; this has been taken into consideration. The hatcher calls for the eggs at our place and delivers the chicks. In both respects he is better equipped and more experienced as to the safest method of carrying than we are or could be.

### Carrying Baby Chicks

To those who carry their own chicks a word of advice might be in order: The chicks must have air and warmth. If you are stacking up a lot of the familiar 100-chick carrying boxes in a motor car be sure the boxes are criss-crossed in such a way that each box will have air. The boxes should set level, otherwise the chicks will be jammed to the lower section of the box. If necessary place strips of wood between the boxes. As to warmth, the chicks will supply all they need for the trip, but this will not protect them against the draft made by the moving car. Excepting in hot weather it will be necessary to put a blanket over the load to keep off the draft, and even in hot weather a curtain of some kind should be hung in such a way as to stop the draft. It should be kept in mind that newly hatched chicks differ in no essential respect from a very young baby so far as susceptibility to draft is concerned, and the writer's observation is that a careful mother who carries the baby in a motor car quite generally has it completely covered.

Should you meet with an accident on the road or if it is necessary to stop for as long as 10 minutes you should remove the blanketing—the draft stops with the car. We heard of an instance where a poultryman carrying a load of one thousand or twelve hundred chicks was delayed half an hour. He forgot to remove his blankets; and he smothered more than half of the chicks. On the other hand we have known of many cases where chicks were chilled by the draft and a heavy mortality was the result, which was of course blamed on the hatcher and the stock he hatched from.

We are extremely careful with newly hatched chicks. If it becomes necessary to transfer some from one house to another we either use one of the cardboard chick boxes on which the lid can be set down tight, or else, if an open box is used, we put a gunny sack or a piece of flannel over the chicks before going outdoors. This may seem "fussy"; it must be remembered that your care of these chicks will make or mar your whole year.

If your chicks are shipped to you by express, learn the exact time when the train is due and be there to meet it. Do not chance a careless expressman setting them outdoors in the rain or snow and wind; or a careful one putting them next to the stove. Either course may cause you not only loss but a lot of misery and trouble.

### Selecting Eggs for Hatching

We use no egg for hatching that weighs less than 2 ounces and we discard exceptionally large eggs also. The egg must be of normal shape, and must have a perfect shell. "Pimples" of lime in the shell; shells with ridges and water-marks; shells that clink like glass on being tapped with the fingernail—all these are discarded, likewise, of course, any that are checked—by which is meant a crack in the shell which may or may not be a complete fracture.

We take no chances of mixing hatching eggs with the general run—the buckets are marked with a card as they are brought to the eggroom, and the eggs discarded from the hatching eggs are never packed for market directly; they are put into a bucket and are graded and packed out of the bucket. With our years of experi-



ence in packing we still deem it unsafe to try making the double grading in one operation. Should the cases become mixed the cost would be too great—especially if the eggs are sold.

### **Time of Hatching**

Our first brood of chicks is brought off the second or third week in January and we have either two or three lots in that month, one week apart. These are followed by three lots in the month of March, also one week apart. This arrangement allows for keeping the first hatches in the brooder house a maximum of 8 weeks should a streak of bad weather be encountered. This leeway of time has saved us a great many chicks that would otherwise have been forced out of the brooder houses to make way for another lot regardless of extremely adverse weather. It was to avoid being so forced that we used three brooder houses earlier in our poultry career when we brooded only three lots in one season. Most poultrymen would agree with us, we think, that the greatest single factor in chick mortality is lack of proper housing facilities. It has come to be a common thing to hear, "I lost a lot of young pullets in my early hatches; I had to put them in colony houses to make way for another hatch coming off."

### **Foreword on Brooding**

The description of our brooding methods will be embellished to an extent which to those of experience may seem even absurd. It is the writer's purpose to give herewith a definite line of procedure for a novice to follow; as he expressed it in an outline, "I would have the chicks arrive and make him feel at home with them, not

like a hopeless idiot. I would take him along, day by day, morning, noon and night, knowing just what to do at each stage of the game." When this novice has graduated he can do his own eliminating of non-essential features and make such changes as will best fit his own particular case and habits. But at the start, assuming that he knows nothing whatever about handling the chicks, we purpose giving him something to go on.

### **Getting Ready for the Chicks**

The chicks are delivered to us 36 to 48 hours out of the incubators at which time they are ready for their first feed and water.

About one week before the chicks are due the brooder house is in order. If it is a new one it has been thoroughly sprayed; if an old one it has been cleaned, washed out with a hose and nozzle, allowed to dry and then sprayed. If clean sand, reasonably free from dust and dirt, is available, the floor is covered with it to a depth of about one inch. A light scattering of clean, bright straw, preferably wheat straw, is put over this; if barley straw must be used it is put through the feed chopper and cut into one inch lengths. If clean sand is not to be had none is used and the straw is made about two inches deep.

The stove is started up and tested out thoroughly, running several days if necessary to get the proper adjustment and to be sure it is working properly. The automatic alarm system is gone over and put in working position, the thermostat hanging by its wires (from a rafter) 12 inches above the floor, 3 feet from the stove

and facing it. A thermometer, known to be registering accurately, is hung from the bottom of the alarm-thermostat, also facing the stove, the bulb hanging about 2 inches above the straw. The inlet air shaft is opened about one inch and the outlet shaft about three inches on the bottom slide, the upper slide being kept closed. The heat is run up to 95 degrees. The alarm is set to ring the bell if the heat drops to 90 degrees (this is brought about by shutting off the stove), or if the heat rises to 100 degrees. Under ordinary weather conditions the space between either the hot or the cold contact points will be about the thickness of a worn dime; but nothing short of experimenting will determine the exact setting.

The house is allowed to warm up gradually rather than by forcing the stove. As already said, it may be necessary to extend the warming-up and testing out experiments over a period of several days. When the proper adjustments have been reached the stove is shut off until the day before the chicks are due to arrive. On the morning of that day it is started up again; and it continues running from that time on. The burner is cleaned and scraped some time during the morning of the day the chicks are to arrive so that it will not need attention just after the chicks are in the room.

A ring of 1-inch mesh netting, 12 inches high, about 14 feet in diameter, covered with muslin, is set around the stove. This is to keep the chicks from straying. The muslin is fastened to the netting at the top by stitching thread, and is on the inside of the netting. It must be fastened in place with the netting set in the form of a circle; if the netting is laid flat the muslin will bulge and

the chicks will crawl under it and bunch up between it and the netting and many of them will squeeze through the wire. The ring should rest on the flooring, the straw being banked against it.

Tar paper is cut into strips 2x3 feet, about 8 being used for 1500 chicks. These strips are put down inside the circle. A light scattering of chick grit is thrown over them, likewise a light scattering of hulled oats, cracked wheat and fine cracked corn (equal parts by weight). About an hour before the chicks are due the little cup and saucer chick fountains are filled with water from which the chill has been taken. We use one fountain to 100 chicks. These are scattered promiscuously inside the circle, some of them very close to the stove, others on the tar paper. Tilt the "cup" slightly for an instant so the water will come up to the very edge of the "saucer."

Then we are ready for the little newcomers.

And if you purpose following our plan in caring for chicks, take this much advice: Work all night if you have to; but have that brooder house absolutely ready for your chicks at least 24 hours before they are due to arrive. We have heard of cases where the deliveryman from the hatchery had to assist in putting up the brooder stove intended to warm the chicks he brought in the month of January. From the writer's point of view this is little short of criminal; true enough, he views it from a prejudiced standpoint, the standpoint of one who really loves the birds and especially baby chicks. But almost any human being worthy the name would resent the idea of chucking a lot of helpless fluff balls, just out of a temperature of at least 103 into a damp,

cold house, and certainly no one has the right to expect them to do well in such hands.

### Method of Brooding

All available help is called into action when a load of chicks arrives and they are unloaded as quickly as possible. The first boxes are carried to the farther side of the room. They are set on the outside of the wire circle, half of them on each end of the house. They are not piled up. On a hot day the lids are taken off the boxes as they are set down. If the sun is bright and strong the curtains are dropped over the windows to keep the chicks from crowding toward the strong light.

Set a box close to the circle, sidewise, kneel down by the side of it and lift the chicks over the wire in bunches of five. Dip right into them with both hands. Have a pencil handy, and when you have emptied a box, mark on the lid of it the number of chicks you counted out. If dead ones are found toss them aside into one pile and count the dead when the live ones are all out. Don't drop the little chaps if you can help it—some men can handle them in what appears a rough manner without hurting them but this comes from long experience.

Move as rapidly as you can and don't mind the chirping; you will grow accustomed to it. They will "chup" quite a bit for a day or two until they have settled down. Meantime you will be surprised to see many of them drinking and eating before you get the last box emptied. The idea of tilting the fountain is to bring the water to the very edge so that when a little bill is laid to it the moisture is found at once. You want to get them started

in the shortest possible time and you are doing everything you can to make it easy for them.

If you had things arranged as outlined you now have nothing to do but pile up the boxes and remove them. In doing this we always look through them carefully to be sure no chicks are overlooked. Next you should tack a large card on the wall of the brooder house, near the door, with a lead pencil hung over it by a string. On this card mark the date and number of chicks received, and as losses occur, mark them down. If you wish to learn the periods of heaviest mortality, mark off squares on the card and put each day's losses in a square. You will find such a record both interesting and instructive. We make no distinction between chicks found dead and those that we help out of the way.

And then you can sit down and "size them up." The chicks themselves will tell you in a short time whether or not your temperature and ventilation are right. Different lots require different degrees of heat and outside atmospheric conditions will necessitate a variation in the supply of air admitted. If it happens to be a very hot day you may have to lower your heat and increase the air supply immediately. In such case the chicks will pant for breath, some of them racing about, others "chupping" madly. If this continues for as much as say five minutes, open your inlet air slide to full capacity and open the upper outlet slide about half way; then turn down the regulating screw on the stove, giving it two or three full-round turns. This will reduce the heat and increase the fresh air in a very short time.

Give the chicks a chance to settle down in the new

atmosphere before making further radical changes. If they quiet down and begin to take an interest in water and feed, close the upper outlet shaft slide and increase the opening in the lower one. Then leave them to themselves.

On the other hand, if they crowd each other and pack together, even right under the hood of the stove, run up the temperature by turning up the regulator screw; but do this slowly. Turn it a quarter ways around, leave it for a few minutes, until you hear the buzzing of the flame, then turn it a little further, and so on, until you have raised the temperature two or three degrees. Then leave it at that for half an hour or so; and if, after that length of time they are still crowding the stove, repeat the operation, and continue doing so until they scatter and take to the water and feed.

Meantime some of them may show an inclination to peck one another's toes; this is not serious at this age. If you wish to take no chances of their getting started on a rampage of toe-picking, catch the chaps that do it and give them a drink. Hold the little fellow between your thumb and middle finger, leaving the index finger free. Take him to a fountain, and with the index finger "duck" his head to the water. Don't hold his head down very long—he must raise his head to get the water where he wants it. Then remove one fountain from the ring, tear off an edge of tar paper, put a little feed on it, and set your toe-pecking chap outside the ring with this feed and water to amuse him. Don't forget him, though, and step on him later on or leave him out all night.

Chances are that in an hour or so they will have

cleaned up your feed and are acting like old stagers. If so, give them another light scattering. You want to get them all to eating and drinking as fast as ever you can. Some of them will still stand around and "chup," and will go to sleep that way, without taking feed or water the first day. They will cry at intervals throughout the night. If you are patient and wish to bother with it, find the owner of the voice you hear and give him a drink. The writer has gotten out of bed many a time because he could not stand the crying voices and after making a few chaps happy with a drink has in all probability not only saved chicks from starvation but made his own night more comfortable. This is the "personal element" we hear so much about in connection with the conduct of any line of business, like the storekeeper who goes to the store especially to accommodate some good customer.

Should your chicks arrive in the morning, so that they have had their first feed and water before noon, leave them until about 2 o'clock; at that hour give them another light scattering of feed and tilt the water fountains again so that the water is up to the edge of the saucer. Keep the water at as high a level in the saucer as you can throughout the day. At 4 o'clock give them another feed and at this time replenish the fountains, using water from which the chill has been taken (by adding a little hot water). The easiest way to refill the fountains is to carry in two buckets, one filled with water, the other empty. Empty the fountain into the second bucket, then dip it into the fresh bucket, fit the saucer over it, reverse it, and set it down. You will have to move very cautiously, "feeling your way" amongst the chicks with your



foot and with your foot pushing aside any that happen to be in your way. You will learn this trick quickly. While in the ring, and later when you have turned them loose in the house, make it a practice to keep your feet as close to the floor as you can.

If you are just starting in the business you will very likely have someone coming in to see your new chicks. Put a sign on the outside of the door reading "Be quiet;" and if you take anyone into the brooder house, caution them to be quiet. When the chicks are just hatched noises will not bother them so much but when they are a few days old and thereafter it will be a very harmful influence to have someone come up to the house (or into it) and clap their hands and shout for joy at the sight. The little chaps will drop in their tracks or dash wildly for cover; and anything of the sort will cost you money because a sudden nervous shock hurts any tender, nervous organization. The more vigorous they are the more nervous they will be. This is not so noticeable when they are segregated into small lots, but where they are kept in swarms as we keep them it stands out boldly. You will learn it for yourself but guard against it if you can.

The 4 o'clock feed is the last for the first day. Leave them until 5 (if early in the season), until 6 if later, but not until dark. The curtains should be raised before the 4 o'clock feed if the day is short, so they will have plenty of light for the final feed. If the day is longer the curtains remain down. An hour after the last feed the water pots are removed; set them outside the circle. Then pick up the tar paper. Brush off any chicks standing on it and put the paper outside the circle. Pile up the differ-

ent pieces, saving what feed remains on them. Scatter this in the litter outside the ring or leave it for the morning feed, whichever is easiest for you. It is better not to scatter it inside the ring where they will sleep on it.

Then let the chicks settle down. If after half an hour or so, when they have begun to settle, they show an inclination to crowd toward the stove, increase the heat by turning the upper screw of the regulator, but do it slowly. You want them to stay at least two feet away from the legs of the stove. As darkness comes on they will miss their mother. There will be a great deal of crying and they will "cuddle" toward one another, trying to "get under." You will simply have to grin and bear this. They will finally settle down, very close to each other. They may favor one side or the other, bunching up; if so, spread them around the stove by pushing a bunch along the straw. You may have to take a handful here and there and remove it bodily to another section. When they are a few days older they will find the right degree in the circle; and very often even the newly hatched will spread round the stove in a perfect circle.

Should the main body crowd the outer edge of the wire circle, the temperature is too high and it should be reduced by turning down the stove. Only on warm nights will it be necessary to increase the air supply by opening the inlet shaft more than an inch or so and the outlet shaft by three inches (on the bottom slide). You can gauge this by your own sensation while in the room. The air should be sweet but not cool. And remember that the feeling you have while standing upright is no guide—your face may feel hot and close but the chicks are far

from the atmosphere you are "tasting." The fresh air is on the floor and the greatest heat is near the roof—you must get down to the level of the chicks before your judgment can be taken. If your thermometer reads between 90 and 95 and the chicks are settled with the outer ones near the thermometer, your heat is about right; and if you do not feel a "stuffiness" in the air when you get your face down near the thermometer, your air is about right.

We usually look in on the chicks at about 7 o'clock and again just before going to bed. Newly hatched, they should now look like a big omelette, close together, many with their necks stretched flat along the straw; but they should not be piled three or four deep. If they are so piled up and are the proper distance from the stove there is too much air. Correct this by reducing the opening in the air shafts. Before leaving the house on the last round, test the alarm system by pressing the contact points together first on one side, then the other. The bell in the house should ring each time.

We leave the curtains down at night for the first few nights. Thereafter it is raised after dark.

### Second Day

On the second day raise the curtains as soon after daylight as possible. Put down the tar paper plats, scattering the grain on them as you go. This will be rather a tedious process on this day because they have not yet learned that it means "eat." Next day it will go easier. When they have had the feed about half an hour put in the water pots. Temper the water to the heat of your hand and add a level teaspoonful of common baking soda to each quart of water. (Use the two-bucket scheme for

emptying and refilling the pots). This is done to overcome possible fermentation in the little crops, as yet unused to "outside" feedstuffs. Leave them with their feed and water for about an hour. Then roll up the circle and set it aside. If you have the space above the rafter braces, make a place for it up there; otherwise provide a bracket of some kind on the wall on which to hang it. Don't set it in a corner—it looks like mother to them and they are likely to crowd up around it during the day.

If the day opens bright and clear drop the curtains; if it is cloudy leave them up so as to have all light possible. Increase the ventilation by opening the air shafts wider—at least double the opening used during the night. On very warm days you may have to open one or more windows toward noon. Keep the air fresh and pure. There is no danger of overdoing the ventilation during the day—the night is the danger period in this respect. You should give them all the air possible during the day. Keep the temperature up; they can get away from the heat in the ends of the house.

Scatter a light feed of the oats, wheat and corn on the plats every three hours; leave the plats in place on the second day so that the slower ones may yet have a chance to catch on. We make it a point to so regulate the quantity that there will be a little left on the plats an hour after feeding. Empty and refill the water pots at 11 o'clock and again at 3, but omit the soda after the first filling; and scatter the pots pretty well all over the room. If the chicks favor a certain portion of the house, put several pots in the vicinity. Take the chill off the water at each filling.

When bed time comes you will have some trouble in rounding up the herd on this second night. Fasten one end of the wire to the wall near the stove and unrolling it as you go, round the little fellows ahead of you. In a day or two they will keep well ahead and it will be but a few minutes work to put the circle in place. Stay on the outside of the circle as you unroll it. You will likely have to reduce the temperature a point or two on this night to keep them the proper distance from the stove. Do not overlook reducing the openings of the airshafts. Get them back to the position at which you had them the night before. Test the alarm system same as you did last night.

### Third Day

On the third day feed and water early in the morning as before; but do not use the soda. Remember to take the chill off the water. Leave them in the circle for half an hour, then remove the circle and pile up the plats, scattering the left-over grain (if any) in the litter.

At 9 or 9:30 on the third day we give them dry bran and charcoal. The bran must be absolutely pure and sweet—if it tastes bitter we do not use it. To a sack of bran (80 or 90 lbs.) we add about 8 pounds of fine charcoal. This is fed in little troughs.

The trough is made of a piece of  $\frac{1}{2} \times 3$ , in 4 foot lengths, on each side of which is nailed an ordinary lath. The end pieces are 3 inches high and a lath is nailed across the top from one end piece to the other, with a little support in the center of just the right size to keep the top piece from sagging. We use one trough to each hundred chicks. The troughs are set lengthwise of the house close

to the end walls, nine of them near the closed end and five in the end where the door is. If many chicks are working near the stove we transfer one or two troughs from each end to the side walls until they have learned to follow them. In this as well as in every other respect you will note that we go to extra trouble to get the little fellows started.

We find it easier to fill the troughs the first day or two near the door and to carry them into place already filled. We use five gallon oil cans for feed pails. The top is cut out to within an inch of the edge. This one inch is turned over, making the top stronger. Heavy wire is used for a bale; we fasten the bale toward one side rather than in the center. This makes it convenient to carry two pails in one hand which saves steps as two pails full of bran can be carried as easily as one.

The troughs are filled with a small-mouthed scoop or a large sized flat stove shovel. Enough bran is put into each trough to bring it within half an inch of the top of the side pieces. If the trough is filled level full there will be too much waste—there will be some in any event, especially for the first few days as some of the little fellows will crawl into almost any sized opening. We have found that a trough of the exact dimensions given is least wasteful.

The bran troughs are removed at about 11:30. We fasten two brackets to each end wall, not quite four feet apart and about two feet wide, and the troughs are set on the brackets. The top piece of the trough being flat and wide, the troughs will "stack" nicely. The water pots are then refilled and the plats are put down, most of them

where the troughs have been but at least two on each side of the stove. A liberal scattering of grain is spread on them and this remains in place for about half an hour. The quantity can be gauged only by experimenting. Measure it in scoopfuls and if they leave part of it, reduce it next time; if they clean it up in less time, increase it. At the end of half an hour the plats are piled up again and the troughs are replaced. If any are empty they are refilled; but they must be cleaned up before more is added.

At 3 o'clock the water is freshened again and the troughs are removed. Grain is fed at 4 and the plats remain in place until bedtime. If the grain is cleaned up entirely within a short time a little more is scattered, but it must be cleaned up quickly and completely before this is done. The circle is put into place as before, the ventilation is adjusted and the alarm is tested.

#### Fourth Day

The same routine is followed on the 4th day. At this stage it usually becomes necessary to begin reducing the temperature. The location of the chicks within the circle after they have settled down is the best guide to follow in reducing the temperature. It should be done gradually, one or two degrees at most. The 7 o'clock inspection trip is the best time; then in looking in again just before retiring a re-adjustment can be made if necessary.

#### Fifth and Sixth Days

On the fifth day chick mash replaces the bran and green stuff is fed at noon in place of the grain. The simplest way of handling the chick mash problem is to



ONE OF THE BROODER HOUSES ON THE TUMBACH EGG FARM



use equal parts of bran and hen mash, with the addition of 100 pounds of bone meal to each completed ton, and this is not only a simple method but it continues the heavy feeding of bran on which we place great reliance. The formula of hen mash will be found in the chapter devoted to feeding the layers. At this stage we begin to weigh the feed with the idea of keeping the chicks on half mash and half grain (by weight). A quantity of grain is weighed into a pail in the morning, likewise a quantity of mash into other pails. This is used for the day's feeding. In the evening the remainder is weighed and the results indicate the course to be followed next day. If your memory is not good, mark the results on a card fastened to the wall in the feedhouse.

The chicks will be slow to take the green stuff at first. We use the plats, to which they have become accustomed. Very little will be needed at first, but in a short time they will take to it and then they are given all they will eat. The plats can then be omitted. When they have learned to eat the greens readily it will not be necessary to remove the troughs at noon. They can be left in place all day.

#### Seventh to Eleventh Days

On the 7th day the grain is fed in the morning without using the plats; but they are used for the evening feed. At this stage it will be necessary to use a higher and wider netting for the circle; we use one 2 feet high and long enough to make an oval reaching from side to side of the house and about 18 feet at the longest point. It is covered with muslin like the other. To support the wire, cords are fastened to the roof with a hook on the

end of each. When the wire is unrolled the hooks are fastened as they are passed. The ventilation will have to be increased; this is done by increasing the openings in both inlet and outlet shafts. The chicks are likely now to be settling nearer the wire, but this is of no consequence.

If the litter is beginning to look bare in spots, add another inch or two.

The water pots are now set on little platforms. These are made of half inch pieces about one foot square nailed to blocks three inches high. They are set close together, about five feet from the stove, half on each side of it; at the noon filling they are set further back. The water is no longer tempered from this time on unless freezing weather prevails. The pots, platforms and all, are set back still farther when the wire is put up at night and when the wire is in place one or two pots are set inside of it, close to the stove, for the benefit of any chaps that may have overlooked their bed time drink. When the last inspection is made at night all of the pots are returned to their place inside the wire. This gives them water early in the morning, tempered, and at breakfast time they will be found busily scratching.

#### Twelfth to Twentieth Days

On the 12th day more straw is added to the litter. If baled straw is available save out several chunks of it. Use these to bank up the corners, stuffing loose straw behind them to avoid a nice crawling-in place in which you would most likely find several hundred stacked up and smothered.

A strip of muslin is now tacked to the rear wall, extending to the floor. The wire, instead of forming an oval, is used running from one end wall to the other; one end is fastened just inside the outlet airshaft, the other end on the inlet shaft. It bulges out in the center where it goes around the stove. It is upheld by the cords and hooks which are changed to conform with the new position. The idea is to herd the chicks toward the back wall, where the roosts will be. The muslin on the back wall is a big help. It still looks like "mother." The temperature is increased for the night at this stage as the chicks will be farther from the stove. Some lots will require a bit of herding when this change is made, but ordinarily they take to it readily enough after one or two evenings.

On the 14th day the roosts are let down in the morning before the troughs are put in place; the troughs are set in double rows beyond the roosts with one or two on top of them, set between the cross bars. This helps to get the chicks upstairs. The roosts are raised when the evening grain is fed.

On the 18th day larger troughs are used. These are made of  $\frac{1}{2} \times 4$ , 6 feet long, for the bottom, with two pieces of  $\frac{1}{2} \times 2$  for the sides, and the top is of  $\frac{1}{2} \times 2$ , the end pieces being 4 inches high. Larger water pots are used (4 or 5 quart) and fewer of them.

### Three Weeks and Thereafter

At 3 weeks the morning grain feed is omitted and sprouted oats are fed at from 9 to 10 o'clock. The oats is not allowed to sprout into a matted mass but is used when the white roots are about half an inch long. The

chicks take to this readily. Enough is fed to last them about 15 minutes. It is fed in the litter. At this time we begin adding coarse grain to the evening feed, mixing it with the chick grain in gradually increasing quantities until the chick grain is entirely replaced at about 7 weeks.

We use the same grain for the chicks as we do for the layers excepting that we never give them barley with the hulls on it.

A pan of medium shell and medium granite grit is also given them at this stage and is kept before them constantly.

At four weeks the roosts are let down permanently. Some time after the evening grain feed has been cleaned up, but before the chicks begin to settle down behind the wire, we raise the end roosts and kick the straw into the corners, building it up to the height of the roosts. This prevents corner-crowding and is also an encouragement toward climbing up on the roosts.

We usually clean out the brooder house and put in fresh straw the day before the roosts are to be lowered permanently.

If warm nights prevail at from 3 to 4 weeks it may be necessary to temporarily increase the ventilation when the chicks begin to settle down. We do this by opening the upper slide of the outlet shaft about an inch. It is left open until the 7 o'clock inspection at which time, if the night air is cool, it is closed again.

If the night air is warm it may be necessary to leave a slight opening in this upper slide all night. You can tell by the chicks whether or not it is necessary. If they are

lying close together in the straw, (such as are not on the roosts), or if those that climbed up have dropped off, the upper slide may remain closed.

If they are uncomfortably warm they will lie far apart, some with open mouths. It seldom happens that the upper slide must be left open all night (at this stage) with early hatches; the March hatches may require it. We have even found it necessary during a very hot spell to put in a screen door at their bedtime, leaving the main door wide open, until our own bedtime. In this case the front windows are also left open. The chicks being against the back wall they are in no danger from drafts.

As soon as the chicks have become accustomed to the roosts being left down, usually in two or three days, the use of the wire is discontinued and the muslin on the back wall is removed.

### Use of the Yards

The age when the chicks may be permitted outdoors is dependent entirely on the weather. January hatches are seldom turned out before they are 10 days old and then only on clear, warm days. We leave them out but a short time at first, herding them back into the house until they grow accustomed to running in and out. We use a sloping runway, made of boards, as wide as the doorway, to make it easy for them to go back and forth. Care is used to keep the space between the runway and the fence filled with dirt so the chicks cannot pack up in this space; and we also bank the corners of the yard with dirt to prevent crowding.

If the yard is in growing green stuff we cut it with a lawn mower before the chicks are turned out. The out-

side water pot is not used until the chicks have been outdoors off and on for at least a week. This keeps them running into the warm house for water.

Half of the mash troughs are brought into the yard from the house as soon as the weather permits, but on the January hatches this is seldom done before three weeks.

The March hatches are let out earlier and they have their outside water pot and mash troughs earlier also. Common sense will dictate the course to be followed in respect to these matters. **Our rule is to take no chances on exposure to inclement weather.** If a cold wind or driving rain sets in while the chicks are outdoors, when they are less than four or five weeks old, we take the trouble to herd them in. It is a bit troublesome at first, but they soon learn your purpose; and in a short time your appearance in the yard along with a sudden drop in temperature or a heavy rain will be a signal to "scoot."

The second division of the yard is opened as soon as an appreciable number of the chicks begin to fly over the little division fence. We do not cut the green stuff in the second yard—they are allowed to mow it themselves. The feeding of green stuff inside the house is not discontinued when the chicks are turned outdoors.

If the weather is favorable at about 4 weeks, half of the sprouted oats and half of the evening grain is fed outdoors from that time on.

With the late hatches care is taken to keep the first division of the yard from getting dusty; it is wet down regularly.

At from 5 to 6 weeks the cockerels are taken out; but before entering on this phase of the work the description

will be interrupted to discuss possible troubles that may have been encountered meantime.

### Chick Troubles and Diseases

The reader, especially the novice, might assume from the description given that we still have all the chicks that we counted out of the boxes. If such were the case there would be no money in egg-farming—it would be too easy to be profitable.

We count on raising to the broiler and egg-laying stages about 80 per cent of the chicks hatched. Judging by what you read in descriptions of brooding appliances this may seem startling to you. And to the experienced man who uses another method it may seem that we do a lot of unnecessary work and spend a lot of time to get such poor (?) results. To the latter might be given the reminder that we are dealing with 1500 chicks all the time—if we had to do all these things in twenty or thirty different compartments, opening and closing that many gates for each operation, we would never “arrive.” As a matter of fact the writer can easily handle from 4,500 to 5,000 chicks single handed and alone on the plan herein given; and he not only can do it but he does and he handles a lot of other work along with it.

The percentage of chicks raised is based on a year after year average and handling from five to six lots each season. In good seasons we do far better—we had one lot of 1,650 this year (1919) out of which the total brooder house mortality was only 85 chicks. This is the best record we ever made with such a large lot. It is not safe to count on doing that well one year with another in

large lots. A greater percentage could probably be raised if the chicks are brooded in small lots; but one man could not handle so many. We prefer making a big showing of matured birds to a higher percentage and fewer of them.

We count on half pullets and half cockerels. This too will vary with different seasons but half and half is a fair average.

#### Danger Periods

There are three distinct periods in the growth of chicks when they seem more susceptible to weakness and all are related to the process of feathering. The first stage is when they are two or three days out of the incubator. They are sprouting wing and tail feathers at this time. Some will go down under the strain, others will fall behind the flock in development and as a rule will never catch up. The second period, at from 10 to 14 days, is marked by the coming in of the feathers on the crop, on the back and on the neck; and the final period (in the chick stage) is when the feathers come in on the head, usually at from 5 to 7 weeks.

Mention is made of these periods because we keep a careful eye on the chicks at that time. They always look ragged and rather hopeless when the head feathers are coming. We never allow them to suffer from exposure at such times. If they do not seem normally active we give them a tonic for two or three days. We use the Douglas Mixture in the water, at the rate of a teaspoonful to a quart of water. This is put into the water at the morning renewal; the afternoon water is given clear. The formula will be given elsewhere—consult the index.



### Diseases

Some chicks will die off for no apparent reason—they are simply found dead, apparently in perfect condition excepting for that sad fact. Experts find reasons for it—in practice we have no explanation. You may safely count on finding one of these every now and again; but if you find them dead in bunches, plump bodies, fine looking little chaps, look to your feed. Is your grain sound and sweet? If it is not fit for you to eat it is not fit for your chicks. And your bran—is it sweet and pure? Or do you find lumps of it tinged with greenish mould? Have you spilt water in the litter and allowed the soggy mass to remain, tainting the grain and waste mash, to be found and eaten by the little fellows looking for variety? Are you giving them partially decayed vegetable tops, or fermented table scraps? Is the meat in the mash faulty? Did you leave them exposed to a sudden chilling rain?

Nine times in ten the reason for numerous sudden deaths will be found in this list. If you find the fault, give the whole flock a dose of salts next morning, common Epsom Salts, a tablespoonful to a gallon of water (dissolve it in hot water and add to your pail) in mild cases, double the dose if the attack is severe. Give them fresh water in the afternoon, and follow with the Douglas Mixture, as already directed, the next two days.

You may have some leg weakness—sturdy chicks getting down on their knees. Once more the scientists give us the cause but we admit our ignorance. We have seen it with all kinds of brooding methods and with various feeding systems. We do not know the cause nor the proper remedy. If the attack is a severe one we assume

that a thorough cleansing and disinfecting of the intestinal tract cannot be harmful and we give them the salts and tonic. Our experience is that the greater number get over it. We segregate those affected, putting them in a large wire covered box, not too near the stove, until they get their legs again.

“Puffy crops” is another common trouble. You will see chicks here and there, early in the morning, with bloated crops which on examination are found to be air-filled. An isolated case can be treated with a bit of common soda, dissolved in water and poured down the throat. If numerous cases develop give the whole lot a dose of soda (as already described), adding a heaping teaspoonful of ground ginger to two or three gallons of water; give this two mornings in succession.

Toe-picking is often encountered. The cause has been ascribed to almost everything under the sun, from lack of meat to an injured toe suffered by the great grandfather. We think it is started by a nervous condition due generally to excessive heat and lack of air, either in the incubator (after hatching), on the road home, or in the brooder house. Once started it is hard to control. At the first sign we make sure there is plenty of fresh air in the house and that the temperature is not too high. Next the windows are darkened; and if the light is still very strong the glass can be painted over with whitewash into which a little lampblack or some blueing is added. Then a special effort is made to keep the chicks busy—rake the litter into piles at intervals; they will try to scratch them down as fast as you make them. Add a little grain to each pile. Give them extra greens. Hang

bunches of lettuce against the walls—anything that will divert them. This is the best treatment we know of. The chaps that have been attacked must be segregated in a box or something of the kind. As long as bloody toes are in evidence they will keep at it.

#### White Diarrhoea and Coccidiosis

There remain but two well-recognized troubles to be discussed, and, judging by the quantity of matter written concerning them, these two cause by far the greater mortality amongst chicks: White Diarrhoea and Coccidiosis. The writer has so far been spared experience with either of them, although he has been called on many times for assistance in handling chicks so infected. Whether his having escaped them is due to his method of handling the chicks, either in brooding or in feeding, he is not prepared to say. This work being based entirely on his experience he might very properly avoid the issue, but with the understanding that he is dealing with theories he ventures these opinions, based entirely on observation:

White diarrhoea is most commonly recognized as "pasted-up-behind," which is self-explanatory. The chicks become droopy and listless, stand around humped up, usually crowding together for warmth, and die off in great numbers.

Scientists tell us it is a bacterial disease which may be transmitted from generation to generation and from one chick to another. This sounds rather hopeless; and it may be so. The wonder then is that there are any chickens left what with the interchange that is constantly going on, especially with the growth of the commercial

hatchery business. But we will admit that there is a distinct bacterial disease of the kind. Let us take refuge in the suggestion that what is commonly called white diarrhoea in chicks is not that particular disease. From that standpoint it can safely be discussed.

The writer believes that bowel trouble in young chicks, evidenced by "pasting up," is due primarily to a chilling of the chick while very young and when it is most susceptible to such a shock. And in the light of such a belief it will more readily be understood why he so strongly urges extreme care in handling the chicks. If the reader is sufficiently interested he may turn back the pages and learn how the writer would avoid the trouble, which to his notion is the only hope.

A flock of chicks infected with white diarrhoea is well-nigh a hopeless proposition. The best we can do, all we can hope for, is to save the strongest. We would give them the salts and tonic treatment, the salts once a week, the tonic every other day. Most authorities dwell strongly on the merits of sour milk or buttermilk, kept before them all the time. This must not be given in tin or galvanized iron vessels. The best plan is to scald several of the mash troughs, to make them water tight, and feed it in the troughs.

More important is the matter of avoiding further exposure. If the theory herein advanced, that the trouble is due to chilling, resulting in a cold settling in the intestines; if this theory is correct, we must first of all make certain that the chicks are no longer exposed to chilling. Excepting late in the season they had perhaps best be kept in the house for a week or two, where the air is kept

not only fresh and pure but tempered with warmth all over the room, and in addition, a zone of extra warmth may be found close to the stove for those needing it. The objection to letting them outdoors is that the stronger ones, those able to withstand possible severe changes in temperature, will always "scoot" out, and the weaker ones that need a tempered atmosphere will run with them as long as they can, finally bunching up where they are still in sight of the fellows who are enjoying themselves.

A change in the feeding method is also advisable. Let them have their grain and greens as before, but abandon the dry mash feeding and substitute a moistened mash, fed twice a day say at 10 a. m. and 3 p. m. If milk of any kind is available, use it to moisten the mash, not a wet, soggy mass, but a crumbly mixture, one that when balled up in the hand will fall apart readily when the pressure is removed. The addition of finely chopped onions or garlic and stale bread, the latter previously soaked in milk or warm water, would be a decided benefit. Feed the grain sparingly and use the plats regardless of age, but in addition scatter some grain promiscuously through the litter.

It would also seem advisable to clean the brooder house once a week while the trouble is running, putting in fresh straw at each cleaning. Keep the temperature up, especially at night. Keep it high enough so that they will spread out. If the roosts have been let down, put them up again and resume the use of the wire circle, enlarging it sufficiently so that the stronger chicks can get away from the increased heat. Watch the ventilation carefully; give them plenty of fresh air at night, but do it

through the air shafts rather than with open windows. Keep the windows open during the day, and if the days are uncomfortably warm, use a screen door on the main doorway.

The writer believes that when you have done all this, you have done everything possible and that you will save the livable chicks. You may feed some of the many kinds of "dope" offered in the market if you wish—we never use any ; but we have not been driven to it, perhaps. Whether you use "dope" or not, give the chicks the care herein outlined; they need it.

**Coccidiosis** looks as formidable in action as it does in print. It is said to be an infection of the Caeca, sometimes called the Appendix or Blind Gut. The only cases that have come to the writer's observation have been in chicks that were from 6 to 8 weeks old. The outstanding symptom is the passing of a bloody mucus in the droppings. The birds go down very fast and the mortality is extremely heavy. Bichloride of Mercury has been used successfully in treating this disease. The preparation with instructions for use may be had from the Poultrymen's Co-operative Milling Association of Los Angeles.

### Don't Worry

Should the reader be new at the work, let him beware of too much pondering over what has herein been related as to chick troubles; and more particularly let him beware of studying too closely the booklets and circulars that will come to him concerning diseases of chicks.

Too many people are influenced by these lurid descriptions; they immediately see all of the many symptoms de-

scribed, and proceed at once to dose and doctor the imaginary ills.

One of the most successful small operators the writer knows, a man who has brooded twelve to fifteen hundred chicks each year for a number of years, has never had trouble of any kind excepting toe-picking; and while the writer has not been present every minute of the time yet he is morally certain that this man has never fed or used an ounce of "dope" of any kind. But he lives with his chicks. If they are outdoors when young and a sudden cold wind comes up, he drops whatever he may be doing and puts his chicks inside. Constant care and thought for the welfare of those chicks is the only panacea he knows; and in the writer's estimation his is the best remedy.

The fact that he raises a larger percentage of his chicks than we do would tend to prove, to us at least, that his greater care shows up in his better results.

Let that be your main reliance; look after your chicks carefully and methodically. And should trouble come to you in spite of it, check back your work (as an accountant would say)—try and find the point wherein you failed to properly protect them, and the finding of the error will be its own best remedy. Make up for it by extra care as has herein been outlined; your chances of overcoming the trouble will be far better if you follow some such method than if you try to make the correction by dosing and doping. The latter method is like unto a mother whose baby cries because of a loose pin and who quiets it with some "doped" soothing syrup while the pin remains. If you fail to go over your work and locate the cause of

the trouble you have learnt nothing from the experience.

And don't get "rattled." You'll forget to fill the fuel tank or set the house afire if you lose your head. You cannot expect your chicks that have been drooping to show up in fine mettle the day after you have removed some rotten feed or closed the door you left open the night before or restored the supply of fresh air which you accidentally shut off. Give nature a chance to repair the damage, with such help as you are giving her in the way of extra care and special feeding.

### **Lice and Mite Troubles**

We have never had lice on young chicks hatched in an incubator and brooded artificially excepting during our second year in the work when we made the serious mistake of mixing hen-hatched chicks with those hatched in the incubators. This nearly ruined the whole year's work. Since then we take special precautions to see that neither hen-hatched chicks nor old fowls gain access to the brooder houses and yards, nor are any such allowed the freedom of the place in the enjoyment of which they might wander near the brooder yards.

You will have no mites in the brooder house if you spray the house in advance as we do ours.

### **Cleaning and Spraying the Brooder Houses**

We clean and spray the brooder houses just once during the brooding stage. This is done at about 4 weeks, when the roosts are let down permanently. When the January chicks are taken out the house is cleaned and sprayed before the next brood comes on. When the



March chicks are carried in the brooder houses beyond the 6 to 8 weeks' stage the house is cleaned every ten days and is sprayed once a month.

### **Training the Family Cat**

It is an easy matter to train a cat to leave the chicks alone if the matter is gone about properly. If there are young cats on the place when chicks come in they are taken to the brooder house, in among the chicks, are given the "smell" of a chick along with a reasonable cuffing. This is repeated several times and thereafter they usually give the brooder houses a wide berth. If they are found nosing around the brooder house afterward we make a point of having a pail of water handy and if the cat can be given one good drenching the lesson is learned. Should a cat be caught in the house or yard with a chick we drench it in a barrel; if the chick is dead we force it into its mouth for the drenching and then hang it around the cat's neck for a time.

Old cats are harder to train but with patience it can be done. We have a mother cat on the place now who has been found time and again watching a gopher hole in a brooder yard with chicks all around her; and we have watched her take her kittens to the brooder yard fence, evidently to show them the chicks, and when they showed interest she would cuff them just as we did her. The farm is a sort of repository for stray cats.

### **Buying Partly Developed Chicks**

At times an opportunity presents itself to purchase partly grown chicks. If your brooding has not been suc-

cessful or if you could handle more young stock than you have this might be worth while. But great care must be exercised or your last state will be worse than your first. If it is at all possible it would be better to keep the new lot entirely separate from your own. If this is not practicable you must be sure that the birds are not coming from a place where disease has been rampant and that the chicks are not infested with lice. It seldom pays to buy a run down lot that someone has failed with—you are only risking your own.

Under no circumstances should hen-brooded chicks be mixed with incubator lots; this applies no matter how clean of lice they may seem to be. The possible gain is not worth the risk. If you can't keep the hen-hatched lot separate from the others do not buy or take them.

### **Taking Out the Cockerels**

We take out the cockerels at from 5 to 6 weeks—those that are easily distinguished. They can usually be selected by their combs and shape, but the selection at that age is more or less guesswork, especially for a novice. Take out only those of which you are reasonably certain, and as others show up, take them out. Keep cockerels with the pullets rather than to put pullets with the cockerels.

They are put into the cockerel house which has been heavily bedded down with straw under the roosts, a narrow board being tacked to the edge of the roosts to keep most of the straw in place. If the weather is bad they are kept indoors; but in any event they are not let out until toward noon of the day after they are moved.

Water and feed is provided in the house until they are turned loose in the early morning.

We put 250 cockerels into each 9x10 compartment of the house. The first few evenings we make sure that the straw is banked up in the corners under the roosts so they cannot crowd and pile up; they must be watched in this respect for several nights, until they resume their roosting.

The further treatment of the cockerels will be discussed in a separate chapter.

### **Continuing the Brooder House Work**

Taking out the cockerels makes room in the brooder house and gives the remainder a better chance. If the weather is bad it may be necessary to slightly increase the stove heat to make up for the body heat lost by the removal of so many of the flock.

No change is made in the feed or the method of handling the chicks, excepting that the gradual change from chick size to coarse grain is continued until at 7 weeks the fine grain is entirely replaced. The January pullets are taken from the brooder house at from 7 to 8 weeks, dependent on the weather. If the weather is good we take them out at 7, otherwise they remain until 8. The March pullets remain in the brooder house longer, as we do not have room for them until the summer re-arrangement of the laying hens is made. If the room is available they can be removed even earlier than the January lot. We put in higher roosts (in the brooder houses) at 8 or 9 weeks, spacing them 8 or 10 inches apart and about 18 inches from the floor.

The stove is turned off at about 7 weeks, (this applies to the March hatches), this depending again on the weather. They need but little artificial heat at night in normal weather after 6 weeks. We taper it off gradually, also increasing the fresh air supply by using the upper slide on the outlet shaft.

When they are comfortable at night without the stove we start the stove in the morning before turning them outdoors and run it until they have been outdoors and in again for a "warming-up" after tasting the outdoor air. If the day is cloudy or chilly the stove is run all day, turned low; and at the last feed time it is turned up until they have settled down for the night when it is again turned off. This continued use of artificial heat is necessary because the house is a large one and there is little chance for the body heat of the birds to afford any reasonable degree of heat to the comparatively few birds who may need it during the day and who come indoors to find it.

The third division of the yard is opened to the March pullets at about 8 weeks.

### **Taking the Pullets From the Brooder House**

We put the January pullets directly into the laying house. The yards have meantime been ploughed and planted to barley which may be 12 to 18 inches high when they are moved. We put up a temporary fence of 1½-inch mesh netting, enclosing a space the width of the house space to be used and about 25 feet deep. This makes it easier to train them to the new housing place and also saves trampling of the green barley. If we

need it we mow the barley in the remainder of the yard—it will grow up again very fast at that time of the year.

In moving the pullets care must be exercised or some will be injured. They are nervous and flighty when their regular routine is interrupted and when they are shut in the house and some are being picked up and put into crates the others are liable to pile up in the corners, some being smothered. The best plan is to let a large part of the flock pass outdoors, keeping one or two hundred inside. A panel of wire, 2 feet high and 5 feet long, covered with burlap and set diagonally in one corner of the house, makes a good catching place. A few can be driven into it at a time. Meantime we keep an eye out for a possible piling-up of the others—if they are crowding into the other corners we stir them up before going to work on the lot behind the panel.

Never crowd the youngsters in the crates when moving them. A little more time spent at it is a good investment. We always put them directly into the house rather than in the yard. It saves a lot of time, work and worry in the evening; they are determined to get back to their old roosting quarters. This is obviated if they are carried directly into the new house and are kept indoors at least until the next day.

We put the whole lot from a brooder house into a fifty-foot compartment of the laying house—usually six or seven hundred. A special set of roosts is put into place under the dropping boards. These roosts are made of  $\frac{1}{2}$ x2 stuff, set 6 inches apart on cross bars of 1x3, 5 feet long. They are hinged to the back wall about 12 inches

from the concrete floor with supports under the center and near the front end. Two sections of roosts are used, each about 6 feet long. This leaves a clear space between the two sections. The floor is bedded down heavily with straw; near the back wall the straw is packed in until it is flush with the roosts. We usually line the back wall with chunks from the bales and pile loose straw on top of these. The purpose is to prevent a piling up under the roosts which is likely to occur the first night or two. Chicks seldom take to the roosts immediately when they have been moved, even though they have been roosting.

We keep them in the house for a full day after moving them to let them get acquainted with the new quarters; and if the weather is bad they are kept indoors several days. An exposure to severe weather is extremely bad policy just after moving a lot of young birds; they are nervous and excited at best and are far more susceptible to adverse influences.

The awning is dropped at night; and if it is very cold (or wet and cold), we hang a burlap curtain from the dropboard reaching to within 8 or 10 inches of the floor. We make it a point to be with them at bedtime the first night; they have come to know us, and in their strange quarters it seems to have a quieting effect to be around. We look in on them at the 7 o'clock round; if the curtain was dropped and they seem to be too warm it is partially or completely raised—as seems best. We look in again just before our own bedtime and make such readjustment as may be necessary. This extra watchfulness is not necessary after a few nights, when they have grown accustomed to the new place.

The main feed troughs are cut off, either by removal (the covers being hung to the outside wall), or by tacking a piece of  $\frac{1}{2} \times 3$  stuff in the openings both inside and out. The mash is fed in troughs made of a 6-inch bottom with  $\frac{1}{2} \times 4$  pieces for the sides, end pieces 6 inches high, and a piece of  $1 \times 4$  across the top. Troughs are set both in and outside the house. Troughs of this same size are used for the March pullets in the brooder houses at from 7 to 8 weeks, and also for the cockerels when they reach that age. It is advisable to continue the use of two or three of the smaller sized troughs for a few days after the change is made—this applies at all stages.

The regular house water pots are used after a few days. It is good practice to set one or two of the old style fountains inside the house, on platforms, just after the birds are moved. The pots are cleaned with a brush every day.

The feed is continued as before. The pan or box of shell and grit must not be overlooked.

When cockerels are spotted they are picked up promptly and removed to the cockerel house.

As soon as an appreciable number, say half, of the birds are found on the dropboard roosts at night—if they do not take to the dropboard compartments before they begin to look crowded underneath—the lower section is closed off and all are forced into the upper section. This is accomplished by the use of a set of sloping lath ladders set tight together, fastened to the front dropboard support by loops of wire hung on nails. The laths are nailed to the supports not more than  $1\frac{1}{2}$  inches apart and the whole set is fitted perfectly both on the edges where the different sections meet and on the floor. Care should be

exercised to have no opening large enough for a bird to slip through. With the use of these ladders no trouble is had in getting the birds to go "upstairs." If a few stay in the straw at the foot of the ladders we do not disturb them—they will go up in a night or two. But we make sure that none lie on the trough steps or in other out-of-the-way places. In a week or ten days the ladders may safely be removed, and the underneath roosts are taken out at the same time. A ladder is left in the center of each 16-foot section.

As soon as the birds attain a proper size so they cannot crawl through the 3-inch openings, the main troughs are put into use; but several of the 6-inch troughs are continued in use for a few days when the change is made.

When the March pullets are put into the laying house (if they are from 10 to 12 weeks old, as they are with us), they are put directly on the dropboards by use of the lath ladders. They are kept indoors two days after moving if the weather permits. They can't be kept indoors that long if it is very warm. The same trough and yard arrangement is made as was made with the January lots. If they are to be moved at the earlier stage, 6 to 8 weeks, it would be necessary to use the same under-the-drop-board roosting arrangement as was used with the January birds.

**Watch the birds carefully when you remove them from the brooder house and do not expose them to chilling weather.** Bear in mind they no longer have a warm room to run to. If they have been turned outdoors and rain or a cold wind comes up better take the time to herd them into the house. They are at one of the susceptible stages



of development and if you let them get soggy wet and chill you will surely have a run of colds. Do not let them outdoors very early in the morning. Give them a chance to have their morning drink and to eat some mash first.

Being able to give the young pullets this extra protection with food, water and scratch quarters available, is what makes the use of laying-house quarters superior to the portable colony house system.

Should colds develop in spite of your care, give them the salts and tonic treatment, the salts one day and the tonic twice, a day apart; if they are 8 weeks old or older, double the dose both of salts and tonic. If the colds continue give them this treatment each week; and in case of a severe attack continue the tonic steadily for a week or ten days.

Should the birds take to piling up at night (under the dropboards), put on the curtain when they go to bed and raise it part ways on your last inspection. The curtain makes of the compartment what is practically a closed box and several hundred birds in it will develop a great deal of heat in a very short time. The opening at the bottom of the curtain will allow a sufficient supply of fresh air for an hour or two. **But there will not be sufficient air for the whole night.** The closed curtain is used simply to warm up the compartment as quickly as possible; and warming it up quickly will induce them to spread out before they sweat.

The January pullets are kept on the chick mash until they are at least 4 months old; and if they are well developed and many full-blown combs are in evidence at

that time, the chick mash is continued until 5 months. Regular laying mash is then substituted.

The March pullets are given the laying mash at from 10 to 12 weeks, depending on the weather and their development. If they have grown fast and cool weather has prevailed (which has a tendency to stimulate growth and development) they are continued on the chick mash until 12 weeks; but if it has been hot at intervals (or steadily) the birds will be slower, and they are then given the heavier mash at 10 weeks.

### Culling the Pullets

We have learned by experience and by observation to go very slow on discarding and selling so-called "cull" pullets. One can run up their production per bird by making a close culling, taking out and getting rid of all the undeveloped birds at from 4 to 5 months; but we are not so certain that it is a profitable thing to do. For several years we culled them in this manner; but instead of getting rid of the culls we kept them in a separate pen, and by far the larger part of these "culls" were afterwards retained. One such lot, taken from March hatches, outlayed the main flock throughout the high priced egg season, and never did we find we would be warranted in disposing of the entire lot.

A case of mistaken culling that came directly to the writer's notice was one where a friend of his bought 75 cull pullets from a dealer who obtained them from one of the large egg-farms; they were bought on the writer's advice. The purchaser knew how to handle chickens. This particular lot came into laying within two weeks

of the time he got them and they made a flock average of better than 170 eggs in their first year—which is rather good for culls, especially since only one of the birds was discarded.

We take out none but the plainest sort of culls—birds that are far undersized, scraggly, thin, draggy specimens. Anyone can spot these. They are usually an eyesore in the flock. Others that are lagging in development we segregate and keep to themselves for a few weeks, feeding them as we feed the broiler cockerels. This will bring them out if there is anything to bring out. If they do not respond to it we get rid of them. We think this plan is well worth following.

These slower birds may not equal the high-laying record; but if they pay their feed and as little as 50c profit per bird we have made money by the transaction. If they are constitutionally weak they will go down in the first moult, if we do not cull them out meantime, so they are no detriment to our breeding plans. It would be an easy matter to band them if one wished to be absolutely sure of their proving no detriment.

The matter of culling will be discussed further in a subsequent chapter devoted to that subject.

### **Feeding and Handling the Cockerels**

As our cockerels for breeding are taken from the January hatches we do not force the January lots at the start. They are continued on dry chick mash, with sprouted oats fed at 9 to 10 a. m., and grain in the evening. Green stuff is fed, of course, and a pan of shell and grit is kept in each compartment of the yard. At 8 or 9



COCKEREL-BROILER HOUSE ON THE TUMBACH EGG FARM

weeks we make the first segregation for breeding stock. The best looking, active, vigorous birds, those that stand out in the flock, are put aside, in a separate compartment. At this first segregation we take out about three times the number we are likely to need. These are continued on the same plan of feeding.

The remainder, as well as all of the March cockerels, are forced for broilers. They are given a light feed of grain early in the morning; sprouted oats at about 9; moistened mash at 10 (fed crumbly, not soggy); greens at noon; a light feed of grain at 3 to 4, followed by wet mash within an hour. The quantity of all feed is gauged carefully from day to day, an effort being made to feed just what they will clean up in about ten or fifteen minutes. Ample trough space is provided so that all the birds can find a place. We use the 4-inch troughs at first and change to the 6-inch size as soon as the birds are large enough to eat from them comfortably. We keep them crowded; there is little room to spare either in the house or yard.

They are sold off just as soon as the market will take them. We sell a great many at from  $\frac{3}{4}$  to one pound, and but few are carried to  $1\frac{1}{2}$  pounds excepting when there is a glut in the market and we are compelled to run them up higher. This happens at times—always to our regret. With us it is no question of whether or not it is profitable to feed them for the higher weight. Our object is to get rid of them as soon as we can. We have our hands full, and we think we make more money by giving our available time to the pullets.

A beginner, in his first season, with nothing but the

young chicks on his hands and ample housing space available and ready would be warranted in carrying the broilers long enough to make the 1½-pound weight under the market conditions prevailing in 1918-19. But a Leghorn should not be carried beyond that point. They make the 1½-pound stage more quickly, on the average, than any other breed, but beyond it they fall back by comparison—almost any heavy breed will make the 2-pound stage in less time than a Leghorn will. Furthermore in the ordinary market any other breed is given the preference over a Leghorn at 2 pounds and upward.

There are more culls in the cockerels as a rule, more thin and “wasty” specimens, than among the pullets. These should be segregated and sold as a separate lot and as soon as ever a buyer can be found who will take them. Price is no object. Feeding cull cockerels is about as easy a way to lose money as the writer knows of.

### Marketing Broilers

In marketing a lot of cockerels we make it a rule to grade them by weight, putting the one pounders in one yard, the 1¼ pound in another, and the 1½ pound in still another. It pays to do this. Gauging the weight is a matter of experience. The only way to learn is to have a small family scale for the purpose. Two persons can handle the work to better advantage than one working alone. Shut the first lot in the house, the second lot out of the house. Take the scale into the house along with a short hook. Pick up the largest looking bird, weigh him, clip his tail and turn him loose again. Use him as a sample to guide your further choice. Birds that weigh up can be put into the yard through the slide door; those

under weight can be put into the next compartment through the partition door; and the very small ones should be put into a crate standing outside.

This is the easiest way we know of to make the grading. If a bird is unruly and refuses to lie on the scale, fold the wings, one over the other, passing the joint of one wing clear round the other wing. When you have graded a few hundred in this manner you will soon learn to pick them out without separate weighing, and you can then use a crate in the yard with a platform scale just outside it, weighing six or more at a time.

The grading should be done early in the morning before the birds have filled their crops. This will save you a lot of dissatisfaction in dealing with your buyer. It is useless to try and sell a lot of feed (inside the birds) at broiler prices; and if you are shipping them, while it is good practice to give them some feed before sending them on the journey, to prevent undue shrinkage en route, be sure to allow for the weight of the feed in counting what you are likely to get for them, as it will be dissipated before they reach the marketman; otherwise you will be like the farmer who said of his pig that it did not weigh as much as he thought it would and he did not expect it to.

### Cockerels Intended for Breeders

The cockerels retained for possible breeders are given the use of the large yard as well as the small ones. The large yard has been planted to green stuff previously and they are turned into it. They are continued on chick mash, grain and sprouted oats until they are about 6 months old when hen mash is substituted. Meantime we

pick up any that do not measure up to standard and put them in with the younger broilers for market. This process of elimination is continued until none but the choicest specimens remain. If we have more than we need they are sold for breeding purposes.

They become very troublesome at 4 months of age. There will be a lot of chasing and tearing around. Some will go down in distress and if they are not removed they will be killed. We keep a long-distance ear open at all times and at signs of a specially riotous time we investigate and remove the cause of the trouble. It is death to a hen or pullet that is permitted to remain in the cockerel yards if one should fly the fences.

Some of the birds are likely to be kept in the houses by the bosses and will suffer for food and water. We make it a rule to turn them all out of the house early in the morning, closing the slide doors to keep them out, and leaving the door closed for an hour or two. They are less troublesome in the morning; and in this manner they are sure to get feed and water. In cool weather this can be done again in the evening.

We tried a plan once suggested of keeping a few old cock birds with the young cockerels to act as policeman, putting them in early, while the cockerels were still quite young. This scheme worked beautifully. The old fellows kept the peace and made the youngsters behave, until one bright day the youngsters "rushed" the old fellows and answering the riot call we found the old men down on their knees in different corners; it looked as though a concerted plan had been agreed upon for every single one of the old cocks was utterly whipped.



A brother poultryman recently suggested planting milo maize or egyptian corn in the large yard, putting it in rows close together and sowed thickly. This when grown forms a heavy thicket which would afford protection. We shall try it another season. We welcome and appreciate any suggestion that might lead to easier conditions among the breeding cockerels. It might fairly, truthfully and slangfully be said "they are a tough lot, and the better they are the tougher."

### Housing the Layers

Our laying houses are intended to house 10 birds to the running foot—500 to each 50-foot compartment. If it happens that we have 550 pullets in one brooder house lot we put them into the one compartment. After they begin to lay, when they have become firmly established in their roosting quarters, we open two or even three compartments and yards into one and plant first one yard then another to barley, shutting it off until the green stuff is 6 to 8 inches high. The birds are then turned into it and another section is planted. In this way growing green stuff is had in the yards for the greater part of the season. It is not practicable to grow anything in the yards in our section in July and August; where it can be done it might very profitably be continued throughout the year.

We do not mix birds hatched in different months. The January birds are kept together, likewise those hatched in March. It was the following of such a system that enabled us to determine the relative earnings of birds hatched in different months.

During the late fall, throughout the winter and early in the spring the outside doors of the watershed are closed after the birds have gone to roost; and they are not reopened until 7 or 8 o'clock next morning. During heavy rains they are kept indoors all day.

### Feeding Laying Hens

The layers have dry mash before them at all times. Our standard formula of mash for laying hens follows:

Pure Wheat Bran.....	640 pounds
Wheat Shorts or low grade flour....	320 pounds
Ground Hulled Barley.....	200 pounds
Yellow Feed Meal (Corn meal).....	300 pounds
Croley's High Protein Meat.....	300 pounds
Croley's dried green bone.....	100 pounds
Linseed Oilcake Meal.....	50 pounds
Fine Charcoal .....	50 pounds
Salt—finely sifted .....	20 pounds
<hr/>	
Total mixture.....	1980 pounds

The meat product designated contains 75% of whale meat and 25% fish meal.

The mash is mixed for us at the mill; we supervise the operation. It is put up in 80-pound bags, which we find the most convenient size for handling. It is carried to the troughs in the bags. This has been found an easier and quicker method of handling than by loading on a wheelbarrow or cart which would be hard pushing or pulling through soft ground, and our ground is always soft.

At from 8 to 8:30 A. M. sprouted oats are fed, at the rate of 1 gallon to 100 birds. This is fed in the yards, excepting in very bad weather when it is fed in the litter.

When the oats are fed the mash troughs are looked over and any needing replenishments are looked after when the oats feeding is over. The troughs are filled to within about one inch of the top; if it is run higher than this there will be waste. At intervals the mash remaining in the trough is pulled into one corner with a shovel or a hoe, to prevent its becoming stale. A card record is tacked to the wall in each mash storage place, with a column designated for each compartment of the house. As the mash is carried out it is recorded in the appropriate column. This enables us to determine the weekly mash consumption of each compartment.

Greens are fed either early in the morning or at noon. We use alfalfa or green barley, run through a feed cutter which is driven by a small motor; and for a large part of the year we have a supply of clover lawn clippings.

Coarse shell is kept in a box in the water shed and at intervals coarse granite grit is added to it.

Grain is fed at from 3 to 4 P. M., according to season. The quantity is varied according to mash consumption. We aim to feed half and half of mash and grain, the weight of the dry oats used being counted as grain. The schedule of grain quantities for the different compartments is made up once each week. If a certain compartment has taken 700 pounds of mash during the week that compartment is given 100 pounds of grain daily the week following. This while not absolutely correct is close enough for practical purposes.



REFILLING MASH TROUGHS ON THE TUMBACH EGG FARM

During bad weather when the birds are kept indoors the grain is fed in the litter, otherwise it is fed in the yards. During the dry summer and fall months the yards are wet down thoroughly at regular intervals to avoid dust and its consequent dust-colds and throat irritation. We tried feeding part of the grain in the litter throughout the year but this had to be abandoned. It is impossible in this dry climate to avoid heavy clouds of dust rising when hundreds of birds are feeding and scratching indoors.

During the winter months, when wet, chilly mornings prevail, a light feed of grain is scattered in the litter after the birds have gone to roost. This starts them working early in the morning. The air is usually moist at that season and the dust raised is not heavy enough to be detrimental.

Beginning about September 15th and continuing until about the middle of December the moulting hens are given a special mash feed immediately after the grain is fed. Special low troughs are set in the yards and a small quantity of mash is carried to them in buckets. This mash is wet down lightly with a sprinkling can of water into which Douglas Mixture has been added at the rate of one tablespoonful to each quart of water. A measuring cup is used holding just the proper quantity for a sprinkling can full. Only so much mash is put out as will be cleaned up before the birds go to roost.

We use the 5-gallon oil cans, converted into pails, for feeding the sprouted oats and grain. The weight of a pail full of grain being ascertained it is an easy matter to gauge the quantity that should be put into each pail to

make up the proper amount for each yard of birds. When the mash is checked out at the end of the week and the pen-quantity of grain is ascertained, it is noted on a card tacked to the wall and the pails are filled each day according to that record.

The grain used is varied according to the market prices of different kinds. We try always to feed **some** wheat and **some** yellow corn and we avoid the use of seed barley (with the hulls on it), when we can do so without running the grain cost too high. Wheat and corn are the standard of price with us and we value other grains according to their supposed feeding value as compared with these. For instance, if seed barley is more than 80% of the cost of wheat and the wheat can be had, we buy the wheat; if the sorghums—milo maize, egyptian corn, kaffir corn, etc.—are more than 80% of the price of yellow corn, we buy and use the yellow corn. But we try at all times to have at least 3 grains in the mixture.

At the present time we are mixing 400 pounds of wheat, 100 pounds of yellow corn and 130 pounds of egyptian corn. Until the barley market was allowed to run wild—at the time this is written barley is quoted us in large quantities at \$3.50 per hundred and we are buying a good grade of wheat for \$3.60—until this occurred we used 110 pounds of re-cleaned seed barley in the mixture. We also had milo maize in the mixture—130 pounds of it. It is now quoted at but a few cents below yellow corn, so we abandoned it.

In less troublous days we fed a straight mixture of 2 parts of wheat and 1 part of yellow corn; and if a reasonable price level is ever established again we would return to that standard mixture.

The grain is mixed on the concrete floor in the teed-house and it is put directly from the floor into the pails, the remainder of one mix lying there until the next day when it is used up and a fresh mix is made.

We use nothing but sweet, sound, well matured grain ; under no circumstances do we buy or use damaged stuff. Corn must be watched especially—it must smell and taste sweet. Mouldy feed of any kind is extremely expensive chicken feed. It not only hurts the birds, often causing diarrhoea, but it checks the egg flow. We are about ready to admit that a poultryman could better afford to starve his birds for three or four days than to give them mouldy feed.

The grain is mixed and the pails are filled and set in place, ready for feeding, as soon as the early morning work is over. There is always time to spare at that period of the day. During the dry season the pails are carried to the several gates and are covered over to keep wild birds out of the grain. When feeding time comes there is no delay, and the actual feeding takes but a very short time. The pails are carried into the yards and one is tilted under the arm and the grain is spilled out in a thin stream. The aim is to move as quickly as possible so that all of the birds may have an equal chance, and to make as long a stream as possible. In the larger yards two men usually work together and a double stream is run out. With the system we employ it is surprising how quickly a flock of four or five thousand birds can be fed.

We make it a rule never to deviate from the feeding plan—we start at the same yard each day and the round is always identical. It makes the birds nervous to feed

on a helter-skelter plan, starting here one day, there the next.

We feed by the clock and vary the time with the weather. As the seasons change, making it necessary to feed earlier or later, we advance or drop back a few minutes each day until the proper hour is reached. The flock should not be kept standing at the fence for an hour or two—until you return from a visit, perhaps. You are losing money every minute they stand there, for a standing hen spells a standing loss; your money-maker is moving.

When it is necessary to keep the birds indoors the feeding is much slower as the grain must then be scattered widely because of limited floor space. This cannot be avoided. The change always affects the egg yield, as does a sudden change in the weather; it is simply a case of the choice of two evils.

The actual feeding of the oats, greens and grain, is never interrupted once it has been started. We do not stop to pick up an egg that lies in the yard or a bird that is out of condition—such things are attended to when the feeding is finished. Nor do we allow strangers to crowd the fences, let alone enter the yards when the birds are feeding. Ladies with violent clothes or fancy parasols or even ordinary umbrellas (carried open), frolicsome children, playful dogs—all of these are barred from the vicinity of the houses and yards. Young pullets are especially susceptible. An open red parasol once gave us several hours' work gathering a flock of young pullets from the tops of houses and the neighbors' premises.

We always call the birds when feeding so as to round



up any strays that may be working in the house. So far as the birds are concerned it makes no difference what your call may be, whether a verse from the Bible or a bit of profanity, so that it is the same call all the time. As a matter of fact the writer talks to (or at?) the birds from the time they are hatched. We think they understand the spirit from the tone. Going through the houses at night we can start one lot after another to answering a softly spoken greeting. The habit is worth while when a riot breaks out in the flock at night, as it will at times. The writer can open a compartment door wherein the birds are in full cry and quiet them with a few words; and if it breaks out again we wander around rather carefully after making sure that our shooting irons are really loaded.

The hens in the broody coops are given no mash; sprouted oats, greens and grain are fed them on the regular rounds.

### Cost of Feeding a Hen

The table following shows the month by month cost of feeding a hen on our farm during 1913 and 1918. The comparison is interesting.

	1913	1918
January .....	15 1/3c	18 3/4c
February .....	15 1/4	19 3/4
March .....	13	20 1/2
April .....	13 1/3	21
May .....	13 1/2	22 1/2
June .....	14 2/5	20 1/4
July .....	14	19 1/2
August .....	13 1/3	16 1/2
September .....	10 1/2	16 1/4
October .....	13 1/2	17 1/4
November .....	12 1/2	17 3/4
December .....	14 1/4	20 2/5
Totals .....	\$1.63 1/10	\$2.29 4/10



PARTIAL VIEW OF 1300 WHITE LEGHORN PULLETS FEEDING ON THE TUMBACH EGG FARM

The term "Feed" as used in this connection is a misnomer to this extent—we include the cost of disinfectants and litter used.

Allowance must be made for the fact that we buy in large quantities. But we do not speculate on the grain market—our feed is bought from month to month as needed.

### Sprouting Oats

The oats are soaked in wooden pails overnight and are then spread in wooden boxes having sides and ends 6 inches high. In cold weather the grain is piled up in one end of the box and is heavily blanketed with sacks at night, the boxes resting flat on the ground. It must be kept moist but not soggy-wet. The box should be set out of level so the surplus water will drain off. The grain is stirred up each day. When the sprouts begin to show it is thinned out by spreading it in the box. In warm weather it is piled up about 3 inches high at the start and is gradually spread out. The grain is always covered over with burlap which is kept moist. The boxes are raised from the ground during warm weather and are sheltered from the direct rays of the sun.

Care must be exercised to keep the grain from heating and spoiling. Nothing short of experience will demonstrate how long it may lay and how thickly it may be kept. In normal spring weather we allow it to lay about 3 days from the time it is put into the boxes. If a lot "goes bad," in which event it will either show green mould or become slimy, with a disagreeable sour odor, it is thrown out. Spraying the boxes at intervals with the regular

spraying material is good practice. We always have one box empty and drying out.

The use of sprouted oats is not a necessity. We go to the extra trouble because the birds relish the feed; it is a palatable variety and anything of the kind is a benefit. It has been said by men of scientific trend of mind that sprouted oats are rich in the digestive agent, **vitamen**. This may or may not be so—it is entirely beyond our limited mentality. We feed it for the reason given.

### Water and Care of Water Pots

We use two one-gallon stone water jars in the water shed of each 50-foot compartment. These are fed by self-regulating float valves. A faucet is installed in each water shed for use in cleaning the pots, watering the broody hens, and wetting down the yards. The water pots are scrubbed with a coarse brush every day, usually just before or just after noon. We think it important that this be done. Particles of dry mash adhering to the beaks of the birds are washed into the pots and if this is allowed to stand in the pots it soon becomes sour and forms a slimy mass which would be far from healthful.

The birds **must** have fresh pure water at all times. Neglect your feeding if you must neglect something, but do not neglect the water. During hot weather we make sure that the outer doors of the water shed are in such position that the pots are shaded from the sun.

### Gathering the Eggs

We gather the eggs twice each day—at 1 and 5 p. m. We use 4 gallon galvanized iron pails, which hold 150 eggs nicely. Two pails are carried to a compartment;

one is hung out of reach of the birds while the other is filled; the full one is set outdoors, and when both are filled they are carried to the egg room. We do not load them on a wheelbarrow or cart. The distance is not great and we find the breakage to be much less if they are carried.

If an egg is dropped the remains are picked up as well as may be and are thrown into a mash trough. It is bad practice to allow the birds to eat a broken egg where it lies. Not only may egg eating be thereby encouraged but the hens soon form the habit of following the egg buckets, and if by chance a bucket of eggs is left for a moment they will be found pecking at the eggs. An imperfect shell near the top means an egg broken into the mass; and this in turn means washing the whole lot as the white will glue eggs together wherever it touches them. Nothing but a thorough soaking will disengage them and many will adhere and be broken in spite of it.

At the last gathering the nests are closed. The broodies can be taken out and put into the broody coops during the last gathering. The nests are opened after dark, at which time the outer doors of the house are closed during the late fall, throughout the winter, and in the early spring. The compartment doors are always closed at night and are re-opened when the sprouted oats are fed in the morning.

The trip through the houses after dark is thought advisable. One can keep in touch with the roosting conditions, and should colds develop it will quickly be noticed.

### Grading and Packing the Eggs

We grade the eggs according to the specifications of the Los Angeles Produce Exchange. This calls for three

grades: Eggs weighing not less than 22 ozs. per dozen, averaging not less than 24 ozs. per dozen, and weighing, case included, not less than 55 pounds to the 30 dozen case; these are called "Fresh Extras." The second grade is known as "Pullets"—not because of their being laid by pullets but because of their size. They must weigh not less than 18 ozs. per dozen, running to less than 22 ozs. and averaging 48 pounds to the 30 dozen case, case included. Those running smaller than the "Pullet" size are called "Peewees"; this grade is made up of the first eggs laid by the pullets which are usually undersized.

Each egg must conform to the weight requirement. This is obtained by the use of a special scale made for the purpose; the weights provided with the scale will balance one-twelfth of 22 and 18 ozs. respectively. A little practice enables one to weigh the eggs very rapidly and after a time many can be passed into the proper grade without weighing.

We pack no eggs with weak or broken shells; and eggs that are very much soiled are washed. These are put into a special case during the storage season (March to May) as a washed egg will not stand up in cold storage.

A special grade is made for other than white-shelled eggs but as we have no other this does not interest us.

The eggs are allowed to stand in the buckets over night so that the animal heat may escape before they are packed. We have demonstrated the fact that eggs packed immediately will sweat in the card board fillers of the case and the quality is thereby impaired, especially for storage. Contrary to general belief an egg taken from the nest while yet warm and cooked immediately is not as

good an egg as one that has been allowed to become "set" by a 24-hour cooling.

### Marketing the Eggs

Our entire output of eggs for table use is sold to a wholesale egg merchant on a yearly contract. The eggs are called for and empty cases are returned three times a week. We make no sales whatever outside the contract—not even a single dozen. The merchant who contracts our output knows from one day to another just what he may count on. Such an arrangement enables one to obtain the best possible price.

It is the writer's belief that a middleman or his equivalent in some form or another is an absolute necessity, especially in the egg business, the product of which deteriorates so rapidly. The egg farmer must have a place where he knows his entire product will be accepted and welcomed at a fair price. If he is working on the right system his time will be well taken up, especially during the season of heaviest production. At that time he should be brooding chicks. To interrupt this most important activity or to curtail the number he might handle by giving part of his time to the selling end of the business is a serious mistake.

If the man who markets his products in small lots, selling what he can at retail and dumping the remainder finally at wholesale, would take the trouble to keep record of the time spent along with the difference in price received for the remainder, compared with what he could get if he sold the whole product; he would easily see the point herein made. But his greatest loss is not apparent.

This is represented by the profit he might have made from the additional pullets he could have raised.

A retail merchant counts his time, interest on investment, wear and tear on delivery equipment, and similar charges as part of the cost of the article he handles. The average farmer, on the contrary, counts none of these when estimating the additional profit he made by retailing. But the fact that he does not count them cuts no figure—the cost is there just the same.

The view expressed, summed up, is that the egg farmer should make his entire profit in the production of the egg. If there is no profit, or too small a profit, in the production end of the business he had better retire from it.

Co-operative marketing of the product of egg farms has come to be much in vogue in California. Where the production is limited, and especially where a number of egg farms are located within reasonable distance of each other, the plan has much in its favor. The all-important question is, what does it cost to handle the business? Perhaps equally important is the question of how far should the operation be carried? When co-operative associations enter the field of retailing and cold-storage they are reaching the zone of thin ice from the writer's point of view. Insofar as they may be used in establishing and maintaining a fair price for the product, the cost of which they should have no difficulty in determining, they are clearly within their proper field.

The subject is a large one, however, and what has been said merely touches the surface. Those who are considering that form of marketing their product may well give thought to these general suggestions.



### Selling Hatching Eggs and Baby Chicks

We contract our surplus hatching eggs to a commercial hatchery on the same general plan that is followed in marketing eggs for table use; we make a contract for the whole supply by the year. And as has already been said, we do no hatching whatever. This course was adopted after a number of years' experience doing our own hatching and selling such odd lots of hatching eggs as we could find a market for. We do not obtain as high a price for the eggs in this way but we sell them all. We prefer a certain small premium to a possible larger one.

To those who prefer making the experiment for themselves or to those who have time to spare for such activities we have one bit of advice to offer: Do not make the common mistake of booking in advance orders for eggs or chicks that may, by any possible chance, interfere with your own hatching dates. Set your own dates and stick to them. Should there be any doubt of your having enough eggs from your own flock arrange for the possible deficit elsewhere. Let nothing interfere with getting your chicks and all of them at the time or times you decide to have them.

The writer has seen a number of ventures founder on this rock. The demand for hatching eggs and baby chicks is extremely heavy during the choice hatching months. To grab off the few pennies that might lie in selling the eggs at hatching prices the thoughtless poultryman engages and sells the eggs at that time and hatches for himself when the demand slackens. This is suicide. It is akin to selling all your good apples and keeping the rotten ones for yourself.

### Cleaning and Disinfecting

The dropping boards are cleaned every ten days and the concrete floors are cleaned of litter every three months. In wet weather cleaning the drop-boards every week is advisable.

A long handled, square-point shovel is used, face down, on the drop-boards, the droppings being pushed toward the back wall; this scrapes them clean. A large hoe is then used to pull the mass into a wheelbarrow, specially built to fit under the edge of the drop-board. A wide rake and a scoop shovel are the best tools for cleaning out the litter, along with a spade to loosen any droppings that adhere to the concrete.

When the buildings are new we spray them before birds are put into them. Thereafter the underside of the roosts and crossbars and the drop-boards are sprayed after each cleaning. When this has been done for several months the wood becomes thoroughly saturated and they are then sprayed once each month.

We use stove distillate, a thick brown liquid, and mix with it 5 per cent of creosote. The latter can be bought in drug or paint stores. It is applied with a 5-gallon compressed air sprayer which can be bought at seed stores.

The spraying is usually done in the afternoon, after the first gathering of eggs, to lessen the chance of the birds getting their feet into the stuff and then walking over a lot of eggs. This mixture is likely to cause discolored feathers, especially in wet weather, but years of use of it has demonstrated to us that it will keep out vermin and we chance the discolored feathers.

We do not approve of the water mixtures for spraying; we prefer the oily base which saturates the wood.

A cheap grade of kerosene may be used in place of distillate.

### Disposition of Manure

All of the manure, both drop-board material and litter, is sold under a yearly contract. The purchaser does the hauling.

There is keen competition for it in this section for use in fertilizing citrus groves. It seems generally agreed that it is the most valuable of all fertilizers. It is worth at this time about \$8.00 per two-yard load, at the farm. When we started in the business we gave it away. Our total sales up to this time have brought us more than \$1,200.

A cubic yard of drop-board material averages about 750 pounds in weight during the dry summer months.

### Freshening the Yards

The yards in use are either ploughed or cultivated once each month. If the ground is dry the sprayers are put on and it is thoroughly wet down the day before the ploughing is done.

When old hens are sold off and yards are vacant they are ploughed and sowed to barley. This is used to supplement the supply of green stuff through the late fall and winter. Barley planted in September is high enough to be cut with a scythe in about six weeks and we have had as many as four and five cuttings from it. It is finally allowed to head out and mature when it is cut and used for litter. Maturing the grain seems to purify

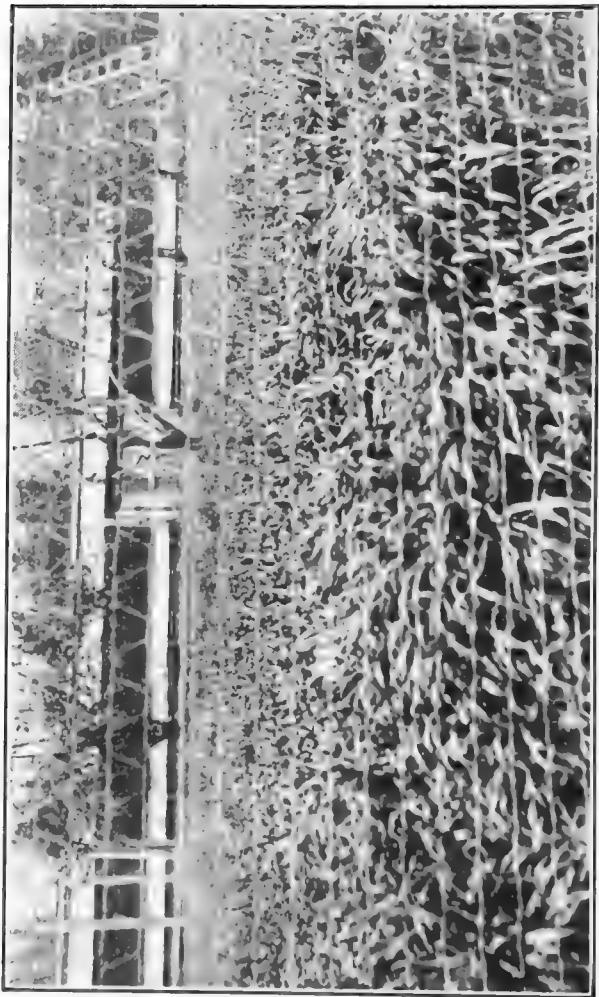

YARD OF LAYING HOUSE FRESHENED FOR YOUNG PULLETS WITH HEAVY CROP OF GREEN BARLEY ON THE TUMBACH EGG FARM

the soil most thoroughly. The edges and corners of the yards are turned over with a spade so that no unclean portions remain.

When several compartments of birds are opened into one, by opening the partition doors, one section of the yard is closed off. This is sowed to barley and the birds are turned into that yard as soon as the barley is 6 or 8 inches high, the other section being sowed. This is continued throughout the year, excepting during July and August when hot weather makes barley-growing impossible.

Young stock is never put into a yard without growing barley in it. This is an invariable rule.

### Breeding Plan

We use nothing but January hatched male birds for breeding purposes, the sons of December layers. Cockerels are mated with yearling hens and yearling cocks with January hatched pullets. We prefer not using eggs from the January hatched pullets for the January hatches of the following year—they are used for the March hatches.

We mate at the rate of 20 to 1, with not less than 500 birds in one yard and house; as a rule we have from 1,000 to 1,500 in one flock. The cockerel-hen mating is made early, usually in August; the pullet-cock mating is deferred until November.

The birds should be mated at least two weeks before the eggs are used.

Our experience has been that the male birds are much better off if they are not taken out and segregated from

the hens once they are mated. We never separate them if the male birds are to be used in the breeding yards again. We double them up when the hatching season is over, keeping in one yard all the males that will be carried over. The males are dusted for lice when the change is made and again when the yards are made up for the following season. The male birds are inclined to neglect the dust bath.

The hens are not selected—we mate the flock as it stands. A hen that has passed through her first laying season, escaping our culling sickle, and that goes through the moult in good shape, again escaping being culled, is considered a fit mother to our next year's pullets. This may not be the correct method, but it is the method employed here; and it is the method employed in gaining warrant for the title of this book.

### **Selling the Old Hens**

We carry the layers through two laying seasons and sell them when they reach the non-profit stage at the end of the second season. Pullets raised in the spring of 1919 will be sold in the fall of 1921. When the egg yield decreases to a questionable point we make a rough calculation of the daily cost of feeding the lot of hens to be sold; and when the value of the eggs laid in any one day does not show a profit over the feed cost the birds are sold in one lot.

It is possible to pick out the birds that are still laying, either by their appearance (if one has the experience necessary to judge), or by taking them off the nests day by day for four or five days; we have done this several times

and made a little profit by it, but as a rule the profit to be made thereby is too small to warrant the time and effort expended. We take no interest in anatomical tests.

We arrange with a market man to take the whole lot. Grading the hens by weight usually results in a better price; this can best be done at the time they are crated. But we try to make a bargain on the basis of splitting the price between the high and middle quotations. The low price, which applies to culls of very light weight, is not used in this kind of bargaining where the "pen run" is sold and none are selected to be saved out. If the best are being saved out to be carried over the price is likely to be shaded. In selling the "pen run" of two-year-old birds in the months of September and October we find they will average about  $3\frac{1}{2}$  pounds. If they are sold earlier, or if they are carried until late in November, they are likely to weigh a fraction more. Older hens will generally average more in weight.

We prefer having the birds crated and made ready for transporting to market at from 3 to 4 o'clock in the morning. At this time the majority of them can be taken off the roosts and put into the crates inside the house. This is a great saving in time and labor. We have handled lots of a thousand in this manner and had the loaded trucks drive away before 7 o'clock.

### Egg Yield per Hen

Our best egg production in 1918 was from a yard of 500 pullets, with an average of 152.4 eggs per pullet. The lowest pullet yield was 145.1 per pullet from a yard that originally contained 900 birds hatched March 30th. The

hens laid an average of 120.4 eggs in 11½ months. The table following shows the spread of the yield from the 145 egg pullets and from the hens:

Month	Egg Yield per Pullet	Egg Yield per Hen
September, 1917 .....	1.1	6.
October .....	5.6	3.7
November .....	10.5	3.2
December .....	13.7	6.
January, 1918 .....	13.1	10.3
February .....	12.8	12.2
March .....	17.2	16.8
April .....	17.3	17.4
May .....	16.7	16.
June .....	13.4	12.
July .....	12.6	10.3
August .....	11.1	6.5*
<hr/> Total .....	<hr/> 145.1	<hr/> 120.4

This table is presented for the benefit of the beginner who may wish to know what he might expect as to egg yield from month to month. Its use as a guide is only relative, however. Weather conditions, both during the growing period and during the laying season, will materially affect the egg-flow. Some seasons there will be a heavier production during October and November with a decline in January, and in such case the yield in the following season is apt to be lighter, especially during the summer and fall.

\*NOTE: The hens were sold on August 15, 1918, on which day they failed to pay their feed bill.



Could we control the egg-flow we would much prefer having a good, but not heavy yield from the pullets during the first fall with a proportionately heavier flow during the second year. We have had years when this occurred and we think it is more nearly the ideal.

### Electric Lights

We do not use electric lights to force the pullets into heavier laying during the fall. We have so far been unable to gain information, based on authentic records, as to the profitableness of such a method, especially if the birds are carried through a second season and are used for breeding.

A true comparative test of the merits of electric lighting involves, from our point of view, a two-year laying record along with a comparison of the number of eggs produced during the profitable hatching months; the comparative hatchability of the eggs and livability of the chicks; and finally, the comparative mortality among the layers during both years.

When, if ever, the profits in the work grow more scant we will make the test; but following our invariable rule on experiments we will divide a lot of pullets hatched at the same time, from the same parent stock, raised under identical conditions, and divided impartially, one lot being lighted, the other not. During the last few years, since electric lighting sprang into favor, we have done too well financially to warrant departing from our proven methods.

### 200-Egg Hens

The month-by-month yield herein outlined will doubtless be disappointing to the beginner, especially so if he

reads poultry items telling of two hundred and three hundred-egg hens. The egg-laying contests conducted throughout the country are apt to be discouraging also, unless the records are carefully analyzed.

In either case the reader must consider not only the number of birds that reached the high goal, but the number competing that did **not** reach it. An authority has stated that in one contest where nearly 3,000 pullets were entered, from 5 to 15 in 100 laid 200 eggs or more. Those entered are of course the very cream of the flock from which they came. If we allow but 1,000 birds for each flock represented, the 3,000 mentioned represented then a total of 300,000; and if we take the maximum of 15 per cent to have reached 200 or more eggs, we have 450 birds of that class out of 300,000.

Viewed from this standpoint 200-egg hens would seem to be almost as scarce as the proverbial hen's-teeth.

A higher production per bird may be attained by keeping fewer in one enclosure as is done in the laying contests. Here the economic feature enters into play again. How much more will it cost for housing and in day-by-day labor to increase the production in this manner?

We are satisfied that we can make more net money in the course of the year by carrying them in large flocks as we do, with a production as herein outlined; not **per hen**, but in sum total. And we would rather have 4,200 birds showing a net profit of \$2.50 each than 1,500 giving a return of \$5.00 each.

### **Trap-nesting and Other Forms of Intensive Selection**

Trap-nesting, carried on persistently and systematically in connection with scientific breeding and careful pedigree work, may unquestionably be made the means of increased production per bird. But from the standpoint of the commercial egg-farmer the economic features must be taken into consideration. It is purely a question of what it will cost in money, time and labor to attain the desired objective and whether or not there will be a greater net profit at the end of the year—not per bird, but in total dollars.

That “total net profit” is the only influencing factor with us, allowance being made for the fact that we wish to continue year after year. Almost anyone would rather have two 150-egg pullets than one that will lay 200—if profit is the objective. We have never experimented with trap-nest work, but the writer believes that he can raise and care for a sufficiently greater number of 140-150-egg pullets by the plan and with the methods he follows to more than offset the profit to be derived from the higher individual production that may be attained by the trap-nesting method.

And so we do not trap-nest.

We do not practice other forms of selection of layers by anatomical tests because we have no faith in the accuracy of any such method that has come to our attention. So far as we know no such method has stood the test of a comparison with trap-nest records; nor do we know of anyone who has succeeded by any such method in gaining a greater net profit in one year than we make with a flock of equal size and with the expenditure of the same time and labor.

### Size of Eggs

To a certain extent the size of the eggs laid will be dependent on the breeding of the hens that laid them. A chick hatched from a large egg will not necessarily prove to be a layer of large eggs; but a **flock** of hens raised from chicks hatched out of uniformly large eggs will be more apt to average large eggs than a flock from chicks hatched out of eggs which have not been selected for size. Nor will a large hen necessarily lay a large egg—the reverse is more likely to be true with Leghorns.

The eggs will vary in size with the age of the layer; and feed, water, weather, and what might be termed tranquility will also affect the size.

Pullets just coming into laying usually lay small eggs and the quicker the maturity the smaller the first eggs will be. Fall hatched birds mature quickly and will lay small eggs for a long time. The same may be said of January hatches; but the eggs will grow larger in less time. March hatched birds will lay but few small eggs at the start if they come in normally—in from  $5\frac{1}{2}$  to  $6\frac{1}{2}$  months; if they are slow and do not come in until 7 or 8 months the first eggs will be larger, often of normal size.

In the second laying season eggs from all of these birds will be larger, many of them too large. But in the third season they are apt to be smaller if the hens have run to fat. This has been our experience, though it may not hold good generally. It seems to be agreed, however, that hens three years old and older lay more eggs having imperfect shells.

Improper feeding will affect the size of the eggs. On

our mash formula, which carries 15 per cent of meat and fish meals, we have found that feeding half and half of grain and mash gives us a more uniformly large egg. If the feed gets out of balance, the error shows up quickly in the larger proportion of small eggs laid. This particular point, confirmed later by experiments, was first called to the writer's attention by his very good friend, Mr. M. A. Schofield.

Failure of the water supply, even for a short time, will result in smaller eggs; so, too, will the giving of salts.

A sudden hot spell following moderate weather is usually accompanied by a run of smaller eggs.

Fright, or moving hens from one place to another, will be followed by a run of smaller eggs. But back of it all is the question of whether or not the birds come from a strain that has been bred to lay large eggs.

### Nest Materials

When the nest boxes have been thoroughly sprayed we allow time enough for the spraying material to saturate the wood and the surplus to dry off. We first put in a double handful of tobacco stems; these are purchased from cigar factories. The box is then filled to within an inch of the top of the front board with fresh pine shavings. Redwood shavings should not be used. An egg broken in a nest of Redwood shavings, or any other form of moisture coming in contact with them in such a nest will badly discolor the shells of any eggs laid in that nest, and this discoloration is apt to prove practically indelible.

### Designation of Chickens

We are often asked the meaning of "Hen, Pullet, Cock-erel and Cocks." We do not know the established rule of usage. In the hands of a dealer who is selling live birds, every female is a pullet—if he can get away with it, especially in the fall when only pullets are supposed to be laying. Early moulters answer the purpose most admirably.

With us they are "Pullets" until they have passed through their first complete moult; birds hatched in January go through a light moult in their first fall, but they are still pullets with us until the following fall. So, too, is a fall hatched bird.

After the first full moult they are "Hens"; and if we carried them long enough they would be "Yearling Hens" and "Two-year-olds."

The same rule applies to the males. They are "Cock-erels" until after the first full moult, when they become "Cocks."

In table poultry we seldom get beyond the "Broiler" stage. Under  $1\frac{1}{2}$  pounds they are usually known as "Squab Broilers;" from  $1\frac{1}{2}$  up to  $2\frac{1}{4}$  pounds they are "Broilers" and beyond that they become "Fryers" or "Soft Roasters." In the Leghorns especially if a young bird gets into the Fryer class the marketman is particular to see that it is still "soft-boned"—that the point of the breast bone is still soft and pliable. If it is not they are classed as "Stags"—so far as paying the producer is concerned; what class they take when sold to the consumer is another matter.

# DISEASES

---

## Foreword

Many poultrymen deny having sickness in their flocks and we have even known of some operating on a large scale who profess to lose few if any birds. This makes it hard on the beginner and to the writer it seems unfair because of the discouragement felt by the beginner who encounters trouble and loses birds. The writer knows—he has been there. And it is his purpose herein to prepare the inexperienced for possible trouble. He will also give his experience as to mortality. The reader who is susceptible to suggestion is reminded of the fact that the writer earned the title of this book in spite of his experience with disease and mortality; without that sad experience he would long since have retired to a life of ease. It might be proper to add that we have met but few retired egg-farmers.

What has been said in connection with diseases of young chicks might well be repeated here, however. Do not take too seriously the stuff put out by “the medicine man;” bear in mind that to sell his goods he must show you, perhaps in your own flock, an apparent reason for using them, and remember that he has not come to you as a matter of philanthropy. He has come to you literally looking for trouble and as is always the case he who seeks that finds it, especially so if he makes money by it.

From the writer’s point of view the research work that has been done toward eliminating or controlling disease among chickens is both woefully and pitifully of minor extent. The individual object, “just a chicken,” does not

seem to warrant the attention being given the subject that is given where the individual has more money value. A cow or horse looks like seventy-five or one hundred, even one or more thousands of dollars, while a chicken was rated, before these strenuous times, at perhaps twenty-five or fifty cents. It is only when we consider the hen from the standpoint of possible and probable earning capacity and then multiply the figure by one or more thousands, even hundreds of thousands (for the mortality in chickendom throughout the country runs to that annually), only then do we realize the importance of that twenty-five cent subject.

The writer proposes then to record his observations and experience and to exploit his ignorant theories with the hope that perhaps by the very ignorance proclaimed, a discussion may be quickened which will lead toward advancement. He is ready at any time to join in a movement looking to a proper interest being taken in the subject, and his portion of the money needed to finance the enterprise is likewise ready.

### Indications of Health and Disease

There is no simpler and better method by which to judge the condition and health of the birds than by watching the combs and the droppings.

The comb of a healthy bird, excepting during the moulting season, will be a bright red. During the moult the brightness will disappear, the color fades to pink, and the comb will contract in size and may look as though lightly powdered over; but it will not turn color.

A bird out of condition will show a blue or even a blue-



black color in the comb. In extreme weather birds will show a bluish tinge in the comb and this will disappear if the bird is put in a dry, warm place; but the fact that it is susceptible to the weather indicates that the bird is not in what might be termed "the pink of condition."

The careful poultryman will watch the drop-boards as regularly as he watches the nests. The droppings of a hen in good health and condition are voided in a rather compact mass, tending toward a point on one end, greyish in color with a decided cream-colored spot in the mass, and of the consistency of soft putty. Any variation indicates error somewhere. If the mass is too hard there is a tendency toward constipation; if too soft, the reverse. In most cases the variation is due to an error in feeding. This may be the fault of the bird or of the feeder.

Slight variations need cause no concern; the bird may have over-eaten of one thing or another. It is only when violent variations are observed, variations that are apparent for days at a time, that the cause of the trouble must be looked for. If the drop-boards and the yards show masses of watery discharge, or soft yellow or brownish material, it is well to exercise caution.

All flocks will show the effects of a sudden change in temperature, the lack, even for a short time, of pure fresh water, a sudden variation in diet, or the continued lack of some important element in the feed, such as shell, grit or green stuff. The feeding of immature grains, heated corn, or an absence of variety in the ration will also be apparent in the droppings. So it follows that if the off-color or imperfect consistency continues and no other sign of trouble is apparent we must look to the feed and

the water. Only too often the trouble may be found in the water-container—it was probably emptied and scrubbed out two or three weeks ago and is now half full of a slimy mass of corruption. We have seen such.

The droppings always seem looser in wet weather than in the warm summer months, due to failure of evaporation. This must not be confused with a laxative condition.

### **Diseases We Have\* Encountered**

The list of poultry diseases is almost as long as the moral law. In our experience we have encountered and identified:

Colds and Catarrh; Bronchitis; Chicken Pox and Canker; Congestion or other forms of Liver Complaint; Dropsy and Tumors; Limberneck; Clogged Crop; Leg Weakness; Bumblefoot; Eggbound; and Prolapsus of the Oviduct.

The commonest form of trouble in our section is colds and catarrh which are especially prevalent in the fall when very warm days are likely to be followed by cold nights. Frequently the change in temperature at sundown is extreme. This is especially hard on hens in the moult and on young pullets just coming into laying. Again, we have little or no rainfall from May until September ordinarily, and especially toward the end of this long dry season the atmosphere is heavily charged with fine dust.

Chicken pox and canker should probably be accorded second place in this black list. We have had two sieges of it during the eight years we have been in the work, but in some sections it must be contended with much more frequently. The disease is more flourishing in damp

climates. In some sections near the coast there is always more or less of the trouble. It has been observed that an attack is more virulent in cold, wet weather than in hot, dry atmosphere. Freezing weather appears to be no deterrent.

The other troubles encountered are of more or less a minor character compared with the first named. They are the exception rather than the rule and the mortality due to them is insignificant.

**COLDS AND CATARRH:** These troubles are easily recognized. Frequently the birds throw them off with no treatment, especially if a day of unusual weather is followed by a normal one or if there has been some neglect which is remedied.

If you make a practice of going through the houses at night, as we do, you will get notice promptly of cold and catarrhal trouble. Birds will be heard to sneeze and cough, others will have difficulty in breathing, the breath coming in a sort of wheeze. At times one may be heard with a barking-cough; this is more in the nature of bronchitis probably.

If the presence of the trouble is not recognized in this manner it may not be noticed until a more advanced stage is reached, when there will be a running at the nostrils, with inflammation at the eyes and possibly a cheesy deposit in the sockets of the eyes. This may lead eventually to a severe swelling around the eyes. At this stage the eye may become entirely closed over with the cheesy deposit extending through the nasal passage into the mouth and throat. A bird in this condition will starve to

death. If it is a vigorous specimen to begin with it can overcome the trouble if it is fed.

Some authorities class this trouble at one or more of the stages described as roup or roup<sup>y</sup> catarrh. If roup is as contagious, as deathly and as quick in action as it is credited with being, the presence of these symptoms does not necessarily signify the presence of roup.

**CHICKEN POX AND CANKER:** Careful observation has proven to us that a siege of pox and canker is invariably preceded by signs in the droppings. During our last run of the trouble we identified these signs and were able to forecast within a few days of the time when it would break out in a given section of the plant. The particular sign is the voiding of an irregular mass, usually about one-half normal size, of a peculiar grass-green color and which, if it came into contact with an eggshell, was practically indelible. The fact that it was found on eggs in the nests indicates that the affected bird was probably laying, from which we deduce that the disease is of quick development.

It is the writer's belief that it develops in the intestinal tract. This is contrary to the idea that the disease is a fungus growth, contagious through infection of wounds or scratches.

Whether or not chicken pox and canker are always coincident is immaterial. We have never had one without the other, excepting in what the scientist terms "sporadic" cases which as we understand it has reference to a single, isolated case of a disease which is ordinarily epidemic. The writer recalls an instance several years ago where he found a perfectly developed case of chicken

pox in a yard of 1,200 hens, and no other case developed in the flock.

The origin of the trouble is shrouded in mystery so far as the writer is concerned—as much so as is “Spanish Influenza.” Fluent writers, poultry “experts,” and men of science easily and airily ascribe it to filthy, unsanitary conditions; to infection, either from a strange bird brought in or from birds of the air; or to other equally indefinite causes.

As to its originating or germinating only in unsanitary, filthy quarters—this is rather hard on those of us of the poultry fraternity who live and have our being in the welfare of our birds, and to him who has made any serious study of the trouble it simply brands the author of the statement as an ignoramus. It would be rather remarkable that plants conducted on so great a variety of plans and systems as may be found in the poultry industry, that all of these should be permitted to degenerate into filth and disease almost coincidentally. During our last siege we had calls for assistance in combating the trouble from points as much as thirty miles apart; from breeders with thousands of hens as well as from fanciers with a dozen birds kept in gilt cages on carpeted floors.

As to the infection and contagion theories, we are equally in ignorance. Our experience is that not all of the birds in a flock will be attacked. Our records indicate that about 70 per cent of the birds will be immune. And experiments have proven that some birds cannot be infected. We have had healthy birds in the isolation ward where both pox and canker in every possible stage were rampant and the healthy birds could not be infected.

We have also found ground for the belief that a two-year-old hen is more or less immune from infection by one a year younger. This cannot be given as an established fact because the particular two-year-old may have been one of the immunes. But in the development of the disease we had the same experience in both our sieges, the disease ran through different yards of hens of the same age at the same time, leaving the younger or older free of it; and when it attacked the birds of the other age, it ran through all of the birds hatched in that year regardless of where they were kept.

It has been noted that 30 per cent of the birds were affected. Of this 30 per cent, 25 per cent either died or had to be put out of the way because of canker in both eyes. This indicates a mortality of  $7\frac{1}{2}$  per cent. The figure may not be taken as entirely accurate for the reason that it includes ordinary mortality which was not necessarily due to the pox and canker. It was found impracticable to distinguish.

A flock attacked by this disease will show a decrease of from 50 to 60 per cent in egg production; a flock that has been laying 1,000 eggs will drop to four or five hundred, and the production will reach the minimum in a very short time.

The disease runs its course, in a large flock, in from 60 to 70 days. In that time the egg production will again resume normal proportions, allowing for the mortality and for the time of year. It is our experience that the loss in production will be made good by heavier laying later in the same season or by abnormally high production in the season following. The pullets attacked

during our first siege laid more eggs per bird in their second season than in the first, and during their second season they were within a few eggs of equalling the record of the next year's pullets.

It should be kept in mind that what has been said herein has reference especially to pox and canker running at the same time. We have never had one without the other. From our observations we are not fearful of pox as a separate disease. The writer believes it would run its course in a short time without dosing and if the birds are vigorous at the start and have been well cared for that the mortality would be negligible. That it exerts a harmful influence stands admitted, but in conjunction with canker, if the canker is a separate disease, it is far from harmless. The only deaths occurring during a run of the trouble, the cause of which we have been able to identify beyond question, have been due to the canker.

**Symptoms:** Chicken Pox may be recognized by a wart-like, pimply eruption on the comb, wattles, face, and on the edges of the eyelids. In its earlier stages the eruption is light colored and transparent, darkening as it develops, and finally peeling off in a scale. We have had cases where one or both eyelids were affected to the extent even of one eye being entirely closed and the other almost entirely. If even the tiniest portion of one lid remains uncovered so that the bird can find feed and water, recovery may be made if the bird was in good health and flesh at the start.

Canker in some respects might be likened unto a cancerous growth, in consistency much like gristle. It may form in the throat, usually on the rim of the opening

into the windpipe, or in the ball of one or both eyes. It develops very rapidly. When the seat of the growth is in the windpipe life or death is dependent entirely on whether the enlargement is downward or upward. If downward the bird will choke to death, oftener than not before the trouble is apparent. Birds will be found dead under the roosts or in the yards or nests—fine, plump hens. Examination if carefully made invariably discloses canker in the windpipe below the opening.

If the development is outward the bird may be saved if caught in time. Presence of the trouble is indicated by a slight wheeze in breathing, the mouth being held open slightly all the time. The bird will live as long as there is even a pinhole through which to breath. Large plump birds will be observed at times, apparently in the pink of condition, whose bright red combs turn to a dark blue before your very eyes. This is strangulation. Quick work will save many such cases.

### Other Diseases

A **cropbound** hen usually advertises her complaint. The crop bulges out or hangs downward. We have had them with crops as hard as a stone. It is due to something clogging the opening from the crop.

**Limberneck** is usually due to ptomaine poisoning, the result of eating decaying matter. The bird loses control of the muscles of the neck and will lie with its head on the ground, the neck stretched out. Again, the neck may become rigid.

**Dropsy and tumors** in the egg bag very often run together. Older hens are more likely to be affected than



young ones. The rear portions of the bird will swell to great size and the bird is literally heavy as lead.

**Congestion of the liver** and other liver troubles are usually evidenced by discolored combs. The comb turns blue, even blue-black, and remains so. This must not be confused with a somewhat similar discoloration due to a chill or continued exposure to bad weather; in the latter case the comb will resume normal color if the bird is put in a warm dry place.

**Prolapsus** is a projection of the egg-laying organs; the entire egg bag will sometimes be forced out. This is commoner with young pullets just beginning to lay, although older hens will be afflicted under certain conditions.

**Bumblefoot**, so far as the name is concerned, must have been invented by a practical joker. It is simply a sore foot. The bird sustains an injury or runs a sliver into the ball of the foot resulting in a puss formation.

**Egg-Bound** is the inability of the hen to pass the egg, usually a fully developed egg. The size of the egg is not necessarily the cause—it is more likely a paralysis, perhaps temporary, of the expulsion muscles. Hens in this condition may remain on the nests all day and be found there at night, showing signs of distress, or more likely they will be off and on the nests and may be observed straining to pass the egg.

**Leg Weakness** is common among pullets just maturing and coming into laying and cases are found at times amongst the older hens. We class the former as being due to some defect in the laying organs; the latter is more often rheumatism, although cases are recalled

which conform to the description of tuberculosis given by that eminent authority, Professor Dryden (Oregon).

A pullet attacked with leg weakness goes down completely and her legs are useless. There is no evidence of pain when the bird is picked up and the legs are manipulated.

The cases amongst hens which we class as rheumatism are distinguished from the pullet cases by the fact that the bird shows signs of pain if the legs are touched. The bird does not lose flesh and the appetite is normal. The cases which may be tuberculosis differ in that the bird is usually thin and emaciated when the legs fail and the appetite is abnormal—the bird will eat almost constantly if food is within reach. Happily these cases are extremely rare.

We have never identified diphtheria and we have never heard it claimed that either true roup or cholera was ever identified in Southern California.

It may be noted that we do not specifically mention diarrhoea. This is because of a belief that most cases of looseness of the bowels are due either to a cold settling in the intestines or to defective feed stuffs.

### Medicines

In our earlier experience we bought and used perhaps 99 per cent of the various and sundry "remedies" offered for poultry diseases. As we grew older (perhaps not wiser) we came to be like the man who had one standard remedy: if too cold he took whiskey and if too hot he took whiskey.

We buy no "dope" of any kind. Our standard remedies

are: Common Epsom Salts ; Common Baking Soda, and Douglas Mixture.

Douglas Mixture is said to be as old as the hills ; here is the formula :

8 Ozs. Copperas

$\frac{1}{2}$  Oz. Sulphuric Acid.

Dissolve the Copperas in one gallon of water, using a stone or glass jar. When the Copperas is entirely dissolved, which, with frequent stirring, it should be in about 24 hours, add the Sulphuric Acid. Allow it to "set" until the mixture is perfectly clear. It is then ready to use. It is poisonous. Its use will be stated. It costs seven cents per gallon.



THE BIPDS ENJOY NATURAL SHADE IN HOT WEATHER ON THE TUMBACH EGG FARM

## TREATMENT OF DISEASE

The treatment of disease in large flocks of birds is quite a different matter than the treatment that may be accorded one or a few dozen. You will appreciate this to its fullest extent if you try to handle several thousand birds with colds or chicken pox and canker on the basis given in poultry-remedy literature or in the bulletins issued by the Federal Government or the State Experiment Stations. Try it.

The individual treatment that may be given as will be herein outlined is the result of years of work with sick birds by the writer's wife who came to be quite an authority and whose work was eminently successful. She saved hundreds of birds by putting in time which could not be spared from the general handling of the flock and the management of the plant. A beginner, or a poultryman at any stage of the work, who has an orphan-and-stray-cat-loving wife, can save many birds in the same way.

### Treatment in Flocks

Primarily, we prefer "dosing" the birds through the water rather than through the feed. A bird is much more likely to go without food than without water. The water on our place is piped all over the plant. A main line extends through each of the two long rows of houses. At the point where this main line enters the first yard a 52-gallon barrel is installed on a platform six feet high. The barrel is connected to the water line with a shutoff valve just below the barrel. Another shutoff valve is

put in the main line just outside the barrel connection. The barrel is equipped with a drain pipe on which a screw cap is set, to permit of the barrel being drained if desired and to remove sediment. The barrel is filled by opening both shutoff valves. When filled the main line is cut off. When "dope" is to be given it is put in the barrel. This saves a lot of time and work. If some such arrangement is not had it is necessary to watch and refill the water pots promptly.

**COLDS, CATARRH AND LOOSENESS OF THE BOWELS.** If signs of colds show up the birds are promptly given a dose of Salts. We give them at the rate of one pound to 250 birds. The Salts are first thoroughly dissolved in warm water, which is then poured into the barrel, and the main feed line is cut off. We usually put half the dose in the barrel at night and the balance when the first barrel is consumed. If this quantity is not consumed by 3 or 4 o'clock in the afternoon the first dose is made stronger. The birds are given fresh water at 3 or 4. Fresh water is given the next day; and on the day following the dose is repeated. We have found this the most satisfactory system.

The day after the second dose of Salts, Douglas Tonic is put in the barrel at the rate of one teaspoonful to each quart of water. A measure is made to gauge the quantity needed to each barrellful. The tonic is continued for two or three days, dependent on the severity of the outbreak. If the trouble continues, both Salts and Tonic are repeated the following week and until the attack is checked.

A very good variation in long continued run of colds is to give soda, at the rate of one pound to 250 birds, each

day following the day of Salts, this in turn followed by the tonic.

Should any of the birds show swelled faces or sore eyes they are removed to the hospital yard.

**CHICKEN POX AND CANKER.** We have found nothing that will cure these diseases in combination, and we have found nothing that will protect birds from it. It is our experience that it will run through the whole flock, once it starts, regardless of the measures taken to check or prevent it. Our course has been different perhaps from the ordinary in that we never make an experiment on the whole flock—nothing can be learned in that way. Previous to our last siege, when pox and canker were rife in the country, we used a much-advertised remedy on two divisions of our flock, as a tonic and preventive. These divisions when attacked showed within reasonable degrees the same percentage affected and the same mortality as did those divisions not given the preventive. And one of these divisions was given the further special treatment of a dampened mash in the evening, the “dope” being used in the mash as well as in the drinking water.

We have not tried vaccination. Poultrymen of experience and judgment who tried it a year or two ago reported most unsatisfactory results, and while we have been unable to gain definite figures for comparison yet the inference was that as many birds were lost, either as an immediate result of the treatment or afterwards, as we lost without it. We may try it some time; but if we do it will be on half the pullets from each hatch.

At first signs of the trouble we give the whole flock, not only the division in which it appears, but the whole

flock, a dose of Salts—1 pound to 250 birds, and the dose is repeated three times, on alternate days. Fresh water is given each day at from 3 to 4 o'clock. Douglas Mixture is then given steadily for one week.

Meantime a certain part of the day is given over to picking up affected birds. These are put into the hospital. They are given no special treatment there excepting that Douglas Mixture is kept in the water constantly.

Where canker in the windpipe occurs, if it is discovered in time, the canker is removed with a bone crochet hook. The bird may best be held by crowding the feet between your knees. The head of the bird is held in the left hand, the mouth being opened with the thumb and forefinger. Quick work is necessary to success. The hook is slid into the mouth and is run into the windpipe when the bird draws its breath; the opening is always expanded for a brief instant. In many cases the canker can be peeled out with one deft stroke. If it breaks it is advisable to paint it over with a weak solution of some disinfectant; we use a 10 per cent Argerole, diluted heavily with water. It is applied by means of the tip of a feather which can be run through the opening into the windpipe. Strip the quill until but a brush remains. In 24 hours another effort can be made to bring out the whole mass. Two or three applications will usually soften the growth to such an extent that it will come out readily. If it continues to stick tight the case is hopeless. We have cleaned throats of the tight canker by patient work and brought the bird back to laying, but the canker invariably returns after a time and the bird must be put away.



Where the canker fastens in an eye the eye is lost. In this respect canker must be distinguished from simple pox. Pox-scales will form on the eyelids and close the eyes temporarily but if the bird is watched and is hand-fed and watered regularly, the sight will not be lost; it is, in fact, not affected at all. It is simply a question of keeping the bird from starving to death. The application of carbolated vaseline to such cases will hasten recovery; but they will recover without it, as may be learned by observing a bird who has but one eye closed with the pox-scale. We do not give individual treatment in such cases. Where canker attacks both eyes the bird should be put away immediately—the case is hopeless. We have experimented with removing the canker when one eye is attacked but found it conducive to no particular good. It is painful to the bird and a trial to the operator. The growth will eventually slough off, carrying the eye-ball with it.

Where an eye is lost in this manner the bird need not necessarily be disposed of. If it is in good flesh and condition when attacked there is better than an even chance that it will be profitable to carry it until the next moult.

### Individual Treatment

When time is available for individual treatment a bird with a cold can be cured quickly. A teaspoonful of castor oil; a careful cleansing of the nostrils (of the eyes also if affected) with a soft cloth; the injection into each nostril and the cleft of the mouth of a minute quantity of kerosene, by means of a little "squirt" oil can, milk-moistened mash for a few days, or bread and milk—these meas-

ures will result in a quick and complete recovery. When a number of birds are confined in the hospital and colds are prevalent we keep Douglas Mixture in the water constantly. If this is not available a light film of kerosene on the drinking pot will be found of much benefit.

**Crop-Bound.** We have had little success in treating such cases. The giving of large quantities of olive oil, a tablespoonful twice a day, along with a kneading of the crop, has a tendency to soften the mass, but this rarely removes the obstruction. It is worth trying, however. In exceptional cases the crop may be opened by making an incision with a sharp knife (a safety razor blade is a good instrument). The mass is then removed, the crop is washed out with a disinfectant and the wound is sewed up with silk thread and a fine needle. The bird should then be given soft food for a time.

**Limberneck.** A tablespoonful of castor oil is the best attempt at curing this trouble. We have never had a bird that was worth keeping after such an attack.

**Dropsy and Tumors.** There is no cure for these troubles. It is a waste of time and effort.

**Liver Troubles.** These are due usually to improper feeding and a lack of exercise. The fault may be in the individual bird. If a bird does not thrive on the treatment accorded our flock as a whole we have no time to spend on it. If a number of blue combs show up, we administer the Salts treatment.

**Prolapsus.** If the bird is caught in time she may be saved; otherwise, nine times in ten, the other birds will kill her by drawing out the entire intestinal tract. The parts should be carefully washed in warm water to

which a good disinfectant has been added, and should then be pushed back into place. The bird must then be kept entirely alone. If another egg does not follow within a few days the bird may be able to retain the parts in place. Otherwise she had better be used for the table. She is in perfect health and there is no more objection to her use for food than would be a case of a broken leg.

If pepper or other forcing stuffs have been in use; or if some prepared "laying dope" has been fed previous to a case or a number of cases of prolapsus, the use of such things should be discontinued immediately. If your hens will yield you no profit without them either you or the strain of your hens is at fault.

We have cases here every season when the pullets first come into laying and we have found no means of checking the trouble. It seems a penalty attached to quick development. We have had it even when the birds were kept on a ration without meat product of any kind.

**Bumblefoot.** The bird should be caught immediately and be put where the wound can be kept out of the dirt. The wound should be opened when pus develops and should be carefully washed out. A bandage may be applied—it is another matter to keep it in place.

**Egg-Bound.** The hen should be held over a bucket of very warm water, not hot, but uncomfortably warm, with the hind parts resting in the water; this will have a tendency to relax the parts. Frequently the egg will be passed when this has been done; if not, grease the middle finger with vaseline and inserting it into the egg-duct, grease the walls of the duct and if possible turn the egg. Repeat the warm water treatment if necessary. As a

final resort the egg may be broken, but this is desperate treatment. If the particles of shell are not removed carefully, or if a piece of shell is thrust through the wall of the egg-duct, infection is likely and the hen will be lost.

**Leg Weakness.** We have made all manner of experiments with pullets that go down on their haunches at the time of maturity and have never been able to effect a cure.

Hens with what we classify as rheumatism may be brought back to a certain degree, but the cure is seldom permanent. It is a saving of time to get rid of them.

And the thin, wasted cases have never been experimented with—they are put away immediately.

### **An Occasional Dose of Salts**

During the hot summer months we make a practice of giving the entire flock a dose of Salts about once each month. The dose is at the rate of one pound to 250 birds. It is given just once and is followed next day by soda at the same rate.

### **Conclusion as to Diseases**

Occasion is taken to reassure the beginner on the subject of disease among the birds. Colds and the minor troubles discussed you are likely to have almost any time and regardless of the care given the birds; and so far as pox and canker are concerned, we have had but two sieges of it in eight years. It is not amiss to suggest that if no troubles were to be contended with there would be little if any profit in the work. The writer has been through all forms of discouragement but he has made a good thing out of it, and there is no reason why you should not do as well.

### Parasites

In this respect the poultryman may have four things to contend with: Mites, Lice, Scaly Leg and Worms.

Mites are the chicken house bedbug and they are as much a disgrace to the poultryman as the bedbug is to the housewife. The mites live and breed in the house. They attack their host on the roost at night and suck the blood. If you are as careful and regular in spraying as you should be you will have none of them. A common form of entry for them is to put a new roost or a piece of new lumber in the house without first spraying it. Should they gain entry on you in this manner your safest course is to spray their place of abode **every day** until you get rid of them.

The family tree of the louse family is a widespreading oak. None should concern you excepting the body louse which lives on the bird. As our chicks are all incubator hatched we have none to contend with at the start. Our observation is that lice are present on mature fowls in almost every large flock. The pullets usually stay free of them until they are nine or ten months old. We do not concern ourselves with them. We see to it that the birds have loose moist soil to dust and wallow in all the time and that is as far as we go. We have never found lice in sufficient numbers to be dangerous excepting on birds out of condition that are not removed promptly, and on male birds. The males are likely to be negligent in dusting. When a sick bird is removed if it is lousy it is dusted with "Devil's Dust" to give it a chance to regain its normal habits; and the male birds are given a hand-dusting twice a year. Some birds will keep themselves

entirely free of body lice; but you are likely to find lice on many of them.

Scaly leg, which may look like crusted warts, is said to be due to a mite which burrows under the skin of the legs. A good way to get rid of them is to wash the legs in warm, soapy water, then applying either a mixture of equal parts of kerosene and lard, or perhaps carbolated vaseline. Several treatments may be necessary. If a flock is infested a shallow pan may be set in the doorway where the birds must pass over it; fill the pan half full of water and add a film of kerosene. This is said to be a good remedy. We have never tried it. The only case of scaly leg we ever had was on an old moth-eaten hen with spurs about two inches long, wished on us by a kind-hearted neighbor who was moving away and who could not think of disposing of "Old Pet." She was cured in the manner first described.

Worms have never given us any trouble. We find signs of worms in the droppings at times. Should they show up to any extent we have recourse to our salts and tonic treatment. This is as far as we go.

### Mortality

There is only one true method of arriving at the percentage of hens lost. You must count the pullets hatched and placed in the laying house and when you sell them off later, count the number you sell. This sounds so simple that it borders on the ridiculous but it is surprising how few poultrymen do it—if what they say on the subject of death losses is to be taken as a criterion.

Our experience is that hens will die off constantly, re-

ardless of the care given them, when they are being kept at high efficiency of egg production. It is also our experience that the percentage lost increases with the age of the hens—there will be greater losses among two-year-olds than among the yearlings; and greater among the yearlings than among the pullets. In small flocks the percentage does not seem to be so great but this is because it does not involve the greater number. If two hens are lost out of twenty in the course of two laying seasons the loss does not seem as great as when five hundred are lost out of five thousand.

Our experience indicates that from 10 to 15 per cent is likely to be the mortality each year where the hens are kept through two laying seasons. The experience includes going through two sieges of chicken pox and canker in eight years—the mortality from this cause is included. And as already suggested, the mortality is likely to be heavier in the second year than in the first.

### Culling

We cull constantly, but more especially during the moulting season. The work is based entirely on the idea of eliminating birds that are not in the pink of condition. Rainy weather, foggy mornings, hot evenings—these are good culling times. If a run of colds or other trouble develops—and we all have them—a certain hour of the day, morning or evening, is given over to culling. A bird out of condition will remain on the roost late and will go back to it early; a trip through the house late in the morning and early in the evening enables one to pick up out-of-condition birds quickly and easily. Moulting time



JANUARY HATCHED COCKERELS AND YEARLING HENS IN A DOUBLE YARD OF 1000 BIRDS ON THE TUMBACH EGG FARM.



is an especially good time to cull. Few weaklings will survive the moult; those that do survive it are easily spotted.

• Culled birds are not necessarily disposed of. They are placed in the hospital or in one of the observation yards and houses and are given a chance by having fewer companions to get on their feet again. By far the larger part of our culls are carried over then until the moulting season. They are not put back into the main flock, where they might be used for breeders, but in a special division assigned to returned culls. We have found this a profitable course to pursue. The birds that do not speedily come back to good condition are either put away or are sold to market when they are again in a healthy condition.

We do not go through the flock, handling each bird, with the idea of culling out non-producers or selecting special birds for breeding purposes.

### **Keeping Accounts and Records**

The writer attributes a large part of his success in the work to the keeping of most accurate accounts and records and his advice, to the beginner especially, is to take the trouble of doing so. It matters little or nothing what sort of books are used—a common pencil-writing tablet will do as well as an elaborate set of books.

You should record somewhere the number of chicks hatched in each lot and the date of the hatch. When the chicks are taken from the brooder house enter on this record the number removed. Here is an illustration :

### March 15, 1919—1,200 Chicks

Cockerels to Cockerel House		Pullets to Laying House	
From Brooder House.....	490	From Brooder House.....	580
May 21—from pullets.....	22	May 21—to cockerels.....	22
	—		—
	512		558
May 31—sold .....	78	May dead .....	16
	—		—
June 1—balance.....	434	June 1—balance.....	542

This should be continued until the cockerels are all disposed of and the pullets are laying. The latter are then carried into an account entitled "Record of Laying Hens."

The four examples on page 176 constitute the whole of the system necessary from this time forward. Rule off a page in the tablet for each of the four. It may appear at first glance like a complicated matter, especially to one not accustomed to keeping accounts, but if the reader will take the trouble to apply it to his own case and facts he should have little difficulty in mastering the plan.

It is well worth while. It is the writer's belief that if the plan covered by these four sheets was put into use on every commercial egg farm in the country, a far greater percentage would be successful. The poultryman who keeps these records faithfully knows at all times just what he is doing and what each and every yard of his birds are doing. And therein lies a big factor of success. If your "Earnings per Hen" record showed month after month, one year after another, that yards of birds hatched after a certain time were always far behind yards hatched at another time, you would sit up nights if necessary to get

your birds out in the more profitable month. That is what we did.

As a result of such records we can readily make comparison of earnings of birds hatched in different months during the last eight years. We know how the cost of feeding has varied from month to month in all that time; how many pullets we raised, how many of them were later sold, and how many died off.

It is not only financially profitable to have such records but it enables one to place a true value on the data, statistics, and information of a general nature that is passed along by word of mouth and in the poultry press and in books on poultry.

Our accounts and records go into the subject much more deeply. A general set of books is kept, of course, and in addition we have records that tell us that an average of 4,214 hens consumed in one year 302,398 pounds of grain and mash, an average of 70.57 pounds per hen; that the grain and mash consumption was at the rate of 6.57 pounds per dozen of eggs produced, varying from 4.4 pounds in April to 12.22 pounds in November; the poundage of feed stuffs used in maturing pullets; the cost of raising pullets; the cost of producing a dozen eggs, one year for another. We have all this data. It takes time and a lot of work to go into it as extensively as this, but the writer enjoys it; he enjoys doing it and he enjoys the accurate knowledge thereby acquired. But it is not necessary to go into it as deeply as this.

## SHEET No. 1

## RECORD OF LAYING HENS

1919 Stock

January Pullets hatched.....	1350	March Pullets hatched.....	1870
May, Cockerels out.....	18	July Dead.....	7
June 1, 1919, Balance.....	1332	August 1, 1919, Balance.....	1863
June, Cockerels out.....	12	October, Dead.....	4
Dead.....	7	19	
July 1, 1919, Balance.....	1313	November 1, 1919, Balance.....	1859
July, Dead.....	12		
August 1, 1919, Balance.....	1301		
October, Dead.....	3		
November 1, 1919, Balance.....	1298		

When the birds are sold, mark the number and by preserving the sheet you can always tell what mortality occurred in that particular lot.

## SHEET No. 2

## NOVEMBER 1919 EGG RECORD

Date	January 1919	March 1919	Total Eggs	Wholesale Price	Sales (dozens)	Amount Received (or Value)
1	317	706	1023	60c	690	\$ 414.00
2	328	817	1145	...	...	.....
3	302	786	1088	...	...	.....
4	397	792	1186	...	...	.....
etc.	etc.	etc.	etc.	etc.	etc.	etc.
<b>Total *</b>	12,980	18,590	31,570	...	2,610	\$ 1,566 00

Eggs consumed or eggs used for your own hatching should be entered in "Sales" columns at the price on that day.

\* "Total" is assumed to represent the proper total of day by day figures.

**SHEET No. 3**

**FEED COSTS**

November, 1919, Total bills for feed.....	\$ 716.66	November 30, 1919, Feed on hand:	
January, 1919, Pullets.....	1298	12 Sacks Wheat, 1560 lbs.....	\$ 62.40
March, 1919, Pullets.....	1859	10 Sacks Corn, 1000 lbs.....	40.00
	3157	20 Sacks Mash, 1600 lbs.....	56.00
		Total on hand.....	\$ 158.40
		Difference, Cost of November feed.....	558.26
			\$ 716.66

Total Layers as per Sheet 1:--	3157	558.26(17-6+
January, 1919, Pullets.....	1298	Say 17-7c per hen.
March, 1919, Pullets.....	1859	
	3157	

December 1, 1919, Feed on hand.....	\$ 158.40	Repeat as in November.
December 31, 1919, Total bills for feed.....	817.22	
	\$ 975.62	

**SHEET No. 4**

**EARNINGS PER HEN**

November, 1919

Stock As per Sheet 1	Number of Hens As per Sheet 1	Eggs Laid As per Sheet 2	No. of dozens	Value of Eggs	Feed for Yard	Profit from Yard	Profit per Hen	Eggs per Hen
January, 1919.	1298	12980	1081 2/3	(1081 2/3 × 60c) \$649.00	(1298 × 17-7c) \$229.74	\$419.26	(419.26 ÷ 1298) 32 1/4c	(12980 ÷ 1298) 10
March, 1919 ..	1859	18590	1549 1/3	(1549 1/3 × 60c) \$929.50	(1859 × 17-7c) \$329.04	\$600.46	(600.46 ÷ 1859) 32 1/2c	(18590 ÷ 1859) 10
Totals.....	3157	31570	2630 5/6	\$1578.50	\$558.78	\$1019.72		

There will always be a difference between "Value of Eggs" herein and in "Egg Record" because of eggs remaining on hand unsold on last day of month.  
 A difference will also appear between total of "Feed for Yard" and the "Feed Account" because of dropping decimals.  
 These differences are of no importance.

### Rules for Success

The writer has often been asked what the requisites are for success in egg-farming. This may vary with different individuals. So far as his success is concerned he attributes it to:

First, never getting tired; never being too tired to do something that will add to the comfort and well-being of the birds.

Second, mastering the art or science of brooding chicks and raising large numbers of pullets.

Third, renewing at least 60 per cent of the flock each year with young pullets.

Fourth, concentrating on one particular branch of the work and keeping everlastingly at it.

Fifth, keeping accurate records and accounts so that he knows at every stage of the work what the results are in dollars and cents.

Sixth, asking the giver of advice for his practical experience on a commercial scale before acting on it.

Seventh, disregarding the clock so far as the 8-hour day is concerned and working not only hard, but efficiently, so that every minute is made to count and neither time nor effort is wasted.

### Profits Derived in 1918

Our gains and losses during the year 1918 were as follows:

Received from sale of eggs.....	\$22,325.03	
Received from sale of fertilizer	300.70	
Total gains .....		\$22,625.73
Feed and Supplies .....	\$ 9,623.46	
Hired Labor .....	1,419.45	
Water Taxes (Including household use) .....	103.40	
Sundry Farm Expenses.....	161.54	
Interest Paid, and all Taxes.....	930.82	
Total losses .....		12,238.67
Difference—Gain for the Year..		\$10,387.06

Against this gain is a **charge** for depreciation on buildings and income taxes for 1918 payable in 1919. There is an additional **gain** by reason of the fact that there was a net increase in the flock of 632 above mortality.

The reader who analyzes these figures carefully will readily find the answer to the question of how this great profit was made. The writer, with the help of one man constantly 6 days in the week; another man for a short time during the brooding-and-heavy-laying season; and a third man coming in for one day every ten days to do the cleaning, **did all the work**. More than three thousand pullets were raised in the spring of 1918; and when the maximum hired help was on duty **between 10,500 and 11,000 birds**, young and old, were being cared for.

The hired help worked eight hours a day. The writer worked until the work was done; 16-hour days were common during the brooding-season, and 24-hour days sometimes happen.

It is a man's-sized job.





# INDEX

---

	Page		Page
Acresage needed.....	17	Co-operative marketing .....	132
Alarm system.....	46-70	Cost of: Buildings .....	65
Alfalfa .....	39-119	Chicks .....	28
Anatomical tests .....	143	Feeding .....	125
Awnings .....	48	Raising pullets .....	28
Baby Chicks: Caring for.....	69	Crossing breeds .....	22
Carrying .....	67	Cross section of laying house.....	54
Hatching .....	66-133	Crying chicks .....	76
Balancing feed .....	85-119	Culling .....	110-171
Barley .....	135	Culls .....	110-114-173
Bowel trouble .....	96-158	Danger periods .....	92
Blue combs .....	148	Dead chicks .....	93
Breeding plan .....	137	Designation of chickens.....	146
Breeding stock .....	112-114-137	Diagram of our plant.....	40
Breed to keep.....	21	Diarrhoea .....	95
Broilers .....	113-146	Diphtheria .....	158
Broken eggs .....	129	Discolored comb .....	143
Bronchitis .....	150	Diseases of chicks.....	91
Brooder houses .....	43-48	Diseases of chickens.....	147-150
Brooding system .....	69	Disinfecting .....	16-134
Broody coops .....	61	Disinfectants .....	134
Buildings: Avoid fads.....	13	Disturbances .....	123
Cost of .....	65	Doctoring chicks .....	93
How to face.....	13	Double fences .....	19
Type of .....	13	Double yards .....	117
Type we use.....	43	Douglas Mixture .....	92-159-162
Using old ones.....	15	Droppings .....	135-148
Bumblefoot .....	150-157-167	Dropsy .....	150-156-166
Buying partly developed chicks.....	101	Dry mash .....	118
Buying pullets .....	35	Eggbound .....	150-157-167
Calling the birds.....	124	Egg room .....	42-64
Canker .....	150-152-163	Egg yield per hen.....	139
Capital required .....	28	Eggs: Cooling .....	130
Carrying baby chicks.....	67	Gathering .....	128
Catarrh .....	150-151	Grades .....	129
Cats .....	101	Grading .....	129
Chicken pox .....	150-152-163	Marketing .....	131-133
Chick feed .....	72	Packing .....	129
Chick mash .....	81-83	Retailing .....	131
Chick troughs .....	81-87-107	Selecting for hatching.....	68-137
Chilling .....	90-93-96	Electric lights .....	141
Cholera .....	158	Fall hatching .....	24
City locations .....	11	Feed: Balancing .....	119
Cleaning .....	100-134	Costs .....	125
Clogged crops .....	150-156-166	House .....	39-64
Closing houses at night.....	118	Pails .....	82-121
Closing nests .....	129	Weighing .....	85-119
Coccidiosis .....	96	Feeding: Chicks .....	70
Cockerel house .....	48-112	Broody hens .....	125
Cockerels: Selecting .....	102-113-137	Cockerels .....	111-115
Selling .....	114	Indoors .....	121-124
Cocks .....	146	Laying hens .....	118
Colds .....	96-109-150-162-165	Outdoors .....	90
Combs indicate health .....	148	Time of .....	119
Comparative production .....	142		
Cooling eggs .....	130		

## INDEX — Continued

	Page		Page
Fences .....	47-62	Marketing: Broilers .....	114
Freshening yards .....	29-135	Eggs .....	131-133
Frights .....	77-123-145	Co-operative .....	132
Fryers .....	146	Hens .....	138
Gate latches .....	53	Mash: Formula .....	118
Gates .....	42-63	Troughs .....	54-58
Gathering eggs .....	128	Wet .....	121
Getting ready for chicks .....	70	Mating .....	137
Grading: Broilers .....	114	Medicines .....	158
Eggs .....	129	Method of feeding .....	119
Hens .....	139	Mites .....	100-169
Grain mixing .....	123	Mixing grain .....	123
Grains used .....	122	Mortality: Chicks .....	91
Greenstuff .....	83-119-135	Hens .....	170
Greenstuff, space for .....	21-48	Moult .....	121
Grit .....	119	Moving pullets .....	105
Hatching .....	66-69	Nests .....	54-59
Hatching: Fall .....	24	Nest material .....	145
Spring .....	24	No-yard system .....	16
Time for .....	24	Number of hens in house .....	105-117
Hatching eggs:		Opening the nests .....	129
Selecting .....	68-137	Packing eggs .....	129
Selling .....	133	Parasites .....	100-169
Health—indications of .....	148	Peewee eggs .....	130
Hens .....	138-146	Pepper .....	167
Hens per acre .....	17	Percentage of chicks raised .....	91
Housing the layers .....	117	Percentage of pullets raised .....	91
Hospital quarters .....	43-63	Piling up .....	109
Indications of health and disease .....	148	Plan of our plant .....	37
Indigestion .....	94	Ploughing .....	135
Individual treatment .....	165	Profitable age of hens .....	138
January hatching .....	25	Profit to be expected .....	22
January pullets .....	103	Prolapsus of oviduct .....	150-157-166
Keeping accounts .....	173	Puffy crops .....	94
Keeping hens indoors .....	118	Pullets .....	146
Lath ladders .....	107	Pullet eggs .....	130
Laying houses .....	51-54	Reducing heat in brooder house .....	74-83
Laying mash .....	110-118	Retailing eggs .....	131
Laying out the plant .....	17	Rheumatism .....	157-168
Leg weakness: Chicks .....	93	Roasters .....	146
Hens .....	150-157-168	Roosts for chicks .....	45-105
Lice: Cockerels .....	169	Roup .....	152-158
Hens .....	169	Rules for success .....	178
Young chicks .....	100	Salts .....	93-159-162-168
Limberneck .....	150-156-166	Scaly leg .....	169-170
Litter .....	70-127	Segregating cockerels .....	90-137
Liver trouble .....	150-157-166	Selecting: Breeding cockerels .....	102-113-137
Locating an eggfarm .....	9	Hatching eggs .....	68-137
Manure: Disposition of .....	135	Hens .....	138
Value of .....	135	Selling: Baby chicks .....	133
Weight of .....	135	Broilers .....	113
		Co-operative .....	132
		Hatching eggs .....	133
		Hens .....	138

## INDEX — Continued

---

	Page		Page
Shell .....	119	Vaccination .....	163
Size of eggs .....	25-144	Visitors .....	77-124
Soda .....	79-94-159-163-168		
Soil best adapted .....	12	Watering broody hens .....	62
Spraying .....	100-134	Watering chicks .....	72
Spring hatching .....	24	Watering device: Chicks .....	72
Sprouted oats .....	87	Hens .....	58
Sprouting oats .....	127	Water pots—care of .....	128
Starting small .....	33	Water shed .....	57
Stags .....	146	Weighing the feed: Chicks .....	85
Surveying .....	18	Hens .....	119
Swollen eyes .....	151	Weight of manure .....	135
		Wet mash .....	121
Taking out cockerels .....	90-102	When to sell hens .....	138
Time of feeding .....	119	When to start .....	24
Time of hatching .....	69	Where to feed .....	123
Toe-picking .....	75-94	Where to locate .....	9
Training the cat .....	101	White diarrhoea .....	95
Trapnesting .....	143	Worms .....	169-170
Treatment of disease .....	161		
Trees .....	21	Yard: Freshening .....	29-135-136
Troughs: For chicks .....	81-87-107	Gates .....	42-63
For hens .....	54-58	Our plan .....	40-62
Tumors .....	150-156-166	Space needed .....	17
Turning off the stove .....	104	Yards .....	16-17
Two-hundred egg hens .....	141	Yards or no-yards .....	16
		Yield per hen .....	139
Use of brooder yards .....	89		
Using rented place .....	29		









