

1921.

WESTERN AUSTRALIA.

---

The Handbook  
of  
Horticulture and  
Viticulture  
of  
Western Australia.

---

By A. DESPEISSIS, M.P. 'C.

---

THIRD EDITION.

---

PERTH

BY AUTHORITY: FRED. WM. SIMPSON, GOVERNMENT PRINTER.

1921.

@  
SB 357  
I 46

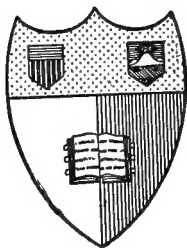

New York  
State College of Agriculture  
At Cornell University  
Ithaca, N. Y.

---

Library

---

Cornell University Library

SB 357.D46

The handbook of horticulture and viticul



3 1924 003 326 539

mann

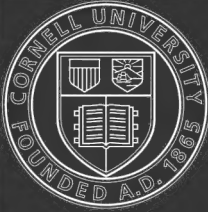

# Cornell University Library

The original of this book is in  
the Cornell University Library.

There are no known copyright restrictions in  
the United States on the use of the text.



1921.

WESTERN AUSTRALIA.

---

The Handbook  
of  
Horticulture and  
Viticulture  
of  
Western Australia.

---

By A. DESPEISSIS, M.R.A.C.

---

THIRD EDITION.

---

PERTH:

BY AUTHORITY: FRED. WM. SIMPSON, GOVERNMENT PRINTER.

---

1921.

@  
SB 357  
D 46

@ 29323

## ERRATA.

---

“After the book left the Government Printer, and before distribution, the following errata were noticed, and it is desired to draw the reader’s particular attention to the corrections and additions on this page.”

Page 21.—Flooded or “Blue Gum” read (*E. rudis*) not (*E. Salinga*).

Page 21.—Jam (*Acacia acuminate*) should read (*Acacia acuminata*).

Page 21.—Delete “Manna Gum” (*E. Viminalis*, *La Billardieré*).

Page 21.—Spearwood (*E. Doratoxylon*, F. Von Müller) should read (*Jacksonia sternbergiana*).

Page 21.—Zamia (*Cycas sp.*) should read (*Macrozamia Fraseri*).

Page 175.—Second line from bottom, delete “inches” after “six” and insert “feet.”

Page 492.—Tenth line from bottom, “*oxydase*” should read (“*oxydasi*”), and insert before “through” the words “in the enzyme.”

Page 573.—Eighth line from bottom, “*B. solannicola*” should be “*B. solanicola*.”

Page 576.—Twenty-second line, “*Meso termis Darwini*” should read “*Mastodermes darwiniensis*.”

Page 580.—First line, delete words “in addition so secreting a honeydew.”

Page 581.—Eleventh line from bottom, after “*repanada*” add “*syn. Coccinella transversalis*.”

Page 583.—Fourth line, delete word “flies,” read in lieu “wasps.”

Page 584.—Twelfth line, from “cabbage” delete words “the inner leaves are seldom attacked though larvæ may occasionally be seen in the heart itself, the damage is usually to the outer leaves; with,” and add the word “and” before “cauliflower,” in the 8th line from bottom.

Page 585.—Third line from bottom, the word “*Hemiptera*” should read “*Hemiptera*.”

Page 586.—First line, “*Anoplosthetus*” should read “*Anoplostethus*.”

Page 587.—Fifth line, “*Centonides*” should read “*Centonides*.”

Page 588.—Fifteenth line, “*Colombyforma*” should read “*Colombymorpha*.”

Page 590.—Fifteenth line, “*armigera*” should read “*obsoleta*.”

Page 591.—Fifth line, after the word “successful” add “total prohibition reimposed 21st September, 1912.”

Page 592.—Nineteenth line, after the word “season” add “owing, however, to the longer season two broods have been proved in Western Australia.”

Page 592.—Thirtieth line, after the word “with” add “in Western Australia the first brood moths emerge September, October; second brood December, January.”

Page 594.—Fourth line from the bottom, delete “summer” and read in lieu “December.”

Page 598.—Twenty-eighth line, “Leptos” should read “Leptops.”

Page 601.—Sixth line, delete words “they vary in.”

Page 601.—Seventh line, delete words “and usually.”

Page 602.—Twenty-seventh line, delete words “fairly wet ground,” and insert in lieu “in well-drained soils watered during summer.”

Page 604.—Fourth line, add “*syn. Pthorimaea operculella.*”

Page 604.—Eleventh and twelfth lines, delete words “occasionally seen on tomatoes,” and insert in lieu “a serious pest of tomatoes and Cape gooseberries.”

Page 606.—Second line from bottom, “Symnus” should read “Seymnus.”

Page 607.—Twenty-eighth line, after “find” add “until recently.”

Page 611.—Fifteenth line, add “(Note: *Scutellista cyanea* is now well established in Western Australia).”

Page 614.—Fourth line from bottom, add “attacks and controls Red Scale in Western Australia.”

Page 617.—Third line, after “scale” add “(*Aphelinus fucipennis*).”

Page 621.—Illustration “Strawberry Beetle” should be “Strawberry Bug.”

Page 626.—Twenty-fifth line, after word “fly” add “once the eggs are deposited.”

Page 627.—Fifth line from bottom, “*Louchoea*” should read “*Lonchaea*.”

Page 630.—Transpose names “*Orcus Australasiae*” and “*Chilomenes quadrapustulatus*.”

Page 632.—Plate inserted in error. Correct illustration page 256.

## PREFACE TO THE THIRD EDITION.

---

The increasing demand for the "Handbook of Horticulture and Viticulture of Western Australia," and the fresh stimulus given to land settlement under the scheme of the Repatriation of Returned Soldiers, have made it desirable for the Department of Agriculture to bring out a new edition.

The subject matter dealt with in the first two editions has in the third been carefully revised, and much additional information included.

In collating the mass of information which will be found grouped within the several chapters of this Handbook I have, as far as possible, acknowledged the sources whence that information was derived; and the value of those sources, together with the personal experience I have been able to gain in questions dealt with in the following pages, will, I hope, be of some benefit to those who may consult this book.

A. DESPEISSIS, M.R.A.C.

Department of Agriculture,  
Perth, W.A., 10th February, 1921.

CONTENTS.

	PAGE
Introductory ... ..	1
Western Australia as a Fruit Land ... ..	3
Our Soils ... ..	13
Ringbarking and Clearing Land ... ..	20
Preparing Land for Planting ... ..	34
Drainage ... ..	39
Shelter Trees ... ..	44
Fencing ... ..	51
Laying out the Ground ... ..	56
Planting and Cultivation ... ..	63
Grafting ... ..	89
Budding ... ..	119
Pruning ... ..	126
Vine Pruning ... ..	131
Fruit Tree Pruning ... ..	147
Summer Pruning and Thinning of Fruit... ..	180
Manures and Manuring ... ..	187
Irrigation and Root Management ... ..	210
What Fruit to Grow ... ..	225
Small Fruits ... ..	305
Tropical Fruits ... ..	324
Fruit Drying ... ..	345
Drying Vegetables ... ..	358
Fruit Candying ... ..	359
Canning and Fruit Pulp ... ..	363
Pulping Fruit ... ..	367
Jellies ... ..	369
Gathering and Marketing Fruit ... ..	370
Wine Making ... ..	400
Unfermented Grape Juice ... ..	496
Vinegar from Wine and from Cider ... ..	500
Infertile Grape Vines ... ..	508
Insect and Fungoid Pests ... ..	514
Garden and Orchard Crops, their pests and remedies ... ..	519
Plant Fumigation ... ..	541
Fungus Diseases ... ..	547
Description of Insects, injurious and beneficial ... ..	574

# THE HANDBOOK

OF

## HORTICULTURE AND VITICULTURE

OF

### WESTERN AUSTRALIA.

---

BY A. DESPEISSIS, M.R.A.C.

---

**T**HE awakening of Western Australia as a fruit-producing State dates only from the beginning of the gold rush a couple of decades ago. It is concurrent with the development of the wonderful gold belt which has since been proved to run through it, from the Great Australian Bight, in the South, to Cambridge Gulf and the tropical Kimberleys, in the North.

Previous to that epoch, sufficient had been achieved by the older colonists to show that Western Australia could produce grapes and fruit of great excellence, but the gardens of the State were few in number and far apart. Yet, fruit was then more easily procurable than it has since been, and the requirements of the 50,000 odd consumers were liberally satisfied; indeed, fruit was then so cheap that no market value was attached to it. It was mostly consumed on the spot, and the surplus rotted under the trees, and was not worth carting away. In those days consumers were producers themselves; long distances and lack of rapid communication militated against the marketing of fruit, and methods of picking and packing for distant markets were not familiar to fruit-growers, nor had they any experience regarding those varieties which, better than others, lend themselves to long keeping and travelling.

With the discovery of gold came the rush of gold-seekers. The constant stream of population which then set in soon taxed the resources of the farming districts; supplies of all sorts were soon exhausted, and all the commodities of life had to be largely imported. The ever-increasing flow of population continued its course to the inland goldfields.

Every new-comer proved a consumer. Even the settlers deserted their farms and rushed to the arid interior in quest of gold. Famine prices were offered and given for all products of the soil. Then a new current set in, and whilst the main stream of population continued to pour into the Coolgardie and the Murchison gold-fields, a smaller stream spread over the moister coastal districts. Gold was to be won from the ploughed fields as well as from the quartz reefs.

A great many may claim to have first discovered that Western Australia was teeming with gold, but the pride of having discovered that the State was teeming with latent horticultural and agricultural wealth must belong to the proprietors of the *West Australian* newspaper. At their instigation, the late Mr. L. Lindley-Cowen set out on a voyage of discovery through the agricultural districts of what is known as the South-West Division of Western Australia—a province covering an area of country 350 miles from North to South by 100 to 200 miles from West to East. From every point of that territory which he visited Mr. Cowen, in a series of articles which at the time attracted attention, as well as enlightened the settlers, old and new, described the achievements of the pioneer agriculturists of the country, and prognosticated the era of wonderful development which every branch of agriculture has since entered upon.

That Western Australia bids fair to eclipse the other States of the group as a fruit-producing territory is firmly believed by all who have paid any attention to the circumstances which favour or retard fruit-growing as an industry. Its soil is virgin, and for ages without number has supported gum trees and shrubs of various sorts without a rest, and been fouled by their residues, until at last it welcomes fruit-trees, with the same eagerness as does a corn sick field some other crop in the course of the rotation.

Its climate is consistent and not capricious. When going beyond well-defined and moist zones for the purpose of starting fruit-growing, the settler has himself to blame for courting failure unless he can counteract the unreliable rainfall by artificial irrigation. Anyhow, his crops are not periodically threatened of destruction by hail-storms, such as are at times experienced in other parts of Australia.

Untrammelled by errors which, in the Eastern States, have defeated the aims of the earlier fruit-growers, and proved a source of loss to them, Western Australian growers start with the experience of others, and are reaping the fruit of the knowledge dearly bought. Thus they are able with comparatively few faults to start a clear course on embarking into fruit-growing on commercial lines.

This State besides possesses amongst all Australian States the incalculable advantage of being from 1,200 to 2,000 miles nearer the European markets; or, in other words, its perishable fruit



crops, because of its geographical position, are produced from four to eight days nearer the consumer's table.

Another advantage of no mean importance is that the population of Western Australia—very small until the discovery of gold—has since been increasing steadily and rapidly, as the mineral and agricultural resources of the country are being developed. Such indeed are the demands of the local market that a ready sale, at a profitable price, is obtained for all fruit of good quality; and, whilst preparing for extensive fruit export, the grower is enabled to dispose locally at highly remunerative prices of small parcels of fruit he may gather from his young trees.

### WEST AUSTRALIAN FRUIT LAND.

From Cambridge Gulf, in the tropical North, to the Great Australian Bight, in the temperate Southern regions, Western Australia unfolds a coast line of over 1,200 miles capable of growing, according to latitude or elevation, some sort of fruit or other.

Under the regulating influence of the monsoons, the rainy season follows the dry one with almost clockwork precision; and thus, within the coastal zone, the grower knows what to expect, nor is he confronted either by a sweeping deluge or a prolonged drought from one season to the other.

Farther inland great waterless tracts of fertile land occur, which, with the spread of settlement, disclose favoured spots without number where artificial irrigation is rendered possible, and where fruit-growing offers great possibilities.

In this handbook no reference will be made to that part of Western Australia extending from the Kimberley districts on the North to the latitude of the Murchison River 28deg. S.

Few settlers, hitherto, in that vast stretch of country, until recently given almost entirely over to pastoralists, have paid systematic attention to horticulture. The cause is easy to discover. Few, if any one, of those who in the past have lived at the Nor'-West and the North of this State have had any idea of permanently settling down. Whilst there their whole attention has been engaged in more or less nomadic occupations; the small cultivated patch has proved sufficient to supply the requirements of the homestead, and no inducement had until now offered to plant largely, owing to the lack of frequent and quick means of communication with the markets of the South. Sufficient is, however, known to state that at several places where facilities offer for irrigation, or where the soil is naturally moist, the cultivation of tropical plants and fruit trees has been attended with such success as points to great possibilities in that direction.

One of the most successful undertakings of that nature is that of the Trappists' Mission at Beagle Bay, about 21deg. lat. S., where some 10 acres have been planted, chiefly with bananas, mangoes,

guava, figs, tamarind, date palm, cocoanut trees, oranges, and lemons, which all thrive well.

In a report on the capabilities of the East Kimberley district, Mr. R. Helms, then biologist of the Bureau of Agriculture, said:—

“The greatest prosperity of the country will begin when the cultivation of specially tropical products is taken up in earnest. It will then be that the country becomes populated, for a couple of hundred acres, well tilled and planted with suitable crops, enables a man to acquire an independency. The country possesses not only the rare advantage of being perfectly healthy, but the land best suited for the growth of tropical products is free from timber. It, therefore, requires no coloured labour to produce cotton, sugar, cocoa, tobacco, rubber, or fibre, and other profitable articles of commerce. Europeans can do the work, and no great capital is required to prepare the land, the grubbing of trees in a tropical forest being always a great expense. Moreover, irrigation can be carried out at a minimum of expense. In a number of places it will be found that water can be conserved in such a way as to enable large areas to be watered by gravitation; but where that method is impracticable, windmills may effectively be employed, as a steady breeze generally blows throughout the day.”

My own observations made in the course of official explorations to ascertain the agricultural capabilities of the North-West and of the tropical Kimberleys lead me, with some reservations, to support these views, and whenever population is attracted to these little known provinces of Australia important settlement may be looked forward to in favourable places where easy transport and communication are provided.

The section of Western Australia that will be more particularly considered in this handbook is that comprised between the Murchison River, 50 miles North of Champion Bay, lat. 28deg. S., to King George's Sound, lat. 35deg. S., and an imaginary line enclosing a somewhat triangular-shaped territory, about 50 miles broad at the Murchison end to 300 miles at its base, from the Leeuwin to Esperance.

Such area is shown on the maps issued by the Lands Department of Western Australia as the South-West Division.

That a great extent of this country is admirably suited for vine and fruit growing is abundantly demonstrated by the success which has accompanied the enterprise of settlers in the various districts of the State.

The variety of climatic conditions and soil make it possible to grow in this division of Western Australia almost any fruit of the cool-temperate as well as semi-tropical climates.

A better understanding of the requirements which underlie the pursuit of modern fruit-growing—one of the most interesting and profitable branches of agronomy—brings out several features in the

West Australian climate which point to the particular suitability of this country for fruit-growing.

For the purpose of illustrating this statement, no more convincing means offer than comparing the climate of the South-West Division of this State with the climate of some of the most noted fruit districts of the world, and especially California, in—1st, temperature; 2nd, light; 3rd, air humidity; which are all climatic conditions, absolutely necessary to fruit ripening. According as these three conditions are met with in a more or less suitable degree the fruits ripen with greater or less perfection.

#### TEMPERATURE.

When compared with the chief fruit-growing districts of California, the West Australian climate shows to advantage, its chief characteristics being—1st, freedom from extremes of low and high temperature; 2nd, an abundance of sunshine; 3rd, summer atmosphere, with a low percentage of humidity.

The following table, which gives the *lowest* thermometric readings during a period of five years, at six places which can well serve as land marks in dealing with the fruit-growing districts of this State, compares favourably with some Californian stations where fruits of the citrus tribe, for instance, are known to attain to great perfection:—

	Deg. Fah.		Deg. Fahr.
Geraldton ...	... 38	San Francisco ...	... 28
Perth ...	... 32	San José ...	... 22
Bunbury ...	... 35	Los Angeles ...	... 28
Albany ...	... 32	San Diego ...	... 32
York ...	... 29	Sacramento ...	... 19
Katanning ...	... 27	Fresno ...	... 18

If, on the one hand, temperature must not be too low for the profitable cultivation of trees such as those belonging to the citrus tribe, which retain their foliage all the year round, it must not, on the other, rise to too high a degree in the summer months without exposing the trees to sun scald.

Careful experiments made tend to demonstrate the fact that “a temperature above a certain minimum of heat is found necessary for germination, another for chemical modification, and a third for flowering, a fourth for the ripening of seeds, a fifth for the elaboration of the saccharine juices, and a sixth for the development of aroma or bouquet.”

The same botanist who laid down the above rule (Boussingault) determined that, in the case of the grape vine, while a mean of 59deg. Fahr. during the growing months will allow the plant to flourish, a much higher mean temperature is necessary during the summer and autumn months from the time the seeds are formed until full maturity, to bring the fruit to perfection, and there must

be a month the mean temperature of which should not fall below 66.2deg. Fahr.

The following table gives the average *summer* temperature during the growing months at various Western Australian and Californian points:—

	Deg. Fahr.		Deg. Fahr.
Geraldton ...	... 75.5	San Francisco ...	... 59.4
Perth ...	... 72.9	San José ...	... 56.2
Bunbury ...	... 70.5	Los Angeles ...	... 69.7
Albany ...	... 67.3	San Diego ...	... 68.4
York ...	... 77.2	Sacramento ...	... 71.4
Katanning ...	... 72.1	Fresno ...	... 84.1

These tables show that, compared with the most noted Californian fruit-growing centres, the South-Western Division of Western Australia is possessed of a summer climate warm enough for the growth of any of the fruits of temperate zones; while the winter never severe enough to frost-kill these fruits, is, however, sufficiently cold to insure for them the three or four months of rest they need.

With the exception of Albany and similarly situated localities, abundant warmth occurs for the ripening of all kinds of grape vines, of all temperate climate fruit, a most exacting one as regards warmth. Even in Albany, the early grapes do ripen, unless exposed to the chilling Southern breeze; while only a few miles inland the later-growing grapes as well reach maturity. Elsewhere, such as in the northern portion of the Eastern division on the eastern side of the Darling Ranges, the great excess of summer temperature over that absolutely required for the proper maturing of the grapes results in higher sugar formation in the juice. When to this higher summer temperature is associated a longer growing season, we find combined the elements conducive to the production of a second crop.

#### LIGHT.

Light also plays an important part in the perfect maturation of fruit, and an abundance of it, in conjunction with a congenial degree of atmosphere, results in better flavoured fruit, and in the better development of the colour, bouquet, and aroma.

Reference to the information supplied in the meteorological reports of the State, for a series of years, testifies abundantly to the fine and bright state of the atmosphere during the summer and autumn months at the stations mentioned above. On the faith of the same reports, we find that Albany is the locality with the smallest number of cloudless days during those growing months; while Bunbury, which comes next as regards a low mean summer temperature, as given in the above tables, is reported to have during the growing months an almost continuous succession of bright, cloudless days, which are conducive to sugar production. Thus it is seen that, although the temperature in the district around Bun-

bury is fairly cool in the summer months, yet the great purity of the atmosphere is favourable to the perfect maturation of grapes as the plant profits during those months by its full share of the chemical effect of the direct rays of the sun.

Viewed in the light of practical fruit growing, abundance of cloudless days in connection with high and protracted heat, results in high sugar production, which is of great advantage in the production of raisin and prune, and also in the successful ripening of a second crop of grapes in a season.

It is thus shown why wine for instance, made from grapes produced from cuttings of the same varieties, and perhaps obtained from the same parent vines, but grown in a hot and clear district, in the one instance, to another wine from similar variety of grapes grown in a cooler locality possessed of an atmosphere not so bright and clear, will present to the palate and to laboratory tests quite different characteristics. If, for instance, we take Malbec or Cabernet as an example, they will produce a rounder and stronger wine in the first district, and a wine of a lighter character and more of the claret type in the cooler localities: for, in the process of wine-making, sugar means alcoholic strength.

In order to continue the parallel between Western Australian and Californian climates, and also the climate of other States of America, the following table is given to compare the relative degree of sunshine at various places mentioned below.

In this table cloudiness is rated from 0 to 10; two observations are taken daily at 9 a.m. and 3 p.m.

Geraldton	...	...	2.7	Sacramento, Cal.	...	2.0
Lawlers	...	...	3.1	San Francisco, Cal.	...	4.0
Kalgoorlie	...	...	3.4	Fresno, Cal.	...	2.1
York	...	...	3.0	San Diego, Cal.	...	4.2
Perth	...	...	4.4	New York, N.Y.	...	5.0
Bunbury	...	...	5.5	Philadelphia, Pa.	...	5.0
Katanning	...	...	5.2	New Orleans, La.	...	4.5
Albany	...	...	5.0	Jacksonville, Fla.	...	4.5

#### VALUE OF DRY AIR.

For the purpose of fruit-growing, it can safely be stated that a moderately dry air, especially during the summer and autumn months, is in many respects more desirable than a vapour-laden atmosphere.

In the first case, pests, and blights of fungus origin—moss, lichens, etc.—are not anything like so troublesome as in more humid localities.

The oïdium of the vine, for instance, is much more troublesome in moist than in dry seasons; and, for the same reason, in the moist air districts close to the sea, than in districts situated further inland, where the atmosphere is drier.

For another reason is dry air of value to the fruit-grower. It favours the better penetration through the atmosphere of heat and light, and their access to the plant. The effect of the chemical rays of the sun, which, although not appealing to our senses in the same measure as its thermal rays, are nevertheless essential in bringing about the perfect ripening of fruit. Now, a layer of vapour-laden atmosphere floating over the earth acts as a screen, which, although pervious to the heat rays, shuts off in a great measure the chemical rays of the sun. A practical illustration of this fact has been noticed by everyone. However hot the season, fruit will ripen slowly and rot on the plant if the atmosphere is dull, moist, and muggy; whereas in a dry and bright autumn, fruit will be correspondingly luscious and richly flavoured, and will put on the brightest of those tints of colour by which each variety is differentiated from the other.

MEAN MONTHLY RELATIVE AIR HUMIDITY—AUGUST TO APRIL—  
AND MEAN ANNUAL. (SATURATION = 100.)

—	Aug.	Sept.	Oct.	Nov.	Dec.	Jan.	Feb.	Mar.	Apr.	Mean Annual (12 Mths).
Geraldton ...	74	74	72.6	70	75	73.6	67	72.6	67	71.6
York ...	71.6	73	66	53.3	59	54.3	53.3	63.6	54	63
Perth ...	73.6	69	69	63.6	63.3	61.6	62.3	60.3	61.3	66.2
Bunbury ...	75	76	73	67.6	65.3	68.3	68	71.3	72.3	73
Albany ...	77.3	77.6	77	72.6	80.3	74.3	80.6	75	75.3	76

—	Apr.	May.	June.	July.	Aug.	Sept.	Oct.	Nov.	Mean Annual (12 Mths).
Los Angeles ...	73.1	75.2	73	75.4	76.2	72.9	74.3	66.6	73.3
Fresno ...	59.3	52.7	42.7	34.7	34.7	43.6	55.1	64.1	48.3
Sacramento ...	67.6	67.6	66.1	58.9	59.8	59	62.4	66.8	63.6

#### THE RAINFALL AND WATER SUPPLY.

The rainfall of the zone running along the sea-coast of Western Australia for a distance of 80 to 100 miles from the coast is regular and reliable. More abundant in close proximity to the seashore, and also on the higher tableland of the Darling Ranges which fringes the coast-line some twenty miles inland for a distance of about 300 miles, the rainfall gradually decreases the farther inland we go.

Practically, there are only two seasons, the "dry" and the "wet." Both are influenced by monsoonal action. In the Northern part the wet season sets in during the summer months, commencing in November and lasting till April. During that time smart cyclones, locally called "willy-willies" and "cock-eyed bobs," at times

sweep over the land, causing occasionally damage to stock and property. These cyclones are more frequent north of Broome than south of that place, where they mostly strike the coast and do not extend their influence far inland. In the South, from the Murchison River to the Leeuwin, the wet season, on the other hand, sets in after Easter, generally May, lasts through the winter and ends in October, with a few occasional showers during the summer months. During those winter months the weather is made up alternately of heavy showers and clear, sunny intervals. Ninety per cent. of the rain falls on an average in these six or seven months. In the South-Western corner the moisture-laden clouds which are carried on one side over the Southern Ocean, and the other over the Indian Ocean, impinge over the range of mountains which rise a few miles from the coast-line, and runs parallel with it for a distance of over 300 miles, and there dissolve into heavy rain. Once blown over these ranges, farther to the eastward, these moisture-laden clouds meet with no obstruction to bring about their precipitation, and thus are carried away into the vast unsettled interior, where the farther from the coast the drier is the climate.

The following table gives the average rainfall in Western Australia at points located in the several divisions of the State:—

Locality.	Height above Sea Level.	Average No. of Wet days.	Average Rainfall, in Inches.	No. of Years of Average.
<i>East Kimberley—</i>				
Wyndham ... ..	...	55	27	32
Hall's Creek ... ..	...	...	21	28
<i>West Kimberley—</i>				
Derby ... ..	...	...	27	33
Broome ... ..	...	65	24	29
<i>North-West Division—</i>				
Wallal ... ..	...	...	13	22
Port Hedland ... ..	...	24	13	21
Roebourne ... ..	...	20	12	32
Onslow ... ..	...	25	8·7	33
<i>Gascoyne Division—</i>				
Carnarvon ... ..	...	...	9·3	36
Sharks Bay ... ..	...	...	9·2	25
Hamelin Pool ... ..	...	...	7·9	33
Wooramel ... ..	...	...	8·9	20
<i>S.W. Division—</i>				
Abrolhos ... ..	25	50	13·4	22
Northampton ... ..	...	52	20	37
Geraldton ... ..	15	80	18·6	41
Dongara ... ..	30	70	19	26
Yandanooka ... ..	...	...	18	11
Carnamah ... ..	880	66	16	31

AVERAGE RAINFALL—*continued.*

Locality.	Height above Sea Level.	Average No. of Wet days.	Average Rainfall, in Inches.	No. of Years of Average.
Dandaragan ... ..	...	80	26	31
New Norcia ... ..	600	...	21	36
Moora ... ..	...	75	18.5	21
Wongan Hills ... ..	...	...	17	6
Gingin ... ..	...	...	30.5	30
Rottnest ... ..	...	94	32	10
Perth ... ..	...	110	34	43
Kalamunda ... ..	...	...	42	10
Guildford ... ..	30	91	33	39
Rockingham ... ..	...	95	33	21
Toodyay ... ..	470	...	21	39
Dowerin ... ..	...	...	15	14
Northam ... ..	491	80	16.7	38
Kununoppin ... ..	...	...	13.3	6
Tammin ... ..	730	...	14.3	7
Kellerberrin ... ..	807	68	13	26
York ... ..	580	88	17.5	42
Narrogin ... ..	1,114	...	19.5	...
Wickepin ... ..	...	...	16.7	7
Williams ... ..	...	...	21	34
Wagin ... ..	840	80	17.5	28
Katanning ... ..	1,022	90	18	27
Kojonup ... ..	...	90	22	34
Bridgetown ... ..	505	...	33.7	31
Canning Waterworks ... ..	...	...	41	31
Jarrahdale ... ..	128	...	45.8	36
Pinjarrah ... ..	28	...	38	40
Marradong ... ..	...	80	28	21
Wickepin ... ..	...	92	17	7
Collie ... ..	604	...	38	19
Bunbury ... ..	18	...	36	42
Busselton ... ..	...	...	31.4	38
Cape Leeuwin ... ..	...	...	37	22
Boyanup ... ..	123	...	33	23
Karridale ... ..	...	...	49	25
Cape Leeuwin ... ..	30	160	38.5	17
The Warren ... ..	...	168	41	15
Mt. Barker ... ..	...	105	29.5	31
Pallinup ... ..	...	74	14.5	...
Albany ... ..	...	170	36	42
<i>Eastern Division—</i>				
Lawlers ... ..	...	40	8	22
Kalgoorlie ... ..	...	40	9.7	23
Boorabbin ... ..	...	60	7.5	...
<i>Eucla Division—</i>				
Esperance ... ..	...	100	25.3	39
Israelite Bay ... ..	...	60	15	34
Balladonia ... ..	...	44	9.7	25
Eyre ... ..	...	65	11.2	15
Eucla ... ..	...	60	10	43



Apart from the rainfall, which is thus seen to be fairly well distributed all over the coastal zone, the country is watered by means of springs, swamps, and brooks. Rivers are few, and, except in the South-West corner of the State, do not run all the year round; but they all form along their course chaplets of pools, which afford a supply of water for stock or for irrigation.

Although the country, on the whole, looks somewhat lacking in fresh running streams, there is underground an immense store of water, which is reached by sinking wells, varying in depth from 5ft. to 100ft. Many of those wells, however, more especially in the inland districts, are often too highly mineralised to be of any use for the purpose of watering plants.

Soaks abound over the country, and almost invariably follow on the process of clearing land of trees prior to cultivating; wherein their presence is made manifest on the surface by the look of the green patches during the dry months, when all vegetation looks brown and languishing around; there water may be obtained by shallow excavation. Indeed, in the Eastern districts, some 100 miles or more from the coast, and until wells and dams are sunk, soaks constitute the chief source of water supply.

In those drier districts, strewn over the surface of the country, occur bold, bare outcrops of cap slab granite, from 10 to 100 feet in height, covering from 10 to 60 or 80 acres. These outcrops rise from sandy and loamy flats. They seem to have been provided by Nature for the conservation of water in that arid region. After even the lightest rainfall they shed water like a house-roof; in very many cases, somewhere at the foot of those denuded rocks, fresh-water soaks occur in natural dams or basins filled with sand, which, when cleaned, supply for stock or for trees a valuable supply of fresh water.

Nowhere in the South-West Division of Western Australia need fruit growing be checked by dearth of water, as, apart from natural sources of supply, any amount commensurate with the requirements of the orchardist can, at a reasonable cost and with little trouble, be impounded in tanks and dams excavated by means of a plough and an earth scoop.

But, apart from the source of visible water, attempts made of late years to obtain fresh water by artesian boring have proved eminently successful. The first bore put down was in 1894, at Midland Junction, when, by means of a hand plant, an abundant supply was struck at a depth of 500ft., and the bore now discharges through a 4in. lining 260,000 gallons of water per day.

Since then many more bores have been put down along the coastal plateau from the Greenough Plains to the Preston River. Brackish and mineralised water has been struck in several instances, but, as a rule, pure, fresh artesian water, suitable for all domestic

purposes and for irrigation, is struck at depths varying from 230 to 1,000 feet. Around Guildford alone, four or five bores have been successfully sunk, the details of which are thus given in the Western Australian Year Book, published by the Registrar General:—

“The *Woodbridge Estate* bore, completed in 1896, depth 236ft., cost £418; discharges at the surface 150,000 gallons per day. The *Bebo Moro* bore, 1896, put down to a depth of 308ft., cost £265; yield, 86,000 gallons per day. The *Waterhall Estate* bore cost £474, depth 691ft., with a daily supply of 194,000 gallons. The *Lock-eridge* bore, at a depth of 798ft., daily supply 123,000. *Guild-ford Municipal* bore, 1,202ft., supply 1,000,000 gallons per diem. These figures are given to show that almost anywhere on the plains stretching between the hills and the sea artesian water can be struck at a moderate cost, wherein the height of the surface of the ground does not exceed 30ft. to 40ft. above the sea-level.”

In many cases, however, especially in those districts with a scanty rainfall, more highly mineralised soil and indifferent drainage facilities, the advisableness of using artesian water or any water at all for the purpose of irrigation is one which should receive careful consideration, as it is well known that under such conditions irrigation almost invariably raises the salt line to an extent which may prove injurious to fruit-trees.

#### SELECT VARIETIES OF FRUIT ACCORDING TO CLIMATE.

In broad lines, the temperature and the rainfall of various regions of the State have been rapidly mapped out. In both respects they are shown to be favourable to the successful cultivation of fruit-trees, from tropical as well as from temperate climates. The physical or the chemical characteristics of soils can be altered, but the main features of climates are always the same, and cannot be disregarded in the selection of crops. Thus, soil supplying the requirements of the grape vine may be met within Scotland, as well as in the most renowned districts of the south of Europe; yet malt liquors and whisky contribute to the wealth of the Scotch farmers, and brandy and wines that of the vine-growers of the sunny south.

But apart from the influence of latitude, altitude and aspect also tend to modify climate. Snow is met with under the equator on mountains of high altitude. According to the explorer Humbolt, the thermometer falls one degree for every 340ft. of elevation; and under the influence of this law the climate is cooler, and consequently fruits ripen later on the hills than they do in the low land. An instance of this is afforded along the trunk railway line running from the sea over the hills to the eastward. There we see that under the influence of otherwise similar climatic conditions the maturation of fruit crops and grapes is retarded by two or three

weeks on the Darling Ranges, at Mundaring or Chidlow's Well, at an altitude of about 1,000ft. above the valley of the Swan.

If we proceed another 100 miles eastward, we notice that this period of maturation of fruit is entirely reversed under the influence of intervening causes.

At Tammin and Kellerberrin, for instance, with an altitude of 200ft. only less than at Mundaring or Chidlow's Well, and some 750ft. above the Swan, grapes and fruits come to maturity a week or two earlier than they do on the coast. There the retarding influence of altitude is counterbalanced by the more active light, the lesser degree of air humidity, and probably by the greater degree of heat absorbed by the soil.

Due consideration to local climatic conditions should, therefore, influence fruit-growers in the selection of what to plant, with the idea of avoiding a glutted market. Thus the settlers at a greater altitude within the influence of the coastal climate should cater for the later market, whereas those located further inland in the brighter but drier regions will, with earlier varieties, have a good hold of the early market. But here, again, other points have to be considered, and good carrying capabilities must not entirely be overlooked when seeking for earliness in ripening.

*Aspect* will also modify the climate to some extent. Many tender plants will thrive in sheltered spots which would succumb to exposure to the rigours of the climate only a short distance away. Low lying damp hollows subject to late ground frosts often prove fatal to potatoes or to those vines which break into leaf early in the season, although these would have been quite safe on a warmer slope only a stone's throw distant. Then again an eastern aspect, other things being equal, will generally hasten the ripening of fruit by several days. Clay bands or ridges of rocks running across a field will, by throwing up the water, often modify the climatic conditions either for good or evil within a row or two.

Exposure to winds, the colour and the texture of the soil, or in other words, its power of absorbing and of retaining heat and moisture are all factors which to some extent modify a local climate.

### OUR SOILS.

Great stress has been laid on the merits of the climate of the several districts of Western Australia capable of producing fruit, but, before pronouncing on the suitability of any given area, either for agricultural purposes, or more especially fruit growing—a branch of agriculture which is being more particularly discussed in these pages—the fact that the soil is in some measure suitable for the purpose one has in view, must be ascertained.

In the pursuit of fruit-growing, soil must give precedence to climate in as much as the first can, by means of judicious manuring

and cultivation, be made to lend itself to the special requirements of the plant, whereas in the second instance, the welfare and productiveness of the plant is mainly dependent upon the nature and peculiarity of the climate.

It is a well-known fact that soils are more or less suited to different sorts of trees, and it is one of the leading features of Western Australia that the nature and character of the soil is extremely variable; the line of demarcation of one kind being in many instances somewhat abrupt and sharp in its delimitation. On closer examination, however, the soils which are met with in the agricultural districts of this State belong to only a few well-defined types. These are often intermixed together in various ways, and cover, generally speaking, small areas only. Their recurrence at frequent intervals, according to the contour of the locality, lends to the country a motley appearance; a characteristic which has been appropriately expressed by the word "patchy," which applies more or less to the whole of the territory comprised in the South-West of Western Australia. Most conspicuous amongst the soils of that division are the following:—

#### IRONSTONE GRAVEL.

With which the Darling Ranges are mostly covered. The soil consists of ferruginous claystones, or laterite ironstone, showing as coarse pea gravel, varying in size from that of shot to that of marbles. In colour it varies from a light yellow to a dark red, according to the amount of oxide of iron it contains. It is generally mixed with a fertile loam, the result of its own disintegration, or it consolidates into a hard conglomerate which, broken up, makes a very good top dressing for roads.

Where mixed with a fair proportion of loam, this soil is capable of producing a high-class wine, clean to the taste, rich in colour, and of pleasant bouquet. Fruit trees generally do well on it. Generally speaking, it is costly to clear and, on account of the unevenness of the surface, cultivation in many places is rendered difficult.

This ironstone gravel is generally well drained and easily penetrated by plant roots. It is poor in lime and also requires liberal applications of phosphates and of potash. Good results have been obtained by using explosives to crack the subsoil where it is intended to set trees, or by blasting the ground in the winter in proximity of trees already planted. By this means the pipe-clay or the rocks which constitute the subsoil are fissured and a deeper range is provided for the roots.

In gullies and in favoured spots a rich deposit of brown and red loam, varying in depth from 6 to 24 inches, cover this soil, and wherever land of that description occurs, fruit trees or vines bear well and thrive.

The predominant bush plants or standing forest trees generally give an indication of the nature of the soil and of the subsoil. The gravelly ironstone is generally known as "jarrah" country (*Eucalyptus marginata*, Smith). Where there is a certain depth of brown loam on the surface, the jarrah is associated with the native grass-tree or "blackboy" (*Xanthorrhoea*), of which there exists two distinct varieties. Pockets of deep loam amongst the ironstone gravel are indicated by the presence of the red gum tree called "marri" by the natives (*E. calophylla*, R. Brown), which is widely distributed on the coastal and hill portion of the South-West.

The blossoming time of this gum is of particular interest to the fruit grower or the vintner. An early and abundant blossoming—February and March—means little damage to grapes, figs, apricots, cherries, etc., by the birds generally known as "honey suckers." When the blossoming, on the other hand, does not coincide with the time of ripening of some of the varieties of fruit named, the damage resulting from the bird pest is more or less apparent.

Where jarrah, red gum, and blackboys grow together and attain large proportions, the soil is deeper, well-drained, fertile, and suitable in every way for the purpose of fruit and vine-growing. The "blackbutt" (*E. patens*, Bentham) is at intervals met with amongst these trees on the better class of soil. This tree is very hard to burn or to split. A few shots of gelignite in the trunk are of great assistance when burning. The occurrence of pipe-clay, either on the surface or at a shallow depth, is revealed by the presence of White gum tree or Wandoo (*E. redunca*, Schauer). White gum alone is an indication of a cold, retentive porridge made up of pipe-clay and gritty sand, soft and slushy in the winter months and hard in the dry summer season. Small blackboys growing amongst white gums are an evidence of the presence of this stratum of loam on the surface, and, similarly, jarrah and white gum are indicative of a mixture of ironstone gravel and pipe-clay. Lime and phosphates, associated with drainage, are necessary for the raising of good crops on such soil.

Over the same area frequent outbursts of trap rock and volcanic dykes run through the country or occur in patches, and are easily recognised by the occurrence of boulders of blue metal embedded in a rich red loam of volcanic origin. Where such dykes occur, or appear as if churned up with the ironstone gravel, trees and all sorts of crops grow well, and oranges thrive splendidly, particularly when watered in the summer time.

In the gullies alongside the brooks and around the springs, as well as on low alluvial soil bordering water-courses, the Flooded gums, often associated with blackboys, mark out fertile strips of land, richer in potash, but which after a few years cropping require

the application of phosphates. In the south-west the Yate tree (*E. cornuta*, *La Billardière*) grows on such land.

Fresh water can be obtained almost anywhere on this formation at a depth of 12-35ft. on reaching the pipe-clay bottom, whilst springs often break out on their own accord after ring-barking the forest trees or clearing the land for cultivation.

#### CHOCOLATE SOIL.

Known locally as the "jam" land along the Avon valley and Great Southern Railway, or "wattle" country on the Irwin-Chapman and other northern areas. This kind of soil is very widely distributed, and extends from the Murchison and the Irwin over the Victoria Plains, up the Avon Valley to Wagin and Katanning. It is overgrown at the north by the "wattle," and southwards by the "raspberry jam tree," a kind of Myall (*Acacia acuminata*, Bentham). On the whole, this belt of country is drier than the preceding one, but much easier to clear and to cultivate, and eminently suitable for the cultivation of fruit-trees and vines, as well as of cereal crops and mixed farming.

The soil consists of a chocolate loam, sometimes of great depth, varying in texture from a heavy loam, where in its natural state the "York gum" tree (*E. loxophleba*, Bentham) predominates over the wattle or the jam tree. Such land makes splendid corn land, and is more generally found on the slopes of the undulating country which constitutes its home. On the flats the soil is often of a lighter character, and there the wattle or the jam bushes predominate. On the river banks and in patches over the country, a lighter loam still is found and is generally overgrown by the above-named trees, in company with the banksias, of which there exists several varieties, and at times with the "sheaoaks" (*Casuarinas*) and the broom bush or "stinkwood" (*Jacksonia cupulifera*), which generally indicates a moist soil. Cattle and horses, as well as sheep and goats, like the foliage of this pasture bush.

Considered on the whole, the chocolate loam or wattle and jam or York gum land is one of the best balanced in the elements of plant food in the South-West districts of the State, and were it not for, in some seasons, a scanty rainfall, would carry enormous crops of grain, hay, or fruit. Fields not long cleared and cultivated yield, in average seasons 16-26 bushels of wheat to the acre, and 30-40 cwts. of hay. Richer patches of land occur in this country, where the "manna gum" tree grows (*Acacia microbotrya*), noted for the gum it yields. Those patches are generally of volcanic origin and of great fertility; blackboys of very large size also grow on such soil. At places over that country salt patches are not uncommon, and generally follow up the clearing of the land. Their occurrence is

more noticeable in what would have been the most fertile land in the field, in hollows, or at the base of sloping ground, where these salts accumulate.

#### SALT PATCHES

Two sorts of *salt patches* occur in the drier regions of the State: the "white" patches caused by formation of crust or efflorescences on the surface of the soil of salts, which present the appearance of hoar frost on the ground. These salts mostly consist of common salt (chloride of sodium), with chlorides and sulphates of calcium and magnesium. Unless present in large quantities, these salts are comparatively harmless.

The second, the "black" salt patches, are more injurious to vegetation, and in addition to common salt contain Glauber's salt (sulphate of soda), and with it a varying amount of a substance most destructive to vegetable tissues, viz., carbonate of soda or sal. soda. The presence of this salt is always indicated by the colour of the soil in the black salt patches. The latter salt has, on the tissues of plants, a corrosive action; it dissolves the humus contained in the soil, and thus gives it the characteristic black colour often noticeable in such patches. The presence of this chemical salt in the soils is, even in small quantities, detrimental to the growth of roots of the plant, whereas the salts found in the white patches are only injurious when their accumulation becomes excessive, especially at the surface.

The reclamation of salt patches for the purpose of bringing them under cultivation rests upon three chief points:—

1. Draining to carry away the excess salt and preventing fresh amounts being drawn up from the subsoil below. This is the one efficacious and radical way of reclaiming salt patches of any sort. The underdrainage in deep hollows is not only often impracticable but is generally costly. Besides, there is often found, in conjunction with these noxious salts, other chemicals of high fertilising value, such as sulphates, nitrates, phosphates of potash and soda, which would run away to waste in the drains and be lost to the soil. Should this be the case, it would in many instances be advisable to alter the poisonous substances in the soil and neutralise their injurious effect, so as to place them beyond the means of causing any injury, and this can be effected by—
2. Neutralising the corrosive salts by means of chemicals and changing their nature into that of the more innocuous ones. To best effect this, some cheap substance, which by chemi-

cally reacting on the sodium carbonate would transform it into an inactive salt, is necessary, and is readily found in gypsum or sulphate of lime, which by a mutual shuffling or interchange of the basic and acidic elements, become respectively carbonate of lime or limestone and sulphate of soda or Glauber's salt. The gypsum, moreover, renders insoluble the humus taken up and dissolved by the carbonate of soda, and thus retains it in the soil.

3. The injurious substances having been neutralised, it is essential to reduce the surface evaporation which would tend to accumulate on the surface layers the soluble salts sucked up by means of capillary attraction. This is best effected by means of deep cultivation, frequently repeated, and by growing crops which root deeply and cover the ground, and also salt-loving plants such as plants of the cabbage and of the beet tribe or such plants as asparagus, saltbushes, and a variety of others. By such means the successful and profitable cultivation of the soil would, in mild cases, become feasible.

Besides neutralising the injurious effects of the carbonate of soda, gypsum has a correcting effect on the physical conditions of the soil, which often becomes glutinous and forms a clayey hardpan. It coagulates the glutinous substance formed by the carbonate and destroys the puddled condition of the clay, thus enabling the roots to penetrate and the waters to drain through such soils.

#### LIMITS OF SALT IN WATER.

Where irrigation is contemplated it is advisable to have it chemically tested, if the water available is from under the surface or from pools or lagoons and is brackish to the taste.

It is generally considered that the maximum of salt which arable soil should contain is equivalent to .03 chlorine.

As regards water, the amount of chloride of sodium in potable water for continuous use should not exceed:—

For human consumption, 50-60 grains per gallon, or  $\frac{1}{8}$ oz.

For irrigation, 100 grains per gallon, or  $\frac{1}{4}$ oz.

For horses and cattle, 480 grains per gallon, or 1oz.

For sheep, 600 grains per gallon, or  $1\frac{1}{2}$ oz.

These figures, which are suggested by Mr. E. A. Mann, State Analyst, can, however, as he explains, be stretched within certain limits, thus: for irrigation a more highly mineralised water can be used provided it be applied only occasionally and to the roots, so as not to burn the foliage during the hot, or summer weather. Stock also, on sappy food, can stand more salt in the water.



## FOREST ALLUVIUM LAND.

Throughout the interior, from the Irwin towards the Eastern Goldfields railway line, and far beyond, stretches of country occur which are now mostly under tall Salmon Gum trees (*E. salmonophloia*, F. von Müller). These stretches of country were formed by running water wearing away the old rocks and carrying the finer soil down in their course and depositing it on the lower level. They show as large clayey and loamy flats, often many miles wide, of land of fine agricultural value.

With the salmon gum is associated the Gimlet wood or fluted gum trees (*E. salubris*, F. von Müller). Both these Eucalypti yield a large percentage (4 per cent.) of excellent oil on distillation of the leaves, and it would seem that the dropping of the leaves and bark on the surface of the soil has a noxious action on the natural herbage. Soon after the trees are destroyed, either by ring-barking or sap-ping, the natural grasses grow plentifully, and all this country, which until lately was reputed barren, has since been proved to constitute, when cleared, ploughed up, and brought under cultivation, corn land of great value.

Wherever on these forest lands a few Morrell gum trees occur (*E. longirostris*), there the soil is richer still, and the ears of corn crops fill well and weigh heavy, as is the case when the land has been liberally dressed with phosphatic fertilisers. These soils would be benefited by green manuring or by feeding sheep on turnips in the field, to add to the store of humus. This formation rests on marl or limestone. All these trees burn readily, and on this account the cost of clearing is much reduced. As these lands occur in a somewhat arid zone of country, their true value has for a long time been overlooked. By means of water conservation in clay tanks, and after ring-barking, the look of that country soon improves, a good growth of grasses and trefoil spring up, which turn the drought-stricken-looking forest land into nourishing pastures.

## SANDY SOILS.

Scattered more or less over the several formations above described, and especially in the intervening lower belt between the foot of the ranges and the sea, are patches of soil varying from a coloured sandy loam to a pure white sand. That country, which is apparently the result of a considerable subsidence of the coastal front, supports shrubs of different sorts, banksias, she oak (*Casuarina*), bastard jarrah, and in places, where a clay or a gravelly subsoil is met, either white or red gums, with at times blackboys, and also near the coast the Willow Myrtle or Peppermint tree (*Agonis flexuosa*, de Candolle), and on the limestone coast hills eastward of the Darling Range the toart (*E. gomphocephala*, de Candolle). This land is of limited agricultural value, but in many places the soil assumes a darker colour, varying from orange to

dark grey, and wherever limestone or a loamy subsoil underlays the sand at a small depth, and where the ground is moist, there vines and stone-fruit trees grow well when liberally manured.

#### SWAMPS.

Many swamps occur through these sandy patches where rushes, the "Paper bark" (*Melaleuca leucadendron*, Linné), and ti-trees abound. These swamps can generally be drained, and when thus reclaimed can be turned into market gardens of great fertility. In many instances, especially along the coast, the soil is made of an accumulation of silt, mud, and vegetable detritus, which settling in the water collected in basins bottomed by *calcareous* hardpans, form a rich black mould.

These hardpans consist of a conglomerate of greyish mud in which are thickly embedded fragments of sea-shells, and which after being subjected to the process of weathering, crumble down readily and assume the normal condition of a soil rich in lime, phosphates, potash, and organic matter. They prevent the penetration into the deeper soil of roots as well as of water, and their breaking up prior to the cultivation of those marshes is necessary wherever they occur close up to the surface. The pick or the crowbar readily breaks them up into lumps or slabs, but should they be found at a greater depth, one of the readiest and at the same time cheapest ways of breaking them up is by blasting with explosives, which so shatter and crack the hardpan that not only can roots penetrate through the clefts, but the stagnant water also sinks by gravitation, and the land is generally drained to such an extent that it gradually softens and crumbles down until ultimately the hardpan completely disappears. Where fruit-trees have already been planted without breaking up this hardpan they sooner or later, whenever their roots reach the retentive hardpan, languish and flag; in such cases one or two cartridges of dynamite exploded on each side of the tree in the winter time when it is dormant will, without injuring the tree, remove the obstruction and bring relief.

Fertilisers and manures will be necessary for the production of paying crops in sandy soils, *i.e.*, field peas well manured and ploughed in when in blossom.

Having been intermixed more or less, these several typical soils of the South-West division of Western Australia give rise to a greater variety of soils, some of which, like those of a sedimentary nature, occur along the course of existing or old river beds, usually deep, well drained, and fertile.

#### RING-BARKING AND CLEARING LAND.

Mr. L. Lindley-Cowen, late secretary of the then Bureau, now Department of Agriculture, thus summarises in this chapter the practice and the opinion of experienced settlers from various parts of the agricultural districts of this State:—"To new-comers unac-

quainted with the readiest methods of converting bush land into fruitful farms and orchards, much valuable information will be gathered from the teachings of others."

Following are the common and botanical names of the trees referred to in the returns on ring-barking reviewed below:—

Jarrah (*Eucalyptus marginata*, Smith)  
 Red Gum or Marri (*E. calophylla*, R. Brown)  
 Flooded or "Blue" Gum (*E. saligna*, Smith)  
 White Gum or Wandoo (*E. redunca*, Schauer)  
 Spotted Gum or Bastard White Gum (*E. accedens*)  
 Peppermint (*Agonis flexuosa*, de Candolle)  
 Yate (*E. cornuta*, La Billardière)  
 Sheoak (*Casurina Fraseriana*, Miguel)  
 Paper bark (*Melaleuca* sp.)  
 York Gum (*E. lorophleba*, Bentham)  
 Jam (*Acacia acuminata*, Bentham)  
 Manna Gum (*E. viminalis*, La Billardière)  
 Salmon Gum (*E. salmonophloia*, F. von Müller)  
 Morrell, or Parker's Gum, or Mallee of Victoria (*E. oleosa*,  
 F. von Müller)  
 Fluted Gum, or Gimlet Wood (*E. salubris*, F. von Müller)  
 Mallet (*E. occidentalis*)  
 Blackboy (*Xanthorrhoea*)  
 Wattle (*Acacia leiophylla*, Bentham)  
 „ Badjong (*A. microbotrya*, Bentham)  
 Karri (*E. diversicolor*, F. von Müller)  
 Spearwood (*E. Doratoxylon*, F. von Müller)  
 Tooart (*E. gomphocephala*, de Candolle)  
 Blackbutt (*E. patens*, Bentham)  
 Zamia (*Cycas* Sp.)

The object of ring-barking or of sap-ringing is to kill the trees, in order that the pasture and water supply may be improved, and to facilitate clearing in the future.

Trees are destroyed by ring-barking when a belt of bark

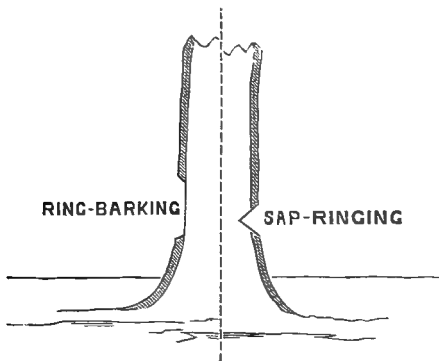

about a foot in width is taken off the stem, whilst sap-ringing consists in cutting into the sap or outer wood of the tree as well as taking off the bark. The illustration herewith shows the different methods, and on perusal of the following pages it will be found which varieties of trees, in the opinion of old colonists in various dis-

tricts, should be ring-barked and which sap-ringed.

When setting about ring-barking and clearing, a few trees should be left standing. Shade is quite as grateful in the hot summer months to stock as feed.

## SOUTH-WESTERN DISTRICT.

*Varieties of Trees.*—Jarrah, red gum, flooded gum, banksia, white gum, blue gum, peppermint, yate, blackbutt.

*Method and Time of Destruction.*—Great diversity of opinion exists apparently, both as to the method of killing the trees, whether by ring-barking or sap-ringing, and also as to the period of the year during which the work should be done. There is, however, a unanimous opinion that jarrah, red gum, banksia, and blackbutt should be destroyed by ring-barking, and yate, peppermint, and flooded gum by sap-ringing. In the case of blue gums the advocates of sapping and ring-barking are equally divided, while in the case of white gums the advocates of ring-barking are in a large majority. Our correspondent does not enumerate the trees in his locality (Bridgetown), but advises "all to sap when the trees are in flower"; while another correspondent would "advise all new-comers to adopt ring-barking."

In regard to the time of the year when the ring-barking or sapping should be done, there is a wide range of opinion. All the months in the year are recommended, except April, May, and June. There is a slight preponderance of opinion in favour of ring-barking the trees from October to February. One correspondent at Jayes reports having killed jarrah and white gum in three days by ring-barking in February. July to October appears to be the best period for destroying the red gum; January, February, and March for the blue gum, white gum, flooded gum, peppermint, yate, and black-but. All, with one exception, agree that the banksia may be killed by ring-barking at any period of the year, the dissentient being in favour of the months of January, February, and March.

Yate requires ringing in January, as if rung at that time it will die in a few days, and will not throw up suckers, which it will do if rung in winter months. . . . White gum you can ring at any time when the bark strips freely; in fact, it is no use ringing any tree if it will not bark freely.

*Blackboys.*—The grazing capacity of land is much increased by cutting down blackboys or grass trees or chopping off their head. Stock much prefer cleared land and grass, trefoil and herbage soon become noticeable. Where the cost of handling and railing blackboys permit of their trucking to some distance, it is found that a ready market now exists for them. The Rowley Forest Laboratory at Maylands is capable of handling large quantities of these at their works, which is concerned with the extraction from Blackboy and *Zamia* of sago, tar, colouring dyes, perfume, etc.

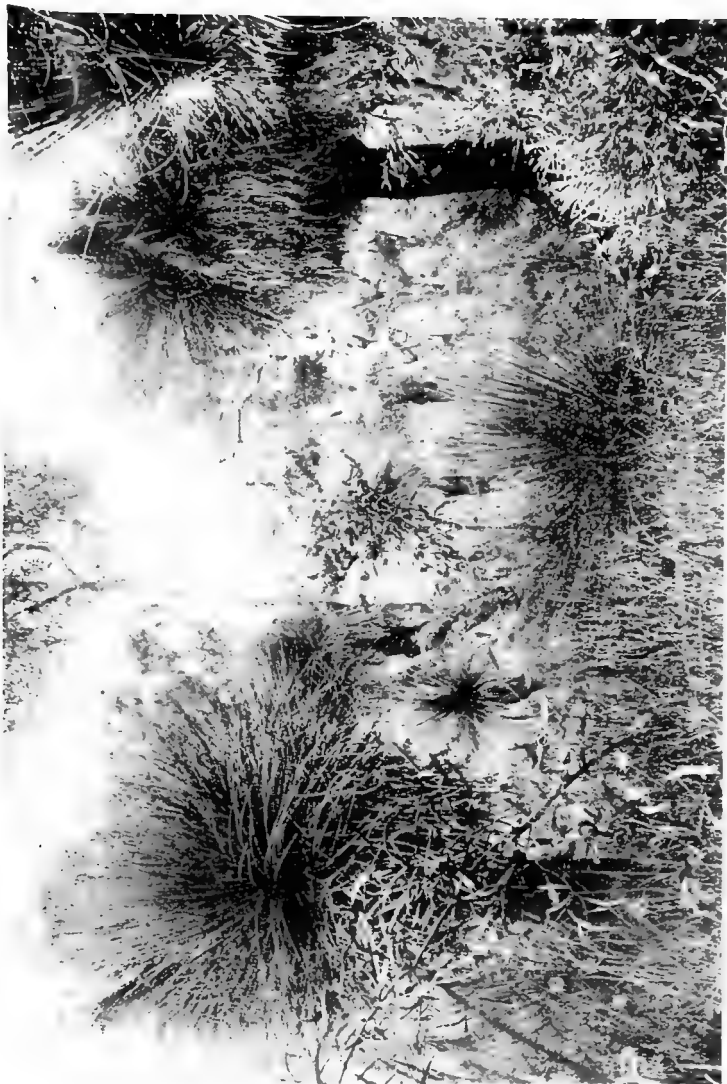

Blackboys or Grass Tree (*Xanthorrhoea*).



## MURRAY DISTRICT.

*Varieties of Timber.*—Jarrah, red gum, blue gum, banksia, shea-oak, paper bark, wild pear tree.

*Method and time of destruction.*—Jarrah, ring-barking. Red gum, Mr. Richardson recommends ring-barking, while the Murray Horticultural Society recommends sapping. Blue gum, shea-oak, paper bark, wild pear, sapping; banksia, ring-barking.

August to December for all trees except banksia, which may be rung at any time, and paper bark and wild pear, the best period for ringing these being returned as doubtful. "The blue gum can be killed at any time of the year within 24 hours if it is properly sapped," according to the Murray Horticultural Society's return. The honorary secretary of this society, in returning the form, writes:—"It is the general opinion here that ring-barking and sapping tends to toughen the roots of the trees, making the trees harder to pull up for some time after, so if you cannot afford to wait for two or three years to allow the roots to rot it is a better plan to pull up the trees green, as the heavy tops help to bring them down. But having waited the time mentioned, the clearing of land is made all the easier, as the trees come down willingly."

## GREAT SOUTHERN RAILWAY DISTRICT.

*Varieties of Trees.*—White gum, York gum, jarrah, jam, shea-oak, stinkwort, manna gum, flooded gum, red gum, yate, salmon gum, Parker's gum or morrell, mallet or fluted gum.

*Method and time of destruction.*—Sapping is recommended for all the trees mentioned above with the exception of the salmon gum, which our correspondent advises should be ring-barked. York gum and flooded gum are liable to throw up suckers, it is said in another return. "Sap ringing is desirable in each case for immediate results, but ring-barking is preferable if one can afford to wait the results for say four years."—*Wagin-Arthur Farmers' Alliance*. The Katanning Farmers' Association advocates destroying the white gum and jarrah either by ring-barking or burning around the butts; and ring-barking jam, shea-oak, and manna gum, and sapping York and flooded gums. Stinkwood if cut down dies out. York gum and jam should be rung when the sap is well up. The bark will then fall off every limb and the roots can be burnt right out. Flooded gum is very difficult to kill. Firing round the trunk in the month of March very often has the desired effect. Two correspondents state their experience has shown that ring-barking and sapping may be carried on all the year round with successful results if the work is properly performed. The *Wagin-Arthur Farmers' Alliance* advises that the work should be done during December, January and February, while the Katanning Farmers' Association advocates ring-barking or sapping, as the case may be, in Septem-

ber and October, for all trees except manna gum; the period for this variety being extended from September to March. Sheaoak may be treated at any time.

#### YORK DISTRICT.

*Varieties of Trees.*—York gum, white gum, salmon gum, jam, blue bush, native cassia, manna gum, morrell gum, flooded gum, sheaoak.

*Method and time of destruction.*—The Beverley branch advises ring-barking all the eucalypti, while the York branch advocates sapping without any reservation. The Greenhills Progress Association advises that old York gum trees should be sap-ringed, and that young ones should be ring-barked; that white gum, salmon gum, cassia, and jam should be sap-ringed, and that the blue bush should be cut down. It will thus be seen there is a preponderance of opinion in favour of sap-ringing.

From January to April is the opinion of the York and Beverley branches for ring-barking or sapping all trees, while the Greenhills Association advises November to April for ring-barking York gum, and May to October for sapping this tree. November to May is the period advised for destroying white gum and cassia, and “any month” for the remaining trees.

Mr. W. Padbury filled in a return embracing his experience in the Eastern Districts, the Victoria Plains, and at Yatheroo. His remarks may be inserted here. He says:—“I would not cut through the sap of trees on land I wanted to cultivate; as when the tree is dead and the tree-puller is put on to it, if it has been cut through the sap, it is liable to break off and leave the stump in the ground. I prefer using the tree-puller in clearing, to the ordinary grubbing, as it pulls more roots clean out, and in ploughing afterwards you do not find so many obstructions. For red gums, white gums, salmon gums, and York gums, I find sapping the best, and the time I do it is as soon as the bark will run after the first winter rains until the sap goes down again. With flooded gums I find you must cut through the sap, as they will not die otherwise. My experience is that trees that have been sap-ringed do not generally throw out so many suckers. Some trees takes two or three years to die, according to the nature of the tree and the land on which it grows. I think when the sap is well up, say September, October, and November, is the best time for ring-barking, as the tree dies more quickly if the work is done at this time.”

*Effect of the destruction of the trees upon the water supply and growth of native grasses.*—There is an unanimous opinion expressed that a most marked increase takes place in both the water supply and the number and vitality of the native grasses that spring up after the trees have been destroyed.





Marri (Red Gum) and Jarrah forest ring barked prior to clearing.



## NORTHAM DISTRICT.

*Varieties of Trees.*—York gum, jam, morrell, white gum, gimlet wood, salmon gum, manna gum, wattles, sheaoks, flooded gum.

*Method and time of destruction.*—Mr. Gregory advises ringing salmon and flooded gums, sheaok, and jam, and sapping white and York gums. This, in the main, is also the advice of the Irishtown branch, while Mr. Throssell advises sapping all the trees except the jam, which should be rung. Mr. Dempster furnishes an interesting note on the destruction of York gum. He writes:—"All trees or scrub can be killed at once by sapping, but the York gum throws out shoots for years after the top of the tree has been killed, and the cost of keeping under the suckers is more than that of ringing in the first instance. I have not yet met anyone who can speak positively as to the best time of the year for ringing these trees. Occasionally some die, and give no further trouble, but as a rule they will not, under the present system. Killing the tree slowly by barking, I think, is the most effectual. I have an idea, supported by facts, that goes to prove that by killing the tree slowly the strength returns to the soil, for the best results I have ever seen from ringing have been by the slow process."

## TOODYAY DISTRICT.

*Varieties of Trees.*—White gum, jam, York gum, red gum.

*Method and time of destruction.*—White gum, ring-barking; York gum, ring-barking or sapping; jam, sapping; red gum, not stated.

White gum should be destroyed from September to October; York gum, February to March; jam, at any time; red gum, not stated. The secretary adds in a note: "The branch is of the opinion that the red gum should never be interfered with on the pastoral lands, as these trees do not do any harm to the feed and are invaluable as shade."

*Cost per acre of clearing before and after the destruction of the timber.*—Before, £3; after, £2 10s. to £2 15s. The secretary writes as follows:—"For agricultural purposes, the branch is of the opinion that grubbing when the timber is green is preferable to killing the timber by ring-barking or sapping before clearing. The cost per acre of clearing after ring-barking is from 5s. to 10s. less, but this is from two to three years after the ring-barking has been done."

## GERALDTON DISTRICT.

*Varieties of Trees.*—Wattles, York gum, jam, flooded gum.

*Method and time of destruction.*—Wattles, York gum, and jam, by ring-barking; flooded gum by sapping.

November or December, when the sap is down, is returned as the best time for destroying the trees.

*Effect of the destruction of trees upon the water supply and growth of native grasses.*—The effect is very great upon the water supply. Even within six months after ringing, the supply gets stronger; the grass grows thicker and is appreciated more by stock.

Mr. McKenzie Grant, Newmarracarra, writes:—"Ring-barking I find is only the beginning of clearing the land, as the saplings and young shoots keep springing up, and have to be grubbed out year after year."

*Cost per acre of ring-barking, sapping, and clearing.*—The clearing of the land ready for the plough, either for farming or for fruit growing, is much reduced after the timber has been killed by ring-barking or sapping. A better burn is secured, the toil of grubbing out the trees is lessened, and when felled the dead roots displace and bring up to the surface a smaller quantity of the raw subsoil.

"Ring-barking" consists in cutting around the stem and through the bark to the growing wood a double ring eight or nine inches apart and with the back of the axe knocking out the strip ring between. This will interfere with the downward flow of the sap and the trees first linger and then die.

"Sap ringing" consists in driving the axe through the bark and the cambium or growing wood in two rings likewise a few inches apart. This operation causes the trees to die quicker, but sometimes results in suckers growing round the butt.

"Frill ringing" is done by driving the axe through bark and cambium round the stem, pressing outward at the same time. This done, a solution of arsenic is poured into the fresh wound with the view of poisoning both ascending and descending sap, and leads to the speedy killing of the tree and the prevention of suckering.

The average cost per acre of frill-ringing, sapping, and ring-barking is 1s., 2s., and 3s. respectively, and this small expenditure reduces the cost of clearing, after the timber has been cleared, fully one-half.

As regards clearing proper, the cost ranges from £1 5s. per acre, when the trees are simply removed by the method known as "Mullenising" or burning on the spot, without grubbing out the roots, to £25 and £30 per acre, as in the case of mixed Karri and Red gum scrub in the south-west portion of the State. The cost in each case is governed by the character and density of the trees and the skill of the bushman, and no estimate of the cost can be given. The use of explosives, traction engines, and of tree pullers, by reducing the cost, has made it possible to clear trees, roots, tops, and all at prices which under the old method of hand grubbing was absolutely out of reason.

*Tree clearing and water supply and growth of native grasses.*—There is a decided consensus of opinion that the destruction of tim-

ber improves both the water supply and the growth of the native grasses.

Especially is this noticeable on the Salmon gum country, which prior to killing the timber is devoid of herbage. The effect is striking, as different species of grasses put in an appearance the first winter after the timber has been ring-barked and grow luxuriantly. Since this fact has been demonstrated the salmon gum forest land has come into great favour.

The effect is also very great upon the water supply. Even within a few months after ringing, the supply of subsurface water gets stronger.

Jam acacia in the Avon Valley and along the Great Southern Railway seems to be the only tree around which grass grows and keeps green to any extent, and on that account, and because of the value of the wood for fencing posts, it is generally allowed to grow on farms in the making.

#### CLEARING : HOW TO DO IT, AND HOW NOT TO DO IT.

The removal of timber from virgin land preparatory to ploughing, is known in Australia as "grubbing and clearing." The cost of doing this work, of course, varies very greatly, as will have been gathered from the earlier chapters. The chief factor in the cost of clearing is the quantity of timber that has to be removed, and there are also subsidiary causes which regulate the price at which the work can be done, as, for instance, the nature of the soil, the time of the year at which the work is carried on, the variety of timber, the proximity to the labour market, and the mechanical aids that may be employed. Taking all these things into consideration, and speaking generally, the spring and early summer are the best periods of the year in which to do this work. If the land is clay, or at all inclined to be stiff, it will have been well soaked by the winter rains, and be easier to remove from around the roots of the trees. Land cleared in the spring and ploughed the same season is less prone to throw up suckers from the fragments of roots that are bound to be left on the ground, no matter how carefully the work is done, than land cleared or ploughed in the autumn or winter. Another advantage of clearing in spring and early summer is that the rains are less frequent and the timber has a better chance of burning. Light sandy soil covered with banksia and other woods that burn readily, may be cleared at any time of the year. The new settler may think that anyone who has sufficient strength can do grubbing and clearing as well as the next one. This is a great mistake. One cannot exalt clearing into an art or a science, but there is a knack in doing the work that, simple as it looks, requires a good deal of

practice before one can become master of it. So much is this the case that if the inexperienced settler has the money at his command, it is wise for him to get this most laborious work done by contract.

If he has not, and is compelled to do the work himself, the hints conveyed in the following notes may be of use to him. If I now give, in skeleton form, the outline of a specification for clearing, it will, I think, with a little explanation, convey to the mind of the new settler the chief features of the work that has to be done, and the proper way in which it should be performed:—

1. All trees to be grubbed completely round and out to a depth of not less than 18 inches, and all roots to be run to the same depth, or until they can be broken by the hand.
2. All underground blackboys to be grubbed out below the crown.
3. All zamia palms to be grubbed and completely removed from the ground.
4. All scrub large enough to impede the progress of the plough, or that cannot be completely turned in in ploughing, to be grubbed out.
5. The timber and scrub, after having been grubbed, to be burnt, and the ashes spread as far as they can be cast.
6. All wood not absolutely required for burning the butts and stumps of trees, to be left on the ground.
7. No holes to be filled in until they have been examined by or his agent; when passed, to be filled in three inches above the level of the surrounding ground.
8. The whole of the ground to be left ready for the plough, and the contract to be completed in a workmanlike manner on or before .
9. If the contract is not completed on or before the date abovementioned a penalty of shillings per day for every day over the specified time, to be paid by the contractors, and deducted from any money that may be due to them.

Such is the rough framework of a specification for a grubbing and clearing contract. The first clause is self-explanatory. The second and third clauses refer only to that part of the country where zamia palms and underground blackboys are to be found. The latter, if not grubbed well below the crown, that is, where the leaves shot from the bole will continue to spring up perennially.

Clauses 4 and 5 need no explanation, unless it is to say that the reason for having the ashes spread is that they are a valuable potash manure, and should be made as much use of, and

spread over as large a surface of ground as possible. Clause 6 is inserted at discretion. If work is very plentiful, and the settler has a large area, it may be omitted; but if the area is 100 acres or less, the economy of firewood cannot begin too soon. It may appear to the settler that there is plenty of wood for all the world, and for ever; but even if there was, there is no sense in wasting it. There is no sense in wasting anything, so far as my experience goes. But, as a matter of fact, it does not take very long, if clearing is vigorously pursued, to exhaust the wood supplies on a 100-acre farm; for it must be borne in mind that, even with the most careful management, about 80 per cent. of what would otherwise be available for firewood has to be used in burning the trunks and butts of trees that cannot be utilised.

It is important that no holes should be filled until they have been examined for roots, and when they are filled in they should be heaped up a little, in order to allow for the settling down of the loose soil that must eventually take place. It is for the person letting the contract to say whether he will supply tree pullers, tools, explosives, and rations. As a rule, the contractors supply themselves with all these things, and it is better, as it saves possible complications, that they should.

Before going any further, I should like to impress upon the minds of not only new settlers, but old settlers also, the desirableness of having all contracts made in writing. Memory is so apt to play us false; black and white, never. The risks to both sides of acting upon a verbal agreement are infinitely greater than committing oneself to any serious error in signing a written contract that has been mutually agreed upon.

To return to clearing, and the new and inexperienced settler who has, perforce, to undertake the work himself.

On clearing the lighter soils, which generally, in this State, mean lighter and easily removed timber, there is very little to be said. Common sense in this, as in everything else, must be the settler's best guide. It may be that it will be considered desirable, the first year, to leave all the large timber standing, in which case it should be ring-barked at once, no matter what time of the year—and grub out only the small stuff, say 12 inches in diameter and under. If the large trees are not too thick, this can be done with advantage, and the ground can be ploughed—"scruffed up" is the better expression, as it is hardly ploughing, under the circumstances—with a stump-jump plough. This plough, as its name implies, is constructed in such a manner as to permit ground of the very roughest kind being worked. If an obstacle which cannot be cut through is encountered by the share, the movable beam is raised by the tractive force, and, after the obstacle is passed, the

share falls into the land again and recommences work. The stump-jump plough is, however, an expensive item—a double-furrow costing about £17, and a treble-furrow £23—the small settler will

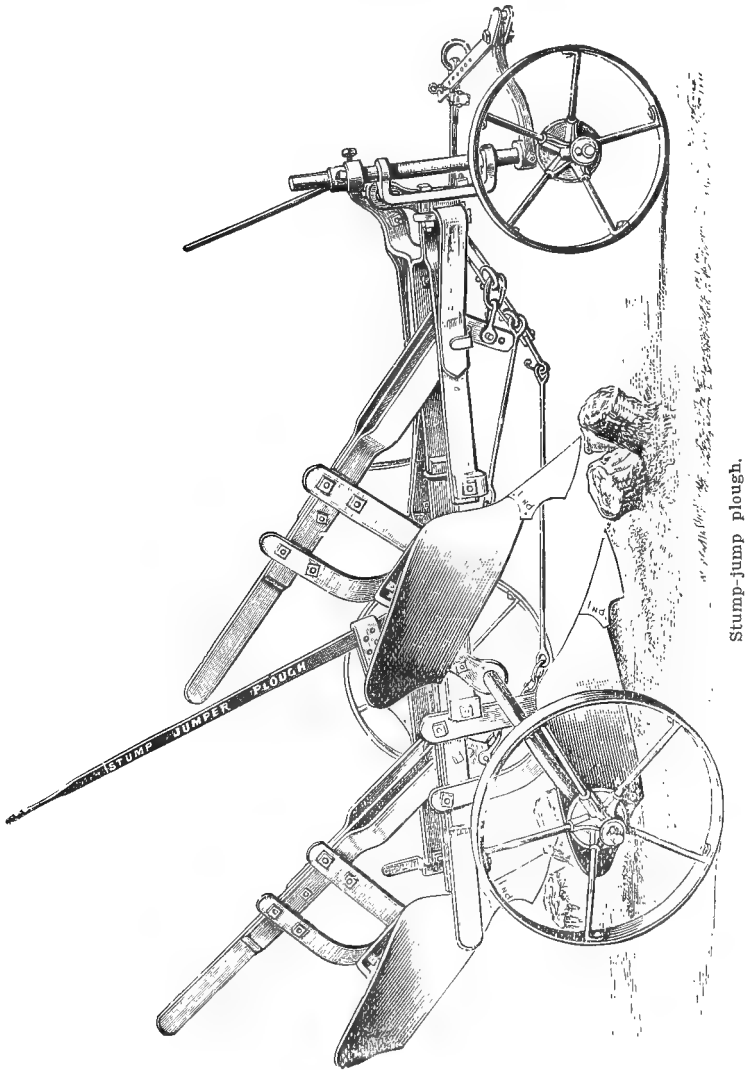

Stump-jump plough.

be hardly able to afford, and unless he can get the work done by contract, an ordinary single-furrow plough will have to be called into requisition. Ploughing only partially cleared land with a single-furrow rigid plough is a most exhilarating, but not alto-



gether satisfactory, operation, but still it can be done with a little care and without damaging the implement. If the land is to be cleared outright at once, which is by far the best way, if time and means permit, the settler must gird up his loins and make up his mind to tackle the job bravely. If a big tree has to be got out,

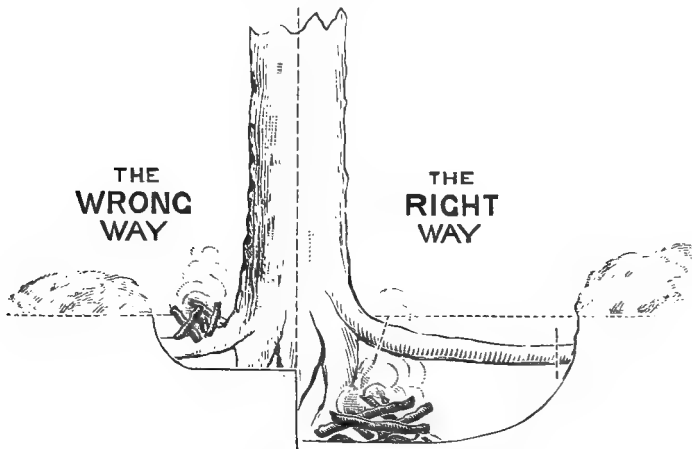

it is no use playing round the roots. Dig the soil away well round the tree, so that you have plenty of room to work. There is nothing gained by chopping off the roots close by the trunk, for you must remember that every root has to be traced until it is well out of the way of the plough that is to follow clearing. Again, the tap root has to be got at, and this cannot be done unless you give yourself ample room to work round and under the tree. If the tree has plenty of top, when the main lateral roots are cut, in all probability it will fall; but if there is little or no top, then either the tap root will have to be cut, or the agency of fire will have to be invoked. Don't be too ready with the fire stick. Grub well round the tree to the full depth before you think of starting the fire. Once you have started your fire, do not think of letting it go out. Clearing is not eight-hours-a-day work. Last thing at night and first thing in the morning the fires have to be gone round and put together. A sapling from six to seven feet long is used as a lever for putting the logs together whilst burning.

A second and more expeditious method of clearing is by means of a tree-puller or "forest-devil." Several of these machines, both for horse and man power, have been invented and perfected in this State, and will be found satisfactory in every way. Where clearing has to be done quickly and on a large scale, the tree-puller is almost indispensable; but on a small piece of land, and especially when it is intended for vines or fruit trees, I am inclined to think

that the slight extra cost of clearing entirely by hand is money saved in the long run.

A third method is by the use of "explosives," and this I have found both expeditious and profitable, especially on ring-barked country where the timber is dead. I have always used dynamite in preference to either powder or rackarock, the only other explosives I have tried. It is not necessary to use sufficient explosive to blow the tree down, but merely to loosen the ground about the roots and create a vent under the butt of the tree. When the timber is dead, a fire-stick will generally do the rest. A hole should be bored with a 1 $\frac{3}{4}$  or a two-inch auger, not in the butt of the tree, but immediately under it, in the fork of the roots. Augers 2ft. 6in. long may have a 15in. piece welded on by a blacksmith so as to make the length 3ft. 9in. From  $\frac{1}{4}$ lb. to  $\frac{1}{2}$ lb. of dynamite, or preferably gelignite, will be quite sufficient to shake up the roots and create a vent for the fire under the largest tree. If the tree be a green red gum (marri) and very sappy, give the bore a slight incline for drainage. Press gently into the hole 3 to 9 plugs of gelignite, according to the size of the tree, and using a smooth wooden thumper and never an iron rod. In the last half-plug, which can be cut without danger, make a hole with the blade of a knife and insert with care a "detonator." Into this fit a piece of fuse a couple of inches longer than the hole, place inside the hole, pressing gently. Fill the hole with earth or sand gently pressed, fire, and retire to a safe distance. The result of the explosion is that the trunk is generally splintered to matchwood, and when dry, about March or April, if exploded before Christmas, will burn readily without stacking large quantities of small wood around the butt. The hole should be bored to pretty well the core unless the tree be pipy, in which case the charge will fizzle out without the necessary concussion to splinter the tree.

Large and unwieldy stumps can be treated similarly. The most arduous part of this method is the boring of the holes which has hitherto been done by hand, but an ingenious boring plant carried from tree to tree on a wheelbarrow has lately been designed by Mr. Gordon Hester of the Blackwood, which does the work mechanically with notable speed and therefore at a greatly reduced cost.

On stiff clay land, where the ground is very hard, a considerable saving in time, and consequently money, is effected as described, to loosen the ground round the trees. Gelignite may be had in 5lb. packets, costing 8s. 9d.; detonators cost 1s. per doz., and fuse 1s. per coil, pre-war prices.

At one time it was thought the royal road to clearing had been found in the use of "saltpetre and kerosene." I have tried the following method myself, but must say have only found it to be advantageous with timbers that will in any case burn readily. A



Red Gum (Marri) before and after blasting.







Government Traction Engine pulling forest trees on Soldiers' Settlement blocks.



Forest trees pulled down by Traction Engine.

hole, eighteen inches deep, is bored with a 1¼ inch auger down the centre of the stump after the tree has been felled. Into this hole two or more ounces of saltpetre are put, or it is filled up with kerosene and plugged up. In fine weather, in the spring, the plug is removed, and about a quarter of a pint of kerosene is put in if the saltpetre has been used, or the hole is again filled up with the oil, if oil has been previously applied. This being set on fire, it is said the stump will continue to burn away quietly until both stump and roots are consumed. Personally, I am of opinion that a little dynamite properly applied, or one of the other methods of clearing mentioned in this chapter, are cheaper and more satisfactory in the end, where the hard burning wood of Western Australia is concerned.

There is a fourth method which is certainly the most expeditious, but it requires a large amount of capital, and would only pay where a large area of country had to be cleared. I refer to the use of "traction engines" fitted with long wire ropes, by means of which the trees can be pulled down as they stand without any preliminary preparation, and then "snigged" up into rows eight or ten chains apart, and there left for all time or to be burnt off at leisure. If this process is followed, there is nothing to do but to fill up the holes and set the stump-jump plough to work.

This method of clearing land in the big timber country of the South-West has been carried out with much success by the Government, a charge per working hour being made to cover the cost of wages, fuel, and depreciation. The chief objections raised are that trees sometimes snap under the strain of the wire rope and the stump has to be extracted. Moreover, when large size green trees are pulled down a great mass of the earth constituting the subsoil remains attached to the roots, leaving cavities in the ground which have to be filled with that cold, raw, tenacious soil.

#### BURNING OFF.

With some varieties of trees it is much easier to get them down than to get rid of them after they are down. This is particularly the case when the timber has not been previously killed by ring-barking. The usual method of getting rid of the timber is by burning it, first cutting the smaller limbs up into convenient lengths for handling with an axe or crosscut saw. The larger limbs and butts of the smaller trees should be also cut up and pulled up to the largest trunks by horse power. The mistake is sometimes made, by those who have not done this work before, of stacking up all the small timber on the trunks and setting fire to the whole lot at once. This should not be done except in the case of trees that are dead and consequently dry, and that are

known to burn freely. The fire should be diverted on one side and kept up as much as possible so as to drive out the sap or the moisture gradually. Burning off is at best, under the most favourable circumstances, a tedious process, and though it may seem very slow work, it is quicker in the long run to economise the smaller stuff and add a little to the fires as needed. It occasionally happens, in spite of the greatest economy, there are still butts unburnt which are too large to be moved whole and which cannot be split by the wedge and maul. When this occurs, it has to be decided whether it is cheaper to haul more timber to the spot or break up the butts by means of explosives.

Another way which has been recommended to me, but which I have not tried, of getting rid of the huge butts of red gums and other trees that are full of sap and refuse to burn except under the most intense heat, is to throw earth up to them and treat them in the same manner as if burning charcoal. In burning off, in fact, in the whole operation of clearing for the plough, it should not be forgotten that it is one hundred per cent. labour, and in order to cheapen the process as much as possible, not cheap labour, which is very often dear labour in the long run, but mechanical appliances and every other available means should be employed to assist the capable labourer in his work. In the rudimentary, but necessary, work of clearing, brains should come into play as well as hands. The foregoing remarks are not intended as a complete discourse on the whole art of clearing, but merely to indicate to the newcomer the several methods which may be followed with advantage. In this, as in everything else, a little practical experience is of more value than a whole library of theory."

#### PREPARATION OF LAND FOR PLANTING.

The locality of the future orchard or vineyard having been selected, and the land cleared on a site best suited for the purpose, a few words on the preparation of the land will be found of use.

In this country where high winds must occasionally be expected within the coastal zone, naturally sheltered sites should as much as possible be sought for. This will apply equally well to inland districts, where the hot scorching North-Easterly winds at times blight the tender foliage of plants. Fruit trees must have shelter. If nature does not offer it, artificial means will have to be resorted to. Deep gullies and damp, drafty hollows are as unsuitable for them as the denuded summit of exposed hills; it often happens that the blossoms will not set in either situation.

Fruit land requires more thorough treatment than soil set apart for general farming cultivation.

In planting a vineyard or an orchard, it should always be borne in mind that the work is being done for a long succession



of years, and that future success depends very much on the way it is first planted. No return will be expected for the heavy outlay it involves for the first two or three seasons, although for a long succession of years to come the grower may expect to be recouped for the money, thought, and care spent in first establishing the plantation. In order to achieve success, the work must be carried out thoroughly and intelligently. Be well impressed with the fact that a 20-acre vineyard or orchard, well planted and carefully tended, will produce a crop nearly as heavy as 40 or 50 acres of trees merely stuck in a soil badly drained, un aerated, and only partially stirred. The vines and trees, moreover, in the properly planted and thoroughly cultivated orchard or vineyard will be more luxuriant, longer-lived, the crop more healthy, more abundant, the produce will be easier to handle, superior in quality, while at the same time the toil, risks, and anxiety of the grower, will be considerably lessened.

The nature of the soil influences appreciably the character of the produce, and, to a certain extent, the different classes of trees.

The grape vine, for instance, although one of the hardiest of the cultivated plants, does not yield the same type of produce in all kinds of soil.

A typical and congenial soil for vines and fruit trees is a friable, easily worked loam, deep in preference, with a healthy subsoil, naturally well drained, to which both air and warmth can penetrate from the outside, and which at the same time is sufficiently retentive of moisture to invigorate the roots of the plant and permit it to resist the severe droughts. Our red gum country typifies that class of soil.

The object the vine-grower has should, to a great degree, influence his selection of soil for planting his vineyard.

For table grapes and raisins it may be stated that the richer the soil the finer will the grapes be, and the more handsome the well-filled bunches, with well-set swollen berries.

The choicer "wines" on the other hand, are produced in soil of a poorer description, especially on light sandy loams and iron-stone gravel. In the case of wine, it often happens that quantity is adverse to quality: on very rich alluvial flats, for instance, the must contains sometimes an excess of albuminous matter, which affects the keeping quality of the wines, while bouquet is lessened, and a peculiar earthy flavour, disagreeable to the palate and the nose, is distinctly perceptible.

A sandy soil generally gives a dry thin wine, and if the season be moist the colour may be poor. The wines, however, produced on these soils are generally straight to the taste—that is to say, can be blended with most other wines, without changing their respective characters.

A heavy clay soil, on the other hand, produces a full-bodied wine, heavy, rich in extract, and in some cases may impart to it a peculiar taste known as an "earthy taste."

Between these two widely different soils, there are other intermediate ones that partake more or less of the character of the one or the other, according to the respective proportion of their sandy or their clayey constituents.

On limestone formations, the wine will be delicate to the taste, with a fine brilliant colour and a pleasant flavour, which in the drier localities may be inclined to be fiery.

Volcanic soils will produce vigorous dry wines.

Besides the geological character of the land, the natural flora which cover it give some indication as to its suitability for wine-growing and fruit-growing.

A slope always assists drainage, but more especially in the drier districts of this State a vineyard always looks more luxuriant, and gives a better yield on the flats and on slightly undulating country, the reason being that during the long, dry and hot summers which sometimes prevail, the slopes often get too dry, and the vine suffers considerably. During the heavy downpours of rain, too, that come down occasionally, a quantity of soil is sometimes washed down the steep slopes, leaving the land denuded and deeply cut by the rush of water down the incline.

In cooler climates, such as the centre of France and the banks of the Rhine, the slopes are generally planted in vines, in order to utilise the full amount of sunshine and warmth; but in this country of light and heat, shelter from the wind is of far greater importance, and should mostly be studied in establishing a vineyard or an orchard.

Generally speaking, in our singularly genial climate and wherever moisture is sufficient, many fruit trees will grow and produce some fruit in almost any soil, except dry, pure sand or wet undrained swamps. The several sorts of fruit trees grown, however, accommodate themselves more readily to the different classes of soils, and in that respect the likings of each kind should be studied and as far as possible satisfied.

As a rule, the *light sandy loam* which is very prevalent, by reason of its warmth and the "available" plant food it contains, is quicker than stronger soils; it is also more easily cultivated, but it soon runs out, and unless the drain on its store of plant food caused by continuous cropping is made good by applications of fertilisers, the vigour of the trees is checked, they are comparatively short-lived, and soon become unproductive. Such trees very often fall a prey to the attack of insect and fungoid pests, unless these are vigorously kept down. Peaches, nectarines, almonds, figs, vines, mulberries, melons, and tomatoes will, with care and liberal manuring produce good crops on such soils.

Deep trenching, wherever the subsoil is of a heavy nature, or top-dressing with clay, swamp or river mud, or farmyard manure will considerably alter and improve the texture of such soils. So also will green manuring or the ploughing in of some green crop, preferably a leguminous crop which is a cheap nitrogen gatherer.

A deep *gravelly loam* constitutes a better orchard soil, and the hardier fruits will do well on it provided the climate suits.

*Strong loams* are about the best all-round orchard soils. The trees grown on them do not, as a rule, bear quite so early as on more sandy loams, as the growth of wood is more vigorous and fruit-buds are not so soon formed and matured, but they are more vigorous and hence less liable to the attacks of pests, and they live and bear longer. Apples, pears, gooseberries, raspberries, strawberries, and all kinds of fruit will do well on such soils, which, besides being richer in the constituents of plant food, retain moisture better than does a light sandy loam, which does not happen to rest on a stronger subsoil.

*Heavy loams*, with a large admixture of clay, make very good fruit soils if well drained, either naturally or artificially. Apple, pear, plum, apricot, cherry, and quince will thrive on such soils, and withstand the attacks of fruit pests with better result. On the heavier soils, pear and plum will do best of all, provided the climate suits the pear, which, in this respect, is more particular than the plum. Such soils are not so suitable for vines; in wet weather they are difficult to cultivate.

Heavy clay, unless deeply drained and limed, should better be left alone by the fruit-growers.

The site of the vineyard or orchard having been selected, it remains to clear it, if it has not yet been previously put under cultivation, and to prepare the soil for the plough. Autumn is the best time for ploughing, when the rain has softened the earth. Hand trenching is always a very costly operation, and, except when the patch to be planted is very small, is not practicable. The vine, however, like all other fruit trees that occupy the ground for a number of years, does best in a thoroughly stirred soil. The character of the soil regulates, to a great extent, the depth of the ploughing—a moderate depth is sufficient in rich loose loams, while conversely, in poorer soils or heavy clays, the plough should be run deeper. Where the ground is still raw and sour, with a cold subsoil close to the surface, it is advisable to have a leading plough turning a moderately deep furrow, followed by another plough with the mould board removed and stirring the ground deeper without bringing it to the surface.

It is reckoned that one inch of rainfall, covering one acre of ground, is equivalent to 100 tons of water per acre; similarly, taking the density of the soil as two, as compared with water, we get for

every inch deeper we stir the soil 200 tons of earth per acre, which, by being broken up become more easily penetrated by the rootlets of the plants in search of food. The soil at the same time is more thoroughly acted upon by air, warmth, and water, and reduced by their combined agencies during the process of weathering is rendered more healthy, more mellow, and quicker as a feeding ground for the plant. A deeper subsoiling has, besides, the advantage, which should not be overlooked, especially in a hot and dry climate, of promoting the growth of the roots well below the surface, and thus lessening the effects of drought.

In first ploughing or subsoiling in heavy and retentive soil, the furrow should always be in the direction of the fall of water, which might otherwise lodge in the subsoiler's tracks, and rot the roots of the plants in wet seasons.

Although heavy soils are those most benefited by thorough tillage, it is generally advisable, and experience has demonstrated that even in loose and shifting sands, a deep stirring is always accompanied by a corresponding vigour and increase of yield.

In most cases surface ploughing with deep subsoiling wherever practicable, should be recommended.

The most economical and the best plan of ploughing this class of land is to turn with an ordinary plough, worked by two or four powerful horses, according to the class of land, a furrow seven to eight inches deep, and follow up with a strong plough with the mould board detached, or a subsoil plough, drawn by a team of three to four horses.

The work can to a great extent be made lighter for the team in setting the plough so as to turn a narrower furrow, but the soil should be broken up as deeply as possible.

In some instances, deep subsoiling or trenching may be unnecessary, or not to be recommended, such as, when the surface soil consists of a very thin layer overlaying a substratum of loose and rubbly stones. In that case, the naturally brashy character of the subsoil, by permitting the roots to penetrate it, renders deep tillage either unnecessary or even inadvisable.

Under colder climates, when the soil does not receive much warmth from the sun—and this does not concern the Australian grower—the soil is stirred as little as possible. It is the custom there to plant thickly, so as to dwarf the vine and favour the growth of superficial roots, which will benefit by the full amount of heat from the sun's rays, while the grapes will be richer in sugar and the wine of a better quality. In Champagne and Burgundy, for instance, the soil prior to planting is only ploughed about 10 inches, as against 18 to 20 inches in the South of France and in Algeria.

In Australia a thorough stirring of the soil to the depth of 14 to 16 inches, according to localities and to soils, would certainly not

be excessive, and would soon repay its cost over and over again by the surplus yield resulting.

The best time for ploughing is after the autumn rain has softened the soil. After ploughing a thorough harrowing should be given, and as much couch and noxious weeds as possible removed and burnt.

The land is left in this rough condition all through the winter, then harrowed and ploughed crosswise—not subsoiled—late in the winter, and prepared for planting by means of more harrowing and rolling, if necessary.

Late ploughing in the winter will leave the ground dirty, as at the cross-ploughing a quantity of seeds of weeds will be brought to the surface, which will germinate and soon overrun the field; while, on the other hand, by early autumn and winter ploughing these seeds will germinate and be eradicated before planting time, while the land will be given a chance of getting thoroughly sweetened by the mellowing action of rain and air during the winter months, also the cuttings, as well as rooted plants, will in consequence strike better.

## DRAINAGE

is essential to the healthy growth of fruit trees. In well drained orchards the trees develop uniformly, but it often happens that even when the natural drainage is good, patches occur where the trees go off. There drainage is indicated.

Damp soil, on which sheep contract foot rot, liver rot or fluke, marshy stretches overgrown with rushes, sedge, or other water-loving plants, will not, unless properly drained, grow healthy fruit trees or vines. Marshy patches and water-logged soils are often to be met with on level flats or in hollows; occasionally also they occur on hillsides, when a bank of clay or a ledge of rock causes an accumulation of water and prevents its free escape. Whenever such conditions occur the soil must be artificially drained.

Moving water supplying moisture to the roots of plants and bringing air and warmth in its train is invigorating and life-giving; but stagnant, lifeless water, on the other hand, by favouring the decomposition of the organic matter in the soil, makes it sour, causes the emission of noxious gases, rots the rootlets of trees, limits the depth of soil they are able to feed on, starves them out, renders them liable to the attacks of diseases, and is utterly adverse to the healthy growth of trees.

There is a widespread idea that in a dry, warm country, with only a scanty rainfall during the growing months, the more water the soil retains, the better for the plant. This popular fallacy, however, stands no discussion. In the winter or the rainy season, such

soil is turned into a slushy bog, on which the operations of ploughing and digging are carried on under great difficulties and with little if any good results. During the hot, dry summer months, on the other hand, these quagmires dry up and turn as hard as bricks. What few roots the plants have been able to preserve from rotting during the winter months in turn dry up and perish in the baked soil in which the plant has been thus placed.

Draining may be said to sweeten the soil by checking the formation of the sour products of fermentation and rotting of the organic matter it contains; it also removes the excess of saline matters in the soil, and prevents alkaline salts from rising from below. It equalises the temperature of the soil, and prevents any possible chill to the plant. It restores to health plants suffering from attacks from fungus diseases. It brings warmth to the roots in the winter time and keeps them cool during the summer months. It deepens the layer of soil the roots of plants feed in. It favours the absorption and the circulation of air and moisture, and thus helps to pulverise the soil and unlock its fertilising elements, which are made available for the rootlets. Drainage of cold, damp ground favouring a higher temperature in the soil, hastens the growth of plants, and thus often brings on maturity of the fruit several days earlier.

Drainage is effected by several methods, viz., open drains or underground drains. Open drains again comprise arterial and surface drains.

*Arterial Drainage* embraces a comprehensive scheme for draining a large patch of country. This work is generally undertaken by the State, as its benefits extend not only to one or two particular settlers, but to the whole district at the same time. Such schemes have been carried out by the Government in the vicinity of the Harvey agricultural area, at Hamel, near Busselton, and other localities. The size of these drains depends upon the gradient; the less the gradient, the greater the capacity of the drains. In order to keep it clear of silt, a gradient of at least one foot per mile is necessary. Streams of smaller size require a gradient of three feet to four feet per mile, whereas minor ditches require at least eight feet per mile. In order to guard against the erosion of the sides and the banks being undermined by the water, the soil is cut open at an angle which varies according to its nature. In sandy soil an angle of 45deg. is required; in loamy soils, an angle of 60deg. or 70deg.; whilst clay may be cut almost perpendicularly, as it has much tenacity.

A velocity of three inches per second will remove fine clay; of six inches per second, fine sand; eight feet, sand; twelve inches, fine gravel; and 24 feet will carry off pebbles. Where the ground is

not too full of roots, an able-bodied\* man may dig from eight to ten cubic yards per day.

*Surface Drainage* is the more widely used system adopted by fruit-growers. Its chief objection is that it at times interferes with horse-cultivation. It is chiefly used for draining boggy land, and often prepares the way for deep drainage.

For draining a slope or cutting off water rushing from a rising catchment area on to a low flat below, these drains should be made almost at right angles with the flow and empty into a main drain below. The cost of making them is small, and if scoured before the wet season sets in they often prove amply sufficient for draining a piece of ground.

*Sinkhole Drainage.*—Amongst the limestone coastal ridges, swamps are often met with which have a retentive marly bottom. Underlying that hard pan, sand and limestone are again found. That marl is rich, but as the surface soil above is shallow, and for the greater part of the year partly under water, the ground is unfit for fruit culture. In other places a rotten ironstone conglomerate sometimes called “coffee rock” occurs below black mould. In such hollow localities, where water cannot be carried away by any of the other methods of drainage, holes sunk through the retentive hard pan often carry the water away into the porous soil below very economically. This is done with the pick or by blasting.

*Deep Drainage*, if costly, is, for cultivated fields, the most suitable system of improving wet land. Teams and implements can run without obstruction; weeds and rubbish are swept away, and have no chance of taking a hold of the land, and the greatest amount of benefit is derived from cultivated crops. It dispenses with open ditches and prevents surface wash, and consequently often great waste of fertility. The method consists in opening deep furrows or ditches, filling them partly with brushwood, logs, stones, or setting draining pipes in them and covering them up with the soil thrown out when excavating the ditch.

The grass trees (Blackboys, *Kingya*), which are plentiful in the moister region of Western Australia, where drainage is chiefly required, supply excellent material for drains. A trench is dug to the required depth, sufficiently wide to allow two blackboy trunks being laid side by side, the scales facing the way the water runs. Over these a third blackboy stem is laid, the three forming a triangular prism. The trench is then filled with earth, which is trampled down to counteract subsidence, and a crown one or two inches high is raked together along the line of trench to throw off heavy storm-water, which might carry away the freshly-dug earth in such places where a slope occurs. Blackboys, and more especially grass trees, on account of the resinous matter which is contained

in their scales, last a great number of years. Other material as well may be used, such as branches and stems of ti-tree or of jamwood, which stand a long time in the wet ground without rotting, are very suitable material. An effective material for filling drains is sand whenever it can be scooped or carted from an adjoining area. A box drain, four to six inches square, and constructed of jarrah board, and bored with holes made with an auger, would answer admirably. Rubble drains, where stone is available, are cheaply made, and very

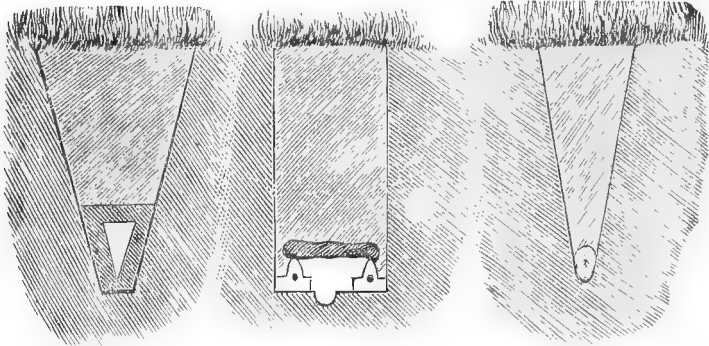

effective. In this method the drains are cut out in the bottom much wider than in pipe-making, so as to admit of two sidewalls of stone with a space between them. These side walls are built of narrow stones to a height of four to six inches, and flat covering stones, if available, occupying the whole width of the drain, rest upon them. If well done, this method of draining may be taken as almost as permanent as pipe draining; its chief objection being that it does not exclude such vermin as rats, rabbits, etc., and these mischievous animals soon choke up the drains by scratching soil in them.

Round tiles are in great favour in cultivated fields, but in the orchard I have seen instances where they utterly failed to answer the purpose they were laid down for. Forest, hedge row, and fruit-trees alike all seem to direct their roots towards the underground pipes where water and air freely circulate, and in many instances penetrate and stop up the drain as effectually as if a tow mop had been crammed inside. The failure of a single tile will cause much mischief. For this reason I feel diffident in recommending the use of draining tiles in the orchard. This system of draining is also costly, and cannot systematically be done under £8 to £12 per acre in this State, where both pipes and labour are costly. These pipes measure 12 inches in length, and vary from 1½ inches to 12 inches inside diameter. For short distances suitable pipes are two inch to two and a-half inch ones near the sources; for distances, say, over 100 yards, they should be increased near the mouth to three inches. Main drains, or collectors, require pipes four to twelve



inches in diameter. The bed of the trench should be smooth, firm, and even; the inclination of no drain should be less than half an inch or more than eight inches per chain.

The direction of the main drain should first be settled, and the minor drains are then mapped out in such a manner that the undulations of the surface are taken due advantage of in the way of securing a free and easy descent of the water. They should be placed midway between the rows of trees and, if possible, parallel with the fall, and lead into the main open drain that follows the natural watercourse. Laid on sand they are not so liable to become displaced. Great care must be taken that, though the surface be undulating, the pipe-bed has a uniform and even descent, and that there are no depressions in it where the water could lodge, eventually decomposing the pipes and filling up the drains with sediment. The depth of the main always exceeds by a few inches the depth of the laterals, which should be laid in a direction generally perpendicular to it, although where they enter the main drain that direction should be at an easy angle. These lateral drains, when laid fish-bone fashion on either side of the main drain, should not enter it immediately opposite, but should alternate to fit and adjust two pipes. The smaller one is chipped at one end, flute-shape, whilst a hole is knocked out of the larger pipe to receive it. The last pipe, at the outlet, is of iron, and its end is well grated to guard against the intrusion of vermin, whilst each of the minor pipes is also protected where it springs, to prevent earth and silt finding its way inside the drain and blocking it. Should a stoppage occur, an excavation is made and the cause, whatever be its nature—displacement of tile, accumulation of silt, or roots of trees—removed. A correct plan of the deep-drainage system is in every case necessary for future use.

The following table gives, for the character of the soil it is intended to drain, the distance apart the drain is generally set, the depth from the surface, and the number of 12-inch-long tiles required to the acre:—

Soil.	Distance apart, in feet.	Depth, in feet.	Pipes required.
Stiff clay ... ..	15	3	2,804
Friable clay ... ..	18	3	2,420
Strong loam ... ..	21	3	2,074
Gravelly loam ... ..	30	3	1,452
Light loam ... ..	33	3·6	1,320
Sandy loam ... ..	40	3·6	1,089



The fact must not be overlooked that, if the drain is too shallow, the water will run directly to it without benefiting the soil with its fertilising power; if too deep, it will cease to draw, and will not work.

*Sand Drains.*—Some years ago I saw at Mr. Briggs' farm at Jandakot, near Fremantle, an efficient substitute for deep-laid draining pipe. Whereas these cost to lay £6 to £10 an acre, the sand drains, which never wear or require repairs, can be provided for less than half the money. This method, which has also been successfully used near Edinburgh, consists in cutting the trenches, which on a large scale is done by specially constructed trench diggers, and filling these drain channels with coarse sand or gravelly soil.

Drains will act in porous soils much greater areas than in stiff soils. For instance, in porous, free soil, a drain will lay dry eight to nine feet wide for each foot it is in depth; in soil of medium consistency, six to seven feet, whereas in heavy soil it will only draw four to five feet for each foot it is in depth. Whatever the case may be, if draining is worth doing at all, it is worth doing well; and it is money saved and efficiency attained to drain five acres perfectly than ten imperfectly, and leave the five until this work can be properly attended to.

In conjunction with systematic and extensive irrigation especially, and whenever the subsoil is not sandy or gravelly, but is of a somewhat retentive nature, drainage becomes essential to the fruit-grower, and in considering its cost he should bear in mind that fertile drained land will show an increase in the yield by 20 to 30 per cent. compared with undrained land under similar conditions.

### SHELTER TREES.

Much damage is caused to fruit-trees in exposed places by high winds howling through the orchard, breaking branches, withering up tender leaves, as well as blossoms, and throwing the trees out of shape, stunting them, and making them set early.

Whenever natural shelter from a range of hills, a belt of forest, or the natural slope of the ground can be utilised, it should be taken advantage of. If natural shelter does not exist, an artificial one must be provided before or at the time of planting. If the live hedge can be dispensed with, however, so much the better. A quick hedge growing round a vineyard or an orchard harbour bird pest and will rob the trees of their nutriment, unless means are taken of preventing them doing any harm.

Many of the trees used for the purpose, such as the olive, the black wattle, the white boxthorn, the mulberry, are at times attacked with scale insects, which, unless kept down, would soon infest the fruit-trees. A quick hedge is, however, sometimes necessary for the protection of vineyards and orchards situated near a town, a village,

or along a public road. Should a hedge be found necessary, a deep trench about two feet deep should be run along it so as to cut off the growth of the roots towards the direction of the vines or fruit-trees.

A short description of a few hardy plants which have proved suitable for the purpose, taken mainly from von Müller's "Extra Tropical Plants," will prove of use to those who require wind-breaks for their orchards or gardens:—

**ALMOND TREE** (*Amygdalus communis*, Linné).—From Caucasus. Resists drought well, and yields a valuable crop. The cost of gathering the crop in South Europe is about 20 per cent. of its market value. The flower affords to bees, early in the season, nectar and pollen. There exists hard and soft-shelled varieties of both the sweet and bitter almonds. Can even be grown on seashores. Further information is given concerning the almond in a subsequent chapter.

**BAMBOO-REED** (*Arundo Donax*, Linné).—The tall, evergreen, lasting bamboo-reed of Northern Europe, South-Western Asia, and Northern Africa, is fairly hardy, and attains a height of 20 feet and more. One of the most important plants of its class for quickly producing scenic effect in picturesque plantations, also for intercepting almost at once, the view of unsightly objects, and for giving early shelter. The canes are used for fishing-rods, for light props and various utensils. Easily transplanted at any season. Rows or belts of it intercept sewage or exsiccate stagnant drainage. Pasture animals like to browse on the young foliage. Dr. Bancroft, in Queensland, proved this plant a splendid "stayby" in seasons of drought, and recommends reserve fields of it regularly to be kept.

**THE CAROB TREE**, synonym Locust Bean (*Ceratonia Siliqua*, Linné).—One of the best, if not the best, shelter tree for this State. Indigenous of the Eastern Mediterranean regions; attains a height of 40ft. to 50ft., and resists drought, hot winds; succeeds well in all kinds of soils—rocky, gravelly, hilly, but thrives more particularly on calcareous subsoil, and on deep fertile loams. Would grow in this country at all altitudes. Splendid specimens of it grow near Geraldton and at New Norcia and also at Pinjarra, yielding annually two to three hundredweights and more of saccharine pods; of great value as stock food, and worth for that purpose, when crushed, 5s. to 6s. a cwt. The exportation of the pods from Cyprus, Crete, and Syria is very large. In most of the Mediterranean countries horses, cattle, and pigs are almost exclusively fed, during the dry months of the year, upon the pods, which contain 50 per cent. of sugar and gum. The meat of sheep and pigs is greatly improved in flavour by this food. At Gibraltar, Malta, and in Egypt the fine commissariat mules are fed with a mixture of Carob beans and pulse; to horses and cattle 6lbs. a day are given of the crushed pods, raw or boiled, with or without chaff.

For a wind-break the trees should be planted in double or single rows, 12ft. to 15ft. apart, when their evergreen branches will entwine and resist the most fierce wind. The tree is very symmetrical in growth, and highly ornamental in paddocks, where they afford in copses or singly a good shelter for stock. As a road border, or in avenues, it also affords a striking effect. It stands clipping well. It grows quicker than the Olive tree; the gathering of its fruits, which are knocked down by means of long poles, is easier, while the pods can be bagged or stored away for a long time without loss. In the proximity of orchards, it moreover offers over the Olive tree the marked advantage of being pretty free from insect pests, and more especially the black scale that finds in the Olive a favourite host plant. This disadvantage has, however, now disappeared since the fly parasites of that scale have been successfully introduced into this State.

The Carob trees are propagated from seeds, which, being hard, require soaking for a few days. When the germ begins to show they are sown in seed beds, preferably in ground with a hard sub-soil, so as to check the downward growth of the tap-root. After a fortnight or so the young plants begin to show. When about three feet high, in one year or two, they are transplanted in a nursery, cut back to 12 inches or so, and the year after they are grafted with scions from some prolific tree, bearing large pods. Unless this is done, many of the trees will prove sterile. The frequent unisexuality of the flowers accounts to some extent for the want of productiveness in fruit of this plant when few trees exist, or this sterility may be traceable to insufficiency of lime or other substances in the soil. After a year or two in the nursery the young trees are planted out, suckers are rubbed off, and, after two or three years' cultivation, will yield three to four cwts. of fruit without further cultivation. On the Swan the pods ripen in March, when blossoming also takes place.

**BRACHYCHITON POPULNEUS**—One of the currajongs. From Gippsland to Southern Gippsland a splendid avenue tree, recommended for its pyramidal growth, evergreen shining foliage, somewhat variable in shape, and short stout branches which render it almost wind-proof. Succeeds well on rocky and dry ground, and is comparatively easy to transplant even when of good size. Leaves eaten by pasture animals. Allied to the "flame-trees" of Kimberley; makes a gorgeous display of coral-like inflorescences.

**THE BITTER ORANGE** (*Citrus Bigaradia*).—Very suitable for avenue planting in the towns of the citrus belt, and much used for that purpose in Southern Europe, where it is trained with a clear stem 6ft. to 8ft. high, and a regularly-shaped crown. Very attractive on account of its beautiful aromatic foliage, delicious blossoms, which furnish the Neroli oil, and golden fruit, the rind of which is

used for candied orange-peel and marmalade; produced all the year round. Furnishes one of the best stocks for orange grafting.

CYPRESS (*Cupressus macrocarpa*, Hartweg, and *C. Lambertiana*, Gordon).—California; grows in the granite, as well as sandstone formation, sometimes in Sphagnum-moors. A beautiful and shady tree, attaining to a height of 150ft., with a stem of 9ft. in circumference; it is one of the quickest growing of all conifers, even in poor dry soils; does well also on limestone soil, and is one of the best shelter-trees on sea-sands, naturally following the coast-line, never extending many miles from the shore in temperate localities. Not to be planted in places where stagnant humidity exists underground, nor where the soil is but little penetrable. Not a long-lived tree.

FIG (*Ficus carica*, Linné), Syria and Persian Gulf.—The most useful and at the same time most hardy of half a thousand recorded species of *Ficus*. The extreme facility with which it can be propagated from cuttings, the resistance to heat, the comparatively early yield and easy culture recommends the Fig-tree, where it is an object to raise masses of tree-vegetation in widely treeless lands of the warmer zones for shade and fruit. Has a high reputation as a drought-resisting tree. Can be grown even on sand lands. Two main varieties may be distinguished: that which produces three crops a year, and that which yields but one. The first crop of figs grows on wood of the preceding year; the last crop, however, on wood of the current year.

THE "LOQUAT" (*Photinia eribotrya*, J. Hooker, *P. Japonica*, Franchet and Savatier), a beautiful ornamental and quick-growing evergreen shrub from China and Japan, easily raised from seed, or superior varieties can be grafted not only on its own stock, but also on the white thorn, or better still on the quince. Bears copiously on moist places. In Australia flowers during mid-winter. The flowers of this beautiful shrub are also very fragrant, and its fruits are about the first to ripen, about August and September.

CAMPHOR TREE (*Cinnamomum camphora*), China and Japan.—The trees are very attractive for their neat, fragrant foliage. Endures a slight frost. The wood, like all other parts of the tree, is pervaded with camphor, hence resists the attacks of insects.

MULBERRY.—The White Mulberry (*Morus alba*, Linné), upper India and Western China. Provides the food for the Chinese silk-worm (*Bombyx Mori*). One pound of silk may be produced—so far as the food of the *Bombyx* is concerned—from thirty pounds of mulberry leaves or from a single tree. Grows easily from cuttings or from well matured seeds. It is usually unisexual, and attains a very large size. Spots for mulberry culture must not be over moist when the leaves are to be utilised for the *Bombyx*. For sericulture purposes the trees are planted 10ft. x 10ft., and, kept at bush size, make good hedges or copses.

The BLACK MULBERRY (*M. nigra*, Linné) of Persia, grows into a large tree; valuable for its pleasant refreshing fruit, which can also be fermented into a vinous beverage. Well adapted for sandy coast ridges; the leaves, although not so good as *M. alba*, afford food for the ordinary silk-worm. It is said that wherever mulberries grow that most destructive frugivorous bird, the "silver-eye," concentrates all its attention to its fruit and thus keeps away from the vines. This tree would, in that case, prove a most useful auxiliary to the fruitgrower in keeping this feathered enemy away from the orchard and the vineyard where the ripening of the Mulberry is concurrent with that of the fruit crop intended to safeguard.

MYROBOLAN PLUM (*Prunus cerasifera*, Ehrhart, and *P. Myrobolanus*, Desfontaines).—The Cherry Plumtree, of which there are several varieties: the Red, the Yellow fruited, and the *Pissardii*, which has a rich claret coloured foliage and early white flowers and fruit of the same colour as the foliage. Countries at and near the Caspian Sea, of rather tall growth. The fruits called also Mirables (which name is given to some varieties of *P. domestica* as well), whence long ago the objectionable designation Myrobolan cherry-plum arose. Flowers very early and before the development of its leaves. Splendid for hedges; grows vigorously in the poorest soil; ramification impenetrably dense; bears almost any extent of clipping; not hurt by exposure to sea air. Planted for hedges in two rows 18 to 24 inches apart.

OSAGE ORANGE (*Maclara aurantiaca*, Nuttall), Texas, Arkansas, Louisiana. This thorny deciduous shrub can be well trained into hedges; unisexual, resists severe frosts, on rich river banks grows to a great height, valuable for all purposes where toughness and elasticity are required. The plant is not readily subject to blight or attacks of insects. The foliage is as good a food for silk-worms as that the white mulberry.

Makes one of the best hedges for this climate, being, if kept in order, close and almost impenetrable to stock or trespassers. Propagated by sets; the line of fence having been marked, the soil should be stirred to a good depth. Sets should be planted in a double row, sets being six or eight inches apart and the rows ten to twelve inches apart. Press the soil firmly to the sets. If a hedge is planted on sloping ground a furrow or ditch should be run along the line of the upper side to protect the hedge from being worked away. A deep trench should be run between the hedge and the first line of vines or trees for the purpose of keeping the roots from trespassing on the cultivated land. Osage orange hedges are said to not harbour small birds as most quick hedges do, and for that reason are recommended, as small birds do enormous damage at times to the vines.

PEPPER TREE (*Shinus Molle*, Linné).—A fast-growing ever-green shrub or small tree of the cashew family, native of South

America and Mexico, and cultivated for ornament and shade in Southern California, Australia, and other warm dry climates; will bear droughts and intense summer heat of Central Australia better than almost any introduced plants. *S. Terebinthifolia*, from Brazil, form fine promenade trees in Victoria, Algeria, and Tunis, having a better habit and richer foliage than the preceding.

PITTOSPORUM, of which there are several varieties, but they are all suitable for shade-lines when celerity of growth is not an object. They are perennial; always look clean. The flowers are fragrant and yield a volatile oil on distillation. The trees are always clean looking; they stand clipping well.

THE CLUSTER PINE (*P. maritima*, De Candolle, *P. Pinaster*, Solander).—For ease of rearing and rapidity of growth, one of the most important of all pines. Trees about 15 years old can be cut for sawing into fruit cases. Planted closely at a distance of 8 to 10 feet apart to ensure the growth of a straight stem with few latent branches and wood knots.

This pine has been much used for consolidating the sandy coast along the shore opening on the Bay of Biscay. The mature trees are then regularly tapped for turpentine before they are felled and the timber utilised. This pine, which does well on sandy stretches, is more valued by foresters than is the *P. insignis*, also a valuable tree.

POMEGRANATE (*Punica granatum*, Linné).—North Africa and South-Western Asia; widely cultivated for its showy flowers and fruit; much overlooked regarding its value as a hedge plant; will grow freely from cuttings. Purposely cultivated in Algeria for walking sticks. Passed with very few other plants through years of drought in Central Australia. The best varieties are propagated by grafting; among these there is a practically seedless variety known to Indian cultivators.

PRIVET (*Ligustrum Japonicum*, Thunberg).—The Japan Privet, a shrub evergreen or nearly so, promising to become a valuable hedge plant. Grows readily from cuttings, like the ordinary European privet, *Ligustrum vulgare* (Linné). Both will grow under trees, where scarcely anything else would live.

QUINCE (*Pyrus Cydonia*, Linné, and *Cydonia Vulgaris*, Persoon).—The Caspian Sea, one of the hardiest of orchard trees, and serves a great many useful ends. Raised by cuttings or by layers which strike root freely. Frequently used as a stock for other trees. Very little pruning is required; extensively used as a hedge or screen.

TAGASASTE (*Cytisus proliferus*, Linné fil.).—Canary Island. A fodder shrub for light dry soil; finally tall, rather intolerant to frost and drought. Valuable also for apiarists. In some places it

was found that horses and cattle dislike this plant as nutriment. It grows quickly again when cut.

THE TREE TOBACCO (*Nicotiana glauca*, Graham).—Argentina and Uruguay. Grows amazingly on the sandy country around Perth, Geraldton, etc. On the Greenough flats I saw a most efficient break-wind made of this quickly-growing arborescent species, planted 3ft. to 4ft. apart; with stems half cut through at a height of 2ft. with a tomahawk, bent down almost at right angle, and tied up to the next plant. From these curved stems numerous strong shoots grow straight up, and as they are very elastic and almost unbreakable by the wind, make very efficient shelter hedge. One of the best of plants to establish, shelter and stay the shifting of the sand waves, where the poisonous property of its foliage is not objectionable. It is inadmissible to pastoral places on account of its deleteriousness.

THE WEeping WILLOW (*Salix Babylonica*, Tournefort, *S. pendula*, Moench).—North China. One of the quickest growing and most easily reared of all shade trees. Pasture animals browse on the young foliage. The tree is important for consolidating river banks, a powerful scavenger of back yards, but apt to undermine masonry and to get into cisterns.

THE BITTER WILLOW (*S. purpurea*, Linné), Europe, Northern and Western Asia, one of the osiers. In deep, moist soil, not readily otherwise utilised, it will yield annually per acre four to five tons of the best rods, qualified for the finest work. Impenetrable, not readily inflammable; screens as much as 25 feet high can be reared from it in five years. This species is not touched by cattle. For hedges, cuttings are planted only half a foot apart, and must be entirely pushed into the ground. To obtain additional strength, the shoots can be interwoven. Grows well on light soil or warpland, and will grow fairly well on gravelly soil, but not on clay. No basket willow will thrive in stagnant water; humid places should therefore be drained. The cutting of the shoots is done close to the ground after the fall of the leaves. The accidental introduction from abroad of destructive saw-flies (particularly *Nematus ventralis*), which prey also on the currant and gooseberry bushes, should be guarded against.

THE COMMON OSIER (*S. viminalis*, Linné), Europe, Northern and Western Asia. Height, to 30 feet. The best of basket willows for banks subject to occasional inundations. A vigorous grower, very hardy, likes to be fed by deposits of floods or by irrigation and disposes readily of sewage. One of the best for wicker-work and hoops. One of the best willows for copses and hedges, very quick growth and foliage, giving deep umbrage.

WATTLES (*Acacia*).—Quick growing indigenous shrubs or middle-sized trees of striking beauty when in bloom, and valuable



for the tannic acid contained in the bark used in making hides merchantable. A great variety of these offer for selection, notably the "Black Wattle" (*Acacia decurrens*) of New South Wales, and (*A. mollissima*) of Tasmania. The feather-leaved varieties of wattles containing, according to localities, 15 to 30 per cent. of tannic acid in the dried bark. Their cultivation is easy; the seeds, which retain their vitality for several years, are soaked in warm water before sowing, and thrive anywhere, particularly away from the coast or ironstone gravel formations or poor sandy soil with a clay subsoil to retain the moisture. The bark can be stripped in from five to ten years, and is worth £10 a ton in Melbourne. The wood is tough and can be used for staves, and supplies an excellent fuel. The "Golden Wattle" (*A. pycnantha*, Bentham), of Victoria and South Australia, thrives on poor coastal land, where *A. mollissima* would not grow.

In all cases proper attention should be bestowed on the live hedge, more especially during the early period of the growth of the trees, which should be trimmed periodically to secure a close base growth. Nothing looks more unsightly and is less efficacious than a badly kept life fence.

#### FENCING.

In the first edition of this Handbook Mr. L. L. Cowen (late secretary to the Bureau of Agriculture) thus summarised the question of fencing:—

"This Handbook is intended as much as a guide to the new-comer as to those already settled upon the land, and it would not be complete without a few words on fencing. In the more thickly settled districts vermin have almost disappeared, and any fence that is sheep-proof will be found to suit the vine and fruitgrower. The pioneer or the settler in a sparsely populated district will have to fence out vermin—boodey rats, opossums, and other rodents, which will, if permitted, commit incalculable havoc in a young orchard or vineyard. Fortunately, there is neither the rabbit nor the hare\* to be reckoned with; but the "boodies" and 'possums will be found to sorely try the patience of the settler. Particularly the latter, and it is a question whether such a thing as a 'possum-proof fence has yet been invented. To fence out ground vermin is not a difficult matter, but to fence out the 'possum taxes one's ingenuity very severely.

"Before proceeding to discuss the different classes of fencing, it might be well to say a word or two about the different kinds of timber generally used in this State. The new-comer cannot do

---

\*The rabbit has since invaded portion of Western Australia, but no serious trouble is anticipated from the pest in fruit land.

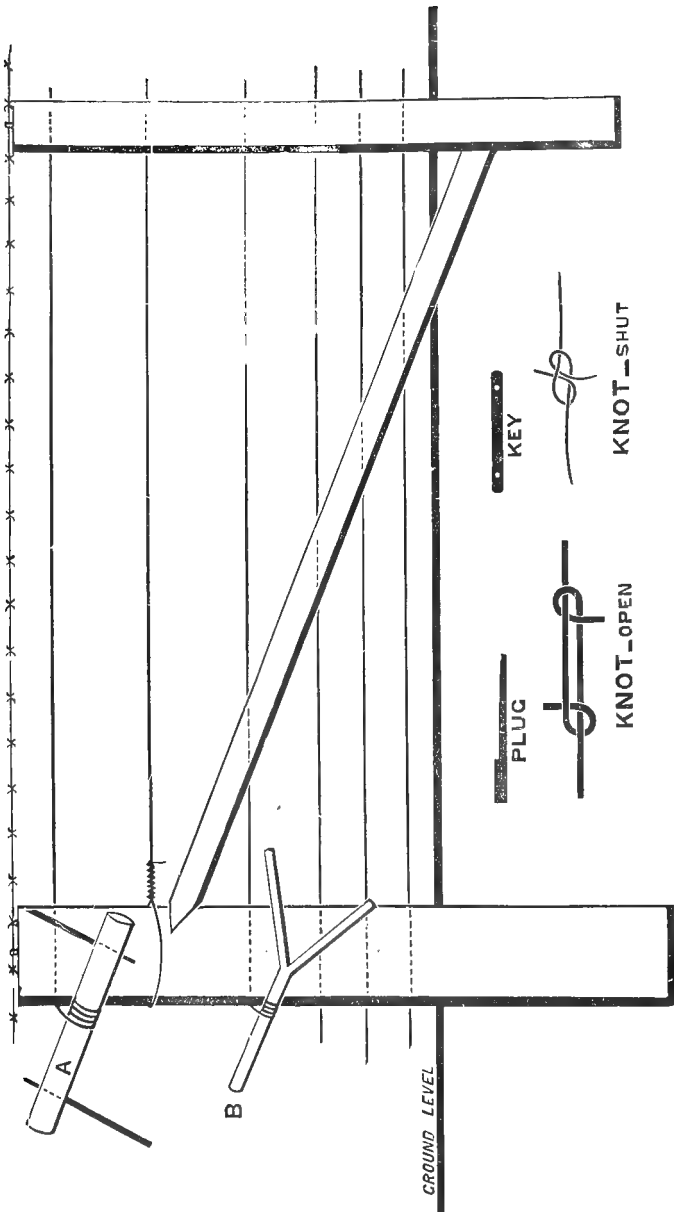

Diagram of fence showing strut on straining post, straining and tying devices.

better than be guided in the selection of the timber by the experiences of those already settled in the district in which he purposes to make his home. It must be remembered that the white ants (*termites*) are omnipresent, and only timber which these voracious insects dislike should be used for posts. The wood of the raspberry jam (*Acacia accuminata*) stand pre-eminent for durability and its ability to resist the attacks of white ants. Jarrah (*Eucalyptus marginata*) is deservedly popular for fencing, but only good wood should be used, as in some localities, and under certain conditions, it is known to succumb to white ants. The new-comer will find a good deal of diversity of opinion expressed as to the value of various kinds of wood. There is no doubt that the white gum, for instance, growing in certain parts of the State, is a wood of the greatest durability, while that found growing in another locality, perhaps not far removed, is comparatively worthless for underground work. The same thing applies to other timbers, and the new-comer will do well to be guided by the experience of those amongst whom he intends to settle.

“Charring the posts at the ends which will be in the ground adds to their durability, or they may be well smeared with coal tar. Wherever it is possible it is always better to use timber that has had a chance to season, in preference to putting in posts direct from the stump, and full of sap.

“Where ground vermin only exist, wire netting trenched into the ground six inches, with two top wires, will make an excellent fence. But, where the festive opossum disports himself, fruit-growers will have to take more elaborate measures to prevent the intrusion of this most pestiferous and importunate rodent. In the first place, all overhanging trees should be cleared from around the boundaries. It is advisable to do this in any case, and a little more money spent at the first in thoroughly clearing the line is invariably a judicious investment.

“It is a difficult matter in putting on wire netting to stretch it so as to take out the bagginess. Ordinarily this fencing is slack and very untidy. It needs to be thoroughly stretched. To do this

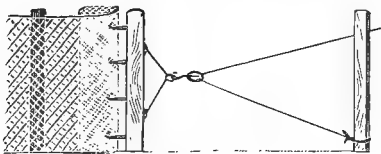

the plan shown in the sketch may be used to advantage. A strip of board has four or more hooks arranged on one side to hold the roll firmly and to stretch each section as it is unrolled. A pulley

attached to the following post draws the netting tightly past the preceding post, where it is secured firmly with staples and the work advanced to the next post.

"Gates are a most important feature in a fence, and where paddocks have to be protected they are absolutely necessary. The following is an illustration of a cheap and very satisfactory gate which I have had in use now for some years:—

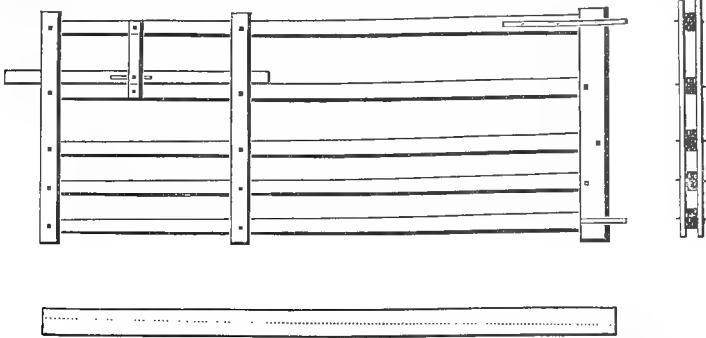

"The largest piece of timber in the gate is 6in. x 1in., and there are no mortices to work loose. The timber for a gate—jarrah, karri, or any hard wood—can be purchased at the mills for 8s., the bolts for 3s., and the strap hinges top 18in. x 2in.,  $\frac{3}{8}$  iron, bottom 6in., and hooks cost 6s. the set; total 17s. Any one who can use a saw and a brace and bit can put a gate together and hang it in two hours and a half. Putting the labour down at 1s. per hour, this brings the total cost of the gate up to £1, if you have to pay for labour. Here are the quantities for a gate 12ft. x 4ft. 6in. high:—

"Two pieces, 7in. x 1in. x 4ft. 6in., for hanging stile; four pieces, 3in. x 1in. x 4ft. 6in., two each for closing and middle stile; two pieces, 3in. x 1in. x 9ft., for diagonal brace; three pieces 7in. x 1in. x 12ft., for rails; one piece, 3in. x 1in. x 5ft., for latch; two pieces, 3in. x 1in. x 1ft., for packing top hinges.

"Bolts.—Two, 4 $\frac{1}{2}$ in. x  $\frac{1}{2}$ in., one each top and bottom hinges; two, 4 $\frac{1}{2}$ in. x  $\frac{3}{8}$ in., for top hinges; eighteen, 3 $\frac{1}{2}$ in. x  $\frac{3}{8}$ in., for fastening stiles and braces.

"Rails.—Take the three boards 7in. x 1in. x 12ft. and mark off 4in. at one end and 3in. at the other. Run a line and rip down diagonally. This will give you six rails 4in. wide at one end, tapering to 3in. at the other. Five rails will be wanted for the gate. The mill will do the ripping for you if you like. This is the only real work there is in the gate. Lay on the ground on chocks sufficiently high to get your hand under so as to get the bolts in one side of the hanging stile 7in. x 1in. x 4ft. 6in., and 8ft. from this and parallel to it the middle stile 3in. x 1in. x 4ft. 6in., and 4ft. further on again the closing stile 3in. x 1in. x 4ft. 6in. Whatever the length of your gate, the middle stile should be two-thirds of the whole length from the hanging stile. Lay on these pieces the

five rails any distance apart you like, only be sure and have the 4in. ends all at the hanging stile and the *saw cuts turned alternately*. This is most important, as herein lies all the strength of the gate. When you have laid the rails on the top of them, place the other hanging, middle and closing stile pieces; get our brace and bit and bolts, and bolt the whole lot together, putting in a  $\frac{3}{4}$ in. bolt at each intersection, reserving the two  $\frac{1}{2}$ in. bolts for the hinges. When the gate is bolted together, turn it up on edge, square it, tighten up all the bolts, and then put the braces on, one on each side, running from the foot of the hanging stile to the top of the middle stile. Bolt with  $\frac{3}{4}$ in. bolts at each intersection. Then put on your hinges and latch—a sliding piece 5ft. long, with two chocks on it to prevent it shooting too far, is as good as any—hang your gate, and the thing is done. A coat of Washington whitewash, which is about a tenth the cost of paint, and very durable, and you have in your gate ‘a thing of beauty and a joy for ever.’

“*Washington whitewash* is so named from the fact that the White House at Washington, the official residence of the President of the United States, is coated with it. It is made as follows, and if properly made will neither wash off nor rub off, and has all the appearance of paint:—Slack a bushel of quick lime in a barrel, covering with a bag while the lime is working. Melt 1lb. of common glue to a thin size. Make  $1\frac{1}{2}$ lbs. ground rice into a thin paste with boiling water. Mix up 1lb. of whiting as you would mustard. When the lime is quite slaked add the glue, whiting, and rice paste, and half-peck of common salt. Mix well and let stand for 48 hours, keeping covered. Thin down to consistency of ordinary whitewash and apply hot.”

#### FENCING MATERIALS.

##### *Black and Galvanised Steel Fencing Wire.*

Per Ton.*		Gauge.	Length per cwt.	Weight required per Mile.				
Black.	Galv.			1 Wire.	2 Wire.	3 Wire.	4 Wire.	5 Wire.
£ s.	£ s.	No.	Yds.	c. q. lbs.	c. q. lbs.	c. q. lbs.	c. q. lbs.	c. q. lbs.
10 10	12 0	6	469	3 3 0	7 2 0	11 1 0	15 0 0	18 3 0
10 10	12 0	8	586	3 0 0	6 0 0	9 0 0	12 0 0	15 0 0
10 15	12 10	9	727	2 1 19	4 3 10	7 1 0	9 3 20	12 0 11
10 15	12 10	10	880	2 0 0	4 0 0	6 0 0	8 0 0	10 0 0

\* The prices quoted are pre-war prices.

4-point thick set barbed fencing wire (448 yards per cwt.) £16 per ton.

##### *Wire Netting, in rolls of 50 yards.*

Mesh.	Width ...	...	24in.	30in.	36in.	48in.	60in.	72in.	
1½in.	Price per yard	...	2½d.	3d.	3½d.	4½d.	...	...	per yard
2in.	“	“	2d.	2½d.	3d.	4d.	4½d.	5d.	“
3in.	“	“	1½d.	1¾d.	2d.	3d.	3½d.	4d.	“

## LAYING OUT THE GROUND.

After the land has been cleared, ploughed, and harrowed, the laying out of the ground is the next thing to attend to.

Planting is done on—1° the square, 2° the diagonal, 3° the hexagonal or equilateral or septuple, 4° the quincunx.

On extensive areas of undulating land, it is advisable to set off the land with a theodolite, or employ a surveyor to do the work, so as to ensure precision. There are, however, simple methods of carrying out this work which anyone can follow, and which rest on geometrically accurate propositions.

In any case it is essential to start from a *base line*.

A surveyed line for this purpose is generally to be found alongside the field of operations, as roads and boundaries lines.

A rough computation of the area to be planted is made by pacing two sides of the field, length and breadth, reducing the number of yard steps to chains, viz., 22, multiplying the number of chains obtained and dividing the quotient by 10.

For conducting measuring tests, etc., on small areas, the following table is useful, showing the side of a square to contain:—

1 acre	...	...	208.7 ft. or	70 paces
$\frac{1}{2}$	"	...	147.6 "	50 "
$\frac{1}{3}$	"	...	120.5 "	40 "
$\frac{1}{4}$	"	...	104.4 "	35 "
$\frac{1}{8}$	"	...	73.8 "	25 "

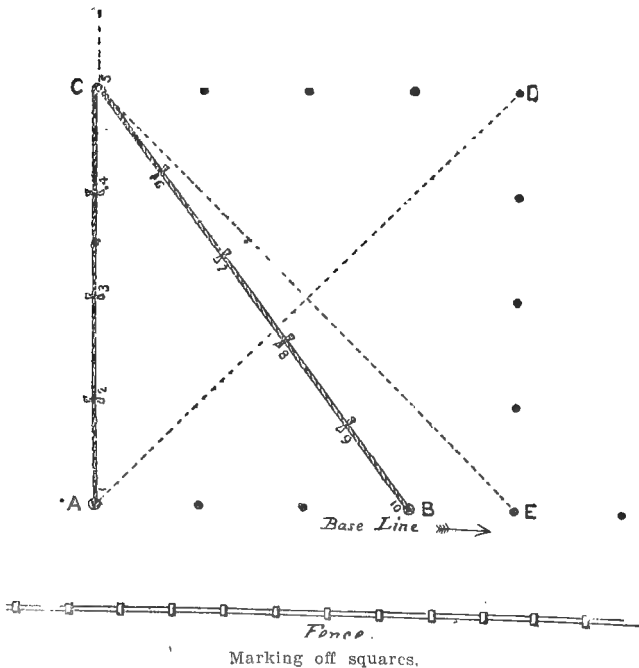

1°. *Square* planting seems the simplest plan of laying out an orchard, but it will be seen that the others are just as easy.

The base line having been traced, which can be done by measuring the width of a proposed roadway or headland from, say, a line of fence to the first row of trees or vines to be planted, pegs are set in the ground, so that the two lines: fence, and row of trees are parallel. A roadway of 20 feet at least is necessary to allow the horses and implements to turn at the headland. On this line, as a base line, a right angle corner is traced thus:—First, along the base line of the given piece of ground to plant, measure with the tape three intervals of, say, 10 feet each, putting pegs at each distance. Secure a flexible line, such as picture wire, marked off into nine or more 10-foot intervals by means of string or strips of calico; set one end of that line at the corner peg A, where the first vine or tree is going to be planted, then stretch it as correctly as guesswork will permit in a direction perpendicular, or at right angle to the base line, and at the fifth mark which shows the fourth interval drive down a peg; round this peg turn your wire, and bring it to the peg B, driven at the third interval along the base line. If the mark along the measuring line meets the peg B along the base line A, E, then the angle B, A, C is a right angle; if it does not, shift peg C

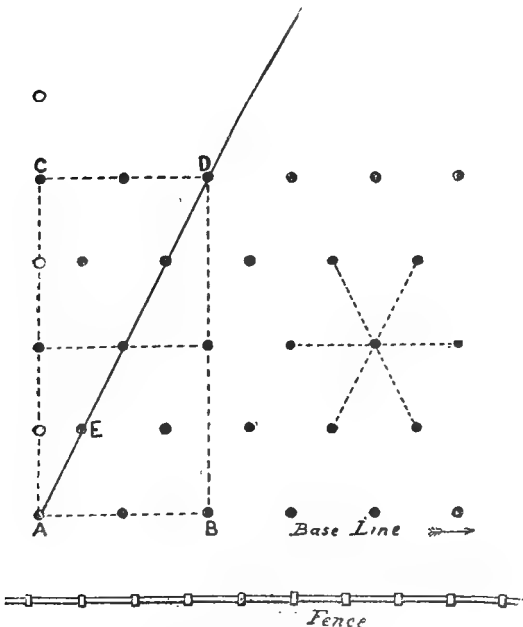

Setting off diagonal planting.

until the tenth mark or end of the ninth interval along the measuring line connects with peg B on the base line. It is geometrically true that in every instance where the three sides of a triangle are as 3, 4, and 5 the angle opposite the hypotenuse or the longest side is a right-angled triangle.

Another method, which may be used as an alternative, consists in guessing a triangle and measuring the diagonal distances between the opposite corners A, D and E, C on the same figure; unless those distances are equal to a fraction of an inch the square is not perfect, and by manipulating and shifting the pegs until those two lengths coincide the desired lines running at right angles to one another can be planned out.

2° *Diagonal planting* has few, if any, advantages. As shown in Figure 2, the base line is first determined and a true corner found as in the case of the square. On the lines thus determined rows of trees will be set. The alternate rows are obtained by running with a line a diagonal from *two* squares which have already been mapped out. From the corner A, mark off one-fourth distance along this diagonal and you have the spot where the first tree along the second row will stand; from these points plot out parallel lines to A B, A C, etc., and along these lines mark off the required distances as had already been done on the base lines.

*Another method* to set out diagonal lines: start in the same manner as for marking on the square; stretch the planting lines and omit every alternate intersection.

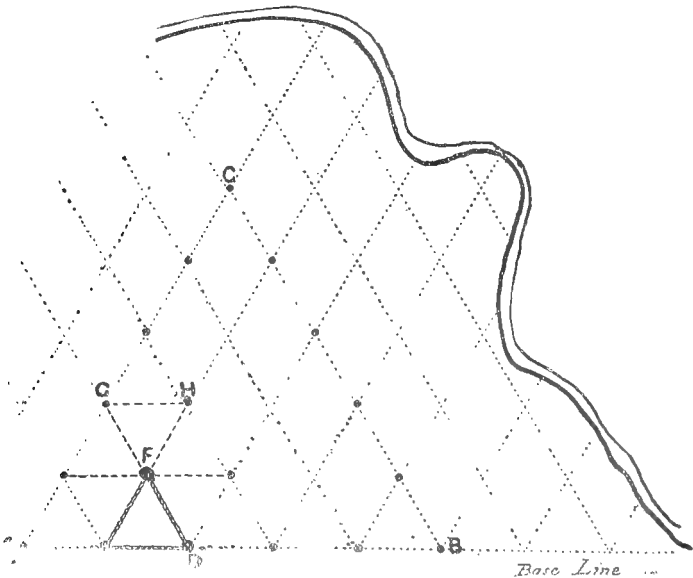

Hexagonal or septuple planting.



3°. *Hexagonal, Equilateral, or Septuple* planting, so called because either seven trees enter into its figure or it consists of six trees—disposed after the six-sided figure of the cells of the honey-comb—and enclosing a seventh tree, or because each tree is equidistant from any other tree around it. By this method of planting less ground is occupied, and while the roots of every tree has theoretically the same amount of ground to feed on, assuming that the roots spread evenly round the stem, it is at the same time possible to set fifteen per cent. more trees to the acre as compared with square planting, and cultivation can be carried out in three different directions.

The hexagonal is as easy a method of plotting a piece of ground as is the square.

To lay out a piece of ground for septuple planting: Determine the base line; peg along it a few equal spaces it is desired to plant the trees at, say, for argument's sake, five intervals of 22 feet each, the distance between A and B along the base line is thus 110 feet; one end of two lines also 110 feet each are fastened at the pegs A and B and are drawn together taut until the other two ends meet at C. Along the lines A C and B C mark off likewise five intervals of 22 feet each, and fill in the triangle as shown on the figure. Once the equilateral triangle is set, the lines are prolonged to whatever limit it is intended to reach, and where they intersect pegs are put in. Be the piece of land regular, or the boundaries irregular, as happens, for instance, when a vineyard or an orchard is planted on a river bank, the rows will all be in symmetrical lines. Another easy method of laying out hexagonals with a triangle is also shown on the above figure. Three pieces of flexible wire, such as light clothes lines, are cut precisely the same lengths, their ends are spliced to rings two inches to two and a-half inches in diameter as shown in the above figure—the sides E D, D F, and F E are equal. Place one of the sides, say E D, along the base line, and drive pegs at E and D; stretch the third angle until the other two sides of the triangle are taut, and drive likewise a peg through the ring. Then round the peg F as a centre revolve the triangle right round, stretch the side lines taut, and drive short pegs straight down through the centre of the rings at G and H. Next move the wire triangle to the next distance and do likewise, repeating the operation until the end of the row is reached. In this way a man and two assistants can mark out three rows with the greatest accuracy, provided that they always ascertain before driving the peg into the ground that the lines are reasonably tight. On flat, even ground the triangle can be stretched flat on the surface of the ploughed land; but on sloping ground a little levelling is required, the triangle being stretched as nearly horizontal as possible by raising one or two corners as required, and a stake driven down plumb to the right spot.

The *Quincunx* is a method involving groups of five trees, the fifth tree occupying the centre of a square. It is only useful where

long-lived and slow-growing trees such as the Olive are planted, when it may be desirable to set amongst them some quick-growing but short-lived trees, such as peaches, nectarines, or Japanese plums, which will begin bearing early and can be cut down to make room for the longer lived trees, when after ten or twelve years their period of usefulness is on the wane. For laying out this system squares are first lined, then diagonal lines are drawn from opposite corners of the square and a peg driven down at the intersection.

#### MARKING-OFF LINES.

Light wire lines, No. 12 gauge, or light clothes wire, give more accurate results and answer for laying out either squares, quincunx, or rectangles. Wire lines are preferable to string, because they don't shrink or stretch. A wire line 209 feet long (a trifle over three chains) will form the side of a one-acre block. At each end fasten an iron ring two or three inches in diameter for slipping on pegs. Along this line mark out with a piece of solder the exact distance apart the vines or trees are to be set at.

Should vines be planted in a parallelogram instead of a square, two lines will be required, with the distances between the rows marked off on one of them and the distance along the rows on the other.

#### DISTANCE APART.

Before planting an orchard or a vineyard it is well to consider and decide what distance apart the trees or the vines will be set at. The following table shows the number of plants to the acre at the distances given below. It will be noticed that the septuple system allows 15 per cent. more trees to the acre and the quincunx 12 per cent. more than does square planting.

Distance apart in feet.	Square feet to each Plant.	Square.	Quincunx.	Septuple.	Distance apart in feet.	Square feet to each Plant.	Square.	Quincunx.	Septuple.
1	1	43,560	...	50,300	18	324	134	151	154
2	4	10,890	...	12,575	20	400	109	116	125
3	9	4,840	...	5,889	21	441	99	110	114
4	16	2,725	...	3,144	22	484	90	100	103
5	25	1,742	1,966	2,003	24	576	75	83	86
6	36	1,200	1,362	1,390	25	625	69	77	80
7	49	889	999	1,002	26	676	64	71	73
8	64	680	762	782	27	729	60	67	69
9	81	537	600	617	28	784	55	61	63
10	100	435	482	500	29	841	50	56	56
11	121	360	399	414	30	900	48	53	55
12	144	302	335	347	35	1,225	40	44	46
14	196	322	250	255	40	1,600	31	34	35
16	256	170	191	195					

[*Rule.*—To find the number of plants required to set an acre, multiply the two distances in feet at which the trees stand apart and divide 43560—the number of square feet in an acre—by the product; the quotient will be the number of plants required.]

A certain diversity of opinion exists regarding the best distance to plant vines and fruit-trees. In this case, as in many others, extreme views in the matter are to be avoided, and a medium course should be adopted.

If we consider *vines*, we must bear in mind that under the Australian climate, where the sum of the sun's heat is always sufficient for the complete ripening of grapes, the question of orientation is not so important as under cooler climates, and the direction to be given to the lines will be to a greater extent influenced by the shape of the field, the intensity of the hot winds if in the interior, or the sea breezes if in the coastal region. In places, also, where hailstorms sometimes occur and follow certain winds which generally come from the same quarter, the edge of the lines should be pointed towards the direction the wind blows, and not the flank, if it can be avoided.

Lines laid along the longer axis of the field rather than in the direction of its shorter width also save a considerable amount of time and exertion on the teams, which have less turning to do.

If the vineyard is to be planted on a slope with a very marked incline, the lines and ploughings should follow the contour of the slope and be laid at right angle to its fall, so as to prevent in some measure the soil being washed down the incline during heavy downpours of rain.

Whatever disposition is given to the vineyard, the land should be exclusively planted in vines, and no other crop or trees put in.

In hot and dry districts where a thick growth of foliage would rob the ground of a considerable amount of its store of moisture, wide planting is generally resorted to, while in the cooler and moister districts, where it is desirable to promote the evaporation from the ground of as much moisture as possible, and besides encourage the growth of the roots nearer to the surface, close planting is the custom.

If one takes France as an example, one notices a striking difference between the Champagne district, where there are as many as 16,000 to 18,000 vines to the acre, while the number decreases the farther South one goes, being 10,000 to 12,000 in Burgundy, 4,000 to 5,000 in the Hermitage, 2,000 in the Herault, and 1,000 in Algeria.

In Australia experience has proved that the vines do better when planted further apart, and the following distances are met with:—

SQUARE FORMATION.				RECTANGULAR FORMATION.			
			per acre.				per acre.
6ft. apart	...	...	1,200	8 x 6	...	...	908
7	„	...	889	9 x 6	...	...	806
8	„	...	680	9 x 7	...	...	692
9	„	...	537	10 x 6	...	...	726
10	„	...	435	10 x 8	...	...	545
11	„	...	360	11 x 8	...	...	495
12	„	...	302	12 x 8	...	...	454
14	„	...	222	12 x 10	...	...	363

The distances 12ft. by 12ft. and 11ft. by 10ft., are certainly excessive and an unwarrantable waste of space, the cost of periodical ploughing, scarifying, outlay on purchase of land, clearing, staking and trellising, fencing, being out of proportion with the number of vines. For currants and sultanas and strong growing vines the distances might well be 11ft. by 8ft. or 12ft. by 8ft.

In the drier districts a superficial area of ground of 64 to 100 sq. ft. should be given to the vine.

The advantages of wide planting are apparent: for a given area of ground more vines are planted to the acre; the distance between the rows allows vehicles to enter the vineyard anywhere, for carrying away grapes or for running the burner after pruning, while moreover, should at any time the vines be put on trellis, fewer posts, less wire, and fewer holes for the posts will be required per acre.

The object of reducing the number of plants per acre, as shown above, as one proceeds from the cooler districts towards the hotter or drier ones, is to equalise the development of the root system underground with the development of the aerial organs of the plant. In the South of France for instance, as well as in Algeria, where the object sought for is to promote a luxuriant growth and an abundant yield, the growth of the deeper roots must be encouraged by every means, so as to make the plant independent of droughts, and enable it to get nourishment proportionate to its yield.

So much for the distance apart vines may be planted. In the case of fruit trees, a superficial area of ground proportionate to their natural growth must be provided for.

Small trees like the mandarins, the navel orange, some dwarf apple trees, pear trees with an erect habit of growth, quince, etc., will require less space than the larger orange, apple, and pear trees or the olive tree. An orchard, however, laid out at distances varying according to the sort of fruit grown would certainly look unsightly and would moreover be difficult to cultivate; the necessity for

a uniform interval between the trees all through the orchard is therefore obvious.

Many orchards were planted at distances 15ft. to 18ft. apart, but these are decidedly too close. The average fruit-trees should not be planted at a lesser interval than 20ft., a favourite distance would be 22ft. or three trees to the chain, which would give 90 trees per acre if planted on the square, and 100 trees if planted in quin-cunx, and 103 if set according to the septuple formation; 24ft. as well as 25ft. apart are also favourite intervals for soils and localities where trees grow luxuriantly.

For the guidance of those orchardists who desire to plant certain kinds of fruit trees in blocks by themselves, the following table is given of distances found suitable for setting apart:—

Rhubarb	...	...	...	...	...	4 feet apart.
Gooseberries and Currants	...	...	...	...	...	8 "
Rock Melons	...	...	...	...	6 to 8	"
Water Melons	...	...	...	...	10	" 12 "
Grape Vines	...	...	...	...	8	" 12 "
Coffee	...	...	...	...	10	" 12 "
Guavas	...	...	...	...	12	" 18 "
Bananas and Plantains	...	...	...	...	12	" 18 "
Persimmons	...	...	...	...	18	" 22 "
Mandarins and Kumquats	...	...	...	...	18	" 22 "
Oranges and Lemons...	...	...	...	...	22	" 30 "
Plums and Prunes	...	...	...	...	22	" 25 "
Peaches and Nectarines	...	...	...	...	22	" 25 "
Pears	...	...	...	...	22	" 25 "
Large Cherries...	...	...	...	...	22	" 25 "
Apricots	...	...	...	...	22	" 30 "
Apples	...	...	...	...	22	" 30 "
Figs	...	...	...	...	22	" 40 "
Walnuts and Chestnuts	...	...	...	...	30	" 40 "
Olives	...	...	...	...	30	" 40 "

If planted in rows:—Strawberries, in double rows of 1½ft. to 2ft., with 4ft. between the double rows.

Pineapples:—In double rows 2ft. with 8ft. to 10ft. between each double row.

Raspberries:—4ft. to 8ft. between the rows.

### PLANTING.

Before planting a vineyard or an orchard, the question should have been fully discussed what special market it is intended to supply. Whether it is intended to dispose of the fruit locally or to ship overseas; to manufacture the grapes into wine or brandy; to dry into raisins, or to sell fresh as table grapes.

The natural conditions of soil, climate, and orientations should also influence the selection of the varieties. Favour the quick ripening of early sorts by planting on well exposed slopes. Again, in the case of fruit trees and vines, study the likings of each sort; putting the yellow Bellflower apple on

the lighter patches of soil, in preference to the Newtown pippin, which prefers a stronger soil. Some varieties again show greater predisposition to diseases in low moist localities, and should for that reason be planted on well drained slopes; the Cleopatra apple, which is somewhat subject to the "bitter pit" disease, is a case in point. Other questions as well require consideration when planting, for instance, such self sterile fruit as the Bartlett and other pears. Top graft a few of these or plant amongst them some varieties which will supply the pollen necessary for insuring cross fertilisation and the better setting of fruit. Pears and plums do better on a strong retentive soil than peaches and nectarines. Cherries do better on stony land on a high slope. Walnuts and chestnuts in well sheltered, shaded and moist situations. Almonds and figs in the warmest and driest parts. Oranges in rich, deep, warm soil, and well sheltered places. With reference to grape vine due attention should be paid in those places periodically visited by late frosts to the time the several varieties burst into leaf. Amongst those varieties budding late are: Carignane, Mataro, Cabernet Sauvignon. Amongst those pushing forth their buds early the Chasselas, Malbec, Grenache, Verdot, Pinot, Muscat, Black Hamburgh.

Only those varieties that have been well proved as suitable in regard to soil, climate, or the special purpose they are grown for, should be cultivated, and of these, the varieties that do best in a particular locality more largely planted.

Plant as few varieties as possible. You will find a readier market for your produce if you only keep a few "lines," to use a term employed in commercial circles. Do not have all the sorts ripening at the same time; in an early district favour more especially early sorts, and in a late one, late varieties of fruit, as you will then, with your produce meet a firm market that is not glutted with fruits of all sorts.

#### VINE-PLANTING.

Some vines, such as the Malbec, are liable to the accident of *coulure*, or of imperfect setting of the flowers, when grown on low badly drained ground, and do far better on deep, free, undulating ground. Table grapes should be planted in the richest soil in the vineyard, more especially if they can be given an extra watering from the time the berries are well set till they change colour.

Let each variety stand separately. I have seen on some of the most famous and ancient vineyards of the Medoc near Bordeaux and also in the old vineyards of Spain and of Portugal grape vines of different kinds planted indiscriminately in the same field, but that practice has gone out of favour now; and although

it is advisable to blend the grapes in the fermenting vats together, so as to insure their several component parts getting thoroughly incorporated with each other during the process of fermentation. this blending can be just as easily made in the suitable proportions without the different varieties of vines being grown indiscriminately together.

The advantages of keeping the varieties separate may thus be summed up:—

1. The vines look more uniform in the field, and a more delicate and may be desirable variety of vine is not thus exposed to be dwarfed or choked in its growth by more common and more rustic vines.
2. Varieties more liable to specific fungoid or other pests can receive appropriate dressings to ward off or keep down disease.
3. Each variety can be trained and pruned as required.
4. The picking can be done in succession by taking the varieties as they come to maturity in their proper order.

The best way of stocking a vineyard is by using *cuttings* wherever the spring and summer months are moist enough, or *rooted* plants when there is a risk of a long spell of dry weather as is the case with us. Seedlings are never raised for extensive planting, as they do not bear a crop until the fifth or sixth year at least, and besides, like most other intensely cultivated plants, vines sprung from seeds always show a tendency to sport and vary.

The best cuttings are obtained from the middle portion of the bearing canes of the previous season, the wood being well summered, keeping well, and striking root and budding readily. The shorter the cutting the stronger the vine.

Very tender cuttings are those that grow quickest: but they are also very apt to perish, on account of the pithy condition of the wood, and are not to be relied on in dry seasons and open field cultivation. It often happens that the resulting plants are, besides, of a weak constitution. On the other hand, cuttings with hard and tough wood do not strike root so easily, and show a tendency to grow more wood than fruit. Whenever, therefore, it is possible, the middle part of a cane, of healthy summered wood, should be chosen from prolific plants.

Cuttings 10 inches to 14 inches long are the best for planting in this country, and only one of the buds should show above ground and not two or three as are often left. The complete covering of the cutting and of the terminal bud under some sand or loose soil, delays the growth of the leaves, which are the natural organs of evaporation of the plant, whilst the young rootlings take hold of the ground and supply food for the requirements of the young

vine. If more than one bud be too much exposed to air and light, leaf growth out of proportion with root growth exhausts the cutting which dies as the ground gets drier.

Short-jointed cuttings are preferable, and they should not be taken from a vine attacked by any fungoid pest, such as *anthracnose* or *oidium*, etc., as they are, as a rule, less vigorous, and there is always the risk of propagating the disease and infecting the young vineyard with the disease.

The fresher cut, the better will cuttings strike. It is not always possible though to get cuttings freshly pruned as they may have to be procured from distant parts.

When sending them on a lengthy journey it is well to tie them into bundles of 100 to 200 each, and put around them some straw very slightly moistened with water, and wrapped up in more dry straw and then put in cradle cases or in gunny bags, which, on arrival, should be opened, the bundles taken out and placed in an open furrow in some well drained place of the vineyard.

The best time for planting is early in the spring, in the moister districts, as at that time the surface soil has been sufficiently penetrated by the warmth of the atmosphere to favour the growth of the tender rootlets. In drier places, where the hot weather comes early and the rainfall gets scarce as the spring draws on, the planting should be done even earlier.

Cuttings should only be planted under the best conditions, as failure to strike means added cost in replanting the season after and a longer time before the vineyard becomes productive. Should any doubt be entertained as to the striking capabilities of the cuttings—and some varieties, such as the brown Muscat, for instance, are very hard to strike—the bundles are often taken from the trench where they have been lying, and placed a few inches deep into water. After three or four days, the bark gets sappy, and small wart-like swellings, covered with a little gummy substance, show at the butt. The cuttings should then be planted without delay, as the rootlets of the plant soon break out and might possibly be damaged when handled.

A single eye cutting produces a more vigorous root system than a cutting 10 to 12 inches long, and a medium size one will, in a similar manner, strike a better constituted root system than long cuttings 18 to 20 inches long, in which case a distinct system of roots will come out in layers out of every joint, and will not be so strong and vigorous as if they issued from the same joint as near the surface as possible, and with a tendency of striking deeply into the soil, in a downward direction.

To assist these single eye cuttings striking, they are set in the spring in moist sand under glass frames, and when the shoots com-



mence to push upwards, fed by the tender roots in the sand, they are gradually hardened by more direct exposure to the air and are finally transplanted, when they make sturdy plants.

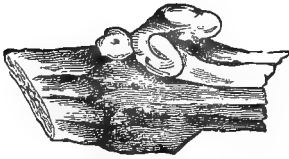

Single Eye Cuttings.

It is often necessary to keep the vine-cuttings a month or two before they can be planted out; they should in that case be put temporarily in a trench dug in well drained and moist soil and banked up with earth where they will keep dormant; at planting time only a sufficient number of cuttings for the day's requirements should be taken out.

Rooted vines, whenever obtainable at a reasonable price, are much more certain to strike root and grow. In many parts of the Eastern States, where the spring and summer months are moist, cuttings are generally planted in preference, but in this State rooted vines are more reliable. Although the cost of rooted plants is five or six times as much as that of cuttings, the certainty and the more uniform growth and early cropping are in favour of rooted vines as compared with cuttings.

A small nursery should be planted to provide rooted vines for filling up blanks occurring after the first season's planting. Few cuttings probably strike better than vine-cuttings, and those can be got at pruning time for little over the cost of trimming.

For stocking a nursery, shorter cuttings than those generally used for planting out in the open field are preferable; they develop a better root system, and are less liable to dry up after having made a fictitious growth, as more care and attention can be given them, and moisture in the ground can be better maintained by cultivation or by occasional waterings, mulchings, etc.

In the nursery lines the cuttings can be put in at a distance of 6 to 10 inches, with an interval of 18 to 24 inches between the rows. The plants should be lifted up with much care so as to injure the tender roots as little as possible, and these should be carried to the field either wrapped up in a wet bag and put in a basket or placed in a bucket of water.

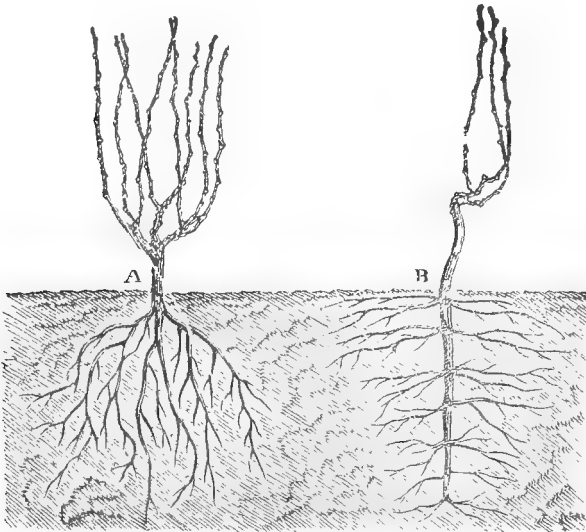

A. Strong vine from short cutting, showing vigorous root system, growing from the same joint. B. Weaker vine from long cutting showing disposition of roots.—(Fœx.)

The holes having been previously dug, the bruised roots are trimmed with a sharp knife or a secateur, and the rooted vines planted in the way fruit trees are generally set; all shoots but one are then cut off, and on this two good buds alone are left.

Unlike cuttings which are planted very early in the spring, rooted vines may be put in the ground at any time in the winter; they then establish themselves and take a good hold in the ground, and make a vigorous growth as soon as the spring sets in.

Sandy loams do not show a tendency to crack in dry and hot weather; but in heavy soils the ground, contracting in the summer, very often leaves an open space round the cutting, especially if it has been put in vertically, without having been slightly bent. In that case, and unless some sand can conveniently be put round the cutting, the hole should be well trampled down, up to about two-

thirds of the length of the cutting or rooted plant, and the remaining third banked up with the more friable and well-pulverised soil, which is left loose on the surface.

A handful of bone-dust and wood ashes, kainit, or better still either sulphate or muriate of potash, worked with the earth round the plant will in many places provide nutriment for the young root-lets, and insure the rapid growth.

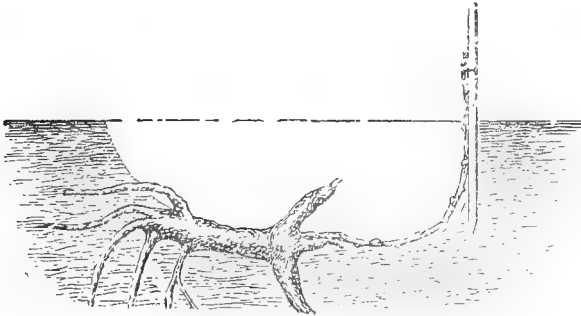

Layering an old vine stump.

#### TREE PLANTING.

The ground is marked off by means of pegs or light stakes, so that whichever way the rows are looked at they all seem to be in perfectly straight lines; then the holes are dug.

The holes for fruit trees should be wide enough to permit of the spreading of the roots; the wider the better. In heavy, retentive soil they should not be deeper than the land has been ploughed, as otherwise such holes get full of stagnant water, and would hold it like a basin; many a fruit tree has been killed through the roots thus decaying instead of growing in a healthy condition.

Before the holes are dug and in order to insure that the trees will occupy the exact spot the stakes were in, a simple contrivance known as the "tree-setter" is of great use.

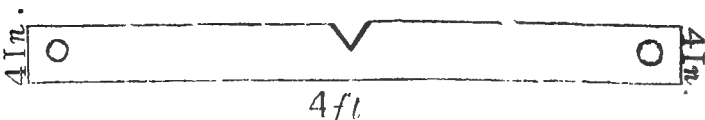

It consists of a light piece of board 1 inch thick, 4 inches wide, and 4 to 5 feet long. Cut a V shape notch in the centre and either

bore a hole  $1\frac{1}{2}$  inch in diameter at 3 inches from each end; or, instead of the holes, cut notches at each end of the board.

To use the "tree-setter," the V shaped notch is put against the stake, which marks the spot the tree is to occupy. Through the hole at each end, or in the notches, as the case may be, drive into the ground pegs 1 to  $1\frac{1}{4}$  inch in diameter and 12 to 15 inches long that will easily pass through the holes. This having been done, remove the central stake in the V notch, lift the board over the two terminal pegs, which are left in the ground, and dig the hole. When planting, replace the "tree-setter" over these two pegs, and place the stem so that it will fit into the V; it will then occupy exactly the same spot the stake occupied when the ground was laid out.

The hole should be three feet square, convex in the centre, or of the shape of an inverted saucer. This is done by heaping up some loose surface soil, so that when the tree is planted its base stands a little higher than the roots, which spread out evenly round, radiating outwards with a slight dip downwards.

Whenever patches of hard ironstone conglomerate, such as are met with at places on the Darling Range, or of impervious peaty or calcareous hardpan, such as exist sometimes round ti-tree swamps in the coastal zone, occur, a few plugs of gelignite exploded in the ground will leave numerous crevices which will promote the drainage of the land and permit the roots of the plants to penetrate through the pan and gain access to the subsoil underneath.

*Selecting the trees* from the nursery requires some discrimination. The varieties to be planted having been decided upon, place the order with a good and reliable nurseryman, preferably a local one with a reputation to keep up. Sixpence more on the price of a tree, when compared with the fruit pedler's quotations, may have to be paid, but it will be money well invested.

When buying trees it is well to stipulate that the stems should be smooth, the roots not too much hacked about; that the trees, if peaches, should be on peach stock, except when planted on heavy clay or in damp places, when they might be on plums; apples on northern spy, citrus trees on bitter orange or on pomelo, to guard against collar rot. It is well to require some guarantee that the trees are free from fungi and injurious insects, and more particularly some of the worst scale insects.

Large quantities of deciduous nursery stock are received from oversea. These carry best when packed dry in bundles. If wet and placed in the holds of ships they sometimes heat and after a few days the bark and buds turn black. Citrus trees are packed with

the roots in earth and both tied in hessian, or they are placed in shallow cases with damp sawdust round the roots and a hessian cover, and they are kept in a cool and ventilated place.

On arrival, each tree should be examined for any indication of root galls; scale insects, black aphid, borers, or fungoid disease, and unless it is accompanied with a certificate of disinfection at the nursery, it should be treated by dipping in warm whale-oil soap suds (1lb. of whale-oil to 3 gallons of water), or in kerosene emulsion for a couple of minutes in the case of insect pests, or in Bordeaux mixture in the case of fungoid disease.

The young trees are then heeled in without delay. For that purpose a trench is dug in moist but well-drained soil and the trees placed in it, slanting towards the same direction, and loose, well-pulverised earth banked up round the roots and every part of the stems; the trees will stand in that state until required for planting.

It happens that they are sometimes barkbound, showing a leathery, shrivelled bark. In that case they should be thoroughly drenched first and then stratified or covered up with moist loose earth or sand, root, stem and branches, for a couple of days or so, when, unless too far gone, they assume their healthy look again.

The best time for planting all sorts of trees is when the sap is down, and after the autumn and winter rains have penetrated the soil to a good depth. That time in this State will be from May till August. Citrus trees are set out after the first autumn rain or, better still, late in the winter in August. Do not plant while the earth is water-logged, as its handling at that time would puddle it, and it would cake round the roots of the tree and subsequently crack and let in the hot air round the tender roots.

When lifting from the trench, make, with a sharp pruning knife, a clean cut of any bruised root, and taking the tree to the hole dug on the spot it is going to occupy, with a few shovelful of earth raise the bottom of the hole so that the collar or ground line on the stem is flush with the surface ground of the orchard. The tendency until a few years ago has been to plant trees, more especially in this State, much too deeply, with the idea that during our dry summers, the roots should be put as deep down into the ground as possible so as to insure a proper amount of moisture being always within their reach. Collar rot, the rotting of the roots, stunted growth, are all due to this defective method of planting, and to this cause mainly must be attributed the loss of so many fruit-trees planted in this country. Deep planting, insufficient pruning, deficient cultivation, neglect of pests, may be said to be at the bottom of the failure of a great many fruit trees in this State.

As a general rule, if the soil in which the tree is planted is the same as the one from which it was taken, the tree should be set the same depth as it was before it was removed from the nursery row. If the soil is heavier, the tree should be set a trifle shallower, if lighter it should be planted a shade deeper.

Those with little experience of planting trees often plant too deeply and set the tree into the ground without spreading the roots as shown in the second figure; they at times also place stable manure right over the roots. Such trees generally get stunted and

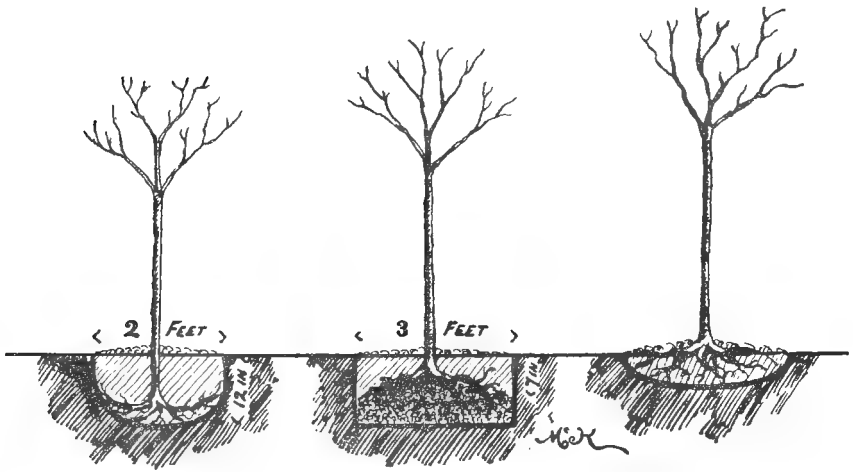

Tree too deeply planted.

Tree rightly planted.

Tree set too shallow.

hide-bound and only recover when lifted up to the proper level. Trees, on the other hand, planted too shallow are easily blown down by windstorms, and their exposed roots dry when exposed to the dry summer sun.

#### HOW TO MANURE WHEN PLANTING.

If the trees are planted late in the season, when dry weather sets in, it is advisable to pour a bucketful of water around the stem to settle the earth well on the roots. Mulch the ground about the newly planted trees with a light coating of stable manure or of straw.

Fertilisers are sometimes used at the time of planting for giving a good start to the trees, but avoid putting farmyard manure under the roots of the plant, as it would in many cases attract insects and favour the growth of parasitic moulds that would be injurious to the tree. Of chemical fertilisers a couple of handfuls of phosphates and potash manures mixed will in many cases prove of great value, well worked with the earth round the roots. Whenever farmyard manure is used, it should be in the form of a mulching on the top of the soil, as its beneficial effect will then be twofold: the plant food it contains will be washed from the surface down to where the roots are established by the winter rains, and it will act as a screen which will be of benefit to the plant by preventing the evaporation from the soil, and by smothering any weeds that might happen to grow round the trees. When the planting is done on freshly-cleared ground, sour and heavy, lime is an excellent preparation. The places where the trees are going having been marked, 6lb. to 7lb. of lime is spread around the stakes; the holes are subsequently dug and the trees put in. This will correct the sourness and the stiffness of the soil and induce a healthy growth. Some open up the tree-hole some time before planting, but if the ground is at all stiff and heavy, the liming as described above is preferable. Unless this dressing is applied it often happens that the sides and bottom of the holes are coated with a viscous glaze which prevents the tender roots reaching to the soil beyond.

After all the precautions have been taken for insuring the proper planting of the right sort of trees, all the efforts of the beginner are often frustrated by neglect of another important detail. The newly planted tree must be cut back, or shortened in, or else its growth will be checked, and it will not uncommonly perish. So long as it was in the nursery, the root system of the young plant was unimpaired, absorbing from the soil all the nutriment the branches required, but when taken up, no matter how carefully, many of the fine feeding rootlets are torn and bruised, the feeding capacity of the tree is no longer in keeping with the amount of shoots it carries, and unless the excess of these is cut back and the balance re-established between the feeding and the breathing and evaporating organs of the plant, it will fail to thrive. The bark will become leathery and tight, the sap will heat and ferment under the action of the sun, and the tree will fall an easy victim to the attacks of borers and other noxious insects.

#### HOW TO TIE A TREE.

A strap made of cloth or twine is passed round tree and stake in such a way that when properly fixed it forms the figure "8" around the tree and support to which it is firmly tied. This method avoids friction and chafing of the bark, and a curved stem can gradually be straightened.

As soon as planting has been done it is advisable to draw a plan of the orchard on which is indicated the respective position of each tree, with numbers which will refer to an index recording the name of the trees or rows of trees planted. Labels may be lost or torn away, but with such a plan no possible mistake can happen at any time regarding the correct name of any tree grown in the orchard.

#### LABELS FOR FRUIT-TREES.

More especially in the home garden a variety of trees is often planted, and as it would be inconvenient to keep continually referring to the map of the ground to ascertain the name of trees, it is advisable to attach labels to them.

Of these several kinds are sold by seedsmen and florists. If the surface of the zinc label is greasy, kerosene or petrol rubbed over it will cause the lead pencil to bite, the writing remaining long unaltered by the action of the air, while the metal itself may become oxidised. The zinc labels at first look very neat, but unless they are punched with letters or definite marks the writing disappears after a few seasons.

Cheap and convenient labels are ordinary painted pine labels,  $1\frac{1}{2}$  inches wide and 6 inches long. A piece of galvanised wire is fastened to them at one end. The name of the tree or plant is written with a soft pencil upon the label, which is then dipped in white of lead well thinned with oil. The paint at first obscures the writing, but on drying the lettering comes out again more distinctly, and remains visible for quite a long time.

#### SUMMER CULTIVATION

is in a hot and dry climate even more important to the well being of fruit-trees as is pruning itself. In Europe orchard land is generally grassed. In Australia, where climatic conditions are totally different, the old methods have likewise been tried and have failed. Vines and fruit-trees, to be profitable in this climate, must not only be kept scrupulously clean, but the surface of the soil must be stirred at frequent intervals.

Fruit land should not merely be kept clean of weeds, but it should be thoroughly tilled: clean cultivation is not all that summer cultivation implies; it is only part of it. Summer cultivation acts besides in a variety of other ways; it maintains the soil in a condition favourable to the growth of the roots of the plants; it retains moisture in the ground, and it also leaves it in the most favourable condition for absorbing more moisture from the atmosphere; by opening up the soil it promotes its sweetening through the action of the atmosphere on the particles of the soil.



Moisture brought to the land by rain gradually sinks into the ground, the surplus finding its way into soaks, swamps, or streams. A notable portion of this water, on the other hand, has a tendency to rise again toward the surface under the influence of that same capillary attraction which causes damp to rise on a brick wall built on moist ground, or which is noticeable on stakes driven into the ground, or on old tree trunks. This ascending current of moisture goes on more or less actively, evaporating on the surface on which play the sun and the wind, until after a long period of dry weather all the moisture has been sucked up from some depth below, and the ground gets as "dry as a brick."

By surface cultivation this wasteful escape of moisture from the ground is checked; the capillary attraction is, for a time, destroyed close to the surface, although it goes on without check a little deeper down; water continues, without sensible interruption, to be drawn up all the same from the subsoil, but, owing to the fact that it is no longer sucked up to the surface, where it would evaporate under the agency of sun-heat and wind, it accumulates in the layer of soil in which the roots feed, moistening it, keeping it cool, and dissolving the fertilising elements contained in the soil, thus favouring root-growth and, in proper time, fruit production. It is important, to achieve this end, that the surface soil should be as well pulverised as possible, and not ripped up into coarse clods. This would allow of the penetration into the deeper layers of the soil of too much heat and of the desiccating wind which, by evaporating what amount of moisture is continuously rising under the action of capillary force, would frustrate the object of the grower to keep in the ground the moisture necessary to dissolve plant food and prepare it for the roots, which can only utilise it when presented in the liquid form. A well cultivated field is also better prepared to absorb and imbibe whatever amount of water comes down in rainy weather, instead of allowing it to run to waste on a hardened crust into the drains or the gullies which carry it away to the rivers. Loose earth acts as a sponge which gets permeated during the night by the damp air, condenses and retains its moisture, and freshens up the crop.

The thorough cultivation of the soil answers, moreover, another object.

Thorough cultivation checks the growth of a meshwork of tender rootlets close up to the surface, and enables the deeper seated roots to hold their own and carry on their functions under favourable conditions. The cultivation should be so regulated that the principal roots of the plant are not injured and torn off; it should be deeper in hot and dry localities where surface roots are more liable to get scorched and desiccated in times of drought, than in moister and cooler districts. A maximum of six inches in dry and

hot places, and four to five inches in moister localities, is deep enough for all purposes. Unless this cultivation is every year carried out, the surface-feeding rootlets will soon assume upon themselves the duty of foraging for the maintenance of the plant, and thus finally cause the gradual withering up and atrophy of the deeper-seated roots. The result of subsequent cultivation, followed up by intense summer heat, may well be imagined. The superficial rootlets having been destroyed by the field implements, it might happen that the deeper ones would not prove equal to the tax suddenly thrown upon them after having become inactive, and the result on the plant would soon make itself only too apparent.

To sum up, the object of summer cultivation consist in destroying the thirsty and hungry weeds; in intercepting the upward motion of moisture from the subsoil, and storing it up in the feeding layer of earth round the roots of plants; in enabling the soil to soak in and condense more water; in sweetening it by promoting the ready access of the atmospheric air; in hindering and preventing the invasion and propagation of noxious insects by exposing them to the action of a roasting sun-heat or to the attacks of insectivorous birds and other natural enemies.

#### FIELD IMPLEMENTS USED IN CULTIVATION.

Three sets of horse implements are necessary for the thorough cultivation of vine or fruit land:—

- A suitable plough,
- A scarifier,
- A set of harrows,

without mentioning the hand hoes, pick, digging forks, and minor tools and appliances in use for working the soil close up to the tree.

A considerable variety of implements are offered by the trade which claim to do the work they are expected to do in the best style and at the cheapest cost. The ingenuity of modern makers has been considerably taxed of late by the desire to excel their rivals, and the result, so far as design and workmanship are concerned, has attained to a high state of perfection when compared with the implements used for similar purposes only a few years ago.

Where some levelling is desirable to secure an even surface, an earth scoop after the surface has been “scruffed” up with the plough, is of great assistance. Another suitable implement for this work is a “buck scraper” made of a solid wooden beam, two

inches by 12 inches, cut level with the adze on one side and iron-shod to scrape the earth.

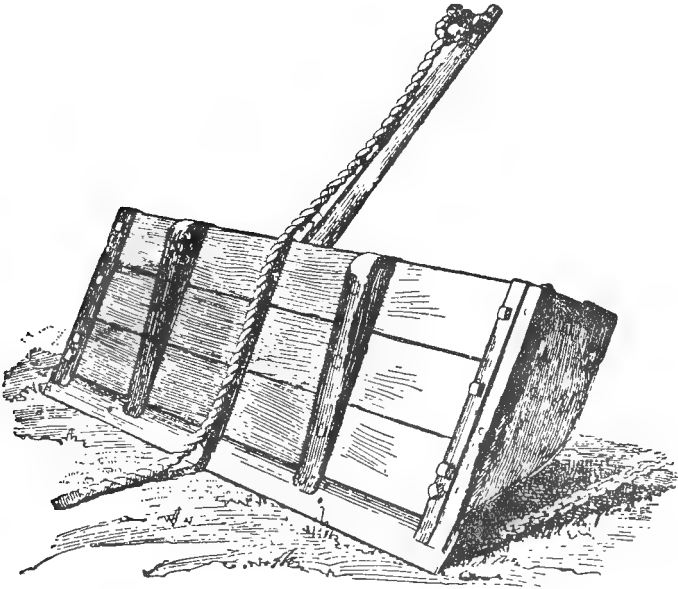

Buck scraper tipping over its load.

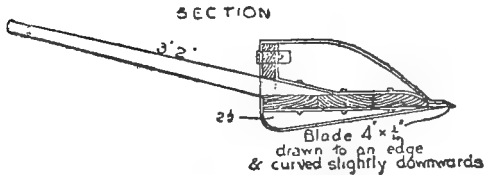

Sectional view of a buck scraper.

A guiding handle bolted to the scraper is used for holding the board at an angle when paring a slice of the uneven ground. One length of chain at each end of the scraper and looped to the whipple-tree complete the implement.

Another serviceable land leveller is thus described in the *Settlers' Guide* issued by this Department:—"The leveller may be made on the farm, all the aid it will be necessary to invoke being

that of the blacksmith to make the iron nose and even this is not an absolute necessity, as our hardwoods will stand a good deal of friction before wearing away.

To make the leveller, take two hardwood planks about 12 feet in length, two inches thick, and eight inches wide. Cut down one edge with a drawing knife, plane, or adze, so that it will be about half an inch on the edge. Put the boards together in V shape, with the flaring edges at the bottom inside and resting on the ground. Take an eight-foot board, trimmed down the same, but two inches narrower. Mortise and bolt the ends into the side boards about two feet from the ends. Put two bolts through where the side pieces are joined to make the front of the leveller. Bolt a hook on top so that the whipple-trees may be attached. Nail an eight-inch board across near the centre. When you want to cut down a ridge, ride upon the board, drive the horses on one side, and swing your weight so as to cut into the soil. If you wish to fill up dead furrows or ditches, drive along one side and throw the weight of the body where the soil is to be moved from, and thereby gauge the filling of the hole.

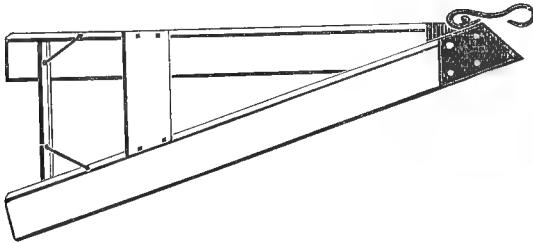

Serviceable Land Leveller.

Every year almost witnesses the production of implements possessing special merit; among those in favour at present are the Digging Plough, the Disc Plough, the Spading, the Acme, the Disc, and the Spring-tooth Harrows, as well as the old Drag or Zig-zag Harrow, the Planet Junior Horse Hoe.

The annual cultivation of the soil may be said to begin in the winter time, when one or two ploughings are done according as the soil is lighter or heavier, and the work of cultivation effected more thoroughly.

At least one of these winter ploughings should be deep, and the plough should be set in the middle of the rows of trees or vines to a depth of six to seven inches. When finishing off, a lighter plough may be used with advantage, or the depth of the furrow reduced to three or four inches.

Our orchardists, as a rule, fail to pay sufficient attention to this deep cultivation, with the result that in the height of a dry summer the numerous feeders which have taken possession of the soil a few inches under the surface of the ground wither and dry up, the plant as a consequence showing signs of distress. Deeper ploughing, whilst checking the growth of these superficial roots, offers an encouragement to the growth of the deeper-seated ones. When an orchard or a vineyard has long been ploughed only three to four inches deep, it would be manifestly injurious to deepen the cultivation all at once to six and seven inches, as a considerable shock would result to the plant by tearing the superficial roots; but in a dry and warm summer, such as our Western Australian summer, due attention should be paid to the gradual deepening of winter cultivation.

Various sorts of ploughs are made for the purpose; the one horse Vine Ploughs of the type specially constructed by Ransome, Sims, and Jefferies, of Norfolk; Howard, of Bedford, and other good makers are made for vineyard work, and answer splendidly for turning the last furrow or two, close up to the trees in the orchard, without bruising the bark. They are light, with a short beam, and the body thrown six inches off the centre on the mould-board side; they do not turn a furrow so deeply as the ordinary plough, and the ploughman has complete command over his implement, being able to throw it out of the furrow instantly should it happen to come into contact with a vine stump.

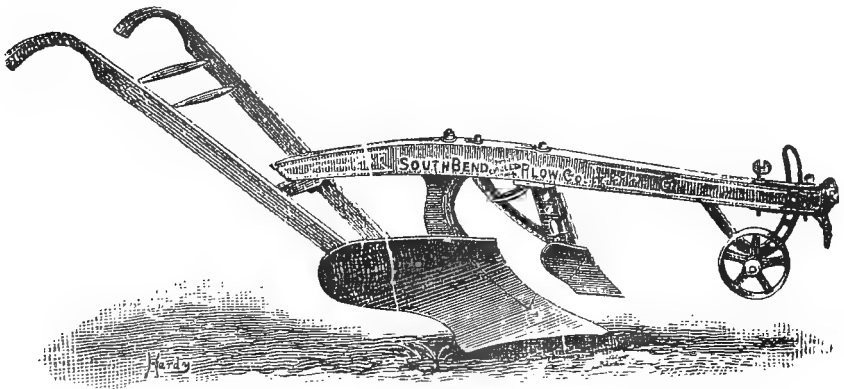

Digging Plough.

A better plough still is the Digging Plough, which, in breaking up and pulverising the ground, approaches nearer the spade and

the fork than any in the class of work it turns out. The shifting principle of the handles and the adjustable head-rack make it possible to plough the ground right up to the butt of the trees when ploughing either on or off. It also possesses over the long mould-board wrought-iron ploughs marked advantages. It is easier in draught and lighter in weight; it is cheaper in price, and the spare parts can easily be obtained from the agent, and replaced without trouble whatever by any ploughman. An "Oliver Chilled, No. 40," costing £4, with a team of two to three horses, will turn a furrow nine inches deep and 16 inches in width, and only weigh 130lbs., as against 170lbs. to 180lbs. of the wrought-iron plough, cutting a furrow six inches deep and only nine inches in width. Patent shares with reversible points may be fitted on these Digging Ploughs.

Whilst the long mould-board plough half turns the furrows into long symmetrical parallel ribbons, the Digging Plough turns and pulverises the ground thoroughly, leaving the surface—especially if the land be free and light—comparatively smooth and better exposed to the weathering action of frost, sun, air, and rain. It is made of cast-iron or steel, the steel ploughs being durable and light on draught. The "double furrow" plough is used in the larger orchards, and is also fitted with shifting handles and head-rack, which enable it to plough fairly close up to the trees, but the single furrow is generally used to complete the work. The Disc Plough has of late years come out as a capital implement for the strong, heavy soils, which are worked with difficulty with the mould-board plough, unless the land happens to be put in the right state for ploughing. The discs require no "laying," is not clogged with weeds, which it cuts through, and lasts much longer than shares.

When only one ploughing is done, the earth should be thrown away from the trees or vines; while when two ploughings are given, the first is generally away from the rows and the second to the vines or trees. In the first case, it is necessary to afterwards level the surface of the ground by means of a scarifier.

Whenever weeds are high in the field, as sometimes occurs on neglected places, or where a green cover crop of peas or some kind of leguminous plants has been grown for the purpose of being ploughed in and enrich the lighter soils, a short-looped heavy drag chain attached to the beam of the plough will bend down the grass and facilitate the operation of ploughing.

In order to break up the wall or strip of hard land in the line of the trees, the two ploughings are done crossways; and whenever the slope is not too great and the soil too heavy, a gang plough turning two furrows at the one operation will get through the work quicker, one man with a pair of horses doing nearly as much work

again as if the single-furrow plough only was used. There is little need to say that the horses worked in the orchard and vineyard should be steady and well broken in, the man careful, and the whipple-tree as short as possible, so as to guard against any possibility of bruising the trees.

#### THE SPIDER HARNESS.

Fruit trees often suffer considerable damage by having their branches broken and portions of the bark of their stems removed by the swingle-tree and long trace chains still used in some orchards. Particularly is this so when the work of cultivation is being performed by incompetent or careless drivers. The chance of injury to the trees may be reduced by employing orchard harness of the type shown in the plate. This harness is comparatively light, and the steel tube forming the bow is held up by the hip straps, and the traces being of leather, there is no rough surface to come into contact with the trees. As the draught is adjustable from straight behind the horse, when ploughing on or off, there is no liability of the bow chafing the horse's legs.

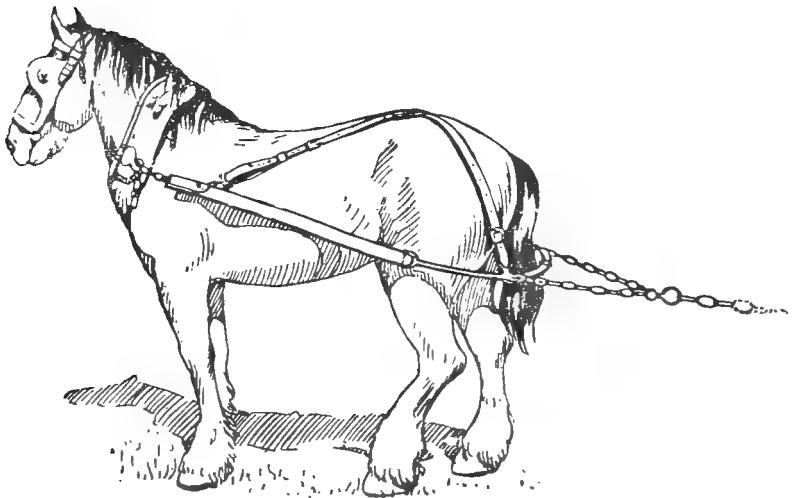

Modern Orchard Harness.

The same result can be achieved without incurring the cost of the special orchard harness by having the ordinary trace chains and a short whipple-tree. The chains are brought together to form

a triangle as shown in the figure, and are tied into a double knot. The loose end of one of the chains is then coiled round the knot to keep out of the way, while the loose end of the other chain is hooked on singly to the implement.

#### DISTANCE TRAVELLED IN PLOUGHING.

An observer who has given some attention to this subject contributes the following interesting notes. The first column of figures gives the width of the furrow in inches, and the second column the distance travelled in ploughing one acre in miles:—

Furrow Width.				Length.	
Inches.				Miles.	
7	..	..	..	..	14½
8	..	..	..	..	12½
9	..	..	..	..	11
10	..	..	..	..	9 8/10
11	..	..	..	..	9
12	..	..	..	..	8¼
13	..	..	..	..	7½
14	..	..	..	..	7
15	..	..	..	..	6½
16	..	..	..	..	6 1/6
17	..	..	..	..	5¾
18	..	..	..	..	5½
19	..	..	..	..	5¼
20	..	..	..	..	4 8/10

These figures are thus checked. An acre is 10 square chains, so that a piece of land five chains long and two chains wide will be exactly one acre. If this land is ploughed lengthwise every furrow will be five chains long. If we take the width of the furrow as one link, which is 7.92 inches, it will require 200 furrows to complete the strip, so that the horses, in addition to turning round at the headlands, will have to travel 1,000 chains, and as there are 80 chains in a mile the distance will be 12½ miles. If we take a field of 80 chains long and 30 chains wide—that is, an area of 240 acres, and if it be ploughed lengthwise, each furrow will be exactly a mile long. Supposing a man were ploughing this with a three-furrow plough, cutting approximately 24in., this would be equivalent to a fraction over three links. In the 30 chains there are 3,000 links, so that it would require 500 trips up and 500 trips down to turn over the whole of the ground. This would be equivalent to 1,000 miles which the team would have to travel in ploughing the field. Supposing a ploughman averaged three acres a day it would take him 80 days to do the 240 acres; and if we divide the 1,000 miles by 80 days, we would again get the figures of 12½ miles per day.



However careful the ploughing and scarifying is done, it is not always possible, nor advisable, to come nearer than a foot or 18 inches to the tree, round which the ground has consequently to be dug and turned by hand labour. For this work the *forked spade* is the most convenient tool to use. It has five stout cast-steel tines about an inch wide and somewhat pointed. For loosening the earth about the roots of the trees and turning in manures, etc., it is much less liable to cut and injure the roots than the spade.

#### THE SYRACUSE STRIP-DIGGER.

Is a labour saver in the culture of grapes and berries. The hoe is easily guided in and out around the posts and vines, by the disc caster wheel to which the handle is attached. The horse is hitched to one side of the pole, with plenty of room for the plough to work under the vines or bushes. By changing the position of the blade, the soil can be thrown towards or away from the vines. The cultivator attachment may be worked with the horse hoe.

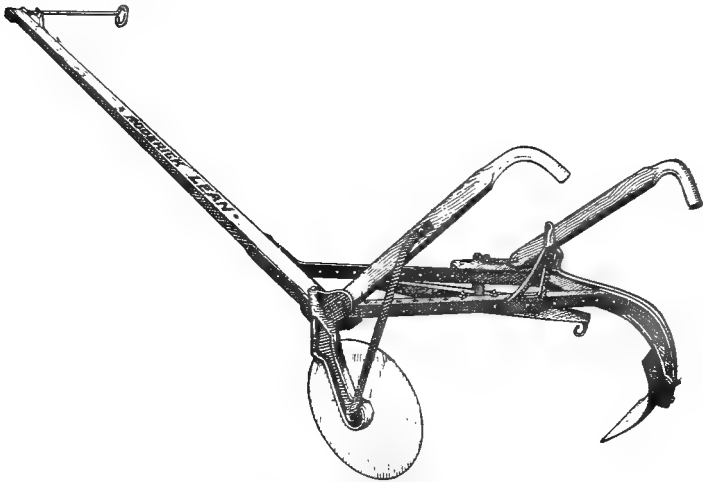

The Syracuse Strip-digger.

#### THE SCARIFIER OR CULTIVATOR.

These implements have been so much improved of late years that they may be said to be as efficient, and in some cases even more so, than the plough, and they are generally used in conjunction with the plough in order to cut and root up weeds, and to secure a fine tilth.

The more modern scarifiers are of a lighter draught, and the tines are so arranged that they cover and break up the track of the wheels.

In Western Australia the State Implement Works at Rocky Bay is manufacturing orchard and vineyard cultivators light of

draught and strong and simple of construction at prices which compare favourably with that of the best implements of the kind imported.

Amongst those more especially adapted for orchard and vineyard work are the Spring-tooth Harrows made by the Canadian firm of Massey-Harris and the United States firm, Osborne & Co.

It is shown in the illustration as running on the skid, but by the handle and rack adjustments the teeth may be lowered to work at the desired depth.

#### THE PLANET JUNIOR HORSE HOE,

of which there are two sizes, the five and the nine tooth implement, combines several of the essentials of a good agricultural implement; they are moderate in price, light, strong, are sold with or without interchangeable pieces, do very good work, and are particularly suitable for market gardens, corn or potato cultivation, and small vineyards. The plates which, like the rest of the implements, are made of the best steel, are also secured to the standard by bolts; they are reversible, and can thus be used until worn out.

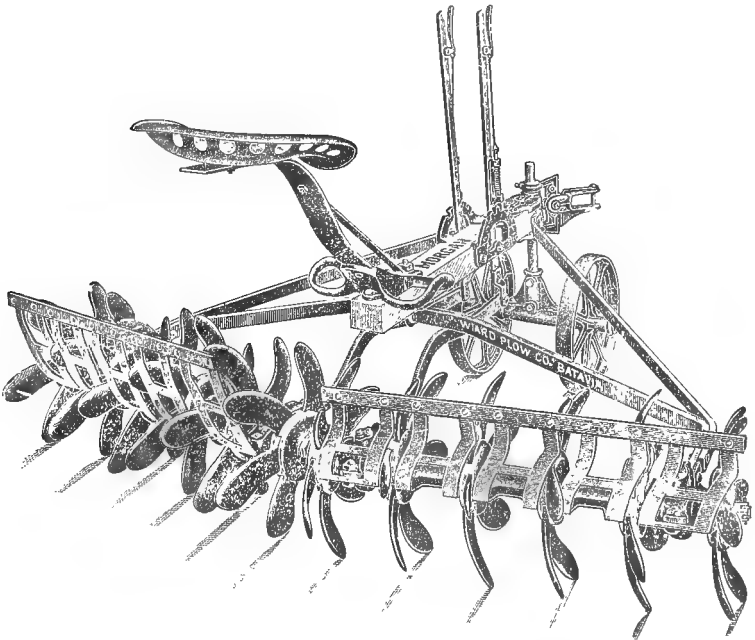

The Spading Harrow.

Among the harrows that have of recent years gained favour with the vine and fruit growers, can be mentioned

#### THE SPADING HARROW.

made by D. S. Morgan and Co., an American rotary harrow, made all of steel and iron, except the pole and seat support.

To give an idea of the construction of this implement, it may be said that the action of each cutter is similar to that of a spade, lifting and turning the soil from a depth of four to six inches and doing most perfect work. The spades are of forged steel, made S shaped, and put together in sets of three each, forming six points or spades. Thus in a six feet harrow of 12 sets of spades there are 72 small spades cutting and turning the soil. The gangs are so arranged that they freely float over the ground, thus enabling the most uneven ground to be thoroughly harrowed and left level, without any furrows or ridges. The draft is from the under side of the pole, and the seat is set well to the rear, making a perfect balance, and relieving the horses of any neck weight. For very mellow soil, or when going over roads, the rider should not ride, so as to lighten the machine. All parts are interchangeable; breakages, however, are quite uncommon, and each piece can, if necessary, be replaced or repaired in a few minutes. A cleaner, which is very effective in sticky soils, or long stubble and weeds, is supplied with the implement.

The late Mr. L. Lindley Cowen, who used this spader at Guildford on rough, fallow ground, hard, compact stubble land, and cultivated vine land as well, thus described the work it performs:—

“We have had one of the six-foot spaders at work during the past four years and find it lighter in draught than I anticipated, and far superior in the work it does to the older-fashioned disc and cutaway. I tried it in a heavy clay fallow, in a stubble, and on light loam, in every case with excellent results. A smart team of two horses would do from eight to 10 acres a day. For orchard and vineyard work it is admirably suited, as well as for general farm work. It appears to be strong, well made, and not likely to get easily out of order.”

Several sizes are made, but the one horse three feet width, two horses six feet width, are now generally used; a new type machine has a forecarriage on wheels instead of the pole, which is severe on the horse's neck.

#### THE CUTAWAY HARROW.

finds great favour for loosening, crumbling, and lightening the soil. It is an improvement on the Disc Harrow, and consists of gangs of discs with four triangular notches cut out so that each disc has the appearance of four spades with their tops welded together; there are four to six discs on each of the two bars, which work in an universal joint, and can be set at any desired angle, and rise and fall with the irregularities of the land. The steel discs are dished or concave in shape, and as they revolve they lift and to some extent invert the soil to the depth they penetrate. The seat is placed over the back of the pole, which is balanced by the

weight of the driver. This implement does excellent work in eradicating weeds and cultivating the soil thoroughly.

#### THE DISC CULTIVATORS.

have now become quite a favourite. They are made of different sizes. For orchard and vineyard work the one horse disc cultivators have two gangs of four discs each and the two horse discs two gangs of five discs each. They have a forecarriage, carried on wheels, which is operated by means of a lever from the riding seat and can thus turn on narrow headlands in a smaller circle than the shaft or pole cultivators. They are very suitable for chopping up and turning in long weeds and trefoil and also cover crops of field peas in the spring time. They cut through and pulverise heavy clods of clay which would hardly be touched by other implements and are particularly suitable for clay soil which clogs the mouldboard of share ploughs or fail to be pulverised by others. A very good two horse disc cultivator is manufactured by the State Implement Works at Rocky Bay and sold for £15 each. The discs are British made and the framework made in Western Australia. The cost at present is £15 but will very likely come down when discs and steel become cheaper.

#### THE ACME HARROW.

is also a very good implement (cost, two-horse £6) for reducing the surface of the field to a fine tilth.

It is also a riding harrow, and consists of sets of two curved blades or coulters made of spring steel, one of which performs a paring action, and the other one a crushing action, the implement performing the three operations of clod-crushing, levelling, and harrowing at one time. It is of light draught, simple and durable; unlike the spading harrow, it does not turn under the soil like a plough. In very mellow soil, and in covering in seed in such soil, the driver should not ride.

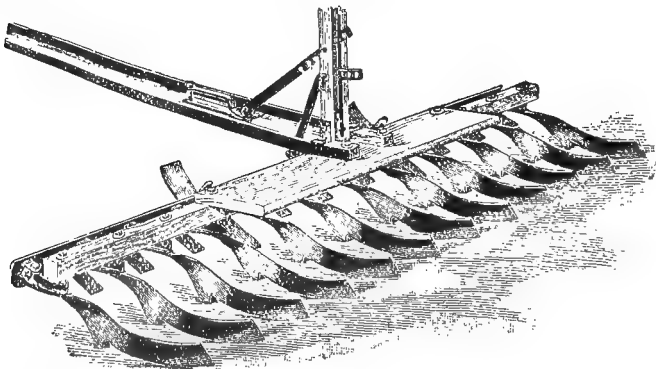

One advantage the "Acme" harrow possesses for use in orchards is, that it can be fitted with hooks and clips, which enable the driver to unhook the pole or shafts from the centre of the harrows, and attach it to either side, thus allowing the horses to walk clear of the branches whilst three-fourths of the harrow is working the soil underneath them.

#### THE DRAG HARROWS OR THE ZIG-ZAG HARROWS.

are of the greatest use in the vineyard or the orchard for collecting weeds and rubbish, and keeping the surface of the soil perfectly mellow and friable a few days after the running of the scarifiers or cultivators, or after a summer shower of rain has battered the surface of the soil down.

I would strongly advise scarifying the roadways, as well as the space between the vines, and keeping them clean and bare of weeds, as roads on which grass is allowed to grow prove a never-ending source of trouble and infection to the vineyard, the implements, in turning, carrying along with them fragments of these grasses, which soon spread about and necessitate the almost continuous use of hoes, scarifier, and harrows.

#### CATCH CROPS IN ORCHARDS.

Fruit growers with limited capital, commencing on small areas where the cost of the land and of clearing is very high, sometimes seek a quick return by cultivating peas, beans, onions, potatoes, strawberries set between the rows, until the trees come into bearing. When done with judgment the practice is not injurious in young orchards in the the South-West where the summer is cooler and moister. The amount of manure and extra working is often an advantage rather than a detriment to the trees.

As a rule, however, clean culture in the summer months is to be recommended, but there is no harm in sowing with the first rain in the autumn a few strips of barley to be cut green for stock, or sowing a cover crop, such as field peas, which are ploughed in towards the end of the rainy season to enrich the ground and improve its physical condition. A crop of field peas sown on light sandy loam, when ploughed in early in the spring, not only adds humus to the soil but in addition assimilates from the air a notable amount of nitrogen ranging from 50 to 75lbs. per acre, equivalent to that contained in 4 cwt. to 6 cwt. of nitrate of soda or in 4 to 6 tons of farmyard manures. The cost of securing this valuable fertiliser is that of a few bushels of seed and the extra labour of putting in the crop and turning it in with the plough. The value of the catch crop is much increased by applying at the time of sowing the phosphates and the potash required for the season's dressing of the land under vines or fruit trees.

## COVER CROPS OR CLEAN CULTURE.

are two methods of handling fruit land which have partisans or detractors. The objection to cover crops is that, if the amount of moisture in the ground is not sufficient for both cover crop and fruit trees, the latter suffer. Cover crops also, unless kept under control with the aid of field implements, may hamper cultivation in the early summer when fruit land should be clean.

Clean culture, if carried out too scrupulously, leads to gradual impoverishment of the soil. It cannot produce good results indefinitely, particularly where the soil is light and friable, when the leaching of nitrates and other available plant food takes place during periods of excessive rainfall, when the trees are dormant, in the wet winter months.

Desirable cover crops are those which make a good growth during the winter season and which can readily be disposed of in the spring, when clean cultivation is the established rule.

Of cover crops there are two classes—nitrogenous collectors, such as the leguminous plants: trefoils, field and cow peas, beans, vetches, lupines, etc.; and nitrogenous consumers, such as grasses and other cereals, rape, etc., which only restore to the soil what they have withdrawn but leave vegetable fibre and humus, which benefit the physical conditions of the ground.

They all improve the physical conditions of the ground, breaking up clay soil and making sandy soil more compact. They improve the water-holding capacity of the soil by adding humus to it. They remove and dry up excessively damp soil, by the agency of their leaves. On sloppy ground they bind the soil and check washaways during periods of heavy rain.

Cover crops also improve the fertility of the soil by preventing the leaching of nitrates and available plant food as already mentioned, promote nitrification, add plant food by fixing nitrogen from the air into the root nodules as in the case of leguminous crops, or by searching for plant food at depths and bringing it up closer to the surface, where it is reached by the feeding rootlets of the crop. It also breaks up plant food in the ground and makes it available. A fair leguminous crop sown amongst trees or vines when ploughed in when blossoming starts, adds pretty well 100lbs. of nitrogen per acre to the ground.

## MULCHING

is often resorted to in nurseries and places where it is not always possible to give to the trees the amount of attention they require. It acts as a screen that prevents the rapid evaporation of the moisture from the ground, keeps the surface cool; but, on the other hand, it often harbours insect pests, gives to the place an untidy appearance, favours an undesirable growth of the young thread-like rootlets of the tree close up to the surface of the ground: so

that when the mulching becomes thin, or when a protracted drought ensues, the trees often perish. Mulching is in no way superior to the thorough cultivation of the ground by means of the harrows and horse-hoes, by means of which a dry earth mulch is maintained. By this means, however, the land gets parched, and nitrification in the soil consequently checked, unless the cultivation is frequent and thorough, which is not always practicable. An effective method is to scatter evenly over the ground short fibre manure or litter by means of the cultivator or with the hoe. After some time, when the appearance of weeds make it necessary, the cultivation is repeated. By this means the moisture is just as effectively conserved in the ground, and the roots grow in their proper position. On steep inclines though, where the field implements cannot conveniently be worked, or in raising rooted vines and trees in the nursery, mulching is found of great use for smothering the weeds and keeping the soil cool and moist.

When rotted manure is used for mulching, it is not only protective, but also nutritive.

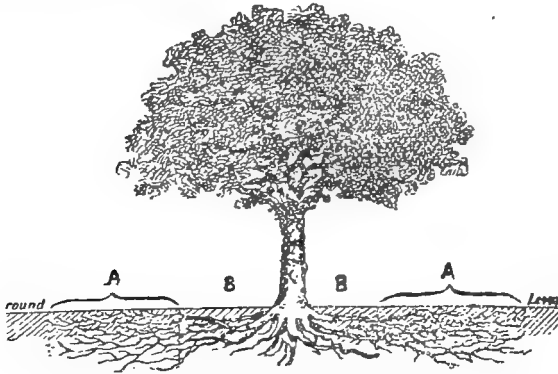

Showing at A the proper place to mulch or water.

It is generally wrongly applied right around the stem (B), where there is no need for it and where it may be injurious, instead of in a ring (A) some distance away. When thus placed it effectually protects the active rootlets underneath, and the drainage of any manure which is washed down reaches those feeding roots.

## GRAFTING

consists in inserting into the root, the stem, or the branch, as the case may be, of a plant host, known as the *stock*, a part of another plant, which is called the *scion*.

M. Vermorel tersely defines it: "A graft is a common cicatrix, or healing of two wounds placed in contact."

It is performed in a manner and under conditions such that they unite, and the scion will derive from his host, the stock, the nourishment necessary for its growth, and will bear fruit of the kind belonging to the plant from which it was taken.

On some idea of the circumstances which make grafting practicable, and of the methods suitable to the performance of this operation depend the success or the failure of the graft. To be successful, grafting must be made with the right kind of wood. The stock and the scion must be botanically related; the closer the relationship the more successful the graft. Grafting is not practicable on all kinds of plants, but is restricted to those botanically known as exogenous plants, which are possessed of pith, wood, and bark, and grow outwardly. This term is used in contradistinction to that of endogenous, which refers to a class of plants which increase by internal growth and elongation at the summit instead of externally, and have no pith, wood, and bark. Reeds, palms, and cereals belong to this order, and, for the reason referred to, cannot be grafted.

In order that grafting may be successful, the growing tissues of both stock and scion must be closely fitted together, so that the nourishing fluid may be forced by one into the other. For such an interchange to take place the growing tissues of each must be fresh, sound, and gorged with moving sap; the tissues conveying such sap must be in contact. This growing tissue is botanically known as *cambium*, a word which means "exchange." It consists of a layer of extremely delicate tissue formed between the wood and the bark. The cells of this tissue have very thin walls, and they are filled with protoplasm, or a gummy organisable nutrient matter. It shows like a thin film of mucilage. These cells develop on the one side into sap-wood or *alburnum*, which means "whitish," and on the other side into new bark, whilst at the same time fresh cambium is formed for the continuation of the work.

This fusion or union of these protoplasm cells or callus formation is more active as the temperature becomes warmer, hence spring time is favoured for the operation. Biological laboratory observations in connection with the artificial callusing of "bench-grafted" vines show very little callus formation at 68° F. at the end of eight days; at 77° F. it is plentiful, and still more so at 86° F. This explains the greater percentage of success achieved when grafting is done when spring is well on.

#### OBJECTS OF GRAFTING.

This operation, which has been practised for ages without number, possesses advantages which are often availed of by the fruit-grower.



1. It enables us to cultivate, on roots foreign to the plant itself, fruit-trees which, on their own roots, would fail to thrive in soils uncongenial. Thus the pear on the quince, the peach on the plum or the almond, can be cultivated on a wider range of soils than would be practicable were they growing on their own roots.

2. It enables us to propagate plants which could not be propagated true to name from seeds. This is the case with most highly improved plants.

3. It is an easy and valuable means of rapidly propagating some sorts of plants, and of obtaining a large amount of wood from a shoot of a rare or choice variety.

4. It also enables us to combat blights and pests by using either roots or top of varieties little subject, or not liable to, the attacks of such pests. Thus most apples are now worked on roots of the Northern Spy or the Winter Majetin, varieties proof against the woolly aphid; and also the choicer European vines are grafted on phylloxera-resistant stock.

5. It is a valuable means of speedily obtaining large trees of kinds by working scions of such kinds on the top of high stems.

6. It is a ready means of replacing varieties of little or no value possessing vigorous roots and substituting for their tops varieties better adapted to one's requirements.

7. It is often practised for uniting on the same stock branches of unisexual trees, or of plants which need be within reasonable proximity to become fruitful. This plan is recommended in the case of the Smyrna fig, which is sterile unless fertilised by the blastophaga wasp, which dwells within the Capri fig.

#### GRAFTING TOOLS AND MATERIALS.

A saw, a pocket-knife, and a chisel, dexterously used, are often the only tools used for grafting. Those tools, however, best suited for the work have been described in the chapter on pruning.

The *knife*, which is used for cutting and facing and preparing the grafts, should be kept sharp, so as to make a clean cut.

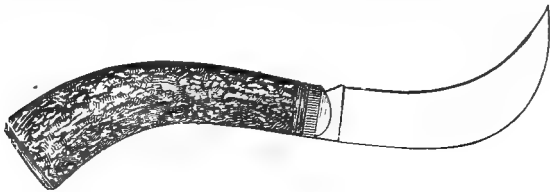

Grafting Knife.

The *saw* should be thin, fine-toothed wide-set teeth, so as not to clog. It should be kept well set.

Two good patterns of such saws are here illustrated. They are thus described by Mr. B. M. Lelong, the late Secretary of the State

Board of Horticulture of California. The lower one—a bow saw—is provided with a handle which fits closely into the hand. Both ends of the blade are fastened by means of a little screw on to a bolt having the other end riveted into a countersunk hole. The blade can thus be turned at any angle, or it may be kept in one position by tightening the thumb-screw at the end near the handle. Two small pieces of wood are riveted on either side of the bow at the lower end, which serves as a handle to prevent injury to the

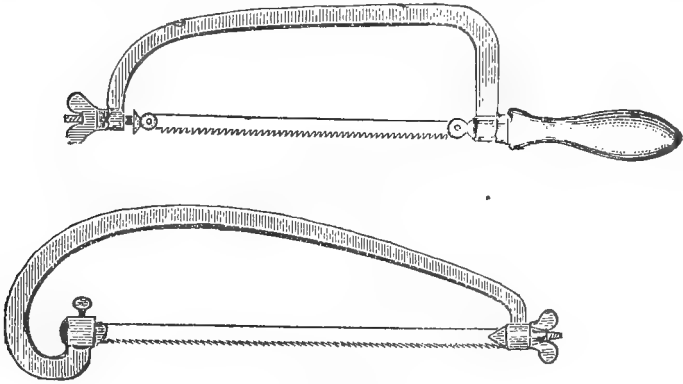

Pruning Saws.

hand. The bow is made of steel, and springs a little. These saws can be made by anyone, and for cutting large limbs have no equal, as the blade being thin and narrow, and the teeth set wide, will cut through a limb with great rapidity, without sticking or getting pinched in the cut—a difficulty met with in many other saws. The blade may be reversed if one chooses, and made to cut by drawing it instead of shoving. In this way they are not so readily broken.

The top saw is another pattern, this one having a handle about 16 inches long, and the blade guided by it. For using it the handle and bow are grasped together by the hand, which sometimes is very awkward, especially when the large limbs or a considerable number have to be cut. In any case it is more tiresome to the hand than the first one mentioned.

#### *Chisel and Mallet.*

For grafting stout branches a chisel and mallet are required. The figures illustrate convenient tools of that description. An old file can be turned by a blacksmith into a very serviceable chisel. The prong at the end is useful for keeping apart the split when the graft is being inserted.

The mallet is not absolutely necessary, as any piece of wood will do, but is convenient, and one made of tough hardwood answers

the purpose well. A hole is bored in the centre with an auger, a handle driven right through, and a peg inserted through the projecting end of the handle at the other side so as to prevent it coming off.

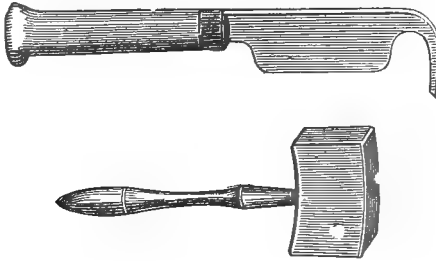

Chisel and Mallet,

#### *Tools for Bench Grafting.*

Special tools have been devised for preparing both stock and scion, preparatory to uniting them. This work is often done at so much a thousand grafts, and can be effected indoors and at any time in the winter. The illustration shows such an apparatus as is used for the purpose, and the outlines of the work turned out.

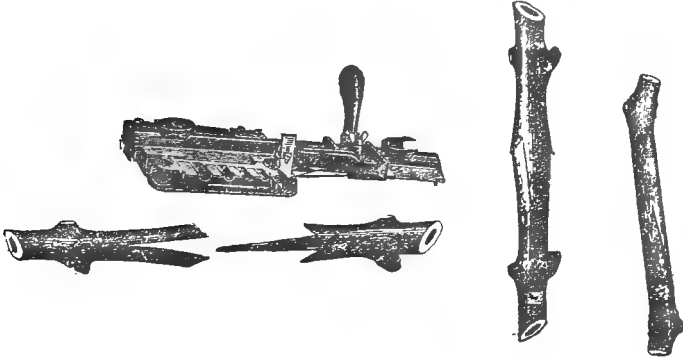

Polygreffe Roy.

#### *Waxing Pot.*

Where waxed cloth or waxed paper is not used, the grafts are smeared with plastic grafting wax by means of a brush.

The proper consistency is obtained by placing lumps of the grafting wax in a "glue-pot." The vessel dips in a hot water bath, which is heated by means of an oil lamp placed underneath. The wax is thus kept soft, but is not exposed to burning, as it might should the pot be placed in direct contact with the flame.

*Grafting Wax.*

Several formulæ are given for the preparation of grafting wax. They all, however, contain beeswax, resin, and either tallow or raw (not boiled) linseed oil.

In warm regions, where the grafting wax is apt to run, raw linseed oil is often preferred to the tallow, and the proportion of resin is increased, whilst that of the beeswax is reduced, the cost being thereby also reduced.

Wax made of the following proportions, and well pulled, will not crack, and will be little affected by the weather:—

Beeswax	..	..	..	..	..	1 to 2lbs.
Resin	..	..	..	..	..	4lbs.
Tallow	..	..	..	..	..	1lb.
or						
Raw Linseed Oil	..	..	..	..	..	$\frac{3}{4}$ pint.

Slowly melt all together, stirring well to cause the ingredients to better incorporate with one another. When ready to pull, in 15 to 20 minutes, pour into a bucket of lukewarm water. Then grease the hands to prevent the wax sticking, and pull the wax until it becomes light yellow and tough. Make into balls of convenient size, and throw into a bucket of cold water to stiffen, and use when required. If too hard then, put a lump into warm water for a few minutes, and it can soon be worked with the hands. Some prefer to put the wax on hot and in liquid form; a small paint-brush is convenient for this purpose; but this method is more wasteful of material. The wax can be applied safely much warmer than can be borne by the hand, but should be well below the boiling-point of water. Wet the fingers before using.

*Other Coverings.*

*Gum shellac* dissolved in alcohol is too expensive, and it also cracks.

*Paint* is not good, as it contains oil, and that deadens the bark on the rim and does not heal very well.

*Grafting clay* is cheaper, and very serviceable. It is made of one-third part cow dung and two-third parts of clay or clayey loam, with a little chopped hair—as used in plastering—to prevent cracking. Beat and temper this for two or three days, until it is thoroughly incorporated. The ball of clay must not be allowed to dry, but must be kept fairly moist by the application of a little water or wet bandages. Wood ashes on the hand prevents the clay sticking when finishing the mould round the cut.

*Waxed cloth or waxed paper* are preferred by many to any of the foregoing. This material is got ready before the operation. When budding is practised it is to be recommended in preference to any other material, as it answers the double purpose of holding the bud or graft—and thus doing away with tying—and of exclud-

ing the air or the wet. It also prevents the bud or graft from drying.

Two parts of beeswax and one of resin are melted over the fire, and calico or strong muslin is dipped into it. When the cloth is saturated, all the superfluous hot wax is scraped off before the cloth cools. This is done by drawing and squeezing the cloth between two sticks, or between the melting pot and a stick. The cloth is then spread out to cool, after which it is torn, when required for use, into strips of one-quarter to one-half inch wide, and 10 to 12 inches long.

Some people roll old calico or thin muslin on a stick, and place it in melted wax. When saturated it is allowed to cool by being unrolled on a bench. It is then cut into strips to suit.

*Tie Bands.*—The best of all ties is *Raphia* fibre, the cuticle of the leaves of the *Raphia* palm, which grows on low, swampy lands in Madagascar. It is damped before using, and does not cut the bark, on which it lies flat.

For tying grafts buried underground, *Raphia* should be steeped in a solution of sulphate of copper, which makes it more resistant to rot. This fibre is sold in bundles by all seedsmen.

#### *Affinity of Stock and Scion.*

The closer related the plants put together the more perfect the graft. This rule, however, is not without exceptions; this may be due to the fact that the various systems of classification of plants, although acceptable enough, are more or less artificial and conventional. For this reason it is not always possible to state with certainty when the degree of relationship is such that grafting either becomes permissible or is of no avail. In fact, numerous examples are on record of successful grafts having been effected on plants apparently wide apart in a botanical sense, and of unsuccessful grafts between plants very closely related. Thus from the Cornell University experimental station we hear of grafts of tomatoes upon potatoes and potatoes upon tomatoes, growing well and fruiting (two *solanaceae* of different species). The tomato on potato plant bore good tomatoes above and good potatoes beneath, even though no sprouts from the potato stock were allowed to grow.

On the other hand, apple and pear trees, which botanists classify close together under the genus *Pyrus* on account of their resemblance, do not graft successfully when the apple is worked on the pear, and only unite indifferently when the pear is worked on the apple. That same pear, however, worked on the quince, which belongs to a different genus (*Cydonia*) in the botanical classification, unites without trouble.

A striking anomaly in the behaviour of two plants of the like genus, or of genera closely related, grafted together, when the one is deciduous and the other evergreen, is that an evergreen scion will

establish itself on a deciduous stock, but a deciduous scion never takes on an evergreen stock. The loquat, an evergreen, can be worked on the quince, a deciduous tree, although the reverse is not attended with success. Experience only can teach which kind adapt themselves to each other.

The popular mind is somewhat imbued with the idea that the resultant effect of the intimate union of two plants is often a cross which exhibits some of the characteristics of both parents. The fable of the orange becoming blood red in consequence of its being grafted on the pomegranate finds a fertile ground in the imagination of a great many. Some still believe that the rose grows black when grafted upon the black currant bush, and wonderful tales are told of the marvellous union of some of the most dissimilar plants. Whenever such plants strike, it is invariably owing to the fact that one of them has struck root like an ordinary cutting and then pushes forth on its own independent accord.

In a graft, both the stock and the scion continue to behave the one independently of the other, as if they had nothing in common. If a longitudinal section is made of a graft, and if that section is smoothly polished, the outlines of the original graft can easily be seen; in this is the more striking, when the grain of the wood and its colour are more dissimilar: a peach grafted on a plum offers a good illustration of this juxtaposition. This fact is at times very clearly brought to our notice by the clean rupture of the tree at the point of grafting many years after the tree has left the nursery. The only direct influence of the stock on the scion is the degree of vigour which it imparts to it. This is noticeable in the case of pears grafted on sturdy seedlings of the wild pear, or on quince roots, or again on apples worked on Northern Spy or on the dwarfing Paradise stock, and, further, on cherries worked on Mazzard or on Morello and Mahaleb roots.

A graft, therefore, only differs from a cutting in this much—that in its case the soil is replaced by the stock. Its growth is not so directly influenced by the fertility of the soil in which it grows as by the nature and the greater or lesser amount of vigour of the stock which carries it. One common stock is often seen carrying several grafts of as many varieties, and the produce from each of the individual grafts is in no way influenced by the one growing next to it.

If grafting does not affect characteristics of the fruit, it often improves the size, the sweetness of the fruit, and the productiveness of the plant. It is a well-known fact that most budded or grafted trees bear earlier and bear more evenly than trees of the same sort growing on their own roots. Indeed, experiments made by grafting and budding on seedling trees, scions and buds taken from these very same trees, have imparted to the limbs operated upon the characters of early production noticeable in worked trees; such trees

do not, as a rule, attain such large developments as seedlings, and it would seem that the operation, whilst evincing a somewhat dwarfing or weakening effect on the plant, stimulates at the same time its productive capabilities. A parallel effect is noticeable when the process of annular incision or ringbarking is applied to bad setting grape vines in order to cause them to better set their fruit.

#### FRUIT TREE STOCKS.

Of all botanical families, three—the *Rosaceae*, which comprise most deciduous fruit trees and a few evergreens; the *Aurantiaceae*, which include citrus trees; and the *vitis*, under which grape vines are grouped—lend themselves best to the operations of grafting. Even then, although the rose, the apple, pear, plum, peach, almond, cherry, and many others all belong to the order of rosaceous plants, still there are amongst these, as has already been stated, affinities which make successful grafting practicable between a few of them only. The rose requires a briar or some form of rose stock; the apple, the wild crab or some form of apple stock; the hawthorn, the pear, quince, and medlar can be more or less successfully worked on one another's stocks; the peach, nectarine, apricot, plum, and almond, although doing best on their own stock, are likewise interchangeable. Which of these several stocks answers best under particular conditions is a consideration which will be dealt with under several of the headings which follow.

#### *Apple Stock.*

The apple tree on its own root is now-a-days hardly ever grown. In Europe that fruit has for time immemorial been worked on the sturdy crab stock, or on seedling stock. This practice, however, has little to recommend itself, as there is no advantage to be gained in propagating from transplanted seedling stocks which the Americans call "whole root" stocks, as compared with the ordinary root grafts.

Where the object is the "dwarfing" of the apple, the French Paradise stock is used; this is also a European wild apple which is propagated by layering. The advantages of the dwarf, it might be said in passing, are closer planting and as near as 10ft. apart; greater ease in pruning, spraying, and picking; better resistance to the winds of autumn, which cause the fruit of high trees to fall before maturity. Although these advantages appear striking, it may also be said that trees on dwarf stock are better suited to the amateur's garden than to the orchard owner who plants for the sake of the profit to be derived.

In respect of raising apple trees, however, the old country has a lesson to learn from the Australian grower. The European methods proved a failure in Australia, where the woolly aphid (*Schizoneura lanigera*) cankered the tree and ultimately killed it.

It is due to an observing Ballarat (Victoria) nurseryman to first introduce the winter Majetin as a blight-proof stock for the apple. The roots of this stock are, however, too fibrous, and not sufficiently penetrating for an ideal stock except in friable soil, and it was soon superseded by the more robust Northern Spy, which is now adopted as a blight-proof stock not only in Australia, but is now gaining favour in America as well.

There are, besides, several other blight-proof kinds of apples, but except for special conditions none excel the Northern Spy; amongst these the Duchess of Oldenburg gives good results on sandy soils.

For the purpose of dwarfing, the trees have to be double-grafted, and the structure rests upon Spy roots, French Paradise stem, and any fancied top required. Blight-proof stocks are raised by uniting together by means of the whip and tongue, graft two lengths three or four inches long, and of the thickness of a pencil, of Northern Spy wood and roots. The union is then tightly bound with raphia fibre or with waxed calico, and when a number of grafts have been prepared they are put out in nursery beds to callus. The work of uniting root and wood can be done indoors, and is often performed by lamp-light round a table at night early in the spring. When planted out they are set in rows two feet apart between the rows and one foot in the rows; one bud only is left out of the ground. With the advent of warm weather the scions begin to shoot, and all the shoots except a strong straight one rubbed off. If Northern Spy trees are required nothing further is done, but if other varieties of apples are required these young plants are used as stocks, and are budded six inches or so above ground. As already mentioned in the chapter on budding, these buds are allowed to remain dormant all through the winter, when the stock is partly cut off and, as a result, the bud forced into growth. In early districts, and if the budding has also been done early, the bud may be started into growth directly it has taken, and the young plant may thus be set out the following planting season.

#### *Pear Stock.*

On no account use pear suckers; they prove a source of trouble to the orchardist, as they themselves sucker most abundantly, and often prove to be more shy bearers than pears of the same varieties worked on seedling stock or on quince. The best pear stocks are raised from seeds of the more vigorous and more blight-resistant sorts; they need not be the best eating sorts. The seeds are raised in sandy loam; if too thick in the spring they are thinned out, and the strongest left to grow; these are budded the subsequent winter with any particular variety it is desired to propagate. Dwarf pears are raised by working the pear scion on the quince stock. For this purpose rooted cuttings of a vigorous variety, the *Angiers*, is used.



These are slow growers, but produce at an early age very fine fruit. Some varieties, as the *Duchess d'Angoulême* and the *Bartlett*, do particularly well on quince roots; whilst, on the other hand, with some other sorts, as the *Seckel*, the quality is not so good on the quince. As a rule, dwarf pears on quince roots require a moister and stiffer soil than the standard on pear roots. When manuring these pears, the fertilisers should, besides, be placed closer to the butt of the quince stock, as its roots are not so searching as are those of the pear.

While some varieties unite well on the quince others, which would not unite directly on that stock, would do well double-worked, *i.e.*, by first working the variety that makes a perfect union directly on the quince, and then by either budding or grafting the variety that does not succeed directly on the quince. Not only, says Mr. W. J. Palmer (Momohaki Experimental Station, New Zealand), does the tree become fruitful at an early period, but it is larger and of better quality.

For sandy soil, such as occurs on the littoral of this State, the Oriental pears (Chinese and Japanese) or their hybrids are better stocks than either pear seedlings or the quince. These varieties do best on a light loam on a well-drained slope, whereas the standard or pear seedling prefers a light loam with a clay subsoil, such as is met with on the Darling Ranges, where pears of a great degree of excellence are produced.

#### *Plum Stock.*

Few plum stocks do not sucker; amongst them are the cherry plum or *Myrobolan* and the Mariana (*Prunus cerasifolia*), of which there are two varieties, the red and the white. This stock, however, does not suit greengages and some small round plums, but is a good stock for the Diamond and Orleans types. The Mariana is propagated from rooted cuttings. Seedling plums of any free growing variety are also used, as also the black Damas and St. Julian, but these only prove partly suitable. They are at times used for stocks for apricots or peaches as well as plums. Some nurserymen use ordinary plum suckers with advantage, but on this point opinion is divided; others layer plum wood, and cut off into separate plants the shoots which spring up. Plum stocks are used for the peach in preference to the peach or the almond stocks, when the ground is stiff and wet, but they are often disappointing, and the peach top often dies back with little warning. For dwarfing the plum, the *Sloe* may be used with advantage.

Mr. Hy. Copor, nurseryman, Wirrabara, South Australia:—Plums and prunes on Myrobolan are a distinct failure compared with prunes on the apricot at their side. The best stock for profit, says he, is the apricot, and if he intended planting prunes, he would use the apricot. It is a matter for regret that the conditions

in this State are not very favourable to the prune, although a decided improvement is noticed in the moisty South-West.

*Peach and Nectarine Stock.*

Peach on peach stock gives the best result. For this purpose peach stones are collected in the season, and when winter comes they are stratified in sand or in light loam in boxes out in the open. In the spring they may be put out in nursery rows. Some nurserymen crack the hard shell with a specially constructed nut-cracker, in order to obtain a better germination. When a foot or two high the tap-root is severed from the plant by pushing a spade obliquely underneath the young seedlings, which thus strike stronger surface roots. When they have recovered, they are budded, and the plants either put out next winter, or, if not vigorous enough, kept in the nursery for another year. In grafting on peach, extra care has to be taken to fit the scion well and wax carefully, as the peach bark shrinks back badly.

*The Apricot Stock.*

According to nature of climate and of soil, stocks of various kinds are used. The apricot, as a rule, does not unite very readily with its stock, and it at times snaps at the graft under the weight of a heavy crop, and under pressure of a strong gust of wind.

Apricot on apricot seedling does well on loamy soil in warm, moderately dry localities. Under such conditions it does equally well on peach stock. The resulting trees are vigorous growers, and at times are even too apt to waste on rank growth energy that should have been directed in maturing a fruit crop. Apricot roots are generally known by the reddish look of the bark when slightly scratched with the nail or a knife. Apricot on almond is not a desirable union; the trees do well for a few years, but generally die out when they begin to bear. Apricot on Myrobolan and St. Julian plum stocks have the advantage on heavy wet soil, but all varieties do not unite very satisfactorily, and in this respect the American plum stock is preferable. The plum stock, as a rule, has a dwarfing tendency, and the union of stock and scion is never perfect, whilst the tree is more liable to gumming disease.

*The Cherry Stock.*

Three stocks are chiefly used—the *Mazzard* or sweet cherries, including Bigarreus for the Heart type, and all lofty and rapid-growing sorts.

The *Mahaleb* for small dwarf varieties

The *Morello*, or common Red Pie cherry, for dwarf trees of the Duke and Morello classes.

*The Orange and other Citrus Stock.*

A number of stocks have been tried for trees of the citrus family, and while some possess special points of merit, such as rapid

and luxuriant growth, yet they are found in unsuitable localities to fail in other respects and succumb to disease. Of these, the most dreaded is the gumming disease or *mul-di-gomma*. To this affection the rough lemon (*Citrus limonum*) stock and sweet orange stock are particularly liable, more especially the former, and for that reason they are undesirable stock for flat, damp localities, and all such foot-rot regions. These stocks should only be used for high and well-drained land free from hard frost, and in such localities the rough lemon and the lime will do better than any other stock. Trees worked on this stock outgrow those of almost any other stock. They fruit early and well, but are relatively short-lived when compared with those on the sour orange.

The sour orange (*Citrus vulgaris*) is of all stocks the most resistant to collar-rot, but it requires a moist, rich soil to thrive in. It has a deep-rooting habit, which revels in moist soil rich in humus, and is particularly suitable for irrigated land. Surface cultivation is less injurious than in the case of the shallow-rooting stock.

The Pomelo is spoken of as another vigorous and resistant stock, which withstands occasional periods of drought better than does the sour orange; it does better in warm localities, free from severe frost.

The Trifoliate orange, the hardest of all citrus stock, is at times used in frosty localities, but not in every case with uniform success. The Satsuma, a Japanese mandarin, is reported to do well on it. It is dwarfing in character, and that makes it a good fruit producer. When budded to other varieties it is said to bring fruit earlier and produce oranges of good quality. Some claim that vigorous stocks, such as the pomelo or the lemon, have a tendency to produce coarse, thick-skinned fruit; they certainly seem in some measure to influence the size of the fruit, and in the case of the Navel oranges they are said to add to the productiveness of the trees.

#### *The Grape Vine Stocks.*

In few other cultivated plants more than on the grape vine is the influence of the stock so noticeable. The practice of grafting vines has for a long time been carried out, but until recent years it was almost exclusively restricted to the changing of varieties. Budding is now, in many instances, superseding grafting, with most satisfactory results. The systematic grafting of vines is, however, a more modern operation, and was devised to counteract the attacks of the phylloxera on the European vineyards. Quite an array of grape vine stocks have for this purpose been suggested, tested, and found wanting. Some are not sufficiently phylloxera-resistant; some do not readily take the graft; others are not vigorous enough; whilst others, again, fail to grow in limestone formations or have such liking for some particular character of soil, that when established on any other they cease to grow with sufficient luxuriance.

Of all the varieties tried the Riparia family, or "plain vines," the Rupestris family, or "rock vines," and the Berlandieri family have supplied the stocks required for vines grown on moist alluvial soils, or hilly and rocky localities, or on limestone country. All members of these families, again, have not to the same extent proved equally satisfactory, and a few select ones only have been found to present the conditions of a stock suitable for grafting vines on. Some of the most notable members of these families the Department of Agriculture has introduced into this State, where they are now being propagated. Every precaution, it is needless to say, has been taken against the introduction, at the same time, of the phylloxera pest, or of the other disastrous blights and rots which prey on the grapevine in Europe and America. The varieties introduced, and which are the most suitable for grafting vines to, are:—*Riparia Glory of Montpellier* (*Syn. Portalis*), *Riparia Giant Glabre*, *Rupestris Monticola*, or *St. George*, *Rupestris Martin*. The character of these varieties will be described in a subsequent chapter. Apart from these resistant stocks, other partly resistant, sturdy American vines, such as the Labrusca family, have the greatest affinity to European vines, and readily unite. Some of these varieties, such as the Isabella, Concord, are well known to most growers.

#### WAYS OF GRAFTING.

A number of ways have been devised for uniting together two subjects, a stock and a scion, with the view of building up a complete plant.

##### *Inarching*

consists in bringing together two plants growing alongside one another. This is effected by inlaying a piece, cut slanting, of a stem or branch of one plant into a stem or branch of another plant, tying them fast together.

##### *Whip Grafting.*

The method is thus described and illustrated by B. M. Lelong, of the State Board of Horticulture of California:—

This is one of the most simple of the divers methods of grafting young stocks, and is operated either in the field or indoors—on the bench. In grafting seedling stocks (one or two years) in the field, the stems of the stocks are cut off at the collar. The stems are cut by simply drawing the knife upwards, making a smooth, even, sloping cut an inch or so long; then, reversing the knife, about a quarter of an inch from the centre of this cut (towards the end) a slit or tongue is made downwards. The slit (*f*) in the stock should be made as near the top as possible, as, if made lower down, it would interrupt the flow of sap. The extremity of the scion must not protrude below (*d*) on the stock. The slanting cut is best made just above a bud if possible, this acts as a pre-

ventive to the wood dying back. The scion is then prepared (which should always contain three or four buds) in like manner as the stocks; at the lower end of the scion a sloping cut is made downwards, and, by reversing the knife, a slit or tongue is made in it upwards,

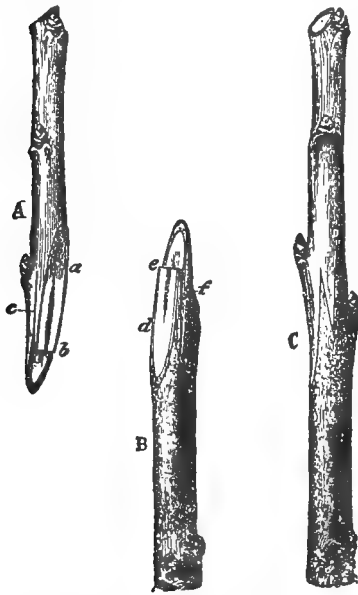

A. The scion. a. The sloping cut. b. The tongue. c. Show thickness of tongue. B. The stock. d. The sloping cut in the stock. e. The tongue. f. Shows thickness of stock from the cut or tongue. C. The scion inserted, ready for waxing.

which should correspond with that in the stock into which it is then inserted. One of the buds should be at the lower extremity to assist the union.

The bark of the scion and the bark of the stock must be placed in close contact on one side; the other is immaterial, as soon as it heals over. The union of the two, scion and stock, should be complete and fit firmly. The grafts are then either waxed over or wrapped with waxed paper.

This completes the operation. The earth may then be banked on either side with a hoe, and nothing more is done until they begin to start, when they require attention, especially in keeping them clear of weeds and all undesirable growths, suckers, etc.

#### ROOT GRAFTING.

For root grafting the seedlings of one or two years' growth are taken up and the best roots cut into pieces about four inches long. These are taken indoors, washed free from all dirt, and grafted as follows: the operation is performed in the same manner as on the seedlings, out of doors as previously described. The oblique or sloping cut or tongue is made in the root; and the scion, which should be three or four inches long, is likewise prepared and inserted, as shown in Fig. 8.

It is then waxed over, either with wax or waxed paper; the latter, however, is much preferred. The grafts are then put away in sand until planting time, in February,\* in the following manner:

\* August in Australia.

On the floor of the propagating house or shed sand is spread out from six inches to a foot deep, then the grafts are put in it, standing thickly, and covered with sand. The entire graft, to within an inch or two of the top, may be covered without injury to it. They should, however, not be kept too wet, as the bark of the grafts is liable to decay; and, again, they must not be allowed to get dry, as the bark of the graft will shrivel, and adhesion is avoided. During the time they are thus stored away the parts united (scion and stock) knit or callus over, and shortly after planting begin to grow.

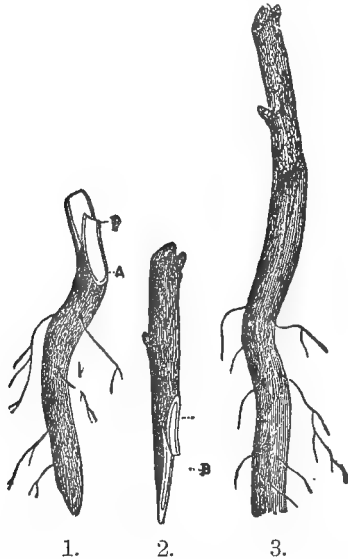

1. The root showing sloping cut at A, and the tongue at B.
2. The scion showing sloping cut at A, and the tongue at B.
3. The union of scion and stock ready for waxing.

#### CLEFT GRAFTING.

This method is mostly practised on stocks too large to be whip grafted, although it is also operated on young trees successfully. It is also the method followed for field grafting grape vines. The operation should be undertaken just before active growth takes place and before the vine begins to bleed freely, or some time after, when the shoots of the stock plant are 3in. to 4in. long. At that time the callusing gum is less likely to be washed off by the running sap, which in the first instance has not started to run, and in the second has to a great extent been used up by the now growing shoots.

On the Swan the middle of September or even the beginning of October give satisfactory results. A good day's work, when the work is well done, is 200 to 250 vines.

The stock is first prepared by being cut squarely off, as shown in Fig. 2. at *g*; a sloping cut is then made in the stock at *f*, and the top shaved smoothly at *g*, so that the point of union between the bark and the wood may be plainly seen. The blade of the knife is then driven into the stock, as shown in Fig. 1, to split it as represented. It is always best to prevent the stock from splitting or cracking clear through. This is avoided by using the knife properly. The point of the knife is driven in, as shown in Fig. 1, at *C*, and the blade is driven in at *B*, and instead of forcing the knife down farther to produce the split, it is drawn upwards and towards you, and a perfect cut without cracking through is made, as shown in Fig. 2. at *h*. The scion (Fig. 2, *A*) is cut precisely in the form of a wedge, with the part cut for insertion about an inch or an inch and a-half long. It should always have a bud at the shoulder where it is to rest on the stock, and the outer edge thicker than the inner, and inserted so that the point of union between the bark and wood on both the stock and scion will exactly coincide, as shown in Fig. 2, at *C*.\*

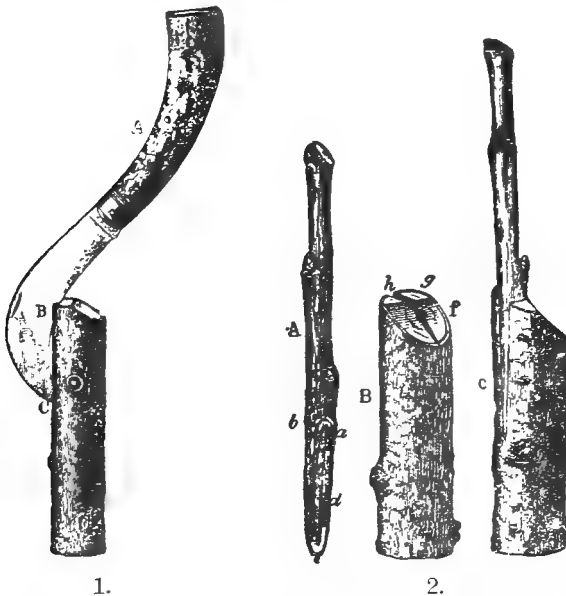

1. A. The knife as used in splitting. B. The point of the split. C. Length of split; the position (shown at B and C) shows how cracking of the stocks is avoided.

2. A. The scion, showing how it is prepared—wedge-shaped—with a sloping cut. B. The stock prepared to receive the graft. *f*. The sloping cut. *g*. The horizontal cut. *h*. The split. C. The scion inserted in the stock, showing the close fit of both, and ready for waxing.

\* This method of grafting will be found useful for changing varieties of vines and grafting stumps of vines already growing.—A.D.

On larger stocks the stem is sawed squarely off, and the surface dressed or shaved off with a knife. The knife is then driven into the stock as shown in Fig. 1, and should be to one side of the pith. The split is kept open with a knife until the scion is inserted. It is always best not to split too deeply, to allow the graft to work its way down a little and be held firmly, otherwise the graft will loosen and will not adhere. Then, again, the operator must see that stocks do not close so firmly on the scions as to crush the ends. To avoid this a small wedge is driven into the split on the opposite side. This, however, is seldom required where two grafts are inserted, as shown in Fig. 2. In most instances both scions grow, and as they are too close together one is afterwards removed. There is more than one way to shape or face the scion, but the point in question should be the most expeditious one, and it has always proved that when the work is done rapidly the grafts take better, not because it requires carelessness (which must not be inferred), but because the sooner the graft is in position in the stock, with less handling or whittling, the better. Where time is no object, the following is a very good method of preparing scions.

The end of the scion is first cut (obliquely), then a cut is made at *a* and *b* but deeper at *a*, then a shaving is taken by drawing the

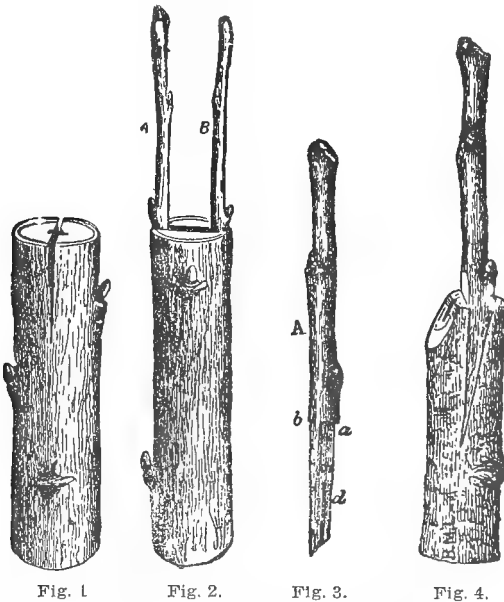

Fig. 1.—The stock split, ready to receive the scions.

Fig. 2.—A.B. The scions inserted, ready for waxing.

Fig. 3.—A. The scion; *a.b.* The horizontal cut severing the chip on either side; *c.* The wedge. *d.* Pith. *e.* Point of scion, cut obliquely.

Fig. 4.—Graft inserted in stock obliquely.



knife from the end towards *a* and *b*. This scion differs from the one previously described only in the method of preparation. It is inserted in a like manner. The method of inserting the scion and the splitting of the stocks is not confined to those described, and growers generally find a way which the method operated can, in some way or another, be improved. For instance, where the splitting is done obliquely instead of parallel, the grafts are better. This is especially so in grafting prunes. The bark of the scion and stock come obliquely together, and the scion is held firmly in place.

The accompanying figure illustrates a method of renewing the top of citrus trees or of vines by means of cleft grafts. When vines are grafted the operation is best done in the early spring when the sap begins to move. The top of the vine is sawn clean off half an inch to an inch below the surface, the earth around having been removed with a spade or a hoe, the stump split with a chisel, the two lips of the split trunk forced apart by means of a small hardwood wedge. To guard against the split following curly fibres the stump can be sawn straight for an inch or two and then split by means of the chisel. One or two scions of the sort it is desired to grow are cut two eyes long. The basal side of the scions is cut bevel shape, and sharper on the inner side than the bud side, which is close to the stock. These scions are then pushed gently down the cleft, where they fit snugly and smoothly, with the inner bark of both stock and scion in close contact. The hardwood wedge is removed, the lips of the split trunk close in on the wedge-cut scions,

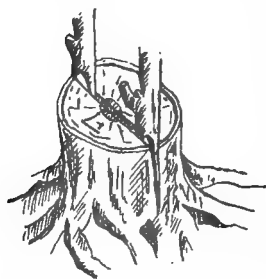

Cleft Graft for Old Trees  
or Vines.

and nothing else is done except to bank moist earth in a small mound over the cut. This earth absorbs the dripping sap from the old trunk and keeps the wound well drained. The use of grafting wax would check the flow of the sap and prevent the formation of the knitting tissue or callus gum. September is the best time for grafting vines. At that time the stock is beginning to burst into leaf; the scions, which consist of last year's wood, should have been kept back in cool sand.

#### BENCH-GRAFTED VINES

take four years before they bear a good crop.

1st year they are calloused in nursery beds.

2nd year they are transplanted to the vineyard, where they will establish themselves permanently.

3rd year they will grow stronger, and are shaped and trained, but they will not grow bearing-wood until the

4th year, when they bear.

## THE SUMMER BUD OR "YEMA" GRAFT OF THE VINE.

Following on the devastation by the *phylloxera* of the Victorian vineyards, reconstitution by means of resistant stock grafts has of late years been vigorously carried out. This work, entrusted to Mr. F. de Castella, the Government Viticulturist, has been crowned with signal success. After a voyage of investigation through the in-

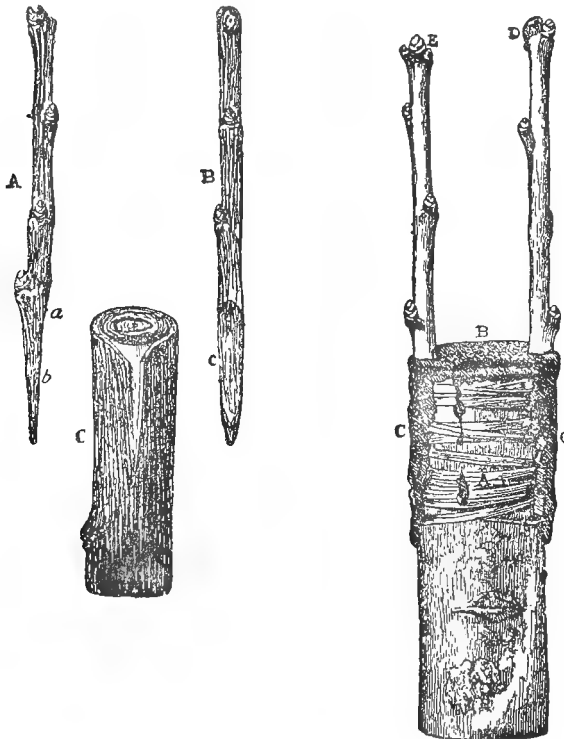

Fig. 1. Grafting under the Bark.

Fig. 2.

Fig. 1.—A. The scion, side view, showing thickness of cut at points *a* and *b*. B. Scion, transverse view, showing how faced at *c*. C. The stock, showing how it will cut off, and the incision made to receive the graft. Fig. 2.—Operation complete.—Stock grafted with two scions and applicable to stocks with one scion. A. Twine, showing how it is tied. B. Waxed top surface. C. Waxed on the side covering graft. D. Graft waxed at the end. E. Terminal bud, waxing at end not required.

fectured regions of Southern Europe, Mr. de Castella introduced and adapted to Australian requirements many methods which have proved greatly beneficial in connection with the task entrusted to him. Amongst these the summer bud or "Yema" graft has simplified field grafting, and has proved a distinct advantage to vine-growers.

In prefacing his remarks on the subject, Mr. de Castella points out that a vineyard on resistant stock may be established by—

1° Planting nursery-raised “bench-grafts.”

2° By “field-grafting” European or “Vinifera” grape vines on established resistant vines or stock.

Field grafting is more in favour in Spain and Portugal—where the spring is warmer—than in Northern Europe. In our warmer Australian climate results are generally very satisfactory.

“Yema” means in Spanish, a bud or eye—the germ of anything, in fact. Whereas “budding” is practised above ground, on green herbaceous canes, with the wood-core of the bud removed, the summer bud graft consists in cutting deeply into the wood of the vine, almost to the pith; the wood-core of the scion-bud is not removed. That bud is taken on the shoots of the current year, well summered and carrying ripened buds. The main differences to be found between the “Yema” and ordinary grafting are, 1° the season when it is carried out; 2° the very small dimensions to which the scion is reduced.

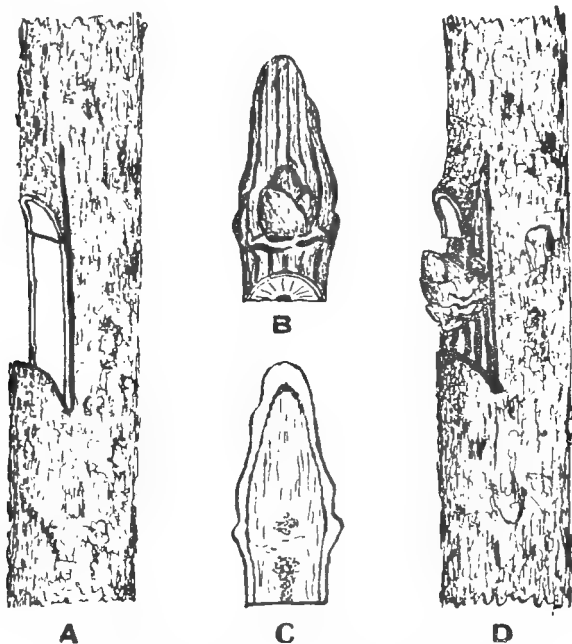

Victorian modification of Yema Graft (Rounce's).

A. Preparation of stock. B. Outer view of scion bud.  
 C. Inner view of same. D. The completed graft. (F. de Castella.)

The fig. illustrates the method which consists in cutting into the wood of the stock, a socket into which a piece similarly shaped, carrying a bud, is carefully fitted and bound with raffia fibre.

This graft does best where there is but slight difference in character between stock and scion, as in the case when a one or two year old rooted vine is grafted in the vineyard, for it is essential that the cambium layers of stock and scion correspond as accurately as possible. If the stock is of a larger diameter than the scion, the "cleft graft" should be preferred. August is the best season in Spain, and this corresponds to February in Australia—a convenient one when there is a slack time before vintage. When fitting the scion, the stock can conveniently be bent to elongate the socket while inserting the scion.

After grafting, the whole stem of the vine is mounded up with loose soil which maintains an even, dry temperature. The growing canes are not cut off, but continue to grow, thus maintaining an improved condition of the sap which helps the knitting process.

During the winter when hoeing, this mound is removed, and the tie is cut if it has not already rotted away. In case of failure the bud-graft is seen shrivelled, and can be rubbed off with the finger. The summer bud-graft is inserted about three inches above ground, and should it fail then the vine can be cleft-grafted. A modification of this graft has been introduced in Rutherglen, as illustrated on page 109.

With scions of the same diameter as that of the stock—about half an inch or under—the buds are so firmly held that no tie is necessary. One man makes about 350 grafts in a day.

It is important that the stock be well in sap and have plenty of life in it as happens after summer rain. Vines planted in August are usually fit for grafting in February.

When a number of vines are to be grafted, the season being the hottest of the year, buds should only be cut for a few hours' requirements, and they should be kept in a piece of wet bag. The knife found best adapted for this work is shown in the figure, and is made by Messrs. Barker Bros., of 262 Victoria Street, Richmond, Victoria; it has a stout wooden handle such as can be firmly gripped, and should be sharpened to a razor edge.

After mounding up, and if the buds are tied to the stock, it is advisable to inspect one or two occasionally and see whether the string wants cutting. It generally rots without interference. A short stake of about two feet is driven alongside the stock.

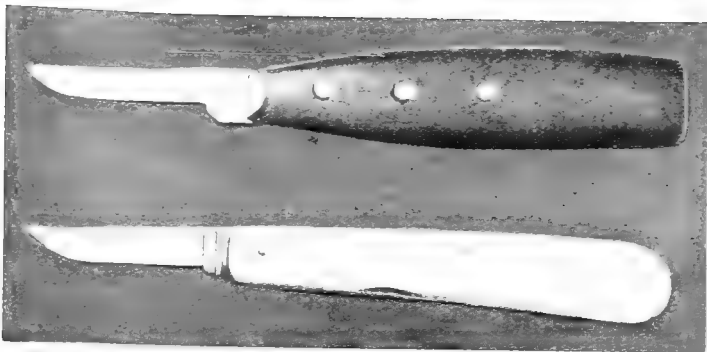

Knife made by Messrs Barker Bros., Victoria, for summer budding. The blade does not fold. The lower knife is generally used for budding citrons, roses, etc. (F. de Castella.)

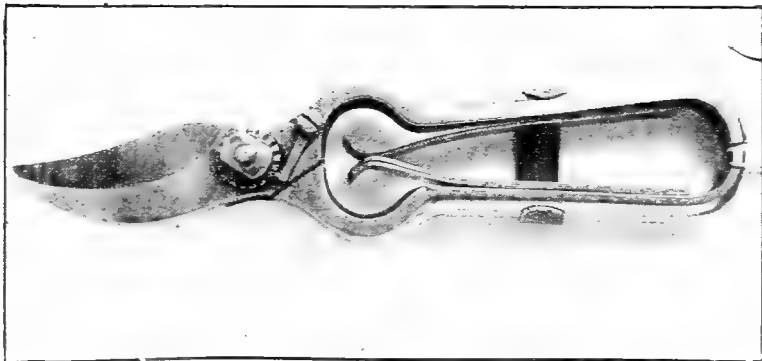

Ricser Scatur.



In the winter time the canes are roughly shortened to facilitate cultivation, and these are further pruned in August as shown in the figure. The spurs left at the higher level will grow, draw the sap

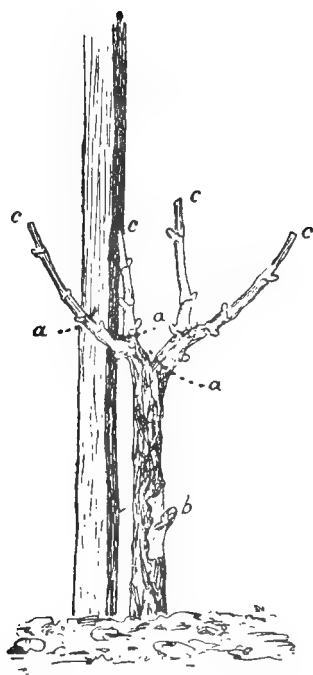

Young resistant vine in August, twelve months after plantation. The stock was bud-grafted at *b* the previous February. The canes were roughly shortened during winter at *c, c, c, c, c*, to facilitate cultivation; they are further pruned in August at *a, a, a*.

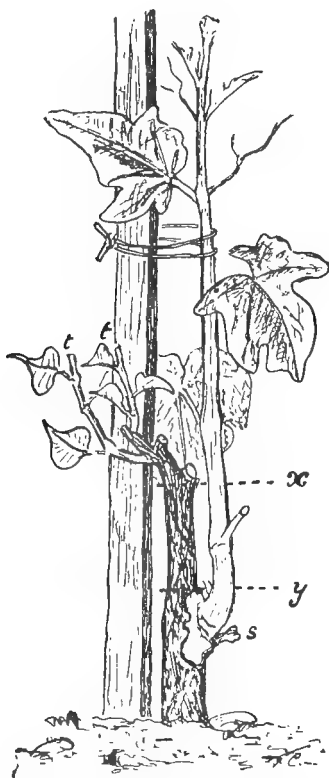

Same vine seen in October, or early November. The stock shoots have been severely stopped at *t, t*, and the shoot from the bud graft has been tied back to the stake. The stock may be cut back at *x*, either in August-September, or as late as December. On no account should it be now finally cut back at *y*; this must not be done until the following winter, which will be the second one after the vine was grafted. (F. de Castella.)

past the inserted bud and cause it to send up shoots, which are tied to the stake lest it snaps at the point of union. When growth shows,

the growth on the stock plant is cut back, but a stump of wood still left above the graft to be removed at pruning time in the winter.

Cut worms should be particularly watched as the shoot bursts out, and poison bait laid to prevent any damage.

Suckers issuing from the stock or roots from the scion are removed as in the case of the cleft graft.

When these details have been attended to, strikes averaging 80 to 90 per cent. are usual, and should the Yena-graft fail, then the opportunity offers next spring to cleft-graft the vine.

#### VINE BOTTLE GRAFT.

An ingenious method of grafting vines in full growth, or for the matter of that many evergreen or herbaceous plants, is described and illustrated by the experimenter, Mr. W. C. Grasby, the agricultural editor for the *Western Mail*, in the issue of the 5th February, 1920. The method referred to by Charles Baltet in a work on grafting and budding has for some years been successfully applied to vines by Mr. Grasby, and although not of great commercial importance is interesting in connection with home gardens.

*Time for the Work.*—The method of bottle-grafting, says Mr. Grasby, may be adopted either in spring, when the vine is starting into activity, or any time later in the season after the season's growth has become sufficiently matured for the operation. I believe, however, that the best time is either in March or the beginning of April,\* the actual time depending upon the conditions of the vine. At this time the wood to be used for scion has assumed a brown, woody, mature appearance, and at the same time the vines are normally still in a state of growth so that healing of the wound and the growth of the scion and stock takes place quickly. The object is to obtain a dormant graft ready to start after the vines have been pruned the following season.

*Method of Grafting.*—The method to be adopted for the March or April grafting will be best understood from Fig. 1. It will be noticed that the scion consists of a piece of wood with one bud above the point of incision in the stock, and a long heel with two or three buds projecting below. The lower end of the scion is cut off just below the joint or node, while on the upper portion of the scion a piece of wood an inch or so above the bud is left.

*The Summer Graft.*—The method of grafting when the vine is active is what is known as whip and tongue. A downward incision

---

\*Autumn months.



is made in the current year's wood of the stock, and an upward incision just below the bud is made in the scion. The tongue of the scion is carefully inserted in the cut of the stock so that the cambium layer of stock and scion meet exactly on one side. If the scion and the shoot on which it is grafted are of the same thickness, the cambium layer will meet on both sides, which of course results in a double bond of new growth. But one cannot always choose his scions to match in this way, and perfect results can be obtained if there is perfect union on the one side.

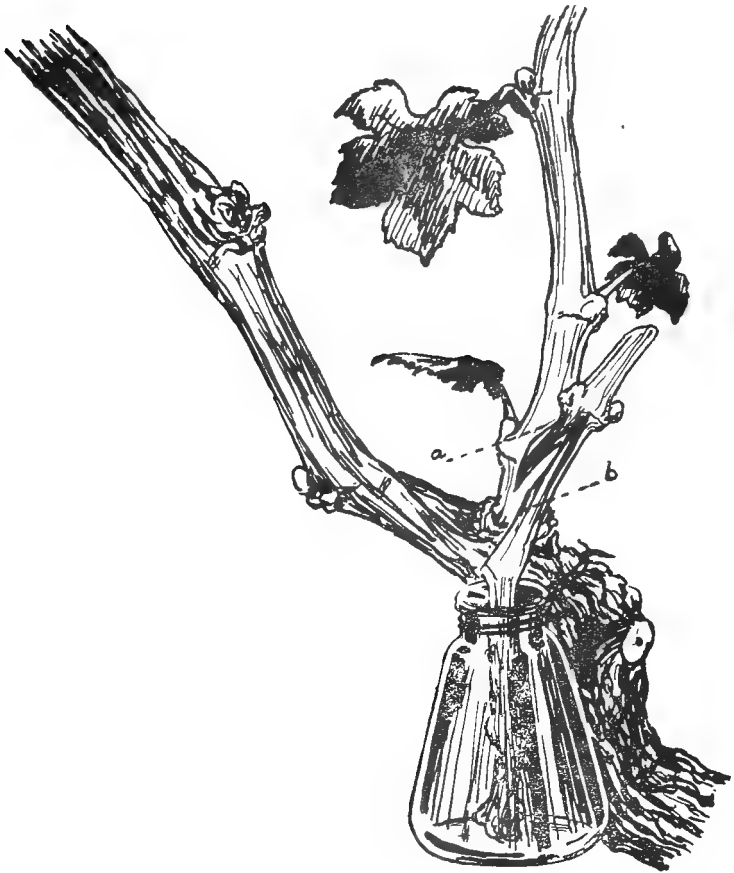

Fig. 1.

Summer Bottle Graft (Grasby).

*Tying.*—As soon as the scion is inserted it should be carefully and tightly tied in either with raffia, wick cotton or narrow strips of calico strong enough to allow of tight binding. The method is shown in Fig. 3.

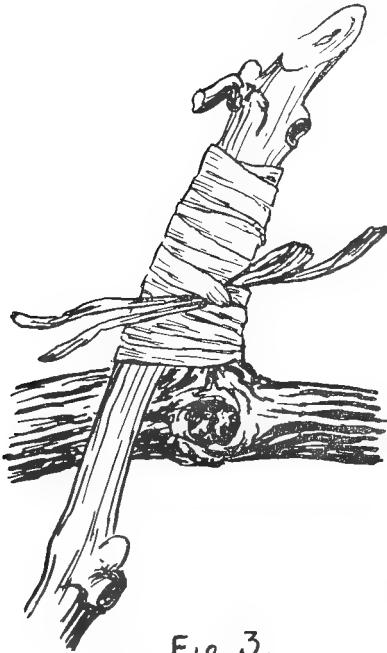

Fig. 3.

Tying the Graft.



Fig. 4.

When to remove Bandage (Grasby).

*Waxing.*—After the graft has been well bound, the top end of the scion and the whole of the binding should be covered with a coat of grafting wax. By careful and effective binding I have had grafts take without the wax. The use of waxed calico for binding renders after-waxing unnecessary. Everyone knows that the great point in getting a graft to take is to prevent the rapid drying of the sap at the wound. I believe an effective result can be obtained by thoroughly enclosing the graft with grafting clay, but it has to be remembered that in March the air is very dry, and for that reason the grafting wax, besides being less troublesome, is more effective.

*Providing the Graft with Moisture.*—It is well known that it is exceedingly difficult to get any graft to take in hot, dry weather on account of the fact that the scion dries up before the union takes place with the stock. By inserting the heel of the graft in a bottle filled with water and hanging the bottle as closely as possible up to the graft, the water in the bottle provides a moisture supply for the scion while the union is taking place. I find that in a very short time roots put out from the base of the heel of the graft, and before the end of the season the bottle may become quite filled with roots. From time to time the bottle must be refilled with water, so as to keep up the supply. In refilling, I run the water to the bottom of the bottle through a funnel and so prevent it from becoming stagnant. I also sometimes use charcoal for this purpose.

*Cutting off the Heel.*—In the case of the spring graft, as soon as it is known that the graft has taken and growth is taking place from the bud, the heel of the graft may be cut off at the line A shown in Fig. 2. But it is not necessary to cut it off at this time, provided the bottle be kept filled with water, and in no case should there be hurry in cutting it off, because the supply of water in the bottle taken up by the roots helps to nourish the shoot on the graft and results in a better growth during the season."

When the dormant graft is made in March or April, as shown in Fig. 1, and it takes properly, the whole of the shoot of the stock above the graft should be cut off at A (Fig. 1), at the ordinary pruning season; but it is a matter of choice with the grower whether he cuts the portion below at B, or allows it to remain in the bottle for a year. If he allows the bottle to remain he must take care to keep it full of water. If the bottle be kept filled with water it will help the growth of the graft during the growing season, but if he allows the bottle to dry out, that dry heel below the graft is a source of danger and weakness. Therefore as a rule it is wise to make both cuts at A and B in the August of the same year as the graft was put in.

#### GRAFTING UNDER THE BARK.

This is a very simple operation, and is performed just as the sap begins to rise in the stocks. Young peach, plum, and pear seedlings put forth quite early, and are grafted at any time after the leaves begin to grow by the following method:—

The stocks are sawn off, and with a knife a vertical incision is made on one side of the stock, the same as for a bud. The graft is then prepared by simply facing on one side, as shown in Fig 1 at *c*. It is then inserted in the slit, in the manner that buds are inserted, and is then tied and waxed over. For tying, waxed cloth

is greatly preferred, as it serves for both purposes—that of tying and waxing—in one operation.

#### CROWN GRAFTING.

Trees, and especially citrus trees, are at times killed to the ground by the disease of gumming or are cut back by severe frost, and whenever the roots are healthy and well established there will be a great saving of time, instead of rooting up and replacing the tree, to cut it down below the surface of the ground to where the wood is sound and cleft grafting it, or perhaps better still, *crown grafting* it. Large useless trees can also be renewed with comparative ease by means of the crown graft. It is particularly suitable for trees like the fig and the walnut which, on account of the large amount of pith, were considered hard to graft on account of the difficulty of preventing the air getting into the pith and the scion drying.



Crown Grafting old orange stock (H. J. Webber).

For this purpose scions are procured of mature wood from a thriving tree of the kind wanted, cut five to six inches long and sharpened into a long slanting cut, as shown on the figure. These two or three on one crown, to make sure that at least one will grow, are pushed between the bark and the wood, preferably in the creases and concave portions of the trunk, when the bark can with less danger of splitting be pressed out. A sharp prod made of the handle of a tooth-brush filed and sharpened at one end like an awl,

and fitted with a handle, is pressed between the cambium or growing wood and the bark. Bone will not turn the sap like steel or iron.

In this way the scion will be held firmly against the trunk without the assistance of any ties. When made under the ground, the moist clay and cow dung moulded round the graft will exclude the air which would otherwise interfere with the success of the operation. When done above ground, small strips of waxed cloth over the cavity formed between the bark and the wood are necessary.

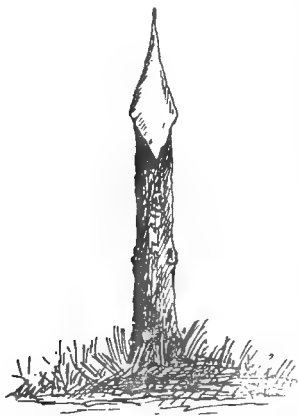

Some gardeners use no grafting wax, but lay a few of the leaves of the plants on the grafts, the whole being tied up hermetically with a cap of strong paper. The paper being a non-conductor, the moisture of the leaves being brought out by the heat of the sun keeps the grafts damp and prevents them drying. This cap, however, is liable to harbour insects that eat the buds as soon as they open.

#### GRAFTING THE OLIVE.

The olive is most successfully grafted, says Lelong, during the months of March and April,\* but preference is given to those grafted in March, by the following deft method:—

In this method the stocks are not split down the centre as in the old way, but instead, the cut is made obliquely, so that the barks of the stock and scion may come obliquely together, and in which way the grafts make a surer and better union. The graft is faced on both sides, to be large at the surface side and thin at the inner side, exactly in the shape of a wedge. The graft is driven down as far as it will go, and made to fit exactly, the barks of the scion and stock to be even on the surface side, the other side does not matter, as the scion unites with the stock of the first only on the surface side, and in time both sides heal over. The graft having been inserted, it must be tied and waxed.

#### POINTS TO OBSERVE.

For tying, cloth or twine may be used, and the wax applied over it. In grafting nursery trees in the field it is best to graft them low, the grafts to be covered with earth within an inch or so from the top, leaving as little of the graft exposed as possible.

\* August and September in Australia.

This is a protection to both scion and stock, especially from scorching heat, which causes grafts and stocks to die back when left exposed. The leaves of the grafts should never be broken, but cut, nor must they be cut off entirely; at least one-third of the leaf should be left (as shown in the figure) to prevent the graft from dying before it has had time to unite with the stock. Neither must the entire leaf be allowed to remain on the graft. The trimming of the leaf prevents it from carrying off too rapidly the fluids by evaporation.



Scion.

Stock.

#### AFTER-CARE OF GRAFTING.

After vines are grafted flush with the ground, they should be protected by a small stake, driven on the side of the prevailing winds in summer, to which the young, tender shoots of the graft can be tied as they appear. The stock will also often push forth tender suckers from underneath, these should be pulled off as they appear above ground or removed by cutting with a knife; the flow of sap will thus run without interruption from the stock to the scion.

As regards trees, ligatures are cut off directly it is seen that the graft is growing; and if the shoots from the graft are pushing forth too luxuriantly, they are pinched back to save them being carried away during windy weather. At the time of grafting old trees it is advisable to whitewash the stems to guard against sunburn; some people wrap them up in sacking.

Suckers will soon put in an appearance. These it is not advisable to rub off entirely, but a few should be left growing the first year so as to take up the surplus sap and maintain a healthy root growth.

## BUDDING

is the short name for bud-grafting, and is performed during the growing months, when the sap is moving, thus providing material for healing the wounds the operation entails. It is performed by removing from a shoot of the current season's growth a suitable bud and inserting it in the proper manner under the bark of another tree, sufficiently closely related to insure the absorption by the bud of the nourishing fluid of the host plant. When a tree is lop-sided, a symmetrical head may at times be provided by inserting under the bark of the tree a bud removed from one of its own branches in such a position that the resulting growth will fill the unsightly gap.

Buds inserted early in the season are called "spring buds," and become active at once, showing towards the end of summer



A. The point which should not be used, as the buds are generally blind. B. Point from where the buds are developed. C. Beyond this point the buds are too tender, and should not be used. D. Indicates the scion, or budding stick, to be used, being between points B and C. E. The scion, or budding stick, trimmed ready for budding.

marked growth; whereas buds put in late in the summer or in the autumn are called "dormant buds," and remain inactive all through the winter and until next spring.

Such questions as: "Influence of stock and scion" and "choice of stock" are discussed in the chapter on grafting.

Several conditions are necessary in order to favour the union of the bud and the stock. The seeds must be well developed and matured. The figure illustrating the kind of buds to select is taken from Mr. B. M. Lelong's paper on budding, published by the State Board of Horticulture of California.

The bark must raise freely from the stock; the more luxuriant the growth the more active the flow of sap.

The time for budding varies greatly according to trees; thus peaches, almonds, and cherries ripen their buds early, and may be budded in the early summer; if budded later, in the autumn, they remain dormant through the winter. Apples and pears, which are slower of growth, are generally budded later in the summer and lie dormant until next spring. Citrus trees are budded all through the summer, and whenever the sap is running more actively and young shoots sprouting readily. Plump buds from healthy young round wood are preferable to those taken from angular wood.

Immature buds remain dormant in the stock until they have developed, sometimes until late in summer, or even until next spring.

In order to hasten the development of young buds, the tips of the branches it is intended to use are sometimes nipped off; the shoots are thus made to harden, and the buds are taken when they just begin to start growing again.

#### BUDDING MATERIAL

consists of a pruning knife to cut the scion bevel shape (such a knife is illustrated in the chapters on grafting and on pruning),



Budding Knife.

and a budding knife, which has a sharp round blade and a flat handle to raise the back of the stock. In budding, sharp tools are to a great extent the secret of success.

Wrapping material is also required and consists of raffia fibre, cotton cord, yarn, or strips of waxed cloth. These are made of cheese cloth or coarse calico folded into convenient sizes and dipped into molten beeswax and resin, two parts of the former to one of resin. The surplus wax is then scraped off by pulling the calico between a stick and the edge of the melting pot. The waxed calico



is then spread to cool and then torn into strips of the desired size, generally a  $\frac{1}{4}$  in. to  $\frac{1}{2}$  in. wide, and about 12 inches long when required for use.

These waxed strips hold the buds firm, prevent them from drying, and keep out moisture. One disadvantage they have, is to make the fingers more or less sticky, which is a decided objection when a great number of buds have to be inserted.

#### HOW TO BUD.

The operation, to be successful, must be so performed that the freshly-cut inner bark of the bud is firmly placed in close contact with the growing wood or cambium of the host.

Several methods are used for that purpose, but there is one which is more particularly practised amongst nurserymen and amateur orchardists as well, and which is known as shield or "eye" budding. It is the one I propose to describe, as it is suited to most deciduous trees as well as to citrus trees.

If the tree to be budded is too old, it is necessary to prepare it for the operation by cutting off the top the previous autumn and

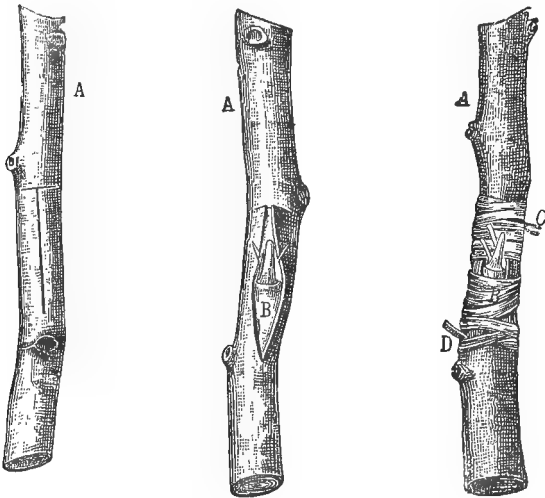

A. The stock. The transverse cut. The vertical incision.

A. The stock. B. The bud inserted.

A. The stock after budding. B. The twine as tied. C. The tie at the finish. D. The tie at the beginning.

rubbing off all the shoots crowding around the stumps, except those required for budding. The figure illustrates an old, coarse citron tree thus rejuvenated and ready to receive buds from some choicer varieties of citrus fruit.

With the blade of the budding knife a longitudinal cut is made through the bark where the bud is to be slipped, and either at the top or at the base of that cut, a horizontal cut as well is made, so that the two cuts present the appearance of a letter T, standing either straight up or inverted.

This cut should be made a few inches from the ground if nursery stock is budded, or at any convenient height if other trees are operated upon. In all cases, the stick operated upon should have a smooth, young bark, easily lifted. When the vertical cut and the crosscut are made the corner lips are slightly raised with the blade or with the flattened ivory handle. This done, pick up the stick of bud wood and cut out a plump young bud, making the section about 1 in. to 1½ in. long, and a little longer below the bud than above. Some advocate picking out the portion of wood cut out with the bud, but good result is obtained without doing this. Then, with the point of the knife, slightly raise the bark, slip the bud in, and gradually push it in under the bark. If in the proper condition for budding, the bark lifts readily. The bud is now ready for tying or for wrapping with the waxed cloth. When doing this commence slightly below the crosscut if it is at the bottom of the vertical cut, or slightly above if it is at the top; wrap pretty tightly around the stock over the bud in a spiral manner, each turn slightly overlapping the previous one until the whole cut is covered, then twist the waxed strip back and press the end against the folds already made, when it will adhere. In changeable weather it is well that the strips should overlap from above downwards, so as to prevent water running down the stem penetrating the cut. In Western Australia, where fair weather occurs pretty well all through the budding season, darning wool or rafia fibre are often used for tying the bud.

#### FORCING THE BUDS.

After 10 to 12 days the buds are examined, and if plump, green, and alive, they are allowed to remain covered for another week or two, when the ties can be removed entirely. If the bud is dead, a fresh one can be inserted in a fresh cut. Left too long, the tie may cut into the growing tissues of the stock and smother the bud. If it is desired to force the buds, the tops of the branch on which the bud has been inserted is partly cut off 10 to 12 inches

above the bud, once it has been ascertained that the bud has taken. A brush of foliage is left on the resulting stump to draw the sap beyond the bud, which at the same time will assimilate some of it and will soon start to grow; unless this is done, the stump may die back and endanger the bud. The illustrations taken from Mr. Lelong's paper will explain how this is done. When the shoot from the bud has reached a sufficient length it is often loosely tied to the old stump until quite strong and tough, when the old stump



A. The brush left on the stock to induce the bud to start, by acting as suction—drawing up the sap. B. The stock. C. Point where the bud may be tied to protect it from breaking. D. Point where the old stock is to be cut away, the dotted line below it indicating how much the bud is endangered by cutting lower than this line.

is removed altogether and cut smooth a little above the bud, so that it will soon heal over without forming an ugly scar. It is not

necessary to protect the wound with gum, shellac, or any kind of covering. "Dormant buds" are often left on the stock, and are only forced in the spring, so as to insure a stronger growth. In that case the top of the stock is left untouched until the time comes to force the bud.

#### BUDDING THE VINE.

Budding is not generally resorted to for propagating the vine, grafting having hitherto been almost exclusively used for bringing together stock and scion. The budding of the vine can, however, be performed just as easily as the budding of the apple or the pear, and is a most rapid and valuable means of propagation.

Of the several methods in vogue for this purpose, the one known as Salgue's Green Budding, after the name of its first sponsor, is one of the easiest. In order that it should prove successful, the stock as well as the scion should be carefully chosen.

The operation is performed in a slightly different way to the one already described above. The bud, which is also an eye or shield bud, is carefully chosen from the buds at the tender end of the shoot of the vine it is intended to propagate. Few desirable scion buds are available for the purpose on the young shoot; a little

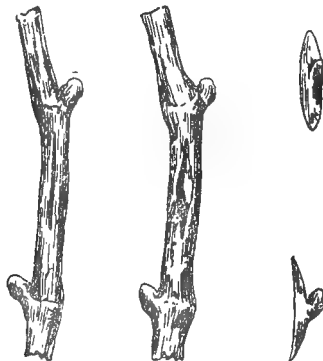

experience soon teaches which are those suitable for the purpose. They are recognised by the following characteristics.—When a green shoot is cut lengthwise the tissues, which are lignified and

provide with pith towards the base, become more tender as the terminal buds are reached, until towards the end they are quite tender and almost transparent. Those buds, at the third to fifth node from the top, show a diaphragm or partition through the tissues, but are yet unprovided with pith; they are desirable eyes for budding. To effect this a longitudinal section of  $1\frac{1}{2}$  inch is made with the grafting-knife on any internode of the shoot to be grafted; the shoot is bent inwards, bow fashion, when, after slightly raising the bark on each side of the incision with the blade of the knife, when the lips of the incised bark will open slightly and a bud such as has been described is cut and slipped in. The shoot is then left to spring back as it was before bending, and the scion-bud is compressed between the bark and the growing wood of the stock. A ligature of wool or rafia is then tied round, or a strip of waxed calico wrapped round the wound. In a couple of weeks' time the ligature is removed, and if the bud has taken, it is either forced to grow, if early in the season, by pinching the shoots of the stock directly after budding, and reducing them further a fortnight later, and finally cutting them above the bud, or it may, on the other hand, be allowed to remain dormant until next spring.

The main objection to this method of budding is the difficulty of selecting the right sort of scion-bud, and for this reason the next method is preferred.

#### VOUZOU BUD

is in many respects similar to the one described as suitable for fruit-trees and presents a striking analogy with the Yema or Summer Bud already described. It can be performed all through the growing season, and preferably in January and February. One point worth noting is that when detaching the bud, and previously to inserting it in the T-shaped incision, the veneer of wood which is cut off with the bud is not picked out and it is even desirable to cut deep enough to just reach the pith. A section of one-third to one-fourth of the node bearing a solitary bud gives good results. A fortnight after the bud has taken the canes of the stock are shortened to insure knitting and shooting of the bud. The ties, however, are not removed until a month after budding. This method is simple, gives a high percentage of strikes; good knitting can be performed on a stump of any age and on more canes than one, and if it can be renewed during the same season on some other joint, in case of non-success.

For early spring budding, cuttings from the previous season's growth are buried in the cool moist sand to retard their growth,

and they are inserted directly the sap is in full flow and the bark easily lifted from the wood.

Whichever method of budding the vine is used, it is desirable to fasten the tender young shoots to a stake as they grow in length, as they are very easily disjointed when young.

*See New Methods of Grafting and Budding.*—Dubois and Wilkinson, p. 12.

## PRUNING.

Several objects are aimed at when pruning. It helps to control the growth of the plant and train it in such a way that the operations of cultivation, of treating and dressing the trees and vines whenever required, and of gathering the fruit, are made easier and less costly. It equalises the wood and fruit production of the tree, checking the one to favour the other if need be, suppressing rank growth of the boughs, or limiting the productiveness of the plant in such a way that the quality is not affected by the excessive quantity of the fruit crop. Pruning aims at producing on the smallest area of a growing plant the largest amount of marketable fruit.

It checks the growth of suckers, water sprouts, and unsightly knobs and enlargements along the stem and branches; it tends to keep the plant in a thriving and healthy condition, promoting the growth of luxuriant foliage which tend to shelter the fruit and limbs from sunburn.

## PRUNING OUTFIT.

The tools required for pruning are few, but it is essential that they should be of the best quality and of a type suitable for the work to be done. It is also essential that they should be kept in good order, sharp and smooth, as a jagged or blunt blade will inflict upon the wood bruises and injuries which will either cause the sap to sour and the limb to die back or will delay the healing of the wound, and thus leave a door open to the entrance of the fungi of canker and other moulds productive of rot and decay.

*Secateurs*, or pruning shears, are easier to handle than the pruning knife. They do the work quickly, neatly, and without giving a jerk to the branches of trees and vines as does the pruning knife.

The plate illustration represents Rieser's *Secateur*, which can be procured in Perth. It is sold with a duplicate blade, made of

well tempered steel; the prong is made of chilled steel; the tool is nine inches long, strongly made and well finished.

The second illustration shows two types of secateurs and a handy pruning saw. The longer pruning shears, 15 to 17 inches long, is a two-handed one, and a very powerful tool, suitable for pruning strong vines and hard and knotty wood. One of its handles is chisel-shaped, and is found very convenient for suckering vines or trees, an operation which, when made with the blade, jags its edge and makes it blunt.

The edge of the blade of the secateur should be kept sharp by the use, whenever required, of a small hone or an oil stone, while the file will keep the teeth of the pruning saw set and sharp.

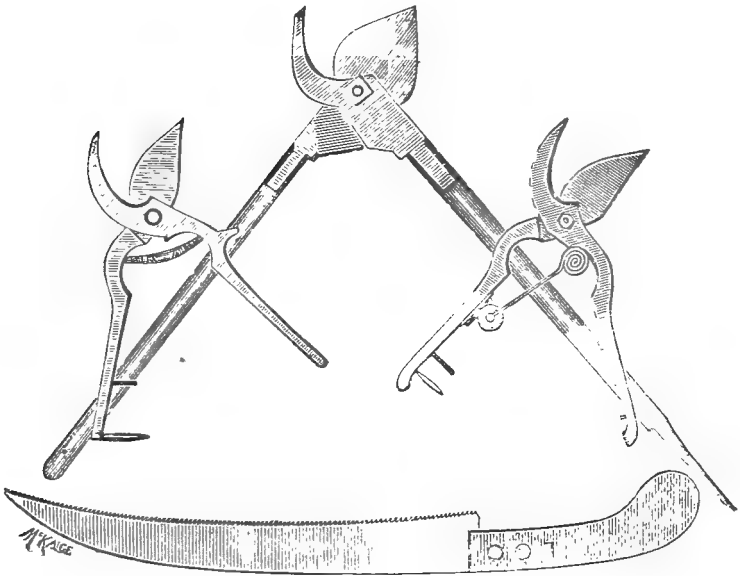

Pruning Tools.

When using the secateurs a clean and neat cut is given by seeing that the blade, and not the prong, faces the part of the wood which is left on the plant. As strong branches as can well be inserted between the blade and the prong can with little effort be snapped by gently pushing the top part of the branch or rod it is

intended to cut away from the operator and against the prong side of the secateur.

The *pruning knife* previously illustrated in the chapter on grafting, if kept sharp, will, in the hands of an experienced pruner, do very good work, and makes a very clean cut which soon heals over. The blade should be strongly made, of the best steel, and with a beak curved at a sharp angle. A rough buckhorn handle will ensure a good grasp in the hand while in use; the blade, well ground, will be found useful for trimming and paring the wound, and giving it a smooth face after sawing.

A *pruning saw* is also required, of which one type particularly suitable for sawing off arms of old vines is shown in the figure attached. Other suitable models are the bow saws illustrated in the chapter on grafting, page 92.

An *orchard ladder*, properly constructed, is a very handy appliance when puning trees and gathering fruit.

Orchard ladders of several designs are made. Some consist of a pole of a fibrous kind of timber, such as stringy-bark, bound with a strong band of hoop-iron a foot or so from the top end; this will prevent the pole, which is sawn to that point, splitting when the two lower ends are stretched and the rungs fastened.

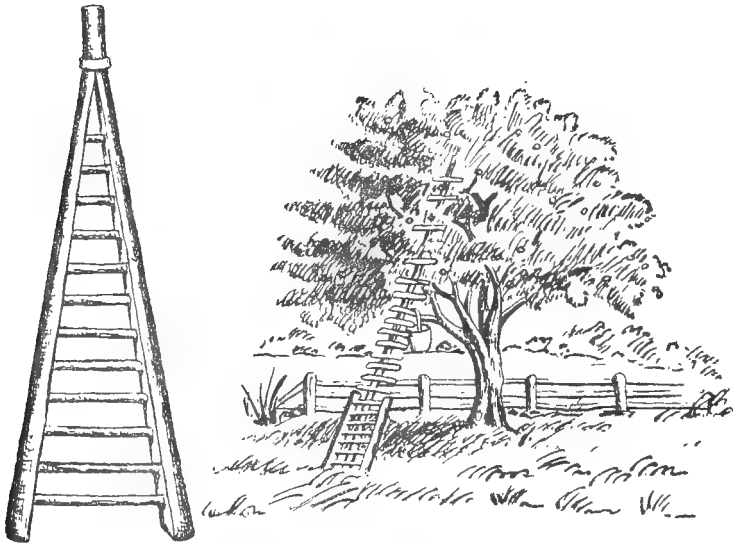

Fruit Ladder.



Hinged, four-footed step-ladders, like the one here illustrated, are, as a rule, clumsy appliances, which are inconvenient on hill-side or uneven ground, beside being heavy and easily dislocated. Those found ready-made for sale in shops are often so lightly made as to be of little use in the orchard.

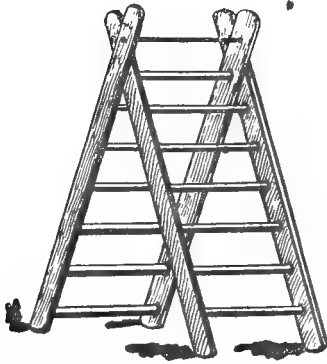

An Undesirable Fruit Ladder.

*Healing cover.*—Varnish or wax paper is found useful for preventing wounds, caused by the removal of a large limb, cracking and decaying owing to exposure; it also promotes a more speedy healing. For that purpose gum shellac is often used. It is made by dissolving in a little strong alcohol as much gum shellac as will make the varnish of the consistency of paint. This varnish is

kept in a well-corked flask, with a mouth wide enough to admit a brush, and is thus always ready for use. It is applied over the cut surface, well pared with the knife. Other good coverings for wounds made in pruning are also common white lead paint, grafting wax, coal tar, in the order named. The last named is often a hindrance, while pine tar is even somewhat detrimental to healing.

#### CUTTING TO A BUD.

It is important before cutting off a branch of a tree or a rod of a vine to make sure that the last bud left on the plant, and which is intended to prolong the growth of the plant, is a sound, plump one, likely to grow, or whether it has accidentally been rubbed off or otherwise destroyed. Such a terminal bud should be a leaf bud, and not a fruit bud.

*Leaf buds* differ from fruit buds in being more elongated, flattened, and more pointed in the same species of plants; they are either single, or give growth to single shoots, or double and even triple, when grouped in small clusters, two or three together, as in the case of stone fruits, they produce either leaves or branches.

*Fruit buds* are distinguished from leaf buds by their rounder and fuller form, the scales that cover them are broader, and they begin to swell and burst open earlier in the Spring.

Fruit buds are also single, as in the case of apples, pears, quinces, or single, double and triple, as in stone fruits and berries. They are, besides, simple or compound; that is to say they produce

but one flower, as in the peach, nectarine, almond, and apricot, or two or more flowers, in clusters, as in apples, pears, plums, and cherries.

All buds are leaf buds when first formed; some at a later stage develop, either by being allowed to mature naturally or by artificial means, into fruit buds. Many trees develop their fruit buds towards their terminal shoots, unless these are cut off, when those left at the base of the branch, or along it, being thus excited into growth, are transformed into lateral fruit buds.

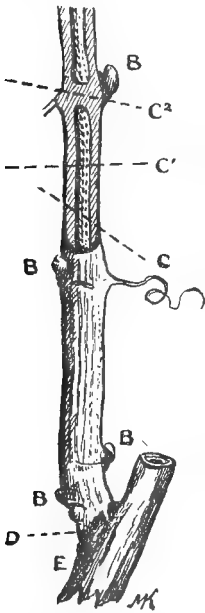

Section of Vine Cutting showing Diaphragm and Pith.

When cutting to a bud a slight slant is generally given to the cut, at a place close to the bud, although in so doing it is advisable not to approach the bud too closely, nor on the other hand leave above it a useless stump, which might engender decay; a piece of wood about an eighth of an inch above the bud is sufficient to leave. In the case of the grape vine the practice is often to cut through the joint, above the last bud it is intended to leave on the spur, as shown at  $C^2$ . A longitudinal section of the young wood of a vine shows in each joint a tubular cavity filled with pith; at each joint or node that tube is closed, as in the case of the bamboo, and if the section is made at  $C^1$  that pith dries up and the bud below is at times endangered.

The section should be made either at  $C$  or at  $C^2$  as shown on the figure, and never at  $C^1$ . The buds  $B$  are those left on the spur.  $D$  is an axillary bud which often fails to shoot.  $E$  is a piece of the previous season's wood.

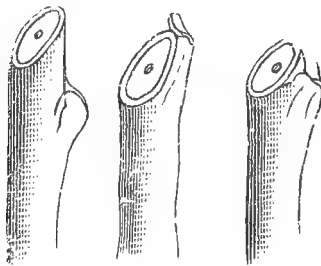

Cutting to a bud: (1) too long; (2) too close; (3) right way.

## WHEN BEST TO PRUNE.

For the winter pruning of deciduous trees June, July, and August, and in late sorts as late as the middle of September, are the best months. Pruning may be started directly the wood is ripe, when the leaves fade and begin to drop off. It is recommended to give to apricots and cherries a preliminary pruning in the late summer, after the crop has been gathered. Trees thus pruned are less subject to gumming and dying back, and the leaf buds have thus more time to transform into fruit buds, and to perfect themselves. Varieties which shed their fruit often become more fruitful by being thus treated.

As a rule older trees are ready for pruning before younger ones.

In frosty localities, where stagnant, cold air hangs about hollows and gullies, it is advisable to delay the pruning of vines, peaches, and plants whose sap moves early, until later in the season. This delays the period of active growth, and may save the crop, ensuring a better setting, and also in some seasons warding off the early attack of the Black Spot or Anthracnose. As regards the grape vine, later pruning is, if anything, also preferable to early pruning, in respect to yield of the crop and earliness of the period of maturity; but, of course, where wide areas have to be gone through it is not possible to delay until the right moment, this operation.

Summer pruning, on the other hand, is done when the tree is in active growth, as will be explained in a further chapter.

## VINE PRUNING.

## PRUNING AT TIME OF TRANSPLANTING.

In Western Australia, where the summer season is dry and protracted, rooted vines are more in favour than cuttings when planting a vineyard. The figure below shows how a typical rooted vine from the nursery bed is cut back prior to planting. The bruised roots are trimmed off, as shown at C, as well also as those fibrous roots along the stems: these, were they allowed to grow, would be too close to the surface, and would in the long, dry summer fail to maintain through the plant the requisite flow of the nourishing sap. If the rootlings are planted with a dibble in deeply prepared ground that has previously been manured, the roots may be cut back to stubs half an inch long. They will develop a deeper and stronger root system than vines with long roots set in holes dug in more shallow ploughed soil. Two good buds

only are left on the rooted plant to supply the wood and the foliage which the vine will carry the first season of its growth.



Trimming rooted vine before planting.

#### PRUNING FOR WOOD AND FOR FRUIT.

Excessive wood growth is detrimental to heavy bearing, but, on the other hand, excessive bearing checks the growth of the plant. The art of pruning consists, in a great measure, in so balancing the bearing and the growing vigour of the plant that regular average crops are borne annually of good-sized, well-nourished and healthy fruit.

The shoot from a bud is generally considered good for two bunches of grapes, and a good-sized vine growing under favourable conditions out in the field may be allowed from one to three dozen buds. These should be uniformly distributed, according to the system of training adopted, as symmetrically as possible over the vine, the stronger arms being allowed, according to their vigour,

more buds than the weaker ones. Sturdy vines trained on overhead trellis may be allowed as many as eighty buds, and even more in particular circumstances.

In connection with the pruning of the grape vine there are several facts which should be borne in mind.

The vine bears on wood of the present season's growth, issuing from a bud on wood produced the preceding year.

The activity of the sap is much greater in those shoots which grow more erect than on those which are bent down or are trained horizontally; it is also greater towards the extremity of a cane than towards its base.

A bend or a twist to a cane which has a tendency to shoot upwards will, while checking that tendency to excessive wood growth, favour its productiveness.

Only leave matured wood, of medium size, and short jointed, in preference to either luxuriant "bull canes" or spindley stunted growths with a weak constitution.

A vine with a tendency to "go to wood" should be pruned for fruit, by resorting to either long or to mixed pruning. If, on the other hand, a vine shows signs of exhaustion and does not make a fair amount of wood, it should be severely pruned so as to reduce the number of the fruit-bearing buds.

"Suckers" and "water shoots" should be cut clean out, unless required for renewing the top of the vine, or part of it; these shoots are, as a rule, sterile the first season after they come out. When cut back the growth issuing from them carries fruit sparingly the first year.

#### PRUNING YOUNG VINES.

The aim of the pruner is to form a stem on which to build the framework which will carry the future crop of grapes. The year of planting the growth of the young vine is not interfered with. The subsequent season all the canes but one are cut off, and this cut back either to a height of six to nine inches if it is intended to train the vine gooseberry-bush fashion, or to a height of 14 to 15 inches if it is meant to train it on a trellis. If a suitable cane is not procurable, cut the young vine hard back to two buds and train the strongest shoot which will spring from one of these buds erect to a stick or a piece of bamboo set into the ground.



Forming young vine.

#### STAKING.

After the first winter pruning the vines should be staked, whether they be intended to be trained bush-fashion or on trellis.

For the former use stakes about 30 inches long, driven about 15 inches into the ground; if the vines are to be trellised the stakes are a few inches longer. They should be made of  $1\frac{1}{4}$  in. to  $1\frac{1}{2}$  in.

wood, and are driven one or two inches from the vine on the side below the prevailing wind. This offers a support to the vine and reduces the strain on the tying string.

#### STRUCTURE OF THE BUDS.

Some knowledge of the nature of the buds of the grape vine will help in understanding the reason for long or for short pruning.

Two kinds of buds are found on a vine cane. At the base, axillary buds, or in some sorts, half-developed buds occur, which, if cut in two with a sharp knife and examined under a microscope, would show a core surrounded with scale. These buds are unfertile, and, if they grow at all in the spring, they form wood shoots.

Higher up the cane, and the farther away from the base, the buds become more fertile; a section of such buds show, around the core, microscopic grape bunches and tendrils. They represent, in embryo, the coming season's crop. If, by some agency or other, either wind, frost, or accident, the shoots issuing from them are destroyed, fresh shoots are often produced, which are produced by less developed secondary buds, and the crop will, in consequence, be reduced. It is thus seen why some vines fail to bear fruit if they are pruned too short, and others overbear if too much wood is left on them.

When it is admitted that the coming crop is present in embryo on the vine at the time of pruning, it is easy to understand how a droughty season, or blights of some sort or other, by weakening the vine and stunting its growth, is not only detrimental to the visible crop, but also affect the next season's crop as well.

#### SYSTEMS OF PRUNING.

"Pruning" and "training" differ, insomuch as pruning affects the growth and productiveness of the vine, and the quality as well as the quantity of the grapes; whereas training is purely conventional, and does not affect growth and fruitfulness to the same extent. Training varies according to locality and to circumstances, and it is simply adopted for the sake of uniformity, and to facilitate cultivation, dressing the vines, and gathering the grapes.

Pruning leaves on the vine: spurs or spurs and rods in combination.

A "spur" consists of the basal portion of a cane made up of two full internodes or joints. This leaves two buds besides the basal bud. The strength and thickness of the cane from which the spur is made govern the number of buds. A thin and weak bud should be cut back to one bud, or even the base bud. A strong cane, on the other hand, can be left with three buds besides the basal bud.

The methods of training are numerous and varied; the several systems of pruning, on the other hand, may be cut down to three main types, according to the length of spurs or of fruiting canes left on the vines, viz., *short*, *long*, and *mixed pruning*.

*Short, or Spur Pruning*, consists in leaving on the vines short spurs of one to three buds only—generally two buds. It is applicable to those vines of moderate growth, which fruit most readily from every joint of their fruiting wood. Although the crops are thereby reduced, and the bunches fewer in number, they are, in consequence, of larger size and more showy.

*Long Pruning* consists in cutting long one or more of the previous season's fruiting canes. Six to ten buds are left on the canes or rods of these varieties, which only bear fruit on buds situated farther away from the crown or the arm, the lower buds being mostly sterile, or not regularly fertile. Should such varieties be pruned short, most of the fruitful buds would be removed, and the result would probably be a luxuriant wood and leaf growth, and a very small crop.

*Mixed, or Half-long Pruning*.—Between these two systems is an intermediate one found useful in the case of vines which have been pruned short, and are planted on rich ground, and run into rank growth at the expense of fruit production. It is also useful in the case of vines which, of the class that is pruned long, fail through exhaustion and lack of necessary vitality, to carry a full crop of well developed grapes.

As the illustration shows, it is advisable to leave for each longer cane a short spur cut back to two buds, whose duty it is to provide wood for the following year. When that pruning comes the longer canes now illustrated are cut off, and a new fruiting cane, together with a shorter wood spur, are selected from the shoots issuing from the wood spur shown in the figure.

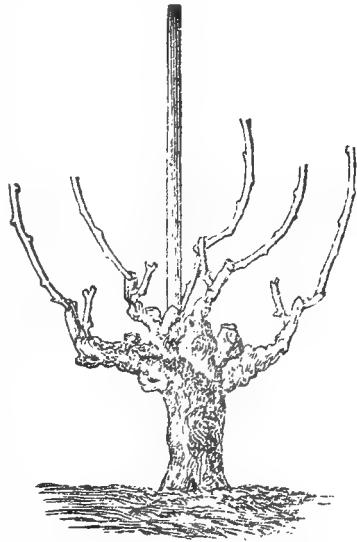

Mixed or half-long pruned vine.

#### GRAPE VINES GROWN IN WESTERN AUSTRALIA.

##### *How to prune them.*

The following list supplies the names of vines which in fairly moist and fertile localities are better pruned short or long, as the case may be. In dry districts, however, it is preferable to be sparing of long pruning and high training, and to adhere more closely to short pruning and low bush training. This insures a more rapid and freer circulation of the sap, and consequently better

nourished bunches. In such localities it may be advisable to make up for the low fertility of the basal buds of the canes by multiplying the number of spurs.

*Prune short*: Alicante, Aramon, Aspiran, Black Hamburg, Belas Blanco, Black Malaga, Carignane, Chasselas, Cinsault (Oeillade, Blue Imperial, or Grand Turk), Clairette, Cornichon, Currants, Dolcetto, Doradillo, Duke of Buccleugh, Early Green, Frontignan, Folle Blanche, Gamay, Gouais, Grenache, Lady's Finger, Mataro, Morastel, the Muscats (one or two buds only), Pedro Ximenes, Palomino Blanco, Red Prince, Royal Ascot, Semillon, Santa Paula, Sweetwater, Trebbiano, Verdelho, Wortley Hall, Zante Currant (when cinctured), Zinfandel.

*Prune long*: Cabernet, Centennial, Crystal, Cornelian (Quick's Seedling), Early White Malvasia (Lignan), Gros Colman, Malbec, Merlot, Ohanez (Almeria), Pinot, Raisin des Dames, Riesling, Roussanne (White Hermitage), Sauvignon Blanc, Shiraz, Sultana, Tokay (Green Hungarian), Verdot, Verdelho.

*Prune half-long*: Any of the above sorts if not growing very strongly, and more particularly, Black Prince, Frontignan, Malaga (black and red), Currants, Chasselas, Red Muscatel, Waltham Cross.

#### METHODS OF TRAINING.

As I have already pointed out, training is merely a matter of convenience. The numerous methods followed may be reduced and grouped under two types:

1. Vines growing upright, with or without stalks
2. Vines trained on horizontal wires or trellises.

*First Group: Vines trained upright.*—To this group belong the Gooseberry Bush, or "Goblet" shape vines, trained according to this method, and of the class that require short pruning. The single stem, sturdy and straight, having been formed, a fork of



Bush vine after second pruning. (Foex.)



Bush vine after pruning. (Foex.)



two spurs, with two buds on each, is left when pruning the second year; these will constitute the first two arms of the vine; the subsequent season one or two spurs are left on these arms, and so on until the number of spurs is increased to six or eight in the case of a strong vine. When well-shaped the vines need not stand in the way of the horse implements, and when the arms become too long advantage is taken of the presence of any water shoot conveniently situated closer to the stem. This shoot is at pruning time cut back to two buds, and turned into a spur to fill the gap of the longer and older arms, which can then without inconvenience be sawn off or cut hard back.

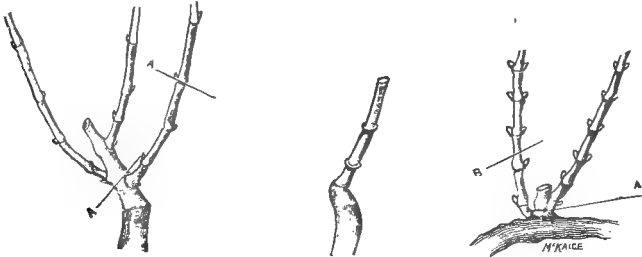

#### SPUR PRUNING

A.A. shows the points of section and spur left after pruning. Method of pruning wood growing on a short spur, set on a permanent arm. A. and B. show where to cut. (Foex.)

To this group also belong vines pruned half-long and trained goblet shape.

The heavy initial cost of staking or trellising a vineyard planted with sorts requiring long pruning at times makes it convenient to train vines without support.

The wood-cut alongside illustrates this method of training. One or more long rods, consisting of six to ten eyes (C), with a short wood spur of two eyes at the base of each (S), are for this purpose left on the vine, the end of the rods being either bent down and tied to the base of the opposite rod, or the rods are made to entwine together in the form of a bow.

It is customary to leave the long rod above the short wood spur, which is closer to the stem, to keep the arms of the vine from rising too rapidly, as the long rods being cut off the subsequent pruning, the wood necessary to continue that method of pruning is found supplied by last season's short spurs.

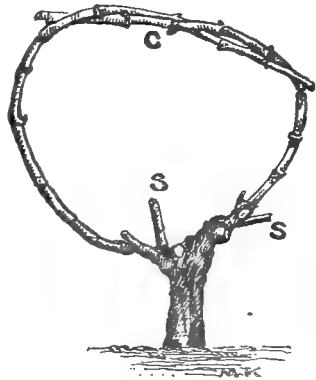

Long rods and short spurs.

*Second Group: Trellised Vines.*—Vines trained on trellises are pruned either with short spurs along permanent arms, or with long fruiting rods. In France, vines trained on wires, with an arm on each side of the stem, are said to be trained *espalier* fashion, in contradistinction to those trained *cordon* fashion, with one main arm only bent on one side of the stem.

The adjoining figure represents the *Guyot cordon* and the double *Guyot*, or *Bordeaux Espalier*, is represented below. They are limited to those vines which have their fertile buds away from the base of the canes, or those whose basal buds are not regularly fertile.

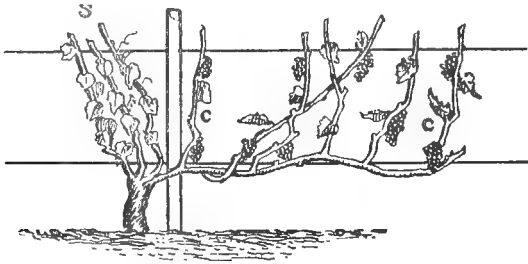

Guyot Cordon before pruning.

The *Guyot cordon* consists of a long fruiting cane (*c*), about three or four feet long, and a short wood spur (*s*) cut back to two buds, which is intended to provide the wood necessary for the subsequent season's pruning.

When that time comes the cane (*c*) is cut clean off, one of the canes shooting from *s* is tied down in its stead, and another cane from *s* likewise is cut back to two good eyes—the axillary buds not being counted.

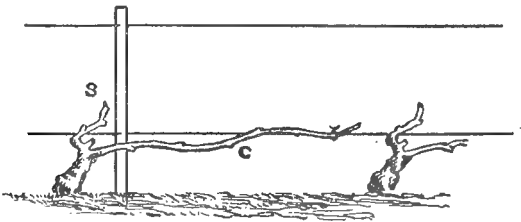

Guyot Cordon after pruning—Rod and Spur.

This method of pruning and training, which is suitable for weakly vines of the *Pinot* tribe, growing on the poor limestone of

a cool country, where it is much in favour, is not to be recommended for richer soil under a forcing climate like that of Western Australia.

A modification of it, and one better suited to our local conditions, with vines like the Cabernet, Malbec and Riesling, is a modification of the Guyot system, known as the Bordelais espalier, which

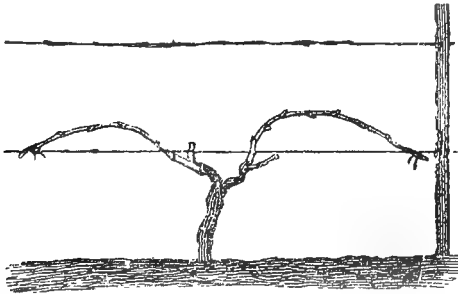

Bordeaux Espalier. Combination of Rod and Spear.

is correctly represented in the accompanying figure. It gives more scope to the vine, and should it be found necessary to give even

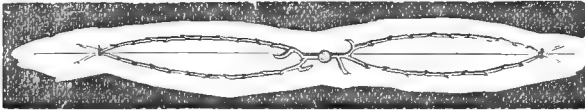

Bordeaux Espalier.—Vigorous vine, with two long fruiting rods and short wood spurs on each side of the stem.

more wood to particularly luxuriant vines growing on rich, deep soil, two new rods may be left.

These vines are formed thus: The first pruning is in every way similar to the one already described. The trellis is made of two wires, the first 16 to 18 inches from the ground, and the second 20 to 22 inches above it. It is advisable to train the stem along a short stake for a year or two, so as to better keep it straight. The second year the stem is pruned to a height of 12 to 14 inches, or it may be cut back about the height of the lower wire, the blade of the secateur being made to cut through the top node; this stem can then be tied firmly to the first wire and staking thus dispensed with. From the joints below, shoots will grow, two of which at the time of the third year's pruning will be cut back to two buds only. The shoots from these short spurs will be trained as represented, one horizontally on each side of the stem and along the bottom wire,

while the other shoots from these spurs will be cut back to two buds to provide wood and fruiting canes for future pruning. It is important that all shoots not required should be rubbed off as they appear on the stem.

## 2. PERMANENT ARMS AND SHORT SPURS.

This method of pruning and training is typically represented by the *Thomery espalier*, named after the favourite method of pruning followed by the vinegrowers of the fertile village of Thomery, near Paris. It is one well adapted to our local requirements.

It consists of two main arms set horizontally on each side of the stem along the lower wire. Along those permanent arms spurs are left at intervals of nine to ten inches. The interval between the first spur on each permanent arm is 12 inches or a little more. It is essential, more particularly in the case of trellised vines, that there should be one stem only to each vine; in the case of the *Thomery espalier* it is important that the right and the left arms should start as nearly as possible from the same level, so as to better equalise the flow of sap and avoid wide blanks being created and much of the space available over costly trellises remaining idle. To guard against this the arms should be encouraged to spring from the stem at about the same level and they should be trained sharply along the first wire, thus giving to the vine the form of the letter T. For this purpose, as soon as the stem has grown three or four joints above the lower wire it is pinched just above the bud which is level or is nearest to that wire; this is done sometimes in the summer. From the end of this still tender shoot another small shoot will grow, and this is also pinched back, generally when it is one or two inches long. The vine being still in full growth, another shoot will soon appear from that terminal bud which has been strengthened by this process of pinching back. This shoot is allowed to grow; it carries at its base a cluster or two, or it may be more, buds. At pruning time, when mature, cut back to the point (*a*) indicated on the figure. From these shoots will grow, the stronger two of which are bent down, directly they cease to be brittle, to the wires, where they are fastened.

Before the end of the season, and when they are a foot or two long, these horizontal shoots are pinched back, with the result that they will throw up laterals which will form the bases of the spurs the following season. It is not advisable to give to the permanent arms their full length the first year, but it is preferable to add a few joints to the arms every year until the space from vine to vine

along the lines has been filled up. This is done by always pruning to a lower bud the last joint left on the vine, and from this lower bud will grow a shoot which will naturally take a horizontal direction. An upper bud would probably throw up a shoot which would have to be bent down and would show by a kink the interruption in the growth of the arm. Once the spurs are established they are cut every year to two buds, as has already been explained.

### 3. PERMANENT ARMS—MIXED OR HALF-LONG PRUNING.

An example of this method of pruning is the *Cazenave cordon*. The only advantage it possesses over the Thomery espalier is that, being one-sided, there is no occasion to use when pruning the amount of discrimination necessary when training a vine espalier fashion, in which case the proper equilibrium of the plant is maintained or re-established by keeping the two arms in the same state of vigorous growth, if they are of equal development, or by favouring the growth of the weaker arm by hard pruning if found necessary so to do. Although the figure does not show it, three wires are better than two in training vines according to this method. If the distance from vine to vine is too great, the cordon is not all laid down at once, but half of it may be trained first, the cane being cut to a lower bud, which will produce a straight horizontal shoot which will be utilised for lengthening the cordon.

The permanent arm is made to grow spurs, which each produce a fruiting cane and a wood spur. It takes four seasons to properly form a Cazenave cordon.

*Training Vines.*—A convenient method of training on wire, which obviates the necessity of tying the rods in the early summer, consists in using three wires. The first strained one inch or two inches above the crown; above this 15 to 16 inches and on the same level two wires are placed, stapled to opposite sides of the post. The growing shoots are merely pressed between these wires without tying.

Where tying is practised, New Zealand flax, bullrushes, or old twine is used. Rye straw is much used in France, and small plots are grown for that purpose.

### 4. PRUNING THE SULTANA (CAZENAVE PRUNING MODIFIED).

This is a very neat and very useful way of training vines requiring long pruning and growing on rich ground. It is thus seen

that once the framework of the vine is well formed it may be pruned with all the modifications of short, half-long, or long pruning already described.

This mixed system of pruning, which finds favour with some, is suitable for localities where both soil and climate are favourable to a luxuriant growth of the vine.

It is particularly suited to the Sultana, and on rich soil to the Zante Currant.

The Sultana bears well only on long canes, the short spurs providing wood for the next pruning. In the Swan valley the Bordeaux espalier with short arms, bearing two long rods and two spurs

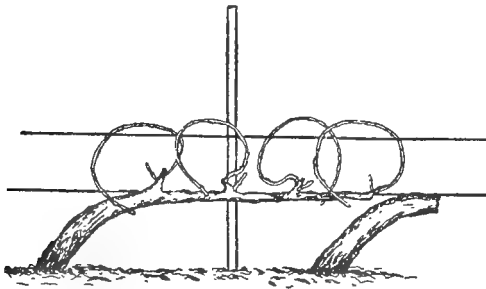

Cazenave Cordon modified. Permanent arms and long bent rods with short spurs. (Bioletti.)

each, are satisfactory. Repeated suckering and removal of water sprouts are required to insure a strong growth of replacing canes on the wood spurs. The cracking of the joints with the fingers and the curving of the fruit canes or rods promotes the starting of more shoots or of the consequent production of more bunches of grapes. At the same time the buds on the wood spurs are forced to start; these, not being shaded, tend to grow vigorously. It is advisable to tie these in a vertical position to the top wire of the trellis; and they should not be topped.

It is essential, to obtain good results with the sultana, to go over the vines at least twice during the spring and rub off suckers and water shoots not required to replace the fruiting wood at the next winter pruning; these are generally sterile, grow vigorously, and, unless removed, rob the fruit shoots. This disbudding should only be done a week or two before blossoming, and next after the flowers have set.



Short-pruned Zante Currants.



Pruning the Sultana.





## GARDEN TRELLISES.

Perhaps nowhere is the want of systematic training and pruning of the vine more glaringly exhibited than on the private garden trellises. The second of the two accompanying illustrations forcibly exhibits such amateurish method of training and pruning vines. There the vines are allowed to grow without restraint, and at pruning time canes are bent and directed in the most fanciful manner to fill a gap here and there. These vines, which are generally grown in close proximity to the house, as a rule receive more attention: they are manured, sulphured, the ground is dug round them, and as they bear well the owner takes little or no trouble in the first years of their growth to train them with some sort of method, until with years his mistakes are made apparent to him. The lower buds are robbed by the higher ones, they get feebler and feebler, and at last cease to grow at all; the sides of the trellis become denuded, and all the energy of the vines is spent on the top. The sketch printed in these pages illustrates a method of training vines on the home trellis which, if copied, will result in the owner deriving from his vines both shelter and fruit. The sketch is drawn to scale, the vines planted six feet apart, and trained with one permanent arm only. On that arm, at intervals of 10 to 12 inches, spurs are left and cut back to two eyes, unless the vine shows a tendency of running riot, in which case one of the methods of pruning reviewed in a previous chapter on pruning, and preferably the modified Cazenave method, may be adopted. This method consists in leaving on the permanent arms one or several long rods supplied with five to ten

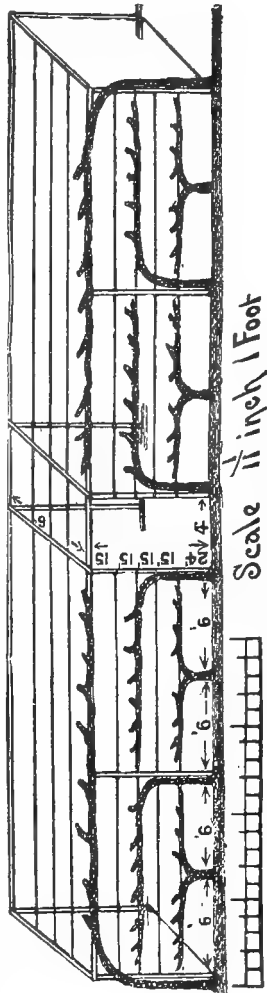

Training Vines on the Garden Trellis.

eyes. These rods are bent down and tied; they carry much fruit and supply an outlet for any excessive flow of sap from the vine.

#### T-HEAD TRELLISING FOR CURRANT VINES.

Unless adequate development is given the currant vine, it often remains infertile. The following method of training these vines, which has for a number of years been adopted with marked success by Mr. Thomas Hardy, of South Australia, is found to be suited to those vines:—

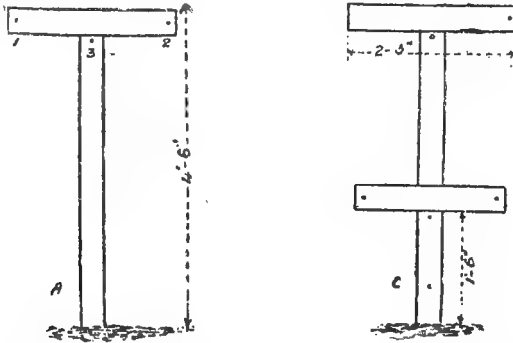

The vines are planted 10 feet in the rows, which are 12 feet apart. Posts,  $4\frac{1}{2}$  feet out of the ground, are set every 30 feet.

Cross-heads 27 inches long, made of split wood 2 inches x 4 inches, are bolted on at the top of the posts. Lower cross-heads a little shorter, about 24 inches long, may also be bolted at a lower level, say 18 inches from the ground. Three wires for each tier are used, the middle one slightly lower than the outer ones. The end posts are well strutted; No. 8 is used for the central wire and No. 10 for the outer wires.

The currant vines are trained alternately on the top and bottom tier, and thus more room is afforded for their development. The vines may either be trained right and left, T fashion, or with one single bent arm like an inverted L. The main arm is trained up along the middle wire (3), the long rods (a) being tied alternately to the outer wires, any buds beyond the wire being cut off. The short spurs (b) usually bear as much fruit as the long rods.

For this trellis, however, is generally substituted the two-wire trellis found in most vineyards, with the first wire 18 to 20 inches from the ground and the second wire 18 to 20 inches higher. Should the currants be particularly strong a third wire another 18 inches higher may be added as shown in the figure below. Spur pruning gives more sugary and more fleshy currants.

On average vine land the currant is spur-pruned along permanent arms, while on richer land the spur and rod system answers

well, provided the currant vines are cinctured at blossoming time or just after, between the base of the arm and the first spurs. This is done by running a knife on the stem twice round and cutting the bark and the inner bark, thus checking the return flow of the sap and causing better setting of the currants. The two cuts are made at an interval of one-sixteenth to one-eighth of an inch, and no ill effect results from this yearly treatment, which was first introduced to the notice of Australian growers by Mr. W. C. Grasby, who had seen it practised in Greece. Young vines cinctured too early may suffer a setback, and the operation should therefore be postponed until the plant is strong and is growing vigorously.

#### COST OF STAKING AND TRELLISING.

The cost of trellising currant vines according to the above method, recommended by Mr. Thomas Hardy, if done in a substantial manner, is in any case a heavy one, and to do it in any other way is false economy. The figures given below would vary somewhat with the cost of posts and of wire.

For one acre of vines it will take:—

	£	s.	d.
118 posts at 6d. each	...	...	2 19 0
11 straining posts at 1s.	...	...	0 11 0
11 struts at 6d.	...	...	0 5 6
123 crossheads at 10s. per 100	...	...	0 12 3
5½cwt. of wire at 10s.	...	...	2 12 6
30lbs. bolts at 3d.	...	...	0 7 6
Labour erecting	...	...	3 1 6
If two tiers, extra	...	...	4 10 6
			£14 19 3

This price would now be much higher on account of the advance in the cost of wire, labour, etc. A cheaper style of trellis is now used in currant vineyards and consists of two wires only, a third wire being added on rich land and where the vines grow more luxuriantly.

#### STAKING AND TRELLISING VINES.

A great many vine-growers are deterred from staking or trellising their vineyards on account of the somewhat heavy expenditure of money it entails. Instead, therefore, of pruning such vines long, as require long pruning, they spur prune them, with the result that the crop the vineyard is capable of producing is materially lessened.

If a given area of vineyard can, at a comparatively small additional expense, be made to yield a heavier crop, the returns will be equivalent to those of a larger area. For instance, if by spending an additional £8 to £10 per acre the net profits are increased by 30 per cent., the result is equivalent to increasing the

area under cultivation by one-third, and that at a cost much below that which such addition would involve. An acre of vineyard, for instance, worth, say, £50, would be practically, by the extra expenditure of £10 for staking or trellising, be made to yield a return of one acre and one-third, and represent a capital value of £80.

For stakes, the sizes generally used are 2 x 2 inches, 6ft. long.

In different places the cost of material would vary; the cost of purchasing, hauling, sharpening, and setting good jarrah or raspberry jam stakes would be generally about £10 a thousand vines, or about £6 5s. an acre for vines planted 8ft. square.

In trellising, 6ft. posts 3in. x 4in. are used 2ft. below and 4ft. above ground, and at the end of the rows straining posts 6in. x 3in. and 6ft. to 6ft. 6in. long. Two wires only are necessary, viz., near the coast No. 10 galvanised wire, and inland, where the corrosive action of the air is felt to a lesser degree, the cheaper No. 10 black steel wire will answer.

The first wire is set at a height of 18 inches from the ground; the second wire 20 to 24 inches higher, or about 3ft. to 3ft. 6in. from the ground.

The following is a pre-war estimate of what the cost of trellising a 10-acre vineyard would probably be at per acre. Supposing the block of vineyard measures 10 chains x 10 chains and the distance between the rows is 10ft., there would be per acre  $6\frac{1}{2}$  rows, requiring:—

	£	s.	d.
13 straining posts per acre, at 9d. each ...	0	9	9
165 ordinary posts, 28ft. apart, at 25s. per 100	2	12	0
165 holes for same, at 5s. per 100 ...	0	9	0
4cwt. galvanised No. 10 wire, at 12s. 3d....	3	0	0
Boring holes, putting up, and straining ...	1	0	0
	<hr/>		
	£7	10	9
	<hr/>		

#### BURNING THE CUTTINGS.

When the pruning of the vines or fruit-trees is done the cut canes or wood are picked and burned. The most expeditious way of effecting this, if the area is of any size, is to secure a rejected 300 or 400 gallon square iron tank, which may be bolted on iron brackets on two wooden beams 5in. x 3in., which act as a sledge. This is dragged by means of long chains. The side of the tank that is on top is cut off with a chisel and the man-hole and other apertures are made at the bottom between the wooden sledges, which act as a grating to provide a draught and facilitate the dropping of the burnt ashes. The front of the wooden beams are cut bevel to cause the sledge to slide over the surface of the ground. Into this tank a fire is lit, and as the horse drags the furnace along the rows a couple of men throw the wood into it. In this way a number of pests are destroyed, the ashes are spread evenly over the ground,

and the cost is greatly reduced for picking the cuttings, taking them out to the headland, and attending to the burning.

## FRUIT-TREE PRUNING.

In this chapter the shaping and the pruning of the several varieties of those temperate climate fruit-trees grown in our orchards will be more particularly referred to.

### GENERAL PRINCIPLES.

There are a few rules which are applicable in every circumstance, and which should be borne in mind whatever the system of training, or the kind of tree to be pruned, may be. When pruning, cut off all dead wood; also one of any two branches which may happen to cross and rub against each other, thus chafing the bark and injuring the limb. Suppress water shoots and suckers. When cutting to a bud do not leave a stump above the bud; but on the other hand do not cut the wood off too close to that bud. When compelled to remove large limbs, pare off the wound with a sharp knife and cover the wound with some dressing, such as already recommended in the previous chapter on pruning, or even with clay, which, while preventing the air and the dampness from drying and rotting the wood, will not prevent the young bark overgrowing the wound and gradually healing it. Before cutting a limb off try to see what the result of your action is likely to be a few years hence, and thus save at an early stage the possible necessity of having to cut large limbs at some future period.

Should it be found necessary to cut a large limb, saw it a short distance from the bottom first. Then saw down from above, and the limb can be removed without fear of splitting off below. Never cut a branch without having a reason for doing so. Under the climatic conditions which prevail here, it is better to err on the side of cutting hard back to keep the tree low, than on the side of sparing the tree the first years of its growth and letting it run up a high stem topped with long, lanky branches.

### SYSTEMS OF TRAINING AND SHAPING FRUIT-TREES.

Climatic conditions to a great extent influence the methods of training trees. Thus in colder climates they are often trained *Cordon* fashion, or in *Espaliers*. Then again the *Pyramid* shape was for a long time a favourite in warmer climates, until the *Low Standard* or *Vase* system supplanted it.

1. *Cordons*, which are either vertical or horizontal or oblique. Trees trained as horizontal cordons have their stems bent at right angles and fastened to a wire. These cordons are either single, as shown in the figure, or double, *i.e.*, with a branch on each side. Although this method of training trees is sometimes employed for

apple and pear trees in cold countries, it is better adapted for vines, and as it is unsuited for this climate I shall dispense with describing the method of thus shaping trees.

2. *Espaliers*, a popular method of training apples, pears, apricots and peaches alongside walls in the Northern climate of Europe, where specimens of this system of shaping trees, illustrating the skill and handiwork of the European gardener, can be seen in public and private gardens. In warmer climates, this method of training has nothing to recommend itself, and needs no description.

The *pyramid* shape of training was, until not very long ago, when the low standard or "vase" system supplanted it, much in favour for trees grown in the open air in the cooler climates of England and Central Europe. It is more especially suitable for pears and cherries. This form of training takes at least five years to bring to perfection, and it often happens that, either before or after this work has been satisfactorily completed, a fierce gust of wind, a snow-storm, or some other unexpected accident, will destroy in one act the work of years of patient training. Trees trained pyramid shape require besides a good deal of ground to fully develop, and for the easy working of teams and implements; for this purpose the interval from tree to tree should be at least 30 feet. One advantage it presents over the "vase" system, which is next described, is that the limbs are well knit to the central stem, and not liable to split under the load of fruit. To sum up:

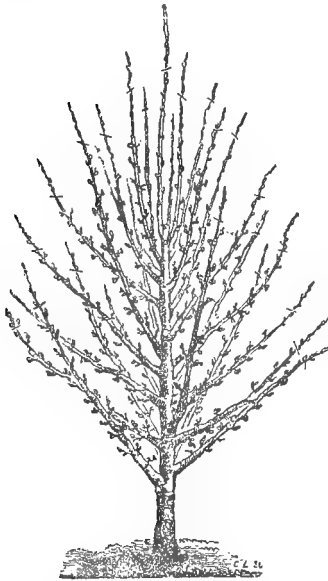

Pyramidal training of a Pear Tree.

Every variety of fruit-tree is not equally suited to this system of pruning; it takes too long to form, it occupies too much space, it is too high for pruning, spraying, and picking, and is too much exposed to winds.

4. The *low standard* or "vase" system has been found by long experience to be the form best suited to the Australian climate; it is also the one best adapted to Californian conditions. Unlike the pyramid shape, which has the cone pointing upwards, the "vase," "goblet," or "wine-glass" form, rests on its cone, and directs its







branches upwards and outwards. Amongst the advantages it offers it is simple to understand and master; it is applicable to all kinds of fruit-trees; it is suitable to all localities where fruit-trees can be grown out in the open without artificial shelter; it forms a vigorous stocky tree, well balanced, easier to prune, spray, and pick; it efficiently shelters the stem against sun-cald; it resists the onslaught of heavy gusts of wind better than the other forms of training; it requires less space than the pyramid form; it offers greater facility of approach to the stems by the horses when cultivating.

The above paragraph sets forth the advantages of this system in preference to others. The low standard system of training, however, best suited for the climatic conditions which obtain in countries like Australia and California, where hot summers prevail, has been materially modified from its prototype, the "vase" or "goblet" form, found in the gardens of Europe.

#### EUROPEAN VASE OR GOBLET.

There the tree is headed back to two or three feet; three or four branches disposed round the stem are drawn outwards by means of strings fastened to pegs, which will form the main limbs of the tree. On these limbs, which are cut back the next winter to a lower bud which will continue the main branch, and either to the left or the right of it, a side shoot is allowed to grow and all the other shoots are pinched back; these two shoots are bound to a light hoop to keep them in place, and constitute the main branches of the young tree. The next winter again this process is repeated, with this difference, that the side shoot is allowed to grow on the opposite side of the previous year's side shoot. These form secondary branches, and are fastened to larger hoops; all shoots which start to grow either inward towards the centre or outward are rubbed off, so that after a year or two the tree presents as nearly as possible the shape of a vase or goblet, with a hollow centre and an even exterior outline with a thin wall of foliage. In our cool climate of the Blackwood I have come across trees so trained bearing bunches of apples and pears all along the leaders forming the framework of the tree.

#### MODIFIED VASE FORM OR LOW STANDARD.

It is apparent from the outset that such a symmetrical and open system of training, if adopted under a climate such as ours, would result in much damage being done by the scorching sun to both the tree itself and to its crop of fruit. I have purposely referred to it here so as to spare to the beginner in fruit growing the trouble as well as the disappointment of taking his pattern in training his young trees from the classic sources favoured in Europe. The Californian modified vase, with a low standard, has now proved itself to be the best suited to Australian conditions,

and it is this system of training which I shall have in my mind in the course of the following notes

### FIRST PRUNING.

Young budded trees in nursery rows present, the first season of their growth, the appearance of a straight switch, with good buds all along the stem. Sometimes they grow so vigorously that they throw out laterals. Both such young trees are found in nurseries. As their customers like to see as much growth as possible, nursery-men generally send out their trees without cutting them back.

Experienced orchardists generally prefer, when ordering from the nursery, one-year-old trees, which are merely straight switches with good buds all along the stem. These they can cut back, as shown by the dotted line in the figure, to the height they prefer, with a length of stem pretty well uniformly the same all through the orchard. If they plant trees with a head ready formed in the nursery they cut it short back on the laterals. Those who, on the other hand, have little or no experience of fruit growing, would do wisely to select from the nursery trees with their heads ready formed. When cutting back, especially in the warmer and drier localities, a stem 15 to 18 inches high will be found the best. In the cooler districts it can be given a height of 18 to 24 inches. Cut back to a good bud, care having been taken that the tree has not been planted too deeply, but that its collar, or point of junction between the roots and the stem be as nearly as possible flush with the surface of the ground. If the tree has suffered much, and the buds are very small, the bark leathery and wrinkled, the stem somewhat dried, and the roots much injured, it is advisable to cut the stem lower still, say at a height of about 9 inches from the ground, or even lower, but in every case above the graft. In such cases, however, the proper height should be given to the stem, either by pinching the straight shoot which will grow from it as soon as it reaches that desired height, or by cutting it back later on at the time of winter pruning. From a stem topped to a height of 15 to 18 inches several short shoots will be sent up from the upper buds; of these, three or four of the best shoots, placed symmetrically round the stem, are allowed to grow, all superfluous vegetation being rubbed off. These

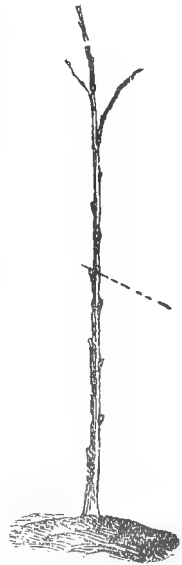

A Yearling Tree without Branches.  
The cross line shows where to cut back when planting.—Barry.

three or four shoots, which form the main limbs of the tree, should be placed in such a manner that they form a well-balanced head, and do not all come out in a bunch together, but spring out of the stem with an interval of an inch or two between them. This knits them better to the trunk, and they are less liable to split, as, they sometimes do in windy weather when grown in forks and laden with fruit. The apricot more especially, with buds very close together, has a tendency to grow its limbs all in a bunch.

Three limbs growing symmetrically round the stem are better than four. During the first season, these three or four shoots are left to grow without interference, so as to favour as good a root system as possible. Should one of the limbs grow with such exuberant vigour that it draws all the sap for its own use, to the detriment of the other two or three, it would be advisable to pinch off the tip and check it, so as to maintain a fairly equal growth of the head. A tree is very easily thrown off its balance at this stage of its growth, and unless properly trained and watched it might be difficult subsequently to re-establish the harmony of growth between the main branches that constitute the head.

#### SECOND PRUNING.

During the summer following the first pruning, the young tree should be allowed to grow unchecked, so as to ensure a good root development. Some young trees, however, at times persist in sending up one solitary shoot. Should this be the case, the tender growth is pinched back when it has reached a length of five or six inches, and this will excite the bud immediately underneath into life, with the result that the three or four limbs required to form a well-balanced head will be secured.

The reverse at other times happens, the young trees sending up a bunch of shoots, or such vigorous and luxuriant shoots that there is danger of the stems splitting. To guard against this it is in such case also, although for a different purpose, advisable to take in the sails, and relieve the plant of any excess of shoots, or of its threatening top weight.

During the first winter following the planting of a yearling tree, the three shoots, or may be the four which constitute its head, are shortened to four to ten inches, according as to whether these shoots are feeble, or strong and vigorous. Fruitgrowers often get their trees from the nursery at this stage of their growth, and the accompanying figure illustrates their shape after pruning. This operation excites the somewhat

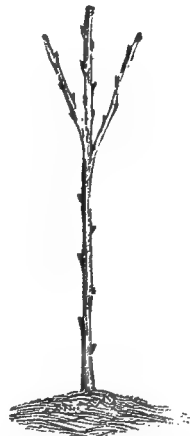

Pruning of a two year old tree from the bud.—Barry.

dormant buds at the base of the shoot into active life. As previously said, the terminal bud should be a plump and healthy one. It should be directed either upwards, downwards, or sideways, so as to prolong the growth of branch outwards or inwards, or towards a lateral blank space.

The growth of the main shoots is regulated by pinching, and should a third or fourth twig grow amongst them between the forks they are rubbed off. When the tree is ready for pruning a third time it has then, if three main limbs only, six branches, which, at the time of the

### THIRD PRUNING,

are cut back to 6 to 12 inches, according to their strength. Two of the top shoots on each of these branches with an upward direction are left, and the lateral shoots from the other buds on the limbs below are pinched back in the summer time, when they are a few inches long, to three or four leaves.

These little tufts of leaves shelter the branches, strengthen them by converting sap into woody tissues, and ultimately develop fruit spurs. Branches which approach the vertical line most are cut shorter than those inclined to an angle to thus force the buds at the base to grow.

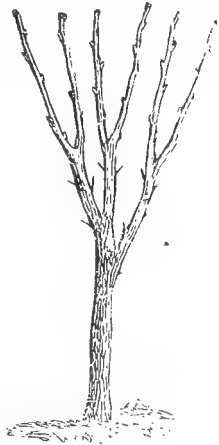

Winter pruning of a tree three years from the bud.—Barry.

### FOURTH PRUNING.

The same treatment described in the case of the first, second, and third pruning is applied in the case of the fourth pruning and generally at this age the tree will begin to bear readily. At this period a stocky, low standard tree will have been formed, which will have a well-balanced head of branches growing in an upward direction, and carrying fruit spurs all along their length. Such a tree will resist high winds well, can easily be approached by horse and implements, so that comparatively little hand labour will be required to keep the orchard in a high state of cultivation; the crop will be evenly carried along the main branches, which will not stand in need of artificial props, lest they should break down under the load of fruit which, at this early stage, they will begin to carry. The pinching of the superabundant laterals is best done in the early autumn, when buds, which would otherwise have remained sterile, are transformed into fruit buds. This operation saves much butchering in the winter time, as by suppressing either entirely or partly an undesirable shoot at an early stage, much sap, which

would be turned into wood growth, destined to be cut off in the winter, is saved, and the energy and the vitality of the plant thrown into more useful channels. This practice leads to the enunciation of the fact that severe winter pruning induces wood growth, while

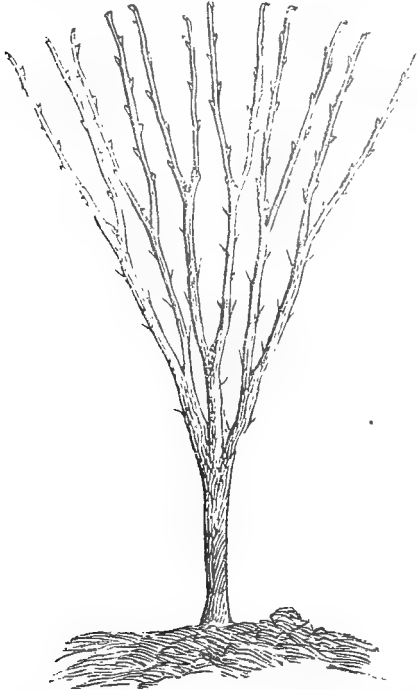

Young standard tree, four years from the bud, after pruning.—Barry.

summer pruning tends to fruit production. Thus, if a tree is stunted, and for some obscure reason does not make much wood, but shows a tendency to produce more fruit buds than it can safely carry, prune close in the winter; if, on the other hand, a tree grows so quickly that all its energy is wasted in wood and leaves, and does not pause to produce fruit, either summer pruning or root pruning will throw it into bearing. By such means the plant, realising, while in full flow of sap, that its constitution has been attacked and its life menaced, will make an effort to reproduce its kind forthwith, and the result will be the evolution of leaf buds into fruit-bearing spurs. Subsequent prunings consist

mostly in rubbing off water shoots, in suppressing branches that cross and rub against one another, and trimming the twigs and the fresh growth made during the season's growth. At this stage the tree will have ceased making much wood, and will begin the business of setting and carrying fruit crops.

#### REDUCTION OF SWELLINGS AND HIDE-BOUND TREES.

At the time of pruning swellings are occasionally noticed on the stems or limbs of trees. These swellings are either due to the disproportionate growth of the scion or fruiting part, compared with the stock or root end of the tree.

They may also be due to strings used in previous seasons as ties, which have cut through the bark. These swellings, which interfere with the free circulation of the sap, must be reduced. This is best done by running longitudinal incisions from C downwards to

the stock B. The bark will thus expand, and should the deformity continue the next season, these incisions should be renewed.

Trees which have been neglected, or whose growth has been stunted by the presence of moss and lichen, scale insects or other pests, or by want of drainage of the soil, by the aridity and poverty of the ground, or are debilitated in consequence of having been allowed to bear too early, often show a miserable, sickly appearance. Their growth is stopped, the bark becomes tough and leathery; they are hide-bound. The cause of the mischief may have already been rectified, and still they will make no growth.

Such trees should be similarly treated at the time of pruning. They should be cut hard back and at pruning time the knife being run longitudinally through the bark, from the heel to the top of the stem, and even along the main limbs. It is also advisable to whitewash the stems of such trees. Lime, in the shape of whitewash, is well known to be beneficial in most bark diseases.

Under this treatment the stunted trees of last season are seen to spring into fresh and healthier growth. The cambium or growing wood layers force the strip of leathery bark apart, the stems and limbs are soon seen to swell, the sap runs freely from the roots to the top branches of the plant, and the whole growth looks healthier.



Incision to reduce the swelling of the graft or the stem.

#### INCISION TO CONTROL THE GROWTH OF SHOOTS AND BUDS.

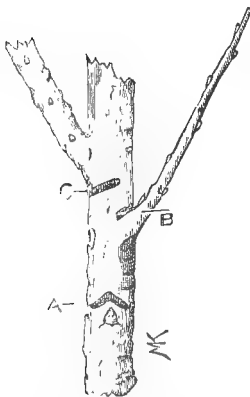

Incisions.—*Du Breuil.*

Should, during the preceding growing season, any one of the lateral branches have been imperfectly developed, it should be cut back lightly when pruning, and if it is much too small compared with the others it is sometimes advisable to make, immediately above the point of attachment to the branch (B), a notch or small incision through the outside layers of growing wood, so as to force the sap to run up the branch and develop it. The cut should be prevented from healing too rapidly. It is also sometimes desirable for the symmetry of the tree to force a dormant bud into growth, and in that case an incision as shown at A will be found useful. On

the other hand, should a strong branch become uncontrollable in spite of heading back, it may, in extreme cases, be advisable to check the flow of sap towards it by making an incision as shown at C, immediately below its point of attachment to the stem.

Thus we have a means of transforming a wood bud into a fruit bud and *vice versa*, by making a cut below the rudimentary bud if we want a fruit bud, or above it if we want a wood bud. These methods should, however, be only used with discrimination, else more harm than good would ensue.

#### RENOVATING OLD TREES.

Fruit trees planted in good soil and possessed of a good stem are susceptible of living to a great age. It, however, often happens that through years of neglect their branches have grown to excessive length and are, to a great extent, deprived of fruit shoots, or that the crop is carried up too high, hence adding considerably to the cost of gathering; or again the trees are diseased, and in order to successfully combat the pests which infest them they must be shortened in. Again, the variety of fruit the trees bear may be unsuitable, and it may be expedient to change it by means of budding or of grafting. In all these cases it may be desirable, or even imperative, to shorten the tree and head it back. For that purpose the saw is called into requisition, and the cuts are smoothly pared with a sharp knife, the wound being then smeared with clay, or with the shallac paint, or some of the other paint already referred to.



Top of an old plum tree headed back for the purpose of renovating.

The figure illustrates an old plum tree which has thus been renovated. The plum, better than most other fruit trees, stands cutting back hard to old wood without showing symptoms of dying back, which, under similar conditions, are often shown by apples and more particularly by peaches and nectarines.

Early in the spring the roots of the tree, which may be good for many years more, become active, the sap commences to move upwards, and a number of hidden and dormant buds are excited into life. Shoots burst out of the old stumps, and as they grow they should be thinned out to the number of three or four only, well placed and likely to form a symmetrical head. Should these few shoots, which are destined to serve as main limbs, grow too rankly, they may be pinched or cut back during the summer, and laterals will grow on the tree, which will be shortened at the time of winter pruning. If, however, these shoots show only a moderate growth, they are better left alone until the pruning season, when

they are cut back and treated as directed under the heading "First and second pruning."

Except in the case of plum trees referred to already, it is inadvisable to cut back trees in the process of renovation to blind stumps, but this is preferably done just above a young branch or a small shoot, so situated that it can be used for giving start to the fresh growth. Old apple trees, apricots, and especially peaches, are at times killed through overlooking this detail. The sap becomes stagnant, a dying back process sets in, which carries off the limb. Peach trees more particularly must be cut back with judiciousness when it is intended to renovate them, the reason being that fewer buds are found on the old bark of peaches and nectarines than on the old bark of pomes, and what few buds there may be left are less easily thrown into active life again than buds of apple and pear trees.

When renovating trees of the citrus tribe it is also advisable to cut large limbs above on young, fresh growth, although in their case this is not so essential as in the case of deciduous trees, and more especially the peach. These trees are fairly well stocked with miniature dormant buds, which are thrown into life whenever the emergency arises.

#### SPLIT LIMBS.

The method of training trees explained above presents one disadvantage. The suppression of the central stem and the starting of several main limbs from the same level on the stem often exposes

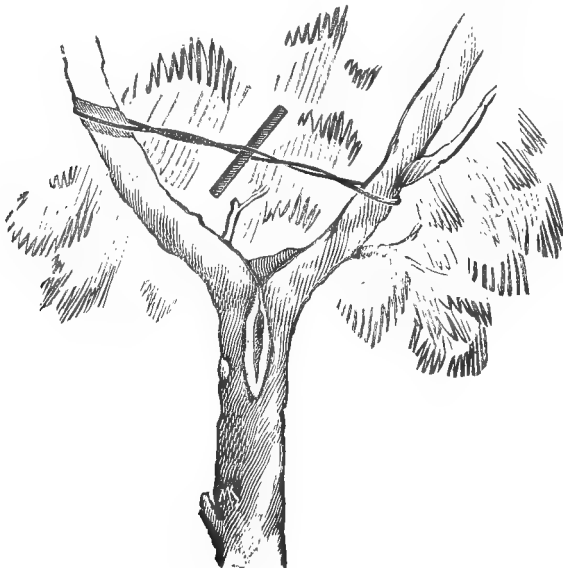

Method of supporting split limbs.



those limbs loaded with a heavy crop of fruit, and swayed by high winds, to split from the trunk. It is, therefore, advisable at the time of shaping the young tree to see that the branches do not all spring from the same level, but that an interval of a couple of inches or even more be left between them to insure their better attachment to the trunk. Limbs which threaten to split can also be strengthened by using the pruning saw and the knife, and so distribute the weight over the branches that the weak ones are relieved of too heavy a strain.

In particularly dangerous cases it becomes necessary to bind the bifurcated branches together so as to prevent them splitting. The accompanying illustrations show both the right and the wrong way of doing this. Ropes are temporary ties at the most; besides, they stretch easily, and finally rot and snap. A piece of fencing wire, doubled round the limbs and twisted until the requisite strain is obtained, is often used in orchards, but this method presents the serious inconvenience of cutting through the bark and interfering with the circulation, the growing wood overlapping from above and

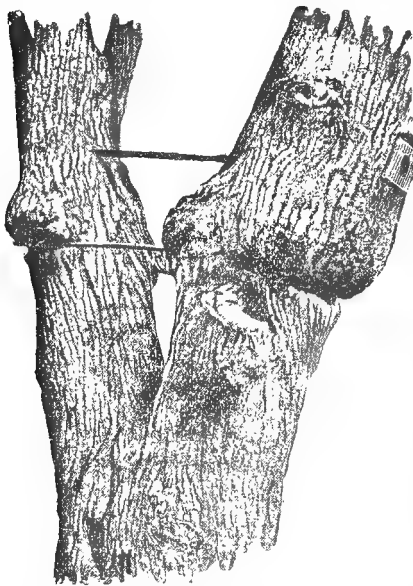

The right and the wrong way of supporting weak limbs. (*Garden and Field*).

presenting an unsightly swelling. Whenever a contrivance of this sort is used, pieces of lath or some bagging or leather pad should be placed between the limb and the wire to shield the bark. When the forked limbs are actually split, the torn and jagged wound should be smoothly pared with the knife and the two pieces brought together.

Above the iron band in the illustration a more suitable contrivance is shown for mending split limbs. It consists of a straight iron bolt, run through auger holes bored in the limbs; the bolt is supplied with a large head and a large nut with a washer, and is screwed up to the proper point. The hole should not be much larger than the bolt, so as to exclude the wet or the air; for that purpose it is advisable to apply a little tar or wax where it enters

and leaves the bark. Such a bolt will not damage the limb or interfere with its expansion.

#### FRUITFULNESS OF SPURS AND WOOD.

Easy circulation of sap results in formation of new leaves and formation of woody tissue and fruit spurs. Pruning by cutting off hardened, gnarled, moss-infested twigs and branches forces the sap into fresh channels, and new fruiting wood is produced. The desiccation of fruiting wood and its barrenness varies with climate and soils. Where conditions are favourable, the climate mild and moist, the soil fertile and congenial, spurs and wood will prove fruitful for twenty to thirty years, as is instanced by the pear. In a dry and parched climate, on the other hand, or on unsuitable soil, the useful life of such wood might not exceed five or six years. Apples, plums and many other trees are subject to the same influences. Peaches and nectarines require frequent renewing.

#### THE INTERMITTENT BEARING OF FRUIT TREES

can often be avoided by proper manuring. A heavy crop is often followed by a light one, the strain on the tree being so great that its reserves are more or less depleted and insufficient to feed a full crop for the coming season. That exhaustion of the tree, if not the result of some plainly explainable cause, can often be prevented by appropriate manuring, when the tree generally bears much more regularly. As will be seen further on, the fruit buds are formed a season or two before they blossom and set, and if that period of formation coincides with the time that the strength of the tree is overtaxed by heavy bearing, it follows that the blossoms will set badly and the cropping will suffer. This can be counteracted by providing an adequate quantity of readily assimilable fertilisers, bearing always in mind that an excess of nitrogenous manure favours wood growth instead of flower buds and that phosphates assist in developing the fruiting qualities.

Well-grown fruit trees generally begin to bear in four years—stone fruit earlier—when they should not be allowed to overbear or else they become stunted and unproductive.

#### ROOT PRUNING.

Some trees, and more especially apricots, exhibit at times an exuberant wood growth, and fruit but sparingly, or not at all, all the energy of the plant being diverted towards the branches. Root pruning often induces those trees to bear. This is done in the autumn, when the tree has finished its active growth for the season and when the sap runs sluggishly, the shock being at that time less severe, while during the following few weeks the energy of the tree will be partly spent towards the transformation of fruit buds from the leaf buds, which, unless checked, would next spring

have continued to run riot. The method, sometimes recommended, of indiscriminately cutting with a spade all the roots of such a tree in a semi-circle one year and completing the circle next season, and two or three feet deep from the stem, is to be deprecated. The better way is to dig a trench a couple of feet wide and eighteen inches deep four or five feet from the stem, then with a small fork hoe work gradually towards the stem, laying some of the main roots bare. When about two feet from the stem the long straight roots only, and all roots pointing downwards, are cut off with a sharp knife or a saw, the cut being afterwards smoothly pared; the other main roots with some fibrous roots on them are cut three feet or so from the stem and then as many of the other small rootlets as can be spared are left untouched, covered evenly with soil sifted through the fingers, the holes being subsequently filled in with ordinary soil; the ground is then watered to settle the soil round the roots, and it is advisable to mulch lightly. This operation is done on one side of the tree the first year, and is repeated on the opposite side the subsequent autumn.

Now that information applicable to the pruning and training of all trees in general has been given, a few remarks respecting the individual peculiarities of the most important fruit trees and shrubs in cultivation will be found of use.

#### PRUNING THE APPLE AND THE PEAR.

The pruning of these two kinds of trees, which both belong to the genus *pyrus*, is very much alike, and will for that reason be considered under the same heading.

In shaping and training the trees the first four or five years of their growth, the detailed information which has been given with regard to the management of low-standard trees should be generally followed.

Like other deciduous trees, they can be pruned whenever the wood is mature enough, which is indicated by looking at the terminal buds and the yellow colour of the leaves. Pruning should then be pushed forward rapidly, and the prunings removed before the ground gets sodden with rain water. Deciduous trees, unlike citrus trees, should not be touched in the active growing season, except with the thumb nail, cherries and apricots, as seen below, forming the exception to this general rule.

Some varieties of apple, such as the Irish peach, the Jonathan, and also some pears, bear the best fruit at the extremities of their long, slender, and decumbent shoots. For that reason their leaders which yearly extend the growth of the main branches must every year be shortened lest they should carry at their extremity bunches of fruit which would bend these branches and destroy the symmetrical growth of the tree. In the case of these trees the small side shoots, which measure a few inches in length, are not pinched

back, as explained further on, but allowed to bear as they like best, *i.e.*, at their extremity; the weight of the fruit bending them, cause some of the buds at the top of the bend to swell and mature, when the shoot may safely be cut back and shortened.

The Bartlett pear has much the same habit of bearing. The Winter Nelis, on the other hand, typifies those kinds which only bear on the small wood spurs on the main branches, and the twigs or darts as a rule are not fruitful.

The method described is pursued until the main growths of the tree become very short or almost cease to move at all, when a certain number of these fruit spurs are cut off, so as to induce new growth. The rapid formation of numerous fruit spurs will stunt a tree; when this is the case they should be cut out at pruning time, otherwise the trees will be short lived. On the other hand, with such varieties as Ben Davis and Baldwin apples, which have a more compact form and a better distribution of fruit, thinning the branches should be practised after the bearing stage is reached. A wise rule to follow consists in cutting out or back every year to get a healthy growth of wood.

According to the habit of growth of the tree it is pruned to an inner bud, if it is intended to close it in, as in the case of the Yellow Bell Flower, which would otherwise soon reach the ground, like a weeping willow; to an outer one, if it grows too straight up after the manner of the Northern Spy or the Bartlett pear, which grow like poplars. If it is intended to train a branch in the straight line, it is pruned to an outer bud one year and to an inner bud the next year.

The branches of irregular-growing sorts, or of those exposed to the influence of high winds, will require to be secured for some time by stakes and soft-tying material.

If we examine a young shoot of an apple or a pear tree of the previous season's growth in the winter when the tree is in a dormant stage, we find leaf buds all along its length. When the sap begins running, in the spring, the terminal buds produce wood shoots, the others on the middle of the twig called "darts" are either transformed into fruit buds straight away, or produce short side shoots, which in subsequent years carry fruit buds. The buds at the base remain dormant unless excited into life by the suppression of those above them, so that by shortening a branch the sap, which naturally has a tendency to rush to the points, feeds these small

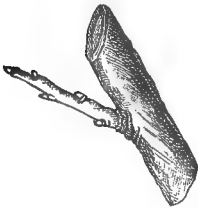

Small shoot in the middle of branch called "dart."

dormant buds at the base, starts them into growth, and forces them into what will eventually become fruit spurs. By following the mode of training and cutting back described above, we have, therefore, around limbs and branches, well distributed about the head, leaf buds which will continue the growth of the tree, and also fruit spurs and fruit buds evenly distributed all over the tree.



Young fruit spur near the lower end of branch or basal bud.

After the fifth year of training, and the sixth year in the case of some later varieties, and when the tree has settled down to the bearing stage, little hard pruning will be required. The new wood of the leaders is trimmed back every year, and all dead wood, branches that cross and rub against another, and water shoots, are cut out.

The fruit spurs, however, require at that period some management, and will then continue bearing for many years more; unless these spurs are looked after we have trees over-bearing one season and taking a rest for one season or two after. This is accounted for by the fact that if in young trees the fruit buds are several years in process of formation, they take in bearing trees two or three years, according to circumstances, and it becomes necessary, in order to renew and maintain their vigour, to systematically cut off the old part periodically and thus favour the formation of new buds at their base.

#### MANAGEMENT OF THE FRUIT BUDS AND BRANCHES.

In pinching back side shoots intended to carry fruit buds, care must be taken not to shorten them too severely, but allow them about four inches. If pinched too short, the little butt or shoot either ceases to grow and dies, leaving a vacant space on the branch, or else a year or two after this excessive pinching, two small basal buds push forth on each side of the suppressed shoot; those will ultimately blossom, but at the loss of a season or two, or, again, premature shoots will grow, which will likewise be a longer time



Shoot rightly pinched.

setting to fruit, and are not likely to be so fruitful as better constituted shoots properly pinched would be.

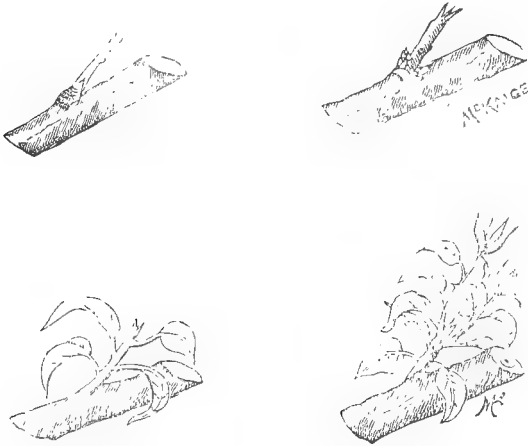

Shoots pinched too far back, and the result in different stages of growth.

We have seen already that the basal buds which grow slightly the second year of



Terminal shoot partially fractured.

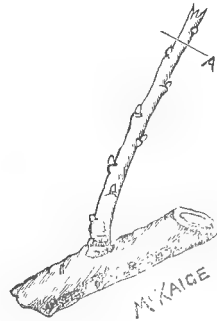

Terminal shoot cut back 9 to 12 inches.

pruning eventually form young fruit spurs. The shoots or darts showing in the middle of the twig grow a little more; neither are interfered with. The shoots, on the other hand, towards the end of the branch grow more vigorously, and are cut back at the time of pruning, or are partially

fractured. They will, after a few years, also carry basal fruit buds and darts.

The third year after pinching back the young terminal shoot, the basal buds (see page 147) have only developed a rosette of flowers, having a bud in the centre, and have increased a little in length. They now have the appearance shown in the figure illustrating a matured fruit spur, the bud being plumper. They blossom the following spring, and are now matured fruit spurs (as seen below):—



Matured fruit spur.

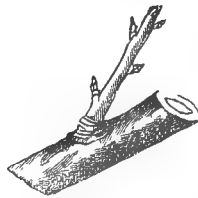

Two-year-old darts.



Fruit spur after first fructification

At that period the darts have also developed several fruit buds, and probably also the shoots at the top end of the branch.

At the fourth season of pruning, the fruit spur has fructified, and has formed at its termination a spongy swelling called a *purse*, while it carries at its base smaller buds, which become flower buds in the course of two years or so.

Should one of these buds grow into a vigorous shoot A, it is pinched back at C; the swollen purse, being liable to decomposition, should be cut off at the top, as shown in the figure. The buds on the dart are now a little more advanced, and will soon burst out into blossom, which at the subsequent winter pruning, after fruiting, is treated like the basal buds carrying the purse, as shown above, and so are the buds on the terminal shoots.

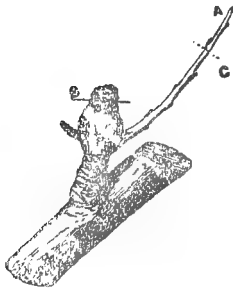

Fruit spur with small branch pinched.

As illustrated and mentioned above, the fruit spurs, after bearing, often after a year or two produce new flower buds at their base, these spurs having ramified as shown in the figure; so also the fruit spurs on the darts, which, after eight years or so, will be some-

what as represented in the accompanying figure, and after a few more years will represent the appearance shown in the woodcut.



Six years' ramified fruit spur.



Eight years' fruit spurs on a dart.

It is now advisable, in order to have fine fruit, to cut some of these buds back, so as to insure to the fruit a sufficient supply of sap, and this is done as shown above. The sap then forces into growth some fresh dormant buds at the base of the enlargement. If the fruit buds have already grown to large dimensions, they are gradually cut back, the first year to B, and the following at C, and the next at D. Should they be cut straight away at D, there will in all probability not be much fruit the next year, whilst the tree will be forced into fresh wood growth.



Method of pruning an old fruit spur.—DU BREUIL.

---

NOTE.—Most of the illustrations given in the chapters on pruning the apples, pears, and apricots are from Du Breuil's "Culture of Fruit Trees."—A.D.



## PRUNING THE QUINCE.

No fruit tree is more neglected than the quince, which is hardly ever pruned. Its natural habit of growth is that of a confused and scattered bush; by proper training, however, it can be made more shapely and more productive. A stout and straight trunk should be secured by cutting off all the other stems and keeping it tied up to a stake to prevent it from straggling. This is cut back the second year to a height of 12 inches from the ground, and treated in the manner described when dealing with the training and shaping of young trees.

The bearing branches of the quince are small twigs produced on wood at least two years old; these produce besides short shoots, on the point of which the fruit is borne singly. At pruning these bearing branches are shortened back and produce new fruit spurs.

## PRUNING STONE FRUITS.

What has been said about the early training of deciduous trees as low standard, applies to stone as well as to pome fruit. The subsequent management of the fruit spurs of stone fruits differs, however, in several points from that of pome fruits. In the former, the fruit spurs require two to three years for their growth, but when formed they last, with proper attention, for a long period. In stone fruit the fruit spurs are of much quicker formation, and in the peach and nectarine, notably, they blossom the spring following their first appearance on the previous season's growth.

## PRUNING THE PEACH AND THE NECTARINE.

The peach and the nectarine, like the apricot and the plum, are profuse bearers, often inclined to over-bear, and are in consequence not very long-lived, especially the first two, whose period of useful existence extends to 12 to 15 years, unless their strength and exuberant vitality are checked and controlled by judicious pruning and thinning out of the superabundant fruit crop.

Liberal manuring is essential to all heavy fruiting plants, and in this respect peaches and nectarines are exacting in order to keep up their productiveness. This matter is referred to further when dealing with the Intermittent Bearing of Fruit trees and with the Dropping of Fruit.

At the time of planting, if a yearling tree, cut them back to a straight stem about 18 inches high, and prune to side branches, on which are left one single bud at the base.

From their habit of growth, the peach and nectarine require constant and yearly prunings, the method adopted in these instances being that of *shortening in*.

A standard stone-fruit tree is trained in precisely the same manner as described above, with a low head, which affords shade

to the roots and the trunk and limbs and facilitates pruning, spraying, gathering, etc.

A clear understanding of the constitution of the bearing shoots of these trees will throw light on the best method of pruning them.

On account of the larger size of the circulating channels in these trees, the sap tends to rush towards the extremities of the shoots much quicker than in other trees, and the buds that do not push and form shoots the first season are—unless the branch which carries them is cut back—lost, as, unlike most other fruit trees, they are not excited into growth by cutting back in subsequent seasons. This explains how it is that trees that have been neglected or wrongly pruned in their youth present long limbs denuded of young wood and bark, and look like skeleton trees, which soon perish after over-bearing themselves.

In the peach, nectarine, and apricot the fruit branches are productions of the season's growth, the fruit buds forming one season and blossoming the next. In the first two, more especially, the fruit is borne on wood of the previous season's growth, and any limb or part of a limb destitute of such wood is sterile, so that the great object of the grower is to so prune the tree by cutting hard back a proportion of the lateral twigs that it is always covered with a regular and constant succession of annual bearing shoots.

In the case of the peach and the nectarine wood that has borne fruit will bear no more. It should be cut out.

The young shoot (one or two feet long) of the peach and the nectarine is furnished with a certain amount of wood buds and of fruit buds. There are one or more wood buds at the terminal points, fruit buds in the middle, and two or three wood buds at the base. If the branches are left untouched the fruit buds blossom and produce fruit, and the terminal shoots, which should carry the next season's crop, grow thin and weakly, as the fruit below have absorbed most of the sap and dried up the twig, while the wood buds at the base fail to grow, leaving a length of barren, useless stick.

By proper pruning, however, or shortening in, one-half or so of last year's growth, outside as well as in the centre, the lower parts of some twigs are cut back to one or two basal buds and the other twigs only slightly trimmed, the shorter ones being left untouched; still there may be too much bearing wood for the tree to carry and bring to full size and perfection, unless thinned out; the flow of sap is fully utilised by what is left of the young wood; the leaf buds at the base produce vigorous young shoots, which will keep the tree well supplied with bearing wood for the next season; the foliage will be more luxuriant, the fruit larger and more luscious. At the same time that the shoots are shortened in, those that have already borne fruit are cut out. Whenever practicable, leave for fruit the twig from the top bud of a two-eye spur, and shorten in for wood to two eyes the twig from the lower eye of that spur.

This method of pruning being carried out year after year, the small wounds heal readily. Large limbs have not to be cut back so often, thereby endangering the life of the plant, owing to the part drying up or decaying, and the sap poisoning the other parts of the tree and favouring the gumming, one of the worst diseases of stone-fruit trees.

After seven or eight years the growth of the main branches will slacken, and the pruning will consist mainly of the cutting out the twigs that bore fruit the previous year; (2) thinning out the twigs that will bear the following year; (3) cutting back half to two eyes and trimming the longer twigs of the remainder. The latter will depend on the location of the fruit buds. In shy-bearing varieties, where the fruit buds are towards the extremity of the twigs, the cutting back is omitted. In the case of heavy bearers like Early Crawford, Foster, Elberta, that have plenty of fruit buds all along the twigs, there will still be plenty left after cutting back. Do likewise with the nectarine and the almond.

Very vigorous trees are sometimes shy bearers, and can be induced to bear by continued summer pruning, and occasionally an autumn root pruning. In a good season, when fruit sets well, thinning out when about the size of a marble, and before the kernel has hardened, will prevent breakages owing to overloading, and also ease the tree and enable the remainder of the fruit to develop to larger size.

#### PRUNING THE ALMOND.

Almond trees require very little pruning after they are once shaped. The first few years the young tree is trained on the principles laid down when dealing with the formation of a low-standard or "vase"-shaped trees. Some varieties have a weeping-willow habit of growth, and all branches pointing downwards should be cut to insure the symmetry of the tree. After the third or fourth year the pruning will simply consist in cutting dead wood, cross and broken branches, and the shoots pointing downwards, which might interfere with horse cultivation. When three or more shoots grow from the fork of a limb, the number should, by pruning, be reduced to only two.

The almond carries its fruit on laterals growing on new as well as on old branches, and, unlike those of the peach, the laterals of the almond do not die back annually, but remain productive for several seasons; they should not, therefore, be cut back as in the case of the twigs of the peach that have just borne fruit.

#### PRUNING THE PLUMS AND PRUNES.

Low training is to be recommended for the plums and prunes, and cutting back severely, during the first three years, the long shoots so as to shape the tree, form a stocky and erect growth, and

favour the formation of fruit spurs along the main branches, where the bulk of the crop should be carried, thus preventing the excessive bending down of the branches under the weight of the fruit. The centre branches are well thinned out, thus leaving the interior more open to the genial influence of the sun, light, and air, and stimulating a consequent development of fruit buds in the inside of the tree, instead of leaving exterior branches to bear all the burden.

Should the tree show an inclination to run to wood and be tardy in putting forth fruit spurs, summer pinching, by checking its growth, will hasten the time of productiveness. When in full

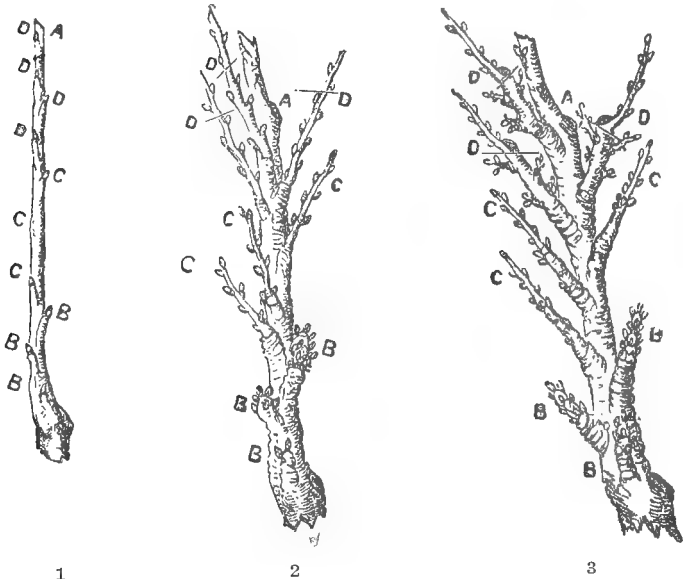

1. First year's pruning for forming fruit bud spurs. 2. Second year's pruning of fruit spurs. 3. Third year's pruning of fruit branches.

bearing the trees require very little pruning, beyond the removal of rank shoots which are misplaced and by the excision of dead wood and others.

The plums produce their fruit on small lateral spurs situated at the ends and along the sides of the bearing shoots, one year up to four or five years old, but mostly on two-year-old wood. These spurs will continue in bearing for several years.

For the guidance of growers and pruners, it may be stated as a general rule that the longer the wood of any variety of fruit trees takes to come into bearing the longer these spurs will remain fruitful.

A young plum shoot presents nothing but wood buds. That branch cut at A develops at the subsequent growth more or less

vigorous shoots, according as they are nearer to the extremity. Thus the buds at B will develop but slightly, those at C, growing about the middle, will grow two or three inches in length, while those shoots at D will probably reach a couple of feet. These last, with the exception of the terminal shoot, are cut back at the time of pruning to a length of four to six inches. The terminal shoot will thus extend and fruit buds will develop over the shoots left.

A year or so after, the short spurs at B give birth to a few flower buds, they have in the centre a wood bud which will slightly extend their length. These spurs must not be cut. The larger ones at C have flower buds in the middle and wood buds at the top and must be cut back slightly, while those at D, which are more vigorous, are shortened either by cutting or by partial fracture (see fig. ).

After another year and in subsequent seasons, the lengthened spurs must be cut back a little, so as to diminish the number of the blossoms and prevent the too great lengthening of the shoots. The same is done year after year, and when the fruiting shoots cease to bear they are cut back slightly, in order to develop new replacing branches towards the base.

Some growers only shorten plums and prunes once in every two or three years, after coming into bearing. This practice holds as well with pears, but will not do with peaches, apricots, and Japanese plums, which require similar pruning to peaches.

#### PRUNING THE APRICOT.

The fruiting habit of the apricot is much like that of the plum, and the same method of shortening-in is adopted in this instance.

It moreover, like the plum, bears fruit spurs on older woods; these bear for several years, and being provided with leaf buds at the base, can be renewed by cutting back when they grow feeble.

The apricot is a spreading and rank grower, which, unless kept well within bounds, runs long branches, which are liable to split asunder in windy weather, when laden with fruit. For that reason no two shoots should come from one bud, or be directly opposite.

Pruning to inner buds is greatly to be recommended when shaping the tree, while summer pruning is frequently resorted to just after the crop has been gathered, so as to promote the formation of fruit buds at the base of the twigs, and minimise the risk of gumming, the wounds healing at that time rapidly. When large limbs have to be suppressed, they should be well trimmed and coated



Apricot branch before pruning.

over with white lead, gum-shellac varnish, clay or other covering, otherwise there is danger of the branch dying back and killing or injuring the tree.

Unruly branches are better tied up with short string till they naturally grow in the position they are meant to occupy. During the first two or three years the trees need to be gone over two or three times during spring and early autumn to remove suckers the lateral growths that may start on the lower side of the limbs; these, if left, would check the growth of the permanent limbs above and the formation of fruit spurs. Many successful growers prune their full-grown apricot trees, if found to be shy bearers, soon after the fruit is picked, in the early autumn—preferably after a shower of rain (March in Western Australia)—though not too



1. Apricot fruit branch pruning neglected. 2. Fruit spur, year after first pruning. 3. Other fruit spur, year after first pruning.—DU BREULL.

heavily, unless the tree is weakened by over-bearing. This develops the buds for the next year. This operation is only recommended after the trees have reached the bearing age. While the tree is

still young and being shaped, all the pruning should be done in the winter. If the season is dry a good watering should be given to the trees after the summer pruning.

The management of the fruit branches is much the same as in the case of the cherry; unless the shoot is cut back, the basal bud will remain dormant, as shown in the following illustration of an unpruned branch, and the terminal shoot will grow, lengthening the branch which, long and lanky, will ultimately bend, and, unless propped up, break down under the load of fruit. It is, therefore, advisable to cut the young shoot at A (fig. 1). The sap will thus be forced towards the base, and produce new fruit branches (A, fig. 2). The primitive branch B is cut at *a*, and the new fruit branch A at *b*, in order to obtain the same result. In the last figure the small branch is cut at A so as to force a new fruit branch from the base.

#### PRUNING THE CHERRY.

The instructions given about the shaping of young trees apply to the cherry. The stem should be low and headed back to 12 to 15 inches when planting; the main limbs are also cut short, as the tree is very subject to sunburn. To guard against this it is a good practice to pinch all side shoots not necessary for the extension of the tree to a pair of leaves or two; fruit spurs will thus, in time, be formed all along the lower branches, while these tufts of leaves will afford to the branches protection against the sun.

Cherry trees in general produce their fruit upon small spurs, or studs, from half-an-inch to two inches in length, which proceed from two, three, or four year old wood. New spurs will continue to shoot out right up to the extremities of the branches; in the centre of every cluster of fruit spurs there is a wood spur, which, as it extends each season, bursts into blossom and carries the year's crop; this should be remembered when pruning. These spurs will carry fruit for several years.

Once the cherry tree has commenced to fruit it should, unlike the peach and the apricot, be very sparingly touched with the knife, as it is besides very subject to "gumming." This peculiarity of the plant is aggravated in individuals presenting long stems exposed to the sun, on trees with many forked limbs, and on those which have had large limbs taken off. It is found that by doing all the necessary severe cutting during the summer, and after the crop has been gathered, the wounds heal more readily. Whenever a branch thicker than the size of the finger is cut off it is advisable to apply to the fresh cut a covering of white lead, gum shellac varnish, of hot wax or of clay.

When big limbs have to be removed it is safer to do so in the summer, when it is less likely to gum.

The *Heart* and *Bigarreau* sorts, which are sweet varieties, are luxuriant growers, attaining large size, and possess large drooping leaves. Mazzard stock are preferred for these, the trees being long-lived, larger, and healthy when planted on fairly good loam.

The *Duke* and *Morellos* classes are slow growing sorts of the sour kind. The first have stiff and erect branches with smaller leaves, thicker and of a darker green colour than the preceding classes; the second or Kentish Cherries are of a bushy habit, with smaller leaves still and more drooping and more numerous twigs. The branches must be kept far enough apart to admit the sun and air freely amongst them, and the stem and main branches strengthened by cutting hard for several seasons. If the tree grows too luxuriantly, an occasional root pruning will throw it into fruit. They do best on Mahaleb stock, which gives smaller trees, but is more accommodating as regards soil. This stock gums on wet, retentive soil. If it were not for the sprouting habit, sour varieties on their own roots do very well. Cherry trees when shaped for the first few years as a rule keep a good form, and bear well without pruning.

#### PRUNING THE FILBERT.

Suckers should be carefully eradicated every season, and the bushes pruned somewhat after the fashion of the quince, or else they will be a mass of branches, and remain almost barren. Yet the filbert, in the majority of cases, is completely left to itself, although to be fruitful it requires proper and regular pruning. The blossoms, like those of the walnut, are monœcious, *i.e.*, the male flower or catkins, and the female flower are born on the same tree, but from different buds. These fruit buds bear in a cluster at the extremity of small twigs, and are produced on shoots of one year's growth, and bear the next.

Unless the bushes are pruned, they bear very heavily one year, and remain barren several seasons to recuperate. The mode of pruning consists in cutting back severely the first few years, so as to favour the growth of side shoots, which are shortened to prevent the whole nourishment being carried to the top of the branch, the consequence being that small shoots grow from their base, which carry fruit. By this method of spurring, bearing shoots are produced, which would otherwise have remained dormant.

#### PRUNING THE WALNUT AND THE CHESTNUT.

Much of what is said about the pruning of the fig applies to these trees. Their habit of growth is shapely, and the growers will, by cutting off misplaced branches, broken or dead, and by shortening bending limbs, do much to keep them growing symmetrically. As their feeding roots are close to the surface, light hoeing



only should be done in close proximity to the trees. They should be trained with a general upright tendency, so as to interfere as little as possible with cultivation. Limbs branching low down will protect the stem from sunburn.

#### PRUNING THE LOQUAT.

The loquat, or Japanese medlar, has hitherto been raised from the seed as a tree suitable for wind breaks. The choicer varieties are, however, now propagated by grafting or by budding, either on its own roots or on the quince, to which it is botanically somewhat related. In the first instance, it forms large trees, which take four or five years to start bearing. In the second instance it comes into bearing at an earlier age. When grown for shelter the higher trees worked on loquat seedlings should be selected and trained with a stem three or four feet high. In the second case, whether it is on its own or on quince roots, it should be headed lower down. As the tree carries permanent foliage, and later on heavy crops of fruit, the main limbs should be as strong and sturdy as possible, and trained with a generally upright direction. These in course of time, as the branches extend and carry more foliage and more fruit, will gradually be bent down, hence the importance of throwing strength and vigour into them at an early stage. This is done by encouraging the growth of three or four leaders, low down on the stem (if not grown as a wind break); all other shoots are either cut off or pinched back, and the young tree is subsequently shaped much in the same manner as has been explained in connection with the shaping and framing of young trees generally. The fruit bunches issue from the terminal point of young shoots. They bear at their base wood buds, which will in growing season push out young shoots. These, if too numerous, should be thinned out to two or three only, so as to insure for each its due share of light, air and sun. The decaying flower stalks are cut off, as well also as all dead branches.

#### PRUNING THE FIG.

Fig trees naturally form shapely heads. They are best shaped when young with the main arms arranged symmetrically round the stem. Figs for table purposes are headed low, so that the fruit can be picked without difficulty. Figs for drying are headed higher, so that the picking of the dead ripe and fallen fruit can be easily done over the smooth ground. The fig tree suckers pretty freely, and these should be removed in the winter time. Wherever the ground is rich the tree will often run excessively to wood, and in that case root pruning will force it into bearing. Drooping branches are cut off, and those growing obliquely upright retained. Dead wood and branches that cross and interfere with one another are suppressed, but the end of the shoots should be sparingly

touched with the pruning knife on account of the mode of bearing of the tree. This is as follows:—The fruits are carried either singly or in pairs in the axils of the leaves, and they appear on the branch as growth proceeds. If a tree is examined after it has cast its leaves it is seen that all along the younger branches scars show where leaves grew the previous summer. At intervals, just over these scars, diminutive buds, which will in the spring constitute the first crop of figs, appear; while a pointed conical wood bud crowns the head of these branches. When spring comes the first crop of figs shows more plainly; the fruit hangs down from the branch without a leaf alongside of it. Further on the conical terminal shoot grows on and leaves come out around it; just in the axils of these leaves more diminutive buds also show, which, later in the summer, constitute the second crop of figs. In prolonged seasons the growth of terminal shoots, as well as of laterals, continuing without interruption, may in this manner evolve even a third crop, but more generally the third crop remains dormant until the following early spring, and it is then a first crop again. It is thus seen that if laterals and terminals are cut back in the winter a proportion of the first crop is cut off, and this pruning leading to the growth of a greater number of laterals, these will produce a larger second crop proportionately with the number of young shoots which have burst into growth. No apparent flower is seen on the fig, those organs being hidden from view by the skin which covers them; as the fruit enlarges the blossoms expand, and when fertilised the seeds mature.

Old fig trees which have grown in a distorted manner and require rejuvenating are simply cut hard back to the height desired, and the numerous latent buds under the bark will, in the spring, start growing; these shoots should be thinned out to a few only. Large wounds should be dressed with some covering mixture.

#### PRUNING THE OLIVE.

The tree should be kept low by removing the centre leader, or else it will grow to a great height. Trained with a globular head, somewhat vase-shaped in the middle, permits of easier and more careful gathering of the fruit by hand, and a larger surface exposed to the sun and light.

During the first year or two the main effort should consist in throwing all the vigour and energy of the young tree into one stem only. This is shortened to a height of three feet or so, and a head formed by allowing three to four branches to grow. Every shoot or branch not needed permanently is removed early to avoid inflicting large wounds. Like all fruit trees, great expense is saved in gathering the crop by having the trees branched low; this also enables them to better resist high winds.



Smyrna fig.



Fig Branch showing First and Second Crops.







Two years old Passion Vine on trellis.



Three years old Passion Vines trellised.

(Errata, page 175 *Six feet* instead of *six inches*, second line from bottom.)

The olive bears its crop on the growth of the previous year, and it is therefore essential to favour the multiplication of new shoots in order to increase annual production. This is done by shortening the terminal shoots when shaping the trees, suppressing the "gluttons," or fruitless water shoots, removing all branches that are misplaced, crossed, or are in the way, and keeping down the suckers. A dense growth of foliage in the centre of the tree should be reduced by thinning out some of the branches. This also checks the black scale and the sooty mould. Whipping the branches in gathering the crop, or pruning off the young growth, will make the tree barren the following season.

The best time for pruning is after the severe winter frosts are over, and just before the sap begins to rise in the spring. In this country, however, where ground frost only is experienced, pruning can be done at any time in the winter, provided care is taken to coat any fresh wound with the gum shellac varnish, or a thin paste made of cow dung and clay.

#### PRUNING THE PERSIMMON.

Persimmons bear on new wood off the previous season's growth, hence the advisableness of pruning hard back to induce fresh growth. When cut the plant exudes through the wound a corrosive sap, which cakes on the blade of the knife or the secateur, and causes the cut branch to die back, unless the blade is, at frequent intervals, cleaned on a piece of leather.

#### PRUNING THE PASSION VINE.

The Passion Vine planted in the spring or the early autumn on a moist sandy loam, liberally manured, is an exceedingly profitable crop to grow. By means of proper pruning a winter crop, the only profitable one, can be secured, instead of the summer crop which would ripen when the market is well supplied with fruit. As these vines are not long lived, beginning to bear the second year, and being spent when five or six years old, it is found convenient to plant them midway between rows of figs or citrus trees, which when the passion vines are grubbed out, remain in sole occupation of the field.

Seedlings are easily raised by sowing in pots, tins or boxes, or plants may be obtained by striking cuttings. If the weather be cold at the time a hot bed and a glass or calico frame are helpful, as the plants are tender and do not stand frost. They are set out when six to nine inches high, at distances 12 to 15 feet apart, in rows of the same width. It is necessary to train them on a trellis with posts about nine inches wide, and six inches long, set 18 inches in the ground, with stronger strainers properly strutted at the end of the rows.

When the young vines grow the canes, a single one to each plant is trained up a light pole to the two wires which are stapled parallel and about six inches apart on top of the posts. The wire used is ordinary fencing wire. No laterals are allowed to grow along the stem, which is nipped when it reaches the wire when one leader is trained along the wire to which it is loosely tied. If two leaders are preferred they are trained T fashion. The shoots fasten themselves to the wire by means of tendrils and are allowed full sway. By the second season the trellis presents the appearance of a curtain of leaves and shoots which carry the crop. To encourage the winter crop the pruning is done in October or early in November by cutting these fronds a foot or so under the wire and the vines are heavily manured to force strong growth which will carry a main winter crop which will be harvested between Easter and the spring time.

#### PRUNING THE RASPBERRY AND BLACKBERRY.

At the time of planting choose root canes or suckers with a good root system attached; cut the cane back about 12 inches above the ground. From the base, strong and sturdy fruit canes will spring up. During the summer keep weeds down by frequent shallow hoeing, and at the same time knock off the superabundant suckers that may appear, leaving only from four to six. Deep digging with the spade or hoe is injurious to the plant, cutting its tufts of fibrous roots, which are surface feeders and nourish the crops. The plant carries deep, strong, woody roots as well, which produce and support the canes.

When the canes are several feet long they are topped off, and the subsequent laterals are pinched back about 12 inches from the stem. In the autumn, after the crop has been gathered, the old canes, which will not fruit any more, are cut off close to the ground



by means of a bent sharp hook fixed at the end of a long cane. This implement may be made of an old rasp; the cutting edges come together at a point like the letter V, and will cut on both edges, while it will also catch and hold the cut wood, which has to be removed from amongst the canes left on the plant. Thus the newer canes have a better chance, under the additional amount of sun and air they get, to mature and become more fruitful. These should have 10 to 12 inches of their ends cut off, as this part has not summered properly and is of no value. By this means also noxious insects and fungoid diseases are also better destroyed, and the cutting of the spent canes is easier than if they were dead and dry.



Raspberries and blackberries are either trained upright or without supports, by cutting hard back, or, better still, by trellising over stakes, laths, or wires. On large plantations the pruning is done more economically—more especially in the case of the blackberry—and consists, besides removing the worn-out canes in the autumn, in slashing the laterals on each side of the hedge in the summer, to allow cultivation, and tying the bunches together or to the trellis.

#### PRUNING GOOSEBERRY AND CURRANTS.

These deciduous shrubs do best in the cooler South-West corner of this State. They are struck from cuttings planted in rows 6ft. x 4ft.

Both receive pretty well the same treatment. At planting, short jointed young shoots are cut about 14 to 18 inches long. It is advisable to blind with the knife or the blade of the secateur all the buds which will be underground, or else the plants will be continually throwing up suckers. The accompanying illustration shows a bush with four branches, and a sucker springing from the base, which, unless carefully suppressed, will spoil its shape. The branches should be well raised above the ground, say, 12 inches. By this means the fruit is kept clean, and sun and air having full access to the branches, favour its fruitfulness. To ensure this, the branches are cut half back, with the result that there are at least double the



Gooseberry cutting.  
(J. WRIGHT.)

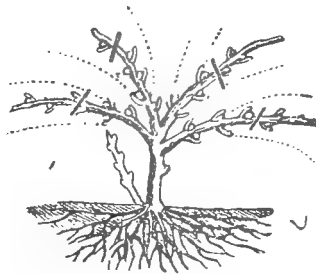

Gooseberry bush a year from the cutting.  
(J. WRIGHT.)

number the next season, as shown by the dotted lines. When the time for the second pruning comes these canes are cut back to about 16 to 10 inches in length to good buds pointing upwards or outwards, so as to keep the bush well above the ground. All young growths from the centre of the bush should be taken out.

Unless gooseberries are pruned, the fruit never or seldom attains to any size, and the bush is soon exhausted. The gooseberry, like the currant, bears well on spurs of two years or older wood; they also bear well on the young annual shoots, when these are left with a certain amount of discretion.

The illustration, one and two-years old wood on a gooseberry branch, shows on the older wood natural spurs forming all along it, and also two lateral shoots cut back at (x x). Unless these had been cut back it would have been almost impossible to pass the hand down the head of the bush for gathering the crop. It is essential that all laterals should be shortened to at least allow the hand to reach to the centre of the bush. A young shoot as shown in the figure may be left at intervals, so as to enable the cutting back every few years of the worn-out older spur-carrying shoots in the centre, as the bushes have a tendency to soon cease bearing, except on the outside.

The currant bushes are formed in the same way as the gooseberry, but when the plant has as many branches as it can carry, the additional growth of

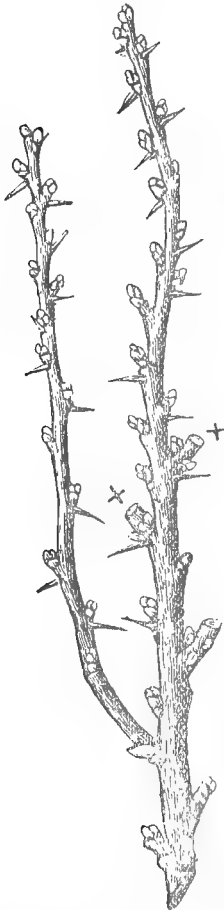

Gooseberry branch, one and two years old.—J. WRIGHT.

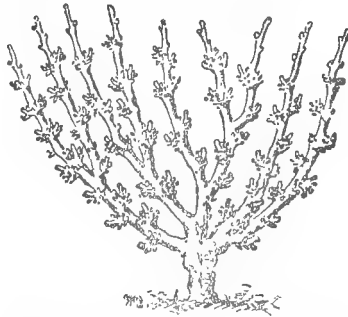

A red currant bush after pruning.—J. WRIGHT.

fresh new wood should not be encouraged. The distance between the branches should be such that the hat can be put amongst them. The illustration shows mostly fruit buds, except at the extremity of the branches, where the young wood has been cut back to about nine inches. In the summer both the gooseberry and the currant receive the following treatment:—

The young shoots which are seen pushing upwards are pinched back five or six inches in length, as shown at (x x) in the illustration; this



A fruiting branch of gooseberry.—  
J. WRIGHT.

will allow sun and air to reach the crop of fruit. A young shoot may here and there be left if there is room for its growth. Should fresh shoots show on those which have been cut back, they should be pinched again, so as to favour the formation of fruiting spurs.

the first season. The illustration shows the design of a convenient runner-cutter, which saves much trouble. The crescent blade is of such a diameter that it will encircle one side of a strawberry plant, and may be made with an arc of about nine inches. The appliance is pushed down on one side of the plant, and then on the other side, thus cutting all runners spreading around. Where the ground is moist the leaves of the strawberry plants are mowed clean off in the winter, then gathered up with a rake and burned. This checks the spread of the leaf spot

#### PRUNING THE STRAWBERRY

consists in trimming the roots at planting time, so as to favour the growth of the fibrous roots which will feed the plant, and later on in cutting all runners before the fruiting season, and as soon as they make their appearance. Unless this is done the fruiting of the plant will be seriously checked. Even after the fruiting, some growers still remove the runners, and only leave them on if young plants are required. In fact, treat all runners as weeds

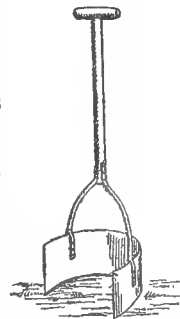

Strawberry runner-cutter.

disease. The same purpose is at times attained by spraying the beds with a solution of sulphate of iron.

#### PRUNING THE TOMATO.

If large-sized, early tomatoes are required, the plants should either be forced and planted out early, or sown towards the end of August, and protected from frost by means of a light mulching. Before planting out, clip all leaves off except the top bud; this will save their energy and cause them to grow quicker. One stalk only is allowed to grow, and lateral leaf shoots pinched off, the terminal shoot alone being allowed to remain. The fruit-bearing laterals are left on the plant, and soon set to fruit. The plant is trained either along short stakes or along a trellis, made of wire stretched between two short posts stuck at each end of the rows. This will keep the plants off the ground, and make the operations of spraying and picking easier. The tomato rot is not so severe on staked vines as on plants crawling over the damp ground, whilst by training the plants it is easier to get at the cut worms and the green caterpillars with arsenical baits and sprays. After a while a few leaf laterals are allowed to grow, if it is feared that the crop might be injured by sun-burn. Large-sized and early tomatoes will thus be obtained. For home use the tomato plant is seldom pruned. It bears enormously, but the fruit is smaller and somewhat later in ripening.

Successful tomato growers in the vicinity of Perth cannot compete in the early market with tomatoes grown around Northampton and farther north on the Gascoyne. In the cooler districts the expense of sheltering very early tomatoes against frost is so great that growers find the mid-season and late kinds more profitable, yielding as they do heavy crops and offering a large turnover.

Dwarf Champion is a favourite kind. It is compact in habit, the plant growing stiff and upright with very thick and short-jointed stems, and can be planted as close as 3 x 3. It crops well and does, owing to the small amount of space required between the plants, yield more to the acre. It has a firm, sound skin, is fleshy and of good flavour. Unlike most other varieties, it has a minimum of vines.

#### SUMMER PRUNING AND THINNING OF FRUIT.

As generally understood, pruning is an operation performed in the winter time, the object of which is the shaping of the plant, the adjustment of its wood and of its fruit-bearing capacity, and the easier management of such operations as cultivation, spraying, and dressing of the trees and vines, and gathering the fruit. In the summer months, however, the attention given to the plants for the purposes already named are supplemented by operations which are spoken of as "summer pruning." In its proper sense, summer pruning consists of pinching and disbudding.

## PINCHING

is the operation by which strong and vigorous shoots, which are out-running slower growing ones, are set back in order to give those other shoots a chance of catching up to the stronger ones, or of diverting the flow of sap into other channels where it is wanted.

It consists in suppressing, by nipping between the finger and thumb, the tender growth of terminal shoots, without, for that purpose, removing much or any of the foliage at all. It is by pinching that trees, when in their nursery beds, are given the shape which it is meant they should assume before they are sent out to customers to be planted.

Pinching is often practised in the summer for promoting the formation of fruit buds.

In pinching back side shoots, intended to carry fruit buds, care must be taken not to shorten them too severely; it is not too much to allow them three or four inches. If pinched too short, the little butt or shoot either ceases to grow and dies, leaving a vacant space on the branch, or else, a year or two after this excessive pinching, two small basal buds push forth on each side of the suppressed shoot; these will ultimately blossom, but this will involve the loss of another season or two, or, again, premature shoots will grow, which will likewise be a longer time setting to fruit, and are not likely to be so fruitful as better constituted shoots properly pinched would be, as already referred to and illustrated under Pruning.

When pinching back, and especially where the tree is full of running sap and of vigour, the shoots, instead of being cut or nipped clean off, are half broken through, and the terminal end left hanging. In this way the tension of the sap is partly diverted to half nourish the broken part, and the pressure is not strong enough to stimulate the growth of side shoots on that half-broken spur. At winter pruning that spur will present the appearance shown on the figure, the hanging piece will be excised, and the spur below will be stocked with fruit-bearing buds. These, after they have perfected their internal organs—a process which, according to sorts of fruit trees, takes from one to three years to accomplish—will, in due course, blossom and carry fruit.

## DISBUDDING

consists in rubbing off with the thumb any misplaced buds or tender shoot.

Pinching and disbudding are the most rational methods of gradually directing the growth of trees and vines, thus avoiding, at the time of winter pruning, the severe cutting of much unnecessary wood, on which some of the plant's best energy may have been spent during the growing months.

Indeed, if literally carried out, there would be little winter pruning left to be done, except shortening the leading branches of

young trees. However, if pinching and disbudding can be made to answer a useful purpose, the beginner should guard against too rigidly carrying it out under every circumstance, as it often happens that a better root growth, and much useful shelter in the summer months against the ardent rays of the sun, are obtained by not too strictly following the rules of pinching and disbudding.

To illustrate the methods of nipping and of disbudding, no better example can be taken than that of the apricot. In the main, it applies to most kinds of fruit trees. The apricot often throws out two or three shoots from the same knot. In shaping them a good deal of disbudding has to be done, as it is essential that they should not grow in a bunch out of the main stem.

Supposing at planting time the young tree has been cut back to a stick 18 or 29 inches high, the first shoot should start 12 inches from the ground, and not more than three others at most should be left to divide the space between that height and the top of the stem. Around that stem these three or four branches should be so disposed as to evenly balance, all other intervening shoots being rubbed off as they appear.

The first year it will be necessary to go over the trees at intervals and rub off all unnecessary shoots, thus to preserve the balance of the tree. Only strong and vigorous shoots are pinched back, any general heading back tending to dwarf the trees.

The method of cutting back the first winter has been explained in the course of a previous chapter.

When the young tree starts its second year's growth, all the shoots that come out on the underside of the main limbs—which have in the winter been cut back to 6 to 12 inches—are rubbed off, with the exception of two growing upward and outward on each limb, so as to continue the growth of the tree and maintain its proper balance and shape. These are the leaders and in summer pruning fruit trees should never be shortened, but are allowed to continue their straight growth.

The following year again, when the new shoots are a few inches long, they are again thinned down to two leading ones on each branch, all lateral growths and water shoots which tend to throw the tree out of shape being rubbed off. In doing so care must be taken not to take off the fruit spurs. Thus a strong tree is built up, with sturdy limbs, directed in an upward and outward direction, and capable of carrying a heavy load of fruit, well distributed around those limbs. The third year a few apricots will ripen, and after they have been gathered the trees are gone over and topped.

This operation favours the formation of fruit spurs, and, moreover, prevents the dying back of the branches, which, more especially with stone fruit trees, is a common occurrence when pruned in the depth of a wet winter, at a time when the sap is dormant and its healing power is not so marked. This done, it only remains



Apple tree before and after summer pruning.





to rectify early in the spring any errors of pruning which may have been done when the foliage did not permit of a correct view of the tree; at that time about one-half of the season's growth is cut back, due regard being paid to shape and balance, and cross shoots; water sprouts and dead branches are also taken out.

#### SUMMER PRUNING VINES.

Grape vines should not be topped too early, unless they happen to be in exposed situations where they are liable to be broken by strong winds. A great many growers I have met will, on the other hand, leave this topping until late in the season, so, as they fancy, to keep down labour, and at one stroke slash back both shoots and laterals. This practice has of late given rise to much adverse comment, and by degrees it is satisfactory to notice growers are moderating the intensity of this summer slashing, and the vines in consequence are much benefited both in growth and in production.

Wherever the vines are trellised very little topping, if any at all, will be required, and the shoots, after being tied up to the top wire, should be allowed to droop down in festoons. When growing bush-fashion, just enough trimming should be done to enable the team and implements moving between the rows without knocking the shoots too much. This is generally done early in November. Suckers and shoots bearing no fruit and not needed for subsequent pruning should, however, be rubbed off while still tender. In any case, topping has a weakening effect, as it deprives the plant of its lungs, and it should be avoided as much as possible. Topping while the shoots are young is not so severe. "Defoliation," which in cold and damp countries was practised for promoting the colouring and the ripening of the grapes, and thus saving them from bursting and rotting, is now seldom practised. In such a genial climate as the Australian it has nothing whatever to recommend itself, and should be absolutely discarded; all the efforts of the grower, on the other hand, should tend to provide for the grapes as much shelter as possible against the direct and scorching rays of the sun in the height of summer.



Vine cane rightly topped.

#### THINNING THE FRUIT

is an operation which consists in rubbing off fruit which is imperfect, insect-infested, diseased, overcrowded in clusters, and all surplus fruit which can well be dispensed with, thereby improving

that which remains, and sparing the energy of the tree. It is almost as important as pruning, and it is becoming to be regarded as essential to the profitable production of first-quality fruit as is pruning, cultivating, and manuring. Thus, in its proper season, it should receive as much attention on the part of the grower. The best time for thinning fruit is after the late spring frosts and other early accidents are passed, but before they have become of sufficient size to be a tax upon the tree.

In connection with thinning, the following points are worth bearing in mind:—Fruit trees form their blossom buds a year or two before these buds actually bear fruit. It thus follows that if a tree is allowed to overbear, it is hardly expected that it will also nourish as it should do the ensuing season's crop of blossom buds, and these being feeble and wanting in vigour and strength will, it is more than likely, in the proper time fail to set and perfect their fruit. Occasional heavy crops, therefore, more especially on trees growing in land of only moderate fertility, thus accounts for the fact that many trees which are allowed to grow and bear at their own sweet will are seen to carry prodigious crops one season and to be shy bearers the season after.

Overbearing not only enfeebles the coming season's buds, but it also severely disturbs the constitution of most trees. More energy is spent by them in perfecting the embryo, which is the essential part of the plant's seed or kernel, than is required in elaborating the pulp, and as much, if not more, valuable mineral constituents are abstracted from the soil in order to produce the seed as it does to manufacture the flesh part of the crop. Thinning, therefore, by reducing the number of matured seeds, considerably lessens the drain on the vitality of the plant and of the soil. Thinning, some argue, is a costly operation, and necessitates in some cases the expenditure of 6d. to 2s. a tree in labour spent on that operation alone, and in some cases, when old and vigorous trees have to be carefully gone over, it may cost as much as 2s. to 3s. for so doing. It should be considered, on the other hand, that the fruit must be picked sooner or later, and that as far as actual cost goes, it does not matter whether this amount is spent before the seeds form or when the fruit is ripe and ready for market.

The extra cost of picking, therefore, need not be entertained, as it is practically the same, whether part of the crop is picked when thinning and part at the time the fruit ripens, or whether the whole crop is picked at the one time. But, apart from the consideration of more even crops in a succession of seasons, thinning also influences to a marked degree the season's crop. Although less in number, fruit from a thinned tree equals in weight, and certainly surpasses, as regards size and market value, fruit from a like tree left unthinned.

A few figures will demonstrate that the lesser number of fruit from a tree that has been thinned equals or even surpasses in volume the crops from an overloaded tree that has not been thinned.

Two peaches measure respectively  $1\frac{1}{2}$  inches and 3 inches in diameter; some might imagine that the second is twice the size of the first, in reality it is eight times as voluminous, or, in other words, it would take eight times the number of  $1\frac{1}{2}$ -inch fruit to fill a bushel case which would hold a given number of three-inch peaches, for the cube of 1.5 is 3.375, whereas the cube of 3 is 27, or eight times as much. In the same way, two apples measure 2 inches and 4 inches in diameter, the larger fruit is not twice as big as the first, but eight times larger, for the cube of 2 is only 8, whereas the cube of 4 is 64, or eight times more. By a similar reasoning it is easy to demonstrate that fruit 3 inches in diameter is more than double the size of fruit 2 inches in diameter. For convenience of calculation in multiplying and dividing let us reduce the inches to quarter inches, and it is thus found that the volume of a fruit 12 quarters in diameter is more than three times the size in cubic measurement of another fruit 8 quarters in diameter.

Thinning not only increases size, but also improves appearance. It thus pleases the consumer, sells easier, and is more profitable to the grower. Poor fruit, on the other hand, gluts the market, brings down prices, and often does not pay for handling.

The theory of thinning having now been minutely gone into, a few practical hints regarding the method, so far as the different varieties of fruit trees go, may be of value.

Hand labour, as in many other operations which require skill as well as judgment, is the only practical method at present. Apricots are the first fruit which come ready for thinning, and this may be commenced when the fruit is about the size of marbles, and according to kinds in October or towards the beginning of November; at that time the fruit has stopped dropping, and the seeds have not commenced to harden. If too many are still left remove more just when the stone is hardening; as some of the fruit often drop off at that time, as explained below, a second thinning may not be found necessary.

Apricots intended for canning or drying should not go more than 10 to the lb., and to attain that weight they must measure  $1\frac{3}{4}$  inches in diameter, and should be thinned to about  $2\frac{1}{2}$  inches apart on the branches where the trees are well loaded, and have not been thinned by frosts or by beetles. Should they have dropped a great many fruit, and left them in bunches, the smaller fruit only, which would not develop, are rubbed off. Californian apricot growers consider that a healthy tree, having a body three inches in diameter, or a little over, should carry fifty pounds of fruit, and at 10 to the

pound this would take 500 full size apricots to the tree. By counting the apricots on a few trees, the operator soon learns when sufficient thinning is done, though the tendency at first is to leave too much fruit. Other practical growers estimate that, on a limb four feet long, with three to five laterals, there are, under conditions of unrestricted growth, between 100 to 125 apricots. When properly thinned and cut back that limb should produce not more than one-fourth of that number, or 20 to 24 apricots, but they are perfect in quality, superior in size, and classed as "extras." Apricots thus treated measure about  $2\frac{1}{2}$  inches in diameter; the ordinary fruit of this class measures only  $1\frac{1}{2}$  inches. In other words the larger fruit is over three and a half times the size of the smaller one, and the one-fourth thinned crop will occupy about three-fourths bulk space of the full unthinned crop.

Peaches and nectarines, next to apricots, require thinning, and according to the earliness or lateness of the variety, and of the locality, this operation should be done from the middle of November to the middle of December. They are generally thinned when about the size of a hazel nut, or a little larger, and a space of 4 to 6 inches should be left between each fruit. In Michigan and in Georgia, where peach growing ranks as one of the leading industries, only two peaches are left on twigs  $\frac{1}{8}$  inch in diameter, after the trees have been well pruned; three or four on twigs  $\frac{3}{4}$  inch in diameter, and if the land is not irrigated and is not naturally moist, only half; thus the trees will bear a good crop every year, and will be long-lived. All thinning is carefully done by hand, and all double fruit is taken off. The fruit on the points of the branches should be much further apart than that along the limbs of the tree. Peaches (except the early flat China peach), when less than  $1\frac{3}{4}$  inches in diameter, are not saleable, and by thinning their size are easily increased to  $2\frac{1}{2}$  inches, or three times the size; they then bring much better prices.

Apples are thinned from the time they are of the size of a hazel nut until they are thrice as large. The ordinary rule in thinning them is, after the tree is in good bearing, only leave one apple to the spur, or one, or at most two, where there were bunches of three to 10.

Prunes, it is the Californian experience, need thinning to give good fleshy fruit, especially when they show a tendency to overbear, when they only produce fruit that, when dried, is nothing but skin and seed.

Grapes in hothouses in the cooler climate of Europe are systematically thinned, and the careful grower, armed with a sharp pair of pointed scissors, snips off the tail end of the bunches, as well as the hanging wings or shoulders, and also all small and half-developed berries. By this means the bunch assumes the shape of a

somewhat conical cylinder, and every berry grows to a larger and more uniform size. In this country, however, where labour is so dear and grapes so cheap, and where, above every other reason, the mass of the consumers will give little more for grapes of extra quality than they would for ordinary fruit, it is questionable whether thinning grapes on a large scale and except for special purposes can be recommended as profitable. In my opinion, it would be better, under the conditions that obtain here, to regulate the crop by proper pruning in the winter time.

To conclude these notes on thinning fruit, it may be said that the grower who allows his trees to overbear, and the stock-owner alike who overstocks his run, both show an error of judgment; neither will attain the full measure of success which both might well reach but for following wrong methods.

#### THE DROPPING OF FRUIT.

There may be an "early" drop or a "late" drop. "Early" drop results generally from deficient fertilisation, as in the case of the Smyrna fig, where the male Capri fig and the fertilising wasp are absent. In other cases a flower may be pollinated and yet fertilisation not take place. Fertilisation causes fruit to set, but even slight, unfavourable influences may lead to the fruit losing its hold and so perish.

"Mid-season" drop is independent of fertilisation. Weather conditions have much to do with it; a cold snap, a thunderstorm, a prolonged drizzle at a low temperature, deficient light inside trees with thick heads.

The "early" drop, especially of the peach, is also often caused by the exhaustion of the food stored in the tree the previous year, especially before the leaves have had time to fully expand. Liberal manuring remedies this defect.

"Mid-season" drop in late summer is also often due to the extra demand for food the fruits make when the seeds are forming. A drought, a hot wind, will accentuate this. Lack of fertilisers and deficient nutrition, as want of phosphates, potash, lime, brings this about.

"Late" drop is often caused by fruits with short fruit stalks pressing one another out, especially when they grow in clusters.

#### MANURES AND MANURING.

The fruit-grower, having secured fruit trees and vines suitable for the purpose he has in view, will find few more profitable investments than the expenditure of a few shillings per acre in suitable

manures for the purpose of adding to the fertility of the soil or restoring the elements of plant food extracted from it by the crop.

The science of agricultural chemistry has thrown such light on the question of fertilisers and in the study of the requirements of cultivated plants that we are now able, with a certain amount of certainty, for every pound spent in suitable manures to expect a good return.

Few soils can do without manure of some sort in order to yield a maximum crop. Occasionally some are, if anything, too rich and too forcing for the purpose of fruit-growing; they induce an extravagant growth of leaves and wood to the detriment of the fruit. Wine grapes on such soils produce a thin must of little value for the purpose of wine-making as compared with must from similar grapes grown on poorer ground.

Most soils respond liberally to the application of suitable manures, and in order to satisfy the requirements of the crops entrusted to them, some knowledge of what is plant food and how plants feed must necessarily prove helpful.

#### WHAT IS PLANT FOOD.

Plants, in order to live and fructify, require certain elements of food, fourteen in number, some of which are supplied by the air, and some are found in the soil. Those supplied from the air are combinations and compounds of carbon, hydrogen, and oxygen; they constitute, with the compounds of nitrogen and sulphur, which are drawn from the soil, the organic part of the plant, which on combustion, either by fire, fermentation or putrefaction, return entirely or partly to the air. The mineral part of the plant which is represented by the ashes left behind after complete combustion constitute the inorganic constituents; they consist of potassium, phosphorus, calcium, magnesium, iron, silicon, sulphur, sodium, chlorine, and manganese.

Some knowledge of the composition of the tissues of plants and fruits will be useful for understanding in what proportion the different elements indispensable for plant growth occur in most crops.

Nearly two-thirds consist of *water* which disappears on desiccation, and the balance is made up mostly of combustible *organic matter* (carbo-hydrates), such as fibre, starch, sugar, gum, oils, alkaloids, and albuminoids, gluten, albumen, etc.; and also one to three per cent. of mineral or *inorganic matters* represented by the ashes.

To agricultural chemistry and such works as those of Wolff, in Europe, and Professor Hilgard, of the University of California, we

owe a great deal of the knowledge we at present possess, respecting the:—

MINERAL CONSTITUENTS OF THE ASHES OF VARIOUS PLANTS.

—	Potash.	Lime.	Magnesia.	Iron.	Phosphoric Acid.
Apple ... ..	35·68	4·08	8·75	1·40	13·59
Pear ... ..	54·69	7·98	5·22	1·04	15·20
Plum ... ..	59·21	10·04	5·46	3·30	15·10
Prune ... ..	63·83	4·66	5·47	2·72	14·08
Orange ... ..	48·94	22·71	5·34	0·97	12·37
Lemon ... ..	48·26	29·87	4·40	0·43	11·09
Grape ... ..	63·14	9·05	3·97	0·06	10·42
Peach ... ..	74·46	2·64	6·29	0·58	16·02
Apricot ... ..	59·36	3·17	3·68	1·68	13·09
Fig ... ..	48·60	9·12	5·32	0·84	11·20
Strawberry ... ..	49·24	13·47	8·12	1·74	18·50
Almond (shelled)	27·95	8·81	17·66	0·55	43·63
Cherry ... ..	51·85	7·47	5·46	1·98	15·97
Damson ... ..	45·98	12·65	8·17	1·19	13·83
Olive ... ..	60·07	15·72	4·38	1·19	8·35
Gooseberry ... ..	38·65	12·20	5·85	4·56	19·68
Quince ... ..	27·39	7·79	13·11	1·19	43·32
Chestnut ... ..	39·36	7·84	7·84	1·03	8·25

The above table taken from a paper on orchard manures by Mr. H. C. L. Anderson, M.A., formerly Director of Agriculture, N.S.W., gives an insight into the composition of the ashes of 18 of the most extensively cultivated fruits. Thus says Mr. Anderson:—Run down the column of figures under potash and see how widely the percentages differ—the ashes of peaches containing nearly 75 per cent. of that mineral (potash), and the ashes of apples not half as much. Then look at the figures under phosphoric acid, and see how they vary, from nearly 44 per cent. in the ashes of almonds and quinces down to less than one-fourth of that amount in grapes, and less than one-fifth in olives.

The other columns are not deserving of special attention, and are given merely to convince the student that the substances lime, magnesia, and iron are of lesser importance when compared with potash and phosphoric acid.

In practice four only of the fourteen mineral constituents of plants are, in the majority of cases, supplied to the crop under the form of fertilisers, and these are nitrogen, potash, phosphoric acid, and lime; the first three especially are the most sparsely distributed in soils and are also the most costly to replace.

With every crop of fruit removed from the orchard the available stores of potash, phosphoric acid, and nitrogen in the soil are correspondingly diminished.

## FERTILISING MATTER REMOVED BY VARIOUS FRUITS.

(From analyses by Mr. G. E. Colby, University of California.)

FRESH FRUIT. 1,000 pounds.	Total Ash.	Potash.	Lime.	Phosphoric Acid.	Nitrogen.
	lbs.	lbs.	lbs.	lbs.	lbs.
Almonds* ...	17.29	9.95	1.04	2.04	7.01
Apricots ...	5.08	3.01	.16	.66	1.94
Apples ...	2.64	1.40	.11	.33	1.05
Bananas ...	10.78	6.80	.10	.17	.97
Cherries ...	4.82	2.77	.20	.72	2.29
Chestnuts ...	9.52	3.67	1.20	1.58	6.40
Figs ...	7.81	4.69	.85	.86	2.38
Grapes ...	5.00	2.55	.25	.11	1.26
Lemons ...	5.26	2.54	1.55	.58	1.51
Olives ...	13.50	9.11	2.43	1.25	5.60
Oranges ...	4.32	2.11	.97	.53	1.83
Peaches ...	5.30	3.94†	.14†	.85†	1.20†
Pears ...	2.50	1.34	.19	.34	.90
Prunes, French ...	4.86	3.10	.22	.68	1.82
Plums ...	5.35	3.41†	.25†	.75†	1.81
Walnuts* ...	12.98	8.18	1.55	1.47	5.41

\* Including Shells.

† Estimated.

The above table shows that the drain of *Potash* on the soil from the removal of fruit crops is most marked in the case of olives, grapes, figs, peaches, prunes, apricots, lemons, and oranges, in succession, and least in almonds, apples, pears, plums, and cherries.

*Phosphoric Acid* is higher in the ashes of quinces, almonds, olives, figs, strawberries, grapes (seedless varieties have less), peaches, lemons, oranges (except seedless varieties), and less in apples, pears, and cherries.

Of *Nitrogen* olives require most, and are followed by peaches, figs, apricots, oranges, grapes, plums, lemons, while the fruits poorer in nitrogen are apples and pears.

*Lime* is extracted from the soil by lemons, oranges, olives, and figs to a greater extent than by other fruits.

These analyses throw some light on the great sustaining power of the olives and figs and nuts, which form an important part of the diet of the inhabitants of those southern parts of Europe and northern parts of Africa which encircle the Mediterranean.

They also show that the drain on the soil is greater in the case of the orange than in that of the apple, while the former is also more nourishing. It is seen that 100 lbs. of lemon or oranges contain over  $\frac{1}{4}$ lb. potash, .18 to .12lb. of nitrogen ( $2\frac{3}{4}$  to 2oz.), and .058lb. of phosphoric acid.



## PLANT FOOD REMOVED BY A GRAPE CROP.

Manuring must restore to the soil the annual removal of plant food.

In the case of the grape vine Müntz's investigations has brought out the fact that the warmer the climate the more complete the utilisation of plant food, so that for an even yield the vineyards of cold, northern climate (Champagne) require heavier applications of fertilisers than those of the warmer South (Midi).

The following table shows the removals of each plant food element by 100 gallons of wine in each of the districts below:—

PLANT FOOD IN LB. REMOVED BY 100 GALLONS OF WINE.

—	Nitrogen.	Phosphoric Acid.	Potash.
South of France ... ..	5·5	1·3	5·0
Claret (Bordeaux) ... ..	9·0	2·5	10·5
Burgundy ... ..	10·2	2·9	10·2
Champagnes... ..	10·9	4·1	18·1

In estimating the removal of plant food, the leaves and canes must also be taken into consideration, and an amount of fertilisers in excess of that indicated above allowed, especially of phosphoric acid, which is more difficult to absorb.

The Connecticut Agricultural Station showed in the same analytical manner that the fruit of a crop of stone fruit planted 18ft. x 18ft., or 130 per acre, on an average removes—

Nitrogen ... ..	20lbs.
Potash ... ..	22lbs.
Phosphoric Acid ... ..	5lbs.

The restoration of this will, strictly speaking, restore the ground to its fertility, but an excess must be provided as the rootlets do not travel far and food must be placed within easy reach.

## WEIGHT OF ONE ACRE OF SOIL AND OF ITS CONSTITUENTS.

To the untrained mind the perusal of a statement of a soil analysis conveys no tangible idea of the amount of the constituents declared therein and contained in any definite depth of soil, on, for instance, one acre of land. An approximate idea of the weight of average agricultural land gives a relative idea as to its richness or deficiency in any of the manurial constituents. One acre contains 43,560 square feet of surface, and a depth of one foot of that area therefore contains 43,560 cubic feet of soil. The weight of one cubic foot of soil varies greatly from the heaviest—rocky and sandy soils—to the lightest—peaty and clayey soils. The average

ordinary agricultural soil weighs about 80lbs. per cubic foot, so that the total weight of one acre of dry soil, one foot deep, would be 3,484,800lbs., or, say, 3,500,000lbs. This being so, a rich soil containing one per cent. of potash or phosphoric acid would contain 35,000lbs. of such plant food on an acre one foot deep. Similarly should the analysis disclose .1 per cent. the amount on that area would be 3,500lbs. and a crop removing, say, 5lbs. or 50lbs. of potash or of phosphoric acid a year would thus take 700 or 70 years, as the case may be, to exhaust such a soil absolutely of either of the substances referred to.

Although theoretically that lapse of time would be necessary for the crops to entirely drain that soil of its potash or some of the phosphates, it is nevertheless found that beyond a limit the soil tenaciously holds up and refuses to part in favour of the crop with the whole of its elements. It then becomes imperative to either restore to the ground those elements of plant food which have been removed, or by fallowing and spelling provide fresh supplies from the deeper strata and from the upper layer itself by the process of weathering. It is fortunate that the future is thus protected against the rapacity of the present. An examination of one of our own soils, a free dark chocolate loam, on the bank of a brook, will serve as an example of the teachings which soil analysis conveys to the mind. The land in question is under black wattle, flooded gum, and blackboys, and looks very fertile. Its analysis is as follows:—

Moisture	...	...	...	...	...	8.0200
Organic Matter	...	...	...	...	...	13.9900
*Phosphoric Acid	...	...	...	...	...	0.0255
*Potash	...	...	...	...	...	0.0848
Oxide of Iron and Alumina	...	...	...	...	...	1.7165
Carbonate of Calcium	...	...	...	...	...	0.6400
Soluble Silica	...	...	...	...	...	0.3660
Insoluble Silica	...	...	...	...	...	73.9260
-----						
*Nitrogen	...	...	...	...	...	0.420
Equal to Ammonia	...	...	...	...	...	0.510
*Sodium Chloride	...	...	...	...	...	0.3714
Magnesia Chloride	...	...	...	...	...	0.1504

This analysis shows that the land in question is a free dark loam. It contains 74 per cent. of sand and is also rich in humus.

Approximately, one acre of that soil, one foot deep, contains:—

Of Potash	...	...	...	$350 \times 85 =$	2,975lbs.
Of Phosphoric Acid	...	...	...	$350 \times 25 =$	812lbs.
Of Nitrogen	...	...	...	$350 \times 42 =$	14,700lbs.
Of Salt (Sodium Chloride)	...	...	...	$350 \times 37 =$	12,950lbs.
Of Magnesium Chloride	...	...	...	$350 \times 15 =$	5,250lbs.

Supposing this land was cropped annually, and the crop removed from the ground 50lbs. each of potash, phosphoric acid,

and nitrogen, the ground would be completely exhausted of the first in 600 years, of the second in 16 years, and of the third in 3,000 years.

This assumption, however, would be entirely unsupported in practice. The high percentage of salt is an indication that the land in question is badly drained; in fact, it is often waterlogged, and the soluble salts, instead of being washed out of the ground, accumulate to an alarming extent. The roots, then, of the more tender crop plants instead of feeding on a layer of soil one foot deep, would rot and corrode and only penetrate to a few inches. The mass of plant food revealed by chemical analysis is in practice found to be beyond the reach of the crops, and, besides, whatever amount of that plant food lies within reach of the shallow roots of the crop is of such a crude and raw quality that it is not in a fit state to act as plant food.

#### “AVAILABLE” AND “TOTAL” PLANT FOOD.

Bernard Dyer stated as a result of the Rothamstead experiments conducted over a period of 50 years the following definite conclusions could be drawn:—

That soil containing as low as .01 per cent. of phosphoric acid “available” required phosphoric manuring, but when the proportion reached .03 per cent. the necessity no longer existed.

The corresponding limits for potash he placed at about .0057 per cent. and .01 per cent. respectively. Judged by this standard many of our Western Australian soils would seem to contain sufficient potash, but as the bulk of it is locked up and insoluble, and not “available” to the roots of plants, an additional dressing generally shows notable results.

A soil may, on analysis, be shown to contain a high “total” percentage of nitrogen, phosphates or potash, and yet even under favourable climatic conditions yield poor crops. It is important that it should contain an adequate amount of “available” fertiliser or mineral to be utilised by plants, as food, immediately or within a few years.

#### DIFFERENT SOURCES OF FERTILISERS.

According to their origin or the sort of food stuff they supply to plants, manures are spoken of as:

“Animal Manures.”—These are characterised by the large quantity of nitrogen they contain, and the ease with which they decompose and yield their fertilising matter in available form—*e.g.* guanos, desiccated blood, bones, and superphosphate.

“Vegetable Manures,” which undergo decomposition more slowly; some, as the leguminous plants, having a large percentage of nitrogen—*e.g.*, green manuring, farmyard manure, sea-weeds, and oil-cakes.

“Mineral Manures,” which are extracted from minerals, and yield ash constituents to plants—*e.g.*, sulphate of ammonia, of lime, of potash, nitrate of soda, of potash, lime, etc.

Then again, manures are spoken of as “general” manures when they contain all the necessary elements for plant growth, or “special manures” when they only supply one or several of these elements.

These elements, again, are said to be “dormant,” “latent,” or “active,” according as they are insoluble or soluble in the corroding liquid which exudes from the rootlets and are thus made “available” for plant food or are locked up in an inert form in the soils.

Fertilisers, however, for the practical purpose of the fruit-grower and farmer, should be better considered as nitrogenous, phosphatic, potassic, calcareous fertilisers, according as nitrogen, phosphoric acid, or potash, or lime is the predominating valuable constituent.

NITROGEN is the rarest and most costly element of plant food; it occurs in abundance in the air as free nitrogen, but is not available in that form to most crops, except those of the leguminous class, on whose roots are gall-like swellings known as root tubercles, which are formed under the influence of micro-organisms living in the soil. It has been found that the presence of these bacteria and root tubercles enables some plants to draw from the vast stores of nitrogen in the air a supply which will enrich the ground in that valuable element and enable it to grow more abundant crops.

The more common source of nitrogen on the farm or at the orchard is found in farmyard manure, which consists of—

FARM YARD MANURE.	{	Water	...	70	—Nitrogen, .4 to .65 per cent. = 9 to 15lbs. per ton. Phosphoric Acid, .2 to .5 per cent. = 4 to 10lbs. per ton. Potash, .3 to .6 per cent. = 5 to 13lbs. per ton.
		Organic Matter	27	3	
		Ash	...	...	
		100			
A good dressing per acre, 8 to 10 tons.					

If used by itself, it is a very expensive method of manuring, although cost varies according to localities and distance and facilities for haulage. It generally comes, when all charges are paid, to 12s. per ton weight and sometimes more. Its value depends on its organic matter. On light sandy soils it helps to retain moisture; on stiff clay it prevents baking and keeps the soil open and spongy. In the case of fruit or vegetables, stable manure alone will not give maximum crops unless large quantities are used, and the cost of such manuring is greater than would suffice to produce the same result if less stable manure were used, supplemented by concentrated fertilisers.

The other forms of organic nitrogen, *i.e.*, the nitrogen of animal and vegetable matters which is chemically united to carbon, hydrogen, and oxygen, are—

*Ammoniacal Guanos.*—Are the best of the concentrated complete manures, as they have nitrogen 8 to 12 per cent., phosphates 15 to 25 per cent., and a little potash. It is a very valuable manure for most crops, but is rather expensive. It more nearly resembles farmyard manure in its composition than other artificial manures, and its great use is to replace this manure when the latter is scarce. A good dressing, 2 to 3 cwts. to the acre.

*Dried Blood.*—The refuse of slaughter houses, being a very complex substance, is also a very valuable manure, and contains nearly as much dry matter as flesh—*e.g.*, about 23 per cent. When dried without other substances, it contains about 10 per cent. water and 8 to 10 per cent. ammonia, with a little phosphate and traces of potash. It is one of the best forms of manures in light lands, and is not readily washed away. Often mixed with gypsum, which decreases its value; useful for making composts. Fair dressing per acre, 3 cwt.

*Dried Nightsoil or Poudrette.*—Contains 2 to 4 per cent. nitrogen, 3 per cent. phosphate, and 1.5 per cent. potash; often mixed with gypsum and earth, which reduces its value. A bulky manure which would hardly pay to carry a long distance, when freight and carriage is a consideration.

Other forms of organic nitrogen are those of seeds, such as cotton seed cake and other oleaginous seeds after the extraction of the oil.

Leather and peat are also classed as nitrogenous manures, but they are comparatively slow in their effect on vegetation, and for that reason are less valuable.

Nitrogen occurs as minerals and notably ammonium salts and “nitrates” and “nitrites.”

*Sulphate of Ammonia.*—Supplies one of the cheapest forms of nitrogen in the market. When pure, contains 24 to 25 per cent. of ammonia, equivalent to 20 of nitrogen, and is one of the most concentrated forms of nitrogen available. It is obtained from coal gasworks and extracted from the gas liquor, and is purified of the ammonia thiocyanate (a plant poison) it contains before being put on the market. As it is not quite so soluble as nitrate of soda, it is not so liable to be washed out of the soil as are nitrates. A simple test for showing the absence of most, at any rate, of the impurities with which sulphate of ammonia is likely to be adulterated is to throw a pinch of the sulphate on a red hot iron plate; the sulphate of ammonia, if pure, will be quickly volatilised and dissipate entirely. Applied at the rate of  $\frac{1}{2}$  to  $1\frac{1}{2}$  cwt. per acre

in the spring, mixed with some dry, well-ground material such as sand, earth, or other fertilisers, so as to ensure its even distribution. It is suitable for using in mixtures with superphosphate.

*Nitrate of Soda.*—As imported from Chili, contains rather more than 15 per cent. of N. or 18 to 19 per cent. ammonia. Its price is high in Australia. More soluble than sulphate of ammonia, and for this reason especially useful in a dry season, owing to its being deliquescent. Applied at the rate of  $\frac{1}{2}$  to  $1\frac{1}{2}$  cwt. per acre in the spring, mixed with some dry, well-ground material, so as to ensure its even distribution. Experiments I have conducted in manuring vines with this fertiliser have given very good results.

*The Combined Use of Sulphate of Ammonia and Nitrate of Soda.*—It is well known that the continued use of sulphate of ammonia on soils deficient in carbonate of lime is calculated to give rise to acidity of the soil; at the same time it is also known that the continued use of nitrate of soda gives rise to an alkaline condition in the soil. The suggestion has therefore been made, that by using a mixture of sulphate of ammonia and nitrate of soda in proper proportions, a neutral condition of the soil may be maintained, so far as the use of these fertilisers is concerned.

The correct proportions to secure this result are, in round numbers, 100lbs. nitrate of soda to 78lbs. sulphate of ammonia; or 100lbs. sulphate of ammonia to 129lbs. nitrate of soda; or, approximately, 4 parts of nitrate of soda to 3 parts of sulphate of ammonia.

*Relation between Nitrogen and Ammonia.*—Soil or manure analysis often express the nitrogenous contents as nitrogen or as ammonia. And in order to better understand the difference between the amount of each, it is useful to remember that 17 parts of ammonia ( $\text{NH}_3$ ) contain 14 of nitrogen (N) and that 66 parts of pure sulphate of ammonia, or 85 parts of nitrate of soda, also contain 14 parts of nitrogen. Most nitrogenous manures, however, are very expensive, and whenever it can be arranged green manuring which will be referred to below, offer the cheapest way of adding to the store of humus and of nitrogen in the ground. Excess of organic nitrogenous manures, it should be borne in mind, are often productive of harm, and cause such diseases as “die back” of the trees. In white ant infested districts it must also be used with caution. “I have used sheep manure for orange trees,” writes a Narra Tarra fruit grower; “it acts very well, but proves a hotbed for white ants.”

PHOSPHORUS is, next to nitrogen, the most costly ingredient of fertilisers, in which it occurs in the form of phosphates of lime, iron, and aluminium, or, in case of superphosphates, partly as free phosphoric acid. In good soils it rarely exceeds .2 per cent.

The trade uses with regard to phosphoric acid several terms which to the layman are not very familiar, thus:—

“Soluble” phosphoric acid implies phosphoric acid or phosphates that are soluble in water or in a solution of ammonium citrate or in a 2 per cent. solution of citric acid which approximates the acidity of the sap of foraging rootlets. It diffuses into the ground and thus reaches the feeding rootlets of the crop instead of lying inert in the soil, as do the mechanically mixed insoluble phosphates, until the rootlets find them out and attack them.

“Insoluble” phosphoric acid requires a stronger solvent than ammonium citrate to make it available as plant food.

“Reverted, reduced, or precipitated” phosphoric acid is phosphoric acid which was once soluble in water but which, by combination with lime, iron, or aluminium in the soil, has become insoluble again. In that form it is, however, readily assimilated by crops.

The chief sources of phosphatic manures are:

*Bones* found in commerce broken up as “half-inch,” “quarter-inch,” and as “bonedust”; the finer the better, as they act more quickly. Commercial bones are either “raw” or “steamed” and degelatinised. Their respective composition is—

Raw Bones.		Steamed Bones.	
	10 per cent.		10 per cent.
Water ... ..	10	...	10
*Organic matter ...	33	...	†18
Phosphates ... ..	50	...	58
Carbonate of lime...	4	...	8.5
Sand ... ..	.3	...	1.
Alkaline salts ...	2.7	...	4.5
	<hr/> 100.0		<hr/> 100.0

\* Equal 3.5 to 4.5 ammonia. † Equal 1.4 ammonia.

Bone dust and half and quarter-inch have a similar composition to the raw product they are made from. The coarser the bones the heavier should the dressing be. Bonedust is applied at the rate of 3 to 5 cwt. to the acre.

It is often used mixed with superphosphate in equal proportions, and in the case of orchards or vineyards in full bearing applied in quantities of 5 to 10 lbs. per tree or 3 to 5 cwts. respectively. Where the soil is of a stiff nature and dries hard the proportion of 2 of bonedust to 1 of super is preferable; whereas on friable loam rich in humus and fairly moist the super may preponderate.

*Bone fertilisers* are offered by the trade but are not as effective as bonedust, being largely a mixture of bones with other materials such as gypsum, marl, or superphosphate with ground rock phosphate, and show a larger percentage of “insoluble” or acid soluble phosphoric acid.

*Ground Rock Phosphate*, the raw material from which superphosphate is made, contains a large quantity of phosphoric acid in combination with lime in the least readily available form. It is only useful in sour peaty soil, and being slow of action a much larger

dressing is required to yield the same result as a smaller quantity of the more soluble superphosphate or bonedust.

*Phosphatic Guanos*, such as Abrolhos and Sharks Bay guanos, contain 44 to 50 per cent. of phosphate and only one half per cent. of ammonia, the balance being mostly sand and moisture. They can be got in several ton lots at a very reasonable price, and answer well when mixed with a small proportion of a more soluble phosphate, such as concentrated superphosphate and sulphate of ammonia. A fair dressing would be 3 to 4 cwt. to the acre.

*The Cave Bât Guano* found on our coastal limestone hills is also a phosphatic manure, and contains 1 to 3.5 per cent. of ammonia and 12 to 15 per cent. phosphate of lime readily available.

*Thomas' Phosphate Powder*, or Basic Slag, is another source of phosphates. It is derived by means of the Thomas Gilchrist process in making steel from pig iron by smelting it in converters lined with lime; when the iron is melted the air is blown through, part of the iron and impurities are oxidised, and the phosphoric acid combines with the lime, forming phosphate of lime. This contains 14 to 17 per cent. of phosphoric acid, equal to 30 to 36 per cent. of phosphate of lime, and also 40 per cent. lime, and 18 per cent. iron oxides, and 6 per cent. sand. It is very cheap in England, where it used to sell at the factories for £1 a ton, and was retailed at 30s., but is now much dearer. It is so finely divided that it acts very readily.

The soils most suitable for Basic Slag are: lands of a peaty character, rich in organic matter. Its action on heavy stiff clay is very beneficial, as it helps to disintegrate the soil and make it more friable, at the same time liberating a proportion of the natural potash in which most clay soils abound. Also on all kinds of pasture land, and on poor hill pastures. On light soils the addition of potash is usually necessary. On soils subject to "finger and toe" and "puff-ball" it should be given the preference for roots. It must not be mixed with sulphate of ammonia, guano, or dried blood.

*Coprolites and Apatites* constitute mineral phosphates of great value, either ground into a fine powder or for making superphosphates; they occur in some geological formations under the form of concretions, and consist of the fossil excrements and remains of extinct animals. They vary in richness from 10 to 75 per cent. of phosphates.

*Superphosphate of Lime*.—Either of the raw materials referred to already are ground and treated with sulphuric acid, thereby made more soluble, and hence quicker, in its action. The actual composition of superphosphate varies with the material of which it is made, and ranges from 35 to 40 per cent. down to 20 per cent. phosphates rendered soluble. In this state, owing to its diffusibility, superphosphate is able to permeate through a greater quantity of soil, and penetrates further than other merely mechanically-divided phos-



phates, and thus more readily taken up and assimilated by crops. A good dressing consists of 2 to 4 cwt. per acre; or, in conjunction with farm-yard manure, 2 cwt.

Whenever using superphosphate, better results are obtained when the soil contains a sufficiency of lime, *i.e.*, enough carbonate of lime to cause effervescence when a mineral acid is poured on to it. On land poor in lime it is advisable to use a larger weight of "basic slag" if it can be procured at a reasonable price, or bone meal or a mixture of superphosphate and bone meal. Basic phosphate or superphosphate mixed with a small quantity of lime and thus "reverted" is also preferred on soil poor in lime.

*Fermented Bones* can readily be prepared on the farm by mixing with bone one-third their weight of earth or burying them in the manure heap, moistened with water, urine, or liquid manure, and covering the whole heap with earth. After a time, depending on the temperature, the bones enter into fermentation, and crumble to powder, when they are dug out and used. Fermented bones act more rapidly than raw bones, and can be compared in their action to bone superphosphate.

*The relation of phosphoric acid ( $P_2O_5$ ) to phosphate of lime ( $Ca_3P_2O_8$ )*, such as is expressed in soil or manure analysis, is as 142 is to 310, or a fraction less than half. Thus bonedust containing 50 per cent. of phosphate of lime contains somewhat less than half this amount of phosphoric acid, or, in exact figures, 22.58 per cent. To convert the one into the other multiply the phosphoric acid by 2.18 (in practice 2.2) and the percentage of phosphate of lime is obtained. Conversely, divide phosphate of lime by 2.2 and the equivalent percentage of phosphoric acid is shown.

#### POTASSIUM

is the constituent of a fertile soil or of fertilisers which ranks third in costliness. It does not occur as such, but as combinations, such as chloride (muriate), sulphate, carbonate, nitrate, silicate, etc.

*Potash* is also known as potassium oxide ( $K_2O$ ), and as such is reckoned when valuing fertilisers.

In manures it occurs as sulphate and as muriate (chloride of potassium), the sulphate form being a little more costly than the muriate.

The chief sources of potash are—

*Wood Ashes*, which constituted for a long time the chief source of supply of potash used for agricultural purposes. The incombustible part of "ash" of farm crops and timber contains from one-fourth to one-third its weight of potash. For this reason newly cleaned land, well timbered, on which the wood has been burnt off the ground, will have a supply of potash proportionate to that contained in the ashes. Western Australian firewood usually leaves ashes low in potash, except the Peppermint (*Agonis flexuosa*), which, says E. S. Simpson, contains nearly 6 per cent. of potash.

*Kainit* is, on account of its low price in Europe, in great favour as a cheap form of potassic fertiliser. Owing to its great bulk, however, the price in Australia is about double what it is in England. It is chiefly extracted from salt mines at Stassfurt, in Germany, and was originally deposited from sea water, and is associated with salt, gypsum, and other saline substances. The crude kainit found in commerce contains 12 to 13 per cent. of potash (equivalent to about 22 to 24 per cent. sulphate of potash), 27 to 30 per cent. of magnesia salts of little or no use as a manure, and 30 per cent. of common salt, which in the Eastern districts of this State, particularly where the land is in places more or less permeated with saline matters, could certainly be dispensed with. It is more valuable in light loam than in heavier soils, which it makes more sticky. A fair dressing per acre would be from 3 to 6 cwt., mixed with other fertilisers, and worked into the soil by means of the plough or the digging harrows.

*Sulphate of Potash*, which is the chief potash salt in kainit, is also sold in a more concentrated form than in that crude salt, and is found in commerce with a percentage of 52 per cent. of potash (which is equivalent to 97 per cent. pure sulphate of potash), or more than four times the amount per cent. found in kainit. One cwt. per acre forms a good dressing, in conjunction with other manures.

Its pre-war price in Western Australia was £15 per ton, or 6s. per unit.

Fruit and vine growers prefer this form of potash which appears to improve the size, quality, colour, and sugar contents.

*Chloride, or Muriate of Potash*, is the most soluble of the various salts of potash, and when purified contains as much as 60 per cent. of potash or 95 per cent. of muriate of potash. It is obtained as a by-product in the manufacture of chlorate of potash, in the purification of nitre, and other manufactures. It occurs also in the Alsatian mines of the basin of Mulhouse as "sylvanite" (mixture of chloride of potassium and sodium) at 14 to 20 per cent. of pure potash ( $K_2O$ ), and in a purer form up to 50 per cent. Its use, however, is harmful on certain crops, as in the case of sugar beets, in which it lessens the percentage of crystallisable sugar, while potatoes are rendered waxy, and the tobacco leaves are deteriorated in value; in the soil it is, besides, apt to give rise to the formation of common salt, while the sulphate gives rise to the formation of gypsum, which, in saline soils, is especially of value.

Being as a rule cheaper per unit than the sulphate, it should be used in preference in soils containing sufficient lime, for most farm crops.

In soils potash occurs in quantities ranging from .01 to 2 per cent., equivalent to 350 lbs. to 70,000 lbs. per acre taken to a depth of 1ft.; it is derived from the weathering of minerals containing

it as an ingredient, and chiefly from felspars, one of the constituents of granite. Of these, the richest, Mr. E. S. Simpson, of the Mines Department, reports having analysed were from a pegmatite outcrop at Ferndale, Balingup, which yielded 12.56 per cent. of potash and another at Mahogany Creek going 12.2. It may be said that a soil showing .03 per cent. of potash on analysis does not usually need a potash fertiliser. Crops not fed off on the ground remove amounts of potash which vary greatly. Beets may remove as much as 100 lbs. per acre, and cereals about 30 lbs. A table given above (page ) gives the relative likings of various fruit crops for potash. The percentage of that element of plant food in soils usually rises with their contents of clay, but cases occur in which even heavy land is deficient in *available* potash. Reclaimed swamps and sandy soils are almost invariably benefited by the application of potash fertilisers.

#### *Potash in Western Australia.*

Besides the two cases of potash felspar mentioned above, Mr. E. S. Simpson draws attention to investigations made while potash was unprocurable during the war as to likely sources of supply within the State.

Amongst others he mentions the "Glauconite" sand from Mole Cap Hill, Gingin. He gives four analyses which show that the chalky outcrop which supplies the phosphated lime sold by Mr. V. B. Gordon contains a fraction under 2 per cent. of potash, while the glauconite sand under the chalk contains nearly 3 per cent.

Another mineral called "Jarosite," found near Northampton, is reported to contain up to 5½ per cent. of potash.

The most promising form from which a low-grade potash is likely to be procured is in the "Alunite" deposits of Kanowna, which, after roasting and treatment, says Mr. T. Blatchford, of the Geological Department, yield a material which contains up to 7 per cent. of potash, and can also be utilised as a source of aluminium.

#### SOIL AMENDMENTS OR IMPROVERS.

Besides the fertilisers reviewed in the previous pages, soils often need the application of methods of fertilising which exercise on them both a mechanical and a chemical effect.

Amongst the most commonly used amendments are:

LIME, which is especially valuable for the renovation of worn-out soils and for breaking down stiff clay and making it more friable and pervious to water; it supplies plant food; it assists in the decomposition of organic matter, and for this reason a soil poor in *humus* should receive more sparing applications of lime than soils of a peaty nature, or rich in organic matter; it sweetens sour soils in neutralising the acids; it decomposes injurious substances in the soil

(ferrous oxide, a plant poison, into ferric oxide, a plant food); it promotes the process of nitrification by encouraging the presence of special micro-organisms; it increases the fertility of the soil by helping some of the chemical processes which result in the more ready absorption by the soil of phosphoric acid, potash, and ammonia. Clay soils which show a tendency to "puddle" and form clods when improperly tilled, are greatly improved by a dressing of lime. This substance possesses the property of flocculating or coagulating the clay particles, thus opening the pores of such soils and making them less retentive of water and more permeable to air.

*Quick* or caustic lime, which results from the burning of limestone or carbonate of lime, is, chemically speaking, carbon oxide ( $\text{CaO}$ ), of which it loses 44 per cent. when roasted. It acts more energetically than carbonate of lime, or mild lime, and should be preferred for peaty and sour soils. Oyster shells and marble give the purest lime; our coastal limestone is not so pure and contains 6 to 20 per cent. of sand.

This quick lime when moistened takes up 24 per cent. of water and oxygen and becomes "slaked lime" or "hydrated oxide of lime," which, when exposed to the air, absorbs carbonic acid and reverts to carbonate of lime ( $\text{CaCO}_3$ ).

Thus—

20cwt. pure limestone yields.

11½cwt. quick lime, or

14¾cwt. slaked lime;

or putting it another way:

20cwt. quick lime when slaked produces

26cwt. slaked lime.

During this process it increases considerably in volume, and falls to powder. A bushel of good stone lime weighs, when quick, 90lbs.: when slaked, it will measure nearly three bushels; each of which will weigh about 45lbs. A bushel of unslaked oyster shell lime weighs 60lbs. When slaked it will measure something over two bushels, each of which will weigh 40lbs.

The quantity of lime to use at one application depends on the amount of vegetable matter the soil contains. Thirty bushels of lime (12cwt.) is a safe application if the soil is quite thin and contains but little vegetable mould. Several small applications of lime are safer than one heavy one. The chief objection of using lime in the quick or the slacked form is that it floats in the air as a caustic, impalpable powder, which is trying to the eyes and nose and also to horse and harness. *Gas lime* is another fairly cheap source of agricultural lime. It rarely, however, contains more than 40 per cent. of lime, the rest being made up of moisture and compounds of sulphur or sulphites and sulphocyanates, which are injurious to vegetation, and should be allowed to be corrected by the action of the air before being ploughed in. During this operation the noxious

sulphites are converted into gypsum (sulphate of lime). *Limekiln ashes* are also desirable land amendments; they contain about one per cent. each potash and phosphoric acid, besides some lime.

For the destruction of sorrel, heavy liming is recommended, and applications amounting up to two tons to the acre may be used for that purpose.

CHALK is dug out and exposed to frost, and then spread, as it is constituted of minute microscopic shells, as well as fragments of shells of larger size; it contains a little phosphoric acid generally in combination with lime as phosphate of lime, to the extent of 0.10 to 1.25 per cent. (or 100lbs. of this burned lime contains  $2\frac{1}{3}$ lbs. of phosphate of lime).

MARLS consist of carbonate of lime, generally resulting from the fragments of shells which have accumulated at the bottom of fresh water lakes, which have generally been filled up by clay or sand, or by the growth of peat. They contain from 1 to 2 per cent. of phosphate of lime, and at times small amounts of potash.

Marling only pays where the material is close at hand and can be put on the land at a cost of a few shillings a ton. An application of two to three tons to the acre is by no means excessive.

GYPSUM, or hydrated calcium sulphate, has been much used as a manure, but as it occurs in superphosphate and is not charged for, is rarely applied to crops nowadays. It occurs in places crystallised, and is found very useful for leguminous plants, especially for red clover, lucerne, etc. Applied from three to six cwts. per acre. Supplies lime and sulphate to the crops and acts as a solvent, which sets potash free from its state of dormant combination in the soil. Appears to promote the process of nitrification. Is a valuable absorbent on the manure heap and in stables, cow sheds, and poultry yards, where it fixes the volatile ammonia into non-volatile sulphate of ammonia. Very useful in reclaiming alkaline salt patches containing carbonate of soda.

The relative value of burnt sulphate of lime or plaster of Paris and of unburnt sulphate of lime or gypsum lies in the fact that roasting drives out the proportion of water of crystallisation; thus making a given weight of plaster of Paris richer in sulphate of lime than an equivalent weight of gypsum.

ASHES.—Supply in small quantities magnesium, potassium, calcium, iron, phosphorus and sulphur—all mineral matters necessary to the growth of plants, and for that reason they constitute a very good fertiliser. Besides their value as plant food, they also have on it a mechanical effect similar to that of lime. They are especially useful on light and sandy lands, rendering them moister. The value of ashes vary with the kind of wood burned, and with the care that has been taken of them. Limekiln ashes can at times be obtained at a reasonable price. They contain

about 1 per cent. of potash and phosphoric acid and about 40 per cent. lime. Ashes from burnt vine cuttings are rich in potash, and on that account they should be spread back on the land. It is the practice now to burn them in an iron furnace set on a sledge or mounted on iron wheels and drawn by a horse along the rows of vines after pruning in the winter. In this way the ashes resulting from the burning are evenly spread amongst the vines.

GREEN MANURING affords one of the best and cheapest methods of adding humus or organic mould to poor sandy soils more especially. The term is applied to some quick-growing crop which is ploughed in green. Two classes of plants are used: those which are not exacting in their demand for plant food and constitute a cover in the winter which checks loss by washing or drainage, and those which gather plant food from the air as well as from the subsoil and leave it on the surface for the use of succeeding crops. To the first class belong rye, buckwheat, rape, Cape weed, Cape and beardless barley; to the second, the legumes—clovers, peas, vetches, lupins—a class of plants capable, by means of the bacteria living in their root nodules, to absorb and fix the free nitrogen of the soil atmosphere. By the process of green manuring, loose soils are made more retentive, and clay soils lighter. Cow peas, although very desirable as green manure, are not used in orchards where winter-growing plants are exclusively grown. They are better suited for tropical countries where summer rains occur. For winter sowing the most desirable plants are crimson clover (*Trifolium incarnatum*), an annual which germinates and develops quickly. Eight to ten pounds of seeds will sow an acre. The growth of the crop will be greatly stimulated by the application of some phosphate and potash fertilisers. When grown, it will act in three distinct ways: as a winter covering to the soil, as a summer mulch, as a plant food gatherer. Experiments at the Jersey Experiment Station, U.S., found that a growth of 13 inches produced 168lbs. of nitrogen, worth £5.

The Canadian field pea has also given very satisfactory results. Sow about 85 to 100lbs. per acre, or plough the crop in the early spring, using a chain on the plough and a disc coulter to cover and drag in all vines under the earth.

Several kinds of trefoil invade our vineyards and orchards after a few years of cultivation and do much good as nitrogen gatherers: they are natives of Southern Europe and are annuals, viz., Hop clover (*Trifolium procumbens*), distinguished by its large yellow hop-like flower; Woolly clover (*T. tomentosum*), Clustered clover (*T. glomeratum*), Slender or Minus clover (*T. minus*), Burr trefoil (*medicago denticulata*), Subterranean clover (*T. subterraneum*).

The best method of growing a winter cover crop is to sow the green manure in the autumn (April) ploughing in the mass of the



Green Manuring.—Winter growth of Field Peas along alternate rows of grape vines.



Orchard under furrow irrigation.





green crop while it is still succulent (September and early October). When scarifying the planted land in the spring a disc cultivator gives very good results for the reason that it chops up the crop without getting tangled up in the vines.

Green manuring may, under particular circumstances, be detrimental. In localities of short rainfall it may lead to the desiccation of the soil. It is calculated that one part of dry vegetable matter requires 300 to 500 times its own weight of moisture, so that every ton of green manuring crop in a dry locality would absorb 300 to 500 tons of water; and unless plentiful rain or abundance of artificial water can be relied upon, the process may in some cases be detrimental.

The results of commercial fertilisers are much more marked when applied on land well stocked with humus than when used on land depleted of vegetable mould.

#### VALUE OF FERTILISERS.

Under the Fertilisers and Feeding Stuffs Act it is imperative on the manure vendors to furnish with the invoice for any fertiliser sold a certificate showing the per cent. of nitrogen, phosphoric acid (soluble and insoluble), and potash contained in the manure. Mention of any other ingredient is of little or no value, and may be considered as so much padding, which is liable to confuse the purchaser. Failure to comply with this enactment may be meted out by a £20 fine. The more concentrated the fertiliser is, as regards any one or more of the three elements mentioned, the more valuable it is, so much less dead weight having to be handled and carried to the field.

The value of the three chief elements of a fertiliser—viz., nitrogen, phosphoric acid, and potash—is not uniformly the same, and is mostly influenced by sea and railway freight, and by its degree of solubility. The market quotation is expressed at so much a "unit." The unit value being the value of one per cent. of the particular ingredient in a ton of manure.

Nitrogen in sulphate of ammonia or in nitrate of soda or of potash is worth in Western Australia 16s. to 18s. per unit. In blood, bones, or offal (ground fine) it is worth 14s. in this State.\*

If we express by 10 the worth of nitrogen in nitrate of soda, of potash, or of sulphate of ammonia and of ammonia in live guano, the nitrogen in blood and bones or meat is only worth 7, while in wool waste, hair, horn, and leather it comes down to only 2 or 3, that is to say:—If an application of nitrogen under the form of nitrate of soda, or the substances grouped with it, would produce a surplus crop of 1,000lbs. of fruit, an equivalent amount

---

\*NOTE.—These are pre-war prices and fluctuate from time to time.

of nitrogen derived from blood, bones, or meat would produce an increase of 700lbs., and a similar dressing of nitrogen from wool waste, hair, ground horn, or leather would only produce an increase of 200 to 300lbs. of fruit. It is thus seen how important in selecting the materials from which nitrogen, phosphoric acid, and potash are to be derived to see that the material is readily available.

Phosphoric acid varies greatly in value, whether it is soluble or insoluble in water. As regards "Citrate soluble" phosphoric acid—*i.e.*, from a phosphate soluble in a weak acid solution, such as one of ammonium citrate—the value is intermediate between the above two, thus: Water soluble phosphoric acid is worth in Western Australia 7s. Phosphoric acid insoluble in water is worth with us 3s. a unit, whilst citrate soluble phosphoric acid is worth here 5s.

Potash in soluble salts is worth in Western Australia 6s. to 7s.; while potash in natural manures, such as dried nightsoil, is worth 5s. and 4s. respectively. These prices, of course, fluctuate a little according to the state of the market, the quantity of fertilisers bought, and as to whether the transaction is a cash one or one involving terms.

The state of subdivision in which some fertilisers occur is hardly ever given in the analysis, yet this is a most important factor of the manure's worth.

To arrive at the value of a fertiliser, and unless it is specified whether the nitrogen, the phosphoric acid, and the potash are derived from the better prized material, these ingredients are considered as being derived from the baser ones when calculating values.

Knowing these values, it is easy, when furnished with an invoice certificate, to determine the real value of the manure offered. Thus a mixed fertiliser contains—

Nitrogen (as Sulphate of Ammonia) ...	4	per cent.
Phosphoric Acid—Water Sol. ...	5	"
"    "    Citrate Sol. ...	2	"
"    "    Insoluble ...	3	"
Total Phosphoric Acid ...	10	"
Potash, Muriate ...	4	"

This statement is treated as follows:—

4 per cent. Nitrogen and Sulphate of Ammonia, at 16s. ...	£	s.	d.
5 per cent. Phosphoric Acid, soluble, at 7s.	3	4	0
2 " " Citrate, sol., at 5s. ...	1	15	0
3 " " Insol., at 3s. ...	0	10	0
4 " Potash, at 7s. ...	0	9	0
	1	8	0
	<hr/>		
	£7	6	0
	<hr/>		

Or again, bonedust contains:—

Nitrogen	...	...	...	...	3·16 per cent.
Phosphoric Acid	...	...	...	...	20·20 „

Mechanical Condition—

Fine bone	...	...	...	...	42 per cent.
Coarse bone	...	...	...	...	58 „

After working out the relative percentages of nitrogen and of phosphoric acid, as fine and coarse bone, multiply these percentages by their unit value and add together the products:—

Nitrogen	...	...	3·16 per cent.	×	$\frac{42}{100}$	=	1·32	as fine bone.
Do.	...	...	3·16	„	×	$\frac{58}{100}$	=	1·833 as coarse bone.
Phosphoric Acid	...	...	20·20	„	×	$\frac{42}{100}$	=	8·48 in fine bone.
Do.	...	...	20·20	„	×	$\frac{58}{100}$	=	11·71 in coarse bone.

Per cent.	Unit Value.	Value per ton.
		£ s. d.
1·32	× 16/-	= 1 10 0
1·83	× 14/-	= 1 5 9
8·48	× 5/-	= 2 2 5
11·71	× 4/-	= 2 9 9
Unit Value	...	£6 19 2

It is thus seen that the price per unit is obtained by multiplying the percentage of each ingredient by the price of a unit, or conversely by dividing the price per ton by the percentage of the fertilisers and adding together the products.

In this manure the purchaser can arrive at a fair value of the manure offered to him, to which, of course, must be added the cost of carriage from the manure works.

#### EFFECT OF FERTILISERS ON FRUIT CROPS.

Experiments made a few years ago in the State of Missouri brought to light the fact that twigs, fruit spurs, spurs with fruit set, of apples, analysed, showed that the much larger amount of lime, phosphoric acid, and potash in the bearing twigs is very marked as compared with non-bearing twigs. It would thus seem that the effect of fertilising fruit trees cannot possibly manifest itself in the same year in an increased fruit crop, but appears to a certainty the year after, and that fruit growers, in valuing fertilisers, must bear this in mind to arrive at a correct conclusion of the action of manures on their fruit crop.

Speaking in a broad sense, nitrogen, applied as a fertiliser, produces wood and leaves; phosphates produce fecundity and a brightness of colouring; and potash produces sweetness and flavour; gypsum and sulphate of iron help to fix the fruit on the tree.

An abundance of nitrogen is indicated by rank growth and dark green foliage, and by size and coarseness of fruit. Conversely, stunted growth and pale leaves often show lack of nitrogen; fewer fruits are formed; these are of smaller size and colour early. On oranges, excessive organic nitrogen results in thick rind, abundant rag, and sometimes in causing defoliation, die-back, and gumming diseases.

Lime and potash correct the effect of heavy doses of organic nitrogen.

Mineral nitrogen stimulates the production of fruit more than excessive applications of organic nitrogen. In oranges, thinner skin and little rag or fruit pith is produced; sulphate of ammonia, when there is a slight deficiency of potash, tends to sweeten the fruit.

Phosphoric acid starvation is at times manifested by the appearance of the young and tender leaves, known as "frenching" or variegations of the foliage. Phosphorus throws the tree into fruit quicker and has a most beneficial influence on the growth of the plant.

Potash fertilisers are not sufficiently used by fruit-growers, considering what an amount of this element is found in the ashes of fruit.

Heavy doses of potash, unless correspondingly accompanied by other fertilisers, produce sour fruit. Lack of potash is shown by spindly growth of wood, which summers badly and is easily injured by frost. On account of its hygroscopic property, good results have been obtained in applying it in early spring to aid the plant in withstanding the spring drought, which often causes a great quantity of fruit to drop off. A yellowish, unhealthy condition of a tree is often caused by the application of a potash fertiliser.

Lime is notable in its effect on table grapes. It also tends to hasten the ripening and perfect the colouring of oranges. Deficiency of lime is often accompanied by thick skin and poor aroma.

#### WHEN AND HOW TO MANURE.

The question is often asked: When is it best to apply fertilisers? Phosphates may be applied at any time from the beginning of the autumn up till the end of the winter. Potash is better applied early in heavy soils, which it has a tendency to clog, so as to give the winter rains and the frost time to counteract that particularity. The application of lime with it will also correct this tendency. On light dry sandy loam it is advisable to apply potash fairly late, so as to utilise this hygroscopic feature towards storing up moisture in the vicinity of the roots of the plant. Nitrogenous chemical fertilisers it is better to apply in the

early spring amongst deciduous trees, and before the trees bloom. In regard to evergreen trees, such as those of the citrus tribe, it is immaterial at what time, so long as the trees are systematically and regularly fed. It is recommended for citrus trees to divide the amount of chemical nitrogenous manure to be applied during the year into two applications.

Experience will teach the orchardist how to regulate the spread of any quantity of the manure whilst covering an acre of land.

The following rule-of-thumb practice is found to be fairly correct for such fertilisers as potash salts, and nitrate of soda, sulphate of ammonia, or any fertiliser of approximately the same weight.

In broadcasting, sowing a handful at each step, the right foot steps forward, and scattering it 12 to 15 feet in breadth, there will be applied 150 to 200 pounds per acre.

Non-soluble fertilisers, such as bonedust, if sown by themselves, it is preferable not to sow broadcast for the manuring of orchard or vineyards, as this practice draws the roots from underneath to the surface, where they are periodically hacked about by the tines of the scarifier. A better plan is to set the plough to its full depth of 8 to 9 inches and open a furrow up and down the centre of the land between the two rows of trees or vines and sowing in these deep gutters the amount of insoluble fertiliser it is meant to give to each acre of land. When this is done, the plough is again set to its proper depth and the earth is thrown back on to the manure, which is thus buried under. Should the land be too stiff, or the team too light for opening such deep furrows, the plough can be run once again in the bottom of a first top furrow, and the requisite depth is thus attained. In this manner numerous small rootlets issue from the severed roots of the plants and go and feed on the manure in the deep trough, twisting and coiling around each particle. When trees are manured by means of insoluble fertilisers, dig with the spade, some three to four feet from the stem, three trenches a foot deep and several feet long, in the form of a triangle; place the manure at the bottom of these trenches and cover up with soil. When manure is forked into the ground, it should not be applied right against the bole of the tree, but a small distance away. The plate in the article on mulching illustrates the distribution of the main roots and of the rootlets in the ground. The first, whose main functions are to brace up and support the structure, is fairly barren of rootlets; they give rise to branch roots which, in their turn, carry towards their periphery the fibrous rootlets, which are in a true sense the feeding mouths of the plant, and absorb the moisture and food required by the growing tissues. The diagram shows where water and manure should be applied and where mulching does most good.

## EXPERIMENT FOR YOURSELVES.

Chemical analysis of a soil will indicate on broad lines the wealth or the pooriness of a given soil, but its teachings are in no wise as accurate as those derived from personal observation drawn from the result of local experiments. Growers can, with little or no trouble, find out for themselves the elements that are more urgently required by their trees. For this purpose, a row or two are set apart, every third tree is manured in some manner or other; the trees on each side of it are left unmanured, as witnesses to show by comparison whether a manured tree greatly differs from them or not. Some form of nitrogenous manure may be applied to one or more of the trees in the experimental line; then some form of phosphatic manure to one or more others; then again, some form of potassic manure to one or more trees. The experiment can further be widened by combining together for testing on some fresh trees any two of the manures used singly on the first lot of trees, and finally more trees are tested with a complete fertiliser, resulting from the combination of the three fertilisers used singly, or of any fertilisers containing in some available form the three elements—nitrogen, phosphoric acid, and potash.

One thing the grower must well penetrate his mind with, that crops, like animals, must be generously fed to keep healthy and bear abundant crops. Just as the digestive organs of the animal assimilate the nourishment of its body, so the assimilating organs of plants utilise the food placed within their reach. Like the animal also, they require a "complete ration;" that is to say, one with no needful element of plant food lacking, and when well fed the plant will thrive, produce without effort, and withstand and offer no encouragement to the numerous parasitic pests that assail our cultivated crops. Spraying and manuring operate conjointly, and well-fed trees, once freed from parasites, remain clean without further dressing for a very long time. The varying state of health and vigour in even a small 10-acre orchard, when the climatic conditions are otherwise alike, point out to variations in the constituents of the soil.

## IRRIGATION AND ROOT MANAGEMENT.

## HOW PLANTS ABSORB WATER.

Plants, flowers, and fruits are made up mostly of water. Analysis shows that there is as much as 90lbs. to 94lbs. of water in every 100lbs. of some of the more succulent fruits and vegetables, such as asparagus, cabbages, cucumbers, lettuce, melons, rhubarb, tomatoes, and strawberries; as much as 80lbs. to 85lbs. of water in every 100lbs. of such fruit as apples, apricots, grapes, lemons, and pears; green fodders contain 60 to 85 per cent. of water according

to their state of maturity. According to Professor King, of Wisconsin, it requires 300 to 500 lbs. of water to produce 1 lb. of dry vegetable material, or in other words, to produce 1 ton of hay, it is necessary to have 300 to 500 tons of water, which must be supplied by rain or by irrigation during the growing period; so it 1 ton is to be grown on an acre there must be from 3 to 5 inches of water supplied at the proper time. (The weight of 1 inch of water over 1 acre of land approximates 100 tons.) It is essential that the contents of the cells which enter into the structure of the growing plant should be in a half-liquid condition in order that nourishment and construction material should be carried and distributed wherever required, be it in the stem, the tender buds, or the ripening fruit. When the cells cease to be distended with fluid sap they get flaccid and the plant wilts. Unless this state is promptly remedied by an influx of sap these cells thicken, they lose their elasticity, the plant first gets stunted and finally dries up and dies. The water necessary for plant growth is absorbed by the hair-like rootlets issuing from the stronger roots which penetrate the ground in search of food and moisture; it does not, however, enter into the circulation of plants quite pure, but contains in solution variable quantities of substances which plants feed upon. From these rootlets it is passed on from cell to cell, by a process of diffusion, first along the larger roots which anchor the plant to the ground, thence to the stem, on to the branches, the buds, leaves, and fruit.

That cell to cell motion, or that diffusion of the nourishing sap, from the capillary rootlets to the tip of the branches, is quickened by evaporation.

The evaporating organs of the plants are the leaves. These, when fanned by the breeze, allow a considerable amount of moisture to escape through the stomata or breathing pores. In bright daylight these pores open to allow the admission of carbon and of oxygen to the working cells of the leaves. As this takes place a good deal of the moisture which saturates the air in the intercellular spaces of the leaves escapes to the drier outside air. A vacuum is thus created, and more moisture exudes from the gorged cells to replace the amount lost through evaporation. In this manner a current of sap is created from the rootlets upwards towards the branches.

Under certain circumstances this current may run quicker than the plant is able to absorb moisture from the ground. This is noticeable on a dry, hot day, when the plant flags.

This being so, it is easy to understand that other conditions of soil texture and of particular plant requirements being alike, a given field crop, or trees of the same sort and age, will show signs of wilting and need for water much sooner in the drier air of the inland districts than in the moister air of the coastal zone. In both instances the soil may have been wetted to saturation point by the

winter rains; but, evaporation being more active inland than on the coast, that store of moisture is more rapidly exhausted in the first instance as compared with the second.

This perspiration of the leaves keeps the plant cool when everything else around is scorched, but as soon as that perspiration ceases leaves and fruit get burned. Whenever, therefore, perspiration threatens to stop for want of moisture rising from the roots we find in watering and in irrigation a ready means of stimulating it.

#### ADVANTAGES OF IRRIGATION.

In the coastal districts of Western Australia, where fruit-growing is more generally carried on, little or no heed has, until some nine or ten years ago, been paid to the advantages of irrigation. The reason is that within that zone which is more directly under the beneficial influence of monsoonal and maritime climate, that climate is consistent and not capricious. The ground receives a deep and a thorough soaking every winter, and the air is, except in the latter part of summer, charged with a sufficiency of moisture which checks a too rapid or too prolonged evaporation or perspiration through the leaves. Further inland, however, these conditions are not noticeable to the same extent. The rainfall is not so abundant and the evaporation is greater; furthermore, adequate and suitable water for irrigation is often deficient.

Numerous spots, however, are found dotted over the country where irrigation can be applied with profit. In such places, and wherever deep and thorough drainage is associated with it, irrigation eliminates any risks arising from any freaks and anomalies of the season. Such privileged spots are always, for that reason, much sought after. Although alive to the value and potentialities of these spots, few owners have hitherto taken advantage of their sources of water supply and led them along suitable channels to where they can double or treble the production of the ground.

It is greatly due to the exertions of Mr. H. Scott, who some ten years ago was appointed to organise and take charge of the Irrigation Branch of the Department of Agriculture, that the benefit of applying water to growing crops of fodder and fruit trees has been brought under the notice of settlers in this State. A special Bulletin, prepared by Mr. Scott, can be obtained on application to the Department of Agriculture; the questions involved are more fully treated in that publication than it can be in this chapter, and those desirous of gaining further information must be referred to it.



Water channels on graded land.



## EVILS OF IRRIGATION.

Although irrigation has been a source of large profits to some, it may be said to have, on the other hand, led in as many cases to considerable losses. The practice should only be adopted with judgment and after consultation with the specialists in charge of that work at the Department of Agriculture. The initial cost of leading water on to the land may be so great that the expenditure may not be justifiable. Moreover irrigation without efficient and thorough drainage is always fatal, sooner or later. The ground thereby alternately gets chilled and baked; there is no get away for the water except by evaporation; this cools the ground to a point which is uncomfortable and detrimental to vegetation and leads to the rotting of the roots. In irrigating or watering an orchard, the water should never be led or poured into a cup-shaped bowl, dug around the stem. This causes a gummy exudation to ooze out at the crown of the tree, and the plant dies of collar rot. The stem should always be protected from actual immersion in water by a small mound of earth which is banked up around it.

Irrigation on ground which is not naturally well drained, or where no attempt has been made to deep drain the soil, is often the cause of the displacement of masses of injurious alkaline salts from deep down towards the surface, where they finally accumulate and corrode the roots and stem and kill the trees. Much valuable information on this rising of the soluble alkalis in irrigated soils is due to Professor Hilgard's researches in California. It has been shown that the presence of as much as a quarter of one per cent. (.25 = 8,750 lbs. on one acre of soil 1 ft. deep) of carbonate of soda, one of the most corrosive of soil alkalies, renders that soil sterile.

Over-irrigation is one of the greatest causes of failure in the hands of the amateur irrigationist. In a climate like ours, where the ground is well soaked during the winter months, there is little need to water the trees until early in summer if on deep loamy ground. Two or three more thorough waterings at intervals of a month, followed up by thorough cultivation and pulverisation of the surface ground, would thence meet the requirements of most trees.

A good soaking is better than two or three niggardly waterings, which, instead of encouraging root growth deeper down into the soil, attract the tender rootlets towards the moistened surface, where they lie exposed, to be hacked about by implements of cultivation, or to be dried up should a hot, dry spell of weather set in.

Water cannot be forced into the ground. Sufficient time must be allowed for it to soak, generally 12 to 24 hours.

The benefit derived from irrigation is often annulled by neglect to suitably manure the land. It stands to reason that, if a soil can supply the necessary plant-food for half-a-dozen successive crops of, say, two tons of fruit to the acre, without showing any need

for a supplement of that food in the shape of manure, it will, when producing, say, four tons of fruit, when put under intensive culture, with the aid of irrigation, show signs of falling off much quicker than it would otherwise have done.

The belief that a crop is all right because it has been irrigated, unfortunately proves only too often a delusion. Unless the operation can be carried out at a reasonable cost, with suitable water, on well-drained ground, properly manured, and provided the operation is not overdone, irrigation cannot be profitable. It is also essential, when orchards and vineyards are concerned, that the pruning and thinning operations should receive proper attention, and that pests and blights should be vigorously suppressed and not allowed to share with the owner the surplus crop which irrigation carried out under favourable circumstances always ensures.

#### WATER MEASUREMENT.

The cultivator who handles water must be able to determine fairly accurately the amount of water needed for a crop on a given soil, and a few figures in relation to the measurement of water will be helpful in calculation:—

- 1 gallon of water weighs 10lbs., and measures 277 cubic inches.
- 1 cubic foot of water weighs 62½lbs., and contains 6¼ gallons.
- 1 cubic yard contains 169 gallons of water.
- 1 ton of water contains 224 gallons, and measures 36 cubic feet.
- 1 inch of water over an acre of land weighs 101 tons, and therefore means 22,624 gallons, an amount which would be held in a tank with a 3,600 cubic foot capacity. A square tank 15ft. x 15ft. x 15ft. would about hold this quantity or, nearer still, a tank 18ft. x 20ft. x 10ft. = 3,600 cubic feet.
- A miner's inch is the amount of water running from a hole one inch square with a head pressure of 6 inches in one second or one minute.

#### WATERS FIT FOR IRRIGATION.

Water is the universal solvent, and no water except that trickling from the condenser of a distilling apparatus is absolutely pure in its natural condition.

Thus rain water, which is considered the purest of all, washes down from the air impurities which to a great extent constitute valuable plant food. In close proximity of the sea coast, for instance, 30 to 40lbs. of common salt to the acre are brought down

annually by the rain. Of ammonia 2 to 10lbs., and of sulphuric acid 10 to 20lbs. are added from the same source to every acre of land in localities favoured with a fair amount of rain.

Of stream water some prove better than others when used for irrigation, and they vary according to the amount of substances they carry either in solution or in suspension.

Well water is, as a rule, even more highly mineralised than stream water, and is often injurious to vegetation, especially in the Eastern and inland districts, where it is not infrequently unfit for consumption.

Taste is the readiest means of ascertaining whether water is fit for domestic or irrigation use.

A crystal clear well water often proves worthless for irrigation purposes, whereas a spring or a well well-stocked with aquatic plants and luxurious vegetation, and where stones at the bottom are covered with green slime, always holds water fit for irrigation.

The best indicator of the fitness of water for irrigation is the palate, and when the taste is decidedly mawkish it is advisable to have a sample analysed before going through the trouble and the cost of providing for its lifting and cost of distributing it on the ground. An analytical statement is often perplexing until the array of figures is understood.

In water analysis the residue or solid matter either held in suspension or in solution is expressed in so many grains per gallon, or so many parts in 10,000 parts. We have seen in a previous chapter when dealing with manures that the weight of one acre of agricultural soil one foot deep is approximately 3,500,000lbs. It has, moreover, been determined by chemical investigation that a soil containing .1 per cent. of soluble salt is unsuitable for cropping, and is only fit for growing salt-loving plants.

The question, therefore, which the irrigationist has to solve is: What amount of water containing a given quantity of salt will be necessary to cause the accumulation into the ground of approximately .1 per cent. of salt (equivalent to 3,500lbs. to one acre one foot deep)?

That question, indeed, can only be approximate, as a certain proportion of that saline matter would be leached out of the ground during the rainy season; sandy soil could, besides stand more salt than the more retentive soils, such as loam or clay, and drainage would also delay to some extent the period when that dangerous point of .1 per cent. of salt would be reached. When calculating the amount of salt added to the soil by water containing a known number of grains of that substance to the gallon, it must be borne in mind that one gallon contains 7,000 grains. As 1 inch of water over 1 acre is equivalent to 22,630 gallons (101

tons) it follows that every grain of salt per gallon adds  $\frac{22630}{7000} = 3\frac{1}{4}$  lbs. of salt to the ground whenever that amount of water is used in irrigation.

It would be unsafe to use extensively and continuously for the purpose of irrigation a well or pond water containing more than 70 grains of salt to the gallon. Such an amount would mean an addition of about 2cwt. (227½ lbs.) of salt to the acre, for each one-inch watering. Such a water used in the more arid regions, where rainfall is light, would soon accumulate in the surface of the ground an amount of salt which would prove injurious to vegetation, and 10 irrigations of one inch each would add to the soil over a ton of salt, which, added to the amount of that substance already in the ground, would make it sterile unless the soil is light and the drainage efficient.

In the coastal districts, where the rainfall is more abundant, a water containing 50 grains of salt to the gallon could be used pretty freely for irrigation, provided the soil is of a light and porous nature and is well drained. But if used on stiffer soil it would, in the course of a few years, bring the amount of salt up to danger point.

A water containing 10 to 12 grains of common salt to the gallon is often used for all domestic purposes.

In a previous chapter dealing with the limits of salt in water the maximum amount of chloride of sodium in potable and stock water and water for irrigation, as suggested by Mr. E. A. Mann, the State Analyst, is given more fully.

#### FACTORS WHICH INFLUENCE IRRIGATION.

No cast-iron rule can be laid down regarding the amount of water necessary for obtaining the best results from a given crop.

The rainfall, the depth and nature of the soil and of the sub-soil, the particular variety and age of the trees, the climate, the quantity as well as the quality of the water at command, and the means and facilities of bringing water on to the land all require consideration.

Speaking generally, a rainfall of 20 inches on deep loam fairly rich in vegetable matter, and possessing good absorbing and retentive power, may prove sufficient for an orchard planted with deciduous trees, provided that amount of moisture is well tended, and by good cultivation prevented from escaping by evaporation.

Under similar circumstances, 25 inches may do for evergreens, such as citrus trees, which require more water.

On deep, dry, sandy, or limestone formation, however, or on thin soil overlying solid rock, the plants would very likely show signs of distress even with a greater amount of rainfall,

Crops possess different degrees of thirst, their exigencies in this respect running approximately in the following order:—

1. Meadows and artificial pastures.
2. Maize and sorghum, for green crop.
3. Lucerne.
4. Rape and root crops.
5. Tares, oats, and peas.
6. Fruit trees.
7. Wheat and rye.
8. Grape vines.

In the course of an ordinary season, the climate and the soil of the bulk of the South-Western division of Western Australia has been proved to possess sufficient rainfall and sufficient absorbing and retentive power to supply all requirements of the last four of these groups of cultivated crops. After a dry season, however, even these more pronounced drought-resistant crops will suffer more or less, and fail to yield a full crop, except at especially favoured spots, or unless artificially watered in the proper season.

Under the climatic conditions experienced in the moister parts of the South-West of this State different crops would require watering at different intervals.

For summer crops, the seed bed must be moist, otherwise apply water before or after ploughing with a second watering a fortnight after sprouting, and a third in another four weeks or so as the season requires.

For fruit trees, two or three waterings for vines and three or four at most will do for fruit trees.

For Lucerne a watering immediately after each cutting and then harrow. This, with favourable conditions, may mean five waterings or more.

For market garden crops, more frequent, but lighter waterings.

The volume of water varies with the kind of soil and with the rooting character of the crop. Tomatoes and Lucerne, for instance, require different volumes. The most usual depth is 7 inches, but it may vary from 3 to 20 inches.

The age of trees, too, and the distance apart they are planted, influence to a very marked degree their moisture requirements. Evidence is not lacking of a number of orchards established in various parts of the country which, when young, produced crops of first-class fruit, and which as the trees became older and the space between the trees decreases with their growth, bear a class of fruit inferior in size, appearance, and flavour. In such instances watering often proves very profitable. It is simply reduced to a question of ways and means.

Irrigation water cannot bear a high rate. This amount is capable of variations according to localities and the market value of the produce it is proposed to raise, rates ranging from 1s. to 4s. per 1,000 gallons. With shallow wells, and the larger size windmills, water can be elevated for 2d. per 1,000 gallons; the life of the windmill, cost of well, and overhead tanks being practically the only expenses.

At Mildura the quantity of water taken varies somewhat with the class of soil, but, generally speaking, it may be assumed at six inches per watering. The dates of watering usually commence in August, October, and December, lasting five to seven weeks. A fourth watering for crops and citrus is given in March-April. For vine land and fruit trees the rate struck this year ('19/'20) ranges from 45s. to 60s. per acre per annum for three waterings; crop land being given two waterings at a reduction of 10s. per acre.

#### METHODS OF IRRIGATION

differ with the nature of the crops grown. As a rule, the method of flooding land is practised in the case of pastures, meadows, and cereal crops, whereas either *permanent ditches* or *fresh furrows* are resorted to in watering orchards, vineyards, or crops grown in lines.

In this second case furrows are traced each side of rows running from the distributing channels down the slopes. On steep and broken slopes difficult to plough and where the soil is apt to wash, permanent ditches are laid out on gentle grades for slow running of the water, which slowly percolates from these ditches and supplies moisture to the trees or crops below them. The great drawback of this system of watering land is that a considerable amount of hand-hoeing has to be done on the banks of the furrows, which not being turned up by the plough, would soon be covered with a thick growth of couch grass and weeds. For this reason, and on level land, wherever the land has been well graded and levelled, as it is the practice on most irrigation colonies, the fruit trees are watered by means of plough furrows, which are closed after each watering. Where the grade is steep, a shovelful or two of earth thrown at intervals in the channel will break the current of the water. As soon as the water has reached the lower end of the furrow, the watering may be stopped altogether and other furrows filled; or should a good soaking be required, one-half or two-thirds of the water should be cut off and smaller streams allowed to trickle a few hours longer, until the land has been sufficiently moistened. A rapid flow of water along the distributing furrows will glaze the surface and will prove an obstruction to the water soaking deeply down into the ground.

The *Supply Furrow*, which is fed from the *Main Channel*, is made to run along the highest side of the ground and supplies the water to the *Distributing Furrows*, which are made to run perpen-

dicular to its direction. It is easily made by running first an ordinary plough, which traces the furrow and is followed by a double mould-board or ridging-plough, which not only opens up the channel, but throws the loose earth on both sides so as to form the bank. Should a deep channel be required, this operation is repeated over again.

The *Distributing Furrows* are easily traced by running an ordinary single furrow plough up and down the same furrow.

It is important that the water should not come into actual contact with the bark of the trunk, as trees which have thus been standing in water for some time are apt to develop the "collar rot," which is an exudation of sap at the root crown, and is very similar to the gum disease. Many a promising young tree has thus perished through being improperly watered. For this reason, water should not be applied to the trees in the bowl-shaped reservoirs which beginners often think is the best way of watering them; whenever water is thus applied a little mound of earth should be left as a protection round the trunk. Another reason why water should not be thus applied is that in order to be more beneficial, it should be placed within easy reach of the tender rootlets which radiate round the plant, and to which it is most beneficial. I have already called attention to the structure and disposition of the roots of the plant round the stem, so that the reason is plain why it is more beneficial to water the plant at some distance from the trunk, where all these tender rootlets radiate, rather than close up to the plant itself.

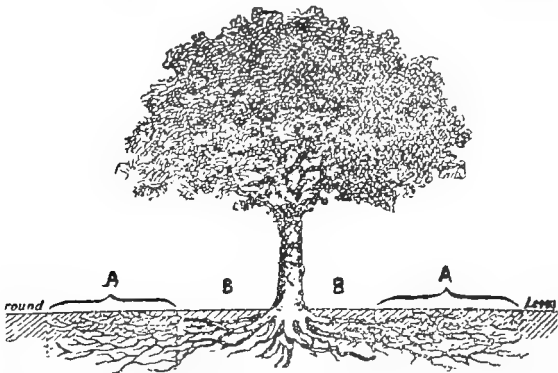

Showing at "A" the proper place to mulch, manure, and water.

The distance of the furrow on each side varies according to the size of the trees.

For young vines a furrow on each side 18 to 24 inches away from the lines might be drawn, whereas for older vines planted

8 to 12 feet apart in a loamy soil one furrow midway between the rows is quite sufficient.

For young trees the distance from the trunk would vary from two to three feet, and if the trees are large the furrows would be opened four to six feet away from the stem.

Whether the soil is heavy or light, the method of applying water is the same, and the next day or the day after, as soon as it is sufficiently drained, the whole surface is scarified with the cultivator; or if the surface is already clean and loose, the furrows alone are broken up by means of the cultivator or scarifier, which should not be less than three feet wide, so as to take in a good strip of land.

At each subsequent irrigation the furrows are run in a different place, and thus is the land maintained into a uniform degree of moisture.

#### SPREAD OF WATER FROM DEEP FURROWS.

In an ordinary soil 1 inch of water will saturate dry soil about 3 inches deep, though moisture will in a few days reach several inches farther and give the ground the appearance of being wet when it is very much below the point of saturation and could retain considerable additional moisture.

When the ground is first irrigated, large quantities of water are sometimes needed to saturate and settle the subsoil. This settling of the subsoil is sometimes so great that it is necessary to go over the tract and regrade it.

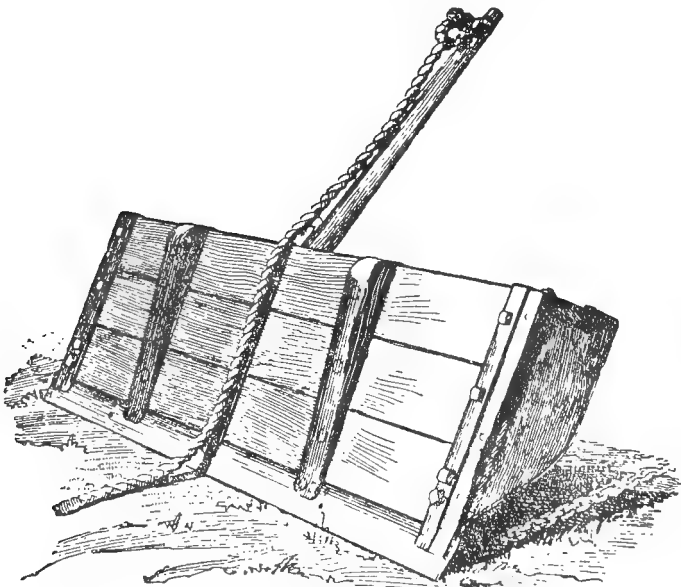

Buck Scraper tilted up when unloaded



Clay and sand will absorb water at a different rate, and, having absorbed it, hold and retain it more or less loosely.

These properties have been measured at the sub-stations of the College of Agriculture of the University of California, and the following diagrams show the extent to which water from fairly deep furrows penetrates the sandy soil and the heavy loam at the sub-station.

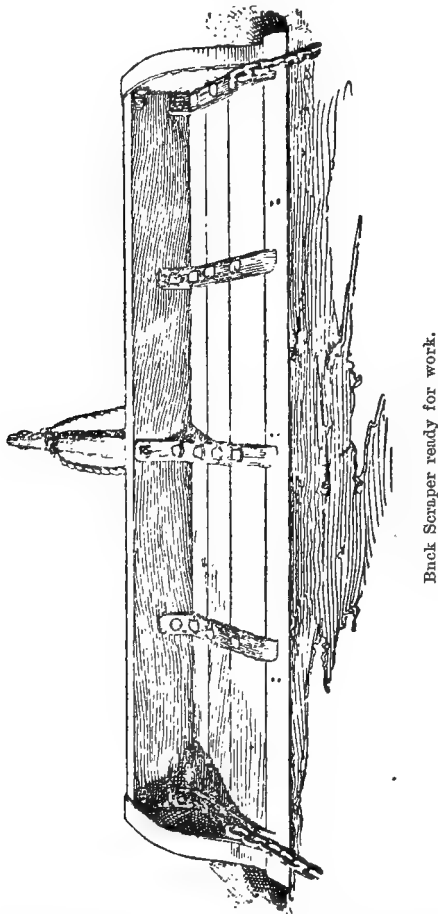

The spread and the descent of water are carefully mapped out on these charts.

The furrows are seven inches deep, and the water was run two days of twelve hours each. Seventy-two hours after irrigation the extent of soil-saturation was measured, the sectional area showing

that in clay water had wetted somewhat under sixteen square feet as against about thirty square feet in the case of the lighter, more porous soil. It is contended that a still deeper and narrower water channel in the case of the clay soil would have carried the water deeper, and would have resulted in economy in the use of water, a smaller flow producing as large an area of saturation with less surface.

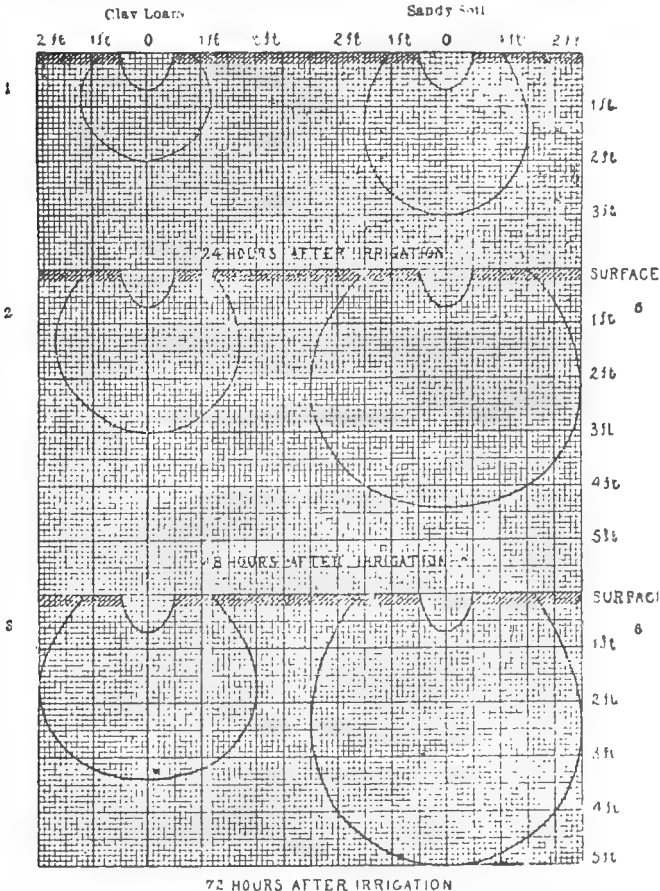

Percolation experiments, showing spread of water from deep furrows in clay and sandy soils.

*Cost.*—It is reckoned that with one horse and plough one man can prepare ten acres for irrigation in a day at a cost of 12s. 6d., or 1s. 3d. per acre. With a scarifier six feet wide and a pair of horses, one man can cultivate the same area of ground after each watering at a cost of 15s., or 1s. 6d. per acre.

## AMOUNT OF WATER REQUIRED.

No hard-and-fast rule can be laid down. Local experience, as well as the general appearance of the crop, are the best guide in this matter; for instance, the amount of rainfall varies sometimes considerably even in the same seasons in different years; again one soil may be more retentive than another; or, owing to its configuration and the more or less porous and gravelly nature of its sub-soil, may either be very quickly drained or else may receive abundant moisture from the drainage of the slope above it; the varieties and age of the trees have also a direct bearing in regulating the amount of water to be applied; thus certain soil will be quite moist enough for deciduous trees, such as plums, apples, pears, and would require irrigation for citrus trees, or moist enough for young and not for bearing trees. In a very dry climate, for instance, the young orange orchard should be irrigated every three weeks at first, and then once a month during the first season by simply running one furrow at a distance of two or three feet on each side of the trees.

The second and third seasons, the trees having been well established, less irrigation will be required, and in our climate one watering every six to eight weeks will be sufficient.

By the fourth year, the trees having gradually increased in size and being in bearing, the number of furrows between each row will likewise be increased until, when the trees have grown to their full size and produce heavy crops, by the tenth year, the distance between the furrows is brought to five or six feet and the time given for each watering is gradually prolonged. As a rule, orange trees in full bearing will require as much as three times the quantity of water required by the same trees during their second and third year in the orchard.

In the case of the vine, the water management also requires judgment. During the first season of planting, one or two good waterings are more than will be needed, the ground having received a good soaking previous to planting out the cuttings or the rooted plants. The second season, one early autumn and one summer watering will be found sufficient, and later on as the vines enter into bearing they should not be irrigated more than once every five or six weeks in the case of table or raisin grapes, and once every six or seven weeks in the case of wine grapes. In either case, the watering should cease when the berries have attained their full size and are ripening, or else they will burst, viz., according to localities and varieties, the beginning of December to the beginning of February. In the case of wine grapes, the last irrigation should not be given later than the time the grapes are "turning," or otherwise the must will be watery and the wine will be thin, poor in colour, in flavour, and in keeping qualities.

Over the fruit-growing districts of this State, described in this handbook, grape vines do remarkably well without the assistance of any irrigation whatever, provided the soil is kept in a state of good cultivation.

So far as I have been able to observe, the tendency generally with fruit growers who have water laid on in their orchards is to overdo irrigation. Fruit trees more especially need to be irrigated with discrimination, or else the fruit, instead of being firm, fleshy, of good flavour, and of good keeping quality, is, on the reverse, spongy, squashy, insipid in taste and flavour, easily bruised during the course of carrying to market, and of poor keeping quality.

In planting an orchard where irrigation is contemplated, the grower should bear in mind that each variety of fruit requires watering at different times; for instance, watering with cold water when the tree is in full blossom might lead, through sudden shock, to considerable injury, and, as a consequence, reduced crop. With trees, therefore, blossoming at different times it is advisable to keep them separate; again each row should be planted with trees of the same age for reasons already discussed. Another reason is that by keeping the trees separate each sort may be treated differently, some kinds of fruit requiring more copious watering than others.

Late in the season the irrigation of fruit trees might be more injurious than beneficial, for the reason that the soil and the water beginning to cool, the trees might receive a sudden shock, or they might start growing again, striking new shoots, instead of concentrating all their energy towards ripening the fruits and building up fruit buds.

One more important point, if neglected, would annul the benefits derived from irrigation.

It refers to the necessity of combining *Drainage* with irrigation. Unless the soil is naturally well drained a copious supply of water will turn it into a quagmire, which will prevent proper cultivation and at the same time injure the roots of the trees.

It may be said that wherever land is so situated that natural drainage does not exist and the cost of sub-soil drainage would exceed the value of the profits expected from the application of water on to the land, irrigation is unprofitable; otherwise, underground drainage may be said to remove the excess of moisture in winter, and to tend to retain it in the summer months, thus making the soil, and consequently the roots, warm when the weather is cold and cool in dry and hot weather. Complete drainage and moderate moisture are as necessary to the healthy growth of the root system of the plant as pruning and spraying with insecticides to the healthy growth of the branches and leaves, and the production of a crop of sound, showy, and well-matured fruit.

## WHAT FRUIT TO GROW.

The following chapter contains a carefully-selected list of fruits which have either been proved to be successfully grown in the S.W. division of Western Australia, or are known to thrive in other fruit-growing countries bearing, with ours, strong features of similarity as regards those natural conditions which are congenial to fruit trees.

The letters E., M., and L. mean early, medium, or late respectively, and S., A., and W. denote summer, autumn, and winter; F. and C., freestone or clingstone.

## PLANT BREEDING.

Until a few years ago the art of man had seldom been directed towards improving our cultivated plants. Seeds were collected of varieties exhibiting special features deemed worthy of reproduction and improvement. These were planted under favourable conditions and received the benefit of careful cultivation; the rest was left to Providence. Under such circumstances, a great many of our choicest select seedlings, varieties of fruit trees, and plants have originated; a great many more are the result of chance seedlings. This process, however, is, if at times efficacious, somewhat empirical, and some of our more modern fruit growers have of late brought their commercial genius to bear in selecting and in mating varieties embodying special features which, when blended together, would approach closer to the ideal they have set themselves to create. Time is thus saved, and if the result does not always come up to that ideal, it often constitutes a subject which is worth putting to the test, and which is finally adopted or rejected by either the breeder himself or by the cultivator.

This is effected by the process of cross fertilisation or of pollination. For so doing something must be known of the structure of the flower. Inside the corolla, which is formed of the variously-coloured petals, are the organs of fructification of the plant. These consist of a pistil, so called because it somewhat resembles a pestle, and which includes an inflated tip or stigma which receives the pollen, a style or miniature tube which conveys the pollen to the ovary, which in the course of development becomes the fruit. They also consist of thread-like bodies called stamens, which are the male organ of flowers and surround the pistil. These organs secrete the pollen or fecundating dust which is contained in little capsules called anthers.

The appliances necessary for cross-fertilising plants are a pair of long-pointed scissors, a pair of tweezers, a magnifying glass, and paper or gauze bags.

Soon after the blossom opens, the petals of the corolla may be removed; the stamens which surround the pistil are excised on those flowers of the plant it is intended to use as the foster-mother of the

#### POLLINATION.

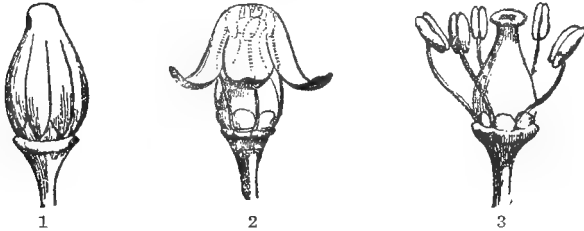

FIG. 1.—A grape vine floral bud.

FIG. 2.—Same showing the petals of the corolla detached from the base and united above, pressing the anthers against the pistil.

FIG. 3.—Same with the corolla removed, and showing the anthers ready for excision.—(FOEX)

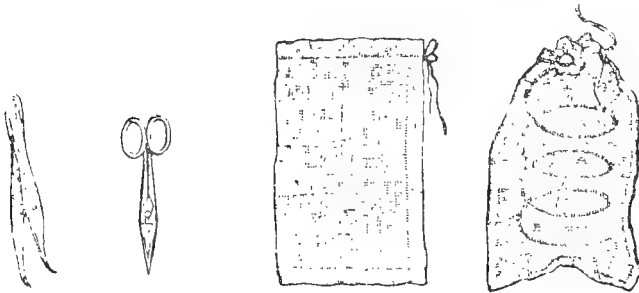

FIG. 4.—Tweezers and scissors. Gauze bag. Same expanded by wire frame.—(FOEX.)

new variety, and the paper bags, whose edges are damped slightly and tied on the twig supporting these organs. This done, the blossom on the parent tree which is to supply the pollen is watched with the aid of the magnifying lens, and so soon as ever the pollen sacs are seen to begin bursting, these flowers may be cut, seized with the tweezers, and after carefully lifting the paper bag from the blossoms with the male organs excised, they are gently rubbed on the exposed pistils; the covering bags are then fastened on again and left to remain for a few days until the setting takes place.

#### PEDIGREED FRUIT TREES.

The individuality of the tree having been secured, either accidentally or owing to the foresight and the experience of the breeder,

it can be transmitted and preserved with a fair amount of permanency. Some strains of cattle and live stock are well known which embody to a high degree of perfection all the good points of the breed, whilst other strains are also known to have thrown back and degenerated and to only beget mongrels; so in our orchards there are strains of vigorous and of feeble trees bearing, some heavily, others lightly. This being admitted, the importance is plain to only propagate from the most productive and the best. After individual trees seemingly inferior to the accepted standard have failed to improve under the stimulus of cultivation, manuring, suitable pruning, and treatment, there is but one thing left to do, and that is to cull it out and work on it a scion from some selected strain.

#### CROSS POLLINATION OR FERTILISATION.

Experience has shown that fruit trees, other things being equal, bear better when varieties are mixed in the orchard. This is strikingly true in the case of the almond, stone fruit, apples and pears.

Mr. J. Hawter, of the Blackwood Nursery, who noticed the benefit in bearing to the other trees, recommends planting varieties blossoming about the same period in alternate rows of 2 to 6 right through the orchard, thus:—

“Start with 3 rows Jonathan, 2 rows Dunn’s, then 6 rows Jonathans, 2 rows Dunn’s, and repeat the 6 and 2 to end of block. One row would do every 6th row, but it means a waste of time at pick-

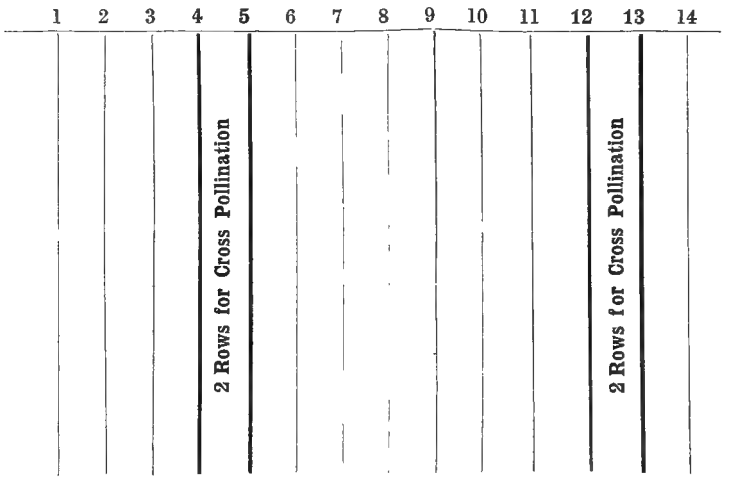

ing, as varieties do not ripen together and cart has to go round to pick up, and I recommend the double row as the more economical system, although mine are planted in alternate rows, and hence speak from experience.

"The importance of cross-pollination induces me to give in my Catalogue, the approximate dates of principal varieties of apples and pears being in full bloom, compiled from my observations the last three or four years. I am also indebted to the Department of Agriculture for kindly placing their data collected at Bridgetown at my disposal, and I trust these approximate dates may be of assistance to intending planters in making their selections with a view to interpollination.

"The above sketch explains my recommendations where preference is given to one variety. I shall be pleased to recommend suitable varieties for pollination on application."

### POME TREES.

These are commonly meant to comprise fruit grown from pips, such as apples, pears, and quinces.

They were some generations past known by country folk as pippins, pearmains, russets, costards, codlins, and so on.

"Pippins" were chance seedlings which were in themselves so perfect that they did not require grafting or budding. "Pearmains" were somewhat elongated or pear-shaped. "Russets" were covered with a rough skin, and were generally sorts which hang well to the trees. "Costards" were large and bulky apples, whereas "codlins" were apples which fell to the ground when green, and were chiefly used for cooking, sauces, etc." "Cider" apples exemplified those apples—some astringent and some bitter—which were best adapted for the manufacture of cider.

So with pears. We have Beurrés, Bergamottes, cooking, and perry pears.

"Beurrés" are melting, juicy pears, which at one time were thus distinguished from hard cooking sorts. They vary widely as regards shape, period of ripening, markings, and for that reason the old classification has not been maintained, each of the Beurrés being qualified by its patronymic name. "Bergamottes" once included a fair number of pears, each being differentiated by a specific name, while "Perry" pears included those most suitable for fermenting into perry.

### SELECT APPLES (*Pyrus Malus*).

There are over 1,500 varieties of apples catalogued by nurserymen. Of these, the following, several of Australian origin, suit our requirements and climatic conditions best. Of summer apples, plant only a few. They should be worked on Northern Spy stock, preferably to any other.

On light, rich, free soil, Winter Majetin stock will do well, and on sandy soil Duchess of Oldenburg stock is recommended. All three are proof against the Woolly Aphis pest, hence



their use as stock plants. Do not plant deeply, lest the variety worked upon the Spy should throw its own roots, and become blighty and ultimately useless. The kinds recommended are named as much as possible in the order they ripen.

**IRISH PEACH, S.**—Ripens in January, good bearer, but not a keeper; does not blight. Fruit medium size, somewhat flattened and slightly angular. Pale yellowish-green, tinged with dull reddish-brown, and lively red thickly dotted with green dots on shaded side and yellow spots on sun side. Flesh greenish white, tender, crisp.

**MARJORIE HAY, E.**—A New Zealand seedling from "Irish Peach." Very early dessert apple of fine quality, blight proof. Fruit large size, conical; skin clear yellow, striped and mottled with lively red, brighter on the sunny side; flesh white, tender and crisp, juicy, aromatic flavour.

**ELLISON'S ORANGE.**—A new West Australian variety of great promise but still on trial. Introduced by Mr. A. T. Booth, Mt. Barker, and reported by our Agricultural Department as being an improvement on Cox's Orange Pippin which is much prized as a dessert apple and on the London market. It ripens earlier, a free bearer and a stronger tree.

**JONATHAN (New York), A.**—Ripens in the autumn, from first week in March, and keeps well. Tree hardy, moderately vigorous, forming an upright, spreading, round head; early and abundant bearer, young shoots rather slender, slightly pendulous, greyish brown. Fruit medium to large, roundish, conical or tapering to the eye, even and regular in its outline, eye closed, skin thin and smooth, clear light yellow ground, mostly covered with red, deepening in the sun; flesh white, very tender and juicy, rich, vinous. Succeeds wherever grown, and proves one of the best in quality and most profitable, either for table or market. Dries well. Method of pruning has already been referred to.

**BEN DAVIS** (a variety called "King David": is full of promise and is said to be earlier fit for shipment to Europe), A.—Tree very hardy and free grower, bearing early and abundantly, and blooming late in spring. The apples grow close to the limbs, which are on that account not likely to break down.

**BLACK BEN DAVIS.**—A great improvement on the Red Ben Davis, of which it is a seedling introduced from the U.S.A.

**CLEOPATRA, W.** (syn. Pomeroy, New York Pippin).—One of the best for dry districts. Keeps and carries well. Dessert or cooking. Tree grows large, upright, and bears well. Fruit ripening in April, rather large, of an oblong figure, rather irregular in its outline, and with five angles on its side, forming a kind of lip at the crown; eye closed. Skin greenish yellow, few green specks inter-

mixed with a thin grey russet, and tinged with brown on sunny side. Flesh firm, crisp, tender, juice plentiful, sweet, with a slight aromatic flavour. Does well on ironstone gravel slopes. Overbears when young, unless checked. Affected by "bitter pit" when grown on moist, badly-drained soil. Keeping the centre open and spraying with Bordeaux mixture reduces this disease.

GRANNY SMITH.—A New South Wales seedling and one of the apples which does well in almost any district. Subject to black spot in wet seasons when it should be thoroughly sprayed; also attacked by woolly aphid. One of the best keeping varieties, good for dessert, shipping or cooking. Tree: upright, vigorous. Fruit: large, roundish, conical, yellowish green, not unlike Cleopatra; few markings of russet; flesh white, firm, sub-acid, dries well. Stalk long, slender, inserted in a deep abrupt cavity; calyx closed, small, pointed, set in a shallow-furrowed basin. Hangs well. Ripens late autumn.

ROME BEAUTY, W.—Originated in Ohio. Ripens late autumn, April or May. Tree a good grower, late bloomer, productive, begins setting fruit early. It occasionally needs severe spur thinning, otherwise the fruit becomes very small. Young wood clear reddish brown, slightly downy or grey. Fruit large to very large, roundish conical, yellow, shaded and striped with red, sprinkled with light dots. Flesh yellowish, juicy, sprightly; core rather large. Fruit keeps late; gathered too soon it shrivels, is tasteless and lacks the fine colour it attains when allowed to hang on the tree and mature; windfalls may be used at once for cooking; can be landed in London in May. Subject to woolly aphid while young, the pest becoming less troublesome as the tree attains age. Fruit does not drop off readily. After bearing heavily a few years it sometimes sets and vegetates unless manured liberally. Does well on deep, heavy loam. On heavy soil it is well to keep the tree, which naturally grows upright, fairly open to permit the fruit colouring. Does well almost everywhere, especially on elevated ground.

DUNN'S SEEDLING, W. (syn. Munroe's Favourite).—First raised by Mr. Conder, of Kew, near Melbourne, who distributed scions throughout Australia. Mr. Munroe was the first to propagate it for sale. Tree upright, spreading naturally, forming a compact head. Blooms well, but sometimes fails to set, also drops after setting; thus, although an excellent bearer only carries a crop every second year. Growing vigorously, it is slow coming into bearing. This can be hastened by summer pruning and after four or five years leaving the leaders unpruned for a season and then cutting it back again the following season as the bunches of fruit borne on the tips would bend the limbs over and spoil the shape

of the tree. Dunn's Seedling is one of the best apples for export, for cooking, or for drying. Somewhat like the Stone Pippin when on the tree but of better quality when kept. Waxy yellow like the Cleopatra but firmer and crisper. Subject to cracking at the base in wet seasons and attacked by *Fusicladium*. Ripens middle of March but keeps well in store till September. In Tasmania it is two to three weeks later. Fruit roundish, conical, even surface, large, stalk medium, slender, inserted in deep cavity often russeted; calyx medium, closed set in a rather wide, slightly furrowed basin, core small, closed; flesh white, coarse, sub-acid, aromatic.

Tree not very subject to woolly aphid except when making strong and sappy growth.

**CHANDLER'S STATESMAN.**—A Victorian apple which does very well and bears regularly in Western Australia. So prolific should be planted on rich soil. The tree is a vigorous and straight grower; fruit buds well distributed along main branches or leaders; ripens late and keeps till end of the year. Fruit even size, smooth, slightly conical, yellow with red streaks on sunny side, hangs well, standing high wind without dropping. An excellent export variety.

**DELICIOUS, L.**—From Towa. Tree a strong grower, hardy and good bearer after the spurs are formed, which is encouraged by letting the leaders go unpruned for a season and shortened back again the following winter. Fruit inclined to be large, fine colour, like "Jonathan." A very fine late keeping apple. Unless picked when ripe the flavour is poor, and the texture remains woody. The fruit hangs well.

**ROKEWOOD PIPPIN, W.** (syn. Bullock's Seedling).—A hardy and fine keeping Victorian variety which does very well in Western Australia, of good keeping and carrying quality, and an abundant bearer. Sizes uneven when the tree gets old, requiring sorting. Fruit roundish, oblate, skin deep orange, heavily shaded with crimson, and dotted with brown russet. Eye somewhat open, tube conical and short, stamens medium, core ovate, axile, and solid. Flesh yellowish, firm, sugary, and juicy. Stalk short, set in a conical basin lined with russet. Inclined to overbear and stunts unless liberally fed. Spurs readily. A good carrier. Flavour improves on keeping.

**STURMER PIPPIN, W.**—An English dessert apple, ripens in winter. Tree hardy and an excellent bearer, and attains about the middle size. Fruit medium size, roundish, somewhat flattened. Skin yellowish-green, with tinge of dull red on side next the sun, and almost entirely covered with brown russet. Flesh yellow,

firm, crisp, very juicy, with a brisk and rich sugary flavour. A cool climate apple widely grown in Tasmania.

YATES, W.—Largely grown for late shipping. The tree bears its fruit in clusters, and unless thinned out these are on the small size. The thinning out is done when the apples are of the size of marbles, the centre fruit of the cluster being rolled between the thumb and forefinger when the fruit comes away leaving the stalk behind. When the stalk is torn away fruit from the cluster will probably drop. The Yate does well on rich red clay with a moist subsoil, and being a heavy bearer should be liberally fed and watered if necessary. The fruit will hang late and is picked when well coloured and when it develops a waxy feeling when handled. It is a remarkably good keeper in cool storage.

YATES IMPORTED, better known as Dougherty, is also a favourite late shipping kind. It does not require the same amount of thinning as Yate's, and is larger in size, otherwise it behaves much the same.

#### SELECT PEARS (*Pyrus communis*).

In giving a description of the choicest pears to grow, either for home use or for market, the well-known Bartlett (Williams' Bon Chretien) will be considered as the typical summer pear, and the early varieties will be those which ripen before that fruit, whilst the late ones will comprise those ripening some time after. The indifferent bearing of a great many pear trees may be attributed to blights and to defective pollination of the flowers. Recent experiments are throwing a good deal of light upon this question, and by mixing varieties and planting in adjacent rows sorts which bloom approximately at the same time, a considerable improvement has been noticed in the bearing of some pears. Pear trees should be worked on seedling pears, as suckers are troublesome. Quince stock is not always suitable. Early pears are best when gathered before they part readily from the trees and laid up for a few days. For the later kinds the season may be prolonged. Every care should be taken not to store any bird-pecked or bruised fruit; and at all times they should be delicately handled and kept in a cool, dark place.

The pear is more accommodating than the apple to soils and climate, and stands, even in the ground, an amount of salt which proves injurious to other fruit trees. The varieties are large, but mention is only made in these pages of one or two early kinds and of some which have proved to be good bearers and good carriers.

CLAPP'S FAVOURITE, S.—Tree upright, spreading, vigorous grower and heavy bearer. Fruit evenly distributed, and almost

uniform in size; ripens just before the Bartlett. Fruit medium size, obovate, slightly obtuse pyriform, surface uneven; skin thin, pale lemon yellow, faintly splashed with crimson and fawn when exposed to the sun, sprinkled with dots and russet patches. Flesh white, melting, sweet, a little perfumed. This variety blooms with Bartlett which does better when growing close to other free-blooming sorts.

BARTLETT, S. (syn. Williams' Bon Chretien).—An English pear and the most popular of all the summer varieties. Tree grows upright, with thrifty, yellowish-brown shoots, and narrow, folded leaves; early bearer and healthy, not much affected by the fusieladium; bears freely on the quince stock. Fruit large, obtuse pyriform, irregular and bossed in its outline, smooth, clear yellow, sometimes with delicate blush; stalk an inch long, stout, and inserted in shallow cavity, calyx open; flesh white, fine grained, juicy, melting, highly perfumed (musky), vinous flavour. It should be picked for export when full grown but hard, and when the pips begin to colour and the fruit stalk comes off the tree on lifting; the pear ripens on keeping; gathered before it becomes yellow, otherwise it speedily decays. Some pears blossoming approximately with the Bartlett should be planted with these trees to supply pollen to set the Bartlett crop. Amongst those are Clapp's Favourite, Howell, Duchesse d'Angoulême.

HOWELL, S.—Follows Bartlett. Tree upright and a free grower; an early and profuse bearer; fruit large, waxen yellow, sprinkled with russet dots and patches; flesh whitish, juicy, melting; a very good market pear.

GANSEL'S BERGAMOTTE, A.—A dessert pear of the highest quality. Tree rather shy bearer for the first few years, then productive, moderately vigorous, and spreading in habit. Young wood dull greyish-brown. Fruit medium to large, roundish obovate, but much flattened. Skin roughish brown, becoming yellowish-brown at maturity, tinged sometimes with a russet red cheek and sprinkled with spots of russet. Stalk short, fleshy at both ends. Cavity moderate. Calyx short and small, placed in a smooth moderate hollow. Flesh white, melting, very juicy, rich, sweet, and aromatic. When planting, intermix with others blooming concurrently.

KIEFFER'S HYBRID (American), A.—Raised from seed of the Chinese Sand Pear, accidentally crossed with Bartlett or some other kind. Fruit medium to large; oval pyriform; rich golden yellow, sprinkled thickly with small dots, often tinged with red on the sunny side. Flesh slightly coarse, juicy, melting, with a pro-

nounced quince flavour. Good for canning only. If intended for eating, let hang on the tree until almost ripe, and keep a few days in a cool dark room and its quality will be fully developed. However mature a Kieffer pear may be, it is never good when first picked from the tree. Keeps and packs well, and for that reason suitable for export. A vigorous as well as an early bearer. If allowed to become overloaded or starved, the tree produces small, hard fruit of poor flavour. Where planted on rich soil, Kieffer's Hybrid is often a bad cropper, whereas on poorer land where the vigour of the tree is checked the bearing improves. Cross fertilisation with other varieties blooming concurrently—Howell, Le Comte—is beneficial.

P. BARRY.—An American pear of the Winter Nelis class but more prolific and better in every way, and a good keeper. Gold and russet skin, large, pyriform; very juicy, buttery, excellent flavour.

PACKHAM'S TRIUMPH.—A New South Wales variety, being an improved Bartlett, coming in after that variety is over, a better keeper and good carrier; early and prolific bearer.

VICAR OF WINKFIELD, W. (syn. Napoleon).—A large, fair, and handsome French variety, also a first-rate baking pear, but sometimes too astringent; second-rate for a table pear. Tree grows thriftily, with drooping fruit branches, shoots diverging, dark olive brown, very productive, hardy; fine size fruit and a profitable market cooking pear. Fruit large and long pyriform; often one-sided, pale yellow, fair and smooth, sometimes with brownish cheek, and marked with small brown dots; stalk slender, obliquely inserted without depression; calyx large, open, set in a basin very slightly sunk; flesh greenish-yellow, juicy, with good sprightly flavour. Not much touched by *fusicladium* nor by the pear mite. Suitable for export and stewing.

L'INCONNUE (Belgium), W.—A very excellent winter pear. Tree hardy, vigorous, upright, very productive. Fruit medium or below, broad oval pyriform, light yellow, nettled and patched with russet and many russet dots; stalk long, curved, inclined and set in a slight depression, sometimes by a lip. Calyx open. Segments long and curved. Basin shallow, uneven. Flesh yellowish-white, juicy, crisp, very sweet, rich and pleasant. Packs and carries well.

WINTER NELIS (syn. Bonne de Malines), W.—Reported liable to *fusicladium*, and an irregular bearer in the coast region of California; in other localities a hardy and thrifty tree, rather slender and a poor, crooked grower, better grafted on a strong growing variety. Difficult to train by pruning alone, but by rubbing off misplaced shoots in the summer and using soft ties and

spreaders, a more shapely tree can be grown. An early and regular abundant bearer; the crop usually needs thinning, especially on trees of considerable age; fruit is always inferior when the tree is overloaded, but this applies to nearly all varieties, though not in the same degree. Fruit medium, roundish, obovate, narrowed near the stalk; yellowish-green, dotted with gray russet and a good deal covered with russet; stalk rather long, twisted, and set in a narrow cavity; calyx open in shallow basin. Flesh yellowish white, fine-grained, buttery, very melting, and full of rich, sweet, aromatic juice. Suitable for export. When planting, intermix with kinds blooming concurrently.

#### SELECT QUINCES (*Pyrus cydonia*).

Not much grown except for preserves and jellies and for giving additional flavour to cooked apples. An irregular growing tree, propagated by cuttings or by layering. The pruning consists in removing the suckers, leaving only one stem, and by cutting off irregularly placed branches. The shaping is also helped by rubbing off misplaced shoots. The tree does best on rich soil. Grows well even on salt patches moderately saline. Under favourable conditions bears profusely for a great number of years.

ANGERS, A.—This is the variety most generally used for stocks on which to bud the pear. Fruit large, yellow, keeps well. A strong growing sort, and abundant bearer.

CHAMPION, A.—Fruit very large, smooth, bright yellow; tree very productive, bearing abundantly when young; flesh cooks tender and without hard spots or cores; keeps well.

BOURGEAUT, W.—A vigorous French variety of good quality, keeps well, cooks tender. Fruit very large, golden colour, smooth velvety skin and resistant to the leaf blight.

VAN DIEMAN, W.—Seedling of "Portugal," but much more prolific and an early bearer. Fruit large and of excellent quality. One of the best.

#### SELECT LOQUATS (*Eriobotrya* or *Photinia Japonica*).

Some amount of attention has of late been given to this fruit which, coming in at a time when the market is practically bare, constitutes a kind of hyphen between the winter and the summer fruits. When the cherry does not bear it forms a substitute for that fruit. The majority of seedlings more generally grown are ornamental trees of striking beauty, the blossoms freely produced in the autumn in terminal panicles, white and fragrant, which set in compact bunches like grapes, from an inch to two inches in

diameter. The fruit ripens in the spring, contains several large seeds surrounded by juicy and refreshing sub-acid flesh ranging in colour from white to yellow. From the base of the branching spurs which carry the fruit bunches spring fresh growths which in turn will blossom and carry fruit. When these become too crowded they should be thinned out. Art and selection have of late brought forward some choicer varieties, which are rapidly becoming popular. The range of the Loquat is pretty well that of the orange. Propagated from seed, cuttings root easily. The seedlings must be grafted or budded. Does best on a moist sandy loam with clay subsoil, where they bear heavily. Deciduous; forms a dense and compact head of a rounded and symmetrical shape; requires trimming to remove crowded branches. The Loquat makes excellent jelly and for that purpose inferior fruit, even if not fully ripe, could not be better used. It takes about five years to mature a tree from seed; budded trees bear in two years.

HERD'S MAMMOTH, E.—Matures in October. Fruit large; few seeds. Dark leaves.

VICTORY, M.—Ripens beginning of October and beginning of November. Fruit large, egg-shaped; yellow-tinted amber on side exposed to the sun; flesh juicy, sugary, and pleasant in flavour. Leaves light green. Smaller than Herd's Mammoth.

GLENORIE SUPERB, a New South Wales seedling now propagated by Mr. J. Hawter, of the Blackwood Nurseries. Fruit large, round, of a deep apricot colour, mostly single stone, flesh excellent, juicy and firm.

## STONE FRUITS.

These comprise such fruit as apricots, cherries, peaches, nectarines, plums.

### SELECT APRICOTS (*Prunus Armeniaca*).

These trees are best worked on apricot root in the warmer and drier districts, as it stands drought fairly well, and is, in moister localities, apt to grow too vigorously. Plum stock stands wet better than the apricot root, has a more dwarfing tendency, and grows fine fruit, but suckers when cultivated too deeply; the union is sometimes imperfect, and it often produces gumming and the die-back diseases. Peach roots do better on lighter soil, and is generally a good stock to work apricots upon. An ideal apricot district is one which is neither too hot nor too cold, neither too dry nor too wet, but one enjoying just a happy mean. Air drainage



on sloping sheltered slopes favour the setting of the blossoms, which often drop off on trees planted in cold hollows where the air is stagnant and chilly at blossoming time. The soil should be deep and well drained: a wet subsoil is quite unsuitable. Lime is beneficial. Pruning in March, after the crop is picked, helps to strengthen the buds: the leaders, however, must not be cut back till winter pruning. Water, if possible, about that time for the same reason.

**NEWCASTLE EARLY, E.**—The earliest fair-size apricot. Ripens a week after Red Masculine, and a fortnight before Oullin's Early Peach, at the end of November on the Swan and early in December farther south. Suitable for early districts. The tree, according to Wickson, is an early, regular, and good bearer; a medium grower, being rather more upright in its habit than the Royal. Fruit full, medium size, round; rich golden yellow, with brilliant red cheek in the sun; freestone; flavour, sweet and rich; three times as large as Red Masculine, not quite as large as the Royal, nor quite as rich in flavour.

**CAMDEN PALE SUPERB** comes between Newcastle Early and Oullin's, and when Early Newcastle, now largely grown, declines in price on the local market. Ripens early in December on the Swan.

**OULLIN'S EARLY PEACH, E.**, of which there is an improved strain. This is an early form of the Peach Apricot; of large size, most delicious flavour, and ripens three weeks earlier. Like the Peach, a variety from Piedmont; about 2 inches in diameter; roundish, rather flattened, and somewhat compressed on its sides, with a well-marked suture. Skin yellow in the shade, but deep orange mottled with dark brown on sunny side. Flesh of a fine yellow saffron in colour, juicy, rich, and high flavoured. Stone can be penetrated, like Moorpark, and with a bitter kernel. Strongly resembles the Moorpark; fruit rather larger, finer, and earlier. Successful in the warmer districts. Ripens about the middle of December on the Swan, and about Christmas farther south.

**ROYAL, E.**—A fine large French variety, nearly as large as the Moorpark (when well thinned out), but with larger leaves forming on long footstalks, and without the perversive stone of that sort; quite as high flavoured, and ripens a week or ten days earlier. A favourite with the canners, and an excellent variety for drying. One of the leading Californian apricots, being a freestone, of good pale orange colour and flavour, ripening evenly. Fruit large, roundish oval, and slightly compressed; skin dull yellow, with orange cheek and a shallow suture.

A variety known as "American Royal," introduced from California, is said to excel that variety. A favourite for drying and canning. Ripens end of December.

**BLenheim, E.** (syn. Shipley).—A very good early variety, above medium, oval, orange with a deep yellow, juicy, and tolerably rich flesh; good grower, and regular prolific bearer. Fruit runs a little larger than the Royal, and is usually better distributed on the tree, but it must be well thinned. This variety is approved by canners. Ripens a little later than the Royal. Tree shy when young, but becomes productive after a few years.

**MANSFIELD SEEDLING, L.**—Fruit very large, and one of the finest grown. A good bearer and a late one.

#### SELECT PEACHES (*Prunus Persica*).

The Peach, when grown in perfection, is probably one of the best fruit cultivated. Its period of ripening ranges from early summer to late autumn. The trees are not as a rule long-lived, bearing half-dozen good crops and then decline. Under favourable conditions, however, they bear for a score of years or so. The peach in its bearing or its quality is readily affected by climate and local conditions, and one kind which flourishes in one locality may do indifferently in another in close proximity where climatic or soil conditions differ. The soil most suitable is that which yields good farm crops. On a strong loam it lasts longer than on a thin or gravelly soil; potassic fertilisers greatly benefit it.

The following are some of the favourite varieties, arranged approximately in the order of ripening:—

**FLAT CHINA, E., F.**, of which there is an improved variety, ripens earliest of all—beginning of November. Tree, a strong grower and an early and abundant bearer; for that reason not a long-lived variety. Suitable for the warmer districts of the State. Does well about Champion Bay.

**DUNHELM** (syn. Bell's November), named by the importer, Mr. A. E. Sanderson, of Guildford, from stock introduced from South America. Ripens very early—beginning of December. Crimson cheek, medium size; fruits well; similar to but smaller than Brigg's Red May. Suitable for coastal districts free from hard frost.

**BRIGG'S EARLY RED MAY** (California), E., F.—The best of early peaches. Ripens middle of November. Fruit medium to large, round; white skin with rich, red cheek; flesh greenish-white, melting, juicy, rich; stone partially free; a standard early variety; subject to mildew. In the coastal districts, west of the Darling Ranges, this variety is a disappointing one, dropping its fruit buds very extensively in certain seasons.

**ALEXANDER** (American), E., C.—A very early and excellent peach. Fruit medium to large; greenish-white, nearly covered with rich red. Flesh whitish, melting, juicy, sweet, the only fault being

its adhering slightly to the stone. Two weeks before Hale's Early. Leaves with round glands; flowers large. Its flesh is so tender it quite melts before it can be separated from the stone. Somewhat liable to curl leaf, and drops its fruit buds badly in some seasons.

HIGH'S EARLY CANADA, E., F.—Ripens with Alexander's Early before Christmas; a better bearer than Brigg's Red May.

AMSDEN, E., F.—Medium size, greenish-white, and bright red on the sunny side; stone separates freely. An American peach; remarkable for its earliness; ripening a fortnight before Hale's Early. Does well on the red soil on the banks of the Swan. Good bearer.

EARLY RIVERS, E., F.—Fruit large size; roundish; marked with a distinct suture; sometimes cracks at the stone. Skin pale lemon-yellow, with the slightest blush on one side. Flesh pale, gelatinous, translucent, with white veins through it; very tender and juicy, and with a fine brisk nectarine flavour. One of the finest early peaches. Raised from seed of Early Silver. Too luscious and tender for shipment, but invaluable for the home garden.

BRIGG'S RED MAY.—Sets well inland, but not on the coast. Early. Packs fairly well.

CARMAN.—Ripens with Early Rivers, but larger; white flesh; good heavy bearer.

HALE'S EARLY (American), E., F.—Tree very hardy; a vigorous grower and abundant bearer, but is liable to rot in some localities. Leaves with round glands; flowers large. Fruit medium, nearly round, greenish, mostly covered with red. Flesh white, melting, juicy, rich, and sweet. Fair for local market and export. Follows Early Rivers—early in January.

ELBERTA M., F. (Georgia).—A cross of Chinese Cling and Crawford Early. Fruit very large; round oval, with deep suture; golden yellow, with enough blush to make it showy. Flesh pale yellow, red at the pit; excellent flavour. It bears well and ships well; large foliage, but subject to curl leaf. Ripens just ahead of Muir, towards the middle of February.

MUIR (California), M., F.—Fruit large to very large; perfect freestone; flesh clear yellow, very dense, rich and sweet; pit small; tree a good bearer and strong grower if on rich soil, to which it is best adapted. Fruit a good shipper and canner, and peculiarly adapted to drying because of exceptional sweetness and density of flesh. Yield, 11b. dry from less than 5lbs. fresh. Ripens end of February. Does well about Mt. Barker.

PULLAR'S CLING.—A seedling from Ardmona, Victoria. The parent tree—now close on to thirty years old—still bears well. A prolific bearer of a large yellow cling-stone peach; ripens in March. A favourite with fruit canners; now extensively grown.

SALWAY (English), L., F.—Fruit large, roundish, one side enlarged, suture distinct; creamy yellow, with a marbled, rich brownish-red cheek; flesh yellow, firm, red to pit (somewhat like an apricot), juicy, rich, sweet, vinous. Of great value as a showy late peach.

SELECT NECTARINES (*Prunus Persica*, var.).

The peach and the nectarine are closely related, as shown in an illustration of a strange commixture or blending of the peach and of the nectarine on the same specimen. Although the peach is the mother of the nectarine, and this latter fruit is generally reproduced by budding, yet it has often been demonstrated that the nectarine can be reproduced from the stone without grafting or budding.

As a rule, the nectarine does not adapt itself so well as the peach to varied surrounding circumstances.

Few nectarines are worth growing, but some are excellent, amongst these:—

DR. CHISHOLM.—A New South Wales kind, and the best early nectarine, ripening just before Christmas, thus making it more valuable; good size, fine colour.

GOLDMINE, M., F.—An excellent New Zealand seedling. Fruit roundish oval, large; freestone; the pit very small. Flesh cream colour, tender, juicy, melting, and delicious flavour. Colour bright bronzy red. Ripens end of January; carries well. Tree a free and regular bearer.

VICTORIA, L., F.—Fruit very large, pale green, of good quality, and a heavy bearer. Ripens middle of February.

SELECT CHERRIES (*Prunus cerasus*).

Western Australia has failed so far to establish for cherry culture the good fame she has earned in respect to most other fruits. Were it not for the high prices offered for fresh local cherries the trees would not have proved profitable; they grow luxuriantly and blossom properly, but fail to set a crop, and birds are great lovers of them. I would caution growers in the warmer districts against planting them at all, whilst those located in the cooler and higher districts from Katanning-Kojonup to Mt. Barker, the Lower Blackwood and the karri gum country generally, should endeavour to find out which sorts suit the surrounding conditions best. A typical cherry country is a moist one possessed of well-drained slopes covered with deep soil, and one which is not exposed to very great diurnal and nocturnal changes of the temperature. In this latter respect the Western Australian climate may not prove uniform enough for cherry culture, the difference between day and night temperatures often showing variations of 30 to 40 degrees in the

early spring when the cherry blossoms are out. A climate rising at any time to 90 degrees F. whilst the cherry trees are carrying their fruit is unsuitable for cherry culture. Avoid low, black soil of valleys, and also the very dry gravelly hillsides. If there is no rainfall after the fruiting season the trees should be well watered to help maturing their buds and ensure a good setting, as the trouble in Western Australia with cherries is that although they bloom profusely they set indifferently unless soil and locality suit. Cherries are the first fruit to ripen after loquats, the season beginning early in November in Western Australia. They are followed up by apricots a few weeks afterwards.

The following are amongst the best proved in this State, according to Mr. J. Hawter, of the Blackwood Nurseries:—

**BIGARREAU NAPOLEON, M.** (syn. Spotted Bigarreau).—A magnificent cherry of the largest size, beautiful appearance, and rich flavour. Tree a vigorous grower, very hardy, and not subject to gum; a free bearer. Fruit pale yellow, becoming amber in the shade, richly dotted, and spotted with deep red, and with a bright red cheek; flesh very firm, juicy, and sweet; a good carrier.

**BING.**—An American cherry much prized; fruit large, dark brown or black; late.

**BLACK BOHEMIAN OR TARTARIAN.**—Large, heart-shaped; skin glossy, purplish black; very good black cherry; medium.

**BLACK EAGLE, E.**—Medium size; deep purple or nearly black; flesh deep purple, tender, juicy; ripens middle of November.

**BURGDORF'S SEEDLING.** Raised at Harcourt, Victoria. A first class large, early, dark cherry; good bearer. The best early cherry here.

**ST. MARGARET, L.**—Very late. One of the best late marketing cherries grown; stands carrying well. Fruit very large, obtuse, heart-shaped, uneven on its surface, and considerably flattened next to the stalk on the side marked with the suture. Ripening with Florence; the best at Cherrydale, Donnybrook. Skin at first dark red, changing to dark blackish purple. Flesh dark purple, adhering firmly to the stone, firm, sweet, and briskly sub-acid.

**SUDA.**—A good late cherry; tree hardy, thrifty grower, and exceedingly prolific; of Morello class; bears freely everywhere, but small; good for culinary purposes.

**WERDER'S EARLY BLACK.**—A fine black cherry, of good flavour; great and early bearer.

#### SELECT PLUMS AND PRUNES (*Prunus, sp.*).

E., M., L., denote early, medium, late respectively; K cooking; D, dessert fruit.

The distinction as plums and prunes of species of the same genus of plants is somewhat recent. They used to be called plums by English-speaking people, just as in France they are all known as prunes. In France, however, the fruit when dried and cured are known as *pruneau*, and it is thus that in America and other countries the word prune is specifically given to those plums which will cure into a firm, meaty, dried fruit, from which the seed is not removed.

In the descriptions of suitable varieties given below, prominence has been given to those which are dried into prunes, as they also happen to constitute excellent dessert fruit, and being meaty, sweet, and firm, they pack and carry well.

Such varieties as the Robe de Sergent, Fellenberg, or Italian Prune, having been left out, as they are shy and disappointing bearers, although they are of excellent quality. In California they are now being as rapidly replaced by more profitable sorts as they were extensively planted a few years ago.

Plums have been classified into different families such as:—

- 1st. *Prunus domestica*, native of Asia, and the parent of European varieties such as damson, greengages, and varieties commercially known as prunes.
- 2nd. *Prunus cerasifera*, of which the myrobolan or cherry plum is the type. These are natives of South-Eastern Europe and South-Western Asia, and are used mostly for stocks; they are the parents of Mariana and other varieties, which are either offshoots of this species or hybrids. Red and yellow fruit; also *P. pissardii*, with claret-coloured leaves.
- 3rd. *Prunus triflora*, or the Japanese type.
- 4th. *Prunus simoni*, or the apricot plum, a native of China.

Prunes have been disappointing in many parts of Western Australia, where, although they bloom well, fruit badly. They are better at home in the cooler and moister districts of the South-West, and even there they do better when irrigated in the summer months to strengthen their buds. Like shy-bearing apricots, they should be systematically summer pruned by cutting off portion of the laterals, and now and again leaving the leaders unpruned for one season, but cutting them back the following year. Pollination may also be defective, and planting different varieties in alternating rows is recommended. Potash and bonedust by nourishing the buds, favour fruitfulness.

DAMSON, E.—Cultivated for cooking purposes. There are several varieties of this fruit all originating from the native English plum. Amongst the best is Crittenden's Cluster, or Prolific. Fruit larger than any of the others, roundish oval, skin black, and covered with a thin bloom. Tree a heavy bearer. Young shoots downy.

PRUNE D'AGEN, Fig. 1  
 (syn. French Prune, Prune d'Ente), L.—Ripens late in the season, end of March. In dry places very liable to shed its leaves and drop its fruit. The most propagated in the Valley of the Lot in France and also in California. Tree of moderate growth. Young shoots dense, smooth. Very productive. Fruit medium size, oval, slightly necked, suture small. Skin violet purple, covered with a thick bloom and numerous small dots. Stalk nearly an inch long, a little curved, set in a small depression. Flesh greenish-yellow, juicy, sugary, rich and delicious, slightly adherent to the stone. The best of all prunes. When cured contains 35 to 50 per cent. sugar. When fresh 15 to 30 go to the pound, and 45 to 75 to the pound cured, with a ratio between cured and fresh fruit of 1 to 2.55 to 2.90.

SPLENDOR (Fig. 2).—A cross between the Prune d'Agen, fertilised by Pond, or Hungarian Plum. Tree vigorous, upright, and uniform in growth; not so thick as the Prune d'Agen, which it resembles. Fruit free-stone, ripens two weeks earlier than its parent, and much larger. Flesh yellow, stone long and narrow, drying dark, does not shake from the tree. Earlier than French prune by two weeks. It is a clear, even red, and

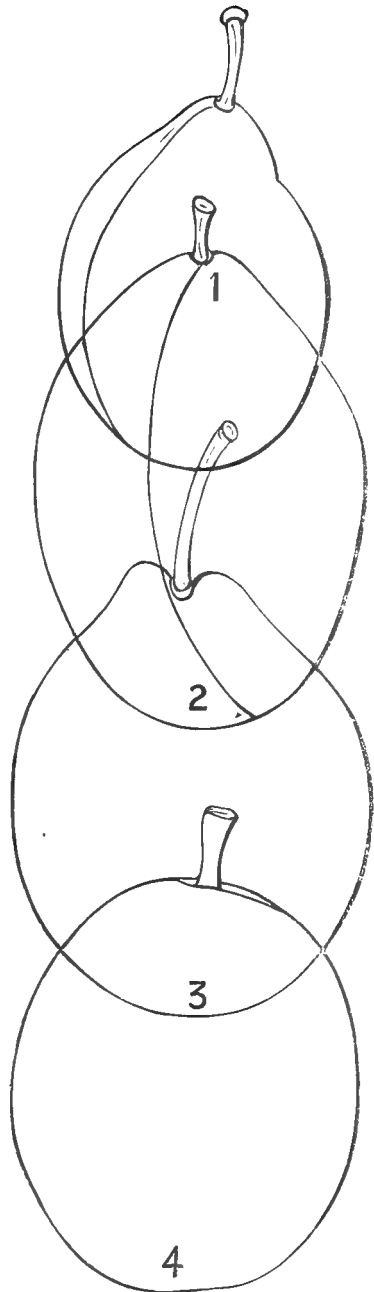

turns quite black in curing. Highly spoken of for drying, shipping, market, and as a dessert fruit. The following comparison between the Splendor and the Prune d'Agen is by Mr. G. Colley, of the Cal. Univ. Exp. Station:—

	Splendor.	French.
Number per lb. . . . .	15.75	19.20
Flesh, per cent. . . . .	95.70	94.20
Pits, per cent. . . . .	4.30	5.80
Juice, per cent. . . . .	88.0	83.1
Pulp, per cent. . . . .	12.0	16.9
Sugar, per cent. in juice . . . . .	22.87	23.69
Sugar, per cent. in flesh . . . . .	20.13	19.70
Sugar, per cent. whole fruit . . . . .	19.27	18.50

This shows that the fruit is closely comparable with the French prune. The Splendor is greater in juice, and would probably lose more in drying. The exact drying value of the prune must be determined in practice. The acid in both prunes is identical, and from this fact, and what is given above, the two fruits belong to the same class in richness and flavour.

**SILVER PRUNE.**—Mr. J. Hawter, of the Blackwood Nurseries, says that he can endorse the American description that one tree of Silver Prune produces more fruit than five of Coe's Golden Drop (its parent) which it most resembles, and dries with very little loss of weight, retaining its light yellow colour; clingstone; a fine market Plum.

**DIAMOND.**—A very large, fine dark Plum, good bearer, very good for preserving, best market. Ripens end of January.

**MAGNUM BONUM, YELLOW** (syn. Egg Plum, English), L., K.—Popular on account of its large and splendid appearance, and a slight acidity, which renders it admirably fitted for making showy sweetmeats or preserves, good cooking, poor dessert. When raised in a fine warm situation, and is fully matured, it is pretty well flavoured, otherwise it is coarse; a spreading grower, branches smooth, long, a pretty good bearer, though apt, in light soils, to drop from the tree before becoming matured. Fruit very large, oval, narrow at ends, necked at base, suture distinct; stalk one inch, not sunk, surrounded by fleshy ring at insertion; light yellow, bloom thin, white; flesh firm, rather acid until fully ripe, and then sweet, adheres to the pointed stone. Ripens in February.

**POND'S SEEDLING** (syn. Hungarian Prune), Fig. 3, L., K.—Late English sort. Tree very vigorous and productive; a beautiful red, large, ovate fruit, slightly tapering to the stalk. Skin thick, reddish violet, with numerous brown dots, and covered with a thick bloom. Flesh coarse, adhering to the stone. Branches smooth, grayish. Sells well on appearance. Ripens with its middle to end of February; is suitable for jam or canning.



## JAPANESE PLUMS.

( *Prunus triflora*.)

The names so commonly applied to Japanese plums as Botan, Satsuma, Hattankio, etc., really refer to districts or to classes, thus: Satsuma originates from the island of that name; Hattankio is called after "hatan," an almond, which this large oval-pointed plum resembles. Many hybrids have been raised and named in California; none of these plums make a large tree on their own stocks; they grow larger on peach. The best of these, in the order they ripen, are:

SHIRO SMOMO (syn. Red June), E., Fig. 1. —Ripens first. Tree of spreading habit, foliage dull, fruit deep crimson all over while still firm; shaped much like a small Kelsey, that is, with very marked and lengthened apex. Size  $1\frac{3}{4}$  inches. Cling. Flesh yellow, juicy, moderately firm, good for market. A sure cropper.

BOTAN OR ABUNDANCE, E.—Glossy foliage and inclined to grow upright. Fruit roundish with very little point and gets dull red on one side.

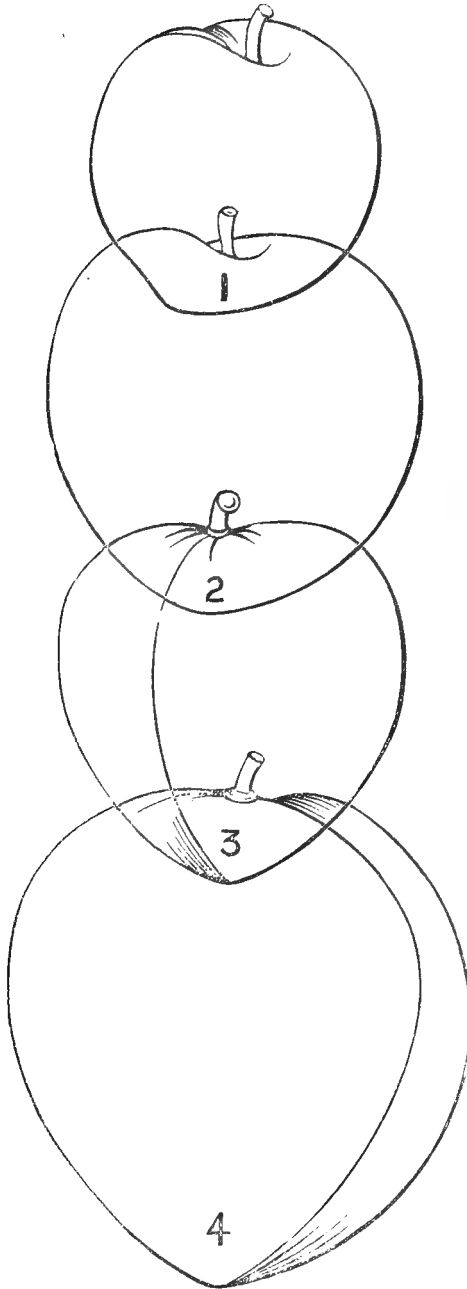

Ripens a week after Red June is gone, and gets soft very soon after ripe. A strong grower.

BURBANK, E., Fig. 2.—So called after its introducer. Tree, imported from Japan, vigorous, with strong upright shoots, and large, rather broad leaves; comes into bearing very early. Fruit almost globular, large rich cherry red, slightly mottled with yellow, and freely dotted with same tint. Flesh, deep yellow, juicy, very sweet, and of fine, somewhat peculiar but agreeable flavour; pit very small, clingstone. Very productive. Ripens beginning of March; should be picked while still firm and ripened indoors like a Bartlett pear; it will colour well and become juicy. Good for home or distant market.

WICKSON, L., Fig. 3.—A cross between Burbank and Kelsey. A valuable market plum, its time of ripening being late when the glut of peaches and other plums is over. Shape somewhat similar to Kelsey, but more symmetrical. Colour cherry red to claret. Flesh amber, pit small. Is picked before it colours up, and on keeping develops an intense carmine. Tree a shy bearer in its younger days. Rather given to scalding in the warmer districts, but very profitable in cooler localities. The fruit needs thinning out to secure good size, and with a slight bloom, peels easily when ripe; good for cooking, fair for dessert.

KELSEY (syn. Hattankio), L., Fig. 4.—Tree upright in growth, having a tendency to long slender branches, which should be frequently pinched back; leaves narrow, twigs brownish grey. Very productive and apt to break down. Fruit large, from  $1\frac{1}{2}$  to  $2\frac{1}{2}$  inches diameter, heart-shaped, with a distinct suture on one side from stem to apex; stem is short and set in a depression at the large end; colour, mixed yellow and purple, which vary in depth, but rarely make a brilliant appearance, covered with a bloom; flesh yellow, very firm, and clings to the stone, which is rather small, and nearly always partly surrounded by a cavity; when fully ripe the quality is very good. In California the tree resists drought remarkably; it is almost an evergreen, liable to injury in severe climates; comes into bearing as young as the peach; requiring same pruning, ripens late. Likes heavy, moist land; when planted in proximity with other sorts, such as Satsuma, the blossoms set better. Ripens end of March. Likely to prove a profitable market and shipping variety.

SHIRO.—One of the Burbanks. Ripens in the Blackwood middle of December when dessert fruit is comparatively scarce. May be gathered weeks before it is ripe. Yellow transparent colour. Good size, round, clingstone, one of the best.

SATSUMA BLOOD (syn. Yone-momo), L.—Leaves more lanceolate than those of Kelsey; fruit averages about  $2\frac{1}{4}$  inches in diameter, nearly round, and but slightly sutured on one side; colour

dark red under a thick bloom; dots rather conspicuous and numerous; flesh dark purplish red (blood colour), firm, stone very small and pointed. Ripens earlier than the Kelsey. Keeps well, and will not spoil for weeks after it is ripe; can be left hanging on the tree for three or four weeks after it gets deep red.

#### CITRUS FRUITS.

Supposed to have been brought from China to India and thence, step by step, to Europe and later, to America. Tree tender to frost. Should never be set deeper than they were in the nursery, and on damp, low-lying soils a few inches higher. On deep alluvial soil, moist and fertile, it thrives best although lemons are more accommodating in this respect; avoid swampy sodden soil and shal-

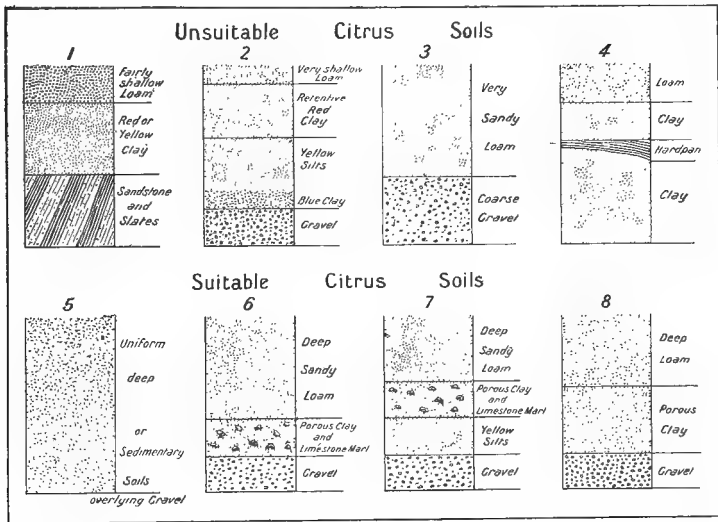

low dry soil. For heavy crops and quality, water is essential, but this must be running water or irrigation on well-drained soil. Propagated by seed, layers, cuttings; the seedlings are generally budded. Such heavy fruiting trees require liberal manuring, and a combination of concentrated chemical fertilisers is needed to restore and maintain the fertility of planted orchards. Excess of potash thickens and toughens the rind, and reduces the saccharine qualities. Phosphoric acid, on the other hand, favours the formation of sugar and modifies the acid contents while highly nitrogenous application favours rank growth and abundance of insipid juice. A combination of the three gives the best results. In a dry climate the cultivation must be frequent and, except when the roots strike deeply, it must be fairly shallow but thorough in order to maintain a dust mulch and prevent loss of moisture.

The climate must be warm, free from hard frosts and sufficiently moist unless irrigation can be practised.

Numerous species belong to the citrus family, but of these four or five only have for us a commercial value, viz., the Orange, the Mandarine, the Pomelo, the Lemon, and the Kumquat.

#### ORANGE (*Citrus aurantium*).

The most notable of these are arranged in the order in which they ripen. The sorts we favour are smooth, thin-skinned, tender, juicy fruit, that will sink in water, preferably the seedless varieties. They are known as "sweet" oranges in contradistinction to "sour" oranges of which the Seville is the type.

The orange stands frost better than the lemon, and does not succumb to a temperature of  $-3^{\circ}$  or  $4^{\circ}$  C. ( $20^{\circ}$  to  $25^{\circ}$  F. of frost) if these low temperatures are not lengthy, and when the thawing is gradual. It requires a mean summer temperature of  $22^{\circ}$  or  $23^{\circ}$  C. ( $71^{\circ}$  to  $74^{\circ}$  F.) to ripen.

THE NAVAL (syn. Bahia) stands prominently to the forefront amongst our choicest oranges. Imported from Bahia, Brazil, into the United States, it has been distributed to every part of the world offering suitable climatic conditions to its successful cultivation. The blossoms of navel oranges are double, having a secondary blossom within and no pollen. When an occasional seed is found in them it is the result of transported pollen. With us the Navel Oranges do well from the Gascoyne River in the North to the Harvey in the South. The ripening season ranges from April to August, and they can thus be landed in the European market where the variety is little known in the summer when the demand is the greatest.

Few citrus varieties sport more readily than does the Navel, and we have now in cultivation a number of these oranges, which differ materially from one another as regards appearance and time of ripening. Amongst the most noted are:—

AUSTRALIAN NAVAL.—The foliage resembles that of the Washington Navel. The fruit varies in size, all sizes generally being found on the same tree. A very shy bearer. Blooms profusely, but very few of the blossoms set; often the trees are loaded with fruit, and after having attained the size of marbles drop to the ground, without any apparent cause; fruit also has a tendency to split at the navel, which is usually large and prominent, unlike that of the Washington Navel, which is round and generally small. Seedless. Flavour as good if not superior to that of the Washington Navel. The tree is a strong grower.

WASHINGTON NAVAL.—The variety was, like all Navels, introduced from Bahia, Brazil, into the United States, whence they found their way to every part of the globe where climatic con-

ditions are suitable to orange culture. No market has ever yet been glutted with well-grown oranges of this sort. The tree, although hardy and vigorous, is of medium size, with dark-coloured leaves and is armed with a few small thorns. A rapid grower, and an early and abundant yearly bearer; requires a free, deep, well-drained loam, and does not thrive on poor, sour, and badly-drained land. Fruit, large, solid, and heavy; skin, smooth and of very fine texture; very juicy, high flavour; is generally seedless. Apart from the valuable qualities enumerated, this variety is one of the earliest and best tested of all the Navel oranges; it is a good keeper, and well suited for export.

The season in California for the Washington Navel is from January to July, while in Florida it extends from November to February, but in Florida, as well as in Cuba, and in the West Indies, its cultivation has never been a success, and it has been supplanted by other kinds and by the grape fruit—a variety of Pomelo. The dry summers and wet winters, as in the case of California and in the South-West of Western Australia, retard the maturing of citrus fruit. Not so in Florida, where the summer rains, like that of India and of the Northern coast of Australia, and the dry winters, hasten the maturation.

**JAFFA.**—Mid season. Large, oval fruit; skin coarse; pulp rich and juicy, almost seedless. Tree strong grower, with very large leaves curved and wrinkled on the strong young shoots; thornless. In Jaffa rainless summer accompanied by heavy night dews, and winter without frost, are well suited to the growth and development of the trees, which are watered in the summer and plentifully manured.

**VALENCIA, LATE.**—Tree a strong grower, does not begin to bear as soon as most other budded sorts; few thorns, dark foliage; fruit medium size, roundish oval, tapering towards the stem, skin smooth; pulp acid till fully ripe, few seeds, solid, of good quality. The fruit ripens in the early spring, and will hang a long time. Commercially, it is placed next to the Navel. The tree is inclined to produce a good crop only bi-annually. A strain known as “Hart’s Tardiff” in California, has been widely propagated. Does well in Florida, and should also do well in Northern Australia.

**THE SEVILLE** (syn. Sour or Bitter Orange), *C. Bigarradia* or *Vulgaris*, said to have been brought from the East by the Moors, who established large plantations of it about Seville, in Spain, hence the name. The hardiest of all varieties, enduring very hard frosts without injury. It has the largest and most fragrant flowers; the pulp, however, is bitter and acid, and is valued chiefly for marmalade. Several types are grown, which raised from seeds have somewhat varied, viz., the Round, the Flat, and the Sweet Seville; fruit fairly large, about three inches in diameter, and flattened at both

ends; skin rough and thick, dark orange, and bitter; when boiled becomes transparent. The pulp, when cooked with sugar, sets to a jelly. Tree a strong grower, with large, shiny, bright green leaves, long and pointed, with well-developed wings, thorny. Thrives on heavier soil better than do sweet oranges.

QUEEN.—An Australian variety, thriving well in the drier localities. Fruit medium size to large, somewhat ovate, regular in shape and size; skin thin, smooth, rather light in colour; often a ring at the calyx end; flesh juicy and of good flavour.

SEEDLINGS.—Numerous seedlings exist, some of which exhibit features which are worth propagating, but they often fail in some of the standards required from a profitable commercial orange. One of the best of these West Australian seedlings is the

CHERITON (syn. Gingin).—A West Australian seedling, grown from seeds about 50 years ago by Mr. H. Brockman, in his orchard at "Cheriton," on the Gingin Brook, some fifty miles north of Perth. Tree a very strong grower, erect, thorny, with good foliage. Fruit large, roundish, and a little tapering towards the apex. Thirty oranges picked from different gardens gave an average weight of 11oz. to 12oz., while a few weighed over 1lb. each. Skin medium thin on fruit on the top of the tree to thin on fruits on older bearing branches at the base; peels off easily. Fleshly, few seeds, solid, juicy, segments parting easily after peeling, sweet, hangs well. Ripens from July to end of September.

#### MANDARINS (*Citrus nobilis*).

Much grown in India. The leaves and blossoms are smaller than those of the orange. Branches slender; fruit flattened, with segments loosely adhering, forming a hole in the centre; rind yellow, glossy, easily detached. Fruit very juicy and sweet when ripe. Tree medium size, and almost thornless.

SCARLET MANDARIN.—Very profitable on account of its earliness in bearing and in maturing its crop. Tree upright, spreading, vigorous grower, above medium size, almost thornless; fruit large, flattened at both ends. Before ripening the rind is moderately tight, but as the fruit ripens becomes puffy and assumes a reddish orange colour; it is easily detached from the pulp. When fully ripe the segments surround a hollow core. Pulp dark orange, sweet, of fine flavour. Grows best in a semi-tropical climate. A bad carrier, and requires careful picking and sweating before shipping.

THORNY MANDARIN or TANGERINE.—One of the best flavoured of all mandarins. Tree a dense bush requiring severe thinning out to bear large fruit; thorny, except some sub-varieties which are thornless. Fruit small to large, according to number of fruit, vigour of trees, and soil and climate; roundish, flattened; stem fine and

firmly attached to fruit; skin tight, thin, and smooth, pale yellow. Pulp juicy and aromatic. This fruit becomes dry and puffy if allowed to hang too long.

EMPEROR MANDARIN (syn. Canton).—Tree large, upright, strong, and good bearer; few thorns, leaf large; a heavy bearer. Fruit not so handsome as the Scarlet, and varies somewhat in type; medium size to large, roundish, irregular, and flattened at the eye. Skin yellow, brittle, tearing easily, and somewhat puffy when the fruit is over-ripe. Called in China the Mandarin or Noble Orange.

BEAUTY OF GLEN RETREAT.—Origin obscure, although the parent tree from which all the trees of that variety are derived grows in the orchard of Mr. W. H. Parker of Glen Retreat, near Brisbane. Tree of large size, vigorous, forming a dense head unless kept pruned, thornless, possessing a distinct foliage. Bears early and abundantly; fruit large, solid; skin thin, smooth, tough, and tightly attached to the pulp, which contains practically no rag. Pulp, firm, juicy, sweet; few seeds. Fruit a good carrier.

#### KUMQUAT (*Citrus Japonica*).

Is very hardy and prolific and bushy. A native of Japan, where it is known as "Kin-Kan," which means "gold orange," "Kumquat" being Chinese for the same name. Being dwarf it can be planted close, *i.e.*, 12ft. apart. Two varieties are grown—a round and an oval-shaped fruit; small, about the size of a large gooseberry; rind sweet and smooth, yellow, thick; high scented; pulp acid; many seeds. When quartered and boiled with sugar makes excellent preserves; steeped in spirits constitute very good bitters; crystallised it makes very good confection. The Chinese export considerable quantities put up in small stone jars. They also eat the fruit without peeling the rind. Apart from its economic value, the Kumquat is well worth cultivation in gardens for its ornamental appearance. The tree has slender branches without thorns, small leaves, and bears freely.

#### THE POMELO (*Citrus decumana*).

Also called "Shaddock" after a sea captain of that name, and in the United States of America "grape fruit," on account of the tendency of the tree to carry its fruit in bunches. The Dutch, who first procured it from Ceylon, introduced it into Mauritius under the name of Pampelmous, a corruption of the Indian name for fruit. The name Pomelo is generally given to the bigger kind, and the American term "grape fruit" to the clustered and smaller fruit. Of these the Florida kinds are better liked than the Californian. The fruit is borne in bunches—"Grappes"—at the end of the shoots. The young growths and flower buds are coated with silvery hairs. Trees vigorous and resistant. Several varieties are grown, weighing

from 1lb. to 12lbs. each. Some of the smaller varieties, with a fairly thin rind and oblong, which are imported from Singapore, are the best. The larger sorts with a thick, spongy rind are much esteemed for making into preserves and for candying. The pulp is regarded as very wholesome and refreshing, and possessing valuable tonic properties. Large quantities are exported from Jamaica to the United States, and its cultivation is regarded as quite as profitable as that of the orange.

TRIUMPH.—Slightly flattened at the base and apex. Size  $3\frac{1}{2}$  in. x 4 in.; light yellow, smooth rind, not so bitter as other sorts, fairly sweet, juicy.

MARSH'S.—Seedless, oblate roundish, 3 in. x  $4\frac{1}{2}$  in., light yellow, sections thirteen; flesh greyish green; bitterness not strongly marked; acidity and sweetness medium; seeds absent, or very few.

The Pomelo or Grape Fruit should be allowed to get thoroughly ripe on the tree to attain its full flavour. The tree when budded, either in the sour orange or the rough lemon stock, is a vigorous grower, and very prolific. This fruit does particularly well in Florida, which has a climate much like that of our tropical provinces of Kimberley, where I have seen very fine pomeloes growing. Thousands of acres of grape fruit are cultivated in Jamaica, Porto Rico, Cuba, California, and Florida. In the latter State the area under this fruit is greater than the total area of all sort of citrus fruits in Australia. The fruit always meets a ready market all through America. In Queensland the returns from the few grape-fruit trees is said to vary from £2 to £6 per tree. The fruit carries and keeps well.

*Directions for Eating Grape Fruit.*—Do not peel; with a sharp knife cut transversely; cut out the seed centres; cut round the pulp next the skin, loosening and dividing neatly; sugar; leave in these natural (slightly bitter) cups for several hours; eat it thence with a spoon. The taste, a wonderful blend of slight bitterness, acidity and sweetness, is very pleasant. The fruit has great digestive and tonic virtues.

#### THE LEMON (*C. limonum*).

Does not withstand low temperatures as well as the Pomelo, Mandarin, and the Sweet Orange. A temperature of  $-2^{\circ}$  C. ( $28.5^{\circ}$  F. of frost), if at all prolonged and if the thawing is rapid, will hurt it; whereas oranges will withstand  $-3^{\circ}$  C. ( $26.5^{\circ}$  F.) The lemon will stand more prolonged drought than the orange. The autumn-picked lemons cure and keep best, and may be stored until the spring.

VILLA FRANCA, Europe (Fig. 1).—A summer-bearing lemon, sets to fruit early. Tree almost thornless, branches spreading and somewhat drooping, leaves long and pointed; foliage abundant to



protect the fruit from the sun; said to withstand a lower temperature than other varieties. Fruit of medium size; considered to be one of the finest of lemons grown. Fruit oblong, slightly pointed at the blossom end, rind thin, without any trace of bitterness even when green; acid strong, juicy; nearly seedless. Keeps and ships well.

**EUREKA (California).—**Fruit medium in size, oval, and more oblong than the Lisbon, sweet rind, a very good keeper and very popular. Skin bright yellow, thin and smooth; very juicy and briskly acid; hardy and prolific. The drawback it has is that the leaves are inclined to curl, scarce foliage, fruit produced at extremities of branches, and liable to get sunburnt; but this is generally avoided by letting the branches hang low, and prune as little as possible. Tree almost thornless.

**LISBON (Portugal, Fig. 2).—**Tree a strong grower, bears fruit all through the tree, not very early in coming into bearing; prolific bearer, and makes a larger tree than other varieties, for this reason the trees of this variety should be planted a good distance apart and not less than 24ft. from one another; quite thorny, but thorns decrease in size as the tree grows older. Fruit uniformly medium size,

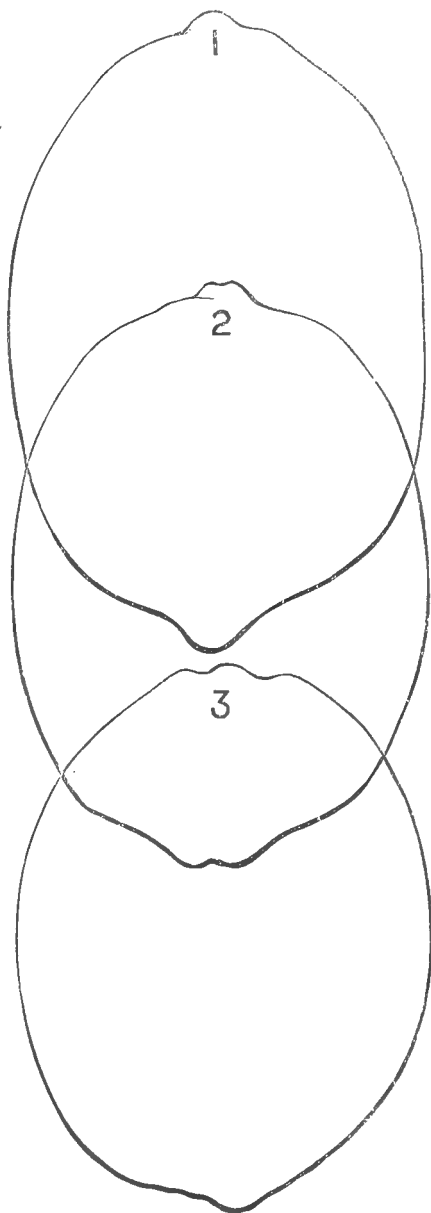

fine grain, sweet rind, very juicy and briskly acid; very few seeds; a good keeper; can be picked at any time of the year. There are several sub-varieties of the Lisbon, such as the "thornless" and the "variegated," differing from the parent to the extent their names imply. When allowed to ripen on the tree the rind thickens, and the fruit is coarser.

SICILIAN (Fig. 3).—Rounder than the Lisbon, which it otherwise resembles. Tree almost thornless and prolific; an early bearer, and a good market lemon.

#### THE LIME (*C. limetta*).

The most tender of the citrus tribe, as it is always growing. Does not stand frost and is best suited to the the tropics. Grown from seed which generally comes up true to kind, seeds from the best fruits being selected; is also budded. The stock succeeds well on dry soil or even on rocky soil or those underlaid with rock. Around Port Darwin I have seen lime trees growing unattacked by the ubiquitous white ant which destroys other citrus trees. The tree is of shrubby growth, can be planted closer than other citrus trees, very thorny, except a few varieties; exceedingly robust and requires little attention. The fruit varies in size from a small egg to a good size lemon; pale yellow, pulp light green and filled to bursting point with a very sharp acid juice, used in preference to the lemon in the tropics; a bad carrier. Early and very prolific bearer. Used in the manufacture of citric acid and of lime juice and for seasoning food and providing cool drinks.

Of varieties:—

WEST INDIAN.—Small and very good; much prized for lime-juice.

TAHITI grows as a round-topped shrub. Fruit broadly oval—3in. x 2.5in., lemon yellow, smooth thin rind, flesh fine-grained, juice plentiful, almost colourless, very acid and pleasant flavour, few or no seeds.

#### FIGS (*Ficus carica*).

The fig like the grape vine thrives in Western Australia where other fruit trees sometimes fail to be productive. In the cooler districts sometimes fails to mature its fruit, and is better suited for the warmer localities. Moist, sandy loams are also more congenial to the fig tree than are heavy clays. The fig itself, which is generally spoken of as a fruit consisting of a mass of pulp enclosed in a thin skin, is to the botanist an inflorescence, in which the outer covering is a receptacle for the hundreds of microscopic flowers inside. The tree attains large dimensions and is long-lived and when many are planted together, they should be set wide

apart, viz., at least 40 feet or more, the space between utilised for some years and, until the figs have attained a large development, with Japanese Plums, Peaches, Loquats, Passion Vines, etc., which can be grubbed out after they have outlived their period of utility. Fig trees are very useful for the shelter they afford and for their fruit, in pig paddocks; the trunks, however, should then be protected as they would be sure to be damaged by the pigs. For all practical purposes, edible figs may be considered under three classes: (1) the Wild or Capri; (2), The Self-sterile or Smyrna type; (3), The Self-fertile or Adriatic type.

THE WILD OR CAPRI.—The only value of this class of fig is to serve as host for the minute wasp (*Blastophaga grossorum*) which enters the self-sterile or Smyrna type of figs and fertilises them. In fact, it has been said that the Capri fig and the Smyrna fig stand in the relations of male and female to each other. They both, however, possess male and female flowers, but these ripen at different times and therefore need external interference for their fertilisation.

This is provided by the minute wasp above referred to, and which acts in this way: The fruit of the Capri fig, which as a fruit is worthless, is like all figs really a hollow inflorescence. It produces three crops annually. The *profichis* first of all; the *mammoni*, which buds out when the *profichis* are ripe and the third crop or *second mammoni*, which makes its appearance as the first *mammoni* ripens.

These inflorescences are possessed of male and female flowers, both with a predominance of male or staminate flowers in the *profichis*. On this account this crop is of more particular value to the Smyrna or self-sterile class. The succeeding second and third crops or *mammonis* serve only as a habitat for the fig wasps and enable them to tide over the seasons.

The propagation of the fig wasp proceeds as follows:—The female *Blastophaga* wasp forces its way through the *ostolium* or eye into the fig and having done so lays one egg in each of a number of the ovaries of the female flowers and dies within the fig. In consequence of this puncture the ovary swells and forms a gall with a wasp embryo inside instead of its own embryo. From the eggs that are laid some produce wingless male and some winged female wasps, the first issuing first; these then gnaw their way into the gall ovaries in which the females lie, impregnate them, and die. The fertilised winged females then gnaw wider the passage made by the males, and either enter the following crop of Capri figs or *mammonis*, or if Smyrna fig trees are close by they penetrate the eye of these figs then in proper state of development. In issuing from the Capri fig they brush past the staminate or male flowers which surround the eye, and issue out of the fig dusted with fig pollen.

This pollen, in their endeavours to lay eggs on the ovaries of the figs they penetrate, they scatter about and thus fertilise the female flowers. Should they have entered a Capri fig or *mammoni*, they puncture the ovaries and propagate their kind, whereas should fate have taken them to a Smyrna fig they die, leaving no offspring.

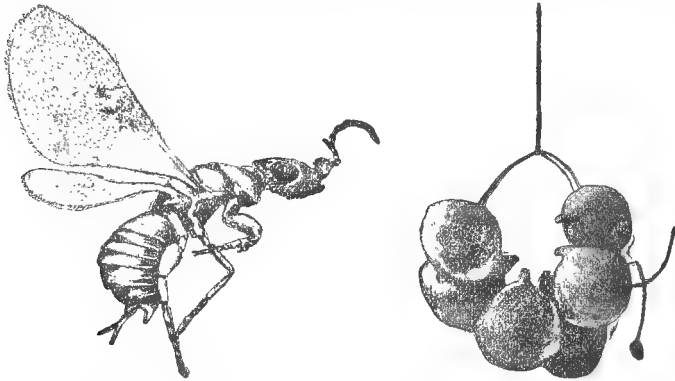

Blastophaga Wasp (greatly enlarged). String of wild capri figs carrying the fertilising insect (reduced size.)

In Smyrna fig plantations it is therefore important to also plant a few Capri figs or graft branches here and there with this kind, or to adopt the practice prevailing in the South of Europe and in Algeria, which consists in attaching the Capri figs to strings and hanging a few in each tree.

Mr. J. Hawter, of the Blackwood Nurseries, secured some years ago the stock of Capri and of Smyrna figs introduced from California by the Department of Agriculture, and has since propagated them together with other kinds also capable of carrying the fertilising wasp. These were twice introduced from California and from Natal by the Department of Agriculture, but they will not be permanently established until the Capri and the Smyrna figs can be more widely planted. The State entomologist, Mr. Newman, has, however, located the fertilising wasp in figs grown in the vicinity of Fremantle, where they appear to have established themselves.

THE SMYRNA CLASS embrace all those figs which are not self fertile and require external agency for the successful production of their crop.

Several varieties of figs are dried and exported from Smyrna. Most of them need the wild fig pollen and the agency of the *Blastophaga grossorum* wasp.

Fruit large, turbinate-pyriform, flattened; short neck, ribs distinct, orifice large, skin lemon yellow, pulp reddish amber, very sweet. Dries readily.

The Smyrna Fig of commerce proper stands out amongst them, almost as prominently as does the Washington Navel amongst Oranges.

Two distinct crops come out in the season—the first coming out in the Spring out of the previous year's shoots; and the second growing on the new wood just as the former is ripening.

Only a few of the first crop mature, the bulk of them dropping from the tree when quite small. Like all immature first crop figs, these, although of large size, contain nothing but hollow seeds and lack flavour and substance. The ostiolum or eye is closed, and fertilisation cannot take place.

The ADRIATIC or self-fertile class comprise all those figs which need no external assistance to mature their fruit.

Most of them bear two crops, and some drop their first crop. Only white, cream, and pink fleshed figs are dried; black-skinned have no commercial value for drying. Three to four pounds of green fruit yield one pound of dried.

STUBBERFIELD'S EXTRA EARLY.—A new kind of value for ripening very early.

WHITE GENOA. (syn. White Marseilles, White Naples).—One of the most delicious figs in cultivation. Good for table, peels off easily, and dries remarkably well. Fruit: above medium, quite round, with a short neck and well-marked longitudinal ridges running from the stalk to the apex. Skin pale green. Eye open. Flesh opaline, exceedingly rich, juicy, and sugary.

WHITE ADRIATIC (syn. Fico di Fragola or Strawberry Fig).—One of the finest grown, and a strong growing and hardy kind. Fruit: medium size, rounded pyriform, with medium neck. Skin greenish in the shade, greenish-yellow in the sun. Eye open, with red iris; pulp bright strawberry red, drying to a rather pale yellow. Skin very thin, and together with the pulp forming a most delicious sweetmeat when grown in favourable places. The first crop does not set but the second is abundant.

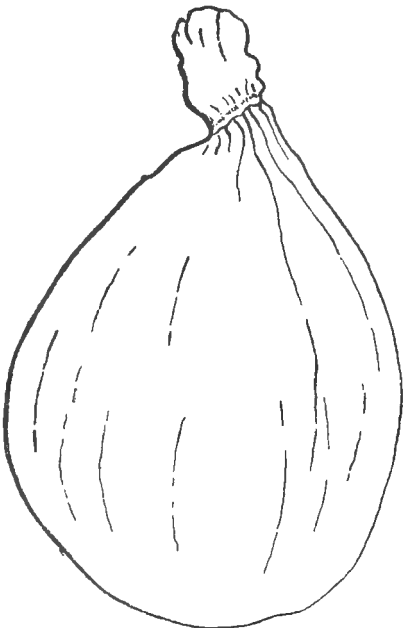

White Adriatic.

**BROWN TURKEY.**—One of the earliest sorts. Tree very prolific, hardy, fruit large, oblong, pyriform; skin brownish red with darker ribs; blue bloom; thick pulp, sweet and good, dark pink colour.

**BRUNSWICK.**—Very large, pyriform, ribs distinct, skin pale amber with a violet tint; pulp amber colour, early and large, but of poor flavour.

**BOURJASSOTTE BLACK.**—A much prized early fig, medium, flattened, black skin, pulp blood red.

**ADAM.**—A fine shade tree, with large leaves, very hardy, fruits late; colour bluish, with a pronounced bloom.

**FIGS FOR STOCK.**—The first important fig plantation for the purpose of grazing stock amongst the trees was established some fifteen years, near Pinjarra, by Mr. Wm. Paterson. The trees were planted 40ft. x 40ft., all side branches were lopped off to send the trees up and permit of grazing. All stock do well on them, eating fruit and also fallen leaves. To secure a rotation, the kinds planted were mostly Brown Turkey, White Adriatic, Adam.

The composition of figs compared with wheat and potatoes is:—

	Fig.	Wheat.	Potatoes.
Water .. . . .	18.8	11.4	78.3
Protein .. . . .	.8	13.8	2.2
Fat .. . . .	.2	1.9	.1
Carbohydrates .. . . .	74.2	71.9	18.4
Food values per lb. .. . . .	1475	1675	385

The figs have, besides their food value, a physiological value in keeping the digestive organs open.

Mr. Paterson advises keeping cattle off; they break down the trees; some horses do too; sheep, pigs, fowls do not hurt. A plantation set out 22ft. x 22ft. was soon overcrowded, and the opinion is expressed that 60ft. x 60ft. would be a better distance than 40ft. x 40ft.

The fig drying industry can only be satisfactorily developed where the late summer and early autumn months are hot and dry. Such conditions occur in Western Australia. The more favourable localities are where the figs undergo a preliminary curing on the tree itself and, when dead ripe, shrivel and droop on the stalk and begin to dry. The foothills is particularly favourable, it is away from the hazy atmosphere of the sea coast, where the ripening of some kinds of figs is not so thorough, and where the fruit still hanging on the tree keep watery, ferment, and turn sour.

When dead ripe on the tree and ready for drying, a sharp shaking of the branches causes them to fall to the ground, when

they are picked up in baskets and spread out in the sun on trays which are stacked up before the evening dew is felt. Hand picking a single fruit at a time would be too lengthy and costly a process for drying.

### THE GRAPE VINE.

Probably no other more rustic plant is suitable for intense culture than is the grape vine. It is particularly well adapted for the conditions of soil and climate that portion of the South-West of Western Australia presents which extends from the Leeuwin to the Murchison River. On that belt, stretching between the Darling Range and the coastal sandhills, it can be profitably cultivated almost anywhere.

In the following notes the kinds recommended are grouped under the three classes of Drying, Table grapes, and Wine grapes.

#### FOR DRYING.

In France the period of ripening of wine grapes has been reckoned by Pulliat from the time of ripening of the Golden Chasselas thus:—First period of maturity, to which belong all vines which ripen their grapes five to six days before or after Golden Chasselas. Second period of maturity, including all vines ripening their grapes 12 to 14 days after Chasselas. Third period, including those ripening their grapes 24 to 30 days after Chasselas. Fourth period, including those ripening their grapes 36 to 40 days after Chasselas. Fifth period, including those grapes which ripen later than eight weeks after Chasselas.

**WHITE MUSCAT OF ALEXANDRIA.**—An oval white Muscat grape. Season medium; will keep in good condition long after ripening. Merits: medium to first class; the most handsome and valuable table and drying grape in cultivation. Extensively cultivated for raisins in Valencia and Denia, in Spain, and also in Southern California, the Cape, and Australia. Vine: A short, rather straggling and bushy grower, well adapted to short spur pruning, as it forms rather a bush than a vine; very free fruiting, but the bunches sometimes set badly, except where local circumstances are favourable. Leaves of medium size, round, bright green above, light green below, deeply lobed, somewhat wrinkled, commencing early to turn, and becoming yellow round the edges. The leaf-stalks, or pedicel, and veins reddish; young shoots a light green. Wood gray, with darker spots, short jointed. The laterals produce a second, and even, sometimes, a third crop. Fruit bunches very long, from 12 to 20 inches, loose, tapering, and often strongly shouldered; a somewhat shy setter. Berries very large, long ovoid on stout stalks. Skins rather thick, clear greenish yellow, or, when

highly ripened, pale amber, and sometimes with a flush of cinnamon where much exposed. Flesh firm, crackling, or fleshy, exceedingly sweet, rich, and with a strong muscatel flavour.

*Cultural Notes.*—Although the vine is hardy and fruits freely, at an early age it is found to require a warm temperature and drier atmosphere than most other varieties to set the berries properly, and ripen the fruit thoroughly; and on that account rejected from general extensive cultivation, except where those conditions prevail. Experience has proved it to be a safe vine to grow in Western Australia from the latitude of the Murchison at the North to that of the Murray and even beyond in favourable locations. Affected by the oidium and anthracnose. Deep Red Gum soil more suitable than our heavy White Gum soils.

Muscateles for drying are thus trained around Malaga where a considerable raisin-drying industry exists. It is found there that a low head, 5-7 inches above ground, carrying 6-8 spurs of two eyes only each—counting the axillary or base eye—give bunches which naturally rest on the ground, and that these low canes are the best and produce the best raisins. Grapes from taller pruned vines seldom have the same sweetness and are often scorched by the sun or scalded by hot winds.

If the grapes are not of good quality, the number of spurs is reduced; if superior, it is increased so as to get the greatest yield of first-class grapes. There is nothing gained in leaving more eyes than two. If more eyes are left, the lower ones will not develop and the result will be to lengthen the arms, increase the size of the head, and place the leaves and grapes further away from the centre of the vine and the spring of sap.

MUSCATEL TORPO BLANCO.—So similar in many respects to Muscat of Alexandria that the one is sometimes confounded with the other. A seedling of Muscat of Alexandria, much cultivated in Spain; the best type of raisin grape of Malaga and known in commerce after that name. Fruit bunches, a closer bunch than Muscat of Alexandria; fruit sets better as a rule; berries rounder, a crease often found at the apex. Skin inclined to be a little darker in colour, and not nearly so green when ripe. Flesh not quite so hard as Muscat of Alexandria. Thicker and finer bloom than Muscat of Alexandria, which loses its bloom very rapidly when packing and drying. Muscat of Alexandria has to be dried a little more than Muscatel to ensure its keeping condition. The same treatment suggested for Muscat of Alexandria applies in the case of this grape.

SEEDLESS MUSCAT.—As a variety does not exist, but it often happens that bunches of muscats carry a number of small seedless berries from imperfectly pollenised flowers, an occurrence known by the French as "millerandage" and by English growers



as "shot grapes." These berries, after the raisins have gone through the stemmer and graded, are kept separate and packed and sold as such, the demand being active and an advanced price.

**SULTANA** (syn. Seedless Sultana, Sultanieh, Sultanina; in California, Thompson's Seedless; in England, Lady de Coverley; in Asiatic Turkey, Kismish, a term given to seedless grapes of which two are cultivated—the "round-fruited" and the "oval-fruited" (also more valuable one, which is here described):—Vine: growth strong, upright, with long climbing canes; bark rough, and tearing in long strips. Wood: very long and strong canes, long-jointed but not very thick nodes; small buds; laterals and tendrils numerous; wood not hard, red brown; bunches carried from the fifth, sixth, or seventh node, hence the necessity of long pruning. Leaves: large, not very deeply lobed, strongly serrated, thin and flat, bright green, smooth and shining above, lighter green and smooth below, die yellow in autumn, long leaf stalk. Bunches large and loose, from 6 to 12 inches long, and 4 to 6 inches wide at the shoulders; stalk long, green, and not woody. Berries: small to medium, oval, skin green, thin but tough, semi-transparent, becoming pale-yellowish as it ripens, covered with light bloom, flesh tender, sweet, juicy, firm, and crackling, of the consistency and flavour of the Sweetwater, and contains no seeds.

*Cultural Notes.*—The defect of this vine is to be a poor bearer unless pruned long; and even the long pruning, as generally practised on other varieties, does not yield the best results. A modification of this is advisable in pruning the Sultana. A sufficiency of laterals which shoot out along the canes should be left on the long rods which are cut back about three feet long. These laterals possess plump buds, and are well summered to the very tip. Train the long rods bearing these laterals along the central wire of a T-shaped trellis, and blind the buds at the joints of rods, except the first two from the stem; bend the laterals about 12 inches long in arcs; they bear the crop. Wood for renewing is supplied by encouraging the vigorous growth of one or two canes at the base of the rods. For that purpose rub off or destroy all barren shoots, and only leave on the fruitful laterals sufficient wood to carry a crop commensurate with the strength of the vine. This is done by pinching the shoots from these fruitful laterals back to the eighth or ninth leaf and limiting the length of the rods to about three feet only.

The Sultana does well in deep, fresh, alluvial soil with good natural water and air drainage. In Australia it is grown on strong and gravelly soil. It matures its crop towards the end of the middle season, and is a good packer as well as an excellent raisin grape. Subject to oïdium and to anthracnose or "black spot."

Late pruning, by delaying the spring growth, often helps to ward off the early attacks of this fungus. The grapes begin to colour and sweeten several weeks before the Muscat, but they become fully ripe later than this variety. Suitable for districts with long summers and autumns. If the dipping process is used in curing, the grapes must be very ripe, else they will turn reddish and dark and lose quality. A little salad oil is put with the lye in Greece to keep the colour "amber." At the Wagga Wagga experimental orchard it was found impossible to graft the Sultana, with any degree of success, upon the following sorts:—Gros Guillaume, Royal Ascot, Corinth Currant, and Solonis. Sultanas grafted on 15 varieties of American stock grew vigorously, and carry good crops of large compact bunches.

**BLACK CURRANT** (syn. *Zante*, *Passerina nera* in Italy).—A corruption of Corinth, the Greek port from which most of these are shipped; the berries resemble currants in size. The home of the Black Currant is the Grecian Islands, as well as Morea, especially around Patras, Zante, Cephalonia, and Ithaca; all produce currants of the highest quality. Vine: growth erect and climbing, moderately robust and very fruitful. Leaf medium size, fine lobed, smooth above, and downy beneath. Fruit: Bunches from four to six or eight inches in length; tapering, and cylindrical, with long, loose shoulders; stalks slender. Berries very small, about the size of small peas, round, Skin, purplish red. Flesh: juicy, sweet, pleasant, and without seeds. Ripens between the 1st and 2nd period; on the Swan, middle of February.

*Cultural Notes.*—The vines in Asia Minor are grown on low bushes, and are pruned short; the young branches requiring staking in order to bear well; the crop ripens in succession from the first shoots, and the laterals, which also bear. For Australia, T head trellising, as shown previously, has been found to answer well, although the ordinary two-wire trellis is now generally adopted. The Currant grape, generally seedless, sometimes produces full-sized large berries with seeds, reverting to the grape as it were; and where this tendency is very marked its cultivation has to be abandoned. This vine is not suited to clayey soils if wet and cold, but does well on a light free loam or when heavily manured with bone dust on sandy loam over a clay subsoil.

To Mr. W. C. Grasby is due the credit of having introduced the system of cincturing the vine to make it fruitful, a method followed for that purpose in Greece and which has already been referred to in a previous chapter. At the University of California fair crops have also been obtained by grafting it on phylloxera resistant stocks.

**WHITE CORINTH.**—The bunch and berry resemble the Black Currant, but differ in not being black, and in lacking the peculiar

aroma and flavour alone possessed by the black and true currant. The absence of pips in currant grapes is due to a malformation of the floral organs. The vine possesses many of the characteristics of the previous kind and will bear even without cincturing; also with the same treatment that succeeds with the Sultana. The berries are intermediate in size, between the Black Currant and the Sultana, but not equal to either in flavour.

#### EXPORT GRAPES.

Western Australia offers special advantages over the other States for the cultivation of export grapes. Its geographical position places it a week to ten days nearer the overseas markets of Europe, India, China, and Malaya, where we are able to place our grapes in the spring of the year; whereas the Spanish grapes are marketed in the winter months, when the demand is not so active. The test of time, besides, has proved that its climate, characterised by rainy winter and spring months followed by dry summer and autumn, ensures a more satisfactory ripening of the grape crop, which can be raised to a degree of perfection required in a first class export fruit without the additional cost of irrigation. To the late Mr. Geo. Barrett-Lennard is due the credit of having demonstrated the practicability of growing grapes for export market, an industry which is now receiving a considerable amount of attention along the Swan River Valley, in close proximity to the port of shipment at Fremantle.

In Western Australia grapes for export are packed in neat hardwood, mahogany-like boxes containing 25lbs. of fruit, in addition to 4lbs. to 5lbs. of cork dust, and they are kept during the voyage in the ship's cool chamber at a temperature of 32° to 34° F.

Although several kinds of grapes have been shipped with more or less success, the following few stand the long sea journey best.

**MALAGA RED** (syn. Red Olivette, Pause Rose, Corezon de Galle, Red Portugal).—Plant not very strong. Bunches long, handsome, well filled with very large olive-shaped berries of a dull-red colour, with thick skin. Ripens late. Subject to Black Spot, and requires careful attention. A characteristic of this variety is the nature of its leaf, the lobes and teeth of which are rounded off. It is bare underneath with the exception of a few short hairs about the nerves. Hangs late.

**MALAGA, BLACK**.—A better carrier than Red Malaga; not so subject to fungoid diseases. This grape grown on a light loam usually carry as well as Ohanez, is more juicy, and has a better flavour.

**FLAME TOKAY** (syn. Red Amar of Kabylie).—Vigorous growth, heavy joints, and leaves large, light yellowish-green in colour, lightly lobed, long toothed, smooth on both sides,

Bunches large, moderately compact, shouldered, conico-cylindrical, thick peduncles. Berries large, longer than wide, flattened at the ends, red, covered with lilac bloom, green where too much shaded; fleshy and crisp; ripens late. A very showy grape and a good packer; quality indifferent; bears well either short or long pruned, and does best on clayey soil. On damp sandy soil fails to colour well. One of the most showy grapes grown. Does very well trained on overhead trellis. Subject to Black Spot.

GROS COLMAN (syn. *Dodrelabi* of Caucasus).—A round, black vinous grape; season late; very handsome and valuable kind for late winter and market purposes; second rate as to quality. Vine: free-vigorous, the shoots stout, with large prominent buds; very fruitful; wood long, stout, not hard, with abundant pith, long joints; buds large, slightly downy. Leaves large, broad, very downy, often presenting the appearance of flagging, and very early in the season assuming a rusty appearance, from which they change to a dull reddish hue, which is very ornamental. Fruit: bunches medium sized, rather short and broad, with usually one large shoulder, giving the bunch a one-sided appearance, sets very freely; stalk long, thin, but very tough and strong. Berries very large, round, sometimes inclined to oblate; the style-point depressed. Skin thick though adhering to the flesh, dark purple or black, covered with a thick bloom. Flesh firm, coarse, and generally with an indifferent flavour, but when highly ripened and commencing to shrivel it is pleasant.

*Cultural Notes.*—A very strong-constituted vine, doing well, like the Alicante, in many localities, and also requires plenty of heat to ripen to perfection. The enormous size of the berries and weight of the bunches necessitate some care in thinning and not over-cropping—an error of treatment which is soon apparent in the want of colour. Requires spur pruning. In damp soil, or when highly manured with organic fertilisers, the berries split and become mouldy.

CORNICHON PURPLE (syn. *Pizutello*).—Vine a vigorous and erect grower; thick, light brown, short-jointed wood; leaves large, fine lobed, dark green above, lighter and hairy below, coarsely toothed, with thick, short petiole; bunches very large, loose, on long peduncles, and on this account easy to pack, even when the bunches are very large. Berries large, long, and curved, darkly coloured and spotted, thick skinned, firm, on long pedicels; ripens late; of attractive appearance and a good packer. Pruned short.

OHANEZ (also written Joannès—the J being silent, also Daria and Almeria, after the province and the port of shipment).—A Spanish variety of splendid shipping qualities and largely exported from the ports of Almeria and Malaga to London and New York. Vine vigorous; leaves medium size, and lightly lobed,

smooth on both faces; teeth obtuse and alternately large and small. Bunches evenly set; loose berries, white, medium to large, long oval, flattened on the ends, hard and fleshy, which prevents them from drying up; strongly attached to the stalklet or pedicel. If a single berry is pulled off the bunch the pedicel breaks clean off from the main stalk and remains attached to the grape, saving it from decay. Flavour indifferent. The vine requires a warm locality and large development, with long pruning, with laterals on the canes as explained in the case of

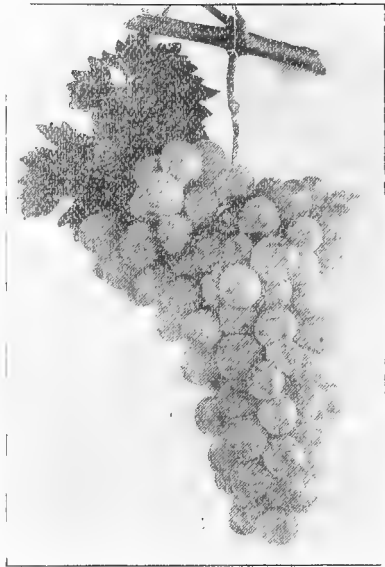

Ohanez.

Sultana. It is sent out from Spain, packed in cork dust or little chips of cork of about one-eighth inch in size. This prevents close packing and does not favour the growth of mould. This grape is successfully shipped to England from Western Australia as well as from the Eastern States. It is the safest grape to ship, and until lately much neglected because it had proved an unreliable bearer. Now, however, it is proved, like the Sultana, and is found to be a prolific vine. In the case of these two vines the fruiting buds are not so much on the main canes of the previous spring's growth as on the laterals or secondary growth off these canes, being really summer growths. The Ohanez and the Sultana throw out these laterals readily. The beautiful trellis erected by Mr. George Barrett-Lennard at Belhus, on the Upper Swan, as shown on the plate attached, is built on more substantial lines than those one sees around Almeria, and the result so far has proved quite as satisfactory. In Spain these trellises are high enough to permit horses and mules working underneath. The single stem is carried about 8ft. high, and the skeleton of the vine spreads overhead on longitudinal wires in conjunction with cross wires, making a kind of large-size netting. The vines are planted 18ft. to 20ft. apart. The high trellis, besides offering all the room required for working, allows plenty of air and light to exercise their beneficent influence; the grapes hang underneath the leaves, which protect them against the

sun; the ground, besides, being sheltered from the direct rays of the sun keeps cool and moist, and a vigorous growth is thereby encouraged.

#### TABLE GRAPES.

Apart from the export grapes mentioned, and which are also of value for the local fruit market, the following varieties are recommended.

**EARLY MADELEINE** (syn. Madeleine Angevine).—Vine a vigorous grower, bursts into leaf and blossoms early, and for that reason unsuitable for frosty localities. Suitable for either eating or wine making. Prune half-long or long. Leaf medium, deeply lobed, somewhat woolly below. Branches medium size, fairly compact and not always well set unless artificially fecundated with a camel hair brush or by running the hands over the blossoms; berries medium, oblong, greenish white, turning to golden when ripe. Hangs well on the bunches. Does well trained on trellises.

**CHASSELAS OF FONTAINEBLEAU** (syn. Royal Muscadine).—A round white grape, of the Sweetwater type. Season early. Merits: first class as to quality and earliness; it will also keep in good condition long after becoming ripe; packs well. Vine: growth free and vigorous, with a fine constitution, the young shoots slender but ripening well; wood brown, long jointed, slender, but ripening well; very fruitful. Leaves small, roundish, thin, lobed, bright green end of shoots and young leaves, brownish green. Leaves dying off early a pale yellow colour. Branches medium sized and small, long, tapering, broadly shouldered and somewhat loose; compact and freely set. Berries medium, round, pale greenish yellow, becoming transparent when fully ripe, or, if exposed to the bright sun, the one side becoming of a bright cinnamon russet, in which condition they are very much richer and sweeter. Flesh firm yet tender, crackling, juicy, sweet and agreeable to the palate. When kept until they begin to shrivel they are very rich.

*Cultural Notes.*—A standard early table grape; makes fairly good wine; ripens a fortnight before Black Hamburg. Generally pruned short.

**CHASSELAS VIBERT.**—A better bearer than the preceding. Young shoots reddish and glossy. Bunches well set, berries green. Good for eating and for wine making.

**CHASSELAS OF NEGREPONT.**—Must be allowed to hang until quite ripe, when it turns from a pale green to a bright red, changing to violet. Possesses a fine appearance and a pleasant aroma, also makes a clean, clear white wine. Ripens after Chasselas of Fontainebleau. Vigorous grower, spreading; canes long, thin, few tendrils, young leaves round and red; leaves medium size, green and glabrous, re-

main green in autumn. Bunches medium size, cylindrical, thick, regular; peduncle short, slightly coloured; berries medium size, larger than Chasselas Rose or Chasselas Violet, spherical, firm. Very fertile; sets well. One of the Archipelago grapes.

GRAND CENTENNIAL.—A sport of Waltham Cross raised in Victoria. Vine very vigorous. Leaves large, wood strong. Bunches large to very large, shouldered loose. Berries large, oval, greenish yellow, of irregular size, with a tendency to crackling; fleshy and cracking when ripe; few seeds; very handsome. Succeeds well on deep, fresh loam.

WALTHAM CROSS.—Berries large, oval, amber coloured, very sweet. Make a fair raisin. A profitable grape.

MADRESFIELD COURT.—A black oval muscat grape. Fairly early to mid-season, excellent in quality and very handsome. Vine: moderately strong grower; wood with prominent dark brown buds, often covered with a thin coating of down. Leaves medium sized, rugose, deeply lobed, deep green, leaf stalk and ribs reddish; leaves die off crimson. Bunches large, long, and tapering, well set; the point often forked; shoulders small, stalk stout. Berries large, oval; skin tough, dark purple, covered with large blue bloom; flesh thick, greenish, tender, and sweet. Said to be a cross between Muscat of Alexandria and Black Morocco.

RED MUSCAT OF FRONTIGNAN (syn. Grizzly Frontignan, Muscatel-Constantia in W.A.).—A round red or tawny Muscat grape. Season: mid-season (third period). Merits: first-rate in quality, but rather small; makes a luscious wine. Vine: growth strong, free, and ripening freely; very fruitful. Wood: spreading shoots of a brown-red colour, thick but short internodes, not very prominent nodes. Leaves medium sized, as broad as they are long, three or five lobes, deeply toothed, very thin; upper surface of a fine grey colour and glabrous; under surface of grey colour, with a few stiff hairs covering the veins, which are slightly prominent, yellow and smooth, dying off yellow. Fruit: bunches medium sized, rather long, somewhat cylindrical in shape, but occasionally shouldered; generally well set. Berries medium sized, round, closely set. Skin thin, membranous, of a dull red or tawny colour on the side most exposed, and paler on the shaded side, generally covered with a thin bloom. Flesh very firm, with a very rich, pleasant, and decided muscat flavour; when kept hanging on the vine after being ripe the fruit is very apt to shrivel, but is then exceeding rich and excellent. There is a white variety which answers the same description.

*Cultural Notes.*—Extensively grown in the South of France and in Australia, as well as at the Cape, where, blended with Tinto, it makes the "Constantia" sweet wine. Imported from the Cape into Western Australia in the early days, and is generally known locally

under the name of "Constantia." The buds burst early and are subject to spring frosts. Pruned either short or long, preferably short for wine making, as the juice of the grape is then richer and its density heavier. A hot, strong, and well-drained soil produces a must of high quality. Bears well on the limonite ironstone gravel, particularly if trellised. Makes a very good fruity wine. Somewhat subject to the attacks of *oidium* and *anthracnose*.

KICHMISH ALI VIOLET.—Much like Black Hamburg, but superior to that grape.

RED PRINCE.—A handsome, oval grape; loose bunch; a good packer. Mid-season, sells well in London.

HAENAPOP (syn. Bouteille a large panse).—Introduced from Shiraz (Persia), a vigorous grower and productive bearer. Bunches large and shouldered. Berries oval, fleshy; skin amber colour, tough; prune short. Largely grown as a table grape in the vineyards of Constantia, on the foothill of Table Mountain, near Cape Town. North of Cape Colony indifferent success has, at times, met the efforts of the growers when grafting *Hœnapop* on *Rupestris* stock, whilst most satisfactory results are obtained when *Jacquez* or *Riparia* stocks are used.

RAISIN DES DAMES (syn. Bicane, Panse jaune).—Does not set well in poor soil; requires long pruning. Bunches large, winged, conical, and loose. Berries very large with small ones amongst them, oval, of a yellow amber colour when ripe, thick bloom; flavour indifferent, very showy, and a good packer. Vines vigorous, long straight canes, leaves medium size, dark green above, glabrous, very little down at the angles of the ribs on the under surface. Fruitful, but a bad setter unless frequently pinched back at blossoming time.

ROSE OF PERU.—Vine a strong grower, with dark brown, short-jointed wood; leaf deep green above, lighter in colour and downy below. Bunches large shouldered, rather loose; berries large, round, purple turning to a darker colour, firm, and crackling; ripens late: a handsome grape and productive vine. Pruned either short or long.

CORNICHON BLANC (syn. Santa Paula, Lady's Finger, Testa di Vacca).—Very similar to Purple Cornichon. Leaves not deeply cut, bright green and smooth on both sides; skin thinner than the previous one, and for that reason better for the table, but poorer packer; very often one single large seed. Suitable for warm districts. Requires long pruning, even though the canes may appear slender.

DORADILLO (syn. Jean Blanc).—A white Spanish grape, suitable as a late table grape and for making a light wine, and also in Spain for *lexia*, or third-class raisins. Season late. Merits: much valued for export and useful for making a light wine or



brandy. Vine: growth—a hardy plant, erect grower, requiring neither trellis nor stake. Fruit: bunches moderately loose; berries large; skin white, slightly amber colour on sunny side, thick. Flesh firm and sweet.

*Cultural Notes.*—Pruned short. Admirably suited for warm districts, where, in a fertile soil, it will bear an enormous crop. Its thick skin and firm flesh are qualities which fit it as a good packing grape, preserving it from drying up, or being crushed out of shape. Large quantities of this grape are shipped from Adelaide to Sydney, long after the bulk of the N.S. Wales grapes have ripened, and thus command a very good price.

GRAND TURK (syn. Cinsault, Danugue).—A vigorous grower, semi-erect, carries its grapes some distance from the butt of the cane, and bears heavily when pruned long. Canes long, straight, thick, hard, with small pith, streaked. Buds burst a few days after Golden Chasselas; young leaves, round, green, hemmed with brown red. Fruit ripens late in mid-season. Bunches very large, conical, winged, regular in outline; peduncle very strong; berries not too closely set, very large, spherical, firm, skin thick, black violet in colour, heavy bloom; flesh firm, sweet, and pleasant. A Provençe variety, very productive, sets well, stands great heat and hot winds. A vigorous grower, very suitable for high trellising.

WORTLEY HALL (syn. Trifere du Japon).—Vigorous grower, leaves smooth and glabrous. Berries very large, thick bloom, ripen late, bears a second crop in April; a good grape for preserving.

GREENGAGE OR LATE GREEN (syn. Leather Jackets).—Very hardy and vigorous, late in ripening.

#### WINE GRAPES.

Of these a number offer for selection amongst the kinds already established in Western Australia, while many more unprocurable here are naturally omitted as the introduction of grape vines is absolutely prohibited in order to shut the door effectively against the introduction of the phylloxera pest of which this State is free.

#### RED WINE GRAPES.

ARAMON (syn. Fontainebleau in W.A.).—Round, black, vinous grape, popular in the South of France and Algeria, on account of the heavy yield of light red wine it produces. Season: mid-season, or third period of grape ripening. Merits: second-rate, and on rich alluvial flats only third-rate; produces a light red wine of quick maturity; made also into a light white wine, which is either sold as such or distilled for brandy. Vine: stem strong and very vigorous in rich soils; spreading habit

of growth, producing whenever topped a great mass of young shoots, which are remarkably brittle. Shoots of a light-red colour in summer; greyish in winter. Buds of a dirty-white colour; much developed. Rods strong, short-jointed. Leaves large; not deeply indented; upper side glossy, under side covered with loose down; petiolar sinus open; dies off yellow. Fruit bunches large and long, almost cylindrical, or slightly shouldered with a brittle herbaceous stalk, which remains green after the ripening of the grape; very regularly but closely set. Berries large, round. Foot-stalks thick. Skin of a dull, purplish-black colour, with a thin bloom; very thin, thus exposed to bursting and rotting in damp soil. Flesh tender, juicy, with a very brisk, rich or strong vinous flavour, when well ripened, and tolerably good for table.

*Cultural Notes.*—A remarkably free fruiting vine wherever grown, requiring a considerable amount of heat to ripen the fruit thoroughly. On rich, deep, and free alluvial soil, and under irrigation, over 3,000 gallons of grape must have been obtained per acre; does not do well in poor and cold soils. On account of the brittleness of the stalk no knife is required to pick the crop, which is thus gathered in less time. Comes into leaf early, and is, therefore, liable to suffer from late frosts; is subject to the *oidium*; pruned short; cultivated for quantity more than quality. The grape being juicy, the must represents as much as 66 per cent. of its weight; whereas in the case of most other grapes, the ratio is 60 to 65 per cent. only. In France, the wine made from the Aramon grape is light in colour, and only contains 9 per cent. alcohol, and in the plains the average yield is about 800 gallons; whereas in Western Australia the average yield is 400 gallons, and the alcoholic strength 11 per cent. The wine matures quickly, and is generally consumed the year of its making.

ASPIRAN (syn. Verdal Spiran).—One of the choice varieties of the South of France, where quantity more than quality is sought for. Season medium (third period). Merits: second rate; produces better wine than Aramon or Mataro. Vine: growth rather vigorous; shoots semi-erect, slender, with medium-sized joints of a light-red colour; buds slightly downy. Leaves of medium size, five-lobed, deeply indented; teeth deep, uneven, which gives to the leaf a feathery appearance; upper surface yellowish green and smooth; under surface with slight woolly down near the veins; petiolar sinus almost closed; and leaves die with a red margin, also the stalks. Fruit: bunches medium size, somewhat shouldered, close set, cylindro-conical. Berries: medium size, slightly oval; skin rather thick, of a purplish black colour covered with bloom. Flesh: very juicy, of a slight acid taste, making it a pleasant table grape as well.

*Cultural Notes.*—Is pruned short and trained bush fashion. Produces in warm localities a pleasant wine of fair keeping qualities, but light colour; a good bearer, producing from 200 to 400 gallons per acre. Comes into leaf medium early, but does not suffer from spring frost. Grows best in a deep, free soil, preferably gravelly, and of a reddish colour. Not much subject to fungoid diseases.

CARIGNANE (syn. Carignan).—A useful grape for the drier and hotter districts. Does well about Toodyay. Season medium (third period). Merits: combines in a happy degree both quality and quantity wherever the circumstances are favourable. Vine: growth of stem thick and vigorous; an erect grower. Shoots: strong, thick, and hard, hence the name it often goes by—*Bois dur*; tips of shoots seldom ripen properly; short-jointed at the base, of a light-red colour, turning to brownish-red in the autumn; young shoots as they burst are downy and slightly pink on under margin. Buds dark in colour, and rather large. Leaves large, rough, and wrinkled; five-lobed; sinus deep; upper surface dark-green and smooth, under surface light-green and slightly downy; leaves turn red in the autumn. Fruit: bunches large and well-set, subdivided into small bunches. Berries: medium size and slightly oblong; black, juicy, and rich.

*Cultural Notes.*—Prune short and train bush fashion. Very subject to fungoid diseases, therefore moist and damp localities are unsuitable for its cultivation. Grapes ripen fairly early, but the buds burst late, thus escaping spring frosts. Requires a good deal of heat to bring it to maturity. Does best in well-drained soils of good consistency. The wine is better on the hills than on the plains, is generous, keeps well, spirituous, possesses a rich dark colour, but is a little coarse and harsh. Sometimes the wine is of a bluish-colour when the grapes have been allowed to get over-ripe.

CABERNET SAUVIGNON (syn. Petit Cabernet).—One of the choicest red wine kind of France, making the high-class Medoc. Season: mid-season (third period). Merits: of the highest as to quality, but giving a small crop, particularly in a dry climate, and therefore unprofitable. Vine: growth vigorous when young, somewhat spreading, but on unsuitable soil grows weak with age; shoots of a dark-reddish mahogany colour, of medium thickness, long joints; buds medium size, downy. Leaves very characteristic, medium sized, as long as they are broad; five-lobed; the indentation or sinus deep, rounded, and overlapping towards their extremities in such a way as to make the leaves appear as if they were pierced with fine holes; teeth sharp and uneven; upper surface of a dark-green colour, smooth and glossy, but uneven; under surface covered with close, short down. Fruit: bunches medium

size, conical, slightly shouldered, and rather loose, slender peduncle. Berries, small, round, on a long and slender foot-stalk, which turns red as the grape ripens. Skin thick, hard, and black, covered with a fine blue bloom when ripe, apt to fall off when over-ripe. Flesh hard and juicy, with peculiar flavour, which is common to the Cabernets.

*Cultural Notes.*—Requires long rod pruning; rather subject to *oidium* and *anthracnosc.* and should therefore be grown in perfectly well-drained soil, such as a rich loamy soil mixed with gravel. Does well also on ironstone gravel underlying a rich loam, whether light or heavy, and not so well on limestone soil or on heavy marl. Does better when grafted on a stronger stock, such as Mataro, or better still, on American phylloxera-proof stock. Suitable for the cooler districts. It forms in the Bordeaux district of France the foundation of the first growths of the world-renowned Chateau Lafite, Chateau Margaux, Chateau Latour, etc., where it is blended with Malbeck, Merlot, and Verdot. Blended with Malbeck and Shiraz, and other good sorts, it makes a most suitable wine for either the local or the export market. The wine, which possesses a deep and brilliant ruby colour, is rather harsh at first, but mellows down with each racking. Keeps very well, and is remarkable for its bouquet. A good average yield would be 150 gallons to the acre.

**CABERNET GROS** (syn. Cabernet Franc, Carmenet).—This variety differs but slightly from the Cabernet Sauvignon, from which it is difficult to be distinguished; yields a better crop. Season: a little earlier than previous one (second period). Merits: very nearly as good as Cabernet Sauvignon. Vine: growth vigorous. Shoots: semi-erect, of a paler colour, grey, yellowish-red. Leaves: medium; similar to C. Sauvignon, but coarser and less glossy; holes not so well marked. Fruit: bunches rather smaller than C. Sauvignon. Berries: larger with thinner skin; ripens a little earlier.

*Cultural Notes.*—Is not superior to the Cabernet in any respect, and will not do in a limestone country. This is the variety recommended where autumn rains are frequent, being hardy, and will stand a lot of wet before rotting. The wine from this variety is, at first, very astringent, but loses that rapidly, and is fit for bottling—earlier than that made from C. Sauvignon.

**DOLCETTO** (syn. Uva d' Acqui).—This grape does well on the moist flats and valley lands of the South-West. It is widely cultivated on the higher valleys of the Piedmontes Alps, notably at Alba and Acqui, where a good commercial red wine is made from its juice.

Vine vigorous and fruitful. Wood: filbert colour, short-jointed. Buds: large and whitish before bursting. Terminal shoots; the

young leaves are red, and covered with a light whitish down. Leaves: medium size to large, broader than long, smooth and almost glossy above, very slightly woolly below; three or five lobes; lines, round and deep; teeth pointed; tendrils, leaf-stalks, and ribs, reddish. Bunches: medium size, pyramidal, long-shouldered, well set, with a long brown stalk. Berries: medium size, almost round, bluish-black, covered with bloom, thin-skinned, juicy, and sweet; often falls off the bunches when very ripe.

This grape ripens early, bears heavily, and makes a light sweet wine, which matures fairly quickly, and is superior to that made from the Mataro grape. Requires long pruning.

**GRENACHE** (syn. Roussillon, Alicante).—Grown extensively in the south of France and Spain, where it largely enters in the manufacture of the Tarragona port valuable as a commercial rapidly maturing fruity tawny wine. Season: mid to late season (third period). Merits: combines quality with quantity; wine matures quickly and loses its colour early, and for that purpose very suitable for making a sweet wine of the port type. Vine: growth very vigorous, semi-erect grower; shoots short-jointed and tapering with swollen buds of a yellowish colour, and often unripe towards the extremity; young buds green and almost smooth, burst soon after Aramon and a few days before Carignane; leaves medium size, smooth and glossy on both sides, slightly lobed, with sharp teeth on the margin of a yellowish-green colour, turning yellow in the autumn; petiolar sinus open. Fruit: bunches large, cylindrical, irregular, small shoulder, woody stalk. Berries: medium size, closely packed, slightly oval, not very dark, and of a reddish-blue colour, thin-skinned, covered with bloom, and subject to rotting in damp localities.

*Cultural Notes.*—Not very subject to *oidium*, but easily attacked by *anthracnose* and mildew, or *peronospora*; pruned short and trained bush fashion. Heavy bearer, producing a wine that is rather coarse at first, and not suitable for making wine of the claret type, as it loses its colour quickly, assuming a tawny brown tint very suitable for port; very good for blending with some dark-coloured wine. On rich flats gives an abundant yield of thinner wine; while on gravelly slopes produces a more full-bodied wine. This vine exhausts itself fairly early—after 15 to 20 years. The best results are obtained on granitic or red ironstone sandy soil.

**MALECK** (syn. Côt).—A choice red variety. Season: early (second period). Merits: first-class, and enters with Cabernet in the making of high-class clarets; when fortified makes good wine of the port type. Vine: growth vigorous, half spreading; shoots sharp pointed, average thickness, brownish-fawn colour with red stripes; large buds, light-red to whitish violet. Leaves: of a pinkish white when young, medium sized, three-lobed, circular; upper sur-

face bright green, glossy, and rough; under surface covered with flaky down; leaf-stalk, short and thick. Fruit: bunches large, branched, loose, and somewhat pyramidal. Berries: rather large, roundish, with long thick pedicel. Skin: thin and tough, dark-violet, covered with bloom. Stems: red, especially the extremities, to which the berries are attached. Sweet. Picked when fully ripe the berries readily fall off the bunch; they are also closely set to the wood.

*Cultural Notes.*—Temperate districts are the best for its cultivation, but is also grown in the warmer and drier districts. Requires well-drained soil to set well, preferably rich loam or limestone formations, where it generally gives best results. Pruned with long rods. Suffers but slightly from the *oidium*, but liable to be attacked by anthracnose. Berries ripen a little before Cabernet, but hang well. Makes a beautiful wine of the claret type, with rich ruby colour; rather astringent and bitterish when young, but susceptible of correction by blending. Comes into leaf rather early; and in frosty localities should not be planted in hollows. Unlike most vines, has the peculiarity of bearing fruit on shoots growing off the old wood if the normal fruit-bearing shoots are destroyed.

MERLOT.—Another choice claret grape, and a good bearer; suitable for cool localities. Vine: a strong grower; slim, erect wood, short-jointed, streaked, greyish-fawn in colour. Leaves: medium sized; five-lobed; wider than long; sinus open; teeth sharp and uneven; smooth above, tomentose below; dying off red. Bunches: conical, elongated, shouldered. Berries: small to medium, round, bluish-black, covered with bloom, juicy, sweet, and pleasant. Ripens early (second period). Pruned either short or preferably long. When grown in suitable localities, the wine is velvety and matures quickly; but does not come up to Cabernet, with which it blends well. Does best in cool and moist localities, where its leaves are not scorched, and where the berries hang longer on the vines. One of the best Australian clarets I have tasted was produced from Merlot grapes grown at Bendigo, in Victoria. The vineyard has since been found infested by the phylloxera, and was on that account destroyed.

MATARO (syn. Espar, Mourvèdre, Lambruscat in N.S.W.)—Largely cultivated in the south of France and in Spain, Italy, and Algeria. Season: late (third period). Merits: a good blending red wine, but without much character by itself. Vine: growth vigorous, erect grower: short-jointed wood, of a reddish-brown colour when ripe; large buds. Leaves: medium size, five-lobed, rough and coarse; upper surface dark-green, under surface downy and whitish; leaf-stalk and veins dark reddish-brown; lateral sinus not much marked; petiolar sinus open. Fruit: bunches medium, close, cylindro-conical, small shoulders, hard, woody stalk. Berries;

medium, round; skin thick, black, covered with a thick blue bloom; juicy, and rather astringent.

*Cultural Notes.*—Wine of no special character. Comes into leaf late. Resists all sorts of fungoid diseases well. Pruned short, and trained bush fashion. Heavy yielder; very hardy; grows in any soil, but does especially well on drained limestones and in hot localities.

**MORRASTEL** (syn. Burgundy [?] in W.A.)—A profitable red wine grape. Season: mid-season (third period). Merits: combines quality with quantity; resists diseases well. Vine: strong, upright, fruitful. Wood: thick, pretty hard, of a reddish colour; joints not very long; nodes strong and swollen. Buds, hairy white. Leaves: strong, light green, three to five lobes, not very indented; glabrous on upper surface, and somewhat cottony on underside; leaf-stalk and veins red; dies yellow with red patches. Bunch: large, winged, and conical; berries close set, black, with blue bloom, oblong, juicy.

*Cultural Notes.*—Fruitful in soil well adapted to its growth. Does remarkably well on hillsides, where it produces a wine full of character, with a rich grenat colour, suitable for blending. It also does well in heavy or in loamy soil. The buds burst late, and is therefore late affected by light frost; the bunches set very well; resists well cryptogamic fungoid diseases. Does not do so well in sandy land, where its yield is not so great. In damp places the vine is liable to rot at the crown, and shoots come up again from the roots; in rich soil it grows wood and leaves too luxuriantly for fruit production. The lower buds being fruitful and the growth erect, short pruning suits it best.

**RED MUSCAT OF FRONTIGNAN** (syn. Constantia, in W.A.)—(See above.)

**SHIRAZ** (syn. Hermitage).—Extensively grown in the celebrated Hermitage vineyards of France (Rhône Valley), supposed to have been introduced from Persia. Ripens mid-season (second period). Produces an excellent wine of good colour, body, and keeping quality, particularly adapted for the natural conditions met with in Australia and should constitute the foundation of red Australian wine, both for the local and for the export market. Vine: somewhat spreading, vigorous and fruitful. Wood: long-jointed, strong, of a brown-grey colour in the winter. Leaves: large, of a light-green, somewhat undulating, glabrous on the top and with flaky down underneath; particularly along the veins, fine-lobed, but not very deeply indented; teeth large and blunt. Fruit: bunch elongated, cylindrical, sometimes rather loose, but in well selected vines closer in the bunch, winged, with a long, slender, yellow stalk, which snaps easily when picking; berries medium-sized, oval, black, covered with bloom, thin but tough skin, juicy.

*Cultural Notes.*—In good deep soil, and on slopes, the Shiraz bears heavily and regularly. In light and shallow soil, subject to drought, its fruitfulness decreases greatly, and must be kept up by means of manures. Not very subject to fungoid and insect pests, although it must be kept well sulphured. Yields better crop under rod pruning and on account of its spreading habit of growth, and in order to keep the grapes up the stem should not be too short.

VERDOT.—One of the “claret” grapes. Season, mid-season (3rd period). Merit, first class, although not so much perfumed as the Cabernet. Vine growth vigorous, spreading. Leaves medium-sized, longer than broad, when young covered with a characteristic silvery-white down; when full grown three or five-lobed, teeth uneven, sinus rather open and not very deep; upper surface smooth, uneven, of a paler green than Cabernet, underside downy. Fruit bunches small, shouldered. Berries round, small, dark purple, with several small green berries amongst the others; thick skin, large seeds.

*Cultural Notes.*—Pruned long, like Cabernet. Malbeck, etc. Better bearer than Cabernet, and is often blended with it when grown on the rich alluvial flats (palus) along the banks of the Gironde River, near Bourdeaux. Wine possesses good colour, vigour, and very good keeping qualities. Subject to *oidium*.

#### CHOICE WHITE WINE GRAPES.

CHASSELAS.—(See above).

DORADILLO.—(See above).

CLAIRETTE (syn. Blanquette).—A vigorous vine; leaves glabrous on top and whitish underneath; prune long, bunch well formed, oval berries, grapes hang well, make a clear and pleasant wine; blended with red grapes, assists in extracting colour. Should be planted on well-drained soil on account of anthracnose.

FOLLE BLANCHE.—One of the Sauterne type of grapes, but more widely cultivated in France for the distillation of brandy, under the name of “cognac,” and as a blending wine. It is pruned short; vine a strong grower; canes short and thick, erect, reddish, with medium-length internodes; leaves, medium size, fine lobed, teeth short and obtuse, deep green and shiny above, slightly puckered, downy below; bunch medium size, compact, conico-cylindrical; berries medium to large, spherical, of a whitish green or yellow, according to soil and aspect; skin tough; ripens fairly early (2nd period). It adapts itself to all kinds of rich soils, but sets poorly where early frosts occur and also rots easily in wet autumns.

GOUAIS (syn. Kleinberger).—Vine a strong grower, bunches of medium size, conical, compact; berries over medium size, round, very juicy, without special flavour, ripen late, skin thin; a heavy



bearer; long or short pruning; gives a clean wine, without much character, but fermenting easily; suitable for blending or for distillation.

MARSANNE (syn. White Shiraz).—Vine vigorous; cane strong with long internodes; leaves large, wrinkled, with deep lateral and closed petiolar sinuses; teeth short, wide, obtuse, glabrous above, a little downy below; bunches long, cylindrical shouldered, compact; berries round, white, with a mother-of-pearl shine, juicy. This grape produces a good clean wine of the chablis type; ripens late (3rd period). Spur prune on permanent arms if trellised, otherwise spur prune. When long pruned the berries are uneven and the bunches sometimes dry up at the extremity.

MUSCAT OF FRONTIGNAN (syn. White Constantia).—(See above.)

PEDRO XIMENES.—A grape of the sherry type, rich in sugar and low in acid. It is the principal wine grape of Malaga and Grenada and Jerez. In conjunction with Palomino, it is used in the manufacture of dry sherries and occasionally with the Tintas for the manufacture of red wines. Vine vigorous and productive; slender, short-jointed wood; leaves medium size, smooth, veins light yellow; bunches large, branching, loose but well filled; berries small to medium, somewhat oval, firm, fleshy, of a yellow-golden colour, go off quietly and do not hang long; ripening late. Requires a rich soil and short pruning.

PALOMINO (syn. Listan), also called "Sweetwater" in Australia.—One of the leading sherry grapes. Very easy to pick—the large bunches are torn from the vine.

PINEAU WHITE CHARDONNAY (syn. White Morillon).—Vine more vigorous than most of the Pinots, with slender but vigorous wood; leaves medium size, yellowish green, glabrous above, slightly downy below, teeth uneven; bunches small, short, somewhat compact, conico-cylindrical; berries small, spherical, light green when ripe and golden on the sunny side; flesh firm and of more flavour than the true Pinot Blanc. Ripening early, a week or two later than the Black Pinot. Adapts itself to all soils, but bears better crops in well-drained deep loam. This grape enters to some extent into the manufacture of the best champagne wine, and also those famous white wines of Burgundy—Montrachet, Chablis, and Pouilly. Another white pineau, under the name of Auxerrois, produces in the dry districts of New South Wales and in Victoria a fine sweet white wine.

RIESLING.—A choice white grape of which hock is made on the Rhine and in Moselle. Season fairly early (2nd period). Merits, one of the best varieties for cultivation. Vine growth: stem slender; shoots semi-erect, slender, rather long jointed, hard bark of a glossy

gray colour, turning to silver white in the autumn, numerous laterals. Buds downy, grayish colour. Leaves medium, thick, three to five-lobed, wrinkled, rather deeply indented sinus, teeth almost even; upper surface smooth, dark green; under surface downy, light green colour, veins thick and covered with short stiff hair; petiolar sinus almost closed; leaves fall early in the autumn. Fruit: bunches large, close set, cylindro-conical, with short and thick pedicel. Berries small, round or somewhat oblate, of a greenish colour, covered with bloom and with small black specks; very juicy and rich, with a peculiar aromatic flavour.

*Cultural Notes.*—Long pruning, comes into leaf late; gives best results on granite or schistose formations; fairly resistant to *oidium*, and not attacked by *anthracnose*. Yields fair crops.

**SHEPHERD'S RIESLING** (syn. Orleans Riesling, Gros Riesling).—A variety of the above, bears heavier crops, has larger berries, resists wet better, but the wine not quite so good as that of the true Riesling. Vine vigorous, leaves of medium size, longer than wide, glabrous above, slightly downy below, three to five lobes, the upper sinuses deep, the lower scarcely marked; bunches medium size, somewhat compact, conico-cylindrical, slightly shouldered; berries larger than those of Riesling, slightly ovoid, juicy, whitish yellow. Ripens second period, a little after Riesling. This variety is much grown throughout the Palatinate and the Rhingau, and round Rudesheim. Does not require long pruning.

#### DESIRABLE RED WINE GRAPES.

The following vines, exhibiting characters which would very likely be suitable to conditions which obtain in Western Australia, might with advantage be introduced under the authority and care of the Department of Agriculture:—

**BECLAN.**—Especially suited, says Prof. Bioletti (Bull. 193: "Best Wine Grapes of California"), for certain parts of the coast counties of California, owing to the frequent occurrence of ocean fogs, where many varieties do not ripen their fruit properly. Suitable for dry red wine of good quality; has the advantage of being very resistant to *oidium*. The Blue Portuguese, also a good bearer, ripening easily, blends with Beclan, giving a good wine of the Burgundy type.

**MONDEUSE** (syn. Grosse Syrah).—One of the leading kinds on the Alpine slopes east of the Rhone, where it is grown on the hills and also in the cold, humid valleys. Vigorous growth, straggling. Wood yellowish-green, long joints, leaves long, smooth on top, downy below. Bunch large, long, loose, pyramidal, with a shoulder. Berry medium size, ovoid, bluish violed, juicy and sweet, a little acid and astringent even when ripe. Mid season. Sets well, little

affected by frost and fungoid diseases. Pruned long or even short. Yields well and produces a wine somewhat harsh when new, well coloured and of good keeping.

**TOURIGA.**—Grown at Mt. Athos, Rutherglen, Victoria, and introduced by Mr. F. de Castella, is thus reported by Mr. d'Arbley Burney, Messrs. Burgoyne Bros.' representative:—"Carries a good crop, larger than that carried upon Grenache. Bunches solid and well filled; shows no signs of shrivelling from the heat. Ripens after Shiraz, and standing dry weather better. Resists drought well. Quality of wine shows great promise. A variety recommended for extensive culture."

Touriga, if left in prolonged contact with the skins, would produce a wine of very deep colour. Has a distinctive colour, with a flavour suggesting "vintage port." Grenache treated under identical conditions is a far more neutral wine.

**SEMILLON** (syn. White Ivanhoe in Victoria).—The most largely cultivated Sauterne grape. Regarded as one of the most valuable French white wine sort.

**ROUSSANNE** (syn. White Burgundy in Australia).—On the Rhône it is blended with Marsanne for Chablis; vine very vigorous. Pruned short. Leaves large, lobed, somewhat downy. Bunches medium size, cylindrical, shouldered. Berries medium size, somewhat close, globular, golden-yellow when ripe. (2nd period.)

**VERDELHO** (syn. Gouveio, Madeira in Australia).—An oval-shaped white grape, which makes an excellent white sweet wine of the Madeira type. Season: mid-season. Merits: produces a high-class wine, but the plant is very subject to *oidium*. Vine: growth moderately vigorous; shoots slender, rather close-jointed, of a reddish colour with dark streaks; leaves medium, almost entire, upper side dark-green, smooth, and rather shiny, under surface slightly downy; teeth even, short and blunt. Fruit: bunches medium to small, long in shape and conical; berries small to medium, not very closely set in the bunch, oval, sometimes without seeds; skin thin, yellow-green, does not burst readily in wet weather.

*Cultural Notes.*—Prune long. Vine very subject to *oidium*, and for that reason should not be planted in a moist district. Another good variety is the—

**SERCIAL** grape; a round, white berry, which makes a high-class Madeira wine.

#### PHYLLOXERA-RESISTANT VINES.

These vines, which grow wild in America, offered until recent years but a casual botanical interest. The unintentional introduction of the Phylloxera insect from the New World some fifty years ago soon caused, wherever introduced, the death of all varieties of European vines or *Vitis Vinifera*.

For a long time the methods adopted for combating the deadly insect proved abortive, until a systematic study was undertaken of the conditions under which the *Phylloxera vastatrix*, an insect of American origin, lived on the American wild vines without perceptibly affecting their constitution.

The conclusions drawn from these researches are that by a slow process of natural selection numerous varieties of American wild vines have perished under the bite of the Phylloxera louse, but that several varieties have been able to withstand the attacks of the insect, and while tolerating its presence on their roots, are able to grow without being perceptibly inconvenienced. This much having been found, vineyard proprietors who had hitherto been fighting the Phylloxera by means of costly chemicals or of methods involving considerable outlay of money and of labour, followed headlong the line of least resistance and planted for stock anything known as an American vine; on these they grafted the choicer European vines.

Experience, which is generally costly, showed that of the dozen or more of known species of wild American vines, two or three only, the *Vitis Riparia* and the *Vitis Rupestris*, and the *Vitis Berlandieri*, embodied such qualities as made them desirable Phylloxera-resistant stocks. Fortunes were spent and fortunes lost before this fact was established, so anxious were the vineyard proprietors to speedily reconstitute their vineyards.

Then a Riparia and Rupestris craze set in, and it was argued that as these vines were of a wild nature, and had not been modified by cultivation and by the handiwork of man, their seeds would prove a quick and ready way of propagating the vines. Disappointment likewise followed; a majority of the seedlings proved to be different and inferior in the qualities sought for to the mother plant.

Of Riparias and Rupestris, numerous varieties are known; the great majority of them are worthless as stocks for European vines. Some take the graft badly; others cannot thrive on the particular soil it is intended to plant them; the ground is either too dry or wet, or too compact, or contains too much lime, etc.

It is thus necessary in selecting a resistant vine to know, in the first instance, something about the depth, the moisture, and the richness of the soil it is intended to plant; and, secondly, which of the best varieties as regards aptitude to take the graft and to withstand the attack of the insect is more likely to thrive under the conditions disclosed by that preliminary inspection of the ground.

In Europe, where abundant summer showers maintain the soil moist during the growing months, the shallow-rooted Riparias (river bank vines) have given widespread satisfaction. In California and in Australia, as well also as in Algeria, where the summer months are dry and the surface ground possesses comparatively little moisture, the deeper rooted Rupestris (hillside vines) yield better results,

One important factor, to a great extent, influences the efficacy of all American resistant vines as a suitable stock for vines, and that is: deep and thorough cultivation. On the vigour and the strength of their roots will depend their power to counteract the wasting effect of the sap-sucking insect, and of infusing life and energy into the scion, and unless the ground be deeply stirred, the roots will fail to grow with the same luxuriance they show in easily penetrated soil; the standard of resistance will as a result be lowered and the graft will fail to receive the amount of sap required to produce and nourish a large crop.

By *standard of resistance* is meant that scale adopted by viticulturists all the world over which determines the degree of resistance to Phylloxera possessed by vines. In that table, 20 represents the maximum degree of absolute resistance, while 0 represents its minimum. Thus the resisting power of the best Rupestris and Riparia is 19.50; that of some of the hybrids, such as Jacquez and Leonir, 11 to 12; and that of Chasselas, Aramon, Grenache is 0, or absolutely *nil*.

The resistance expressed by the numbers 16 to 20 is sufficient for all soils; that expressed by 14 or 15 is sufficient, too, where deep, free, moist, loamy soils occur, where roots grow rapidly; while all vines possessing a degree of resistance under 13 should be discarded as non-resistant stock.

The following table, drawn up by Viala, shows the resistance of some of the best known vines:—

*Comparative Resistance to Phylloxera.*

<i>Species (Wild Vines).</i>		<i>Cultivated Vines and Hybrids.</i>	
Vitis Rotundifolia (Scuppernong) .. .. .	19	Gloire de Montpellier (Riparia) .. .. .	18
Vitis Rupestris (Rock or Sand Grape) .. .. .	18	Rupestris Martin .. .. .	18
Vitis Riparia (River Bank Grape) .. .. .	18	Rupestris Monticola (du Lot)	18
Vitis Berlandieri .. .. .	17	Rupestris Metallica .. .. .	16
Vitis Æstivalis (Summer Grape) .. .. .	16	Solonis .. .. .	14
Vitis Labrusca (Fox Grape)	5	Lenoir .. .. .	12
Vitis Californica .. .. .	4	Isabella .. .. .	5
Vitis Vinifera (European Grape) .. .. .	0		

A readily visible external indication of the degree of resistance to the attacks of the insect is afforded by nodosities and by tuberosities on the root. The "nodosity" is a swelling on the tender rootlets of the grape vine, which is caused by the bite of the Phylloxera. All vines attacked by the Phylloxera show more or less these nodosities, which are the result of local irritations. When these nodosities, however, assume a more pronounced appearance, such as deeply-

seated cankers, they become "tuberosities," and the more numerous these tuberosities are on the roots of a vine the less resistant it is found to be to the attacks of the Phylloxera.

To sum up the value of the American resistant vines to use as stock for grafting our European vines on, their degree of resistance is due to the fact—1st, that they are exceptionally luxuriant growers and impart to scion or graft both vigour and strength; 2nd, that the Phylloxera insects do not increase so rapidly on their roots; 3rd, that the swelling of diseased tissues caused by the bite of the insects form at most only nodosities on the roots, and seldom tuberosities or cankered ulcers, and that these swellings rapidly heal and leave the affected part as healthy as ever, little or no inconvenience being suffered by the vine.

Some fifteen years ago our Department of Agriculture introduced amongst a collection of valuable grapes some of the best American resistant vines, a description of which is given below. Although the Phylloxera is non-existent in Western Australia, it was thought advisable to be prepared, if ever the pest should break out, with resistant stock. Since that time Mr. Fr. de Castella, the Government Viticulturist of Victoria, has introduced into Victoria, Phylloxera Resistant Hybrids of particular value for their adaptation to Australian soil and climatic conditions, and for the readiness they carry grafts of cultivated European vines. Should it at any future time be found necessary to reconstitute our vineyards and re-establish them on phylloxera-proof roots, the Australian experience now being gained in Victoria should be of great value.

*VITIS RUPESTRIS* (the Rock or Sand Grape).—Of the two leading species of resistant vines used to graft on, the *Rupestris* offers all the characteristics which should make it a favourite in Western Australia. In Europe, where the climate is moist in the summer months, the *Riparia* is often preferred on account of the readiness with which it takes the graft and the fact that it does not sucker as does the *Rupestris*. With us, however, the circumstances are not the same. The summer months are dry, and a deep-rooting vine stands a better chance of getting a good hold of the ground than does a shallow-rooted one.

For soils that are dry, sandy, or gravelly, the *Rupestris* is therefore the vine to select. Should the ground be moist and fertile it will of course thrive the better, although under these circumstances the *Riparia* will excel it. Thus speaks Professor Viala, a recognised authority on viticulture, on *Rupestris*:—"Among the diverse form of *Rupestris*, we recommend the following from a strictly practical point of view as the most valuable in replanting vineyards: *Rupestris Monticola* (Du Lot or St. George\*), *Rupestris Mar-*

\* NOTE.—The R. du Lot has now proved superior to the other three mentioned which are discarded for the hybrids 3306 and 3309 which are quite satisfactory in Victoria.

tin, Rupestris Mission, and Rupestris Ganzin. These alone should remain under culture. The others, though possessing a certain undoubted value, are inferior, because they lack resistance or all-round adaptability. The Rupestris Martin, on account of its great resistance to the Phylloxera, should always be used in poor, silicious, gravelly soils, with or without a considerable amount of lime. The Rupestris St. George replaces actually the Lenoir and Solonis in poor calcareous soils where formerly the Vialla, Lenoir, etc. were used. The ungrafted Rupestris will frequently show an alarming number of black spots on the leaves, so abundant in some cases as to cause the dropping of a few of them. This is due to the *Melanose*, a disease of the vine that never does any harm at all and should alarm no one. As soon as the Rupestris is grafted this will disappear from the vineyards, as it can scarcely live on the *Vitis Vinifera*, but takes more kindly to the American vines."

The Rupestris have a low, bushy growth, with young wood, reddish brown. Tendrils discontinuous and leaves small, light green and shiny, wider than long, without lobes; when young, transparent

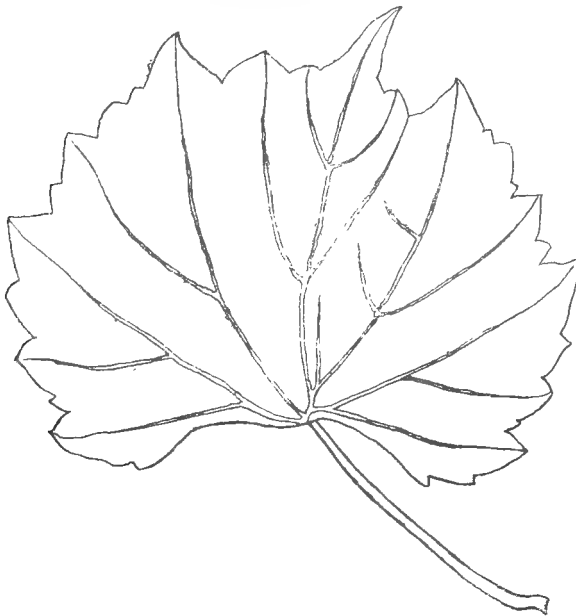

Rupestris Monticola.

and brilliant, of a russet red; they are folded together so as to form a gutter. The sinus of the petiole is open and scarcely perceptible; it has well-marked, wide, obtuse teeth-serration. Berries small,

spherical, in small bunches. Roots deep sinking, long, slender, and very hard, but exceptionally large and fleshy, as in the *Rupestris Monticola* (Du Lot or St. George); grows very readily from cuttings, suckers freely. Of the *Rupestris* there are two groups, classed according as they have small or larger leaves. The second group is the best. They exhaust themselves during youth, and on the whole lack longevity.

*RUPESTRIS MONTICOLA* (syn. *R. du Lot*, *St. George*, *Sijas*) is a stock vine, particularly suited to local conditions of soil and climate in Western Australia. It has so far proved the best adapted variety for the sandy soil of the coastal districts and the gravelly hills of the Darling Range. Mr. F. de Castella is likewise of opinion that it is very suitable for conditions met with in Victoria in any well-drained soil when it can get its roots down, and the soil is not too rich, in which case wood grows at the expense of fruit. An erect grower, stands drought admirably well, on account of its vigorous deep-sinking root system. Unites readily with the European vines, suckers less than other *Rupestris*.

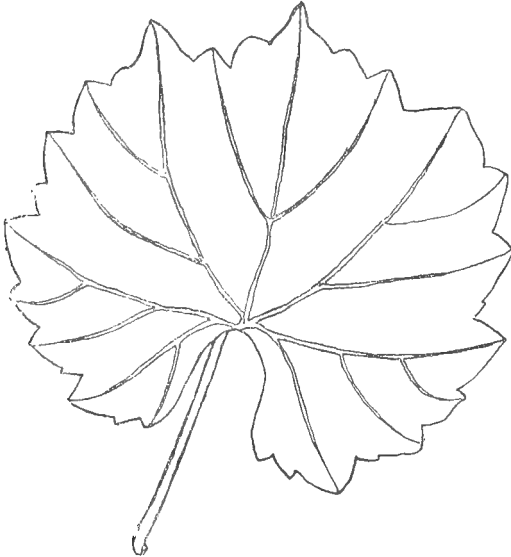

*Rupestris Martin.*

*RUPESTRIS MARTIN.*—Introduced from Texas; suitable for cold clay formations; does not stand drought or limestone formation so well as the above variety, but in every other respect is a good stock; growth vigorous and straggling, canes wavy; leaves heart-shaped, thick, dark green, gutter-shaped, wavy; petiolar sinus, V-shaped; teeth rounded and large.



**RUPESTRIS MISSION.**—Very vigorous and spreading; stands drought well. Leaves small, gutter-shaped, with margins turned in; wood violet red at first, then dark and dull.

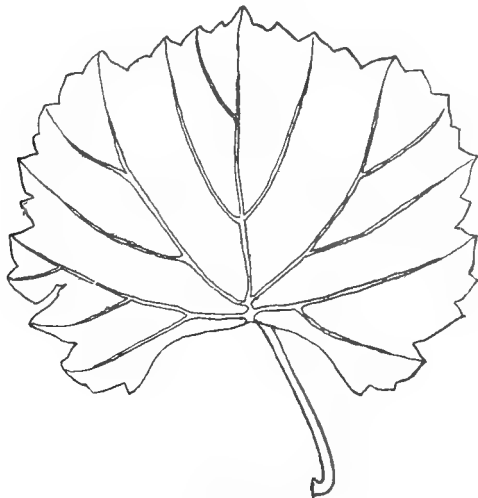

Rupestris Mission.

**VITIS RIPARIA** (River Bank Grape).—In Europe, where the conditions of soil moisture and fertility are frequently met with, the *R. Riparia* is often a favourite, and where these conditions occur it is of all the stock vines the best to use. It is distinguished from other species by having very thin diaphragms at the nodes of the stem, light green, shining, glabrous leaves, almost or quite without hairiness beneath; large stipules, and very early flowering habit.

One advantage the Riparia has over the Rupestris is that it is more easily grafted when old than the Rupestris, and if the stock is planted straight out instead of first grafting and sticking in nursery rows, Riparias stock will, for that reason, succeed more easily. The large-leaved vigorous varieties only should be used and all others discarded. Its only defect is that in the case of some sub-varieties the stock is sometimes more slender in growth than the vine it supports.

**RIPARIA GLORY OF MONTPELLIER** (syn. *R. Portalis*).—A very vigorous variety, with spreading habit of growth. Wood long, light hazelnut colour; long joints with a small kink at the nodes; few laterals, light bloom; young shoots bright purple. Leaves large, roundish, dull, straight hair on the veins underneath. Petiolar sinus open, U-shaped. Especially suited to deep alluvial soils, red loamy, and rich, moist, sandy loamy. Does not do well in soils con-

taining a large amount of soft limestone, where it contracts chlorosis. Takes the graft readily. After trial, discarded as a stock vine in Victoria. Mr. F. de Castella, the Government Viticulturist, favours, instead of the Riparias, hybrids 3306 and 3309, which are good almost anywhere; also A.R. 611. Grafted vines on this stock are very fruitful.

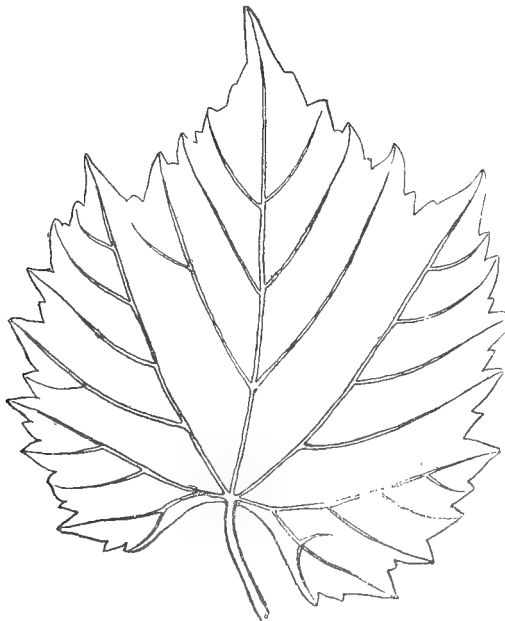

Riparia Glory of Montpellier.

**RIPARIA (GLABRE GIANT).**—One of the most vigorous of the Riparias and capable of withstanding a certain proportion of limestone in the ground; does well in dry, deep soils; straggling grower. Stem slight, canes long, with long joints, purple when tender, turning to hazel nut with bloom; wood very red with numerous laterals. Leaves large, elongated, but not cordiform (the sides almost parallel), shiny, petiolar sinus, V-shaped. The fig, as illustrated, compared with the others is somewhat undersize.

**VITIS BERLANDIERI.**— This variety, also introduced from America, has proved the saviour of vinegrowers on the calcareous soils of the Cognac districts of France, when hitherto every Phylloxera resisting stock tried had succumbed to chlorosis. Introduced into Victoria by Mr. F. de Castella, who expects good results from the B. Hybrids 41B, 420A, 34E. For stiff clays he hopes much from the Cordifolia hybrids; 106-8 is well spoken of.

THE SOLONIS.—Believed to be a cross between *V. Riparia* and *V. Rupestris* and *V. Candicans*. To its first two parents it owes its immunity from the attack of the Phylloxera, and to the last its remarkable aptitude for thriving in wet and marshy soils, where most other stocks would die. Well adapted for heavy, clayey, and

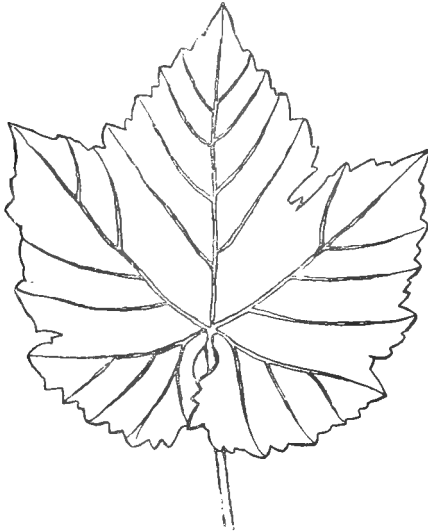

Riparia Glabre Giant.

wet soils. From its last parent it derives a certain degree of susceptibility to *anthracnose* or black spot, and must receive suitable treatment for that disease. A most resisting stock for soils impregnated with saline substances. The cuttings do not strike so easily as those of *V. Riparia*.

#### PERSIMMONS OR KAKI (*Diospyros Kaki*).

This fruit is also called Japanese Persimmon, to differentiate it from the American Persimmon (*D. Virginiana*). It is a pulpy fruit, with few and sometimes no seeds, and a yellow flesh, which in some varieties is streaked with brown. On account of its tap-root the tree requires deep soil, moist and rich. Plant in deeply dug holes. The trees seem to draw much of the nourishment from the subsoil. When not ripe enough the fruit is harsh and flavourless; but when soft and pulpy it is rich, and much liked by many; hence the botanical generic name which literally means "food of the Gods." The Japanese gather the fruit when just ripe, and pack it into cases for a time, when it mellows down and becomes eatable. In China and Japan some are eaten fresh and others dried

like figs, to which it is said they are superior. Some varieties carry their fruit even after the leaves have dropped in the early winter. After a touch of frost the late fruit improves in flavour. The following varieties are described by Professor H. E. Van Deman, Pomologist to the U.S. Department of Agriculture:—

**TANE-NASHI.** *Tane* meaning seeds, and *Nashi* without; the fruit being almost or entirely seedless. Excellent fruit either for eating when ripe, for drying, or for making into preserves. Size medium to large, about 3 inches in both diameters; conical, symmetrical in outline, not furrowed or ribbed; stem cavity deep; skin smooth, reddish orange, with bloom; flesh jelly-like, clear orange yellow, not stringy or streaked.

**HACHIYA.**—Named after a county in the province of Mino. Fruit very large, often three or four inches in diameter, oblong-conic, but tapers rather abruptly at the apex; often quadrangular; dull orange in colour, with dark specks and faint reddish streaks towards the apex. Flesh firm and solid, of a brownish yellow colour, flecked with dull red. Seeds long and slender. Ripens late. Used for drying in Japan.

**YEMON.**—This word is the name of a badge that is worn on the outside of clothing. One of the best; of excellent flavour, and great productiveness. Fruit large, rather flattened, with distinct and deep furrows running into the deep cavity at the stem, and shallow ones meeting at the opposite end, where a slight depression usually occurs; generally quadrangular. Bright orange red colour. Flesh unmixed orange red, very soft; can be eaten off the tree. Often seedless. Flavour sweet when soft, but astringent when hard. Season early, and does not require frost to ripen it.

**DAI-DAI MARU** (Fig. 1).—Fruit medium to large, about three inches in diameter, round shape, with a little depression at the base, and slight cavity at the apex; surface smooth, free from dark specks and cracks. Colour, pale orange; flesh, orange red; soft when fully ripe; seeds plump; rich, sweet flavour.

**HYAKUME** (Fig. 3).—Literally translated "one hundred *mé*," the word *mé* a unit of weight in Japan, and a hundred *mé* being about equal to one pound of our weight. Similar in shape to the Tane-Nashi, but is not seedless. Slightly conical in shape, but depressed and somewhat furrowed at the point; light orange in colour, and not so dark as the other varieties; near the apex a number of marks like pin scratches; flavour excellent; tree a good grower and an abundant bearer; seeds, when present, about twice as long as they are broad.

## THE OLIVE (*Olea Europaea*).

One of the first trees introduced and planted in Western Australia by the early settlers was the olive; and the magnificent specimens now seen at the older established places bear testimony to its adaptability to the conditions prevailing. The olive has, however, never yet been extensively nor systematically cultivated here, on account of the labour difficulty. The tree likes a deep free soil, well drained, where the roots penetrate deeply. It does very well on limestone formation. One kilo of olives contains 7 grammes of potash, 3 of nitrogen, and 1 of phosphoric acid. Green leguminous crops, well manured with potash and phosphates, may be ploughed in at blossoming time. As regards climate, frosty localities are injurious to some kinds. Generally speaking, a climate where the Muscat vine does well suits the olive best, *i.e.*, moist winter and spring months and dry, clear summer.

The olive begins to bear when four to six years old. As in the case of the peach, the fruit is either clingstone or freestone. When ripening it turns from green to purple, reddish brown, bluish, or black, with or without bloom. Even when ripe the fruit is harsh and bitter, with the exception of a few varieties such as the Piru, bearing sweet fruits which may be eaten fresh from the tree. For pickling, this bitterness has to be removed. In size olives differ greatly, from the size of a small grape berry to that of a small plum. In selecting varieties the choice should be directed by the purpose in view—oil or pickles.

If for oil: productiveness, quality of the oil, even ripening of the fruit upon the tree, and hardiness of the tree should guide one's choice.

If for pickling: size of fruit, firmness of flesh when nearing maturity, shape of fruit, quality of the pickled fruit, productiveness and hardiness of the trees should be considered. Oil is also made from pickling olives, either too small or from damaged fruit. Thus may be turned into account what would otherwise be wasted. It is profitable as a by-product of the pickling industry.

Propagation may be done by seedlings, which must, however, be grafted when strong enough. The oily pulp of the olive is injurious to the germination of the seed and should be removed by steeping for a day in 10 per cent. solution of caustic potash and washing the kernel clean. Nurserymen also at times feed the olives to ducks and collect and wash the kernels ejected from the birds. If a few seeds only are planted, they may be slightly cracked by pressing in a vice.

The most common method of propagation, however, is by cuttings, which strike readily and reproduce trees true to kind. Small twigs of recent growth or "tips" are thus struck in sandy loam under glass; in the spring they grow a root system almost as good as a seedling. Stronger wood, or "truncheons," is also used and

struck much like vine cuttings in a nursery; many plant truncheons or lengths of wood about one inch in diameter and a couple of feet long, sawn half through into sections a few inches long. These are laid in shallow trenches with a few inches of loam on top and kept moist. A number of shoots spring from these truncheons, which are, when planting out, sawn completely off into short sections carrying growing wood and roots. In Spain, where olive wood is easy to procure, a common method of planting is to dig a hole and plant a piece of olive wood a couple of inches or so in diameter much as if it is a fencing post; a mound of earth is banked up around the stick and a tile or two agave or aloes leaves are inserted at the base of the mound to serve as a channel into which water is poured in the summer to maintain the ground moist around the stem. In this manner a bunch of shoots soon grow on the top of the green stick which readily takes root, and a tree two or three feet high is obtained in one season, which bears fruit when two or three years old. The olive is best planted in rows wide apart, say, 40 to 60 feet, with intermediate rows of quick growing and shorter lived trees, such as peaches, loquats, Japanese plums, passion fruit, etc.; these being removed when the olives spread out.

Grafting and pruning have been dealt with in a previous chapter.

Olive trees are much neglected as far as cultivation goes; hence the impression that the tree is slow of growth and tardy bearing. They, however, respond to manuring and to cultivation, and whenever necessary to irrigation—preferably few and copious—as readily as most orchard trees do. The olive, like the almond tree, is particularly suitable for planting along drives or boundary fences and also in odd corners and sloping banks, provided the soil be deep and friable. If rocky or underlaid with a hardpan the spot where it is intended to plant may be loosened by the use of explosives, such as lignite.

The olives ripen in the latter part of the autumn; the harvesting being somewhat costly, particularly if the crop is light and the trees high, and amount on an average to 3s. 6d. to 4s. 6d. per cwt.

If for pickling the fruit is picked when just turning—for green olives—or when dark for ripe pickles. In any case it is essential to avoid bruises, and for that purpose baskets lined with hessian are used or buckets with a little water in them. Where the pickling factory is distant haulage in barrels containing water are used.

For oil the harvesting is best done by shaking the branches, also by beating down the ripe fruit, which are collected over sheets spread under the trees. This treatment often reduces the subsequent crops by breaking the bearing shoots. The stray olives are picked by hand; a special ladder, illustrated (page 128) in the chapter on picking fruit, being used for the purpose. At the factory these are put through a winnower to remove dirt, leaves, etc.

Amongst some of the best olives for "oil" are:—

**VERDALE** (Fig. 1).—Ovoid-shaped, early ripening, berry a little flattened at the base and elongated at the top; of a green brown colour when ripe; not very prolific, but giving an oil of a high quality. The tree makes relatively little wood, early and constant bearer, carrying fruit low, enabling the harvesting to be done at less cost; also used for pickling. Can be planted 25 feet apart.

**PICHOLINE** (Fig. 2).—A hardy, rapid-growing variety; good bearer; produces berries of medium size, ripening early, and yielding about 16 per cent. of good oil, but not of a superior quality; better adapted for pickling. Stands frost well.

**BOCQUETIER**.—A favourite French oil producer. When checked by judicious pruning will yield a large quantity of fruit. Grows to a large tree. Plant 40 feet apart.

Of the following four the Principal of the Dookie Agricultural College says: "Where they can be procured, no others should be favoured":—

**MISSION**.—111 olives to the pound, 17.56 per cent. of oil.

**PLEUREUR**.—170 olives to the pound; untested for percentage, but gives high practical test.

**CORREGGIOLO** (syn. Frantoïo).—262 olives to the pound, 21.15 per cent. of oil; oval, medium size, narrow at the stem end, broader towards the point.

**HERBEQUINA**.—144 olives to the pound, 24.80 per cent. of oil.

Other fairly good oil varieties are Boutillano, Pigale, Attica; but where the first four mentioned can be procured, the principal considers no others should be favoured.

*Olive Oil* is found clear and ready made in cells in the pulp of the ripening fruit and also in lesser quantity in the kernel. To obtain it the fruit is crushed and the mash is pressed, when it runs out with the water of vegetation, from which it separates by virtue of its specific gravity, as oil is to water, as 915 is to 1,000.

The fruit is picked when just about to turn, when it has turned violet in colour and also when almost black. At the first two stages the oil is of the best; when made from dead ripe fruit it does not keep so well. The yield averages 15 to 16 lbs. at six years, 50 to 60 lbs. at 10 years, and about 2cwt. at 20 years. A poor crop succeeds a big one unless by judicious pruning, good cultivation, manuring, watering where practicable, and care in picking the growth and productivity of the grove is maintained.

Varieties yielding less than 17 per cent. of recoverable oil, or 38 gallons per ton, are considered poor. Some kinds yield as much as 50 gallons per ton.

The olives that are picked by hand produce the finest oil. Long keeping before crushing causes a fermentation with generation of heat; with lack of scrupulous cleanliness during the opera-

tions of crushing, pressing, and filtering it is the cause of the oil turning rancid and lacking in keeping quality. The picked olives having been cleaned on the winnower, and if necessary washed, as is the case when they are swept from the ground under the trees, they are crushed fresh; when sound and in good order they may be allowed to be spread on the floor for a few days in layers a few inches thick until they can be crushed; during that time they wither and lose a certain amount of their water of vegetation.

The crushing is done over a grooved, circular cement trough by rotating, heavy millstones, which reduce flesh and stones into a mash. Instead of millstones, crushers like those used for grapes are used; they consist of a hopper over two cylinders of cast-iron, fluted, horizontal and turning slowly in opposite directions.

The paste is collected into a tub and put into flat bags or envelopes made of specially woven esparto grass, of rushes, a coarse cotton fabric, or even hessian. In some parts of France it is customary to sprinkle over the paste, before putting into the bags, a small quantity of vinegar, or of a decoction of tannin-bearing bark to coagulate the mucilaginous matter and facilitate the flowing out of the oil. A dozen or more of these flat pulp bags are piled up on the platform of the press, light wooden battens or tinned discs being sandwiched in between to favour the running of the oil when the pressure is applied.

Instead of the pulp bags, a galvanised iron cylinder, reinforced with iron hoops and perforated with holes, may be used; the flowing of the oil from the metal recipient is facilitated by inserting perforated boards or mats of rushes at short intervals throughout the paste; lining with sackcloth inside prevents the pulp being squeezed out. Pressure is brought on gradually, to allow the oil to flow out. The first run is the *virgin oil*. The pressings are collected in tinned receivers and transferred to larger ones when it settles, the lighter oil floating over the dregs is carefully skimmed off with a tin ladle or else with cotton or a sponge. There still remains some oil in the water of vegetation and the dregs; these are collected in bigger reservoirs where in time the oil separates and floats, when it is collected.

When the first crushing is done the press is opened and the compressed mash is broken up; some pour a little boiling water over it to coagulate the albuminoid matters, others prefer, for that purpose, a solution of some mild vegetable acid—citric, acetic, or tannic. Pressure is brought on again and a further quantity of oil is extracted from the squeezed-out liquor.

The clarification of the oil is effected by natural means, *i.e.*, by rest and decantation, or by artificial means, such as filtration and treatment with vegetable acids for fine oils or with mineral acids and alkalis for the common oils. After a few days' rest the oil



frees itself and is more or less clarified. It is generally necessary to transfer it to other receivers and allow it to rest again for a few days. It may then be stored until sold, and during that period it continues to clarify.

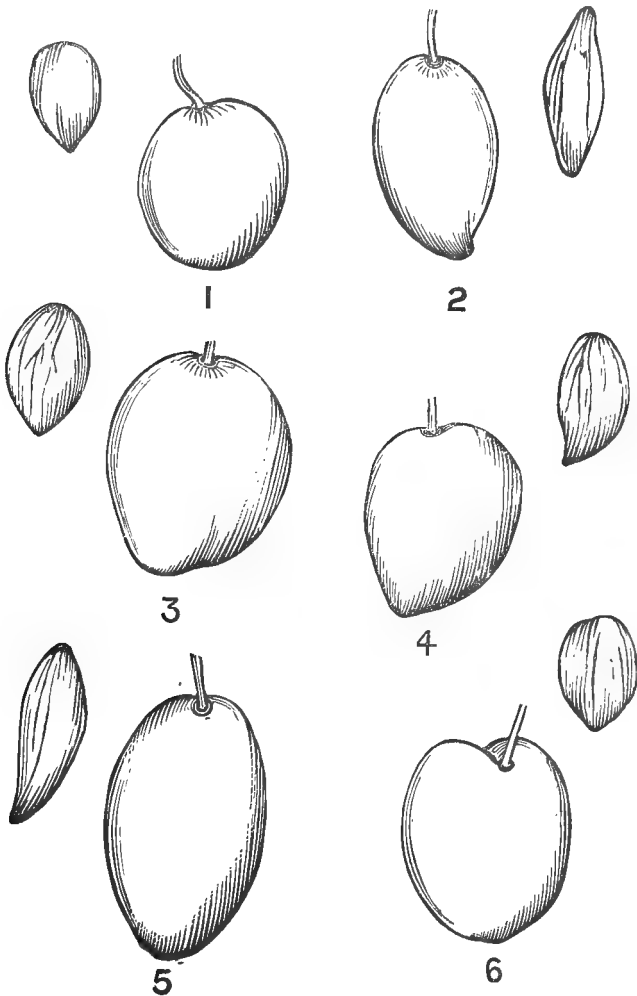

PICKLING OLIVES.

1. Verdale and kernel. 2. Picholine and kernel. 3. Sevillano and kernel.  
4. Gordal and kernel. 5. Pendoulier and kernel. 6. Manzanillo and kernel.

A quicker clarification is obtained by treating the oil with a diluted solution of such vegetable acids as citric, acetic, or tannic,

which act chemically and mechanically upon the foreign matters in the oil and bring about their precipitation.

Filtering offers a quick way of separating the albuminoid matters and other impurities from the oil. The filters consist of horse-hair sieves or wire gauze set in tin funnels. Over the sieve is spread a piece of felt with a layer of cotton wool. Filtering should be done prior to bottling. Of the pressed-out juice, about one-quarter is recovered as olive oil. The proportion of fresh fruit to recoverable oil is in the neighbourhood of six to seven, and of partly dried olives, about five to one of oil.

For pickling, the following is recommended:—

SEVILLANO, syn. *Regalis*, *Pruneau de Catignan*, *l'Espagnole* (Fig. 3).—One of the largest olives grown, viz., 1¾ in. thick. This is the variety exported from Spain as the Queen olive. Round, ovate pit, generally straight, square at the base, pointed at the apex; a clingstone; bluish-black when ripe. Picked for green pickling, and yields a small quantity of a deep yellow oil. Tree small; fruit ripens medium late. 37 olives per lb.; 17.23 oil per cent.

GORDAL, syn. *Hispalensis*, *Oliveo Real* (Fig. 4).—Fruit differs from the Sevillano in being less symmetrical, being larger on one side than the other. Much esteemed for pickles, and also yields a good oil. Tree very large and vigorous, with shiny branches, lance-shaped leaves, dull green above and clear white below. Ripens early; stands cold well. Like Sevillano, requires deep, fertile soil; requires heavy pruning. Very widely grown in Spain.

ASCOLANO, or Olive or Ascoli.—Also a large fruit of the shape and size of a French prune, valuable for green pickles, and, like most olives of that description, better suited for warm districts.

PICHOLINE.—See above.

MISSION.—111 olives per lb.; 17.50 oil per cent.

PENDOULIER, syn. *Oblitza* (Fig. 5).—Fruit large, oval. Tree a good grower, and productive.

MANZANILLA (Fig. 6).—Large, 1 inch long; rounded oval. Ripens early. Fruit much like the Sevillano; grows on long stems. Pulp rich. Readily loses its bitterness when pickled. 72 olives per lb.; 16.90 per cent. Fruit large, of dark colour when ripe.

*Pickled Olives.*—Both green and black or ripe olives are pickled, but they are treated separately. The fruit must be carefully picked or else bruises will show. The treatment consists in neutralising the bitterness and acidity by steeping in a lye solution made up of 2oz. caustic potash to one gallon of water. A float will keep the olives submerged and exclude the light, which has a darkening effect. An addition of salt, 2oz. to the lye, is used if the olives are soft. The fruit is occasionally stirred with the hand. If on cutting an olive with a knife the flesh is seen horny-looking, without a white ring, it is ready, and the lye is run off, generally after eight to twelve

hours soaking, but sometimes longer. Taste will also show whether all the bitterness has been removed. Secondly, the lye is washed off by running it off carefully and replacing it with soft or rain water, which is renewed twice a day until all the lye has been leached out, which takes longer if salt has been used. This takes two or three days. A piece of red litmus paper dipped into the water before salting should not turn blue if all the lye has been removed. Thirdly, salt is then added in the form of a brine containing 6ozs. to the gallon of water, which, after two days, is run off and a stronger brine—8ozs. to the gallon—poured over the olives. After a few days, a stronger brine still, *i.e.*, 12 to 14 oz. to the gallon, is used. Unless the strength of the brine is only gradually increased the olives will shrink and shrivel. Finally, before bottling or casking, a strong brine, strong enough to float an egg is made, boiled, skimmed, and when cool, poured over the olives previously placed in bottles, which are then corked down and sealed. The addition of a little vinegar improves the colour of green olives, while some also like to add a few bay or all-spice leaves.

For pickling "black or ripe" olives, salt is generally sufficient to remove the bitterness which is less pronounced as the fruit ripens. The olives are placed in jars or in barrels, sterilised by steam; they are then mixed with fine salt when they part with the bitter juices. After a few days they are steeped in fresh water for a little while and half dried. Before eating they are dipped in a light brine or in oil. Thus prepared, large quantities are consumed as an article of diet in olive-growing countries in the Mediterranean. Ripe olives in this form are more easily digested and possess a higher nutritive value than green pickled olives.

## NUTS.

These fruit are true seeds only, and are made up of fleshy coverings or pericarp, such as plums, apples, etc. They constitute a highly concentrated form of food, having less water than most fruit, with a higher percentage of protein or albuminoids and of fat.

**SPROUTING SEEDLINGS.**—Nuts are generally sown in seed beds, and subsequently grafted to the kind it is desired to grow.

The pits from natural fruit or seedlings are the most reliable stocks; they germinate easily, make more vigorous growth, and produce longer lived trees.

They should not be allowed to dry after being taken from their covering or from the fruit, and they should without delay be put in sand or layered in the ground, to prevent the germ from drying. If allowed to dry, the pits either die or remain dormant in the ground for a year, and sprout the following season if left undisturbed.

In the cultivated and highly improved fruit, the union of the two halves or valves of the pits is often imperfect and "split." Such

nuts will not readily germinate, and are destroyed by moulds, and rot. In natural seedlings they are more tenacious, and the kernel better retains its vitality. When layering nuts or pits of stone fruit a well-drained spot is chosen; the place is marked with stakes or enclosed within boards, the soil is dug out, and a layer of nuts or stones from five to six inches thick laid down and covered with loose earth. They are allowed to remain until early spring, when the kernels are swollen and some commence to sprout. They are then planted out in nursery rows and carefully cultivated, and when strong enough the seedlings are either budded or grafted.

#### ALMONDS (*Prunus amygdalus*).

Australia is in a great measure dependent on imported almonds for its requirements. Some old hardshell seedlings are seen growing around homesteads and bear a good crop of nuts, but orchardists have been too long dependent for their trees on Californian and oversea kinds of almonds, which, while highly praised in their natural habitat, fall short of expectations when grown under Australian conditions. The same difficulties have been experienced in America until locally-raised seedlings selected among a great number raised for experimental purposes, showed points of superiority which single them out amongst the duffers growing around them.

Experiments show that locally raised seedlings carry and mature fruit where the imported almond fails.

Several experimenters in Western Australia have succeeded in raising such seedlings of great promise which have so far given a good account of their productiveness and their value. Mr. J. P. Lauder, on the Chapman River, and Mr. Sanderson, of Guildford, among others, have brought out seedlings which appear to be superior to the majority of the introduced kinds enumerated in nursery-men's catalogues.

My personal observations of the North-West coast, however, lead me to believe that the cultivation of the almond under irrigation promises to be more remunerative there than in the South-West of this State. The cool winter followed by warm, sunny and dry weather at blooming and setting time, should be more favourable for the bearing trees than the showery, cold, early spring months further south.

The majority of almonds bear two classes of flowers: the female and the male. These issue at some days' interval, and at times so early in the spring, as to fail to set on account of light frost or of defective pollination. Fungoid diseases—Rust and Shothole—by weakening the fruit buds so interfere with the normal setting of the blossoms that unless preventive treatment is applied, the crop is seriously reduced. On this account it is advisable to grow the trees on warm slopes; mix the kinds for a better pollination, and spray and free the trees of fungoid diseases.

The almonds are propagated by budding on seedling bitter almond stocks or on peach stocks. The apricot is condemned as a stock on account of its imperfect union with the scion.

Plant only varieties which are good annual croppers, hull easily, and have a clean, thin, soft shell, with smooth, plump, single kernels, in preference to those with double or triple nuts, which commerce does not seek for. The newer Californian sorts are better in this respect.

An average of 10lbs. of hulled nuts per tree is a very good crop, and 5lbs. a good crop.

For confectionery the kernels of hard shells, which are easily secured by the use of specially devised machinery, are just as profitable as kernels of soft shells, and even more so, as hard shell almonds are often better and more reliable bearers.

Gathering the nuts by hand is tedious work, and can only be practised when the tree is small. The harvesting is generally put off, when half the nuts have burst their hulls; if the tree is then shaken, the nuts are collected on a sheet of canvas, and allowed to remain a few days before being hulled. The hulls having been either naturally or forcibly removed, the nuts are placed in trays and dried in the sun. This requires three or four days. This hulling and shelling, when done on a large scale, is done by machinery, a very small percentage of the nuts being broken in the process. This work is particularly well done on "stick-tights," when the hull and the shell are closely stuck together. When dry, the nuts are bleached by being lightly sprinkled with water and exposed to sulphurous fumes for a few minutes. After the odour of sulphur has dissipated, the nuts are then graded; the broken and inferior ones are shelled and sold as kernels, the sound ones are packed in sacks and marketed.

In the south of France a good proportion of the crop is gathered when quite green and before the skinny covering of the kernel has turned brown at all. At that stage the shell has not yet hardened, and the nut is easily cut with a knife. These nuts sell readily at a good price for *hors-d'oeuvre*.

I.X.L. (Figs. 1, 1A).—Tree a sturdy upright grower; large leaves and nuts, single kernels; hulls easily, and does not require bleaching; shell soft and very suitable for the table; good flavour; a good and regular bearer. One pound of these almonds contains on an average 9oz. kernel and 7oz. shell.

LANGUEDOC (Fig. 2, 2A).—A French almond, known to the trade as soft shell; nut large; not a very regular bearer; kernel  $7\frac{1}{2}$ oz., shell  $8\frac{1}{2}$ oz. to the pound of nut.

NONPAREIL (Figs. 3, 3A).—A weeping habit of growth; smaller foliage than I.X.L.; an abundant and regular bearer; a paper shell nut with almost invariably a single kernel of excellent flavour. A large proportion of kernel to the pound of unshelled nuts, viz., 12oz. kernel and 4oz. shell.

JORDAN (Figs. 4, 4A).—A corruption of the French "Jardin," meaning "garden"; a standard variety; long and slender nut, not strictly hard shell, although harder than soft shells.

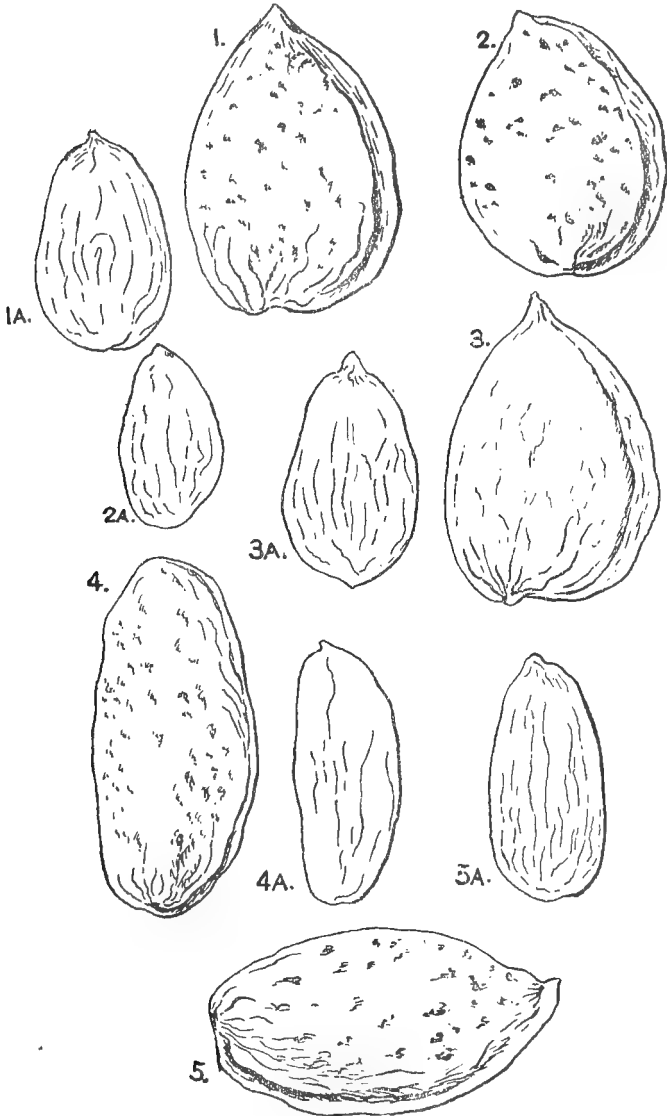

## ALMONDS.

1A, I.X.L. and kernel; 2, 2A, Languedoc and kernel; 3, 3A, Nonparell and kernel; 4, 4A, Jordan and kernel; 5, 5A, Ne-Plus-Ultra and kernel.

LAUDER (Seedlings).—West Australian seedlings raised on the Chapman River.

SANDERSON'S SEEDLING.—Also raised in Western Australia.

NE-PLUS-ULTRA (Figs. 5, 5A).—Like I.X.L. and Nonpariel, a Californian seedling. The three should be planted in close proximity, to favour pollination. Paper shell; nut large and long; hulls freely; single kernel, which is long and slender, resembling the commercial Jordan. A heavy and regular bearer; 10oz. kernel, 6oz. shell to 1lb. of nuts.

#### CHESTNUT (*Castanea* sp.).

Several varieties are grown, of which the European species (*C. vesca*), known as French, Spanish, and Italian chestnut, are more widely known. Another variety, the Japanese chestnut, is also gaining favour. It is a dwarf tree, suited for hedges and copses rather than for independent growth, but yields a nut which is larger than the largest European chestnut, and bears in four or five years from planting. The European chestnuts reach large dimensions, and, being quick growers, would do very well for avenues and shade trees. They require planting widely apart, and do best on free, moist, gravelly soil, beyond the reach of spring frosts. Limestone, clayey soil, and swampy land should be avoided.

Chestnut trees of majestic size grow with great luxuriance in the rich valleys of the Darling Ranges about Jarrahdale, and also in the southern districts about the Vasse. Although not widely planted, they should thrive well in our cooler climates.

The trees are readily grown from seeds, of which the largest and finest are selected. These are stratified in damp sand in the autumn and the winter, and planted, with the sprout up, in nursery lines, two to four inches deep, in the spring. At the end of the first year they are lifted, the tap root is cut off, and the trees either planted out or reset, giving them more room.

Grafting by means of the ordinary cleft graft secures earlier fruiting and fruit of a known character.

The composition of chestnuts is starchy rather than oily, containing 43 per cent, of starch, sugar, dextrin, etc., and about 6 per cent. of oily substance.

Storing chestnuts for market or for home use is generally preceded by scalding in boiling water and stirring with a stick. After 15 or 20 minutes the nuts are spread out and dried. Wormy nuts floating on the surface are removed. The nuts kept in bags or in barrels are then used as required. The meat after this scalding being less horny and hard.

SPANISH.—A sweet European kind, bearing its fruit in burrs. Splendid shade tree.

PARAGON.—Large, sweet, European. Early and abundant bearer.

PARRY'S JAPAN GIANT.—Large leaves, vigorous, upright grower. Nut very large, smooth, dark coloured; one or two nuts only in a burr; the scar covers nearly half the shell.

EARTH NUT, *Arachis hypogea*.

These annual leguminous plants thrive to great perfection in Western Australia. In Spain, Algeria, South America, and India they constitute an important industry. The nuts are graded, sacked, and sold in large quantities for eating, while an enormous amount is crushed in mills, where the oil—of which the nut contains over 40 per cent.—is extracted, and the residue compressed and sold for feeding stock.

The oil, which is largely used for lighting and for soap making, is imported into Australia in large quantities.

The nuts are brought by the shipload from the Levant and from India and treated in the large olive oil mills around Marseilles.

The nuts are first crushed and cold pressed, yielding an almost colourless oil, of pleasant taste and smell, which is used as an adulterant of salad oil. It is easily extracted, does not readily turn rancid and is palatable. The paste is then sprinkled with water and pressed again, cold, the oil being used mostly for lighting. The third oil is next extracted from the steamed paste, and is in great demand for soap making, while the residual cake constitutes excellent food for stock, being palatable, rich in protein and in starchy and sugary matters, apart from the unextracted percentage of oil remaining in the residue.

The climate best suited for the cultivation of earth nuts is one free from frost for about five months. The soil should be free and light and deeply ploughed to permit the easy penetration of the flowering organs, which curve downwards into the ground, where they enlarge and ripen. A gravelly loam with a retentive clay sub-soil suits it well. Lime or marl, if not naturally present, must be added either with the fertilisers used or independently; without lime the nuts will not develop properly, a large proportion being empty shells, called "pops."

Several kinds of earth nuts are grown—notably a white and a red one. They present somewhat the appearance of a large kind of clover. The white nut has a more spreading habit of growth than the red, is said to be more prolific, and is later in coming to maturity; the red is earlier, and yields fewer imperfect pods or "pops." The colour of the skin of the kernel differentiates these two varieties.

The land is prepared by deep ploughing, and the distance between the rows generally set two to three feet apart, and planted two inches deep in ridges, with furrows between if irrigated and on the flat if planted on moist land. When irrigated, water is run along these furrows and the soil is cultivated after each watering until the



vines cover the ground. Selected kernels are used for seeds. These are slightly cracked, and set along the rows at intervals of two feet, two together, and covered about an inch deep. It takes 40 to 50lbs. of earth nuts to plant an acre (two bushels of 22lbs. to 25lbs.). Weeds are kept down and the surface prevented from setting hard. Cultivation ceases when the flowering organs have penetrated the

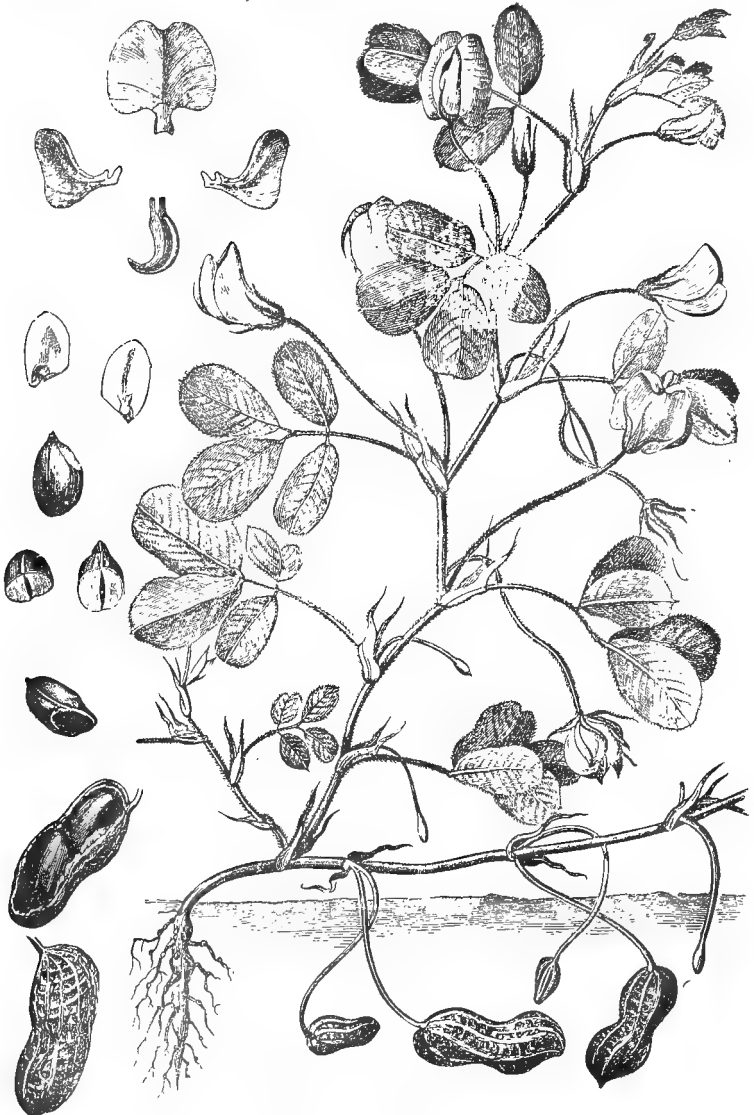

Fea Nut or Earth Nut.

soil and when the vines have spread sufficiently to keep down the weeds.

The crop should be harvested before the first frost (when ripe the tops begin to dry up). For that purpose the tap-roots of the plants are cut deeply with the hoe, or, if the field be large, a plough with the mould board removed and with a "sword" or long-cutting flange welded to the point is run down each side of the row. The plough is run deep enough to cut the tap-root without disturbing the pods. Some dig the plant up by the aid of a close-pronged fork, and the root portion, with the pods adhering, is exposed to the sun to dry. When wilted, the earth is shaken off the roots of the plants, which are loosely stacked round a pole six or seven feet high, in small stacks which will not heat. After a few weeks the nuts may be picked off the vines and stored in a dry and well-aired place, prior to being screened and sorted for marketing. Where the dry vines are not consumed by stock they should be returned to the ground, to be ploughed in.

The green and unripe pods are less oily than the ripe ones, and more easily digested; they are pleasant eating when roasted.

An average yield is about 10cwt. per acre, or about 50 bushels, weighing 22 to 30lbs. according to the plumpness of the kernel. The wholesale market value runs from 2½d. to 3d. per lb.

At the Hamel Experimental Station Mr. Berthoud grew several kinds, viz., Tanjore, Barbadoes, Mauritius, and White Valencia, which all did well, but would, I have no doubt, have yielded better still if grown on a moist marl or in calcareous soil in the warmer portions of the State. At Port Darwin and in the Kimberleys pea nuts do well; under moderately favourable conditions crops of 50 bushels are obtained. In Queensland the average yield of the crop is 1,675lbs. (56 bushels), valued at £21 per acre.

#### THE FILBERT AND COB-NUTS (*Corylus Avellana*).

These nuts are improved varieties of the common hazel nut of the woods of Europe. These small nuts have not been sufficiently

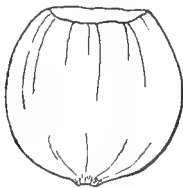

Cob.

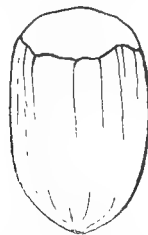

Filbert.

grown yet in Western Australia to ascertain what measure of success their cultivation promises. In California, which in so many respects

may be compared to Western Australia, their bearing has not been satisfactory, except in the cooler and moister situations. It would seem, therefore, that the localities best suited to the filbert and cob-nut in this State would be the moister and cooler Southern districts. The soil must not be water-logged, but moist. The plants may be set at distances 10 to 14 feet apart. Propagation from nuts does not produce reliable varieties, and for that reason layers made in the spring are preferred, shoots two or three years old being simply notched with the knife, and pegged into the soil two or three inches. When planted out the year after, the base buds are removed, as is done in the case of the gooseberry, so as to get a clean stem. They are not allowed to sucker, but are grown in the form of low bushes, branching out about two feet from the ground.

A distinction is made between the cob and the filbert. The cob-nuts are rounder, and are not covered; while the filberts (full beards) are entirely covered with long husks.

#### THE WALNUT (*Juglans regia*).

This nut, incorrectly called "English walnut" and "Madeira nut"; introduced from Persia. It forms a handsome spreading tree, bearing crops of large and excellent nuts enclosed in a simple husk. In the fertile Lower Blackwood and Warren districts of the South-West, walnuts grow to great perfection, and its more extensive cultivation deserves in this State more attention than it has hitherto received. Fine young trees from the Warren nuts are grown at the Forestry Department State Nursery at Hamel. The nuts are stratified, and when they begin to germinate are planted in nursery rows, where they are generally left for three years before planting out. There they grow in size while the roots also attain good development. When planting out, the tap-root is severed with the spade and the stem cut back to four or five feet, irrespective of branches. The trees should be planted about 40 feet apart on deep free loam. They begin to bear at the age of six to eight years, and continue bearing regular and increasing crops of nuts for a great number of years after. When planting, soft-shell, heavy nuts alone should be selected. As the plantation is so wide apart, and as the land suitable for the walnut trees must be deep and moist, it is found profitable for the first few years to grow root and other crops between the rows, or to interplant smaller, earlier fruiting trees, which, after a period of ten or twelve years, can be removed to make room for the larger walnuts.

The same tree bears both male or staminate buds, which develop into "catkins," and pistillate ones, which are terminal, and produce the nuts. These are gathered from the ground as they drop off the trees, or the operation may be hastened by jarring the branches lightly. After gathering, the nuts are exposed to the sun

for a few days, until the husks are dry enough to be torn off. The shells may be bleached as are almonds, but this often injures the flavour of the kernel. An average yield would be 40lb. of nuts for a tree 10 years old, and 1cwt. for trees in full bearing.

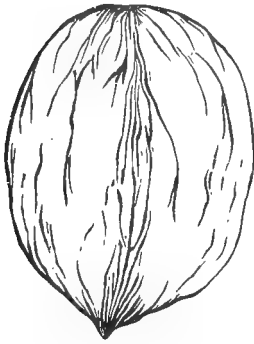

1

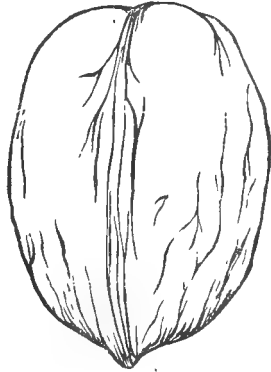

2

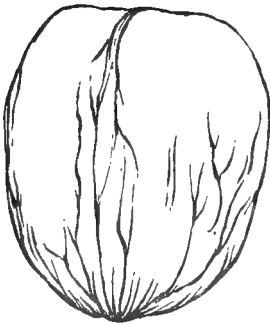

3

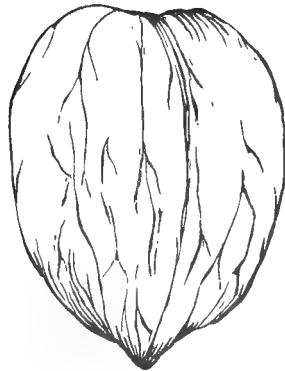

4

Some of the best French varieties are:—

ENGLISH WALNUT of commerce—productive.

CHABERTE.—Small fruit; hardy. Chiefly used for extracting oil.

SANTA BARBARA.—A California seedling from a French variety. Soft shell; bears early and annually; not as strong a grower as other walnuts; its being so prolific retards its growth.

FERTILIS.—Dwarf; prolific. Bears well; has quite a small bush at the Blackwood Nurseries; not such a large tree as the English Walnut.

PROPARTURIANS (Fig. 1).—As its name implies, an early bearer; of dwarf habit and good quality.

FRANQUETTE (Fig. 2).—A large elongate nut of excellent quality. Buds out late.

MAYETTE (Fig. 3).—Round nut, large, full-fleshed; late in budding out in the spring, and for that reason suitable for frosty places.

PARISIENNE (Fig. 4).—Nuts large, a little elongate, even outline; excellent quality. Tree blooms late.

### SMALL FRUITS.

The cultivation of small fruits as a distinctive feature of horticultural enterprise becomes more prominent every day. As large holdings are cut up into smaller ones, and as settlement becomes denser in close proximity to larger centres of population, a desire is shown by many to utilise to its full capacity small patches of moist and fertile land. For this purpose, small fruit and berry culture should command the attention it deserves. A great choice offers to the grower, as there is hardly a locality where, provided care and attention be bestowed upon it, some kind of small fruit bush cannot be grown.

#### BLACKBERRY (*Rubus*, Bramble).

Belongs to the same family as the raspberry, it includes the dewberry, which, however, is not superior to the blackberry, and also the wineberry, and the Loganberry. The fruit is a collective mass of drupes attached to a receptacle, which falls off whole and does not separate as in the raspberry. The berries are small, ovate, brown or black; some are yellowish white.

LOGANBERRY.—A vigorous grower, handsome foliage; large red berries, resembling raspberries before they are ripe. An American hybrid between black and raspberry. Flavour is rich when cooked. When used for dessert, fruit needs to be fully ripe.

All species of the Bramble family adapt themselves to a great variety of soils and climate; some, if overlooked, spread over the land and become a pest; cuttings strike root readily. The trailing kinds require the support of a fence to keep them up, and have been ground round orchards and paddocks: they, however, harbour vermin and birds. These berries are more suited to the cooler and moister S.W. districts than to the drier inland ones. Among the sorts which have done well in Australia are: Himalayas, Wilson's Early, and Lawton's (New Rochelle).

CAPE GOOSEBERRY (*Physalis peruviana*).

A Peruvian fruit introduced into Australia *via* the Cape of Good Hope: hence its name. The name "gooseberry" is misleading, as it is not a gooseberry at all.

Three species of this genus are cultivated for fruit, known under the names Alkekenge or Cape Gooseberry, Husk tomato, Strawberry tomato, Winter or Ground cherry. The plant is a branching perennial herb, belonging to the Solanaceæ, which includes such well-known plants as the tomato, tobacco, etc.; its roots are fibrous and surface feeders; by deep manuring deeper root growth is encouraged. The plant is somewhat susceptible to cold, therefore does best in localities free from frost. It likes a good subsoil, rich in available potash, and this is probably the reason why it does so well on newly burnt-off scrub, the ashes of which provide the required potash. The fruit consists in a berry of the size of a cherry, enclosed in an enlarged and persistent calyx which forms a bladder-like envelope. They are sweet and pleasant, and are considerably used for stewing or for preserves, and also for eating.

The seeds are sown in the spring, and will not endure much frost, and for that reason are planted as soon as the warm weather sets in—August. They are sown in seed beds, like tomatoes, and then transplanted a month or two after and set 8 x 4 feet apart. They are easily propagated from off-shoots in the autumn.

In the autumn cut right back, manure in the early spring, and fresh growth will come up. Picking is a tedious and costly process, the price paid being about 1½d. a lb., a man picking about 40lbs. in one day. This is done when the calyx is seen to dry up; the fruit is also often allowed to fall to the ground and then picked up.

THE CURRANT (*Ribes*).

Like the Gooseberry, belongs to the natural order Grossulacæ and to the genus *Ribes*, of which two species, viz., *R. nigrum* is the parent of the Black Currant and *R. rubrum* that of the Red and of the White Currant. The currants are indigenous of Northern Europe.

Low, deciduous shrubs, with smooth stems; leaves variable, and not unlike a vine leaf in outlines; more or less lobed; flowers small, yellow, crimson or white.

The English name Currant is derived from Corinth on account of their resemblance with the Zante Grape, which was formerly almost entirely imported from Corinth.

Propagation by cutting when the wood is ripe is generally resorted to. The buds, except the topmost two, which are above the ground, are cut off before setting in order to check the suckering habit of the plant. The soil must be heavy, rather than light and sandy, and must also be fertile and well manured, the plant being a gross feeder.

The white varieties are the mildest flavoured, and, therefore, better for eating when used fresh from the bush. The red are preferable for jellies, etc., on account of their beautiful colour; many of them possess a musky taste. Currants may be planted 5ft. x 5ft. or 6ft. x 4ft. apart.

**BLACK NAPLES.**—One of the largest and best black currants; has a musky flavour. A vigorous grower, bears profusely after a few years.

**LEE'S PROLIFIC.**—Very similar in quality to the Black Naples, but the plants are more productive.

**VERSAILLES.**—Dark red, not so acid as the cherry, which it resembles. Fruit of the largest size. Plant a coarse grower, productive and excellent for marketing purposes. The shoots are apt to break off at the base. Best trained supported.

**WHITE DUTCH.**—A vigorous, upright grower; productive; very large and sweet berries, yellowish white, transparent with white veins; good for dessert.

#### GOOSEBERRIES (*Ribes grossularia*).

Low, deciduous shrubs, stems mostly thorny at the base of the leaf-stalks; in some the thorns are scattered. Fruit: one-celled berry, produced in small clusters, smooth or prickly.

They are strongly acid fruits, that come early in the season, and in the cooler and high level localities should be grown largely for family use. In such localities any good soil, well drained, well cultivated, and manured will grow good crops of gooseberries. They respond well to liberal applications of potash. In Europe this is one of the popular berries, and small fruit-growers figure on obtaining greater profit from the gooseberry crop than from any other shrub fruit. They require annual pruning, mulching, and some attention.

The bushes may be set in rows 6ft. apart or 1,200 to the acre. Gooseberry culture has not, so far, attained the importance in Australia which is devoted to it in England, mainly on account of the thorny nature of the bushes. By dint of persevering attention, however, some varieties of spineless gooseberries have been obtained and established, the colours of which range from rose to almost black.

Layering is a sure and quick method of propagating the gooseberry; suckers are rejected on account of the tendency to produce more suckers; cuttings from well-ripened, vigorous growths are, of all the methods of propagating this bush, the method most generally adopted; all buds and prickles are removed for a few inches from the lower end.

The best method of harvesting the gooseberry is to pull the berries from the bushes by stripping with a hard-gloved hand and blowing off what leaves may have also come off when pulling.

at their best for two or three seasons; after this they become less productive and more subject to leaf-diseases and to attacks by insect pests. For this reason it is advisable to have fresh beds made every year, the cold beds being rooted out and left fallow. A regular output is thus secured and pests more easily kept in check.

**CLASSIFICATION OF THE STRAWBERRY.**—The modern cultivated strawberries are derived from four prototypes, two of European and two of American sources. Those improved varieties are, however, widely different from their originators, but they, nevertheless, retain certain characteristics which are essentially their own. By means of hybridisation or pollination, many of the choicest berries have issued, and which combine some of the most prominent features it is sought to develop.



Queen of Four  
Seasons.

**FRAGARIA VESCA.**—Alpine or Wild Wood Strawberry, of which the “Queen of Four Seasons” is one of the most prolific and best. Seeds superficial, on the conical or hemispherical fruiting receptacle (not sunk in a cavity). Flower stalks longer than the leaves, erect, hairy, hairs closely pressed upward. Fruit drooping, conical or globular. Leaves thin, pale green, upper surface uneven. Slightly wavy, unlike those larger strawberries; the result of artificial cultivation. Easily propagated from seeds; very hardy; bearing season protracted. One section of this species is the Bush Alpine or Green Strawberry (*F. collina*), whose only distinct character is in its fruit, which is greenish brown when ripe.

**FRAGARIA ELATIOR.**—Hautbois strawberry, a native of Central Europe. Larger, more erect, and are of longer appearance than the Alpine, often shy bearers, and amongst other peculiarities possess a distinct musky flavour. “Belle Bordelaise” is one of this type. Calyx reflexed, seeds superficial. Flower stalks longer than the leaves, erect. Fruit round or oblate, usually drooping, but sometimes erect, possessing a musky flavour. Hairs on both leaf and flowers. Stalks long, widely spreading, somewhat reflexed. Leaves larger than *F. vesca* and more or less hairy, giving them a rough appearance.

**FRAGARIA VIRGINIANA.**—The Virginian strawberry, and the parent of the greater number of the improved strawberries in cultivation. Seeds imbedded in the deeply-pitted receptacle. Fruit roundish, ovoid to conical, highly perfumed. Flower stalk shorter than the leaves, hairy. Hairs spreading, more or less erect. Leaves obovate, wedge form, variable, coarsely serrate, usually dark green; upper surface smooth, often shining.



**FRAGARIA CHILENSIS OR GRANDIFLORA.**—The Chilean strawberry, also a native of America, from Oregon to Chili. Calyx erect, slightly spreading, seeds set in a shallow depression. Flowers larger than in other species. Fruit sweet, perfumed, firm. Flower stalks shorter than the leaves. When first introduced, it did not find favour, as the blossoms are not self-fertile. This defect has been got over by crossing with the Virginian strawberry.

**BOTANICAL STRUCTURE.**—The strawberry is described as a genus of perennial herb, belonging to the general order *Rosaceae*. It has trifoliated leaves, flat or reflexed, creeping *stolons* or runners, flowers white or yellow. The petals of the flowers are disposed around the more or less enlarged receptacles of the flower stalk. The strawberry is not a fruit in the true sense of the word, but an exaggerated fleshy receptacle of the flower stalk, in which are embedded a number of small, hard, seed-like bodies, which are the true fruits. As the swollen, fleshy receptacles grow in size and mature they become coloured, juicy, and flavoured. In a strictly botanical sense, therefore, the strawberries are neither berries nor fruit any more than turnips or potatoes are roots.

Naturally the strawberry flower possesses *stamens* or male organs and *pistils* or female organs. It is, therefore, perfect, as both these organs are necessary for the production of fruit. This is so in the wild state. Under the influence of cultivation, however, or when transplanted amid surroundings which are foreign to its primitive habitat, the strawberry, like a great many other plants, may become subject to structural alterations which deeply modify its sexuality.

The figures show two types of flowers: the "bi-sexual" or self-fertile flowers and the "pistillate" or imperfect flower.

Both possess petals; in the perfect or bi-sexual blossom, and around the convex core which, when developed, constitutes the strawberry are two sets of organs, viz.: the female organs or *pistils* (p) in the centre, and around them the male organs or *stamens* (s). In perfect blossoms, these *stamens* are equal in length, or longer than the *pistils*, and they are then able, when the *anthers* or seed-sacs which surmount each of them, are ready to burst, to shed the grains of pollen on the *stigma* or receptive end of the *pistil*, a tubular organ down which they travel to the ovary, where pollination or impregnation takes place.

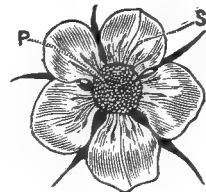

Bi-sexual.

The imperfect flowers on the other hand, or "Pistillate," only possess the female organ (p), the *stamens* being either absent or diminutive in size, or else reflexed. Such flower, to produce fruit,

must be fertilised by a flower possessing *stamens*. It follows in practice that whenever pistillate varieties are planted, it is necessary to intermix with them bi-sexual or hermaphrodite varieties.

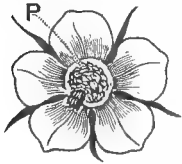

Pistillate.

Such intermarriage must be made with discernment, and it is imperative that the sorts to be mated should blossom concurrently; the period of blossoming of the polleniser or perfect flowering plant should, moreover, be more protracted than that of the "pistillate," so as to fertilise all the blossoms throughout the blossoming period.

It is convenient in that case that the sorts brought together, instead of being intermixed haphazard, should be planted in alternate rows, one row of perfect or bi-sexual strawberries to three rows of "pistillate." The pollen in that case is conveyed from blossom to blossom by the agency of wind, insects, and notably bees, which in every well conducted strawberry garden should receive every care and attention.

Although it is recommended that the amateur should do well to entirely avoid pistillates, the commercial grower, on the other hand, will find them as a rule, under proper treatment, more prolific, hardier, and better packers than the majority of strawberries: *ex Haverland*.

Nor are all imperfect strawberries exclusively pistillated; amongst them, and especially in the *Hautbois* and the *Chilian* strawberries, male organs only are found on separate plants, as well as female organs on others, and the former are strictly "staminate." Either of the two if left alone would be barren. Occasionally even these species produce perfect flowers, and it is by propagating such plants by runners that self-prolific stock have been raised. When the *Chilian* strawberries were first introduced into Europe, they found little or no favour, all the plants introduced being found to possess female organs only, and it was only after their cultural peculiarities became better known that they were reinstated and attained to the position they now occupy in the estimation of professional growers.

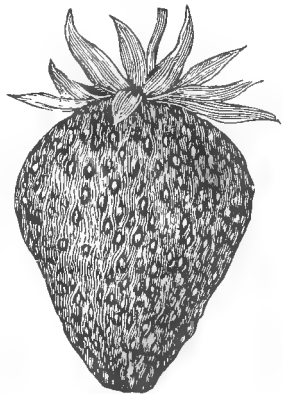

*Haverland*.

Another peculiarity with regard to some of these varieties is that the male plants are generally more numerous in runners than

the female, and grow to vigorous, healthy plants, which tempt the growers; their selection will, however, only lead to so many barren plants being planted.

The conclusion growers should draw from these notes is that although pistillate sorts are highly profitable, they should not be planted alone, but other sorts with perfect flowering organs should be planted amongst them.

*Propagation.*—Strawberries are propagated from seeds, runners, and divisions of the roots. Propagation by seeds is only resorted to for raising new varieties or crosses.

“Runners” are the most common way of propagating strawberries. To ensure their rooting, the surface of the soil should be kept loose and open. Mr. G. Whittington, once of the Orchard Inspection Staff of the Department of Agriculture, thus expresses the method of preserving strong suckers: “Starting to make a fresh plantation, the first three runners shooting from three-year-old stock should be laid down between the rows, and small pieces of wood placed upon them to keep them in position. If the soil is loose and moist, the young plant will soon take root. As soon as the young plant has developed a few leaves, the runners proceeding from it should be pinched off and all other runners separated from the parent plant. At the end of the season the young plants are severed from the parents, taken up and planted out. Strong plants are thus obtained.” Root division is seldom employed except with the Bush Alpine Strawberries, which produce few or no runners. In the early spring take up the stools and divide them, leaving only one crown to the plant. If the old root is very long, cut off the lower end.

*Soil and Location.*—Strawberries adapt themselves to a wide range of soil and location. Too much sand or too much clay should be avoided. Like the other small fruits, the strawberry needs a rich, well-drained, and moist soil. In Western Australia the soil which, as yet, has been found best adapted to the cultivation of the greater number of varieties is the soil which, as on the slopes of the Darling Ranges and the undulating country of the lower plain below, supports in its natural state spear wood thickets and red gum with bracken. Such a soil consists of a deep light loam, warm in colour, well drained and generally moist, overlying a stiffer subsoil at a depth of 18 to 24 inches; of the various species of strawberries the wild wood strawberry (*F. vesca*) and the Hautbois (*F. elatior*) do well on light sandy loams. Calcareous soil of a drier nature suits the Bush Alpine (*F. collina*), a section of *F. vesca*. A rich clayey loam, moist, but well drained, is better suited to *F. virginiana*, and most of the large fruit strawberries. A stiff heavy clay and soil that is liable to become very dry in a short period is unsuitable, and should be avoided; on such soils once the growth of the plants

is checked the crop likewise suffers and is never again a remunerative one.

As a rule, even the same sorts are influenced by variations in the soil and locations. Thus, all things being equal, a strawberry will ripen earlier on a warm sunny slope in light loam than on heavier and moister flats, where on the other hand, the crop, if later, is generally a heavier one. The practical deduction to be drawn from these facts is that the experienced growers are careful, in order to lengthen the season, to place early sorts on a warm, sunny slope, on light loam, and the later sorts on heavy moist flats. Some varieties besides, which show a healthy growth on high, well-drained ground and slopes, are badly affected by leaf blight when struck in damp, hollow ground, and conversely, by moving some of the choicer and more delicate varieties, too blighted to be profitable, from low, damp ground up to more healthy locations, they speedily become more fruitful and more resistant to blight.

*Preparing the Soil.*—Although the land need not be virgin land, it is essential that the plot should be new; that is to say, that it should not have been under strawberry culture before, or for many years previously. Strawberries, indeed, are gross feeders, and abstract from the ground large quantities of fertilising elements, the depletion of which makes the ground unsuitable for that crop after a period of a few years. Old ground, besides, gets foul with parasitic insects and fungi, which prey on the crop. The simplest way of getting rid of such pests is by a system of starvation, which is attained by refraining to plant strawberry after strawberry on the same ground. The ground should be prepared in the spring and laid fallow for the summer preceding planting. If only a small plot, it can be broken up with the spade or the fork to a depth of 12 to 15 inches. If a larger field, two ploughs, one following in the wake of the other with its mould board taken off, should be made to break up the land to a depth of at least 14 inches.

Several harrowings following this deep ploughing reduce the ground to a state of fine tilth, sweetening it by favouring the atmospheric action upon its mass. This clean cultivation also frees the ground of a great many troublesome weeds and of such destructive underground insects as the wire worms, the white grubs of the cockchafer, and other insects that cause injury to the root system of the plant. Besides, the deeper the ground is worked up the better able it will be to absorb and retain moisture, and the greater mass will there be through which the roots will penetrate in search of food and moisture.

When the time of planting comes—about the end of March—the requisite manure is spread over the ground, which is ploughed again to a depth of 6 to 8 inches, and gathered into lands, narrow if the spot is wet, broader if dry; it is then harrowed, and if still lumpy, lightly rolled down,

*Manuring.*—The strawberry is a gross feeder, and the more liberal the grower is in feeding it, the more prolific it proves itself to be. The crop is, moreover, a perennial one, that is to say, when establishing a strawberry bed we must store, at the same time, into the ground a stock of fertilisers which will supply all the requirements of the plants for at least three seasons. Nor must the food be stinted to them, but it should be given in plenty and under an easily assimilable form.

These fertilisers should not be buried too deep either, as the strawberry feeds in 15 to 18 inches of soil. After the deep fallowing, but before the light ploughing which precedes planting out, the manure is placed on the ground.

If well-rotted stable manure is procurable, nothing is better; manure which is not tainted by sawdust litter, and which is procured from stables where the animals are well fed, is the best. Thirty loads to the acre is by no means an excessive dressing; and as the composition of the manure varies according to the class of animals kept, their food, and the way it is secured, it is always advisable to supplement its richness by a further dressing of such chemical fertilisers as kainit or muriate of potash, and of superphosphate of lime, in the proportions of 3cwt. of kainit or 1cwt. of muriate of potash and 2cwt. of superphosphate. The stable manure is evenly scattered first, and the chemical fertilisers broadcast afterwards, and the land ploughed to a depth of 6 to 7 inches.

The main objection of stable manure, however, is that it generally conveys seeds of troublesome weeds; its haulage is, moreover, costly, and it is not, besides, always possible to get it in sufficient quantity. For these reasons some growers prefer chemical fertilisers at the rate of either, for fairly good land, 5cwts. to 7cwts. Thomas' phosphate or superphosphate and same quantity kainit (or one-third the amount of muriate of potash, containing 50 per cent. of potash). For poor, hungry land, 8cwts. to 10cwts. each Thomas' phosphate or super and of kainit. The mixture is prepared on a floor, or a tarpaulin, by first sifting through a wire screen with  $\frac{1}{8}$ in. meshes, and mixing thoroughly with shovels. One-half of this amount applied broadcast is used when giving the last working to land before planting, and the other half sown between the rows during the first season. Just before planting a light dressing of  $\frac{1}{2}$ cwt. of sulphate of ammonia or of nitrate of soda is given along the rows, and also early the second spring, just as the plants are moving from their dormant state, another similar application will stimulate a vigorous growth and an abundant setting. Should an abundance of unleached wood ashes be procurable it would form an ideal fertiliser, as it contains both potash and phosphate. A dressing of 60 to 80 bushels to the acre broadcast would be a liberal one. Although it contains a good deal of potash the strawberry plant is

not beneficially affected by the direct application of potash sorts alone; these are better applied in conjunction with other fertilisers.

*Transplanting.*—After thorough cultivation and manuring, the land should be made smooth by rolling, which also consolidates it.

The time for transplanting having arrived, at the beginning of the rainy season, the plants should be got together. In our climate April will be found a good time; a small crop may then be expected in the spring. Strawberry plants will strike at any time, provided the ground is moist and warm, but autumn planting is found more profitable. If not planted till the spring, all the fruit buds should be removed as they appear, otherwise the plants become feeble and die. Should a large plot be planted, it is advisable to commence with the early sorts and proceed with the latter varieties.

The lines for horse cultivation should be at intervals of 3ft. or 4ft.; for hand cultivation 2ft. will be found enough. In either case the distance along the rows should be from 12in. to 18in.; this the grower will regulate as he becomes familiar with the habits of growth of the varieties he plants. For horse cultivation the lines must not only be well stretched, but the plants should all be set on the same side of the line, so that as the implements run along the rows the soil is stirred at an even distance from the plants all along the drill.

The following are the number of plants to the acre at the distances mentioned:—

2ft. x 1ft.	..	21,780		3ft. x 1ft. 6in.	..	9,658
2ft. x 1ft. 6in.	..	14,520		4ft. x 1ft.	..	10,900
2ft. x 2ft.	..	10,900		4ft. x 1ft. 3in.	..	8,712
3ft. x 1ft.	..	14,520		4ft. x 1ft. 6in.	..	7,260

It is often the practice, however, to plant strawberries amongst the trees in young orchards, and in that case ample room should be left between the row nearest to the trees and the trees themselves—4ft. to 5ft. at least; this would reduce the number of strawberry plants to the acre very considerably. Growing strawberries in a young orchard, under such conditions must be, if the plantation has been well looked after, beneficial to the trees, as the ground is, after two or three years, left in a high state of fertility and tilth, which cannot but be conducive to the growth of the trees.

If the beginner has not raised his plants himself, he should procure them from a careful grower, and he should be particularly careful that the parent plants are strong, fruitful, free from leaf blight and other pests; plants affected by disease are dear at a gift. The rooted runners of the previous year's growth having been lifted and bunched up in convenient handfuls, it is important that their roots are not exposed to the desiccating action of the sun and wind. Some place them over the moist earth with a wet bag thrown over them; others, after trimming off the dead leaves and young runners and shortening the roots one-third, place them in buckets with an

inch or so of water; they will then keep for a day or two. A little quantity of lime or wood ashes in the water would kill any possible slugs which might have secreted themselves amongst the roots of the young plants, and when planting a garden free from such pests every care should be taken against its introduction by means of plants, manures, or packages.

This planting is done either by means of special tools or almost as readily by using either a spade or a spading fork, but whatever the method of setting is followed, it is important that the plants be set at the correct depth; that is to say, not too shallow nor too deep, as in the one case they would perish from desiccation, and in the other through suffocation in the earth; the right way of setting the young plants is with the crown level with the ground, the roots spread out, and never stuck in gathered up in a bunch; in any case, the earth should be well set and pressed firmly around the roots. Plants of even strength alone should be planted together, or else the fruit crops, which generally sets in the second year after planting, is otherwise uneven.

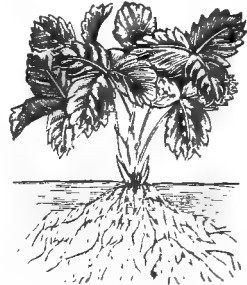

Correctly Set.

The illustrations from Bulletin No. 32 of the Georgia Experiment Station show clearly how to do and how not to do the planting.



Too deep.

If the weather be too dry at the time of planting it is better to suspend this work until the ground is in a better condition. Small plots, however, may be planted even then, provided this is done in the evening when the sun is low, and one pint or so of water is given to each plant. The next day break the crust to check evaporation, and if the weather continues dry, water two or three times the first week, then once a week until the rain comes.

*Cultivation.*—Careful cultivation, following up careful selection of plants, set into equally carefully prepared soil, is the third element of success of a strawberry plantation. If possible, do not let a single weed go to seed the first season, and the result will be apparent on the crop the following year.

Hoeing should be done whenever a crust forms, a week or two after planting; where horse cultivation is used the hoe should be set shallow—a Planet Junior is excellent for that work—while for a hand hoe, a thin steel tool with both narrow and wide blades, is very convenient—so as not to disturb the young roots. Air and

moisture thus freely penetrate the ground, and weeds will be checked. Hand hoeing alone should, however, be used on the ground around the plants. About that time—the second or third hoeing—a slight dressing of sulphate of ammonia or of nitrate of soda,  $\frac{1}{4}$  of a cwt. or a little more, is used with advantage along the rows; this dressing will greatly stimulate the growth of the bushes, which will then begin to show their energy by throwing out runners; these should be treated as weeds the first one or two hoeings, so as to get the plant well established before making any new plants. Cultivation should almost cease from blooming time until fruit is harvested. Weeds and grass gain a foothold during that time; the larger weeds are pulled up by the roots, the ground also sets hard under the tread of the pickers and from that cause, as well as from the gradual exhaustion of the soil by continuous cropping and also owing to the spread of pests and parasites, a plot ceases to be very profitable after three or four years. After the season's growth and at the approach of the wet weather in winter, the last working is given to the land; growers in moist localities set their Planet Jr. behind with left and right mould boards, which gather the soil from the plants and make a ridge in the centre, leaving the plants standing in rows of unploughed ground 9 or 10 inches wide. This allows the water to run off, and, later on, when the ground is worked afresh, these ridges are levelled down by the implements, and the soil is made smooth and mellow.

*Mulching.*—Two or three months after autumn planting, and before blossoming, it is advisable to coat the ground with some sort of mulching two inches thick. Clean straw or grass, rushes, pine needles, or some other such like material may be used for the purpose. Stable manure, owing to the ammonia it gives off, and which rots the berries, or makes them too soft and tender to travel, is not to be recommended; it also conveys weeds and many insect enemies. Nor is tan from tanneries, which favours the growth of moulds in the ground, desirable material, as these moulds smother and destroy the roots. Mulching, besides answering the purpose of keeping the fruit free from grit and dirt, thereby adding to its marketable value, also checks weeds, maintains the surface of the ground moist and porous, and adds a large amount of vegetable matter to the soil when ploughed in. In horse cultivation, and where the rows are well apart, it is better to mulch around the plants, leaving the centre of the rows bare, which enables cultivation to proceed whenever required. Any mulch that packs closely will do more harm than good.

*Pruning.*—The pruning of strawberry plants is of the simplest. First, when planting, as previously mentioned, all dead and withered leaves are excised and the roots shortened to one-third of their length; then, at the time of the first two hoeings, all runners are pulled off and all blossoms from autumn-planted strawberries picked



until the spring, while it is advisable to pick them all through the first season from strawberries planted in the spring. The necessity of cutting the first runners off is obvious, as, unless this is done, the plants will be weakened and will not bear such a heavy crop of berries. Advantage is thus taken of turning the energies of the plant, always bent on reproducing itself, in two directions, from throwing runners and making new plants into producing fruit-buds in abundance, which eventually will mature into a profitable crop. Once the plantation is well established, runners are only permitted in such cases as are required for propagating purposes. At the close of the growing season, old leaves are best trimmed off so as to minimise the spread of the leaf blight and check the harbouring of insects.

*Irrigation and Drainage.*—Although it is admitted by all experienced growers that irrigation lengthens the strawberry season, and that a command of water in a dry spring is of great value and often turns into a bountiful crop one which would otherwise have been hopelessly shortened at a critical period of its growth, yet it is also recognised that irrigation presents serious objections.

It is generally costly when undertaken on a large scale; it makes the ground boggy at the time when cultivation and picking should be actively pursued, it causes a considerable amount of decay of the berries. Good strawberry land, well cultivated, should not, if the plants be mulched, need irrigation.

Deep underground drainage, likewise, with the object of turning unsuitable ground into soil fit for strawberry culture, generally involves growers in an expenditure of time and money which is seldom compensated by an adequate increase of crop. Better not attempt growing strawberries on dry, stiff, or marshy ground than to attempt to remedy its natural defects by methods involving any considerable cost.

*Marketing.*—Morning and evening are the best time for picking. The fruit, picked when fully coloured and with the stalk on, is graded as picked and placed in light wooden punnets lined with vine leaves. The punnets are then placed in rows in crates, and in this way they are easily conveyed to market and distributed without further handling of the fruit.

Little damage is caused by birds, but slugs and snails, where they occur, prove a troublesome pest.

**POINTS OF A GOOD STRAWBERRY.**—Mr. F. L. Jansen, in a comprehensive paper on the strawberry, published in the *Agricultural Gazette* of the Department of Agriculture, N.S.W., thus summarises the desiderata of a good strawberry:—"The qualities essential to a first-class variety are: fruit large, of a regular, firm, and nearly uniform size, to the end of the season; texture fine, flesh rich and firm, with a moderate amount of acid, and with an aromatic flavour. A longitudinal cut should show no hollow space; the seeds should be deeply embedded, and the calyx set high, so as to be easily detached.

The plant should be hardy, vigorous, and strong, with perfect flowers, *i.e.*, self-fertilising, a prolific bearer, with stalks of sufficient length to keep the fruit out of the dirt."

A FEW PROFITABLE STRAWBERRIES.—The number of varieties of strawberries which, at one time or another, have found favour with growers, is now very considerable. Most of them have some special points of merit which make it more or less desirable under the particular prevailing conditions. It is only, however, by experimentation, by selection, and by observation of what others are doing elsewhere, under conditions somewhat similar to our own, that we are mainly guided in deciding upon what varieties to grow. Some of the varieties best adapted to local conditions are Australian seedlings, such as Melba, Sunbeam, etc. The strawberries described have either proved themselves profitable with us, or are highly recommended by successful growers.

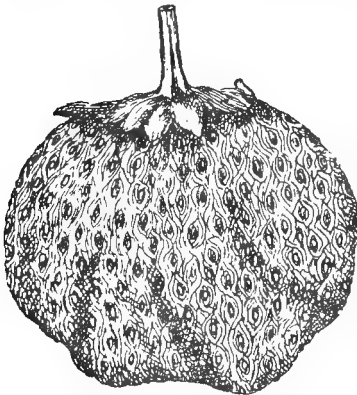

Aurie.

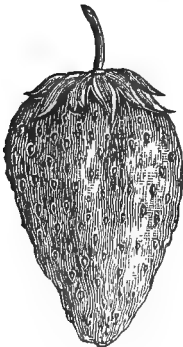

Edith.

AURIE.—A Queensland strawberry grown by Mr. A. Court, at Mooloolah, and valuable for its extreme earliness, great productiveness, and robustness. It is said to come in some two months earlier than the Marguerite Hautbois or any other strawberry. The first fruit are picked early in June, and the crop sent down to Sydney has sold at first up to 6s. and 7s. a quart.

The fruit is large, uneven, red in colour, glossy; the foliage healthy; roots, long and abundant, penetrate the soil deeply, and withstand drought well.

EDITH (*Edith Christy*).—Very early, and one of the most popular strawberries for early market. An Australian seedling. Fruit large, elongated, conical, bright crimson; flesh rather tender, white, tinged with salmon colour; pleasant sub-acid flavour. Plant strong, very hardy, and a heavy bearer. Adapts itself readily to a great variety of soils and climate. Earlier in lighter soil, especially on a N.E. slope at Kalamunda on the Darling Ranges.

MARGUERITE.—Very early and popular variety well tested in Australia; fruit large, elongated conical, or cockscomb shape, bright red, shining; flesh white, tinged with pink;

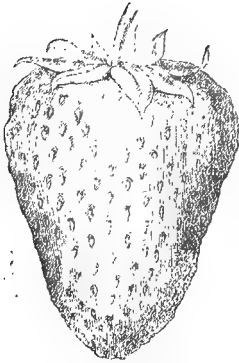

Marguerite.

early to mid-season, at the same time as Paxton. Carries well.

**PARKER EARLE (H.).**—A tall, vigorous grower, but burns badly, making, however, a good recovery; sets practically no runners, and hence only adapted to hill culture; leaf medium in size, and green in colour. Berry medium, with distinct neck, long, bright crimson, with a pronounced, rather unpleasant, flavour; ripens evenly. Productive and valuable both as a late shipper and pollinator. Requires much moisture to perfect its crop, and does best on heavy soils.

**PINK'S PROLIFIC (H.).**—A splendid late strawberry, does very well in Queensland on low, rich scrub land, being quite free from leaf blight.

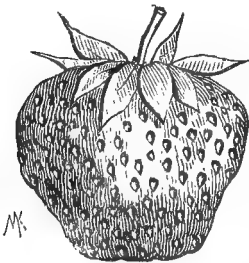

Sharpless.

core hollow, lacking a high flavour; seeds rather deeply sunk. Plant robust, very prolific and bears for a long time; a better carrier than Edith.

**MIKADO.**—Mr. W. J. Palmer, Mōmohaki Horticultural Station, North Island, N.Z.: Without exception the best strawberry I have ever met, both for cropping and flavour. The foliage is healthy and free from disease. This is a New Zealand raised seedling.

**NOBLE.**—A valuable early English variety. Plant hardy, with large leaves, prolific; fruit large, roundish conical, dark glossy red; flesh firm, solid, dark salmon colour; ripens

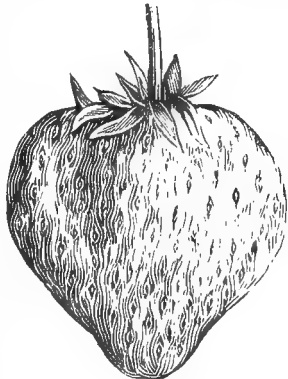

Noble.

**SHARPLESS (H.).**—A vigorous and healthy, but straggling grower, standing drought well and setting a sufficiency of runners; leaf large, rather deep green, and fruit very large, irregular, and misshapen, many possessing the "cock's comb" form so characteristic of this variety as to be generally termed the "Sharpless shape." Yet the berries are very handsome, bright scarlet, flesh pink, firm, sweet and good, but with little individuality of flavour; ripens unevenly and inclined to green tips.

Fairly productive, will never be discarded as a home berry though not so well adapted to market purposes. Does well in heavy soil.

SIR JOSEPH PAXTON.—Early to medium, excellent, of English origin. Colour dark glossy red. Flesh pale red, firm, and highly flavoured. Plant strong and productive, will not suit every district, but when it will succeed it is useful for all purposes, does well in a light chocolate soil; a good carrier.



Sir J. Paxton.  
(Two-thirds size.)

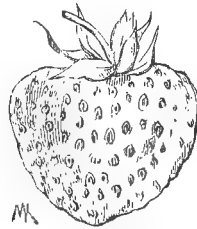

Trollope's Victoria.  
(Half size.)

TROLLOPE'S VICTORIA.—An excellent English variety, and very popular in Australia. Fruit large, roundish, even outlines; deep bright red. Flesh pale red, tender, juicy. Plants vigorous and prolific; like Edith and Marguerite, adapts itself to varied conditions, but requires heavy loam to attain perfection, ripens after these two varieties.

MELBA.—A Victorian strawberry; prolific, bearing also on young suckers which makes it almost a continuous bearer. A profitable and good market sort.

SUNBEAM.—A new Victorian variety of good colour and in other respects said to rank with the best.

NEW ETTERSBURGH.—Tree strawberry. An American sort; does well in dry locations. Robust, strong healthy foliage; fruit firm, medium, juicy, hangs in bunches.

#### PASSION FRUITS (*Passiflora*).

The family of the Passion vine is largely represented in various parts of the world. The most commonly grown species for the sake of their fruit are the common Passion fruit, *Passiflora edulis* and the *Granadilla P. quadrangularis*. The name of the genus is derived from a fancied resemblance of the floral organs to the cross and other emblems of the Saviour's crucifixion.

All the Passion vines are rapid growers, and for that reason great exhausters of the soil, which should be liberally manured. The common Passion fruit vine does well in almost any soil, but better



A well-packed Case of Passion Fruit.



Grapes cased for export.



in deep, moist, rich loam, where it bears most abundantly for a number of years. On light, moist soil, well limed and manured, the plant makes more leaf growth than on heavy lands and could well be planted wider apart, say, 12 to 15 feet. After bearing three or four full crops, the vines, unless judiciously thinned and heavily manured with bone and blood and potash (four of one and two of the other), and well cultivated, give a large proportion of immature fruit. The seeds are hard, and do not germinate very readily. The young plants are easily raised by squeezing ripe fruit in a sandy seed bed in boxes, like tomatoes. When the plants are strong enough, in their second leaf, they are picked out and transplanted in tins or pots and finally set out in the spring and trained on trellises like grape vines. The system of trellis recommended is described in a previous chapter dealing with pruning. Unless the situation is well sheltered from the wind, the young plants do best when protected by a wind-break, made of a strip of hessian or bagging fastened to three stakes, driven in a triangle, round the vines. As the young plant grows, the young shoots are tied to the wires until the vine is well established, when the ties are cut off lest they cut into the growing canes.

If the Passion vines have been well treated, they will bear a fair crop the second season, *i.e.*, the third year from planting, and under favourable conditions three to four cases per vine are not uncommon.

In practice the fruits are not picked from the vines, but allowed to drop on the soft and well cultivated land. The fruit, which is egg-shaped, is ripe when it turns chocolate colour. It contains a watery pulp of a pleasing aromatic flavour, with a delicate acid taste. It carries well. The best way to eat it is as one takes a boiled egg, that is, cut off one end and take the contents with a spoon, adding a few drops of port wine instead of salt and pepper.

For marketing, half-cases are of handy size; they are lined with paper and hold of first grade fruit three rows.

The remainder is further graded into second grade, which is like the first grade, but smaller, and into third grade or "culls," which comprises small fruit deformed and of bad colour.

It is worth repeating here that the winter crop and not the summer crop is the profitable one, and the methods of securing the result aimed at are further explained in the chapter on pruning. As the plants are not long-lived, fresh planting must be arranged to secure a continuance of cropping.

#### MELONS.

A quick return on newly cleared and cultivated land may be derived from water melons, rock melons or pumpkins, while the young fruit trees are growing.

A warm location, alluvial soil, or a light but moist free soil is the best, provided the distance to market be not too great. Deep ploughing is an advantage. The "hills" are placed 8 to 10 feet apart for melons and 6 to 8 feet for rock melons: they should not be built above ground. Five to six seeds are planted in each hill; these are planted a few inches deep. When the plants are young, they are thinned out to two in each hill. The surface of the hills need not be raised above the level of the ground. Spring is the time for sowing the seeds, as the plants are gross feeders. Manuring should be on the liberal side, bone dust and dried blood preferably. Thorough cultivation will keep the ground moist enough in the coastal zone, although irrigation considerably increases the yield of the crop. When insects are troublesome, a dusting with air-slacked lime, ashes, soot, etc., is generally sufficient to keep the pest under control.

Of water melons, plant the sorts which do best in the locality.

"Cuban Queen" has long been a standard sort, although not the best to eat, it is a most reliable cropper, the others needing irrigation. It is also the easiest handled, and can be sent out by the truck load, either in bags or loose and does not burst.

It requires cultivating when it is young, after it has commenced running it is all right. Yields on the Swan Valley, which is close to the Metropolitan market, vary from 3 to 9 tons to the acre. The fruit weighs 6 to 30 lbs. but the best marketing ones weigh 12 to 18 lbs. They should be graded when sold and they are sorted out in the auction market in square frames about 3ft. square, 1 dozen to 2 dozen in each. Water melons are sold by the cwt. or by the dozen. Four to 10 melons weigh 1 cwt., or on an average eight. The crop is sown in September and harvested in January, or four months after.

Inexperienced growers are sometimes puzzled as to the right stage to gather the melons.

Water melons often sound hollow to percussion and when fit to pick the stalk begins to wither, although this is not an infallible sign. The tendrils wither, a crackling sound is heard when pressing lightly on the melon. One of the surest indications, however, is the clearer colour of the rind, which at times shows a faint tint of yellow. Musk and Rock melons, when ripening, sometimes crack more or less up to the stem. On pulling they should come off clean. Some of the larger varieties do not part so readily from the stem, and, if pulled, show a large hole in the rind; with those it is best to cut the stem.

### TROPICAL FRUITS.

Of the several Australian States, two—Queensland and Western Australia—possess natural conditions which permit of the profitable cultivation of tropical crops and fruit. It is true of the Common-



wealth territory in the tropics, but its overland distance from the populous markets of the more temperate latitudes will always prove a formidable obstacle in the way of providing the southern markets with productions of tropical latitudes. The cultivation of the sugar cane has already proved highly remunerative in Queensland, and other crops as well await development at the hands of settlers in the warmer latitudes of both States.

Coffee, cocoa, cotton, and tea also grow with great luxuriance, but at present would prove risky ventures, on account of the lack of suitable labour to exploit them.

Tropical fruits stand differently. To the increasing number of settlers on the sea board of tropical Western Australia they would prove a blessing and a luxury, whereas the population at the South could absorb large quantities of such of the delicious tropical fruits which are capable of being raised at the Nor'-West and the North. Among such crops are:—

#### ALLIGATOR OR AVOCADO PEAR (*Persea gratissima*).

Is a native of Mexico and Brazil, whence it was introduced into the West Indies. The tree, which has somewhat the appearance of the apple tree, is a fine spreading evergreen, with leaves large, oblong, and smooth, and of a bright green colour. The tree bears towards the extremity of the branches, the fruit being in appearance not unlike large pears. They weigh from  $\frac{1}{2}$ lb. to 2lbs. each. They consist of a single large rugged seed wrapped up in a membranous cover, inside a firm buttery flesh of a bright greenish yellow colour. The skin, which changes from bright green to yellow green, is tough and leathery, and when the fruit is ripe can be peeled clean off the pulp, to which it firmly adheres until then. Very unpalatable when green, it is deliciously melting, with a delicate fresh walnut flavour, when ripe. The pulp contains six to eight per cent. of a greenish oil. In the tropics it is also sometimes eaten with pepper and salt or with sugar and kirsh, or with port wine.

The Avocado Pear thrives as well beyond the tropics, and should be an acquisition to the orchards from Sharks Bay northward. It is easily grown from seeds or from young cuttings. It requires moist soil, and is unsuited for droughty localities. When marketing it should be picked before it becomes soft, and should be carefully packed, when it ripens in a week or 10 days after gathering.

#### BANANA AND PLANTAIN (*Musa* sp.).

Probably the most widely known fruit in the world, although it does best in the tropics proper. The plant grows from a rhizome root, a cylindrical spongy stem, surmounted by an ornamented head made up of large leaves.

The Banana may be said to be one of the most useful productions of the vegetable world. Its fruit, either in the green or the ripe state, is highly nutritious; its stem yields a valuable fibre, and it affords, in tropical climates, a protecting shade as well as material for thatching, mats and baskets, and an endless variety of articles of everyday use.

It is essentially a hot climate plant. In some sheltered and favoured parts of the more temperate zone it may be made to grow and even fruit, but the plant never attains the luxuriant growth, nor is it as fruitful as within the more congenial tropical regions. Protection from the withering blasts of high winds is essential, and if properly protected, it can be grown quite near to the sea coast in an atmosphere charged with salt. From long propagation from offsets or suckers, seed has almost entirely disappeared from the fruit, although, at times, a few are found which are capable of giving rise to new varieties.

The suckers used for planting should be about a couple of feet long, and four or five months old. When smaller they are delicate; when longer they do not root so easily. As many fibrous roots as possible should be secured when cutting them off the parent plant. In a little over a year's time, in favourable localities, the first stem flowers and bears a bunch of fruit, which takes four or five months to develop. That first bunch is, as a rule, not so fine as that from the second sucker and the few which succeed it. After a few years the ground becomes impoverished, and needs stirring up and manuring. Complete chemical fertilisers, particularly rich in potash, at the rate of  $1\frac{1}{2}$  lbs. to 2 lbs. per clump, can be applied. Under favourable circumstances a banana plantation remains profitable for seven or eight years. Each adult stem bears one bunch, which consists of a long stalk with fronds consisting of ten to fifteen hands spirally arranged round it; each hand eight to twelve bananas or more. The bunches, according to variety and size, weigh from 10 to 60 lbs. each and over. All banana trees are good bee plants.

Bananas are great exhausters of the soil. They require rich, moist soil. As the eating varieties do not seed, nature provides them with numerous suckers. In some places these suckers are grown at intervals of about 12ft. to 15ft. in trenches 2ft. or more deep and about 3ft. wide. This gives 200 to 300 holes to the acre. The larger growing bananas, such as the Sugar Banana, Lady's Finger, Plantain, etc., require 20 to 25 feet apart each way, or 100 to 70 plants to the acre. Every now and again a good dressing of cow-dung and a copious watering is given, and for that purpose the trench system is very suitable. Where the soil is naturally very rich and moist the trenches are dispensed with. Three or four stems are left to each clump, and all the other suckers are cut off with a sharp spade and either removed for planting or left to rot on the ground, together



Banana Plantation in a Windy Locality.



Cavendish Banana in the tropics.



with the chopped up stems which have just fruited. This form of mulching keeps the ground cool and checks the growth of the weeds.

The banana is not left on the plant until fully ripe, but is cut about a week or ten days before. If intended to be shipped long distances the spike is cut even earlier, being what is called "three-quarters" fit, and the fruit gradually becomes yellowish and more sugary. The bunch must be cut with a portion of the stem retained for easier handling, and the terminal bud is removed. When transferred to market it need be handled with the greatest care, as a bruise that may not be apparent at the time will soon cause decay of the delicate tissue of the fruit. A great number of bunches are rejected when repacking for market owing to careless handling in the fields or during transit. Three grades of bananas are cut from the bunch, large, medium and small. They are packed in crates with open slats, and should be stacked on deck in the open air, 30 to 40 doz. per crate.

Every banana-growing country proves that until growers can market this fruit in the bunch, their industry will not be the success it should be. The success of Fiji in the Australian market; of Jamaica in Europe and America is largely owing to the fact that most of the fruit arrives in bunches.

The weight of the bunch at times pulls the plant down unless it is propped up by means of a forked stick or a stake sharpened at each end, one in the ground and the other into the soft stem.

Bananas which ripen on the plant lose the delicate flavour of those cut from bunches removed when fully grown, but before the ripening stage has set in.

The "plantain" is gathered at different stages. When three-fourth grown it is rather milky and contains much starch. At that stage, if boiled or roasted in ashes, it is almost as nourishing as bread. Shortly after this stage, when full grown but still green, it is not so starchy, but contains more sugar. In this state it is eaten as an accompaniment to meat. Lastly, when quite ripe it becomes sugary, and is then eaten either raw, roasted in ashes, or in the form of fritters.

The banana is seldom eaten cooked in the unripe stage, but is allowed to mature, when it is soft, full of sugar, melting, and is possessed of a peculiar perfume.

The Banana constitutes a perfect food. Medical men recognise that banana flour is excellent as a food for infants and invalids. The scientific name of the fruit—*Musa sapientum*—means "food for the wise man."

As regards its food value, it is more nutritive than the potato. It contains 27 per cent. of dry nutritive matter; the potato gives 25. The 27 per cent. of dry matter are approximately made up of 2 per cent. of nitrogenous matter and 22 per cent. of saccharine

substances, with small quantities of fibre and ash constituents. Of the ash constituents, potash represents 50 per cent. and phosphoric acid 15 per cent.

Until lately Western Australia has been drawing supplies of this fruit from Fiji and Queensland. Since then Java, which is nearer our ports, has diverted the trade. On account of the protracted time required in shipping them from the extreme East to the West coast of Australia, the fruit we receive is of very indifferent quality. It had to be picked before it is fully developed and when quite green, and it therefore ripened in an artificial manner in the crates used by the shippers. Bananas were then introduced in our market during the winter and spring months when all fruits are scarce, and there is no reason to doubt that considerably larger quantities would readily be consumed if better fruit grown nearer our own market was obtainable, more especially if sold at a lower price.

In 1918 there were 7,817 acres under Bananas in Queensland, and the published returns are 1,267,640 bunches, an average of 162 per acre, or reckoning the bunches at 10 dozen each—a low average under favourable conditions—1,620 dozen.

In the nine years, 1910-1918, the average bunches per acre numbered only 158, or 1,580 dozen.

In the decade, 1890-1899, the average was 467 bunches, or 4,670 dozen.

In New South Wales there were in—

1910 under Banana crop . . . . .	100 acres.
1919 there are . . . . .	3,000 acres.

In Fiji the acreage under Bananas is 4,000 acres. There is still ample room for expansion. In the cities the sales could be much increased. Rural towns and the back country hardly ever see Bananas offered for sale. The consumption of this nutritious fruit would more than double if prices could be lowered and a better article offered for sale. The waste is very great in handling this kind of fruit. It has to be carried on deck and covered with tarpaulin when the sea is rough. The soft spray and the confined dark atmosphere cause a great deal of waste. These conditions would, to a great extent, be minimised by shipping the fruit from our North-West ports, a shorter distance away and in smoother seas.

In New South Wales and Southern Queensland, bananas are grown on the hillside, where the use of horses and implements is often impossible, but in the north where frost is not to be reckoned with, they are preferably grown on flat country where machinery can be used in the cultivation.

Where handwork only is possible it takes one man to properly handle four or five acres of Bananas.

Under other conditions and where horses can be used a larger area can be attended to.

Apart from the fresh fruit, a considerable quantity of "desiccated bananas" and "banana flour" is now placed on the market which keeps good, if kept dry, for years. When cooked it retains the pleasant taste of the fruit. It can be dried at a small cost and carted to the sea-port at leisure, taking up far less space in transport than the perishable fresh-plucked fruit in rind. Under the Commonwealth Bounty Act a bonus of 10 per cent. on the market value is offered for quantities not less than 5cwt.

This industry, and also that of "banana figs," or dried fruit compressed and wrapped up in bundles has taken some importance in the Cameroons. Some of the factories handling 3,000 bunches a day each.

There is room for a profitable trade in this class of fruit, both fresh and manufactured, within the State.

Bananas would do best in the Kimberleys, where the rainfall is heavier and reliable, and where, provided they are dried and manufactured, long distance transport would not prove a barrier to the development of an industry capable of being handled by white labour. They should also be irrigated as well as fertilised, as previously stated, to ensure larger bunches, as the roots must be kept moist.

When in North Queensland I visited, in 1910, on the Johnstone River, banana plantations 10 to 40 acres in extent on jungle land leased for £1 per acre. The trade is mostly in the hands of the Chinese. That State had then 5,000 acres under bananas. The full bunches, which carry 15 to 18 dozen fruit, are shipped whole, each bunch carrying a tin tag on a piece of wire run through, with the number of the shipper on it. Smaller bunches are cut into hands and the green bananas are closely packed in cases about the size of 4doz. beer bottle cases. Each bunch averaged 6s. in Melbourne, the net return Geraldton (now Innisfail) being 3s., or 2d. per dozen. Cases, carriage, freight, wharfage, and commission absorb the greater portion of the return, and the industry is one which leads to the circulation of a good deal of money.

In Queensland the yield varied then from 150 to 300 bunches per acre; the total average being 200 bunches, and the average net return about £20 per acre.

The varieties of bananas cultivated in various countries may be numbered by the score. Two groups are known, viz., the edible and the fibre-producing sorts.

The edible bananas are often referred to as "Bananas" or as "Plantains;" and a good deal of confusion has in consequence resulted. Perhaps the best distinction is to designate as "Plantains" those varieties which are generally consumed cooked, and "Bananas" the varieties which are eaten fresh and ripe. As a rule the stem of the first is green, and that of the latter somewhat mottled.

PLANTAINS (*Musa parasidiaca*).—Long, large fruits. The Dacca plantain is about nine inches long, the Madagascar plantain as large as a man's forearm; while it is reported that in the Philippines a couple of fruit of plantains are a load for a man. The trees are 15ft. to 18ft. high. The fruit is cut before maturity, when rich in starch, and cooked or allowed to ripen, and eaten when sweet.

BRAHMIN BANANA (*M. Sapientum*) is small. A native of India; its cultivation has spread all over the semi-tropical world. The tree is tall, reaching 18ft. in height; should be planted in well sheltered and warm spots. The fruit, eaten when sweet and ripe, is of the best.

To this group belong the varieties known in Queensland as the Sugar Banana and Lady's Finger Banana. These kinds are not grown commercially in Fiji as they do not carry well.

THE GROS MICHEL, a West Indies kind, is the favourite Fiji Banana. It has been introduced to Northern Queensland, but experiments in New South Wales and in Southern Queensland have not been satisfactory. The rainfall is not sufficient; the Gros Michel can, it is said, do with up to 200 inches of rain annually, or its equivalent in irrigation water on well-drained soil. The difficulty of procuring healthy suckers would retard its expansion as disease is rife in Fiji, and Jamaica is not free from it. It is a much better carrier than the Cavendish, having a thicker and tougher rind. When ripe it keeps its colour longer and many consider its colour better than the Cavendish. This kind, like the Cavendish, is recommended as being the best shipping banana.

CHINESE BANANA (*M. Sinensis* or *Cavendishii*) is a comparative dwarf species, and a squatter plant, with large, long leaves, and attaining a height of six to nine feet. It produces excellent fruit, stands high winds better than the preceding; is altogether more hardy and stands a greater amount of cold weather. The tree bears early most excellent fruit.

#### BREADFRUIT (*Artocarpus incisa*).

The botanical name is derived from the word *artos*, bread, and *carpus*, a fruit, and the generic name *incisa* in contradistinction to the genus *integrifolia*, or entire leaved, which applies to the Jack-fruit.

This plant is distinctly tropical, and requires for growing and bearing a deep moist soil, well sheltered in a uniformly warm climate. A handsome evergreen tree, 20 to 30 feet high, it has its native habitat in the islands of the Pacific and the Malay Archipelago, whence it has been introduced into Mauritius and Madagascar, where it thrives well. Such glowing accounts were given of this fruit by the early navigators, that steps were taken to introduce it into the



West Indies towards the end of the eighteenth century, and the expedition, which was connected with the historical mutiny of the "Bounty," first failed to achieve that end. A second attempt was, however, made and again entrusted to Captain Bligh, who succeeded, and the tree has since become quite common in the West Indies.

The breadfruit, together with the banana, forms a staple article of food of the islanders of the Pacific. The average size of the fruit varies from that of a child's head, and often weighs 30lbs. and more. It is more or less round or oval in shape, and is carried on the stem, and the main branches. Externally it is not unlike the Jack-fruit, which is illustrated at page . The outer rind is rough, and covered with diamond-shaped facets. The inside is a white fibrous pulp, becoming succulent at maturity, when it is rich in starch. Eaten boiled or baked, it tastes of dough, with a pleasant nutty flavour, and is very sustaining. Like the plants of the same family, the breadfruit tree exudes, when freshly wounded, a sticky latex which is as strong as bird-lime. The breadfruit would, I dare say, thrive in the Kimberleys and the more tropical regions of this State. It is propagated from root-cuttings, which readily sprout, and from which shoots can be detached with a heel attached. In tropical West Africa another tree belonging to the same natural order exists. It is chiefly grown for the sake of its seeds which, roasted or boiled, taste somewhat like chestnuts.

#### BULLOCK'S HEART (*Anona reticulata*).

One of the "Custard Apples," constituting a fine evergreen tree 30 to 35 feet high.

It grows readily from seed. The fruit is larger than a pear, and its shape has won it its name; in colour it is a brown chestnut. The pulp inside is eaten with a spoon, and is much liked. In the tropics the tree is vigorous and prolific. The fruit should be picked when hard, and ripens a week or 10 days after gathering. A tree grown from seed in Mr. George Lefroy's garden, Guildford, ripens its fruit on the Swan in September.

The illustration is from *L'Agriculture pratique des pays Chauds*.

#### CUSTARD APPLE, SYL. CHERIMOYER (*Anona cherimolia*).

A native of Peru, widely grown in tropical and semi-tropical countries. The tree, which grows 10 to 12 feet high, requires rich, moist soil, in a well sheltered place. The leaves are oval, the flowers very fragrant and solitary, the fruit globular or heart-shaped, three or four inches in diameter, greyish-green turning to brown when ripe. The flesh, in which some 30 or 40 hard brown seeds are embedded, is much relished, the fruit being eaten when soft and yielding to the touch. For marketing it needs gathering when hard, a

week or so before eating. I have seen in Queensland one kind which attains the size of a child's head, and is full of a sweet pulp. The average yield there is 40 to 45 bushels, worth £35 per acre.

Two other Custard Apples—the SOUR SOP (syn. Corossol), *A. muricata*, and the SWEET SOP, *A. squamosa*—are trees of the same family, which are grown in the tropics and valued for their fruit.

#### THE COCONUT.

Personal inspection of coconut plantations at the Aru Islands, and in the Malay States and Java, leads me to believe that the sea-coast from Port Darwin to Beagle Bay, Kimberley, is in many places very suitable for the cultivation of this tree.

Several varieties are grown of which the large Java nuts are particularly prized in Java and also in Ceylon, but it remains to be seen whether under less favourable conditions other varieties bearing smaller nuts would not be more profitable.

The nuts should be selected from picked trees, and are placed in trenches with the stem part up. Ashes and salt are placed in these trenches, which are filled with soil and kept moist. When the nuts have sprouted they are planted in holes dug 25ft. to 30ft. apart, and also manured with compost and ashes, and, if the ground is not naturally salty, some salt is added. I have seen splendid groves in sand right against the sea. The trees commence bearing in five to six years, and carry from six to twelve nuts or more on each flowering spike, which come out right through the year, the trees yielding fifty to one hundred nuts during the year, and continuing to bear for half a century or more. In Malaya I have seen splendid groves established on poor, gritty, sandy loam with a coarse sand subsoil. Trees in good bearing average 10 to 12 nuts at each picking every two months, or 60 to 72 a year. In Ceylon a plantation averaging 50 nuts per tree a year would be worth £100 per acre, and in the Malay States a plantation yielding the same average, which I visited, was estimated to be worth £60 to £70 per acre. In Java I also had an opportunity of visiting a small plantation from which the nuts were sold on the trees at 5 guilders per 100 (8s. 4d.); the trees, which averaged 50 nuts, brought in a clear income of 4s. 2d. each. On each tree was hanging a small gunny bag containing a mixture of salt and ashes, which are washed down the stem by the rain and fertilise the tree. These also receive occasionally some manure placed around the stem in a ring from which the soil had been dug out.

If intended to be tapped for juice or "milk," the fruits are not allowed to mature. Ripe nuts give a coarser fibre (coir) than when unripe, but if "copra" or the thickened milk is required the fruit must be ripe. The coir is torn off by means of a shod stick placed upright in the ground; the shell is then broken and the copra

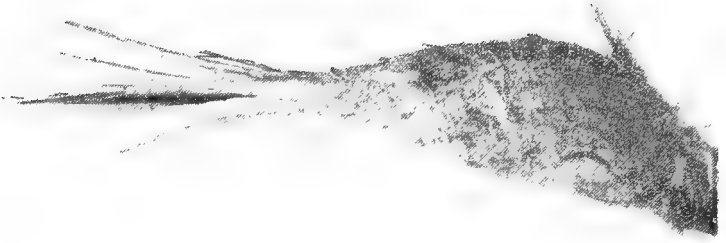

Date Palm Sucker.

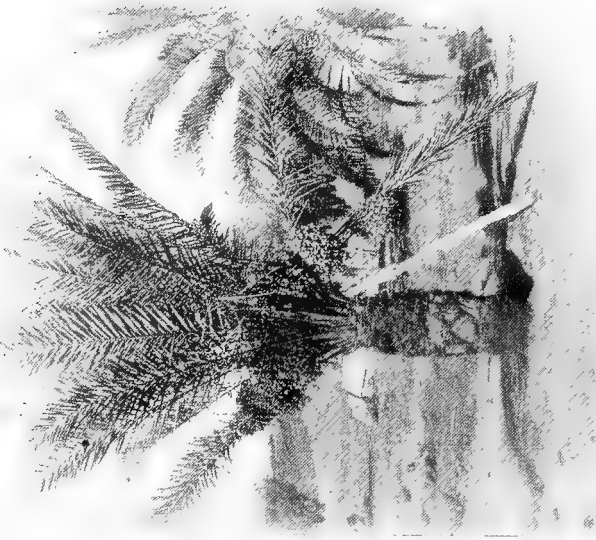

Date Palm, on a North-West Station.



quartered and dried in ovens or on cement terraces as shown in the photograph I took at a coconut plantation visited in the Malay States. Copra-drying should be done immediately after the opening of the nuts, and should be finished in 24 hours. The result of experiments in New Guinea show that 4,500 nuts give a ton of copra, and freshly cut kernels give 63 per cent. of dry copra, worth £24 a ton, and a steady demand exists for it. The extracted oil is largely used for soap making, lubrication, for culinary purposes, and of recent years a refined vegetable butter is manufactured at oil mills in the South of France, and largely exported to Russia and Northern climates, where it remains hard and congealed without trouble. It is claimed to be superior to lard or butter for culinary purposes, baking, or confectionary, and much cheaper.

If grown, as explained, in Kimberley, along marshy flats and moist, salt, sandy, places close to the sea, it is improbable that the tree would be seriously attacked by white ants.

#### THE DATE PALM (*Phoenix dactylifera*).

As its name implies, the Date belongs to the Palm family, to which also belong the coconut and other palms. Unlike these, it throws, when young, offshoots or suckers ("djebars," in Arabic) at the base of its stem. Later on, when the tree is in full bearing, it ceases to throw suckers. The stem of the tree grows from a terminal bud, and remains of the same diameter all through its existence. The leaves, which are feather-shaped, measure 10 to 15 feet in length, and are persistent. The tree is *dioecious*, its staminate (male) and pistillate (female) flowers appearing on separate individuals. If grown from seed, about half the number of resulting palms are male, and about half female. In cultivation, however, this number is considerably reduced, and the staminate trees are cut off and a small proportion only allowed to grow, viz., about one in 50. As it is important that the male flowers and the female trees should blossom at the same time, it is advisable to leave at the start a surplus of male trees which can subsequently be weeded out. With the help of artificial pollination this number may even be reduced. For that purpose a piece of male flower is tied to the female inflorescence of the pistillate tree at blossoming time. To provide pollen for fertilising early blossoming female trees the Arabs always keep a few bunches of male flowers from the previous year. These are placed in tight paper bags or in glass jars covered with calico, as cockroaches would otherwise devour the pollen. These packages are kept in a cool place. The pollen is said to keep without deterioration for two years. The reproduction of the date palm by seeds is not much favoured, and often results in worthless trees; and it is preferable to effect the multiplication of the good varieties by means of suckers. These transmit the sexes and the characteristics of the parent plants.

Failure in connection with the profitable cultivation of the date palm is often due to the fact that some imagine that the tree is one fitted for any hot, arid desert. Its likings have, however, been fittingly summed up by an Arab proverb: "The date palm, the queen of trees, must have her feet in running water and her head in the burning sky."

It is a fact worth noting that a very dry atmosphere favours the production of dates of high quality, and that the best dates are grown in the hottest regions of Sahara, and remote from the cooling and humid neighbourhood of the sea. In fact, heavy rain, followed up by a few days of cloudy weather at the period of the ripening of the fruit, at times spoil the date crop.

Permanency of moisture is needed more than any great volume of water at any time. When this is available, even if the water is alkaline, the hot winds of the desert do not injure it, and it will thrive in a climate too hot for any other known fruit.

Suckers of good strengths and weighing 20lbs. to 30lbs. are preferable, if sent a long journey. Large shipments have of late years been sent from Northern Sahara by Mr. W. T. Swingle, Agricultural Explorer to the Department of Agriculture, Washington, from Biskra and the oasis around a distance of 400 miles to the south of Algiers, to Arizona and California. These consignments consisted of suckers removed from the parent palms by means of a sharp chisel and a mallet. They were simply packed in the date palm fibre bags and slung on pack camels, slipped three in a bag, and directed to the nearest railway line, whence they were carried to Algiers, dipped in water, and packed in wooden boxes, after having been wrapped in moist moss or sphagnum, and shipped as ordinary cargo. This method of packing proved vastly cheaper than the shipment in tubs which had been followed by the French and British Governments in shipping Algerian palms to South Australia. The suckers were at times a long time growing, and some, after planting, remained for 12 months dormant; but 93 per cent. eventually grew. Date palm trees raised from seeds are six to eight years before they bear, whereas from suckers they begin to fruit when five or six years old, and come into full bearing when 10 or 12 years old, and continue bearing from this stage, if well cared for, until they are 100 years or more old. The average quantity of fruit borne annually amounts to 100lbs. to 200lbs.; some trees yielding as much as 400lbs or even more.

Although the Arabs plant the date palms without any system, the French colonists find it preferable to plant them in rows 25 to 30 feet apart; the wider the better.

The flowers of the date palm are white, and are carried on an inflorescence not unlike the tail of a horse. If the flowers have been pollinated, two of the three fruit produced from each flower

fall, leaving a single date. If, however, the flowers have not been fertilised, all three dates generally remain attached, and continue to grow, crowded and deformed. These are seedless; never properly mature; and are of no value. The cultivator thus knows the bunches which are not fertilised, and cuts them off. The fruit is at first green, and gradually turns bright red or bright yellow. As ripening proceeds, the yellow dates change to a clear amber colour, and the bright red ones become reddish brown; they become translucent, and from astringent and unpleasant to the taste become charged with sugar.

Several types of dates are known, one only being exported—the soft date of the Deglet Noor type. These contain as much as 60 per cent. of their weight in sugar, and being, as it were, candied on the tree, keep without trouble. Others are more syrupy, and do not dry readily; like the grapes which are cured into raisins, they are either eaten fresh from the tree or they are dried.

A third type are almost dry, and, although not exported, are consumed by the Arabs, for whom they constitute an important article of food.

For our requirements in Western Australia, it is important that we should secure early ripening sorts, which would not be affected by the tropical summer rains.

Of these, one of the most important is the Rhars, which is extensively cultivated both by the Arabs and the French colonists of Algerian Sahara. It is a syrupy date of good quality, which is packed in skins or boxes for shipment. This date palm grows rapidly, and fruits when young.

The Tedalla is another variety which can be easily dried. It is very large, sometimes three inches long, and ripens at the same time as the Rhars. The tree is vigorous, and bears large crops of fruit which matures early during the rather short and relatively cool summer of the coastal region of Northern Algeria.

The Deglet Noor, or "date of the light," a later variety, is better adapted for drying. The province of Biskra derives from the sale of the djébars, or suckers, of this variety an increasing revenue; the djébars of Deglet Noor selling for about five francs each, whilst those from Rhars sell for three francs.

The Deglet Noor is cultivated throughout Western Sahara wherever the season is long enough to enable it to mature. It is a medium-sized date, amber-coloured, and translucent when ripe, with a soft flesh of excellent flavour. These dates do not become sticky, as most of the soft dates, and can be eaten without soiling the fingers. This variety does not fruit abundantly unless well fertilised and irrigated.

Other good varieties are cultivated in Egypt and along the Persian Gulf which present features of great value.

The gathering, curing, and packing is of the simplest. Varieties of the Deglet Noor type become, when ripe, self-candied on the trees. They are either picked singly from the bunch as they ripen, or else the whole bunch, weighing 10 to 20 pounds and even more, is cut off when the majority of the dates show signs of ripening, and hung up for a few days in a dry and shady place. The best fruit is picked and arranged in layers in neat light boxes holding from one to ten pounds.

The syrupy sorts, such as the Rhars, are not so easily handled. The Arabs hang up the bunches, and collect the sweet juice that drains off, and which they call date honey, into jars; the drier fruit being subsequently packed tightly in boxes, skins, or straw bags, and exported.

From the foregoing it will be seen that the cultivation of the date palm is one particularly suited to the arid regions of Western Australia, where the summer is hot and long, and where water—even not of a particularly fresh description—is often obtainable at a shallow depth. They do best when grown on moist ground and are often set on places where there is standing water a few feet from the surface.

A profitable market is within our reach in supplying the requirements of Australia; but nothing but the best varieties should be planted.

The Forestry Department has in several instances supplied exploring expeditions with a quantity of dates, the seeds of which have been sown at soaks in the interior where water is found at the surface; but sufficient is known of the date to doubt whether the trees which have been issued from these seeds will equal in merit some of the varieties mentioned.

The local government of Algeria have on several occasions generously assisted in procuring for other countries some of the best dates grown within that province, and from that source consignments of suckers could well be drawn. It is important, should such introduction be made, that these suckers be dipped into water for a day on arrival, and then fumigated by means of hydrocyanic acid gas, in order to destroy the date scales (*Parlatoria victrix*), one of the most troublesome pests of that useful tree.

Even in their natural home in Northern Africa, and particularly in Algeria, I have not seen finer date palms than those growing on the Gascoyne, around Roebourne, and at Beagle Bay.

At Pyramid, Sherlock, Mallina, Portrea, and Boodaree Stations, without mentioning Woodbrook, Tambray, Millstream, and others I could not visit, the date palms proved itself the best fruit and ornamental tree grown.

The suckers of Algerian palms I introduced seventeen years ago from Biskra in Algeria, are now good sized trees at Portrea (F.



(Craig), Boodaree (T. A. and A. E. Hardie), and at the Beagle Bay Mission. They blossomed ten or twelve years ago and have since entered the period of productiveness.

I tasted some dates grown at Tambray on the Fortescue—one in particular is as good as the best date imported.

At the Beagle Bay Mission there are some 70 odd date palms planted, and the community there intend setting out a larger plantation.

It would be advisable, in view of the fact that the earlier dates ripen their fruit at the North-West about February, to introduce some of the later ripening kinds which would mature after the rainy season (April) when the fruit would not ferment. The climate there, which is dry from April on, enables us to harvest a date crop without seeing it spoiled by the rain, as is the case in Queensland in particular, where the palms grow well, but are said not to fruit satisfactorily.

Referring to the possibilities of starting an important date industry at the North-West, I previously pointed out:—

Whereas there is a duty of 3d. per lb. on dried currants, raisins, and other fruits, the duty on dates is only 1d. per lb., but as a good-sized tree bears from 1 to 5 cwt. of fruit annually, that industry is protected to the extent of about 8s. to £2 per tree, and if freshly ripened dates could be placed on the Commonwealth market—and we can do it—the consumption of that fruit would increase at a rate it is difficult to gauge. In addition to this duty a bonus of 1d. per lb. is offered for 15 years for quantities not less than 10 cwt.

Date palms offer very good shelter for fruit trees. They begin to bear from the fifth to the sixth year, but are not in good bearing until ten years or so after they are planted. They continue bearing until they are 100 years or more old. Fair trees average 100 to 200 pounds of fruit a year.

As mentioned above, if the flowers have been pollinated, of the three fruit forming to each flower two drop, leaving but one; if not all three dates remain attached, and become deformed through overcrowding, and never mature properly, being without seeds, and of little value. The cutting off of the surplus clusters is delayed until this point is ascertained. Only two or three clusters, which will bear 10 to 30lbs. each, are left on young trees, and eight or ten on old trees. Some kinds are shy bearers and others overload themselves.

Some kinds are cut, packed, and shipped as soon as they have ripened, and in the case of the choice dates the fruit which has first ripened is hand-picked, arranged in rows in boxes, and marketed. The inner fruit thus ripens better.

With other kinds the whole bunch is cut off when most of the dates are ripe, and the rest begin to ripen; they are hung up in a dry shed, when any date which has begun to ferment is removed.

THE GUAVA (*Psidium*).

One of the hardiest of all tropical fruits, its cultivation can, in favourably situated places, be extended to semi-tropical regions; and in Western Australia it flourishes alongside the orange, the apple, and the pear. In the cooler regions the Guava is easily kept within bounds, whereas in the tropics birds and cattle freely distribute it over wide areas; while its easy suckering habits under the tropics cause it to spread wherever it grows. The tree is an evergreen, varying in size from that of a shrub three or four feet high to a tree of 12 to 15 feet. It grows readily from seed, cutting, or sucker. In size, the fruit varies from that of the tomato to that of a duck's egg, while species are even larger. The internal structure of the fruit is somewhat like that of the tomato. The flavour is peculiar and pronounced; it is not always liked at first, but cooked or stewed with sugar or into a jelly, it is greatly relished by everyone. The crop ripens late in winter, although some varieties bear fruit pretty well all the year round. The plant dislikes stagnant water, but grows readily on sand and clay alike, although a light loam suits it best.

BRAZIL GUAVA (*P. Araca*).—A shrub four to six feet high, growing in the West Indies, Guiana, Peru, and Brazil, where it is found in dry, high-lying places. Leaves oblong, obtuse, soft to the touch above, somewhat hairy below; veins reticulate, somewhat raised; peduncles axillary, one to three-flowered. Fruit ovoid, greenish yellow, flesh white, of excellent taste.

STRAWBERRY GUAVA (*P. Clatleyanum*) or PURPLE GUAVA.—A native of Brazil and Uruguay. One of the hardiest of the guavas, thriving over a very wide range of latitudes. A shrub or small tree of five to fifteen feet high. Branchlets smooth; leaves smaller than those of the former round species, obovate, thick, and glossy; peduncles solitary, axillary, opposite, one-flowered; fruit almost spherical, tapering at the eye, small, rarely exceeding  $1\frac{1}{4}$  inches in diameter, fine deep claret colour, with numerous brown dots on a slightly roughened surface. Pulp fleshy, soft, and juicy, purplish red next the skin, but white at the centre, with a strawberry-like flavour, and free from the strong odour of *P. Guayava*.

Another species, the "Mexican Guava," sometimes called "Yellow Cattley Guava," is also cultivated, and has proved very hardy. In flavour it is somewhat tart, and possesses little of the peculiar guava smell.

THE LEMON GUAVA (*P. Guayava*) syn. *P. pomiferum*.—A shrub or small tree, eight to sixteen feet high; leaves, four to five inches long by two inches wide, oval to oblong; lanceolate, smooth above, pubescent below, peduncles three to many-flowered; fruit, two to

three inches in diameter, globose, yellow, aromatic, somewhat astringent. Very good for jellies and preserves. There are several varieties of this species, which differ slightly in form, size, and colour. One variety is pear-shaped, the leaves are acute, peduncles one-flowered, smooth skin, yellowish when ripe. This variety supplies most of the guava jelly of the West Indies; it is also preserved and canned as are other frutis. This matter is touched upon in a subsequent chapter.

#### THE JACK FRUIT (*Artocarpus integrifolia*).

Is closely allied to the Breadfruit trees, but is hardier, and a larger tree. In size it reaches 30ft. to 40ft. and is a very quick grower. The branches, which are numerous and spring all over the trunk, carry a thick evergreen foliage which is much liked by stock. For that reason, if planted for ornamental purposes, the young tree should be protected by means of a tree guard for the first few years of its growth. The Jack tree, which is a native of India, is now naturalised all over the tropical world. Several varieties are cultivated, and amongst others the "Honey Jack, and the "Root-bearing Jack"—an esteemed variety which bears excellent fruit on its superficial roots. The tree is easily grown from seeds, which germinate readily and come to bearing at an early age—three or four years after starting. The fruit is extremely heavy, and is carried along the main limbs or the trunk. In weight it varies from 5lbs. to 50lbs., and even more. Rough outside, it contains when ripe a mass of sticky fibres around yellowish sweet envelopes which surround the seeds. Both these sweet envelopes and the seeds are edible. The pulp possesses a delicious flavour, which is much liked once the objection to the peculiar penetrating smell which characterises them has been overcome. This smell can to a great extent be neutralised by throwing the sweet pulpy envelope into a bowl containing some water and salt. The seeds, which many prefer to the best chestnuts, may be eaten either boiled or roasted. They are oblong in shape, and about 1½ inches long.

The sometimes objectionable smell referred to is more perceptible in over-ripe fruit, and is much lessened by burying the fruit for a while.

In tropical countries a very sticky bird-lime is prepared from the milky juice of the tree, which is extracted by wounding the bark.

Very handsome cabinet work is made from the yellow satinlike wood.

Either for ornament or usefulness, or both, the Jack-fruit deserves a place in every tropical garden.

#### LITCHI (*Nephelium Litchi*).

A handsome evergreen tree, some 20 to 25 feet high, native of Southern China. The best sorts are propagated by grafting, seed-

ling, or layering. Extensively cultivated in India, Ceylon, and in the coastal lowlands of Mauritius, where the excellence of the fruit has marked for it a prominent place amongst the best tropical fruits grown. At the time of ripening the heavy clusters of crimson fruit form a startling contrast with the dark glossy foliage. The fruit, which is roundish conical, consists of a large, smooth, oval, brown stone, covered by a pulpy arillus of a nearly transparent white, like jelly; sweet, with a delicate sub-acid flavour. The whole is encased in a rough, crimson shell-like covering.

The sun-dried fruits are largely exported from Canton and Hong Kong, and can be seen in Chinese greengrocers' shops of Perth.

#### LONGAN (*Nephelium longanum*).

The tree is much like the litchi, but taller; it is also hardier, and can be raised true from seed. The fruit is not so rough externally as the litchi, and, like it, is contained in a shell-like covering; it is roundish in shape, with a round brown stone, covered by a pulpy arillus like the litchi, but not so palatable.

#### THE MANGO (*Mangifera indica*).

The mango, all the world over, is classed amongst the best of tropical fruits; few rival and none excel it. The tree is a handsome, large-spreading evergreen, which grows from 10 to 30 feet in height, and even more. It is a native of India, but is now widely cultivated all over the tropics, and even in many subtropical countries. The leaves are lanceolate, and the flowers in terminal panicles. In size, shape, colour, flavouring, and quality of flesh the fruit varies widely.

Its varieties range in weight from 2ozs. to 2lbs. each. In shape it is generally kidney-form, although some are roundish and flattened and others elongated and curved. The colour of the skin is generally green at first, although some are red or purple, and they assume, when ripe, a yellowish colour. Other varieties are mottled with various shades of red, while a few do not change colour at all in ripening. Between the skin and the kidney-shaped stone in the centre is the fleshy pulp, which is yellow, sweet, and luscious. The "tar and turpentine" flavour which some varieties are said to possess, is only applicable to inferior varieties. The better kinds have little or no fibre, and if they possess any trace of turpentine at all, it is not disparaging to the deliciousness of the flavour.

The list of varieties of mangoes would be a lengthy one. The Agri.-Horticultural Society of India publish a list of forty odd kinds, of which they sell grafts; forty varieties or more are known in Java; some thirty varieties or more are cultivated in Mauritius; while a great many are also known in the West Indies.

The mango does not reproduce true to name from seed, and, as it does not readily take the cleft graft, it is generally propa-

gated by inarching. Grafted mangoes come into bearing in about five years after planting out. Varieties highly praised are: The Alphonso mango of India, the August mango of Mauritius, the Strawberry, Carpenter, and a host of other good sorts which would prove a great acquisition to our North and North-West provinces.

The mango is not only eaten when ripe, but large quantities are used green for pickles, chutney, or served raw with salt, pepper, and vinegar. The natives of India also use the leaves for its medicinal virtues.

The trees grow luxuriantly in the Northern Territory and in Northern Queensland, and withstand the attacks of white ants fairly well, probably on account of the turpentine taste of the wood.

#### THE PAPAYA (*Carica papaya*).

A native of Central America, it has now reached every corner of the tropical world. Sometimes called pawpaw.

The tree, which is unisexual, consists of a soft-wooded trunk, smooth and without branches, reaching 10 to 15 feet in height. The male flowers are white and hang down in clusters, whereas the female flowers are large, yellow, and carried close to the main stem at the base of the leaves which are palmate, with long stalks, and carried at the top of the tree. As the tree grows another lot appears above with the broad leaves spread out like an umbrella on top.

The papaya trees are easily raised from seed, and, when strong enough, may be planted out. The first year they require a certain amount of protection in localities likely to be visited by frost. They bear within a year, and, as they are not long lived, they should be replaced every three or four years. Mr. G. C. Rose, of Parkfield, near Bunbury, states that they grew splendidly with him on the banks of the Fitzroy, West Kimberley, till the white ants ate them down.

Papayas will grow in almost any kind of land, but naturally prefer good soil. The seed should be sown in rich soil in a sheltered spot. The seedlings may be removed to their permanent positions when 6-9 inches high. Plant close—6ft. apart—which will allow for thinning out at the first flowering of the trees—10-15 months after planting—of those bearing long-panicle flowers, which are mostly male, the female flowers, if any on them, bearing poor fruit. When in Queensland I procured from Mr. Howard Newport, at Kamarunga, seeds of a superior variety of papaya from New Guinea, growing under the name of "New Era," which carries both male and female flowers on the same tree. The fruit is of exceptional size and quality. I distributed seeds amongst a number of settlers in Kimberley and along the North-West coast. Shade each

young seedling with a small leafy branch and give a light mulch of leaves or stable manure to retain moisture in the soil and keep the surface loose. Do not injure the stem when transplanting.

The female trees bear numbers of flowers close to the stems, at the axils of the leaves, and these require to be thinned out to give room to the set crowded fruit to develop. By means of "forced nourishment" it is said much benefit follows. Bore a hole into the trunk about 6in. from the ground, 1in. deep and of a diameter slightly larger than that of red rubber tubing. Fill a quart bottle half full of sugar and dissolve in water, connect the bottle with the hole in the tree by means of the red tubing. In 24 hours the tree will have absorbed the contents of the bottle.

Papayas, like Grenadillas, if carefully gathered and well packed in cases only holding one layer of fruit, should carry well to the Southern markets if sent in the cool chamber.

The papaya bears heavily from the first year. The fruit has the appearance of rock melons and is excellent eating and wholesome.

An acrid sap pervades the whole tree, and possesses marked digestive power for nitrogenous substances. In fact that property has been availed of in medicine, and papaine, the active principle, is used as a vegetable pepsin and as a vermifuge. The fruit is used in the tropics with benefit in cases of internal inflammation. In Mauritius, where the papaya grows to great perfection, this property is often availed of to turn tender, tough old roosters. They are simply wrapped up in papaya leaves and hung for a few hours under a papaya tree.

#### PINEAPPLE (*Ananas sativa*).

A native of tropical America. This plant has been successfully grown in countries situate 28deg. North and South of the line, wherever the conditions of moisture, shelter, and soil have favoured its growth.

With us it is susceptible of growing in the open air in proximity of the seaboard as far South as Champion Bay, provided the annual rainfall be supplemented by judicious irrigation. Beyond this limit its cultivation may be extended even farther South under the protection of sheds, as is done in Florida, but under such artificial conditions pineapple culture ceases to offer commercial possibilities, and can only be attempted by amateurs.

Too rich soil does not suit the pineapple. It is intolerant of wet and retentive clay soils. A deep free loam, permeable and fresh, with perfect drainage, and which at no time becomes waterlogged, is the ideal soil for the pineapple. When the ground is not naturally drained the plants are usually set in ridges. In Mauritius



Pineapple Plantation, Queensland, Northern Australia.





it is most successfully grown on friable volcanic soil. In other countries it does well on sandy soils, especially those of coralline formation, with a thin layer of vegetable mould on the surface.

The pineapple is a biennial plant, not unlike a miniature aloe, but the leaves are much thinner. Is seldom propagated from seeds, unless new varieties are desired. Most good pineapples, besides, are seedless, but seedling plants are generally very slow growers, and do not bear for 10 years or so.

The crowns or the tufts of leaves at the top of the fruit are sometimes grown, but they require two to five years to mature. For that reason the extensive propagation of this fruit is effected by means of slips and of suckers. The slips are produced from buds on the fruit stalks under the fruit. They are smaller than the suckers, but are more abundant. If it is intended to use them for planting, all but two are rubbed off; they are planted as quickly as possible after they mature, which takes place when the stem under the leaves turns brown. Slips fruit about 18 months after planting, and produce fine fruit; suckers, which spring from buds below the soil, fruit about a year to eighteen months after planting. Two or three are generally left on the plant, one of which replaces it after fruiting, the others being removed for further planting.

The plants are set in lines at distances of 5ft. x 2ft., if a horse-hoe is used, and 3ft. x 3ft. if manual labour is employed. These will number 4,356 and 4,840 plants to the acre respectively. and with proper treatment should give from 3,000 to 3,500 fruits at the end of two years. The sets or suckers should have their basal leaves trimmed, and the contracted hard buds by which they are attached to the parent plant partly cut off. They are firmly set into the ground to a depth of 3in. to 4in. Fertilisers are worked into the ground between the rows. The practice of broadcasting chemical fertilisers is injurious to the leaves, as the salts of ammonia and of potash so used exert a caustic effect. Weeds should be kept down. After some years, and unless the suckers or ratoons are largely removed, the beds become almost impenetrable. The period of usefulness of a plantation lasts from five to eight years.

When the fruit is marketed to long distances, it is cut before it is quite ripe, a portion of the stalk being left attached, or else the fruit will bleed. The crown is also left intact, and should not be trimmed, so as not to rob the fruit of its decorative appearance. The pines are packed in large crates, but its advisable to provide partitions in these crates, so as to separate fruit in lots of four to half a dozen each.

At present we annually import some £4,000 worth of this fruit and do not grow any.

The best varieties imported are the Smooth Cayenne, the Ripley, and the Queen.

Queensland growers get on an average for all grades, 3s. per dozen; Melbourne wholesale dealers, from 4s. upwards. This fruit is cheaper in the summer, and the price per case containing 12 to 15 is 4s. to 6s., and occasionally 10s. for choice fruit in Melbourne.

Taking the cost of a case of this fruit at 6s. Melbourne, 2s. freight, 1s. wharfage, inspection fee, handling and railage to Perth, making a total of 9s., or 9d. each, without counting waste and importer's profit, it is seen that good pineapples cannot be sold for less than 1s. each. At that price only the wealthy can afford to buy this fruit fresh.

The varieties grown are either spineless leaves or spiny leaves. Of the spineless-leaved pineapple, the most commonly grown is—

**THE SMOOTH-LEAVED CAYENNE** (syn. Giant Kew).—Leaves long and smooth, or with very few spines, broad, dark green; flowers purple; fruit very large, pyramidal, dark orange yellow; flesh pale yellow, rich, highly-flavoured; pips large, flat. Does not sucker so freely as other varieties. A very handsome fruit, weighing 6lbs. to 10lbs. An autumn and winter growing variety. Largely grown in the Azores for the purpose of supplying the English market during the winter and early spring months.

Of the spine-leaved kinds, some of the best are—

**BLACK JAMAICA** (syn. Black Spanish).—Leaves long and narrow, dark green, almost a blue purple in the centre. The leaves are hollow, not open and flattish. The leaves have little hooked prickles; not spines like the teeth of a saw, but set distinctly from each other. Flowers purple; fruit oval, somewhat pyramidal, dark green at first, and fit to eat before it shows any yellow or red; pips middle-sized, prominent; flesh firm, yellow, rich, juicy, and highly flavoured. Weight of fruit, from 4lbs. to 5lbs. Ripens in the winter.

**QUEEN**.—Leaves very short, broad, of a bluish green, very mealy; spines strong, set widely apart; flowers lilac; fruit cylindrical, of a rich deep yellow; pips middle sized, prominent; flesh pale yellow, juicy, sweet, rich. Best in summer and autumn.

**RIPLEY QUEEN**.—Of these there are two varieties—green and red. The Ripleys belong to the Queen varieties. Leaves green with purplish longitudinal streaks running up the centre. As the plant gets old and weak, the purple streaks become irregular, and the green of the leaf yellow. The spines are numerous.

**LADY BEATRICE LAMBTON**.—A pyramidal pineapple, very juicy, grown with marked success in the Cairns district, North Queensland.

In Cuba the pineapple is largely grown for export. The Red Spanish is nearly always planted as it is hardy and a good shipper.

Other kinds cultivated are Abbaka, Black Antigna, Long Green and Red Ceylon.

## FRUIT-DRYING

Is a valuable and expedient method of stopping physical and chemical changes and extending under a convenient form the sale and the uses of fruits and of vegetables.

In the height of the fruit season, much that should never be put on the market to compete with the higher-grade produce can with profit be disposed of as dried fruit.

It is not meant to infer that a high-class dried fruit can be manufactured out of an inferior sample, but rather that it may be more profitable to convert such produce into a more readily saleable article.

It may also happen that in the glutted market in the midst of the season even first-class fruits cannot be sold at a profit, and it then may be advantageous to hold them back and prepare them into some other commercial form.

Drying affords a cheap-and-ready way of converting into a commercial commodity (which may be stored and disposed of to the best advantage in due season) such quickly perishable products as ripe fruits.

To those situated in remote localities beyond easy distance of markets or of the highways leading thereto, drying also offers a convenient way of utilising their bulky and perishable crops.

Observation, experience, and such education as is conveyed by the mistakes of others have resulted in a variety of methods and practices being adopted when drying different fruits. The principles which underlie these methods are the same, but local convenience, the cheapening of the handling, and the ultimate appearance and commercial value of the products turned out have been the main causes of such modifications as the treatment of each kind of fruit suggests.

## RAISINS

is the name given grapes dried in the sun or by artificial evaporation. During that process the vine fruits lose a little over two-thirds of their weight, owing to the evaporation of the water they contain.

In practice, however, Lexias, Sultanas and currants which are run through the stemmer and the grader, where stalks and small unmarketable fruit are eliminated, show a bigger shrinkage in weight; an amount ranging from  $3\frac{1}{2}$  to 4 to 1, *i.e.*, it takes  $3\frac{1}{2}$  to 4 tons of the fresh fruit to produce 1 ton of marketable dried.

Three main types of raisins are made:—

1. The *Muscat* or Malaga type, of large size, which is again subdivided into Lexias or Pudding Raisins and Table Raisins.

2. The *Sultana* type—of medium size, amber colour, and seedless.
3. The *Currants*, or small size, dark coloured, seedless, made from the Black Corinth grape, and sometimes from the white Corinth.
4. The *Dried Grapes*, made occasionally from grapes, such as the Waltham Cross, Doradillas, but mostly from wine grapes, which, in Greece, Turkey, and some of the Mediterranean islands form an important industry. The product is exported to France, Germany, England, where it is turned into white wine, either consumed as such or turned into brandy.

#### PUDDING RAISINS OR LEXIAS.

The bulk of the raisins are of this class. The name *Lexia* (L. *Lixivium*) they owe to the fact that unlike Table Raisins they are dipped in a lye. The grapes used in the manufacture of these raisins are the Muscatel Gordo Blanco, the Muscat of Alexandria, and the seedless Sultana.

*Picking.*—The grapes should never be picked for drying before they are dead ripe.

The currant crop is ready for picking a fortnight before the Muscats, and the same trays answer for drying both crops, so that the advantage of growing them together is evident.

There are several ways of ascertaining whether the crop is fully ripe:—

(1.) By the colour, which, in the case of the Sultana and of the Muscatel Gordo Blanco, should be a bright amber, perfectly sweet, without a trace of acidity in any of the berries. (2.) By the saccharometer, which gives more accurate indications, as a bunch grown in the shade may be ripe and yet colourless. It is reckoned that the juice of the grape should contain at least 24 to 25 per cent. of grape sugar ( $13\frac{1}{2}^{\circ}$  Baumé) to produce a good raisin.

Pieces of stalks, dead leaves, also imperfectly ripe berries, which would dry brown instead of a bright colour, are removed.

*Dipping.*—The ripe grapes are usually picked in baskets. The baskets should not be piled on the top of each other, nor should their contents be dumped on to the ground. They are brought to the dipping tank and draining terrace where the grapes are placed in galvanised iron baskets or sieves, or in perforated kerosene tins; at least two such baskets are required, which are lowered into the dip and filled alternately. The lye tank may consist of any convenient open boiler, such as a washing boiler, or even a 200 or 400 gallon square iron tank cut in half and set in mortar over a fireplace.

The strength of the lye used varies. The stronger the lye the shorter the time the fruit is dipped.

Alkalies of known strength in water, brought up to the boil, are now generally used in preference to the old time rule of thumb mixture of ashes from vine prunings and powdered quicklime.

Thus, 1lb. caustic potash or caustic soda to 16 gallons of water is sometimes used, although many prefer a stronger lye made of 1lb. of caustic soda to 8 gallons of water, claiming that fruit quickly dipped retains a brighter colour when dried.

The strength of the lye having been settled, the solution is brought nearly to the boil, and all scum floating on the surface is skimmed off. Some of the least ripe grapes are then dipped for two or three seconds into the boiling liquid, and the result of the dip ascertained a few minutes later. The object of dipping is to make the drying process more active by dissolving or saponifying the waxy covering which constitutes the bloom, and opening up the pores on the skin, thereby allowing the quicker evaporation of the juices of the fruit. If as a result of the test on these more tender berries numerous small holes like pin-pricks show, the length of the dipping is sufficient, whilst, on the other hand, should the skin show cracks and slits, the time of immersion of the fruit in the lye should be shortened, or the strength of the lye itself should be reduced by means of a further addition of pure water.

The minimum time for dipping is two seconds, in the stronger lye, and the maximum 18 seconds in the weaker. Thickness of skin, stage of ripeness of skin, abundance of waxy bloom, and strength of the lye all govern the length of dipping, and this, as has been explained, can be adjusted by means of personal tests.

The strength of the lye must be kept up by the addition of the caustic potash or soda.

*Rinsing.*—After dipping, the galvanised iron baskets are allowed to drain for a minute or so, and are then plunged into clean, cold water, and emptied on the trays or on the racks to dry. Some do not rinse the fruit, and claim that the colour is then brighter.

*Sulphuring.*—After dipping and before drying, the fruit is often exposed to the bleaching action of sulphur fumes in order to obtain a bright amber-coloured sample. Trade requires this colour, and the process has little or nothing else to recommend it as the fruit is often over-sulphured and is rendered acid, heavy to digest, and much of the peculiar fruity aroma inherent to the fruit is more or less destroyed.

The extent of the sulphuring cannot be determined by any hard and fast rule, and must be adjusted by practice; but it is necessary that the several charges in the bleaching chamber should be exposed to the same amount of sulphuring, otherwise an uneven sample would result, and the value of the article would thereby be greatly affected.

A small sulphuring chamber may consist of a box large enough to cover several trays charged with fruit, or, preferably, of a larger chamber into which trollies laden with the fruit trays are wheeled and taken out again to make room for a fresh load. Mr. W. J. Allen, in New South Wales, recommends a room, 9ft. by 10ft. by 6ft. 6in., built of tongue and grooved boards, and put together with white lead. Any small cracks can be filled up with putty, or it can be papered inside. A room such as this requires about 2lb. of sulphur. Some push the bottom trays leaving a little room at the back, whilst the next tray is pushed a little farther, so that the interval be at the front, and so on until the last tray is put in. This arrangement favours the even distribution of the sulphur fumes, which are generated in a roaster set outside the box, with which it is in communication by means of a flue. A simple hole dug into the ground, and covered with an oil drum with a tin tube connecting it with the sulphuring box, will answer. The sulphur is set alight, the fumes allowed to enter the box, which has a hole at the top which can be either left open or shut by means of a sliding damper. When the fumes begin to issue from the box at the top, the damper is closed, and the fruit is allowed to remain for a few minutes immersed in the bleaching fumes. The trays should not be made of metal which is readily attacked by the sulphur fumes and turned into noxious sulphates. Highly bleached fruit is charged with sulphuric acid, which checks digestion and causes headaches. Ten to fifteen minutes is quite long enough. Sulphured fruit is prohibited from sale in several European countries.

*Drying.*—This is effected either through direct exposure to the rays of the sun, or where the sun's rays are not potent enough, through the artificial heat of specially-constructed evaporators.

At times the grapes are first half dried in the sun, and finished off in the evaporator, of which some good types, such as the "Vrai," and more recent types are well spoken of from the Murray River Irrigation Colonies.

In Western Australia, where a dry, sunny autumn may be relied upon with a fair amount of certainty, grapes, apricots, prunes, and such like fruit can be sun-dried with little trouble, and without entailing the extra cost of kiln drying.

Late-picked fruit, however, especially in the cooler districts of the State, might, in particularly early rainy seasons, be damaged when sun-dried; but, as a rule, all fruit ripening not later than the end of March may with safety be sun-dried, provided provision is made for covering the stacks of trays when the weather is unfavourable.

Around Malaga and the other famous raisin-producing districts of Spain, the raisins are exposed to dry on drying terraces, built on a slope, facing the hot sun. These terraces consist of brick wall quadrangles, filled in with earth, over which is spread several inches



The largest overhead trellis in Australia—"Belhus," on the Swan—Mr. Barrett-Lennard.

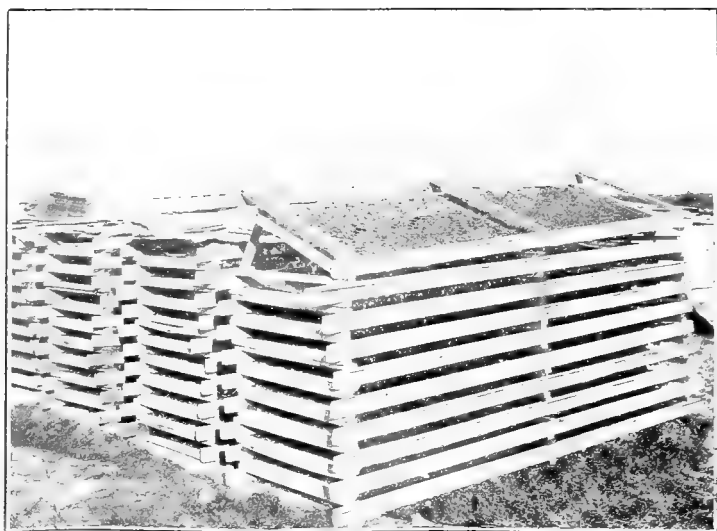

Stack of Raisin-drying wire trays.





of clean small gravel, on which the grapes are laid; on these they dry evenly, whereas if laid on the bare hard earth, one side is often dry, whilst the other remains moist.

The drying ground is, however, cumbersome and antiquated, and can with advantage be superseded by the drying tray or the drying racks. The trays are made of different sizes, but for the sake of convenient handling, trays 36 inches long and 24 inches wide are to be recommended.

They are either made of four 6in. matchboards, 3ft. long, held together by nailing head pieces of  $2\frac{1}{2}$ in. x lin. and 2ft. long at each end, or instead of matchboards, on which in damp weather the fruit mildews more than on lath trays, or of broad Oregon laths, set close, side by side, and which allow a free circulation of air. On the upper side a  $\frac{3}{4}$ in. rim is nailed all round the tray, and keeps the fruit from slipping off when turning it.

Over these trays the fruit is placed and exposed to the sun. When half dry they are turned. This is done by placing an empty tray upside down over the first tray to be turned, and swinging the lot over. The tray which had the fruit is then empty and ready for use in turning over the next tray in the row, and so on until they have all been turned over.

Of late years in Australia, these wooden trays have been discarded for the Raisin *drying racks*, made of a wooden framework, with wire netting shelves, over which the cut bunches of ripe grapes are placed to dry. As a protection against wet weather these drying racks generally carry a light galvanised iron roof. These racks are now superseded by the cheaper and more suitable *wire netting trays*. These consist of wooden battens, 3in. x lin. of desired lengths, 6 to 10ft. by 3ft. wide, for instance, set on edge, with inch battens nailed across to keep them apart,  $2\frac{1}{2}$  to 3 inches; over these wire netting,  $1\frac{1}{2}$ in. in mesh, is nailed. The currants are evenly spread over the netting, the muscats with the larger bunches cut into handy sizes, are laid over, and when one tray is full, another is placed on top, and also charged. They are thus built up into stacks of convenient height—3 to 5ft. The cross inch battens also provide an opening which permits the air to freely circulate over the currants, while the strong light does not affect the fruit, and a better colour results. In broken weather, wooden trays or loose sheets of galvanised iron are placed on top to throw off the rain. The orientation of the trays does not matter much, but if placed east and west, the influence of the sunlight would be less pronounced.

When drying sultanas or muscatels, it is advisable to give more space between the trays to avoid crushing and close contact, and for that purpose bricks or blocks of wood are placed between the trays to provide a greater interval.

When grapes or other fruit get wet whilst drying, they turn dark brown and are discoloured, and to prevent this, in case of rain or heavy dew at night, the trays are piled over one another to a height of three or four feet, and securely covered with a tarpaulin of roofing iron. When thus stacked, the thickness of the end cross-pieces prevents the fruit from getting crushed. After turning, the drying proceeds more rapidly, and the raisins should be watched to prevent them from becoming too dry.

Where a fairly heavy crop is gathered it is usual to stack the pile of trays laden with grape-fruit in process of drying under cover of permanent sheds, which afford protection against damage from a passing storm. The stacks are built in single or double rows, and in that case a passage way is provided between. The trays present over the racks the advantage of being movable, easy to load at the dipping tank, and to unload after drying, by the simple process of tipping upside down over a clean floor, or over spread canvas.

When sufficiently dry the raisins are removed from the trays. A ready method of ascertaining this is to pick up a few average berries and roll them gently between the finger and thumb. If a drop of liquid exudes at the stem end, the raisins require further drying; but if jelly only shows, the raisins are dry enough.

*Stemming.*—The next process consists in removing the stalks. These will be brittle if the raisins are taken up towards the afternoon, and will then break off easily. This can easily be done over a quarter-inch sieve, which will also let through some of the rubbish.

*Winnowing.*—This done, and before the stalks get limp, the loose berries are run through a winnowing machine, which separates a greater portion of the stalks and grades them in sizes.

*Sweat Box.*—The fruit must then be sweated for a fortnight or so before being packed and put away. Sweating is an operation which all dried fruit must undergo.

If the raisins on the trays are examined, part will be found dry enough, while part may be too dry and some not sufficiently cured. At this stage the sweat-box is found useful for equalising the sample and making the stems tough and ready for packing. The sweat-boxes are 8in. to 9in. deep, and contain about 1 cwt. of raisins. The boxes are only about two-thirds filled with raisins, and they should be stirred about every now and again until sufficiently dried. They may be used at other times for carrying grapes from the vineyard and other purposes.

*Packing.*—When the sweat-boxes are full they are put away, one on the top of another, for ten to twelve days, to sweat, after which they are taken to the packing room, which is provided with tables, scales, presses, and neat boxes of different sizes, holding 5lb., 10lb., 15lb., and 20lb., in layers of 5lb. each.

They are then placed in proper boxes and pressed hard by means of a lever or screw press so as to set them well in a mass, and exclude insects which prey upon dried fruit.

Where a community of vine-growers is engaged in the fruit drying, the work of processing the dried crop, cleaning, grading, and packing, is better and more expeditiously done at a central packing shed run on co-operative lines, where a more even and better marketable article is turned out.

*Cost of drying Raisins and Currants* from vine to sweat-boxes vary naturally with facilities for handling and management. Under ordinary conditions it is claimed to be about £5 per ton in the "Vrai evaporators" or some other efficient evaporator, to about £7 10s. when sun-dried in the River Murray district of Victoria and South Australia; this estimate being based on pre-war cost. Besides the certainty of drying in a good class of evaporator, there is also a lesser deterioration in weight caused by fermentation, and depreciation in value resulting from infection of flies, moths, dust, etc.

#### SEEDLESS RAISINS

are the produce of the Currant vines, the Sultana vines, or small and imperfectly developed Muscatel grapes, which now and then are found on muscatel bunches. When dried, these small raisins are separated in the grader, and sold as "seedless muscatels." For cooking purposes, seedless raisins are in better demand than the seeded lexias or pudding muscatels, and in order to meet the demand for that class of article, small and inexpensive raisin seeders are sold for a few shillings, which can be clamped to the corner of the kitchen or pantry table, and neatly extract the seeds from the raisins.

#### TABLE RAISINS.

The drying of Table raisins and of Currants is effected much after the fashion of pudding raisins, with the difference that they do not undergo the dipping process, which spoils the appearance and removes the bloom.

Great care should be taken in picking, for this reason, not to remove the bloom, which would spoil the appearance of the raisin. The bunch is handled by the stem, cut with a sharp knife, all imperfect berries, pieces of stalk, dead leaves removed, and then placed upon either shallow baskets or directly upon the trays right side up, *i.e.*, the side showing less of the stem. In large vineyards there is economy in placing the trays between the rows of vines and covering them at once with grapes, whereas on a small vineyard it may be convenient to take them all to the drying terrace.

The finest bunches having been carefully picked as described, they are simply put on wooden trays made 2ft. wide and 3ft. long.

If too large, they are not so convenient to handle when filled. Each tray receives from 20lb. to 30lb. of grapes, which should produce 5¾lb. to 9lb. of clean raisins. Sun drying, though longer, is preferable to the evaporator, and under favourable conditions it takes two to three weeks to cure good table raisins.

Upon the state of the weather and the size and degree of ripeness of the berries will the time required for drying depend. Rapid drying gives a hard and tough raisin, and should be avoided. At the end of eight to fourteen days, according to circumstances, the grapes being about two-thirds dry, are turned by placing an empty tray, as already described, on the top of a full one and reversed top to bottom. After turning the drying will proceed more rapidly, and the raisins should be watched to prevent them from becoming too dry.

In transferring from the trays into the sweat-box the raisins are slid off in the same position as when they lay on the tray. To prevent the stems getting entangled, two sheets of paper of the size of the box are put in at intervals as the box is being filled. The sorters have two or three sweat-boxes, and grade the raisins into first, second, and third quality.

The packing of table raisins is of paramount importance, as appearance considerably enhances the value. The flat boxes are artistically got up, and carefully lined with lace paper. Nice clusters of bunches of the same grade as the contents of the box are either flattened between the fingers or by passing through rollers and placed at the bottom of the box, which is then filled with as many grapes as it will hold; the lid is then placed on the top and nailed down after pressure has been applied. The box is then turned upside down and so labelled that what was the bottom now opens top. Facing plates are also used for the same purpose. They consist of a brass plate of the size of a box. In these plates are rows of small cup-like cavities, into each one of which a flattened raisin is set and lightly pressed, and loose raisins are carefully filled in on the top. After pressing, it is found that this top layer has retained its arrangement and is regularly faced.

The Australian Dried Fruits Association has declared prices for new season's currants, sultanas and lexias at a substantial advance on those of previous years, currants being 2d. per lb. dearer than last season, sultanas 2¾d. per lb., and lexias and seeded raisins 2½d. per lb. Single box rates compare with those for the preceding four seasons as under:—

	1916.	1917.	1918.	1919.	1920.
Currants—	d.	d.	d.	d.	d.
Four crown .. .. .	7¾	—	7¾	—	—
Three crown .. .. .	7½	6¾	7½	7½	9½
Two crown .. .. .	7¼	6½	7¼	7¼	9¼
One crown .. .. .	6¾	—	—	—	—

	1916.	1917.	1918.	1919.	1920.
Sultanas—	d.	d.	d.	d.	d.
Four crown . . . . .	8¾	8¼	8¾	9	—
Three crown . . . . .	8½	8	8½	8¾	11½
Two crown . . . . .	8¼	7¾	8¼	8½	11¼
One crown . . . . .	7¾	7½	7¾	8	10¾
Lexias—					
Five crown . . . . .	7¼	6¾	7¼	7½	10
Four crown . . . . .	7	6½	7	7¼	9¾

Lexias, 2 and 3 crown, for seeding only, are fixed at 9d., as against 6½d. last year, seeded raisins in cartons 11s. 6d. per dozen, against 9s., and loose 10¼d. per lb., against 7¾d. per lb.

This year's prices are abnormally high and not likely to be maintained, while it is reasonable to expect the prices ruling for the four previous seasons will be obtained for some years to come.

Favourable conditions of soil and climate, a liberal protective tariff, and an increasing demand for good grade raisins, sultanas and currants have made Raisin drying one of our most popular and profitable rural pursuits.

For the last five years the home prices of dried grape fruits have benefited: 1st by the disorganisation of the Mediterranean production of currants and raisins during the war; 2nd by the organisation of the industry which aimed at maintaining the price of the locally dried article by the compulsory exportation of a considerable portion of the crop. On account of the war the exported product found sales at a profitable price on barren markets; 3rd by the increased home consumption, which is estimated as follows:—

	Currants.	Sultanas.	Lexias.
	tons.	tons.	tons.
1914 . . . . .	3,000	3,900	1,250
1920 . . . . .	4,200	6,500	1,700

During the war, too, the importation of spirits from oversea had met with restrictions which have brought about an enormous increase in the value, and the substitution of Australian spirits for the imported article. Because of this, large quantities of grapes have been absorbed by the distilleries which otherwise would have been dealt with as dried fruit.

With the return of normal conditions, keener competition must be encountered on the export markets for the largely increased output of the considerable areas planted of late years with vines. Cost of production has also so much increased lately that it is essential, for vine growing to prosper, that larger outlets for the increasing crops be found.

## APRICOTS AND PEACHES

should be picked when fully ripe, but not overripe. The fruit should not be so soft as to be mushy, and when cut in halves with a sharp knife, should still retain their shape. The picking is often done by shaking the tree over spread canvas, but the better class of fruit is picked by hand. The fruit should be cut clean round, and the parts not torn apart. They are placed on the tray cut side uppermost, and should be taken to the sulphur room, described when dealing with the curing of Lexias Raisins, within an hour of being pitted, this is best done immediately after picking. It is estimated that in properly made sulphur rooms two to three pounds per 300 cubic feet capacity or 1lb. of sulphur per ton of fruit is sufficient for bleaching. About three to four hours is long enough to keep fruit in sulphur fumes; when the skin, unlike the pulp, is not bleached, the fruit curls up and looks small. During the sulphuring the cups fill with juice. Three or four days of sun-drying will be sufficient. If placed in the evaporator do not place the fruit in the hottest place to begin with, but start at that part which is 140 degrees and finish off at about 180 degrees. The fruit should not be dried hard enough to rattle on the trays. The proper stage is determined by handling the fruit, which should be soft and pliable to the touch, but not sticky. The fruit which is not quite dry, may at this stage be put on other trays for a few hours to complete the drying. The dried fruit having been taken from the trays, is put into clean calico bags and tied up securely to keep out moths. Small and inferior fruit is graded off, and tied in separate bags. These bags are placed in a cool, dry place, or else the fruit lose in weight and deteriorate. After sweating, if it is intended to box it, the fruit is graded and packed. A layer of fruit, flattened between the fingers or run through a clothes wringer, is placed at the bottom, cup-side down, the box is well filled, and pressure is applied. When the box is taken up and dressed, it is so done that, when opening what was the bottom becomes top.

*Moth infected* fruit is cleaned by dipping into boiling water for a few seconds and spread on trays and sun-dried for a few hours. Fruit so dipped will not keep its colour long, and should be consumed speedily.

The most suitable peaches for drying are Freestone, with a firm, yellow flesh, above medium size.

Peaches are dried either peeled or unpeeled. On account of the extra cost, peeling is generally dispensed with. A paring knife is used for peeling, and the knife for pitting Clingstone peaches.

The pit of Clingstone peaches is best removed with a knife, known as the Tarlton knife, such as is represented in the accompanying figure. It consists of a strong blade, with a short U-shaped

blade at the point. Unlike the spoon-shaped knife, which can only be used on soft fruit, it answers for both soft or firm fruit.

Like apricots, peaches after being cut in half are placed on trays, with the cut side up and fumigated for two hours only, the cup filling with juice, and then dried in the sun or the evaporator

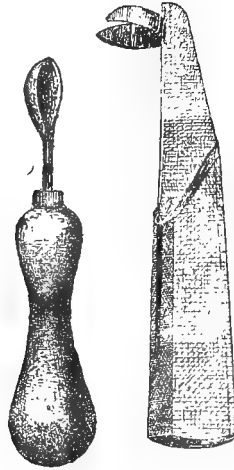

Knives for pitting Clingstone Peaches and soft fruit.

at the same temperature as the apricot. The drying is stopped while the fruit is quite pliable, when it is tied in calico bags and stored in cool, dry places, until ready to pack.

It takes 5lbs. of apricots, 4 or 5lbs. of dry fleshed peaches, and 5 to 7lbs. of more juicy peaches to 1lb. of dried fruit.

#### PRUNES AND PLUMS.

Plums are dried for stewing, they are cut open and pitted. Prunes are dried with the stone. Being a fruit of firm texture and not easily bruised, the labour of hand-picking is generally dispensed with.

The fruit is allowed to hang until dead ripe and they fall from the trees, when these are lightly shaken; the last crop has to be gathered by hand, and is generally used for a second quality.

They are graded before drying, either in some home-made grader, consisting of a long chute with three different sizes of wire screen on it, or they run through some grading machine of which several patterns are used. Unless properly graded, of the one size for each

tray, they dry unevenly, some being over-dried and others not dried enough. They are then dipped, as explained above, for three to 10 seconds in a lye brought up to the boil, containing 1lb. of caustic soda to 10 gallons of water. Immediately after the dipped fruit is plunged in fresh, cold water, so as to rinse it, the water being changed freely. Should the lye take off the skin, shorten the time of dipping slightly. It is then spread on trays, and in the case of light coloured prunes subjected to the action of sulphur fumes, just long enough to set the colour. Drying takes place in the sun or the evaporator; when exposed to the sun, according to the weather and location, it takes seven to 14 days to dry. If kiln-dried the operation is done in as many hours. The operation being done in three successive periods. The first two gradually dry the fruit, the last finishes the work and puts the gloss on.

The first "cooking" is at a temperature of 113° to 122° F. (45° to 50° C.), during which the fruit loses much of its water. If the heat is too great at this stage there will be expansion and bursting and dripping of fruit juice. After each cooking the prunes are simply rolled over the trays without handling the fruit. When cold, the trays are returned to the oven or evaporator and exposed to a temperature of 140° to 160° F. (60° to 71° C.), and in the third cooking to a temperature of 176° to 194° F. (80° to 90° C.), or even slightly higher.

Careful watching is required during the third heating to guard against the puffing and burning of the fruit. While still pliable the fruit is placed in sweat-boxes to even up, and left there for a couple of weeks, the fruit being frequently turned. Table prunes receive the "glossing" by dipping the dried fruit in hot syrup or in hot water with a small amount of glycerine added (1lb. to 20 gallons). This hot dip also kills insect's eggs. After the fruit has sufficiently dried from this dipping it is packed in boxes or jars and pressed. Three pounds of fresh prunes make one of dry. The price is regulated according to size, which range from 40, 50, 60, and up to 100 to the pound.

#### APPLES AND PEARS

should be more heavily sulphured than other fruit but not to excess, and dried as soon as pared and quartered. A better device is to cut the apples into rings with an apple parer. This machine also takes out the core which, boiled down with the skins, makes a jelly. A light-coloured article is preferred by the trade. In an evaporator kept at a temperature of 140° to 160° F., the drying is done in six to eight hours, and placed in sweat-boxes for a few days to even up, when it is tied in calico bags away from moths until ready for packing.



The yield of dried apples evaporated to a water content of 25 per cent., varies from 12lb. to 16lb. per 100lb. of fresh fruit, the sweeter autumn apples yielding better than the summer varieties, as a class low in total solids and in sugar.

When sufficiently dried for the sweat-box the fruit still contains more moisture than the finished article is to have. The slices should be pliable; when fresh cut no moisture can be pressed out, but they should be slightly sticky, and a handful of slices pressed into a ball in the hand should separate at once when released.

### FIGS

are picked when quite ripe, and when they commence to shrivel; the stalk should be left on them. The practice is to shake the branches vigorously; the figs are placed in perforated buckets and dipped up and down in a solution, brought up to boiling point, of salt, 3oz. to each gallon of water. This cleans the figs, hastens the drying, and softens the skin. After dipping they are spread on trays in single layers, the eye pointing up to prevent the syrup treaceling out during the first day or two of drying. They do not dry very evenly, and after exposure to the sun for six to ten days, during which they are turned once, the dry ones are removed, and those not yet ready allowed to remain longer.

Black figs are not sulphured, whereas white ones are improved in colour by bleaching. If too syrupy inside, and when the juice oozes at the eye, as occurs with some varieties, the eye is slightly raised for a day or two until the juice thickens. Figs should not be dried too hard; this is the cause of tough skins. If on examination no juice oozes out of the eye, and the fruit has a slightly leathery feeling, it is ready to go into the sweat-box, where it is turned over every few days, the skin becoming moist and pliable during the curing process. After coming out of the sweating boxes, after 10 to 12 days, and before packing, they are softened by dipping into boiling brine or hot syrup. A 2½ per cent. solution of salt, or 4oz. to the gallon of water; the over-dried figs or "floaters" being removed, the remainder being placed on trays a couple of inches deep and dried for a day or so. Previous to packing into boxes, neatly lined with paraffin paper, they are sorted, moulded under a screw press, and packed in layers with stalks facing alternately all one way and then the reverse. Pressure is applied to keep out insects and prevent the fruit drying excessively. Three to four lbs. of ripe figs yield one of dry.

Thorough cultivation, manuring with potassic and phosphatic and lime fertilisers, and, where necessary, one irrigation a month before the fruit ripens, ensure finer fruit.

Sometimes dipping is dispensed with, and the fruit dried with the bloom on; the operation then takes longer.

## DRYING VEGETABLES.

If fruit drying is, under the influence of West Australian autumnal climate, susceptible of being profitably carried out in the sun, the use of evaporators utilising direct fire heat should in many instances prove of great value to the market gardener. Tons of vegetables at periods of glut are hardly worth picking, packing, and forwarding long distances from the gardens in moister coastal districts to the distant inland, arid centres of population. In many parts of the Eastern Goldfields fresh vegetables are never seen, and an important field is yet open to our enterprising vegetable growers in catering for those centres, and supplying them with vegetables differing from the fresh article by being simply deprived of its watery portions, which amounts, according to kinds, from three-fourths to nine-tenths of the weight of the vegetables.

In the first instance, surplus vegetables thus treated, would not be wasted and regarded by the grower as a loss of so much invested capital. They could be treated at any time of the year. The cost of dehydrating should be more than recouped by the very material reduction in carting and in railway freight; a perishable article subject to quick decay could be kept almost indefinitely and be sent over long journeys, when it could be used in small quantities at a time, and as required, and preserve unimpaired to the very last its taste and its succulent and refreshing, wholesome properties. When required for use it is only washed, then soaked for 12 to 24 hours in four to six times its weight of water, and then cooked as desired.

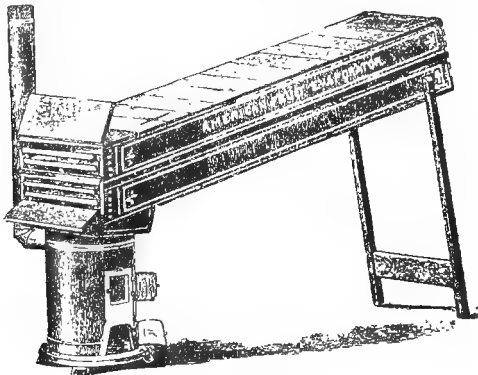

Fruit Evaporator.

Of evaporators a great many patterns are made; some horizontal, others upright. The charge is fed from underneath and the finished trays removed from the top.

A handy portable evaporator is constructed by Metters, Ltd., of Perth, and the trade also offers numerous other designs of fruit and vegetable dehydrators. The principle which underlies their construction is that the heat is made to circulate amongst the trays as rapidly as possible, and finally escapes through a flue at the top, carrying off with it the watery constituents of the fruit or vegetables. Provision is made for opening the evaporator and inspecting the progress of the drying. From the evaporator the goods are removed to a moth-proof chamber, where they are left to sweat, and are finally placed in suitable packages for marketing.

The "Vrai" evaporators manufactured at Torrensville, in South Australia, in standardised 9ft. room, cost £400 to £700 and £1,060, the patentees reserving a royalty of a  $\frac{1}{4}$ d. per lb. of dried fruit.

Other evaporators claiming more or less distinct features are also in use on the Murray irrigation colonies in Eastern Australia. Dehydrators were much used during the war for drying vegetables, fish, and other produce for use by the armies and the navy.

### FRUIT CANDYING

is the process by means of which the juice is extracted from the fruit and replaced with sugar syrup, which, upon hardening, preserves the fruit from decay, and at the same time retains the natural shape of the fruit.

After the preliminary candying process has been effected the confectionery is ready to be either glacé or crystallised. Glacé fruit is prepared by dipping the candied fruit in thick sugar syrup and leaving it to dry and harden quickly in the open air. The sugar thus forms a glaze on the fruit, which gives it its name. If it is to be crystallised, the fruit, prepared as described below, is dipped into the same kind of syrup and then removed and allowed to dry slowly in a room at a heat of 90° to 100° F., when the sugar appears in small crystals on its surface.

The method of fruit candying is clearly outlined in one of the U.S. Consul's Reports on—

#### CANDIED CITRON AND LEMON PEEL.

The industry is very well adapted to the Australian States, where all the material essential—fruit, sugar, and fuel—required is raised and produced.

"Leghorn, in Italy.—The fruit and every ingredient and article necessary to the preparation of the candied peel come from abroad. The fruit of the best quality comes from Corsica; Egypt furnishes the sugar, Great Britain provides the fuel, Trieste and distant provinces of Italy contribute a portion of the raw product and wood for the boxes in which the peel is exported. The province of Leghorn provides nothing but the labour necessary for the manufacture.

"Nor is this industry, the Consular Report says, one which has fallen into Livornese hands from any specially acquired local

handicraft or skill. It is mainly supported by the large drawback granted by the Italian Government upon the duty paid on the chief and dearest ingredient in the manufacture: sugar. The customs tariff in force imposes a duty of 76.75 lire (lire = 10d.) upon 100 kilos (2 cwt.) of the sugar used; but grants a drawback of 69.50 lire upon 100 kilos of the exported article. Without this large measure of support the industry would immediately and wholly collapse.

"The citrons are shipped to the factories in casks, and, when the distance is not considerable, in sacks, but usually in hogsheads filled with brine. In preparation for shipment in brine, the citrons or lemons are cut in halves and salted—100lbs. of salt to the cask—and the cask is then filled up with salt water. They are left in soak for two or three weeks, when the casks are opened and the citrons weighed; 770lbs. of citrons are allowed to each cask; seawater and a little salt are added, and the cask is ready for exportation. A small auger-hole in the bung allows the gas produced in the cask to escape. Salted citrons and lemons sell for about \$10 to \$12 a cask; when arrived at the factory they are removed from their packing, and the pulp is separated from the rind. This is done by women, who, seated around a large vessel, take out the fruit, skilfully gouge out the inside with a few rapid motions of the forefinger and thumb, and, throwing this aside, place the rind unbroken in a vessel alongside them.

"The next process consists in ridding the rind of the salt by maceration in fresh cold water for two or three days, the water being changed occasionally. Then the rinds are boiled for one to two hours to soften them and prepare them to absorb the syrup, and also to rid them completely of any trace of salt. At this stage they become of a green colour.

"They are next put in a syrup for a slow absorption of sugar. This occupies no less than eight days, as this absorption of sugar, to be complete, must be slow and gradual. The syrup is at first weak. To every kilogramme (2lbs.) of fruit a syrup is added made of 1lb. of sugar and one litre (quart) of water.

"The fruit has now passed into the saturating room, where, on every side, are to be seen long rows of immense earthenware vessels of about 4ft. high and 2½ft. in extreme diameter, in outline roughly resembling the famed Etruscan jar, but with a girth altogether out of proportion to their height, and with very short neck and large open mouth. All the vessels are filled to their brims with citron, lemon, or orange peel in every stage of absorption, *i.e.*, steeped in sugar syrup of, roughly speaking, eight different degrees of strength. I have said before this is a process which occupies almost always eight days; and, as the syrup in each jar is changed every day, we may divide the mass of vessels before us into groups of eight. Take one group of this number and we

are able to follow the fruit completely through this stage of its treatment. With vessels of such great size and weight, holding at least half a ton of fruit and pulp, it is clearly easier to deal with the syrup than the fruit. To take the fruit out of one solution and to place it in the next stronger, and so on throughout the series, would be a toilsome process, and one, moreover, injurious to the fruit. In each of these jars, therefore, is fixed a wooden well, into which a simple hand-suction pump being introduced, the syrup is pumped from each jar daily into the adjoining one.

“How is the relative strength in each jar regulated?” is the next question. “The fruit itself does that,” is the foreman’s reply; and this becomes clear from the following explanation: Number your jars from 1 to 8 respectively; and assume No. 1 to be that which has just been filled with peel brought straight from the boiler, in which it has been deprived of the last trace of salt, and No. 8 to contain that which, having passed through every stage of absorption but the last, is now steeped in the freshly-prepared and therefore the strongest solution of syrup used in this stage. ‘We prepare daily a syrup of the strength of 30deg., measured by the “provino,” a graduated test for measuring the density of the syrup,’ continued the foreman; ‘and that is poured upon the fruit in jar No. 8. To-morrow the syrup from this jar, weakened by the absorption from it by the fruit of a certain proportion of sugar, will be pumped into jar No. 7, and so on daily through the series. Thus, No. 1, containing the fruit itself, regulates the strength of the syrup, as I said.’ ‘But if the syrup has lost all its strength before the seventh day, on arrival at No. 1?’ we ask. ‘Care must be taken to prevent that, by constant testing by the “provino,”’ is the reply, ‘and, if that is found to be the case, a little stronger syrup must be added to the jar.’

“A slight fermentation next takes place in most of the jars; but this, so far from being harmful, is regarded as necessary. Of course, it must not be allowed to go too far. There is yet another stage, and that, perhaps, the most important through which the peel has to pass before it can be pronounced sufficiently saturated with sugar. It is now boiled in a still stronger syrup, of a density of 40deg., by the testing tube; and this is done in large copper vessels over a slow coke fire—care being taken to prevent the peel from adhering to the side of the vessel by gentle stirring with a long paddle-shaped ladle. The second boiling will occupy about an hour. Taken off the fire, the vessels are carried to a large wooden trough, over which is spread a coarse, open wire netting. The contents are poured over this, and the peel distributed over the surface of the netting; so that the syrup, now thickened to the consistency of treacle, may drain off the surface of the peel into the trough below. The peel has now taken up as much sugar as is necessary.

"Now comes the final process, the true candying of the covering of the surface of the peel with the layer of sugar crystals which is seen upon candied fruits. To effect this a quantity of crystallised sugar—in Leghorn the same quality is used as is employed in the preparation of the syrup—is just dissolved in a little water; in this the now dried peel, taken off the wire netting, is immersed. The same copper vessels are used; and the mixture is again boiled over a slow fire. A short boiling will suffice for this, the last process, for the little water will be quickly driven off, and the sugar upon cooling will form its natural crystal over the surface of the fruit. Poured off from these vessels, it is again dried upon the surface of the wire netting, as before described. The candying is now complete; and the candied peel is ready for the packing room, to which it is carried off in shallow baskets.

"In the packing-room may be seen hundreds of boxes of oval shape, or, if I may so speak, of rectangular shape with rounded corners, and of different sizes; for each country prefers its boxes to be of a particular weight, Hamburg taking the largest, of 15 and 30 kilos; the United States of America preferring smaller, of 10 and 12 kilos; Britain taking the smallest, of five kilos, and one containing about seven English pounds. The wood of which the tops and bottoms of these boxes are made comes to us in thin planks from Trieste; and a skilful packing is generally done by women—the boxes being lined with white paper. They are then packed in cases of 100 kilos, 10 of the smaller American boxes filling a case. The candied peel is now ready for export."

The proportion of sugar used in the candying process is 80 per cent.—*i.e.*, 80lbs. sugar for 100lbs. fruit. The wholesale prices of the best candied fruit fluctuate considerably, from 6½d. to 9d. per lb., early in the autumn.

#### OTHER FRUITS

are candied pretty much after the same method, with this exception, that they are not put in brine, the object of which is to extract the bitterness peculiar to citrus fruits.

They are, however, carefully assorted in respect to size and uniform degrees of ripeness, as different fruit require treatment with syrups of different strength. The fat, fleshy fruits absorb the sugar with greater difficulty than thinner and smaller fruit.

Apples are not generally candied.

Pears, pineapples, and quinces are pared, citrons are cut into quarters and soaked in brine, and the "pits" of apricots, cherries, and peaches are carefully removed.

Thus prepared, the fruit is "blanched" or immersed in boiling water, which quickly penetrates the pulp, dissolving and diluting

the juice when the fruit is taken from the water and drained, leaving only the solid portion of the pulp intact. Skill is required for this process, as the pulp may be either overcooked or left too dry, preventing the perfect absorption of the sugar afterwards and causing subsequent fermentation.

After being thus scalded some fruits—apricots, for example, are again sorted into two or three classes, according to the degree of softness that has been produced, as they take up the sugar differently, the softer the fruit the stronger the syrup required for its preservation.

For the same reason, each of the different varieties of fruit requires a syrup of corresponding strength.

Pears, citrons, and pineapples, which remain hard and firm, take best a syrup having a density of from 18deg. to 25deg. Baumé; while apricots, plums, and figs are treated with syrup which weighs 30deg. to 42deg. B.

The syrup penetrates the pulp and gradually withdraws and replaces the remaining fruity juice, which, as it exudes and mingles with the transparent fluid, produces a certain filmy or cloudy appearance, which marks the commencement of fermentation. When this occurs, the vessel is placed over the fire and heated to 212deg. F., which kills the germs of fermentation, the impurities rising at the same time to the surface, when they can be removed by skimming. This process takes five to six weeks, during which time the heating is done two or three times. This done, the fruit is taken out, washed in pure water to remove the flaky particles that adhere, and is then submitted to the finishing “glacé” or “crystallisé” processes, after which they will bear transportation to any climate, and will keep firm and unchanged for years. It is packed in light wooden or cardboard boxes, and may be shipped in cases containing several hundred pounds each.

Such fruit sells wholesale for about 1s. lb., the cost of fruit and of the processing amounting to about 10d. lb. The retail price is 2s. to 3s. per lb. It takes 1 to 1½lbs. of sugar to 1lb. of fruit.

### CANNING AND FRUIT PULP.

This method of preserving edibles is modern in its industrial application, and is another illustration of some of Pasteur’s researches and investigations regarding the cause of fermentation.

As demonstrated by Pasteur, fermentation is the result of peculiar decomposition set up by micro-organisms of definite sorts.

In order to accomplish their work, these micro-organisms need, in the first instance, proper food; and, secondly, sufficient moisture; and, thirdly, warmth.

By the abstraction of moisture, as occurs during the process of fruit drying or of dessication of meat, one of those essentials is removed, fermentation or putrefaction cannot take place, and the articles of food is preserved against decomposition. On the other hand, if warmth is needed for the satisfactory evolution and working of those micro-organisms which cause fermentation or decomposition, it may either be insufficient or too cold, and then they remain inactive or dormant, or it may be in excess or too hot, and in that case their life is suspended or destroyed.

On these principles are based the keeping of meat, milk, butter, etc., by freezing, or of the sterilising of wine, with a view to their better keeping, which is effected by heating it up rapidly to 150° F. (65° C.), and also rapidly cooling it to the normal temperature. This process is known as "pasteurisation" after the name of the scientist who first suggested it and proved its efficiency.

By an application of the same process, we find, in canning, a cheap, ready, and practical way of destroying germs of decomposition from the articles of food we seek to preserve. How to successfully achieve that end without materially destroying the natural flavour and appearance of the goods to be preserved, constitute the art of canning.

A little experience will in this matter bring proficiency to the operator, and enable one to save much fruit that would otherwise be lost.

The materials used for canning are much too numerous to enumerate, but amongst the more commonly used are—fish, oysters, meat, condensed milk, cream, asparagus, green peas, sweet corn, tomatoes; and amongst fruit—apricots, cherries, gooseberries, grapes, nectarines, peaches, pears, plums, pineapples, quinces, guavas, and many other fruits which endure stewing without injury to flavour or to the form of the fruit.

Oranges, for instances, are not suitable for canning, on account of the peculiar bitter flavour they develop on cooking; while, on the other hand, sour or cooking apples are also unsuitable, as they cook into a pulp, and lose both their flavour and appearance on cooking.

Besides preservation of fruit by drying or by sterilising by the application of heat, there is also a third way of preventing fermentation, and that is by heavy additions of spirits or of sugar; but these are unsuited for the purpose we have in view, and are too expensive.

All three are legitimate ways of preserving fruit almost indefinitely. Another way also exists which is not lawful nor wholesome, and consists in the use of antiseptics which are antagonistic to the development of ferments and other micro-organisms, such as salicylic acid, etc. These substances are all noxious poisons,



which paralyse the digestion and injuriously affect the health of the consumer. They are only permissible when preserving fruit specimens for show purposes.

### HOUSEHOLD CANNING.

No detailed account will be given in this chapter of the process of factory canning, as this constitutes an industry in itself, and requires a certain outlay of capital which is suggestive of the fact that whoever goes in extensively for it must previously have made himself familiar with the *modus operandi* of the business.

In every household, however, it is not only quite possible but very easy to preserve, in seasons of abundance, all the fruit likely to be required during the off-season; and for this purpose all the outfit that is required merely consists of suitable jars or cans, and of the ordinary cooking utensils. Soldered tin cans are not to be recommended, as it may happen that the acid of the fruit will react on the solder and generate a toxic soluble substance injurious to health. Special canning glass jars, hermetically sealed, are, however, easily obtainable at a reasonable rate, and last indefinitely, until broken. One of the best is Mason's or "lightning" jars, which are made to hold a pint, a quart, or two quarts of fruit.

The fruit for canning must be of suitable kind; it must not be under ripe, over-ripe, or bruised; it must be graded according to size. Always keep the fruit in water, which cleanses it, prevents bruising, and, when cut open, preserves the natural colour.

In order to execute the filling neatly, a tin funnel with a very wide tube, slightly smaller than the diameter of the neck of the jar, into which it fits easily, is found very convenient, but is not indispensable.

Only the very best fruit is worth the trouble of canning; and all over-ripe, specked, or blemished fruit should be rejected or turned into jam. The fruit should be canned as soon as possible after gathering, and while still fresh, different fruit requiring different preparation.

Pears, peaches, and apricots are halved for convenience in cooking, although, whenever possible, a whole fruit will, as a rule, be more attractive to the look. A better method than paring peaches is to put a dozen or more at a time in a netting bag, and dip them for a few seconds into a kettle of boiling, weak lye. The fur is by this method easily rubbed off by wiping with a towel.

A little sugar having been added to the fruit and water, the operation of cooking begins, and varies according to the sort of

fruit. The following table, taken from a paper by Mr. E. Shelton, Instructor in Agriculture, Queensland, will prove useful:—

	Time of Cooking.	Quantity of Sugar to 1 Quart.
Pears (halved) ..	20 minutes ..	6 ounces
Peaches (halved) ..	8 " ..	4 "
Peaches (whole) ..	15 " ..	4 "
Apricots ..	15 " ..	4 "
Quinces (sliced) ..	15 " ..	10 "
Gooseberries ..	8 " ..	8 "
Plums ..	10 " ..	8 "
Cherries ..	5 " ..	6 "
Tomatoes ..	20 " ..	None

The fruit having been picked, halved, and pared, as the case may be, is neatly packed into the glass jars. The jars are then filled with thin, clear syrup made of white sugar, in the proportions given above, or, roughly speaking, by boiling one cup of sugar in one quart of water; this will give sufficient syrup for two quart jars. The syrup is used only to make the fruit palatable, and not for its preserving effect.

Place the jar in a boiler of tepid water reaching to within an inch of the top, and on a few nails or wooden racks with holes bored through. Screw on the stoppers loosely without rubber; cover the boiler, and boil till the fruit is done. A lower degree than 212° F. is unreliable; but this boiling should not be unduly carried on. Have some syrup ready on the stove for filling up the jars. When done, remove the jar from the hot water, put it in a place out of the reach of draughts of cold air, on a folded wet towel, so as to completely fill the hollow in the bottom of the jar, and thus ward against breakage; fill to the top with the hot syrup, wipe off the neck, put on the rubber, screw down the cover tightly; invert each can or jar, to make sure that there is no leakage and that no air can get in.

If there is a leakage, remove the cover, refill with syrup, try another rubber, and cover if still hot; if cool, heat again as already explained. Thus prepared, fruit will keep indefinitely. Glass jars containing fruit should either be put away for keeping into a dark room or be wrapped up in paper so as to exclude light, which has a deleterious chemical effect on the fruit, causing it to turn dark in colour.

#### CANNING IN FACTORY.

The following account of operations in one of the large Californian factories is taken from *Pacific Rural Press*:—"The fruit is pared and cored, and then washed in large troughs of clean water. Then each can is crowded full and marked with the grade of

the fruit to which it belongs. The cans up to this point have the large circular opening in the top, through which they are filled. They are then placed in racks holding several dozens, the racks being mounted on cars which bring them to the right height for convenient handling. They are then wheeled to the syrup tank and filled with syrup, about 300 to 350 pounds of sugar being used to a ton of peaches. The little caps to cover the circular openings, each cap with a small hole in the centre, are next soldered on with an apparatus by which a large number are handled in a minute. The truck on which stands the rack is then passed on to a tank full of boiling water, in which the rack, cans, and all are immersed. The hole in the cap is so small that no water enters, and none of the syrup comes out. Next, the rack full of cans is replaced on the truck and passed on to the second solderers, who deftly deposit a drop of solder on the hole in the cap. To make sure that no germs of decomposition are left within, the cans are again immersed in boiling water, and are then ready for packing, in which is included the placing of the proper label and boxing. The cans are made by machinery in the upper storey of the building, and come rolling down in a steady stream during working hours along a railway made for that purpose."

#### PULPING FRUIT.

Apart from fruit-canning, which needs to be done with a considerable amount of neatness, and requires a certain skill to be successfully carried out, a large number of the varieties of fruits cultivated in our orchards are not adapted for the purpose of canning.

Pulping fruit does not present the same difficulties. The principles of canning apply broadly to this method of utilising our fruit, but the operations of pulping are, in the main, more within the means of the majority of fruitgrowers than is fruit-canning properly speaking.

For pulping, the fruit is picked in approximately the same condition as for canning—firm and sweet, although the over-ripe fruit may be used as well.

No sugar is required. The stone fruits are pitted and set to cook in a copper boiler, or preferably in a steam-jacketed pan. The object of this cooking is to kill all germs of decomposition, the time required varying from 25 to 35 minutes. The whole mass is kept continuously stirred to prevent caking and burning, which would materially damage the quality of the pulp.

Immediately the pulp is cooked, the fire is drawn out or the steam shut off, and the pulp is run or ladled into tins of recognised size if for export.

These tins are cylindrical,  $5\frac{3}{4}$  to 6 inches in diameter, and 10 inches deep; they hold 10lbs. Fruit pulp is shipped from the South of France and Italy in packages of that size, 10 tins going to a case, which is reported to hold 100lbs. net.

Occasionally, the fruit to be pulped, instead of being stirred and mashed in a cauldron or a basin, is halved and packed in tins, which are closed, then punctured and immersed in water to within an inch or so of the top, cooked for 20 minutes, when the tins are sealed. Fruit pulp done this way has a better appearance and bring a better price.

For home use or for other markets, instead of the 10lb. tin, the large four-gallon tin, similar in shape and size with the ordinary kerosene tin, is used. When filled it holds 45lbs. of pulp. This package should be made of a heavier gauge tin than the kerosene tin, and thus guard against leakage caused by rough handling during transit.

The filling of the tins is done in the case of small fruit through a good-sized funnel set over a hole three inches in diameter punched into the top. If apricots and such like are tinned, they are ladled in.

To tomato pulp add a little salt to taste, or a mixture of salt and sugar in the proportion of 2 to 1. Two level teaspoonfuls of this mixture is added to each 2lb. can. Select firm, red tomatoes of uniform size. If it is desired to peel them, dip the tomatoes for half a minute in boiling water and peel promptly, use a slender pointed knife to cut the core, without cutting into the seed cells.

Some pulp settles down considerably when tinned. Should this occur, the empty space should be filled with scalded pulp. A small disc of tin, known as a stud, is then soldered over the hole, with a small vent-hole left open. The tins are then treated like canned fruit, and placed in a hot water bath until the temperature right through the mass reaches over  $180^{\circ}$  F. ( $82^{\circ}$  C.), so as to make sure that all germs are destroyed. This done, a drop of solder closes the vent-hole. If the operation has been successfully done there is no air inside, and on cooling a vacuum is created, which causes a contraction, shown by a comparison of the sides and ends. If, on the other hand, the mass has not been thoroughly sterilised, or if germs have got access to it before soldering the cover, fermentations will before long set in, which will be accompanied by evolutions of gases inside, and the ends as well as the sides of the tin will bulge out.

Should this happen, the "blown" tins are placed once again into the hot water bath, a hole is punched on the top to permit the escape of gas, and the temperature of the whole mass raised once more to  $180^{\circ}$  F., when the punctured hole is closed.

Freshly-filled tins should be kept under observation for a fortnight or so before being encased, and as a further precaution the tins are often tested.

This is done by immersing them for a few minutes into hot water. The air inside thus expands, and should the least hole exist its presence will be revealed by a stream of small air bubbles.

It is thus seen that fruit pulp affords a simple and ready means of storing until needed, all the out-of-season fruit we require for jam-making, marketing the balance at a time when the market is not glutted with the particular fruit thus preserved.

One ton of apricots makes one ton of pulp, the water added making up the weight of the pits removed.

For converting into jam, about  $\frac{3}{4}$  lb. of sugar is added to every pound of pulp and the mass boiled for about 30 minutes.

### JELLIES.

Fruit jellies constitute one of the most attractive and tasty forms of utilising fruit; they keep indefinitely. Apples, quinces, loquats, plums, apricots, grapes, strawberries, guavas, Cape gooseberries, rosellas, and a host of other fruit can thus be treated.

Pectic acid, sugar and heat combined with fruit juice, cause the mass to set in a jelly. For that reason fruits not quite over-ripe are preferable, as they contain a larger amount of pectic acid, which, on ripening, is gradually converted into pectin, whilst the fruit becomes soft to the touch. When combined with sugar, and boiled for a certain time and then cooled, fruit juices coagulate and set into a jelly.

The amount of sugar required is approximately equal to that of the fruit juice. In order to impart to the jelly a clearer fracture lemon juice is at times added. If the fruit is cut with a sharp spoon (not iron) or with a plated knife, it will not brown.

To make into jelly the fruit is boiled in an enamel, aluminium, or a copper vessel, peel, core, and all, until quite soft, but not pulpy, water to cover the fruit is used. It is then strained by squeezing through a cloth or through a flannel bag. To each pint of juice, add  $\frac{3}{4}$  to 1 lb. of brewer's crystals. After boiling briskly for half an hour the liquid, placed on a plate, will jelly. This takes place at a temperature of about 113° C. (235° F.). Another good test is to let a drop or two of the boiled fruit juice into a tumbler of water, when, should it sink to the bottom of the glass, it is ready for bottling. The jars should be hot when filled to the edge; all air bubbles are removed with the back of a knife drawn across the surface.

After standing for a few hours in a cool place, away from dust, the jars are covered with paper that has been dipped in milk, or white of egg, or in spirits of wine, and put away until required.

Fruit juice can be kept for jelly-making by running straight from the press into clean glass jars or bottles immersed to the neck in hot water, which is then kept above 140° F. for half an hour or so. Stoppers, corks, caps, or rubber rings should be heated in the same way, and the bottles of juice closed when hot; such sterilisation of the acid juice obviating the necessity of adding chemical preservations.

### GATHERING AND MARKETING FRUIT.

As the fruit ripens it is picked, packed, and marketed. More skill is required to effect these operations to the best advantage than is at first imagined, and in this respect past experience is of no mean value.

#### GATHERING

plays an important part in the keeping of fruit. Just when and how to pick is an art which is acquired, but certain peculiarities, when observed, will secure for the grower the reward of his labour.

The right stage at which fruit should be picked is in a measure governed by the market it is destined for. The local market is best supplied with fruit fully ripe, when it possesses in its fullest measure all its succulence and attractive colouring. For shipment to distant markets, and for long keeping, it is imperative to pick fruit when ripe, but before it reaches the period of full maturity. In such cases, quality, and appearance must give precedence to long-keeping property. There is no very well-defined line showing ripeness from full maturity, and here experience is needed; that experience, however, is easily acquired.

If the fruit is picked too green it also often shrivels, lacks flavour, and does not sell to advantage. If too ripe, it does not carry well.

Apples are picked at different stages. Most large, early soft-fleshed apples, such as Mr. Gladstone, Red Astrakan, Lord Suffield, and others of the same class, should be gathered early before they are fully ripe. They then travel much better. They should be marketed as quickly as possible after picking. It is surprising how soon early apples lose their freshness and, therefore, their marketable value after being gathered. They soon become mealy, disorganisation of their tissues set in, and they rot.

As regards mid-season apples, the state of the market should influence the period of picking.

Late apples for home use or local market should be left as long on the trees as possible. It is certainly a mistake to sell, with mid-season fruit, apples which if kept a month or so longer would sell much better.

For long-keeping apples for export, gather when the fruit is full grown, and the pips turn dark brown or nearly black. They will colour and mature during transit.

Pears require, in gathering, much the same treatment. Few pears are at their best if allowed to ripen on the tree, they either become dry or mushy at the core or develop hard stone cells or a woody kernel. Early pears should always be gathered for market before they become fully ripe, and should be marketed rather under than over ripe. Mid-season pears may remain on the tree a little longer, except the Bartlett or William's Bon Chretien, which, picked when fully grown, but hard, ripens without shrivelling. Late pears should be picked before they are fully ripe, or else they become gritty. Kieffer's pears are picked two or three weeks before they are fit to eat, if allowed to hang until ripe, the core becomes a mass of woody lumps. Apples and pears, when fit to be picked, snap clean off the fruiting spur upon being lifted gently upwards. This avoids breaking off the fruit spur to which they are attached, and upon which next year's fruit would be produced. For packing, they should not be allowed to remain on the trees until the surface has a greasy appearance and feels greasy to the touch. When allowed to reach this stage, they will not keep as well as those gathered earlier.

When picking peaches, it should be remembered that a fine appearance always infers good flavour and other merits. Peaches and apricots seldom colour well after they are picked, and picking is one of the most difficult parts of the business of peach and apricot culture. Most people can pick green pears and apricots and knock them down to the ground, but it takes some experience to judge, by a subtle feeling of the fruit when pressed between the finger and the thumb, when it is ready to come off. After a little practice the picker can generally tell by the colour of the fruit whether it is fit to pick or not. When a large number of trees have to be gone over it is advisable to pick a little too soon rather than let the crop get ahead of you, as, when ripe, the wind often brings them down by the bushel. It is sometimes two or three weeks from the time the first apricots and peaches are fit to pick until the last are ripe; the trees should be gone over two or three times a week. In some large orchards in America the pickers do not climb up the trees, this process being considered slow, and resulting in much green fruit being knocked off. In those orchards it is preferred to jar the tree when the dew is off and collect the ripe fruit, which then does not pick up dirt. For that purpose the ground underneath the trees is reduced to a fine tilth, so as to save bruising the falling fruit. The jarring is done with a long pole or bamboo with a hook fastened at the end, and the knack of delivering the blow results in just that fruit which is of the proper

stage of ripeness being brought down. A similar process is used when gathering prunes.

Plums may be picked almost green for distant shipment, as they colour in transit. This is even more noticeable in the case of the Japanese plums, which ripen and colour very well when stored in a cool, dark place.

Cherries and plums, if allowed to hang too long, are severely affected by the fruit-rot fungus. For the same reason they should always be picked when dry, or else decay will soon consume them. When picking cherries and plums the stem should be cut off with the thumb nail, and the fruit itself should not be touched, lest the delicate bloom be rubbed off.

Persimmons have not yet been shipped away to any large extent, although they lend themselves to long shipment, as they are picked when well coloured but still hard, and on keeping soften and mellow. When the consumers learn what stage that fruit should be eaten in and acquire a taste for it, a large trade will develop. With careful packing, they would travel long distances and open up at the end of the journey sound and good.

Figs are picked when fully ripe; they do not ripen after picking, and do not become sweeter than when cut from the tree. As they do not ripen all at once, the trees must be gone over daily. A ripe fig is soft to the touch and is generally wrinkled and hangs downward. Some kinds, when ripe, show seams or cracks on their jacket. For drying, they should be cut when they contain about one-third of their weight of sugar; for eating, they may be gathered when they are sweet and palatable. They should on no account be shaken off the trees, as bruised figs soon sour, and a few such would spoil a whole box full. Pulling the figs from the tree will also injure them. The proper method is to cut each ripe fruit clean off the branch and carefully place it in boxes or trays. Those figs which hang high up the tree, beyond easy reach, may be picked by means of a readily-made appliance, consisting of a light pole with a jam tin with sharp edges, nailed to its extremity. The edge of the tin is pressed against the soft fruit stalk of the fig, which it cuts, and then the fruit drops into the tin.

Grapes are best picked when fully ripe. If picked when just coloured, but tart, they won't ripen further. The bloom always shows when grapes ripen. Care should be taken, when picking the bunch, to hold it by the stem, which is then snipped with shears. Early, tender grapes, with soft skin will travel better if picked before they are fully ripe. More fleshy grapes, on the other hand, gain both as regards quality and appearance if allowed to hang until sun-kissed and quite ripe.

Gooseberries may be marketed either green or ripe. It is considered less exhausting to the bush when the smaller fruits are



picked green and the finest ones allowed to ripen. Green gooseberries are stripped from the branches quite rapidly. They may then be run through the fanning mill to free them from leaves and then packed for market.

Currants are allowed to colour, and are picked when they are ripe.

Strawberries are picked with their stalks when they have quite coloured. A strawberry which has a green or white tip seldom carries well if picked at that stage.

Blackberries and raspberries are not necessarily ripe when they have coloured. They should be soft and free from acidity, when they shake off the bushes readily and part from the stem on which they grow.

Melons sometimes puzzle the inexperienced growers. Water melons often sound hollow to percussion, and the stalk begins to wither, although this is not an infallible sign. A crackling sound is heard when pressing lightly on the melon. One of the best symptoms, however, is the clearer colour of the rind, which at times shows a faint tint of yellow. Musk and rock melons, when ripening, sometimes crack more or less up to the stem. On pulling they should come clean off. Some of the larger varieties do not part so readily from the stem, and if pulled show a large hole in the rind; with those it is best to cut the stem.

For Pineapples, well ventilated crates are necessary. The width should be sufficient to take the pineapple crossways, the crown pressing on one side and the stalk on the other; soft paper or maize chuck being used to keep the pineapples from bruising one another. A crate 3ft. 6in. x 1ft. 6in. x 1ft. 6in. will hold a dozen good size pineapples placed in two layers.

Of other fruits, bananas, plantains, and tomatoes are picked when just showing faint signs of approaching maturity, as they ripen during transit, and may with safety be held back until ready for use.

#### FRUIT PICKING APPLIANCES.

For the convenience of pickers, and for ensuring that fruit is gathered expeditiously and without bruises, a few ingenious orchard appliances are here illustrated.

A long and light orchard ladder is essential when pruning tall trees and gathering fruit. Such a ladder can readily be made of some fibrous kind of timber, such as stringy bark or oregon pine. The peaked top enables it to be run into the top of tall trees and rested against a branch.

On page 129 is illustrated a clumsy four-footed step-ladder, which is generally heavy and easily dislocated. An ordinary-hinged

step ladder with a flat top, where baskets may be placed, is very useful.

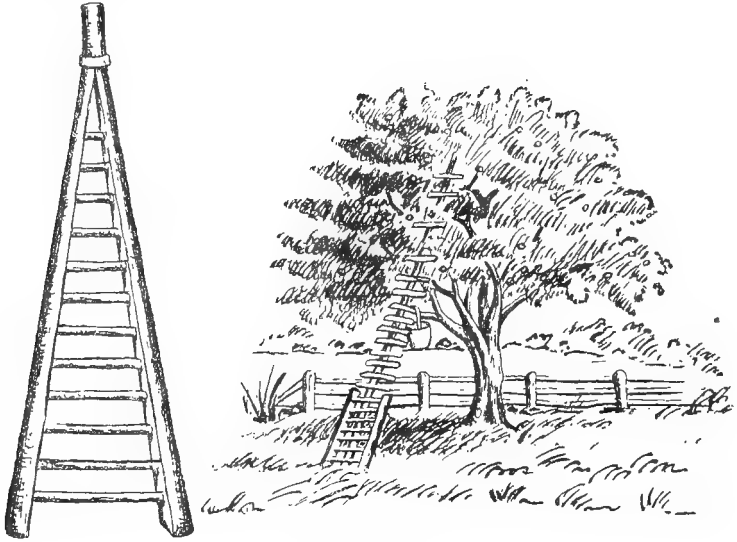

Fruit Ladders.

Some fruit often hangs at the top of long branches and out of the reach of the pickers. One common way of getting them down consists in dislodging them by means of a long pole. It generally happens that such fruit is knocked about and bruised beyond recognition. In order to reach these outlying fruits, various kinds of fruit-picking devices are used, two of which are here illustrated.

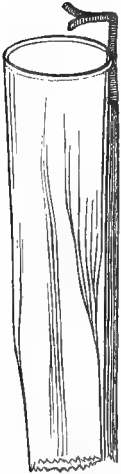

V. Picker with delivery sack.

This picker consists of a long pole armed at the end with a V-shaped hook, which pulls the fruit from the stalk; a canvas hose stretched round a hoop fastened underneath the picker conveys the fruit to the hand, one fruit only being allowed to come down the bag at a time.

The second design is another ingenious one, which any tin-smith can make. It should, for the sake of lightness, be made of tin-wire. In that case, the fruit is delivered to the picker by taking down the contrivance.



Wire Picker.

A particularly convenient one is the orchard ladder, designed by Mr. Godfrey Hester, of the Blackwood, for pruning or for picking fruit. The ladder is described as being really a wheel-

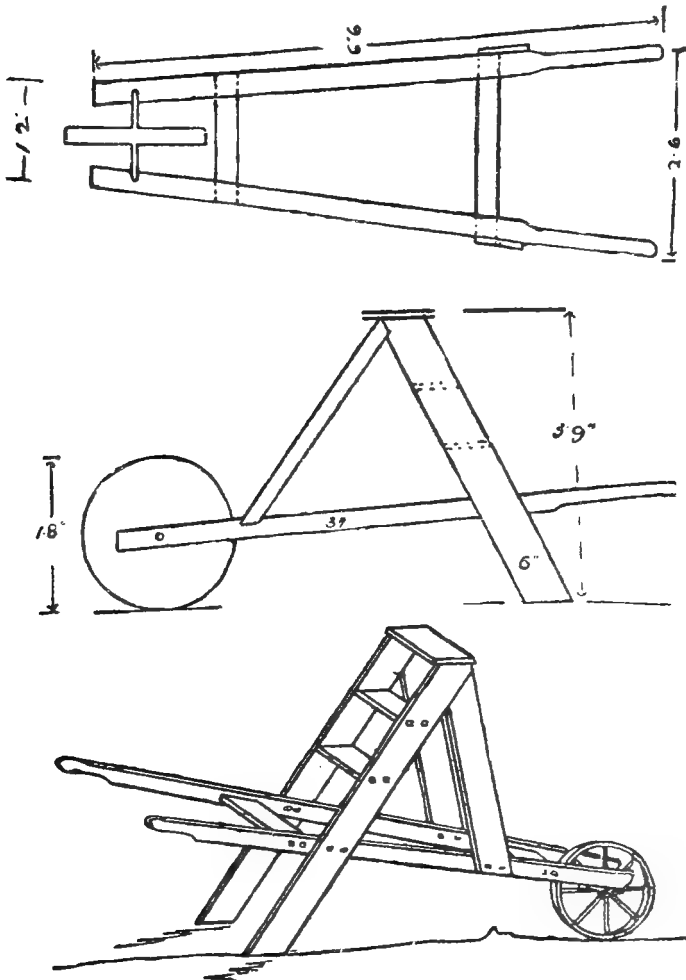

Mr. Godfrey Hester's Orchard Ladder.

barrow frame with a step-ladder attached, the step-ladder portion being brought forward on such an angle to insure absolute stability. The ladder is undoubtedly an improvement over all other appliances of this nature, inasmuch as it can be wheeled in close to the

tree and the fruit picked without damaging or destroying the tree or interfering with the crop. The same, of course, applies to pruning operations. The wheel of the ladder is 20 inches in diameter, with a 12-inch axle, thus raising the framework 10 inches off the ground at the wheel end, whilst, at the ladder end, the frame work is 14 inches off the ground, insuring steadiness when standing on the top rung. The framework of the ladder is manufactured from 3in. x 2in. jarrah, whilst the step-ladder portion is 6in. x 1in. jarrah. There are forward stays to hold the ladder in position.

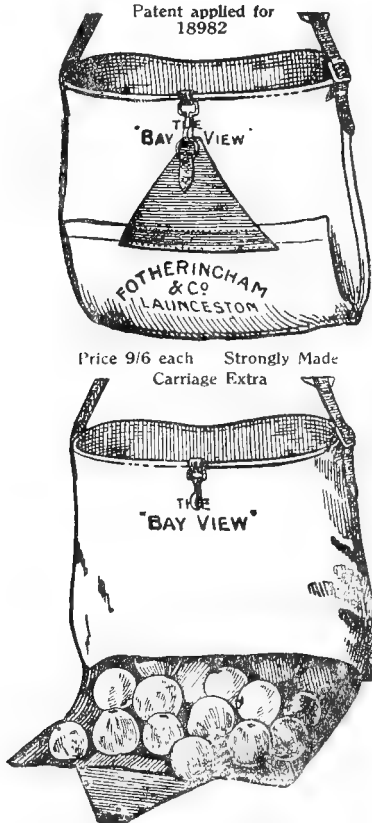

Fig. 4.  
Picking Bag.

When picking, particularly for storage and for export, the importance of avoiding the fruit being bruised or pulling the stem out need not be stressed. A doubled-up bag fastened apron-like on the belt, or better still, the kind of picking bag shown in the illus-

tration is found very convenient. The fruit can then be carefully tipped into the picking cases—kerosene cases bound with light hoop-iron last for that purpose for years.

Unless sufficiently experienced, apple pickers should be provided with rings, and no fruit, especially for the early boats, should be pulled under  $2\frac{1}{2}$  inches, unless it is not likely to fill out more.

Fruit picked before the right stage is reached often shrivel, and do not ripen; on the other hand if exported when over-ripe, blemished or diseased, nothing but loss need be anticipated.

#### GRADING.

The farther the orchard is away from market, the greater the need of bestowing on picking and packing fruits the attention it deserves. The wants of the local markets are in a manner understood and complied with by most growers; but commercial fruit-growing, which generally means shipping to long distances and necessitate numerous and at times rough handling, must be known and studied.

However carefully the fruit has been picked, it is essential, in order to secure top market price, to grade it. This is best done by hand, as most mechanical graders advertised are only suitable for sorting out potatoes or second-class hard fruit, or for grading dried fruit.

A definition of what constitutes "first-class fruit" will prove instructive to growers. A perfect specimen is not necessarily first-class fruit. First-class fruit as understood in the market is a parcel of fruit of one variety, full grown, well-coloured, without blemish due to insect or fungoid blight, carefully picked, all of as near as possible one size, shape, degree of ripeness, got up in neat and appropriate packages, showing no shrinkage, and correctly labelled. Some growers sort out their fruit into three or even four grades, such as "extras" or "selected," "fancy," and "first-class" and "culls." In that case the term second-class or No. 2 is often substituted for the term "culls."

These names are preferred by some fruit dealers to the numerical descriptions representing the quality of fruit, as although No. 2 grade may, for all purposes, be almost as good as No. 1, yet many object to appear dealing in any commodity which is not first class. On the other hand, those fancy names described above do not convey any very clear and definite idea of the standard which directs their classification, and what appears "extra" or "fancy" to one dealer may not fill another dealer's ideal.

Of fruit graders a number of types are found in the market, but they are all constructed on the same principle, and the above diagram illustrates an easily constructed home-made grader, which

finds favour in California. A strong oblong frame is constructed of 4 x 4 timber about 9ft. apart, well braced, with the uprights set wide enough to allow the shoot to play between them. The shoot (B) is about 12ft. long by 2ft. wide, and is provided with as many

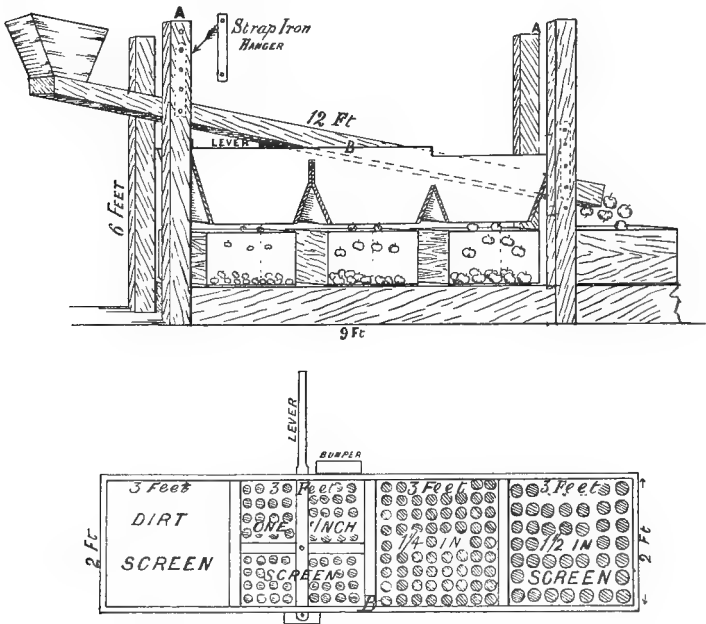

Home-made Fruit Grader

screens as it is desired to have grades of fruit. These screens may be made of galvanised iron with holes of the desired size punched into them, and may be changed to suit the kind of fruit to be graded. First comes the dirt screen, 3ft. x 2ft., then, say, the screen for small fruit and culls, which is followed by a larger screen and a larger one again, while the largest fruit may, if so desired, be delivered into a box at the end of the shoot. The lower part under the shoot contains the bins with sloping bottom so that the fruit will slide easily.

The screens shown in the lower part of the illustration are for apricots and plums; larger holes would be required for larger fruits.

The shoot is hung on the uprights with iron straps about one foot long, in which holes are punched so that the pitch of the shoot may be changed. A rocking motion can thus be imparted to the shoot by means of a lever bolted to the under side of the frame.

This lever when pulled and released strikes a bumper provided alongside, and gives to the rocking shoot a jar, which sends the fruit along. It must be remembered that no machine grades to colour or throws out rejects.

Although a preliminary grading is done in the orchard when picking, this necessary operation is completed in the packing shed, and in the case of export apples the grading and wrapping proceeds with the packing.

If the bulk of the fruit on the bench is  $2\frac{1}{2}$  inches, the packer starts on that size, and when that is exhausted, passes on to the next grade which happens to be most in evidence.

When grading, sizes range upwards not downwards; thus:—

A 2-inch apple is 2 inches up to  $2\frac{1}{4}$  inches.

A  $2\frac{1}{4}$ -inch apple is  $2\frac{1}{4}$  inches up to  $2\frac{1}{2}$  inches.

A  $2\frac{1}{2}$ -inch apple is  $2\frac{1}{2}$  inches up to  $2\frac{3}{4}$  inches.

A  $2\frac{3}{4}$ -inch apple is  $2\frac{3}{4}$  inches up to 3 inches.

A 3-inch apple is 3 inches up to  $3\frac{1}{4}$  inches.

Large sizes are not much in demand, and the fruit does not carry so well as the medium size, which are the best for export.

A good, experienced packer will grade, wrap, and pack 10 bushel cases of apples an hour and keep up the average.

Strawberries, cherries, and such like fruit are best packed straight away into the small wooden punnets, and when thus filled they may be placed without further handling into strong crates.

#### PACKING.

Good fruit deserves good packing, and bad fruit will not sell without it. Every orchardist should be well imbued of that fact, and keep it well in mind. Anything that tends to give the buyer the idea that extra care has been used in the packing will pay.

It is admitted on all hands that apart from detracting from the look of the contents, and bringing for first-class fruit second-class prices, the pernicious practice of using soiled, stained, second-hand packages often proves to be the means of unconsciously distributing destructive orchard pests.

The Commonwealth as well as the State Regulations fortunately prohibit the use of second-hand fruit cases for packing fruit.

The lower price goods packed in second-hand cases invariably fetch whenever compared with the same grade goods packed in new cases is in itself sufficient to stamp this class of package as costly to the grower, who often, moreover, is given cause to repent having used them when new blights and pests carried as spores, eggs, or larvæ in the cracks and crevices of the timber, invade his garden.

Honesty in packing is a cardinal rule which should on no occasion be departed from, and especially on a glutted market is the grower made aware of it. The glaring fraud of topping inferior fruit and rubbish with picked specimens is, as a rule, so noticeable that it passes comprehension that some should still persist in it.

It very frequently happens that in order to test the packing the dealers open the cases sideways, or on the bottom end; and even often, when a large parcel comes under the hammer, one or two cases, picked out at random, are tipped on the table exposed to view, and stand as a sample of the whole lot.

For long-distance shipping, it stands to reason that nothing but first-class fruit will pay for freight, packing, for shrinkage due to natural causes, and other incidental changes.

#### WEIGHT OF A BUSHEL OF FRUIT.

With the object of bringing uniformity as regards the contents of fruit cases, growers, and also the Legislature have adopted cases of various sizes based upon the imperial bushel standard, which measures 2,218 cubic inches.

When filled, however, the weight varies with the kind of fruit. Thus an average bushel of apples, pears, and quinces is put down at 40lbs., although a bushel of good-keeping apples weighs 42lbs; peaches, nectarines, apricots weigh 48-50lbs.; plums 56-60lbs. and more; and grapes 35-40lbs. per bushel case.

#### THE DIAGONAL PACK.

Until the numerical system of diagonal packing for apples and oranges became more generally followed, the practice was to pack in almost any kind of case, or in barrels, and it was permissible to double face the package—bottom and top—a layer of fruit being carefully set at the bottom, these for the sake of uniformity showing the same side; over these, fruit of the same grade and type was used as a superstructure, and a top layer of even and picked fruit also facing the same way was set before pressing down gently and nailing the cover.

This system has now been quite superseded by the "diagonal pack," which originated in California in connection with the packing of oranges for transport over long distances when it is essential to provide a maximum of tightness to ensure a minimum of bruising.

The advantages from a marketable point of view were so obvious and the system moreover ensured that for a given grade of fruit a definite numerical content can be relied upon that it became universally adopted in Canada and in the United States.



### Packing Apples.

Under the "diagonal numerical system," apples and oranges, according to size, are packed, not in rows directly on the top of the other but in alternated rows so that each fruit comes over the space between two or three; this gives to the whole caseful more solidity and elasticity.

According to size, the fruit is packed as follows:—

The 2-1 pack, containing 5 tiers or layers to the case.

The 2-2 pack, containing 6 tiers or layers to the case.

The 3-2 pack, containing 7 tiers or layers to the case.

The constant number of tiers or layers in the case is due to the fact that all apples in the second tier rest in the space or depression formed by the three apples underneath on which it is set; this applies right through the layer and also applies to each layer following, right up to the top of the case. Where the bigger sized apples are packed the spaces are larger than is the case with the smaller and closer fitting fruit; they sit deeper into the space below. The number of layers or tiers for each numerical diagonal pack being constant, the number of fruit in the case is readily

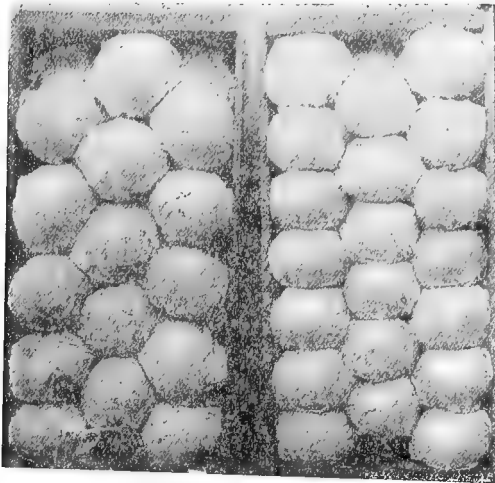

A.—2 — 1 pack.  
5 × 5.

B.—2 — 1.  
7 × 6.

known by multiplying the number in each layer or tier by the number of tiers in the case. The rows should be straight, both lengthways and diagonally.

The 2-1 pack, the 2-2 pack, and the 3-2 pack.

The fruits are so arranged that the rows run in direct lines lengthways, and also in straight lines diagonally.

The 2-1 pack is used for large size apples from 3in. upwards. The first fruit is one of the corners at the end of the case nearest the packer, the left-hand corner generally. The second fruit is placed in the opposite right-hand corner. The third fruit is set between these two fruits as shown in the fig. and the fourth fruit should be placed in line with fruit No. 1.

In Fig. A three rows of 5 apples each are shown and the pack is known as the 2-1, 5 x 5, which means that the three rows have 5 apples each or 15 to the layer or tier. The five tiers will be alike and the number of apples will be  $15 \times 5 = 75$  to the case.

Fig. B is packed with apples a little smaller and is made up of 2 rows of 7 apples each and one of 6 apples, or twenty to the tier. But as the second tier will have two rows of 6 apples and one of 7, the total for the tier will be 19. The third tier will be like the first, the fourth like the second, and the fifth or top tier will also be like the first and third.

The number of apples will be  $3 \times 20$  and  $2 \times 19$ , or 98 to the case.

The 2-2 pack is used for apples going  $2\frac{1}{2}$ in. to 3in. in diameter.

## THE 2-2 DIAGONAL PACK For Large Sizes

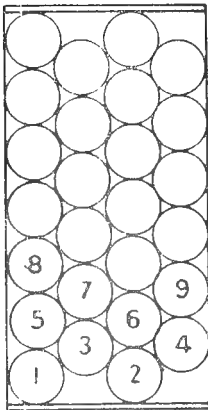

First Layer

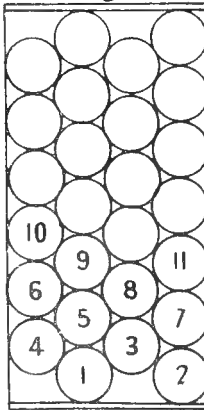

Second Layer

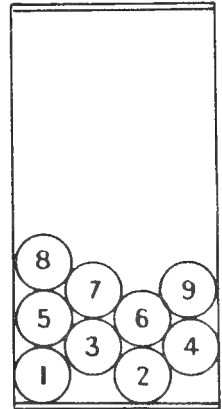

How to start  
a 2-2 Pack

The 2 - 2 Diagonal Pack. For large sizes.

The first fruit is placed in the left-hand corner nearest the packer. The second, also against the end of the box, with a space on either side as shown in the diagram. The third and fourth fruits are fitted into the spaces between the first and second and so on until the tier is all placed.

The second tier is started by placing the first apple in the right-hand corner in the space left by the first tier; the next apple in the space midway between the first and second apples, and the others in the spaces left in the first tier as shown in the fig.

The 2-2 pack carries 6 tiers, and the illustration shows fruit packed 7 x 6, *i.e.*, two rows of 7 and two of 6 apples, or 26 to the tier and 156 to the case.

The 3-2 pack is used for apples of 2in. to 2½in. in diameter. The case contains 7 tiers and each tier has five rows lengthways to the case.

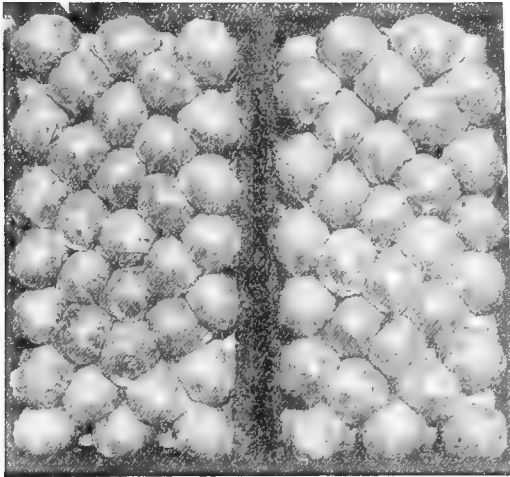

3 — 2.  
7 × 6.

3 — 2.  
6 × 6.

A fruit is placed in each corner, with a third midway between. The fourth and fifth are placed in the two spaces between the first three fruits.

The illustration shows a 3-2 pack with three rows of seven and two of six, or 33 to the first, third, fifth, and seventh tiers, and 32 apples to the second, fourth, and sixth tiers, or altogether 228 to the case. The adjoining case in the fig. shows 5 rows of 6 each, or 30 to the tier, and 210 to the case.

In all these packs, when the first tier is completed, it should be sufficiently tight to permit the box being held on end without the fruit falling out.

The illustration below shows the same kind of apple but of three different grades, cased as shown:—

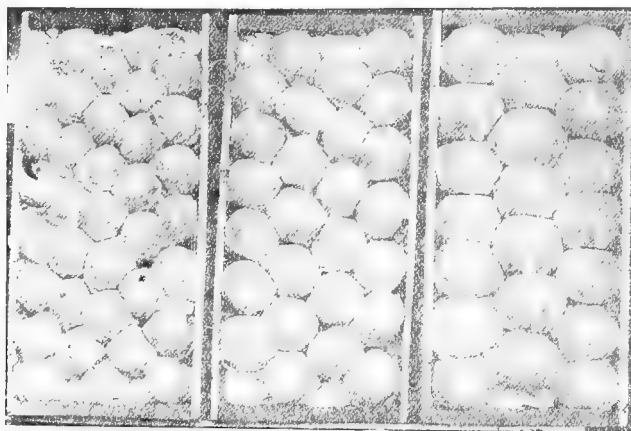

3 — 2.  
7 × 7.

2 — 2.  
7 × 6.

2 — 1.  
7 × 6

### Wrapping.

For the local or the interstate trade the fruit is simply graded, sorted, and packed, but for overseas export wrapping is the practice. The paper is glazed on one side and rough on the side next to the fruit. It is cut to the required size, varying from 8in. x 10in. and 10in. x 10in. to even 12in. x 12in.

Wrapping serves as a cushion and localises and checks the spores of fungoid diseases from spreading to the rest of the fruits in the case.

The packer, who usually wears a rubber finger-stall to more readily pick up the paper, lays it flat in the palm of the hand and with the other hand places the apple to be wrapped with the eye in the centre of the paper, closes the fingers slightly, and twists the edges, enclosing the stalk of the apple in the twist.

### Packing Oranges, Lemons, and Mandarins.

For export nothing but the best oranges should be packed. The fruit should be carefully picked from the tree and the stalk clipped above the star; fruit pulled from the tree will not keep. All citrus fruit should be allowed to sweat for four or five days to guard against the oil cells in the rind getting bruised, the rind also gets leathery, and the fruit carries better. Unless this is done there will be a notable shrinkage in the case which will open slack.

When packing naval oranges the eye should face downwards in the first tier, and upwards in the second. This class of fruit is generally packed from the open side of the case; smaller sizes, however, are often packed from the top of the case.

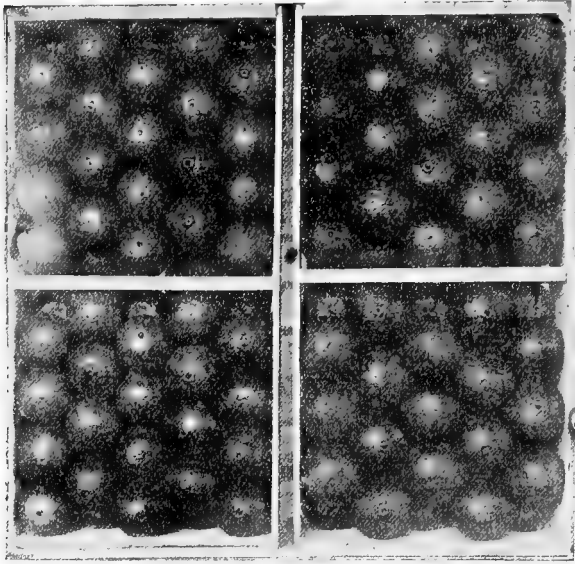

Oranges—Side pack

Lemons, after sweating, are also packed like oranges on the 3-2 or, if packed from the open side, the 4-3 principle, with rows of 3 or of 4 fruit.

Mandarins are packed in flat cases from the open side; like oranges and lemons they need to be packed tighter than apples. If they take three tiers, the first is set with eyes downwards, the third with eyes upward, and the centre on the cheek.

#### Packing Pears.

For local market pears are packed like apples in bushel cases according to the 2-1, 2-2, or 3-2 method. Good carrying sorts like Kieffer Hybrid may also be thus packed.

In packing, the eye or calyx is turned towards the packer, except when the end of the tier or layer is reached, when the calyx of the two or three pears ending the tier instead of being turned towards the packer are turned away from him and face the end of the case; this helps to tighten up the layer.

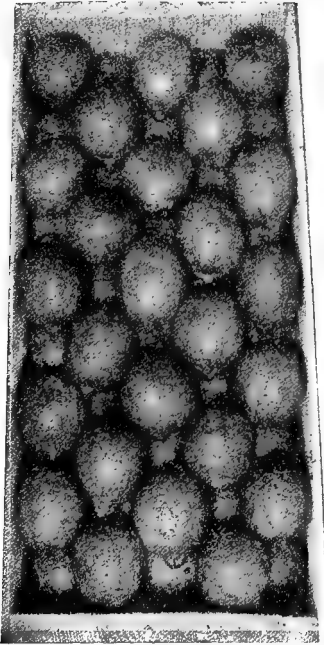

Lemons, 3 — 2 pack, 5 × 5.

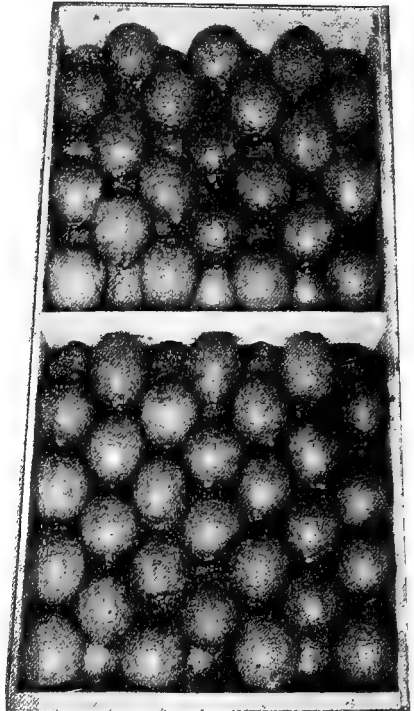

Two grades of Lemons in flat cases,  
4 — 3 pack, 3 × 3, and 4 × 4.

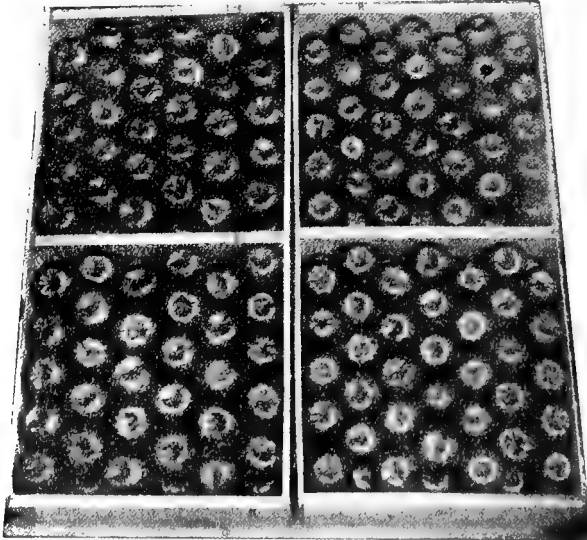

3 — 3,  
5 × 5

4 — 3  
5 × 5.

Mandarins.

In the second tier and those following, the fruit is set in the spaces left by the pears of the bottom layer, and so on until the whole case is packed.



3 — 2  
5 × 5.

2 — 2.  
4 × 4.  
Pears.

2 — 1.  
5 × 5.

Pear trays have of late superseded cases and have proved very successful in packing and shipping such delicate fruit to handle as are pears.

The inside measurement of these trays are 18in. x 14 $\frac{1}{4}$ in. x 3in. Three trays are cleated together as shown in the fig., the

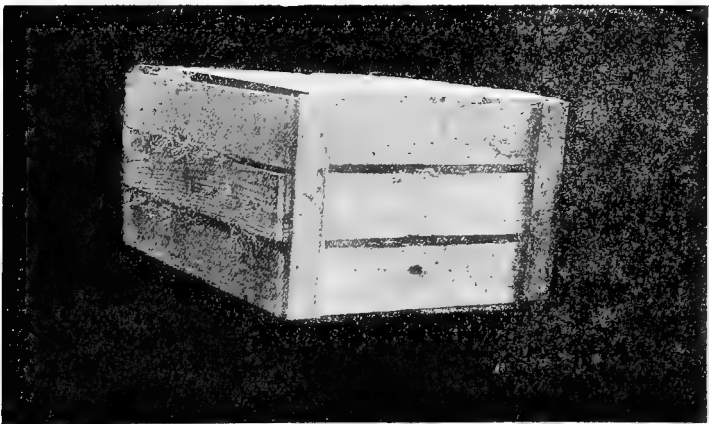

Three Pear trays cleated together.

measurement of the package being much the same as that of the dump case. The top tray, when the three are cleated together, is the only one which requires a cover, the first tray of course having its bottom or outside cover.

The illustration shows three grades of pears packed in trays. It will be noticed that all the pears face in the same direction with the exception of the top fruits, which are reversed so as to present

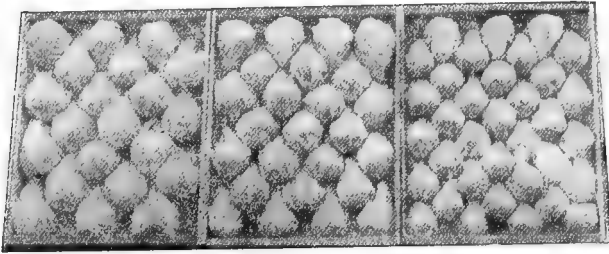

3 — 3.  
4 × 3.

4 — 3.  
4 × 3.

4 — 3.  
5 × 5.

Pears packed in trays.

the eye or calyx to the outer end of the package. It is advisable to line the bottom and the top of each tray with a thin layer of wood wool which helps to guard against the pears rubbing and chafing.

#### Nailing-down Cases.

When the cases have been properly packed there should be a slight bulge of fruit over the sides. The case is placed for nailing down over two cross battens on the floor, or on the packing table. Cross cleats, soaked in water before nailing to prevent splitting, are nailed through at each end of the cover boards. When the first cross cleat has been nailed down the lid boards are pressed down over the bulging fruit, and a second cross cleat is nailed down at the other end of the case.

Four  $2\frac{1}{2}$ in. case nails are sufficient to secure each cleat.

#### Branding.

Neat and distinct stencil plates with block letters are applied over the ends of the case and show the variety of fruit, name of variety, size of fruit or the number in the case, name and address of the grower, name of the State, and the capacity of the case, *i.e.*, "one bushel."

On the other end are stencilled the initials of the firm the fruit is consigned to, and the port of destination.





Nailing down case.



Nailed-down case over cross battens showing bulge top and bottom.

### Packing Grapes.

GRAPES do not all carry or keep well. Those late kinds with a tough skin and firm flesh and with a pedicel that breaks clean off the bunch instead of tearing off the berry, are the best for shipping.

The bunches of grapes having been snipped off the vines with as little handling as possible, are carefully laid in baskets, and taken to the packing shed. It is preferable to pick them in clear, dry weather, and in the cool of the morning. When packing in the large cases, which are first lined with clean white paper, commence by packing the bunches firmly and neatly together, stalks inside and point downwards. After packing a few layers, rock the case sharply to cause the grapes to settle firmly, and proceed in a like manner until the case is full. The last bunch or bunches should fit in extra tight, the top layer having been carefully laid on the surface, which should stand an inch or so above the side of the case. The lining paper is then folded on top, the lid laid flat, and pressure gently applied with the knee whilst the nails are being driven. Any small empty corner or hollow can with advantage be filled by means of a few berries snipped off by the scissors.

Nothing in the shape of packing should be placed on the top or among the bunches for the local market. Growers within easy carting distance of the market take their fruit in open cases lined with paper, full loads being carted by means of an extra decking made of loose boards fitting on the lorry frame or on the spring cart. Grapes thus delivered to market look fresher and command a much better price than similar grapes nailed down and carted or railed to market.

For export, cork dust is well sifted in between the berries. The cork dust should be coarse, as, if too fine, it spoils the appearance of the berries, and works out of the case.

The grapes should not be over-ripe or sunburnt, but may be exposed to the air for a little time to allow of the skin being toughened a little before packing.

After the bunches have been spread out for a few hours, each bunch is gone over, and faulty berries are removed with a pair of scissors.

Of the tough varieties, the berries of which adhere firmly to the stalk, only the more open bunches are fit to pack for distant markets.

The amount of cork dust required for packing grapes (a bushel case) varies from 4lbs. to 6lbs. Begin with 6 lbs., and with practice reduce to 4lbs.

Some of the tougher grapes, such as Almeria, Flame Tokay, Emperor, when properly packed in granulated cork, will carry without cool storage to distances of 12 to 14 days' travel from the port of shipment, and open out in excellent condition.

With good carrying varieties of grapes, suitably packed, an important trade with India, Java, and Singapore, only ten to twelve days from our shores, lies within our reach.

Export grape cases weigh 40 to 41 lbs. gross, the weight being made up of 28 to 30 lbs. of grapes, 4 lbs. cork dust, and 8 lbs. for the case. There is a shrinkage of a pound or two at the end of the voyage.

### FRUIT PACKING HOUSE.

In all commercial orchards some roomy and well-ventilated and well-lighted shed or building is required for receiving, sweating, storing, sorting, and packing the fruit. The size should depend on the quantity of fruit to be handled at one time.

The plan given below shows a fruit-packing house half as long again as it is wide. A dry well-ventilated cellar is convenient for storing cases in shooks and packing material.

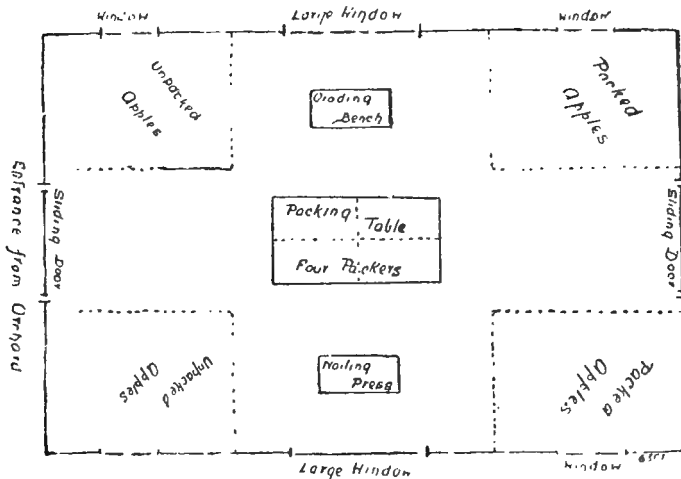

PLAN OF PACKING HOUSE.

It is found convenient to have the floor of the shed on the same level as the floor of the spring carts or lorry conveying the cases of freshly picked fruit from the orchard.

A roomy table with as many compartments as there are packers, allowing 3ft. by 4ft., holds plenty of fruit, and can be replenished as required.

The illustration of the interior of the citrus packing shed at Harvey, shows a sloping bench running along the side of the packing house. The bench has rounded laths bottom, set  $\frac{3}{4}$ in. apart to

permit leaves, twigs, etc., to fall through. Packing trollies with cases set at a convenient angle for quick packing, and a tray holding the wrapping paper and the packer's ticket or number are also shown; also the packed cases ready to nail down.

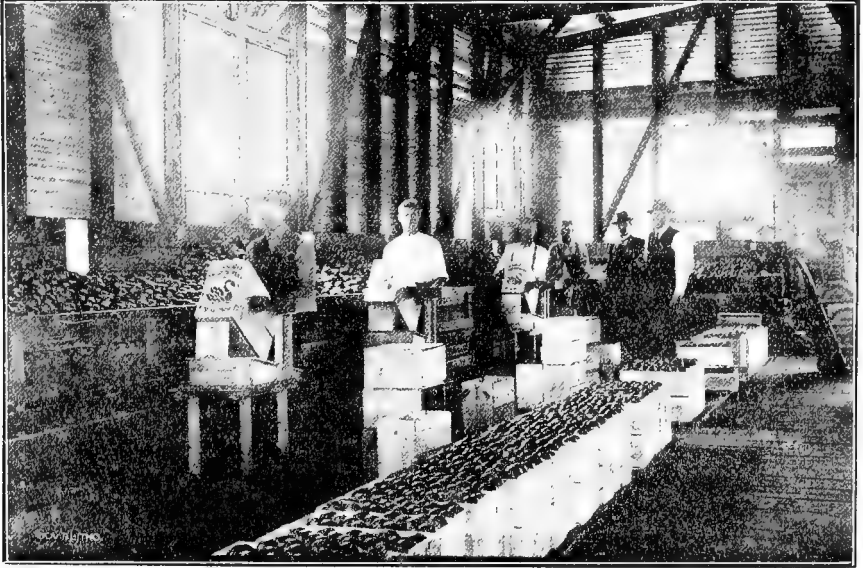

Interior Citrus Packing House, Harvey.

### CURING OF LEMONS

Oranges and lemons must undergo a preliminary process of curing before they are packed and shipped to distant markets.

Whenever possible, citrus fruits should be picked in dry weather, but this is not always practicable with us when they chiefly ripen during the rainy winter months; should they be wet, they must be dried before packing.

When *picking* for long storing, only those fruits which are free from blemishes should be chosen; any thorn prick or scaly fruit will have a very poor chance of keeping. Some pickers are even so careful that they keep their nails well trimmed. Each fruit is individually clipped off the branch by means of specially constructed lemon clippers with blunt blade tips and a spring like those on scateurs; a knife at times grazes the fruit and causes it to rot.

The fruit, when picked, is placed either in baskets or a waist sack, and carefully transferred to the sweat boxes. Before sweat-

ing the lemons are washed, if necessary, to remove scale insects, and the sooty mould or fumagine. This is done with hand brushes or in specially constructed washing machines.

In large groves a good plan is to have a child follow the picker with a padded basket to receive the fruit.

The rind of a fresh-picked orange or lemon is easily bruised, the oil cells are then turgid and distended, and the slightest bruise or scratch ruptures them.

For long keeping, lemons are picked still green when they attain the size desired, pickers using metal rings of the required diameter, *i.e.*,  $2\frac{1}{3}$ in. to  $2\frac{1}{2}$ in. The trees are gone over about once every month, this lightening up of the trees help them to carry the later fruit.

According to seasons a quantity of lemons will ripen before they attain the picking size. These "tree-ripe" fruit are picked as well as the right size green ones, but being already coloured and matured they do not require curing, and are marketed as soon as possible, as they lack keeping quality.

Only the right size, sound, green lemons are "cured" for long keeping and a better market. During the curing process the colour gradually changes from green to a waxy, lemon yellow, the thick rind becomes thin, the layer of white, spongy material it is made of shrinking materially, leaving an apparent increase in the quality of juice under a thin, leathery rind. The process takes about a month to six weeks to run.

In California, where the art of curing has been systematised, the lemons are washed if necessary and sweated; then they are loosely packed in packing cases, which are stacked and covered by curing tents. It is conceded that for successful curing there should be as much uniformity as possible of temperature (85 to 90 deg.) and humidity. The packing house and curing tents are so constructed as to bring about these conditions. These tents consist of rectangular rooms usually of sufficient size to hold about 600 packing-cases of loose fruit, or about one car load. They consist of a frame about 15ft. x 15ft. The sides and tops of these rooms are of canvas, the sides being lapped over one another at the corners and fastened with cords drawn through hooks. Both sides and ends of the tent can be raised or lowered by means of cords and small pulleys. A roller sewn at the bottom is found convenient for that purpose. In this way it is possible to allow air to circulate among the boxes or to shut it out almost entirely. Boxes are stacked inside these tents in blocks 12ft. x 12ft. x 8ft. high. On ~~peal~~ nights the curtains can be rolled up and lowered again in the morning. The fruit is gone through carefully every fortnight, each case being taken down separately and stacked up in a fresh heap.

A successful Californian lemon grower thus describes his curing room, which is based on the principle mentioned above, and offers the advantage of being simplicity itself:

The lemons are always picked carefully in the autumn; but only those that are green are stored. The coloured ones are marketed at once. The lemons to be cured are placed in boxes 16 by 10 by 24 inches, filled so that when stacked the case on top does not rest on the lemons below.

If the weather is dry, and the lemons have sweated, these cases are the next to be placed in a cellar which is dug in the ground, the size being according to the space required. One top ventilator is all that is necessary, and there should be no others to cause a draught with the exception of the door which should be open at night, when the temperature should not be over 60° F. The cellar should be kept perfectly dry. The boxes are stacked close together to avoid the circulation of what air there is. The lemons are rarely sorted over if kept according to above directions. The rind is not thicker than one-eighth of an inch all through, smooth as a glove, and the lemons are as firm as the day they were picked off the tree.

The essential conditions of such a house are exclusion of light, regulation of temperature, ventilation under control, convenience of handling. Provided these requirements are borne in mind, much less pretentious storing houses, readily constructed out of material on the ground, may be made to answer the same purpose. Any roomy shed, built with pug or pisé walls, about one foot thick, with ventilators at the top of the walls, will prove cheap and convenient. The ceiling can be made of split logs with a layer of pug on top, whilst an iron roof, with projections to save the walls, would efficaciously keep out the weather. In order to keep such a house cool, the doors could either be left open at night and closed during the day, or a tunnel might be dug a couple of feet or so under the ground, leading into the storehouse. Such a tunnel, with a cowl or windsail on the outside end, would create a cool draught which could be regulated at will inside the structure.

The sweat boxes are kept off the floors so as to insure the circulation of air around them. They are also better placed in tiers over the shelves with ample room above for the occasional examination of the fruit.

For home use when sound, green lemons of the right size may be kept on a dry floor imbedded in dry sand, which is sifted over them.

#### WHAT A FRUIT CASE SHOULD BE.

As packing-cases are at times scarce and difficult to procure in the height of the fruit season, thoughtful growers should lay in a stock some time beforehand.

Damp and light give a weather-stained look to the wood and turn it yellow, and the shooks should for that reason be stacked in a dark and dry place. The dryness of the wood is of great importance, much loss being caused by the use of green timber for cases that are used for export.

The cases should be made of light but tough wood, which does not split when the slats are nailed together. Our hardwood cases are easier to nail when half dry, jarrah particularly splitting unless blunt case nails are used. The material should be sufficiently strong to withstand a moderate amount of pressure, such as that caused by heaping up cases on the top of one another or by slinging them into and out of the ship's hold.

The cases should be lined with strong white paper, and after packing they should be left, if possible, for a day or two if the fruit is of a keeping class; they will thus settle before the lid is nailed down.

The temptation of fastening the lids with twice as many nails as are really necessary should be resisted, as forcing the lids when much nailed down frequently spoils them, and also some of the contents of the box.

Large readable labels showing the contents of the case may not always save the packages from rough handling, but will do so occasionally.

Much confusion exists as regards the size and shape of fruit cases in the various fruit-growing countries, and perhaps more so in Australia. Although our cases and their subdivisions, approximate as nearly as possible a bushel and fractions of that measure of capacity, their contents vary somewhat from the Imperial bushel, which measures 2,218 cubic inches.

*Cases approved by the Australasian Fruitgrowers' Conference, October, 1911.*

Variety of Case.	Inside Measurements.	Cubic Capacity.	Recommended for Fruits of—
		Inches.	
1. Australian Dump Bushel Case	18 x 14½ x 8½	2,223	Apples (interstate and export)
2. Australian Half Bushel Grape Case	18 x 11½ x 5½	1,110	Grapes, etc.
3. Australian Dump Half-Bushel Case	18 x 8½ x 7½	1,111½	Apples, etc.
4. Australian Flat Bushel Case (without division)	26 x 6 x 14½	2,223	Citrus and other fruits (interstate).
5. Australian Flat Half-Bushel Case (without division)	26 x 6 x 7½	1,111½	Citrus and other fruits.
6. Australian Quarter Bushel Case	13½ x 10½ x 4	556½	Cherries, Gooseberries, etc.
7. Australian Orange Export Case	24½ x 12 x 12	3,564	Bananas, Pineapples, and with ¼ in. division for Orange export.

### THE OVERSEA FRUIT TRADE.

Western Australia, because of its particularly suitable climate, its favourable geographical position, and the extension fruit culture has attained, shares with gratifying success an important part of the Australian fruit trade with the European and the nearer Asiatic markets.

Under the stimulus given by the settlement of returned soldiers on the land, a fresh spurt has been given to further planting, and the importance of the oversea fruit trade is one that offers unmistakable and gratifying signs of expansion.

Both Albany, Bunbury, and Fremantle, the last ports of call of fruit-trading steamers, and of the mail boats, are a week nearer the large European markets than is Melbourne, and eight or nine days nearer than either New South Wales or Tasmania.

Apart from the notable advantage of quicker delivery, a better position in the hold of the steamer, always militates in favour of the last shipped fruit.

But the fact that our fruits are offered for sale on oversea markets in the early European spring and summer ensures for them a ready sale due to absence of competitors.

These new markets, which have only been opened comparatively recently, have been made available by the improvements and expansion of cold storage during transit as well as before and after shipment.

### COLD STORAGE FOR FRUIT

constitutes at the present time one of the safest and cheapest methods of dealing with fruit at times of glut of the market. It is often, with fruit and other perishable products, either a feast or a famine, but with more precise knowledge regarding methods of picking and packing, and also of cold storage, which private as well as public commercial enterprise has placed within the reach of all, it is now practicable to withhold fruit from the market when it is most abundant and when prices are low, and offer it for sale with profit when it becomes scarce.

The profits, however, are not so large as they would appear to some, and there are risks to face and costs to incur in holding a crop over. The fruit, for instance, must possess keeping qualities; some are of such a kind that nothing will prevent speedy deterioration. Most summer apples, it is well known, will soon, however carefully handled, go mealy and rot; most grapes are bad keepers; strawberries will, under no circumstances, keep more than a couple of days or so. Moreover the fruit may, on account of bad culti-



vation, rough handling, or attacks by insect pests and blights, fail to keep well although the variety itself is known to possess good keeping qualities. To risks and losses due to the causes just enumerated must be added cost of handling, re-sorting, and re-packing, also, rent of cold storage room, which all tend to greatly reduce the profits to the grower or the dealer.

The conditions required for preserving fruit in cold storage are pure, dry, cold air, and the following table, issued by the Kansas Experimental Station, shows the temperatures which, for certain products, give the best results:—

Product.	Temp. F.	Package.	Keeping period.
Apples, winter .. ..	32-35 ..	boxes ..	5 to 8 months
Pears .. ..	33-38 ..	„ ..	2 to 4 „
Quinces .. ..	33-35 ..	„ ..	3 to 4 „
Peaches or Plums .. ..	36-40 ..	crates ..	2 to 4 „
Grapes .. ..	38-40 ..	boxes ..	2 to 8 „
Berries, Cherries .. ..	40 ..	punnets ..	1 to 3 „
Lemons and Oranges .. ..	40 ..	boxes ..	8 to 12 „
Water Melons .. ..	40 ..	„ ..	3 to 6 „
Musk Melons .. ..	40 ..	„ ..	2 to 3 „
Tomatoes .. ..	38-40 ..	crates ..	2 to 4 „
Cucumbers .. ..	38-40 ..	„ ..	1 to 3 „
Celery .. ..	35		
Onions .. ..	34-40		
Potatoes .. ..	36-40		
Asparagus or Cabbage .. ..	34-35		

For juicy summer fruit the value of cold storage is not so much for keeping them for any length of time as for tiding them over a glutted market. Such fruit as strawberries and raspberries should not be kept over a day or two. Grapes on the whole do not retain their flavour, bloom, or appearance if kept longer than a week or two; a few stand cold storage well. Of pears, some will keep well; others, such as the Bartlett, may be put in early in the autumn, and stowed away in such a manner as will allow the cold air to circulate freely around them, and should be sold as soon as the market is relieved. There is then a good demand for them. Late peaches, firm and sweet, may be stored with profit. Apples, of all fruit, keep best, and moreover, improve by keeping in cold storage, but with whatever fruit is stored, success will depend on the kind, condition when gathered, care in handling, packing, method of storing, as well as the temperature at which it is kept.

Two other conditions influence the keeping quality of fruit to a larger extent than most people imagine. One is the quality and amount of fertilising nutriment the tree draws from the earth during the period of its growth, and the other its freedom from attacks of parasites, the sort of blight affecting it, and its state of health generally.

### HOW TO COOL AND THAW FRUIT.

Fruit for export in cool chambers must not be placed hot and fresh from the fields into the cool chamber. Thorough "sweating" must precede, then sorting, wrapping in oiled paper, and placing in non-ventilated, insulated chambers, the temperature of which is slowly lowered to 32° to 40° F. (zero to 4° C.). This temperature must be uniformly maintained during the whole period of storage. Neglect of this condition caused, in the initial days of fruit transportation to distant markets, considerable damage and loss.

On arrival at its destination it is essential to the good keeping of that fruit that almost as much thought and time be given to its return to a normal temperature as was done when cooling it. This warming up should be slow, gradual, and carried out in a dry atmosphere in a room of about 40° F. To lack of proper attention to these details is chargeable a good many of the failures in fruit shipment.

### SHIPMENT CHARGES.

Until a few years ago shipping fruit from the Australian States to the London market had not proved a uniformly remunerative enterprise. Apart from the heavy packing, shipping, and handling charges which are known beforehand, heavy losses have been sustained through circumstances which may be only guessed, but which nevertheless remained without reasonable explanation.

Out of shipments of 100 cases of carefully selected, graded, and packed fruit, for instance, half the consignment or more would sell at a remunerative price, whilst the remainder would on opening show signs of decay, and would be sold at a loss. It is fortunate, however, that competition in the fruit-carrying trade caused the shipping companies to pay closer attention to details which safeguard the interests of their customers, and every season since has shown less waste in the fruit cargoes shipped to the European markets.

Prior to the war, the cost of shipping a case of apples from the orchard to London was:—

	s.	d.
Cost of case at orchard .. ..	0	11½
Wrapping paper and woodwool .. ..	0	2½
Sorting, packing, and branding .. ..	0	5
Railway carriage (32 miles) .. ..	0	3
Port charges and wharfage .. ..	0	3
Freight and lighterage .. ..	3	8
Insurance .. ..	0	1
London charges .. ..	1	0
	<hr/>	<hr/>
	6	10
	<hr/>	<hr/>

Fruit selling at 10s. a case of 40lbs. or 3d. per lb. would thus only leave to the grower 3s. 2d. net, which hardly paid the cost of growing. The average selling price, however, was 13s. to 15s., which proved a paying proposition, even when allowance was made for culls and rejects, which found a market locally at a lower price.

Since the war, freight has advanced from 72s. 6d. per ton of 23 cases, or 3s. 2d. per case to 8s., while the cost of labour and of all requisites have so increased that all charges are fully double the pre-war cost, and it is more than ever a matter of first importance to only ship the best grades of fruit at the proper season.

Bartlett pears should be sent at the end of January, and later varieties to follow. Apples, beginning with Jonathan, from the beginning to the middle of February. The early shipments pay well, even though the colour of the fruit may not be so good as the March shipments. Shipments after the end of April often bring lower prices, and it is not advisable to ship later, as the English and French fruits are then on the market.

Oranges, notably Washington navels, if landed in England between August and the end of the year find a market ready to absorb large consignments, because during that period shipments from other countries, such as the East Indies, Florida, and California are not forthcoming.

West Australian export grapes landed at European ports in April to June also find an empty market, and realise remunerative prices.

#### COST OF FRUIT PRODUCTION

is governed by the capital cost of bringing the orchard or vineyard to productiveness, and must necessarily fluctuate with such factors as the quality of the land, the treatment it receives, the season experienced, and the suitability of the kind of fruit grown.

To arrive at the cost of a single case of fruit, a plan, adopted by Mr. G. Wickens of the Agricultural Department, is to first ascertain the cost of working an area of fruit land which can be managed by one man, and then divide the total cost by the number of cases obtained.

Taking a 10-acre block as a convenient unit for basing calculations, and provided the kinds are such as ripen in succession, one experienced man with necessary horses and implements is capable of supplying the labour required.

The cost of good land, cleared, fenced, ploughed and subsoiled, planted with fruit trees or vines, manured and cultivated for three or four years, until the bearing stage is reached, would not be far short of £60 per acre or £600 for a 10-acre block.

House, water supply, stable and sheds, horse, implements, cart and harness would absorb another £60 per acre or a total average of £1,200 for the 10 acres.

Interest on this amount at 7 per cent. would amount to £84; wages at 10s. a day, £171; fertilisers, £3 per acre, £30; cases, say, 2,000 at 9s. per dozen, say, £52; cartage, railway freight, commission, horse feed, shoeing, spraying, depreciation, insurance, etc., £200, or say, for the 10 acres £537 as working cost, or £53 15s. per acre.

Supposing the trees are planted 25 feet apart or 70 to the acre, at the average of one case per tree, the fruit would have to sell for something like 15s. 7d. to pay working cost and interest; if two cases per tree 7s. 9d. per case, and if three cases, at 5s. 6d. per case.

Experienced orchardists consider that: provided the land is in good heart, deep, well cultivated, and clean, an average of a large-sized orchard would be 3 bushel cases of 45lbs. for a mixed lot of varieties 8 to 20 years old, and under particularly favourable conditions, 4 bushel cases or a 6-ton crop.

From the 5th to the 6th year, 1 case per tree may reasonably be expected.

## WINE MAKING.

Vintage commences with us late in January in the earlier districts, and continues until the end of April or the beginning of May in localities in the cooler Southern districts, or at a higher altitude on the Darling Ranges.

Before describing the process whereby the sweet juice of the grape is transformed into wine, a few words about the vessels, machinery, and appliances used in wine making will not be out of place.

### A FERMENTING SHED

is, in the first instance, provided for the manufacture of wine. Such a structure need not be a costly one, but it is desirable that it be roomy, high, and well aerated. Plenty of room must be provided for the crushing machine, presses, fermenting vats, pumps, sieves, tubs, and other necessary appliances.

During the process of fermentation there is a rise of temperature which may be prejudicial to the successful fermentation of the wine, and to the alcoholic strength of the newly made wine. For that reason a shed which can be well aerated, and which at night can be left open to the cool breezes so as to counteract the rise of temperature, is preferable to the old-fashioned, costly fermenting houses made of thick walls, with little ventilation.

A capacious galvanised iron shed about 32 to 36 feet wide and, according to the amount of grapes to be handled, from 60

to 80 feet long, with sides 10 feet high to the wall-plates, and a gable raised another few feet in the centre, will answer the purpose on a vineyard of 60 to 70 acres.

In this all the machinery and fermenting vessels can be comfortably lodged.

One more condition must not be overlooked: the fermenting shed must be one apart from the maturing cellars, lest the germs of fermentation which, during wine making, float about in abundance in the air get access to and disturb the wine of previous years.

As a good deal of water is used about the fermenting shed, both before and during wine making, the surroundings should be so drained that there is no accumulation of dirty liquids, which would foul the air. The building should not be damp, as moulds are not only injurious to casks and other wooden vessels, but also cause the wine to become tainted during future keeping.

A *concrete floor* with a slight fall and drains to permit flushing with water is desirable, and in order to carry the traffic it should be laid with some care. Such a floor consists of three essential parts:—

- (1.) A porous foundation, for drainage and because of the swelling and contraction of the earth.
- (2) The body, which furnishes strength and supports the third part.
- (3) The surface, which receives the wear.

The first is cinders free from ashes, or coarse sand free from clay, loam, and vegetable fibre; the second, cement concrete; the third a mixture of cement and sand—the water used should be fresh. The proportion of sand, cement, and stone vary as 1—2—4 or 1—3—5. It should be at least 3 inches thick, *i.e.*, 2½ inches in the body and half-inch surface, which is composed of mortar alone, not so wet as in the concrete. No more concrete or mortar should be mixed than can be used at once.

To prevent cracking it is advisable to make the floor up in separate slabs. Deposit the foundation and wet and ram to a solid bed. On the foundation set guides of boards set on edge and of the desired depth, and lay the concrete. The next day remove the guides between the slabs and fill in the spaces, first placing strips of tarred paper or felt against the edges of the slabs already completed. Leave the top rough to receive the surface, which is finished with a trowel if a smooth finish is wanted or with the float if it is desired to have a surface that is less slippery.

The floor should be protected from the direct rays of the sun to reduce evaporation, and sprinkled and kept moist for a few days, when it may be put into service.

## CASKS AND VATS.

Two classes of materials are more commonly used in the construction of these vessels, viz., wood, and bricks and cement.

*Timber for Wine Casks and Vats.*

The wood best suited for coopering work is the oak, which, in that capacity, stands without rival. Of oaks, some are more suitable than others. The best is a sub-variety of *Quercus robur* or European oak, viz., *Quercus pedunculata* or Slavonian oak, from the forests of Croatia, Hungary, and Russia, where it grows on the alluvial flats flooded by the Danube. The soil of these flats is exceptionally suitable for the growth of the oak tree, which, for the purposes of shipbuilding, cabinet and joiners' work, and for coopering, must embody special features. This oak supplies these requirements, which are: equal proportions and dimensions and qualities; show the compactness, uniformity, and elasticity of the fibres; and the absence of knots and borer holes. Apart from these physical properties, it also contains a fair proportion of tannin and a special sugar called "quercite," which has on the wine a very beneficial effect, causing it to clear readily, and imparting to it a peculiar but faint fragrance, without at the same time adding to it an excess of extracted matter, which is to be found in chestnut and other timber.

Amongst other kinds of oaks used by coopers are also the Burgundy oak, the Dantzic or Memel oak, and the American oak. The latter, which is useful for providing those wider boards through which manholes are cut out in the larger sized casks, is less compact than the Slavonian or Dalmatian oak, and it also at first imparts a somewhat bitterish taste to the wine.

Besides the oak, other timber, such as the chestnut, the acacia, and the redwood of California (*Sequoia*), supply wood suitable for staves.

Amongst Australian woods, the mountain ash (*Eucalyptus sieberiana*) of Gippsland and New South Wales, from the mountains of South-Eastern Australia, supplies an excellent wood for fermenting vats or for large casks. It splits freely and smoothly, and is easy to work. For small casks, with thin staves, this timber does not do so well, being rather soft and porous.

For vats, either for fermenting or when headed up, for storing wine, the two leading West Australian timbers, karri (*E. diversicolor*) and jarrah (*E. marginata*), are much used in South Australia as well as in Western Australia. Of the two, karri is more elastic. Their worst features are their tendency to warp, and their heavy density. It is said that if felled towards the end of summer jarrah will be less given to warp. The first grows in the fertile

and humid valleys in the neighbourhood of Cape Leeuwin, the second on the ironstone ranges of the coastal region of the State. The sheoak, or *Casuarina*, of our sandy soils is also used with satisfactory results for kegs and the smaller casks.

Amongst other timbers which have been used in Australia for coopering work are: The silver wattle of South-East Australia and Tasmania (*Acacia dealbata*), well spoken of by Mr. J. D. Lankester, of Ettamogah, Albury. The silky oak (*Grevillea robusta*), which gives an elastic and durable wood, valued particularly for staves of casks. Mr. Th. Hardy, of South Australia, reports having placed shavings of this wood in light wines for several months without affecting their taste or colour in any way.

The white beech (*Gmelina Leickhardtii*) of East Australia, which supplies a wood of shining paleness, not liable to rend. Mr. John Wyndham, of Dalwood, Hunter River, spoke well of this wood, which shrinks but little. Mr. E. Wyndham, of Buckalla, Inverell, considers it suitable for large storing casks, but its softness unfits it for the smaller casks in which wine is sent to market.

The blackwood (*Acacia Melanoxydon*) of South-East Australia is also used for casks, but requires previous seasoning and long soaking. The wood bends readily under steam, and does not warp and twist.

The Tasmanian myrtle: a close-grained timber, making a good surface. This timber has been used for shipping wine by some of the Rutherglen vinegrowers, who say that it does not impart any foreign flavour to the wine.

The kauri pine (*Dammara Australis*) of the North Island of New Zealand supplies an excellent straight-grained timber, excellent for vats, and sometimes used for heads of strong casks, but requires thorough seasoning to extract the resinous extracts, which give a mawkish taste to the wine stored in them.

#### Size of Casks.

The size of casks used for shipping wine differs according to the different producing countries, thus:—

	Extreme size.	Contents.
Port wine pipe ... ..	58in. x 34in. ...	113 gallons
„ hogshead ... ..	37in. x 30in. ...	56½ gallons
Sherry butt ... ..	50in. x 35in. ...	108 gallons
„ hogshead ... ..	38in. x 28in. ...	54½ gallons
Marsala pipe ... ..	65in. x 32in. ...	91 gallons
„ hogshead ... ..	41in. x 25in. ...	45½ gallons
Brandy pipe ... ..	52in. x 34in. ...	104 gallons
„ hogshead ... ..	40in. x 28in. ...	57½ gallons
Rum puncheon ... ..	42in. x 36in. ...	91 gallons
Claret hogshead ... ..	36in. x 34in. ...	50 gallons

The larger storage casks somewhat vary in shape and size, but for the guidance of those about to enlarge their cellars or build new ones, I give here the extreme sizes of some useful casks made from Memel oak:—

Capacity.	Thickness of Wood.	Dimensions.
300 gallons ...	1½ in. x 1½ in. head. staves.	... 5ft. 10in. x 4ft. 9in. at bilge.
500 gallons ...	1½ in. x 1½ in.	... 5ft. 10in. x 5ft. 6in.
750 gallons ...	2in. x 2in.	... 5ft. 10in. x 6ft.
1,000 gallons ...	2½ in. x 2in.	... 5ft. 10in. x 7ft. 2in.
2,000 gallons ...	3in. x 2½ in.	... 8ft. x 8ft. 5in.

Besides these casks, known as “round” casks, it is often found expedient to store wine in “oval” casks, to economise storage room. The dimensions of these vessels are as follow:—

750 gallons ...	2in. x 2in.	... 5ft. 10in. x 5ft. 6in. x 6ft. 9in.
1,000 gallons ...	2½ in. x 2in.	... 5ft. 10in. x 5ft. 9in. x 8ft. 6in.

Theoretically, the square cask, viz., the cask with the diameter at the bulge equivalent to the length of the cask, is the strongest as if too high, as is the case in oval casks, the greater pressure sometimes causes wine to leak at the cross groove.

### Gauging Casks

is the process of mensuration for finding the quantity of liquid any vessel is capable of holding, and also for finding its actual contents when partly full.

Several methods are used. One which gives results practically correct is by means of the diagonal gauge rod. It offers the advantage of doing away with calculations. These measuring rods are square rules four feet to five feet long. They are divided into imperial gallons and fractions.

It is diagonally inserted through the bunghole into the cask as shown in AB, and a reading of the number of gallons is taken, just under the bung stave. Next take a reading in the opposite direction, to check the first reading. Should the two tally the contents are known at once, but should there be a difference between the two readings, an average is struck. A proper gallon-measuring gauge is not always handy, and in that case an ordinary rod, showing linear inches, may be substituted for

Gauging a Cask.

it. The cask being carefully measured as above from the lower surface of the bunghole stave to the lower junction of head and



bilge stave. The rule in that case is: cube the length shown, and multiply by .00226 for gallons.

Example: a cask measured as above shows 25 inches; find the contents in gallons:—

$$25^3 \times .00226 = 15625 \times .00226 = 35.4 \text{ gallons.}$$

When the volume of small casks of wine is required, it is often found easier to find its contents by weighing than by measuring. A gallon of wine is known to weigh 10lbs., so that the gross weight of the cask from which the weight of the empty cask is deducted will give, when divided by 10, the number of gallons of wine. Thus, say, the cask weighs, when full, 585lbs., and empty, 70lbs., the difference divided by 10 gives  $51\frac{1}{2}$  gallons.

#### TO SEASON CASKS.

A “woody” taste very often taints what would otherwise have been a good wine. It is too often surmised that because a cask has just left the hands of the cooper, and is made of new wood, it is fit to receive wine straight away; as a matter of fact, the staves are still full of sappy and resinous matters, easily extracted by the alcohol in the wine, which will, unless removed, impart to the first wine with which they come in contact an unpleasant and woody taste.

Several methods are used for seasoning the timber:—

- (1) Fill the cask or the vat, as the case may be, with water—hot preferably—in which is dissolved 10lbs. of common salt for every 100 gallons capacity, and let it stand for a day or two; then run the water out and rinse the cask well with fresh water.
- (2) Another method, which is even better, consists in filling the vessel with water—either cold or tepid—and adding a handful of washing soda or of potash for every 50 gallons capacity. Let stand for several days; run out the liquid, which will have extracted a brown colour from the wood. Fill with clean water, let stand for a day or so, then run it out. If the water is quite colourless, let the cask drain. For every 100 gallons capacity, make hot one gallon of a sound wine, pour into it and bung lightly, and roll the cask about for a day or so to give time to the spirit to penetrate the pores of the new wood; then drain out all the wine and fill with sulphurous fumes, drive the bung or the plug in, and the cask is then ready for use. Rectified spirit can be used instead of hot wine, but care must be taken that no burning sulphur match is used for sulphuring, as the sudden expansion of the alcoholic vapour would cause an explosion.

If the vessel is too large to conveniently fill with water, use a more concentrated solution, and wash the sides every now and again by using a broom; this will extract much colour and resinous matter from the wood.

To season new oak casks for export, pour into them a bucket of hot water, with a handful of washing soda, and turn about for four days; then run this out and wash twice with fresh water; then pour some good sound lees into them and sulphur heavily, and after two days wash again and sulphur, and the cask is ready to receive the most delicate wine.

#### CLEAN CASKS.

It may be said that wine making commences at the moment the ripe grapes reach the cellar and the berries are crushed and separated from their stalks. Preparatory to vintage, and before the first bunch of grapes is picked, the wine grower should have all his casks thoroughly overhauled, examined, scraped, rinsed out, brushed, and sulphured.

Of the several diseases that affect wine, mouldiness and acetification can, in almost every instance, be traced back to dirty and tainted casks, and acetification, lactic fermentation, or the mannitic disease, ropiness, etc., to defective fermentation. In every case of disease of wine, it may be said prevention is easy, and cure very often beyond practicable reach.

For that reason it is absolutely necessary to secure the utmost cleanliness of all vessels—grape-mill, press, hose and pumps—used for handling the juice of the grape at the various stages of wine making.

Casks and tubs may be deeply tainted with the most troublesome germs of maladies of wine and at the same time appear clean on the surface.

A mere scrubbing with a hard brush and water will often clean a cask superficially, but the meshwork of mycelial threads of moulds, which are in reality its growing roots, and which have penetrated more or less deeply into the pores of the wood, have not by that simple method of scrubbing been destroyed, and a few days after such a superficial cleaning the mould will creep out of the wood as bad as ever before.

When breaking some old cask down, we often notice on the inside of the staves some hollow blisters caused during the process of bending the staves; behind these lurk the germs of lactic or acetic fermentation as well as that of other diseases destructive to wine, and the best way of getting at them is by steaming. That part of the cask immediately around the bunghole should receive

more particular attention, as it is often overlooked. It is from this spot that the acetic germs generally start invading the cask.

New casks, unless seasoned and treated, impart a woody and disagreeable taste to the wine. To free them from this defect they are first steamed and rinsed, then treated with a weak solution of sulphuric acid, the cask being allowed to stand alternately on one head, and a few hours after on the other; next a solution of washing soda is similarly allowed to stand in the cask for a day or two, allowed to run out. After rinsing and draining the cask is sulphured by burning a short length of sulphur tape, and it is bunged down until used.

Another method consists in filling the cask with 1 per cent. of carbonate of soda (washing soda) for 8 or 10 days; or, again, filling with a 5 per cent. common salt, or sea water if handy. For small casks 1lb. of common salt in  $2\frac{1}{2}$  gallons of boiling water; roll about, let stand, and rinse.

#### TO DISCOLOUR CASKS.

Although it is not advisable to use casks which have contained red wine for white wine, one is sometimes compelled to use them. Large red wine casks which cannot be filled with water are not easily discoloured. Even frequent washings are not sufficient to dissolve the crust which covers the staves. Such casks should be thoroughly scraped inside. If possible, they should be filled with water, to which is added two or three quarts of sulphuric acid per 1,000 gallons, and left in soda for a few days. Whenever practicable it is advisable to turn steam into the cask and then wash thoroughly. It is advisable, when acidulated water is used, to grease the taps and other metallic parts which might be corroded by the acid. The wood may remain pink, but the colour won't affect the white wine.

#### TO DISINFECT CASKS.

1st.—*Steam* is the best mould and germ destroyer that can be used. It penetrates deep into the pores and cracks of the wood, effectively destroying all living organisms; it also leads to the detection of any flaw or crack in defective vessels, and soon causes the shrunken staves to swell and any leakage to stop in what may be otherwise sound casks. When leaky casks are filled with water it should not be allowed to stand long, as it soon turns putrid and becomes invaded by moulds. It is advisable in such cases to add to the water quarter of a lb. of bisulphite of lime or loz. of chloride of lime per hogshead.

2nd. *Chlorine Gas*.—For casks, for every 100 gallons capacity pour into the vessel 162 grammes (2ozs.) of chloride of sodium

(common salt) or of chloride of lime, dissolved in a gallon of boiling water; to this add a small quantity of sulphuric acid, drive in the bung, and let the chemical reaction set in inside the cask. Under the influence of the sulphuric acid, chlorine fumes are disengaged



Steaming Cask.

from the chloride and effect a complete disinfection. This chlorine gas, however, should be got rid of before putting any wine into the cask on account of its strong irritating action on the tissues of the digestive organs, and also of its pronounced bleaching action, which would decolourise the wine. The method, although very efficacious, needs to be applied with a certain amount of care.

The addition to the common salt of one ounce or so of powdered black oxide of manganese causes a more ready evolution of the chlorine gas at a lower temperature, and is for that reason an advantage. The chlorine gas combines with the hydrogen of the water and liberates the oxygen, which is then said to be "nascent," and in that state combines with the vegetable tissues of moulds which may be present, and cause their destruction.

3rd.—Another method, which also answers well and is applicable to tubs and open vats, consists in carefully washing, scrubbing, and whitewashing inside with a limewash made of two pounds of quicklime to every 100 gallons capacity of the vessel, just sufficient water being added to reduce it to the consistency of thin paint, viz., about two gallons. The limewash is left to stand and dry for a few days, and is then washed off. A small quantity of sulphuric acid added to the water will help in dissolving the lime inside the casks where the brush cannot reach.

4th.—The following method, too, I have often advised, and whenever it has been practised no taint has spoilt the wine through bad caskage, viz.: The empty cask, if a large one, has its door removed, a man gets in, and a couple of bucketfuls of water are thrown into it; with a straw broom the inside is scoured all round and the dirty water swept out into a tub placed below the manhole to collect it.

If there are indications that the cask is sour or mouldy, a gallon or two of a solution of sulphuric acid one part, in water twelve to fifteen parts, is carefully poured into the cask—the acid being poured into the water, and not the water on to the acid, which would cause splashings—and with the long-handled broom the cellarman, using every precaution not to get splashed by the acid, rinses every part of the inside of the cask. I would caution any raw hand at that kind of work against using the acid at all, and applying instead some simpler, if not as efficacious, method of disinfecting the casks. This is followed by a couple of bucketsful of hot water in which a few handfuls of washing soda (one pound per gallon of water) are thrown, for a 500-gallon cask, or a little more for a 1,000-gallon vessel. With the aid of a hard brush—some very serviceable hard brushes for scrubbing casks, made of steel wires and coarse fibres, will be found useful—both heads, as well as the interior of the casks all round, are thoroughly scrubbed. By the time the scrubbing is done the water looks very dirty and of a washy coffee colour, especially if the cask has previously contained red wine. This dark wash is, in its turn, swept out of the cask, and two fresh bucketsful of hot water and soda are thrown in, the operation of scrubbing being repeated. This wash having been swept out, the cask is well rinsed with clean water, then allowed to drain and dry. The next day a piece of sulphur rag is burnt in it, the door greased, replaced and screwed well home, and the plug driven in. Care should be taken to save the hands from contact with the caustic soda or acid washes recommended.

Other methods consist in using for a hogshead, 2lbs. caustic soda in one gallon water; roll and let stand on end for one hour or two, and roll several times again.

Soda has a great affinity for acetic acid and the resulting acetate of soda thus formed is readily soluble in hot water used for rinsing.

#### SULPHURING CASKS.

Sulphuring should be repeated every two months or so if the cask is left empty. Should the cask be wet at the time of sulphuring, hydrogen sulphide would be produced, which would impart to the wine an abominable smell of rotten eggs.

The object of sulphuring casks, as all those who have any experience of cellar work know, is to consume all air out of them and thereby check the appearance of the germs of acetic fermentation and other diseases of the wine which are dependant on the oxygen in the air for life.

#### SLACK CASKS.

When overhauling empty casks stored away in a hot, dry shed, sometime before vintage, they are generally slack from being empty for a long time; the staves have shrunk, and the hoops have either fallen off or will do so unless the casks are carefully handled.

When casks thus get slack, the sulphur fumes they contained escape and dissipate into the air, and moulds not infrequently penetrate, and grow in patches inside as well as between the staves. Such casks should be treated as explained when dealing with mouldy casks.

The hoops of these slack casks must be driven before the casks are cleaned. This must be done cautiously, or else when the cask is filled with wine the expansion of these shrunken staves and the head of the cask will be such as to buckle and warp, or the strain on the hoops is so considerable that they occasionally snap and much wine is lost before the contents can be saved. For this purpose drive the hoops lightly to prevent the cask falling to pieces, put a bucket of hot water into it; this hot water will often run out of the vessel in a short time; repeat the operation, and the leaks will soon take up. It is only occasionally that the hoops have to be driven hard.

#### FLAGGING.

After a while the staves of casks shrink as also do the heads, but on account of their larger superficial area the staves shrink more and driving the hoops does not suffice to make the casks tight. It is then necessary to insert between the staves at each head flat reedy leaves to fill up the open interstices. When this shrinking

becomes excessive it may be necessary to re-cooper up the cask and replace one or more staves, removing one or more and substituting in their places wider ones so that the heads can then sit well home in the grooves and make the cask tight. Sugar-bag matting is often used; it is first moistened to make it limp and prevent breaking, and is then split into two faces before using. The flagging is done with the help of a flagging iron, by means of which the end of the staves at the head are pressed apart. For that purpose, the two top hoops are taken off, and the third hoop may have to be loosened, just enough to save the head falling through. It is a good plan to mark beforehand with a pencil or with chalk the leaky spots.

For a longitudinal flag, press out one stave and insert the split flag lengthways, double it if the fissure is large, and let the lower end of the flagging material come out where a hoop will cover it.

For a circular flag, around the rim of the head piece, put in the moistened flagging material one stave at a time, using for so doing the flagging iron and also a blunt hard wood wedge.

For a leak between head and chime, the flagging material is carefully inserted into the groove of the stave.

#### CRACKED STAVES.

Repeated use of the cask often damages one or more of the staves or the bung hole. If the bung hole is slightly splintered but not quite unsound, carefully drive down a bung, and treat like a cracked stave. For that purpose, first work a little white lead into the crack, then place a piece of brown paper over it, and cover the brown paper with a piece of sheet lead cut the required size. Instead of white of lead, a paste made by boiling a little linseed is used, and this is covered as described. The sheet lead is tacked round, all creases being carefully hammered out, commencing at one end and proceeding to the other, as the tacking is done. The tacks of course should not be too large. Equal parts of beeswax and resin make a good mastic.

#### KEEPING WOODEN VATS IN GOOD ORDER.

During the period which elapses from vintage to vintage wooden tubs and vats are idle and shrink, although whitewashed, and this must give trouble when vintage comes on again.

Some wine-makers fill them with water which keeps them together, but the water often rots and taints the wood—unless made into brine or permanganate of potash is added. A method which finds favour with some is to first well dry the tubs and vats, after thorough cleansing, and then paint them over with melted paraffin

wax, which is then burnt in with a plumber's lamp, starting from the lower part of the vertical walls. This fills the pores of the wood and prevents shrinking, and at the same time gives an even and uniform coat. If the tin containing the molten paraffin be placed in a bucket of hot water, the substance will keep fluid longer.

To preserve the staves, rub or paint with boiled linseed oil, then pick out the hoops, painting them with boiled linseed oil with one quarter gold size added to make them dry quickly.

#### BRICK AND CEMENT VATS.

Of late years wooden vats have been discarded in the more modern fermenting sheds in favour of cement vats, which offer marked advantages. Their initial cost is from one-third to one-half that of the wooden vessels; they occupy less room in the fermenting shed and thus constitute an economy of roof surface; they are easier to keep sound and sweet, and are less likely to taint wine, while they do not shrink, rot, or burn.

Vats, rectangular in shape, with an inside dimension of 5ft. x 5ft. x 4ft., and the angles rounded, would have a capacity of a little over 600 gallons, and would in practice ferment 500 gallons of wine. Another convenient size is 6ft. x 6ft. x 3ft. 6in., giving a capacity of 787 gallons.

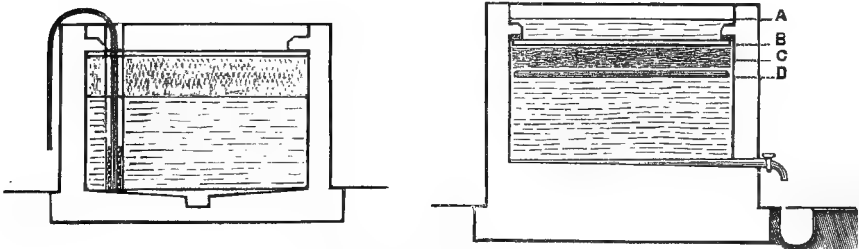

Two types of Cement Tanks.

A good deal of care is required in their construction: bricks, clean, coarse sand, and cement are the only material required, no lime being used for setting the bricks.

No very substantial foundation is required; the top soil on the floor of the fermenting shed is simply scooped out with the spade; a 9-inch brick wall is built all round the space to be covered with the cement vats, and if resting on clay, which expands and shrinks very perceptibly according as it gets wet or dry, it is advisable to spread a layer of clean dry sand, two or three inches thick, within



that space and ram it well down. The surface having been made smooth, spread the cement, set the bricks and grout with liquid cement mortar made of cement one part and sand two parts..

Both sand and cement must be sifted, and the mortar must be very liquid. Over this foundation build up a single-brick-thick work— $4\frac{1}{2}$  inches—to the height required. Round off the angles and corners inside, and have the floor sloping from every direction into one corner.

This favours the drainage of the liquid, which can be bailed out with the dipper, and dried with a sponge. Before the cement is quite set it is found advisable to blow dry cement and rub it in so as to give a smooth polish to the surface. For that purpose use a wood float and finish off with a steel trowel. The top of the walls is also capped with cement.

At intervals, on the top of the walls, small brackets are provided, which help in making fast the false head which keeps the rials or skins and seeds submerged. Instead of having the bottom slope converging to one point inside into a cup or pit, a two-inch brass tap is sometimes inserted into the wall, flush with the lowest corner, and the liquid can be run out, without pumping or syphoning, which the other alternative would necessitate. In that case a small cement gutter with a gradual fall towards an underground tank, whence it is pumped out, is provided along the line of vats. Although this appears to be a convenient method of emptying the vats, yet some object to it on the ground that there may be a danger of the taps getting knocked out and causing a leakage, or of the underground tank requiring frequent and careful cleansing, thus involving extra work.

The quality of the cement used is not immaterial. Of these there are two kinds—the “quick-setting” and the slow-setting” cement. The former are generally natural cements, containing variable proportions of lime; whereas the slow-setting cements are generally artificially manufactured with definite proportions of lime, which varies from 58 to 63 per cent., and are burnt without excess. It is said that this regularity of composition, and the way they are manufactured, insures their more lasting properties. Slow-setting cements containing less lime than some of the quick-setting ones, all the lime is taken up by the clay and transformed into aluminate of calcium, and no free lime is left uncombined, which would, in contact with wine, rob it of some of its natural acids and cause it to go flat.

When cement vats are used for storing wine, a roof is provided in the shape of a vault, and a manhole made of cast-iron, with a tight-fitting door, is set in the structure. It is also sometimes advisable to line the inside with glazed glass tiles. The St. Gobain

Company, near Paris, manufactures for this purpose glass tiles 4 to 6 mm. in thickness and 24 cent. by 24 cent. The side which is against the cement is striated, to better hold to the cement, whilst the other side is smooth. For the floor, larger and thicker tiles are used. These tiles are set in soft cement mortar, and care should be taken not to allow any air to remain between the cement and the tile, which should be soaked in water before using.

Apart from these brick and cement vats, some are constructed of a combination of iron and cement, or ferro-concrete, and are extensively used in Algeria. They are known as *sidero-cement vats*, and consist of a framework of iron rods, either rectangular or cylindrical, as desired. On this iron lattice-work, which has the shape of the vat, cement mortar is plastered, and the desired polish is given to the surface.

These vats are thinner than the brick ones, whilst their cohesion is much greater, for although cement can stand a considerable crushing strain, it lacks in cohesion, or in other words, its tensile strain is not so great.

In Algeria, where these *sidero-cement vats* are in great favour, the cost was set down some years ago as ranging between 2s. 6d. to 3s. 4d. per hectolitre (22 gallons) for small vats, and less for larger ones. These prices are equivalent to 1¼d. to 1¾d. per gallon, wooden vats costing 8 francs per hectolitre or 3¾d. per gallon.

The combination of the iron and the cement, instead of being an element of weakness, considerably adds to the strength and durability of the vats. Both these substances expand or contract at the same rate, and therefore no dislocation ensues, whilst, on the other hand, the close-fitting cement covering effectually preserves the iron from rusting.

When these cement vats are made, and dry, they are first filled with water, and although they may sweat a little at first, this soon stops.

It is necessary before using these vats to also wash them with some solution which will dissolve and neutralise the traces of lime which may be left close to the surface, viz., a weak acid wash, such as a 10 per cent. solution of tartaric acid, or of sulphuric acid; a protective coating of tartrate of lime or of sulphate of lime is thus formed.

Fluoride of magnesium, 20°—25° Baumé, is applied with a brush, two or three times, with an interval of 12 hours between each, until the cement has absorbed about 14ozs. per square yard. When dry apply a single coat of fluoride of aluminium at 15° B., using 7ozs. per square yard. After drying wash with water until the salty taste of the fluoride has gone. The vat may then be used without risk.

Another wash, much used in the South of France, is one of silicate of potash. A first application of a solution of 25 per cent. of this substance is applied with a brush, and after two or three days, when quite dry, the walls of the vat are washed with fresh water; when dry, the inside of the vats again receives a second coating of a 50 per cent. solution of silicate of potash, and is left to dry for a few days, when the vats are again thoroughly washed with water. A coating of silicate of lime, which is unattackable by wine, then lines the vat.

As an improvement on the brick and cement vats already described, it would, I believe, tend to strengthen the structure and prevent possible cracks to run a thin band of galvanised hoop iron between each alternate course of bricks.

#### CRUSHER AND STEMMER.

As the grapes are carted to the fermenting shed they are transferred from the boxes or the barrels in which they were placed at

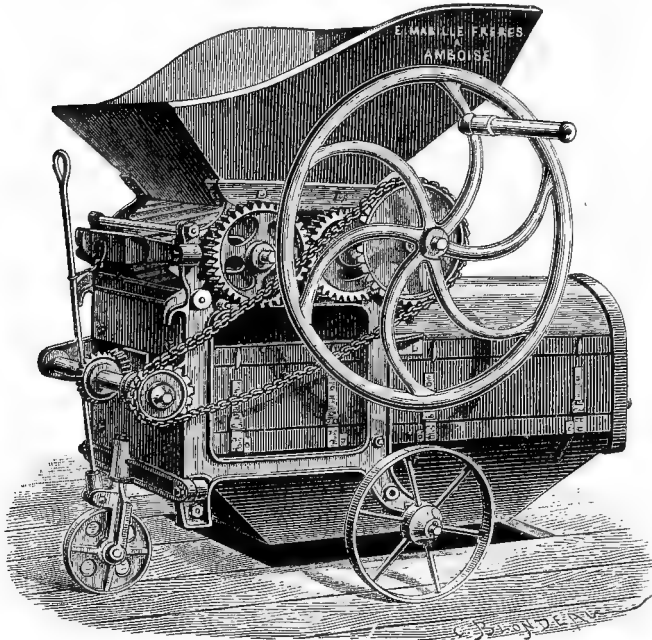

Stemmer and Crusher.

the vineyard into the crusher. In the old days of wine making crushing was done either with bare feet or with the feet shod with specially constructed boots or wooden sandals. Since then

great progress has been achieved in the direction of reducing the grapes into a pulp by modern machinery makers.

The following illustrations show two types of an excellent stemmer and crusher, of French make, which have been copied with more or less success by both American and Australian makers. As regards efficiency, workmanship, and durability they are, however, superior to many I have seen at work.

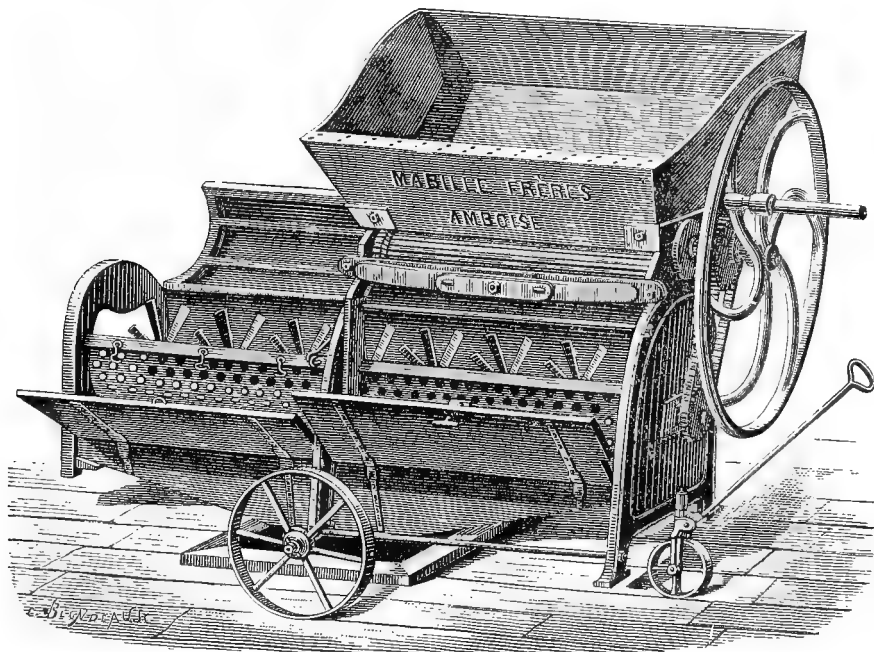

Grape Stemmer and Crusher.

No. 1 Mabile crusher and stemmer, which is the smallest model made, can be worked with ease by one man, and puts through about two tons of grapes within the hour. These grape-crushers can also be provided with a pulley for working the machine by motor if required. The cost was in pre-war days £18 at the factory exclusive of packing, railway and shipping freight to Fremantle, and duty, which would amount to another £12 or so.

Several devices are used for conveying the grapes from the dray to the crusher, which it is often found convenient to have at such a height above the ground that the crushed grapes will run by gravitation along a chute into the fermenting vats. The simplest, but most costly in the first instance, is an elevated

roadway, which will take the cart up to the level of the grape-mill. A less expensive way is to have a grape elevator, which consists of a piece of belting about 10 inches wide, with tin buckets or scoops fastened at intervals of a foot or so, and running inside a wooden box at an angle of 45° to 60° to the height of the grape-mill hopper, where each bucket empties its contents. A 4 to 6 h.p. motor would afford ample power for working both elevator and crusher and stemmer.

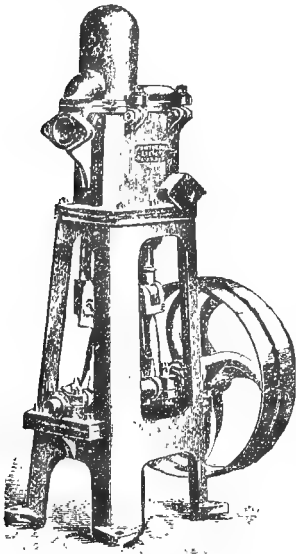

Grape Must Pump.

Another mechanical method for lifting the grape pulp and conveying it into the fermenting vats is a specially constructed must pump constructed by Victor Coq, of Aix, near Marseilles. This pump is unchokable, and pumps over 2,000 gallons of must and skin per hour. It is easily cleaned, and takes but little space, but it is essential that it be carefully cleansed, after using, of the grape must slime, which coats it every day.

Another mechanical method for lifting the grape pulp and conveying it into the fermenting vats is a specially constructed must pump constructed by Victor Coq, of Aix, near Marseilles. This pump is unchokable, and pumps over 2,000 gallons of must and skin per hour. It is easily cleaned, and takes but little space, but it is essential that it be carefully cleansed, after using, of the grape must slime, which coats it every day.

#### WINE PRESSES.

Conjointly with the grape crusher, one or two wine presses are required in the fermenting shed. A variety of designs are found to effect the mechanical separation of the juicy from the solid parts of the grapes. The simplest, probably, is the long beam or lever press which presses continuously.

More convenient is the screw press, an illustration of which is here given, on account of its powerful leverage, the rapidity of its work, the simplicity of its mechanism, and the ease with which it is operated.

After the dry summer months preceding vintage, the timber forming the wooden tray has shrunk more or less, and the screwing of the nuts of the bolts running through it, together with applications of hot water over bagging spread over the woodwork, become necessary. Should the leak, however, persist, and cracks have formed in the wood, they may be filled with a putty compound of melted resin with a little tallow and fine ashes, which is applied hot. This cement will stop leaks in presses and casks which may have proved refractory to other means. Some hot paraffin wax run into the cracks also answers the purpose.

The cost of a No. 4 Mabile press as illustrated below, with a 6ft. x 6ft. cage, was, before the war, £25, with another £15 added for packing, railway and shipping freight to Fremantle, duty, and other charges.

Continuous presses with a strong compound screen are also made; they give a greater extraction of juice, and require motor power for working.

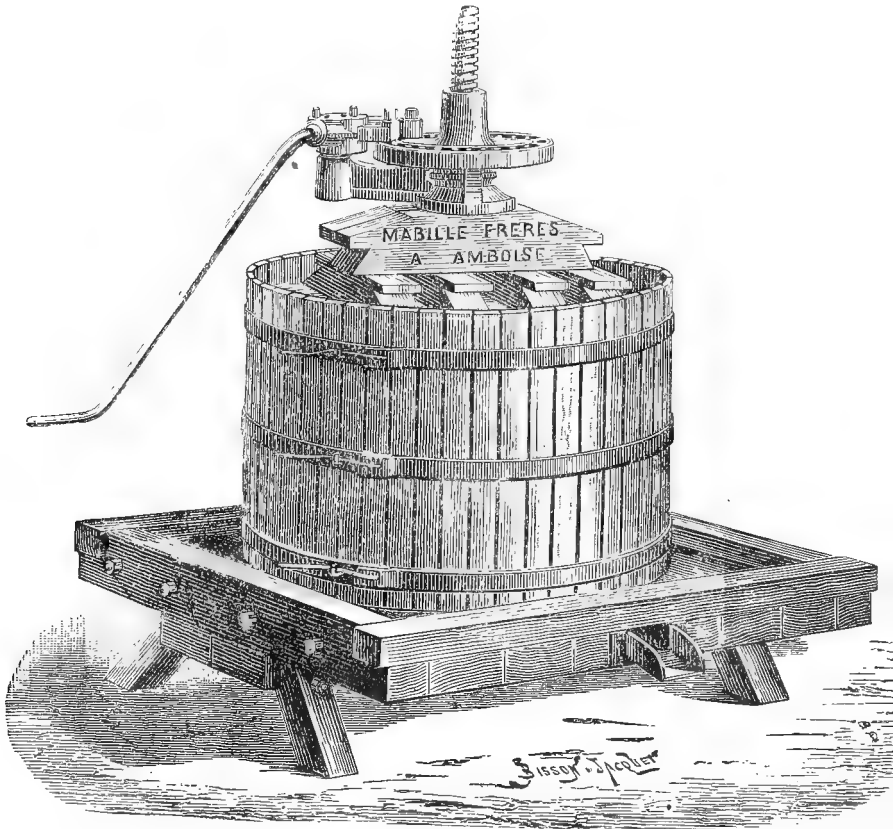

Screw Press.

Hydraulic presses are also used in many wineries, and save labour.

#### WINE FERMENTATION.

Wine fermentation is the process during which grape must, which is the fresh juice of the grapes as it runs from the press, is transformed into wine.

This process is governed by many outside influences, which it behoves the wine maker to watch and direct.

Grape must contains not only all the soluble parts of the grape, but, depending upon the amount of care exercised in its preparation, it contains, as well, other substances which get into it by accident, such as the impurities adhering to the outside of the skin, some of the grape pulp, parts of the skins and seeds.

It is well to know something about these component parts of grape must, and a look at the following section of a grape berry will convey some amount of information about its structure.

The nourishing sap flows into the grape berry through the peduncle from the plant, and there, mainly owing to the influences of sun and light, these materials are gradually transformed into various bodies.

The vessels which convey these nourishing fluids converge at the peduncle, then diffuse through the body of the berry, leaving, wherever they reach, the requisite amount of material. From this other fibrous vessels branch out, which convey nourishment to the skin.

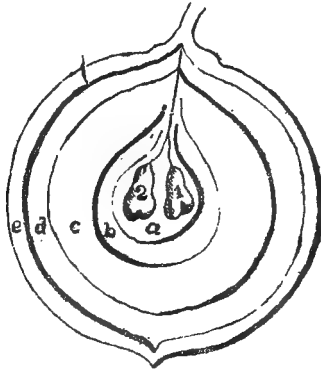

Section of a Grape Berry.

From the peduncle, two small threadlike vessels proceed to the seeds *a* (1 and 2), and, as the grape berry ripens, assume a rusty violet colouration.

Around the pips (*a*) is the zone (*b*), which contains very little sugar, and mostly viscous albuminous substances, free acids, and cream of tartar.

The layer *c* contains mostly water, sugar, and small quantities of acids and albuminoid matters.

Section *d* is richer in sugar and more fleshy, and contains gummy substances, which, during the process of maturation, are

transformed into sugar; a small amount of acids and albuminoid substances are also met with there.

Layer *e*, which underlines the pellicle, contains the colouring matter, also tannic acid, and some aromatic substances which impart a peculiar flavour to certain grapes, such as the Muscats, Riesling, Cabernet, Isabella, and other American grapes. These natural aromas are quite distinct from those ethers which constitute the bouquet of matured wines, and which are the result of chemical reactions between the acids and the alcohol in the wine. The colouring matter, or *onocyanine*, although generally lining the skin of grapes, is occasionally found in the pulp of some varieties. There are two distinct sorts—a yellow and a blue one—which, when in contact with the acids in the wine, turn red.

As grapes ripen, there is a gradual migration of the sugar from the centre towards the circumference, where it accumulates under the skin. This explains why, when pressing grapes which are dead-ripe, the juices which run out first are not so sweet as those which flow when greater and more prolonged pressure has been applied.

The following table gives the composition of fresh grape must and of the resulting fermented wine:—

Must.		Wine.	
	%		%
Water ... ..	73-86	Water	
Albuminoid matters ...		Residues of albuminoid matters	
		{ Glucose chiefly levulose	
		Alcohol ... ..	6-14
Glucose (chiefly dextrose)	12-24	Glycerine ... ..	0.5-1.5
		Succinic acid	
		Acetic acid	
		Ethers	
Gum		Gum	
Vegetable mucus		Colouring matters	
Colouring matters (traces only)		Tannin	
Tannin (traces)		Malic acid in (bad seasons)	
Malic acid (in bad seasons)		Tartaric acid	
Potassium hydrogen tartrate		Potassium hydrogen tartrate	
Calcium tartrate		Calcium tartrate	
Other salts of organic matters		Other salts of organic matters	
Mineral matters ...		Mineral matters	
Sp. gr. ... ..	1065-1107	Sp. gr. ... ..	.991-.996
Total dry residue ...	14-27	Total residue ... ..	1-3%



## COMPONENTS OF MUST.

It is thus seen that grape must is a complex liquid.

*Water* stands foremost at the head of the list as regards quantity. In must of average composition it enters for about three-quarters to eight-tenths of its weight. It acts as a vehicle of the other constituents, diluting them to the required degree, and bringing them all intimately together.

Sugar, for instance, produces alcohol in fermenting, but in order to ferment it must be considerably diluted, as, if too much concentrated, it acts on the reverse as an anti-ferment, as is illustrated in the case of fruits preserved in syrups. No liquid will ferment that contains more than half its weight of sugar.

*Sugar*.—Next to water, sugar is the ingredient found in largest proportions in the grape mash. It enters for about one-fifth to a quarter of its weight, and sometimes more, running up in dry seasons, and in over-ripe grapes, to nearly a third of the weight of the must. That sugar is of a peculiar kind called "glucose," and consists of a mixture, in about equal proportions, of grape and fruit-sugar, known to chemists under the names of "dextrose" and "lævulose."

The chief characteristic of glucose, or uncrystallisable sugar, compared with cane-sugar, or "saccharose," is that the former can ferment, whereas cane-sugar, in order to ferment, has previously to be turned into glucose.

Another characteristic is that while cane-sugar can be turned into glucose, this latter form of sugar has never yet been changed into crystallisable sugar. The invention of a process that would achieve this would be worth more than all the mines of this country put together.

During the process of fermentation, "dextrose" is the first to be acted upon by the yeast; and if the wine is badly fermented, and remains sweetish, it is "lævulose," which is found to have remained unchanged.

During the process of fermentation the constituents of glucose, properly diluted, are split up into substances differing from it, both in their physical and in their chemical properties, the products of fermentation being *carbonic acid gas* and *alcohol*, besides other bodies such as *glycerine* and *succinic acid*, which occur in small quantities, and which vary in some measure with the vat temperature during fermentation: the glycerine giving mellowness to the wine, while the succinic acid gives it that peculiar taste known as "vinosity."

*Acids*.—Besides these two important ingredients, viz., water and sugar, the must of the grape contains small proportions of acids, such as tartaric acid, which occurs to a large extent in the vegetable kingdom; malic acid, or the acid found in apples; and tannic acid or "tannin": and cream of tartar, which is an acid salt.

The presence of these natural acids in must is most important. A due proportion ensures a sound fermentation, being beneficial to the healthy growth of the pure wine yeast, and injurious to that of germs of maladies. Good fermentation ensures good keeping qualities. Acids also fix the colour of wines, which otherwise would by degrees be cast in the lees. Too much acidity, however, makes the wine tart and raw; too little makes it mawkish, and causes it to get flat.

The right amount of acidity in must varies according to the class of wine. Its measure is sometimes expressed as equal in strength to sulphuric acid, and sometimes to tartaric acid, and as authors seem to use these two standards indiscriminately, it is useful to bear the following rule in mind:—

To convert sulphuric acid into tartaric acid,  $\times 1.53$ .

To convert tartaric acid into sulphuric acid,  $\times 0.65$ .

Thus, must producing the best claret or light wine contains acids equivalent to 4 to 6 *pro mille*. of sulphuric acid, or 6 to 9 *pro mille*. of tartaric acid.

Heavy *sweet* wines are made of grape must showing an acidity of 3 to 4 *pro mille*. expressed as sulphuric acid, or 4.6 to 6 as tartaric acid.

*Brandies* of the best kind are generally made of wines rather high in natural acidity, and manufactured from must going 6 to 9 *pro mille*. as sulphuric acid, or 9.2 to 13.8 as tartaric acid.

Should the acidity fail to come up to the standard desirable for the class of wine to be manufactured, it is not only permissible but advisable to supplement the difference by—

1st. An adequate addition of pure crystals of tartaric acid.

For this purpose every 1 per mille. may be calculated as 1lb. per 100 gallons of must. Thus, if a shiraz or a malbec shows 5 per cent. of must acidity, calculated as tartaric acid, it is desirable, to bring that must up to 7 per cent., to add 2lbs. of tartaric acid crystals for every 100 gallons.

For that purpose it is best to sprinkle the acid crystals over the grapes as they come out of the crusher.

The tartaric acid then combines with the potash salts in the must, and, after it has directed its influence in a beneficial manner during the course of fermentation, it settles down as tartar.

Some wine makers prefer, when it is found necessary to raise the degree of acidity of a must, to use a mixture in equal parts of cream of tartar and of tartaric acid. The resulting wine is less astringent and raw.

The belated addition of tartaric acid to made wine fails, it is obvious, to have a beneficial influence on the fermentation, and imparts to the wine a raw and acerb taste.

Other means besides the use of tartaric acid are followed by some wine makers in order to bring their grape must up to the desired standard of acidity, and that is—

2nd. By an admixture of second-crop grapes.

3rd. By early picking.

One more word on the question of acidity in relation to must and wine, and that is, that authors generally, when treating of the acidity in made wine, refer to it in terms of sulphuric acid. The rule given above will enable anyone to convert it to tartaric acid, if so desired.

Without the acids, wine would be a mere mixture of spirits and water, of a dull leaden colour, without any flavour or bouquet, and almost tasteless to the palate. The presence of natural acids in wine gives it, on the other hand, a brilliant and sparkling appearance, owing to their action on the colouring matter in wine; besides, by combining with the alcohol, they create those penetrating and delicate ethers which have very appropriately been called the "bouquet" of the wine.

*Saline* substances are also found in musts, as potassium salts, under various states of combinations, and chiefly among these is acid tartrate of potash. That salt, commonly known as "argol" or "tartar," adds to the acidity of the must and of new wine. It is less soluble than tartaric acid in water, and its solubility decreases, while the percentage of alcohol goes on increasing. It precipitates in large quantities in the lees after fermentation, and after the first drawing off it deposits slowly, under the form of crystals, on the inside of the casks.

It often happens that young wines, possessing a raw and unpleasant acid taste, improve considerably on maturing, and lose that excess of acidity which is due to the tartar.

Although that salt precipitates gradually in a liquid which contains alcohol, that precipitation is further accelerated under the influence of cold; hence the practice of maturing wine completely fermented, especially light wines, with a low percentage of alcohol, and with a marked degree of natural acidity, in cool, underground cellars. The French have a characteristic word for depicting that gradual process of precipitation of the tartar and the lees. They call it *dépouiller*, which means to eject, or excrete the dregs.

*Colouring matters* and *essential oils*, such as produce the "aroma" in wines, are other ingredients of the must. Both are contained in cells which line the inner face of the skin, and their extraction is made more active and more complete under the influence of warmth and the production of alcohol during the course of active fermentation.

Temperature notably influences the solubility of the colouring matter; alcohol does so to a much lesser extent. This explains why those wines which have been subjected to a fairly high temperature

during the process of fermentation are deeper in colour than those fermented at a cooler temperature. If moderate temperature helps in dissolving the colouring matter of grapes, it causes it, if carried on to a higher degree, to undergo an alteration which brings about its precipitation.

An instance of this is afforded by wines which, during the process of sterilisation by means of heat-process, known as pasteurisation, has been over-heated. That point is reached at about 70° C. (158° F.), and for that reason it is desirable not to go much above 65° C. (149° F.).

Each variety of grape has a special pigment of its own, peculiar to itself.

*Albuminoids* or nitrogenous substances, resembling the white of an egg, also occur in minute quantities, viz., .1 to .4 per cent., and are important. To a certain extent, therefore, they are essential to fermentation, but when constituting a surplus their presence in wine is highly undesirable, and even dangerous, as they are very unstable bodies, easily decomposed, causing many of the accidents and diseases which occur in wines.

Certain grapes, such as the Riesling, various white grapes, and also Muscats, often contain a surplus of these albuminoid bodies, and, especially so, grapes that mature very quickly, as in hot climates; and this is the case generally with grapes grown in Australia.

Such surplus albuminoid substances should be removed by all possible means, in order to insure the safe keeping of wines; and in a subsequent paragraph I shall mention the object of aeration in this respect.

Another means we have of ridding white wine must of any surplus albuminoid matters is to let it stand still for a day or two, and then draw the clear liquid from over the muddy and viscous deposit just as the first indications of fermentation become noticeable. In order to better effect this end in warm climates, where fermentation starts very shortly after the grapes are crushed, the liquid is treated with sulphurous acid fumes. Thus the must is impregnated with the fumes of burning sulphur, or liquid sulphurous acid in small quantities is poured into it, or such salts as sulphite of potassium is added to it. The advantage of these last-named methods over the first consist in the greater precision which can be obtained in the matter of the dose used, and in the greater convenience as well.

#### WHEN TO PICK GRAPES.

In old-established districts experience has shown when it is best to pick the grapes; and at such places it is seldom that the date of vintage alters more than a week or so from the customary epoch for picking the different kinds of grapes grown.

In other parts the vine-growers will have to depend, to a greater extent, on other indications for determining the time when to begin picking. These indications, although empirical, are sufficiently reliable.

They are afforded by the appearance of the bunch itself. The stalk becomes woody, and loses its tender green look; the berry is sweeter when pulled off the bunch, and parts easily from the bunch or bundle of sap vessels which bring nourishment; and the skin becomes leathery.

More reliable ways, however, which any vine-grower can readily use, are obtained by physical or by chemical tests.

The *physical* test is obtained by means of a light instrument capable of floating into the liquid, and called a "densimeter," which gives, on a graduated spindle which projects out of it, specific gravity readings, or such readings which convey to the mind of those who use them the information they require. Thus, the instrument is called a "saccharometer," by wine-makers and sugar manufacturers, "lactometers" by dairymen, "hydrometer" or "alcoholometer" by distillers, and so on.

The principle on which saccharometers are constructed is that the smaller the proportion of sugar, the deeper the instrument will sink. This method is not always exact, for the reason that grape must is not only a simple solution of sugar and water, but contains minute quantities of other substances as well, which cause slight errors—errors, however, which in practice may well be overlooked.

In Australia, confusion reigns supreme in the returns furnished by wine-makers as regards the strength of the must from grapes grown in different localities. Some will give the specific gravity; others, degrees Baumé; others, again, percentages of sugar; while some will mention so many degrees according to Hicks' hydrometer, Keene's (also called Hunter River) saccharometer, and a few will quote the brewer's saccharometer.

It is easily understood that the work of collating returns recorded according to so many different systems becomes very complicated, not to say impossible; and it would be highly desirable that all the Australian wine-growers should, as it is done in France, Italy, and the wine-producing countries of either Europe or America, settle on a definite scale for the purpose of expressing the richness of their must in sugar. For that purpose either the specific gravity of the liquid or the reading of the Baumé hydrometer are used.

These hydrometers are made either of metal or, preferably, of glass, and consist of a long, slender spindle, surmounting a larger tube of blown glass, to which is soldered at the lower end a glass bulb, containing, as ballast, either mercury or small shot, for the purpose of maintaining the instrument in an erect position in the liquid, page 428. The lighter the liquid, the deeper the instrument

sinks; and the heavier the liquid, the more of the spindle appears above the surface of the liquid.

Within the glass spindle is a scale, which varies with the make of the instrument. Some are so graduated that the operator can read at a glance either the specific gravity, the percentage of sugar, degrees Baumé, degrees Brix, according to the special purpose for which the instrument has been constructed.

I shall rapidly explain the three scales most in use for the determination of saccharine liquids.

1st. *The Specific Gravity Scale.*—The best known is Gay Lussac's centesimal densimeter, on which 1,000 represent the depth to which the instrument would sink in pure water at the temperature of 15 degrees C. (59 degrees F.). According to the law formulated above, the divisions above 1,000 indicate densities lower than that of water, as, for instance, oil, spirits, etc.; while the divisions lower than the 1,000 of the scale represent the specific gravity of liquids heavier than water, and also the weight in grammes of one litre of the liquid tested: thus 1,080 means that the liquid is to pure water as 1,080 is to 1,000, or, in other words, that one litre of the liquid weighs 1,080 grammes, as compared with the same capacity of pure water, which weighs one kilogramme—in other words, 1,000 grammes.

In most saccharometers the 1,000 is placed at the top of the scale; as the liquids weighed get heavier than water, more of the spindle appears above the surface of the liquid.

#### SUGAR TEST BY SACCHAROMETER.

If great accuracy is required, it is necessary to make a slight correction when the specific gravity is taken at temperatures below 15 degrees C., or above that degree of temperature, thus:—

If the temperature is—

degrees C.,	take off	·6	from the reading
11	”	”	·5
12	”	”	·4
13	”	”	·3
14	”	”	·2
15	”	”	·0
16	”	add	·1
17	”	”	·3
18	”	”	·5
19	”	”	·7
20	”	”	·9
21	”	”	1·1
22	”	”	1·3
23	”	”	1·6
24	”	”	1·8
25	”	”	2·
26	”	”	2·3
27	”	”	2·6
28	”	”	2·8
29	”	”	3·1
30	”	”	3·4

The temperature of liquids influences their gravity. They expand by heat and contract by cold, and consequently their specific gravity are increased by the latter and diminished by the former.

Thus a grape must whose weight is taken at a temperature over 15 degrees C. or 60 degrees F. appears lighter than it really is; therefore the reading should be forced.

Spirit, on the other hand, at a temperature higher than normal appears lighter in weight; that is to say, higher in strength, and a deduction is made to correct the error.

As grape must contains other substances beside sugar, the real sugar contents will be from .5 to 2.5 per cent. less than the indicated per cent. or degree on the saccharometer. As seen above the specific gravity of the juice also varies with the temperature; for this reason bring the temperature of the juice to the standard 60 degrees F., or make the corrections of .1 per cent. for every 3 degrees F. above or below standard by adding if the temperature is higher or by subtracting if it is lower.

2nd. The *Baumé Scale*, which is determined by marking as 0 degree the point on the spindle of the hydrometer to which it sinks when floating in pure water, and as 15 degrees the point to which it sinks in a solution of 15 parts by weight of salt in 85 parts of water. The interval between these points is divided into 15 equal parts, and the scale is continued to any number of degrees beyond.

This scale is also very much in use in many branches of industry. It does not give the density by direct reading, but the density can be ascertained either by reference to tables, or by means of the following formula, in which  $n$  represents the degrees Baumé as read on the scale, and  $D$  the specific gravity required:  $D = \frac{144}{144-n}$ . Thus, 10 degrees Baumé equals  $\frac{144}{144-10}$  or 1.075 specific gravity. The graduation of the Baumé hydrometer is somewhat arbitrary, and its use has only been maintained in practice by wine-makers owing to the fact that, by a curious coincidence, degrees Baumé, in an unfermented must, also approximately indicate—as may be ascertained by referring to the subjoined table—the percentage of absolute alcohol by weight it will have after being subjected to a complete fermentation. Thus, page 430, a must measuring 11 degrees Baumé, will give a wine which will contain very nearly 11 degrees of absolute alcohol.

When these instruments are constructed for testing the strength of saccharine liquids, the 0 degree is, for reasons previously given, placed at the top of the scale.

THE GUYOT GLUCOMETER

shown in the drawing presents the advantage of enabling us to read under three different forms from one observation, giving the richness of sugar expressed per cent., the degree Baumé, also called liquor degree, and the quantity of alcohol after complete fermentation. In practice, however, this quantity, which is calculated on the basis of the theoretical chemical equation, is .8 per cent. or nearly 1, too high.

3rd. *The Scale of Brix, or Balling*, as it is also called, is mostly used by sugar makers. It gives the per cent. of sugar present in any given solution. For example, a solution marking 14 degrees Brix contains 14 per cent. of sugar with other extracts in solution. In grape juice 1 to 2.5 should be subtracted for extractive matter.

The illustration of Keene's (sometimes called Hunter River saccharometer, from the locality it was mostly used in Australia) is based on the pattern of Guyot's glucometer. It shows, on a tricolour scale, the specific gravity of the must, the percentage of sugar corresponding to that specific gravity, and the amount of alcohol which would result if the liquid was thoroughly fermented.

It consists of an ordinary hydrometer, about 12 inches long. The scale is divided into three longitudinal columns, giving—1st, the specific gravity; 2nd, the degrees Baumé, corresponding to the degree of density; and 3rd, the per cent. of sugar, corresponding to each one of these degrees. The intervals between the divisions should be pretty wide, so that the wine-maker can see at a glance what is the specific gravity of the must, how much per cent. of sugar the must contains, and, by interpreting the degrees Baumé into the number of degrees of absolute alcohol, what will be the approximate strength of the wine which will be made from that must, after thorough fermentation.

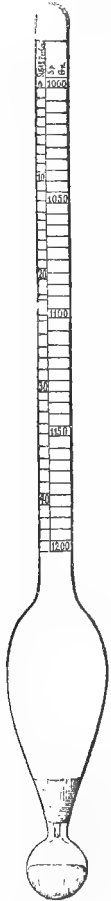

Saccharometer.

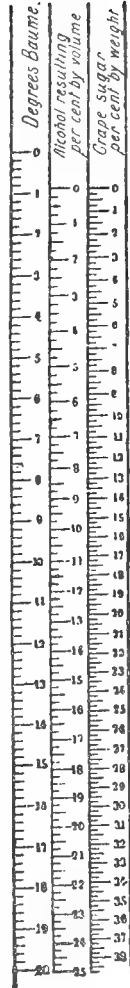

Scale of Guyot Glucometer.



The reading of the tests taken during vintage, duly recorded in a register, will supply valuable information respecting the character of the must of grapes grown from different varieties on different soils in different districts, and will permit of interesting comparisons being drawn with the must of previous years.

*Chemical Test.*—As already seen, the empirical as well as the physical means we have of ascertaining the richness of grape must is in practice found sufficiently correct, although not absolutely so. It is to laboratory tests we must rely for an exact determination of the contents of a must in either sugar or acids, and as these tests are not readily made by the majority of wine makers, I refrain from referring to them at length.

#### ACIDITY IN WINE.

In hot countries particularly, ripe grapes very often lack somewhat in acidity, and it is not unlawful but even advisable to bring this acidity up to what it should be by the addition of tartaric acid. This ensures a healthy fermentation when that other important question of temperature is carefully regulated. The more natural acidity in a grape must, the greater difficulty ferments other than alcoholic will find in developing. Experience shows that 7 to 10 grammes of tartaric acid per litre (.7 to 1 per cent.) will aid in this respect. If it is considered necessary to add tartaric acid to a wine, it should be done, as already explained, before and not after fermentation, or else a harsh wine will result which will set the teeth on edge. For that purpose the quantity of crystals of tartaric acid to be added to a given vat is distributed by hand over the grapes in the crusher, or else it is put in a bucket of must, dissolved, and added gradually to the vat in process of being filled with freshly crushed grapes.

The measurement of the acidity of the must is expeditiously done by means of a cheap apparatus called "acidimeter" but, on account of the small quantities of liquid operated on, any error in measurement is greatly increased when calculated to one vatting.

In wine analysis the acidity is usually expressed in terms of sulphuric acid. This is a conventional arrangement, but when dealing with musts it is preferable to express the acidity as tartaric acid. To calculate the acidity as tartaric acid, the figures expressing it as sulphuric acid must be multiplied by 1.53 (page 422).

The acidification of the vintage is so rarely necessary in Australia that it is not practised.

SPECIFIC GRAVITY, Equivalents of the Brix and Baumé Scales, and Alcoholic Strength after Fermentation.

Specific Gravity.	Baumé.	Brix, or per cent. of sugar in must.	Absolute alcohol per cent. by weight in wine.	Absolute alcohol per cent. by volume.	Percentage of proof spirit.
1.000	0.0	0.	...	...	...
002	...	.5	...	...	...
004	.5	1.	...	...	...
006	...	1.5	...	...	...
008	1.0	2.	...	...	...
010	...	2.5	...	...	...
012	...	3.	...	...	...
014	2.0	3.5	...	...	...
016	...	4.	...	...	...
018	...	4.5	...	...	...
020	...	5.	...	...	...
022	3.0	5.5	...	...	...
024	...	6.	...	...	...
026	...	6.5	...	...	...
028	4.0	7.	...	...	...
030	...	7.5	...	...	...
032	...	8.	...	...	...
034	...	8.5	...	...	...
036	5.0	9.	...	...	...
038	...	9.5	...	...	...
040	...	10.	4.5	...	10.
042	...	10.5	4.8	...	10.5
044	6.0	11.	5.1	...	11.1
046	...	11.5	5.4	...	11.9
048	...	12.	5.7	7.	12.5
050	7.0	12.5	6.0	7.48	13.1
053	...	13.	6.5	8.10	14.2
055	...	13.5	6.8	8.48	14.8
057	...	14.	7.2	8.96	15.7
059	8.0	14.5	7.5	9.33	16.4
061	...	15.	7.8	9.70	17.0
063	...	15.5	8.1	10.00	17.7
066	9.0	16.	8.6	10.66	18.8
068	...	16.5	8.9	11.00	19.4
070	...	17.	9.2	11.40	20.0
072	...	17.5	9.5	11.79	20.7
074	10.0	18.	9.8	12.10	21.3
076	...	18.5	10.1	12.50	21.9
078	...	19.	10.5	13.00	23.0
081	...	19.5	10.9	13.25	23.6
082	11.0	20.	11.2	13.60	24.3
085	...	20.5	11.5	13.95	24.9
088	...	21.	12.0	14.84	26.0
090	12.0	21.5	12.3	15.20	26.6
092	...	22.	12.6	15.44	27.3
094	...	22.5	12.9	15.90	27.9
097	...	23.	13.4	16.30	28.9
099	13.0	23.5	13.8	16.85	29.8

SPECIFIC GRAVITY, ETC.—*continued.*

Specific Gravity.	Baumé.	Brix, or per cent of sugar in must.	Absolute alcohol per cent. by weight in wine.	Absolute alcohol per cent. by volume.	Percentage of proof spirit.
101	...	24.	14.	17.26	30.2
103	...	24.5	14.3	17.47	31.0
106	...	25.	14.6	17.85	31.7
108	14.0	25.5	14.8	18.06	32.1
110	...	26.	15.2	18.60	32.6
113	...	26.5	15.4	18.80	33.3
115	15.0	27.	15.6	19.05	33.8
1.118	...	27.5	16.0	19.68	34.5
120	...	28.	...	...	...
123	...	28.5	...	...	...
125	16.0	29.	...	...	...
127	...	29.5	...	...	...
130	...	30.	...	...	...
132	...	30.5	...	...	...
134	17.0	31.	...	...	...
137	...	31.5	...	...	...
139	...	32.0	...	...	...
142	...	32.5	...	...	...
144	18.0	33.	...	...	...
147	...	33.5	...	...	...
149	...	34.	...	...	...
152	19.0	34.5	...	...	...
154	...	35.0	...	...	...
157	...	35.5	...	...	...
159	...	36.	...	...	...
162	20.0	36.5	...	...	...
164	...	37.	...	...	...
167	...	37.5	...	...	...
169	...	38.	...	...	...
172	21.0	38.	...	...	...
174	...	39.	...	...	...
177	...	39.5	...	...	...
179	22.0	40.	...	...	...
182	...	40.5	...	...	...
185	...	41.	...	...	...
187	...	41.5	...	...	...
190	23.0	42.	...	...	...
192	...	42.5	...	...	...
195	...	43.	...	...	...
198	...	43.5	...	...	...
200	24.0	44.	...	...	...

N.B.—Must having a specific gravity under 1,100, or 13deg. Baumé, will ferment completely and produce a dry wine, unless the temperature in the vat has been allowed to rise too high, in which case the fermentation may get “stuck,” although there may be more sugar unfermented in the wine.

Must, with a specific gravity ranging from 1,100 to 1,115 (13deg. to 15deg. Baumé), will have a greater difficulty to ferment dry, as the specific gravity

runs higher; and the fermentation may stop before all the sugar has been converted into alcohol, if adverse agencies set to work in the course of fermentation.

The best French wines, made from the choicest varieties of grapes, are produced from musts having a density ranging from 1,059 (8deg. B.), and 1,115 (15deg. B.). Thus, musts producing the Médoc wines measure, on an average, 1,066, or 9deg. B.; musts, from the Rhine, about the same; must, in the Champagne district, 1,074, or 10deg. B.; in Burgundy, 1,090, or 12deg. B.; and in the Roussillon district, in the South of France, 1,108, or 14deg. Baumé.

Musts, with a specific gravity higher than 1,116 (15deg. B.), yield either wine suitable for blending with a lighter one—they have the disadvantage of introducing with them an excess of unfermented sugar, which often produces troublesome secondary fermentations—or else they are only suited for producing liqueur wines.

### Proof Spirit

is an empirical more than a scientific way of expressing the alcoholic strength of a spirituous liquid, but it is so extensively used in trade that the following remarks will be useful.

It is defined by an Act of Geo. III. as weighing at 51° F. (10.5° C.) twelve-thirteenths of an equivalent volume of distilled water. This at 60° F. (15° C.) shows a specific gravity of .9198, and represents by weight 49.24 per cent. of absolute alcohol. This by Guy Lussac's tables shows 57 of absolute alcohol. *Absolute alcohol* is quite free from water, and has a sp. gr. of 0.793, and is 75.25 O.P. To reduce proof degrees to *pure alcohol* it is near enough in practice to multiply by 4 and divide by 7, and *vice versa* from degrees of alcohol to proof. Thus 75 O.P. = 175° proof

$$4 \quad 700$$

and  $175 \times \frac{4}{7} = 100$  Alcohol.

$$\frac{7}{7}$$

To bring an alcoholic solution indicating O.P. or U.P. degrees to proof the following formula may be used:—

$$\frac{100}{100 \pm n} = \frac{Q'}{x}$$

$n$  = degrees O.P. or U.P. indicated, which are hundredths of proof.

$Q$  = quantity of spirituous liquid of a given strength.

$x$  = quantity of proof spirit in the said spirit.

Ex.: 40 gallons at 30° O.P. or U.P. to be expressed as proof spirit.

$$\text{1st} \quad \frac{100}{100 + 30} = \frac{40}{x}; x = 52 \text{ Proof gallons}$$

$$\text{2nd} \quad \frac{100}{100 - 30} = \frac{40}{x}; x = 28 \text{ Proof gallons}$$

*Ratio between Absolute Alcohol and Proof Spirit.*

To express in terms of proof spirit a given percentage of absolute alcohol in volume, multiply that percentage by 1.7525, or 1 of absolute alcohol = 1.75 = .57 absolute. Thus:

100 vols. absolute alcohol = 175.25 proof spirit.

1 vol. absolute alcohol = 1.7525 proof spirit.

Ex.: A wine contains 13 per cent. absolute alcohol;  
find strength in proof spirit.

$$\frac{175.25}{100} = 1.75 \text{ Proof sp.} = 1 \text{ vol. absolute alcohol}$$

$$\frac{175.25}{100} \times 13^\circ = 22.78 \text{ Proof spirit}$$

Coversely:

A wine contains 25 per cent. of proof spirit; how much absolute alcohol?

$$1 : 1.75 :: x : 25 = 14.25 \text{ per cent.}$$

or:

$$\begin{array}{l} 175 \text{ Proof spirit} = 100 \text{ vols. absolute alcohol.} \\ 100 \text{ Proof spirit} = 100 + 100 \\ \hline \qquad \qquad \qquad 175 \end{array} = 57.02 \text{ absolute alcohol.}$$

$$1 \text{ Proof spirit} = \frac{57}{100}$$

$$25 \text{ Proof spirit} = \frac{57}{100} \times 25 = 14.25 \text{ absolute alcohol.}$$

*Formula for fortifying Wine.*

To find the number of liquid gallons of spirit required to raise the given strength of a wine to any required strength:—

Multiply the difference between the given alcoholic strength and the required strength by the number of gallons to be fortified.

Divide the product by the difference between the required strength and the strength of spirit to be used.

Ex.: Given spirit at 60° O.P., how much is required to raise the strength of 100 gallons of a wine at 24° O.P. to 32° O.P.?

$$\frac{(32 - 24) \times 100}{160 - 32} = \frac{800}{128} = 6.25 \text{ Liquid gallons.}$$

If required to raise to 35° O.P., 8.8 liquid gallons would be required. A wine containing 34 per cent. proof spirit is safe against lactic acid fermentation.

*Alcoholic and Sugar Contents of Sweet Wines.*

Distil the sweet wine to find the alcoholic strength, using for the purpose a given volume of the wine. Bring the distillate up to the original volume of the wine tested, bring it to 60° F., and dip the hydrometer and refer to special tables for strength of the wine. Special hydrometers, called "alcoholometers," are made giving on the stem spirit reading, and without bringing the distillate to 60° F. refer to the tables sold with the instrument, which gives the strength for any ordinary temperature shown by a thermometer which is used conjointly with the alcoholometer.

For the sugar contents of the wine use the residue of the distillation in the still after the alcohol has been driven out by boiling, or take any quantity of the wine, boil to drive out the alcohol, bring the liquid to the original quantity used by adding distilled or rain water, dip the densimeter, which will give the contents of sugar together with the small percentage of non-volatile extracts natural to the wine.

Pasteur's experiments show that during the process of a healthy fermentation 17 grammes of grape sugar per litre of must produce 1° in volume of alcohol, or, in other words, 1 kilo 700 grammes of sugar produces by fermentation 1° alcohol in 100 litres or 1 hecto-litre of must.

## WINE, PER TON OF GRAPES.

The amount of wine yielded by a ton of grapes varies according to a number of circumstances, chiefly the kind of grapes, the kind of season, the locality, the climatic conditions, and also the time of gathering.

Grapes, according to kinds, will yield more juice, and consequently more wine, at the beginning of vintage than in the middle or towards the end of the picking season when, although the sugar strength is greater, the quantity of juice is reduced. On the coastal and more humid districts the liquid contents is also, with us, greater than in the warmer and drier inland districts, and for that reason it is not an easy matter to give the quantity of must or of newly made wine one should get from any particular kind of grape.

If a broad average be taken, several of the grapes more extensively grown will yield, with us, as follows:—

Cabernet	...	...	...	...	100 to 115 gallons
Morastel	...	...	...	...	110 .. 120 ..
Shiraz	...	...	...	...	120 .. 135 ..
Mataro	...	...	...	...	130 .. 150 ..
Doradillo	...	...	...	...	140 .. 160 ..

In France an average of about 70 per cent. is obtained, whereas in Australia, which, on the whole, is warmer and drier,

the same grapes yield 60 to 65 per cent. of wine; or, in other words, 100lbs. of crushed grapes yield about six to six and a-half gallons of wine, or 135 to 145 gallons of new wine to the ton.

The average yield of wine per acre for Australia is about 200 gallons per acre of wine grapes.

#### SHOULD GRAPES BE STEMMED OR STALKED.

Experience with us, as well as wherever wine is made from the choicer varieties of grapes, distinctly gives an affirmative answer. A chemical examination of the stalk shows that there is little or nothing in it which enters into the composition of wine. The only soluble substances it possesses—viz., tannin, albuminoid substances, organic acid, and salts—already occur in abundance in the grape must. Wines fermented with husks and stalks added are harsher than wines fermented without stalks; they also often show an earthy taste, and are not so clean to the palate. These disadvantages are serious enough in themselves, but there are other reasons why wines—red wines are here inferred—should not be fermented on their stalks, such as the economy of space in fermenting, stalked grapes occupying one-third less space inside the vats; the greater similarity between wine running freely from the vats and press wine, which when stalks are present are invariably much harsher; another reason is that wine from stalked grapes mature quicker and can be marketed sooner than would otherwise be the case.

Stalking, moreover, is effected by a mechanical tearing and tossing about of the grape, which results in a thorough aeration of the must, an operation which ensures a more active and healthy fermentation, and reacts favourably on the quality of the wine.

In the manufacture of white wine the same objections disappear, as white wines are not fermented on either skins or stalks.

For the easier pressing of the sweet juice out of the glutinous pulp, however, the admixture of stalks are of great assistance, as they prevent the solidification of the soft pulp.

In that case, the stalking part of the machine should be thrown out of gear and the whole bunch, stalk and all, mangled between the rollers of the grape mill. If the type of machine does not permit of that, the pulp and the stalks should either be mixed together in the cage of the press, or else they should be superposed in alternate layers, as the stalks will prevent the solidification of the glutinous mass and keep it porous and open, thereby favouring the escape of the juice when the pressure is applied.

White wines fermented apart from skins and stalks are lighter in colour; it is true that the wine is at times slow in clearing, on account of a deficiency of tannin which the pips and the stalks failed to impart to it. By pressing the stalks with the pulp this deficiency is in some measure corrected.

## AERATION.

The operation of running the grapes through the stemmer and crusher, it has been noticed, results in a better aeration of the must, as the bunches of grapes are vigorously tossed about during that process, with the result that the skins burst, and, after passing through the rollers, the berries are reduced to a state of pulp.

Pasteur demonstrated that one of the main factors in the maturing of the wine is the oxygen, which is readily taken up by its constituents and by them held in a state of loose chemical combination, from which it is readily given up as required. A phenomenon of a similar nature occurs in the case of the grape juice; under the influence of warmth and the oxygen absorbed by the liquid, the process of maturation of the grape is consummated inside the vat, and the must is thereby enriched by the full amount of fermentable grape sugar it is capable of acquiring.

Although the must absorbs much air during the operation of crushing, it is often considered advisable to further aerate it prior to setting it to ferment.

The influence of aeration in quickening the starting of fermentation is now well understood by the wine makers of the old world, and various designs, as well as special appliances, are employed in carrying out that process, both in the making of red and of white wines.

Among the advantages which result from the aeration of the must, or mash of grapes, before it is turned into wine, the following may be mentioned:—

- (1.) The cooling down of hot must obtained from grapes picked during the hottest hours of the day.
- (2.) A greater regularity in the progress of fermentation.
- (3.) Its earlier completion, hence less exposure to the air, and therefore less risk of contamination by injurious microbes which float in the air.
- (4.) The quicker clearing of the young wine. Aeration or oxidation causing the precipitation into the lees of some of those rapidly-decomposing white-of-egg-like or albuminoid matters in the must, which afford a favourite food for dangerous microbes.

As an instance of this, I may just mention that in the Department of Meurthe, in the North-West of France, where the grapes contain much albuminoid matter, aeration is carried on systematically as one of the processes of wine-making. For this purpose the must is thoroughly stirred by means of shovels, till the air is well incorporated through its mass, and such wine, which is known as *vin de pelle* (shovel-made wine), by reason of its superior quality,



sells for 20 per cent. more money than wines made from similar must, but according to the ordinary methods of vinification. The cost of this very simple but laborious operation is reckoned at barely 1d. more per gallon. With the modern mechanical appliances, this cost is reduced, whilst the resulting advantages are decidedly important. Of late years a machine constructed on the principle of a cream-separator, and known as the æro-crushing grape mill, has been introduced, which effects this work with great thoroughness. Such a machine, I have no doubt, should prove a great success in hot countries, where the grapes mature very quickly, and more especially on rich alluvial land, the percentage of these nitrogenous matters increase very much, and it is of great importance that any of the surplus of it, beyond what is necessary for the use of the yeast fungi, should be removed. Some grapes are exceeding rich in these bodies, notably the riesling and the muscats.

Aeration is more especially beneficial to white wine. One of its actions on must is to bring about the precipitation of the colouring matter. A ready method of securing it is by means of a pump, through which a current of air is injected into the liquid. A rose is attached at the end of the delivery pipe. This is done for 10 to 12 minutes, but must not be overdone, so as not to impart to the wine a yellowish colour. With a little practice, the exact time when aeration should cease is soon known. If every five minutes a little must is run through some filter paper, the pumping is stopped directly the liquid ceases to show a rosy tint. A brownish-looking precipitate is collected on the filter. Subsidising is necessary after aeration. One disadvantage of aeration is that it promotes the trouble called *casse*, or causes the colour of the wine to "break" Two *casses* are known, the "brown" and the "blue." Sulphur fumes are used as a preventative or a colour restorer. Used as a preventive, it gives better results. Six grammes of sulphur per 100 gallons, nearly  $\frac{1}{4}$ oz., after aeration and before fermentation, six grammes when first drawing off, and six grammes when racking for the first time, will prove efficacious against this trouble. Potassium metabisulphite may be substituted for sulphur, and in that case double the quantity of that substance is used—two grammes of bisulphate of potash produce one gramme of sulphurous acid. If sulphur is used, it may be burned under a cask with one head removed and the fumes are sucked from the bung hole and pumped into the must.

#### VATTING

is the name given to that period during which the must is in contact with the husks. As a rule, short fermentations result in a more delicate wine, with good keeping qualities; long fermentations producing harsh wines, heavy in colour, and not so easy to keep.

Whenever possible the vatting of the grape pulp should be done by gravitation; time and labour is saved, and the work is done with greater cleanliness.

The filling of the vat should be done during the day, and not spread over two or three days.

It is immaterial whether only one or several kinds of grapes are mixed together in the vat, provided that they be all of one type and are meant for making one class of wine. Each sort is, however, generally fermented apart from the other, and the resulting wine is blended afterwards if required.

The vats should not be filled to more than four-fifths of their capacity, as much swelling of the mass occurs during fermentation, and if the rise of the liquid occurred during night time loss of wine would result. By keeping the level of the fermenting must below the edge of the vat, excess of air is to a great extent screened off by a layer of carbonic acid gas; which being about three times as heavy as air, covers the fermenting liquid and prevents oxidation and acetification of the cap or floating husks.

Questions are often asked: Should the fermentation be conducted in open or in closed vessels? Should the skins or caps be kept immersed or left to float during fermentation? In both cases, more especially in hot countries, both theory and practice strongly favour open vats and submerged heads. There takes place during fermentation a chemical reaction which results in the splitting up of grape sugar into alcohol and carbonic acid. This reaction, which is set up by living organisms or yeast, is accompanied by much evolutions of heat, and the richer the liquid is in sugar, the hotter the temperature, within limits, which we will consider presently, the greater that evolution of heat becomes.

Unless some means offer of dissipating that heat generated during fermentation, its accumulation might reach a point which would soon endanger the life of the active agent of fermentation. Fortunately, two natural outlets exist for the dissemination of that generated heat: 1st, radiation from the surface and through the sides of the fermenting vessels; 2nd, the free escape of the carbonic acid gas, which rises to the surface in warm bubbles which burst and allow it to escape.

Closed vats, such as are used in the Medoc and other districts where the must is lighter, the temperature cooler, and the wine-makers most conservative in their methods, would in hotter climates, where the grapes are richer in sugar, prove an element of danger, for the reason that the confined heated carbonic acid gas, prevented from escaping freely from the fermenting mass, tends to raise its temperature beyond the limits desirable.

The following method of handling the crushed grapes ready for fermentation into wine I have seen attended with the best results and commend to the attention of wine-growers:—

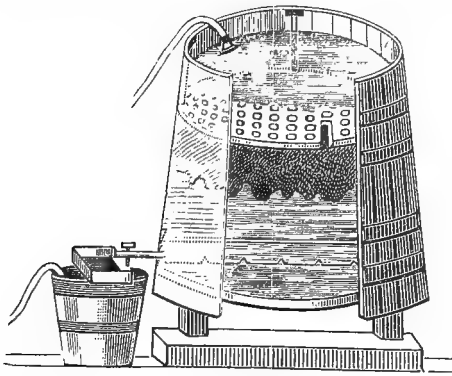

Grape Vat.

The grape pulp is conveyed in the ordinary way provided in each individual cellar, from the grape mill to the fermenting vat, which can well be an open one and should not be too deep, but rather shallow, and in this hot climate, not too capacious, viz., preferably from 500 to 700 gallons.

During this operation of filling up, a straight tap about one inch diameter, driven in the plug-hole at the base of the vat, is left open so that as fast as the liquid must and pulp fall from the grape crusher the liquid portion drains into tubs provided under the tap. Reference to the above illustration will show a simple and an effective method of allowing the liquid to drain through the solid pulp. It consists of an inverted gutter with a V-shape section, made of two lengths of six-inch boards, a little shorter than the diameter of the base of the vat. This gutter, with the edge uppermost, is made fast by driving a wedge between the end further from the tap and the side of the vat; it is notched at the bottom so as to let the liquid run freely.

When the vat is about half filled with freshly-crushed grapes, a light and movable false head or grating is made secure above them. The liquid must collected in the tubs is then restored to the vat, and allowed to rise some six to nine inches above the perforated false head.

Being left to itself, the fresh must undergoes in a short time a remarkable change. Originally clear, it soon shows signs of clouding up; small gas bubbles begin to form and ascend, and finally cause a decided foaming. The grape must ferments.

This stage can with advantage be quickened by adding a "starter" to the crushed grape, prior to covering it up with the false head. This consists in a few buckets of foaming and fermenting must from an adjoining vat. Under the combined influence of the congenial temperature of the fermenting house and of this freshly-crushed, well-aerated mass, the newly added ferments soon take hold of the contents of the vat, and within a few hours fermentation is in full swing.

Where cement vats are used the same method may be employed. By referring to the figure on page 412, an open down-pipe or a wooden box drain is seen placed into the fermenting mass; into this a syphon is placed and the liquid may be syphoned out and pumped back again over the top of the vat, spreading it over the head; it is thus cooled and aerated and helps to check a rise in the temperature to a degree above the danger point, viz., 92deg. F. or 33deg. C. The temperature most favourable for a healthy fermentation is about 86deg. F. or 30deg. C.

#### SEPARATING MUST FROM THE SKIN.

The above methods answer when red wine is concerned; white wine is made differently.

The mashed grapes are thrown into a vat provided with a drain at the bottom. The tap on the vat is left open and the liquid grape must runs freely into receiving tub. As it drains through the crushed mass it runs clear and it may be fermented straight away. Even red grapes, with the exception of a few coloured juice kinds, thus yield a must which can be turned into a white wine.

#### SULPHITING AND CLEARING OF FRESH-DRAWN MUST.

The liquid collected either straight from the vat or from the press having been pumped into a vat, may be allowed to settle for 24 hours to get rid of much of the solid matters in suspension. If desired it may be aerated, as previously explained, or it may be treated with sulphur fumes; the use of the one does not preclude that of the other treatment. Unless the liquid was subjected to the influence of sulphur fumes it would not rest and fermentation would soon set in.

One easy method of sulphiting this must consists in burning under a barrel with the head taken off 5 grammes (75 grains) of sulphur for every 22 gallons (25 grammes, or  $\frac{1}{2}$ oz., per 100 gallons) of must treated.

That inverted barrel is slightly raised by means of a wedge, to admit air sufficient for the combustion of sulphur. The suction hose of a pump is fastened to the bung-hole, and when the large vat is about one-third full of fresh white must, the pump is brought into play and sulphurous fumes injected by means of the delivery hose of the pump. This checks fermentation.

It is known that the sulphiting is being satisfactorily done when, whilst the pump is at work, there is no smell of sulphur fumes perceptible when standing close to the cask. Another simple contrivance for effecting this purpose is illustrated in Paul's Muteuse. The must to be treated enters at the top and falls on oblique alternate shelves coming in contact with ascending sulphurous acid fumes generated in a stove.

Eighteen to twenty-four hours after sulphiting, which, if well carried out, checks fermentation from setting in early, the clear must is drawn and transferred to the fermenting vats or casks, and the viscous product which has subsided during the period of rest of the must is sent to the still-house, where it ferments.

By this method most of the injurious microbes present in grape must are carried down in the sediment and removed from the clear liquid, in which remain a number of yeast germs, which are more resistant to the action of sulphur fumes, and soon take charge of the fermentation, which then proceeds slowly and evenly, and without further trouble.

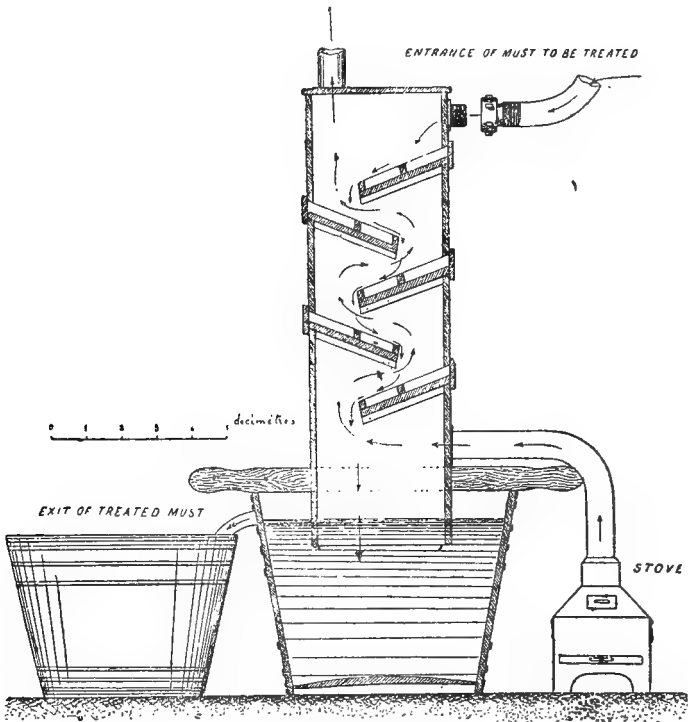

Paul's Muteuse (L. Roos).

Instead of sulphur fumes which are not easy to dose with any degree of exactness, a chemical salt, Potassium Metabisulphite, is frequently used. It holds sulphur dioxide in a loose state of combination and readily parts with it.

One ounce of sulphur by burning produces 2 oz. of sulphur dioxide or sulphurous acid.

Half an ounce of this gas will delay fermentation in 100 gallons of grape juice 10 to 12 hours.

One ounce Metabisulphite of Potassium yields  $\frac{1}{2}$ oz. of sulphurous acid fumes. When used for checking too rapid a fermentation and the invasion of injurious moulds and bacteria into a fermenting wine a fairly heavy dose is used, as a good deal of the sulphur fumes become non-effective and are driven out during the tumultuous fermentation.

To control and check rapid fermentation, 8oz. of Potassium Metabisulphite may be used per ton of grapes. Divide into four packets of 2oz. each. Dissolve in a bucket with hot water; mix the first dose with the bulk of the pulp or of juice. Take the temperature; when it rises fairly high add the second packet; then the third packet. The temperature is taken every few hours. The fermentation may be longer, but accidents will be averted. Even if sulphiting does not prevent hot fermentations it generally averts some of the worst consequences of hot fermentations by discouraging the growth of injurious moulds and of bacteria.

#### FERMENTATION.

Is the process of biological transformation of substances in solution in a liquid into products chemically different. This transformation is generally accompanied by movements similar to boiling (*L. fervere*, to boil). In the case of vinous or of alcoholic fermentation, there is production of bubbles of gas and also of alcohol and of other products.

The active agents of fermentation are micro-organisms which float inside the liquid which affords them food; they are capable of transforming considerable quantities of material into other products.

Although wine is the result of the fermentation of the juice of the grape, it is only when acted upon by microscopic living organisms which have received the name of "yeasts," that the transformation of the sweet juice of the fruit into wine is accomplished.

On every sweet fruit, nature has placed some kind of ferment capable of converting its juice into a fermented liquor. In grapes these ferments, known in France as "levures," in England as "yeast," are known to botanists all the world over—for yeast is a plant—by the name of *Saccharomyces*.

Thus, of the ferment of beer, known as *S. cerevisiae*, there are several sub-varieties, some of which, like the ferments of "low fermentation," are bred by the brewers of lager beer and maintained at a low temperature of 45 to 54deg. F. (7-12° C.), and others, the ferments of "high fermentation," are to be found in those breweries where the type is more that of Bass's beer or Guinness's stout.

These thrive best at temperatures ranging from 65 to 85deg. F. (18-30° C.).

They consist of a series of cells, more or less oval in shape, the long diameter of which is about .001 min. (1 metre = 1,000 min. which approximately equals 1 yard, so that 1 min. = 1/1000 yard).

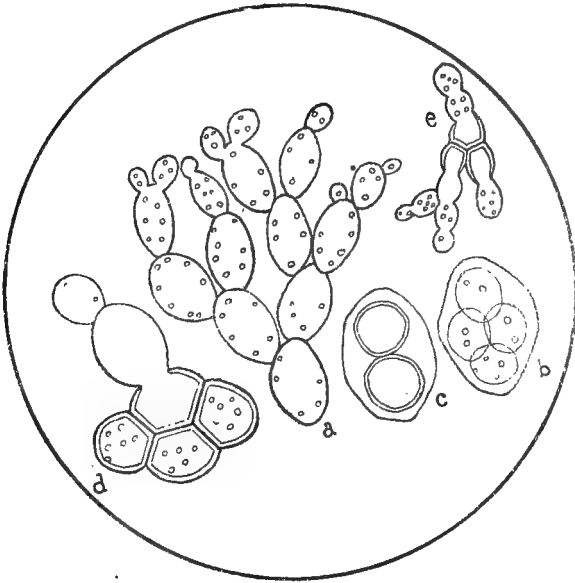

*Saccharomyces cerevisiae*, or yeast of beer (highly magnified).

Each cell is composed of a fragment of protoplasm, surrounded by an envelope of cellulose. These cells multiply very rapidly in several ways. 1st. By sprouting or budding; new cells showing like dots on the margin of older ones and growing gradually until they constitute fresh cells. 2nd. By fission, when the conditions are not so favourable. If a drop of fermenting beer is watched under the microscope, small granular bodies or nuclei are seen inside the yeast cell; by degrees this pinches in and splits up into two to four cells. Within these mother cells are the spores or their kernels, which are endowed with greater resisting power.

The ferments of wine proper, *S. ellipsoideus*, also comprise several families. Their *optima* temperature, i.e., that at which they are in the full possession of all their energy, ranges also from 70 to 90deg. F. (22-32° C.) Below that temperature they are sluggish and languid, above the higher one they are, after having passed through a feverish period, left sickly and weakened. They are elliptical or rather lenticular in shape, and reproduce by sprouting.

When young and active they are seen, under the microscope, to be full of refractive liquid; when old or living in an unfavourable liquid, they are shrivelled and more or less opaque.

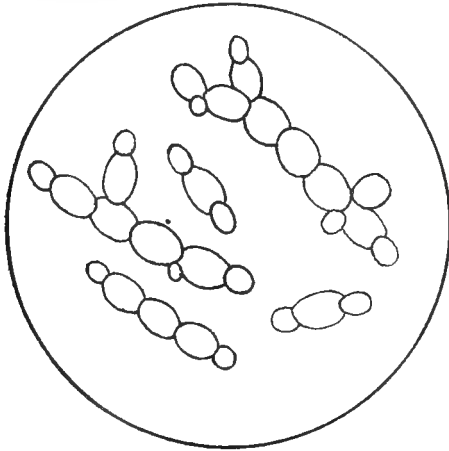

*Saccharomyces ellipsoideus*, yeast of wine (highly magnified.)

Although the principal agent of vinous fermentation, the elliptical yeast is not exclusively so. When the conditions which

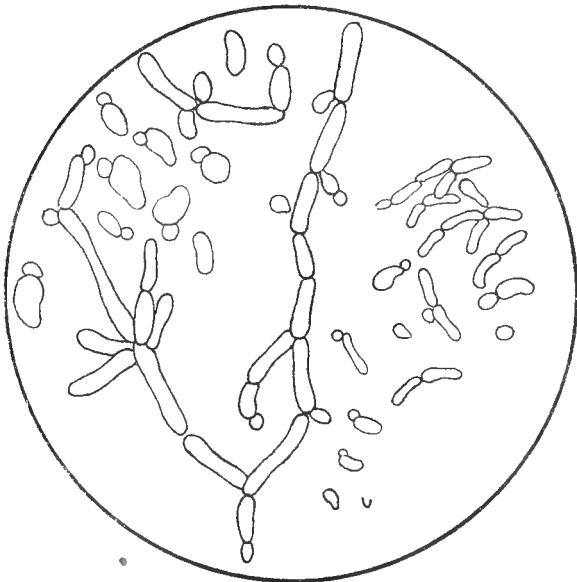

*Saccharomyces pastorianus*, ferment of secondary fermentation of wine (greatly magnified).



surround it are favourable, viz., a slightly acid saccharine solution and a temperature of 28 to 32deg. C. (83-90° F.), it has a great capacity for work and can live in an alcoholic liquid containing up to 16 per cent. (by volume) of alcohol (28 per cent. of proof spirit), but in unsterilised must it rarely starts working, and generally follows the lead of apiculate yeast.

There is also to be found in wine the *S. pastorianus*, more injurious than useful to wine, and until the fermenting wine reaches 75° F. (24° C.) there is always the danger of the elliptical yeast not being able to overcome that particular wild yeast.

In the spring when sweetish wines begin to work, it is this yeast which is found mostly in the wine; it likes a cool temperature, but the quality of the spirit it turns out cannot be compared with that elaborated by the elliptical yeast.

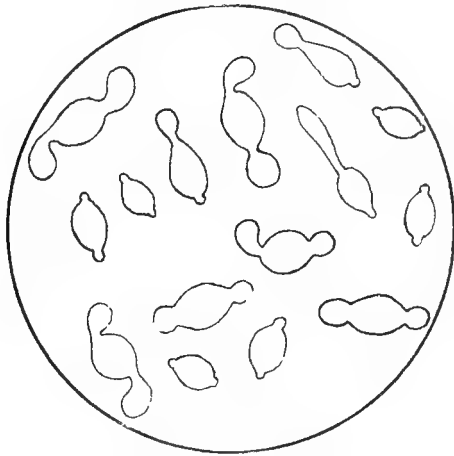

*S. or Carpozyma apiculatum.*

There are other kinds of yeast, such as *S. apiculatus* or *Carpozyma apiculatum*; which is neither good nor bad. This particular one is met with on tart and unripe fruit; it has no great capacity for work. Although it generally starts fermentation it is of a very tender nature; and the apiculate yeast gives way to the elliptical yeast when there is 3 to 4 per cent. of alcohol in the wine, or when the temperature rises above 75deg. F. (24deg. C.) It consists of pear-shaped cells. In injured grapes, delayed in crushing *S. apiculatus* multiply very rapidly. In fact the first part of the spontaneous fermentation of grapes is generally due to this particular yeast, and unless measures are taken to prevent it, *i.e.*, sulphiting, using 8 to 10 ozs. per ton of potassium metabisulphite, much of the persistent cloudiness and the delay in the finish of fer-

mentation, even of otherwise good wine, is due to this cause. At the beginning of vintage and before the crusher, vats, and other surfaces have had time to get inoculated and to breed true wine yeast, the apiculatus yeast predominates. A spontaneous fermentation is therefore a defective method, and the use of a healthy "starter" is desirable.

Amongst the other ferments which can be found in greater or in lesser quantity floating in new wine, the quality of which they tend to depreciate, are two kinds of micro-organisms, one the *Mycoderma vini*, or "wine flowers," which, feeding on alcohol, robs the wine of its strength, and the second and more dangerous *Mycoderma aceti*, which is the bacterium of vinegar. Both of these thrive at a fairly high temperature ranging from 80 to 100 deg.

Besides these, again, there are the bacteria of lactic or of man-  
nitic fermentation, which are excited into life when the temperature in the vat or in the wine reaches 100deg. F. and over. There are also pseudo yeasts (*torulae*) and moulds, which not only waste sugar in the must and thus lower the strength of wine, but, what is much more serious, leave in the wine products they have eliminated which greatly lower its quality. Sulphiting of the must checks these robber organisms.

#### STARTING FERMENTATION.

Now that we are acquainted with alcoholic ferments and the conditions which are favourable or injurious to them, it will be readily understood that it is an advantage to start the fermentation as soon as ever the grapes are crushed and vatted, as the less the wine is exposed to the air the better are its chances of escaping contamination by the injurious bacteria of diseases which are always lurking in the cellar a chance to invade the wine and taint it. For that reason it is a good practice to start, a few days before vintage proper, a small fermentation under the most favourable conditions possible. For that purpose some sound and ripe grapes are picked whilst cool—in the morning—crushed, and set fermenting in a clean tub, in which a temperature ranging between 75° and 90° is carefully maintained.

This first fermentation will take longer to start than will otherwise be the case, as the appliances for wine making have not then been leavened, and the spores or germs of the yeast, which during vintage float about in abundance in the atmosphere of the cellar, are still scarce at this early stage of wine making.

When the fermentation has well set in, vintage is begun, and as the first vat is being filled a bucketful or two of that controlled ferment is thrown into it, with the result that a fermentation of the right sort speedily sets in.

The subsequent vattings are also leavened from those already in full fermentation, and thus the process is continued all through the vintage. This must be done at the right moment, as reference to the paragraphs dealing with the various kinds of ferments show that at the start the "apiculate" yeasts predominate, and at the end the *Mycoderma vini*, or "flower of wine," and the bacteria of acetic acid and of lactic fermentations, and also other undesirable micro-organisms are not uncommon. During the height of the fermentation, on the other hand, the "elliptical" yeast, or true wine yeast, has a good hold of the fermenting mass, and is then in a healthy and thriving condition.

In the course of his researches on beer, Pasteur demonstrated that several kinds of fermentation cannot proceed simultaneously and with equal intensity in a suitable liquid, and that the most energetic always masters and overpowers the others. The point to bear in mind is, therefore, to surround the particular kind of fermentation one strives to achieve with the conditions most favourable to its proper completion.

#### INFLUENCE OF TEMPERATURE DURING FERMENTATION.

Fermentation is the result of combustion. That combustion, as we have seen, is initiated whenever the yeast fungi have access to the sweet juice of the grape.

According to the researches of scientists, and in the first instance to Berthelot, 180 grammes of grape sugar, in being transformed into alcohol and carbonic acid gas, generate 71 calories, or enough heat to raise the temperature of a must containing 20 per cent. sugar and fermenting completely to 128° F., provided all the heat were accumulated in the fermenting vessel without loss.

This fact, demonstrated by theory, does not, however, occur in practice. Several sources of leakage tend to reduce that temperature, such as the radiation of heat through the staves or sides of the vat, the evaporation which takes place from the surface of the liquid, the bursting on the surface of the hot bubbles of the carbonic acid gas, which escapes through the air. Were it not for these sources of diffusion of generated heat, the yeast would soon be paralysed or killed, and the vat would get "stuck."

What that amount of heat is, at any given moment, within the mass in fermentation, can thus be expressed in the terms of a mathematical equation:—

The temperature of the fermenting mass is equal to that of the grapes at the time of crushing, plus that due to the heat evolved during the fermentation, less that lost by radiation and evaporation.

It is a matter of common observation that, unless checked, the temperature of a 600 or 700-gallon vat in Australia rises from 20° to 25° F. during fermentation. In other words, grapes crushed at

65° F. will rise in the vat, if the temperature be unchecked, to 80° or 85° F., whereas the same grapes vatted at a temperature of 75° F. will rise to about 95° or 100° F. As that temperature is decidedly injurious to the yeast of wine fermentation (*Saccharomyces ellipsoideus*), and on the other hand is favourable to bacterial life, or the life of those microbes which are the cause of disease in wine, it is obvious that, where no artificial means are at hand to control the excess of temperature, the grapes should be vatted only when cool.

It is therefore essential, whilst the grapes are fermenting, to ascertain, by means of frequent testings with the thermometer, what the temperature is inside the vat.

The elliptic yeast does its best work between the temperatures of 75° and 90° F. Below 75° the *S. pastorianus* or the *S. apiculatus*, which, at best, are but very poor kinds of ferments, thrive best; above 95° the ferments of acetic acid and of lactic acid play an active part, the conversion of sugar into alcohol ceases through the death of the yeast of wine fermentation, and the vat gets "stuck," with a proportion of unfermented grape sugar still left in it. During the course of a sickly fermentation, not only does the work done by sickly yeast plants fall short, both as regards quality and quantity, compared with what healthy yeast plants would do, but the same circumstances which have brought about that unsatisfactory state of things, *i.e.*, excess of heat, being favourable to bacterial life, it follows that the wine suffers in bouquet and aroma as well as in delicacy and purity. Besides, it becomes tainted by the deleterious products of undesirable and injurious bacteria, turning fiery and heady, and suffering greatly in character.

These injurious bacteria, feeding on what sugar is left unfermented, and also on the spirit or on the tartar of the wine, cause lactic or mannitic, acetic, tartaric, and butyric fermentations, which form products giving sweet-sour or milk-sour acid and mousy tastes, all defects aggravated by keeping, causing the wine to become flat, turbid, and difficult to clear.

#### REVIVAL OF FERMENTATION.

It some times happens that, in spite of all care and precaution, some vats get "stuck" before fermentation is completed. In such cases the remedy must be applied at once, and the wine-maker has the choice between several means of attaining that end.

One of the simplest is to draw the wine from the hot vat and fill smaller casks or vessels in which it will soon cool, with the result that the ferments will revive and show a tendency to accomplish their work. When this is noticed, the wine is restored to the vat, and a small addition of must in full fermentation added at the same time will soon help to restore matters.

The surest way of restoring fermentation in a "stuck" vat, or of preventing the temperature rising too high, is, however, to use a refrigerator or wine-cooler.

Full-bodied wine of high gravity may remain sweetish owing to exhaustion of yeast-food, which consists of oxygen, nitrogen, phosphoric acid, and potash. Of these, potash is present in ample quantities in the shape of cream of tartar. Phosphoric acid appears to be seldom deficient. Oxygen is easily supplied by aeration. Nitrogen in a form acceptable to the yeast plant is not always abundant enough. "Ammonia" is the form most readily absorbed by yeast, while "nitrates" appear to be useless. A yeast stimulant in the shape of ammonia salts may be useful at the close of a sluggish fermentation of such high gravity, full-bodied wines, the dose not to exceed 1oz. per 100 gallons of ammonium phosphate. If used in excess, it acts as food for bacteria as well as for yeast. Of ammonium phosphate there are two forms, viz., the mono-ammonia or acid phosphate, and the bi-ammonia or crystallised form. The first is preferable.

"Sweetish wine" from "stuck" vats is very dangerous to hold, as secondary fermentation sets in when the summer comes round. If not fortified at once, and it is desired to make it ferment out, good, healthy "levure" or yeast should be added, and in addition a little phosphate of ammonia, if procurable, of the dose indicated.

REFRIGERATORS, also called "attemperators," are mechanical devices for the purpose of cooling liquids, whether it be milk, as in a dairy, mash in a brewery, or must in a winery.

Several types are in use for that purpose, those which have met with greater favour being:—

*Metal spiral coils*, plunged in the fermenting must, and through which cold water is passed, have hitherto been much used in breweries as well as wineries. It consists of a horizontal circular coil to suit the shape of the vat, and made of tinned copper pipes one-sixteenth of an inch thick and one inch to one and a-quarter inch outside diameter, with supporting stays and suspending rods, by which it may be hung in the vat at any desired depth. The pipes are fitted with unions for connecting india-rubber hose for the supply of cooling water. When required to be removed, after fermentation, for cleaning purposes, it is readily hoisted by pulley blocks out of the vat. The pipes are set at a distance of about four inches apart, so as to allow of rapid and thorough cleaning.

Amongst other advantages, this attemperator is easy to construct, fairly cheap, and can be fitted up anywhere, being simply hung on a beam over the top of any vat. It is, by means of the pulley blocks and a counterpoise hitched on at the other end of the chain, set at any depth in the fermenting wine. A good depth, I

have found, is about six inches below the surface, as it is well known that fermentation, and hence development of heat, is more active at the top of a vat than at the bottom. The liquid on being cooled has, besides, a tendency to sink, and thus maintains amongst the lower layers of the fermenting must a moderate degree of temperature.

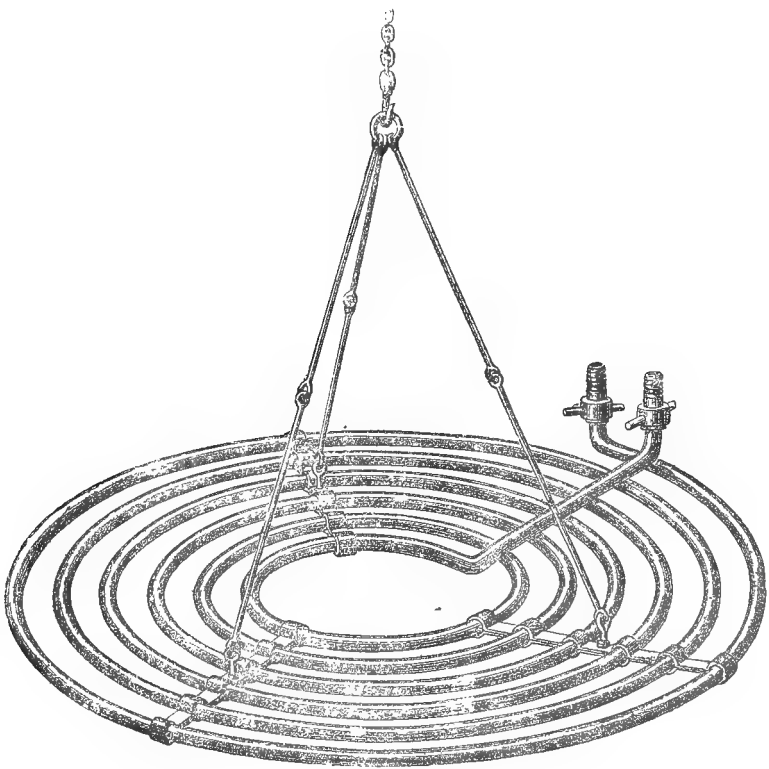

Tubular Attemperator.

In order to ensure an even penetration of the cooler temperature through the mass of the fermenting grapes, it is advisable to draw the liquid into a tub from the bottom of the vat and pump it back on the top, spreading it over the surface by means of a rose attachment.

For the purpose of working the attemperator, an abundant supply of cool water is necessary, and this can be pumped to a tank placed at a higher level than the attemperator itself from a well,

an underground tank, or even a cool stream. By means of a tap fitted on the supplying overhead tank the flow of the cooling water can be regulated so as to maintain the suitable degree of temperature in the vat.

This metallic spiral coil is only used in reducing the temperature in white wine vats, where the juice has been pressed from the skins; or in red wine vats provided with a false head for the purpose of submerging the cap.

The consumption of water, which varies with the degree of temperature of the must, that of the water itself, and the volume of must to be cooled with this apparatus, amounts to about an equivalent volume of wine to be cooled. Under unfavourable conditions this amount would be greatly exceeded.

*Muntz and Rousseaux tubular refrigerator.*—This cooling apparatus, which is constructed by the well-known firm of still manufacturers, Deroy fils ainé, of Paris, is, as it stands, one of the most improved wine-coolers constructed. It has been used with much success in the large wineries of Algeria and the south of France; but its disadvantage, from the Australian wine-grower's point of view, is its cost.

In the matter of wine refrigeration several factors influence the cost of the operations, viz., the cost of labour for pumping the wine and the water, the interest, and wear and tear of the apparatus. While the first item does not fluctuate very much, the second decreases as the volume of wine handled increases, and an apparatus, by means of which large volumes of wine could be treated at a nominal cost in a large winery, would prove a burden where smaller vintages are handled.

*Refrigeration by Ice.*—The use of attemperators or heat coolers have, under many hot climates, been used with most satisfactory results. Several designs have been contrived for that purpose, but they all entail a high initial cost, as well also as the necessity for a large supply of cool water, which has, in the first instance, to be secured and subsequently has to be pumped up before it can be utilised.

Where ice can be procured readily and at a reasonable cost, it affords a convenient means of regulating the temperature inside the fermenting vats. Where supplies are uncertain a quantity may be stored in a suitably constructed ice-chest, large enough for current requirements.

*Wine-making and Temperature control.*—The following fermenting chart illustrates the progress of fermentation under circumstances which I shall briefly explain. It illustrates graphically the progress of wine-making experiments I made during the vintage 1900 with ice as the temperature controlling agent:—

In order to further assist the yeast germs, the grape must, subjected to the cooling effect of the ice, receive an addition of 2ozs. to 3ozs. of tartaric acid for very 100 gallons. No. 1 diagram

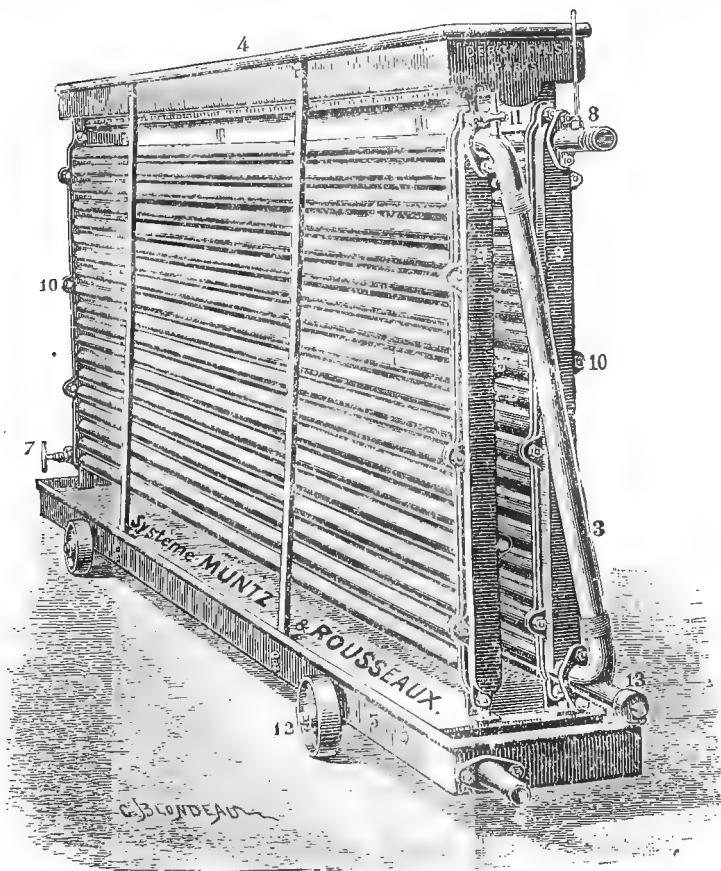

Muntz and Rousseaux tubular refrigerator.

illustrates the course of fermentation in a vatting of Malbec previous to the date when ice was used at all. Such defective fermentations are more the rule than the exception at many of our vineyards. The temperature in three days rose up to 97 degrees, a degree of heat which is prejudicial to a healthy fermentation. Concurrently with this rapid rise of the temperature, the attenuation of the must, or, in other words, the conversion of the grape sugar into alcohol, was speedily completed, although the must originally contained as much as 23.5 per cent. of sugar. It was sheer luck that



fermentation was completed without the vat getting "stuck" before all the sugar had been converted into alcohol. Such wine, although keeping sound, must have been robbed of much of its delicacy and of those wine ethers which produce the much-prized "bouquet."

# Fermentation Chart

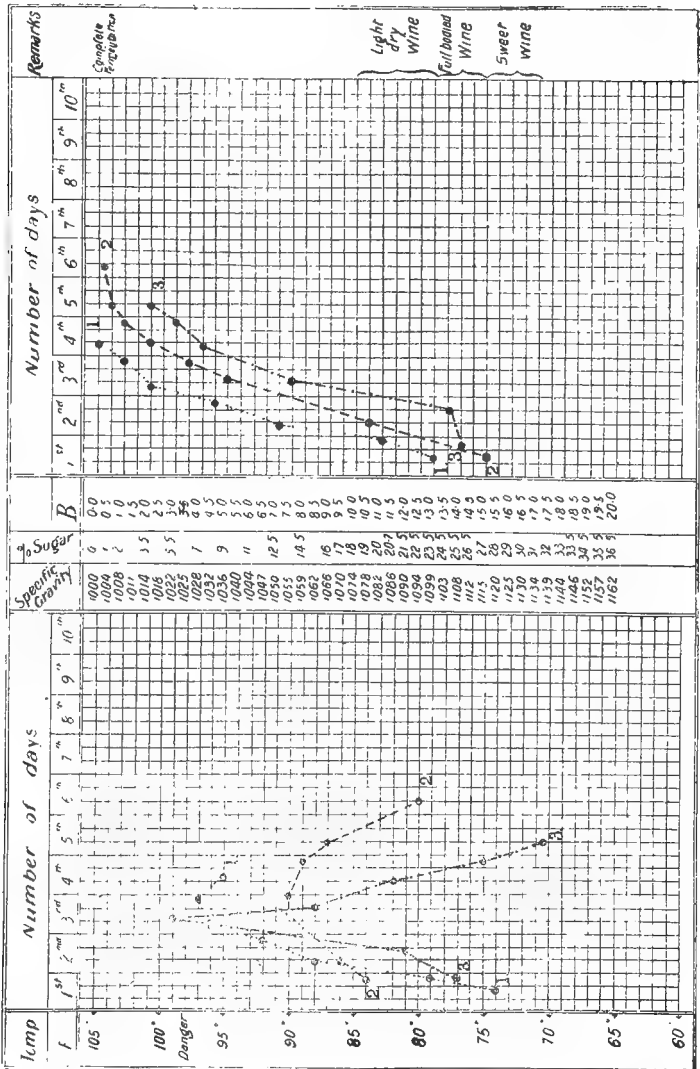

Because of the high elevation of temperature the strength of the resulting wine also suffered, a notable quantity of alcohol

having been carried away mechanically in the gases produced during fermentation.

No. 3 represents a fermentation of two tons five cwt. of Shiraz grapes. The timely use of ice here averted a disastrous fermentation. In two and a-half days the temperature jumped from 77deg. F. to 99deg. F., when 85lbs. of ice were placed in the coolers on the 17th of February in the morning, and the temperature was in a few hours brought down to 88deg. F. As explained on page 447, the optimum, or the most suitable degree of temperature for the yeast germs of vinous fermentation, ranges between 80deg. to 90deg. F. Below 80deg. fermentation is sluggish, and the yeast germs work slowly; above 90deg. F. fermentation becomes for a time tumultuous, until as the heat increases and gets nearer 100deg., when the yeast germs by degrees become paralysed and soon die, unless prompt relief is brought to them and the degree of heat reduced. When that higher temperature is reached, latent germs of diseases, such as the mannitic ferment, which produces *sour-sweet* wine, as well as other germs of maladies of wine, take possession of the fermenting mass, and in a short period spoil the wine.

In the instance under review the dangerous zone of temperature was soon reached and as quickly reduced, and although the fermenting mass was only subjected for a very few hours to a temperature ranging over 95 deg., the evil effect soon became apparent, and had not ice been timely applied, over 300 gallons of wine would have been irremediably lost. On the fifth day, the new wine was drawn into clean, cool casks, and still contained as much as 3.5 per cent. of grape sugar. Owing to the timely application of the ice, fermentation shortly afterwards started again, and the wine is now dry and sound.

No. 2 chart illustrates a healthy fermentation, and with proper care, the resulting wine should exhibit all the qualities which are prized in good wines.

The grapes are the choicest sorts used in wine-making, and are such as produce the celebrated Medoc and Hermitage wines of France. They were picked before they became over-ripe. A small quantity of tartaric acid was added to the must to further help the yeast plants in converting the grape sugar in the must into wholesome alcohol in the wine.

The fermentation lasted six days, and the temperature was maintained below 90 degrees F. The cap, made of skins and seeds, was kept submerged in the vat by means of a false head, and was not, as is often done, plunged three or four times a day into the liquid below. The result was a wine completely fermented; that is to say, a wine which does not contain any appreciable amount of grape sugar left. It was, moreover, lighter in colour than wines

fermented at a high temperature, and which had a floating cap repeatedly pushed down into it. It was not so harsh to the palate, and did not contain any excessive proportion of extracted matters. It cleared in the cask, and looked less turbid and more forward than wine from other vattings fermented at a higher temperature and without the cooling assistance of ice.

The ice used cost 5s. the 2cwt. block; with railway freight added, it cost about 3s. a cwt. The amount of ice used varied from 50lbs. to 85lbs. per vating of 200 to 350 gallons of must in fermentation. The ice was sawn into blocks which would fit into empty kerosene tins. The tins were provided with a wire handle, for convenience of handling, and weighted with bricks on top of the ice, so that they sink to two-thirds of their height into the fermenting mass, and rest over the perforated false head which keeps the cap down.

The ice melted more or less quickly, according to the degree of heat in the must, and as the upper layer of the liquid in the vat cooled, the hotter layer underneath was run into a tub by opening the cock at the bottom of the vat, and pumped and spread over the top of the fermenting liquid. This equalises the temperature all through the mass, and allows fermentation to proceed without hindrance.

WHEN TO COMMENCE COOLING is a question of great moment. The fermenting must should never be allowed to reach 100deg. F., as in that case the yeast suffers such harm that it does not always recover, and, in spite of all the maker's efforts, the wine may become permanently injured. If in a small vat, the heat is not likely to rise to danger point, but in a large vat it is advisable, if the must is still rich in sugar, to commence cooling when the thermometer marks 31deg. to 32deg. C., *i.e.*, 88deg. to 90deg. F., below that it would be waste of energy, and above it might prove sailing rather closely to danger point. The wine is left with a proportion of alterable substances and suffers a diminution in the alcohol and also the glycerine, both of which are necessary preservative substances.

## CONVERSION OF THERMOMETER SCALES.

The following diagram and formulæ show at a glance or enables one to connect the reading of any degree of temperature in the three scales used into any one or other of these scales. The wine maker is often embarrassed when reading reports on wine making to translate degree Centigrade into the more familiar Fahrenheit scale or *vice versa*.

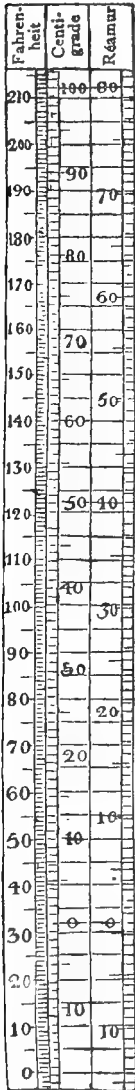

Conversion of  
Thermometer  
Scales.

$$32\text{deg. F.} = 0\text{deg. C.}$$

$$212\text{deg. F.} = 100\text{deg. C.}$$

To convert F. into C. degrees:—

$$\frac{F - 32}{9} \times 5 = C.$$

To convert C. into F. degrees:—

$$\frac{C \times 9}{5} + 32 = F.$$

WHEN TO DRAW THE WINE.—The initial fermentation when vintage begins is generally more protracted than the subsequent ones, for reasons that have already been referred to, the appliances for wine making having not yet been enlivened by the yeast of wine fermentation. After this first fermentation, however, under conditions prevailing at vintage time in the Australian climate, the march of fermentation is greatly accelerated, and in about three to six days the wine is fit to draw off the vat.

Sometimes fermentation runs wildly for two or three days and then stops short. In that case there is often sugar left unfermented in the must, and the cause as well as the remedy have been indicated in this chapter. After three or four days, under favourable conditions, the wine is pretty well ready to draw off; this is indicated by the saccharometer, which sinks to zero or thereabouts; better guides still are the taste and the eye. The wine should be fairly dry to the taste, *i.e.*, should have lost most or all its sugar. It should be somewhat rough to the tongue, indicating that it has extracted from the pips, as well as from the skins, a sufficient amount of tannin to ensure its sounder keeping and its

easier clearing. To the eye it should, if a red wine, be of a dark ruby or of a somewhat deep colour. If a white wine, it should have as little colour as possible beyond that which may be imparted to it by the *debris* of yeast cells and other impurities, which, after settling to the bottom of the cask, will soon leave it clear and transparent above.

#### LIQUOROUS WINES.

The methods already touched upon apply to white wines and to red wines which are fermented dry, *i.e.*, in which all the sugar is allowed to be transformed into spirit and carbonic acid.

Liquorous wines, of which Port wine, Madeira, Sauterne, and Sweet Muscats are types well known in commerce, are made somewhat differently. Some of their natural sugar is preserved in the wine, and fermentation is checked before it is complete.

To effect this, several methods are used. One of the most common is to allow the grapes to hang on the vines until they are dead ripe. The higher the state of maturity of grapes, the richer they are in sugar, whilst the acidity is neutralised by the migration of alkaline sap from the wood and leaves into the fruit. Also ethers are formed, which impart to the various sorts of grapes an aroma peculiar to themselves. This explains why sweet wines made from grapes which have been allowed to become dead ripe have more individual character than sweet wines made from the same grapes at an earlier period of maturity. In some localities, *viz.*, Tokay and Sauterne, which produce the most delicate sweet wines, the berries are allowed to even partially rot. A fungus known as gray mould, *Botrytis cinerea*, develops on the skin of the berries, and so modifies the juice as to give it a very delicate flavour. As a saprophyte it attacks the skin of the grape, facilitating evaporation of water and a resulting concentration of the juice. It then penetrates the pulp and feeds on both sugar and acid, principally the latter. No mouldy flavour is produced. It is known as the "noble mould" in the Sauterne district of France.

Whether white or red sweet wine is made, it is allowed to ferment for 24 hours in a large vat, and is then run out into well sulphured smaller casks, and the skins are pressed. As much sugar is still left in these, they are either put into another red wine vat to ferment, or a little water is added, and the resulting fermented mash is distilled. In the smaller casks, if necessary, a sufficient quantity of well rectified spirit of wine is added, to raise the alcoholic strength of the wine to 15 or 16 per cent. of absolute alcohol by weight, which is equivalent to 18 to 20 by volume, or to 32 to 34 proof spirit. It is better not to add this spirit all at once, but to bring the wine up to its full strength when the saccharometer

marks, according to the lesser or greater degree of sweetness it is desired to give to the wine, 2deg. to 4deg. Baumé, which would leave in the wine  $3\frac{1}{2}$  to 7 per cent. of unfermented sugar.

The formula for fortifying wine is given on page 433.

#### REARING OF YOUNG WINES.

After three to five days the fermenting wine, having been drawn from over the skins, is pumped into another receiver vat or cask to complete its fermentation.

A crackling sound, caused by a slow fermentation, keeps on for some little time, and as carbonic acid gas is given off, the casks should not be plugged tightly, lest they should burst. A good plan is to place over the bung-hole a small flat sand-bag, a few inches square, which, while not interfering with the escaping of the gas, keeps dust, germs, and the troublesome minute fermentation flies dropping into the cask.

To the same effect, specially constructed bungs are sometimes used.

The carbonic acid gas under tension from inside the cask forces its way out through the perforated plug which fits tightly into the bung-hole, and, overcoming the pressure of small layers of water, into which an inverted glass bell stands, escapes outside, whereas

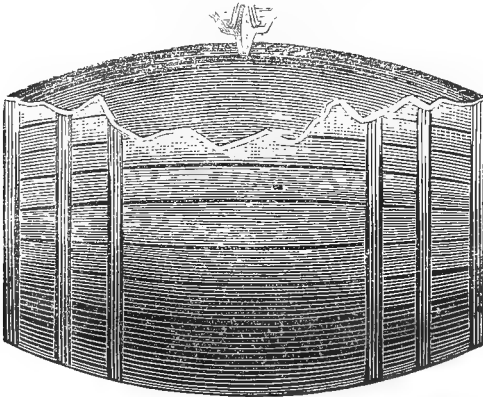

Showing Hydraulic Plug for wine casks.

the external air and all the impurities it carries in suspension, cannot get access to the wine in the cask.

Such plugs, although useful, are not indispensable to the safe keeping of well fermented young wines.

After a rest of two or three weeks it loses its turbid look and casts the dead yeast cells and other impurities which collect as lees

at the bottom of the receiver. It should then receive the first racking, and it is drawn from over these lees into clean casks in which sulphur fumes have been generated by burning a piece of sulphur tape.

The wine must be made to absorb the sulphur, either by spreading it by means of a rose or by pumping the sulphur fumes into it.

A few days after this racking the wine clears readily, and it is left for two or three months in well-filled and closed casks.

The filling of what is called the "ullage" should be done at least every fortnight, preferably every week, so as to absolutely exclude the air from the cask. Neglect of this precaution will cause the wine to become tainted with the moulds of flowers of wine and of acetic acid.

Towards the end of winter the young wine is again racked (2nd racking) in a similar way.

Again, a 3rd racking as spring comes round.

Racking is best done when the weather is clear and the barometer high, which with us in Western Australia generally occurs when the cool breezes are from the South-West.

If the white wine does not clear readily after the first racking,  $\frac{1}{2}$  to  $\frac{3}{4}$  oz. of tannin per 100 gallons are added; if it still remains cloudy and turbid a light fining with 6 to 8 grammes of isinglass, or some other good fining, per 100 gallons will clear it.

A 4th racking should take place before the subsequent vintage. At that time this young wine will have lost most of the carbonic acid it held in solution; it will be bright and clear and will rid itself of the harsh and raw taste of new wine.

After keeping for another year or two in clean casks, kept well filled and racked twice the second year, and once the third year, it will be ready for bottling after a fining or filtering or both, if necessary.

#### HOW TO RACK WINE.

This operation, which has for its object the removal of the clearer wine from over its sediment at the bottom of the cask and its transference to clean casks provided for its reception, is accomplished in a variety of ways, governed by local practice and by the nature of the appliances at hand.

The more generally used methods are:—

- (1.) The drawing of the wine direct from one cask to another by means of a hose or syphon.
- (2.) The transferring from one cask to another by means of pails or buckets.
- (3.) The drawing by means of a pump.

The first of these methods is largely practised in the Bordeaux district and in Burgundy, and answers very well for transferring the more delicate wines quickly from one hogshead to another without exposing them too much to the action of the air. It must be remembered that these hogsheads are piled up in two or three tiers one above the other. A hose connects the tap-hole of one hogshead to the other, and the wine from the full cask passes on to the empty one, if they are at the same height, till the level in each hogshead balances. By means of a pump fixed to the bung-hole of the first hogshead air is then forced into the cask, and extra pressure causing the wine to rise into the second cask until the contents of one have been transferred to the other. When the hogsheads of the second tier are decanted into the hogsheads of a lower one no air-pump is required, and the wine flows down by gravitation. The whistling sound of air getting into the hose tells that one of the hogsheads is almost empty; the hose is then disconnected, the cask gently tilted, and what clear wine remains in it is collected into a wooden pail, frequent samples being taken in a glass to show exactly the moment the slightest cloudiness is detected, when the racking must be stopped.

The second method of transferring from one cask to another by means of pails and other small vessels is still much used in some districts and notably at Mâcon, in France, and in small private cellars. This method, however, is not advisable, except for young and full-bodied and heavy wines, as it favours too much exposure to air.

The method of racking by means of a pump is much preferable, being the more rapid and involving the employment of less hand labour. It is much used, especially in the more modern and best equipped cellars of the South of France, where wine is generally, like in Australia, stored in large-sized casks.

When pumping new wine it is advisable to first draw it into a tub, whence it is pumped wherever required. By this means the wine becomes aerated and receives the ripening and mellowing action of the air.

Various methods are employed to effect the racking, but it is essential that pipes, hose, and pumps should be kept thoroughly clean and sweet by running water through them after they have been used. The suction hose should be steel-ribbed to prevent it from collapsing under the force of the suction. As to pumps, some very good models are now in use, the best being made of gun metal or of copper, and although they cost a little more in the first instance, they last much longer, and are not susceptible of being attacked by the acids in the wine.

A syphon is also much used in the process of decanting clear wine from one cask into another. A little practice will make anyone skilful in using it. One essential is, that the receiving vessel



should be on a lower level than the filled vessel in order to get the syphon to work at all, and this, it is found, is not in every case possible.

After a blend between two or more wines has been made, it often turns cloudy for a while ere the constituents of each sample incorporate thoroughly with one another, and it is advisable to proceed soon after to fresh racking.

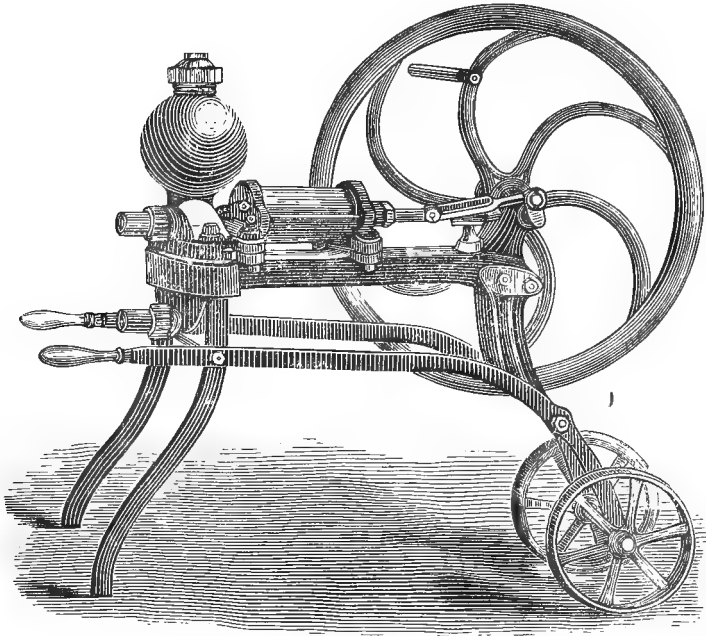

Wine Pump.

Occasionally a sort of mishap occurs to wine after the racking, and this is known as *cassage des vins*, or in other words the colour is said to "break." Thus, red wines are noticed to turn violet and assume a leaden colour, although the taste is not modified. White wines are affected as well, and assume a bluish or a blackish tinge of colour. This phenomenon is simply due to the oxidation of certain matters, in some wine produced from imperfectly matured grapes, which are affected by the air. After a little while that cloudiness disappears, and the healthy colour of the wine is restored back to it. Sulphur, as has been previously mentioned on page 440, offers an easy means of preventing the accident. In some cases, however, this discolouration persists, unless a small dose of tartaric

acid or one-third its weight of citric acid is added. The acid, acting on the colouring matter, keeps it in solution; the dose used varies generally about one gramme per litre, or about 60 grains per gallon. Pasteurisation at 65deg. C. (150deg. F.) will cure this as well as any other disease.

Of pumps, the simplest are the best. In any case the valves should be easily accessible to free them, whenever required, of any obstruction to their proper working. Danks' ordinary, power-driven, double-action gun-metal pump are very good, and used at many of the Victorian wineries.

#### PARAFFIN FOR PUMPS, PIPING, VATS, AND CASKS.

Paraffin wax provides a servicable and cheap way of getting worn out rotary pumps to work and protecting black iron pipes, sometimes used for racking wine from large vats or casks; they are better than galvanised pipes which have a zinc coating and they are also cheaper. Mr. F. de Castella states that he used them extensively at Dookie, where pipes were fixed everywhere permanently with a good fall and a plug for clearing after use, at the lowest points. For that purpose the pipes or pumps are made hot, the paraffin wax is melted and poured into them, and they are tipped every way and finally the surplus paraffin is poured out. At some wineries the pipes are re-paraffined every year, while at others it is found that one good application lasts several years.

Vats and tanks may be similarly treated, the melted paraffin being put on with a brush and spread evenly over the surface by means of the blow-lamp.

#### ULLAGE IN CASKS.

It is essential when the wine has fermented out to exclude further access of air which may carry injurious germs or bring into action others which may be in the wine. When the wine is young it is charged with carbonic acid gas with which it parts gradually, and a noticeable shrinkage of volume results. That ullage must be filled every week or two at first, then every month. This shrinkage and evaporation are influenced by the season, the volume of the wine vessel, the age of the wine, more in summer, less in winter; it is greater in wooden casks, especially new, than in cement vats where it is very small.

It is a good plan to place round the bungs or plugs a cement made of mutton fat and resin in the proportion of 3 to 1; some prefer a ring of liquid ordinary lime and sand mortar round the plug. This cement soon cakes dry and is easily removed.

If the wine is not clear and bright at the time of the third or spring racking, there is generally something amiss, and it should receive attention and be fined or even pasteurised unless it is preferred to fortify and blend it with sweet wine.

## FINING AND FILTERING.

Young wine, even when sound, generally lacks that clearness and brightness which characterises a well made and matured wine.

*Condition* is the name given to the state of clearness of wine. It means the degree of limpidity or the amount and character of suspended solid matter it contains.

1st. Immediately after fermentation a wine is said to be "murky" or "muddy."

2nd. After most of the yeast and other sediment have settled it is said to be "cloudy."

3rd. When sufficiently freed from floating matter to be transparent it should be "clear." When properly fermented this appears within three or four weeks in the case of a white wine.

4th. The final stage is reached when no floating particles are visible; the wine is then "bright."

It is important to bring about a good condition in the young wine before the advent of hot weather revives the injurious germs which might still be present, and this purpose may be attained by *fining*, by *filtering*, and by *Pasteurising*.

These methods may be used either singly or conjointly. The first two will be referred to briefly now, the latter in a subsequent chapter.

"*Fining*" is brought about by the use of albuminoid substances, which are reduced to a solution and, mixing with the wine, are coagulated by the spirit and the tannin into insoluble flocculent mesh-like film, of a density slightly greater than the wine, which, on settling, gradually drags down the solid particles in suspension, leaving the wine above clear.

If *fining* fails to act, it may be due to several causes, viz.: 1st, deficiency of tannin, particularly in white wines fermented apart from the skins; in this case it is essential to add tannic acid a day or so before *fining*. 2nd, The young wine is still charged with carbonic acid gas which, gradually disengaging, forms little bubbles which prevent the *fining* from settling down; racking in the presence of air will remedy this. 3rd, The wine may contain active germs of disease which, being at work, create a movement in the wine and produce gases which also prevent the settling of the *fining*. When this is the case, sulphiting by means of sulphur fumes, or the application of meta-bisulphate of potash, will paralyse the germs and permit the *fining* to act. Subsequent rackings will free the wine of these sulphur fumes. A surer method is pasteurising, *i.e.*, bringing the wine rapidly to a temperature of 150° to 170° F., and cooling it also rapidly. This operation is conducted out of contact with air by means of a specially constructed machine.

The fining material used, as already mentioned, consist of albumenous clarifiers, viz., several albumens, white of egg, blood, milk (casein), gelatine, isinglass.

The patent finings offered by commerce consist of one of these substances with tannin and potassium sulphite added; they are good, but their price is often unreasonably high.

*Fish Isinglass*, called by the French *Ichthyocol*, is very good for white wines; one quarter to half an ounce per 100 gallons for white wines. It is split in thin sections or, better, rasped, covered with cold water for 10 or 12 hours, during which it swells, then boiling water is added, beating it meanwhile. Another way is to dissolve one-tenth its weight of tartaric acid, plunge the isinglass into the acidulated water, but without heating it, and avoid beating it at this stage. In about an hour it is reduced to a clear, transparent jelly; then stir and reduce to the consistency of thin cream and stir it into the wine. When ready for use some wine is well mixed with it and it is poured into the cask, which is stirred energetically with a plunger. A quantity may be used for subsequent use, and 1 per cent. of bisulphite of potash added to preserve it.

*Gelatine*.—One to one and a-half ounces per 100 gallons of either white or red wine; the amount depends much on the degree of cloudiness. It is sold in the shape of yellowish to transparent cakes. It swells without dissolving in cold water, but dissolves very readily in warm water. In the proportion of 5 per cent. the dissolved gelatine remains liquid at ordinary temperatures; if more concentrated it jellifies on cooling. Dissolve the quantity required, dilute with wine and stir into the cask. The tannin and acid of the wine cause a gradual coagulation, the particles settling and carrying down the solid matter floating in the wine. The coagulum consists of a combination of the gelatine and the tannin. With astringent red wine this may be an improvement.

*White of eggs* are used without preparation other than beating up with water. The white of 10 eggs may be used for 100 gallons of wine.

*Fresh blood serum*, i.e., the clear amber-coloured liquid which separates after coagulation, is used without any further preparation; half a pint to 100 gallons, with a quarter of a pound of common salt added. The desiccated forms of eggs and blood albumen found in commerce are expensive, and lose the simplicity of their manipulation when liquid.

*Natural milk* is only used for the clarification of *vinegar*. Gelatine requires about equal quantity of tannin to precipitate. Isinglass, properly prepared about half that amount. Eggs require only minute quantities.

When the wine has cleared, after three to ten days, it is drawn by racking from over the lees.

## FILTERING

is a convenient and expeditious way of bringing to a bright condition wines which are not quite clear, provided that this defect is caused by inert solid or viscous matters in suspension in the wine or by yeast cells, but not by the presence of active microbes of disease. These must be paralysed or destroyed by sulphiting or, better still, by heat in properly constructed pasteurisers.

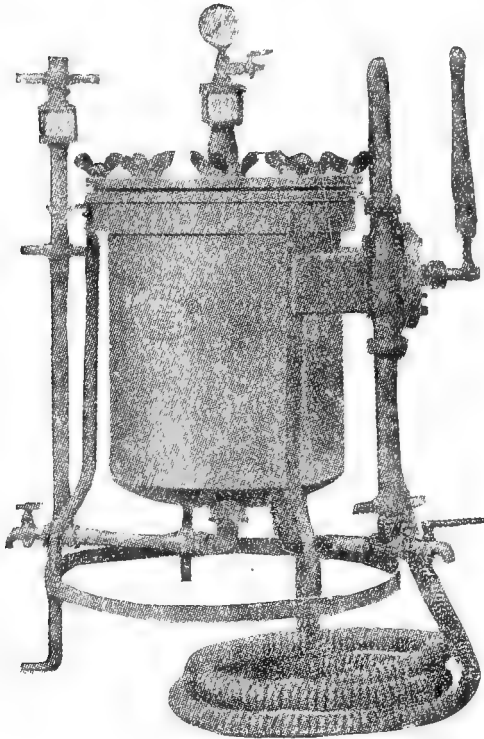

Dondey and Testro's Filter.

Wine filters consist of bag strainers coated with cellulose and asbestos, or specially prepared paper paste, or a mixture of cellulose and infusorial earth, or else they are made of porous and hollow pipeclay bougies. It is an advantage to conduct the filtration out of contact with air, to guard against the loss of alcohol and of the volatile bouquet of the wine. The Simoneton filter, made in France, is a candle filter, and much used.

Another efficient filter, made by Dondey and Testro, copper-smiths and stillmakers, in Melbourne, is here illustrated. The filtering paste is placed inside the filter and the wine is forced through under the force of gravitation or of a small pump attached to the filter. Other models are also found which are quite efficacious.

If the wine does not run clear at first it is passed through again, and the machine can be worked until the run becomes too small and the filtering material becomes clogged, when the filter is opened, washed, refilled with new filtering material, or with the same after scouring it and squeezing out the water.

When it is suspected that the filtered wine is not sound, the cellulose packing, bags, and filter itself should be disinfected and treated with hot steam or boiling water.

It is an advantage to fine the wine prior to filtration; better result is thus achieved. When infusorial earth is used it is recommended to add some gelatine as a support.

Filtering is more generally used by merchants than by wine-makers, who generally use a fining material for conditioning their wine.

#### LEES AND TARTAR.

After racking there is left in the bilge a varying quantity of muddy lees and of wine, containing as much as 70 per cent. of wine and 30 per cent. of dry sediments. That wine, after fining, filtering, and sulphuring, can be put on the market or put through the still. As for the solid residuum it can be stored and sold for extracting tartaric acid and cream of tartar. According to analysis, air-dried lees obtained from claret wines contain on an average—

Bitartrate of Potash ...	...	...	18 per cent.
Tartrate of Lime ...	...	...	7 „
			25
			—

In addition there is sulphate of lime 15 per cent., organic matter 33 per cent., containing nitrogen 4 per cent. Fifty gallons of wine will deposit at least one gallon of lees, four-fifths of which will be wine, one-fifth solid sediment, consisting of bitartrate of potash and tartrate of lime, and of debris of dead yeast, etc., representing about 4 per cent. of nitrogen of value as manure.

The separation of lees is very simple. The muddy wine is either poured into a canvas filter previously steeped for a few days in soda or potash lye, and afterwards into lees with tartaric acid added, and then washed. This will rid it of its peculiar taste. The liquid wine collected is placed into a well-sulphured cask, or again

the thick lees are poured into casks—one for red and one for white lees. After a few days subsidence, the liquid wine on top is syphoned off, and the residuum placed into canvas bags and allowed to drain. That residuum is then dried in the sun or in a kiln, and presents the appearance of minute crystals, which can be kept until such time as it is sold, or when a sufficient quantity has accumulated and is available for treatment. The market value is directed by the percentage of the bitartrate, from which tartaric acid and cream of tartar are extracted.

The tartar obtained from the crust deposited in the casks is not treated and may be sold as such.

In the larger wineries it is of advantage to extract crude bitartrate or cream of tartar from the dried lees, as the value of the tartar per unit is always less in the lees than in cream of tartar, which goes up to 80 per cent. strength, while the residue can be restored to the vineyard as manure.

These extraction of tartar from the lees can be readily effected and requires a large boiler and casks. To economise fuel the hot water running from the cooler when the still is at work may be used in the boiler. The strength of the lees being ascertained by a rough test; it is boiled with rain water, the quantity of lees used representing about 7 per cent. of pure tartar in the quantity of water used.

In the case of lees generally going 25 per cent. of tartar,  
100 x 7

———— = 28lbs. will be boiled in 28 gallons of water. The quan-

25 tity need not be quite accurate. After quarter of an hour's boiling, during which the mass is stirred, it is allowed to settle for a few minutes and the clear liquid, now containing nearly all the tartar in solution, is poured into open casks or vats to cool, the residue still containing the nitrogenous matter may be thrown over the manure heap or straight on to the land. On cooling the boiled liquid casts as crystals almost the whole of the tartar in solution, the water is allowed to run and the cream of tartar collected.

The rough test for ascertaining the quantity of tartar in dried lees is based on the same *modus operandi*. An even sample of the lees having been obtained, 50 grammes is carefully weighed, pulverised in a mortar and placed in an enamelled pan of about 1½ quart capacity. One quart of rain water is added and brought to the boil for about 10 minutes, stirring all the while. The tartrate dissolves, while the impurities settle at the bottom. The liquid is strained over a silk sieve and the liquid, which is collected in an enamelled pan, is allowed to cool for 12 hours. A crystalline crust forms over the mother liquid; it is broken and carefully collected from the bottom of the enamelled pan after the liquid has been poured off. The crystals are placed in the open oven to dry at a mild temperature and they are finally weighed, multiplied by 2 to

bring the weight to per cent. To the product, 10 is added as representing the coefficient of loss, and the percentage of the tartar is thus roughly ascertained.° That loss is represented in the tartar still in solution in the mother liquid and need not be repeated if the same water is used in the subsequent boiling. Thus if 23 grammes of crystals have been collected and weighed we have  $(23 \times 2) + 10 = 56$  per cent. or the degree of tartar in the lees.

#### DEFINITIONS AND CLASSIFICATIONS OF WINE.

*Wine* is the product of the normal alcoholic fermentation of the juice of sound, ripe grapes, and contains not less than 7 nor more than 16 per cent. of alcohol by volume (12.5 to 28° proof spirit).

*Red Wine* is wine containing the red colouring matter of the skin of grapes, such wine contains more tannin and more extract than a white wine fermented without the skins.

*White Wine* is wine made from white grapes or the pressed juice of other grapes.

*Dry Wine* is wine in which the fermentation of the sugar is practically complete and from which sweetness to the taste has been eliminated.

*Sweet Wine* is wine in which the alcoholic fermentation has been arrested, and one in which sufficient sugar remains after fermentation to give a noticeable sweet taste.

*Fortified Dry Wine* is dry wine to which brandy has been added.

*Fortified Sweet Wine* is sweet wine to which wine spirits have been intentionally added to prevent the further fermentation of a portion of the sugar, which may range from 2 or 3 per cent, to 10 per cent. or more. A few wines of this class are made without fortification by the use of very sweet grapes.

*Sparkling Wine* is wine in which the after part of the fermentation is completed in the bottle, the sediment being disgorged and its place supplied by wine or sugar liquor. The wine is made by practically the same process as dry wine and the sparkling quality given later by supplementary fermentation in the bottle. Champagne, the typical sparkling wine, contains sufficient dissolved carbonic acid gas to cause a pressure of five to six atmospheres in the bottle.

*Raisin Wine* is the product of the alcoholic fermentation of dried grapes.

A wine to be legal must conform to these standards and to other regulations of pure food laws.

Names drawn from particular vineyards or from localities or regions are proprietary and should not be used elsewhere, such as



Chateau Lafitte, Clos Vougeot, Burgundy, Medoc, Hermitage, Champagne.

*Port* has become a well known trade name, the use of which elsewhere than at Oporto is debatable. Provided the wine is made of suitable grapes in the recognised way and is of the type of the sweet fortified red wine exported from the banks of the Douro, it has been suggested that the name of the region where such wine is made should be prefixed with the regional name, in fairness to the consumer and to the country which gives the name to the wine of Oporto.

*Sherry* is a corruption of the older spelling Xerez, *i.e.*, Jerez de la Frontera, the initial X being pronounced almost like "ch" in Southern Spain.

"*Claret*" was originally applied to the red, dry, light wines of the Medoc, a term not now used in the modern French language. The old French "*clairet*" is from the low Latin *claretum*, and signified a wine "cleared" with white of egg, etc. Old French remained the language of the English court and law courts till the reign of Edward III., and the word "*claret*" has been retained in England long after its disuse by Frenchmen.

*Brandy* is the distillate of wine, properly aged by storage in wood. It is a term unknown in France, where this spirit is called "*eau-de-vie*." Brandy, formerly called "*brand-wine*" and brandy wine, is from the Dutch *brandewijn*, literally burnt or *distilled* wine.

#### HOW TO TASTE WINE.

Before venturing to give an opinion, the experienced taster looks at and thoroughly examines the wine, making note of its condition or degree of brightness. If bright and brilliant the wine has been well clarified and rid of the germs which might impair its quality. If cloudy and dull it is a sign that it has not been completely purged of its impurities, and unless carefully handled might generate symptoms of diseases.

He then considers the colour, the foam; if sparkling wine, the degree of effervescence. The colour should be a natural one, and not one of those composite shades made up of the blending of two or more natural colours. If red the colour should be ruby or garnet; yellowish red, rusty or opalescent wines designate a decrepit wine, or one in a more or less advanced stage of disease.

Having satisfied the eye he proceeds to investigate the nature and degree of the aroma and bouquet. This he gets by gently agitating the half-filled glass, or twirling it and smelling the wine carefully, sometimes by placing the hands round the glass so as to warm it gently; the more delicate and volatile odours of the wine are given off and detected.

Then comes the crucial part of the examination—that of tasting proper.

As expressed by Dr. Guyot, epicure and high authority on wine as well, the mouth, which is the seat of tasting, is capable of detecting impressions of complex kinds. In this it is assisted by the tongue, the gums, the palate and the inner part of the cheeks; the flavours, moreover, detected by the tip are of a different nature from

those which affect the base of the tongue. In order to differentiate between these different savours, the taster takes into his mouth a sip of the wine, and keeps it for a moment in the anterior part of his mouth, where the sense of taste receives its first impression. Then, with the tip of the tongue, he spreads the wine out into a sort of film against the roof of the anterior part of the palate, subdivides and breaks it up, as it were, in order to increase the surface of contact with the delicate nervous expansion that lines the membrane of that part of the mouth. There sweet, saltish, acid and astringent impressions are received, and he perceives whether the wine is dry or sweet, acid and tart to excess or satisfaction, too styptic or poor in tannin. The sensation registered in that part of the mouth also indicates whether these three elements are harmoniously blended, or whether there is excess or deficiency of either one or two of them.



Vellinche.

This having been done, the wine is allowed, by slowly raising the head, to pass to the posterior part of the mouth, and a little inhalation of air is at the same time taken in. This may cause the tyro to choke, by diverting some of the wine into the wind passage, but he will soon get over this difficulty. By the time it reaches that part of the mouth, the wine has been gently warmed and mixed with air, it gives off savours different to those perceived in the anterior part of the mouth. Here the strength or the weakness of the wine in spirit or its vinosity will be noticed; also any specially pleasant or unpleasant characteristics of the wine as the earthy taste, bitterness, mawkish, mouldy, woody, or corky tastes. The taster, having satisfied himself as to the presence or absence of these tastes, may, if he chooses to further carry on the degustation, then let a few drops of wine pass down his throat, when he will detect the *sève*, which is distinct from the "flavour," in this much, that it is affected by both the taste and the sense of smell, in passing down the base of the tongue and the posterior part of the palate, and in coming into contact with the mucous membrane that lines the pharynx, a distinct ethereal savour ascends to the palate as well as

to the internal nasal ducts. This sensation, according to the wine, is more or less short and evanescent.

Besides these sensorial impressions made by the wine on the organ of light, smell, and taste, there is a physiological one as well, quite independent of these, and which affect the digestive organs, the locomotory muscles, the heart and the head, and we often hear the uninitiated declare that they know little or nothing about wine, but they can tell next morning whether it is good or not. The sensation is too well known to be described in these notes, but nevertheless the physiological after effects is certainly of value in discriminating between good and bad wine.

The wine taster can't afford to indulge in luxuries of all sorts before proceeding to taste wine. The best time to pass judgment on wine is in the cool of the morning, when the body has been freshened up by the night's rest. Salt meat, pickles and condiments should be sparingly used by wine tasters, and they should above all things refrain from indulging in strong spirituous liquors. Some pretend they can taste better just after smoking, but the experience of most tasters is that tobacco just before sampling wine impairs the senses of smell and taste.

A taster can't do more than a limited number of samplings in the forenoon's work, and whenever his palate is clogged, a dry, small piece of unsweetened biscuit and mild cheese are good to clear the palate. Sometimes an olive, when not cured in strong brine, may be chewed and rejected, but a mouthful of cool, clear water is above all things the best for cleansing the mouth should the palate become clogged during tasting.

#### SOME TECHNICAL TERMS IN WINE-TASTING.

There exists amongst wine-growers, merchants, tasters, and connoisseurs, like in every art and science, a language of their own, which serves to express the qualities or the defects of wines, and which is composed of terms somewhat technical, some of which will be better understood when explained.

#### QUALITIES AND DEFECTS WHICH AFFECT THE SIGHT.

First, says Profesor G. Grazzi-Soncini, notice the Foam which forms on the surface of the glass, small beads which burst more or less rapidly.

**FOAM.**—An agglomeration of gaseous bubbles which float and move about on the surface of freshly poured-out wine, and adheres in a ring round the edge of the glass or floats in patches in the centre of the glass,

*Persistent Foam* is the reverse of evanescent foam, and is the characteristic of a wine of low alcoholic strength, kept at a low temperature; it may also be a sign that the wine wants racking, or it may be due to the fact that there is a secondary fermentation either of a healthy or an unhealthy nature that is taking place. It may, when it forms a finger nail on the surface of the wine be a symptom of what the French call the *Maladie de la Tourne*.

*Sharp Pungent Foam*.—It may go on briskly, and in that case when drunk has a smarting or prickling effect on the palate.

*Frothy*.—Formed by an accumulation of gas bubbles which forms on the surface, especially wine bottled too young, or in which there was a small amount of sugar left.

*Sparkling* is an evanescent foam, the bubbles of which burst and are as quickly renewed, forming sort of pearls on the surface, as occurs in champagne.

*White Foam*.—Generally associated with matured or old red wine, but in some localities occurs in young wine.

*Rose Foam*.—Accompanies matured wine, but occasionally pale young wines.

*Red Ruby Foam* indicates full-bodied young wines deep in colour.

*Bluish*.—In wines poor in acid, as in some blending wines, containing only 3 to 4 p. 1,000 of acidity.

The LIMPIDITY of the wine is next observed:—

*Clear*.—A transparent wine, without cloudiness. There are in clearness, degrees of comparison which can be noted.

*Bright, Brilliant*—as when the degree of clearness is such as to be perfect. This may be the result of fining, filtering or standing still for a long time in a cool and an even temperature.

*Cloudy, Dull*.—The reverse of clear. Wines freshly racked often turn a little cloudy for a while, owing to the oxidation of some of the albuminoid matters they contain, more especially wine from fleshy grapes grown on rich flats, also in wines poor in acid, and which have not completely fermented.

*Turbid, Thick*.—When the particles in suspension are so numerous and big as to be easily seen and make the wine opaque. Either a perfectly new wine or wine bottled too soon, and that has left a muddy deposit on the side of the bottle—sometimes the result of putrid fermentation. In the case of an old wine bottled too soon, raise the bottles

carefully and in the same position they have been lying; remove the cork without any jerk, preferably with a screw corkscrew, and draw the clear wine carefully into a decanter or a clear bottle, or else, with a small glass syphon, made for the purpose, separate the clear from the murky wine. Unless the precautions are taken, the wine will, after two or three glasses have been poured out, be quite turbid and very unprepossessing in appearance.

*Opalescent, Iridescent.*—Is generally an indication of unsoundness, and not infrequently due to the disease called in France *la pousse*, in which a tartaric fermentation takes place, the colour is precipitated, and a flocculent growth of microscopic, rod-like bacilli float about the mass of the wine, which assumes a sickly brick colour, and breaks up the rays of light as they penetrate the wine, causing that iridescence.

As regards COLOUR, a wine is either:—

*Colourless, discoloured.*—When it has almost the appearance of pure water. This is obtained by very carefully handling white grapes, or sometimes by running the new wine over animal charcoal, although this is very seldom done except for special purposes.

*Straw-coloured.*—A very common and pleasant colour.

*Yellow.*—Often the sign of a wine poor in alcohol, tartar, and may be tannin or acid: in that case the iron compounds in the wine are, when acted upon by the oxygen of the air, turned into yellowish-brown compounds. In the case of disease it can be prevented by the addition of alcohol and tartaric acid.

*Golden Yellow.*—Very often observed.

*Greenish.*—Characteristic of certain varieties of grapes.

*Pinkish Yellow or Russetty Yellow.*—Often due to imperfectly cleansed wine-casks and vessels.

*Rose-coloured.*—White wines made from red grapes, without much care, or stored in red casks improperly decolourised.

*Brown-yellow*, which the French call *oeil de perdrix* (partridge-eye), is a sickly, dull, dark-yellow. Either due to a malady of the wine caused by a mycoderm—in that case raise the alcoholic strength, add ten or twelve grammes of tannin to the hogshead of wine, let it rest for a day or two and fine with isinglass—or sometimes caused by the presence of an excess of iron in the white wines, or found in wine made from grapes poor in tartaric and other natural acids, or from partially decayed grapes.

*Dirty-dull.*—A diseased, badly made, or badly kept wine.

*Light-red.*—The French *clairer*, has been either made from unsuitable grapes or often is the result of the addition of water.

*Ruby.*—As represented in the well-known Bordeaux or claret wines.

*Purple* is a ruby wine with a tint of violet in it.

*Garnet-red.*—Represented in the fuller bodied wines as in Burgundies. These wines are long-keeping, and show a tendency to acquire an orange tint.

*Orange, Yellowish-red, Rusty.*—Generally denotes a decrepit wine.

*Dark Coloured* wines have an excess of colouring matter; generally harsh and indigestible.

SMELL AND TASTE combined detect:—

*Aroma* is due to the essential oils which are contained in small glands that line the inner surface of the berries. They are common to both the grapes and the wine, and may be of a pleasant or an unpleasant nature, viz., Muscat, Riesling, or the foxy flavour and smell of the Isabella and other American grapes.

*Bouquet* is due to the reaction of the acids in the wine on the alcohol, and the production of volatile ethers which are better noticed in the older wines, especially those bottled for some time.

*Sève* or *Fragrance* is neither Bouquet nor Aroma, and is present in the finer wines; it is experienced and can hardly be described, and consists in a fragrant savour which rises to the nasal ducts during the act of swallowing a good wine. Aroma and Bouquet are detected before tasting, whereas *sève* is noticed after drinking the wine.

The sense of TASTE proper, and more especially the tongue, distinguish:—

\* *Flavour.*—Unlike the Aroma, the Bouquet, or the *sève* or *fragrance*, the flavours are detected without the assistance of the sense of smell. They are either pleasant or unpleasant, according to the nature of the flavours and their degree of intensity.

*Neutral Flavour* is characterised by neither aroma nor any special taste, and such wines, which are generally the produce of heavy bearing vines, are mostly suitable for blending purposes.

*Inspid, Flat.*—A wine without vinosity and liveliness. Wine left long in open bottles and decanters, or a wine that has been too energetically fined, often turns flat. They are in that state more subject to contract disease.

*Vinous, Vinosity,* is that sensation of warmth characteristic of the alcoholic flavour.

*Weak* wine is not a light wine. It is a wine of low alcoholic strength, or when its alcoholic contents are not in proportion to its other chief constituents. Such wine is more or less inspid, and its taste is short and of no long duration in the mouth. It is generally of difficult keeping unless fortified.

*Light* wine is often a dry wine of good quality, with its various components well balanced and harmonious, but lacking in quantity. It is as a rule somewhat deficient in colour, body, alcohol, acids, and bouquet.

*Soft, Mild,* is a wine that does not affect the palate by its harshness and astringency. It is characteristic of a wine that is neither sweet nor dry nor too alcoholic.

*Alcoholic.*—A wine with a high proportion of spirits to its other constituents, such as a fortified wine, or a wine made with over-ripe grapes; compared with the flavour detected by the mouth, the aftertaste is of short duration.

*Generous.*—A wine with a good proportion of alcohol as well as of its other constituents, which imparts a feeling of warmth and strength-giving—a good tonic wine.

*Lively.*—Which makes a quick impression on the palate, generally a wine with an adequate proportion of acids and alcohol.

*Full-Round.*—What the French call *Etoffé*. A robust, harmonious wine, which gives the impression of solidity and good constitution—a tonic wine—a quality possessed by Australian wines made from good sorts of grapes and well fermented.

*Body.*—A wine of good vinosity and rich in extractive matter. Generally sticks to the glass like beads.

*Heady.*—Generally a young wine still saturated with carbonic acid, and having a good proportion of newly-fermented raw and somewhat fiery alcohol, which has not yet had time to refine. Should be drunk of with moderation.

*Heavy.*—A wine surcharged with extractive matter and low in alcohol, and which is hard to digest.

- Clean.*—A sound wine, which has no earthy, mouldy, or casky taste, or any taste foreign to the wine itself.
- Harmonious.*—A quality of wine whose constituent elements are well balanced and blended together.
- Delicate.*—A soft, pleasant, harmonious wine, generally delicate.
- Mute.*—A partially fermented wine, with a sweet and mucilaginous taste, which has been stilled by means of concentration or by means of alcohol, or of sulphur fumes, or other chemicals. Too much sulphur sometimes generates hydrogen sulphide, which reminds one of rotten eggs, or leads to the formation of sulphates, which impart to the wine bad flavours.
- Fruity.*—A wine which still retains a proportion of grape sugar.
- Sweet.*—Of which there are several degrees, extending from “fruity” to “sickly sweet.”
- Sweetish.*—Wines, in which the fermentation has suddenly got “stuck” before being completed, turn sweetish. This is due to the formation of manna sugar, resulting from the decomposition of the mucilaginous or albuminoid matters in the wine by alcohol, owing to the agency of a bacillus, and under the influence of a high temperature. The trouble is known as that of “mannitic” disease.
- New or young Wine.*—A wine freshly made; generally from one to twelve months old; a wine that is still rough and has not been purged of its impurities, and has not yet developed those finer qualities that will distinguish it as a mature wine.
- Mature Wine.*—A wine which has undergone the refining changes due to oxidisation and warmth, and has cleared itself of its lees, and is ready to be drunk or to be bottled.
- Decrepit Wine.*—An aged wine that is losing some of its qualities through long keeping, or rapid and excessive changes of the temperature.
- Tart.*—Due to the presence of an excess of tartaric acid. Age modifies this defect.
- Dry.*—Not sweet, *i.e.*, containing no grape sugar, slightly astringent.
- Astringent.*—Where the tannin predominates.
- Rough, harsh.*—A wine astringent to excess; diminishes with time.



*Bitterish.*—A densely coloured wine, rich in tannin, like the malbec wine. (Generally disappears after the first rackings and a fining.)

*Earthy Taste* is detected in the posterior part of the tongue; it is either due to the soil, the manures used, or the weeds infesting the vineyard, and is located chiefly in the skins. Prolonged maceration of the skins in the fermenting must develops it. Prompt fermentation and separation of the skins from the wine, rackings and maturing reduce it.

*Cooked Taste*, as of caramel. Due either to the boiling down of the must, or by an over-ripening of the grapes in very hot weather.

*Mousy Taste.*—A disagreeable odour and flavour suggestive of mice; generally due to unclean and mouldy casks. Beating with pure olive oil and pasteurisation will partly correct it and stop its progress.

*Sulphur Smell.*—Due to excess of sulphurous acid used, turning sometimes into hydrogen sulphide, and smells of rotten eggs. Racking at frequent intervals will reduce the taint. When used excessively, sulphur fumes destroy the colour and impart to the wine a displeasing taste. In time sulphurous acid changes to sulphuric and then into sulphate of potassium.

*Artificial Odours.*—Added to the wine to impart to it a certain fictitious bouquet, generally not successfully. Have not the fragrance of true bouquet and *sève*.

*Wood or Cork Taste.*—Given to wine by new, ullaged, or by mouldy casks. Olive oil, lemons, or refermentation with a small quantity of fresh grapes will sometimes reduce it.

*Taste of the Stems or Stalks.*—Due to prolonged maceration of the stems or stalks in the wine. Generally a harsh, bitterish wine.

*Taste of Lees.*—Want of racking by allowing the wine to stand long on the lees, produces a bitterish taste of decay. Common defect of many otherwise very good Australian wines.

*Mouldy Taste.*—Caused by bad casks or mouldy grapes; beat with olive oil and rack in clean, sound casks.

*Sharp, Sour, Pricked.*—A wine with an undue proportion of acetic acid. Generally retains its colour and limpidity. Characterised by the odour and taste of acetic acid, which is chiefly perceived at the base of the tongue. It is easy to prevent the development of the micro-organism which

causes it, by due attention in the vat and the cask; but once a wine is pricked it should, says Dr. Guyot, "be sent to the vinegar factory, and never attempt to use it as wine." The remedies proposed are only palliatives, but are not radical cures. Pasteurisation will stop it, but won't remove the acetic acid in the wine. "Even after its neutralisation by means of alkaline substances the wine will still have an odour of acetic acid, accompanied besides by a bitter taste which lingers in the throat."

*Milk-sour, Lactic Acid.*—A sickly rancid, sour-sweet taste, caused by lactic fermentation, which takes place in wine that has fermented at too high a temperature. A milk-sour wine loses some of its fluidity, and its colour becomes dull. Pasteurising will check the disease, but it is almost impossible to take away the defect of milk-sourness.

#### GEROPIGA.

During vintage a stock of grape syrup is sometimes laid by for the purpose of sweetening any port wine lacking in fruitiness. For that purpose, crush dead-ripe grapes and press out the juice, evaporate on a slow fire in a copper or an iron boiler, heating to a simmer to prevent the formation of caramel and keeping the surface well skimmed. When the bulk is reduced to half its volume, add more grape juice, and continue simmering until syrupy, with a specific gravity of 25deg. B, then fortify to 32deg. proof.

By carrying the concentration to 32deg. Baumé, the grape syrup will keep. This preparation is known as *arropa* in Spain, and is used in the manufacture of Malaga wine. In Italy, under the name of *sapa*, it is used for a similar purpose.

#### PIQUETTE FOR DISTILLATION.

The pressed marc or cake made up of the skins from the fermenting vates still contain a notable quantity of wine which cannot be extracted by the press but which can profitably be made available for the still without impairing the value of the residue for the feeding of stock or as a manure. One ton or 2,240 lbs. of fresh grapes will yield about 1,300 lbs. of wine and 700lbs. of marc or skins and pips. From this marc another 20 to 30 gallons of wine can be utilised for the spirit it contains. Two methods are employed for that purpose :—1. Driving the alcohol direct from the marc by means of steam and condensing the spirit. 2. Washing out by a process of lixiviation or of diffusion.

The first method is, of course, carried out in closed retorts.

The second consists of a battery of four or five vats, either wooden or made of reinforced concrete and built on the same level. They communicate with one another by means of pipes. The vats

are filled with pressed skins, and a small stream of water is run over the top of the first one. When full the liquid running at the bottom rises and is conducted by the pipe to the top of the second vat, the small stream of water running all the while on the top of the first vat. In time the second vat is filled with the liquid which had been in contact with the marc in No. 1, and in turn it rises from the bottom of No. 2 to the top of No. 3 by means of the connecting pipe; the same thing happens in No. 3, the liquid gaining strength by virtue of being for the third time in contact with fresh skins, whereas the liquid in No. 1 and in No. 2 become gradually weaker and weaker. This goes on until all the vats are full, the overflow from the last one consisting of a mixture of wine and water of a strength almost as great as that of the wine held by the fresh pressed marc. It is ready for the still.

No. 1 vat having become exhausted of wine, the liquid consisting mostly of water, it is disconnected, emptied, and refilled again with fresh marc and becomes the recipient of the next stronger solution which, in turn, is collected and distilled.

No. 2 vat having become No. 1, therein is run the water, which automatically drives before it the contents of the vats following; when it also becomes exhausted it is emptied and refilled again with marc. The process goes on uninterruptedly while there is fresh marc to treat.

A very satisfactory plan and section of such a diffusion battery, for the exhaustion of grape marc, designed by Professor L. Roos, Director of the Oenological Station, Montpellier, is given below.

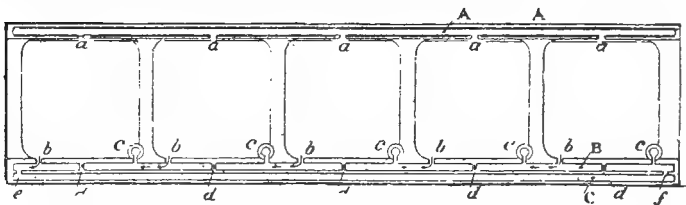
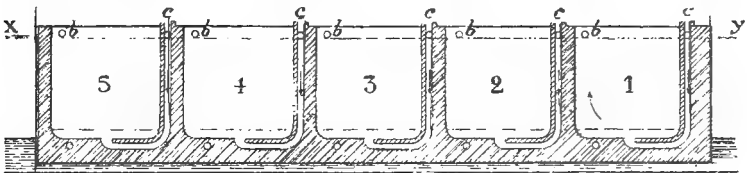

GRAPE SKINS INTO MANURE.

Professor Roos, of Montpellier, recommends the following compost as a complete manure, assimilable in every soil, as it brings with it the alkalinity suitable for nitrification.

If skins have been used for making piquette or have been exhausted of spirits by the diffusion method, cart away and let drain for a couple of days. Spread over the ground a layer one foot deep. Broadcast over this 4 per cent. basic slag or basic superphosphate (super with 7 to 8 per cent. of slaked lime mixed) and 2 per cent. sulphate of potash.

In an open barrel prepare an artificial lye as follows:—

Water	..	..	..	..	25 gallons
Quacklime	..	..	..	..	2 lbs.
Sulphate of ammonia	..	..	..	..	5 lbs.

Slake the quicklime with a little water and make gradually into a lime milk and add the sulphate of ammonia and rouse with a stick till dissolved—about quarter of an hour—and the lye is ready.

Water copiously with this lye the first layer of skins and build up another layer, to which apply the same treatment; the topmost layer cover with a few inches of earth. After a little time the temperature rises and fermentation sets in. After three weeks cut the heap across to build it up again alongside. This mixes up the stuff and fermentation starts again, though not so active, and the marc becomes more friable. Fifteen pounds per vine planted 8ft. apart constitutes a complete measure.

#### AMATEUR WINE BOTTLING.

Bottled and cased wine is often costly, the consumer having to pay for bottles, corks, capsules, labels, and cases, and also the cost of the labour entailed by these operations. Wine bought in wood, on the other hand, particularly light wines such as claret and light white wines, often proves more costly still to those who, through want of experience and neglect, fail to observe ordinary precaution for its safe-keeping.

Wine in bulk and bought in cask is also cheaper than smaller quantities sold by the case. The wine-maker or the wine merchant generally allows the full amount for casks returned in good order, so that by buying in bulk and seeing to the bottling himself, the consumer can stock his cellar with good sound wine at a reasonable cost. Instead of paying 2s. 6d. and more a bottle, he can lay down a stock of wine at half the cost.

A few notes on the question of the home-bottling of wine will enable many to procure sound wine at a small cost and bottle and keep it until required for use. Instead of deteriorating, such wine keeps on improving when thus put away.

Having procured the particular kind of wine desired—

*Be ready for bottling.*—The cask having reached the cellar, place it on a small stand at a height of 15 to 18 inches from the ground. Collect bottles or buy them. For home use, it is immaterial

what shape or colour the bottles are. French claret bottles are expensive, but brandy or whisky bottles answer just as well, or even beer bottles. The bottles are easily cleaned. It often happens that they have a cork inside; this is easily removed by using a special cork drawer made of wires armed with a spike or hook at the end, and costing 1s. or thereabouts. The bottles are placed in soak in water containing a small handful of washing soda for each gallon; they are then cleaned of stains and crust by using small shot or coarse sand and water. It is important that no shot be left in the bottle, as the action of the acid in wine on the shot would result in the wine containing in solution salts of lead, which are highly poisonous. When cleaned, the bottles are rinsed in fresh water and placed in cases, in baskets, or on crates to drain.

*Corks* are also required; these vary in texture and in shape. If a powerful corking machine is available, a larger cork is preferable; if not, tapered corks should be procured; they cost from 3s. to 4s. per gross. Beer corks, which are cheaper, are unsuitable; they are too porous, and not lasting enough.

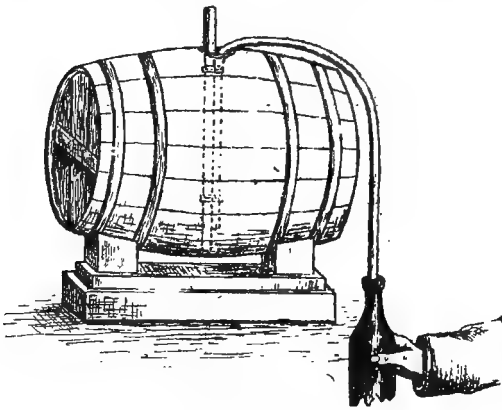

Bottling by Syphon.

A *Syphon* is much more preferable than taps for drawing the wine from the cask and running it into the bottles. The best syphon is a flexible piece of india-rubber tubing about  $\frac{3}{8}$  in. inside diameter. Gas piping answers the purpose very well; two yards, costing 1s. 6d. a yard, are sufficient.

A *Corking Machine* is very convenient. A good substitute is a hand-corking tube, made of boxwood, and costing only 2s. 6d., and a cork-driver, made of a piece of board cut into shape as shown in the illustration.

*Modus Operandi.*—It is supposed that the wine is bright and in good condition for bottling. If it is turbid and dull looking, write for information, or seek the advice of someone who knows how to handle wine. The cask has been allowed to rest on the stand, bung on top, for a week or so, and any sediment that may

have been in it has settled into the bilge of the cask. Remove the wooden shive by hitting the top stave, in which the bung-hole is bored, on each side, alternately. This will start the shive, which will then be easily removed. Better still, bore a hole in the middle of the shive, closing the bung-hole, insert some kind of iron or steel



Cork-driver.



Hand-corking Tube.

lever—a chisel will do—and prise up what is left of the shive. In doing so the circular bung-hole must not be damaged by the chisel, as this will make it difficult to bung it down again when used another time.

The clean bottles having all been arranged around the cask, the operator, after having run water in the india-rubber tubing to cleanse it, places one piece into the cask through the bung-hole, as shown in the illustration, until he feels that the syphon touches the bottom of the cask. He then stands alongside the cask, holds the tube between the thumb and the forefinger, about the same height as the top of the cask, sucks only once, and promptly lowers his end of the tube. If the suction has been properly applied no wine will be spilled, and it will run out at once. Half a glassful is collected, and if not clear and bright it is run into a jug until the clear wine comes out.

The thumb and forefinger compress the end of the tube, which is now placed just inside the neck of the bottle; the pressure is relaxed, and when the wine rises to the middle of the neck of the bottle the rubber tube is pressed again, another bottle is filled, and so on until all the bottles are filled.

Six bottles will be necessary for every gallon of wine in the cask. If the syphoning has been well done there will not be more

than a quart of wine left in the cask. Do not use a tap; wine is almost sure to be spilled unless it is carefully fixed on, and it, moreover, damages the head of the cask, and the cost of cooping will be charged to the consumer.



Method of Bottling.

*Corking.*—Put the corks in a bucket of warm water; this will soften them and make it easier to drive them. If tapered corks are used they are simply fitted in the neck of the filled bottles and they are then driven in with the driver. If the corks are not tapered each one in turn is put in the chamber of the hand-corking tube, which is then placed on the neck of the bottle, and the pusher is then driven down by means of the driver or a wooden mallet.

It is advisable that the bottles be well filled, but sufficient room should be left for the cork, or else the bottle might burst.

## DEFECTS AND DISEASES OF WINE.

Wine, like milk, is susceptible of attack and deterioration from a number of causes. It may be defective or it may be diseased, or, as it often happens, it is both defective and diseased at the same time. The defects are either natural or acquired.

*Natural defects* are those inherent to the commoner and inferior kinds of grapes; to the soil itself, the manures used, to insufficient ripeness, or to the bad manipulation during the process of making.

*Acquired defects or diseases* result from carelessness and tainted casks and vessels. These defects only manifest themselves after fermentation. They constitute the diseases of wines as is generally understood, and each individual one is produced by the presence and the work within the wine of numberless microbes, each kind easily identified from the other by its shape and other characteristics which accompany its growth.

I will rapidly review the more common defects and diseases met with in wines.

*Earthy taste.*—Often inherent to the soil where the grapes were grown. Clayey soils are in this respect more susceptible of imparting an earthy taste to wines than do light loams, which produce wines said to be “clean” to the taste. This defect can be aggravated by long fermentation, especially when the stalks have not been sufficiently separated. Long intervals between rackings also add to it, and for that reason it is advisable to draw the clear wine from over its lees more frequently than would otherwise be done. Occasional light fixings after racking, followed up by another racking, will be found helpful.

*Greenness.*—This defect is caused by an undue proportion of tartaric acid and malic acid in wet seasons, when the grapes have not matured properly. A strong attack of a fungoid disease, bringing about a loss of the leaves of vines, will favour the same defect. Blending in the vat with a proportion of dead ripe and healthy grapes is the best means of correcting this defect.

*Harshness,* caused by excess of tannin. This constituent of wine, which is essential to its good keeping, is generally more perceptible in young wines. Time mellows it down, and it is gradually transformed into gallic acid. Beware of iron coming into contact with such wine, as the chemical reaction which follows would produce ink. If the harshness is excessive, heavy finings by means of gelatine, 3 to 3½ ounces per 100 gallons, will precipitate and remove a portion of the tannin. As such a fining would also remove some of the colouring matter, wines already light in colour should be treated in some other way; for such wine, blending with light, mellow wines, low in tannin, will correct the defect.



*Stalky taste and bitterness.*—This defect is due to another cause altogether to that which produces the disease of “bitterness,” described further on. Some grapes, like malbec, yield a wine showing this defect in a more pronounced manner than others. These grapes treat as indicated under the heading “Earthy taste.”

*Heated taste* is noticeable in wines which have been fermented at too high a temperature.

*Low alcoholic strength*, the produce of grapes having a must of very low specific gravity and poor in sugar. Blending with a stronger wine or light fortification will correct this defect.

*Deficient colour* can be remedied by blending with a dark-coloured wine.

*Dull-coloured Wines.*—Wines thus affected have a kind of leaden colour, and, in the case of red wine, may even appear black. Several causes bring about this trouble, viz.: aeration of wine containing iron; low acidity or excess of tannin of such wines; the action on wine of new casks improperly seasoned; the fermenting of grapes rotting from exposure to wet weather; the fermenting of overripe grapes grown in particularly rich ground; the action of cold on wines. Such wines require energetic treatment to bring back their brilliancy and their normal colour.

The following treatment has been found satisfactory: add to the wine quarter of a pound of common salt per 100 gallons; fine with fresh blood, with clots removed, half-pint to every 100 gallons; this blood mix with a little wine and pour into the wine. By means of the pump, blow air into the cask by continuous pumping for an hour or two; this will cause all the particles of substance in the wine likely to blacken to do so. After this, with the fining rod, stir the wine up thoroughly, so as to cause the blood to thoroughly mix with the wine, then let it rest; the fining will coagulate and settle down into the cask, drawing along in its meshes every particle of impurity which caused the dull colour. Rack after a few days. It is sometimes desirable to run the wine through a filter, not exposed to the action of the air. An addition of two or three ounces of citric acid per 100 gallons of the wine is advisable.

*Putrid Decomposition.*—This defect is rare in Western Australia, where the wines are rich in spirit and in tannin, two elements which impart to the wine vigour and tone. Blending, fortification, and a small addition of tannin remedy this defect to a certain extent.

*Casky Taste.*—Wine run in old casks, left unused for a long time, sometimes contracts an unpleasant, casky taste, which often spoils their sale. The use of pure olive oil, well beaten into the wine, and allowed to float over through the bunghole, has long been recommended. Some have also advised the use of powdered mus-

tard, in doses of 4 to 6 ounces per 100 gallons, to be thoroughly stirred into the wine, which is then allowed to rest for 24 hours; the mustard is first lixiviated with boiling water to guard against the production of essence of mustard when in contact with the wine. Others have had good results from spent coffee ( $1\frac{1}{2}$ lb.), Florence oris powder (1oz. per 100 gallons), to be well stirred into the wine, which rack after four or five days.

#### DISEASE OF WINES.

The defects enumerated above, unlike the diseases mentioned here, are amenable to treatment which does not aim at destroying the injurious micro-organisms, which are the primary cause of the diseases in wines.

Our knowledge of these micro-organisms we owe in the first instance to Pasteur, who at the same time suggested the remedy best calculated to protect the wine against their destructive action. That remedy, in honour of its discoverer, has been called Pasteurisation, and it is carried out in apparatus called Pasteuriser, of which two illustrations are given below.

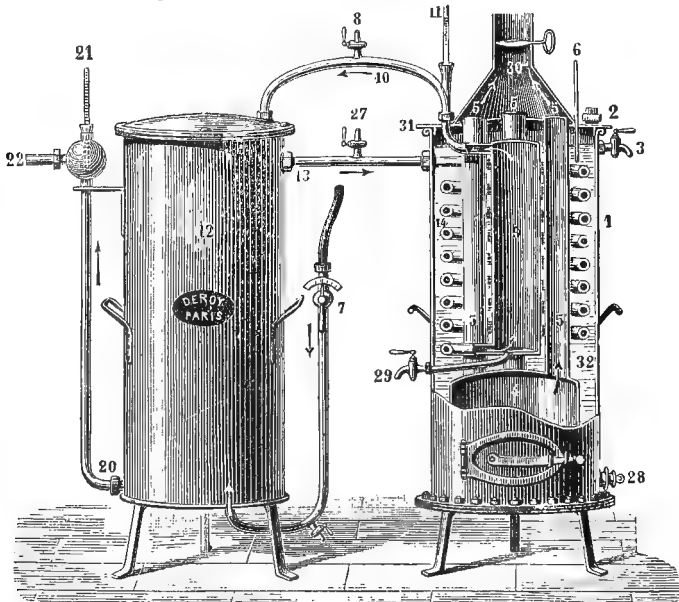

Perrier-Deroy's Pasteuriser.

The apparatus is made of tinned copper. The heat generator is composed of (1) a tubular boiler with a firegrate inside, heating the water jacket; (2) a worm tube immersed in the water, passing

into the central collecting cylinder, surrounded by warm water; (3) a fire grate surmounted by straight tubes communicating with the funnel.

The cooler consists of a cylindrical tank containing the worm, one end of which communicates with the heat generator, the other end serving for the exit of the wine.

The cold wine enters the machine by the tube (7), and, passing through a delivery controlling tap, reaches the bottom of the refrigerator, fills the annular space, forming a kind of worm parallel to the first worm. It then reaches the heat generator (calefactor) through the horizontal tube (13), then descends into the worm of the calefactor, rises through the collecting cylinder (9), intermixing thoroughly, and from there reaches the worm of the refrigerator through the tube (10), where it becomes cooled by contact with the cool wine surrounding the tube.

Thermometers (6) and (11) record the temperature of the water jacket, and that of the wine coming out of the calefactor and out of the refrigerator.

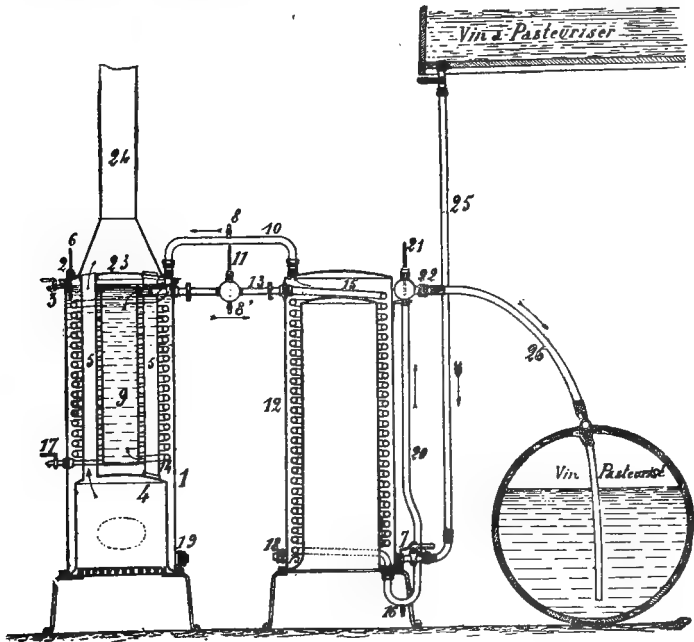

Perrier-Deroy's Pasteuriser.

Before starting, the steam generator is filled with water through the plug (2). When the level of the water reaches the overflow tap (3), the plug (2) is closed and the fire lighted.

Directly the thermometer (6) records 80° C. (176° F.) the top is opened to allow air to escape, and the wine is introduced through the delivery controlling tap (7). When the wine has filled the worm collector and steam generator, it reaches the top, which is closed, and the flow of the liquid, as well as the fire, are regulated in such a way that the thermometer continuously records the required temperature for pasteurisation.

When the operation is finished the fire is put out, and all the parts of the machine are emptied by taps fixed for that purpose.

This apparatus is very simply worked, and can be entrusted to the hands of anyone. Heating takes place rapidly and regularly without alcoholic loss, and with a notable economy of fuel. The various parts of the apparatus may be disconnected when not working.

The second illustration shows another type of the same pasteuriser, constructed by the same makers.

An apparatus designed by Mr. L. Buring and made by an engineering firm in Sydney is said to fulfil all that is required in an efficient pasteuriser; it requires little attention, and the large-size machine will pasteurise about 450 gallons per hour; the smaller, 200 gallons.

It consists in destroying by heat the micro-organisms in the liquid. These micro-organisms, like those we have already considered when dealing with ferments, are made of living albumen (protoplasma), encased in a covering of cellulose. Like the yeast of fermentation, they are provided with spores, which are germs of reproduction more resistant than the protoplasma itself. Heat, when raised to 75° C. (167° F.), coagulates the living albumen, and if that temperature be maintained for a longer period, kills the spores as well.

The acidity, strength, or alkalinity of the liquid these germs are immersed in also influence the degree of heat required to destroy these living germs. Thus, in fresh grape must before fermentation a temperature of 75° to 85° C. or 167° to 185° F. applied for a minute or two destroys all the germs present.

In the resulting wine, after fermentation, however, a temperature of 60° C. (141° F.) applied for a few minutes will achieve the same result; here the action of heat being strengthened by the presence in the wine of both the acids and alcohol. In practice it is found that injurious germs have not the same degree of resistance to heat in sweet, dry red, or dry white wines, and that it is safer

---

Another method, efficacious and easier of application, is sulphur fumes treatment. Instead of sulphur fumes, some chemical substances, such as sulphite, holding sulphur in a loose state of combination, may be substituted with advantage. For instance, sulphite of soda or bisulphite of potash, at the rate of one to two ounces per 100 gallons, simply dropped into the wine, which after a day or so may be stirred a bit and allowed to rest, generally remove in four or five days the objectionable casky taste, whilst neither the colour, the taste, nor the smell remain affected either by the defect or the remedy employed.

to subject the latter to a slightly higher temperature, viz., 66° to 70° C. (151° to 160° F.) for two or three minutes. The temperature at which these micro-organisms perish is called the "death point" of these microbes.

The micro-organisms causing diseases of wines are more microscopic than the yeast plant, and can only be seen under a magnifying power of 600 to 900 diameters. Each kind presents under the microscope well-defined appearance, and each one affects the wine in a different manner. It is not the microbe itself that imparts to the affected wine the defects which shows it to be diseased, but rather the products consequent on its work in the medium in which the microbe lives. It is therefore important that either as a preventive measure or as a curative treatment, if the disease is not too far advanced, timely measures be taken for removing the cause of the trouble. As demonstrated by Pasteur, heat under proper control does this without impairing the quality of the wine.

In a substance like milk, on the other hand, which is at the same time alkaline and fatty, the temperature has to be raised to about 110° C. or ever higher to sterilise the liquid, which has to be brought to the boil.

When Pasteur was carrying out his experiments on the heating of wines, a commission was appointed to taste the wines so treated, and the members reported as follows:—

"It is impossible to deny that the result of heating the wines examined shows a decided advantage over the unpasteurised wines. Its effect is preventive of disease, it destroys the germs; the presence of which is the cause of the various sickness in wine—without hindering the development of their quality. All the pasteurised wines are good; they have not changed in taste or colour; their condition is perfect. We have come to the conclusion that the process is of practical value, and especially when applied to large quantities of wine."

When pasteurising wine, or for the matter of that, any kind of liquid, it is essential that everything which comes in contact with it must be sterilised, otherwise infection may again take place, and the whole work is in vain.

Unless sufficient tannin is present, it may assume a light bluish tint after heating, and if it is intended to blend two or more wines, it is advisable to pasteurise before than after the blending. It is needless to say that an unpasteurised wine should not be used for filling up casks of pasteurised wines.

#### DISEASE GERMS.

The micro-organisms, which are the active agents of diseases of wine, have been divided by Pasteur in two classes:—

- (1) Those which take the oxygen they need for their respiration from the air itself, called "aerobic" ferments.

- (2) Those which take their oxygen from substances rich in oxygen, and not from the air itself—"anaerobic" ferments.

To the first group belong the diseases which cause Acetic fermentation, Flowers of wine, and the disease the French call *Casse*, or the breaking of the wine.

To the second belong Mannitic or Lactic fermentation, Bitter, Grease, and *Pousse*, or *Tourne*.

The yeast germs are "anaerobic," in so far as they obtain their oxygen from the sugar they feed upon, although an occasional infusion of oxygen from outside, as occurs when the must is aerated, adds fresh life to them. In this much they behave like "anaerobic" ferments.

The above classification, although not absolutely correct, is however accepted by scientists as being in the main correct.

*Flowers of Wine* are not in themselves very injurious to wines. They are often seen like a white greasy film floating on the surface in casks containing light wines and which have not been kept scrupulously clean.

They are when thus seen, an agglomeration of microscopic fungi, very pretty when seen under the microscope, known by botan-

ists as *Saccharomyces* or *Mycoderma vini*. The cells are elliptic in shape, and multiply by germination or budding. They are always found on the surface, as they require air for their existence, whilst they consume the alcohol of the wine, turning it into carbonic acid gas and water. They also destroy the aldehydes and ethers of the wine which contribute to form the bouquet.

By weakening the wine of its spirit, they pave the way to the invasion of that other

more dangerous mycoderm which causes acetification. Unlike the latter, they never sink into the wine. When the flowers of wine are allowed to thrive unchecked they impart to the wine an unpleasant mouldy taste.

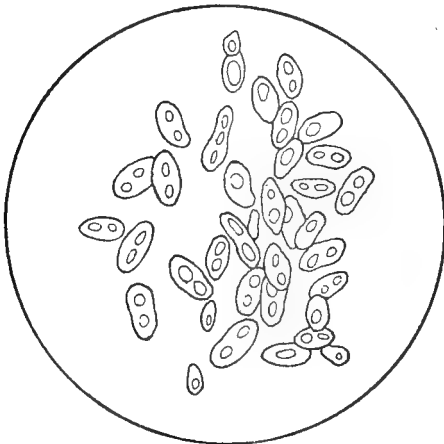

Flowers of Wine (*Mycoderma vini*).  $\frac{700}{1}$

They are easy to keep out if casks are continuously maintained full, in order to exclude air. Where a thin light veil caused by this fungus occurs, a good plan for getting rid of it is to insert into the bung-hole to a depth of a few inches a tin tube, the upper end of which closes with the thumb; that tube will penetrate the floating layer without carrying any of it downwards and without disturbing the wine. Fit a funnel at the upper end of the tube and pour sufficient strong wine into the cask to fill the ullage. The veil of microbes will float to the surface, and by pouring more wine will run out through the bung-hole. The ullage should be frequently filled.

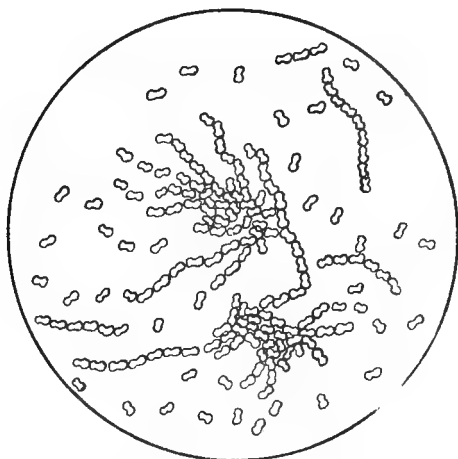

*Mycoderma or Diplococcus acti*  $\frac{700}{7}$

If the wine has already contracted a mouldy taste, it should be racked into a sulphured cask after the fungus has been removed as explained. Add a gallon of strong spirit or a few gallons of a stronger wine, per 100 gallons, fine and rack again.

*Acetification* is one of the most common diseases of wine and also one of the most troublesome. Like the flowers of wine, it consumes the alcohol of wine,

when exposed to air. Under these circumstances it transforms the alcohol into acetic acid and water, and is shown by the following chemical equation:—

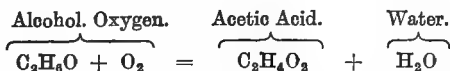

The disease generally only attacks wine that has been neglected and left in ullaged casks. It shows as a film, wrinkled and velvety on the surface. After a time masses of viscous matter in the wine surround that film and cause some portion of it to sink. When looked at under a high-power microscope the germs show as oblong cells disposed rod fashion. These cells multiply very rapidly by a process of segmentation, or pinching in the centre. The disease is easier to guard against than to counteract. As the alteration starts from the surface it is sometimes possible when the trouble has just

started to draw off the lower portion of the wine still sound in the cask, and separate it from the altered wine at the top.

If the wine is only slightly pricked it may to some extent be corrected by using per quarter-cask:

- 1° carbonate of lime (powdered marble), or preferably, carbonate of magnesia, 2 to 4 oz.
- Neutral tartrate of potash (1 gramme) 15 grains.
- Spirit of wine, 1 quart.

Shake and stir well, and after a couple of days fine with gelatine or isinglass, and if necessary add a little tannin to assist the fining. When clear, rack in heavily-sulphured and clean cask, which must always be kept quite full.

Another method consists in mixing per 100 gals. of the slightly pricked wine, 2 to 4 oz. of neutral tartrate of potash, which is dissolved in a little warm water, then stirred into the cask, which is next fined and racked.

Other methods are used for correcting sour wines, but as they result in leaving into it substances which would injuriously affect the consumer, they are rightly considered illegitimate, and are not used in respectable cellars. Sour wine can more profitably be turned into vinegar and sold as such than faked up into unwholesome drugs.

When the wine is lightly pricked, however, it may, with advantage, be pasteurised, and then blended with a heavy wine low in acids.

*Casse*.—This disease has been referred to when treating of the manufacture of white wine (p. 461). Of *casse* or break there are two kinds, the "blue" and the "brown." The "blue" *casse* is characterised by the separation of the blue colouring matter of the grape juice, of which two others exist, viz., the red and the yellow. This particular kind of "break" can be stopped, or, better, prevented by the addition of tartaric acid to the must in doses at the rate of 8oz. to 1½lbs. per 100 gallons. The "brown" break is caused by an oxidising diastase, which produces a kind of black matter called "oxydase" through feeding on the albuminoid matters in the wine.

As this trouble is caused by an organised ferment, nothing short of its suppression will bring about a cure. This is effected by means of pasteurisation or sterilisation by heat or by the use of sulphurous acid.

Red wines thus affected appear sound whilst in the casks, when air does not get at it, but without warning and almost suddenly, when drawn or bottled, they turn black and show a brownish deposit.



The taste and chemical constituents of the wine are not very perceptibly altered, but the wines become unsightly. When looked at through clear glass, either the white or red wine shows a scud, and from brilliant and limped when fresh drawn from the cask it becomes dull, shows an iridescence on the surface, and the colouring matter gradually oxidising throws a brown-coloured sediment. The wine sometimes has a leathery smell, and has a slightly acidulate and bitterish taste.

The oxidising diastase feeding on the albuminoid substances in the wine is more commonly met with in wines produced from grapes grown on rich alluvial soils. Tannin, which coagulates albumen, is generally deficient in such wines, and a slight addition of this substance is often attended with good results. Sulphur, however, is in every case beneficial, and may be used at the rate of 6 to 30 grammes of sulphurous acid per 100 gallons, or its equivalent, three to 15 grammes, of sulphur ( $\frac{1}{8}$ oz. to  $\frac{1}{2}$ oz.) or 12 to 60 grammes ( $\frac{1}{2}$ oz. to 2ozs.) of bisulphite of potash.

Amongst the diseases caused by anaerobic microbes—

*Mannitic Fermentation* is one of the most troublesome in hot climates. The disease is caused by short, motionless, rod-like microbes, which congregate in groups and are often found associated with germs of other diseases. Two requirements are necessary for their development—the presence of unfermented sugar in the wine, and a higher temperature than is suitable for the yeast ferment, viz., 35°-40° C. (95°-104° F.). The disease generally starts in the fermenting vat whenever the temperature is allowed to go up too high.

As a result of the presence of this microbe in large numbers, the unfermented sugar is transformed into another kind of sugar, called mannite, and into lactic acid, the result being a sour-sweet wine.

The remedies are low temperature fermentation, or early fortification with spirits of wine, or pasteurisation.

The cream of tartar is not decomposed in mannitic wine, as is the case in wines affected with the *tourne* disease.

*Tourne (Turning) and "Pousse" (Pushing) Diseases.*—These diseases attack any kind of wine of low alcoholic strength. In appearance they are very much alike, and show like very minute filaments, grouped together in mucous bundles.

The *pousse* microbes attack the tartaric acid of the wine, which it transforms into acetic and propionic acids, whilst in the *Tourne* the tartaric acid is turned into carbonic and lactic acids. The diseased wine tastes flat, its colour is precipitated. In the *Pousse* gases are generated, which, should the cask be tightly bunged, may

cause the head to bulge out. The carbonic acid bubbles appear on the surface as fine persistent bubbles. Under the microscope the ferment of the *Tourne* shows in the form of long batonnets or rods, without movement. The remedy prescribed is to add cream of tartar to the wine and pasteurise it or fortify it up to 14 or 15 per cent. of alcohol (30-32 per cent. proof).

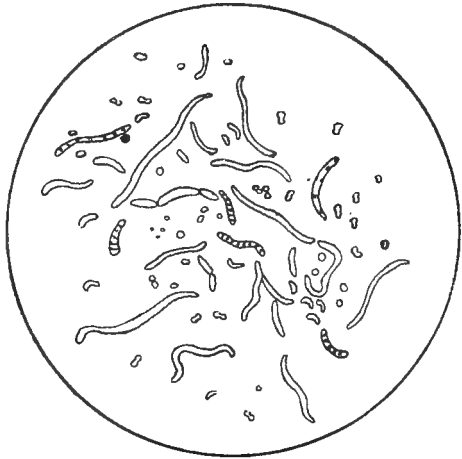

The Pousse Ferment,  $\frac{1000}{1}$

*Ropiness*, also called "grease disease," is peculiar to white wines, deficient in tannin. Such wines are turbid in look, flat, and viscous in

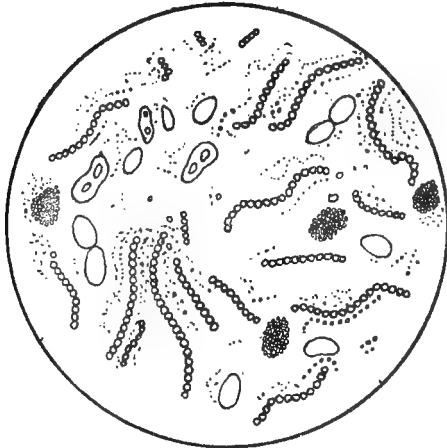

Grease or Ropy Ferment,  $\frac{700}{1}$

appearance. The active agent of the disease is a microbe which, at first sight, is not unlike the *micoderma aceti*. It is, however, encased in a sheath of viscous matter which gives to wine an oily appearance. White wines light in alcohol—under 12 per cent. or 26 per cent. proof—and produced from grapes grown on rich alluvial flats, or more or less decomposed and rich in albuminoid matters, are more susceptible to the disease. The remedy is the elimination of these

albuminoid matters, which can be effected by an addition of tannin varying from one-eighth to one-sixth ounce per 100 gallons; aeration and stirring violently to break up the viscosity of the microbes, slight fortification to bring the strength of the wine to 12 per cent.

or more. Pasteurisation will cure the disease in one act. In either case fining and racking are indicated.

*Bitterness* is caused by a small, threadlike microbe which, when dying, is encased in the colouring matter of red wines at the beginning of the sickness. The wine develops a peculiar disagreeable smell, at the same time loses the freshness of its colour and appears more brown. The taste also becomes uneven, flat, sweetish, and is transformed into a bitter taste by degrees. Following the progress of the sickness the colouring matter is entirely lost, and the wine in the end becomes undrinkable.

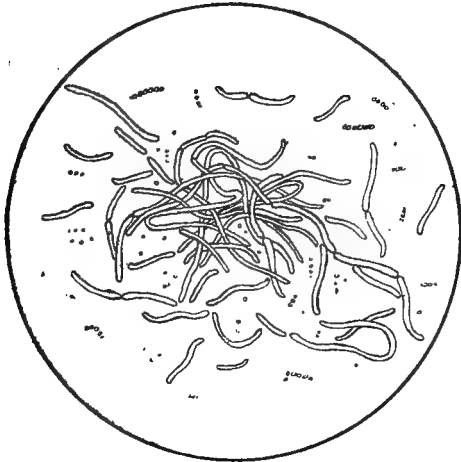

Bitterness Ferment.

Not only in the cask, but in the bottle, may the wine become bitter.

Several means have been suggested as a cure:—

- (1.) A new fermentation with fresh must; this means only spoiling good must.
- (2.) Racking in strongly sulphured casks only checks the progress of the disease.
- (3.) Pasteurising checks it, but, unless carefully done, often spoils the original taste of the wine.
- (4.) Fortifying up to 12 per cent. (26 per cent. proof), and a little addition of tartaric acid, will hide the bitter taste. If the disease has gone too far, it is impossible to overcome the bitter taste.

When slightly attacked the use of oxidising substances, such as permanganate of potash, in very slight doses, after previous fortification up to about 14 per cent., gives very rapid result. Aeration is also good. After this, blending with wines of deep colour, and rich in tannin, will restore to the affected wine its desired equilibrium. If such a wine is not at hand, add 1 to 2 oz. of tannic acid per 100 gallons of the liquid. Tannin is soluble in the must, but it is preferable to dissolve it in a little alcohol before using; say 1lb. of tannic acid in one gallon of spirit of wine. One pint of this

solution will contain 2ozs. of tannin. Mix first with about 10 gallons of must or of wine, and add these 10 gallons to the other 90 and whisk briskly.

### UNFERMENTED GRAPE-JUICE.

Inquiries are often made concerning the proper method of making "unfermented wine." Such an article is, it appears, in demand for sacramental purposes, and a ready sale also exists for using it as a cooling drink.

"Unfermented wine" is, it is only fair to state at the outset, only a snare and a delusion. The word "wine" implies alcoholic fermentation, and so soon as any kind of fruit juice has its sugar transformed into alcohol, through the agency of the living agents of fermentation, it becomes a "wine."

A glance at an analysis of freshly-pressed grape-must will satisfy anyone that no spirit nor glycerine—both residues of alcoholic fermentation—are present. The analysis will also indicate the presence of nourishing and wholesome constituents, which are combined and grouped in a form which is at the same time palatable and wholesome.

The following table shows the several components of fresh grape-juice prior to fermentation:—

Water	.. .. .	80 to 85	parts
Grape sugar (dextrose and lævulose)..	15 ,, 28	,,	,,
Free acids (tartaric, tannic) .. ..	0.1 ,, 1	,,	,,
Salts of organic acids (tartrates,, malates, citrate of potassium, calcium, etc.)..	0.4 ,, 0.8	,,	,,
Salts of mineral acids, sulphates, nitrates, phosphates, silicates of potassium, cal- cium, magnesium, iron .. ..	0.3 ,, 0.5	,,	,,
Albuminoid matters .. .. .	0.3 ,, 1	,,	,,

Any unfermented wine, therefore, showing substances not mentioned in this analysis must have been tampered with and ceases to be pure grape-juice.

### WHY GRAPE-JUICE FERMENTS.

Side by side with the grape-juice, nature has placed active living agents which, when they gain access to that juice, break up and disorganise its several compounds into substances widely different in nature, composition, and properties. These living agents are of microscopic size, and although more numerous on the waxy bloom which covers the skin of the fruit, they also float about in the air we breathe, and are present on the surface of all manner

of vessels and appliances which may be used during the handling of the grape or other juices. These micro-organisms belong to numerous species, and are classified as moulds, yeasts, and bacteria. They differ as regards their shape, their habits, and the resulting produce of their activities. Besides these living agents of decomposition of the juices of fruit, there are present viscous, albuminoid substances which cause a certain amount of turbidity in the liquid and make it unattractive to the sight.

Those two factors, viz., micro-organisms and viscous albuminoid substances, are the two elements which the unfermented grape-juice preserver has to contend with, and in order to purge the liquid of them, two ways present themselves—one chemical and one physical. The chemical methods consist in paralysing the microscopic cells of the agents of fermentation by means of antiseptic substances. This method is prohibited wherever a Pure Food Act is enforced, and moreover, on hygienic grounds it is strongly to be deprecated, for the reason that such toxic substances which silence and paralyse the living cells of organisms in the sweet juice, on the other hand also happen to injuriously affect those other micro-organisms which accompany and foster digestion. Their use is to be deprecated, and should be prohibited by law.

The physical methods are, on the other hand, safe, and yield results which are quite satisfactory. These are purely mechanical, such as filtering, or both mechanical and biological, such as those methods in which heat, cold, or electricity play the leading part. Of these, heat is, up to the present, both the cheapest and the most reliable.

The germs figured in the chapter on "Ferments and on Diseases of Wine" consist of translucent gelatinous cells which at even a moderate temperature coagulate and perish. The temperature at which these micro-organisms perish is called "the death point" of these microbes. This point is several degrees lower in slightly acid liquids, such as grape or other fruit-juice, than it is in neutral liquids. Time is also a factor which in a measure influences this death point. For instance, a micro-organism which would only perish if heated for half an hour at, say, 60deg. C. (140deg. F.) would probably survive the treatment if the period of heating was only a quarter of an hour. Then again, micro-organisms occur in two states: an active or growing state, consisting of a fragment of protoplasm, encased in a cellulose covering, and a resting or spore state, the spores being minute nuclei embedded into the body of the micro-organism and endowed with greater resistant properties. This being so, a degree of heat which would coagulate and kill the micro-organism in its gellified or growing state would probably only cause passing discomfort to the more hardened resting spores. As a rule, it requires about 5deg. C. (9deg. F.) additional above the death

point of the growing micro-organism to kill the same organism in its resting state. In practice it is found that grape-must is sterilised by heating up to 65deg. to 75deg. C. (149deg. to 167deg. F.). It is essential not to raise the temperature too high, so as not to affect the delicacy of taste or colour of the liquid operated upon, and for that purpose it is essential not to exceed 85deg. C. (185deg. F.).

Whilst it is known that germs of fermentation and of other decomposition are destroyed at a comparatively low temperature when immersed in an organic liquid, these same germs, when desiccated, can tolerate a much higher temperature with impunity. It is important to bear in mind this fact when bottling the sterilised liquid, as any germs which may be resting on the dry neck of the bottle or on the cork would escape destruction, and would later on start a fresh growth and spoil the liquid. In order to guard against this, both bottles and corks must be boiled just before using. This is done for at least half an hour, and when handling care should be taken not to touch the bottles with the hands high up the neck lest some germs present on the fingers should be conveyed to the mouth of the bottles and thence into the liquid.

#### PLANT REQUIRED.

On a fairly large scale a plant proportionate with the output of unfermented juice would be required. Such a plant would include a steam boiler, a steriliser, or Pasteuriser, to sterilise the juice; a filter press, to separate the clear juice from the viscous pulpy tissue floating in it; a hot-water dip, such as are used at canning works, for sterilising the bottles. On a smaller scale a less elaborate plant can be made to answer. An open copper for heating the must and boiling both bottles and corks, a filter, and a bottle steriliser may be made to answer the desired purpose.

#### MODUS OPERANDI.

The grapes having been crushed, the juice is run into a vat, where it is allowed to deposit its slime. In hot weather, ice or an attemperator may be used to cool it down and prevent it fermenting for a few hours. From this settling vat the partly clarified must is taken to the open copper (a double boiler or steam jacketed boiler is the best) and heated up to 85deg. C. (185deg. F.) for half an hour, and skimmed and then run through a cooler into fresh settling receptacles, properly sterilised. That temperature will coagulate the albumen and other flocculent matters, and for that purpose the temperature should never exceed 190deg. F., at which some of the albumen will re-dissolve, nor less than 175deg. F., at which it will not coagulate. A thermometer should be used, if not,

heat the juice till it steams, but it must not boil. Steamed casks, closed by means of sterilised bungs, will do. Here much of the albuminoid and viscous matters in the must, which will have been coagulated during the first heating process, are deposited; it will

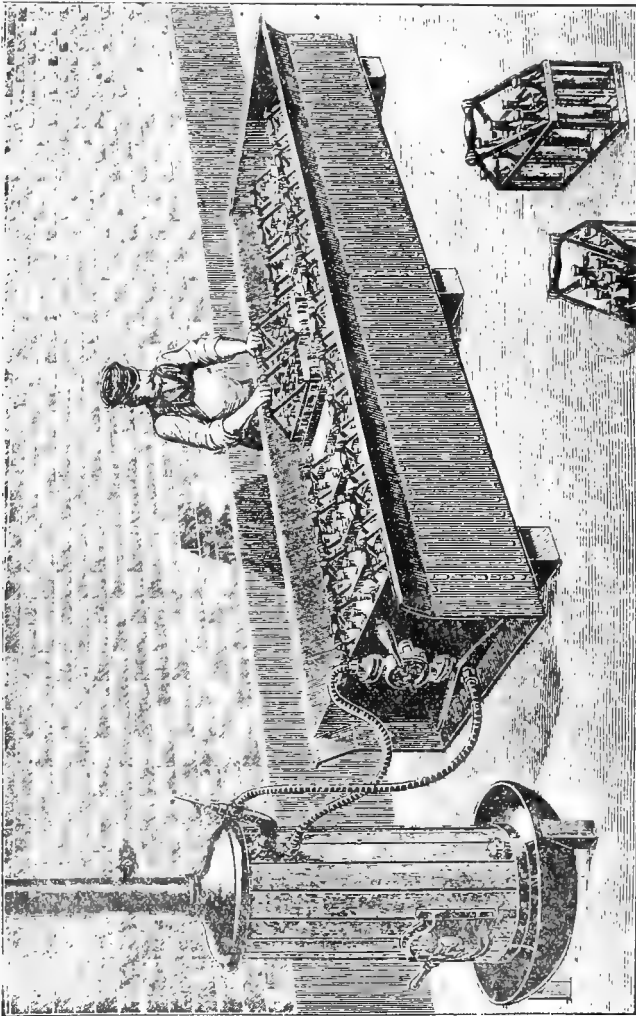

Gasquet's Bottle Pasteuriser.

take 24 hours to clear. This renders the operation of filtering much easier. After this the must may be filtered through a conical flannel bag or any suitable filter and run into sterilised bottles, which are then securely corked with well-sterilised corks. The corking is

sometimes done after the final heating and whilst the bottles are still hot. These bottles are set to stand in a hot water trough, and over a thin board if the fire is direct, and the temperature gradually brought up to 80deg. C. (175deg. F.), at which temperature they are maintained for quarter of an hour. A thermometer placed in one of the bottles indicates the exact degree of heat. It is essential, in order to sterilise the must, that that temperature be reached but not exceeded, as a higher degree of heat at the final heating would coagulate a fresh lot of albuminoid matter, which would cause their precipitation and make the liquid turbid.

It is advisable to secure the corks by means of strings during this second sterilisation, in order to prevent them being blown up. When this is done the contents of the bottles will keep for almost an indefinite period, unless some threads of moulds penetrate the corks and contaminate the liquid. To guard against this, it is a good practice to dip the neck of the filled bottles into a 2 per cent. solution of sulphate of copper (3ozs. to 4ozs. blue stone in 1 gal. water), and when dry either cover with bottling wax or a capsule. Should signs of turbidity show after a few days, repeat the sterilising process a third time.

Grape-juice thus prepared will, with the exception of a few tinted juice grapes, be white or amber colour, and be possessed with the particular aroma of the grape used in its manufacture.

When filled, lay the bottles in rows on the side, and note any which may be leaking at the cork. These put by for more immediate use; the others are slightly dipped at the neck in bottling wax, which may be bought at cork merchants or at wholesale druggists for a few pence per lb. Different colours, such as red, green, blue or white may be used for different wines. Care should be used, in melting, to keep the wax continually stirred, to prevent it burning and assuming the appearance of a gritty deposit.

Grape juice thus bottled may be kept sound for years. It will greatly improve by keeping a few months before it is used.

#### VINEGAR FROM WINE AND FROM CIDER.

When sweet fruit juice is pressed and left exposed to the air a change rapidly takes place, first into *alcoholic*, subsequently into *acetic* fermentation, and finally into *putrid* fermentation, which would, of course, spoil the liquor for any purpose.

The art of wine and cider making is directed to the prevention of acetic fermentation; that of the vinegar manufacturer aims at converting into a marketable commodity the product of grapes unsuitable for wine making, and of apples for which no market offers.

All methods of vinegar making are based on the oxidation of the spirit of alcoholic liquids in the presence of air. This kind of



slow combustion takes away hydrogen from the alcohol to form water, and oxidises the compound. The aim of the vinegar manufacturer should therefore be to obtain this oxidation under the most advantageous conditions of rapidity, economy, and quality.

In previous chapters place has been given to the consideration of the manufacture of sound wine; a few notes on the conversion of apples and pears, not intended for stock feed, into cider and perry will explain the transformation of otherwise sound fruit into a wholesome beverage or ultimately into vinegar largely used as a condiment or for pickling purposes.

#### CIDER AND PERRY.

The best cider is made from three sorts of apples: the "sweet," the "sweet-bitter," and the "sharp" varieties. The first is rich in sugar and will give alcoholic strength; the second has an excess of tannin, which helps the cider to clarify, without it it will be thick and ropy and won't keep; the third class, containing a larger amount of malic and of tartaric acids, will assist the alcoholic ferment and check the invasion of dangerous germs during the process of fermentation; moreover, by its action on the alcohol produced, ethers will be formed which impart to the cider a characteristic taste and smell known as "bouquet." Few apples contain these three essential constituents in well balanced proportions, hence the mixing of several varieties of apples by the Devonshire and by the Normandy cider makers.

The varieties of cider apples grown where cider is extensively made belong to the same species as those cultivated for dessert or for cooking, the only difference being the smaller size of the fruits and the special characteristics referred to.

To grow apples for the sole purpose of conversion into cider has not yet been successfully attempted in Australia. A few firms are putting on the market a very commendable article, but the bulk of the cider manufactured by individual growers is of such a class that it is unmarketable as a beverage but is capable of being transformed into a first class vinegar.

For this purpose, windfalls and rejects, which unfortunately represent an important proportion of the apple crop, would find a ready sale at distilleries and vinegar factories.

*Yield of Cider per ton of Apples.*—Theoretically, apples contain 50 to 75 per cent. of juice, or an average of 70 per cent., but ordinary methods of pressing does not account for more than about 50 per cent., as after a certain point has been reached the cost of extraction appears to be greater than the value of the juice obtained. In practice, it takes 20 to 25 lbs. of apples to make one gallon of cider; in other words, one ton of apples yields about 100 gallons of cider, which allows for a loss during fermentation at the rate of 10 per cent., the balance being left unpressed in the

pressed pulp. By adopting the diffusion process of extraction a greater percentage should be obtained.

The average specific gravity of the juice of sound, ripe apples is 1.060 (8.2 Baumé) or 15 per cent. sugar with extracts added. This on complete fermentation gives about 9 per cent. alcohol by volume (16.75 proof spirit). In culls the specific gravity would be lower and the resulting cider shows about 6 per cent. absolute alcohol by volume (13° proof).

### *Manufacture of Cider and Perry.*

The apples or pears to be crushed must be sound. If they are not clean, the hose may be put on them, provided the water is allowed to drain quickly; if this can be avoided so much the better, as water washes off the bloom which carries the yeast. Decayed

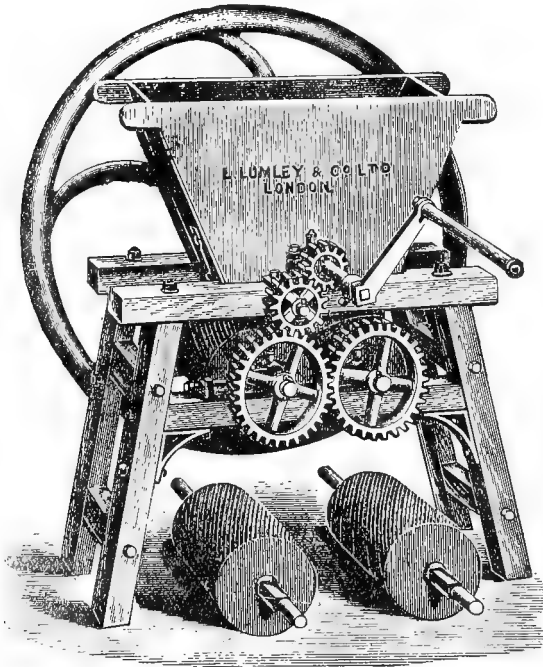

Improved Apple Mill and Grater.

apples will cause the cider to be flat, of bad flavour, and of bad keeping. Then reduce them to a pulp. For this purpose a mill, something like a turnip pulper, in which the fruit after being broken up by toothed rollers is passed through fluted rollers, is very convenient.

For convenient pressing this pulp or pomace which would squeeze out between the battens of the press, is generally packed in flat bags made of tough fibrous material like grass, horsehair, etc. For a small orchard it might be packed in some flat bags made of coarse hessian, like the stuff used for onion bags, and these should be boiled and rinsed in clean water to remove any unpleasant taste. Fold the open end back and pile these half-filled bags one on top of the other on the tray of the press. If bags are used it is not neces-

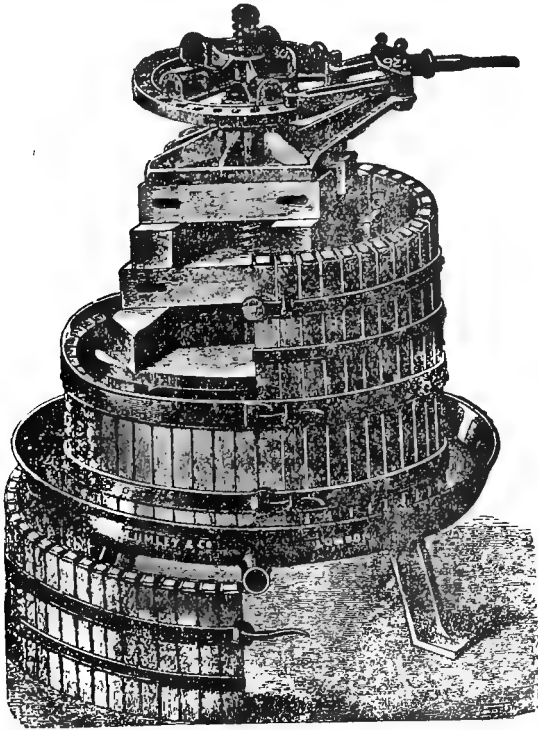

Cider Press.

sary to have the battened cage around. When the juice has all been pressed it is run into clean and sound casks or a small vat—casks with heads taken off would do.

When table kinds are used, they are often deficient in tannin and in fruit acids; this deficiency is made up by addition to the juice: tannin,  $\frac{1}{2}$  to 1oz.; and tartaric acid, 2 to 4ozs. per 100 gallons.

The juice is allowed to rest in the open vat for a few hours, when slimes will settle to the bottom and a light cap of scum will

rise and float. The liquid between is then more or less clear and can be syphoned into clean and sulphured casks filled up to within a few inches of the bung-hole.

Here the gradual conversion of the sugar contents into alcohol proceeds. If it is intended to distil the product of fermentation or turn it into vinegar, the juice should be allowed to ferment out completely, as the presence of sugar means loss of alcohol, and it should be avoided if it is intended to convert it into apple-brandy or into vinegar.

This stage having been reached, experienced cider makers are able to regulate the fermentation and check it at the right stage by attention to temperature, by frequent racking, filtering, and by sulphuring the casks, or by pasteurisation. All these processes have been dealt with in connection with wine making. For making into vinegar, sulphuring should be lightly used, as it is detrimental to the growth of the acetifying mycoderm germ. As soon as it is fairly clear it is racked into fresh casks to draw it from over the lees of fermentation.

If intended for use as cider, some prefer a sweet and sparkling cider to a dry and as is sometimes called a "hard" cider, which is to the cider drinker what claret is to the wine drinker.

#### *Bottling Cider.*

The best time for bottling is when fermentation is neither too active nor too feeble, so that the cider will clear and sparkle, and at the same time will not leave a thick deposit in the bottle. This is when the specific gravity comes down to about 1015 or 2° Baumé, indicating the presence of 3½ to 4 per cent. sugar still left in the liquid. If the specific gravity is below 1010 (1½° Baume, 2½ per cent. sugar) add 20lbs. sugar to 100 gallons of the cider and bottle.

For sparkling cider strong champagne bottles should be used, and the corks tied with iron wire. The bottles should not be filled completely, but a space left between the liquid and the cork, and placed upright in a cool cellar. It is not necessary to lay the bottles flat immediately after they have been filled, as that would tend to break them by the pressure of the gas; they should not be laid until a few weeks later, and then upon wooden laths or in dry sand. If they are left upright too long, some of the carbonic acid escapes and the cider not so sparkling. For cider less foamy than the former, bottling must be delayed until the fermentation is more advanced, when the cider is less sweet. The cider, which is still relatively sweet, then contains enough sugar to give an agreeable sparkling and long-keeping drink. The black mineral water bottles and beer bottles are quite strong enough, and the corks should be tide with twine, the bottles being left upright a few days. For still and dry cider any

bottles can be used, because there is less carbonic acid than in the two former cases. They should be laid flat when filled, in order to retain the carbonic acid.

#### *Acetification of Cider.*

The apple or the pear juice having been transformed into cider or into perry it can be used as such, or a step further may be gone and it may be manufactured into vinegar. It is essential for this purpose that the liquid becomes clear and free of the carbonic acid gas with which it was charged at the close of its alcoholic fermentation, as these conditions would interfere with the spread over the surface of the mycodermic veil which forms during the process of acetification.

#### VINEGAR.

The name is given to alcoholic liquids which have undergone acetific fermentation—wine, lees, \*cider, perry, beer, in fact any weak alcoholic solution may be transformed into vinegar by the action of the *Mycoderma aceti* organism. Wood vinegar is an exception, being the product of the distillation of wood when subjected to a high temperature.

The floating veil of *Mycoderma aceti* works normally in liquids which already contain acetic acid, otherwise under the influence of air and a suitable temperature it is replaced or interfered with by another form, viz., *Mycoderma vini*, illustrated on page 490, under the name of "Flowers of Wine," and which weakens the alcoholic mixture by the direct transformation of alcohol into water and carbonic acid gas, a process which accounts for a weaker vinegar being produced. For this reason, wine or cider used in the manufacture of vinegar should receive as a starter a certain quantity of that product.

As a condiment wine or cider vinegar, in addition to acetic acid contain organic and inorganic salts, ethers which give the bouquet, glycerine, in reality, all the elements which constitute the original liquid. Cheaper grades of vinegar are also made with diluted cheap spirits; these possess none of the hygienic constituents of the first-named kinds and are more or less injurious to weak digestions.

Pasteur discovered that under the action of *Mycoderma aceti*, which is classed among the group of aerobian ferments, i.e., requiring the oxygen of the air to exist, alcohol is oxidised and acetic acid and water results. A certain amount of heat is generated during that transformation. The micro-organism (mother of vinegar) forms the veil floating on the surface and does its best work at temperatures ranging between 67deg. and 87deg. F. (20-31deg. C.), outside these limits the ferments suffer and eventually cease to work.

In order to guard against the invasion of other germs, it is desirable to sow the right kind, and unless good vinegar is at hand a culture must be made. For that purpose take a saucer or a shallow vessel, in which place a weak wine a little acetified with good vinegar and place in a warm place where it is not disturbed; when a veil appears place on the surface of the wine in an ullaged cask.

This is the old "Orleans" method. The only drawback is that it is slow, taking about two months before good vinegar is made. For household use, when consumption is moderate, it does not matter. Take a cask, or if a quantity is to be handled several casks, bore a hole  $\frac{3}{4}$  up the heads and opposite, cover these holes with mosquito netting or with cheese cloth, to keep out vinegar flies and insects. The hoops must be painted to prevent the vapours of acetic acid attacking them. In front, between the wooden tap and the air hole, a bent glass tube is tightly fixed in a cork to show the level of the liquid.

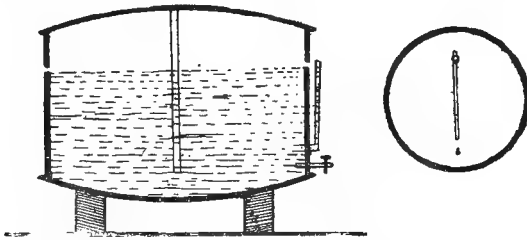

Diagram of a Vinegar mother cask (Orleans method).

The cask must be securely fixed to prevent shaking, which would break the veil and interfere with the growth of the ferment.

For the same reason a glass tube is put into the cask, through the bung-hole, through which the wine is periodically poured to keep up the same level. To start operations, reduce the strength of the wine to about 10deg. to 12deg. proof, add one-third good vinegar, bringing the level up to half an inch of each air hole. At the end of four to six weeks, vinegar may be drawn and an equivalent quantity of weak wine added.

During the process of acetification there is an evaporation of about 10 per cent.

*The German Method* is quicker than the Orleans method and is continuous. The loss by evaporation of the alcoholic liquid during the process of acetification is greater than in the case of the Orleans method and the ethers which give the bouquet which are developed in the course of the first method are less noticeable in this method.

The apparatus consists of an elongated cylindrical wooden cask or generator. The top head consists of a lid provided with a large hole through which the liquid is fed, and another one with a piece

of piping for the escape of air. Six inches below that lid is a false head bored with a number of conical holes through which are passed pieces of string 6 inches long, with knots which keep them hanging, and at the same time stop the holes incompletely. At the bottom is a wooden tap or one well made of tinned metal. Twelve inches above is a false bottom. Round the base of the cask, between two bottoms are vent holes bored slanting from outside downwards.

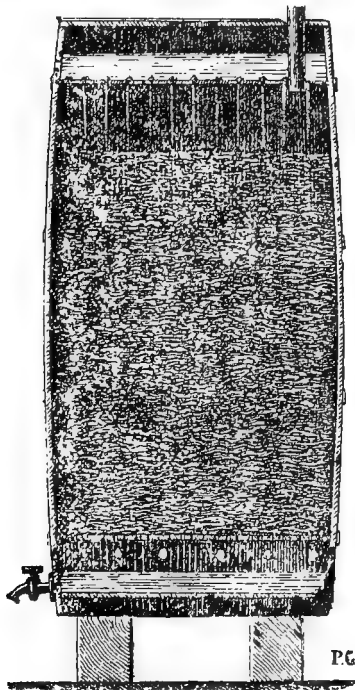

Vinegar generator (German method).

The space between the false bottom and the false head is filled with beechwood shavings to the level of the lower ends of the strings. They will last for a great number of years. These shavings are soaked in vinegar, which helps the transformation of alcohol into acetic acid.

The operation is simply conducted: the alcoholic liquid to be treated is pumped into a receiver at a higher level than the top of the vinegar generator. The liquid is allowed to run as a fine stream which trickles down slowly over the germ-laden beechwood shavings which offer a very large surface to the oxidising action of air. It acetifies whilst it trickles down slowly through these shavings and falls into the bottom part of the cask whence it is drawn and casked, or if not completely acetified, it is run through again. The air travels

in an opposite direction, entering at the holes at the bottom, it escapes by the tube fixed on the top falsehead. The temperature should register 67 to 87 deg. F. as in the Orleans process.

The small destructive animal, called the vinegar eel, which sometimes infect the mother casks in the Orleans method, do not gain a footing here.

Commercial vinegar contains from 4 to 6 per cent. of acetic acid.

Ex.: Given vinegar at 5.90 acetic acid, how much water to add to break down to 5 per cent?

$$\frac{100 \times 5.90}{5} = \frac{590}{5} = 118 \text{ or } 18 \text{ parts of water.}$$

If vinegar keeps dull after it is made and shows signs of malady, which destroy the inherent acetic acid and the bouquet, pasteurising will remove the trouble. The apparatus should be well tinned to guard against corrosion.

### INFERTILE GRAPE VINES.

When the vines have set their fruit, any that are sterile or fail to carry a crop commensurate with their vigour more forcibly attract attention.

By setting of the fruit is understood the proper fertilisation of the ovary. This occurs in the spring of the year, and wherever grape vines are grown under artificial conditions of shelter, etc., it proves an anxious time to all cultivators of the vine.

In Western Australia, where the open air climatic conditions in the spring are in every respect favourable to the proper fertilisation of the ovaries, grapes set without trouble and with great perfection. Yet individual exceptions are occasionally met with, which are subject to the following conditions:—

- I. Climatic conditions which cause non-setting.
- II. Structural or constitutional defects.

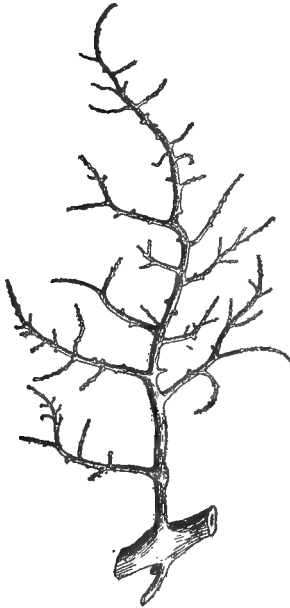

FIG. 1.—Bunch of grapes showing complete non-setting.

In the first instance it is important to understand how the grape vine blossoms set.



FIG. 2.—Normal buds before fertilisation.



FIG. 3.—Normal flowers after fertilisation.



Reference to the figs., some of which are taken from A. Bonnet's "*Selection as applied to the Vine*" illustrate the different possible occurrences.

Figs. 4, 5, and 6 illustrate, on a magnified scale, the structure of a normal grape vine flower and show the bud, then the peculiar

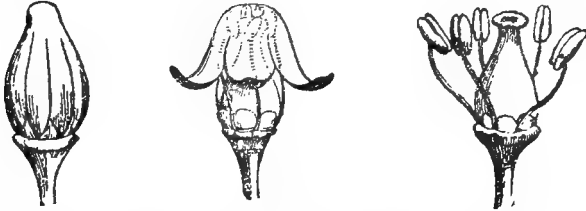

FIG. 4.—A grape vine floral bud.

FIG. 5.—Same showing the petals of the corolla detached from the base and united above, pressing the anthers against the pistil.

FIG. 6.—Same with the corolla removed, and showing the anthers ready for excision.—(FOEX.)

way the petals unfold from the base of the calyx. This dislodgment of the cap causes a jerk which scatters the pollen in the anther sacs on the stamens (Fig. 6). This pollen comes into contact with the stigma of the pistil which carries it to the ovary.

Free setting varieties have the stamens erect, forming a cluster round the inflated tip or stigma, a position which is found advantageous to the proper fertilisation of the ovary. These vines, which constitute the majority, are perfect hermaphrodites.

Climatic conditions, it must be evident to all who have any experience of Western Australian climate, are here in every way favourable to the free setting of the grape vine blossoms. Even the muscat of Alexandria, that queen of all grapes, which is discarded in the Eastern States on account of its defective setting, fruits here to perfection. In the coastal districts, especially from the Murray Estuary as a Southern limit to the Murchison at the North, a badly set bunch is more the exception than the rule. The climatic conditions which are unfavourable to the free setting of grapes are in the main sudden and excessive changes in the temperature; persistent rain or drying land winds at the period the blossoms are opening.

When vines fail to set properly on that account, either pinching back of the fruitful shoots or cincturing under the joint from which issues the bunch will, if practised a few days before blossoming, cause it to set better. (See figures 7 and 7A.)

Zante currants especially are made more fruitful by means of cincturing, as already mentioned on page 262. This is best done at blossoming time (end of October or early in November on the Swan). Double-bladed knives or seraping knives like those used

for scarring rubber trees in the tropics are used. It is not essential that the bark be removed. If made too wide, waxed calico wrapped over the cincture causes the healing callus gum to form readily.

If pinching is practised only the shoots issuing from long, or bearing rods should be so treated and not those from short or wood spurs, as pinching favours the growth of laterals and inter-

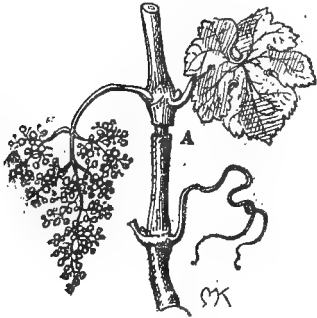

FIG. 7.—Annular incision at A.



FIG. 7A.—Vine shoot pinched back.

feres with the spur and rod system of pruning. New shoots are undesirable where vines have been sprayed to guard against fungoid diseases. In large vineyards it is not easy to discriminate between shoots growing from rods or those from spurs, and for that reason cincturing on the stem at blossoming time is preferred.

Constitutional defects very often cause bad setting.

A seedless grape is a defective grape. The “seedless muscats,” for instance, are grapes which have been imperfectly fertilised, and in some seasons they are more or less noticeable. These “shot grapes” occur at times with nearly all varieties. Raisin des Dames, Grand Centennial, Madeleine Anjevine are particularly affected with us.

The following figs. show at a glance in what respect some flowers show malformation:—

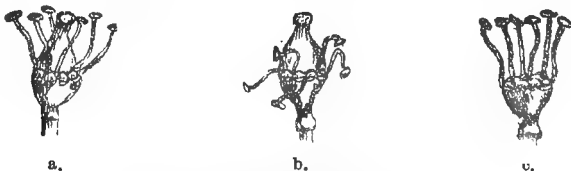

FIG. 8.—(a.) Perfect flower.  
(b.) Reflexed stamens.  
(c.) Staminate flower.

Whenever the stamens fall away from the pistil and are deflexed the act of pollination cannot very well take place and the bunch sets badly.



FIGS. 9 and 10.—Sterile flowers opening rose-like.

It sometimes happens that the pistil is altogether absent, and as this organ contains at its base the ovaries or germ of the future fruit, that absence means permanent sterility.

Other flowers are sterile owing to the peculiar way they expand. Instead of the petals unfolding from the base as shown in Fig. 5, they open rose-like from the top, and when they thus open, there is no jerk and no scattering of pollen, and consequently bad setting; or it happens that the stamens remain stuck to the petals and are shorter than the pistil, and are not able to reach up to the gummy secretion on the stigma.



FIG. 11.—Double flowers.

The various floral organs, moreover, undergo at times modifications which prove obstacles to their fertilisation. Thus whole bunches are seen to turn into tendrils; or, owing to a thickening of any one of the floral organs, the flower assumes the appearance of being double. Such flowers are always sterile.

All these structural defects are hereditary and liable to be transmitted through cuttings, hence the importance of eliminating such vines from a vineyard by grafting on them scions from fer-

tile vines, and also the advisability of rejecting any cutting from them for the purpose of planting. Other constitutional causes as well influence the bearing of vines and lead to imperfect setting.

The bunches are loose and contain berries of various sizes, with numerous blanks between. A lowering of the vitality of the plant consequent upon attacks of *oidium*, or other fungous diseases, predisposes vines to this form of bad setting.

This accident may also be caused by a sudden drop in the temperature, by continuous rain at blossoming time, or by hot blasts of drying wind. Although a few berries which set properly grow to their full size, numerous small ones never grow very large, and are devoid of seeds. They ripen and are as sweet as the others. The *Black Morocco* grape is particularly subject to this form of bad setting or shanking. The explanation given of this peculiarity is that for one or other of the causes mentioned above, a few flowers only set and the others are blighted. A number of the more backward blossoms, which generally fail to set when the first blossoms have turned into fruit, then open and form fruit. These, however, located on the same bunch alongside others which are growing rapidly, are checked, remain small and seedless.

Amongst the remedies suggested to counteract the effect of bad setting are:—Selection of cuttings from fertile vines, pinching back of shoots, ring-barking, sulphuring at blossoming time, and grafting on the sterile plants.

The shape of the leaves often furnish an indication regarding the fruitfulness of vines. In every vineyard may be noticed plants, often very vigorous, growing leaves which are comparatively more deeply indented than others on vines of the same variety. These plants are generally less fruitful than the others; they carry smaller and fewer bunches, or are not fruitful at all. They are known as "wild" vines by the growers. Being particularly luxuriant, cuttings are at times selected from these plants which, however, almost invariably transmit to the vines issuing from them the same characteristics of sterility and of excessively vigorous growth which were exhibited in the parent.



FIG. 12.—Bunch badly set.—(FOEX.)

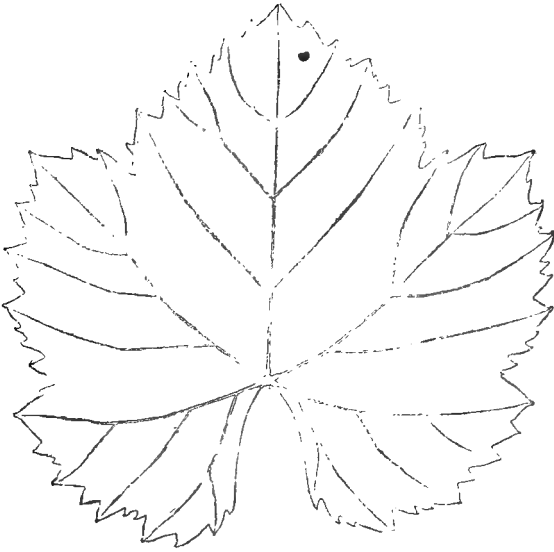

FIG. 13.—Leaf of Aramon from fruitful arm.

The same characteristics are often seen on leaves growing on a sterile water shoot or sucker issuing from a vine stump.

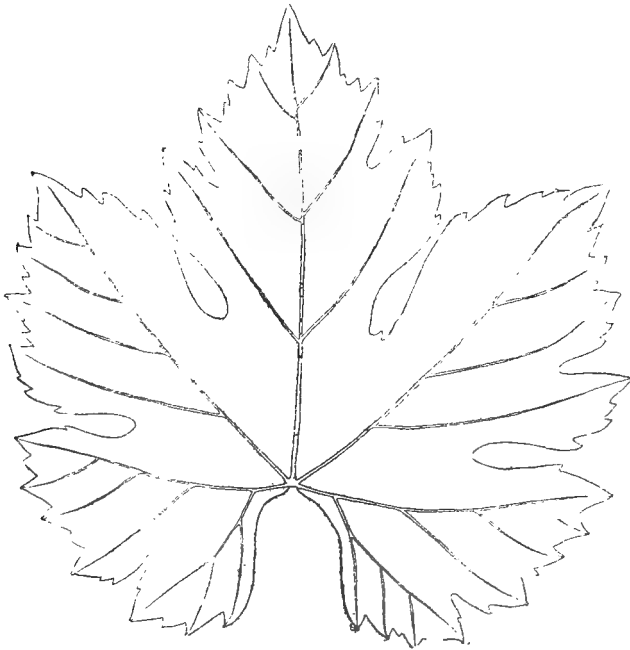

FIG. 14.—Aramon leaf from a sterile sucker on the same vine.

From what we know, therefore, of the fertility of particular vines, or particular parts of grape vines, it is evident that selection enables us to eliminate from a vineyard all unproductive stock by means of grafting, or avoid reproducing undesirable features shown in the parent vine.

## INSECT AND FUNGOID PESTS.

### TREATMENT AND REMEDIES.

Until of late years little or no attention was paid to the damage caused by insect and fungoid pests to cultivated crops.

In the old days of farming and fruitgrowing pests were regarded in the light of an unavoidable calamity, and a visitation of Providence; their nature was shrouded in mystery, or they were either entirely unknown in some parts of the world, or else were often met with, under a mild form, in certain localities; a great many, by transplantation to surroundings somewhat dissimilar to those by which they were influenced in their original *habitat*, have subsequently developed more pronounced and distinct characteristics, and have consequently forced themselves to the notice of cultivators.

These so-called new pests, either insects or fungi, are as ancient as the world, and although they are greatly influenced by their immediate surroundings, by the food at their disposal, the climate in which they live, by the enemies they have to contend with, and by many other circumstances of various nature, they nevertheless spring from parent individuals in every respect like themselves.

Every season, almost, we hear of the appearance of new pests, and it is more than likely that, for a great number of years to come, the list, already formidable, of the sorts of insects and fungi that invade and prey on our crops will gradually be made longer still, by the addition of more unwelcome enemies.

Various factors combine to bring about this undesirable state of things.

In the first instance, we have seen that new conditions of life may develop propensities of a distinctive nature; or, again, the partial extermination of some parasites of these pests, either owing to unfavourable surroundings or the use of insecticides, by breaking the balance of nature, may insure the preponderance, to an alarming degree, of certain species of pests. By the constant and more rapid interchange, on the other hand, of plants, fruits, seeds, and cuttings of all sorts of ornamental, economic, or useful plants, from all parts of the world, many of the parasites of plants have been widely disseminated, without, in a great many instances, their own particular parasites having been brought with them; and thus the appearance of hitherto unknown pests is accounted for in countries until then free from them.

For, as it is so concisely expressed in Dean Swift's oft quoted couplet—

The little fleas that do us tease  
 Have other fleas that bite 'em;  
 And these, in turn, have other fleas,  
 And so on *ad infinitum*.

To ward against the importation of noxious pests, the Government of Western Australia, profiting by the errors and the experience of older fruit-growing countries, have passed a Fruit Pest Act, which provides for the disinfection, on landing, of plants and fruits, for the purpose of checking any possible importation from abroad of pests inimical to fruit trees and vines.

These pests are of two classes:—the first of these are *noxious insects*; the second, *parasitic fungi*.

Insects vary greatly in their shape, size, and colour, but on broad lines they all possess, when seen in their full-grown stage, certain features which differentiate them from other animals. They possess three pairs of legs, attached to a body divided into three definite portions—a head, a thorax, and an abdomen.

Some of them—indeed, the majority—undergo during their development well-marked transformation or stages: 1st, the egg; 2nd, the larva or caterpillar; 3rd, the pupa or chrysalis; 4th, the adult or imago stage. Moths and butterflies, amongst others, belong to this class. In two or, may be, three periods of their transformation they take no food, and are fixtures; during these periods they do no actual harm. Thus, butterflies and moths are inert in the egg as well as the pupa stages; and some of them, such as the codlin moth for instance, do not feed. Yet it is during these periods of rest and transformation that it is often easier to attack them. These insects undergo what is called *complete transformation*, in contradistinction of others which undergo *incomplete transformation*. This second class, such as grasshoppers and locusts, have eggs which, in hatching, give forth young insects which only differ from the full-grown ones in size and in possessing no wings. Instead of changing from larva to pupa, they proceed, by a series of moulting or casting off their skin, to the mature stage, and become imago. During these successive moultings they are known as “nymphs.”

Again, some insects lay eggs, and are “oviparous”; while others bring forth their young alive, and are “viviparous.” The majority of them, however, proceed from the egg, whether that egg is deposited and cemented to the plant by means of a viscous secretion or whether they give birth to young ones. In the latter case the female insect generally carries the egg internally until the hatching period arrives.

So much for the life history of insects, considered broadly. A number of varieties depart from the pattern laid down in several

minor details which cannot be touched upon in this paper, although a clear understanding of these particularities is of great assistance in combating pests. They often constitute the weak point of the armour it is meant to penetrate, and serves as a guide in directing the attack against them.

Almost as important as an undertaking of the life history of pests is a knowledge of the manner they attack plants when taking their food.

In that respect noxious pests may be considered, irrespective of their classification, names, shape, or colour, into two general types: *biting or chewing insects* and *sap-sucking insects*. The former are often leaf-eaters or bark-nibblers, or, again, wood and fruit borers. They are provided with jaws by which they can gnaw the surface of the food-plant, and chew it.

The latter feed on the juices of the inner tissues of the host-plant. They are armed with a pointed tube-point beak, which they thrust into the tissues of their host-plant, and suck out the sap.

Of the biting or food-chewing insects, some are:—

- (1) Root-eaters; such as the white worm of the cockchafer; the larvæ of the cicadæ.
- (2) Others, bark-nibblers; as certain kind of beetles and of weevils.
- (3) Some are leaf-eaters; as slugs, caterpillars, saw-flies' larvæ, the carpenter bee.
- (4) Others injure the bud, the blossom, or the fruit; as the strawberry weevil, the codlin moth.

Of the sucking insects, in a like manner, some are: -

- (1) Root-sucking insects; as the woolly aphis and phylloxera of the vine.
- (2) Others, ordinary bark-sucking insects; as the mealy bugs.
- (3) Some leaf and bud or fruit-sucking insects; as the rose and the orange aphis, the red and other scales, and plant bugs.

When fighting biting insects, their food plant is best coated with substances which will act as internal poisons; whereas, when directing the attack against sap-sucking insects, the treatment must be such as hurts and kills by direct contact; they are external irritants, acting from the outside, either closing the breathing pores or killing by irritation of the skin.

*Arsenate of Lead* is in many respects the most satisfactory form of arsenical poison used for combating the first class of insects named. Take loz. of dry arsenate of lead powder, mix to a paste and add to three gallons of water, stirring thoroughly. The



commercial paste form is more convenient, the quantities used depending on the particular brand, as these contain more or less moisture. Of Swift's brand, which is generally stocked, 2lbs. are mixed to each 50 gallons of water.

*Paris Green* is another arsenical poison much used. It is a chemical combination of arsenic and copper. When unadulterated it contains 55 to 60 per cent. of arsenic. It is almost insoluble in water. It is applied either—1st, dry in a state of impalpable powder, mixed in the proportion of loz. of Paris green with 2lbs. flour, slaked lime, road-dust, or ashes; 2nd, or in a liquid mixture in the proportion of loz. in 10 gallons of water. It should not be used in conjunction with any acid substance which would dissolve the arsenic it contains and make it caustic, but, on the contrary, it is always a good plan to add to it a handful of lime, which has the property of turning insoluble any trace of caustic arsenic it contains. Being a heavy substance, it quickly settles to the bottom of the pumping tackle, and requires agitating. A little glue or flour paste may be added, to cause it to adhere better, especially to plants with glossy leaves.

*Hellebore*, unlike the arsenites, which are mineral poisons, is a vegetable poison, and is less dangerous. It is a powder made of the roots of the white hellebore, and kills both by contact and by being eaten. Very effective when fresh, it loses its strength by standing. In doses loz. to three gallons of water it is much used against the pear slug and leaf-eating worms.

*Pyrethrum*, or Insectibane, is also a poison, and is effective when fresh, but loses strength when exposed to the air. It is made from the powdered flowers of plants of the genus *Pyrethrum*. That light-brown powder is dusted over the plants or sprayed, in the proportion of *Pyrethrum* one tablespoonful, boiling water two gallons. It kills by contact, and should be applied as long as the insects persist. Burnt over hot coals in the conservatories and greenhouses, it rids plants of aphids and other insect pests. *Pyrethrum* are easily cultivated, make pretty borders, and a supply of fresh flowers could, without trouble, be raised in every garden.

*Kerosene*, in the form of an emulsion with soapsuds, or mechanically mixed with water in the form of a misty spray, in the proportion of one of kerosene and four of water, will kill nearly all insects, and not injure the foliage.

*Resin Compound* is known to be very effective against scale insects. One of the best formulas is: caustic soda, one pound; resin, five pounds; water, 25 gallons. Two ounces of Paris green may be added to this when used.

*Sal Ammoniac* (chloride of ammonia) at the rate of  $\frac{3}{4}$  to loz. per gallon of water, is a cheap and efficacious spray against red scale.

*Sunlight Soap*, manufactured by Lever out of coconut oil is also a very useful spray for aphides, etc. Dissolve a cake of Sunlight soap in 2 gallons of hot water, and spray warm. It can be used at any time, even when the blossoms are out.

*Tobacco* is one of the safest and most valuable insecticides, and may be applied in several ways; either as a tobacco dust against slugs and aphids, or as a decoction of three to four gallons of water to one pound of tobacco; or in fumes, when burnt in the greenhouse.

Highly concentrated nicotine extracts are obtainable and are convenient, mixing readily with cold water and being easily applied. *Black Leaf 40* is one of these preparations. Where tobacco waste can be obtained cheaply, small quantities of the wash may thus be made: tobacco waste, 1lb.; washing soda,  $\frac{1}{2}$ oz.; water, 3 gallons; pour the water boiling over the tobacco waste, and let draw for twenty-four hours. Soapsuds, if added, sometimes curdles and chokes the spray pump valves.

*Carbolic Acid*, especially in its crude state, is a valuable insecticide as an emulsion made by mixing one quart soft soap, or about one pound of hard soap dissolved in two gallons of boiling water, and then adding one pound crude carbolic acid; and, applied with a cloth or a brush, it is efficacious in preventing the attack of tree borers. It must not, in that state, be applied to the foliage.

*Bi-Sulphide of Carbon*, a very volatile fluid, the fumes of which are destructive to all animal life, is used for killing insects underground; this is done when the plant is dormant, by boring a hole into the ground and pouring a little carbon bi-sulphide and kerosene mixed. It is highly inflammable.

*Coal Tar* is excellent to drive insects away, or entrap them.

*Hot Water* at a temperature of about 125 deg. F., is very efficacious for killing plant lice. Amongst other substances which are used against insects must also be mentioned lime and gas lime, quassia chips, kainit, fir-tree oil, sulphate of copper.

*Natural Checks*.—Although economic entomologists have already tested many valuable insecticides, and so compounded them that they kill insects but leave plants uninjured, yet there is, in keeping noxious insects in check, even more efficacious allies than the spray pump and the insecticidal mixtures.

Western Australia is particularly indebted to Mr. Geo. Compere, one time entomologist of the Department of Agriculture, for his whole-hearted work in introducing many valuable insect pest parasites, collected in the course of missions of discovery in many parts of the old and of the new world. Among such introductions are ichneumon wasps parasitic of scale pests, viz., Black, Brown, Red, Cymbiform, San Jose; internal parasites of the cabbage moth and cabbage aphid; several aphid and scale-eating ladybirds, etc.

All insects, injurious or beneficial, have many natural enemies of their own to contend with. Some are of a higher order in the scale of animal classification, such as lizards, frogs, and other reptiles; birds, moles, etc. Others, more numerous, belong to the insect world itself.

Amongst these, some attack noxious insect pests from the outside, and either devour them or suck their vital juices; they are called *predaceous* insects, *e.g.*, ladybirds, spiders, soldier bug, black ground beetle.

Others, called *parasitic* insects, differ from the predaceous ones, in so far as they live inside the bodies of their victims, and ultimately kill them. Amongst these parasitic insects the more numerous are ichneumon wasps, which entomologists classify amongst the hymenopterous, or four-wing flies. Another class of flies, with only two wings, and for that reason known as dipterous insects, contribute largely to the ranks of insect parasites.

But even these parasites are frequently subject to the attack of still smaller parasites, which prove as fatal to them as they did to their insect hosts. The first of these parasites are, for that reason, known as "primary parasites," to differentiate them from the second, called "secondary parasites." When introducing parasites into an orchard or a garden, therefore, it is of the greatest importance that we should have a clear idea whether we are introducing an ally which will prove beneficial, or whether we will add to the list of our pest enemies another insect which will prove mischievous. Such a work is better left in the hands of experienced people, and may prove a dangerous tool in those of the tyro gardener.

Besides insect parasites, injurious insects are also attacked by even more minuscule foes. These are germs of contagious diseases, which at times stop an insect plague with remarkable suddenness.

These germs are of two orders: some *bacterial* and inward, *e.g.*, green potato and tomato caterpillars; others, superficial, cover their victims with silklike threads, and belong to the *mould* family, *e.g.*, the African locust fungus—the housefly fungus.

## GARDEN AND ORCHARD CROPS—THEIR PESTS AND REMEDIES.

In a tabular form, I have grouped those insect and fungoid pests which attack our orchard and garden crops. A few words concerning the more prominent amongst these pests will follow.

---

## GARDEN AND ORCHARD CROPS—THEIR PESTS.

NOTE.—Pests marked thus\* have not so far been observed in Western Australia. The intensity of the disease will regulate the frequency of the treatment.

PLANT.	DISEASE.	DIRECTIONS FOR APPLICATION.
APPLE	Scab ( <i>Fusicladium</i> )	Before buds start, Nos. 1, 2, or 6. Before blossoms open, No. 3. When fruit sets, No. 3. End of the year, Nos. 3 or 4. Later on, if necessary, Nos. 3 or 4.
	Monilia or Mummification	Gather fruit left hanging, and burn. Burn gummy degeneration of wood. Wash stems before spring with 10 per cent. solution sulphate of iron. Follow up with No. 3.
	Bitter or Ripe Rot	Collect and burn diseased fruit. When fruit is fully grown, every 15 days Nos. 1, 2, or 15.
	Bitter Pit	Before buds start, No. 1. When fruit sets, No. 3. When fruit is fully grown, Nos. 3 or 4. Sub-drain and fertilise with lime and potash.
	Mouldy Core	When fruit is fully grown, Nos. 3, 4, or 15.
	Water Core	More prevalent in moist seasons, especially in early sorts; not very injurious.
	Powdery Mildew	Before buds start, Nos. 15, 1 or 2. Every 10 or 12 days in infested nurseries, Nos. 3 or 4. In summer, sulphur.
	Canker	Cut back and burn diseased branches. Apply Nos. 6 or 9.
	Sun Burn	Low Heading, apply No. 9 on stem and main limbs.
	Fumagine or Sooty Mould	Remove scale insects and fumagine will cease. Apply No. 14. Starch, $\frac{1}{2}$ lb. in hot water, 1 gallon, will, when dry, peel off and leave tree clean.
	Woolly Aphis	In winter, Nos. 6, 10, 14, or 20. A fortnight after, Nos. 10 or 14. Use blight-proof stock, and No. 9.
	Black Aphis	At first appearance, Nos. 7, 8, 14, or 18. Ladybirds and parasites.
	Red Spider and Mites	Clean cultivation. In winter dress limbs with No. 6. Later on, 15, or powdered sulphur. Two or three dressings during spring and early summer.
	Codlin Moth	Scrape all loose bark away. Use and visit cloth traps round trunks. Spray No. 13 before and after blossoming.
	Cut Worms	Towards the close of the afternoon place a little lump of No. 16 close up to the tree or plant. A ring of kainit round plants acts as fertiliser as well as repellent.
	Scale Insects	In winter, Nos. 6, 10, 12, 14, or 20. Two or three applications at frequent intervals if necessary. Hydro-cyanic gas treatment.
	Leaf-eating Insects	Nos. 11 or 13 whenever necessary.
	Bud and Bark-eating Beetles	Shake tree in the cool of the morning, and collect insects on sheet of brown paper or calico. Spray with Nos. 11, 12, or 13.
	Borer	Look on dying or dead limbs for excreta, indicating the presence of borers. Plug holes with probe dipped in carbolic acid and tar. Cut off and burn badly injured branches. Use No. 9.
	Fruit Fly	Carefully pick and burn all affected fruit before grubs leave to pupate in the ground. Use No. 21 or 22.
	Moss and Lichen	Whitewash or spray with Nos. 1 or 6.

PEAR	...	Scab	...	...	Same as for Apple Scab.
		Phytophth (Mite)	...	...	Same as Red Spider and Mites on Apple.
		* Pear Slug	...	...	Wait till slugs appear and then use Nos. 11, 12, or 13.
		Codlin Moth	...	...	See under Apple.
		Borer	...	...	See under Apple.
		Powdery Mildew	...	...	See under Apple.
		Red Spider	...	...	See under Apple.
		Aphis	...	...	At first appearance, Nos. 7, 8, 12, 14, 18, or 20.
		Scale Insects	...	...	See under Apple.
		Leaf-eating Insects	...	...	Nos. 11, 12, or 13, whenever necessary.
		Bud and Bark Nibbling Beetles	...	...	See under Apple.
		Fruit Fly	...	...	See under Apple.
CURRENT	...	Scale Insects	...	...	See under Apple.
GOOSEBERRY	...	* Mildew	...	...	Potassium sulphide (liver of sulphur), 4oz. to 1 gallon of water, every two or three weeks.
ALMOND	...	Leaf Rust	...	...	Collect and burn diseased leaves. In spring and summer, Nos. 3 or 4.
		Shot Hole	...	...	Collect and burn diseased leaves. Before buds burst, No. 1. When fruit is set, No. 3; later on No. 4.
		Gumming	...	...	Parc off with knife and gouge out diseased wood. Paint over with shellac or other protective cover after swabbing with carbolic lotion.
		Curl Leaf	...	...	Before buds burst, Nos. 1 or 6. When fruit is set, No. 3.
		Black Peach Aphid	...	...	In winter gas lime, kainit, fresh manure, or No. 15 round stem. In spring, Nos. 7, 8, 12, 14, 18 or 20.
APRICOT	...	Other Aphids	...	...	In spring and summer, Nos. 7, 8, 14, or 18.
PEACH	...	Leaf-eating Insects	...	...	Nos. 11, 12, 13.
		Bud and Bark-eating Insects	...	...	See under Apple.
NECTARINE	...	Scale Insects	...	...	In winter, Nos. 6, 10, 12, 14, or 20. Repeat application two or three times, or use No. 18.
		* Slug	...	...	See under Pear.
		Borer	...	...	See under Apple.
		Red Spider and Mites	...	...	See under Apple.
PLUM	...	Fruit Fly	...	...	See under Apple.
		Sour Sap	...	...	Liberaly fertilise with superphosphate of lime. Cut hard back when first signs of wilting show in spring. Patnt with No. 9.
CHERRY	...	Leaf-eating Insects	...	...	See above.
		Bark-eating Insects	...	...	See above.
		* Slug	...	...	See under Pear.
		Borers	...	...	See under Apple.
		Gumming	...	...	See under Peach.
		Fruit Fly	...	...	See under Apple.

## GARDEN AND ORCHARD CROPS—THEIR PESTS—continued.

PLANT.	DISEASE.	DIRECTIONS FOR APPLICATION.
LEMON, ORANGE, AND OTHER CITRUS TREES	Mites ... ..	See above.
	Melanose ... ..	Prune away diseased parts and burn. No. 3 with a little soap to facilitate wetting of the leaves when the fruit sets, and again when half-grown; Nos. 1 or 2 before blossoming.
	Maori or Mites ... ..	Nos. 7, 15, or powdered sulphur.
	Black Aphis ... ..	Nos. 7, 8, 14, or 20.
	Scale Insects ... ..	See under Apple. Protect ladybirds and scale parasites. Hydro-cyanic gas treatment. Omit No. 6.
	Leaf-eating Insects ... ..	See above. For Red Scale: Sal Ammoniac, ½ oz. to 1 oz. in water, 1 gallon; spray two or three times at a fortnight's interval.
	Bark-eating Insects ... ..	See above.
	Crown Rot ( <i>Mal de Gomme</i> ) ... ..	Avoid deep planting, stagnant water; pare off with a knife; swab with carbolic lotion and paint over; avoid organic manures; sometimes caused by crickets hidden in mulching. Avoid lemon stock.
	Die Back ... ..	Often due to excess of organic nitrogenous manures. Often seen on peaty soil. Drainage. Fertilisers. Nos. 1, 2, or 3, if due to fungoid parasites.
	LOQUATS ... ..	Black Spot ( <i>Fusicladium eribotryæ</i> ) ... ..
BEANS ... ..	Aphis ... ..	Spray with Nos. 7, 8, 9, 14, 15, 19, or 20.
	Leaf-boring Insects ... ..	Spray with Nos. 9, 10, or 11, whenever necessary.
	Anthraxose ... ..	See Peas.
BEET ... ..	Bugs ... ..	Hand picking.
	Leaf-eating Fly ... ..	Pick off and burn affected leaves.
CABBAGE ... ..	Aphis ... ..	Spray with Nos. 7, 8, 10, 14, 15, 19, or 20.
	Moth and Caterpillar ... ..	Spray with Nos. 11, 13, or 19, or sprinkle with Paris green, 1 oz., in flour or lime, 5 lbs.
	Boring Moth (Ball Head) ... ..	Cut and burn as soon as noticed.
	Leaf-eating Insects ... ..	Spray with Nos. 11 or 13.
	Slugs ... ..	See below. Poison bait.
TURNIPS ... ..	Stinking Head of Cabbage ... ..	Caused by a yellow bacterium. Rotation of crops. Suppress cruciferous weeds, destroy slugs and cabbage-feeding caterpillars.
FIG ... ..	Fruit Bugs ... ..	Hand-picking.
	Scales ... ..	See above.
MULBERRY ... ..	Fruit Bugs ... ..	Hand-picking.
	Scale Insects ... ..	See above.
OLIVE ... ..	Fumagine ... ..	Remove scale insects and fumagine will cease.

ONION ...	...	...	...	...	...	...	...	See Red Spider and Mites under Apple. Spray with Nos. 1, 2, or 4.
PEAS ...	...	...	...	...	...	...	...	Sow clean seeds, or pickle them in bluestone solution like wheat. Burn diseased vines and trash. Rotation of crops. Spray with Nos. 1, 2, 3, or 4. Directly after picking, place peas for one hour in stove at 145° F. Close bin and generate an atmosphere of carbon bisulphide fumes.
POTATO ...	...	...	...	...	...	...	...	<i>Alternaria solani</i> .—Plant sound tubers. Spray with Nos. 1, 2, 3, or 4. Soak seeds for two hours in corrosive sublimate. 2oz. in 20 gallons of water. Formalin Dip is not so dangerous. <i>Oospora scabies</i> also attacks Beet-root. The fungus or its spores remains several years in the soil. Rotation of crop, avoiding Potatoes following Beet where scab is bad. Nos. 11 or 13. Store under ground if possible. 3oz. in 10 gallons of water. <i>Phytophthora infestans</i> .—Spray with 1, 2, 3, or 4. See above.
ROSES ...	...	...	...	...	...	...	...	In spring and summer, Nos. 3 or 4. Sulphur, or No. 15. See above. See above. See above. Sulphur or No. 15.
STRAWBERRIES ...	...	...	...	...	...	...	...	Destroy affected leaves. In bad cases mow the bed and make a litter; burn leaves over plant. Spray before blossoming, and after fruit is picked, with Nos. 1, 2, 3, or 4. See above.
TOMATOES...	...	...	...	...	...	...	...	Tobacco dust and slaked lime. Kainit and lime 1 to 4 applied with bellows. Sulphuric acid solution 10 per cent. sol. (1½ pint in 1 gallon water) after mowing plants in the autumn. Spray with Nos. 1, 2, 3, and when fruit ripens, No. 4. Small cherry and plum tomatoes free. Stake or trellis vines. Clean seed. Rotation. Burn diseased vines and fruit; spray every fortnight with Nos. 1, 2, 3, and later No. 4. See above. Pick and destroy affected fruit.
VINES ...	...	...	...	...	...	...	...	Sulphur, Par-oidium, when shoots are 12 inches long; again before blossoming, when fruit is set, and every fortnight until the grapes turn. In winter No. 5. In summer, sulphur, lime, and powdered green coppers, or hydraulic cement and sulphur, or par-oidium powder. Drainage, liming. In bad case, pull out and burn vine. See under Apple. See above. Spray with Quibbel's liquid disinfectant, 3oz. in one gallon water. Plant in sand; inject No. 17 in water. Root up and destroy vine until a general plan of working vines on phylloxera-proof stock is adopted.

Thrips ...

Rust ...

Anthracnose ...

Pea Weevil ...

Leaf Blight ...

Scab ...

Boring Moth ...

Potato Rot or Irish Potato Blight. ...

Leaf-eating Insects ...

Rust ...

Mildew ...

Aphides ...

Leaf-eaters ...

Bark-robbers ...

Mealy Bugs ...

Leaf Blight ...

Cut Worms ...

Slugs ...

Black Rot (*Cladosporium*) ...Blight (*Macrosporium*) ...

Leaf-eating Insects ...

Boring Caterpillars ...

Oldium ...

Anthracnose ...

Mouldy Root ...

Cut Worms ...

Leaf and Bark-eating Insects ...

Chinch Bugs or Rutherglen Flies ...

\*Phylloxera, or Vine Aphid ...

GARDEN AND ORCHARD CRGFS.—THEIR PESTS—*continued.*

PLANT.	DISEASE.	DIRECTIONS FOR APPLICATION.	
<i>VINES—continued.</i>	Calandra	Brown short beetle, injurious to buds and young fruit. Grub stage passed on roots in winter. Clean cultivation. Trap in fur cones or balls of crumpled leaves placed in fork of vines.	
	Opossums	Strychnine and tea leaves on pieces of board or tin, nailed to posts and removed in the morning; traps, shooting.	
	Vermin	Wire netting; blood-smearing, as high up as rabbits can reach, will keep them away. Baits, traps, shooting.	
	White Ants	No. 17. Clean cultivation or arsenical compounds.	
	Silver Eyes	Reduce mutton fat spread on piece of tin, sprinkle with strychnine, and tie up branches offavour-its tree. Honey and strychnine, shooting, bird-lime.	
	Grasshoppers	Clean cultivation. Bait No. 16. Sprays Nos. 10, 11, 12, or 13. Ditching, rolling, ploughing under the eggs. Introduce grasshopper fungus.	
	Wireworms	Autumn ploughing, poisoned baits, rotation of crops.	
	Cockchafers (White Grubs)	Luring beetles by lights over trays into water with skim kerosene. Liberal use of potash fertilisers. Protect magpies and birds.	
	Slugs	Ducks are good scavengers; No. 7, or tobacco powder over plants; quicklime or ashes round beds; traps, consisting of arsenicated cabbage leaves spread over the ground; thin boards covered with films of grease or rancid butter attract many at night; pick and destroy. Powdered kaimit mixed with quicklime dusted over the plants when the dark comes and the slugs are feeding, kills a great many.	



## REMEDIES FOR GARDEN AND ORCHARD CROP PESTS.

### No. 1.—BORDEAUX MIXTURE (Full Strength for Winter Spraying).

<i>Sulphate of Copper (bluestone)</i> ... ..	6lbs.
<i>Quicklime (freely slaked)</i> ... ..	4lbs.
<i>Water</i> ... ..	22gals.

(a.) Dissolve the bluestone in 10 gallons of water by placing it in a sack suspended in the water and moving the sack about, when the sulphate will quickly dissolve. (b.) Make a whitewash with the lime, strain to separate the grit, and bring the milk of lime to 10 gallons. Mix *a* and *b*. and make up to 22 gallons. Use only wooden or earthenware vessels, When the foliage is out, use the half-strength mixture by diluting in double the volume of water. To determine if the mixture is safe to use on tender foliage, insert a new nail or the blade of a penknife for at least half a minute ; if copper is deposited on the steel, lime must be added.

Another test is the Ferrocyanide Test:—Add a few drops of a strong solution of yellow prussiate of Potash. If lime is lacking, and if there is an excess of sulphate of copper the mixture will turn black, but it will show no change of colour if the quantity of lime is sufficient.

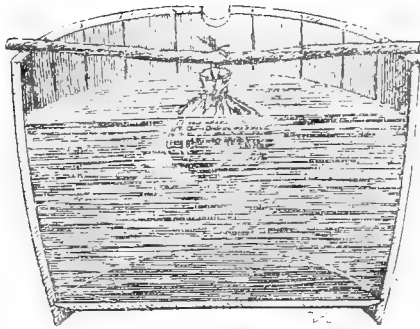

Sulphate of Copper dissolving  
in a tub of water.

### No. 2.

The same with a small quantity of mola-ses added.

### No. 3.

The same as Nos. 1 or 2, with 44 gallons water. Half strength for tender foliage.

## No. 4.—BURGUNDY MIXTURE.

<i>Sulphate of Copper</i>	...	...	...	4lbs.
<i>Carbonate of Soda (Washing Soda)</i>	...	...	...	5lbs.
<i>Water</i>	...	...	...	22gals.

(a.) Dissolve bluestone as in Bordeaux Mixture.

(b.) Dissolve the carbonate of soda ; mixing the two solutions gradually, stirring the while. Make up the quantity with water. A gelatinous hydrocarbonate of copper is formed. In W.A. it is easier prepared than Bordeaux Mixture, good lime free of grit being scarce. Adheres better to foliage than does Bordeaux mixture, its only drawback is being a little more expensive. The precipitate, which is bluish green, remains longer in suspension in the liquid than does Bordeaux Mixture. Molasses,  $\frac{1}{2}$ lb. to the quantity above added a few hours before using, makes it more adhesive ; sucrate as well as hydrocarbonate of copper being formed which is dark red, very light and very adhesive. For summer formula use 4 : 5 : 44. Do not add Paris Green to this as the soda dissolves the arsenate and would cause leaf burn.

The addition of Paris Green or of arsenate of lead 2ozs. to every 22 gallons of the spray will get at nibbling insects as well.

These two sprays should only be mixed together when ready for use, as they deteriorate in keeping and become less adhesive.

## No. 5.—SULPHATE OF IRON SWAB.

<i>Sulphate of Iron (Copperas)</i>	...	...	25lbs.
<i>Sulphuric Acid</i>	...	...	7lbs.
<i>Warm Water</i>	...	...	10gal.

Pour the sulphuric acid over the copperas, and then add the water. No metallic vessel should be used ; an open barrel treated inside and out with paraffin wax or tar is the best. Apply with a swab made of binder twine or of woollen rag, no metal to be used. After pruning, just before the buds open, the copperas is not indispensable. A 10 to 12 per cent. solution of sulphuric acid (six to seven quarts of acid in 25 gallons water) is at times used as a substitute. The acid solution may also be applied as a spray from a pump fixed on a barrel drawn on a sledge or on a spring cart. The pump and nozzle should be thoroughly washed every day, immediately the spraying is stopped. It is a good plan to have the pump annealed with lead or lead galvanised.

## No. 6.—LIME, SULPHUR, AND SALT.

(A winter spray for deciduous trees only.)

<i>Quicklime</i>	...	...	...	30lbs.
<i>Sulphur</i>	...	...	...	20lbs.
<i>Salt</i>	...	...	...	10lbs.
<i>Water</i>	...	...	...	60gals.

Reduce the sulphur to a paste or sift ; add  $\frac{1}{4}$  the quick-lime and boil in five gallons of water, then add  $\frac{1}{4}$  lime ; again boil, and so on,

till the sulphur is quite dissolved. The boiling will take an hour or so and the liquid will turn amber colour. Then add the salt previously dissolved in  $\frac{1}{2}$  the water and boil half an hour longer. Add enough water to make 60 gallons, stirring all the time, Strain through a cheese-cloth sack. Use coarse nozzle, and be careful of hands. An iron tank is used, and not a copper boiler. A steam jet can be used instead of boiling over fire, and in that case a wooden tub will do.

This formula gives good results against San Jose scale, Excess of lime is advisable, as otherwise, although equal proportions of lime and of sulphur combine entirely, the liquid is very soluble and is readily washed by drenching rain. Besides, a lime crust helps in preventing young scales escaping.

#### No. 7.—TOBACCO DECOCTION.

<i>Home Grown Tobacco, Leaf and Stem or Tobacco Waste</i>	...	...	...	1lb.
<i>Water</i>	...	...	...	3 to 4 gals.
<i>Soft Soap</i>	...	...	...	$\frac{1}{4}$ lb.

The tobacco is placed in a bag, and placed under boiling water with the soap added and boiled for an hour or soaked for several days. Lift the sack, drain. If large quantities are made, add sufficient water to the strong decoction. Pack the residual tobacco round the base of the tree to destroy any aphides on the roots.

Concentrated nicotine solutions are sold in commerce under the name *Black Leaf No. 40*, to which cold water is added as directed.

Tobacco Dust and Lime is very useful against slugs and snails, cabbage moth, etc. Mix in the proportion of 1 to 4 and dust the mixture over the plants early in the morning when the dew is on the leaves. One kerosene tin full of the mixture will do 400 cabbage plants.

#### No. 8.—EUCALYPTUS DECOCTION.

Some people object to poisonous mineral solutions to trees or vines.

Decoctions of Eucalyptus, Blue Gum leaves bruised when freshly gathered, are soaked in tepid water, 1lb. to 1 gallon, then sprayed on the tree, vine or vegetable that bugs have taken possession of. The vine hopper, the stink-bug on pumpkin and melon vines, the spotted diabrotica, the cut worm and all that tribe and ilk will abandon any foliage where the spray is used; it is sticky stuff, and adheres quickly.

## No. 9.—SULPHUR AND LIME PAINT.

Boil for half an hour—

<i>Sulphur</i>	...	...	...	...	...	1lb.
<i>Quicklime</i>	...	...	...	...	...	2lbs.
<i>Water</i>	...	...	...	...	...	3gals.

and thicken to consistency of paint, with fine clay or with flour, and brush over stems and limbs after pruning, will keep rabbits and other rodents away.

## No. 10.—KEROSENE EMULSION.

<i>Kerosene</i>	...	...	...	...	...	2gals.
<i>Soap</i>	...	...	...	...	...	$\frac{1}{2}$ lb.

Boil the soap in one gallon of water. When boiling, remove to another vessel, add the kerosene and churn violently for 10 minutes, or pour with a fall from one bucket into another until the whole forms a creamy mass which thickens on cooling. Will keep. When used, to one part of the emulsion add eight to ten parts of water, according to season. The time required to effect a complete emulsion will depend on the violence of the churning and the temperature of the mixture.

The addition of a little naphthaline dissolved in the kerosene is also recommended.

N.B.—Paris Green or arsenate of lead 1oz. to every 12 to 15 gallons of the emulsion will make this spray effective against sucking as well as against nibbling insect pests.

## No. 11.—SUNLIGHT SOAP.

One cake of Sunlight Soap dissolved in 1 to 2 gallons of boiling water. Use hot—will destroy aphides and such like insects. Add Paris Green or arsenate of lead 1oz. to every 10 gallons if nibbling insects also are present.

## No. 12.—RED OIL EMULSION.

Follow directions printed on tin, viz., 1 in 40 to 1 in 50. Add a little arsenical compound if necessary to get at nibbling insects.

## No. 13.—ARSENICAL SPRAYS.

<i>Paris Green</i>	...	...	...	...	...	4oz.
<i>Water</i>	...	...	...	...	...	50gals.

or 1oz. to 12 gallons. The addition of a little lime will neutralise the caustic property of the arsenic. A little glue or flour will ensure its adhesion to the leaves. To mix well, first make into a thin paste with a little water. Apply with a fine nozzle.

*Arsenate of Lead* is used as a substitute. For first spraying for codlin moth larvae and leaf-eating insects  $2\frac{1}{2}$  lb. of arsenate of lead to 50 gallons of water; for subsequent sprayings,  $1\frac{1}{2}$  lbs. arsenate of lead to 50 gallons of water.

NO. 14.—RESIN AND SODA WASH

<i>Resin (pounded)</i> ... ..	5lbs.
<i>Caustic Soda (70 per cent.)</i> ... ..	1lb.
or,	
<i>Washing Soda</i> ... ..	3lbs.
<i>Fish Oil</i> ... ..	1pt.
<i>Water, to make</i> ... ..	25gals.

Boil ingredients, with enough water to cover, for 1 to 2 hours, adding water slowly if there is a tendency to boil over. The compound will assume the colour of black coffee. Ascertain that mixture will assimilate with water by occasionally pouring a small quantity of mixture into water. If not boiled sufficiently will form a ropy mass in bottom of vessel. Dilute with warm water, stirring all the time to one-third, the first bulk (8 gallons), making a stock mixture to be diluted to the full amount when used. This mixture can be used twice or three times as strong on deciduous trees when dormant.

NO. 15.—IRON SULPHIDE SPRAY.

(For Powdery Mildew of Apple Trees.)

Place 25 gallons of cold water in a barrel and immerse in this 6lbs. of sulphate of iron. When this has completely dissolved, add gradually, stirring all the time, 12 pints of commercial lime-sulphur, 32° Baume.

The addition of the lime-sulphur will produce a bulky black precipitate which, in a few minutes, will begin to settle. To ascertain if sufficient lime-sulphur has been added, carefully dip out with a clean glass a little of the top liquid after settling has been taking place for 5 to 10 minutes. If this liquid is clear, showing no yellow colour, add a little more lime-sulphur to the stock in the barrel, stir well, and after a few minutes settling, again test as before by removing some for examination in a clean glass. This operation must be repeated until the liquid dipped off with the glass shows a pale yellowish tint. When this occurs, no more lime-sulphur is to be added, and the mixture in the barrel must be allowed to stand until the iron sulphide has completely settled, which will take about eight hours. Then the liquid, on top of the black precipitate at the bottom of the barrel, must be syphoned off and thrown away, for it is *useless*, and sufficient water added to bring the mixture in the barrel to 25 gallons.

The above is a stock solution and must be broken down to 1 in 10 before using.

The first application should be made when the blossom buds are showing pink, but while the petals are still folded quite tightly, and a second application after the blossoms have fallen and the fruit has formed.

#### NO. 16.—BAIT.

<i>Bran</i> ... ..	10lbs.
<i>Paris Green</i> ... ..	4oz.
<i>Molasses</i> ... ..	4lbs.

Worked with water to the consistency of stiff dough into balls, and laid at the foot of the plants for cut worms, grasshoppers, snails and slugs.

Fresh leaves of vegetables, sprinkled with Paris Green and water, laid about, also make a good bait.

#### NO. 17.—CARBON BI-SULPHIDE.

Apply with Vermorel's Injector; dose, 10 to 20 grammes to the square yard, or close up to where white ants or phylloxera are.

<i>Bi-sulphide of Carbon</i> ... ..	1 part.
<i>Kerosene</i> ... ..	1 to 2 parts.

#### NO. 18.—HYDRO-CYANIC GAS.

For every 100 cubic feet of space to be fumigated—

<i>Potassium Cyanide, 98 per cent.</i> ... ..	1½ oz.
<i>Sulphuric Acid</i> ... ..	2½ ozs.
<i>Water</i> ... ..	3ozs.

To generate the gas pour the acid slowly into the water in a deep cup or earthenware vessel, add the cyanide to it, and retire quickly, taking care not to inhale the fumes, which are highly poisonous. Fumigate 45 minutes to one hour. This is the stronger winter treatment for deciduous trees when the leaves are off. For summer treatment and for evergreens use half the quantity of chemicals. Cyanide of Potassium is a deadly poison.

#### NO. 19.—TAR WATER.

<i>Boiling Water</i> ... ..	2gals.
<i>Coal Tar</i> ... ..	1lb.

Add tar, drop by drop, to boiling water, and stir violently. If the tar is added in bulk it will not mix. When dissolved, make up to 100 gallons with water. Spray under as well as upper surface of leaves.

## No. 20.—WHALE OIL SOAP.

One pound to two to four gallons water for scale insects ; 1lb. to four to six gallons for mealy bugs, aphides, red spider, etc. Good's No. 3 potash soap, one of the best, made of fish oil, and not more than 25 to 28 per cent. water.

## No. 21.—POLLARD BAIT.

(Against Fruit Fly.)

<i>Pollard</i>	...	...	...	...	...	1lb.
<i>Molasses</i>	...	...	...	...	...	1oz.
<i>Arsenate of Lead</i>	...	...	...	...	...	1½oz.
<i>Powdered Borax</i>	...	...	...	...	...	2ozs.
<i>Water</i>	...	...	...	...	...	1gall.

Mix and stir thoroughly and place in shallow tins or saucers hung on the trees. The borax checks the rapid fermentation of the paste when it becomes useless and must be renewed. Pollard, Mr. J. L. Newman has found attracts the fruit fly.

## No. 22.—MOLASSES BAIT.

(Against Fruit Fly.)

Also found very efficaceous by Mr. J. L. Newman, Entomologist of the Agricultural Department.

<i>Arsenate of Lead</i>	...	...	...	...	...	5ozs.
<i>Molasses</i>	...	...	...	...	...	4lbs.
<i>Fruit Syrup</i>	...	...	...	...	...	1gall.
<i>Water</i>	...	...	...	...	...	3galls.

For making the fruit syrup, about 4lbs. of ripe fruit, peaches or oranges preferable—windfalls or reject fruit will do—are crushed, boiled for one hour in one gallon of water. Strain, add the Molasses dissolved in one gallon of warm water ; reduce to 5oz. of powdered arsenate of lead or its equivalent : ½lb. of the paste to the consistency of milk, mix the ingredients and bring up the volume of the bait to four gallons. Stir when using as a spray on a few branches, preferably on the sunny side of the tree. Start the spraying five or six weeks before the fruit ripens and renew the application every week. Avoid spraying too often in one place—sugar instead of molasses attracts bees. Mix this bait fresh, or it will ferment.

## SPRAYING PUMPS.

Until the mildew appeared in the European vineyards, the only spraying pumps known were somewhat after the fashion of those toy scent-atomizers used by hairdressers, and were almost entirely used in conservatories, for spraying rare and exotic plants.

Since then, however, the necessity of dressing vines with mixtures containing copper salts, and other insecticides, has led to the more general use of specially designed pumps that distribute the liquid with greater rapidity and under the form of minute globules in a fine spray.

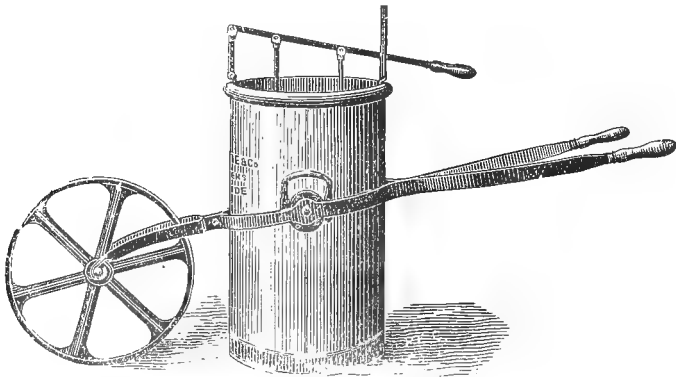

Barrow Spray Pump.

Pumps should be chosen with reference to the amount of work to be done. *Syringes* are hardly suited for extensive out-of-door spraying. *Bucket Pumps* are very serviceable in small gardens. *Knapsack Pumps* are suitable for orchards of young trees, and for vineyards set too close to admit of the use of wheeled machines. *Barrel Pumps* on a sledge or a cart in large gardens and commercial orchards and vineyards. *Power Pumps* worked by petrol engines and carried on wheels offer the advantage of rapidity of work, higher pressure and more thorough spraying with multiple delivery hose and nozzles. Price and weight must be considered.

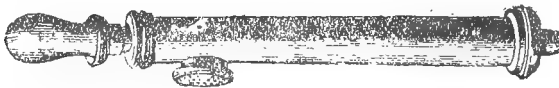

Garden Syringe—the simplest Spray Pump.

A cheap pump, that will distribute clogging and corrosive mixtures all the time, and be simple enough to stand the rough using of farm and orchard hands, who know little more about spraying than to work the pump handle, is not very easy to get. All parts of component spray pumps must be of the very best and suitable description—hose, nozzle, means of controlling the liquid supply from pumps, elevating the nozzle, etc.



Iron is unfit material for spraying pumps, sulphate of copper destroying the nice adjustment of the working parts. So far, brass has given most satisfaction, and all working parts and all valves in contact with the spraying material should be of that or other non-corrosive material. Soft brass, composed of copper and zinc, should be avoided, as it is corroded by ammonia. Leather valves soon become hard and unyielding. All parts should be strong and easily reached for repairs, replacement, or cleaning.

As nearly as possible, all power expended should be applied in forcing the material, in hand work especially. Some pumps, intended to be mounted on a barrel, are so constructed as to make the whole apparatus top-heavy and liable to accidents. It often happens that too much suction is also required to bring the liquid into the cylinder, whereas nearly all the work of the piston ought to be expended in forcing it. The cylinder is best at the bottom of

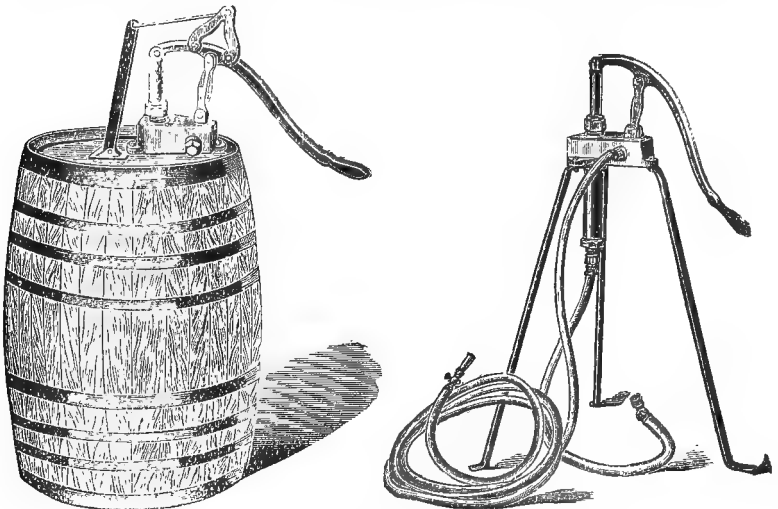

Nixon's Climax Pump on Barrel and on Tripod.

the barrel, immersed in the liquid, where there is little or no suction until the barrel is nearly empty, the liquid itself doing the office of packing, instead of rubber, candle-wicking, leather, etc.

The automatic stirring apparatus should be so perfect that the last spray that leaves the nozzle is as strong and no stronger than the first. Paddles worked by means of the handles, causing up and down currents, involves less loss of power than when a portion of the liquid returns from the pump to the barrel.

Keep trash, leaves, and sticks out of the barrel by means of a rod. The supply pipe leading from the pump should be provided with a quick-acting valve, so as not to cause loss of spray when

not in use, and for facilitating the removal of any clogging of nozzles set without loss of time, waste of material, and deluging the workmen.

The hose should be strong,  $\frac{1}{2}$ -inch inside, three or four ply and of good quality. A smaller diameter would cause too much friction a larger one would make the hose very heavy when full of material. With Power sprayers have plenty of length of hose, about 30 feet. The hose should be well washed, especially after using oil sprays. It is a source of annoyance that universal gauge threads for the interchange of fittings are not used by all makers, as in the case of microscopes.

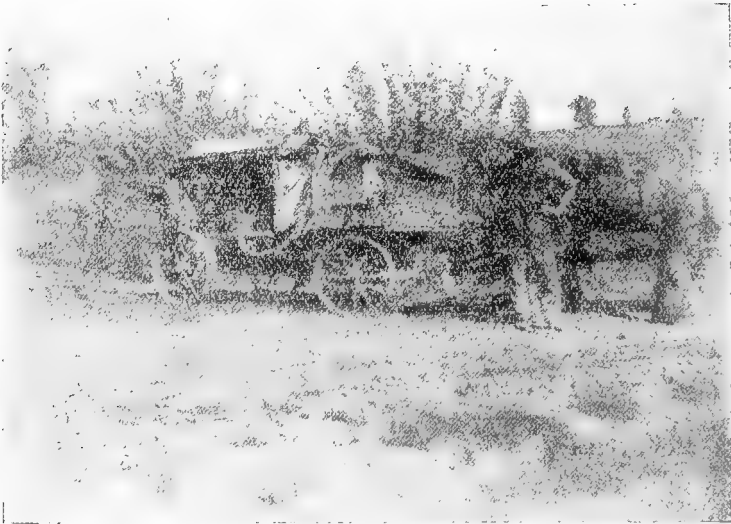

Power Sprayer.

The selection of *Nozzles* depend on the pressure exerted by the pump. The Vermorel type of nozzle used in connection with the knapsack which displays a pressure of 50 to 75lbs. to the square inch, is very satisfactory. They deliver the spray in the form of a cone and give a fine spray even with a low pressure.

In general the higher the pressure the more efficient the spraying that may be done with any form of nozzle.

The Bordeaux type of nozzles which give a fan-shaped spray, are better suited for Power Pumps working under a pressure of 100lbs. to the square inch and over.

#### DUST SPRAYERS.

Mechanical ingenuity has devised appliances for the even distribution of impalpable powders as well as for the spraying of liquids; amongst these is the machine here illustrated.

A strong blast of air is created by moving the lever which carries the powder through a piece of indiarubber piping, terminated by a tin tube, 3ft. in length or more, and having at its end a flattened circular piece of tin. The blast, after impact on the piece of tin, spreads out in a fan-like shape, and distributes the sulphur or powder evenly in the form of a cloud. The machine, which once cost 30 francs in France, is easily kept in working order, all that is required is, besides emptying the reservoir after using, an occasional oiling of such parts of the lever where friction occurs.

This sulphurer distributes fungicide or insecticide powders more evenly and in a finer state than the ordinary bellows.

To produce a similar effect, less powder is distributed over a given area, thus effecting a great economy.

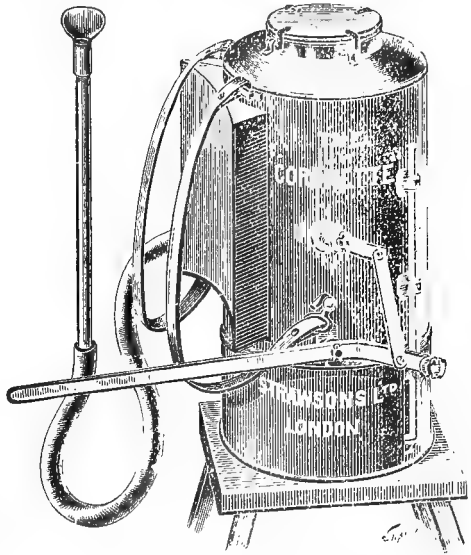

The "Coronette" portable Sprayer.

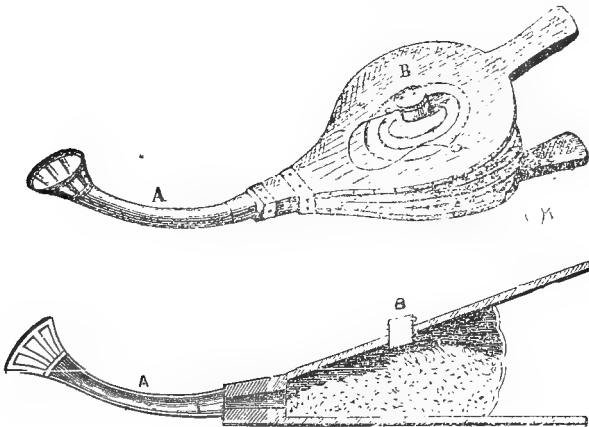

Sulphur Bellows.

The powder is applied with more force, and has a better chance of adhering to all the leaves, while the working is easier than in the case of ordinary bellows.

Simpler and cheaper powder casters are also illustrated, and consist in the old fashioned but efficacious sulphur bellows, the construction of which is shown in the foregoing diagrams.

*Vermorel's Injector for Carbon Bi-sulphide.*—Among the numerous insecticides proposed and experimented upon for destroying the phylloxera and other ground pests, carbon bi-sulphide has been found one of the most reliable as well as efficacious. It is a colourless liquid, heavier than water (1.271 to 15 deg. C.), very volatile (boils at 48 deg. C = 102 deg. F.), and catches fire very rapidly. Workmen using it should, for this reason, carefully refrain from smoking, and avoid carrying matches.

Considerable difficulty was experienced at the beginning in the application of the insecticide round the roots, and in properly regulating its dose, until specially designed forcing pumps came into use, one of the best of which is here shown.

The forcing-pump considered, so far, the best for the purpose of injecting the insecticide liquid into the soil is the one here described, and is manufactured by Vermorel. Its price in France was about 55 francs.

It consists of a copper reservoir, R, holding about a quart of the liquid, which is introduced through the opening, F, closed by means of a screw plug. The piston Y Y, surmounted by the knob, N, works in the pump, A, and is fitted at its extremity with a cup-shaped leather cap, B. A spring, M, drives the piston upwards each time it has been pressed down in injecting the liquid. Underneath the piston, two

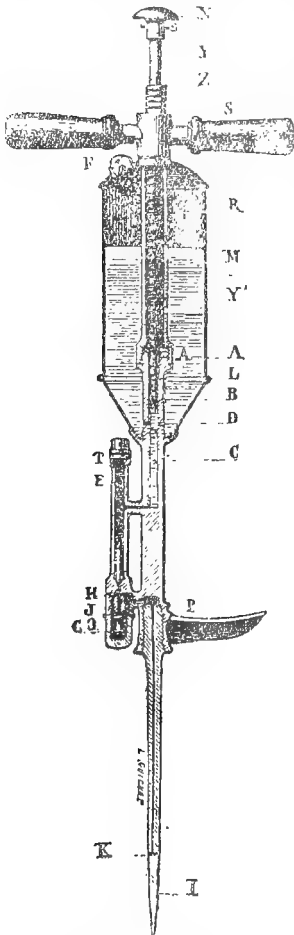

Vermorel's Injector.

small openings, D, place the reservoir in communication with the chamber, T. On pressing the piston down, the bi-sulphide

of carbon is driven into the tube, E, and by pushing a plug, J, fills up the chamber, G, whence it is forced out of the steel needle, I, through the opening K, into the soil.

In order to regulate the dose of bi-sulphide of carbon at each injection, one or more washers, Z, are strung on the piston rod. The pump is so graduated, that each time the piston is pressed down, a dose of 10 grammes (154 grains or  $\frac{1}{2}$ oz.) is injected into the ground. In other words, supposing one injection is made in every square yard: 4,840 square yards multiplied by 10 grammes equals 48·4 kilogrammes, or 95·5lbs., are injected per acre. With one washer or ring added, 9 grammes are injected, or  $\frac{1}{10}$  less; with two rings 8 grammes only are injected; and so on, each additional ring added decreasing the dose by  $\frac{1}{10}$ .

The apparatus having received a charge of bi-sulphide of carbon, is easily thrust into the ground, unless it gets too dry, by pressing on the handles, S, and on the spur P. The knob, N, is then pressed down, and a dose of the liquid injected into the ground. On removing the needle the operator stops the hole left in the soil with his heel, and the volatile insecticide, being thus imprisoned in the soil, diffuses through it, penetrates every cleft and rent, and reaches the enemy, which it soon suffocates. The eggs, however, are not destroyed, and a fresh application after hatching, and within a fortnight, has to be made to entirely rid the ground of the pest.

According to the degree of intensity of the invasion, one or two injections per square yard are made, or, in other words, the knob of the piston is pressed down two or three times.

Between the lines the steel needle is thrust in full length into the ground, viz., 8 to 10 inches, but nearer to the stocks half that depth is sufficient.

Bi-sulphide of carbon is used with best advantage in porous soils, whilst on heavy clays, or in shallow soils with a clay subsoil, at a depth of 10 or 12 inches, its application is not attended with the best results, as the insecticide cannot permeate through the mass of the ground, and by being brought into direct contact with the roots proves injurious to the plant.

#### HOW AND WHEN TO SPRAY.

Credit is given for much of the information contained in this chapter to the contributions of Dr. N. A. Cobb, once Pathologist of the Department of Agriculture, Sydney, and published in the *Agricultural Gazette* of N.S.W.

Mature plants wear an armour of dead cells. Those represent the outside skin or cuticle which lines the upper and under surface of the leaves, and afford protection to the more tender cells which underlie them.

When observed under a microscope they are not unlike a thin parchment or small scales of bark. Owing to their presence, wind, rain, sun, or dust have no action on the more delicate internal living cells, which would soon be destroyed by handling or exposure were it not for this natural jacket which covers them.

This jacket or covering is not, however, absolutely continuous, and small microscopic breathing-pores or stomata occur at intervals on the surface.

Let us suppose such a leaf to be attacked by a fungus parasite. If thin shavings of such a diseased leaf were cut by means of a specially made microscopic razor called a "microtome," and one of these thin slices was put under a microscope, we would see a section of the leaf showing on the outer edges one row of scales of the cuticle, disposed somewhat like bricks or tiles, and in the centre a mass of more tender living tissues, disposed somewhat like a close-grained sponge, and through which the sap circulates.

Now in the case of a diseased leaf, we see permeating the living tissue of meshwork of filaments which are the roots of the fungus, and are called mycelial threads, then, emerging through the breathing pores of the plant, slender thread-like stems showing on the surface of the leaf, and on each of these thread-like stems little branches carrying small sacks full of spores or of seeds of the fungus.

Thus we see that a parasitic fungus robs the plant, through its mycelial threads, of the sap and the food which is pumped up by the plant from its roots to the extremity of its branches for the nourishment of its foliage and its fruit. In order to understand the usefulness of spraying with fungicides, we must not lose sight of these facts. The internal cells of the leaf are so delicate that the application to them of a poisonous substance, even though in a very diluted form, would prove injurious. But those internal cells are covered over and protected by the outside layer of thick-walled impermeable cells just mentioned, which would be able to bear the effect of the poison in a stronger form. Of course, it will be understood that a very strong poison would affect these outside cells also, but there is a certain strength of the poison, slightly stronger than would be injurious to delicate cells, than can be applied to them with impunity. It so happens that the cells of fungi are as a rule very delicate, and highly susceptible to the destructive influence of poisons in solution; and, often, such solution as would not be injurious to the outside thick-walled cells of leaves are quite fatal to fungus cells.

Tender leaves are, as a rule, for reasons detailed in the foregoing paragraph, less resistant than older leaves of the same plants; and, again, some sort of trees, such as the peach or the nectarine, having a thinner and more delicate cuticle than the apple or the pear, are sometimes injured by the application of poisonous liquids that would not hurt the more resistant plants.

Again, the facts brought to light here explain why, in a great many cases, several sprayings are necessary for eradicating disease. The application of a remedy will often only destroy that part of the fungus parasite which shows outside, but fresh shoots will soon be pushed out by the mycelial threads which fresh permeate the more delicate internal tissues of the leaf, and soon carry a fresh crop of spores or fungus seeds, unless by timely treatment the parasite is again destroyed.

Many fruit-growers and farmers, however, who have no conception of these facts, are not satisfied unless a remedy costing next to nothing is offered to them, which will in one application destroy the enemy for ever. The mode of attack of the parasite, explained above, will explain how unreasonable such an expectation is; as a remedy that would effect this end at one stroke would probably, at the same time, destroy the tissues of the leaves.

“The application of fungicides does not effect a cure,” says Dr. Cobb, “it only prevents the fungus from fruiting and germinating. That part of the fungus inside the leaf can be killed only by killing the leaf itself.” Hence the advisability of repeated sprayings which weaken the fungus and also protect the plant for a time and until a change in the climatic conditions make a fresh outbreak of the fungus pest less likely.

Many fungicides and insecticides either consist of particles of solid matter in the form of powder as sulphur, or in suspension in water as Paris green, or partly in suspension and partly in solution as carbonate of copper in Bordeaux mixture. After a plant has been sprayed with one of these substances, therefore, it may be considered as being covered with an armour of solid poisonous substance, which will destroy by contact any fungus shoot that shows on the leaf, or prevents its germination.

All armours, however, have their weak points, and the armour in which we thus dress our plants is no exception. Let us examine, says Dr. Cobb, into the weak points of our system of spraying, and see whether they are capable of being remedied. It requires no very lengthened experience in spraying to learn that different crops receive a spray in very different ways. The leaves of some crops may wet easily, but to one crop of this sort there are many that do not do so. Often the spray will be seen to collect immediately in drops, in spite of its fineness when applied. This is due to the waxy covering with which many kinds of leaves and fruits are furnished. When the microscopic liquid particles, of which the fungicide is composed, come into contact with the bloom of the leaf, they refuse to adhere if the spraying is carried on too long, or they adhere so slightly that the attraction which adjacent particles have for each other comes into play, and causes them to roll up into drops of visible size (Fig. B.)

The illustration shows two patches of wheat-leaves sprayed with the fungicide known as ammonia-carbonate of copper—that is, carbonate of copper dissolved in dilute ammonia. After a plant has been sprayed with this solution, the diluted ammonia evaporates and leaves the carbonate of copper in the shape of an exceedingly fine powder. Consequently, when we examine the surface of the sprayed plant with the microscope, we instantly notice this deposit distributed in patches, as shown in the adjacent illustration. Each patch of deposit is a dried-up droplet of the spray; about twenty such patches are shown in one illustration. Between the patches is seen that part of the wheat-leaf which was not hit by the spray. As long as the patches of poison remain they constitute a protection against the infection by means of spores, which may fall upon a sprayed leaf. A spore falling upon the poison will be killed as soon as it attempts to germinate. Even should it fall upon a portion of the leaf where there is no poison, growth may yet be prevented, as will be readily understood by examining the illustration, where the germination of spores *c*, *d*, *e*, and *f* has been checked, because their sprouts have run against the poison

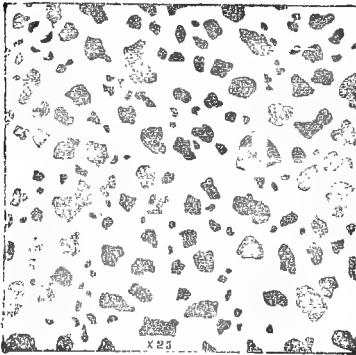

Fig. A.

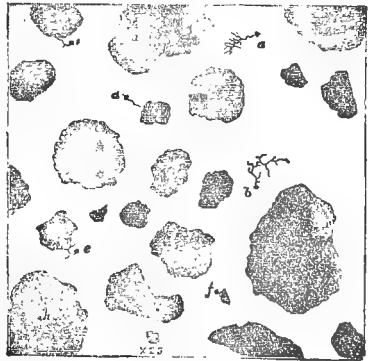

Fig. B.

In the above illustration a careful drawing is given of two different sprayings. In one case the leaf was sprayed for nine consecutive seconds; in the other case, also for nine seconds, but at three different times of three seconds each, the leaf having dried between times. The results are very different. Where the spray was applied nine seconds continuously the drops have melted into one another, and left wide unprotected blanks amongst them (B). It is evident therefore, that Fig. A represents a more efficient method of spraying than B, not because more poison has been applied, but because it is in a finer state of sub-division. It will be seen at once that if the spores *a*, *b*, *c*, *d*, *e*, *f*, *g*, *h* had fallen on A instead of B their chance of growing would have been much diminished.



As it was, all but two spores were killed. These two (*a* and *b*), having alighted in the midst of large areas free from poison, were able to grow to their full extent.

#### FACTS WORTH KNOWING.

The moral of this teaching, is therefore, never spray until the drops of the poisonous liquid drip down from the foliage; but spray rapidly, coming back on your steps spraying again rapidly, and again once more, allowing time for the liquid to evaporate in the interval. No more liquid will be used in spraying the area of ground to be protected by this method, whilst the time employed in spraying will be practically the same in each case, while the result will be widely different.

Two or three sprayings, at a fortnight's interval, are better than only one, and one spraying better than none. Spraying early in the season is much more efficacious than later.

Trees will sometimes be injured by being sprayed on a very hot and windy day; the best time to spray is either on a dull day, early in the morning, or, better still, towards the evening. If necessary, spray at any time except at blossoming time, and within three or four weeks of the fruit being sufficiently ripe for gathering.

Arsenical and copper mixtures are poisonous, and operators should therefore be particularly careful that the spray does not accidentally get carried over to themselves or their assistants. Other sprays are not poisonous, but offensive; and those using them will instinctively keep clear of them.

Whenever the spray pump has been used, and before it is put away for use next day or on a future occasion, it should be emptied, and scrupulously cleaned by running fresh water through it. The suction and delivery hose are unscrewed and drained. After drying the pump as far as possible, it should be carefully oiled, with neatsfoot oil preferably; kerosene oil is not so good; while vegetable oil is least to be recommended. A spray pump or a sulphurer well looked after will last for many years, and do the work most efficiently.

Never keep copper mixtures and solution standing in iron tanks, as it corrodes the iron, but use copper or wooden vessels.

Kerosene, carbon bi-sulphide, and mineral oils will perish india-rubber.

Keep the Paris green locked up, as it is poisonous; the same caution will apply to the other chemicals, generally speaking.

Be ready and begin early.

#### PLANT FUMIGATION.

The fumigation of trees by means of hydrocyanic acid gas was more popular a few years ago. Its operation requires some skill and experience as the gas is one of a highly dangerous character. It destroys friends and foes alike, and on that score does as much

harm as good—unless periodically repeated. Fumigation by means of hydrocyanic acid gas was much boomed in America some years ago but is now less frequently resorted to.

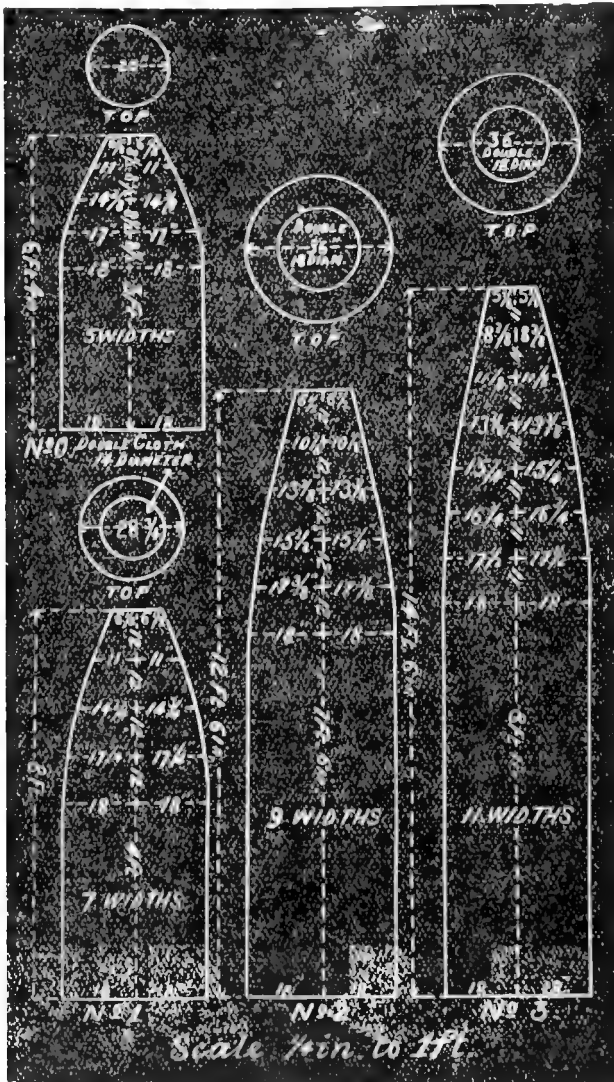

Sketches of Bell Tents.

The success of the operation and its safety to the operators depend on the methods in which this fumigation is carried out.

As very little is known about these methods by fruit growers, a few directions will prove useful, together with more detailed information regarding the process of fumigation and the making and handling of the gas-tight tents.

#### WHAT AND WHEN TO FUMIGATE.

Fumigation by means of hydrocyanic or prussic acid gas is successfully used in the treatment of insect pests ; it has little or no effect on blights of fungoid origin. Insects which can be more readily attacked are scales, red spider, mites, and aphides. Trees and plants can be fumigated at any season of the year. In the winter time deciduous trees can, without injury, be fumigated at any time of the day ; they can also, when dormant, stand heavier doses of gas, as well as a longer period under the tent. Citrus trees require more careful treatment, and should only be fumigated on dull mornings or afternoons, or in the evening by moonlight.

In the summer, when the trees are of active growth, they should only be fumigated late in the afternoon or at night.

The above sketches of bell tents Nos. 0, 1, 2, and 3, show dimensions for cutting widths and tops. One inch is the width allowed for all seams. All measurements are given in feet and inches. No. 0 covers trees  $4\frac{1}{2}$  feet diameter by 5 feet high ; No. 1 covers trees  $6\frac{1}{2}$  feet diameter by 7 feet high ; No. 2 covers trees 8 feet diameter by 11 feet high ; No. 3 covers trees  $10\frac{1}{2}$  feet diameter by 12 feet high. This diagram is taken from Mr. A. Benson's paper in the *Queensland Agricultural Journal*.

#### CAUTION TO OPERATORS.

Those using the process of fumigation for the treatment of scaly trees should bear in mind that they are handling, probably, the most insidious and deadly of poisons.

The gas inhaled in a close chamber produces sudden death ; when largely diluted with air it is harmless. Thousands of thousands of trees are now-a-days fumigated every year, and accidents are rare. With proper precautions there is no danger whatever.

Unless handling small tents covering trees 5ft. or 6ft. high, not less than two men should operate.

Not only is the hydrocyanic acid gas highly poisonous, but the ingredients or chemicals used in its production are also dangerous poisons. These ingredients are : 1° potassium-cyanide, of which a piece of the size of a grain of wheat would prove fatal to an adult or an animal ; 2° sulphuric acid or oil of vitriol, which is eminently corrosive, and every precaution should be taken to guard against its spurting on the face, hands, or clothes.

When operating, hold your breath when dropping the cyanide into the acid, and also when removing the tent and uncovering the tree. See that the tents are always gas tight. Should the acid accidentally spurt on your hands or face, wash at once in water.

Do not handle a clean tree after having examined a diseased one, without previously washing your hands, as the eggs and larvæ of some of the scales are so small that they are easily carried from one tree to another by the growers themselves, or their men. I have often seen people crush scale insects on branches of trees, between their fingers, and then go to the adjoining tree and carelessly handle it and examine it for scale. Trees infested with the San Jose and the more dangerous sorts of scales should not be handled unless it is found necessary to do so.

#### FUMIGATING OUTFIT

consists of gas-tight tents made of light, strong canvas, cut and sewn together in a bell shape, and painted with raw linseed oil. A little turpentine added to the oil will cause it to dry quicker. When painting, spread the tent well by hanging it to the rafters of a shed or the branches of a tree, and leave it to dry thus spread out, lest the tissue of the canvas should heat and rot. Calico is rather a light material for the manufacture of tents; it wears badly, and requires constant patching up. Eight-ounce duck or ordinary blue or brown drilling, sewed carefully, are good materials. It is advisable to have rings at the sides and top of the tent, to ease it over trees by means of a light pole with a fork at the end. A light  $\frac{3}{4}$ -inch gas piping hoop, rung through rings at the base of the bell-shaped tent, is found convenient for covering and uncovering trees, and for keeping the tent stretched out. At the base of the tent, and below the ring, a gas-tight flange or canvas collar, about a foot wide, is provided, and rests on the ground. After the tent has been charged this canvas collar is slightly banked up all round with earth, to prevent the gas escaping.

Before fumigating, inspect the tents. No hole, however small, should be allowed to go unpatched.

Trees too large to be covered with a tent may be fumigated under a large gas-tight canvas sheet.

Also provide yourself with :

- 1st. A common earthenware basin, 6 to 9 inches wide, according to size of tent or tree.
- 2nd. Scales for weighing the cyanide of potassium.
- 3rd. A graduated glass for measuring the fluid ounces of sulphuric acid and of water.
- 4th. If a gas-piping ring is not provided to keep the tent spread out at the base, have an 18ft. light pole, with rope and pulley, to hoist the larger tents over the trees.
- 5th. Sufficient number of 1oz. packets of cyanide of potassium, 98 per cent. purity, which must be kept in an air-tight jar.
- 6th. Sulphuric acid in a bottle with a glass stopper.
- 7th. Water.

## HOW TO RECKON CUBIC CAPACITY.

Consider the covered tree as a cylinder. To calculate its volume, multiply half the width by itself, then by the height; then multiply by 3, or, to be more accurate, by  $3\frac{1}{7}$ . This is expressed by the formula  $V = \pi R^2 H$ .  $\pi = 3.14$ ;  $R$  is the radius of the circumference;  $H$  the height. Thus a tree eight feet wide by eight high would be  $4 \times 4 \times 8 \times 3 = 384$  cubic feet, or say 400 cubic feet. Cyanide of potassium,  $1\frac{1}{2}$  oz. per 100 cubic feet, would be 6 ozs., half as much again, or 9 ozs. of sulphuric acid, with half as much again of water as acid, or  $13\frac{1}{2}$  ozs., making a total of  $28\frac{1}{2}$  ozs., or 7 ozs. of the combined chemicals for every 100 cubic feet.

## DOSES AND TIME.

Cyanide of potassium, 98 per cent. purity, 1 oz. per 100 cubic feet.

Sulphuric acid of commerce,  $1\frac{1}{2}$  fluid oz. per 100 cubic feet.

Water,  $2\frac{1}{2}$  fluid oz. per 100 cubic feet.

NOTE.—If fumigating in the winter for the more resistant scales, and particularly San Jose scale, the doses might be increased to: Cyanide of potassium,  $1\frac{1}{2}$  oz.; sulphuric acid,  $2\frac{1}{2}$  fluid oz.; and water,  $3\frac{1}{2}$  fluid oz. per 100 cubic feet.

The tree having been covered, one operator lifts the bottom of the tent: the other, after having poured in the earthenware bowl the quantity of water and acid (N.B.—Pour the acid slowly into the water to prevent spurting), crawls underneath and places that bowl under the tent close to the trunk of the tree, but not touching it. Then at arm's length he breaks the paper cover of the cyanide of potassium and drops the number of packets required into the bowl holding his breath meanwhile and crawling back; the tent is then let down, earth heaped up on the circular canvas collar, and the tent allowed to remain on the tree 45 to 60 minutes. Much of the poor work sometimes done is to be attributed to insufficient time.

N.B.—The mere fact of covering a tree in full growth by means of an air-tight tent, for an hour or two, while the sun is up and the plant breathing, is enough to choke it and cause it to drop its foliage; therefore, be careful to only fumigate, if in the growing months, in the cool of the evening or early in the morning. If the tree is dripping wet or is covered with beads of dew injury to the foliage might result.

When the time is over, the operator and his assistant uncover the tree by lifting the tent up, holding their breath while so doing, when another tree can be covered and treated without pausing.

Should a battery of half a dozen tents be in use, a considerable number of trees can be fumigated at once and without waste of time.

Bury the residue left in the bowl after fumigation.

## NURSERY STOCK AND FUMIGATION.

Every nurseryman now finds a fumigatorium as necessary a part of his equipment as seeds, buds, and grafts.

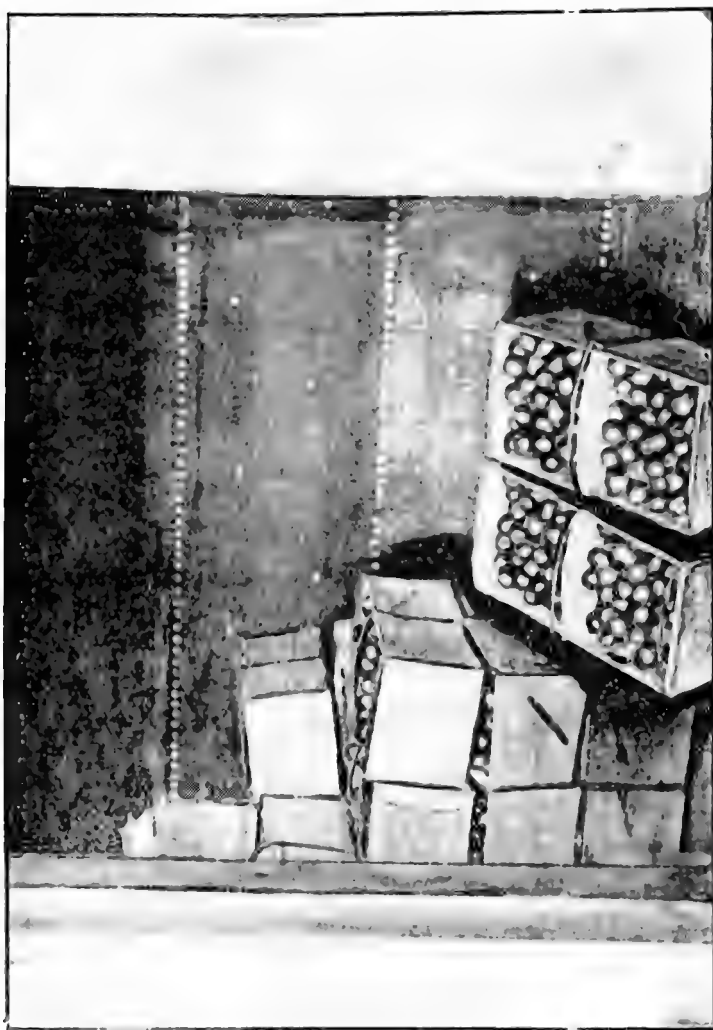

Fumigation Chamber for Imported Nursery Stock and Fruit—Fremantle.

The young trees should be subjected to fumigation before being distributed far and wide, as hydrocyanic gas is the only satisfactory and inexpensive method known at present for the destruction of such persistent pests as the San Jose scale, while, when properly

handled, it has no injurious effect on the stock. The fumigating chambers may be made of any convenient size or material, the essential point being that it shall be capable of being closed absolutely air tight, and provided with a flue-pipe in the roof, which can be opened or closed to allow of the escape of the gas after fumigation. The flue should be provided with a box containing caustic potash or soda to destroy the gas. The door of the chamber is provided with a shutter or sliding panel at the lower portion.

The trees having been placed on the floor of the fumigatorium, the cyanide of potassium, water, and sulphuric acid are brought together as explained above. At the end of an hour the shutters in the flue and in the door are opened, and the draught produced causes the gas to escape. After 10 to 15 minutes the door may be opened, but no one should be allowed into the chamber for another space of 10 minutes.

With ordinary care, no accident need be apprehended.

#### FUMIGATING GRANARIES.

The same method of ridding granaries, flour mills, and barns of weevils, moths, and other troublesome insect pests, without removing the grain stored in the buildings, can be carried out wherever the building can be made gas-tight. If the fumigation is done under the conditions already detailed, the seeds will retain their vitality almost unimpaired, if dry when subjected to the fumes.

#### FUNGUS DISEASES.

##### APPLES, PEARS, AND QUINCES.

**BITTER PIT.**—Apples apparently sound soon develop, on keeping, unsightly spots, which make them unmarketable. This is, next to black spot or apple scab, the worst fungus disease of the apple.

The disease shows sunken brown spots, as if the fruit had been trodden on with nailed boots. When the apple is cut there are, below the spots, pieces of brown spongy tissue, bitterish to the taste, sometimes extending to the core. Dr. Cobb, D. McAlpine, Masset, the mycologist at the Royal Gardens, Kew, and other vegetable pathologists, have seen no evidence that would prove the disease to be caused by a fungus. Some

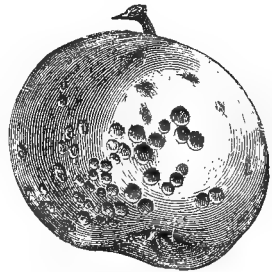

Bitter Pit.

authorities say it is probably caused by a micrococcus, but the disease is not contagious. There is no effective remedy, except to avoid soils liable to this disease in localities where it is troublesome. Nurserymen should be very careful against using scions from diseased trees. Cleopatra, Rymer, Esopus, Spitzenberg, and

Scarlet Nonpariel, amongst the better sorts, are most liable to this disease. Among the less affected commercial kinds are Jonathan and Yates. McAlpine expresses the opinion that it is caused by defective nutrition, and that nitrogenous manures aggravate it, and suggests correcting this tendency by a more liberal use of potash and of lime, especially gypsum. In Western Australia as well as other countries where bitter pit is troublesome, trees badly affected in damp localities on the plains hardly ever show the disease on well drained soils and on the gravelly slopes of the Darling Ranges. Pick and burn all diseased fruit.

**BITTER ROT OR RIPE ROT** (*Glæosporium versicolor*, Berk).—Attacks ripe apples, pears, grapes, tomatoes, and peaches. Appears about the time the fruit begins to ripen; the first symptoms are small circular brown spots, which rapidly enlarge and assume various shades of brown, in concentric rings. After four or five days small postules appear on the brown spots. These burst when the spot has become a little larger, and give exit to a light salmon-coloured mass composed of the spores of the disease. This goes on the diseased spots, throwing up ring after ring of postules until the whole apple, within a fortnight, becomes rotten.

The disease is often noticed in the storeroom; it does not attack all varieties of apples with equal virulence; many of the culls in packed fruit are due to this fungus.

*Remedies.*—Carefully pick up and destroy every rotten fruit in the orchard; do not throw diseased fruit into the pig-sty, but burn it. Prevention is the only practical way of combating this disease; drain the land if necessary, spray in winter with strong winter spray. Spray the fruit until late in the season with ammonical carbonate of copper, or with potassium sulphide ( $\frac{1}{2}$  oz. to gallon of water).

**BLACK SPOT OR SCAB** (*Fusicladium dendriticum*, Eckl.).

**APPLE OR PEAR BLIGHT OR SCAB** (*Fusicladium dendriticum*, Eckl.).—A common disease in moist climates. "The losses sustained from its attacks (says Dr. Cobb) vary from 10 to 90 per cent. of the crop." For about a month after the fruit sets, the scab plays great havoc in orchards where it is abundant. It is easily recognised. Dark velvety green patches turning to brown or blackish scab-like spots appear on the leaves and fruit, arresting growth and causing the parts to become distorted. The outlines of the spots are rounded at first and become more angular as they increase.



Pear Scab (*F. pyrinum*).



Closely allied to the fungus which causes pear-scab. (*F. pyrinum*).

Some affected trees blossom most profusely, and hardly ever set their fruit, or else, if these set and grow they often split and crack.



Apple Scab (*Fusicladium dendriticum*, Eckl.)

*Remedies.*—Preventive remedies are the best. Destroy affected leaves and worthless fruit by fire or otherwise. The disease winters partly in fallen diseased leaves where the spores or *conidia* develop into a higher or more complex form of fruit in which the *sporidia* or reproductive bodies are produced within *asci* and in the spring germinate and infect new leaves. Spray affected trees with Bor-

deaux or Burgundy mixture late in the winter, after pruning. Again, at half-strength, while the leaves are appearing and as the blossoms begin to unfold from the buds, and again as the blossoms fall, and fourthly, when the fruit is the size of marbles. At that time 1 oz. of Paris green in 12 gallons of the Bordeaux mixture will hold the codlin moth in check where this troublesome insect has established itself. It is important that the early spraying should be made as directed. In bad cases an extra spraying is given a few weeks after the one given whilst the blossoms are falling. Do not neglect the trees during an "off" year because there is little fruit, the spores living and thriving on branches and leaves as well, will cause great loss the following season.

The following illustration tells graphically the result of spraying pear trees to protect them from scab disease:—



Pear Trees affected with Scab, Sprayed and Unsprayed (*U.S.A. Year Book*).

**BARK BROWNING.**—G. Masee describes on young apples, plums, peaches, and other species of rosaceous plants a bark trouble caused by a fungus *Eutypella prunastri*. The first outward indication is a slight browning of the stem bark which soon becomes hard, dry, and inseparable from the wood. As time goes the mycelium continues to grow inward, killing the cambium or growing wood, thus preventing the upward flow of sap. The second season the leaf buds either do not expand at all or imperfectly and during the summer the branches die through a lack of food. Minute transverse cracks are then seen on the dead bark; these contain small clusters of the fruiting organs of the fungus; there is no other outward appearance and the tree is often believed to have been killed by drought or some attack on the roots.

Infection takes place through punctures caused by insects, and through the cut ends of twigs. The spores mature in the Spring and it is recommended not to prune during that time. In the case of infected trees the wounds made by pruning should be coated with tar or some other substance. Insects, especially aphides should be held in check. See "Canker" below—a somewhat similar trouble.

**BROWN ROT OF FRUIT** (*Monilia fructigena*, Pers.).—Attacks apples, plums, cherries, peaches, almonds, and other kinds of orchard fruit. It is caused by a fungus which produces its spores in chains, and hence called *Monilia fructigena*.

Although more frequently observed on the fruit, it occurs also on the young shoots, leaves, and even the flowers.

On the leaves in the spring, it shows as thin, velvety, olive-brown patches, consisting of barrel-shaped spores, originating from mycelium present in the tissues of the leaf.

At maturity the spores are carried by rain, wind, insects, birds, and on the surface of healthy fruit. Of these the disease first shows as brownish scattered patches on the skin. The fruit attacked does not readily rot, but dries up and remains in a mummified condition through the winter, either on the ground or on the tree. From these, innumerable blackish sclerotia, or storage organs, bearing in the spring a crop of spores, renew the infection.

This disease is, in places, the worst the plum-growers have to deal with.

The remedy consists in picking, removing, and burning all these mummified fruit. Spray thoroughly before the buds burst. Suppress bark and skin-nibbling insects in the spring. Spray with Bordeaux mixture when the fruit is forming.

**CANKER** is first caused by a bruise or a laceration of the bark of the branch, and the invasion of the wound by a fungus (*Nectria* and other fungi), which prevents a healthy healing up of the damaged tissues. The claws of climbing animals, the bite of gnawing insects, and other causes bring about this trouble.

*Remedies.*—Remove the cause of canker. If the bark is never wounded, canker will never appear. Prune the diseased branches and burn the cankered parts. Lime, sulphur, and salt wash.

Canker can also be cured by paring off the bruised, ulcerated wounds, and then covering the diseased parts with a paste made of clay mixed with hydrochloric acid. Painting the affected part with the acid used by tinsmiths under the name of "spirits of salts" is also a simple and efficacious remedy, the acid destroying the fungus of the canker without damaging the tree. Handle the acid carefully, as, if splashed on the clothes, it will burn holes in them.

**MOSS OR LICHENS.**—Any of the winter sprays will clean affected stems and branches.

**MOULDY CORE.**—A diseased condition brought about by the presence of common mould in the core of certain varieties of apples, generally by the fungus of brown rot, the infection starting from the centre instead of from the circumference. Outwardly such apples appear quite sound, but on cutting them in halves the core is found to be in a mouldy or half-rotten state. Sooner or later the whole apple becomes rotten, the rot working from the centre outward. The mould gains entrance to the core of the apple through the eye; those varieties with an open blossom end being more subject to the disease. Those varieties of apples with large open pip-holes (concludes Dr. Cobb) are not likely to prove good keepers.

**CRINKLE, OR PIG FACE.**—An obscure disease of the apple. Mr. McAlpine says of this disease:—"Besides the recognised Bitter Pit, which causes small brown depressions on the surface, another appearance was noticed, particularly in Rome Beauty and Five Crown Pippin. The skin is apparently quite sound, but a little darker towards the eye end, and, if cut across, brown, dead tissue is found immediately beneath the skin, or between the skin and the core. There may be actual cavities in the decaying flesh; and the diseased patches do not taste bitter. Although many varieties not subject to Bitter Pit, exhibit the Crinkle disease, it is probably likewise due to disordered nutrition. The upper end of the apple ripens first, and if, from any cause, a proper supply of nourishment fails to reach it, there would be decay, and ultimate death of the cells. I have given the common name of "Crinkle" to this disorder, because the upper surface of the fruit is thrown into rough folds, giving it usually, an uneven and crinkled appearance."

Treatment of the soil reduces the trouble as is the case with Bitter Pit; applications of lime, especially in the form of Thomas' Phosphate or of gas lime has proved satisfactory, particularly with Potash and Phosphates added. Nitrogenous manures seem to aggravate the disease.

**TWIG BLIGHT.**—Small, stunted rosettes of leaves grow in the spring on the previous year's wood, and fail to grow into healthy shoots. Later, in the early summer, strong shoots spring up from

the base of the limbs instead of from the extremity. No pustules are noticeable on the leaves, which have an unhealthy appearance. This serious trouble which is still under observation, has been found associated with two causes, either independently or concurrently.

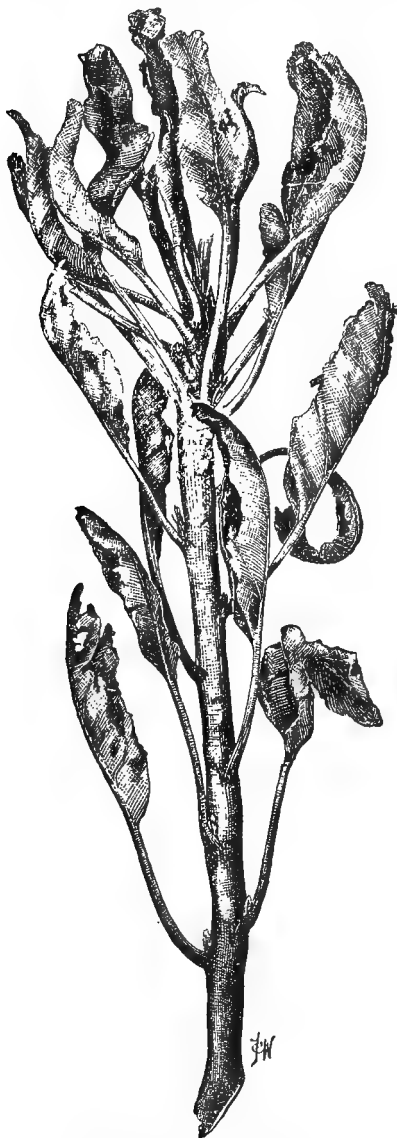

Powdery Mildew of the Apple.

The one a bacterium (*Bacillus amylovorus*, Burr). which, in the old cases of blight, winters over in the blighted parts. From these diseased parts a watery exudation at times takes place in the spring which is visited by insects, and by them transmitted to the opening blossoms or to the sap vessels of the tree. Once within the tissues of the host, the microbe may spread indefinitely.

Another cause producing a similar appearance, has been traced to the presence in the ground of a mould which grows on the surface roots and spreads over them web fashion, thwarting their growth, with the results described.

In the first instance, spraying early to keep off inoculating insects, confines the trouble to a few trees only, and may also disinfect the infested exudation. All blighted parts should be carefully cut off below the lowest manifestation, and burnt each autumn. A good precaution is to disinfect the knife, after cutting through a diseased spot by dipping in carbolic acid.

Cultivate thoroughly and fertilise liberally, to help the trees to throw off the disease. Drain where required.

In the second instance, the ground should be deeply ploughed, thoroughly drained, and liberally limed and manured, so as to encourage the growth of the roots in healthy surroundings. (See Pear Blight.)

In every case examine the subsoil. In many cases the ground is unsuited for the healthy growth of fruit trees and is not such as will carry a commercial orchard. A hard pan of impervious clay or of cement ground would prevent the roots dipping down in search of nourishment and would become water logged and stop root development. In other cases a layer of coarse sand or gravel underneath is interposed between the dry surface and the moister subsoil, and prevents the rise of the moisture from below; in other cases again, the rise of the bottom water impregnated with saline matters check root growth and starves the tree.

**WATER CORE.**—Easily known by the watery or waxy appearance of either the whole or part of an apple. The apple is quite sound to outward appearance. More prevalent in moist seasons, especially in early sorts. Winter varieties are comparatively free from it. Stone Pippin and Five Crown Pippin are somewhat subject to it, also seen in Rokewood.

It is also noticed in dry districts, but to a lesser degree. The glassy palities are due to the exclusion of air amongst the cells of fruit and its replacement by sap. If the soil and the subsoil are guarded against extremes of dry or wet by drainage, irrigation or cultivation, the trouble is readily kept down.

**POWDERY MILDEW OF THE APPLE, PEAR, AND QUINCE** (*Podosphaera Kunzei*, Lev.), sometimes called "fire blight." Very destructive to nursery stock. Attacks the apple, peach, quince, cherry, and other plants belonging to the *Rosaceæ*. It attacks mostly the young leaves, spreading over both surfaces, and showing like white felt. Spray with Bordeaux mixture or with Iron sulphide spray (V. No. 15). In summer time, sulphur the trees. Cleopatra and Stone Pippin appear to be especially liable.

**PEAR BLIGHT, OR FIRE BLIGHT** (see Twig Blight, p. 552).—A bacterial disease which attacks apples, pears, quinces, loquats, and other trees. It works in the tissues between the bark and the growing wood, only during the growing season.

Some varieties of pears, like the Duchess and Kieffer's Hybrid, resist the disease better than others, such as Bartlett and Clapp's Favourite.

The blight microbe *Bacillus amylovorus*, is greatly influenced by climatic conditions; warm and moist weather, with frequent showers, favouring it. These conditions are prevalent in the month or two following blossoming time. Dry, cool, and sunny weather hinders it, while very dry weather checks it; and it remains dormant during the winter. The line of demarkation between healthy and diseased wood is then often quite marked.

In the spring, when sap pressure runs through the tree, the blighted parts are recognised by the moist and fresh appearance of the bark, as contrasted with the old and dry bark of the previous summer. The gum exudes from various points, and runs down the tree in long lines, when bees and other insects which are attracted by it carry the microbes to the blossoms, where they gain an easy entrance into the healthy tissues under the bark. These blossoms soon wither and die. Tender twigs are often inoculated by nibbling insects, and show signs of the blight. An observer in California relates a successful check consisting in the case of infested trees of slitting the bark clear round the tree once, a day or two before blossoming—a wide girdle might injure the tree. This stops the flow of sap for a day or two and causes the blossoms to wither and fall off, thus the bees are unable to carry the infection from those blossoms. Infested branches are also cut and burnt. This destroys the fruit crop for a year or if renewed for two, but after a few years the disease runs its course, loses its virulence and dies out and the trees recover.

Some observers contend that because the microbe flourishes best in tender tissues, anything which tends to luxuriant growth of the tree, such as pruning, manuring, cultivating, are to be deprecated; and they advise leaving it to the trees to fight their own battles. If this be the correct treatment, it is time, labour, and money wasted to grow apples, pears, and quinces in those places where the disease is prevalent, as stunted, hungry trees are even less profitable than blighted ones.

Little is known as yet concerning the best means of combating this bacterial disease. Until the results of well planned out experiments have proved the contrary, I would recommend deep and good cultivation, and fertilising with gypsum, potassic and phosphatic fertilisers, efficient deep drainage, carefully cutting off all diseased branches and twigs, and burning them in the winter, care being taken to cut into healthy wood and to disinfect the secretion on the knife after going over a diseased tree. Lastly—and I believe that much good can then be done in checking the spread of the fire blight—spraying the diseased trees at frequent intervals with an antiseptic solution in the spring, during that period when the infected sap oozes through the bark, and is taken up and carried about by foraging insects.

Amongst the sprays which are likely to be attended with good results, I would recommend a two per thousand solution of corrosive sublimate, or a weak carbolic acid solution.

As a vehicle for these powerful disinfectants, a decoction of eucalyptus (blue gum leaves) would probably be found helpful. The leaves should be bruised when freshly gathered, and soaked in tepid water—1lb. of leaves to one gallon of water—then, with the addition of the substances mentioned above, the decoction should

be sprayed on the trees. It is sticky, and adheres quickly. All insects will abandon any foliage where this spray is used.

#### LOQUAT.

**BLACK SPOT** (*Fusicladium eriobotryæ*).—To commercial interchange with the Eastern States we owe another disease of our orchard trees. The loquat, until lately, was, almost without exception, raised from seeds from locally-grown fruit, and the plants were healthy. Whether the disease was introduced by imported fruit or on nursery stock, it is not easy to determine. This blight is caused by a fungus closely allied to that which produces the scab diseases of apples and pears, and its botanical name is *Fusicladium eriobotryæ*. Diseased loquats were first submitted for identification to this Department in 1898. It has since been spreading, and some years it is reported to do serious damage to the loquat crop in a number of gardens.

The fruit is attacked when half grown, by brownish black spots, which soon extend, stop the further development of the fruit, and disfigure its appearance. Before attacking the fruit, brown spots show on the leaves and assume a darker colour. The fleshy part of the fruit becomes desiccated, and the skin seems to cling to the stones. A large proportion of the crop may, in a short space of time, be rendered absolutely unsaleable.

*Remedy.*—That treatment must be protective, and cannot be curative, as the fruit once spotted can never be freed of the blemish.

Spraying with Bordeaux mixture soon after blossoming, when the petals have fallen, and the fruit has just formed, should be found an effective protection. This treatment should be renewed when the fruit is half grown, in the winter, when the weather is likely to remain fine for some time. If necessary, a third spraying, a fortnight after, would copperplate the tree against an attack of the fungus.

Collect and burn all diseased fruit, and sweep and burn the leaves as they fall from the tree.

The loquat also suffers from a *bacterial* disease somewhat similar if not identical to that which causes Pear Blight. Infection first takes place through the blossoms. These wilt very quickly after inoculation and are easily detected. Snap off with the hand the entire twig and if signs of disease still show, break further back. If pruning shears are used they must be disinfected after each cut. If the disease reaches the trunk, death of the tree results.

#### STONE FRUIT.

Almonds, apricots, peaches, and nectarines as well as plums and cherries, are attacked by fungus diseases which, if not in every instance identical are sufficiently closely related to be described under one heading, and are amenable to similar treatment.



**CURL LEAF** (*Exoascus deformans*, Eckl.).—Sometimes simply called the “curl” owing to the leaves becoming distorted and crumpled, early in the season. After a time a delicate whitish bloom, caused by the spores of the fungus, show on the surface. The young shoots are also at times swollen and distorted by the fungus.

Spring infections of peach leaves are due to spores of the fungus and not to perennial mycelium as formerly held, hence the efficacy of sprays. Treatment one season will not prevent the disease the following year. Orchards in damp situations are more subject to curl leaf than those in dry regions or elevated situations.

When the attack is bad, the trees at times lose their leaves before midsummer, and later on a fresh lot of healthy leaves grow ; but in the meanwhile much damage has been done to the trees.

A single winter spray with Bordeaux or with Burgundy mixture will prevent the disease upon even the most susceptible tree.

Some varieties, such as Flat China, Lovell, Elberta, Royal George peaches are more subject to this disease ; few are wholly free. In the treatment from 95 to 98 per cent. of the spring foliage may be saved by spraying.

An allied disease of the plum, called “Pocket Plums” or “Bladder Plums,” is caused by the fungus *Exoascus pruni*, Eckl., and should be treated in a like manner.

**BROWN ROT.**—This disease is described above. It is caused by a mould or fungus, called *Monilia fructigena*, which attacks various parts of the plant, leaves, blossoms, twigs, and fruit.

**CHLOROSIS** is due to the inability of the plant to take up sufficient amount of iron necessary for the production of chlorophyle. Impaired vitality is the cause and may be brought about by fungoid diseases of the roots or by bad soil conditions leading to an accumulation of deleterious substances such as : too large a proportion of magnesia relatively to lime ; excessive marliness or defective aeration of the soil which may be stiff and clayey, or water logged about the roots, in fact all the conditions found associated with Die Back and the Twig Blight.

Sulphate of iron mixed with the soil, and good manuring have done much good, but the cause must be removed and amended.

**DIE BACK** is often connected with parasitism from the *Armilaria* fungus on the roots which also causes *Pourridie* on the vines (*vide* page 565). On several occasions I have had good results from a liberal dressing of sulphate of iron in the winter, followed by liberal stable manuring with superphosphate added in the spring and good cultivation in the summer months. Die Back is seldom seen on deep loamy soil well provided with humus. See notes in Twig Blight, Fire Blight, and Chlorosis.

**GUMMING, SOUR SAP, OR DIE BACK.**—There are many diseases characterised by a gummy outflow from the diseased parts or from

their neighbourhood. Amongst plants exhibiting this are trees like the mulberry, olive, vine, fig, and vegetables like potatoes, turnips, beetroot, and many others. As yet, however, investigations giving satisfactory explanations of their occurrence are inconclusive. It is, however probable (says Tubeuf) that they are primarily due to errors in cultivation, while the bacteria which are always found associated with them are of secondary importance as disease-producers.

Gumosis or Sour Sap, which are results rather than causes, may probably be traced to an abnormal condition of the soil. Sour Sap when the roots die first, may be due to too much water ; and when the tops die first, to the sudden lowering of the temperature. A checked sap circulation from the stock to the scion may also bring about the trouble. Improperly fed trees, or trees supplied with indigestible (unassimilable) food, are less apt to withstand the attack, and succumb.

The trouble shows in a variety of ways. The young spring shoots suddenly collapse and wither. In that case, cut hard back before the poisonous sap can travel back to the healthy parts. In other instances, the foliage and twigs seem all right, but the fruits, when the size of a walnut, stop growing, turn brown, and show a gummy exudation on dark-coloured patches. A microscopic examination discloses the presence of numerous fungi, often of the *Macrosporium* tribe. A liberal dressing of 5lbs. to 10lbs. of superphosphate of lime in the win'er, with lime added, often saves trees predisposed to gumming. McAlpine attributes the cause in some instances to a fungus: *Clasterosporium carpophilum*. Bordeaux mixture has been found an efficacious treatment when applied in the autumn or early winter, even before pruning ; every bud must be soaked.

A somewhat similar disease, supposed, however, to be of bacterial origin, at times attacks young apricot trees, when two to four years old. It is recognised by the leaves or part of the tree turning yellow and falling off. The limbs from which the leaves fall, when cut through, show a black heart.

Prune these limbs back as far as they show the black heart, and also shorten the limbs that are not diseased. Disinfect the knife after it has come into contact with the diseased sap. (See above.)

**LEAF RUST** (*Uromyces Amygdole*, Cook, and *Puccinia pruni spinosæ*, Pers.).—Very prevalent in damp localities (late in the summer) on peach trees, and also the almond, nectarine, apricot, and plum.

The leaves are picked with yellow spots on the upper surface of the leaf ; these yellow spots are often surrounded with a purplish ring, and they have on the other side of the leaf brown spots of fungoid growth. The leaf tissue attacked by these spots becomes

eaten away into holes, and the leaf falls, beginning from the butt end of the branches, and the wood does not ripen as it should do, thereby enfeebling the tree.

*Remedies.*—Collect and burn all affected leaves and destroy the summer spores, which remain inert during the winter only to infect the next year's growth. Spray early in the season with Copper Mixture, half strength, or other fungicides.

**LEAF SCALD** (*Entomosporium maculatum*, Lev.) attacks the leaves of apples, pears, quinces, peaches, cherries, etc. (says Massee). These fall early in the season, and in bad attacks leave the trees defoliated. A second growth of leaves follows, and at times these suffer in the same way. As a consequence, the trees are much weakened.

Small red spots appear on the upper surface of leaves when still young ; these increase in size and become brown, having one or more minute black spots slightly above the general surface. If the spots are numerous, the leaves become brown, shrivel, and fall off. If the leaf is older, with rigid tissues, it retains its shape, but falls to the ground.

On the branches the spots are at first reddish, becoming slightly sunken with a central elevation and blackish in colour which coalesce, sometimes encircling the branch, in which case, the portion above the diseased area dies.

The fruit of pears is sometimes spotted by the disease.

Bordeaux Mixture keeps the blight in check.



Scab and Peach Freckle.

#### SCAB.

**PEACH FRECKLE** causes dark spots on the skin of maturing fruit, which present a freckled look. These spots are the result of

the attack of fungi, and amongst them the *Cladosporium carpophilum*. Its filments do not enter the peach, but draw their nourishment through the skin. It is said that the disease hastens decay, and that affected fruit will not stand long keeping. An early application of Bordeaux Mixture stops its progress. Potassium sulphide half ounce to the gallon, is also recommended.

ROOT KNOT often shows on peaches, plums, etc. It is caused by a bacterial organism very prevalent in some nurseries to the one which causes the finger and toe disease of beetroot, carrots, etc.

Pare out the excrescences and wash with an antiseptic swab. If it is a young tree and is badly affected, replace by a healthy one.

SHOT HOLE DISEASE (*Phyllosticta circumcissa*) attacks the leaves of apricots, almond, peach, nectarine, and other stone fruit trees. Appears as spots upon the leaves in summer, and these spots assume definite outlines, and often fall out, leaving holes like shot-holes. The leaves fall early, preventing the fruit from maturing. These are also attacked, and at times disfigured.

The accompanying figure illustrates the effect produced by the treatment.



Shot Hole on Apricot. The healthy growth took place since spraying.

*Remedies.*—Burn leaves as soon as they fall. Bordeaux Mixture, half strength, applied several times during the season, beginning as soon as the leaves appear.

#### CITRUS TREES.

Trees of this species are subject to a number of diseases, the most serious of which are—

**GUMMING, COLLAR ROT, MAL DI GOMA.**—A serious contagious disease of stone fruit and citrus trees. (pp. under twig blight and gumming of stone fruit.) It seems to be a cracking in the bark and an exudation of the gum, which runs down the tree and affects the bark underneath. Abrasion of the bark with the hoe, plough, and other field implements, deep planting, defective irrigation, and water standing round the trunk favour the disease; also sun scorch and late cold weather, which hurts the shoots.

The disease is an obscure and serious one, and has not yet been thoroughly investigated. Supposed to be produced by a microscopic fungus (the *Coryneum Beijerinchi*) which develops in the vegetal cells and change into gum the cells which constitute the pith, as well as those of the medullary rays, and sometimes also the woody tissues. In mild cases, recovery has followed the cutting out of the bark and gouging out the dark decayed wood underneath with a half-moon chisel until the sound wood is reached, which is then coated over with shellac paint or some other protective cover, preferably an antiseptic one, such as carbolic acid solution. Burn all diseased bark. Affected trees are profuse bearers for a season or two, and then generally die out. If a spot where the gum is oozing out is cut out in diseased trees, a dark channel is seen underneath, extending generally from the root to the top of the tree, following fibro vascular bundles of wood tissue; this wood is sometimes dry (and so hard that no sap could flow through its vessels) or rotten and decayed. In the majority of cases, the best plan is to root up and burn the tree. It is often propagated by secateurs. Sterilise the blade at frequent intervals in flame.

**MELANOSE** must not be confused with the disease called Rust or Maori. The numerous small madder-brown spots characteristic of this disease have (says Dr. Cobb) a tendency to group themselves in curved lines, which run together and form larger patches. Both Maori (caused by a mite) and Melanose at times occur together on the same orange. The leaves are attacked as well as the fruit.

*Remedies.*—As soon as the new crop has set, begin spraying with Bordeaux Mixture of weak strength, and keep on spraying, if necessary, every fortnight until the fruit is half grown. The addition of a little soap will cause the spray to wet the citrus leaves better. Paint the trunk and limbs with a thin whitewash, or with full strength Bordeaux Mixture. Apply to the ground under each

tree one pound of sulphate of iron in 25 gallons of water ; also give to the ground a dressing of three to four pounds of bonedust and one pound of sulphate of potash per tree, and avoid dry blood or organic nitrogen fertilisers. Make sure that drainage is good.

**BLACK SPOT OF CITRUS FRUIT** (*Phoma citricarpa*, McAlp.)—This disease, known also as anthracnose of citrus fruit, is on the list of prohibited diseases, and fruit showing signs of them are destroyed at the ports of entry.

For the information of growers, and also of the officers in charge of the disinfection sheds at the ports of entry, I reproduce from Mr. D. McAlpine's Monograph of Fungus Diseases of Citrus Trees in Australia, a summary of the description of the disease.

The disease, it is stated, has not been met with in Victoria, but it is quite common on oranges, mandarines, and lemons sold in Melbourne and suburbs, and imported from Sydney.

The fruit is affected by spots, round and sunken, and of a dark brown colour ; at first, whitish or greyish towards the centre, but ultimately becoming of one uniform tint. They are either isolated or run together in confluent brown patches. These are pustules which allow the escape of spores, which may be wafted by the wind, or carried by hands, clothing, insects, animals or empty cases. Thus is the disease rapidly and widely spread. It bears some resemblance to another black disease of citrus fruit called "Melanose," and also to a disease known in Italy as "La Nebbia," which is, however, caused by a different fungus. The effects of the disease on the fruit is that, besides being unsightly and rendered almost unsaleable, they soon become rotten and fall a ready prey to "Blue Mould," etc., so that all such should be rigidly excluded from shipments to distant markets. The fungus is found on still green fruit, and spreads most rapidly when the fruit ripens.

*Treatment.*—The skins of diseased fruits should be burnt, in order to prevent the spores reaching fresh growing fruits. The cases containing diseased fruit should be disinfected by steaming or by dipping in boiling water for a few minutes. Spray the trees with Bordeaux Mixture as soon as the fruit sets, and again every few weeks up to within a month of the time of picking the fruit.

**SOOTY MOULD OR BLACK SMUT.**—Fumagine follows the attacks of aphides and of scale insects, forming a sooty black membrane, which feeds on the sweet fluids (honeydew) secreted by these insects, and which falls on the leaves, branches, and fruits of the last plant they live upon.

The growth of the trees affected is retarded in consequence of light and the respiration of the plant being interfered with. The insects further injure the plant by sucking the nutritious juices from the cells, and blooming and fruiting are, in consequence, checked or suppressed, and the market value of the fruit lowered.

*Remedies.*—Spray two or three times at intervals of one or two weeks in the winter, and after the fruit crop has been picked, with kerosene emulsion or resin and soda wash or fumigate with hydrocyanic acid gas.



Strawberry Leaf Blight (*Sphaerella fragariae*, Tul.).

Better still, collect and procure parasites and predaceous insects on the aphids and the scales, which are the primary cause of the sooty mould. When parasites are present, spraying or fumigation will do more harm than good, and will tend, by destroying the beneficial insects, to intensify the trouble.

**ROTTING OF CITRUS FRUIT.**—Considerable loss is at times experienced during transportation or storage of citrus fruit. The cause is due to one of the blue moulds—*Penicillium digitatum*. This fungus grows on the fruit from a spore, which germinates and penetrates the tissues in the form of white threads, and feeds on the juices; after a time they show outward as a white mould which, when it fructifies, appears like bluish-green dust. The disease occurs more in the fruit store than in the orchard. Sulphur fumigation minimises its spread. It mostly attacks bruised fruit.

**STRAWBERRY LEAF-BLIGHT OR SUN BURN** (*Sphaerella fragariae*, Tul.)—"This is the only serious fungoid disease of the strawberry plant now known in Australia," says Dr. Cobb. It is very widespread, and does a great deal of damage, causing a loss of from five to ninety per cent. of the crop.

Small purple or red spots appearing on the leaves. They eventually become larger and browner, making the leaf appear blotched. The growth of the young berries is also checked, leaving them juiceless, shrivelled, and green, and not larger than peas.

*Remedies.*—In mild cases, destroy all affected leaves; this will prevent the disease spreading. In bad cases mow the bed close, rake up the leaves immediately and burn them; or the bed may be covered with dry litter and then burn off. The strawberry plant will soon throw up clean leaves if the weather is propitious. Spray with Bordeaux mixture or ammoniacal carbonate of copper, at intervals of two or three weeks, beginning as soon as the fruit is picked, or preferably, early in the season and before blossoming. Maintain a vigorous and healthy growth by means of dressings of stable manure and of chemical fertilisers.

#### GRAPE VINE.

**GRAPE ANTHRACNOSE OR BLACK SPOT** (*Sphaceloma ampelinum*, De Barry—*Glœosporium ampelinum*, Sacc.)—Two distinct forms of Black Spot occur in Australia. Anthracnose, however, is the more common as well as the more troublesome of the two. It is easily recognised, when the spots reach a certain size, by the centre becoming white, owing to the fructification of the fungus which causes the disease. On account of its appearance, the disease has been known as "bird's-eye rot." The favourable conditions necessary to its spread are warmth and moisture, either in the form of damp weather or heavy dews, accompanied by skies so cloudy as to prevent quick evaporation in the mornings particularly in the spring and early summer. Hence it is preferable, in establishing a vine-yard, to plant those varieties much affected by Anthracnose on slopes exposed to the morning sun. The winter germs of the disease are hidden in the stem and in the last year canes and develop on the new shoots and on the blossoms and grapes.



The winter treatment is by far the most efficacious in the case of Black Spot, and the varieties most subject to it should be particularly attended to, viz., Carignane, Grenache, Cèillade, Clairette (syn. Blanquette), Aramon, among wine grapes and Blue Portuguese, Black Hamburgh, Wortley Hall, Flame Tokay, Red

Malaga, Sultana, among table and drying grapes, and several other white table-grapes; the Muscats; and amongst the American grapes, V. Rupestris and V. Riparia.



Anthracnose or Black Spot.

The thread-like portions of the fungus: *hyphæ* and *mycelial* threads penetrate and feed on the tissues of the vine, during the growing period. As the vine becomes dormant, these threads thicken and give rise to the wintering form, or *sclerotia* spores which lie at the base of the buds and in the cracks of the wood, hence the winter spray and swab. When growth is resumed in the spring these spores germinate on the young shoots, their *hyphæ* or feeding portions penetrate into the tissue and "black spot" occurs.

The treatment by the acid-iron swab chars them. The application will not hurt the eyes but will delay the budding a few days. Done too early it will not kill the winter germs; if too late, it will injure the shoots. Later on in the summer the outward growth of the fungus may be attacked by means of copper sprays.

*Remedies.*—Sulphate of iron wash after pruning. Burn the trimmings after pruning. After the leaves open, use sulphur, lime, and powdered green copperas. Should the disease persist in spite of the winter treatment, it is recommended to dust the vines two or three times, at a week's interval, with cement and sulphur mixed in equal proportions, or with superphosphate of lime or with lime and sulphur. To protect trellis wires against the corroding action of the sulphuric acid, run a brush dipped in tar along the wires.

**MOULDY ROOT (POURRIDIE).**—This disease is named from the French word *pourrir*, to rot. It is caused, as in many cases of Die Back and Sour Sap, by the *Armillaria* fungus. It is difficult to eradicate. In this disease the roots are covered with a white mould which causes them to rot, the consequence being, first, a falling off in the yield per acre, and, finally, the death of the vine. The symptoms of the disease are those of general weakness and debility. The canes grow thinner and thinner, the leaves, smaller and, after a

while the trunk assumes a "cabbage-head" shape, and can be easily pulled out; the roots being rotten, brownish, and spongy. The roots of the vines affected by this parasite show, between the



Cancerous Anthracnose of the Vine.



Pourridie, or Mouldy Root of the Vine.

bark and the wood, patches of felted mouldy threads. Around the trunk, in damp soil, a growth of white cottony threads is seen, which spreads through the soil, following the roots and extending like a stain of oil.

*Remedies.*—Modify the conditions of the soil by draining and liming, to sweeten it and make it more healthy.

When the disease is just showing, pulling out the attacked plants, collecting roots and all, and burning them, to prevent the diffusion of these spores (seeds of mould) is advisable. Manuring the vines to stimulate their growth helps them to get over the weakening effect of the mould.

I have seen good results attend the application in winter-time, on the main roots and round the stock of the vine, laid bare for the purpose, a solution of sulphate of iron. Heavy dressings of lime and sulphur applied on the roots have kept down this and also similar fungus on roots of Peaches and other trees.

**DOWNY MILDEW** (*Peronospora viticola*, Le Barry, Syn., *Plasmopara viticola*).—Appears in small frost-like patches on the under surface of the leaves, finally causing yellowish discolouration on the upper surface. Berries are also affected, remaining small and hard and turning brown.

*Remedies.*—Two or three applications of Bordeaux mixture.

This disease, which causes considerable damage in American and European vineyards has, of late years, appeared in the vineyards of Victoria, and caused material damage to the grape crop in unprotected vineyards.

Oidium winters in the buds; Black Spot in the scars of the vines; Downy Mildew in the ground. For this reason winter treatment for Oidium or Downy Mildew is useless, while it is good for Black Spot. For Downy Mildew spraying should be started in October, and in the case of a severe attack, again two or three weeks later to protect the freshly grown leaves.

**OIDIUM** (Powdery Mildew) *Erysiphe vitigera* is the Australian form corresponding to the *Oidium Tuckerii* of England or the

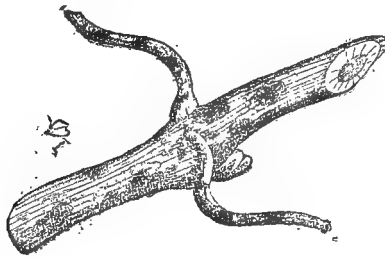

Vine Stems showing Stains of Oidium.

**Powdery Mildew**, *Uncinula spiralis* of the U.S.A.—One of the most prevalent diseases wherever the grape vine is extensively cultivated.

Before a remedy for this disease had been found, it swept out of existence the vineyards of Madeira. Some thirty to forty years

ago a number of small vineyards in Western Australia were rooted out or abandoned on account of this disease, which, at the time, was little understood.

In 1850 the presence of the oidium was first reported in France. In four years this fungus, which settles upon the grape and ruins it without materially arresting the growth of the vine, reduced the production of wine by 80 per cent. Although sulphur was proved to check the disease, vinegrowers, alarmed at their losses, sought from America new varieties of vines said to be more resistant than the European kinds. Unfortunately, from the United States they also introduced on the oidium resistant vines the phylloxera pest, which was first noticed in the South of France in 1863; the ravages of this deadly vine root aphid gradually destroying almost the whole of the vineyards of France and of Europe, until by dogged determination and patient researches the new pest was in turn conquered.

Although one of the most troublesome of the grape vine diseases, oidium is at the same time one of the easiest to subdue, provided that the treatment be carried out with care.

Like all powdery mildews, the parts attacked are covered over by the web-like threads of the mildew fungus. It only attacks those organs when green. It at first appears as a dirty white powdery film, possessing a characteristic mouldy smell. It leaves



Oidium of the Vine.

stains on the wood. Should it appear early, the flowers will fail to set; then the more tender leaves will be covered with patches of microscopic threads, which will stop their growth and cause them to shrivel up and dry. The berries are most severely attacked. The effect of the parasite on the skin is to tighten it and cause it to lose its elasticity, so that the berries either dry up or burst open.

The ripening does not progress satisfactorily, and when fermented, the juice produces a nasty wine with a mouldy taste or flavour, and one which does not keep well.

*Varieties most attacked by 'oidium, and cultivated in Australia, are:*—Albilio, Carignane, the Cabernets, Chasselas, Black Ham-burgh, Gouais, the Muscats, Œillade, Pedro Ximenes, Riesling, Roussanne (White Hermitage), Shiraz (Black Hermitage), Tokay (Green Hungary), Trebbiano (Ugni Blanc), Verdelho, and a great many table grapes.

*Varieties not much attacked.*—Aramon, Dolcetto, Grenache (Roussillon), Mataro (Mourvèdre), Marsanne (White Shiraz), Doradille, the Pinots (Burgundy), Sauvignon, Morrastel, Aspiran.

*Varieties.*—Malbec, Beclan, Catawba, and Isabella, two varieties of an American vine (*V. Labrusca*), and, in fact, most American vines.

Sulphur is the readiest cure for oidium. The finer the sulphur the better, and for that reason "precipitated" sulphur is supposed to have greater virtues than either "ground" or "sublimed" sulphur.

Washing soda (carbonate of soda) is also said to give fair results in 2 per cent. solution, *i.e.*, 2lbs. in 10 gallons on Powdery Mildew of the vine and also that of the rose bushes, peach tree, gooseberry, apple, cucumber, pears and strawberries.

Moist, warm, and damp weather favours the growth of the fungus, and at the same time checks the formation of sulphur fumes. Great heat, such as occurs in the summer, kills the blight. It is best to sulphur in the morning, when the leaves are still damp with dew, and before the high winds begin to blow. The presence of dew, however, is not essential to a good dusting. Sun heat is essential; if the weather is cooler than 70 degs. sulphur has not much effect, but it is not advisable to sulphur in too hot weather when the temperature is above 95 deg., as burning and scald stains are likely to result. The months of November and December are, with us, the most suitable for sulphuring, and in later districts it is even practised in January.

Sulphuring, to be efficacious, must be used as a preventive remedy. If it is delayed until the formation of the fruits of the fungus (*perithicia*) it does not act so readily, as the seeds of the blight plant (*ascospores*) are then more resistant than are the growing mycelial threads of the fungus.

The sulphuring is best done with the aid of specially made sulphur bellows. Some simply put the crushed sulphur into a sugar bag and shake it over each vine, but this method is wasteful of the sulphur, and does not distribute it so effectively as do the bellows.

In persistent cases, and in districts favourable for the growth of the fungus, as many as four sulphurings are given, but generally

two or three will be found sufficient. A notable saving of sulphur and in the cost of dusting is effected by mixing it in one of the summer sprays used for Black Spot or for Downy Mildew.

The quantity of sulphur per acre varies according to the state of fineness of the powder ; the sulphur distributor used ; the season, and the prevalence of the disease, from 15lbs. to 60lbs. of sulphur per acre.

When oïdium is severe, and in case of emergency, the following formula will be found to answer well :—

<i>Water</i>	...	...	...	...	...	22 gall.
<i>Soft Soap</i>	...	...	...	...	...	1lb.
<i>Liver of Sulphur</i>	...	...	...	...	...	1lb.

Reference is invited to the note regarding the mixing of sulphur and hydrated lime under the heading "The Red Mite."

This treatment is not meant to replace sulphur, but to check oïdium on grapes. The liver of sulphur acts promptly by contact,



Crown Gall or *Broussin*.

whereas sulphur acts by emitting sulphur fumes, which may be checked by unfavourable weather. There are times when sulphur

does not act as it should, because it is washed away by showers of rain, or because the temperature is too low for a sufficient emission of sulphurous acid gas. In such cases try liver of sulphur. Do not increase the dose, as liver of sulphur is corrosive, and soft soap may impart a nasty taste to the grapes.

**CROWN GALL** of the grape (called "*Broussin*" in France) shows like large cancerous growths at the crown of the vine. A knock with the hoe or the plough, the bite of insects, sunscald, or a variety of causes will produce these unsightly growths. The treatment should be somewhat similar to that of cancer of the apple.

Vines planted on land highly manured with stock manure are more liable to show these growths which are caused by a bacterial organism that attack a wide range of hosts.

Remove the growth, trim the wound, and wash the wound with an antiseptic wash, or paint it with some acid solution such as recommended for Black Spot on grapes. Knives or secateurs must be washed in an antiseptic after using.

**SQUIRT BERRY** (*Phoma tuberculata*, McAlp.).—This disease is at times troublesome, especially amongst the Muscats. The fruit is the part attacked; it is at first ashy grey or slaty blue in colour, dotted and speckled with numerous small pustules, for a long time covered by the outer skin or epidermis. When gently pressed between the finger and thumb the berry squirts out its contents. Towards the end of the season the berries dry partially, but are always pliable.

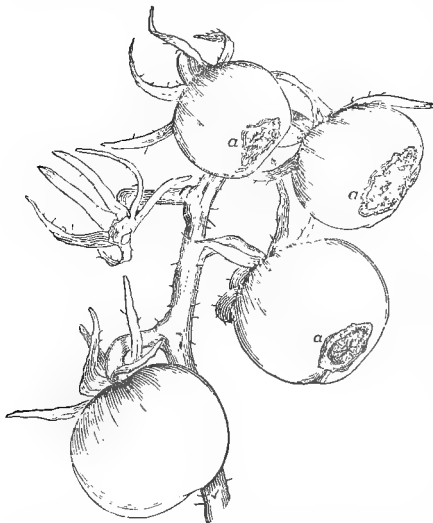

**Black Rot of the Tomato** (*Macrosporium tomato*.) The rot seen at *a* the blossom end. The lowest tomato not yet attacked.—(*Agricultural Gazette*, New South Wales).

No experiments relating to preventive means have been tried. I have noticed, however, that vines trained alongside a fowl yard were much more severely attacked than others growing a short distance away. Manuring with potassic and phosphatic fertilisers as well as liming seems to lend to the vines greater power of resistance.

## TOMATOES AND POTATOES.

**BLOSSOM END ROT** (*Macrosporium Tomato*, Cooke).—The rotting of the nearly grown or ripe tomato. Dull dark green spots of a velvety appearance show at first. These slowly enlarge, and the tomato rots entirely. The fungus is a wound parasite, gaining entrance into the ripening fruit through minute cracks. It feeds on the tissues under the skin, thus causing a little sinking below the surface of the healthy part of the fruit. Green stable manure is said to favour the disease, causing the fruit to crack. Bordeaux Mixture keeps the disease in check.

**RIPE ROT** (*Glæosporium fructigenum*, Berk).—Commonly known as Ripe Rot, and often destructive to ripe apples, pears, peaches, and grapes. Concentric markings with no velvety appearance, as in the case of Black Rot, distinguish this disease, the skin remaining for some time glossy, though discoloured; the attacked area is flattened. When the pustules break out the spores give to the surface a granular appearance.

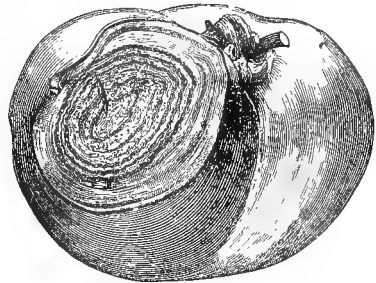

Ripe Rot (*Glæosporium fructigenum*, Berk.)  
*Agricultural Gazette*, New South Wales.

**Preventive.**—The small cherry and plum tomato are not attacked. Training the vine on stakes or trellis, so as to give the fruit plenty of light and air, is usually useful, as the Black Rot is more active in a damp atmosphere and near the ground. Burn diseased fruit and vines. Drain if necessary. Never use seeds from diseased tomatoes. Alternate crops.

**Remedy.**—Spray the young vines with Bordeaux Mixture or sulphide of potassium, and then periodically every few weeks—especially the young fruit.

**LEAF RUST** (*Cladosporium fulvum*, Cooke).—This disease spreads with great rapidity. It is caused by a fungus which forms rusty brown patches on the under-side of the leaves. These patches consist of closely packed clusters of coloured conidiophores. As these patches spread the leaf becomes yellow and wilted, the margins curl, and the leaves shrivel and die. Bad drainage and moist situations favour the growth of the fungus, which requires plenty of moisture. Trellising, by lifting up the plants into a drier atmosphere, lessens the liability of attack. Spraying with Bordeaux mixture or with sulphide of potassium (liver of sulphur) will hold the disease in check.



**TOMATO WILT.**—This trouble is caused by two different agents, viz., a fungus (*Fusarium lycopersici*, Sacc.) and a bacillus (*Bacillus Solanacearum*). The symptoms of both diseases are much alike. The first, which is known in the Channel Islands as the "sleeping disease," at times causes great damage. This disease is indicated by the drooping of the leaves, followed by that of the plant, hence the name given to it. If the plants are only attacked when the fruits are green, these ripen and there is nothing in their appearance to show that they are in any way infected. The fungus gains access to the plant through the rootlets and gradually extends to the tap root and lower portion of the stem. When it gets this far, a brown discolouration of the vascular bundles takes place, and the plant droops or "sleeps." Shortly after this stage, says Prosser, the portion of the stem just above ground is more or less covered with a very delicate white mould which consists of fruiting branches or conidiophores, which bear conidia at the tips. These conidia fall to the ground and there germinate, producing a mycelium, which attacks the rootlets of tomatoes, potatoes, egg fruit, and plants of that family, owing to the mode of attack. Spraying with fungicides is of little use. Rotation of crops minimises the trouble, liming of the soil is recommended, and above all, seeds from fruit ripening on diseased plants should not be used.

The "Bacterial" disease of the Solanaceæ is very similar to the previous one. The foliage first wilts, then the plant collapses—wilts and dies without sign of disease upon it. As the germs are in the circulation and not outside, no external treatment is of any avail. A section of a diseased branch discloses a brown discolouration of the woody cylinder, and from the vessels ooze out yellowish drops carrying the bacteria.

The disease is propagated by inoculation, generally by nibbling insects, whereas in the previous disease the fungus cannot be inoculated on the stem or the leaves, and only enters the plant through the rootlets. In the case of the bacterial disease, spray with Paris green to check leaf eating and leaf-puncturing insects. Root up and burn all infected plants; do not plant solanaceous plants in quick rotation on the same ground. Destroy all Black Nightshade weeds on the ground intended for tomatoes or for potatoes as they are carriers of this fungus and bacterial diseases.

Dr. Delacroix, Director of the Station of Vegetal Pathology, Paris, has described an organism connected with the disease in question, to which the name *B. solannicola* is given. The organism is believed to be present in the soil, from which it spreads to the plants and unfavourable meteorological conditions are said to aggravate the infection. Associated with it is a soil fungus, *Rhizoctonia solani*, which is an active parasite of the potato and the tomato plants. Wherever soil disinfection is necessary against "blue mould" which often proves disastrous to Tobacco seed-beds, the treatment suggested by Dr. Delacroix may reasonably prove satis-

factory. The treatment generally followed is the heaping up and burning of brush over the seed-bed which scorches the mould, but also burns the vegetable matter in the soil.

Dr. Delacroix recommended for the Wilt-Disease which had broken out in cotton plantations in Egypt *soil disinfection* by injections of *Formol* of commerce (formalin) which is a solution of Formic aldehyde of 40 per cent. with an addition of a small quantity of methylated spirit which insures its keeping in that solution.

Formic aldehyde has a higher antiseptic property than sublime corrosive (bichloride of mercury) which, for a long time, was considered the most powerful antiseptic known. Moreover, it is superior to corrosive sublimate, cuprous mixtures, phenols and carbolic acid, the great advantage being entirely volatile. It leaves in the soil no substance deleterious to vegetation like the substances named. It is not inflammable like carbon bisulphide which many shipping companies will not carry.

Inject into the soil with the needle force pump (Pal Injector, page 536) like carbon bisulphide using at least 50 grammes (1½ ozs.) of the solution of formal per square yard, each stroke of the piston injecting 13 grammes of the liquid.

## INSECT PESTS.

### INJURIOUS AND BENEFICIAL.

Of the insects attacking fruit trees and crops in Western Australia, the following are described in this chapter.

For easier reference, they are given in the alphabetical order of their popular names.

### ANTS.

Of these there are two main groups; the Red and the White Ants. The first belong to the *formica* family; the second are not ants but are popularly "termites."

The first category of ants burrow in the ground forming "ant-nests" on lawns and paths. Ants are troublesome when the trees are in blossom when they climb up and bite off the stamens and also encourage scale insects and aphides, being very fond of the honey-dew they elaborate. A tablespoonful of bisulphide of carbon injected into the ground, or mixed with kerosene and poured into holes six inches deep and a foot apart, and immediately filled up. Operate in the evening when all the ants are in. When the ants cannot be found, place a sponge soaked with sweetened water in their track and dip it every now and then into hot water. Another successful ant destroyer is a mixture of flour, sugar, and arsenic, made up to the consistency of putty with water. Pieces

of the mixture are placed about the nests of the ants. A great number of dead ants will be found in the vicinity of the poison. After a few days what is left of the ants generally move away to fresh quarters.

Cooper's sheep dip powder placed over the nests in the evening kills and drives them away.

It is also recommended to dissolve Hyposulphite of soda 2lb. to 2 to 3 gallons and sprinkle hot or cold in any corners indoors frequented by ants; they will disappear at once; even a plateful of the solution placed on the shelves of infested cupboards will banish them. Out of doors their heaps can be watered with large quantities of same, boiling if possible, at nightfall. This will destroy most of them.

Chalk rubbed on the bark of infested trees prevents them from climbing. If they are above it, they fall the instant they set foot on the chalk when descending as they appear to lose their foothold.

#### WHITE ANTS.

Are not "ants" and are not necessarily "white"; they are "termites." Superficially they are like ants, but they are waistless, whereas in ants a thin stalk attaches the abdomen to the trunk. Mr. Cl. Fuller, once Entomologist of the Department of Agriculture in Western Australia, and now Government Entomologist, Natal, in an interesting monograph explains that:—Like ants, they live in colonies in subterranean nests provided with communication galleries; further, at certain times swarms of winged creatures emerge which, as in the case of ants are males and females, after mating, their aerial life ceases. The bulk of the adult population of a nest consist of the "worker," and to a minor extent of the "soldier" castes. These are sexually imperfect, and may be either males or females. Except in the case of "marching termites," all soldiers and workers are blind; they may travel over exposed surfaces under cover of earthen runways where they are protected from their arch enemies, the true ants.

The viscid fluid emitted from the mouths of termites is corrosive. Wood and principally grass is the staple food. Inside the nests are sponge-like combs which are fungus gardens on which the eggs are transferred from the castle of the king and queen to hatch. The workers see to this and also collect and prepare food for the other members of the community which cannot forage for themselves; they glue and bind together the earth particles round the galleries, remove all refuse matter, dead insects and sick fellows which are devoured.

Like earthworms, they ventilate the soil, bring up the subsoil and improve it for plant growth; crushed white-ant nests is re-

garded as good growing soil. The interior galleries and chambers of the white ants nests may go far through the soil and sometimes they are driven to a great depth.

Most white ants do not attack growing vegetation although they do eat the hardwood of living trees if they can get access to it without eating through the living wood. In the North, white ants are amongst the worst pests the cultivator has to contend with. There appear to be several kinds of these termites, some feeding on dead wood only, and others on dead and live wood alike. Moist land, rich in vegetable matter, is invaded in preference to undulating and hilly localities. They are not found on springy country and on saltish marly land. The mounds vary in shape and in size, from one to twelve feet high.

In South Australia it is noticed that the white ants are troublesome in sandy and limestone soils, occasionally destroying vines and showing particular liking for the Sultana vine. Mr. F. A. Marlatt also records them as doing damage to potatoes growing in rich soil or where there is a considerable quantity of decaying vegetable matter.

Peach trees are not destroyed, and oranges, mangoes, avocados, tamarinds and date palms are amongst fruit trees seldom attacked. At Port Darwin I was told that the *Meso termis* Darwini, attacks growing citrus trees but not the Lime, which resists best and bears well. The fact suggests the possibility of this tree being utilised as a "stock" if grafted some way above ground. In the South-West of Western Australia white ants are smaller and not so destructive as they are in the North-West and in the Kimberleys.

*Treatment.*—Consists mostly in circumventing and preventing this attack. In tropical countries they do a lot of harm and in the Malay States and in Java I have found them very destructive on new plantations. As white ants become better known, more efficacious means of combating them will be employed. Well-directed attack and systematic and thorough cultivation will do a lot to check the pest.

When driven to it by starvation, as on infested land that has been cleared of vegetation they more eagerly attack trees and plants which, under circumstances, they would not touch.

After clearing the land for tree planting or for cropping, all stumps and roots which may harbour or attract the termites should of course be removed and a search made for their nests; the same precautions is advisable when building a house. The practice of breaking down the mounds on new land and obliterating the seat of the nests makes it more difficult to locate them for subsequent treatment.

For that purpose, an apparatus used in South Africa and which I also found employed with marked success in the Malay States effects efficient clearing work. It is called "The Universal White Ant Exterminator."

The apparatus consists of a hand-pump connected with a fire-box in which a charcoal or dry cow dung fire burns. Over this a spoonful or two of a mixture consisting of three parts of arsenic and one part of flour-of-sulphur is spread; the lid is closed and the pump worked. The fumes are conducted through a flexible iron hose with a nozzle that is placed in one of the galleries. After a

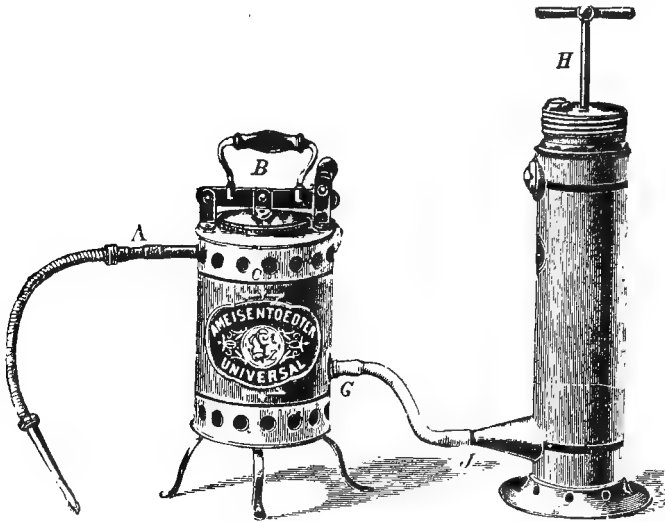

few minutes, white fumes are seen to escape from unnoticed openings in the ground; these openings are blocked with damp clay. The hot poisonous fumes kill the insects both by contact or by leaving along the galleries a film of poison which subsequently kills the pest and renders the nest unfit for a fresh invasion for some time after. The poisoned insects are also devoured by stragglers and thus the arsenic is transmitted right through the nest.

Other fumigators, viz., the "Bosker" and the "Snuff-out" carbon fumigators, are now advertised for sale in Perth. They are primarily designed for rabbit-destruction in the warrens by carbon fumes, and are fitted with patent fire-grate for burning the fumigating mixture and with flexible steel tubing for conveying the gas from the fumigator to the underground gallery. The fumes are not dangerous in the open air.

A number of other methods, more or less successful, have been found useful, and in view of the fact that the white ants are so bad in the North provinces, I will enumerate them as they appear in my notes.

1. Watering, irrigation, and cultivation reduce the attacks. The majority of the species abhor disturbance.

2. Poisoned Baits—locust and cut-worm baits—Sawdust may be substituted for the pollard. In localities where they abound, it is advisable to kill them before planting trees, using arsenic in an insoluble form lest roots be poisoned, *i.e.*, Paris Green—arsenite of lead or arsenite of lime. The bait is placed in holes near the stems of attacked plants covered to exclude light. Damp bags sprinkled with poison bait and buried under new houses attract foraging parties.
3. Cinders with ashes with a surface dressing of tar under houses is said in some cases to act as a repellent.
5. In Jamaica the following paint is recommended :—
 

<i>White Lime (slaked)</i>	...	...	...	6 qts.
<i>Kerosene</i>	...	...	...	$\frac{1}{2}$ pt.
<i>Turpentine</i>	...	...	...	1 wine glass.
<i>Soft Soap</i>	...	...	...	5 lbs.
<i>Cow-dung</i>	...	...	...	3 qts.
<i>Water</i>	...	...	...	16 qts.

Mix thoroughly and apply freely with a paint or white-wash brush to trunks of trees or stems of plants requiring protection. The mixture adheres to the trunks and branches of the trees for a long time, but when it peels off the bark beneath is clean and free from pests.

6. Carbon bisulphide poured in with a funnel into an augur hole towards the top of the nest or mound ; the heavy fumes sink into the ground. If smoking, beware of explosions.
7. A plug of dynamite with a length of fuse attached—but no detonator—inserted into a gallery and then lighted. No explosion takes place but the dynamite burns away giving off a poisonous gas.
8. Also kainit well dug into the soil, For garden plants watering frequently with a solution of bluestone *i.e.*, 1lb. in 50 gallons water, does not appear to do the plant any harm.

#### PLANT APHIS AND BARK LICE.

are among the most numerous, both as regards species and individuals, of all known insects, and the destruction caused by them is commensurate with their numbers. There is scarcely a plant that is not attacked by them, and some like the grape, peach, apple, cherry, orange, and cabbage, etc., have aphis peculiar to them.

They are all small, soft-bodied insects, with a body more or less pear-shaped, the winged forms having two pairs of delicate trans-

parent wings. The majority of plant lice are aerial in their habits, but some varieties also assume a subterranean form, and these are among the most destructive and widespread, the phylloxera and woolly aphis being the best known.

Their methods of reproduction are most unique and peculiar to themselves, and the different forms they assume—some winged and others wingless, some laying eggs, others bringing forth young alive and often without the intervention of the male, which in some forms has never been recognised, and make them at once interesting and puzzling to the naturalist and entomologist.

In many varieties a sweet substance is produced, called "honeydew," which is exuded through two tubes situated on the back near the posterior part of the insect (*see* page 583), which can readily be seen with the naked eye. This is the substance, when produced in large quantities, that drips upon the leaves and branches of infected plants. This honeydew is devoured by bees, wasps, and ants, and supplies food to the black soot fungus or fumagine. It is commonly believed that ants destroy plant lice, but the contrary is the fact. Ants treat and regard plant lice as milch cows. Ants have been observed to approach a plant louse, place its antennæ on its back, stroking it gently, when the louse will give forth its honeydew, which the ant will immediately drink up. The ants take good care of the lice, and will transport them to new pastures when old ones fail, thus aiding greatly in their distribution.

Plant lice obtain their sustenance by sucking the juices of plants, by inserting their proboscis in woody plants, in the tender terminal growths, peduncles of roses, etc., and in the succulent parts of plants and roots. While the amount taken by an individual is almost infinitesimal, their immense numbers often cause most serious injury to the plant they infest, and sometimes its destruction.

#### CABBAGE APHIS (*Aphis brassicæ*, Linn.).

There are several modes of dealing with this pest, and among them the best is to spray with Nos. 7, 8, 10, 14, 15, 19, or 20. (*See* pp. 527-531).

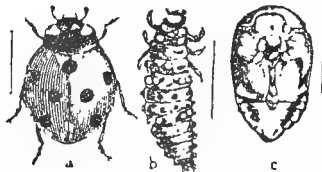

Aphis-feeding Ladybird (*Coccinella septempunctata*), a adult beetle; b, larva; c, pupa. All enlarged (after Berlese).

Two species of ladybirds—*Leis conformis* and *Coccinella septempunctata*—which prey upon this aphid have been introduced into the State, as well as two species of Ichneumon flies.

WOOLLY APHIS (*Schizoneura lanigera*).

This species, in addition so secreting a honeydew, secretes a bluish white flocculent, cottony substance, which oftentimes almost completely conceals them, appearing to be tufts of cotton attached to leaves and twigs. This pest has been distributed to every apple-growing country, but its place of origin is not yet known. It is, however, one of the most annoying pests with which the apple-growers have to contend against. They have been seen infesting the branches and trunk of a tree, in which they form pits, the bark apparently ceasing to grow at the point attacked, swelling into a ridge about the cluster of aphides. Those that appear above ground can be controlled

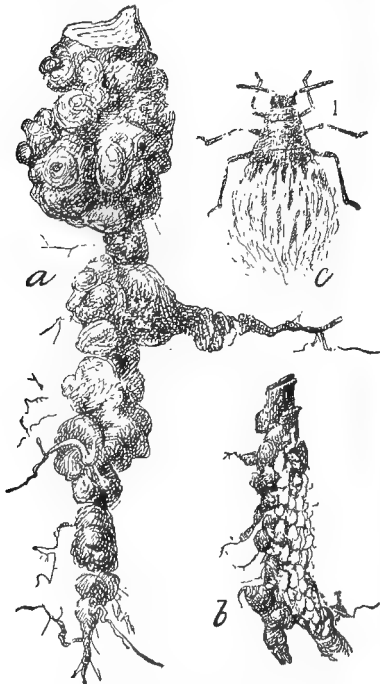

Woolly Aphis, (*Schizoneura lanigera*),  
a, b, roots; c, louse (Marlatt).

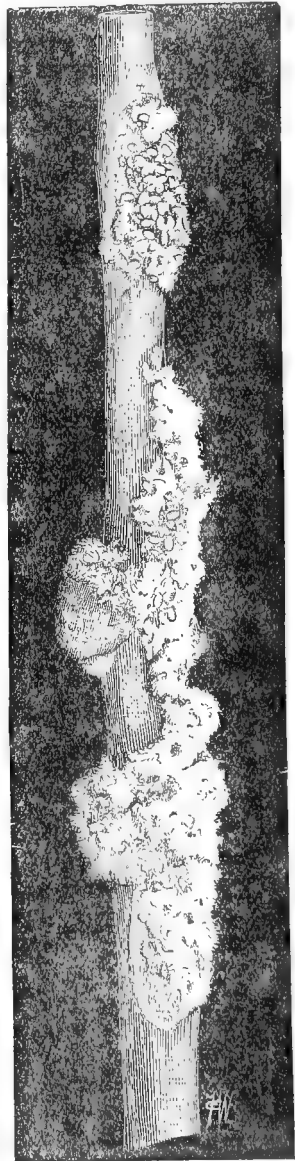

Woolly Aphis on Apple Tree branch.



more or less, but the form which assemble on the roots and there produces gall-like swellings is much more difficult to extirpate. Every part of the tree which is not blight-proof is liable to be attacked, but the roots are now protected by grafting or a resistant stock of which the best is the Northern Spy. The injury to the tree is caused by the sucking of the sap, which deprives it of nourishment, and by poisoning of the plants, shown by the galls on the roots. The damage is particularly serious in the case of young trees and nursery stock. The mature bark unless bruised or cut is less penetrable, but the bark on the tender growth is easily attacked, hence the blight being more particularly severe in young apple orchards. Some varieties are more liable to be attacked than others, viz., the Jonathan, Reinette du Canada, Cleopatra.

Among the many remedies used for the destruction of the woolly aphid are Nos. 6, 7, 8, 12, 14, or 20, also kerosene (*see* p. 526). A fortnight after Nos. 10 or 14. The use of blight-proof stock, and No. 9 have been proved satisfactory. A jet of water ejected under pressure from a force pump or in suburban gardens from the water service pipe, when the pressure is good, is an efficacious way of dealing with the pest, provided the treatment be frequently applied, *i.e.*, every two or three weeks in the summer time. These jets of water under high pressure dislodge the woolly aphid, as well as other aphides, mites, red spiders, clean the tree without destroying the friendly natural enemies of our orchard pests, and give the tree a refreshing spray, without having any of the injurious results of poisonous and caustic sprays.

*Natural Enemies.*—The woolly aphid has very few known natural enemies. The larvæ of some species of lace-winged flies (*Chrysopidæ*) have often been noticed feeding upon this pest, and the ladybird (*Leis conformis*) and (*Coccinella repanda*) have been known to almost rid whole orchards of it.



New growth of peach infested with black peach aphid.

#### BLACK APHIS OF THE PEACH (*Aphis persica niger*).

This aphid has proven very destructive to the peach trees of this State, and as it exists in two forms, aerial and subterranean, similar to the woolly aphid, its control is subject to all the perplexities of the latter aphid. It attacks the leaves when they are pushing in the spring, and it

multiplies so rapidly that it frequently kills young trees and seriously damages larger branches on older trees.

When trees are badly attacked by this aphid the leaves are yellowish, more or less curled, and spotted with fungus.

*Remedies.*—In winter, dress the soil around the stems of trees with gas lime, kainit, fresh manure, a bucketful of No. 7 or No. 15. In spring, spray with Nos. 7, 8, 14, 18, or 20 (see pp. 527–531).

*Natural Enemies.*—The larvæ of several species of ladybirds feed upon the peach aphid, as do also the larvæ of various species of Syrphus flies. True parasites of this aphid have as yet not been discovered, for the reason that the country to which the aphid is indigenous has never been found.

#### PLUM AND CHERRY APHID (*Myzus cerasi*).

This aphid closely resembles the peach aphid in general colouring and shape. It appears as soon as the leaves of the trees on which it feeds expand and multiplies very rapidly, being hatched from eggs deposited on the branches during the previous fall. They are not so abundant in midsummer, but become numerous again in the autumn, when the sexes appear and deposit their eggs at the base of the buds and cracks of the bark where they remain during the winter, and hatch the following spring. They secrete a large amount of honeydew, which attracts numerous flies and ants.

*Remedies.*—Use Nos. 7, 8, 9, 14, 15, 19, or 20 (see pp. 527–531).

#### ORANGE APHID (*Siphonophora citrifolii*, Ashm).

This insect attacks the young wood of the orange in the spring, covering the trees so thickly that they appear quite black. Colour of insect, brownish to shiny black.

*Remedies.*—Use Nos. 7, 8, 14, or 20.

*Natural Enemies.*—This species, as well as the plum and cherry aphid, have many natural enemies, which aid greatly in keeping

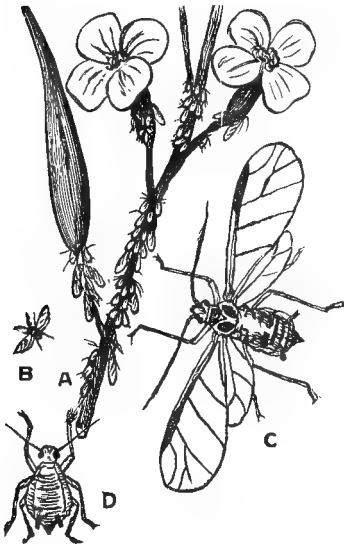

a Showing aphid on flower stem of cabbage. b The winged louse (natural size). c The same enlarged; colours, greenish yellow. d Wingless female.

them in check. In fact, were it not for these natural checks to aid man in preventing the destruction of his plants, all his efforts would prove unavailing. Among the most active in this warfare are the parasitic flies, which are mostly very small and with four transparent wings. They lay a single egg on a louse, which hatches and produces a maggot in the interior of the host, and which feeds on the juice of the louse until it changes to a pupa, from which it emerges through a small hole cut in the body of the louse. A close inspection of a family of plant lice will disclose many with this hole in them. A parasitised louse may be told, even before its death, by the swollen abdomen, which will distinguish it from its non-parasitised mates.

One of the most numerous of the predaceous insects is the *Syrphus* or flower flies, which may be seen hovering around flowers remaining for a short time stationary in the air. They bear a

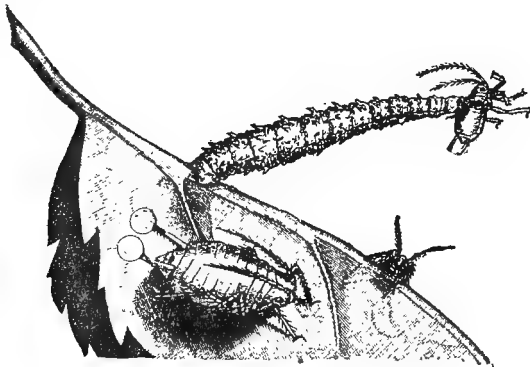

*Syrphus* fly larvæ in the act of sucking out an aphid.

resemblance to some species of wasps, with broad yellow band across the abdomen. The fly in its matured state is of no economic importance. The larvæ, however, are very destructive to plant lice. The parent fly lays a single egg among a cluster of lice, this hatches in a few days, and immediately commences its work of destruction. It seizes a louse, and holding it aloft while it kicks and struggles, sucks the juice



*Syrphus* fly.



*Syrphus* fly larvæ sucking out the vital fluids of an aphid.

from its body, and then casts the empty skin away. These maggots are blind and have no distinct feet, but they have no trouble in

finding a louse by extending the segments of their body, which enables them to nearly double their length, and to strike here and there until they find their prey.

Some species of ladybirds are also important factors in the destruction of plant lice, both as adults and larvæ; but as they consume the entire louse, they

cannot compare with the larvæ of the *Syrphus* flies in the speedy disposal of aphids. A *Syrphus* fly larvæ will dispose of five to seven lice while the ladybird larvæ is consuming one.



Lace-winged fly.

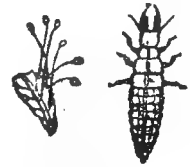

Laced-winged fly, eggs, and larvæ.

### CABBAGE MOTHS.

The larvæ of two kinds of moths are, says Mr. Lea, late Entomologist to the Department of Agriculture, very destructive to the cabbage and turnip. These are the cabbage or diamond-back moth (*Plutella cruciferarum*) and the stinking-head moth (*Evergestis rimosalis*).

*Plutella Cruciferum* (Zell). — The larvæ of this little moth (which is common all over the world) are very destructive to the cabbage, cauliflower, and turnip. The leaves have small holes eaten in them, and these holes are frequently so numerous that more than half the leaf is devoured; with cabbages the inner leaves are seldom attacked, though larva may occasionally be seen in the heart itself, the damage is usually to the outer leaves; with cauliflowers every leaf is attacked and the crown is frequently covered with excrement and web, becomes of a brown colour, and is totally unfit for market;



Cabbage Moth, showing larvæ, pupa, moth and parasitic wasp.

hundreds of larvæ and pupæ may be seen on one plant. The larvæ is pale green in colour, and, on being touched, jerks itself

about and drops down, usually by a fine silken thread ; when about to pupate it spins a loose silken cocoon generally close to the mid-rib, the cocoon is so slight that the pupa can always be seen through it. The moth is a small slaty-grey insect with diamond-shaped white marks along the middle of the folded wings ; it is readily attracted to light. All over Australia the larvæ are very severely parasitised by a small Ichneumon wasp, and so numerous are specimens of this insect that it is doubtful if 20 per cent. of *Plutella* larvæ ever becomes moths. The larva of the parasite is a small legless maggot which, when full-fed, constructs a small cocoon within that of the larva it has destroyed. The larvæ of *Plutella* have numerous other enemies, amongst which may be mentioned two species of Syrphus flies, two Chalcids, and several predaceous bugs.

Some years ago two additional species of useful parasites have been introduced into this State.

*Remedy.*—Spray with Nos. 11, 13, or 19, or sprinkle with Paris green, 1oz., in flour or lime, 5lbs.

Another species of moth (*Evergestis rimosalis*), the larvæ of which does much damage to cabbage and cauliflower and also turnips, is also found in this State. The moth is a pretty yellow, with the front wings irregularly spotted and striped with chocolate and paler yellow markings. No parasites have been bred from the larvæ.

*Remedy.*—Spray with Paris green, 1oz. in flour or lime 5lbs., or spray with Nos. 11, 13, or 19.

#### CASE-MOTHS OR BAG-WORMS.

Fruitgrowers are familiar with the little inverted cone-shaped cases which are to be found hanging to the branches and twigs of their trees. There are two kinds which attack apple and pear trees, and the cases should be pulled off and destroyed, as the caterpillars contained in them are responsible for many of the disfiguring marks to be found both on fruit and leaves. They are night workers, and remain suspended by a silken thread during the day. The cases are beautifully constructed out of the little bits of wood and leaves fastened together by a strongly woven silken material secreted by the insect. In some places they are most abundant.

*Remedy.*—Hand pick and burn.

A large number of larvæ of butterflies and of moths are destroyed by soldier bugs, which are beneficial *Hemiptera* insects. They pierce the bodies of the grubs with their beak and suck them dry.

A DESTRUCTIVE COCKCHAFER (*Anoplothesus Opalinus*, Brulle).

Cockchafers are large beetles, belonging to a family known as *Scarabaeidae* or *Lamellicornes*. Mr. Lea, in writing on this insect, says:—"Nearly all the members are destructive in their larval stages, when they feed upon roots, decaying wood, or actually bore through

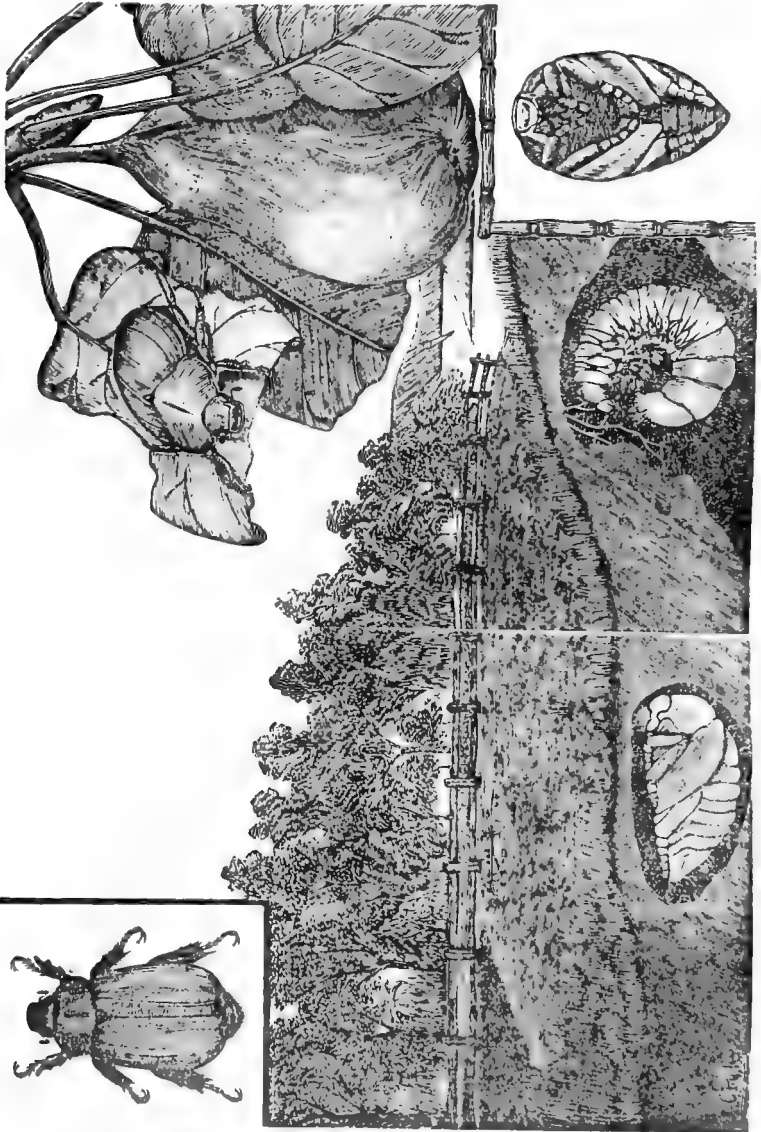

solid timber; a number (to which belong the sacred beetles of Egypt) are useful from their habits of burying the excreta of animals, and so directly fertilising the soil. In England, I believe, it is only beetles belonging to the sub-families *Melolonthides* and *Cetonüdes* that are known as cockchafers, but in Australia any large lamellicorn is spoken of as such: members of the sub-family *Rutelides* (to which *Anoplostethus* belongs) being commonly spoken of as cockchafers. In Europe and America a number of species have been recorded as extremely destructive during certain years. In France and elsewhere, large areas of grass and cereals have been entirely destroyed by having the roots eaten, the grass withering up and blowing away, so that fields were left entirely bare. When full grown, the cockchafers feed upon leaves and petals of flowers, and occasionally do serious harm from the great numbers in which they occur, and their occasionally migratory habits. The species now treated on is one which is found only in this State, and is extremely common during late spring and summer, nevertheless, unless specially looked for, it is seldom seen as it only flies at night, remaining concealed during the day underground or on the shady side of a leaf; on a sultry night a specimen may be sometimes taken at a lamp or other light. During November and December, at dusk, I have seen swarms of these insects flying around lemons, pear, peach, and other fruit trees; on examining these trees afterwards, large numbers of leaves were noticed to have been partly eaten.

The larvæ feed upon the tender roots and the larger roots of fruit-trees, vines, buffalo, couch, Cape lilac, etc., and their presence is often unsuspected, the damage, if noticed, being put down to pooriness of soil, want of water, or other cause. They probably pass a couple of years underground before changing to pupæ, which state must last for but a short period, but probably for several months.

The beetle is about an inch in length and rather bulky, and it is of a beautiful opalescent green, rendered still more beautiful by placing the insect in water or spirits; its shape, as also that of the larva and pupa, has been well shown by Mr. Fuller in the accompanying wood block. The larvæ has the usual shape of a lamellicorn, and, with other species, may often be noticed whilst ploughing or digging is being carried on: numbers may often be noticed under logs in damp situations. The pupa is enclosed in a brittle, sandy cocoon, differing in this respect from that of the wood-eating species, which are usually hard and formed of triturated wood and excrement.

The larvæ (at least so far as my observations extend) appear to be free from internal parasites; they are, however, attacked by a small semi-transparent mite, sometimes in considerable numbers. The winged beetles frequently contain the maggot of a fly belonging to the *Tachinidae*, which, when fully developed, is about the size of

the common blow-fly. At an early date it is intended to give an illustration of this species, as internal parasites of fully grown beetles are excessively rare, only two instances of such have ever come under my observation. On the under surface of the beetles small ticks belonging to the *Ixodidae* may occasionally be seen, and at the bases of the wings a few small red mites have been noticed. It is to birds that we are especially indebted for keeping this and similar insects in check. Our native insectivorous birds—notably the magpie—are well worthy of protection. Poultry are especially fond of them.

#### HONEY BEETLE AND SPRING BEETLE.

These beetles appear in the spring sometimes in plague form. The first one, says Mr. L. J. Newman, Government Entomologist, is brown with black at tips of wings—*Phylloctocus ustulatus*.

The spring beetle—*Colomyforma lineata*—is smaller and greyish-green in colour.

They breed through the South-West in grass and scrub land. The larvæ are root feeders, and go through that stage outside the orchard. The adult beetle ceases to be noticeable in the early summer.

Treatment: Spray the infected trees with 1lb. arsenate of lead, ½lb. flour, 8 gallons water; or 1lb. Sunlight soap, 5 gallons water.

#### THE CODLIN MOTH.

The first report of the Codlin moth in Western Australia was recorded in 1902, and was traced to some apples smuggled into the State despite the prohibition regulations. Following this several sporadic outbreaks came under notice in Chinese gardens at Perth, Albany, and on the Swan. Prompt and effective means were taken for quarantining the infested spots, and, at the time of writing, Western Australia may again be declared free from that pest.

#### *Description.*

The Codlin moth (*Carpocapsa pomonella*, Linn). It is so called because in Europe it mostly attacks the early culinary or "codling" varieties.

The *moth* itself is about half an inch in length, when at rest, and measures about three-quarters of an inch across the expanded wings. The fore wings are grey, crossed with wavy brown lines, and are ornamented with patches of metallic bronze scales near the margin. The hind wings are light brown. The male is supplied with a dark narrow space on the lower surface of the front wings, and a narrower stripe on the upper surface of the hind wings. These dark spaces, says A. M. Lea, are due to hairs, and are absent in the females.



The *egg* is white, scale-like, and flat. Smaller than the head of a pin, it is not easily seen on the fruit until the young grub has left it, when it soon after falls or is blown off.

The *larva*, or grub, on hatching, is one-sixteenth of an inch in length, and, when full grown, ten times as large, or five-eighths of an inch. It is of a fleshy pink colour, and is covered with a few stiff hairs. The male, says A. M. Lea, can be distinguished from

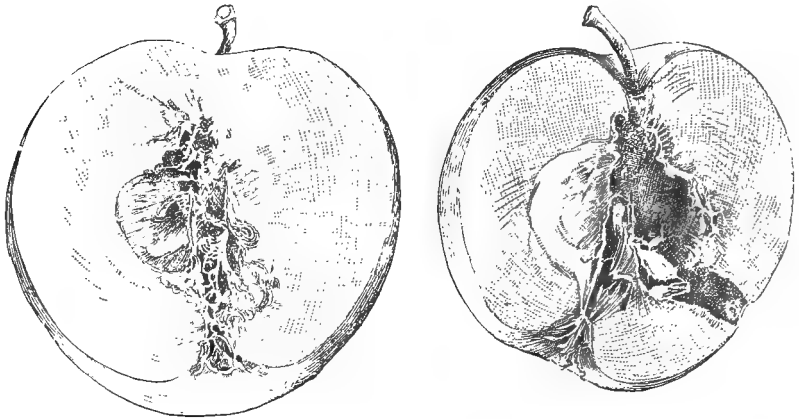

Apple attacked by the Codlin Moth.

the female by the presence of a small dark space in the centre of the body, that can be seen through the skin. The grub of the light brown, or false codlin moth (*Cacaecia*), is chiefly differentiated by its dirty green colour, besides being considerably thinner.

The *pupa*, or chrysalis, is brown, and about half an inch in length; when empty, it is a very pale brown.

The *cocoon* is made of white silk, and is joined to, and more or less concealed by, the bark or bandage, wherever it is placed; it is never loosely placed, and frequently the grub eats a small hollow space for its reception. I have often seen these cocoons between the nailed end of the battens, and the end or centre board of fruit cases, in places where one could hardly insert the blade of a knife, the grub having practically eaten for itself a hollow chamber, where it spins its cocoon.

#### *Introduction and Distribution.*

The codlin moth is as widely distributed as the apple itself. It is a native of Europe, where, owing to the fact that it is there kept in check by climatic conditions, or by natural enemies, it is not so mischievous as it has proved to be either in America or in Australia.

It was introduced into the United States, from Europe, soon after the first settlements were founded. In 1874 it appeared in California, and is supposed to have been brought in old fruit boxes. It appears to have been introduced into Australia from California, and was first recorded from Tasmania sixty years ago, in 1861. During that time it has ruined many a fruit grower, and even now levies a heavy tax on most apple growers in the Eastern States of Australia, as well as New Zealand and Tasmania.

This pest does not attack apples exclusively, but it is also found, although not so commonly, in pears and quinces. When driven to it, the moth also turns its attention to hard-flesh plums, peaches and apricots. It has been seen (but very rarely) on the cherry and walnut. Although reported in the tomato, the grubs have in every instance proved to be the well-known pests of that fruit, the *Heliothis armigera*, or *Mamestra composita*, whose grubs are much larger than that of the codlin moth.

In Bulletin 142, Cornell University Experiment Station, on the Codlin Moth, 1898, by M. V. Slingerland, the following estimation of the amount of damage done by the moth occurs:—"Conservative estimates put the annual loss from its ravages, in all countries where it is noticeably destructive and but little is done to check it, at from 25 to 75 per cent. of the crop of apples. Where modern methods of combating the insect are practised this percentage is often reduced one-half or more."

Lea, in 1900, estimated the loss annually caused in Tasmania by the codlin moth at £30,000, "this, however, is probably far below the mark."

"A loss in an orchard of 50 per cent. is by no means uncommon, and I have myself (says Lea) seen an orchard near Launceston every apple in which was struck, and many of which contained two, three, or four grubs. From an orchard near Hobart as many as 11,000 infested apples have been picked to the acre." At five apples per pound this would give 2,200lbs., and at 40lbs. of apples to the case, 55 cases of grubby apples per acre.

Western Australia, as already stated, is not yet known to be infested with the codlin moth; and this is entirely due to its comparative isolation, and to the wise legislation introduced some thirty years ago, and prior to the introduction of Responsible Government. The measure, an Order-in-Council, under date 7th March, 1889, absolutely prohibited the importation of apples, pears, and quinces on any point of the West Australian coast south of Champion Bay and the port of Geraldton. The late Bureau of Agriculture has often been given credit, or has been abused, for this wise piece of legislation, but it is seen that the Order-in-Council was enacted some five years before the Bureau was constituted,

On the 5th July, 1901, another Order-in-Council revoked this order, and since then the prohibition of apples, pears, and quinces has been removed; but the importation is restricted to two ports of entry, where an efficient method of inspection and of fumigation has hitherto proved successful.

### I *Life History in Australia.*

Apple trees blossom in Australia from the last week in September to the end of October, and a week or two after the opening of the petals the first codlin moths issue from the pupæ or chrysalis, and the males and females mate. The proportion of these is fairly balanced. From observations made, the female lays 80 odd eggs. The mother moth flies about at dusk, or even earlier in the day if the weather is cloudy, and lays one egg on each apple (if more than one grub is found in the fruit then the eggs have been laid by different moths); that egg is more frequently deposited about the eye, but it is sometimes seen on the stalk, or even on leaves.

The eggs are sometimes infertile, especially in cool, foggy localities, where the parent moths either fail to mate, or on account of the egg not having sufficient warmth to hatch. The first theory is the more likley under Australian conditions. During the egg-depositing period the moths are said to fly long distances in search of a suitable place to lay their eggs, and are often carried in the direction of the prevailing wind.

The eggs hatch in from seven to ten days, and the young grubs grope about nibbling at the fruit, generally about the eye, where they have their first few meals. Shortly after, they strike the apple and effect an entrance into the fruit, generally in the eye, but at times from the side or at the place where two apples touch, or where a leaf is resting on the fruit. Once this fruit is struck the young grub goes on tunnelling towards the core of the fruit, coming back to the entrance to void its castings, and afterwards leaving them in the tunnel. It soon reaches the pips, one or more of which it eats, and then, in about a month's time, when full fed, it carves a tunnel out for itself, generally on the side of the fruit, but sometimes, although rarely, along the same channel it cut when entering into the apple. This channel is not always visible from outside, but when the apple is cut into often becomes noticeable.

When full fed it either comes down with the fruit, which drops prematurely, or it lets itself down by means of a silky thread, and it then proceeds to seek shelter. This it finds, in most cases, under loose bark on the trunk or the main limbs of the tree itself or on adjoining trees, or on fencing posts, under heaps of rubbish, among empty cases, potato bags, or other packages, in the cracks of adjoining buildings, in piles of rubbish, or under dry clods; it has even been seen in the tails and manes of badly groomed horses

Once secreted, it spins for itself a protecting cocoon, and after a time varying from a few days to as many weeks or even months, it metamorphoses itself into a pupa or chrysalis, when it remains in that state for 10 to 20 days, after which it emerges into a perfect insect.

It is thus seen that when the circumstances lend themselves to its uninterrupted evolution during the warmer months, the codlin moth takes 40 to 50 days to pass through its metamorphosis; it often takes much longer. Lea, and with him other careful observers, state that the full-grown grub or larva is, on the other hand, often weeks operating its transformation. It often lies in a semi-comatose state, curled up within its web, all through the autumn and the winter, before it changes into a pupa or chrysalis.

The theory of multiple broods through the summer months is now fading away under the light of modern observation. A certain proportion do metamorphose into moths again during the season, but the majority of grubs pass the winter without changing to pupæ. Lea and others affirm that in most cases only one brood is hatched during the season.

Just as the grub or larvæ do not pupate all at once, so during the apple season all the moths do not come out at the same time. Those in the gullies, says Lea, will come out later than those in the open, and those on the sunny side of a tree before those on the shaded side.

This irregularity has led many people to think that the moth was double brooded in Tasmania and other Australian States. The test to complete absence of empty chrysalis cases (not cocoons) in the bandages during January and February is, in Lea's opinion, conclusive evidence that in Tasmania there is but one brood to deal with.

#### *Outward signs of Wormy Fruit.*

1. A careful examination of a wormy apple often shows, in the locality of the calyx, or the eye, a minute puncture surrounded with the castings of the young grub, more or less entangled in silky web. In some apples this is more apparent than in others.

2. Frequently, when the apples are growing, a brownish, gummy substance may be seen oozing from the eye; and this substance invariably denotes the presence of a grub.

3. When the hole is made in the side, this gummy substance is very seldom seen, and the hole is generally covered with web, to which small particles of excrement adhere. After the grub has left, the hole is generally left partly uncovered, and the excrement (which is frequently matted together with web) rapidly turns mouldy, but it appears never to turn mouldy when the grub itself is present.

4. Wormy fruits often colour and show signs of ripening a fortnight or more before healthy ones, and they will frequently drop. Soon after they strike ground, and often within a day or so, the concussion will urge the grub to come out.

5. When the grub has made its exit a noticeable hole is seen on the fruit.

#### *How to Fight the Codlin Moth.*

1. The first essential of a successful attack against the codlin moth—and, for the matter of that, against all manner of plagues, blights, and pests—is concerted action.

2. Where an outbreak first takes place in a clean country or district, the readiest and most reliable way of stamping it out is the *starving out* method. This, when carried out in an energetic manner, is unquestionably the best means of coping with an outbreak.

3. An ounce of prevention is worth a pound of cure. Never use second-hand fruit cases.

4. The life-history sketch of the moth indicates that each female moth is good for 80 eggs or more, half of which are females. It thus becomes apparent that every worm, or every moth, destroyed at the beginning of the season is worth a great number later. Every effort should, then, be directed towards their destruction in the early spring. With this end in view, all apple sheds or storerooms should be thoroughly disinfected by means of hydrocyanic acid gas, sulphur fumes, or hot steam. Every apple storeroom should be made secure against escape of the moth; for this purpose wire screenings should be placed over the inner doors and windows, which should fit well.

5. The apple orchard should be free from rubbish heaps. Wire fences are less subject to harbouring the grubs than wooden ones. The ground should be kept well cultivated and clean, and the older trees should have the loose bark scraped.

6. In badly infested districts in Tasmania, which, by the by, has grappled with the codlin moth question with more thoroughness than have yet the other Australian States, "it has been found necessary to so prune the trees as to allow the pickers to see into any part of them; also, to keep the trees low, as it is, of course, much more difficult to go over high than low trees."

7. All windfalls in infested localities should be gathered as fast as they come down, as unless this is done the wormy apples will, after the concussion they have received, be soon deserted by the grub. This should be more particularly attended to in January, February, and March.

8. Night light traps, with a lantern hung over a tin tray containing some sticky substance have been recommended, but the

great majority of observers now admit that the codlin moth is not attracted by light, and that when a few odd ones are thus caught the event is more of the nature of an accident.

9. Traps with fresh apple juice sweetened with sugar or honey have been tried in South Australia, New Zealand, and Tasmania with more or less success. Lea used such traps in February and March, and, "so far as the codlin moth was concerned, they were total failures." Possibly, says he, if used in December and January they would have been more successful.

10. Arsenical sprayings is, of all the weapons used against this pest, one of the most deadly. It aims at depositing on the surface of the young apple, pear, or quince—and in such a position where it is likely to be picked up by the young grub soon after it hatches—a bait that will prove fatal. A better understanding of the habit of the codlin larvæ enables us to better encompass its destruction.

The cost per acre of each spraying, according to the size of the trees, may be put down at six to twelve shillings. To ensure a clean crop three to five sprayings are necessary.

Observation has taught that the mother moth lays one egg on each apple. Should the egg be a fertile one, and should it escape detection by natural enemies, it soon hatches; the young grub then instinctively crawls towards the calyx or eye of the fruit, and there has its first feed or two. It also nibbles here and there at the outer surface of the fruit, and after having had a few feeds proceeds to bore into it. It is whilst thus feeding that it picks up the poison. That poison, it is seen, must therefore lie where it is most accessible, and this is done in this way: After the petals drop, and as the fruit develops, the sepals which are disposed around the eye, and which, when accompanied by the corolla, are uniformly expanded and spreading, soon assume various shapes, covering more or less the tube which constitutes the calyx cavity. It is before these sepals close that cavity that the spraying should be done, and the most propitious time for this operation is about a week after the setting of the fruit. When this is done a certain amount of the poison is imprisoned within the calyx, where we know that most codlin grubs generally have their first meal. Should, however, the spraying be delayed, the poison will not be deposited within the calyx cavity with the same certainty, and fewer codlin grubs will have a chance of picking it up. Should rain supervene after the spraying, it is advisable to spray again in order to get at the later hatched grubs, as all moths do not emerge from their chrysalis stage all at once, but come out from October right on till the middle of summer.

Slingerland, commenting on the results of spraying with arsenites, reports that at least 70 per cent. of the loss commonly suffered by the fruit-grower from the ravages of the codlin moth could be

prevented by thoroughly applying the arsenical spray once or twice in the spring, indeed, "thousands of practical fruit-growers, who have thoroughly tried it, are unanimous in their testimony that from 50 to 90 per cent., in some cases, of the fruit that would otherwise be ruined by the insect, can be saved at a comparatively slight expense." Any of the several arsenical poisons may be used, viz., Paris green, London purple, white arsenic, arsenite of lead, etc. Of these arsenate of lead and Paris green are the best, when unadulterated, and in the hands of the average fruit-grower, that which are the safest to use.

11. Bandages, when well applied and carefully attended to, are better than any of the patent traps yet tried. Next to spraying, the greatest number of grubs can be destroyed by its use, and from 40 per cent. to 50 per cent. of codlin larvæ are said to have thus been entrapped. The bandages are made of wide bands of hessian, about 12 inches wide, and long enough to encircle the stem of the tree. The piece of stuff is folded in the middle and fastened tightly round the tree by means of twine.

"According to the regulations at present in force in Tasmania, the bandages should be placed on the trees in November, and finally taken off not later than the following July." They should be removed every eight or ten days and boiled—this boiling also destroys a great many eggs of red spiders—and then replaced. This is preferable and more reliable than an eye inspection of the bands, whereby a certain number of grubs are generally allowed to escape unnoticed. On going over the trees, when the bandages are removed, a pointed probe should be used to search out all grubs which may have secreted themselves under pieces of bark, or eaten for themselves a hiding-place into the bark, broken branches, forks of the limbs, or old scars—as they prefer such places to the bands. Two bands, one over the other, are sometimes used, as some of the grubs, at times, crawl over the first in search of a hiding-place more to their liking.

Although bands answer a good purpose, they must be applied to other kinds of trees, and even to fencing posts around apple, pear, and quince trees, to do all the good which may be expected from them.

Mr. George Compère, who has done valuable work in Australia and China for the State Board of Horticulture of California, and who is now attached to this Department, mentions another easy way of gathering and destroying the codlin grub in California. Long straw is lightly gathered about the trees in the summer, and then raked up into small heaps and set fire to.

#### *Natural Enemies and Parasites.*

12. Probably the greatest distributor of the codlin moth is the fruit-grower himself, and the compulsory spraying and bandaging

in force in Tasmania meet with many opponents, says Lea. "Firstly, from those people who object to being compelled to do anything; secondly, from those who think it useless; thirdly, from those who, on account of their orchard being lightly infested, think it is too expensive to bandage and spray hundreds, or perhaps thousands, of trees to catch a few grubs." That class of people will always be found in any community, and therefore it is to natural enemies and to enternal parasites of the codlin grub that we must look to in order to minimise the tax it levies on infested orchards. It is a fact worth noticing that, in those countries where the apple tree found its birth place, there nature has widely provided natural enemies, whose functions in life is to keep in check those insects which prey on the fruit. In America, in Australia, and in South Africa, where apples, although introduced, flourish as well, if not better than on the continent of Europe, the codlin moth was also introduced, but many of its natural enemies and parasites must have accidentally been left behind. The balance of nature has in consequence been disturbed, and the moth has been having it pretty well all its own way. Artificial means, such as fumigation, spraying, bandages, and quarantine laws have, no doubt, done good work, but gradually and surely the pest is spreading, and is getting more troublesome. In Devonshire, in Herefordshire, in Normandy and other localities famed for their apples all the world over, no fumigating, no spraying, no bandaging are practised, and yet there apple-growing continues to be a remunerative and a national industry. It is to these localities that the American, the South African, and the Australian apple-growers will have to look for help, in the shape of codlin parasites.

The Americans are now well impressed with this fact, and they are already out in the field collecting these parasites and enlisting them in their warfare against the moth.

What these natural enemies are is a question of considerable moment for the apple-growers, and a list is here given, many names of which are taken from Mr. A. M. Lea's report.

*Birds.*—Hens in an infested orchard pick up a great number of codlin grubs and tear them out of their cocoons; in fact they can easily be trained to follow those engaged in lifting the bandages, and are found to be of great assistance. In America, woodpeckers and robins unceasingly seek after these worms during the winter months. In Tasmania, goldfinches, crows, starlings, and sparrows eat enormous numbers of the grubs, the last two, however, in other ways prove themselves destructive birds. In Germany and other parts of Europe the tom-tits do good work.

*Mammals.*—Mice and rats and bats devour many of these insects.

*Insect enemies* are numerous; of these the internal parasites are amongst the most useful. They include three from Europe,



*Campoplex memorum*, *Pachymerus vulnerator*, and *Phygadenon brevis*.

When it was announced some time ago that a parasite of the codlin moth had been discovered by George Compère great interest was at once manifested by fruit-growers. The new parasite—or rather, two species of them—have been received by the State Horticultural Commissioner. At the request of “California Fruit Grower,” Mr. E. M. Ehrhorn makes a statement regarding these new parasite:—

*Parasite No. 1.*—The codlin moth parasite, which was discovered on the coast of Spain, by George Compère, an agent of the State Commission of Horticulture, has arrived. There are two species of the parasite. One is a very large one, preying on the larva or worm of the codlin moth. It is a wasp-like fly, with a very long ovipositor, so fitted that it can reach up under the loose bark and rout out the worms. It deposits its eggs on the worm of the moth, and then gives the worm several quick, fierce jabs with its spear-like ovipositor to kill it. The larva of the parasite then uses the carcass to feed upon.

*Parasite No. 2.*—What parasite No. 1 misses the smaller one sent attacks, as the codlin moth has passed into the pupa form, and this small parasite lays its eggs in this form of the insect. As high as fifteen of these little parasites have been hatched from a single codlin moth. Both species have been received, and are now in the breeding cases.

*The Work in Spain.*—In the section whence these parasites were sent the codlin moth is so scarce that it is hardly noticed, the per cent. of wormy apples being only from three to five per cent. Hundreds of old apple trees are hanging full of beautiful apples, and not a single codlin moth can be found, although nothing has been done to prevent the insects from spreading, and it has been known in that section for thirty years.

Hair worms (*Gordius*) have been seen in grubs in the United States of America and Europe. From the United States a small wasp (*Trichogramma pretiosa*) is parasitic on the eggs. An Ichneumon (*Macrocentrus delicatus*), and a fly (*Hypostena variabilis*) are parasitic on the grubs when in the fruit; another Hymenopterous insect (*Goniozus*) is an external parasite, an Ichneumon (*Pimpla annulipes*) destroys the pupæ. In California, a wasp (*Sphecius Nevadensis*) “frequents pear trees, and is described as pulling the grubs out of the fruit with its fore foot,” says Slingerland. After the grubs have left the fruit more enemies beset them. In America three soldier beetles (*Chauliognatus Pennsylvanicus*, *C. marginata*, and *Telephorus bilineatus*) feed on grubs and pupæ as well also on a Neuropterous insect (*Rhapidia*), and other beetles destroy pupæ, viz., *Trogosita laticollis* and *T. corticalis*

In Tasmania and Australia two common soldier beetles (*Telephorus pulchellus* and *T. ruficollis*) eat grubs; the spotted ladybird (*Leis conformis*) devours young grubs and even pull these from the fruit when it is just starting boring; ground beetles, and among them (*Gnathaphanus pulcher*), one which occurs on the mainland; bugs of the genera *Reduvius* and *Pentatoma* destroy grubs sometimes even before these have left the fruit; even the much despised earwigs eat numbers of the grubs, and then afterwards will turn their attention to their excrements, and to the apple itself; spiders and centipedes eats the grubs, and the former the moths as well. Although a long list is here given of natural enemies of the codlin moth, nevertheless the fact remains that many more must exist, and also that they have proved themselves to be inadequate in their isolated efforts in appreciably keeping down the codlin moth. How far their introduction from distant parts and their concentration in codlin moth-infested localities will prove effectual in combating that dreaded pest is a problem which awaits solution at the hands of economic entomologists." The key to their successful introduction would be in guarding against the introduction as well of the secondary parasites.

#### CURCULIO.

A weevil pest, seen for the first time in Western Australia at Dalgarpark, Mr. Godfrey Hester's property. It started some eighteen years ago around one or two trees, spreading (1906) centrifugally. Other members of the family are:—

*Orthorrhinus Kluggi*, Sch.—The vine curculio. French, Part III., page 58.

*Leptos Hopei*.—The Victorian apple root-borer.

*Desiantha Maculata*.—The strawberry curculio.

*Conotrachelus Nenuphar*, Herbst.—The plum curculio of Europe and of America.

*Otiorhynchus sulcatus*, Fab.—The bud curculio, which is here mentioned. (According to Lea, it should be *O. cribricollis* as *O. sulcatus* as a larger and darker species with distinct spots on the scale. It is almost omnivorous, and attacks the twigs and buds and also the leaves of a number of plants. Miss Ormerod says the full grown insect is five-sixteenths of an inch from tip of snout to the end of wing cases, and one-eighth of an inch wide.

The eggs are laid a little below the surface of the soil; the maggots or larvæ are legless, whitish, somewhat hairy, and occur from about August to the following Spring at the roots of the food plants. The pupa is yellowish white, with brownish hairs, found about April, three or four inches below the surface of the ground, and remain thus a fortnight. The weevils are four or five lines in length, of a

dull black colour. The body between the head and the abdomen is granulated, and the wing cases are rough, with several raised lines and spotted with pale hairy tufts, and like other species of *O.*, it has no wings.

In Australia, these beetles appear in the growing season, about November, and decrease about Christmas, and cease in March. The leaves are first serrated, then the bark is gnawed off in patches, and ultimately the branch may be defoliated. The beetles emerge from the ground at night and set to work.

Mr. Geo. Wickens reported in 1906 that—"Fowls scratch most diligently around the trees infested by curculios. The beetles remain only an inch or two below the surface during the day, can neither fly nor hop. When infesting an orchard they spread slowly from tree to tree; thus their habit render them an easy prey to poultry.

The pest can only be checked by jarring the trees, and catching the beetles as they fall upon outspread canvas. Catching them over woolly bands immersed with a sticky substance on the outside. Dusting the trees while they are damp with Paris green and flour, arsenical sprays.

#### CUT WORMS.

These, *Agrotis munda* and other species, are the larvæ or grubs of moths belonging to the family *Noctuidæ*, and they are especially destructive during the night, in the day remaining concealed just under the surface of the ground, or under logs, rubbish, etc. There are numerous kinds in this State; some are peculiar to it, and others are almost world-wide in their distribution. The

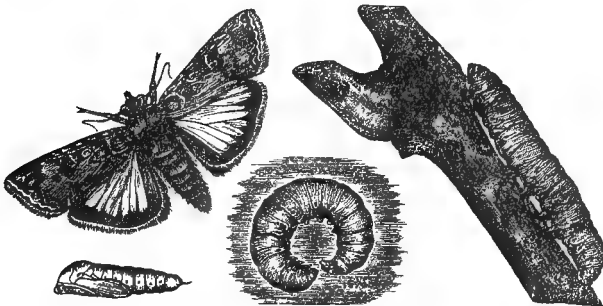

accompanying illustration (by Claude Fuller) shows one of the most common and destructive species, in its various stages. The larvæ, as evening approaches, remove themselves from the soil and crawl up the nearest plant or young vine, nibbling small pieces of bark as they proceed; they eat parts of the buds, and cause dis-

torted growth, or perhaps entirely destroy the young shoot; leaves are also attacked, but the grubs appear to prefer the soft young bark and buds.

Besides the vine this insect attacks the apple, quince, peach, and many other fruit, grasses and wild plants; sometimes a plant is entirely denuded of its leaves, or left with a few stalks and fragments of leaves. A tree or vine is occasionally practically ring-barked from the numerous patches that have been eaten. They hibernate in the soil and come forth in the spring in search of food.

The larva is thick and fleshy, and larger near the head than towards the tail. On being touched it curls itself up and feigns death; after a short period it straightens itself, and moves along by contracting the high segments and elongating the front ones, the motion being somewhat jerky. It is of a dirty sandy brown colour, with a feeble stripe running along the back, and two still more feeble ones at the sides; the head is shining, the under-surface is of a dirty grey colour, and paler than above. There are five pairs of prolegs placed on the apical segments; the breathing holes (or spiracles) at the sides are small, black and distinct. The body is almost without hairs, a few short ones being situated near the anus and on the sides. The excrement is black. In captivity the larvæ will frequently devour one another, even when supplied with an abundance of food. The pupæ are pale brown in colour, with a small spine at the end; they are usually to be found in the situation as the larvæ, and are usually (but not always) enclosed in a small silken cocoon, which is generally densely covered with sand and easily broken; around the wall of the residence on Rottneest Island I noticed, in the early summer, that cocoons of this species were clustered in lumps of from five to 20; they broke to pieces almost at a touch and the enclosed pupæ fell out. The moth itself measures about an inch across the expanded wings, the front ones are pale brown in colour, and mottled with darker brown and grey, the hind wings are almost white, with brown shadings towards the edges, the ribs (or veins) are brown, and the outer fringe of hairs is white. The egg is small, clustered on the bark; sometimes they are laid in rows, or occasionally scattered here and there.

There are several parasites that hunt and destroy the larvæ, the most plentiful being a moderately large Chalcid wasp: there are also two species of Ichneumon, and several flies.

*Remedies.*—Bait poison, No. 16. Caution: Great care must be taken that fowls and stock do not get at the bait.

#### HAWK MOTHS (*Chaerocampa celerio* and others).

The larvæ of several species of sphinx moths feed on the leaves of the grape vine. Some of these moths are very handsome, and with wings expanded will measure from two to four inches

across, and are a brownish grey colour, with brown variegations, with brown and pink spots. The moths deposit their eggs on the under surface of the leaves; after hatching, the larvæ feeds on the leaves, and grow rapidly until they obtain their full growth, when those of some species will measure three or four inches in length. They vary in colour, generally green, with golden yellow or reddish spots and stripes, and usually with a horn on the hind end of the

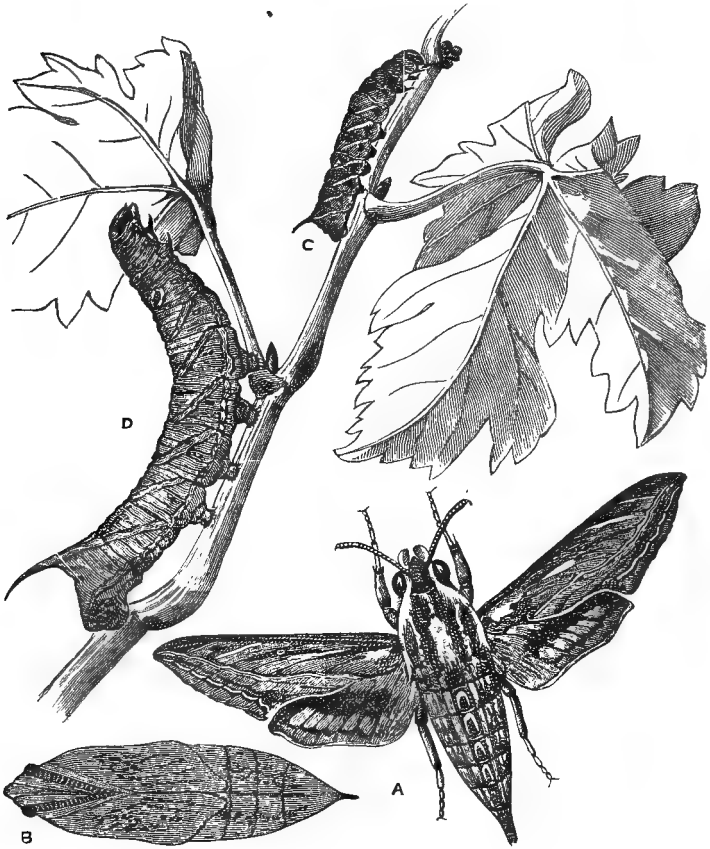

*a* Sphinx moth with wings expanded. *b* Pupa or chrysalis. *c* Young caterpillar.  
*d* Full-grown caterpillar in act of feeding.

body. When fully grown they descend, some entering the earth, and some creep beneath some leaves or other rubbish where they undergo their transformation.

Remedy: Spray with No. 13. Hand picking is the-most successful.

THE LEAF MINER (*Phytomyza* sp.)

A pest world-wide in its distribution. The eggs are laid on the leaves, usually on the under surface. The maggot on hatching out drills its way between the two skins of the leaves, becomes full fed in less than a fortnight, then changes to the pupal form, and a few days later to a fly. There are many broods in a season. The tunnels made by the maggots show up white in the leaves and are often so numerous that more than half of a leaf is affected and a perfect network of tracks appear. On holding the leaf to the light, maggots are seen, very small and the pupæ look like elongated seeds. The flies are very small, their bodies being hardly larger than the head of a pin. Attacks the milk thistle, marguerite, cineraria, sunflowers, geraniums, chrysanthemum, dahlia, lettuce, celery, parsnips, peas, tobacco, nasturtium, Cape weed, dandelion, sweet potatoes. I found sublimed sulphur of some use. A. M. Lea says no known spray is of any use, but pick out and burn the leaves.

## EELWORMS OR GALLWORMS.

A small nematode of the genus *Tylenchus*, sometimes confused with "scab." Rounded swellings from the size of a pin to the size of a pea appear on the roots. The eggs, after the decay of potatoes, etc., can withstand long periods of dessication and, given suitable conditions, can resume normal activities even after three or more years.

Other plants than potatoes, viz. bananas, onions, beetroot, clover, oats, wheat, etc., can be attacked, and all classes of soil can carry them—generally worse in fairly wet ground.

The remedies consist in—

1. Rotation.
2. Destroy the refuse of affected crops.
3. Clean seeds.
4. Kainit and sulphate of potash retard eelworms.
5. Sow a trap crop of beet which can be pulled up when attacked.

PEAR AND CHERRY SLUG (*Selandria cerasi*).

This is a small black saw-fly, measuring about a third of an inch in length, with two pairs of transparent wings, short antennæ, and short, thick-set body, which is furnished in the females with a fine saw-like appendage (from which this group of wasps take their popular name) with which it cuts a slit in the leaf and deposits from a dozen to eighteen eggs beneath the epidermis. In a few days the small, legless, olive-green, slug-like grubs emerge, and commence to feed upon the upper surface of the leaf, which they soon destroy. When fully grown they measure half an inch in

length, and have a rounded oval head and thorax, with the body much more slender, and cover themselves with a dark olive secretion that gives them a very slimy slug-like appearance.

They pupate in the soil beneath the tree when full grown, forming a stout chrysalid, the perfect saw-flies emerging in about six weeks' time.

This is a pest introduced from America, where it does a great deal of damage to pear, cherry, and other foliage in its larval state. It is also regarded as a very serious pest in Victoria, but in this State does not do very much damage, and is easily destroyed.

It is very partial to the hawthorn, and when hawthorn hedges exist it spreads rapidly.—(*Agricultural Gazette* of New South Wales: Froggatt.)

*Remedy.*—Wait till slugs appear, and then use Nos. 11, 12, or 13 (see p. 528).

Dusting the foliage with lime is one of the cheapest and best remedies, as the lime sticks to the slimy coat of the grubs and soon destroys them.

Where they are found to be very destructive to the foliage it would be advisable to disturb the soil round the trunk of the trees, or treat them with lime, so as to destroy the cocoons in the ground.

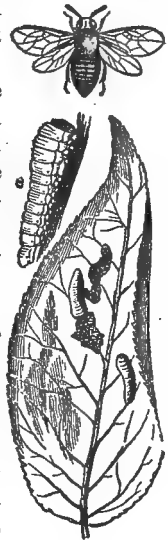

#### PEAR LEAF BLISTER MITE (*Phytoptus pyri*, Scheuton).

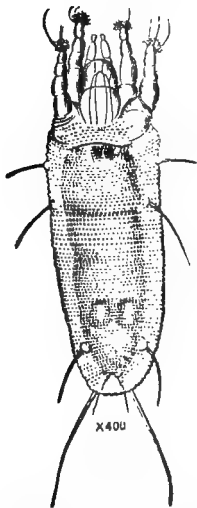

Pear Leaf Mite (under the microscope).

This remarkable little mite is hardly visible to the naked eye, but the galls it produces on the under surface of the leaves are generally rounded, measuring under one-eighth of an inch in diameter, but where the foliage is badly infected, coalescing and forming a bigger blotch. These galls always have an opening about the centre on the under side, so that the mites can escape on to the buds before the leaves fall. This is a very curious, elongated, cylindrical creature, with only two pairs of legs, head tapering in front, and transparent in colour. Opinions vary as to the amount of damage that this mite does to the trees they infest, but there is no doubt that they render the leaves very unsightly, and by causing them to fall before their time denude the tree so that the sun will affect it, and when the galls are abundant the crop of fruit will be reduced.—(*Agricultural Gazette* of New South Wales; Froggatt.)

*Remedy.*—Clean cultivation. In winter, dress limbs with No. 6; later on, 15 (see pp. 527-529), or powdered sulphur. Two or three dressings during spring and early summer.

#### POTATO MOTH (*Lita Solanella*, Boisd).

A. M. Lea, writing of this pest in the *Agricultural Journal*, August, 1895, states that this is perhaps the worst insect pest the potato-growers have to contend against, and says, where in numbers, it will not infrequently destroy almost the entire crop, its tunnels filled with excrement going through the tubers in all directions and rendering them unfit for human consumption; it also attacks and does very considerable damage to the leaves of tobacco, and is occasionally seen in tomatoes.

Seed potatoes often suffer very severely, the larvæ bore their way into the eyes and entirely destroy their germinating power. It is not only that the tubers are attacked, the larvæ preferring the leaves to the tubers, as where tubers have been accidentally exposed they had been seldom found to be attacked, whilst the leaves were swarming with the larvæ. When the tops die off or are cut down by frosts, however, a change takes place, as the larvæ desert the leaves in large numbers and wander about the fields, entering any tubers they may come across, even entering frostbitten ones. In captivity they will attack fresh leaves in preference to the tubers. It is therefore manifest that the crop should be dug before the tops become so dry as to drive the potato-moth caterpillars down to the tubers. Bag the potatoes before night, the moth being nocturnal and laying her eggs when dusk comes. Do not place haulms or tops in the mouths of the bags as is often done.

When depositing her eggs on growing plants the moth usually places them close together on the inner side of a leaf, close to the main or one of the smaller ribs; the larva on hatching immediately eats its way into the leaf, hollowing it out in patches, and leaving only the skins of the leaf, which then presents a patchy appearance; the larvæ will often leave one part of a leaf to go to another, and it is in eating their way in, that numbers may be poisoned.

The larva is a small, pale, dirty-green caterpillar, with a brown head, and when full grown is about half an inch in length. The pupa or chrysalis is pale brown in colour, and is enclosed in a small silken cocoon, which is nearly always covered with dirt. The moth itself is a small grey insect (the front wings darker than the hind ones), a little more than half an inch across the expanded wings.

*Remedies.*—Sprinkle with No. 13. Store underground if possible. Three ounces in 10 gallons of water.

A parasitic ichneumon wasp is reported from the Cape by Loundsberry.



The most important are preventive measures in dealing with this potato pest. See that the seed is free from grub or eggs. Always destroy all grubs in infested potatoes, and burn all haulms as soon as possible after the crop is dug. Never leave "wormy potatoes" lying about.

At the Hamel State Farm, Mr. F. Berthoud dusts his stored seed potatoes with sulphur, hydrated lime with a little Paris green added.

L. J. Newman, Government Entomologist, recommends fumigating stored potatoes at once with carbon bisulphide, 2lbs. per 1,000 cubic feet of space, for 48 hours, repeating the treatment again six to eight days later when the eggs have hatched. An airtight fumigating tent made of a wooden framework 10ft. x 10ft. x 10ft., or 1,000 cubic feet, will accommodate 120 to 150 bags of potatoes. Over this framework fasten tough canvas or hessian painted with a whitewash and covered with tarred paper or sized paper. Soil is thrown up around the base. A more permanent moth-proof room with fly-proof wire door and window may be put up where potato growing forms part of the farm operations.

#### THE RED MITE (*Bryobia pratensis*, Garman).

From April to early summer a reddish tint will be frequently noticed upon the bark of both apple and pear trees, but chiefly the latter; sometimes, when the trees are badly infested, even the stakes are thickly covered. Upon examination with a lens, it will be found that this is caused by countless numbers of tiny, round, crimson eggs, clustered together in every curve or irregularity in the bark.

Later on, when the buds burst out into leaf, these little creatures hatch, leaving an empty white shell behind, attack the leaves from the underside, sucking up the juice of the tree, and causing them to become mottled and fall off prematurely.

This mite is about twice the size of the "red spider," of a bright red colour, with four pairs of legs, the front pair much longer than the hind ones.

Heavy rains seem to destroy great numbers, and though this pest is so common and numerous in many orchards in some parts of the State, it does not seem to make much headway or do much damage in this country, yet in some parts of America it is looked upon as very destructive to fruit trees.

*Remedy.*—Clean cultivation. In winter, dress limbs with No. 6; later on, 15 or powdered sulphur. Two or three dressings during spring and early summer. The sulphuring is best done early in the morning if applied dry, being then less inconvenient to the

men, and also because the powder adheres better on the leaves when the dew is on.

Sulphur, although the essential ingredient for either oïdium on the vines or for mites and red spider or thrips on orchard and garden plants is best mixed with hydrated lime, which occupies a position between air slaked and quicklime. "Hydrated lime" is prepared by adding water and quicklime in the proportion of 1 to 3 and mixing thoroughly with a long hoe. When mixed with fine sulphur it acts as a diluent, a carrier, and an adhesive material. The dust blown into the tree or plant has more far-reaching effect than when the material is applied wet by means of the spray pump.

#### RED SPIDER (*Tetranychus telarius*).

It is a misnomer to call this insect a spider, as in reality it is a mite and possesses only six legs at first. The colour which it assumes seems to depend greatly on the sort of food it is living on. It has been called a spider simply from the webs which it spins over the trunks and branches and under the leaves, giving a glassy appearance to the surface. These mites are able to move quickly over this web. Some times they are to be found in masses, a quarter of an inch thick, on the underside of the leaves. They are almost omnivorous, and attack not merely hops, but apples, almonds, and vegetables of all sorts. The eggs are attached to the webs, and can easily be detached by brushing with a hard brush. Let it be borne in mind that as the mites congregate on the underside of the leaves, spraying is always difficult and more or less unsatisfactory; if, therefore,

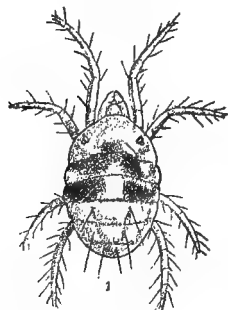

Red Spider (*Tetranychus* or *telarius*.)

they can be attacked before the leaves burst, and while the eggs are clustered on the trunk and in the crevices of the bark, there will be a much better chance of destroying them. I find the red spider on apples, pears, plums, apricots, hops, beans of all sorts, roses, and some other garden flowers. The eggs are sometimes quite reddish, while at other times I have noticed that they were colourless. The so-called spiders are very small, not much bigger than a large full-stop.

In some countries this so-called red spider does a great amount of damage to lemon and almond trees, but in this country it has seldom, if ever, caused any serious damage to fruit trees, it being destroyed by the little ladybird (*Symnus vagans*).

*Treatment.*—The same as for red mite.

RUTHERGLEN or FALSE CHINCH BUG (*Nysius vinitor*, Gergroth).*Description and Life History.*

Mr. Froggatt, in writing on this pest in the New South Wales *Agricultural Gazette*, says:—"Small plant bugs, which every few seasons appear in great numbers among the weeds and rubbish in the fields, and when fully developed attack the fruit, pricking it with their sharp tubular mouths, and causing the fruit to become spotted, and finally fall to the ground. These bugs are small gray creatures, about  $1\frac{1}{2}$  lines in length when full grown, of a general grayish brown colour; the eyes large and rounded; the forehead rather pointed; and the antennæ long, composed of four joints, the basal one short and thick; the thorax is narrow behind the eyes, but broader at the base of the wings; the legs long and slender, with the tarsi rather black; the wings are semi-transparent, with a few dark lines showing when closed.

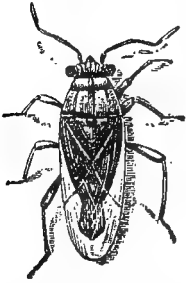

Rutherglen Bug (*Nysius vinitor*).

"They are very active little creatures, running to shelter when disturbed on the ground, and if upon the tree, flying off as soon as it is touched, so that they are not easily destroyed. Very little is known about their earlier stages, but the eggs are said to be deposited about the trunks of the trees, close to the ground. This bug is said, besides damaging this and other fruit, to do considerable damage to tomato and potato fields by destroying the foliage, but the entomologist could never find conclusive proof that this was the case.

"*Treatment.*—In the Liverpool district several orchardists minimise this pest, to a great extent, by going round early in the morning and shaking each branch over a large shallow dish containing a little kerosene and water, into which they fall and are smothered. This, however, would not be practicable in a large orchard badly infested.

"Spraying with tobacco wash (see p. 527) has also been found to be effective.

"*Remedy.*—Spray with Quibbel's liquid disinfectant— $\frac{3}{4}$  oz. in one gallon of water."

## SCALE INSECTS.

These belong to the family *Coccidae*, and include the mealy bugs. The scale bug or bark lice in this family include some of the most serious pests with which the horticulturist has to deal. Scarcely any kind of fruit is free from their attacks. The ease with which

these insects or their eggs can be transported long distances while yet alive, on fruit or living plants, has caused many species that infest cultivated plants to become world-wide in distribution, and some have found their way into this State, and it is only those that have that will be dealt with in this book.

In general outward appearance the female insects present very variable forms. They may be either naked or covered over with some kind of a shield, which may be fibrous, or waxy, or cottony; or they may have simply a thin, powdery meal scattered over them. The covered insects are, of course, stationary, although in some cases, before reaching their full development, they move about, carrying their covers with them. The naked insect may be either stationary or active.

They attach themselves either to the bark or the stem of a plant or to the leaves. In the latter case they are seldom found on the upper side, but on turning the leaf over the under surface is frequently found covered thickly with them.

In many cases they exude, in the form of minute globules, a whitish, thick, gummy secretion, answering probably to the "honeydew" of the *Aphididae*. This secretion drops from them to the plant, and from it grows a black fungus (*Fumago salicina*), which soon gives an unsightly appearance to the plant. This fungus or "smut" is an almost invariable indication that a plant is attacked by insects, and may, indeed, give a useful warning to growers. It is not, however, produced in appreciable quantities by all species.

Some species lay eggs, while others bring forth their young alive. Some species are covered with a hard shell, and others with a soft. So that an intelligent appreciation of the life history and habits of these scale insects is necessary to enable any one to select and apply, with any probability of success, a remedy.

Once scale insects have established themselves in an orchard it becomes most difficult to eradicate them. It is easy, however, to check their spread and to keep the trees in a clean and healthy condition. Our experience of introduced scale parasites has given the most satisfactory results in combating the pest.

#### BROWN GRAPE SCALE (*Lecanium cymbiform*, Sign.).

This scale was first observed in this State about ten years ago, infesting the grape vines in the vicinity of Perth. The adult female, in colour, is light brownish, and not unlike *Lecanium hesperidum* in shape, but is very much larger. Like other species of *Lecanium* that produce only one generation a year, their development is slow. The larvæ, when first hatched, are a pale yellow in colour, and at once locate upon the leaves, their development being slow until they take up their position upon the young cane or stem

of the plant, where they remain throughout the winter, and in fact the balance of their lives; upon the ascent of the sap, in the spring, they grow rapidly. They appear to prefer the young canes, and are



Grape Vine attacked in the Spring by the Grape Scale.

often to be noticed clustering and incircling a cane for several feet. It has also been known to attack pear, peach, plum, and mulberry trees, but then only on trees that stood in close proximity to infested grape vines.

This scale, while new to this country, has been known to occur in Europe for more than a century, and was described by Signoret as occurring on grape vines in France.

*Remedies.*—In winter, use No. 10, 14, or 19 (*see pp. 528-530*).

*Natural Enemies.*—Soon after this scale had been identified in this State, steps were taken by the Department of Agriculture, through the agency of the travelling Entomologist, Mr. G. Compere, to seek for and introduce a parasite, a work which has been crowned with such satisfactory result that the scale, which threatened to become a troublesome one, has since made little or no progress.

BLACK SCALE (*Lecanium oleae*, Bernard).

A dark brown or blackish scale, which infests all varieties of citrus trees, and nearly all deciduous varieties, and many plants, shrubs, vines, etc., and is more generally found in the orchards and gardens of this State than any other species of *Coccidae*. The presence of this species can be readily detected by the appearance on the branches, foliage, and fruit of a black smut, known as *Fumago salicina*. This smut or fungus is caused by the honeydew exuded by the female scale.

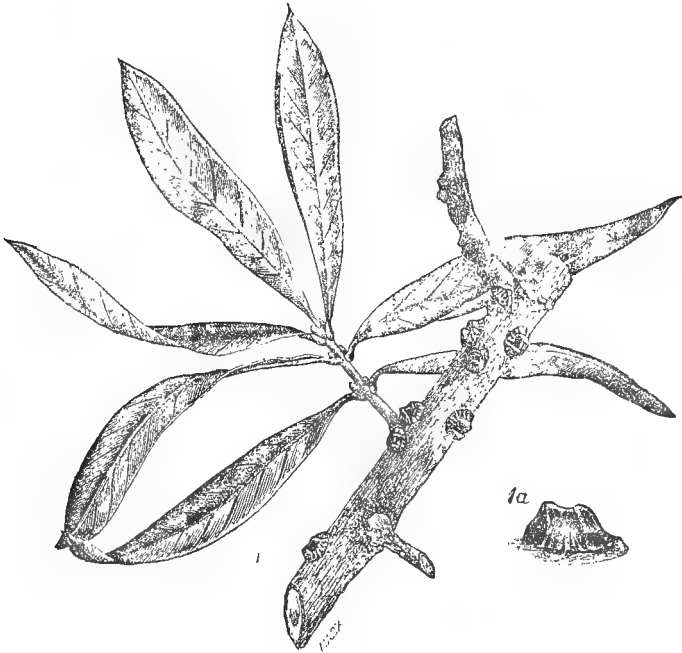

Black Scale (*Lecanium oleae*.)

The best treatment for this scale is fumigation with No. 18. Spraying with No. 10, 14, or 19 is excellent to check their spread, and to keep plants in a clean, healthy condition. The application of these remedies should not be made, however, while the scale are in the adult stage, as it will have little or no effect upon them, but should be done while they are yet in their larval stage.

*Natural Enemies*.—Some twelve years ago three species of parasites were introduced successfully into this State, and have now become established: *Dilophogaster californica*, *Hemencyotus crawii*,

and *Myiocneme Comperei*. The first two mentioned are parasites upon the eggs, while the last-mentioned is upon the scale itself.

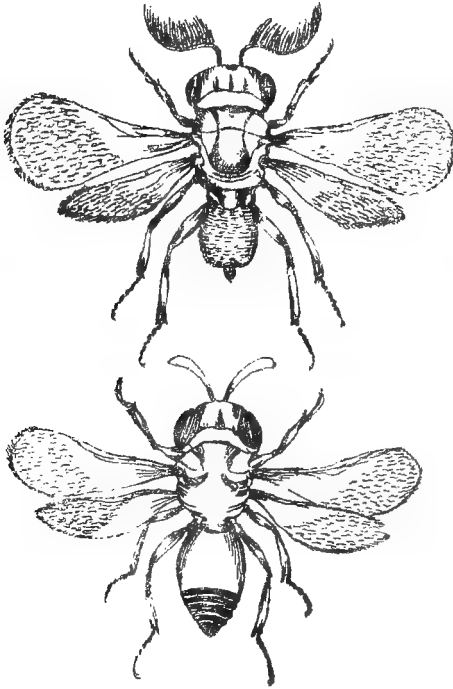

Black Scale Parasite (*Dilophogaster californica*).  
Male and Female. Upper, male.

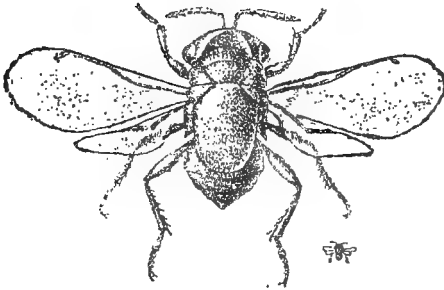

Black Scale Parasite (*Scutellista cyanea*).

The best and most effectual parasite of this pest has not as yet been established in this State, viz., *Scutellista cyanea*. This has kept the black scale in subjection in Europe for more than a century past, and it is to be hoped that it will be established in this State also.

**BROWN OR SOFT SCALE (*Lecanium hesperidum*).**

This scale differs from the black scale; it is much smaller, flatter, and has not the strong ribs so distinctive of that species.

Its food plants are about the same as those of the black, and the results of its attacks upon plants are similar to that of the black scale. It succumbs much more readily to treatment than does the black scale, its covering not being so hard, and it is besides "viviparous."

*Remedies.*—Nos. 18, 10, 14, or 19 (see pp. 528-530). Of these, resin and soda wash give very satisfactory results.

*Natural Enemies.*—Two species of parasites, yet unnamed, have been successfully established in this State.

#### SAN JOSE SCALE (*Aspidiotus perniciosus*).

This is, no doubt, the most destructive scale insect which attacks deciduous trees; it appears to be most destructive to

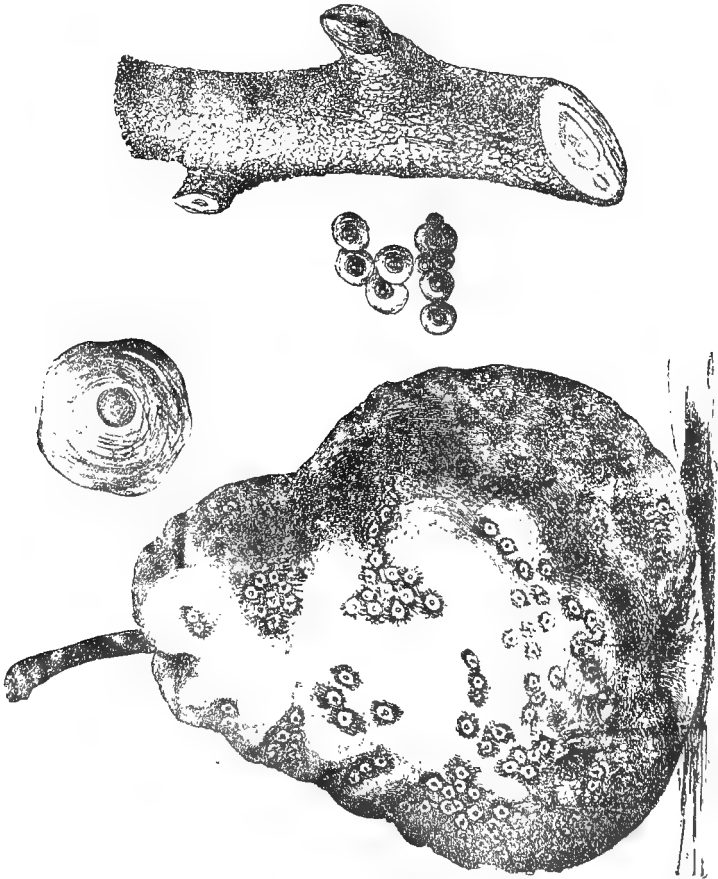

Fruit and branch infested with San Jose Scale; and enlarged scale. (After Howard.)



apple, pear, and peach. This scale is not striking in appearance, and would easily escape notice in an orchard. When once intro-

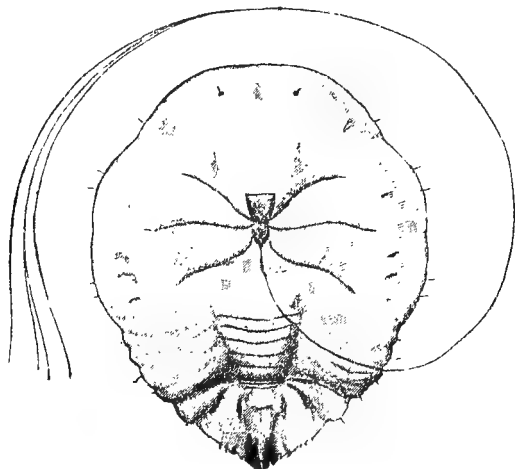

Female of the San Jose Scale.

duced into an orchard its spread is very rapid, and if not checked will soon cause the death of the plants attacked. It attacks stem,

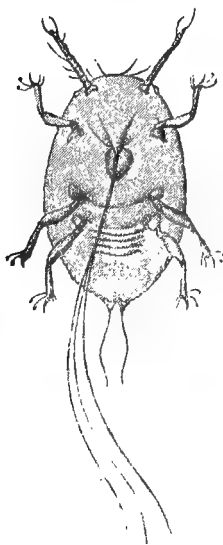

Young larva of the San Jose Scale. (Enlarged.)

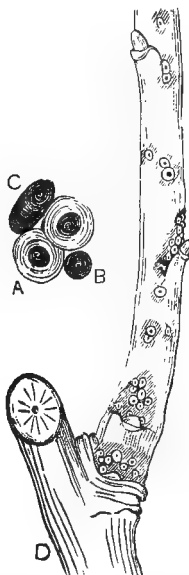

A The male scale. C The half-grown female scales. B In badly infested case D Showing peculiar red band which it produces on fruit and branches. (After Fuller).

leaves, branches, and fruit; but only in severe cases is it to be noticed upon the leaves. A peculiar feature of this scale is the reddish discolouration around the margin of each female. This encircling ring of reddish discolouration is very noticeable on fruits, especially pears. Fruits severely attacked become distorted, rough, and pitted, sometimes cracking, and becoming unmarketable. The cambium layer of young twigs, where the scales are located, is usually stained deep red or purplish, and when the scale is only scatteringly present the distinctive purplish ring surrounding each scale is almost as noticeable on young twigs as on the fruit, and is of the greatest service in facilitating the inspection of trees which have been exposed to contagion. The young scale might easily elude the most careful inspection, but the striking reddish discolouration makes them comparatively conspicuous objects.

This, like all the armoured *Coccidae*, pass their life under the protection of the waxy scale, except during a few hours while active in the larval stage, and an equally brief existence of the males in their winged stage.

The long period during which the females are continually producing young, during the summer months, has an important bearing on the question of remedies employed in its destruction.

*Description.*—The scale of the female is circular, and in colour blackish gray, excepting the exuviae in the centre, which is of a deep straw colour; sometimes it has a reddish hue; it measures from one to one and a-quarter lines in diameter. The scale of the

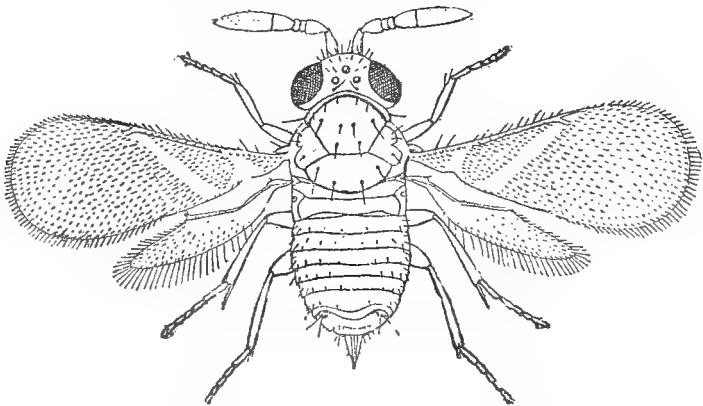

*Aphelinus fuscipennis*—The Parasite which holds the San Jose Scale in check in California.

males is oval in outline, and nearly black with the exuviae between the centre and anterior margin of the scale, but is much darker in colour, and more obscure, than that of the females.

*Remedies.*—In winter, three applications at frequent intervals, if necessary, using Nos. 6, 10, 14, or 20 (see pp. 527-530); or the hydrocyanic gas treatment, No. 18. A spray of mustard water, 1lb. to 20 gallons of water, is reported to kill the San Jose scale in the foliage season.

*Natural Enemies.*—In California this scale is now held in complete subjection by a small chalcid fly (*Aphelinus fuscipennis*). At horticultural conventions held in that State twenty odd years ago,

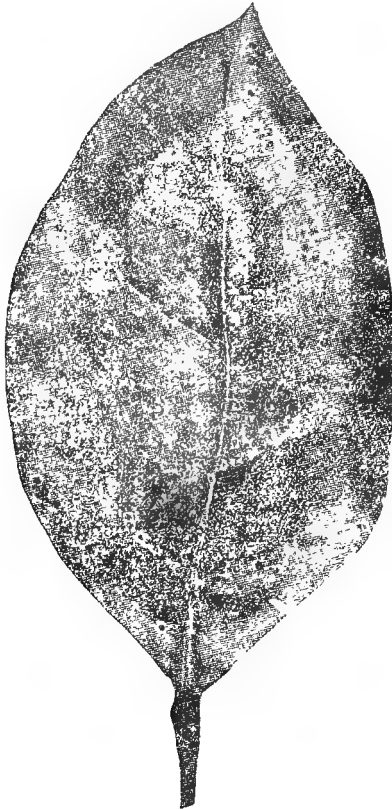

Orange leaf infested with Red Scale (*Aspidiotus aurantii*).

the question of dealing with the San Jose scale was one of their most serious problems, but now it is seldom if ever referred to at such conventions.

RED SCALE (*Aspidiotus aurantii*, Mask).

This was, until some years ago, the most serious scale insect which the citrus fruitgrowers of this State had to contend against. It has a very wide range of food plants, and attacks all varieties of citrus fruits, and is often noticed attacking the quince, guava, pear, fig, loquat, mulberry, castor bean and rose as well as many other garden plants and shrubs. Leaves, fruits, and branches are attacked;

and it occurs at times so thick upon the fruit of orange and lemon that its market value is destroyed. This scale belongs to the "armoured" ones.

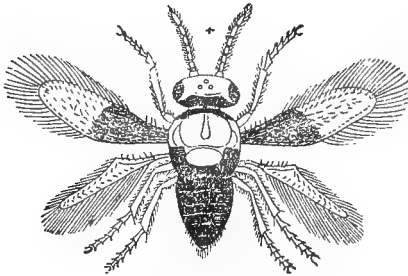

Red Scale Parasite. (Enlarged.)

*Description.*—The colour of the female, when scale is formed, is light or primrose yellow, but as it reaches maturity it becomes a brownish yellow.

The formation of the body is such that under the scale, when examined with a lens, its appearance is that of a broken ring, but when ovipositing, the posterior end of the abdomen extends beyond the circular line of the body. The colour of the natural insect is shown through the nearly transparent scale from which it derives its common name—Red Scale.

*Remedies.*—Use, during the summer months, Nos. 10, 14, 20, or fumigate with No. 18 (see pp. 528-531). The latter has given the best results.

*Natural Enemies.*—California made a long and continuous search for the parasite of this scale, but it was not discovered until 1900, when it was found in China by Mr. Geo. Compère, and from there sent to California, where they were liberated in an orange grove well infested with red scale, and, notwithstanding that the owner of the grove promised the officers of the State Board of Horticulture that he would not spray or fumigate the trees in order to give the little parasite a chance to become established, this promise, says Mr. Compère, the owner kept, so far as the spraying or fumigation, but turned to and cut out the trees and burned them, with no explanation to offer for his action, only that he had not promised not to burn the trees.

During a subsequent visit of our entomologist to China in 1905, only a few scattered specimens of the red scale were to be found;

these were sent to this State and from them a few specimens of the parasite were bred and liberated.

A parasite of the red scale—a tiny chalcid wasp—has now established itself strongly in California, and also in Western Australia, where it was concurrently introduced from the same source. In February and March, 1906, swarms were found in scale-infested gardens in West Perth, and also near Kalamunda at Mr.

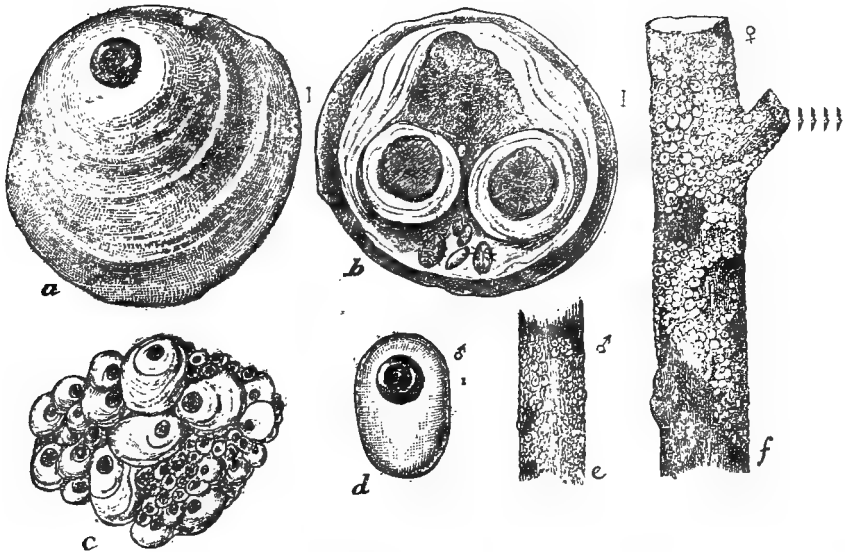

Greedy Scale.

*Aspidiotus rapak*: *a*, female scale from above; *b*, same from below; *c*, mass of scale as appearing on bark; *d*, male scale; *e*, male scale on twig; *f*, female scabs on twigs; *e* and *f*, natural size; *c*, considerably enlarged; *a*, *b*, *d*, greatly enlarged.—*Year Book*, U.S.A. Dep. of Agri., 1894.

Palmeteer's orchard, where a few specimens of the helpful parasite had been liberated. Since then they have been widely distributed by the Entomologist, Mr. J. L. Newman, and the Fruit Industries Branch of the Department of Agriculture, with most satisfactory results. Orange and lemon trees which some 10 to 15 years ago were fumigated every two or three years are now left severely alone, and are all the cleaner for not being interfered with, as it was found that fumigation was fairly efficacious but, when strong enough, destroyed along with the scale insects the young bud-carrying shoots, thereby throwing the trees back one season and causing the loss of one year's crop.

GREEDY SCALE (*Aspidiotus rapax*, Comstock).

This scale is found to attack a large variety of fruit-trees, plants, and shrubs, and is often noticed infesting the pear, peach, plum, apple, and apricot trees. Notwithstanding that this scale is usually found thickly covering the whole stem or branches of its food plants, it seldom causes any serious damage.

The scale of the female is nearly circular, or slightly oval, yellowish in colour when it covers a living, matured insect, but is generally a light grey. The full-grown specimens measure nearly one line in diameter, and its form is more convex than the other species of *Aspidiotus* referred to in these pages.

*Remedies.*—In winter, use Nos. 10, 14, 20, or fumigate with No. 18 (see p. 528).

*Natural Enemies.*—While yet no true parasite of the greedy scale has been discovered, yet there are a number of predaceous ladybirds in this State which feed upon it, and accomplish a great deal in reducing their numbers.

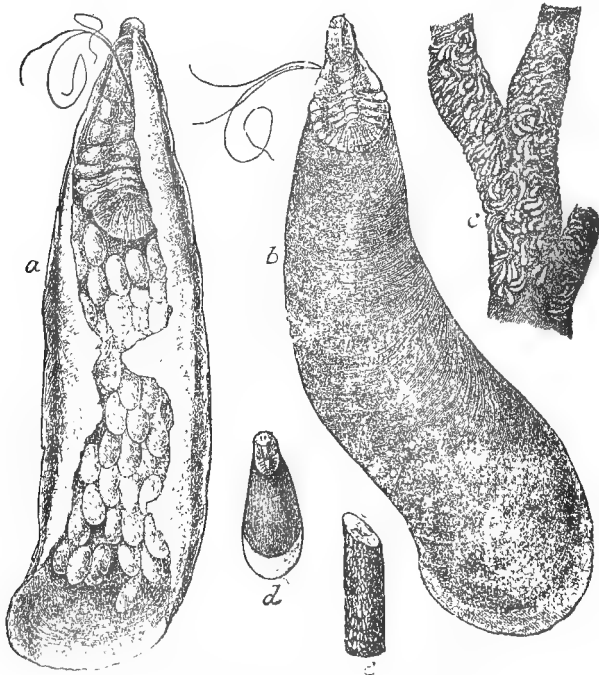

Mussel Scale of the Apple (*Mytilaspis pomorum*, Bouche).  
*Mytilaspis pomorum*: a and b, females enlarged; c, natural size; d, male enlarged; e, natural size After Dr. L. O. Howard.

**MUSSEL SCALE (*Mytilaspis pomorum*, Bouche).**

This scale insect is a serious pest of the apple trees in various parts of the world; it also infests the pear and other fruit-trees, but it displays a partiality for the apple.

This species can be readily distinguished from the other species of scale insects that infest apple trees, and mentioned elsewhere in these pages. The scale of the female is long and narrow, and more or less curved, and widened at the posterior end, and measures from

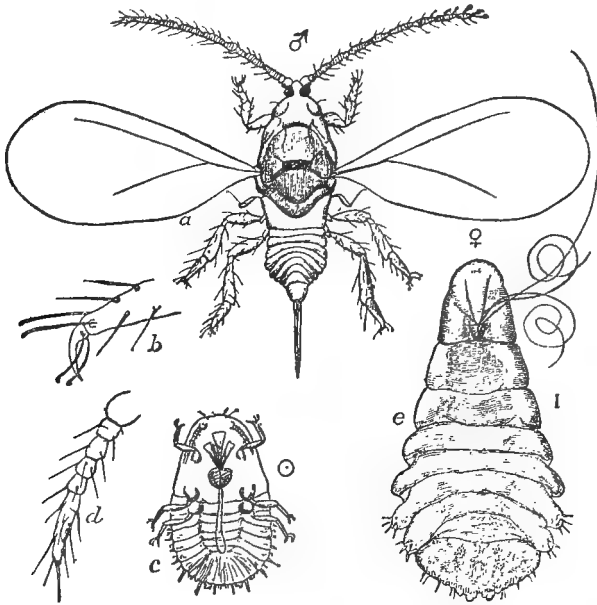

*Mytilaspis pomorum*: a, adult male; b, foot of same; c, young larva; d, antenna of same; e, adult female taken from scale; a, c, e, greatly enlarged; b, d, still more enlarged. (Year Book, U.S. Department of Agriculture 1894.)

one to one and a quarter lines in length. Colour, dark yellowish-brown. The scale of the male is smaller than that of the female, and nearly straight. It is not so dark in colour, and has a mottled appearance.

*Remedies.*—In winter months use Nos. 6, 10, 14, 20, or fumigate with No. 18 (see pp. 528-530).

Several parasitic fungi (*Microcera*, sp.) occur in Australia, and are reported to feed on the red scale of the orange (*Aspidiotus coccineus*); on an *Aspidiotus* of a eucalypt in Tasmania, and one (*M. mytilaspis*, McAlpine) feeds on a mussel scale of the eucalyptus.

*Aspidiotus Rossi*, Maskell.

This scale has no common name by which it is known, and very little attention is ever given to it, as it is seldom noticed upon any fruit-trees (olive excepted), but may be found in almost any garden or park in and around Perth, where it attacks many varieties of shrubs and other garden plants, and is very common on the oleander trees. Some writers claim that this is an indigenous species to Australia; but such is not the case.

*Remedies.*—Use Nos. 10, 14, 20, or fumigate with No. 18 (see pp. 528-530).

*Parlatoria zizyphi*, Lucas.

There is no common name which this scale insect is known by, and it was twenty years ago discovered in this State; but the trees upon which it was found were at once destroyed by burning them, so it may be hoped that the State is again free from this scale. In Italy it is one of the most serious pests of the citrus trees, and causes a great amount of damage. It had also at one time been a serious pest of the citrus trees of the Hawaiian Islands, but on the introduction of the Australian ladybird (*Orcus chalybeus*) to those islands it soon became a harmless form, and is no longer noticed there.

*Remedy.*—Fumigate with No. 18. Spraying against this scale has been of no use in Italy.

*Rhizococcus araucariae*, Maskell.

This coccus is a very common pest of the Norfolk Island pine (*Araucaria excelsior*), and a few years ago some trees in one of the gardens in Perth were found very badly infested with it; but the introduction of the ladybird (*Cryptoleamus montrouzieri*) from the Eastern States has rid the trees of this scale.

## STRAWBERRY BEETLES.

Between the rows sink, with the top flush with the ground, meat or jam tins half-filled with water sweetened with treacle or with honey. The beetles at night are attracted by the smell and tumble in; in the morning the tins are visited and the beetles taken out and destroyed. After a little while but few beetles are left.

In the autumn mow the plants (not too close, as not to hurt the crowns), rake off and burn. By so doing the homes of many pests are destroyed, and at the same time the leaf blight is checked.



Some pests from strawberry gardens at Kalamunda were, in 1904, reported by A. M. Lea to be—

1. *Desiantha maculata*, a small beetle that attacks cultivated plants and many wild oats all over Tasmania. (A note with a rough sketch appeared in W.A. *Journal of Agriculture*, Nov., 1897.)
2. A plant bug of the family *Lygaeidae*, an allied species here shown, is common in Tasmania, and is destructive to strawberries and other plants.
3. Larvæ of one of the chinch bugs — probably *Nysius Vinitor*.

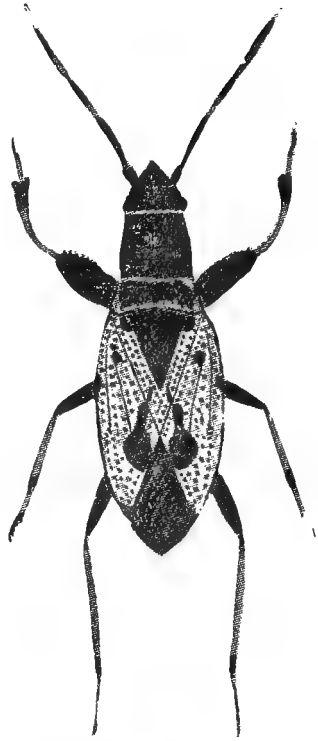

Strawberry Beetle.

WHITE COTTONY CUSHION SCALE  
(*Icerya purchasi*, Maskell).

Scattered specimens of this scale insect are often met with in this State. It has a very wide range of food plants, and has been

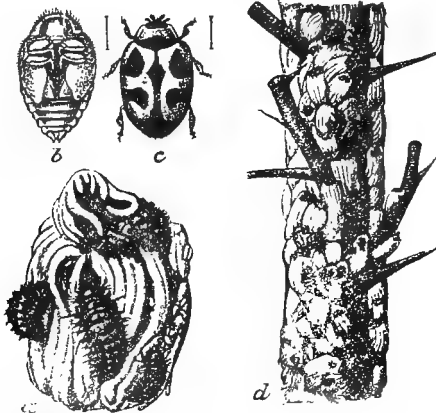

White Cottony Cushion Scale (*Icerya purchasi*, Maskell).  
*Icerya purchasi*—a, scale enlarged, showing larva of *Novius* at work; b, pupa of *Novius*; c, *Novius*; d, scale natural size (After C. L. Marlatt.)

a very serious pest in other parts of the world. In Australia, it has never been known to do any damage, being held in complete subjection by the little ladybird (*Novius cardinalis*) and an internal parasite (*Lestophonus iceryae*). This scale is indigenous to Australia.

*Remedy.*—The destruction of this scale should be left to its parasites.

MEALY BUG (*Dactylopius adonidum*, Linnæus).

Living upon various green-house plants, and often noticed on orange trees, it is very troublesome at times to indoor plants. The female, a small scale-like insect, *more or less covered with a whitish*, mealy powder, measures from one line and a quarter to a line and a half in length; is of a whitish or yellowish colour, with a brown band on the middle of the back, and is covered with a mealy powder, which is excreted through the pores situated on the various parts of the body. In addition to this there is a woolly border around the edge of the body, which is longest at the hind end of the body.

*Remedy.*—See page 624.

DESTRUCTIVE MEALY BUG (*Dactylopius destructor*, Comstock).

This, like *D. adonidum*, is found infesting green-house plants. It is a very destructive species to sugar-cane in some parts of the world. Scattered specimens are frequently met with in gardens in

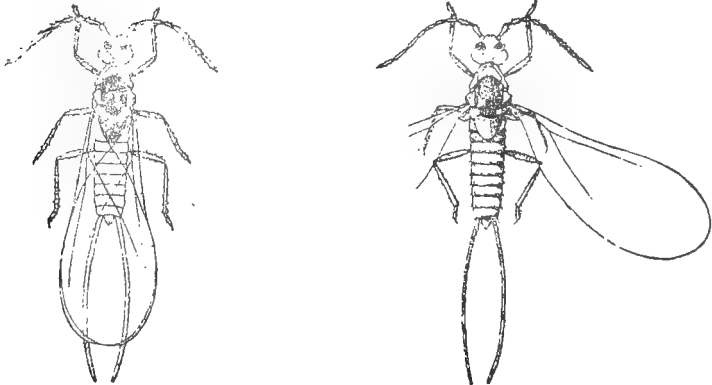

a. Male of *Dactylopius longifluc.*  
 a. With wings folded. b. One wing expanded.  
 Greatly enlarged. (Berlese.)

and around Perth. The female is a small yellowish bug, thinly covered with a mealy powder; nearly two lines in length.

*Remedy.*—See page 624.

LONG THREAD MEALY BUG (*Dactylopius longifilis*, Comstock).

In general appearance the female of this species does not differ much for *D. destructor*, only a little longer, and has four long white threads at the posterior end of the body; is found on green-house and garden plants.

*Remedy.*—See page 624.

ORANGE MEALY BUG (*Dactylopius citri*).

The female of this species is not unlike that of *D. adonidum* in appearance, but has not the brown band on the middle of the back, but becomes completely enveloped in a white mealy exudation. This, like the other species of mealy bugs, forms no external scale covering, the whitish mealy powder taking its place.

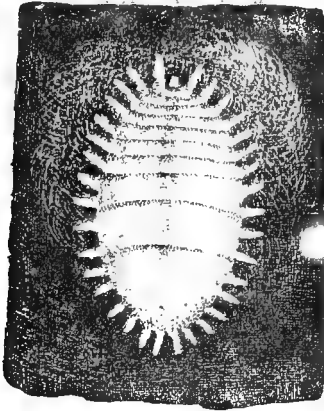

*Dactylopius citri*. Female enlarged. (After Berlese.)

This mealy bug, like most other species of mealy bugs, has a very wide range of food plants, and is a very serious pest of the lemon and orange trees, attacking both plant and fruit. In Italy, at the present time, it is one of the most serious pests with which the citrus fruit-growers have to contend, and causes a great amount of damage to the orange crop in some districts of that country. This pest has become well established in this State, but its spread has been arrested by the introduction of the ladybird (*Cryptoleamus montrouzieri*) and another unnamed form from Spain.

From the fact that these mealy bugs have no external scale covering, and being soft bodied, would lead one to believe that they could be easily destroyed; but such is not the case, as they have proven to successfully resist the deathly effects of the hydrocyanic gas fumes.

This mealy bug, like most other species of mealy bugs, has a very wide range of food plants, and is a very serious pest of the lemon and orange trees, attacking both plant and fruit. In Italy, at the present time, it is one of the most serious pests with which the citrus fruit-growers have to contend, and causes a

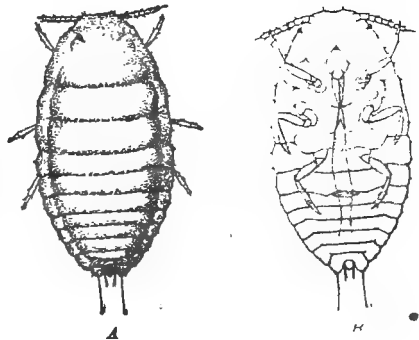

*Dactylopius citri*.  
a Front, b back view. (After Berlese.)

*Remedies.*—Spray with Nos. 7, 10, 14, or 15 (see page 528). In the open it is not likely that any spraying in the future will be necessary, but will in case of plants growing indoors, for when the ladybirds are liberated indoors they will at once fly to the light and try to make their escape, and are often exhausted and perish before they become reconciled to their confinement.

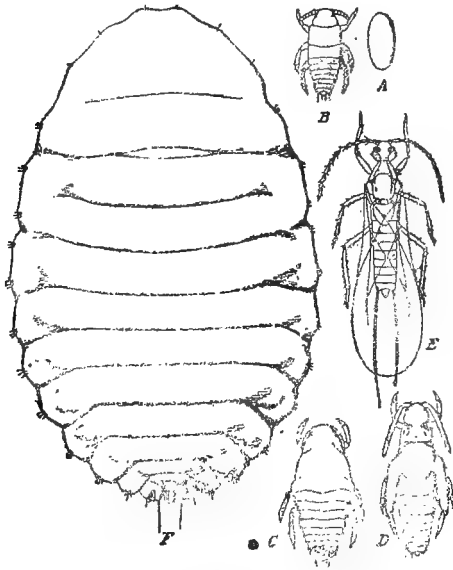

*Dactylopius citri.*

" , an egg ; *b*, larvæ ; *c*, first, *d*, second stage of male ; *e*, male ; *f*, dorsal view of female ; all greatly enlarged. (After Berlese).

#### SNAILS AND SLUGS.

Dust the plants with air-slaked lime with some tobacco dust added. Where fowls or ducks are not kept, arsenical bait placed about the garden is readily eaten, and is an excellent measure. Ducks are excellent scavengers where they can do no harm. Traps, such as boards or bags, placed over the moist ground and inspected in the morning, when the slugs are collected and thrown in a bucket with salt water.

#### THRIPS.

The members of this order have four wings: these are similar in form, very small—one twentieth to one twenty-fifth of an inch—long, narrow, membranous, not folded, with but few or no veins, and only rarely with cross veins; they are fringed with long hairs,

and are laid horizontally along the back when at rest. The metamorphosis is incomplete. The mouth parts are probably used chiefly for sucking; they are intermediate in form between those of the sucking and those of the biting insects—*i.e.*, they are fitted to pierce and to suck.

There are various species in this State, and some are very destructive to onion tops. Onions attacked by thrips will soon have a whitish appearance, and the onions themselves will often become stunted in growth. They also attack orange and lemon trees, feeding on both the upper and lower surface of the leaves, and giving



Cluster of oranges infested with *Dactylopius citri*.

to them a very whitish appearance. Where they appear they do some damage if early rains fail, as then the leaves become less juicy and palatable for them and they betake themselves to the fruit. They are extremely lively, leaping or taking flight with great agility. Some species eat other insects, but the most live upon vegetation.

Rain is the most formidable enemy of the thrips, so they are more in evidence in dry seasons. Spraying, especially with sulphides or with tobacco decoction, or, again, resin and soda wash will also act both mechanically in washing them off the plants by the million and killing them on account of the poisonous sulphur fumes.

*Remedy.*—Clean cultivation. For onions spray with No. 15, and destroy all tops as soon as crop is harvested. On fruit-trees spray with Nos. 10 or 14 (see p. 528). In the case of onions there are two obstacles to overcome; the very young thrips work very largely down about the base of the leaves. Owing to the peculiar growth of the plant, it is very difficult to reach them. One pound of whale oil soap, dissolved in 12 gallons of water, is also very effectual in destroying thrips. While in Spain the writer noticed the larvæ of a *Syrphus* fly feeding upon thrips infesting pear trees.

#### WIRE WORMS.

There are many species that feed upon the roots of various plants, and at times do considerable damage. These so-called worms are slim, and brown in colour. They are the larvæ of what are known as click beetles.

*Remedy.*—Use No. 16 bait (p. 530).

#### FRUIT FLY (*Ceratitis capitata*).

This is beyond question one of the most serious orchard pests which has yet found its way into this State. Other pests with which we have to deal can, to a certain extent, be destroyed by the use of artificial remedies. It is different with the fruit fly. This is owing to the nature of its attacking the fruit. Depositing their eggs, as they do, beneath the surface of the fruit, places them at once beyond the reach of sprays and fumes, and leaves only one course by which they can be checked, and this consists of carefully picking all fruit suspected of containing the maggots and destroying it by boiling or burning the fruit. There is scarcely any variety of fruit which this fly does not attack.

*Life History.*—The female fly lays her eggs in the fruit after piercing the fruit with her ovipositor; the eggs soon hatch, and the maggots grow very rapidly, eating their way to the core of the fruit, and when they have attained their full growth they leave the fruit and enter the soil to pupate. In warm weather they only remain in the pupa stage for about ten days, coming out as flies and immediately begin the work of destruction again. Its chief aim in life seems to be the destruction of every fruit that it meets with.

*Natural Enemies.*—Up to the present time the home of this fly has not been discovered, consequentially its true parasite is not known.

Some years ago our travelling entomologist, Mr. Geo. Compère, set out to investigate this important point, but the matter was not followed up. Since then his successor, Mr. L. J. Newman, has done good work in perfecting the fruit fly baits, which for a number of years had been used with indifferent success (*vide* Nos. 21 and 22, page 531).

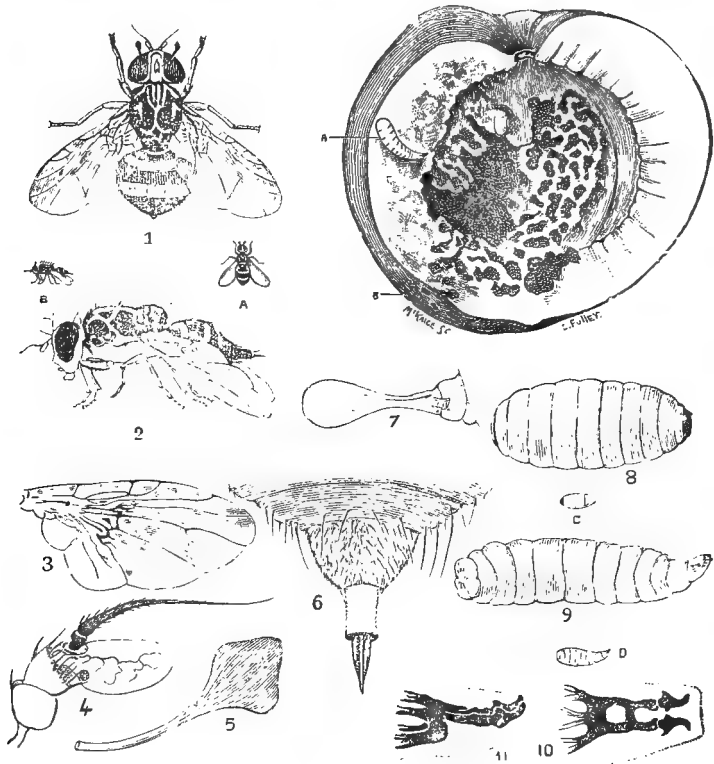

Fruit Fly (*Ceratitis capitata*).

**a**, maggot; **b**, holes where maggots have escaped; Fig. 1, male fly; **A**, same (natural size), viewed from above; Fig. 2, female fly, viewed from side; **B**, same, natural size; Fig. 3, wing of fly; 4, antenna; 5, clubbed appendage from head of male; 6 terminal segments of female's abdomen, showing the ovipositor; 7, halter; 8, pupa, or chrysalis; **c**, same, natural size; 9, larva, or maggot; **d**, same, natural size; 10 and 11, hooked mandibles of larvæ. (After Fuller).

#### FRUIT FLY OF THE TOMATOES (*Louchoea splendida*).

A dipterous insect, one and three-quarters lines long, of brilliant bronze-green colour, of stout guild, plump and stout. Froggart reports rearing it from tree-tomatoes, egg fruit (Brinjal); and potatoes as well.

## PLAGUE LOCUSTS.

*Plague Locusts.*—Every rural resident is, perhaps, familiar with the appearance of grasshoppers. But there are many kinds of these insects, representing at least two distinct families. The family *Acrididae*, or Locust, include those grasshoppers in which the antennæ are shorter than the body, and in which the ovipositor of the female is short, and made up of four separate plates. It is to these insects that the term locust is properly applied. The locusts of which we read in the Bible, and in other books published in olden times in Europe, are members of this family. It is unfortunate that there are some writers who apply the term locust to the cicada, an insect which belongs to another order, and not to the locust.

The term "plague locust" has been applied to many species of locust, both in this and other countries. This would lead some to believe that there is only one species which becomes a plague, where, as a matter of fact, there has from time to time, both in Australia and other countries, been many species which have become so numerous that they are plagues of the worst type, from a farmer's standpoint.

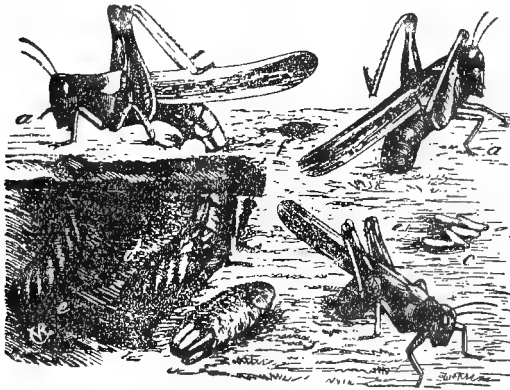

Female Locust in the act of laying eggs. (After Riley.)

In this State there are several species of locusts which cause some damage to both crops and pasture, but the one which the term "plague" has been applied to is *Pachytalis Australis*, Br.

However, it makes very little difference to the average farmer what species it is

that damages his crops; what the farmer wants to know is how best to handle them and prevent the destruction of his crop. To accomplish this, many experiments have been carried out in various countries.

Locusts lay their eggs in oval masses, and cover them with a tough substance. Some species lay their eggs in the ground, generally a bare spot. The female makes a hole in the ground with her ovipositor; and the operation is a very interesting one to watch. The female will press the tip of her abdomen into the soil, and at



the same time working the plates at the apex in such a manner that she will gradually bore a circular hole from one to one and a half inches in depth, according to species, and about a quarter of an inch in diameter. Some species will lay their eggs in old logs or stumps; then, after the eggs are laid (in clusters), the hole is covered up with a plug of gummy substance. There is but one generation a year, and in most cases the winter is passed in the egg state.

The most damage is caused by the grasshoppers while yet in the hopper stage, before maturity or winged stage.

The question of dealing with the locust swarms is a very perplexing one. Whenever locust swarms make their appearance it is generally found that they will extend over many thousand square miles of country at the same time; and all methods employed in their destruction up to the present time have only been partially successful. A few years ago it was expected that the application of the African locust fungus would successfully destroy these locust swarms, but this, too, has proved a failure. In the United States of America there are some sections where they use what are termed hopperdozers in locust-infested districts. These are made of iron or tin, in the form of flat trays, containing kerosene or tar, and are either pulled or pushed along against the wind, and the hoppers, in trying to get out of the way, will jump in or are blown in and killed, and millions are thus destroyed in a very short time. The poisoned bran mash has also proved a very successful remedy in reducing the number of hoppers. This consists in mixing 1lb. of arsenic, 2lbs. of sugar, 20lbs. of bran, 1lb. saltpetre, water added to make a mash. Mix the dry bran and arsenic in a tub; dissolve the sugar in sufficient water to make the mixture into a mash. A teaspoonful of the bait will kill locusts eating it a week after it has been laid out, but though its action is slow it is sure, and kills them in a few hours. The sugar is added to make the arsenic adhere to the flakes of bran.

A cheaper mixture or bait, called in Manitoba "Criddle mixture," after the name of its user, consists of 40 parts horse-dung; 2 parts salt, and 1lb. Paris green, and sufficient water to moisten it. Scattered over the infested places it is said to attract the insects for some distance, and is as efficacious several weeks after as it is when fresh. It offers this advantage besides that of cheapness, that farm stock won't pick it up as they would poisoned bran.

*Natural Enemies.*—It was expected some years ago to secure from New South Wales some of the tachina fly parasites which are to be found in that State; but owing to the dry condition of the country at the time no locusts were to be found. This parasite is itself, in turn, heavily parasitised by an ichneumon fly. There can be no doubt but that if we could introduce the tachina fly into this

State, and leave the ichneumon or secondary one behind, they would do more to check the locust swarms than all the artificial methods which we could apply. While in China, Geo. Compère found that

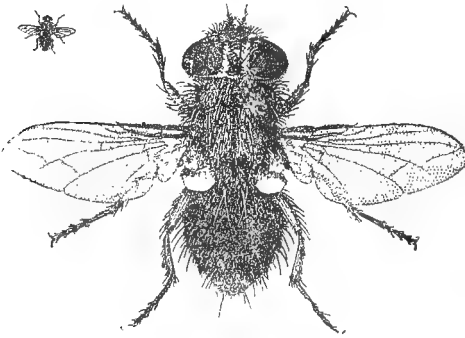

Tachina Fly (*Masicera pachytyli*, Sk.).  
 ♀, Parasite of Plague Locust in New South Wales. (Greatly enlarged.)  
 ♂, Same, natural size.

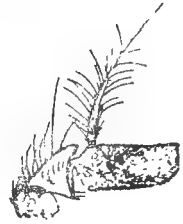

A 2  
 Antennæ of *Masicera pachytyli*.

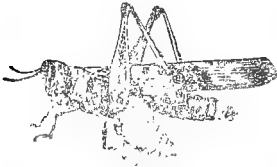

Parasite Maggot escaping from a  
 Locust.



Magnified and Life-sized }  
 Maggot of Locust Parasite.

there is a parasite in that country which destroys the eggs of the locust; and it is the egg parasite that will accomplish the most in holding these hoppers in subjection, as they destroy the locust before they have reproduced themselves.

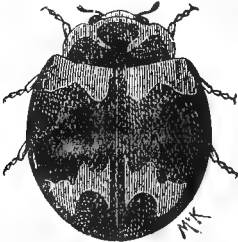

*Orcus Australis*, Boisd.

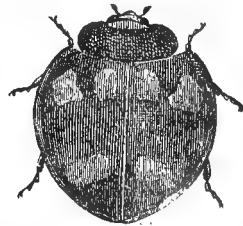

*Chilomenes quadripustulatus*, Muls.

#### USEFUL PREDACEOUS INSECTS.

While there are a great number of destructive insects in this State, there are also a large number of beneficial ones. In fact,

were it not for the beneficial forms, there would be very little, if any, vegetation left growing in this or any other Australian State, as there are thousands of indigenous species of insects which are held in complete subjection by other insects, and are unnoticed. It is only when an insect becomes a pest that any attention is given it, and it will be found that all pests are imported forms. It often happens that imported forms are subject to the attacks of indigenous forms, which accomplish a great deal in checking their spread, and the illustrations here shown, with one exception (*Leis conformis*), are indigenous species, and should be protected.

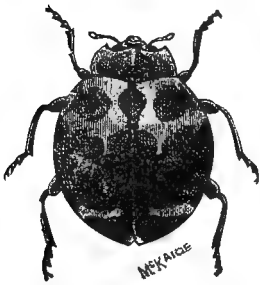

*Leis conformis*, Boisd.

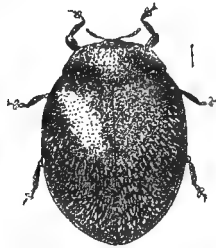

*Rhizobius debilis*, Blkb.

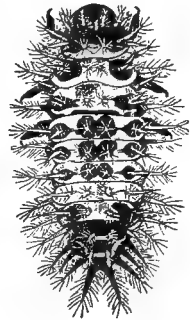

*Orcus Australasia* (larva).

These useful insects are themselves, in turn, attacked by parasites and predaceous ones, so that they do not accomplish as much in checking the spread of imported pests as they would otherwise do.

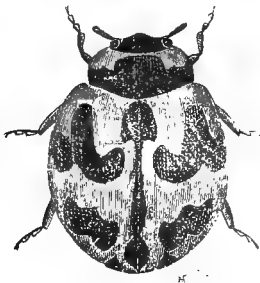

*Coccinella transversalis*, Fabr.

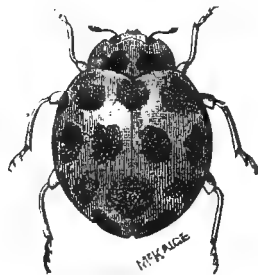

*Leis conformis* Boisd.

*Blastophaga grossorum*.—It has been well demonstrated that without the aid of these little insects we cannot successfully produce the Smyrna fig of commerce.

Anyone cutting open a fig when it has attained about one-third its size will see the flowers in full development, but unlike those of most fruit-trees, they make no outward appearance, but are concealed within the fig on its internal surface. They are male and female—the former situated near the orifice, the latter in that part of the concavity next the stalk—the flowers being concealed within the button-like fruit, consequently there is not the same opportunity for pollination to take place with the aid of bees, wind, or birds, as is the case with most other fruits, and nature, having left nothing

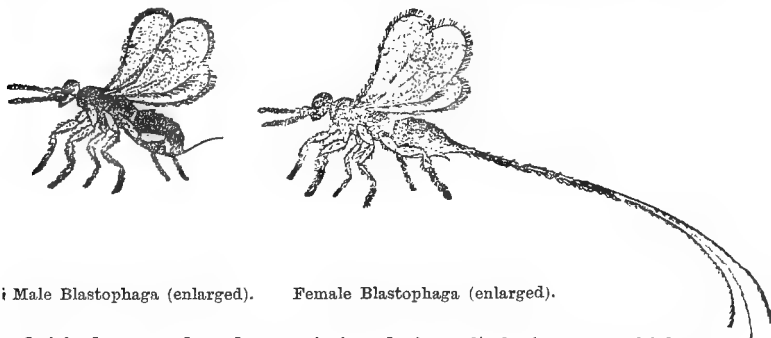

♂ Male Blastophaga (enlarged).

♀ Female Blastophaga (enlarged).

unfinished, created and commissioned these little insects, which are now known as Blastophagas, to perform the mission of caprification. The method by which this is accomplished is to plant the wild Capri fig amongst the cultivated ones: the insects infest the wild sort, which it leaves to visit the domestic one, entering to the interior of the fruit by the orifice. This is a very ancient practice. It was mentioned by the earliest Greek writers on natural history, and some state that it was first used in the Islands of the Archipelago. Some writers also doubt its utility; but the fact remains that the cultivation of the Smyrna fig has proven a failure without the presence of the Blastophaga.

## INDEX.

## A.

	PAGE
Alcohol—Absolute and Proof Spirit ... ..	433
Alluvium Soil ... ..	19
Almond ... ..	45
Almond, I.X.L. ... ..	297
"  Jordan ... ..	298
"  Lauder ... ..	299
"  Languedoc ... ..	297
"  Ne-Plus-Ultra ... ..	299
"  Nonpareil ... ..	297
"  Pruning of the ... ..	167
"  Sanderson's Seedling ... ..	299
Anthracnose or Black Spot on Grapes ... ..	564
Ants ... ..	574
Apples, Select, Ben Davis ... ..	229
"  "  Black Ben Davis ... ..	229
"  "  Chandler's Statesman ... ..	231
"  "  Cleopatra ... ..	229
"  "  Delicious ... ..	231
"  "  Dunn's Seedling ... ..	230
"  "  Ellison's Orange ... ..	229
"  "  Granny Smith ... ..	230
"  "  Irish Peach ... ..	229
"  "  Jonathan ... ..	229
"  "  King David ... ..	229
"  "  Marjorie Hay ... ..	229
"  "  Rome Beauty ... ..	230
"  "  Rokewood ... ..	231
"  "  Sturmer Pippin ... ..	231
"  "  Yates ... ..	232
"  Pear, Pruning ... ..	160
Apricot—Pruning of ... ..	169
Apricots, Select, Blenheim ... ..	238
"  "  Camden Pale Superb ... ..	237
"  "  Mansfield Seedling ... ..	238
"  "  Newcastle Early ... ..	237
"  "  Oullin's Early ... ..	237
"  "  Royal ... ..	237
Artesian Water ... ..	11
Ashes of Plants, Mineral Constituents of ... ..	189
Aspect modifies Climate ... ..	13
Avocado Pear ... ..	325

## B.

Bait ... ..	531
Banana and Plantain ... ..	325
Bark-bound Trees ... ..	158
Bearing of Trees, intermittent ... ..	158
Beneficial Insects— <i>Vide</i> Insects. ... ..	630

	PAGE
Blackberry ... ..	305
"    and Raspberry—Pruning of the ... ..	176
Blasting ground for Planting ... ..	32
<i>Blastophaga grossorum</i> ... ..	255, 632
Bordeaux-Mixture ... ..	525
Breadfruit—The ... ..	330
Budding ... ..	119
"    the vine ... ..	124
Bullock's Heart ... ..	331
Burning-off ... ..	33

## C.

Calendar for Spraying ... ..	520
Candying Citron and Lemon Peel ... ..	359
"    Fruit ... ..	362
Canning and Pulping ... ..	363
"    Household ... ..	365
"    Factory ... ..	366
Cape Gooseberry ... ..	306
Capri Fig ... ..	255
Carob Tree ... ..	45
Casks—Ullage in ... ..	462
Cherry—Pruning the ... ..	171
Cherries, Select, Bigarreau Napoleon ... ..	241
"    "    Bing ... ..	241
"    "    Black Bohemian ... ..	241
"    "    Black Eagle ... ..	241
"    "    Burgsdorf Seedling ... ..	241
"    "    St. Margaret ... ..	241
"    "    Suda ... ..	241
"    "    Werder's Early Black ... ..	241
Chestnut—The ... ..	299
"    and Walnut—Pruning of ... ..	172
Chocolate Soil ... ..	16
Cider—Vinegar from ... ..	500
"    and Perry ... ..	501
Citrus Fruits—Land suitable and unsuitable ... ..	247
Clearing ... ..	20
"    Specification for ... ..	28
Climate—Light ... ..	6
"    Rainfall and Water Supply ... ..	8
"    Temperature ... ..	5
"    Value of dry air ... ..	7
Coconut—The ... ..	332
Cold Storage of Fruit ... ..	396
"    "    How to cool and thaw ... ..	398
Coven, L. Lindley, and Agricultural Development ... ..	2
Cultivation—Catch crops in orchards ... ..	87
"    Cover crops or clean culture ... ..	88
"    Distance travelled when ploughing ... ..	82
"    Implements for ... ..	76
"    Mulching ... ..	88
"    Spider harness ... ..	81
"    Summer ... ..	74
Currant—The ... ..	306
Currants and Gooseberry—Pruning of the ... ..	177
Custard Apple or Cherimoyer ... ..	331

## D.

	PAGE
Date Palm—The ... ..	333
Drainage ... ..	39
" Arterial ... ..	40
" Deep ... ..	41
" Sand ... ..	44
" Sinkhole ... ..	41
" Surface ... ..	41
Disbudding ... ..	181
Diseases—Fungoid ... ..	547
Distillation—Making Piquette for ... ..	478
Dropping of Fruit—The ... ..	187
Drying Fruit ... ..	345
" Vegetables ... ..	358

## E.

Earth Nut or Pea-Nut ... ..	302
Explosives and Clearing ... ..	32

## F.

Fencing ... ..	51
" Diagram ... ..	52
" Gate ... ..	54
" Stretching Wire-netting ... ..	53
" Timber for ... ..	51
" Wire for ... ..	55
Fermentation ... ..	442
Fertilisers—Different sources of ... ..	193
" Effect of, on Fruit Crops ... ..	207
" Experiment for yourself ... ..	210
" Relation between Nitrogen and Ammonia ... ..	196
" Sulphate of Ammonia and Nitrate of Soda ... ..	196
" Nitrogenous ... ..	194
" Phosphatic ... ..	196
" Potassic ... ..	199
" Value of ... ..	205
" When and How to manure ... ..	208
Fertilising Matter removed by Fruits ... ..	190
Fig—Pruning the ... ..	173
Fig Tree—The ... ..	47
Figs ... ..	254
" Adam ... ..	258
" Adriatic ... ..	257
" Bourjassotte Black ... ..	258
" Brown Turkey ... ..	258
" Capri or Wild ... ..	255
" Caprification ... ..	255
" for Stock ... ..	258
" Smyrna ... ..	256
" White Genoa ... ..	257
" Stubberfield's Extra Early ... ..	257
Filbert and Cob ... ..	302
" Pruning the ... ..	172
Fruitfulness of Spurs and Wood ... ..	158
Fruit Candyng ... ..	359





	PAGE
Fungus Canker of the Apple ... ..	551
" Chlorosis ... ..	557
" Collar Rot on Citrus trees ... ..	561
" Crinkle or Pig Face ... ..	552
" Crown Gall of the Grape ... ..	571
" Curl Leaf ... ..	557
" Downy Mildew of the Grape ... ..	567
" Gumming, Collar Rot ... ..	557
" Die Back Mal-di-Goma, Sour Sap ... ..	561
" Leaf Rust ... ..	558
" " " of the Tomato ... ..	572
" Leaf Scald ... ..	559
" Loquat Black Spot ... ..	556
" Melanose ... ..	561
" Mouldy Core ... ..	552
" " " Root of Vines ... ..	565
" Moss and Lichens ... ..	552
" Oidium of the Vine ... ..	567
" Peach Freckle ... ..	559
" Pear Blight or Fire Blight ... ..	554
" Powdery Mildew ... ..	554
" " " on the Grape ... ..	567
" Ripe Rot of the Tomato ... ..	572
" Root Knot ... ..	560
" Rotting of Citrus Fruit ... ..	564
" Shot hole Disease ... ..	560
" Sooty Mould or Black Smut ... ..	562
" Squirt Berry of the Grape ... ..	571
" Strawberry Leaf Blight or Sunburn ... ..	564
" Tomato Wilt ... ..	573
" " " Blossom end Rot ... ..	572
" Twig Blight ... ..	552
" Water Core ... ..	554

## G.

Gate for Fence ... ..	54
Gathering and Marketing Fruit ... ..	370
Geropiga ... ..	478
Gooseberries ... ..	307
Grafting ... ..	89
" Affinity of Stock and Scion ... ..	95
" After care of ... ..	118
" Fruit trees Stocks ... ..	97
" Grape Vine Stocks ... ..	101
" Tools and Materials ... ..	91
" Wax and other coverings ... ..	94
" Ways of ... ..	102
Grape Fruit or Pomelo ... ..	252
" Directions for eating ... ..	252
" Juice, Unfermented ... ..	496
" " why it ferments ... ..	496
" Skins into manure ... ..	479
" Vine—The ... ..	259
" Vines—Infertile ... ..	508
" " Phylloxera Resistant ... ..	279
" " " Standard of Resistance ... ..	281
" " Riparia ... ..	385

	PAGE
Grape Vines—Riparia, Glory of Montpellier ... ..	285
"    "    "    Glabre Giant ... ..	286
"    "    "    Rupestris ... ..	282
"    "    "    Martin ... ..	284
"    "    "    Mission ... ..	285
"    "    "    Monticola ... ..	284
"    "    "    Solonis ... ..	287
"    "    "    Vitis Berlandieri ... ..	286
Grapes, Conveyor ... ..	417
"    for Drying ... ..	259
"    "    Currant, Zante ... ..	262
"    "    Corinth, White ... ..	260
"    "    Muscat of Alexandria ... ..	259
"    "    "    Gordo Blanco ... ..	260
"    "    "    Seedless Muscat ... ..	260
"    "    "    Sultana ... ..	261
"    Export ... ..	263
"    "    Colman Gros ... ..	264
"    "    Cornichon, Purple ... ..	264
"    "    Flame Tokay ... ..	263
"    "    Malaga, Red and Black ... ..	263
"    "    Ohanes or Almeria ... ..	264
"    Packing of ... ..	390
"    should be stalked ... ..	435
"    for Table ... ..	266
"    "    Chasselas of Fontainebleau ... ..	266
"    "    Chasselas of Negrepoint ... ..	266
"    "    Chasselas Vibert ... ..	266
"    "    Cornichon Blanc ... ..	268
"    "    Dradillo ... ..	268
"    "    Early Madeleine ... ..	266
"    "    Grand Centennial ... ..	267
"    "    Greengage or Late Green ... ..	269
"    "    Grand Turk ... ..	269
"    "    Haenapop ... ..	268
"    "    Kichmish All Violet ... ..	268
"    "    Muscat, Red of Frontignan ... ..	267
"    "    "    Madresfield Court ... ..	267
"    "    Raisins des Dames ... ..	268
"    "    Red Prince ... ..	268
"    "    Rose of Peru ... ..	268
"    "    Wortley Hall ... ..	269
"    Wine (Red) ... ..	278
"    "    "    Beclan ... ..	278
"    "    "    Moudeuse ... ..	279
"    "    "    Touriga ... ..	279
"    "    "    ... ..	269
"    "    Red ... ..	269
"    "    Aramon ... ..	269
"    "    Aspiran ... ..	270
"    "    Cabernet Sauvignon ... ..	271
"    "    "    Gros ... ..	272
"    "    Carignane ... ..	271
"    "    Dolcetto ... ..	272
"    "    Grenache ... ..	273
"    "    Malbeck ... ..	273
"    "    Mataro ... ..	274
"    "    Merlot ... ..	274
"    "    Morrastel ... ..	275

	PAGE
Grapes for Wine Shiraz ... ..	275
" " (Red) Verdot ... ..	276
" White Wine ... ..	278
" " " Chasselas ... ..	276
" " " Clairette ... ..	276
" " " Doradillo ... ..	276
" " " Folle Blanche ... ..	276
" " " Gouais ... ..	276
" " " Marsanne ... ..	277
" " " Palomino ... ..	277
" " " Pedro Ximenes ... ..	277
" " " Pineau ... ..	277
" " " Riesling ... ..	277
" " " Roussanne ... ..	279
" " " Semillon ... ..	276
" " " Sercial ... ..	279
" " " Verdelho ... ..	279
" When to pick ... ..	424
Green Manuring ... ..	204
Guava—The ... ..	338

## I.

Insects—Beneficial ... ..	630
" Aphid Feeding Lady-birds ... ..	579
" Black Scale Parasites ... ..	611
" <i>Blastophaga Grossorum</i> ... ..	256, 632
" <i>Chilomenes Quadripustulatus</i> ... ..	630
" <i>Coccinella transversalis</i> ... ..	631
" Codlin Moth Parasites ... ..	596
" Lace Wing Fly ... ..	584
" <i>Leis Conformis</i> ... ..	631
" <i>Orcus Australasice</i> ... ..	630
" Parasites of Soft Brown Scale ... ..	612
" " San José Scale ... ..	615
" " Cut Worms ... ..	600
" " Woolly Aphid ... ..	581
" Potato Moth parasite ... ..	604
" Red Scale Parasites ... ..	616
" <i>Rhizobius debilis</i> ... ..	631
" Soldier Bug ... ..	585
" Syrphus Fly ... ..	583, 585
" Tachina Fly of Locusts ... ..	630
" Tachina of the Cockchafer ... ..	587
" Pests ... ..	574
" " Ants ... ..	574
" " Aphid ... ..	578
" " <i>Aspidiotus Rossi</i> ... ..	620
" " Beetle, Honey and Spring ... ..	588
" " Bark Lice ... ..	578
" " Black Aphid of the Peach ... ..	581
" " " Scale ... ..	610
" " Brown Grape Scale ... ..	608
" " " or Soft Scale ... ..	611
" " Cabbage Aphid ... ..	579
" " " Moth ... ..	584
" " Case Moth or Bag Moth ... ..	585
" " Cherry and Plum Aphid ... ..	582
" " Cherry and Pear Slug ... ..	602

		PAGE
Insect	Pests—Cockchafer	586
..	.. Codlin Moth	588
..	.. Cut-worms	599
..	.. Curculio	598
..	.. Eel Worms and Gall Worms	602
..	.. Fruit Fly	626
..	.. Gall Worms and Eel Worms	602
..	.. Greedy Scale	618
..	.. Hawk Moth	600
..	.. Leaf Miner	602
..	.. Mealy Bugs	622
..	.. Mussel Scale	619
..	.. Natural Checks	620
..	.. Natural enemies ( <i>see</i> Insects, Beneficial)	630
..	.. Orange Aphis	582
..	.. Orange Mealy Bug	623
..	.. <i>Parlatoria</i> Scale	620
..	.. Pear and Cherry Slug	602
..	.. „ Leaf Blister Mite	603
..	.. Plague Locust	628
..	.. Plum and Cherry Aphis	582
..	.. Potato Moth	604
..	.. Rhizococcus of the Pine	620
..	.. Red Mite	605
..	.. „ Scale	616
..	.. „ Spider	606
..	.. Rutherglen Bug	607
..	.. San Jose Scale	612
..	.. Scale Insects	607
..	.. Snails and Slugs	624
..	.. Strawberry Beetle	620
..	.. Thrips	624
..	.. White Ants	575
..	.. White Cottony Cushion Scale	621
..	.. Wire Worms	626
..	.. Woolly Aphis	580
Introduction	..	i
Irrigation,	Advantage of	212
..	Amount of Water required	223
..	Evils of	213
..	Factors which influence	216
..	Methods of	218
..	Root Management	210
..	Spread of water from deep furrows	220
..	Water for Irrigation	214
..	„ „ „	18
..	Water measurement	214
J.		
Jack Fruit—The	..	339
Jellies	..	369
K.		
Kaki or Persimmons	..	287
Kerosene Emulsion	..	528
Kumquat	..	251

## L.

	PAGE
Labels	74
Ladders—Orchard	374
Land—Burning-off	33
" Clearing and Ring-barking	20
" Fruit	3
" Geraldton District	25
" Great Southern	23
" How to clear	27
" Murray	23
" Northam	25
" Preparation for Planting	34
" South-West	22
" Toodyay	25
" York	24
Laying-out the Ground	56
" " Diagonal	58
" " Distances Apart	60
" " Quincunx	59
" " Septuple	59
" " Square	57
Lees and Tartar	466
Lemons—The	252
" Curing	392
" Eureka	253
" Lisbon	253
" Sicilian	253
" Villa Franca	252
Lime—The	254
Litchi—The	339
Longan—The	340
Loquat—The	47
" Pruning of the	173
Loquats, Select	236

## M.

Mandarins, Select—Beauty of Glen Retreat	251
" " Emperor	251
" " Packing of	385
" " Scarlet	250
" " Tangerine	250
Mango—The	340
Manure from Grape Skins	479
" How to, when Planting	72
Manures and Green Manuring	204
" " Manuring	187
Map of Orchard and Vineyard	74
Marketing—Gathering Fruit	370
Melons	323
" Gathering and Packing	324
Mulberry	47
Mulching	88
Must—Components of, Grape	421

## N.

Nectarines, Select, Dr. Chisholm	240
" " Goldmine	240
" " Victoria	240

	PAGE
Nursery Stock and Fumigation ... ..	540
„ Trees,—Examination of ... ..	70
Nuts ... ..	295
„ Almond ... ..	296
„ Chestnut ... ..	299
„ Earth Nut ... ..	300
„ Filbert and Cob ... ..	302
„ Walnut ... ..	303

## O.

Oidium of the Grape Vine ... ..	567
Olive Ascolano ... ..	294
„ Bouquetier ... ..	291
„ Correggiolo ... ..	291
„ Gordal ... ..	294
„ Herbequina ... ..	291
„ Manzanilla ... ..	294
„ Mission ... ..	294
„ Oil ... ..	291
„ Pendoulier ... ..	294
„ Picholine ... ..	294
„ Pickled ... ..	294
„ Pleureur ... ..	291
„ Pruning the ... ..	174
„ Sevillano ... ..	294
„ The ... ..	289
„ Verdale ... ..	291
Oranges—Packing of ... ..	385
„ Select, Australian Navel ... ..	248
„ „ Cheriton... ..	250
„ „ Jaffa ... ..	249
„ „ Queen ... ..	250
„ „ Seville or Bitter ... ..	249
„ „ Valencia Late ... ..	249
„ „ Washington Navel ... ..	248

## P.

Papaya—The ... ..	341
Passion Fruit ... ..	322
„ „ Packing ... ..	323
„ „ Vine—Pruning of ... ..	175
Peach and Nectarine—Pruning the ... ..	165
Peaches, Select, Alexander ... ..	238
„ „ Amsden ... ..	239
„ „ Brigg's Early Red May ... ..	239
„ „ Carman ... ..	239
„ „ Dunhelm ... ..	238
„ „ Early Rivers ... ..	239
„ „ Elberta ... ..	239
„ „ Flat China ... ..	238
„ „ Hale's Early ... ..	239
„ „ High's Early Canada ... ..	239
„ „ Muir ... ..	239
„ „ Pullar's Cling ... ..	239

	PAGE
Peaches, Select. Salwaoy ... ..	240
Peduncled Fruit Trees ... ..	226
Pear-Packing of ... ..	385
Pears, Select. Bartlett ... ..	233
"  "  Clapp's Favourite ... ..	232
"  "  Gansel's Bergamotte ... ..	233
"  "  Howell ... ..	233
"  "  Kieffer's Hybrid ... ..	233
"  "  L'Inconnue ... ..	234
"  "  P. Barry ... ..	234
"  "  Packham's Triumph ... ..	234
"  "  Vicar of Winkfield ... ..	234
"  "  Winter Nelis ... ..	235
"  "  trays ... ..	387
Persimmon—Pruning the ... ..	175
Persimmons or Kaki ... ..	287
"  "  Dai-Dai Maru ... ..	288
"  "  Hachiya ... ..	288
"  "  Hyakume ... ..	288
"  "  Tane-Nashi ... ..	288
"  "  Yemon ... ..	288
Pests, Insect ... ..	515
"  "  Natural checks ... ..	518
"  "  Garden and Orchard Crops—Table ... ..	519
"  "  Remedies ... ..	525
Pests—Insect and Fungoid ... ..	574
Pinching Shoots ... ..	181
Pineapple—The ... ..	342
Piquette for Distillation ... ..	478
Plant Breeding ... ..	225
"  "  Pollination ... ..	226
"  "  Food ... ..	188
"  "  available and total ... ..	193
"  "  removed by a grape crop ... ..	191
Planting ... ..	63
"  "  Board ... ..	69
"  "  Draw plan of orchard ... ..	74
"  "  How to manure when ... ..	72
"  "  "  tie a tree ... ..	73
"  "  Selecting trees ... ..	70
"  "  Trees ... ..	69
"  "  Vines ... ..	64
Plum—Myrobalan or Cherry ... ..	48
Plums—Japanese—	
"  "  Botan or Abundance ... ..	245
"  "  Burbank ... ..	246
"  "  Kelsey ... ..	246
"  "  Red June (Shiro Smomo) ... ..	245
"  "  Satsuma Blood ... ..	246
"  "  Shiro ... ..	246
"  "  Wickson ... ..	246
Plums and Prunes—Pruning of ... ..	167
Plums and Prunes, Select—	
"  "  Damson ... ..	242
"  "  Diamond ... ..	244
"  "  Magnum Bonum ... ..	244
"  "  Pond's Seedling ... ..	254
"  "  Prune d'Agen ... ..	243
"  "  Splendor ... ..	243

	PAGE
Pollination ... ..	226
Pome trees ... ..	228
Pomegranate ... ..	49
Pomelo—The (or grape fruit) ... ..	251
"  Directions for eating ... ..	252
Proof Spirit ... ..	432
"  "  and absolute alcohol ... ..	433
Pruning ... ..	126
"  Burning the cuttings ... ..	146
"  Cutting to a bud ... ..	129
"  Fruit trees ... ..	147
"  outfit ... ..	126
"  Root ... ..	158
"  Summer, and thinning of fruit ... ..	180
"  Vines ... ..	131
"  When best to prune ... ..	131
Pulping Fruit ... ..	367

## Q.

Quince—Pruning ... ..	165
Quinces, Select—Angers ... ..	235
"  "  Bourgeaut ... ..	235
"  "  Champion ... ..	235
"  "  Van Dieman ... ..	235

## R.

Rainfall and water supply ... ..	8
Raisins ( <i>see</i> Fruit Drying) ... ..	
"  Seedless ... ..	351
"  Prices ... ..	352
"  Home consumption ... ..	353
Raspberry ... ..	308
Renovating old trees ... ..	155

## S.

Saccharometer ... ..	426
"  Baume's Scale ... ..	427
"  Brix or Balling ... ..	428
"  Guyot ... ..	428
Salt, limit in water ... ..	18
"  patches ... ..	18
Shelter trees ... ..	44
Shoots and Buds—Control of growth ... ..	154
Snails and Slugs ... ..	624
Soil— ... ..	13
"  Alluvium ... ..	19
"  Amendments and improvers ... ..	201
"  and its constituents—Weight of ... ..	191
"  Chocolate ... ..	16
"  Ironstone gravel ... ..	14
"  Salt patches ... ..	18
"  Sandy ... ..	19
"  Swamps ... ..	20



	PAGE
Specific Gravity Scale ... ..	426
"  "  Table ... ..	430
Split Limbs ... ..	156
Spray—How and when to ... ..	537
Sprayers, Dust ... ..	534
Spraying Pumps ... ..	531
Stone Fruits ... ..	236
Strawberry—A few profitable ... ..	320
"  Botanical structure ... ..	311
"  Classification of the ... ..	310
"  Cultivation of the ... ..	317
"  Irrigation and drainage ... ..	319
"  Leaf Blight ... ..	319
"  Manuring ... ..	315
"  Marketing ... ..	319
"  Mulching ... ..	318
"  Points of a good ... ..	319
"  Propagation ... ..	314
"  Pruning of ... ..	313
"  Pruning the ... ..	179
"  Soil and Location ... ..	313
"  The ... ..	309
"  Transplanting ... ..	316
Sultana—Pruning of ... ..	141

## T.

Thermometer Scales ... ..	456
Thinning the Fruit ... ..	183
Tomato—Pruning the ... ..	180
Trellises ... ..	143
Tropical Fruits ... ..	324
"  "  Alligator or Avocado Pear ... ..	325
"  "  Banana and Plantain ... ..	325
"  "  Breadfruit ... ..	330
"  "  Bullock's Heart ... ..	331
"  "  Coconut—The ... ..	332
"  "  Custard Apple or Cherimoyer ... ..	331
"  "  Date Palm—The ... ..	333
"  "  Guava—The ... ..	338
"  "  Jack Fruit—The ... ..	339
"  "  Litchi—The ... ..	339
"  "  Longan—The ... ..	340
"  "  Mango—The ... ..	340
"  "  Pineapple—The ... ..	342
"  "  Papaya—The ... ..	341

## U.

Ullage in Casks ... ..	459
"  "  "  ... ..	462
Unfermented Grape-juice ... ..	496
Unit Value of Fertilisers ... ..	205

## V.

Vats—Brick and Cement ... ..	412
Vegetables—Drying ... ..	358

	PAGE
Vinegar, from Wine and from Cider ... ..	500
" " " " " " " " " " " " " " " " " "	505
Vines, Grape -Summer Pruning of ... ..	483

## W.

Walnut—The ... ..	303
Water—Amount of required ... ..	223
" " fit for Irrigation ... ..	214
" " Limit of Salt in ... ..	18
" " Measurement ... ..	214
" " Spread of, from deep furrows ... ..	220
" " Supply ... ..	8
Whitewash—Washington ... ..	55
Wine—Acetification ... ..	491
" " Acidity in Wine ... ..	429
" " Aeration ... ..	436
" " Bitterness ... ..	495
" " Bottling of ... ..	480
" " Brick and Cement Vats ... ..	412
" " Casks—Cracked staves ... ..	411
" " " " Flagging ... ..	410
" " " " gauging of... ..	404
" " " " Keeping in good order ... ..	411
" " " " size of ... ..	403
" " " " Slack ... ..	410
" " " " Sulphuring ... ..	410
" " " " To Clean ... ..	406
" " " " To Discolour ... ..	407
" " " " To Disinfect ... ..	407
" " " " To Season ... ..	405
" " Casks and Vats ... ..	402
" " " " Timber for ... ..	402
" " Caskey taste ... ..	485
" " Casse ... ..	492
" " Casse or break in the Colour ... ..	461
" " " " " " " " " " " " " " " " " "	492
" " Colour, Deficient ... ..	485
" " Crusher and Stemmer ... ..	415
" " Defects and Diseases of ... ..	484
" " Definition and Classification ... ..	468
" " Dull Coloured ... ..	485
" " Earthy taste ... ..	484
" " Fermentation ... ..	418
" " Fermenting shed ... ..	400
" " Ferments of ... ..	442
" " Fixing and Filtering ... ..	463
" " Flowers of ... ..	490
" " Formula for fortifying ... ..	433
" " Greenness ... ..	484
" " Harshness ... ..	484
" " Heated ... ..	485
" " How to taste ... ..	469
" " Liqueurous ... ..	457
" " Low Alcoholic strength ... ..	485
" " Making ... ..	400
" " Making, Fining and Filtering ... ..	463
" " " " Geropiga ... ..	478

	PAGE
Wine Making, Lees and Tartar	466
„ „ Paraffin for Pumps, Piping, Vats, etc.	462
„ „ Refrigerators	449
„ Manutic fermentation	493
„ Pasteuriser	486
„ Per ton of grapes	434
„ Presses	417
„ Pumps	461
„ Putrid, Decomposition	485
„ Racking of	459
„ Revival of fermentation	448
„ Ropiness	494
„ Separating Must from Skin	440
„ Stalky taste and Bitterness	485
„ Starting fermentation	446
„ Sulphites instead of S. fumes	442
„ Sulphiting for clearing Must	440
„ Sweet, Alcoholic strength of	434
„ Tasting and technical terms	471
„ Temperature and fermentation	447
„ Temperature control	451
„ „ „	455
„ Tourne and Pousse Diseases	693
„ Vatting	438
„ Yeasts of fermentation	443
„ Young, Rearing of	458









