

TJ

843

W74

Cornell University Library
TJ 843.W74

Pumping water for irrigation.



3 1924 003 631 789

man

DEPARTMENT OF THE INTERIOR

WATER-SUPPLY

AND

IRRIGATION PAPERS

OF THE

UNITED STATES GEOLOGICAL SURVEY

No. 1

PUMPING WATER FOR IRRIGATION.—WILSON

WASHINGTON
GOVERNMENT PRINTING OFFICE
1896



Cornell University Library

The original of this book is in
the Cornell University Library.

There are no known copyright restrictions in
the United States on the use of the text.

WATER-SUPPLY

AND

IRRIGATION PAPERS

OF THE

UNITED STATES GEOLOGICAL SURVEY

No. 1



WASHINGTON
GOVERNMENT PRINTING OFFICE
1896

UNITED STATES GEOLOGICAL SURVEY

CHARLES D. WALCOTT, DIRECTOR

PUMPING WATER FOR IRRIGATION

BY

HERBERT M. WILSON

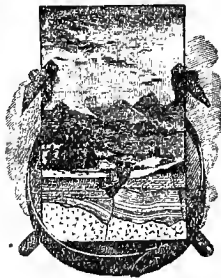

WASHINGTON
GOVERNMENT PRINTING OFFICE
1896

CONTENTS.

	Page.
Letter of transmittal.....	9
Preface.....	11
Introductory.....	15
Pumps and motive powers.....	17
Animal motive powers.....	20
Windmills.....	25
Water wheels.....	35
Hot-air and gasoline pumping engines.....	45
Steam pumping engines.....	46
Centrifugal and rotary pumps.....	50
Mechanical and siphon elevators.....	51
Storage reservoirs.....	54

ILLUSTRATIONS.

	Page.
PLATE I. Home-made wind engine, as used on the Great Plains.....	15
II. Steel windmill and tower carrying tank.....	30
III. Irrigating ditch and earth reservoir.....	32
IV. Windmills and circular reservoir.....	34
V. Midstream wheel driving a bucket pump.....	36
VI. Noria, or water wheel, lifting filled buckets.....	38
VII. Tympanum.....	40
VIII. Centrifugal pump driven by threshing engine.....	50
IX. Windmills and reservoir.....	54
FIG. 1. Raising water from well in India by paecottah.....	20
2. Series of shadoofs as used in Egypt.....	21
3. Swinging water by basket, or latha.....	22
4. Using the doon, or tilting trough.....	22
5. Bullocks lifting water by bag, or mot.....	23
6. Persian wheel driven by bullocks.....	24
7. Modern adaptation of Persian wheel.....	25
8. Double zigzag balance.....	26
9. Old type of windmill, mounted on central column.....	31
10. Early form of head of tower windmill.....	32
11. Undershot water wheel.....	37
12. Overshot water wheel.....	38
13. Turbine wheel driving centrifugal pump.....	40
14. Pelton water wheel.....	41
15. Wheel for lifting water on Chesapeake and Delaware Canal.....	42
16. Hydraulic ramming engine.....	44
17. General view and detail of siphon elevator.....	53

LETTER OF TRANSMITTAL.

DEPARTMENT OF THE INTERIOR,
UNITED STATES GEOLOGICAL SURVEY,
DIVISION OF HYDROGRAPHY,
Washington, July 9, 1896.

SIR: I have the honor to transmit herewith a paper entitled "Pumping water for irrigation," by Herbert M. Wilson, geographer, and to recommend that it be published as the first number of the series of papers "in relation to the gauging of streams and to the methods of utilizing the water resources," whose printing was authorized in the act making appropriations for sundry civil expenses of the Government for the fiscal year ending June 30, 1897, approved June 11, 1896.

Very respectfully,

F. H. NEWELL,
Hydrographer in Charge.

Hon. CHARLES D. WALCOTT,
Director United States Geological Survey.

PREFACE.

This paper by Mr. Wilson is the first of a proposed series of publications relating to water supply and irrigation. The object in view in undertaking a new series is to afford an opportunity for prompt publication of short reports, generally popular in character, relating to the water resources and the methods of utilizing these, with especial reference to the employment of water in agriculture. To reply to questions arising in various parts of the country regarding the progress of the investigation of the water resources and the facts relating to the available supply of water for irrigation, power, or domestic use, it is necessary to have pamphlets which can be sent out freely, and which, in order to answer the particular needs of individuals or communities, will not be too general in character. The series of bulletins issued by the Survey would serve as such means of communication were it not for the fact that by law these must be sold, and thus can not be used for official purposes or for placing the information acquired by investigation at once in the hands of the persons seeking to know the facts. By the law authorizing this new series it is possible for the Survey to distribute these papers to correspondents and to the numerous volunteer assistants who at one time or another have kindly aided by replying to letters of inquiry or schedules asking for specific data. Without such opportunities for distribution of small publications the officers of the Survey are placed in an embarrassing position, from the fact that they are compelled to ask favors in the way of statements and data of various kinds and are yet unable in general to more than thank the persons who have freely given their time to the preparation of letters and the filling out of blanks. Even when these persons have asked for a copy of the publication embodying the information which they have furnished, it has not been possible for a bulletin to be sent unless paid for by some member of the Survey.

Arrangements have been made for following this paper with others at short intervals treating of various subjects relating to the hydrography of the country and to details such as storing, pumping, and other processes of utilizing the waters. The following topics will probably be covered during the year: Measurements of Western streams; measurements of Eastern rivers; Northeastern water power; Southeastern water power; water supply of portions of Indiana and Ohio; artesian conditions of eastern Nebraska; underground water supply of

a portion of western Kansas; recent progress in artesian developments and irrigation in the Dakotas; artesian conditions of eastern Washington and portions of Idaho and Oregon; irrigation in the Salt River Valley of Arizona; methods of irrigation in California; seepage waters from irrigation; water storage in a portion of Wyoming; well waters of Nebraska; efficiency of windmills for irrigation; sewage irrigation, etc.

The data upon which these and other papers are based are being obtained largely through the field work of the Division of Hydrography, supplemented by correspondence carried on by means of schedules. Whenever practicable, arrangements are made with experts in various parts of the country to bring together the facts in their possession, rounding these out with additional investigation and preparing reports embodying this matter. Every effort is made, however, to preserve the distinctive character of an investigation and to push forward the work in directions where it is impossible for the individual to proceed unaided. It is not intended to bring together simply a lot of obvious facts and inferences relating to the water resources of the country, but to extend the bounds of knowledge in directions where exact information will have the greatest future value. It should be recognized that progress in new fields can never be so rapid as traveling over the old paths. It is only by bringing together clearly and concisely what is already known and building upon this that progress can be made in the utilization of the water resources of the country.

In the following paper by Mr. Wilson a general description is given of pumps and motive powers, and of windmills, water wheels, and various kinds of engines, noting the more important of these. The conditions surrounding the raising of water vary so widely that it is obviously impracticable to designate any one method as better than others, and a machine or device which to a man from one part of the country seems utterly useless may meet the requirements of some other locality. Mr. Wilson has therefore described, and in a few cases figured, devices which, while possessing no general applicability, yet contain suggestive features. It is not to be expected, for example, that in any part of the country human labor will be employed to any considerable extent in raising water, as is the case in Egypt, India, and other parts of the world; but the simplicity of the methods commend themselves, and a mention of these may serve to stimulate some inventive genius to make a practical application suitable for local needs. It is surprising to note how often the devices for raising water which in themselves are older than any written language have been reinvented and applied by the irrigators of the West. Again and again has the attention of the hydrographers of the Survey been called to the home-made devices for raising water based upon the principle of the Egyptian water wheel, or noria, or of the Persian bucket pump. These have

been devised by men who have considered the idea original with themselves, and could with difficulty be persuaded that their pet invention was old in the days of the Pharaohs.

In a new and rapidly developing country, such as the arid region, where methods of raising water for agriculture are constantly being modified and improved, it is desirable to have in mind all of the ways which have been found of value in the past. This pamphlet can by no means mention all or even a small part of these, being considered only as preliminary to more extended discussions. It is hoped that through the investigations of the Division of Hydrography a considerable body of accurate figures can be obtained concerning the methods and machinery for pumping large quantities of water now being put into operation. It may be interesting to note in this connection that as machinery is being modified to suit the requirements of lifting a large amount of water through a relatively small vertical distance, and at the least practicable expense, there is a tendency to return to the simple forms used by the primitive agriculturist, adapting these to modern machinery. For example, after trying all the complications of valves and pistons, of tight joints and complicated motions, designers of machinery are in some instances turning back to the old simple Persian wheel, which lifts water in buckets with the minimum of friction and of load to be raised.

F. H. N.

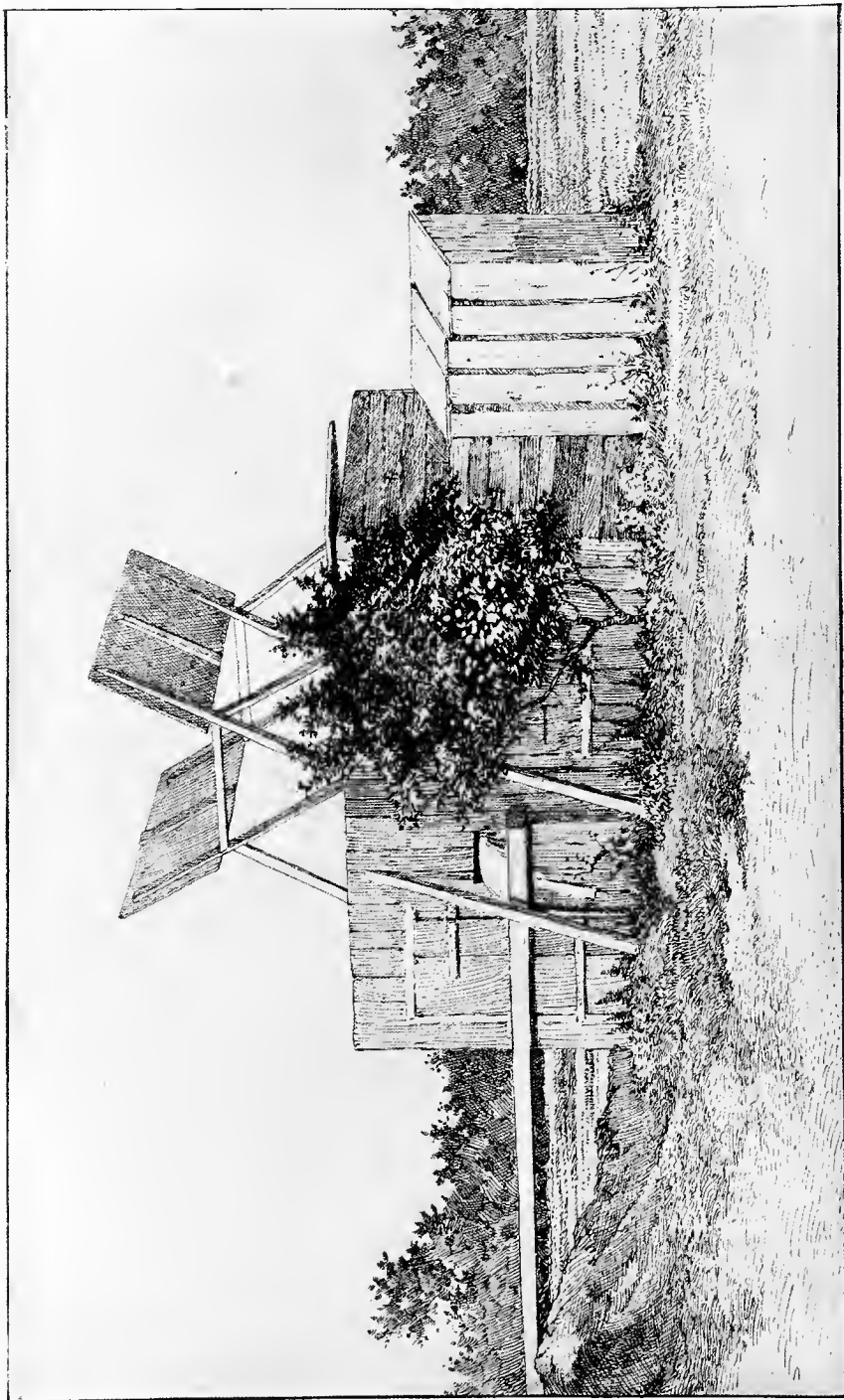

HOME-MADE WIND ENGINE, AS USED ON THE GREAT PLAINS.

PUMPING WATER FOR IRRIGATION.

BY HERBERT M. WILSON.

INTRODUCTORY.

Until within the last decade the water supplies used in irrigation in our Western States were brought to the places of utilization almost wholly by gravity. There are, however, large volumes of water situated at such low levels that gravity will not carry it to the fields, and only in recent years have we come to a realization of the fact that this water may be raised by pumps or other lifting devices to elevations from which it will flow by gravity to the irrigable lands.

Extensive areas may be brought under cultivation through pumping after the supplies which gravity alone will bring have been entirely utilized. Not only is the water which may be raised from wells or low-lying streams available, but that which finds its way by seepage from irrigation canals and irrigated lands may be gathered into wells and pumped to the surface and again employed in irrigation. For, as irrigation is practiced, the subsoil becomes saturated, the ground-water level is raised, and much of the water delivered to the surface by gravity systems finds its way by seepage from the fields into the soil and may through pumping be used again in irrigation, thus adding to the duties of the ultimate sources of water supply.

The value of pumping for such purposes has been recognized for ages in the older European and Asiatic countries, and a large portion of the irrigation in Europe, India, Egypt, China, and Japan is carried on by such means. In Oriental countries pumping is performed almost wholly by animal or man power. In some portions of Europe, notably in Italy, some pumping is done by modern machinery, chiefly in raising water from existing low-level to high-level canals. In our own country numerous pumping plants actuated by wind, gasoline, water, and steam powers have been erected within the last few years, and they have proved so efficient and economic as to at once gain favor with Western irrigators.

The real value of pumping as a means of irrigation, and the extent to which it may be employed, are as yet scarcely appreciated. A great many windmills and some water wheels are utilized in our Western

States for this purpose, and a little pumping is done by steam and gasoline. But the value of the water supplies to be derived from lifting is sure to increase greatly as the cheapness and adaptability of this method come to be fully recognized. It is now a well-established fact that pumping occasionally furnishes irrigation water more cheaply than does gravity, both as regards first cost of the pumping plant, equivalent to the cost of water rights, and as regards the cost of maintenance and operation, which corresponds to the annual water rental or rate in the gravity system. In pumping, the source of water supply is more directly under the control of the irrigator, while he is troubled by none of the vexatious controversies arising from questions of priority of right or of water appropriation, of time of supply, and of rotation in the ditches; nor is he so likely to have his supply cut down in seasons of drought.

According to the figures given by F. H. Newell in the report on Agriculture by Irrigation, prepared for the United States census of 1890, the average first cost of water derived from gravity supplies for the whole United States was \$8.15 per acre, varying between \$3.62, the average for Wyoming, and \$12.95, the average for California. The average annual water rental was \$1.07 per acre, ranging between 44 cents in Wyoming and \$1.60 in California. The average cost per second-foot of water on account of construction of some of the great gravity canals of the West, and based on the assumption that their whole supply was utilized, varied between \$125 for the Bear River Canal, Utah, and \$730 for the Turlock Canal, California. The cost per acre irrigated for the same works varied between \$5 for the Bear River Canal and \$14.50 for the Turlock Canal. The average cost per acre irrigated by some of the greater of the storage reservoirs of the West varied between \$19.96 for the Hemet Valley Reservoir in California and \$81.80 for the Sweet-water Reservoir in California.

On the other hand, numerous windmill pumping plants have been erected in the West, the first cost of which is equivalent to a charge of about \$20 per acre irrigated, or less, while the cost of maintenance, equivalent to annual water rental, is practically nil. Hydraulic rams have been utilized in pumping for irrigation at a cost of about \$10 per acre irrigated, with practically no charge for maintenance and operation. Gasoline pumping engines are extensively used in the West, the first cost of which has been equivalent to about \$30 per acre irrigated, with a cost of operation of \$1.25 per acre. Water-power pumping plants have been erected in the West at costs ranging from \$1 to \$15 per acre irrigated, and with operating charges varying between \$1 and \$2.50 per acre. Of steam pumping plants so far erected in the West the cost has ranged from \$5 to \$10 per acre irrigated, with an operating charge of from \$1.50 to \$3 and upward per annum per acre irrigated.

As an indication of the extent to which pumping, even in the crudest

forms, may be utilized, either to supplement gravity supplies or independently of them, it may be stated that in one small area in India, between the Ganges and Jumna canals, there are over 350,000 wells supplying water by lifting to 1,500,000 acres of crops. In Madras, India, 2,000,000 acres are irrigated by water pumped from 400,000 wells. In one small province in southern India there are over 100,000 wells, many of which have been sunk through hard rock to depths of from 80 to 90 feet and are capable of irrigating in ordinary seasons from 1 to 4 acres each. In our own country, on the great plains sloping eastward from the Rockies and on many of the broader intermontane valleys and in the great California valley, wherever the wind is comparatively constant and of relatively high velocity, vast areas of land may be brought under cultivation through irrigation by water lifted from wells by means of windmills. In like manner, streams which are flowing between steep banks may not only furnish water supplies for irrigation by means of pumping, through wind, steam, or gasoline power, but, if of sufficient size, may furnish water power for lifting. The extent to which water supplies are to be derived from such sources is yet difficult to estimate, but it is certainly within the realm of probability that eventually nearly one-half as much area may be brought under cultivation through lift as through gravity supplies.

PUMPS AND MOTIVE POWERS.

Pumps are machines for elevating water, and they may be divided into two principal parts: the pumping or water-elevating device, and the power by which this is operated. Pumps, as such, may be divided into four general classes, according to the principle on which they raise water, namely: (1) lift pumps, (2) force or plunger pumps, (3) rotary and centrifugal pumps; (4) mechanical or siphon elevators. The principle of lift and force pumping may be combined in one mechanism, and this may be either reciprocating or rotary, or it may be single or double acting.

The motive power may be derived from one of the six following sources, namely: animal, wind, water, hot air, explosive force of gas, and steam. Force, lift, and centrifugal pumps and mechanical elevators may be operated by almost any one of the various motive powers. Distinguished from these are three additional classes of pumping mechanisms, in which the motive power and the pump are inseparable. These are (1) injectors, vacuum pumps, and pulsometers, in which steam is the motive power; (2) hydraulic rams and hydraulic engines, in which water is the motive power; and (3) siphons and siphon elevators, in which atmospheric pressure is the motive power.

Lift pumps operate by drawing water through a suction pipe as the pump bucket ascends; as the bucket descends the water is forced through a valve in it, and is then lifted as it reascends. This variety of

pump is dependent for its operation on atmospheric pressure for the creation of a partial vacuum below the pump bucket.

Force pumps draw water through a suction pipe as do lift pumps, but to less heights, and the water is raised above the bucket by the action of a piston or plunger which forces it through a delivery valve. Force pumps may be single or double acting, and nearly all steam pumps are of the latter variety, the discharge of these being practically continuous, for as the water is drawn in at one end it is forced out at the other.

Centrifugal pumps depend for their action on a disk to which are attached propeller blades revolving inside a chamber. These propeller blades create a partial vacuum which lifts water, though but a few feet, into the chamber by suction, whence it is forced by the following propeller blade. Rotary pumps are practically revolving piston pumps, differing from the latter chiefly in that the propelling piece moves forward continuously.

Mechanical water elevators include not only the various patented devices by which water is raised by means of disks or buckets arranged on a revolving chain, but also the various ancient mechanisms employed in oriental lands for lifting water from wells. Among these are chain pumps, Archimedean screws, the tympanum, Persian wheel, noria, the latha or basket, the doon, the lat or paecottah of India, which is the shadoof of Egypt, the mot, and numerous other curious devices.

All the motive powers except wind may be used to operate any of the various classes of pumps. Ordinarily, however, animal power is used to operate the lighter forms of pumping machinery which are intended to elevate small quantities of water, and the common lift and force pumps and mechanical elevators of various kinds. Wind is employed almost exclusively for the operation of lift and force pumps, as it is too uncertain in its action to work well with ordinary centrifugal pumps or many forms of mechanical elevators.

The various motive powers may be divided into two general classes, according to the manner in which they are attached to the pumps. These are (1) direct-acting pumps; (2) fly-wheel and belting pumps.

Direct-acting pumps have, as a rule, no rotary motion, their action being reciprocating, both steam and water cylinders being mounted on a solid bed plate, so that the piston rod, which produces the power, has attached to it the plunger which elevates the water. Fly-wheel pumps may be direct-acting pumps or they may have the motive power at some distance from and independent of the elevating pump and be connected therewith through shafting or belting or some other mechanical device. The latter forms are usually not so satisfactory or reliable in their operation where used for irrigation, as they generally require more skilled attendance than do direct-acting pumps, though, on the other hand, their efficiency is often higher.

In the choice of pumping machines the irrigator should consider, among other things, the motive power which is most available and cheapest for his purposes, and the quantity and accessibility of his water

supply. Having gotten from these considerations an idea of the general form of pumping machine which will best suit his purposes, he will do well either to consult a mechanical or an irrigation engineer or, if the extent of his enterprise will not warrant this, to obtain advice from various makers of the form of pumping machine which he anticipates using. These persons will furnish him with details of cost and assist him to select the variety of machine best suited to his purpose, and he will thus be able to choose the most economic and efficient apparatus.

The pump and motive power which are to be employed in each particular case depend on the service to be performed and on various local modifying conditions. The variety of pump must be chosen according as greater or less volumes are to be elevated to greater or less heights. The motive power must be selected according to the pump chosen, the work to be done, and the fuel available, be this animal, air, water, gasoline, wood, or coal. Where means are limited and the area to be irrigated is small, the motive power chosen will usually be either animal or water. The first is cheapest of installation, but least economical, and the latter is next cheapest, providing a sufficient water supply is available for the operation of an ordinary mid-current undershot wheel, a noria, or a hydraulic ram. Where the area is small but the means at the disposal of the irrigator are less limited, animal power will usually be left out of consideration, and the choice will rest between wind, water, hot air, gasoline, and steam pumping engines. If the wind be reasonably steady and the facilities for the construction of a storage tank be good, wind motors, though not less expensive to install than some others, and not the most reliable, are least expensive and troublesome to maintain and operate. Where water is abundant, it furnishes, through water wheels, turbines, or water engines, the next least expensive power to maintain and operate, though not the cheapest to install. The class of water motor selected will depend wholly upon the fall and volume of motive power available and the height to which the water is to be raised. Hot-air and gasoline engines furnish the most reliable power for pumping water, and are less difficult to operate than steam engines. Gasoline engines are especially economical where coal or wood are expensive, though hot-air engines have a wide adaptability in the variety of fuel which they may utilize. Steam engines, where coal is cheap, furnish the most satisfactory motive power, but are generally not so economical to operate, especially where small areas are to be irrigated. For the pumping of large volumes, water and steam are the only competing motive powers.

The irrigator who proposes installing a pumping plant should consider all the various circumstances which affect the case under consideration. He should carefully weigh the necessity of having a permanent and steady supply, the inaccessibility of the plant for repairs or replacement of broken parts, the relative cost and accessibility of different kinds of fuel or of water, and the degree of intelligence and skill possessed by those who are to operate the machine employed.

ANIMAL MOTIVE POWERS.

Among the oldest and best known of these is the common domestic well sweep, which is the paecottah of India (fig. 1) and the shadoof of Egypt. In India this is operated by from one to two men who labor from six to eight hours daily and by its use raise from 1,000 to 3,000



FIG. 1.—Raising water from well in India by paecottah.

cubic feet per day. This apparatus is usually employed for but small lifts of from 5 to 12 feet, though under the name of shadoof in Egypt it is commonly employed for much greater lifts by using a series of several sweeps arranged one above the other, as illustrated in fig. 2. By

the latter means three men will irrigate from 2 to 4 acres a season. The average cost of irrigation by this means has been estimated in central India to be about \$5 per acre irrigated. The paecottah consists essentially of a leathern or earthen bucket hung from the light end of a pole which is pivoted near its farther extremity and oscillates in a vertical plane, the short end of the pole being counterbalanced by a weight, so that the bucket when full requires but little force to raise it. The man working this contrivance stands on the edge of the well and uses his weight to depress the bucket into the water, whence it is raised largely by the force of the counterweight and the water is delivered into a small ditch which leads it to the irrigable fields.

Others of the mechanical devices employed in India for utilizing man power to lift water are the latha, or basket (fig. 3), and the doon (fig. 4).

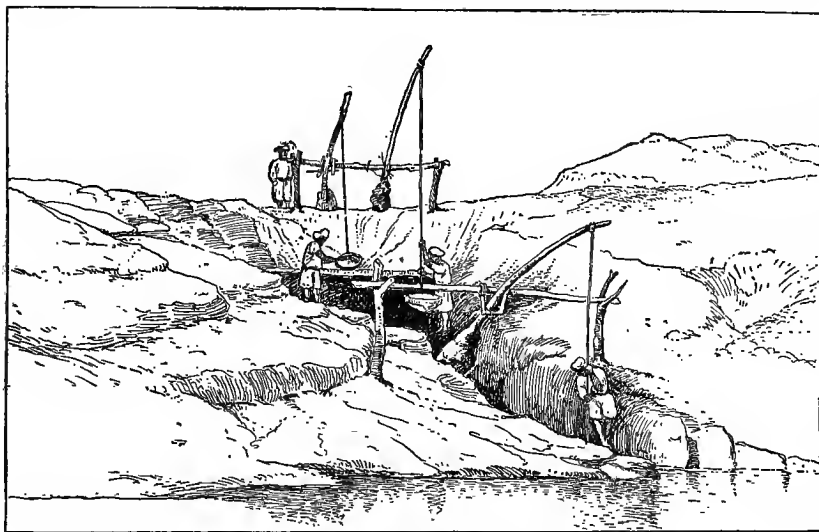

FIG. 2.—Series of shadoofs as used in Egypt.

The former is used for very small lifts of from 2 to 4 feet, and is operated by swinging the basket backward and forward in such manner that in swinging in one direction it dips into the water and is filled, and on its return to the farther end of its oscillation it is skillfully twisted so as to throw the water into a ditch. This apparatus is always operated by two men and is estimated to be capable of lifting 20,000 cubic feet of water 1 foot in height in ten hours, and the cost of its operation in India is estimated to average \$3 per acre irrigated, though this figure is doubtless too low. The doon is likewise used for very small lifts, and consists of an oscillating trough¹ pivoted near its center, so that one end is alternately pressed into the water and raised above the level of delivery, the water flowing from the other end into the ditch. The

¹Irrigation Works in India and Egypt, by Robert Burton Buckley, 1893, 348 pp.

weight of the water is partly balanced by a counterpoise, so that the man who stands over the water on the plank can depress the end of the doon into the stream by his foot, and then by stepping upon the

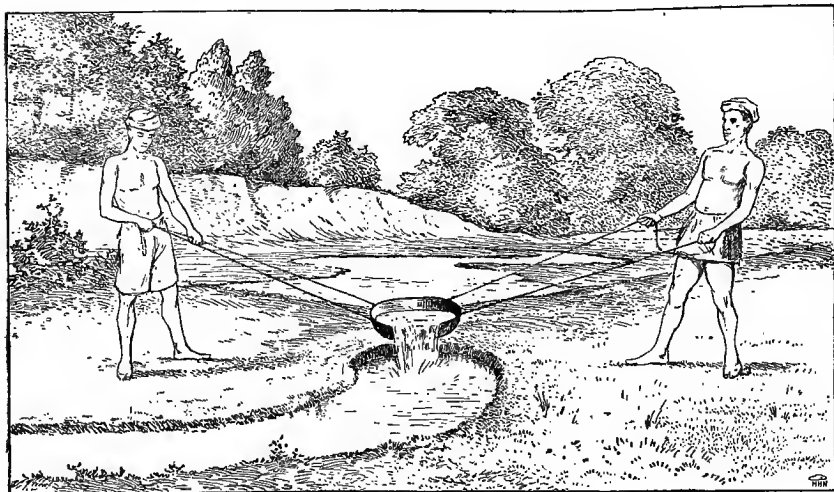

FIG. 3.—Swinging water by basket, or latha.

plank he can, with a slight exertion, slope the trough to the point of delivery. This apparatus is quite efficient for trifling lifts, and is estimated to irrigate 1 acre at an average cost of \$1.60, Indian wages.

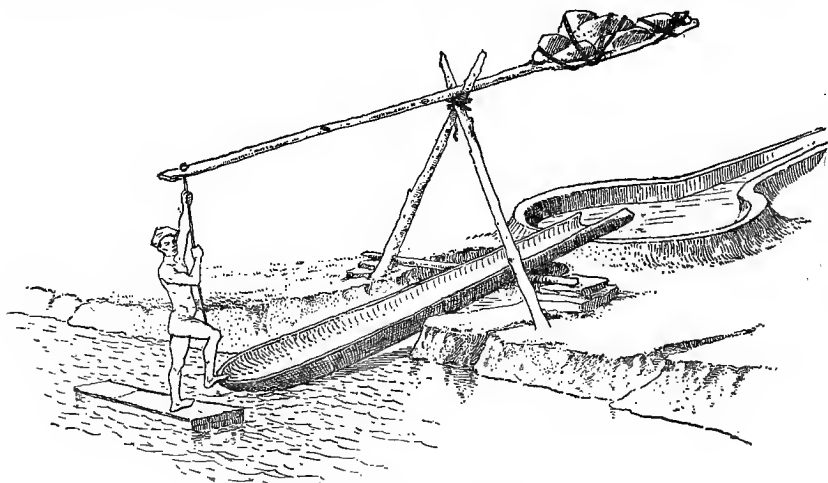

FIG. 4.—Using the doon, or tilting trough.

Of the mechanical devices used for lifting water by means of animal power, the more prominent are the mot and the Persian wheel. The mot (fig. 5) consists of a rope passing over a pulley and extending down into the well, and to the end of this is attached a bucket or other recep-

tacle. This is raised by two bullocks walking away with the rope down an incline, and thus drawing the bucket to the top of the well, where it is emptied into a distributing ditch. These animals are frequently so well trained that after reaching the bottom of their walk they return backward and at quite a rapid rate up the slope, while at other times they are trained to turn around and walk forward up the slope, again turning as they reach the top. The mot is frequently employed in lifting water from depths as great as 40 to 50 feet. It is operated by one or two men, according to the mode of construction of the water bag. In some cases this has to be emptied by one man standing at the well curb while another drives the bullock; in other cases the bag is emptied automatically by an ingenious attachment of the rope to an opening at its lower end, and one man only is employed, to drive the animals. With the mot it is estimated that two bullocks work-

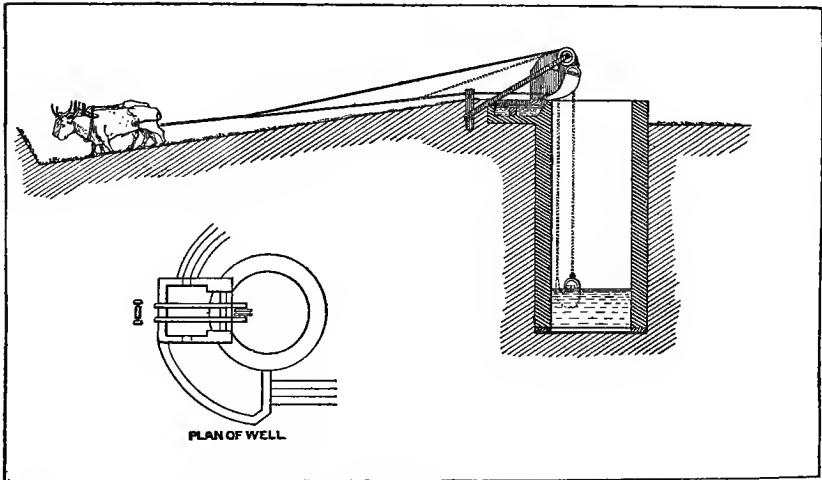

FIG. 5.—Bullocks lifting water by bag, or mot.

ing ten hours a day will irrigate $3\frac{3}{4}$ acres in a season of ninety days, and the average cost of irrigation by this means is \$3.50 per acre irrigated.

Perhaps the oldest, and certainly the most extensively used, of animal motive powers is the Persian wheel, which is employed commonly throughout India, Asia Minor, and Egypt. This consists of a vertical wheel (fig. 6) to the outer rim of which are attached buckets which dip into the well, or over its rim is hung a rope to which are attached the buckets, and these hang below the lower periphery of the wheel and dip into the well below. As the buckets reach the upper circumference of the wheel they spill their contents into a trough which leads the water through ditches to the irrigable fields. With the Persian wheel two bullocks will lift 2,000 cubic feet of water per day. This device is not uncommonly employed for lifts as high as 25 to 100 feet.

Recently there have been patented in this country a number of adaptations of the Persian wheel, skillfully designed and constructed in such manner as to be more efficient than the ancient oriental device. One of these consists of large metal buckets hung on heavy linked chains which revolve over the vertical wheel and dip into the source of water supply beneath. This wheel is operated by iron-cogged gearing, turned by sweeps to which one or more draft animals are attached (fig. 7). These wheels have capacities varying from 500 cubic feet per hour for one horse to 2,000 cubic feet per hour for four horses for a depth of 20 feet, and their first cost ranges between \$200 and \$500. There are also on the market in this country a number of mechanical devices for utilizing animal power in pumping, consisting of various forms of sweeps to be operated by horses walking in a circle or by treadmills for utilizing horse, bullock, or sheep power through gearing and shafting. Most of

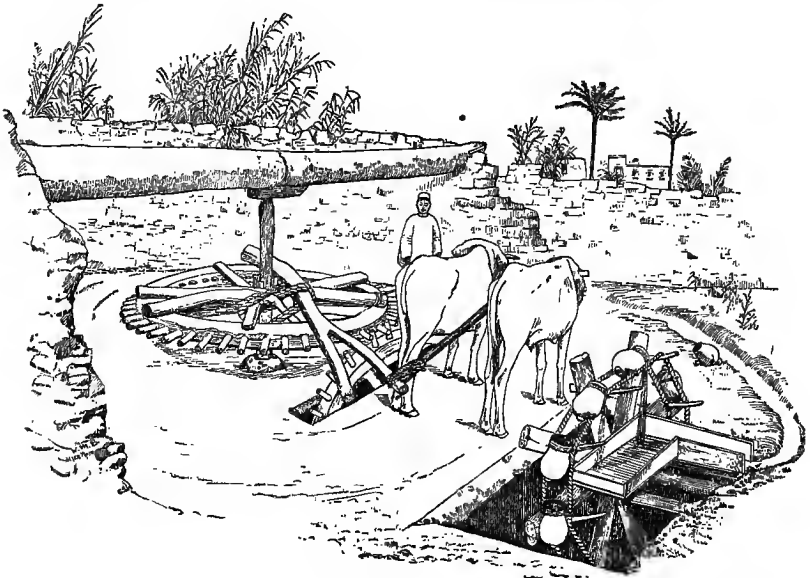

FIG. 6.—Persian wheel driven by bullocks.

these are simple in construction and operation and are not liable to get out of order. They furnish motive power usually for lifting water by means of mechanical elevators or force or centrifugal pumps, and are, with their pumps, capable of lifting sufficient water with a two-horse device to irrigate from 2 to 5 acres per season, while this amount could be at least doubled if a storage tank of sufficient capacity were provided for retaining water during periods when not wanted for immediate use.

An ingenious device for lifting water by man power is the double zigzag balance of Asia Minor and Egypt. This contrivance (fig. 8) consists of a double series of wooden troughs or gutters, the extremities of which are fastened and rise one above the other at an acute

angle. At the junction of each pair of troughs are placed wooden valves to prevent the return of water. This balance is suspended at its upper end on a level with the irrigating ditch, and is caused to oscillate about this as a center, much as does a pendulum, the motion being produced by a couple of men pulling on ropes. The lower ends of the troughs dip into the stream from which the water is to be lifted, and at every oscillation each series of troughs empties its water into that immediately above, until it is finally lifted to the summit of the balance, whence it is discharged into the irrigating ditch.

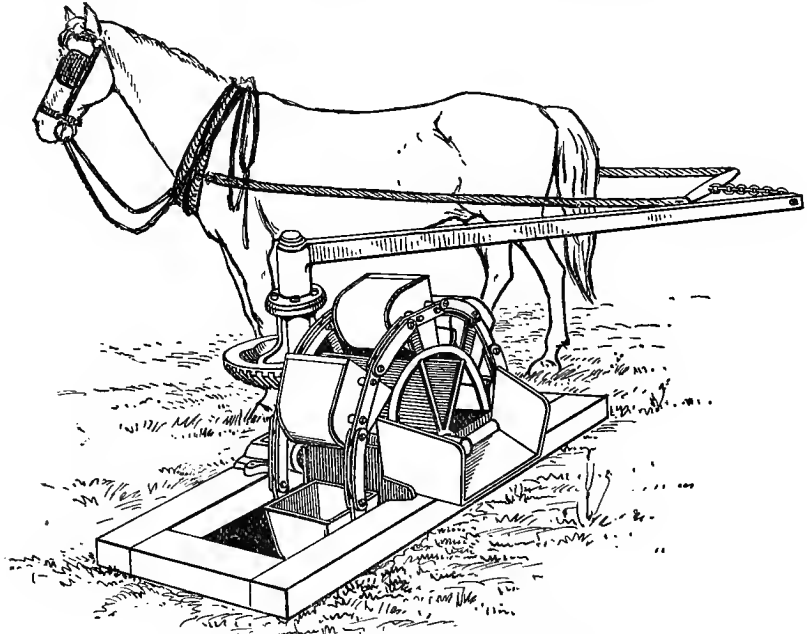

FIG. 7.—Modern adaptation of Persian wheel.

WINDMILLS.

Irrigating water is now being extensively pumped by windmills in various portions of the West, notably in the San Joaquin Valley of California, in Kansas, Nebraska, and the Dakotas, and elsewhere on the Great Plains east of the Rocky Mountains. Until recently windmills have been most extensively employed for pumping water for domestic use, but as water supplies for irrigation have become scarcer, and as practical farmers have come to appreciate the value of irrigation, they have in seeking new water supplies resorted quite extensively to windmills as motive powers for pumping water. The chief objection to windmills for this purpose is that they are dependent upon the force and regularity of wind for their operation, and as a result they do not furnish as steady and reliable a power as do water, steam, and other agents. This objection is, however, not serious on the Great Plains between the Rocky Mountains and the Mississippi River, especially if

storage reservoirs are employed as an adjunct to the mills, for in that region there is, throughout most seasons, a sufficiently steady and powerful wind to keep the wind wheels constantly turning. In other portions of the West the winds are less certain in their action, and may fail the farmer at the very time when he is most in need of a water supply.

Windmills are too frequently employed to pump water for irrigation

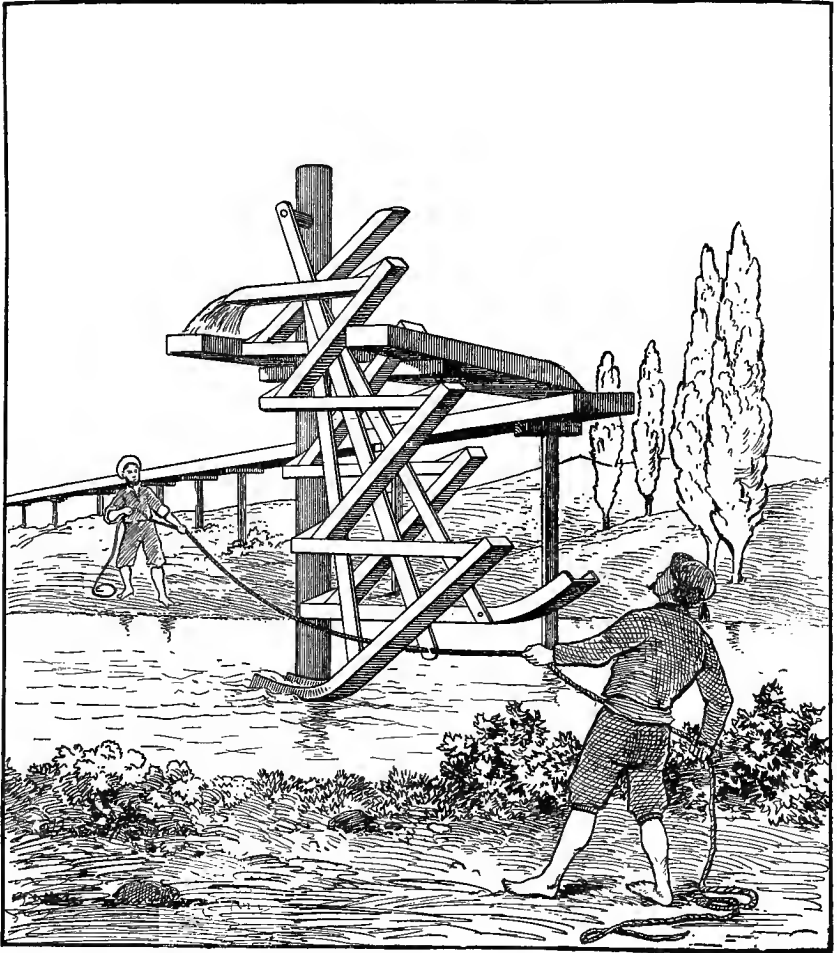

FIG. 8.—Double zigzag balance.

either from the uncertain supplies derived from drive wells or without the aid of a storage tank or reservoir in which to retain the surplus pumped at such times as it is not utilized in irrigation. As a result the supplies which they furnish are insufficient and unsteady, and this has led to their condemnation. The fault in such cases has not been with

the mill but with the user. In order to obtain good results from windmills they should not be used where the wind is uncertain and shifting, or in connection with a poor pump, or where a water supply equal to their full pumping capacity is not available; and they should invariably be supplemented by an ample storage reservoir.

The wind may blow at any time during the twenty-four hours, and is no more likely to blow in the daytime than at night, when water is not used in irrigating the fields. It is also likely to be as active at seasons when irrigation is not in progress and during the late winter and spring months as when water is being run upon the fields. For security, therefore, and in order to irrigate a reasonable area from a pump of given capacity, ample storage room should be provided for the water which can be pumped during several weeks. This storage room may be obtained by using one of the various forms of elevated wooden tanks supplied by windmill makers; or, better, if the windmill can be located at a high point on the farm an artificial reservoir may be constructed of earth at this point and be suitably lined with earth puddle or asphaltum. It should, if possible, be sheltered from the sun by a roof, so as to decrease losses by evaporation. Such a storage reservoir can easily be given sufficient capacity to retain a much larger volume of water than can economically be stored in a wooden tank.

The amount of work which a windmill will perform depends on the force and steadiness of the wind, the size of the wind wheel, its design and construction, and its location. An average wind velocity of not less than 6 miles per hour is required to drive a windmill, and, on an average, winds exceeding this velocity are to be had during eight hours per day; hence, about two-thirds of the total wind movement is available for work. According to reports of the United States Weather Bureau, the average wind movement of the entire country is about 6,000 miles per month, or over 8 miles per hour. These averages are somewhat exceeded in Dakota, where the hourly velocity is from 10 to 12 miles, as it is in Nebraska, Kansas, and neighboring States, while they are too great for some other portions of the arid West. The following table gives roughly the force of the wind for ordinary velocities:

TABLE I.—*Wind velocity and power.*

Miles per hour.	Velocity in feet per second.	Pressure per square foot, in pounds.	Miles per hour.	Velocity in feet per second.	Pressure per square foot, in pounds.
6	8.8	.1	30	44.0	4.4
10	14.7	.5	35	51.3	6.0
15	22.0	1.1	40	58.7	7.9
20	29.3	2.0	45	66.0	10.0
25	36.7	3.1	50	73.3	12.3

Table II, which is derived from Mr. A. R. Wolff's treatise on the windmill,¹ and is based on scattered data of actual performances, shows the capacity of a windmill having various diameters of wheels with an assumed average velocity of wind of 16 miles per hour and working eight hours per day.

TABLE II.—Capacity of windmill.

Size of wheel, in feet.	Revolutions of wheel.	Gallons of water raised per minute to an elevation of—						Horse-power developed.
		25 feet.	50 feet.	75 feet.	100 feet.	150 feet.	200 feet.	
10	60 to 65	19.2	9.6	6.6	4.7	-----	-----	0.12
12	55 to 60	33.9	17.9	11.8	8.5	5.7	-----	.21
14	50 to 55	45.1	22.6	15.3	11.2	7.8	5.0	.28
16	45 to 50	64.6	31.6	19.5	16.1	9.8	8.0	.41
18	40 to 45	97.7	52.2	32.5	24.4	17.5	12.2	.61
20	35 to 40	121.9	63.7	40.8	31.2	19.3	15.9	.78
25	30 to 35	212.4	107.0	71.6	49.7	37.3	26.7	1.34

According to Mr. Wolff's estimate, the cost of operating a windmill for a 25-foot lift, including interest on first cost and charges for maintenance, ranges from $\frac{3}{4}$ cent per hour for a 10-foot wheel to $2\frac{1}{2}$ cents for a 16-foot wheel and $4\frac{1}{4}$ cents for a 25-foot wheel. From an inspection of the foregoing, it is evident that the windmill is one of the most economical of motive powers. Its operation calls for no expense for fuel and little for attendance or repairs. In comparison with it the steam engine requires large expenditures for fuel, repairs, and attendance, and nearly all water motors call for heavy outlay in providing and maintaining their water supply as well as for repairs and attendance. It appears that on the average the economy of a windmill is at least one and one-half times that of a steam pump, while it has an additional economy over the latter because of the attendance and repairs demanded by the steam boiler.

Extensive experiments with a view to obtaining a comparison of the efficiency of various windmills have been recently made by Mr. J. A. Griffiths in Australia. The highest net efficiency observed in Mr. Griffiths's experiments with the wind blowing 7 miles per hour was 25 per cent. Table III gives the results of his experiments for the five American-made wind wheels tested.²

¹The Windmill as a Prime Mover, by Alfred R. Wolff, M. E., John Wiley & Sons, New York, 1890, 161 pp.

²Windmills for raising water, John Alfred Griffiths: Minutes of Proceedings of the Institution of Civil Engineers, Vol. CXIX, London, 1895, pp. 321-343.

TABLE III.—Capacities and efficiencies of several windmills.

	Stover solid hand-control rudder.	Perkins solid automatic rudder.	Althouse folding rudderies.	Carlyle automatic rudder.
Outer diameter of sail wheel.....feet..	11.5	16.0	14.2	9.8
Inner diameter of sail wheel.....do.	4.5	6.0	4.5	4.2
Gross area of sail wheel.....square feet..	104	201	157	80
Weather angle at outer ends of vanes.....degrees..	43	36	30	50
Diameter and stroke of pump.....inches..	3 by 4	3 by 10 $\frac{1}{4}$	3 by 10	3 by 4
Average head of water during tests.....feet..	29.2	39.0	66.3	30.7
At maximum efficiency:				
Velocity of wind per hour.....miles..	5.8	6.0	7.0	6.0
Velocity of mill per minute.....revolutions..	13	7.5	12.6	12.5
Actual horsepower.....	.011	.024	.065	.012
Horsepower per 100 square feet of gross area.....	.011	.012	.041	.015
Maximum net efficiency.....per cent..	8.7	8.9	19.3	10.4
In 100 average hours, calm locality:				
Average quantity of water lifted per hour.....gallons..	153	259	267	145
Average continuous horsepower developed per 100 square feet..	.022	.025	.057	.028
Average continuous gross horsepower developed.....	.023	.050	.089	.022
Average net efficiency.....per cent..	2.1	2.5	5.5	2.7
In 100 average hours, windy locality:				
Average quantity of water lifted per hour.....gallons..	287	525	540	270
Average continuous horsepower developed per 100 square feet..	.041	.051	.115	.057
Average continuous gross horsepower developed.....	.043	.102	.18	.046
Average net efficiency.....per cent..	.28	.71	1.59	.72

While designed on lines somewhat similar to those of a water wheel, a wind wheel differs from the latter in that it is wholly immersed in a sea of air, while the water wheel is acted upon by a limited current of water; therefore, while the common paddle wheels of an undershot water wheel develop considerable power, as one side only is immersed in the stream, no result can be obtained by using such a form of wind wheel unless one side of the wheel be screened from the air. This effect is obtained in a crude wheel used in some portions of the West, and known variously as the Wind Rustler, Jumbo, or Mogul windmill (illustrated on Pl. I). Such a contrivance is of course less efficient and less reliable than the regular form of windmill, because it is placed so near the ground that it does not receive the full force of the wind. Moreover, the directing of the mill to the wind is not under the control of the irrigator, and it will accordingly operate only when the wind is blowing in a direction nearly at right angles to its horizontal axis. Such a contrivance may serve as a makeshift for the pioneer who does not possess means with which to purchase a well-designed wind wheel, enabling him to bring under cultivation a trifling area of land, and to get a start in life. A number of Moguls are successfully employed in the West which have wheels of 14 to 18 feet diameter, 6 to 8 fans of about 2 or 3 by 10 to 15 feet, and are each capable of pumping sufficient water to irrigate 1 to 2 acres with a 25-foot lift. Such a contrivance costs from \$20 to \$100, or even more, according to the amount of hired labor employed in its construction.

The well-known forms of windmills consist of arms, cross bars, and clothing, and their vanes are made plane, warped, or concave. The older type of cloth or canvas-sail mill is common in Europe, especially in Holland, and has generally four arms. The narrow part of the sail is usually covered with a wind board, and the broader with wind slats of wood or with sailcloth. Modern American mills differ from the older European type in that they are chiefly of the propeller form, and instead of a small number of sails of considerable width are made with a great number of blades or slats of small width. They also differ in appearance from the European mill, as the wheel presents a closed surface as compared with the large open spaces between the arms of the European sail wheel. As a result of this mode of construction, the American mill is lighter in weight as well as in appearance than the European mill, and though the wide angle of the vane is not so advantageous as in the sail mill, the surface presented for a given diameter is sufficiently greater to more than compensate.

The direction of the wind is changeable, and, in order that the shaft on which the wheel revolves may be properly directed toward it, its support must be movable, so that it can revolve about a vertical axis. This revolution is effected in various manners in the old European mills, and, according to the method employed, they may be divided

¹ The Mechanics of Engineering and of Machinery, Weisbach and Du Bois, Vol. II, Hydraulics and Hydraulic Motors, John Wiley & Sons, 1889.

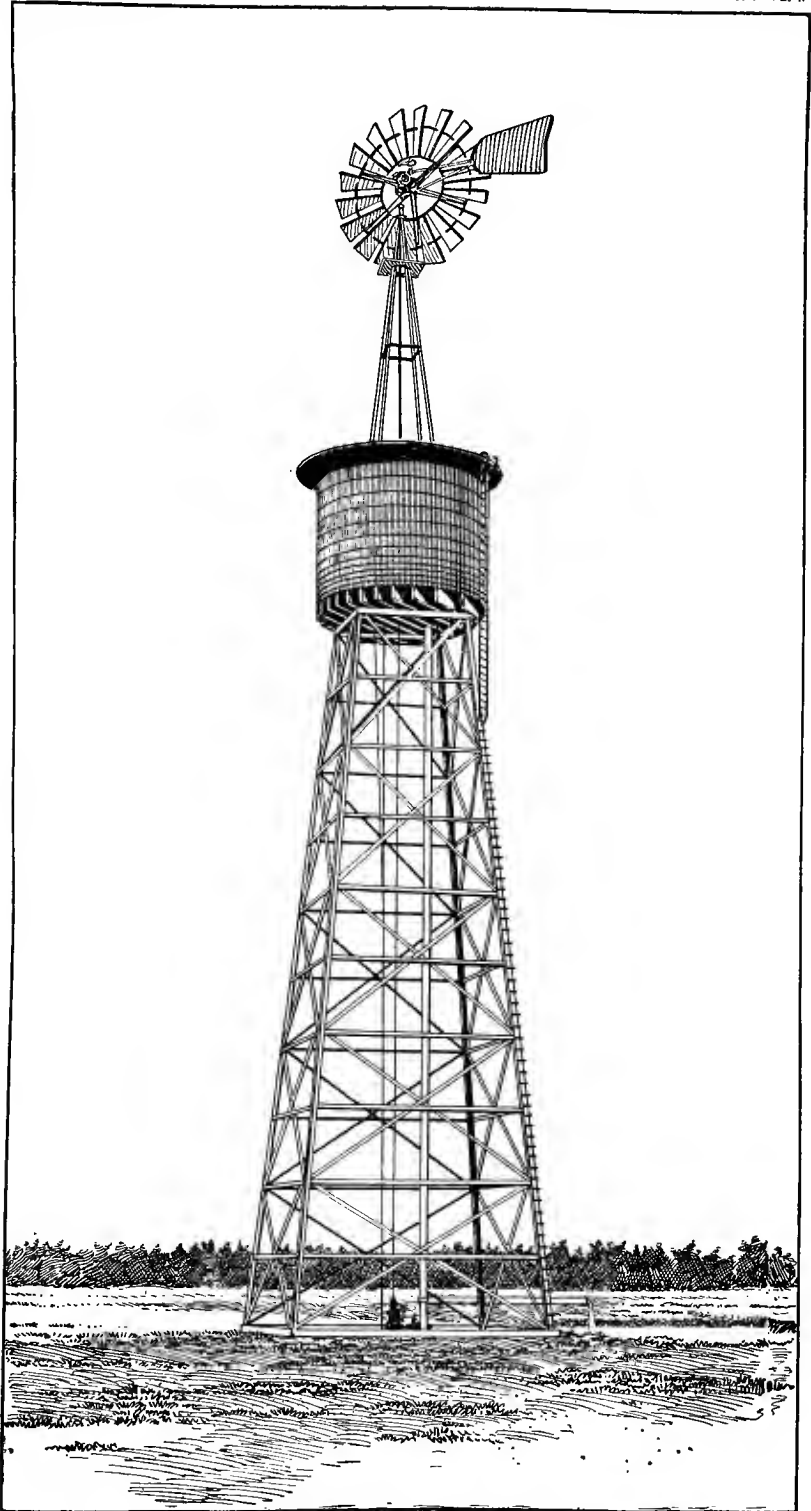

STEEL WINDMILL AND TOWER CARRYING TANK.

into three classes: the post mill of Germany, the tower mill of Holland, and a type midway between these two (fig. 9), being like a tower mill in which nearly the whole mill revolves, as in a post mill, not merely the upper portion alone, as in the tower mill proper. In the post mill the entire building, wheel and all, revolves about a central fixed column or post. In the tower mill the dome-shaped cap, which is

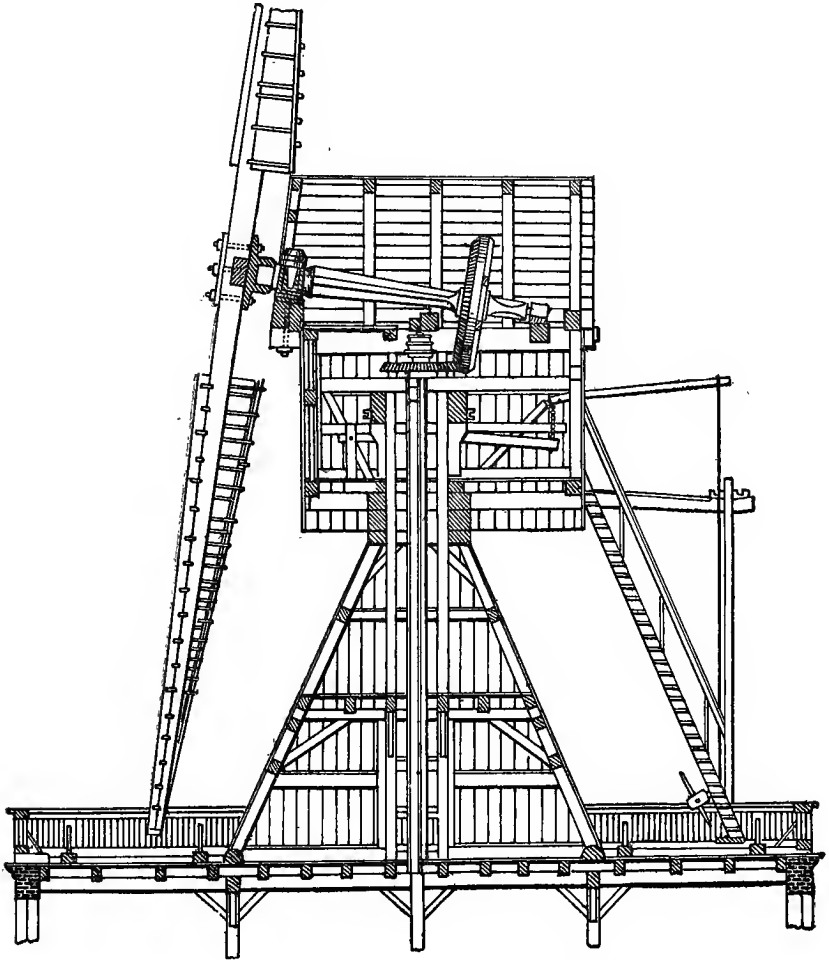
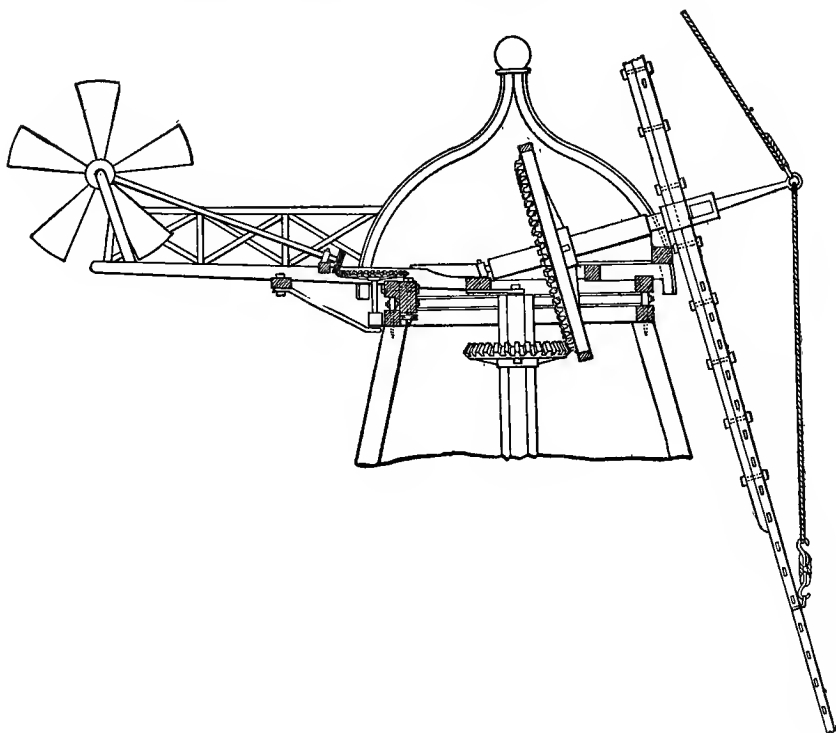

FIG. 9.—Old type of windmill, mounted on central column.

the only movable portion of the mill, rests on a stationary tower of wood or masonry. The wind shaft carrying the wheel is set at a slight inclination to the vertical. This shaft transfers its power by means of cogwheels to the vertical shaft which turns the mill and actuates the pump. The wheel is turned in the direction of the wind by means

of a lever or hand wheel or by means of a large vane or wind wheel (fig. 10) attached to a secondary axis.

The several types of American windmills are distinguished by the form of the wheel and the mode of regulating or governing its position and direction so as to obtain a uniform power and rate of revolution under varying wind velocities. These mills may be divided into two principal classes, namely: (1) sectional wheels with centrifugal governor and independent rudder, and (2) solid wheels with side-vane governor and independent rudder. In addition to these are a number



10.—Early form of head of tower windmill.

of special types, including various combinations of solid and sectional wheels and those having varying arrangements of rudder. Some of these special types are rudderless, the wind pressure upon the wheel being relied on to bring it into direction.

In selecting a windmill to perform a given duty the irrigator will have many forms from which to choose, and, after a careful perusal of catalogues and circulars furnished by different makers, must use his own discretion in choosing that which seems to best fit his requirements. Below are enumerated a number of the more prominent American windmills. No attempt is made to name them in the order of excellence.

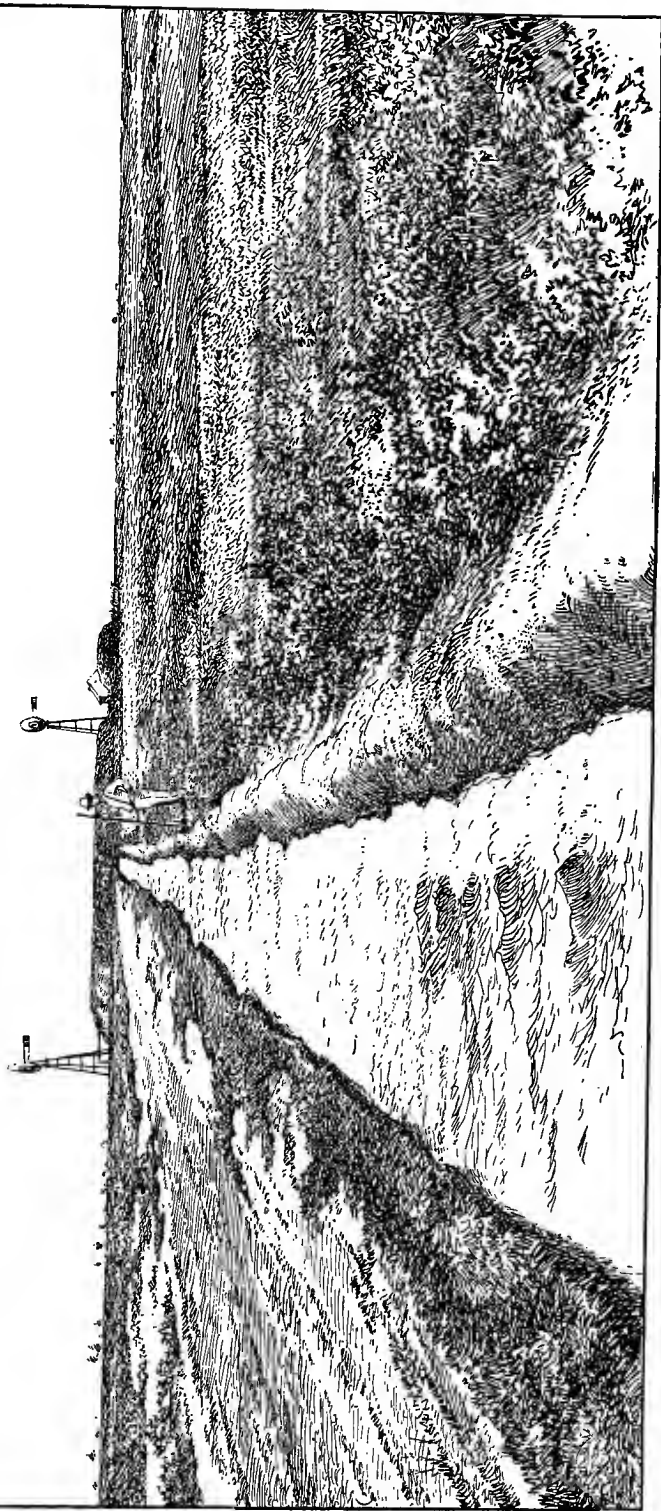

IRRIGATING DITCH AND EARTH RESERVOIR.

Moreover, no attempt is made to present a complete list, many forms of mills being on the market which may be equally as good as those named.

Of side-vane governor mills the Corcoran and Eclipse are excellent examples. Of centrifugal governor mill the Halliday and Althouse are good examples, the latter being folding and rudderless. The Buchanan is a good example of a special form of wheel dependent for its regulation on the tendency of the wheel to go in the direction it turns as the velocity and wind pressure increase. The Stover mill has a solid-sail wheel with vanes so regulated that it may be reefed, stopped, or otherwise controlled to go slowly in heavy winds. The Perkins mill has a solid wheel with metal vanes, and an automatic rudder, which also acts as an automatic regulator. This, like many of the more recent American mills with metal vanes, as the Aermotor, Gem, Crane, and Ideal, is back-gearred. The Aermotor is one of the most popular of this class of modern American windmill with steel vanes. The Leffel windmill has metal vanes made on a helical curve, and depends for regulation on the fact that the center line of the wheel shaft stands off from and parallel to the plane of the rudder.

Others of the modern American type of metal-vane wheels are the Cyclone and Woodmanse. The Advance is of the automatic-regulating rudder type, and has both steering vane and governing rudder. The Carlyle is a special type, having a rudder arranged to reef the sail in storms, and so attached by an adjustable cam as to cause the center of gravity of the rudder to rise as the rudder falls toward the wheel.

Drive wells should not, as a rule, be relied on to supply windmills, as the flow of water from such wells is usually limited, because of the small stratum of subsurface water from which they derive their supply. The well should be of ample size and properly lined. It is not infrequently necessary to place the pump down in the well if the depth of this below the surface is such that water can not be successfully raised by suction. The windmill should be placed directly over the well or other source of supply, and on a wooden or iron tower or scaffolding sufficiently high to raise the wheel 20 to 30 feet above all surrounding obstructions. As commonly constructed, this tower is supported on four inclined pillars which straddle the well, and on its top is built a platform or turntable with an open center through which the pump rod descends vertically to the reciprocating force pump in the well. Wooden towers of this form are built from 20 to 40 feet in height, with upright corner posts of 4 by 4 to 4 by 6 inch timbers, crossed-braced with 1 or 2 by 6 inch planks. The corner posts are usually firmly anchored and doweled into foot posts buried in the ground and made of 8 by 8 inch timber. Nailed to one of the side pieces is a ladder by which to reach the platform.

Windmill towers are now often built of angle steel varying in size from $2\frac{1}{2}$ to 4 inches, according to the size of the wheel and height of

the tower. These are in form more graceful than the wooden towers, and more stable, since they offer less resistance to the wind, and if properly proportioned should outlast wooden structures and withstand heavier gales. In the illustration (Pl. II) one of these towers is shown supporting a tank above which in turn is the windmill, this arrangement being adapted for village or domestic supply, combined with irrigation. In order to secure pressure for the former purpose the water is pumped by the windmill into the vertical pipe leading to the tank, but at the times when it is used for irrigation the water is not lifted to this elevation, but is only brought to a short distance above the ground, being allowed to flow out into an open pond or reservoir from which it can be drawn to the fields.

These steel towers are built as high as 100 feet, and at comparatively little cost, so that there is no difficulty in raising the wind wheel well above all surrounding obstructions. A recent development of interest in the construction of such towers is a tilting tower. This is constructed in such a manner that the upper part carrying the wheel can be tilted or brought down to the ground in a few moments and with little exertion, permitting easy adjustment and oiling. Metal towers are usually anchored on heavy wooden posts, or preferably in masonry, where the latter is easily obtainable.

In erecting either wooden or steel towers care should be taken to keep them plumb and to place the pump rod directly over the pump. Above the platform the horizontal crank shaft is supported in bearings on the upper movable part of the turntable and is connected with the pump by a swivel joint, in order to permit of rotation of the mill top in making necessary adjustments of the sails to changing directions of the wind. An overhanging arm of the crank shaft carries the wind wheel. This, in some forms of mill, is on the lee side of the tower, in which case it maintains its direction perpendicular to the wind by pulling the turntable around, and is rudderless. In other forms the pressure of the wind on a rudder vane of sufficient area and leverage to overbalance the wind keeps it nearly perpendicular to the direction of the latter and on the windward side of the tower. Most mills have, in addition, a controlling or regulating gear by which they can be stopped when the reservoir is full or repairs are necessary, and to prevent damage during gales. This gearing may be either automatic or operated by hand.

There are many varieties of force, siphon, and patent pumps used in lifting water by wind power. It is impossible to say which of these is best suited for general service. The irrigator will do well to leave the selection of the pump required for his particular conditions to the windmill maker, for every manufacturer of windmills is prepared to supply any of the standard pumps and is sure to suggest that type and size which he believes will best meet the requirements, that it may make the best showing for his mill.

Windmills average in cost from \$50 to \$400, according to size and

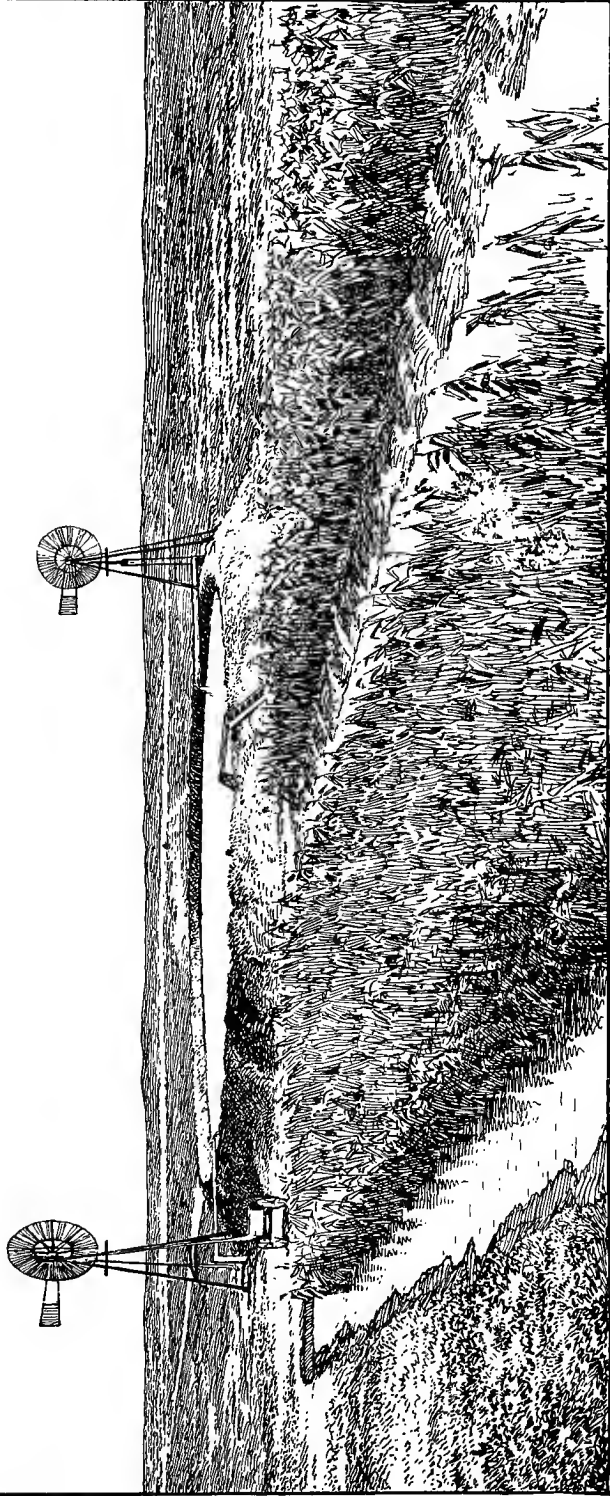

WINDMILLS AND CIRCULAR RESERVOIR.

make. Storage tanks or reservoirs may be built for \$100 and upward. The pump worked by the wind wheel should be of the best make and of a diameter not less than 3 inches and thence to 8 or 10 inches, certainly of sufficient capacity to handle all the water which the wind wheel is capable of lifting. On an average a 5-inch pump will discharge 250 cubic feet an hour, a 6-inch pump about 380, and an 8-inch pump 650. On this basis, and with the average water duty, a 5-inch pump will therefore irrigate 6 acres if running constantly, or 2 acres if running one-third of the time. The average windmill will irrigate from 1 to 3 acres. If it is supplemented by ample storage facilities these figures may be multiplied by 3 or 4. In other words, it will irrigate from 3 to 10 acres. There are windmills of sufficient size in the West, where the wind is amply steady, to irrigate, with the aid of storage tanks, from 5 to 19 acres, pumping from wells 30 to 150 feet in depth. Theoretically, a 25-foot windmill working eight hours a day for one hundred and twenty days will pump 40 acre-feet to an elevation of 25 feet, and if storage capacity for half this volume be provided it will be capable of irrigating about 20 acres.

An excellent example of a windmill pumping plant is that of Mr. E. E. Frizell at Larned, Kansas, shown on Pl. III. This consists of three 14-foot steel windmills on 30-foot towers and discharging into a reservoir 130 feet in diameter, with banks 8 feet high. The pumps have 10-inch cylinders, and with a lift of 25 feet can fill the reservoir in about two days. The available capacity of the reservoir is nearly 2 acre-feet (Pl. IV), and in a season the plant is capable of irrigating 60 acres successfully. When the reservoir is filled a sufficient head of water is available to enable it to flow freely over any part of the irrigable area and in sufficient volume to thoroughly soak the soil.

WATER WHEELS.

Water acts as a motive power by its weight or by its impulse. In the former case it falls slowly through a given height, and in the latter it passes through the motor with a constantly increasing velocity. Water motors may be divided into two classes, (1) water wheels and (2) water engines, each of which may be subdivided into several classes. Of water wheels the principal varieties are (1) undershot wheels, (2) breast wheels, (3) overshot wheels, (4) Pelton wheels, and (5) turbines. In addition there are water-pressure engines, rams, bucket engines, etc., but most of these are antiquated or not economical, and it is therefore hardly necessary to describe them as machines for elevating water for use in irrigation. Of these devices, however, rams are very economical where but a small volume is to be lifted.

In considering the subject of lifting water by means of water power, it may be said, as of other water-lifting machines, that the duty they have to perform may be the raising either of a large volume of water

to a small height or of a small volume to a large height. These duties may both be performed with a water power derived through either a large volume of water from a small height or a small volume of water from a great height. It is this intimate connection between volume and head of power and resulting work which calls for the exercise of discretion on the part of the irrigator in choosing the water motor best suited to his special requirements. A ram is nearly always called upon to utilize a large volume from a small height to raise a small volume to a great height. The Pelton water wheel generally utilizes a small volume from a great height to elevate varying volumes to varying heights. Undershot and breast wheels utilize large volumes from small heights to elevate moderate volumes to small heights.

Of undershot water wheels there are practically three varieties—midstream wheels, the common undershot wheel, and the Poncelet wheel. The midstream wheel is actuated by the velocity or impulse of a current of water in the middle of a broad stream in which it may be set. Such wheels are rarely employed, but when they are it is almost exclusively to raise water for irrigation. They are simple in construction and operation, and may be advantageously employed where water is abundant, even in streams having moderately low velocity. Such wheels produce the best result when their float boards or paddles are made straight, but not radial. They vary from 12 to 25 feet in diameter, their float boards varying between 10 and 15 in number, 2 of which should always be immersed at the same time. These project from 24 to 30 inches from the wheel rim, dipping into the water about one-half their depth. In rivers, the water levels of which fluctuate, the axle of the wheel is placed on movable supports, as shown in fig. 11, to render it capable of being raised or lowered at pleasure. An interesting adaptation of the midstream wheel for lifting water for irrigation is that illustrated on Pl. V, which represents such a wheel floating in the Colorado River, and by means of gearing and an endless cable, causing buckets attached to an endless chain to lift water from the river to the irrigating ditch above, a height of about 25 feet.

Numerous midstream wheels have been employed in the West for pumping irrigation water. They are almost always used as norias, having attached to their outer rims a number of buckets which dip into the water as the wheel revolves, and, as they reach the upper portion of their cycle, spill their contents into a trough which leads into the irrigation ditch (Pl. VI). Such wheels are of very ancient origin, having been used in almost every country in the world, most extensively, perhaps, in Egypt and Italy. Some very large wheels of this variety have been successfully employed on the Green River in Colorado. The diameters of these wheels are from 20 to 30 feet; they are hung on wooden axles 5 inches in diameter, and their paddles dip 2 feet into the stream. The buckets attached to their outer circumferences are of wood, having an air hole in the bottom closed by a suitable

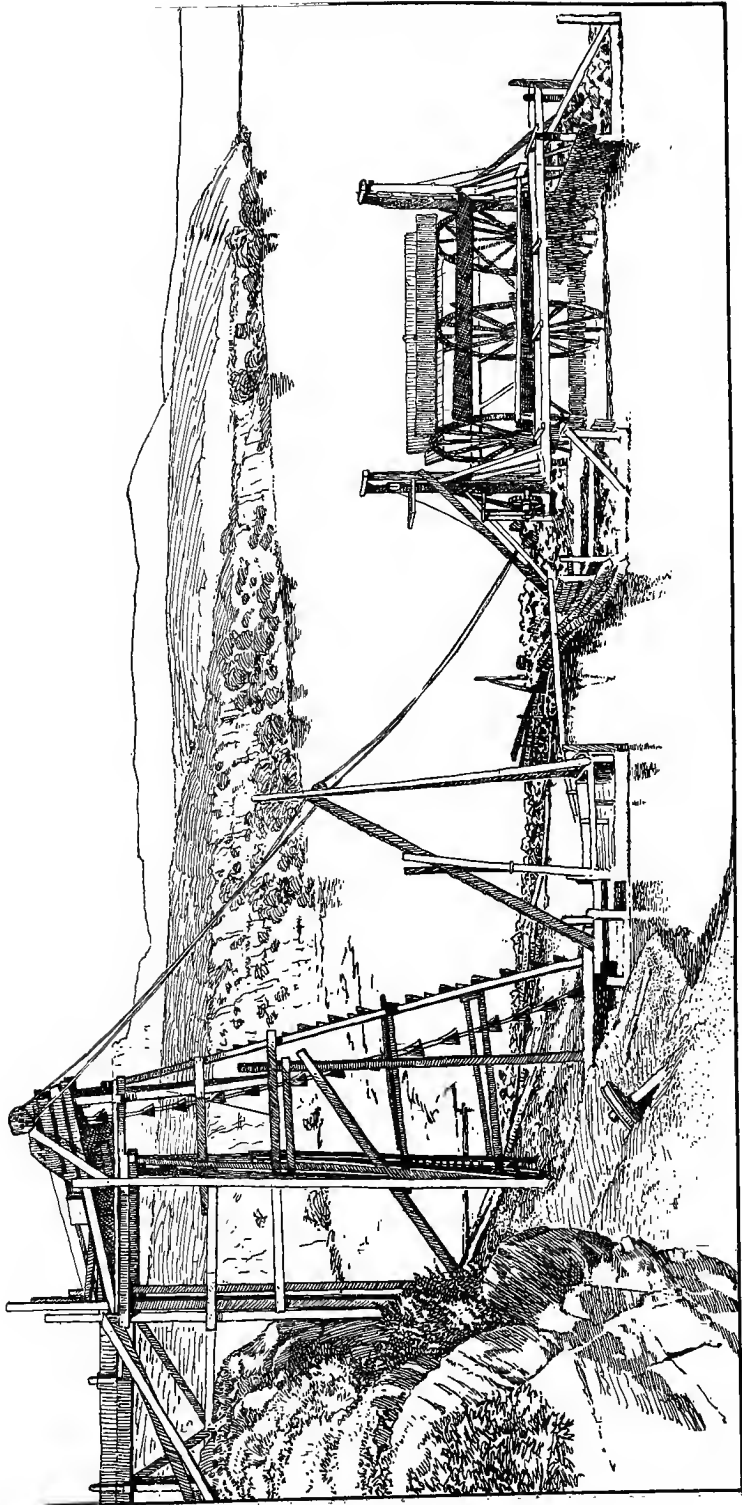

MIDSTREAM WHEEL DRIVING A BUCKET PUMP.

leather flap valve. These buckets are 6 feet in length and 4 inches square, and have a capacity of two-thirds of a cubic foot each. The largest of them raises 10 cubic feet per revolution, and handles in all about 4,000 cubic feet per day, or, approximately, one-tenth of an acre-foot. An apparatus not unlike the *noria* is the ancient wheel employed in Egypt and known as the *tympanum* (Pl. VII). This wheel is a common undershot wheel turned by paddles dipping into a flowing stream, but instead of lifting water in buckets, the water enters a series of spiral gutters, and as the wheel revolves flows through these until it finally reaches the center of the wheel near the hub and passes out at this point into the irrigation ditch.¹

Common undershot water wheels are better than midstream wheels where a fall of sufficient height to give a good velocity can be obtained. These are placed in a channel or mill race of about the width of the wheel, but a little wider at the inlet than at the wheel. The paddles

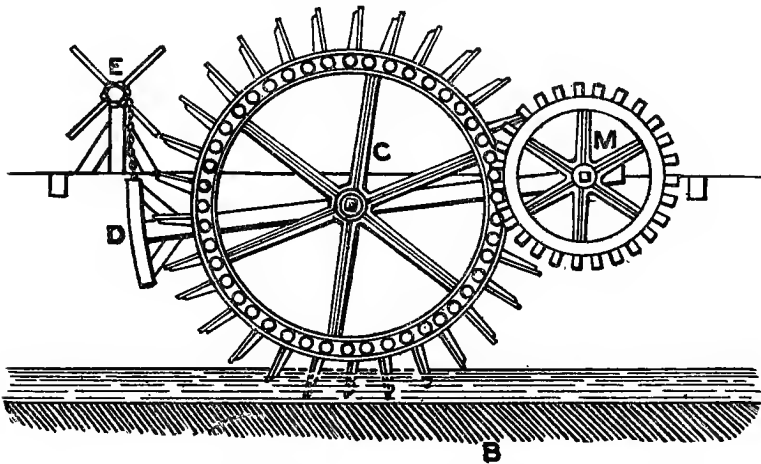

FIG. 11.—Undershot water wheel.

are similar to those of midstream wheels, though they are sometimes curved and of iron (fig. 11). They vary in diameter from 10 to 20 feet and have usually from 30 to 40 paddles of from $1\frac{1}{2}$ to $2\frac{1}{2}$ feet in depth and with face lengths of from 2 to 6 feet. In the illustration, fig. 11, a simple form of undershot wheel is shown, diagrammatically, exhibiting a common method by which the wheel can be raised or lowered to suit the fluctuating height of the stream. The axle of the paddle wheel (C) is supported at about the middle by heavy timbers (D), the ends of which on the downstream side are pivoted in line with the axle of the wheel (M), which transmits the power. The upstream ends of the timbers are hung on chains passing over a windlass (E), by which the timbers can be hoisted or lowered, thus adjusting the height of the paddles. Greater

¹ A form of wheel similar to this, carrying the water through curved pipes instead of rectangular compartments, is illustrated in the *Scientific American* of September 5, 1896, page 17.

efficiency can be obtained from undershot wheels if the paddles are made concave or of the type known as Poncelet. These latter are immersed nearly to the height of their axle, the water being partially screened from them by a curved breast-piece or apron, so that the current impinges against the curved blades somewhat in the manner of the action in a turbine.¹

Overshot wheels are economical in their use of water, and are therefore employed where it is scarce. In these the water is delivered above

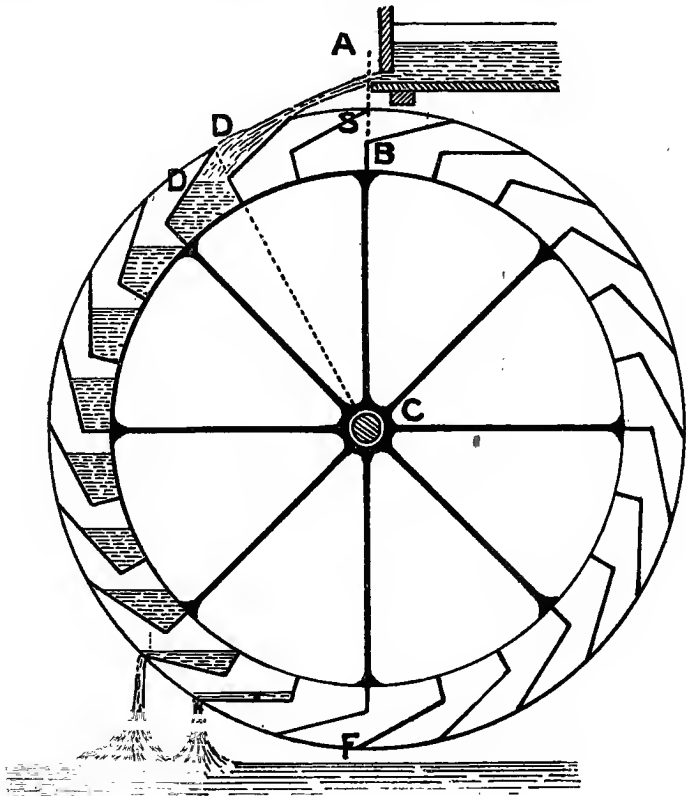
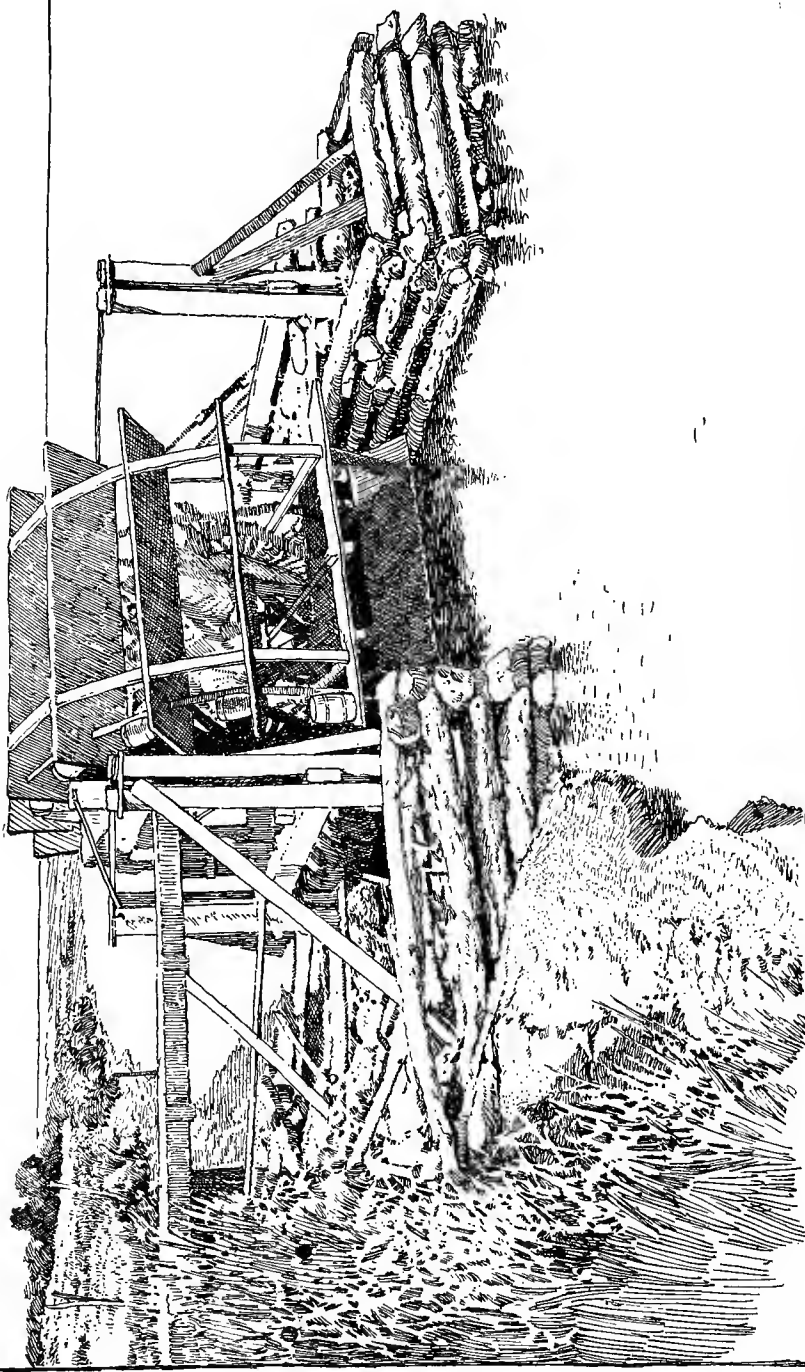

FIG. 12.—Overshot water wheel.

the wheel by means of a flume, mill-race, or penstock, and they are so constructed that the water may be thrown upon either the near or the far side of the wheel, according to the arrangement of the outlet gates controlling the supply. On the outer circumference of the wheel is a series of buckets of the full length of the wheel face. Into these buckets the water pours, and by its weight carries the wheel down, causing it to revolve (fig. 12). As it turns, each bucket (D D) fills in passing the

¹ The Mechanics of Engineering and of Machinery, Weisbach and Dubois, Vol. 2; John Wiley & Sons, 1889, page 316.



NORIA, OR WATER WHEEL, LIFTING FILLED BUCKETS.

inlet orifice (A) and empties as it approaches the outlet channel, so that on one side are always a certain number of filled buckets. Such wheels may be employed to utilize falls of from 6 to 60 feet. In order to lose as little of the fall height as possible, the bottom of the wheel should approach close to, but not dip into, the lower water surface. The greater the width of the faces of these wheels the larger volume will their buckets hold, and, accordingly, the greater power will they exert. Overshot wheels may be employed to operate, through gearing or belting, any of the usual forms of reciprocating, centrifugal, or force pumps, and they will elevate volumes of water to heights proportional to the power which they are capable of developing. The largest, and therefore, perhaps, the most interesting, overshot wheel ever constructed is on the Isle of Man. The diameter of this wheel is 72 feet and 6 inches, and it is claimed to develop 150 horsepower, which is transmitted several hundred feet by means of wooden trussed rods to a series of pumps capable of raising about 33 cubic feet of water per minute to a height of 1,200 feet.

Turbines are horizontal water wheels and may be classified according as they are acted upon—(1) through impulse, (2) through pressure, or (3) through reaction. Impulse wheels have plane or concave vanes or float boards on which the water strikes more or less perpendicularly. Pressure wheels have curved float boards along which the water glides. Reaction wheels are actuated by an arrangement of pipes from which water issues tangentially. To this latter class belong Pelton and other forms of tangential wheels. Pressure and reaction wheels, though similar in construction, differ in that in the former the passages between the vanes are not completely filled with water, while in reaction wheels the water fills and flows through the whole section of the discharge pipe. Turbine wheels are again subdivided into the following three classes: (1) outward flow, (2) inward flow, (3) mixed or parallel flow, the latter really combining the first two classes. Outward-flow turbines receive the water at the center and deliver it at the periphery of the revolving wheel. Inward flow turbines act in practically the reverse manner from that of outward-flow wheels.

Turbines possess an advantage over the older types of wheels in that they may be used with any fall of water, from one to several hundred feet. They have many other advantages over such water wheels; they may be regulated according to the power required and the water supply available, the regulating apparatus being such that the efficiency remains nearly the same, whether water is scarce or abundant. Again, turbines may be submerged, while other forms of water wheels must be elevated above the tail-race. The turbine takes its supply at the bottom of the fall, while overshot water wheels take it from the top of the fall, thus the former utilizes practically the whole height of fall. Furthermore, turbines move with a greater velocity than vertical water wheels, and hence may be materially reduced in size and weight for an equal

production of power. In fig. 13 a turbine is shown geared to a centrifugal pump, as employed in irrigation.

There are a number of successful forms or types of turbine water wheels made in this country. The advantages of each of these are fully described in the trade catalogues of the various makers, and much additional useful information relative to them can be obtained by the prospective irrigator through correspondence with the manufacturers. In the West are a number of irrigation pumping plants operated by turbines. The wheels range in size and power from a few inches in diameter, operated under but a few feet of head, and developing a fraction of a horsepower, up to enormous engines rivaling those recently built for utilizing the fall of Niagara, capable of producing as much as 2,000 horsepower each, and operated under several hundred feet of head, their

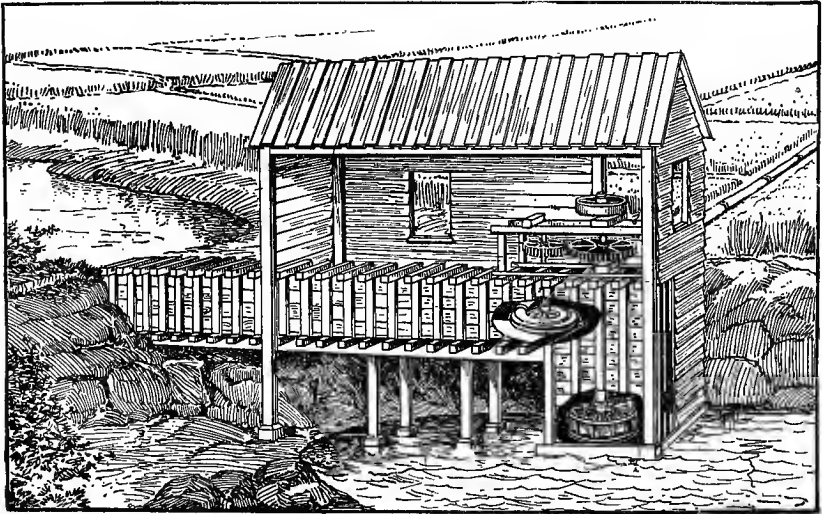
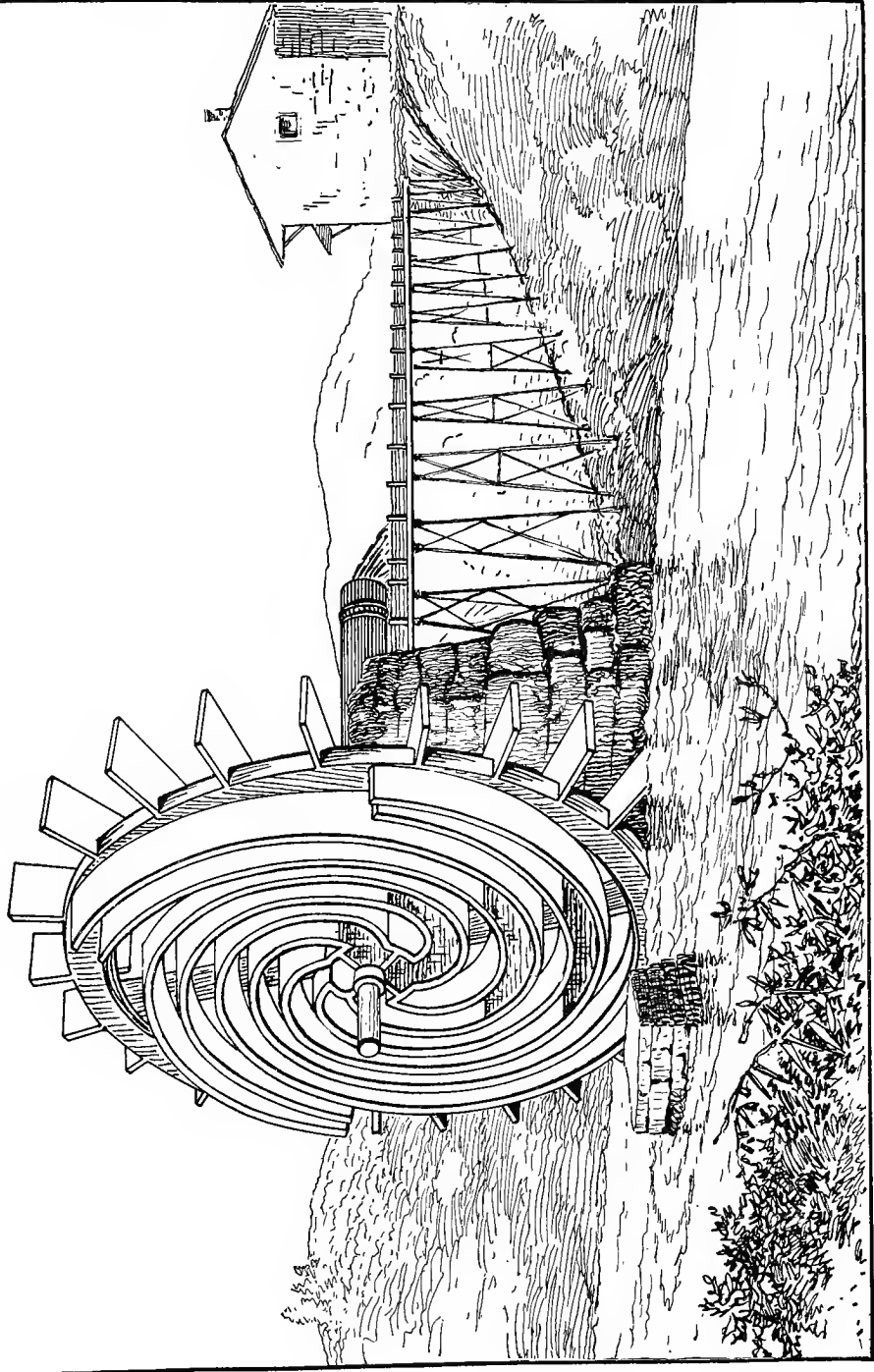

FIG. 13.—Turbine wheel driving centrifugal pump.

diameters being as great as 6 to 8 feet. They range in price, likewise, from \$100 to several thousand dollars. There has been recently erected at Prosser Falls, Washington, a turbine power and pumping plant capable, it is estimated, of irrigating 4,000 acres besides furnishing power for factories and other purposes. This plant pumps water to an elevation of 100 feet, with a power-producing fall of 20 feet. There are two turbines, each 48 inches in diameter, and each capable of developing 135 horsepower under a 12-foot head. Each operates a duplex pumping engine of 25-inch cylinder and 24-inch stroke, each having a capacity of 4,000 gallons a minute.

Tangential water wheels are simpler in construction than turbines, less liable to get clogged or out of order, and they may be worked under much greater heights of fall than other forms of water wheels. They derive power from the impulse of water discharged from a nozzle



TYMPANUM.

at buckets on the lower side of the wheel (fig. 14). They do not work so satisfactorily as turbines with heads less than 30 feet, though they produce small powers with great efficiency at even lower heads. But above 50 feet and up to 2,000 feet there is no other water wheel so efficient as the tangential. It has a wide range of adaptability to varying conditions of water supply by simply changing the nozzle tips. As the buckets are open, there is no uncertainty from derangement of parts or stoppage by driftwood. They are relatively cheap of installation, and admit, by varying their diameters, of being placed directly on the crank shaft of power pumps without intermediate gearing. The Pelton is the most common form of tangential wheel.

Few Pelton wheels have yet been employed in pumping water for irrigation, but as they become better appreciated it is probable that their value in utilizing small volumes of water from great heights will

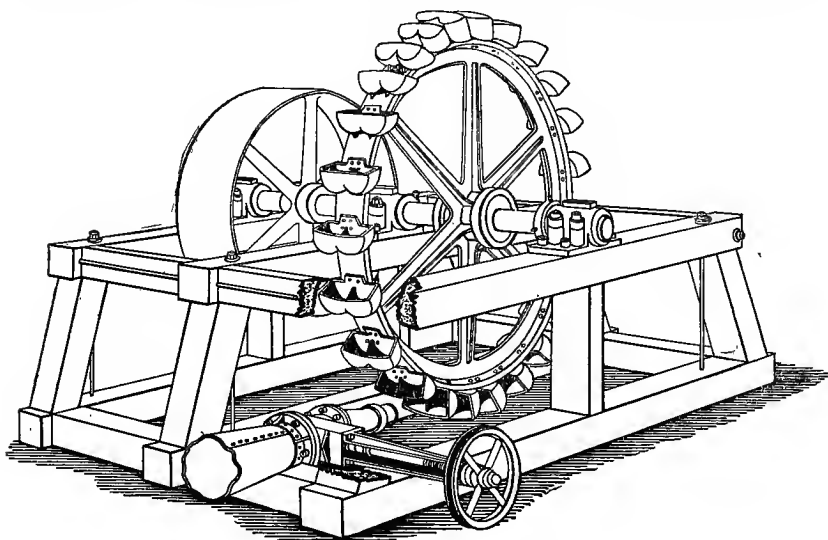

FIG. 14.—Pelton water wheel.

render them more popular. Pelton wheels are made of varying sizes, from those capable of developing a fraction of a horsepower from the water supply of a house faucet or mountain spring to the largest size. That recently constructed for the North Star Mining Company, Grass Valley, California, operated under an effective head of 750 feet, is $18\frac{1}{2}$ feet in diameter and of 300 horsepower capacity. This wheel is mounted on a bicycle-spoked frame having a 10-inch steel shaft. Its peripheral speed is 6,000 feet a minute, and its efficiency is about 90 per cent. Another Pelton wheel working under 810 feet head is but 40 inches in diameter and develops 600 horsepower.

There is now being made by the Austin Manufacturing Company, of Chicago, an apparatus called the Improved Current Motor, the object

of which is to develop power from the water flowing in a large stream something in the manner in which it is developed by the ordinary undershot water wheel. This apparatus consists of a narrow, floating, scow-shaped pontoon, a sort of floating platform, about 100 feet in length by 11 feet in width. The upstream end of this is pointed like the prow of a boat, that it may part the current of the stream. This float is anchored in midchannel and carries a couple of endless chains running over sprocket wheels 5 feet 6 inches in diameter hung on 2-inch shafts. These sprocket wheels are situated at each end of the pontoon, and the endless chains bear between them, at intervals of 8 feet, float boards 6 feet $10\frac{3}{8}$ inches in length by 3 feet in depth. These float boards are acted upon by the current, which carries them along beneath the pontoon, over the rear sprocket wheel, whence they return above the plat-

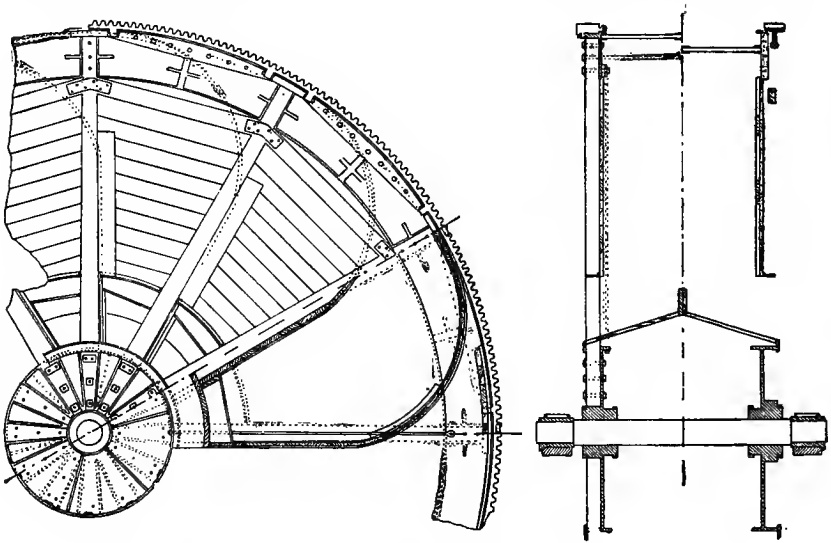

FIG. 15.—Wheel for lifting water on Chesapeake and Delaware Canal.

form to the front sprocket wheel and again pass into the water. The power developed by this motor is transmitted by belting and gearing to an ordinary endless chain carrying buckets or other mechanical water elevators (see p. 51) which lift the water from the stream into the irrigating canal.

A curious and at the same time interesting form of water wheel, which is not a water motor, but is used to lift or pump water, is one which is employed on the Chesapeake and Delaware Canal to elevate water from a lower to a higher level. This wheel (fig. 15) is similar in its mode of operation to the tympanum of Egypt, shown on Pl. VII. It is 39 feet in diameter, 10 feet in width on the outside, and $7\frac{1}{2}$ feet on the inside. Of its face width 24 inches is occupied by two bands or rows of heavy iron cogs, which bind the outer edges of the wheel.

This revolves on a 15-inch iron axle, reduced at the bearings to 12½ inches, and is turned by a couple of cogged pinions, each 4 feet in diameter, mounted on a 12-inch crank shaft. These pinions gear into the cogged bands on the outer edges of the wheel. The shaft bearing the cogged pinions is connected directly, through cranks, with two large low-pressure condensing beam engines. These engines have each 7-foot stroke and 36-inch cylinders, and are each capable of developing 175 horsepower, or a total of 350, on a consumption of 900 pounds of coal per hour. The central portion of the wheel, 8 feet in width on the face between the cogged bands, is divided into twelve openings, each about 18 inches wide at the mouth, and these are the entrances to spirally curved buckets of the full width of the wheel, which enlarge as they approach the center and then diminish at their inner or discharge orifices to a width of 2 feet. Surrounding the main axle is a conical wooden hub, from 8 to 11 feet in diameter, so designed that the water falling on it from the buckets is thrown in either direction and empties into two canals, one leading away from each side of the wheel, discharging a little beyond into the main canal. The buckets terminate within 4 feet of this central hub, and have an inside depth along the diameter of the wheel of 12 feet. As the wheel revolves, the buckets fill by immersion in the feeder canal, and the water falls out at the lower end of these buckets onto the hub and thence into the out-take canals. The lift from the surface of the feeder canal to the surface of the out-take canal is 14 feet. The wheel makes 100 revolutions per hour, and is capable of lifting 300,000 cubic feet of water per hour to this height. This is equivalent to about 170 acre-feet of water per day of twenty-four hours, or about 83 second-feet flowing continuously. This, on a consumption of about 10 tons of coal for twenty-four hours at \$5 per ton, or \$50, is equivalent for fuel alone to a charge of about \$1.30 per acre-foot. The efficiency of this machine seems to be relatively so high as a pumping machine for low lifts and large volumes that it is not improbable that it may be found advantageous to employ some such apparatus in irrigation.

Hydraulic rams may be utilized where there is a trifling fall and but a small amount of water is to be lifted. They work on the principle of a large volume of water having a small fall forcing by impulse blows a smaller volume to a higher elevation. Water is delivered to the ram from a reservoir or stream with steady flow through the supply or drive pipe. At the end of this is a check valve, opening into a chamber connected with the discharge pipe. As the water passes through the drive pipe it flows, with a velocity due to its height of fall, through a weighted pulse or clack valve which opens inward. It almost instantly closes this valve, and at the moment the issue of water ceases a ramming stroke is created which opens the delivery valve and permits the water to enter the air vessel, and at the same time, because of its velocity, the water flows back through the drive pipe. At the instant the backward flow begins the delivery valve closes and the pulse valve opens

to allow the passage of the water from the supply pipe, and the operation is repeated. In general, it may be stated that a hydraulic ram will elevate one-seventh of the supply volume of water to a height five times the fall, or one-fourteenth part to ten times the height of fall. The fall should range from 2 to 10 feet, but not more. Hydraulic rams are very cheap, both to purchase and to maintain, and are unaffected by tail water, as they will continue working even when flooded. It may be stated that in placing a hydraulic ram the length of drive pipe should be increased as the height to which water is lifted is increased, so that water shall not be forced back in the drive pipe as the pulse valve closes. The length of the drive pipe should in general be five to ten times the height of fall. The delivery pipe is usually from one-third to one-fourth the area of the drive pipe.

Of the many types of hydraulic rams in the market but few are of

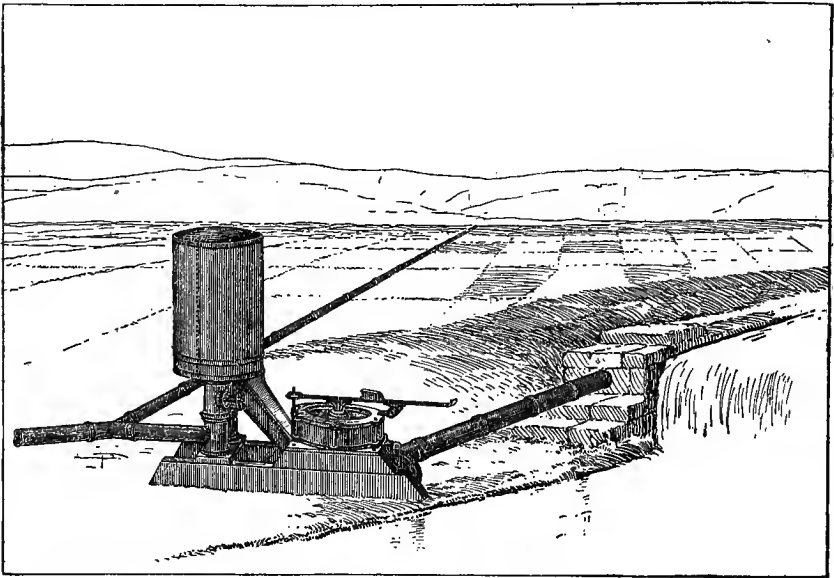

FIG. 16.—Hydraulic ramming engine.

sufficient capacity to perform the amount of work required in supplying irrigation water. Those which are capable of performing this work partake chiefly of the nature of hydraulic ramming engines, and are constructed somewhat differently from rams proper. They may be actuated by dirty as well as clear water, but are more intricate in their construction than are simple rams. One of the most effective of these engines is the Rife hydraulic ramming engine (fig. 16). This is said to be capable of elevating water to a height of 25 feet for every foot of fall, and to deliver one-third of the water used in operation to two and one-half times the height of fall, or one-sixth of the water to five times the height of fall. Only the largest of these are capable of elevating enough water for irrigation. Those having a drive pipe 8 inches and a

delivery pipe 4 inches in diameter are capable under a head of 10 feet of elevating about one-half of an acre-foot per day of twenty-four hours to a height of 25 feet. Such a machine costs \$500, or at the rate of about \$10 per acre irrigated.

HOT-AIR AND GASOLINE PUMPING ENGINES.

These machines have been extensively used in the East for pumping moderate quantities of water for domestic consumption and for small factories or villages. Lately they have been successfully employed in pumping small irrigation supplies in the West, and are undoubtedly destined soon to gain popular favor, chiefly because of their simplicity, economy, and the ease with which they can be stopped and started and maintained in successful operation by unskilled labor. Hot-air pumping engines do not depend for their operation on power developed by the expansion of steam to convert heat into motion. Gasoline engines are likewise operated without converting the heat into steam, but by the expansive force produced by the explosion of vaporized gasoline when ignited in contact with air. Both of these types of engines are made only to develop comparatively small powers, and therefore are utilized in pumping but comparatively small volumes of water, usually irrigating from 5 to 50 acres. These engines have decided advantages over water and steam motors in that they can be employed where there is not sufficient water supply to operate a water motor and because of the kind of fuel which they consume, gasoline engines being serviceable in arid regions where fuel is expensive and difficult to obtain, and hot-air engines being capable of utilizing almost any variety of fuel. Moreover, these engines are small and compact, simple of erection by comparatively unskilled labor, and may be operated with the minimum expense for supervision and with little skill on the part of the operator.

Hot-air engines are constructed almost wholly for pumping purposes, the motive power and pumping apparatus being combined in one machine inseparably connected in one frame. They are so simple in operation that anyone capable of lighting a match may run them. There is no possibility of explosion, and when once started they require no further attention than for replenishment of fuel. They are made in capacities ranging from a few gallons per minute to one-tenth of a second-foot, equivalent to two-tenths of an acre-foot per day of twenty-four hours, limited by the height of lift, which varies from a few feet to 500 feet. The chief objection to hot-air pumping engines is their great first cost, which for the larger size is \$600, or \$6,000 per second-foot, equivalent to about \$100 per acre irrigated.

Gasoline engines are used extensively in some portions of the West, notably in Kansas, for pumping water for irrigation. They are made of various dimensions, up to those capable of developing 50 horsepower and pumping a correspondingly large volume of water, and they are

constructed as combined motive and pumping plants or as separate motors to be attached to varying forms of pumps. The chief advantages which these machines have over other motive powers for pumping are their compactness and simplicity of installation and operation, and, above all, their cheapness, not so much for first cost as for ultimate maintenance, though in this latter item they do not surpass hot-air pumping engines. The largest of these engines are capable of elevating for low lifts as much as 3 second-feet of water, or 6 acre-feet per day of twenty-four hours, and lesser quantities to greater heights in proportion. The cost of operation of such a machine as this has been asserted to be for gasoline as low as \$1.25 per day, or 20 cents per acre-foot. It is stated that these engines will pump water at a cost of about 1 cent per hour; and working ten hours a day, the largest size will elevate sufficient water to a height of 20 feet to irrigate about 320 acres if storage be provided. The first cost of the plant is from \$400 to \$600 for engines capable of irrigating 10 to 20 acres, and larger plants in proportion. This is at the rate of about \$30 per acre without storage, and the cost of operation is about \$1.25 per acre irrigated.

STEAM PUMPING ENGINES.

Of the many forms of motors utilizing steam power, the following two classes cover most of those which are of interest to irrigators: (1) those which utilize steam power by indirect transmission to the pump through gearing, belting, or other separable connection; (2) those which utilize steam power through an engine directly coupled with the pump, as direct-acting or fly-wheel pumping engines. It is not desirable to refer here to the many forms of steam engines and boilers employed in developing steam power for actuating plunger, centrifugal, or other pumps. They are innumerable and are manufactured in all varieties, forms, and sizes and at all prices. The irrigator must determine by consultation with makers of steam engines and boilers those which are best suited to the work which he has to perform. On the other hand, direct-acting engines, being inseparable from their pumps, may be here considered, as each differs not only in its motive power but in its pumping mechanism.

In endeavoring to determine the power required of a pump that it may elevate a given volume of water to a given height the same considerations must be dealt with as in transforming power developed by windmills or water motors into volumes lifted to given heights. This may be roughly stated by the formula: horsepower required, H. P., equals time of work in minutes, t , multiplied by volume of water in cubic feet, v , multiplied by weight of a cubic foot of water ($62\frac{1}{2}$ pounds), w , divided by 33,000 pounds, the result to be multiplied by the height to which the water is elevated in feet, h , plus the resistance due to friction in pipes, f .

$$\text{H. P.} = \frac{62\frac{1}{2} t v}{33,000} \times h + f$$

The frictional resistance to flow is an indefinite quantity which may

be most easily determined by reference to such tables as Trautwine's or others giving fractional resistance for pipes of given diameters and lengths.

Direct-acting steam pumping engines differ from other steam pumps in that the motor and pump are combined inseparably in one mechanism, the power which performs work being derived from an ordinary steam boiler, not through an engine separately geared or belted to the pump, but directly from pump plungers which form part of the steam piston or connecting rod. Such direct-acting pumping engines may be either single or double acting. They have the water and steam ends centered in one line, so that the water plunger and steam piston are attached to the same piston rod and work together without an intervening crank or other connection. This is the simplest and most compact form of steam pumping apparatus, and is more extensively used for pumping than all other varieties of pumping machinery combined, though it is, perhaps, one of the most wasteful and expensive forms of steam engines. It is undoubtedly the most substantial and satisfactory form of steam pumping apparatus for lifts exceeding 20 feet, for it is less liable to derangement or accident and better fitted to perform constant, hard work than any of the separable steam engines and pumps. Machines of this class are manufactured by many establishments, and the qualities and efficiencies of the various makes are well established by competition and experiment. Steam pumping engines are similar in nearly all the various makes, differing chiefly in details of valve motion. Among the best of these are the Knowles, Blake, Smith-Vaile, Dean, Cameron, Worthington, and Davidson valve movements.

In selecting steam pumping engines, among the points most desirable are strength and simplicity of working parts, large water-valve area, long stroke and ample wearing surfaces, continuity of flow, simplicity of adjustment and repair, and moderate steam consumption. In choosing from the various makes of pumping engines it is well in corresponding with their makers to inform them, among other points, of the purposes for which they are to be used, height of lift and height to which water is to be forced, quantity of water to be elevated, motive power, and quality of fluid, as clear or muddy.

Direct-acting steam pumping engines may be either high-pressure or compound. The latter are economical in both fuel and water consumption, and their cost for operation is correspondingly less, though their first cost is a little greater. The best form of direct-acting are the duplex pumping engines, consisting of two direct-acting steam pumping engines of equal dimensions, side by side on the same bed-plate, with a valve motion so designed that the movement of the steam piston of one pump shall control the movement of the slide valve of its opposite pump so as to allow one piston to proceed to the end of the stroke and come to rest while the other piston moves forward on its stroke.

All single-acting pumps should be provided with air chambers.

These are often an improvement even to double-acting pumps, for though the latter have a fairly steady discharge, the air chamber insures almost perfect uniformity of delivery. The capacity of an air chamber for a pair of double-acting pumps is about five or six times the combined capacities of the water cylinders, while for a single-acting pump it may be ten or twenty times greater. The air chamber performs practically the office of a stand-pipe attached directly to the pump. It neutralizes the variations of velocity of discharge in the delivery pipes, the fluctuations of which might cause danger of ramming and wastage of work. The air chamber obviates this by permitting the excessive delivery of water from a pump stroke to enter it and thus compress the air, while on the return stroke the expansion of the air forces out water to supply the deficiency.

Several extensive steam pumping plants have been employed in the West for providing water for irrigation. The first cost is usually a little greater than for centrifugal pumps, though not always so, depending upon the height of lift. Their efficiency is usually quite high as compared with all other forms of pumping plants, and their maintenance cost is usually less than that for centrifugal pumps. Their operation requires skilled labor, as does that of centrifugal pumps; but they are less liable to get out of order, and any injuries sustained can usually be readily repaired.

In Arizona is a high-pressure pumping engine capable of irrigating 100 acres per season which cost when erected \$1,000, or \$10 per acre irrigated, while the cost of running it is but \$5 per acre. A larger and more modern plant operated near Tucson consists of two compound Smith-Vaile pumping engines, capable, it is claimed, of irrigating 600 acres per season at a cost for operation of \$3 per day, the first cost for this plant laid down having been \$4,200, and the height of lift being 70 feet. Still another pumping plant, consisting of an automatic cut-off condensing engine with two 150-horsepower boilers, has been erected on the Yuma River. The pumping engine has 18-inch stroke and 42-inch cylinders, and is of 165-horsepower capacity. This is an Allis pumping engine, having a fly wheel weighing 7 tons and making 67 revolutions per minute, the capacity of the pump being 12 second-feet, or about 24 acre-feet in a day of twenty-four hours. This pump delivers water through a 26-inch redwood stave main, elevating the water 80 feet, and this is stored in a reservoir having 23 acre-feet capacity. A year's test of this engine, according to the claims of the owners, shows it to be capable of discharging 12 second-feet at a cost of \$3 per second-foot for fuel.

There has recently been erected at Eureka, Kansas, a pumping plant for the irrigation of about 3,000 acres. This consists of two horizontal return tubular boilers and two compound, duplex, direct-acting steam pumping engines of a maximum capacity of 530,000 cubic feet, or about 12 acre-feet per day of twenty-four hours, equivalent to 6 second-feet,

with a total lift of 65 feet. The cost of this plant, exclusive of the storage reservoir, was about \$8,000, while the cost for operation is estimated to be \$1.60 per acre, assuming that the full area is covered.

In addition to the better-known forms of steam pumping engines, there have been built a number of patented types of pumps, gotten up with the special view of lifting large volumes of water to small elevations for use in irrigating or in draining lands. Three of the more notable of these are the Huffer and Nye irrigating pumps, formerly made in Colorado, and the Menge irrigating and drainage pump, made in New Orleans. The Nye pump is a curiously compact affair, worked directly from a steam boiler in such manner as to utilize atmospheric pressure in producing power through condensation of steam. It requires little steam pressure except for lifts above those made by an atmosphere, say over 25 feet at sea level. It consists of two large cylinders fastened vertically on one bed-plate. Steam is let into one of these and is instantly condensed by a spray of water, thus creating a vacuum or suction power nearly equal to atmospheric pressure, and the cylinder is filled with water. As one cylinder is being filled the other is being emptied, and at the same time receives steam for a similar condensation and vacuum. The action of the steam valves is automatic, and steam enters but one cylinder at a time. These engines have no pistons or packing to wear out and practically no loss of power by friction; they are simple in construction and erection, and little skill is required in placing or in operating them. They are made of varying sizes, the largest being capable of lifting nearly 7 second-feet of water to an elevation of 20 feet, and costing about \$1,000, equivalent to a first charge for plant of about \$140 per second-foot.

The Huffer pump works on a principle similar to that of the Nye pump, but while the latter is capable of forcing water to a height of nearly 100 feet by direct steam pressure, the Huffer pump is merely an atmospheric lifting pump, capable of raising water only to such height as the aid of atmospheric pressure will permit. The largest sizes of this pump are capable of lifting about the same volume of water as are the Nye pumps. Neither of these pumps has met with popular favor, chiefly because they are not economical motors. In consequence, their manufacture has been discontinued.

The Menge pump has been most extensively employed in pumping water from swamp lands or in lifting water to flood cranberry and rice swamps. Only recently have any of them been used for irrigation, and then only for low lifts, usually between 5 and 10 feet. Above the latter height a two-story or double lift may be employed, but is not quite so economical. For the lower lifts which are within the power of one pump this machine is considered one of the most economical made. It is a combination of wood and metal, and is operated by a stationary engine, belted to a pulley on a vertical shaft set in an upright wooden box. The upright box has two suction ports at the lower end, midway between which is the water wheel, from each blade of which is a free,

continuous delivery of water, which rises in the vertical box to the discharge outlet. These wheels are made in various sizes, from those which are but 4 by 8 inches up to wheels as great as 16 by 42 inches. The largest of these is claimed to be capable of lifting about 70 second-feet of water, equivalent to about 140 acre-feet per day, to a height of 10 feet on an expenditure of about 100 horsepower. The price of the Menge pump is exceedingly low, about \$1,000 for the largest size, equivalent to a first charge for plant alone of approximately \$14 per second-foot, plus the usual cost for steam boilers capable of producing this number of horsepower.

CENTRIFUGAL AND ROTARY PUMPS.

For lifting large volumes of water to moderate heights the centrifugal pump (fig. 13, p. 40) is most economical and efficient, as well as simplest in construction and cheapest in first cost of plant and erection. It is not, however, so substantial as a direct-acting steam pumping engine, and therefore not so suitable for large permanent works requiring considerable lifts. Where circumstances are suited to its employment it is one of the best pumps for irrigation. It is adapted to raising water heavily charged with sediment. In construction a centrifugal pump is similar to an outward-flow turbine driven in the reverse direction. Such a pump can not be put in action until it is filled with water, an operation which is effected through an opening in its outer casing when the pump is below water, or by means of a steam jet when the pump is above water. The efficiency of a centrifugal pump diminishes with the lift, and for lifts exceeding 25 to 30 feet a force or plunger pump produces better results. Centrifugal pumps are usually driven by water, steam, or gasoline motors, with which they are connected by belting or shaft and gearing, and they may be erected independently of the motors and at some distance from them (Pl. VIII). They are also made to gear directly on the motor shaft.

Many forms of centrifugal pumps are now in the market. They are of varying capacities, from those having 2-inch discharge pipes up to those having 24-inch discharge pipes, the largest sizes being capable of elevating as much as 15 second-feet, or the same number of acre-feet in a day of twelve hours. Such pumps as these vary in cost according to circumstances, but the larger sizes cost for plant about \$100 per second-foot of capacity for moderate lifts, while for 15 second-foot pumps they require engines capable of developing about 5 horsepower per foot of lift.

Among the more notable centrifugal pumping plants for irrigation is one for the Vermilion Canal Company in Louisiana, consisting of six 15-inch pumps, which are claimed to be capable of discharging 130 second-feet of water against a head of 20 feet, and are operated by two engines, each of 250 horsepower. Another centrifugal pump, working on a farm in southern Arizona and operated by a 10-horsepower engine

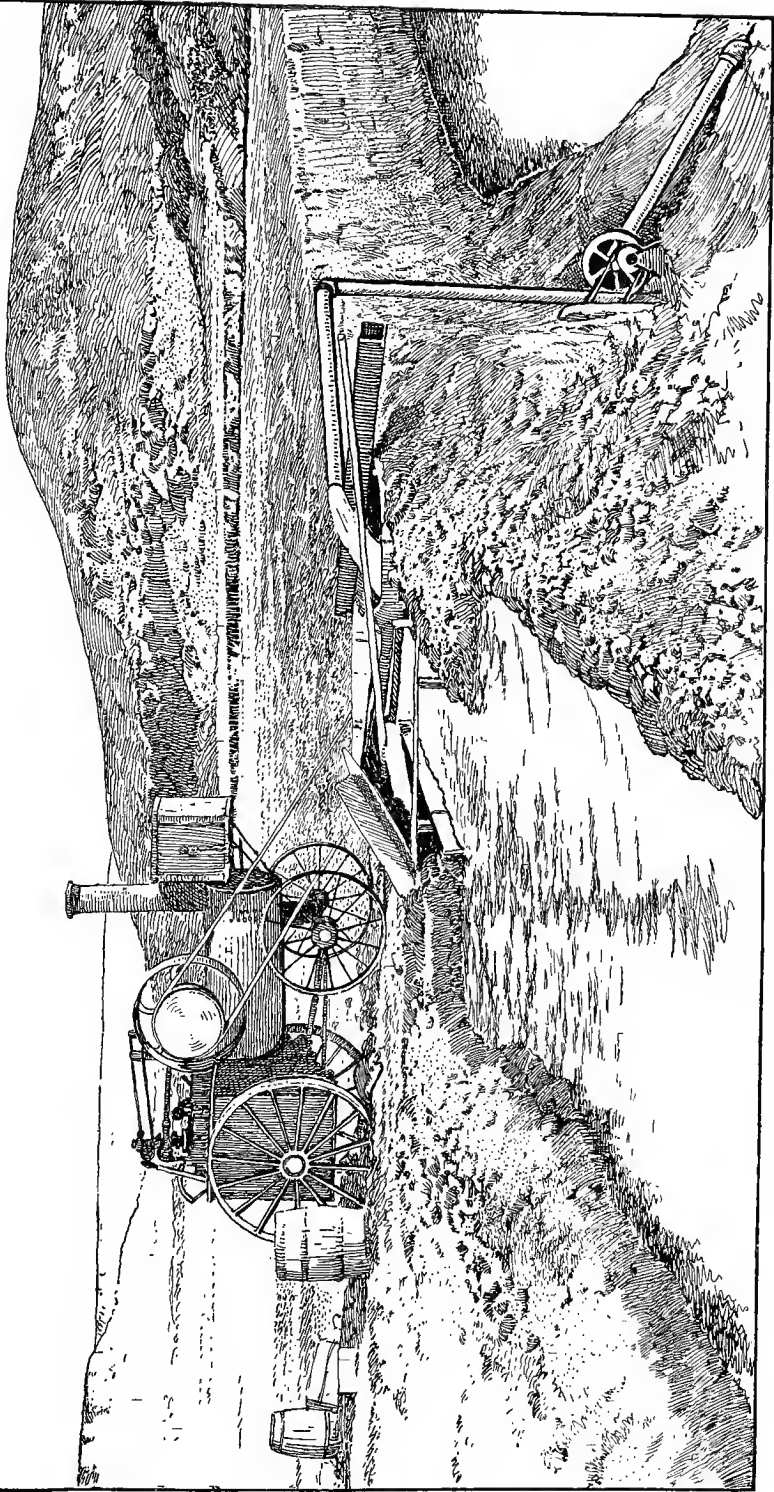

CENTRIFUGAL PUMP DRIVEN BY THRESHING ENGINE.

and boiler, has a capacity of two-thirds of a second-foot. The operation of this plant calls for the consumption of about 1 cord of wood per day of twenty-four hours, and it is capable of irrigating about 3 acres in a season. A similar pump in the same locality and operated by a gasoline engine of 35 horsepower will handle about $11\frac{1}{2}$ acre-feet in twenty-four hours on a consumption of about 84 gallons of gasoline. Other centrifugal pumps of small capacities and capable of watering 5 to 10 acres per day, and in the course of an irrigation season from 50 to 100 acres, are operated by one man at a cost of about \$2.50 per acre irrigated for maintenance and \$15 per acre for first cost of plant.

It is proposed to erect an extensive centrifugal pumping plant for the Summit Lake Water Company in California, and the estimates of the engineers for a plant capable of irrigating 40,000 acres, including distributing canals and other items, is \$81,000, the cost of the pumping plant alone being estimated at about 75 cents per acre, while the cost for operation of and interest on the pumping plant during an irrigating season is estimated to be about \$1 per acre, on the assumption that the depth of irrigation will be 1 foot and the lift 20 feet. These figures are considerably below those of most gravity systems.

Rotary pumps, while theoretically the most efficient, are practically capable of elevating but small quantities of water, and have been found of small value in elevating water for irrigation. They may be termed revolving-piston pumps in distinction from direct-action pumps, and have the advantage of not changing the direction of flow of water during its elevation by each stroke of the pump. They can be run at high speed, and have no complicated leather valves or pistons to be choked or otherwise get out of order. They are probably most useful in lifting silt-laden water or heavy fluids. There are numerous forms of these pumps in the market. A large machine of this type, made by the National Pump Company, is stated to be capable of lifting about 5 acre-feet of water in twenty-four hours to a height of 20 feet on an expenditure of about 5 horsepower, and to a height of 100 feet on an expenditure of 25 horsepower. The first cost of this machine is \$400, or about \$150 per second-foot. The efficiency of rotary pumps is low, there being an excess in driving power required over effective work performed.

MECHANICAL AND SIPHON ELEVATORS.

There are several varieties of mechanical water elevators, nearly all of which act on the principle of an endless chain carrying buckets. This endless chain revolves on two wheels, one at the upper end of the lift and one beneath the surface of the supplying well or stream. As the chain revolves, the buckets dip into the water and become filled, and as they reach the upper end of their revolution they spill their contents into a trough which leads it to the irrigating ditches. Two of the more popular patented varieties of mechanical water elevators are

the link-belt box water elevator and the Seaman irrigating pump. The link-belt box elevator consists of an elongated box which is set up in an inclined position over the water supply, at either end of which is a wheel of peculiar construction carrying on its periphery a metal link belt or chain, attached to which at short intervals are wooden projections of such dimensions as to fill the cross-section of the box. As the chain travels forward these projections are raised, carrying with them the water resting upon them until it reaches the upper end of the box, where it is discharged into the irrigating ditch. This machine may be operated by animal, steam, or water power, and the largest sizes are capable of lifting about 5 second-feet with an expenditure of 7 horsepower for a 10-foot lift. The highest practicable lift of these machines is 20 feet, and one of this capacity costs \$50 per second-foot.

The Seaman irrigating pump is similar to the apparatus just described, excepting that instead of a series of wooden flights or projections lifting water in a closed box it consists of a number of large galvanized iron buckets carried by the chain working in the open, the buckets being closed on all sides, with the exception of an opening on the bottom containing a ball valve retained by a little wire basket. When the bucket is filled the ball is pressed down in the basket so as to close the opening, and as the bucket reaches the upper part of its revolution the ball drops in the basket, permitting the water to flow out freely. The largest of these contrivances are capable of lifting about $1\frac{1}{2}$ second-feet on an expenditure of 5 horsepower, the first cost being about \$250.

There is manufactured in France, by Lemichel et Cie, an apparatus called a siphon elevator, which is claimed to attain an efficiency of 90 per cent. It consists of a siphon erected at a fall or dam in a river, at a reservoir dam, or in any situation where the lower discharge arm can be carried below the suction pipe so as to give a difference of elevation for the creation of siphon action. At the highest point of the siphon are constructed air and valve chambers, the effect of which is to relieve the siphon at that point of part of the water passing through it, only a portion passing on down through the longer arm of the siphon to keep up siphon action. It is this contrivance which enables water to be elevated by the siphon to heights as great as nearly 30 feet at sea level, instead of being delivered, as by common siphons, below the point from which it is derived.

The siphon elevator (fig. 17) depends for its efficiency on the operation of the air chamber or receiver and the regulator, which are placed at the upper bend of the siphon pipe. At the bottom of the suction pipe is a check valve which allows the ingress of water but prevents its escape. At the bottom of the lower arm of the siphon is a stop-cock which, when open, permits the escape of water, so that when it moves a vacuum is created behind it, which is filled with water, as in simple siphons. In action the siphon elevator must first be filled with

water, and as this descends in the lower pipe and ascends in the upper or suction pipe it passes through the receiver (*a*), where it reaches an open check valve which intermittently cuts off its flow into the regulator (*b*). The water forces this valve (*c*) forward until shut, and, its exit being thus cut off, its momentum raises a puppet valve (*d*) in the receiver held down by a spiral spring. Through this valve the water escapes into a storage tank or irrigating ditch. While the regulator is being partially emptied into the pipe a vacuum is caused, which creates a depression in the corrugated heads of the regulator, as in an aneroid barometer, and the pressure on the clack valve (*c*) being diminished, it is thrown open by a weight on a lever, permitting the water to fill the regulator once more and the corrugated heads to again assume their normal position. This vibratory motion occupies but a brief time, as many as 150 to 400 such pulsations taking place per minute, so that the flow of water is nearly continuous.

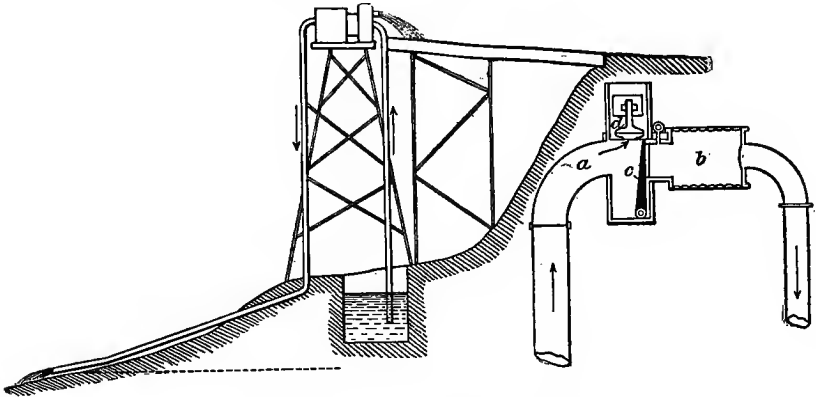

FIG. 17.—General view and detail of siphon elevator.

The capacity of these siphon elevators varies according to their dimensions and the height to which they elevate the water, but at sea level they have been built with capacities sufficiently great to elevate 8 acre-feet in twenty-four hours. This is a very large quantity when the simplicity of construction and cheapness of first cost of this mechanism—about \$1,200—are considered; and it may be safely stated that if further experiment with it shows it to be as effective as claimed in the past, it will be a valuable water-lifting apparatus where only trifling heights—say 10 to 15 feet—are to be overcome and there is sufficient fall and surplus water to permit of the wastage caused by the operation of the siphon. Batteries of two or three of these siphon elevators have been erected, one above the other, whereby, with additional wastage of water for each siphon, heights two or three times those to be effected by one siphon elevator have been obtained.

STORAGE RESERVOIRS.

The storage reservoir or tank employed to retain water which has been pumped when not required for irrigation should be situated at the highest point on the irrigable land. When there is but little slope to the land it may be impracticable to build an earth reservoir at a sufficient elevation to obtain a good head, in which case a wooden or metal tank should be used. Such tanks can be gotten from any of the windmill makers, and range from 10 to 30 feet in diameter, their depths varying between 3 and 20 feet and their capacities from 1,000 gallons upward. These tanks (Pl. II, p. 30), when constructed of wood, are made of the best selected clear pine and are bound by from 3 to 20 iron hoops, depending on the dimensions of the tank. Their prices range from \$30 to \$800 each.

Where artificial reservoirs can be constructed on the land, it is best, provided suitable material for rendering them impervious can be found, to build them up by constructing about the reservoir an embankment rather than by making an excavation in the ground. The reason for this is that the former mode of construction places the water surface at some height above the ground level and, besides making a larger volume of the water supply available, gives a better head for flowing it through the ditches. The most economical way in which to construct such reservoirs is to find a gully or depression of some sort in one of the higher portions of the land and build across the lower end of this an earth embankment. This is rarely possible on the level plains, where it is necessary to wholly surround the basin by an artificial embankment.

For the latter type of reservoir the best shape is circular, as such is more easily built and has a larger capacity for the same amount of material moved (Pl. IV, p. 34). The ground should first be deeply plowed and stripped of the surface soil, and this loose material be used as a portion of the outer face of the inclosing embankment. The cross-section of the latter should be rather flat, its slopes depending upon the nature of the soil. Where a firm, clayey gravel can be obtained, free of vegetable mold and other foreign substances, this will make one of the most impervious embankments. It may be given a cross-section as steep as about $1\frac{1}{2}$ horizontal to 1 vertical on the inside, and about 2 horizontal to 1 vertical on the outside, with a top width of not less than 4 feet. For less suitable material, as more sandy soil, or that containing some admixture of loam, flatter slopes must be used, reaching even as low as 3 horizontal to 1 vertical inside, and $3\frac{1}{2}$ or 4 to 1 on the outside. In every case such an embankment should be built up in horizontal layers, well and deeply bonded with the subsurface soil, these layers not exceeding 6 inches in thickness and being separately tramped by animals or rolled by heavy rollers as laid. If there is available a gravel containing sand and a little clay matter, the embank-

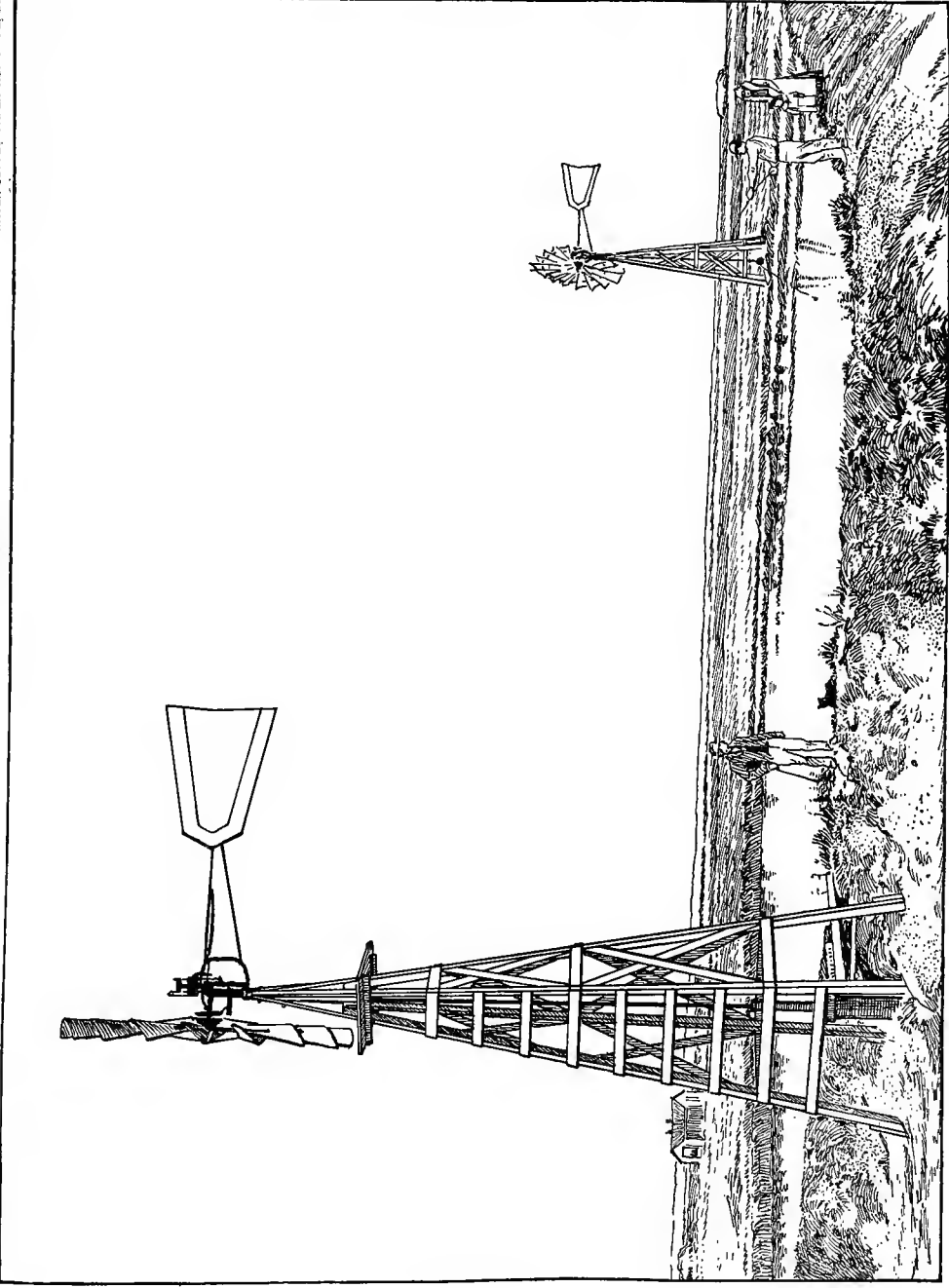

WINDMILLS AND RESERVOIR.

ment may be built up dry, and will form one of the most impervious structures that can be made. With less firm materials a puddle wall should be built up through the center of the bank as it is erected. Such a puddle wall should consist of gravelly clay, moistened as it is laid, and at least 2 feet in thickness for low embankments, its base being firmly and deeply bonded with the subsoil. The top of the embankment should reach at least 2 feet above high-water surface (Pl. IX), in order to prevent its being overtopped by waves during high winds, and the outer slopes should be sodded to protect them against erosion by heavy rainfalls. The reservoir should not be too large for the pump to easily fill, in which case the percentage of loss from evaporation and absorption would be too great. It should be as deep as practicable, for the deeper the less its area and the less the surface exposed to evaporation and absorption. A reservoir 100 feet in diameter and 5 feet deep will lose nearly all its water in a few months, whereas one 50 feet in diameter and 10 feet deep will lose scarcely 25 per cent by absorption and evaporation in the same time.

If homogeneous clayey soil underlies the bottom of the reservoir it will be unnecessary to provide a lining, though there may be some loss of water through percolation and absorption. If such a surface is not available for the bottom, the soil should be removed and the subsoil covered with a layer at least 1 to 2 feet in thickness of clay and gravel, the same being carefully puddled and rolled over the entire surface and up the inner slope of the embankment so as to make a firm bond with it. Better still, if means permit, is it to line the inner surface of the reservoir bottom and slopes with asphaltum. This is put upon the denuded subsoil much as is the asphaltum used in paving city streets. One of the best admixtures is about 75 per cent of La Petra asphalt, the remainder being of Las Conchas as a flux, both of which come from Lower California. This is boiled in open kettles for twelve hours at a high temperature, frequently stirred, and 20 per cent of it by weight is mixed with 80 per cent of sand previously heated to the same temperature. This should be put on with a thickness, for shallow reservoirs, of $2\frac{1}{2}$ inches, spread with hot rakes, tamped with hot tampers, and held in place on the slopes by anchor spikes of sheet iron about an inch wide and driven in at intervals of about a foot. This lining should be painted over with a bitumen paint or Trinidad asphaltum fluxed with residuum oil and poured on hot from buckets. Such a lining laid over a well-leveled and well-rolled surface will last many years, will be impervious to water, and as it will cost but 15 to 20 cents per square foot, will probably more than pay for itself in a short time in the saving of water.

To control the flow of water from the storage reservoir a discharge or outlet gate should be firmly built into the banks in such manner that seepage water will not find its way along it and thus erode the reservoir wall. It should be located at the lowest point of the reservoir bed, which may be previously graded to slope toward it. Such

an outlet sluice may be satisfactorily constructed of wood by building out wing walls on both the outer and the inner surfaces of the embankments and inclining its bottom ends downward into the ground so as to prevent the seepage of water about the resulting box-like channel or flume. Additional security against the travel of seepage water may be had by running a row of sheet piling tightly connected with the box flume back through the center of the embankment for some distance. In this box flume should be erected a small lifting gate which can be raised to any desired extent so as to permit of the discharge of such volumes as may be required in irrigating the fields.

INDEX.

Page.		Page.
<p>Animsl motive powers, descriptions and figures of 20-25</p> <p>Austin Manufacturing Company, Chicago, Improved Current Motor of..... 41-42</p> <p>Buckley, R. B., cited 21</p> <p>Centrifugal pumps, use of..... 50-51</p> <p>Chesapeake and Delaware Canal, wheel for lifting water on..... 42-43</p> <p>Cost of water for irrigation 16</p> <p>Doon of India, description and figure of... 21-22</p> <p>Frizell, E. E., windmill pumping plant of... 35</p> <p>Gssoline pumping engines, use of..... 45-46</p> <p>Griffiths, J. A., cited..... 28</p> <p>Hot-air pumping engines, use of..... 45-46</p> <p>Huffer pump, description of..... 49</p> <p>Hydraulic rams, use of..... 43-45</p> <p>Hydrographic papers in preparation, subjects of..... 11-12</p> <p>Irrigation, cost of water for..... 16</p> <p style="padding-left: 20px;">use of wells for..... 17</p> <p>Irrigation and water-supply papers, character, subjects and proposed distribution of..... 11-12</p> <p>Isl of Man, large overshot water wheel on..... 39</p> <p>Jumbo wind wheel, use of..... 30</p> <p>Latha of India, description and figure of... 21, 22</p> <p>Lemichel et Cie, siphon elevator of..... 52</p> <p>Menge pump, description of..... 49-50</p> <p>Mogul windmill, use of..... 30</p> <p>Motive powere and pompe, enumeration and classification of..... 17-19</p> <p>Mot of India, description and figure of..... 22-23</p> <p>National Pump Company, rotary pump made by..... 51</p> <p>Newell, F. H., letter of trausmittal and preface by..... 9-13</p> <p style="padding-left: 20px;">cited..... 16</p> <p>Noria, use of..... 36</p> <p>North Star Mining Company, California, Pelton wheel of..... 41</p> <p>Nye pump, description of..... 49</p> <p>Pæcottah of India, description and figure of. 20-21</p> <p>Persian wheel, description and figure of.... 23-24</p> <p style="padding-left: 20px;">description and figure of modern adaptation of..... 23, 24</p> <p>Pelton water wheel, description and figure of..... 41</p>	<p>Prosser Falls, Washington, turbine power and pumping plant at..... 40</p> <p>Pumping engines, hot air and gasoline.... 45-46</p> <p style="padding-left: 20px;">steam..... 46-50</p> <p>Pumps and motive powers, enumeration and classification of..... 17-19</p> <p>Pumps, irrigation in India by..... 17</p> <p style="padding-left: 20px;">capacities of..... 35</p> <p style="padding-left: 20px;">centrifugal..... 50-51</p> <p style="padding-left: 20px;">rotary..... 51</p> <p>Rams (hydraulic), use of..... 43-45</p> <p>Reservoirs for storage of water, form and character of..... 54-56</p> <p>Rotary pumps, use of..... 51</p> <p>Scientific American, cited..... 37</p> <p>Seaman irrigating pump, description of.... 52</p> <p>Shadoof of India, description and figure of. 20-21</p> <p>Siphon water elevators, description and figure of..... 52-53</p> <p>Steam pumping engines, use of..... 46-50</p> <p>Storage reservoirs, form and character of.. 54-56</p> <p>Summit Lake Water Compsny of California, centrifugal pumping plant of.. 51</p> <p>Turbine water wheels, description and figure of..... 39-40</p> <p>Tympanum, description of..... 37</p> <p>Vermilion Canal Compsny of Louisiana, centrifugal pumping plant of..... 50</p> <p>Water for irrigation, cost of..... 16</p> <p>Water elevators (mechanical and siphon), descriptions of..... 51-53</p> <p>Water rental, cost per acre..... 16</p> <p>Water-supply and irrigation papers, character, subjects, and proposed distri bution of..... 11-12</p> <p>Water wheels, descriptions and figures of... 35-43</p> <p>Weisbach and Du Bois, cited..... 30, 38</p> <p>Wells, irrigation from..... 17</p> <p>Windmill pumping plants, cost of irrigation by..... 16</p> <p>Windmills, descriptions and figures of.... 25-35</p> <p style="padding-left: 20px;">capacities of..... 28-29</p> <p>Wind Rustler, use of..... 30</p> <p>Wind velocity and power, table showing... 27</p> <p>Wolff, A. R., cited..... 28</p> <p>Zigzag halance of Asia Minor and Egypt, description and figure of..... 24-25, 26</p>	<p>57</p>

